

Nonlinear H-infinity Feedback Control for Asynchronous Motors of Electric Trains

G. Rigatos¹ · P. Siano² · P. Wira³ · F. Profumo⁴

Received: 1 December 2014 / Revised: 30 March 2015 / Accepted: 13 July 2015 / Published online: 11 August 2015
© Springer Science+Business Media Singapore 2015

Abstract A new method for feedback control of asynchronous electrical machines is introduced, with application example the problem of the traction system of electric trains. The control method consists of a repetitive solution of an H-infinity control problem for the asynchronous motor, that makes use of a locally linearized model of the motor and takes place at each iteration of the control algorithm. The asynchronous motor's model is locally linearized round its current operating point through the computation of the associated Jacobian matrices. Using the linearized model of the electrical machine an H-infinity feedback control law is computed. The known robustness features of H-infinity control enable to compensate for the errors of the approximative linearization, as well as to eliminate the effects of external perturbations. The efficiency of the proposed control scheme is shown analytically and is confirmed through simulation experiments.

Keywords Nonlinear H-infinity feedback control · Robust control · Asynchronous electric motors · Electrical trains

Introduction

Efficient control of the traction system of electric trains is important for improving their performance indexes (e.g. acceleration, maximum speed, motor's torque) as well as their safety features [1–4]. To this end, in the recent years several research results have been produced on control of induction motors, which are frequently used for the traction of electric trains (and particularly of high-speed trains) [5–8]. Induction motors (IM) have been the most widely used machines in fixed-speed applications for reasons of cost, size, weight, reliability, ruggedness, simplicity, efficiency, and ease of manufacture. The induction motor model is a highly nonlinear one and is characterized by the difficulty in measuring certain of its state vector elements (e.g. magnetic flux) [9]. With the field-oriented method, the dynamic behavior of the induction motor is rather similar to that of a separately excited DC motor [10, 11]. A decoupled relationship is obtained by means of a proper selection of state coordinates and thus, the rotor speed is asymptotically decoupled from the rotor flux, while the speed can be controlled only by varying the stator's currents [12, 13]. On the other hand certain approaches try to develop control for induction motors based on feedback linearization of its dynamics [14–18]. The control performance of the induction motor is influenced by the uncertainties of motor's dynamic model, such as mechanical parameter uncertainty, external load disturbance, and unmodelled dynamics in practical applications. Thus other approaches try to provide induction motor control with improved robustness features [19–21].

✉ G. Rigatos
grigat@ieee.org; mechatronicsandai@gmail.com

P. Siano
psiano@unisa.it

P. Wira
pwira@uha.fr

F. Profumo
francesco.profumo@polito.it

¹ Unit of Industrial Automation, Industrial Systems Institute, 26504 Rion Patras, Greece
² Department of Industrial Engineering, University of Salerno, 84084 Fisciano, Italy
³ Laboratoire MIPS, Université de Haute Alsace, 68093 Mulhouse Cedex, France
⁴ DENERG - Dipartimento Energia, Politecnico di Torino, 10129 Turin, Italy

In this research article a new control method for induction motors is developed, based on nonlinear H-infinity control theory. The application of an approximate linearization scheme for the dynamic model of the induction motor is proposed, based on Taylor series expansion round the motor's present operating point. To perform this linearization the computation of Jacobian matrices is needed while the induced linearization error terms are treated as disturbances. For the linearized equivalent of the asynchronous motor's model an H_∞ feedback control scheme is developed. The formulation of the H_∞ control problem is based on the minimization of a quadratic cost function that comprises both the disturbance and the control input effects. The disturbance tries to maximize the cost function while the control signal tries to minimize it, within a mini-max differential game. The efficiency of the proposed nonlinear H_∞ control scheme has been tested through simulation experiments, which have shown a satisfactory performance.

Comparing to nonlinear feedback control approaches which are based on exact feedback linearization of the induction motor (as the ones based on differential flatness theory and analyzed in Ref. [22–24]) the proposed H_∞ control scheme is assessed as follows: (i) it uses an approximate linearization approach of the system's dynamic model which does not follow the elaborated transformations (diffeomorphisms) of the exact linearization methods, (ii) it introduces additional disturbance error which is due to the approximative linearization of the system dynamics coming from the application of Taylor series expansion [25–27], (iii) it requires the computation of Jacobian matrices, which in the case of the sixth-order asynchronous motor model can be also a cumbersome procedure, (iv) unlike exact feedback linearization, the H_∞ control term has to compensate not only for modelling uncertainties and external disturbances but needs also to annihilate the effects of the cumulative linearization error, (v) the H_∞ control approach follows an optimal control method for the computation of the control signal, however unlike exact feedback linearization control it requires the solution of Riccati equations which for the sixth-order induction motor's model can be again a cumbersome procedure.

The structure of the paper is as follows: in “Mathematical Model of the Induction Motor” section, the dynamic model of the induction motor is analyzed. In “Field Oriented Control” section, an overview of field-oriented control of induction motors and the associated dynamic model in the dq reference frame are given. In “Linearization of the Induction Motor's Dynamic Model” section, linearization of the induction motor's model is performed round local operating points and through the computation of Jacobian matrices. In “The Nonlinear H-infinity Control” section, the nonlinear H_∞ feedback control law is formulated. In “Lyapunov

Stability Analysis” section, Lyapunov stability analysis is provided for the control loop of the asynchronous motor. In “Robust state estimation with the use of the H_∞ Kalman Filter” section the problem of robust estimation for the induction motor is treated with the use of the H-infinity Kalman Filter. In “Simulation Tests” section, the performance of the proposed control scheme is tested through simulation experiments. Finally, in “Conclusions” section, concluding remarks are stated.

Mathematical Model of the Induction Motor

To derive the dynamic model of an induction motor the three-phase variables are first transformed to two-phase ones [14–17]. This two-phase system can be described in the stator-coordinates frame $\alpha - b$, and the associated voltages are denoted as $v_{s\alpha}$ and v_{sb} , while the currents of the stator are $i_{s\alpha}$ and i_{sb} , respectively (see Fig. 1). Then, the rotation angle of the rotor with respect to the stator is denoted by δ . Next, the rotating reference frame $d - q$ on rotor, is defined. The currents of the rotor are decomposed into $d - q$ coordinates, thus resulting into i_{rd} and i_{rq} . Since the frame $d - q$ of the rotor aligns with the frame $\alpha - b$ of the stator after rotation by an angle δ it holds that

$$\begin{pmatrix} i_{r\alpha} \\ i_{rb} \end{pmatrix} = \begin{pmatrix} \cos(\delta) & -\sin(\delta) \\ \sin(\delta) & \cos(\delta) \end{pmatrix} \begin{pmatrix} i_{rd} \\ i_{rq} \end{pmatrix} \quad (1)$$

The voltage developed along frame α of the stator is given by

$$R_s i_{s\alpha} + \frac{d\psi_{s\alpha}}{dt} = v_{s\alpha} \quad (2)$$

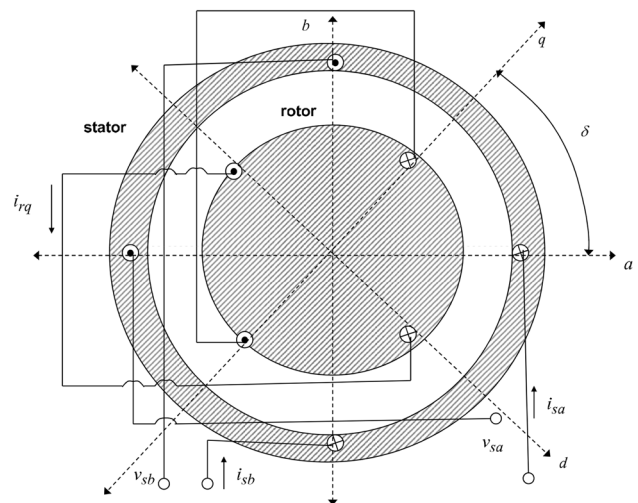

Fig. 1 AC motor circuit, with the $a - b$ stator reference frame and the $d' - q'$ rotor reference frame

where the magnetic flux $\psi_{s\alpha}$ is the result of the magnetic flux that is generated by current $i_{s\alpha}$ of the stator (self-inductance) and of the magnetic flux which is generated by current $i_{r\alpha}$ of the rotor (mutual inductance), i.e.

$$\psi_{s\alpha} = L_s i_{s\alpha} + M i_{r\alpha} \tag{3}$$

The voltage developed along frame b of the stator is

$$R_s i_{sb} + \frac{d}{dt} \psi_{sb} = u_{sb} \tag{4}$$

where the magnetic flux ψ_{sb} is the result of the magnetic flux that is generated by current i_{sb} of the stator (self-inductance) and of the magnetic flux which is generated by current i_{rb} of the rotor (mutual inductance), i.e.

$$\psi_{sb} = L_s i_{sb} + M i_{rb} \tag{5}$$

Similarly the voltage along frames d and q of the rotor is calculated as follows

$$R_r i_{rd} + \frac{d}{dt} \psi_{rd} = 0 \tag{6}$$

$$R_r i_{rq} + \frac{d}{dt} \psi_{rq} = 0 \tag{7}$$

After intermediate computations the equations of the induction motor are found to be:

$$R_s i_{s\alpha} + \frac{M}{L_r} \frac{d}{dt} \psi_{r\alpha} + \left(L_s - \frac{M^2}{L_r} \right) \frac{d}{dt} i_{s\alpha} = v_{s\alpha} \tag{8}$$

$$R_s i_{sb} + \frac{M}{L_r} \frac{d}{dt} \psi_{rb} + \left(L_s - \frac{M^2}{L_r} \right) \frac{d}{dt} i_{sb} = v_{sb} \tag{9}$$

$$\frac{R_r}{L_r} \psi_{r\alpha} - \frac{R_r M}{L_r} i_{s\alpha} + \frac{d}{dt} \psi_{r\alpha} + n_p \omega \psi_{rb} = 0 \tag{10}$$

$$\frac{R_r}{L_r} \psi_{rb} - \frac{R_r M}{L_r} i_{sb} + \frac{d}{dt} \psi_{rb} + n_p \omega \psi_{r\alpha} = 0 \tag{11}$$

The torque that is applied to the rotor is developed according to the principle of energy preservation and is given by

$$T = \frac{n_p M}{L_r} (\psi_{r\alpha} i_{sb} - \psi_{rb} i_{s\alpha}) \tag{12}$$

If the motor has to move a load of torque T_L it holds

$$J \dot{\omega} = T - T_L \Rightarrow \dot{\omega} = \frac{T}{J} - \frac{T_L}{J} \Rightarrow \dot{\omega} = \frac{n_p M}{J L_r} (\psi_{r\alpha} i_{sb} - \psi_{rb} i_{s\alpha}) - \frac{T_L}{J} \tag{13}$$

Denoting $\sigma = 1 - \frac{M^2}{L_s L_r}$, the equations of the induction motor are finally written as:

$$\dot{\theta} = \omega \tag{14}$$

$$\frac{d\omega}{dt} = \frac{n_p M}{J L_r} (\psi_{r\alpha} i_{sb} - \psi_{rb} i_{s\alpha}) - \frac{T_L}{J} \tag{15}$$

$$\frac{d\psi_{r\alpha}}{dt} = -\frac{R_r}{L_r} \psi_{r\alpha} - n_p \omega \psi_{rb} + \frac{R_r}{L_r} M i_{s\alpha} \tag{16}$$

$$\frac{d\psi_{rb}}{dt} = -\frac{R_r}{L_r} \psi_{rb} + n_p \omega \psi_{r\alpha} + \frac{R_r}{L_r} M i_{sb} \tag{17}$$

$$\frac{d}{dt} i_{s\alpha} = \frac{M R_r}{\sigma L_s L_r^2} \psi_{r\alpha} + \frac{n_p M}{\sigma L_s L_r} \omega \psi_{rb} - \left(\frac{M^2 R_r + L_r^2 R_s}{\sigma L_s L_r^2} \right) i_{s\alpha} + \frac{1}{\sigma L_s} v_{s\alpha} \tag{18}$$

$$\frac{d}{dt} i_{sb} = -\frac{n_p M}{\sigma L_s L_r} \omega \psi_{r\alpha} + \frac{M R_r}{\sigma L_s L_r^2} \psi_{rb} - \left(\frac{M^2 R_r + L_r^2 R_s}{\sigma L_s L_r^2} \right) i_{sb} + \frac{1}{\sigma L_s} v_{sb} \tag{19}$$

Therefore one can define the state vector $x = [\theta, \omega, \psi_{r\alpha}, \psi_{rb}, i_{s\alpha}, i_{sb}]^T$. Uncertainty can be associated with the value of the load torque T_L , or the value of the components of the electric circuits of the stator and the rotor. The following parameters are also defined: $\alpha_1 = \frac{R_r}{L_r}$, $\beta_1 = \frac{M}{\sigma L_s L_r}$, $\gamma_1 = \left(\frac{M^2 R_r}{\sigma L_s L_r^2} + \frac{R_s}{\sigma L_s} \right)$, $\mu_1 = \frac{n_p M}{J L_r}$. Therefore, the dynamic model of the induction motor can be written as:

$$\dot{x} = f(x) + g_\alpha u_{s\alpha} + g_b u_{sb} \tag{20}$$

In state equations form, the dynamic model of the motor can be written as

$$f(x) = \begin{pmatrix} x_2 \\ \mu_1(x_3 x_6 - x_4 x_5) - \frac{T_L}{J} \\ \alpha_1 x_3 - n_p x_2 x_4 + \alpha_1 M x_5 \\ n_p x_2 x_3 - \alpha_1 x_4 + \alpha_1 M x_6 \\ \alpha_1 \beta_1 x_3 + n_p \beta_1 x_2 x_4 - \gamma_1 x_5 \\ -n_p \beta_1 x_2 x_3 + \alpha_1 \beta_1 x_4 - \gamma_1 x_6 \end{pmatrix} \tag{21}$$

$$g_\alpha = \left[0, 0, 0, 0, \frac{1}{\sigma L_s}, 0 \right]^T$$

$$g_b = \left[0, 0, 0, 0, 0, \frac{1}{\sigma L_s} \right]^T \tag{22}$$

Field Oriented Control

The classical method for induction motors control was introduced by Blaschke (1971) and is based on a transformation of the stator's currents ($i_{s\alpha}$) and (i_{sb}) and of the magnetic fluxes of the rotor ($\psi_{r\alpha}$ and ψ_{rb}) to the reference frame $d - q$ which rotates together with the rotor [14–17]. Thus the controller's design uses the currents i_{sd} and i_{sq} and the fluxes ψ_{rd} and

ψ_{r_q} . The angle of the vectors that describe the magnetic fluxes ψ_{r_α} and ψ_{r_b} is first defined, i.e.

$$\rho = \tan^{-1} \left(\frac{\psi_{r_b}}{\psi_{r_a}} \right) \tag{23}$$

The angle between the inertial reference frame of the stator and the rotating reference frame of the rotor is taken to be equal to ρ . The transition from (i_{s_α}, i_{s_b}) to (i_{s_d}, i_{s_q}) is given by

$$\begin{pmatrix} i_{s_d} \\ i_{s_q} \end{pmatrix} = \begin{pmatrix} \cos(\rho) & \sin(\rho) \\ -\sin(\rho) & \cos(\rho) \end{pmatrix} \begin{pmatrix} i_{s_\alpha} \\ i_{s_b} \end{pmatrix} \tag{24}$$

The transition from $(\psi_{r_\alpha}, \psi_{r_b})$ to (ψ_{r_d}, ψ_{r_q}) is given by

$$\begin{pmatrix} \psi_{r_d} \\ \psi_{r_q} \end{pmatrix} = \begin{pmatrix} \cos(\rho) & \sin(\rho) \\ -\sin(\rho) & \cos(\rho) \end{pmatrix} \begin{pmatrix} \psi_{r_\alpha} \\ \psi_{r_b} \end{pmatrix} \tag{25}$$

Moreover, it holds that $\cos(\rho) = \frac{\psi_{r_\alpha}}{\|\psi\|}$, $\sin(\rho) = \frac{\psi_{r_b}}{\|\psi\|}$, and $\|\psi\| = \sqrt{\psi_{r_\alpha}^2 + \psi_{r_b}^2}$. Using the above transformation ones obtains

$$\begin{aligned} i_{s_d} &= \frac{\psi_{r_\alpha} i_{s_\alpha} + \psi_{r_b} i_{s_b}}{\|\psi\|} & \psi_{r_d} &= \|\psi\| \\ i_{s_q} &= \frac{\psi_{r_\alpha} i_{s_b} - \psi_{r_b} i_{s_\alpha}}{\|\psi\|} & \psi_{r_q} &= 0 \end{aligned} \tag{26}$$

Therefore, in the rotating frame $d - q$ of the motor there will be only one non-zero component of the magnetic flux ψ_{r_d} , while the component of the flux along the d axis equals 0. The new inputs of the system are considered to be v_{s_d}, v_{s_q} , which are connected to v_{s_a}, v_{s_b} according to the relation

$$\begin{pmatrix} v_{s_\alpha} \\ v_{s_b} \end{pmatrix} = \|\psi\| \cdot \begin{pmatrix} \psi_{r_\alpha} & \psi_{r_b} \\ \psi_{r_b} & \psi_{r_\alpha} \end{pmatrix}^{-1} \begin{pmatrix} v_{s_d} \\ v_{s_q} \end{pmatrix} \tag{27}$$

In the new coordinates the induction motor model is written as:

$$\frac{d}{dt} \theta = \omega \tag{28}$$

$$\frac{d}{dt} \omega = \mu \psi_{r_d} i_{s_q} - \frac{T_L}{J} \tag{29}$$

$$\frac{d}{dt} \psi_{r_d} = -\alpha \psi_{r_d} + \alpha M i_{s_d} \tag{30}$$

$$\begin{aligned} \frac{d}{dt} i_{s_d} &= -\gamma i_{s_d} + \alpha \beta \psi_{r_d} + n_p \omega i_{s_q} \\ &+ \frac{\alpha M i_{s_q}^2}{\psi_{r_d}} + \frac{1}{\sigma L_s} v_{s_d} \end{aligned} \tag{31}$$

$$\begin{aligned} \frac{d}{dt} i_{s_q} &= -\gamma i_{s_q} - \beta n_p \omega \psi_{r_d} - n_p \omega i_{s_d} \\ &- \frac{\alpha M i_{s_q} i_{s_d}}{\psi_{r_d}} + \frac{1}{\sigma L_s} v_{s_q} \end{aligned} \tag{32}$$

$$\frac{d}{dt} \rho = n_p \omega + \frac{\alpha M i_{s_q}}{\psi_{r_d}} \tag{33}$$

Defining the state vector of the motor dynamics in the dq reference frame as $x = [\theta, \omega, \psi_{r_d}, i_{s_d}, i_{s_q}, \rho]$ the associated state-space model becomes $\dot{x} = f(x) + g_d v_{s_d} + g_q v_{s_q}$, where

$$f(x) = \begin{pmatrix} x_2 \\ \mu x_3 x_5 - \frac{T_L}{J} \\ -\alpha x_3 + \alpha M x_4 \\ -\gamma x_4 + \alpha \beta x_3 + n_p x_2 x_5 + \frac{\alpha M x_5^2}{x_3} \\ -\gamma x_5 - \beta n_p x_2 x_3 - n_p x_2 x_4 - \frac{\alpha M x_4 x_5}{x_3} \\ n_p x_2 + \frac{\alpha M x_5}{x_3} \end{pmatrix} \tag{34}$$

$$g_d = \left[0, 0, 0, \frac{1}{\sigma L_s}, 0, 0 \right]^T$$

$$g_q = \left[0, 0, 0, 0, \frac{1}{\sigma L_s}, 0 \right]^T \tag{35}$$

Next, the following nonlinear feedback control law is defined

$$\begin{pmatrix} v_{s_d} \\ v_{s_q} \end{pmatrix} = \sigma L_s \begin{pmatrix} -n_p \omega i_{s_q} - \frac{\alpha M i_{s_q}^2}{\psi_{r_d}} - \alpha \beta \psi_{r_d} + v_d \\ n_p \omega i_{s_d} + \beta n_p \omega \psi_{r_d} + \frac{\alpha M i_{s_q} i_{s_d}}{\psi_{r_d}} + v_q \end{pmatrix} \tag{36}$$

The terms in Eq. (36) have been selected so as to linearize Eqs. (30) and (32) and to produce first-order linear ODE. The control signal in the inertial coordinates system $a - b$ will be

$$\begin{pmatrix} v_{s_\alpha} \\ v_{s_b} \end{pmatrix} = \|\psi\| \sigma L_s \begin{pmatrix} \psi_{s_\alpha} & \psi_{s_b} \\ -\psi_{s_b} & \psi_{s_\alpha} \end{pmatrix}^{-1} \begin{pmatrix} -n_p \omega i_{s_q} - \frac{\alpha M i_{s_q}^2}{\psi_{r_d}} - \alpha \beta \psi_{r_d} + v_d \\ n_p \omega i_{s_d} + \beta n_p \omega \psi_{r_d} + \frac{\alpha M i_{s_q} i_{s_d}}{\psi_{r_d}} + v_q \end{pmatrix} \tag{37}$$

Substituting Eq. (36) into Eqs. (30) and (32) one obtains [16]:

$$\dot{\theta} = \omega \tag{38}$$

$$\frac{d}{dt} \omega = \mu \psi_{r_d} i_{s_q} - \frac{T_L}{J} \tag{39}$$

$$\frac{d}{dt} i_{s_q} = -\gamma i_{s_q} + v_q \tag{40}$$

$$\frac{d}{dt} \psi_{r_d} = -\alpha \psi_{r_d} + \alpha M i_{s_d} \tag{41}$$

$$\frac{d}{dt} i_{s_d} = -\gamma i_{s_d} + v_d \tag{42}$$

$$\frac{d}{dt} \rho = n_p \omega + \alpha M \frac{i_{s_q}}{\psi_{r_d}} \tag{43}$$

The system of Eqs. (39) to (43) consists of two linear subsystems, where the first one has as output the magnetic flux ψ_{r_d} and the second has as output the rotation speed ω , i.e.

$$\frac{d}{dt} \psi_{rd} = -\alpha \psi_{rd} + \alpha M i_{sd} \tag{44}$$

$$\frac{d}{dt} i_{sd} = -\gamma i_{sd} + v_d \tag{45}$$

$$\frac{d}{dt} \omega = \mu \psi_{rd} i_{sq} - \frac{T_L}{J} \tag{46}$$

$$\frac{d}{dt} i_{sq} = -\gamma i_{sq} + v_q \tag{47}$$

If $\psi_{rd} \rightarrow \psi_{rd}^{ref}$, i.e. the transient phenomena for ψ_{rd} have been eliminated and therefore ψ_{rd} has converged to a steady state value, then the two subsystems described by Eqs. (44)–(45) and (46)–(47) are decoupled.

The subsystem that is described by Eqs. (44) and (45) is linear with control input v_{sd} , and can be controlled using methods of linear control, such as optimal control, or PID control. For instance the following PI controller has been proposed for the control of the magnetic flux

$$v_d(t) = -k_{d1}(\psi_{rd} - \psi_{rd}^{ref}) - k_{d2} \int_0^t (\psi_{rd}(\tau) - \psi_{rd}^{ref}(\tau)) d\tau \tag{48}$$

If Eq. (48) is applied to the subsystem that is described by Eqs. (44) and (45), then one can succeed $\psi_{rd}(t) \rightarrow \psi_{rd}^{ref}(t)$. If $\psi_{rd}(t)$ is not sufficiently measurable using Hall sensors then it can be reconstructed using some kind of observer or Kalman Filtering. Now, the subsystem that consists of Eqs. (46) and (47) is examined. The term $T = \mu \psi_{rd}^{ref} i_{sq}$ denotes the torque developed by the motor. The above mentioned subsystem is a model equivalent to that of a DC motor and thus after succeeding $\psi_{rd} \rightarrow \psi_{rd}^{ref}$, one can also control the motor’s speed ω , using control algorithms already applied to the control of DC motors. A first approach to the control of the speed ω is to use nested PI loops, i.e.

$$v_q = -K_{q1}(T - T_{ref}) - K_{q2} \int_0^t (T(t) - T_{ref}(t)) d\tau \tag{49}$$

$$T_{ref} = -K_{q3}(\omega - \omega_{ref}) - K_{q4} \int_0^t (\omega(t) - \omega_{ref}(t)) d\tau$$

From the above it can be seen that field oriented (vector control) for induction motors requires the tuning of the several PID-type controllers and this limits the method’s reliability only round local operating points. Consequently, the stability and robustness properties of the field-oriented control for asynchronous motors are doubtful. More efficient control approaches, of proven stability, have to be searched for. This problem will be solved in the following sections.

Linearization of the Induction Motor’s Dynamic Model

As shown in “Field Oriented Control” section, the nonlinear state space equation of the induction motor, expressed in the dq reference frame, is given by

$$\dot{x} = f(x) + g_d v_{sd} + g_q v_{sq} \tag{50}$$

where the state vector has been defined as $x = [\theta, \omega, \psi_{rd}, i_{sd}, i_{sq}, \rho]$ while functions $f(x)$, $g_a(x)$ and $g_b(x)$ have been defined as

$$f(x) = \begin{pmatrix} x_2 \\ \mu x_3 x_5 - \frac{T_L}{J} \\ -\alpha x_3 + \alpha M x_4 \\ -\gamma x_4 + \alpha \beta x_3 + n_p x_2 x_5 + \frac{\alpha M x_5^2}{x_3} \\ -\gamma x_5 - \beta n_p x_2 x_3 - n_p x_2 x_4 - \frac{\alpha M x_4 x_5}{x_3} \\ n_p x_2 + \frac{\alpha M x_5}{x_3} \end{pmatrix} \tag{51}$$

$$g_d = \left[0, 0, 0, \frac{1}{\sigma L_s}, 0, 0 \right]^T$$

$$g_q = \left[0, 0, 0, 0, \frac{1}{\sigma L_s}, 0 \right]^T \tag{52}$$

Then, the Jacobian matrix of the vector field $f(x)$ is:

$$A = J_\phi = \begin{pmatrix} 0 & 1 & 0 & 0 & 0 & 0 \\ 0 & 0 & \mu x_5 & 0 & \mu x_3 & 0 \\ 0 & 0 & -\alpha & \alpha M & 0 & 0 \\ 0 & n_p x_5 & \alpha \beta - \frac{\alpha M x_5^2}{x_3^2} & -\gamma & n_p x_2 + \frac{2\alpha M x_5}{x_3} & 0 \\ 0 & -\beta n_p x_3 - n_p x_4 & -\beta n_p x_2 + \frac{\alpha M x_4 x_5}{x_3^2} & -n_p x_2 - \frac{\alpha M x_5}{x_3} & -\gamma - \frac{\alpha M x_4}{x_3} & 0 \\ 0 & n_p & -\frac{\alpha M x_5}{x_3^2} & 0 & \frac{\alpha M}{x_3} & 0 \end{pmatrix} \tag{53}$$

Moreover, linearization of the motor’s dynamics with respect to the control input variables u_1, u_2 gives the Jacobian matrix

$$B = [J_{g_a} J_{g_b}] = \begin{pmatrix} 0 & 0 \\ 0 & 0 \\ 0 & 0 \\ \frac{1}{\sigma L_s} & 0 \\ 0 & \frac{1}{\sigma L_s} \\ 0 & 0 \end{pmatrix} \tag{54}$$

Thus, after linearization round its current operating point, the induction motor’s dynamic model is written as

$$\dot{x} = Ax + Bu + d_1 \tag{55}$$

Parameter d_1 stands for the linearization error in the induction motor’s dynamic model appearing in Eq. (55). The reference setpoints for the asynchronous motor are denoted by $\mathbf{x}_d = [x_1^d, \dots, x_6^d]$. Tracking of this trajectory is succeeded after applying the control input u^* . At every time instant the control input u^* is assumed to differ from the control input u appearing in Eq. (55) by an amount equal to Δu , that is $u^* = u + \Delta u$

$$\dot{x}_d = Ax_d + Bu^* + d_2 \tag{56}$$

The dynamics of the controlled system described in Eq. (55) can be also written as

$$\dot{x} = Ax + Bu + Bu^* - Bu^* + d_1 \tag{57}$$

and by denoting $d_3 = -Bu^* + d_1$ as an aggregate disturbance term one obtains

$$\dot{x} = Ax + Bu + Bu^* + d_3 \tag{58}$$

By subtracting Eq. (56) from Eq. (58) one has

$$\dot{x} - \dot{x}_d = A(x - x_d) + Bu + d_3 - d_2 \tag{59}$$

By denoting the tracking error as $e = x - x_d$ and the aggregate disturbance term as $\tilde{d} = d_3 - d_2$, the tracking error dynamics becomes

$$\dot{e} = Ae + Bu + \tilde{d} \tag{60}$$

The above linearized form of the induction motor’s model can be efficiently controlled after applying an H-infinity feedback control scheme.

The Nonlinear H-infinity Control

Mini-max Control and Disturbance Rejection

The initial nonlinear model of the induction motor is in the form

$$\dot{x} = f(x, u) \quad x \in R^n, \quad u \in R^m \tag{61}$$

Linearization of the system (asynchronous motor) is performed at each iteration of the control algorithm round its present operating point $(x^*, u^*) = (x(t), u(t - T_s))$. The linearized equivalent of the system is described by

$$\dot{x} = Ax + Bu + L\tilde{d} \quad x \in R^n, \quad u \in R^m, \quad \tilde{d} \in R^q \tag{62}$$

where matrices A and B are obtained from the computation of the Jacobians

$$A = \begin{pmatrix} \frac{\partial f_1}{\partial x_1} & \frac{\partial f_1}{\partial x_2} & \dots & \frac{\partial f_1}{\partial x_n} \\ \frac{\partial f_2}{\partial x_1} & \frac{\partial f_2}{\partial x_2} & \dots & \frac{\partial f_2}{\partial x_n} \\ \dots & \dots & \dots & \dots \\ \frac{\partial f_n}{\partial x_1} & \frac{\partial f_n}{\partial x_2} & \dots & \frac{\partial f_n}{\partial x_n} \end{pmatrix} \Big|_{(x^*, u^*)} \tag{63}$$

$$B = \begin{pmatrix} \frac{\partial f_1}{\partial u_1} & \frac{\partial f_1}{\partial u_2} & \dots & \frac{\partial f_1}{\partial u_m} \\ \frac{\partial f_2}{\partial u_1} & \frac{\partial f_2}{\partial u_2} & \dots & \frac{\partial f_2}{\partial u_m} \\ \dots & \dots & \dots & \dots \\ \frac{\partial f_n}{\partial u_1} & \frac{\partial f_n}{\partial u_2} & \dots & \frac{\partial f_n}{\partial u_m} \end{pmatrix} \Big|_{(x^*, u^*)} \tag{64}$$

and vector \tilde{d} denotes disturbance terms due to linearization errors. The problem of disturbance rejection for the linearized model that is described by

$$\begin{aligned} \dot{x} &= Ax + Bu + L\tilde{d} \\ y &= Cx \end{aligned} \tag{65}$$

where $x \in R^n, u \in R^m, \tilde{d} \in R^q$ and $y \in R^p$, cannot be handled efficiently if the classical LQR control scheme is applied. This is because of the existence of the perturbation term \tilde{d} . The disturbance term \tilde{d} apart from modeling (parametric) uncertainty and external perturbation terms can also represent noise terms of any distribution.

In the H_∞ control approach, a feedback control scheme is designed for trajectory tracking by the system’s state vector and simultaneous disturbance rejection, considering that the disturbance affects the system in the worst possible manner. The disturbances’ effect are incorporated in the following quadratic cost function:

$$J(t) = \frac{1}{2} \int_0^T [y^T(t)y(t) + ru^T(t)u(t) - \rho^2 \tilde{d}^T(t)\tilde{d}(t)]dt, \quad r, \rho > 0 \quad (66)$$

The significance of the negative sign in the cost function’s term that is associated with the perturbation variable $\tilde{d}(t)$ is that the disturbance tries to maximize the cost function $J(t)$ while the control signal $u(t)$ tries to minimize it. The physical meaning of the relation given above is that the control signal and the disturbances compete to each other within a mini-max differential game. This problem of mini-max optimization can be written as

$$\min_u \max_{\tilde{d}} J(u, \tilde{d}) \quad (67)$$

The objective of the optimization procedure is to compute a control signal $u(t)$ which can compensate for the worst possible disturbance, that is externally imposed to the system. However, the solution to the mini-max optimization problem is directly related to the value of the parameter ρ . This means that there is an upper bound in the disturbances magnitude that can be annihilated by the control signal.

H-infinity Feedback Control

For the linearized system given by Eq. (65) the cost function of Eq. (66) is defined, where the coefficient r determines the penalization of the control input and the weight coefficient

ρ determines the reward of the disturbances’ effects. It is assumed that:

It is assumed that (i) The energy that is transferred from the disturbances signal $\tilde{d}(t)$ is bounded, that is $\int_0^\infty \tilde{d}^T(t)\tilde{d}(t)dt < \infty$, (ii) the matrices $[A, B]$ and $[A, L]$ are stabilizable, (iii) the matrix $[A, C]$ is detectable. Then, the optimal feedback control law is given by

$$u(t) = -Kx(t) \quad (68)$$

with

$$K = \frac{1}{r} B^T P \quad (69)$$

where P is a positive semi-definite symmetric matrix which is obtained from the solution of the Riccati equation

$$A^T P + PA + Q - P \left(\frac{1}{r} BB^T - \frac{1}{2\rho^2} LL^T \right) P = 0 \quad (70)$$

where Q is also a positive definite symmetric matrix. The worst case disturbance is given by

$$\tilde{d}(t) = \frac{1}{\rho^2} L^T P x(t) \quad (71)$$

The diagram of the considered control loop is depicted in Fig. 2.

Fig. 2 Diagram of the control scheme for the train’s induction motor

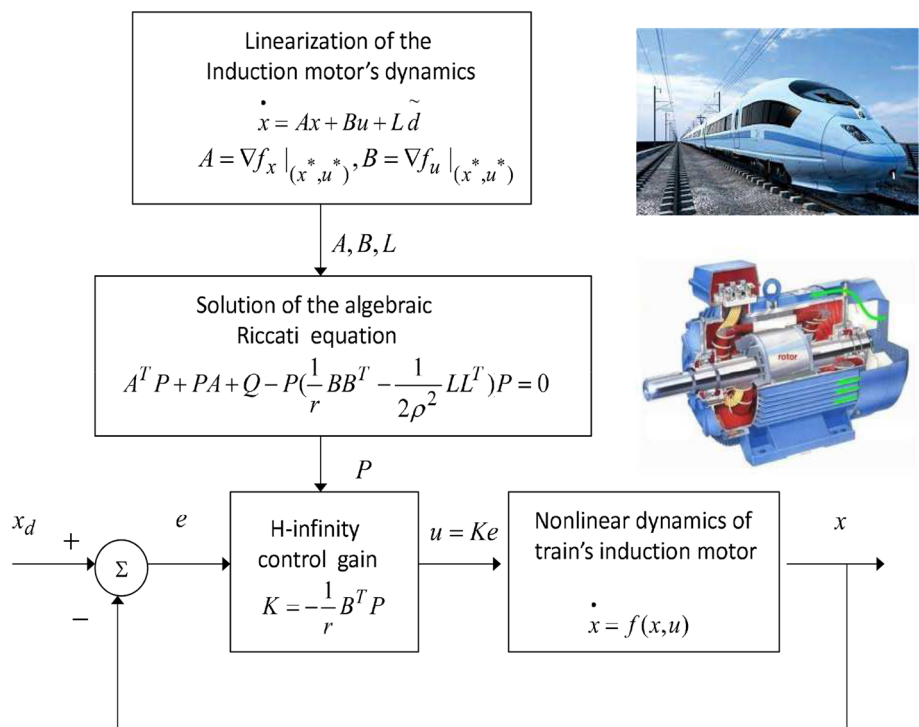

The Role of Riccati Equation Coefficients in H_∞ Control Robustness

The parameter ρ in Eq. (66), is an indication of the closed-loop system robustness. If the values of $\rho > 0$ are excessively decreased with respect to r , then the solution of the Riccati equation is no longer a positive definite matrix. Consequently there is a lower bound ρ_{min} of ρ for which the H_∞ control problem has a solution. The acceptable values of ρ lie in the interval $[\rho_{min}, \infty)$. If ρ_{min} is found and used in the design of the H_∞ controller, then the closed-loop system will have increased robustness. Unlike this, if a value $\rho > \rho_{min}$ is used, then an admissible stabilizing H_∞ controller will be derived but it will be a suboptimal one. The Hamiltonian matrix

$$H = \begin{pmatrix} A & -\left(\frac{1}{r}BB^T - \frac{1}{\rho^2}LL^T\right) \\ -Q & -A^T \end{pmatrix} \quad (72)$$

provides a criterion for the existence of a solution of the Riccati equation Eq. (70). A necessary condition for the solution of the algebraic Riccati equation to be a positive semi-definite symmetric matrix is that H has no imaginary eigenvalues [22].

Lyapunov Stability Analysis

Through Lyapunov stability analysis it will be shown that the proposed nonlinear control scheme assures H_∞ tracking performance for the induction motor, and that in case of bounded disturbance terms asymptotic convergence to the reference setpoints is succeeded.

The tracking error dynamics for the asynchronous motor is written in the form

$$\dot{e} = Ae + Bu + L\tilde{d} \quad (73)$$

where in the induction machine's case $L = I \in R^2$ with I being the identity matrix. Variable \tilde{d} denotes model uncertainties and external disturbances of the motor's model. The following Lyapunov equation is considered

$$V = \frac{1}{2}e^T P e \quad (74)$$

where $e = x - x_d$ is the tracking error. By differentiating with respect to time one obtains

$$\begin{aligned} \dot{V} &= \frac{1}{2}\dot{e}^T P e + \frac{1}{2}e^T P \dot{e} \Rightarrow \\ \dot{V} &= \frac{1}{2}[Ae + Bu + L\tilde{d}]^T P + \frac{1}{2}e^T P [Ae + Bu + L\tilde{d}] \Rightarrow \end{aligned} \quad (75)$$

$$\begin{aligned} \dot{V} &= \frac{1}{2}[e^T A^T + u^T B^T + \tilde{d}^T L^T] P e \\ &+ \frac{1}{2}e^T P [Ae + Bu + L\tilde{d}] \Rightarrow \end{aligned} \quad (76)$$

$$\begin{aligned} \dot{V} &= \frac{1}{2}e^T A^T P e + \frac{1}{2}u^T B^T P e + \frac{1}{2}\tilde{d}^T L^T P e \\ &+ \frac{1}{2}e^T P A e + \frac{1}{2}e^T P B u + \frac{1}{2}e^T P L \tilde{d} \end{aligned} \quad (77)$$

The previous equation is rewritten as

$$\begin{aligned} \dot{V} &= \frac{1}{2}e^T (A^T P + P A) e + \left(\frac{1}{2}u^T B^T P e + \frac{1}{2}e^T P B u \right) \\ &+ \left(\frac{1}{2}\tilde{d}^T L^T P e + \frac{1}{2}e^T P L \tilde{d} \right) \end{aligned} \quad (78)$$

Assumption For given positive definite matrix Q and coefficients r and ρ there exists a positive definite matrix P , which is the solution of the following matrix equation

$$A^T P + P A = -Q + P \left(\frac{1}{r}BB^T - \frac{1}{\rho^2}LL^T \right) P \quad (79)$$

Moreover, the following feedback control law is applied to the system

$$u = -\frac{1}{r}B^T P e \quad (80)$$

By substituting Eqs. (79) and (80) one obtains

$$\begin{aligned} \dot{V} &= \frac{1}{2}e^T \left[-Q + P \left(\frac{1}{r}BB^T - \frac{1}{2\rho^2}LL^T \right) P \right] e \\ &+ e^T P B \left(-\frac{1}{r}B^T P e \right) + e^T P L \tilde{d} \Rightarrow \end{aligned} \quad (81)$$

$$\begin{aligned} \dot{V} &= -\frac{1}{2}e^T Q e + \left(\frac{1}{r}PBB^T P e - \frac{1}{2\rho^2}e^T PLL^T \right) P e \\ &- \frac{1}{r}e^T PBB^T P e + e^T P L \tilde{d} \end{aligned} \quad (82)$$

which after intermediate operations gives

$$\dot{V} = -\frac{1}{2}e^T Q e - \frac{1}{2\rho^2}e^T PLL^T P e + e^T P L \tilde{d} \quad (83)$$

or, equivalently

$$\begin{aligned} \dot{V} &= -\frac{1}{2}e^T Q e - \frac{1}{2\rho^2}e^T PLL^T P e \\ &+ \frac{1}{2}e^T P L \tilde{d} + \frac{1}{2}\tilde{d}^T L^T P e \end{aligned} \quad (84)$$

Lemma The following inequality holds

$$\frac{1}{2}e^T L \tilde{d} + \frac{1}{2}\tilde{d}^T L^T P e - \frac{1}{2\rho^2}e^T PLL^T P e \leq \frac{1}{2}\rho^2 \tilde{d}^T \tilde{d} \quad (85)$$

Proof The binomial $(\rho a - \frac{1}{\rho} b)^2$ is considered. Expanding the left part of the above inequality one gets

$$\begin{aligned} \rho^2 a^2 + \frac{1}{\rho^2} b^2 - 2ab &\geq 0 \Rightarrow \frac{1}{2} \rho^2 a^2 + \frac{1}{2\rho^2} b^2 - ab \geq 0 \Rightarrow \\ ab - \frac{1}{2\rho^2} b^2 &\leq \frac{1}{2} \rho^2 a^2 \Rightarrow \frac{1}{2} ab + \frac{1}{2} ab - \frac{1}{2\rho^2} b^2 \leq \frac{1}{2} \rho^2 a^2 \end{aligned} \tag{86}$$

The following substitutions are carried out: $a = \tilde{d}$ and $b = e^T PL$ and the previous relation becomes

$$\frac{1}{2} \tilde{d}^T L^T P e + \frac{1}{2} e^T P L \tilde{d} - \frac{1}{2\rho^2} e^T P L L^T P e \leq \frac{1}{2} \rho^2 \tilde{d}^T \tilde{d} \tag{87}$$

Equation (87) is substituted in Eq. (84) and the inequality is enforced, thus giving

$$\dot{V} \leq -\frac{1}{2} e^T Q e + \frac{1}{2} \rho^2 \tilde{d}^T \tilde{d} \tag{88}$$

Equation (88) shows that the H_∞ tracking performance criterion is satisfied. The integration of \dot{V} from 0 to T gives

$$\begin{aligned} \int_0^T \dot{V}(t) dt &\leq -\frac{1}{2} \int_0^T \|e\|_Q^2 dt + \frac{1}{2} \rho^2 \int_0^T \|\tilde{d}\|^2 dt \Rightarrow \\ 2V(T) + \int_0^T \|e\|_Q^2 dt &\leq 2V(0) + \rho^2 \int_0^T \|\tilde{d}\|^2 dt \end{aligned} \tag{89}$$

Moreover, if there exists a positive constant $M_d > 0$ such that

$$\int_0^\infty \|\tilde{d}\|^2 dt \leq M_d \tag{90}$$

then one gets

$$\int_0^\infty \|e\|_Q^2 dt \leq 2V(0) + \rho^2 M_d \tag{91}$$

Thus, the integral $\int_0^\infty \|e\|_Q^2 dt$ is bounded. Moreover, $V(T)$ is bounded and from the definition of the Lyapunov function V in Eq. (74) it becomes clear that $e(t)$ will be also bounded since $e(t) \in \Omega_e = \{e | e^T P e \leq 2V(0) + \rho^2 M_d\}$.

According to the above and with the use of Barbalat’s Lemma one obtains $\lim_{t \rightarrow \infty} e(t) = 0$.

Robust State Estimation with the Use of the H_∞ Kalman Filter

A Kalman Filter for the linearized model of the induction motor that is given in Eq. (55) can be designed to cope with

the case of maximum errors of some linear combination of states for worst case assumptions of process noise, measurement noise and disturbances. This can be useful in state estimation for the induction motor, as a method for model uncertainty compensation. Filters designed to minimize a weighted norm of state errors are called H_∞ or minimax filters [28, 29].

The discrete-time H_∞ filter uses the same state-space model as the Kalman Filter, which has the form

$$\begin{aligned} x(k+1) &= A(k)x(k) + B(k)u(k) + w(k) \\ z(k) &= C(k)x(k) + v(k) \end{aligned} \tag{92}$$

$E[w(k)] = 0$, $E[w(k)w(k)^T] = Q(k)\delta_{ij}$, $E[v(k)] = 0$, $E[v(k)v(k)^T] = R(k)\delta_{ij}$ and $E(w(k)v(k)^T) = 0$. The update of the state estimate is again given by

$$\hat{x}(k) = \hat{x}^-(k) + K(k)(z(k) - C(k)\hat{x}^-(k)) \tag{93}$$

that minimizes the trace of the covariance matrix of the state vector estimation error

$$J = \frac{1}{2} E\{\tilde{x}(k)^T \cdot \tilde{x}(k)\} = \frac{1}{2} tr(P^-(k)) \tag{94}$$

where $\tilde{x}^-(k) = x(k) - \hat{x}^-(k)$ and $P^-(k) = E[\tilde{x}^-(k)^T \cdot \tilde{x}^-(k)]$. The H_∞ filtering approach defines first a transformation

$$d(k) = L(k)x(k) \tag{95}$$

where $L(k) \in R^{n \times n}$ is a full rank matrix. The use of the transformation given in Eq. (95) allows certain combinations of states to be given more weight than others. Next, defining the estimation error variable $\tilde{d}_1(i) = d(i) - \hat{d}(i)$, the cost function of the H_∞ filter is initially formulated as

$$\begin{aligned} J(k) &= \sum_{i=0}^{k-1} \tilde{d}^T(i+1)^T S(i) \tilde{d}(i+1) / b \\ b &= \tilde{x}^-(0)^T P^-(0)^{-1} \tilde{x}^-(0) \\ &+ \sum_{i=0}^{k-1} w^T(i+1) Q(i+1)^{-1} w(i+1) \\ &+ \sum_{i=0}^{k-1} v^T(i) R(i)^{-1} v(i) \end{aligned} \tag{96}$$

where S_i is a positive-definite symmetric weighting matrix. It can be observed that both matrices $S(k)$ and $L(k)$ appear in the cost function and thus affect the solution $\hat{x}^-(k+1)$ of the optimization problem. The objective is to find state vector estimates $\hat{x}^-(k)$ and $\hat{x}(k)$ that keep the cost function below a given value $1/\theta$ for worst case conditions, i.e.

$$J(k) < \frac{1}{\theta} \quad (97)$$

By rewriting Eq. (96) and substituting Eq. (92) a modified cost functional is obtained

$$J_a(k) = -\frac{1}{\theta} \tilde{x}^-(0)^T P^-(0) \tilde{x}^-(0) + \sum_{i=0}^{k-1} \Gamma(i)$$

$$\Gamma(i) = (x(i+1) - \hat{x}^-(i+1))^T W_i(x(i+1) - \hat{x}^-(i+1))$$

$$- \frac{1}{\theta} (w^T(i+1) Q(i+1)^{-1} w(i+1) + (y(i)$$

$$- C(i)x^-(i))^T R(i)^{-1} (y(i) - C(i)x^-(i))) \quad (98)$$

and

$$W(i) = L(i)^T S(i) L(i) \quad (99)$$

This cost function does not include the dynamic model of the system given in Eq. (92) and this is added by using a vector of Lagrange multipliers $\lambda(i+1)$. This gives

$$J(k) = -\frac{1}{\theta} \tilde{x}^-(0)^T P^-(0) \tilde{x}^-(0)$$

$$+ \sum_{i=0}^{k-1} \left(\Gamma_i + 2 \frac{\lambda(i+1)^T}{\theta} \right) (A(i)\hat{x}(i) + B(i)u(i)$$

$$+ w(i) - x(i+1)) + \frac{2\lambda(0)^T}{\theta} x(0) - \frac{2\lambda(0)^T}{\theta} x(0) \quad (100)$$

The cost function of the filter given in Eq. (100) can be used as the basis for the solution. It is aimed to find equations defining $\hat{x}^-(k+1)$, or equivalently a measurement weighting matrix (similar to the Kalman gain matrix), that minimizes the cost for worst case assumptions about $x(0)$, $w(i)$ and $y(i)$. Thus, the optimization objective is formulated as

$$J^*(k) = \min_{x_i} \max_{x(0), w(i), y(i)} J(k) \quad (101)$$

It is noted that the estimation algorithm has knowledge of the output measurement $y(i)$ but no knowledge about the initial conditions of the system $x(0)$ and the process noise $w(i)$. Under this assumption, the estimation should be able to compensate for worst case values for the unknown parameters. This is a game theoretic problem that is solved in two steps.

In the first step of optimization, partial derivatives of $J(k)$ with respect to $x(0)$, $w(i)$ and $\lambda(i)$ are set to zero so as to maximize the cost function of Eq. (100), now being dependant only on the terms $\hat{x}^-(k+1)$ and $y(k)$ which are included in Γ_i . In the second step of optimization, the partial derivatives of $J(k)$ with respect to $\hat{x}^-(k+1)$ and $y(k)$ are set to zero, to obtain a condition for the filter's gain

matrix that minimizes this cost functional. From the optimization conditions $\partial J(k)/\partial x_0 = 0^T$, $\partial J(k)/\partial w(i) = 0^T$, $\partial J(k)/\partial \lambda(i) = 0^T$ ones obtains an expression of $J(k)$ as function of $\hat{x}^-(k+1)$ and $y(k)$. Next, from the optimization conditions $\partial J(k)/\partial \hat{x}^-(i+1) = 0^T$, and $\partial J(k)/\partial y(i) = 0^T$ one obtains the filter's equations.

The recursion of the H_∞ Kalman Filter, for the model of the induction motor, can be formulated again in terms of a *measurement update* and a *time update* part:

Measurement update:

$$D(k) = [I - \theta W(k) P^-(k) + C^T(k) R(k)^{-1} C(k) P^-(k)]^{-1}$$

$$K(k) = P^-(k) D(k) C^T(k) R(k)^{-1} \quad (102)$$

$$\hat{x}(k) = \hat{x}^-(k) + K(k) [y(k) - C \hat{x}^-(k)]$$

Time update:

$$\hat{x}^-(k+1) = A(k)x(k) + B(k)u(k) \quad (103)$$

$$P^-(k+1) = A(k)P^-(k)D(k)A^T(k) + Q(k)$$

where it is assumed that parameter θ is sufficiently small to assure that the term $P^-(k) - \theta W(k) + C^T(k)R(k)^{-1}C(k)$ will be positive definite. When $\theta = 0$ the H_∞ Kalman Filter becomes equivalent to the standard Kalman Filter. It is noted that apart from the process noise covariance matrix $Q(k)$ and the measurement noise covariance matrix $R(k)$ the H_∞ Kalman filter requires tuning of the weight matrices L and S , as well as of parameter θ .

Simulation Tests

The performance of the proposed nonlinear H_∞ control scheme for asynchronous motors is tested in tracking of various setpoints. First setpoints were defined independently for the rotation speed and the magnetic flux of the rotor. Next, based on these values, setpoints for the stator currents i_{sd} and i_{sq} were also computed. As shown in the simulation experiments these setpoints can vary dynamically and even in that case the proposed nonlinear H-infinity controller succeeds the accurate setpoints tracking.

As it can be observed in Figs. 3, 4, 5 the feedback control scheme of the induction motor enabled accurate convergence to the reference setpoints. Yet simple, the considered H_∞ control law succeeded precise tracking of the reference signals. In comparison to feedback control methods for asynchronous motors which are based on exact linearization, the nonlinear H_∞ control requires the solution of an algebraic Riccati equation at each iteration of the control algorithm. The known robustness features of H_∞ control are the ones that permit to compensate for the approximation

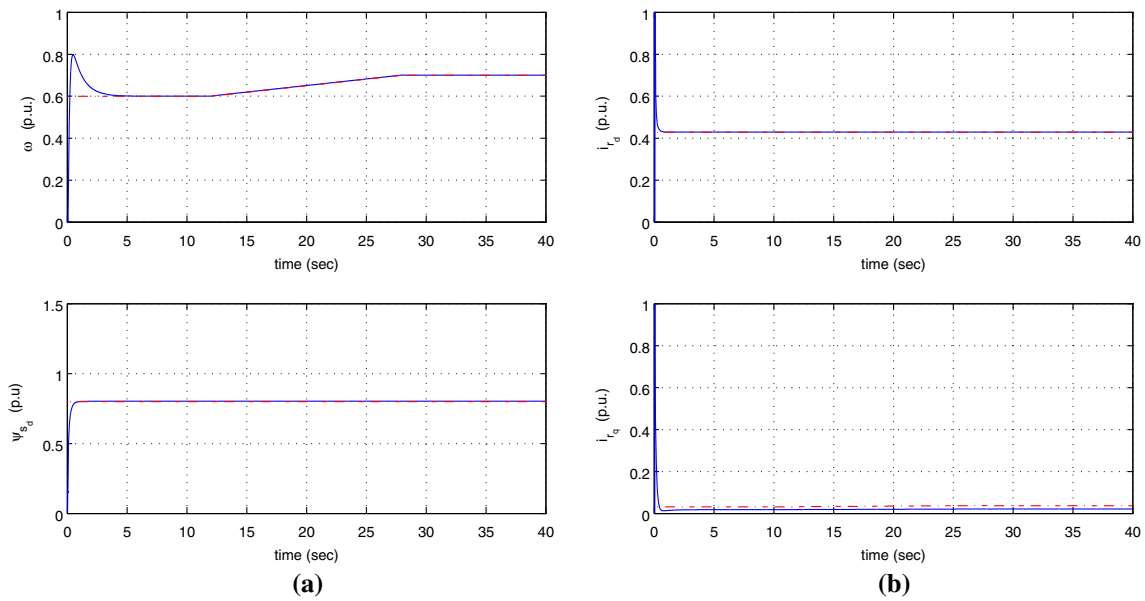

Fig. 3 Nonlinear H_∞ control of the asynchronous motor. **a** Convergence of the rotor’s angular speed ω and stator’s magnetic flux ψ_{sd} to setpoint 1. **b** Convergence of the stator’s currents to the reference setpoints

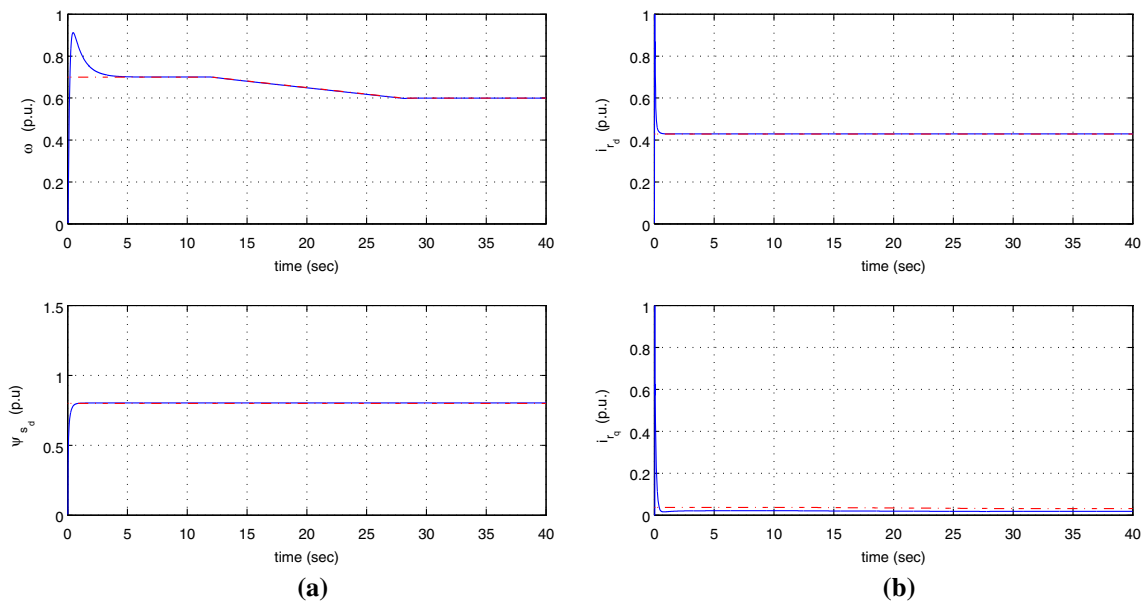

Fig. 4 Nonlinear H_∞ control of the asynchronous motor. **a** Convergence of the rotor’s angular speed ω and stator’s magnetic flux ψ_{sd} to setpoint 2. **b** Convergence of the stator’s currents to the reference setpoints

errors which were induced to the linearized model of the induction motor.

The tracking performance of the control method is shown in Tables 1 and 2. It can be observed that the tracking error for all state variables of the induction motor was extremely small. Besides, in the simulation diagrams one can note the excellent transient performance of the control algorithm, which means that convergence to the reference setpoints was suc-

ceeded in a smooth manner, while also avoiding overshoot and oscillations.

Moreover, the performance of the nonlinear H-infinity control scheme was tested in the case of functioning of the asynchronous motor under disturbances. It was assumed that additive input disturbances affected the induction motor. These were described by sinusoidal voltages of amplitude equal to 10 % of the mean value of the control inputs. The

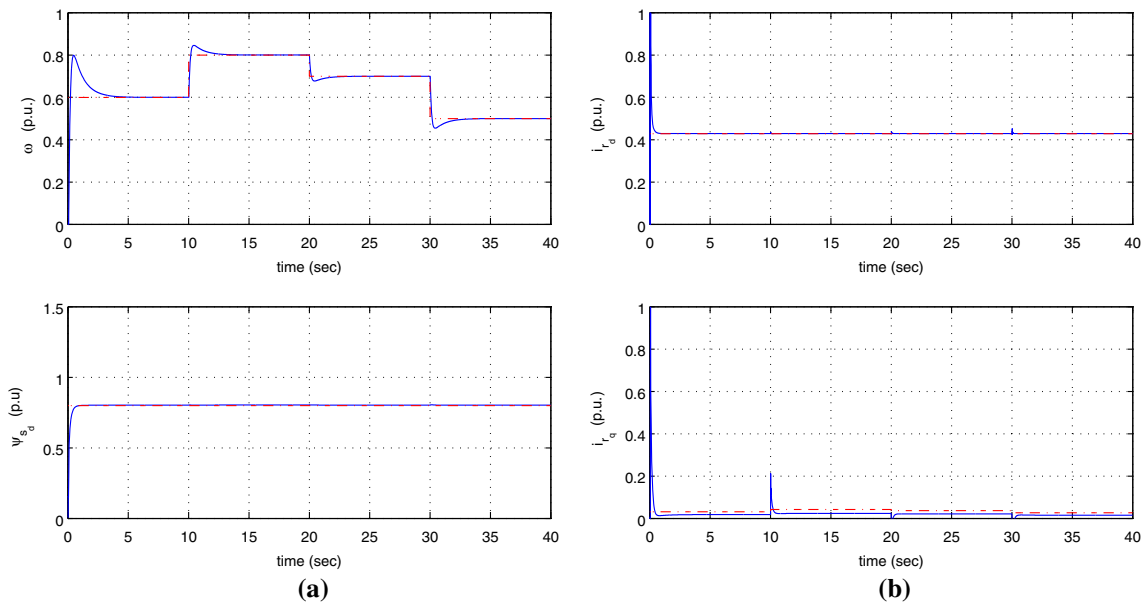

Fig. 5 Nonlinear H_∞ control of the asynchronous motor. **a** Convergence of the rotor’s angular speed ω and stator’s magnetic flux ψ_{sd} to setpoint 3. **b** Convergence of the stator’s currents to the reference setpoints

Table 1 Tracking RMSE without disturbances

	$RMSE_\omega$	$RMSE_{\psi_{rd}}$	$RMSE_{i_{sd}}$
Setpoint ₁	0.0016	0.0032	0.0007
Setpoint ₂	0.0017	0.0030	0.0005

Table 2 Tracking RMSE under disturbances

	$RMSE_\omega$	$RMSE_{\psi_{rd}}$	$RMSE_{i_{sd}}$
Setpoint ₁	0.0060	0.0063	0.0030
Setpoint ₂	0.0047	0.0062	0.0030

obtained results, shown in Table 2, confirm that despite the effects of perturbation inputs the tracking accuracy for the motor’s state variables was satisfactory.

Finally, the suitability of the H-infinity Kalman Filter for estimating non-measurable state variables of the asynchronous motor is shown in Fig. 6. The measured state variables of the motor where $x_1 = \theta$, $x_4 = i_{rd}$ and $x_5 = i_{rq}$. The estimated state variables, which were finally used in the feedback control loop where $\hat{x}_2 = \hat{\omega}$ and $\hat{x}_3 = \hat{\psi}_{rd}$. It can be noticed that, despite the missing sensory information, accurate tracking of the reference setpoints was succeeded.

Remark 1 Comparing the proposed nonlinear H-infinity control approach against backstepping nonlinear control for induction motors one should take into account that backstepping control is a special case of flatness-based control and actually it is a global linearizing method [24, 30, 31]. Thus for

the nonlinear backstepping control of induction motors hold the same remarks which have been state in the introduction of the article, in the comparison between global linearization-based control methods and nonlinear H-infinity control [32]. Yet, conceptually more simple, nonlinear H-infinity control can perform equally well to global linearization-based control methods. On the other hand, it should be noted that backstepping control is applicable to a limited class of systems, that is systems written in the integral backstepping (triangular) form. Consequently, the proposed nonlinear H-infinity control method is applicable to a wider range of electric machines and traction systems.

Remark 2 Comparing the proposed nonlinear H-infinity control approach against sliding mode controllers and sliding-mode observers for induction machines, it can be noted that the latter control and estimation approaches exhibit specific drawbacks. First, due to the use of a switching control term, sliding-mode controllers and sliding-mode observers exhibit chattering which means vibratory dynamics and an undesirable transient performance for the control loop [33]. On the other hand, H-infinity control succeeds smooth variations of the control input and good transient characteristics for the control loop. Second, in sliding-mode control it is necessary to know beforehand the uncertainty boundaries for the system’s dynamics. Unlike this, in the design of H-infinity control no such assumption is made while the suitable selection of the attenuation coefficient ρ appearing in the Riccati Eq. (70) can finally provide the control loop with maximum robustness to model uncertainty and external perturbations.

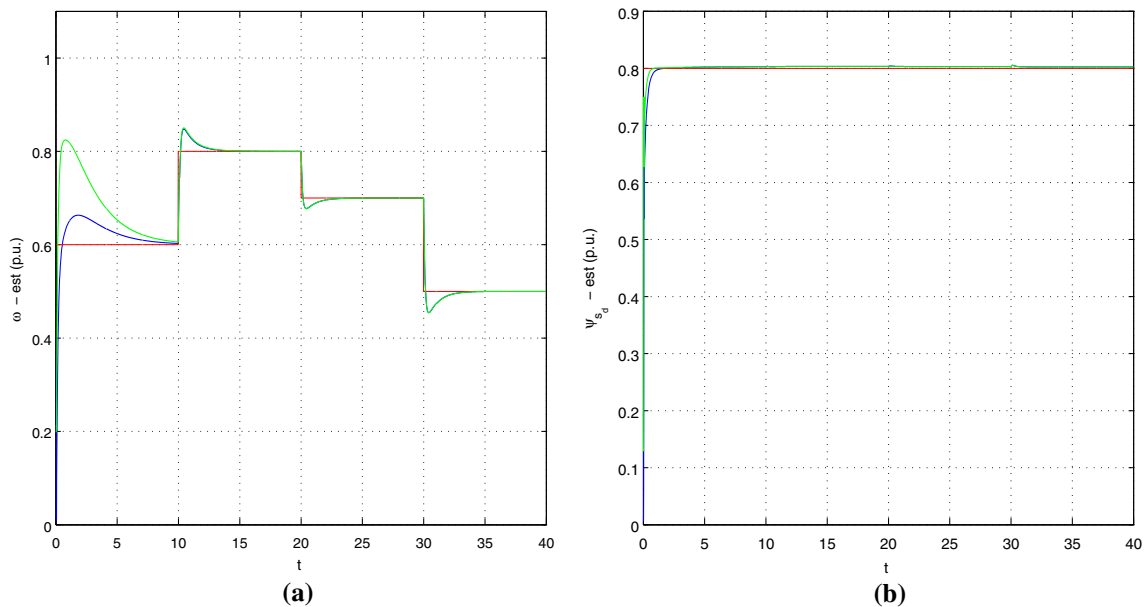

Fig. 6 Nonlinear H-infinity control of the asynchronous motor through estimation of non-measurable state variables with the use of the H-infinity Kalman Filter. **a** Estimation (green line) of state variable $x_2 = \omega$

(blue line) and convergence to the reference setpoint (red line). **b** Estimation (green line) of state variable $x_3 = \psi_{rd}$ (blue line) and convergence to the reference setpoint (red line)

Conclusions

A new nonlinear feedback control method has been developed for induction motors, based on approximate linearization and the use of H_∞ control and stability theory. It has been shown that the proposed induction motor control scheme enables the state vector elements of the electrical machine to track accurately all reference setpoints. The first stage of the proposed control method is the linearization of the motor's dynamic model using first order Taylor series expansion and the computation of the associated Jacobian matrices. The errors due to the approximative linearization have been considered as disturbances that affect, together with external perturbations, the motor's model.

At a second stage the implementation of H_∞ feedback control has been proposed. Using the linearized model of the induction motor an H-infinity feedback control law is computed at each iteration of the control algorithm, after previously solving an algebraic Riccati equation. The known robustness features of H-infinity control enable to compensate for the errors of the approximative linearization, as well as to eliminate the effects of external perturbations. The efficiency of the proposed control scheme for induction motors is shown analytically and is confirmed through simulation experiments.

Comparing to other nonlinear control methods which are based on the exact linearization of the electrical machine's model it can be stated that the proposed H_∞ control uses the approximately linearized model of the induction motor without implementing elaborated state transformations (dif-

feomorphisms) that finally bring the system to a linear form. Of course the computation of Jacobian matrices and the need to solve at each iteration of the algorithm a Riccati equation is also a computationally cumbersome procedure, especially for state-space models of large dimensionality. Moreover, this approximate linearization introduces additional perturbation terms which the H_∞ controller has to eliminate. The continuous need for compensation of such cumulative linearization errors brings the H_∞ controller closer to its robustness limits.

References

1. Guzinski, J., Abu-Rud, H., Dignes, M., Krzeminski, Z., Lewicki, A.: Speed and load torque observer application in high-speed train electric drive. *IEEE Trans. Ind. Electr.* **57**(2), 565–574 (2010)
2. Guzinski, J., Dignes, M., Krzeminski, Z., Lewicki, A., Abu-Rud, H.: Application of speed and load torque observer in high-speed train drive for diagnostic purposes. *IEEE Trans. Ind. Electr.* **56**(1), 248–256 (2009)
3. Shibaya, H., Kondo, K.: Designing methods of capacitance and control system for a diesel engine and EDLC hybrid powered railway traction system. *IEEE Trans. Ind. Electr.* **58**(9), 4232–4240 (2011)
4. Derada, D., Merbaki, A., Gerada, C., Cavagnino, A., Boglietti, A.: High-speed electrical machines: technologies, trends and developments. *IEEE Trans. Ind. Electr.* **61**(6), 2946–2959 (2014)
5. Marino, R., Scalzi, S., Tomei, P., Verrelli, C.M.: Fault-tolerant cruise control of electric vehicles with induction motors. *Control Eng. Pract.* **21**, 860–869 (2013). (Elsevier)
6. Ciccarelli, F., Ianuzzi, D., Tricoli, P.: Control of metro-train equipped with on-board supercapacitors for energy saving and

- reduction of power peak demand. *Transp. Res. Part C* **24**, 36–49 (2012). (Elsevier)
7. Gao, S., Dong, H., Chen, Y., Ning, B., Chen, G., Yang, X.: Approximation-based robust adaptive automatic train control: an approach for actuator saturation. *IEEE Trans. Intell. Transp. Syst.* **14**(4), 1733–1742 (2013)
 8. Zhuang, X., Xiu, X.: Speed regulation with measured output feedback in the control of heavy haul trains. *Automatica* **44**, 242–247 (2008). (Elsevier)
 9. Holtz, J.: Sensorless control of induction motor drives. *Proc. IEEE* **90**(8), 1359–1394 (2002)
 10. Rigatos, G.G.: Adaptive fuzzy control of DC motors using state and output feedback. *Electric Power Syst. Res.* **79**(11), 1579–1592 (2009). (Elsevier)
 11. Rigatos, G.G.: Adaptive fuzzy control for field-oriented induction motor drives. *Neural Comput. Appl.* **21**(1), 9–23 (2011). (Springer)
 12. Lin, F.J., Wai, R.J., Lin, C.H., Liu, D.C.: Decoupled stator-flux-oriented induction motor drive with fuzzy neural network uncertainty observer. *IEEE Trans. Ind. Electr.* **47**(2), 356–367 (2000)
 13. Nounou, H.N., Rehman, H.: Application of adaptive fuzzy control to AC machines. *Appl. Soft Comput.* **7**(3), 899–907 (2007). (Elsevier)
 14. Bodson, M., Chiasson, J., Novotnak, R.: High-performance induction motor control via input–output linearization. *IEEE Control Syst. Mag.* **2**, 24–33 (1994)
 15. Georges, D., De Wit, C., Ramirez, J.: Nonlinear H_2 and H_∞ optimal controllers for current-fed induction motors. *IEEE Trans. Autom. Control* **44**(7), 1430–1435 (1999)
 16. Marino, R., Peresada, S., Valigi, P.: Adaptive input-output linearizing control of induction motors. *IEEE Trans. Autom. Control* **38**(2), 208–221 (1993)
 17. Marino, R., Peresada, S., Tomei, P.: Global adaptive output feedback control of induction motors with uncertain rotor resistance. *IEEE Trans. Autom. Control* **44**(5), 967–983 (1999)
 18. Chiasson, J.: A new approach to dynamic feedback linearization control of an induction motor. *IEEE Trans. Autom. Control* **43**(3), 391–397 (1998)
 19. Wai, R.J., Chang, J.M.: Implementation of robust wavelet-neural-network sliding-mode control for induction servo motor drive. *IEEE Trans. Ind. Electr.* **50**(6), 1317–1334 (2003)
 20. Wai, R.J., Chang, H.H.: Backstepping wavelet neural network control for indirect field-oriented induction motor drive. *IEEE Trans. Neural Netw.* **15**(2), 367–382 (2004)
 21. Brdys, M.A., Kulowski, G.J.: Dynamic neural controllers for induction motor. *IEEE Trans. Neural Netw.* **10**(2), 340–355 (1999)
 22. Rigatos, G.: *Modelling and Control for Intelligent Industrial Systems: Adaptive Algorithms in Robotics and Industrial Engineering*. Springer, New York (2011)
 23. Rigatos, G.: *Advanced Models of Neural Networks: Nonlinear Dynamics and Stochasticity in Biological Neurons*. Springer, New York (2013)
 24. Rigatos, G.: *Nonlinear Control and Filtering Using Differential Flatness Theory Approaches: Applications to Electromechanical Systems*. Springer, Switzerland (2015)
 25. Rigatos, G.G., Tzafestas, S.G.: Extended Kalman filtering for fuzzy modelling and multi-sensor fusion. *Math. Comp. Model. Dyn. Syst.* **13**, 251–266 (2007). (Taylor & Francis)
 26. Basseville, M., Nikiforov, I.: *Detection of Abrupt Changes: Theory and Applications*. Prentice-Hall, Upper Saddle River (1993)
 27. Rigatos, G., Zhang, Q.: Fuzzy model validation using the local statistical approach. *Fuzzy Sets Syst.* **60**(7), 882–904 (2009). (Elsevier)
 28. Gibbs, B.P.: *Advanced Kalman Filtering, Least Squares and Modelling: A Practical Handbook*. Wiley, New York (2011)
 29. Simon, D.: A game theory approach to constrained minimax state estimation. *IEEE Trans. Signal Process.* **54**(2), 405–412 (2006)
 30. Traoré, D., De Leon, J., Glumineau, A.: Sensorless induction motor adaptive observer-backstepping controller: experimental robustness tests on low frequencies benchmark. *IET Control Theory Appl.* **4**(10), 1989–2002 (2010)
 31. Kwan, C.M., Lewis, F.L.: Robust backstepping control of induction motors using neural networks. *IEEE Trans. Neural Netw.* **11**(5), 1178–1187 (2000)
 32. Rigatos, G., Siano, P., Zervos, N.: A new concept on flatness-based control of nonlinear dynamical systems. In: *IEEE INDIN 2015, 4th International Conference on Industrial Informatics*, Cambridge, July 2015
 33. Ghanes, M., Zheng, G.: On sensorless induction motor drives: sliding mode observer and output feedback controller. *IEEE Trans. Ind. Electr.* **56**(9), 3404–3413 (2009)