

Long-term structural performance monitoring system for the Shanghai Tower

Jia-Zhan Su · Yong Xia · Lu Chen · Xin Zhao · Qi-Lin Zhang ·
You-Lin Xu · Jie-Min Ding · Hai-Bei Xiong · Ru-Jin Ma ·
Xi-Lin Lv · Ai-Rong Chen

Received: 13 September 2012/Revised: 27 December 2012/Accepted: 28 December 2012/Published online: 24 January 2013
© Springer-Verlag Berlin Heidelberg 2013

Abstract The Shanghai Tower, currently being constructed in Shanghai, China, is a supertall building with a height of 632 m. The Shanghai Tower will be the tallest skyscraper in China after its completion. This structure consists of a core wall inner tube, an outer mega-frame, and a total of six levels of outriggers that connect the tube and the frame. The structure needs comprehensive full-scale investigation to understand its structural performance when subjected to dead loads, strong winds, earthquakes, and temperatures, given its supertall height and complex structural configuration. A sophisticated structural performance monitoring system that consists of more than 400 sensors is designed for both in-construction and in-service real-time monitoring of the skyscraper. This paper reports the structural system and provides details on the performance of the monitoring system. The key features of the monitoring system are the following: (1) simultaneous installation of sensors and data acquisition systems with structural construction to record initial values; (2) measurement of structural settlement and displacement at different construction stages; (3) direct measurement of wind loads on structure facades through 27 wind pressure

sensors; (4) measurement of structural inclination and derivation of structural sway at different heights using 40 inclinometers. Preliminary monitoring data, which include deformation and strain/stress up to the present construction stage, are also presented and discussed.

Keywords Supertall building · Mega-frame-core-wall structural system · Structural performance monitoring

1 Introduction

Numerous supertall buildings have been built across the world in the past decades to meet the economic and social needs of communities, especially in Asia. The new generation of supertall buildings is designed to be more flexible, slender, and visually exciting, which pose special challenges for their safety and performance. Numerical analysis and scaled laboratory experiments have been conducted to predict the structural performance of supertall buildings under various loading conditions. However, the performance of supertall buildings under actual construction and service conditions is a key issue that has not been comprehensively investigated because of the current shortage of existing, sufficient, and mature experience with regard to practical supertall buildings. Therefore, the structural performance should be monitored in real-time to ensure the safety and serviceability during the construction and service stages.

The recently developed structural health monitoring (SHM) technology offers excellent solutions in measuring the loading environment and response mechanisms and provides real-time information on extreme events that may affect operation, serviceability, or safety reliability [1, 2]. The applications of the SHM system to building structures are less widespread compared with numerous case studies

J.-Z. Su · Y. Xia (✉) · Y.-L. Xu
Department of Civil and Environmental Engineering,
The Hong Kong Polytechnic University, Hong Kong SAR,
People's Republic of China
e-mail: ceysxia@polyu.edu.hk

L. Chen · Q.-L. Zhang · H.-B. Xiong · R.-J. Ma · X.-L. Lv ·
A.-R. Chen
College of Civil Engineering, Tongji University, Shanghai,
People's Republic of China

X. Zhao · J.-M. Ding
Tongji Architectural Design (Group) Co. Ltd., Shanghai,
People's Republic of China

and successful implementations and operations of SHM to bridges [10, 18].

Majority of the monitoring conducted on tall buildings (or towers) has been aimed at measuring the loading environment and response mechanisms for strong winds and earthquakes by mounting advanced sensors. For instance, Brownjohn et al. [3] established a long-term monitoring program for a 280 m high 65-story office tower in Singapore to monitor structural dynamic responses and track structural performance during and after construction. A full-scale measurement of acceleration responses on a 70-story building in Hong Kong under strong typhoons was conducted [11]. The results of the measurement were compared with wind tunnel model results to identify wind-induced structural response characteristics. Similar full-scale measurements of acceleration responses were conducted for the 200 m high Guangdong International Building [12] and the 420.5 m high Jin Mao Tower [13], which are both in mainland China. A monitoring program consisting of advanced sensors and information technologies was investigated to validate the observed full-scale performances of three tall buildings in Chicago against wind tunnel and finite element (FE) models [8, 9]. According to previous studies, more than 160 buildings in California, USA, more than 100 buildings in Japan, and more than 40 buildings in Taiwan have been equipped with strong-motion monitoring systems for seismic response measurements and post-earthquake damage assessments [6, 7, 14]. An SHM system consisting of over 800 sensors was implemented for both in-construction and in-service real-time monitoring of the 600 m high Canton Tower (previously the Guangzhou New TV Tower) [16, 17, 19].

The construction stage of a complex supertall structure is critical because imperfections during the construction stages lead to additional stress and permanent deformation in the service stage. Although numerical analysis has been widely utilized to predict the mechanical behavior of structures during construction, systematic monitoring during the construction of supertall buildings is still limited. The 632 m high Shanghai Tower presented in this paper provides researchers an opportunity to gain a comprehensive understanding of the structural performance of the building when subjected to strong winds, harsh temperatures, and earthquakes during and after construction. A sophisticated SHM system consisting of approximately 400 sensors is designed and then implemented for the skyscraper for both in-construction and in-service monitoring.

This paper mainly focuses on the structural system and the SHM system of the Shanghai Tower. Preliminary monitoring data, including deformation and strain/stress during several constructional stages, are presented. The practical monitoring exercise described in this paper provides the designer, the contractor, and the researcher with

valuable real-time data in terms of structural performance during construction.

2 Shanghai Tower

The Shanghai Tower, currently being constructed near the 421 m tall Jin Mao Tower and the 492 m tall Shanghai World Financial Center, is a supertall building with a structural height of 580 m and an architectural height of 632 m. The Shanghai Tower will be the tallest structure in China upon completion in 2014 (Fig. 1a).

A triangular outer façade encloses the entire structure, which gradually shrinks and twists clockwise at approximately 120° along the height of the building. The building is divided into nine zones along its height separated by eight independent strengthening floors (Fig. 1b). The building will be used for office spaces, entertainment facilities, hotel and sky-gardens, as well as various retail and cultural venues [4].

The Shanghai Tower adopts a mega-frame core-wall structural system, which comprises a core wall inner tube, an outer mega-frame, and a total of six levels of outriggers between the tube and the frame (Fig. 2). The outriggers are set along the height of the building at zones 2, 4, 5, 6, 7, and 8. Post-grouting bored piles are employed for the foundation of the structure.

2.1 Core wall inner tube system

The inner core wall tube is square-shaped with dimensions of $30\text{ m} \times 30\text{ m}$ divided into nine cells at the bottom of the building. The core wall changes along the height of the building. The four corners of the square core wall are partially removed at zone 5 and then further removed to be a cross arrangement (five cells) at zone 7 before forming a rectangle (three cells) at the top of the tube (Fig. 3). The thickness of the core wall varies from 1.2 m at the bottom of the building to the minimum of 0.5 m at the top. Steel plates are embedded in the flange and web walls of the core tube from the bottom of the building to form composite shear walls, which reduce wall thickness and improve ductility. C60 grade concrete, in accordance with the Chinese code [5], is used for the core wall.

2.2 Outer mega-frame system

The mega-frame consists of eight super columns, four corner columns, radial trusses, and two-story high-box belt trusses (Fig. 4). The eight super columns extend to zone 8, whereas the four corner columns extend to zone 5. The four corner columns are designed mainly to reduce the spans of the box belt trusses below zone 6. All columns gradually

Fig. 1 Shanghai Tower

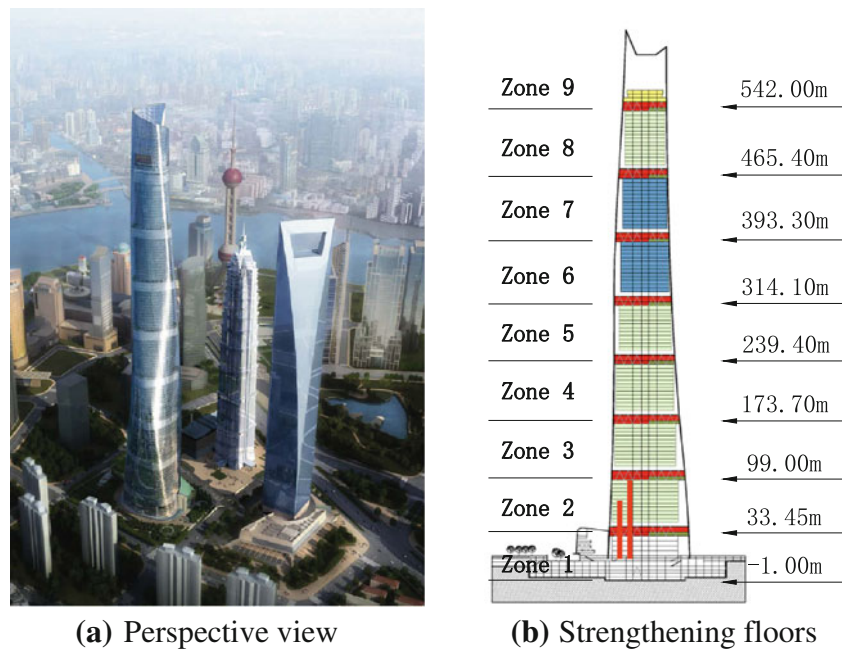
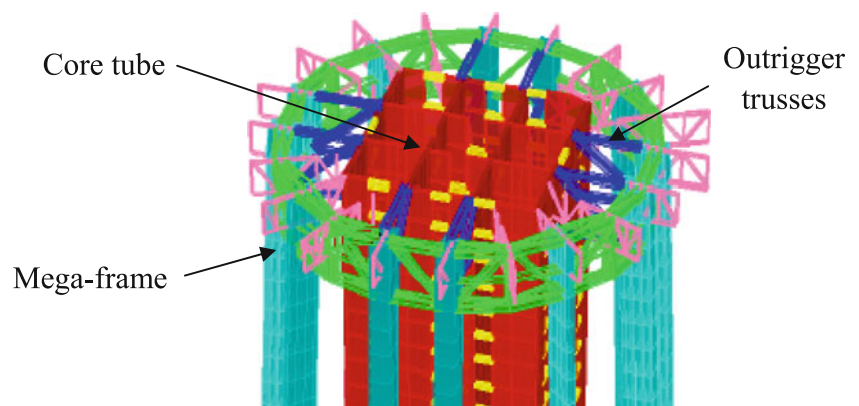

Fig. 2 Structural components



incline in a vertical direction toward the center of the core tube. The maximum dimensions of the super columns decrease from 5.3 m × 4.3 m at the underground level to the minimum of 2.4 m × 1.9 m at the top of the columns. Radial trusses are installed at the strengthening floors of each zone to support a twisting double-layered glass curtain wall system around the entire building. A total of eight two-story high-box belt trusses in each zone are designed as transferring trusses to improve the moment of resistance of the columns effectively.

2.3 Floor system

A standard floor plan in zone 2 is shown in Fig. 5. The standard floor is made of a composite deck with profiled steel sheets as the permanent bottom formwork for the reinforced concrete slabs. The inner layer glass curtain wall is set along the periphery of the floor slabs, whereas the outer layer attaches to the radial trusses.

3 Structural performance monitoring system

The strains and stresses at critical components, the deflection and settlement of the entire structure, and the structural performance of the building under extreme loadings during construction and service stages of this complex structure are the main concerns of the designer, the contractor, and the client.

A sophisticated structural performance monitoring system is being installed to monitor the performance of the building during both construction and service stages. This system will ensure that construction errors in the structure will be within the allowable limit specified in the design. The in-construction monitoring system will be extended for the in-service monitoring after completion of structure.

The SHM system for the Shanghai Tower has been devised in accordance with the modular design concept, which is in practical operation in the Tsing Ma Suspension Bridge [20] and the Canton Tower [17]. The in-construction

Fig. 3 Cross sections of the core tube

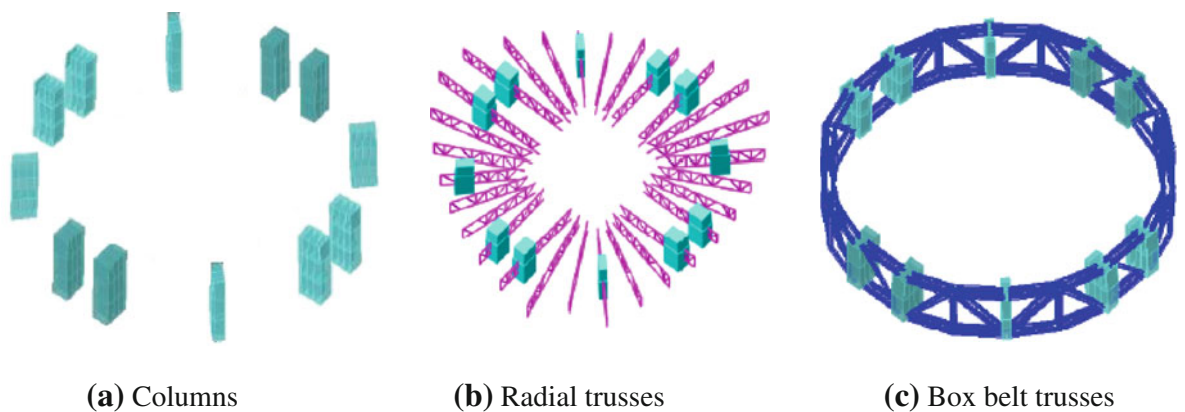
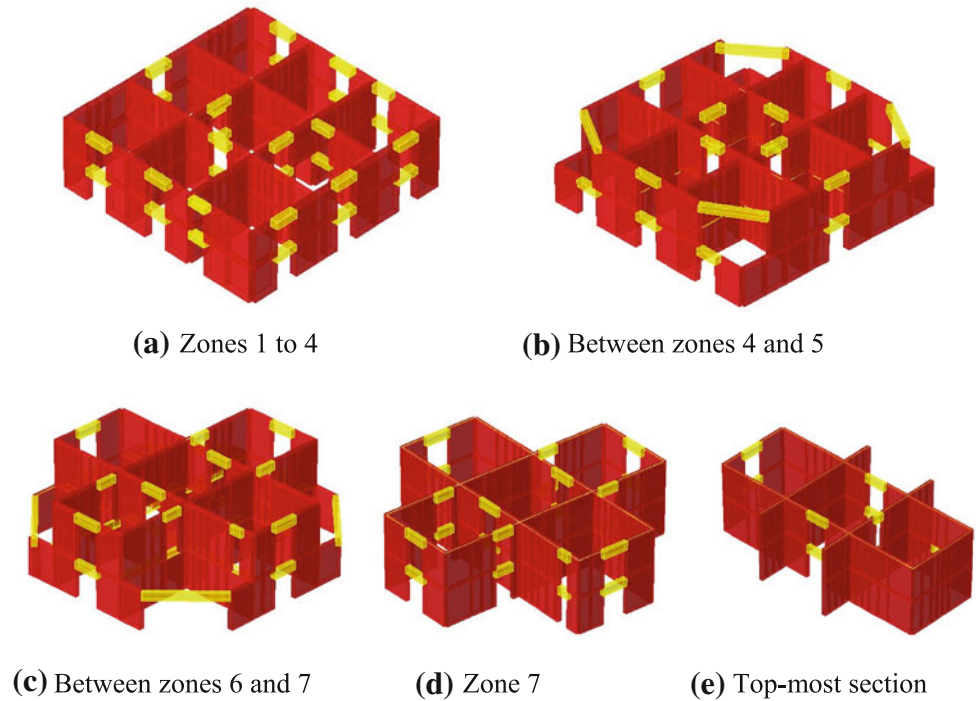

Fig. 4 Components of the mega-frame

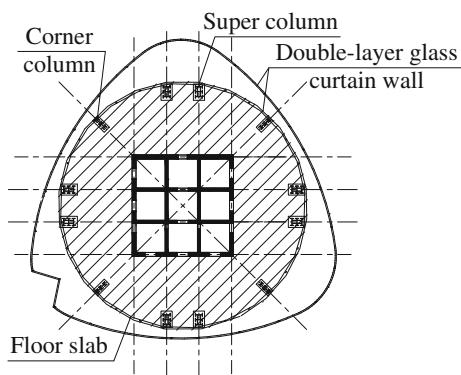

Fig. 5 Standard floor plan of the Shanghai Tower

monitoring system consists of four modules: sensory system, data acquisition and transmission system, data processing and control system, and structural performance evaluation system.

The sensory system is responsible for collecting raw data from various sensors. The sensory system consists of more than 400 sensors with 11 different types (Table 1). These sensors are deployed to monitor three categorical parameters: loadings (wind pressure, structural temperature, and earthquake), structural responses (settlement, inclination, displacement, strain, and acceleration), and environmental effects (ambient temperature and wind). The layout of the sensors is illustrated in Fig. 6.

Table 1 Sensors deployed in the monitoring system

No.	Sensor type	Monitoring items	Number of sensors
1	Seismograph	Earthquake motion	2
2	Anemometer	Wind speed and direction	1
3	Wind pressure sensor	Wind pressure	27
4	Accelerometer	Acceleration	71
5	Inclinometer	Structural inclination	40
6	Thermometer	Air and structural temperature	75
7	Strain gauge	Strain	209
8	Global positioning system	Displacement	3
9	Total station	Displacement, leveling, and settlement	2
10	Digital level	Leveling of floors	1
11	Digital video camera	Displacement	1
Total			432

All these sensors are selected to capture important information about the static and dynamic properties of the structure. The sensors are installed at crucial locations according to the FE analysis results of the partial structures at different construction stages and the entire structure. In addition, the accuracy of the measurement for specific structural responses can be improved by combining multiple types of sensors and data. For example, a video camera, global positioning system (GPS), and total station are deployed to measure the horizontal displacement at the top of the structure at various stages of construction for cross-calibration. Another example is the combination of GPS, accelerometers, and a series of inclinometers to achieve a reliable measurement of static and dynamic displacement.

The data acquisition and transmission system consists of 11 stand-alone sub-stations (Fig. 6), which are distributed along cross-sections at different heights of the building to collect signals from surrounding sensors. The real-time data acquired from the sensors are transmitted from the sub-stations to the site monitoring central room wirelessly during in-construction monitoring. The wireless system is replaced by a wired cabling system during the service stage to guarantee long-term monitoring.

The data processing and control system is composed of a high-performance computer system and data processing software, and is located in the monitoring central room to control sub-stations for data acquisition and pre-processing, data transmission and filing, and data management and displaying.

The structural performance evaluation system is composed of a condition evaluation system and a structural

performance and safety assessment system. The condition evaluation system is mainly utilized to evaluate the structural condition promptly through comparisons of the static and dynamic measurement data with design parameters, FE model analysis results, and pre-determined threshold values. The functions of the structural performance and safety assessment system include, but are not limited to, construction stage analysis, structural analysis, parameter sensitivity analysis, structural identification, FE model modification, and warning. The basic procedure of the monitoring system is shown in Fig. 7.

The structural performance monitoring system for the Shanghai Tower integrates both in-construction and in-service monitoring. This integrated monitoring system enables the tracking of complete data histories from the onset of structural construction. In particular, the strain gauge can monitor total strain rather than relative strain, which is necessary for evaluating the real performance index of the structural components under extreme loading events. These factors reflect the merit of the integrated monitoring system, which acquires complete monitoring data from the construction stage to the service stage.

4 FE model

As described in Sect. 3, the performance monitoring system can track the changes in strain responses as well as measure the deflection of the building at different stages of construction. Corresponding FE models were constructed to predict the changing trends, compare with field measurement results, and then verify the effectiveness of the evolution of the monitoring data.

FE models were established using a general FE analysis software package MIDAS/GEN [15] according to actual completed structural components during construction. Photographs of the building at four different construction stages and their corresponding FE models are shown in Fig. 8.

The core wall inner tube of the building was constructed earlier than the outer mega-frame and floor of the building, in accordance with the construction schedule. The completed core wall is higher than the outer frame to provide space and allow the four cranes attached to the core wall to lift structural components into place (see Fig. 8).

5 Settlement, levelness, and horizontal displacement monitoring

The increase in the settlement of foundations and compression deformation between upper floors are from the increasing deadweight during the construction of supertall

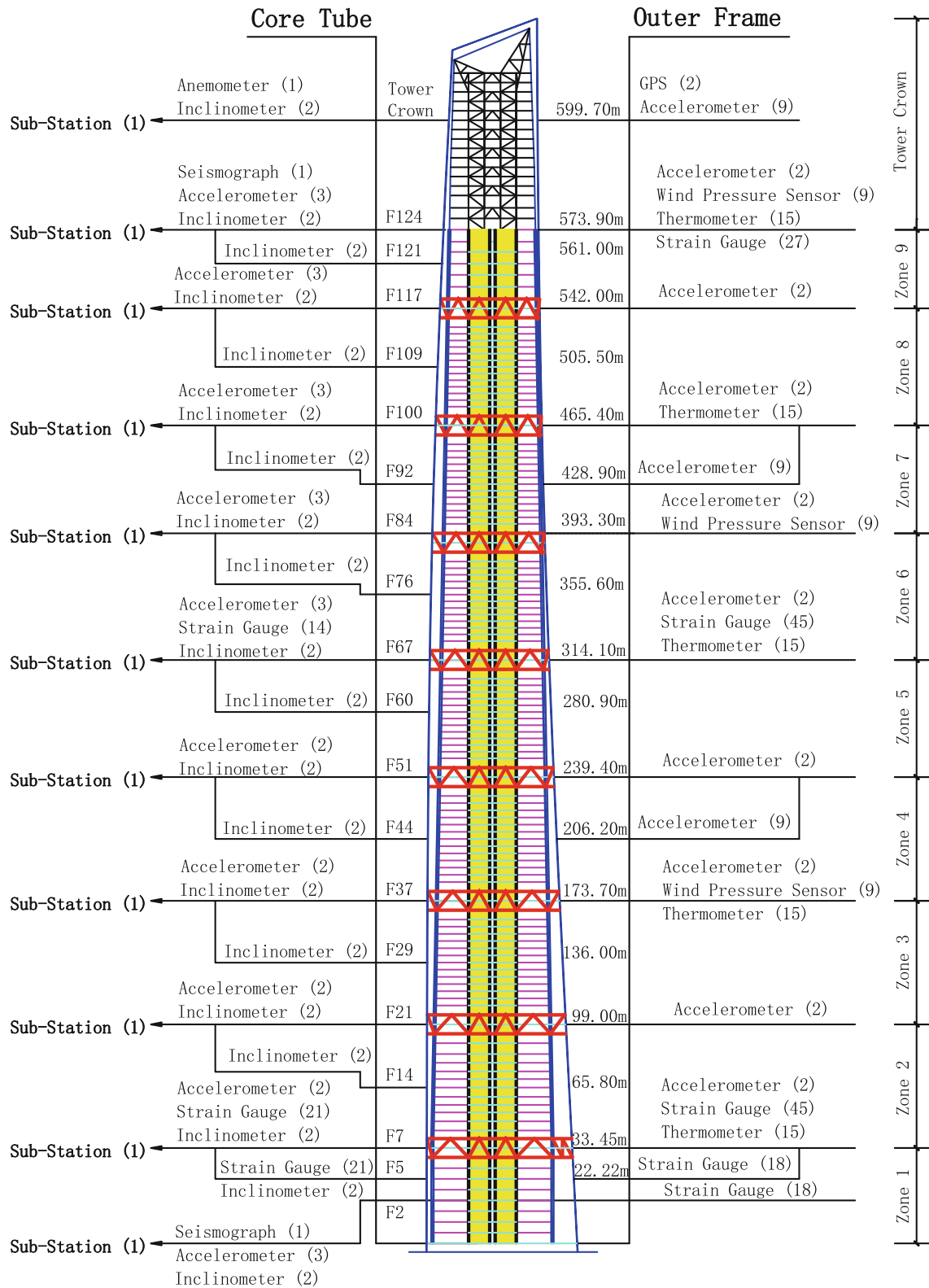
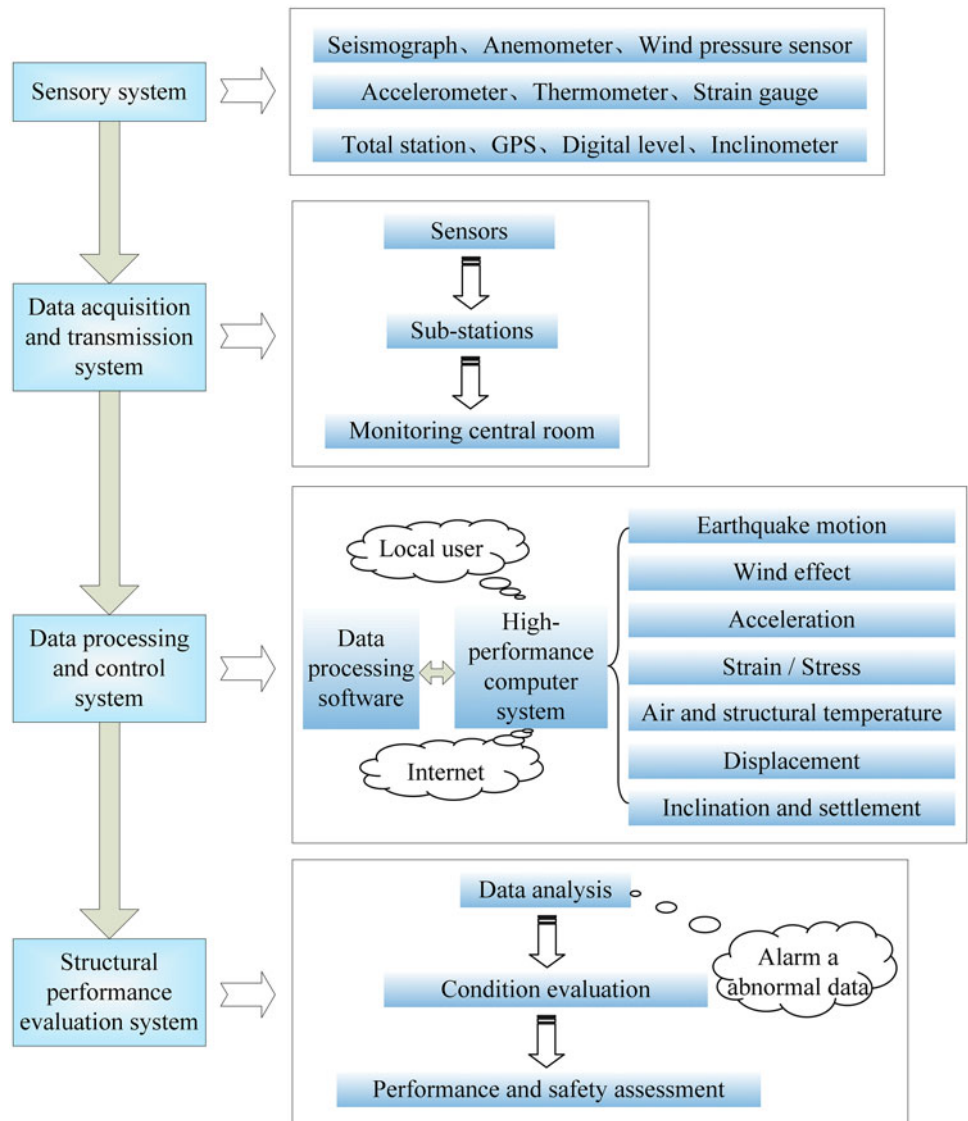

Fig. 6 Sensor layout of the monitoring system

buildings. Non-uniform settlement or excessive settlement may induce instability during construction. In addition, the elevation of the floors after completion of the structure has

to meet design requirements. Therefore, it is necessary to timely measure and analyze the trends in foundation settlement, predict the settlement of upper floors and identify

Fig. 7 Basic procedure of the monitoring system



the maximum difference, and revise the prediction values afterward.

A total station and a digital level are employed to monitor the elevation of the foundation floor and the upper floors. Floor elevation at control points are measured from the foundation floor to the upper floors, in which a total station is used as the transit station. In addition, a series of points at the monitoring floor around the core wall and super columns serves as reference points for measuring the relative settlement and levelness of the upper floors. As a result, the real settlement of the upper monitoring floor is obtained from its relative settlement plus the settlement of the foundation floor. The settlement of the foundation floor provides an important reference value for evaluating the prearranged height of the floor elevation afterward. The measurement should be carried out during stable wind and temperature conditions to minimize the influence of

environmental factors and thereby improve measurement precision.

The locations of elevation measurement points at each monitoring floor are shown in Fig. 9. The total settlement of the measurement points at the foundation floor at different construction stages is shown in Fig. 10. The results show that the changing trend of the settlement at different locations is basically consistent. In addition, the total settlement values are generally in close agreement with a difference of 8 mm, which indicates that the foundation has no significant non-uniform settlement.

The elevations of the upper monitoring floors are measured relative to the foundation floor. The relative settlement of the core wall (from July 2011 to May 2012) and super columns (from October 2011 to May 2012) at the 4th floor are shown in Table 2. The compression of the core wall and the super columns between the foundation floor

Fig. 8 Photographs of the Shanghai Tower and the corresponding FE models at different construction stages

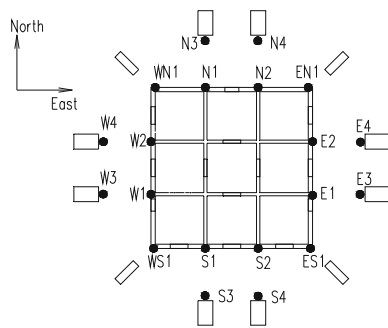

Fig. 9 Elevation measurement points at each key floor

and the 4th floor stays at a relatively small value; the levelness of the floor meets the construction requirements.

The horizontal displacement at the top of the structure during construction and inter-story drifts under wind and temperature actions should be controlled within allowable ranges. GPS stations and a total station are combined to measure the horizontal displacement at the top of the structure (Fig. 11). One GPS station is placed on the ground as the reference station, and two GPS rover stations

are installed at the top of the structure. Movements of the inner tube in two horizontal directions and rotation along the center can then be calculated. A high-precision automated total station is used for verification.

The total station data collected on 19 October 2011 are analyzed in this paper to examine the temperature-induced horizontal displacement at the top of the structure at a construction height of 180 m. Air temperature variations during 6:30 a.m. to 5:00 p.m. is illustrated in Fig. 12. Air temperature reached its peak value (about 25.5 °C) at about 11:30 a.m. and then gradually dropped in the afternoon. Overall, the horizontal displacement increased toward the south–southeast direction with the rise in temperature from 6:30 a.m. The horizontal displacement had a maximum value of approximately 30 mm at 11:30 a.m., and then decreased when the temperature began to drop (Fig. 13).

A number of tall buildings, including the 421 m tall Jin Mao Tower and the 492 m tall Shanghai World Financial Center, flank the Shanghai Tower. The tall buildings around the Shanghai Tower induce a multipath effect on GPS signals. Moreover, the four cranes at the top of the

Fig. 10 Foundation settlement of the inner tube

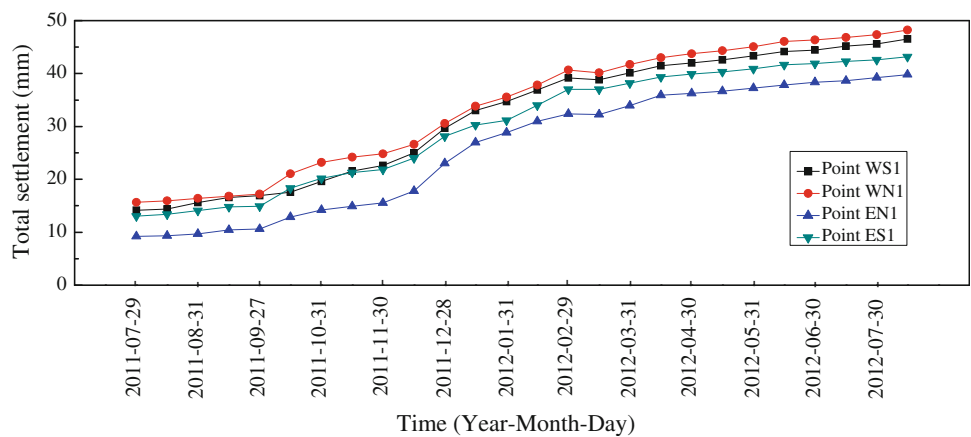

Table 2 Relative settlement of the core wall and the super column at the 4th floor

Structure	Measurement point no.	Settlement (mm)	Measurement point no.	Settlement (mm)
Core wall	ES1	13.5	WS1	12.0
	E1	12.9	S1	12.8
	E2	11.7	S2	10.3
	EN1	11.7	WN1	10.4
	N1	9.7	W1	11.4
	N2	11.9	W2	9.0
Super column	E3	6.5	S3	4.5
	E4	7.2	S4	6.3
	N3	3.9	W3	3.9
	N4	5.8	W4	6.5

the construction site to evaluate the accuracy of the measurement using GPS real-time kinematic surveying. In the test, a permanent point on the ground, which was located approximately 200 m away from the structure, was selected as the reference station. The rover station was fixed in a stable position at the top of the core wall inner tube (about 180 m high) to measure its position in real time while exposed to a weak wind. During the test, the GPS rover station did not receive enough satellite signals. In addition, the precision of the horizontal direction was beyond 2 cm, an indication that the cranes at the top and the tall buildings around the Shanghai Tower affected the accuracy of the GPS signal.

Shanghai Tower may block satellite signals going to the GPS rover stations. The number of available satellites and their geometric distribution are key factors that affect the precision of position. Therefore, one test was conducted at

6 Strain/stress monitoring

The strain in the different components of the structure is continuously monitored during construction to evaluate the safety of the structure and to monitor structural stress levels. The strain at floors 2, 5, 7, 67, and 124 is monitored

Fig. 11 Combination of total station and GPS for displacement measurement

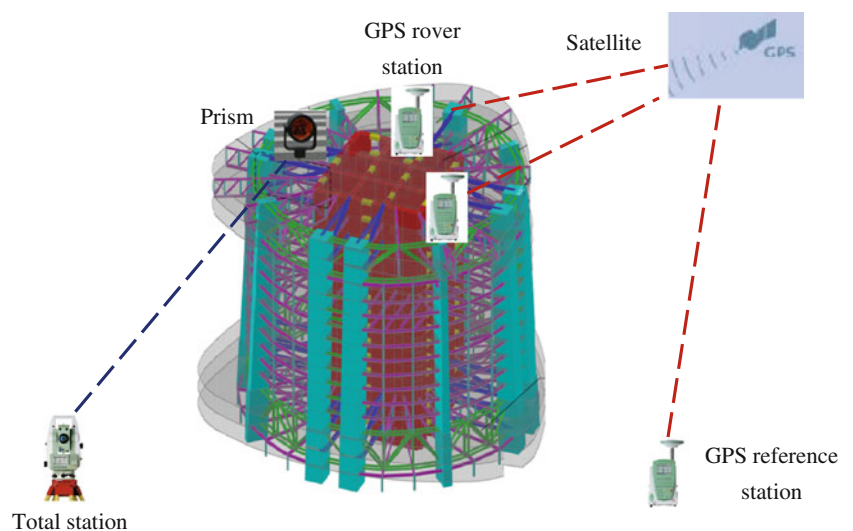

Fig. 12 Variations in air temperature on 19 Oct. 2011

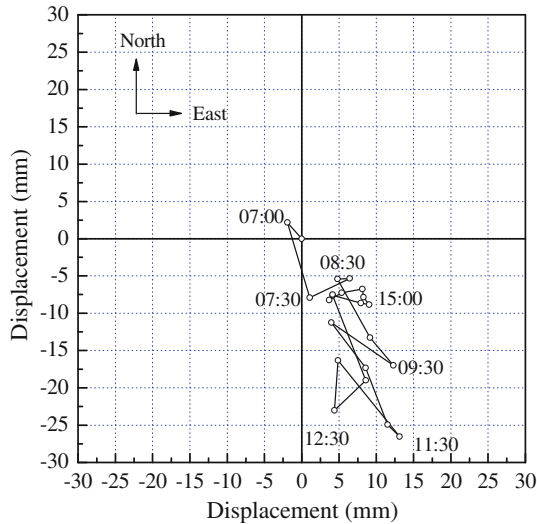
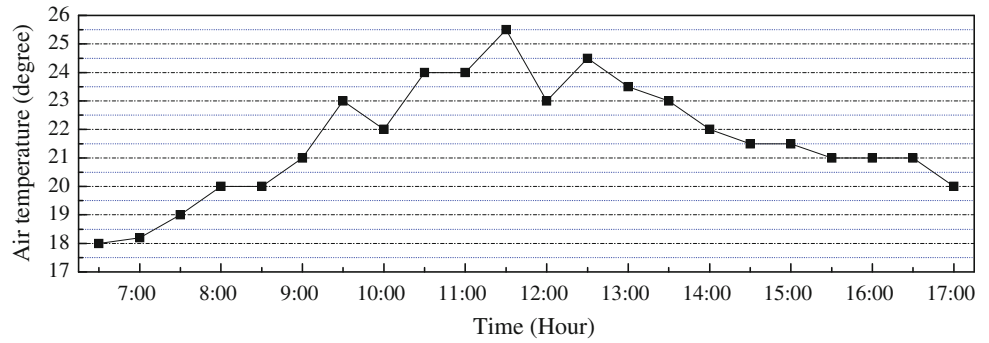

Fig. 13 Horizontal movement of the top of the structure on 19 Oct. 2011

(Fig. 6). The plan position of the strain gauges is shown in Fig. 14. Strain gauges for the inner tube are installed on three sections (floors 5, 7, and 67). Strain gauges for the outer mega-frame are embedded in the super columns on four sections (floors 2, 5, 7, and 67). Strain gauges for the outrigger trusses are installed on three sections (floors 7,

67, and 124). The detailed positions of the strain gauges are shown in Fig. 15.

Vibrating wire strain gauges were embedded before the concrete was poured to measure the strain of the concrete. The strain and temperature of each sensor vary during the hydration and initial shrinkage stages after pouring the concrete. The strain and temperature can be regarded as initial values when readings are stable.

The strain of the sensors embedded in the concrete component includes the strain induced by external force, shrinkage, and creep strain of the concrete. The shrinkage and creep strain can be calculated using available equations or site measurements [19]. Afterward, stresses of the structure are calculated from the net strain measurement by multiplying the modulus, under the assumption that the components are mainly in a uniaxial stress state.

The evolution of stress at the surface of the embedded steel plates in the inner tube is shown in Fig. 16. The compressive stresses gradually increase along with construction progress. The stresses at all points are rather small compared with the material strength. The changing trend of stress from the field measurements are in agreement with the FE model predictions, although some discrepancy exist between them. The discrepancy may be due to the following factors: (1) components may be subjected to 3D

Fig. 14 Location of strain monitoring points in a typical cross-section

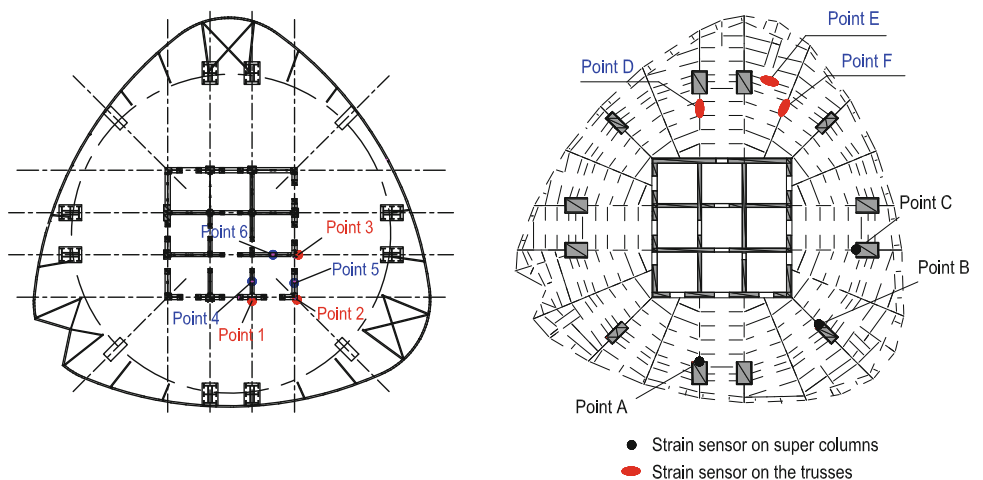

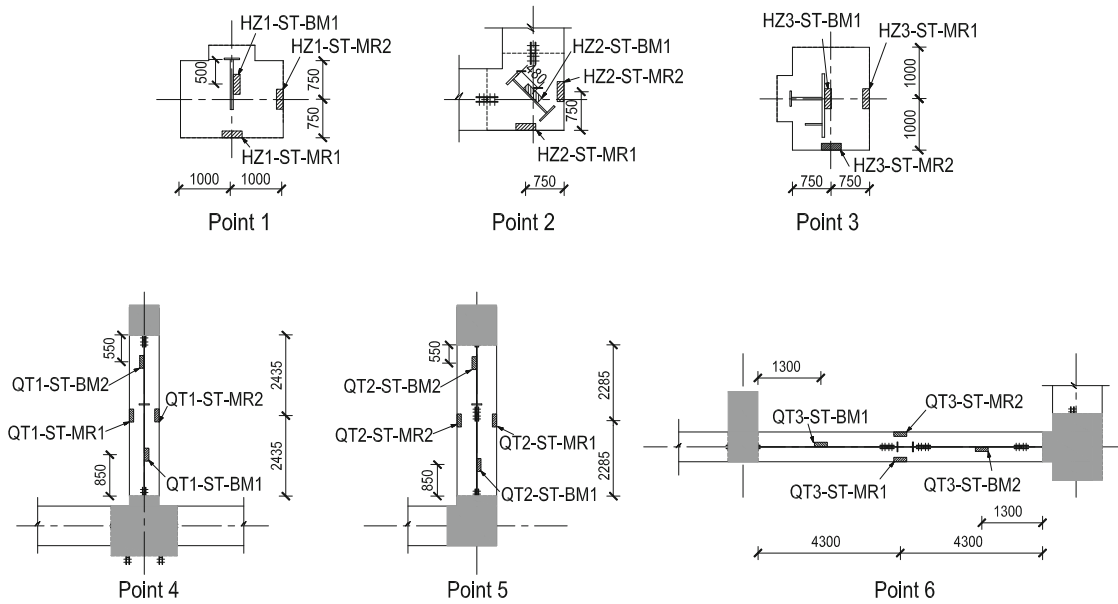

(a) Strain gauges on the inner tube

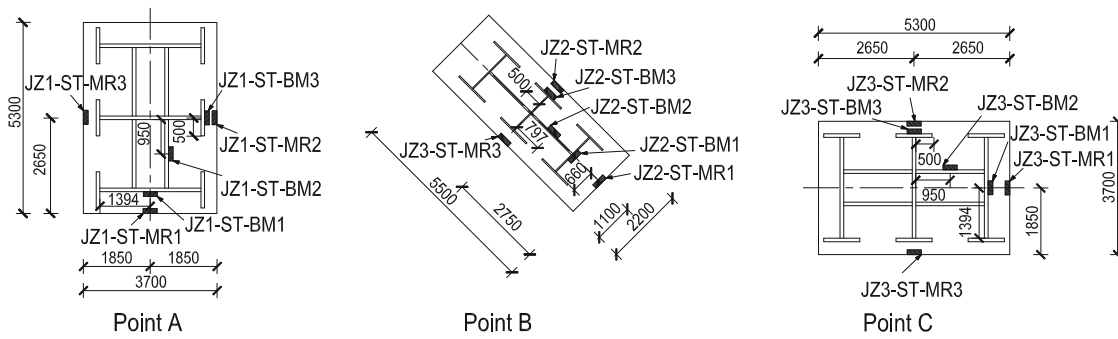

(b) Strain gauges on super columns

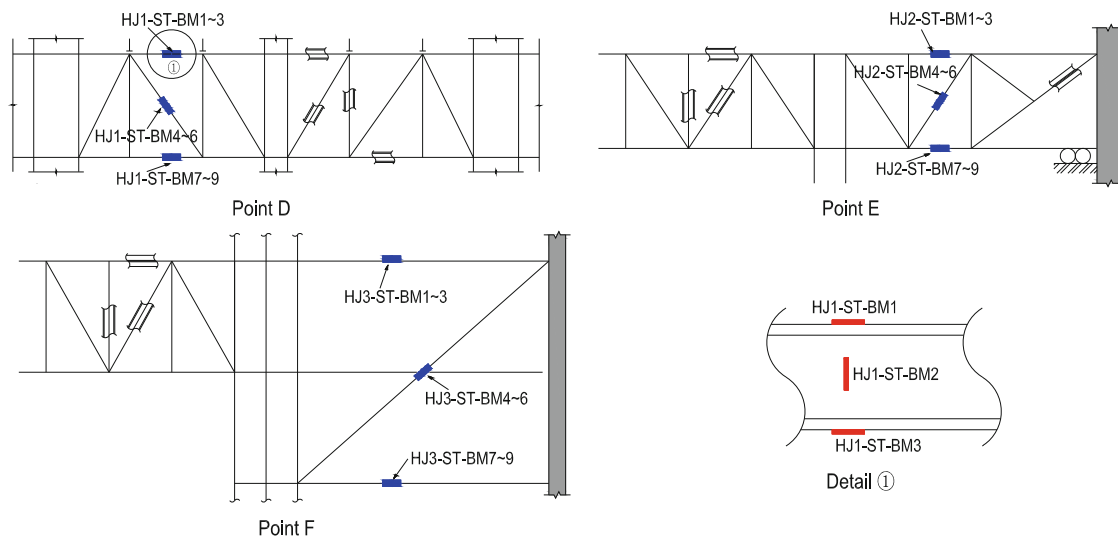

(c) Strain gauges on outrigger trusses

Fig. 15 Location of strain gauges on structural components (mm)

Fig. 16 Stress evolution at different construction stages at the 5th floor

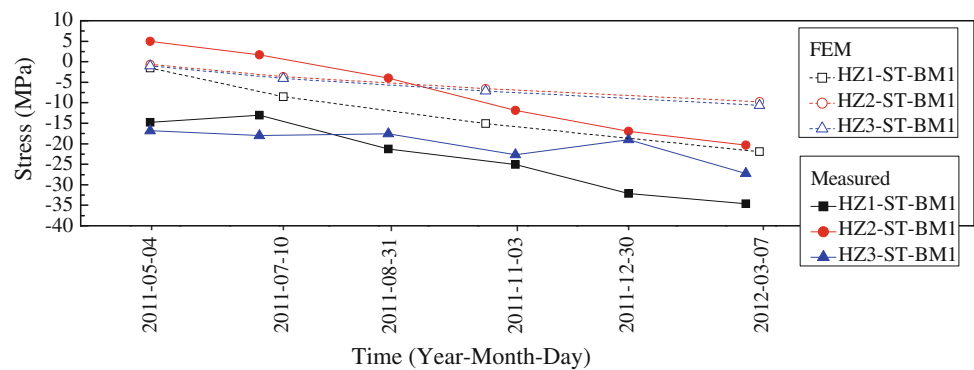

stress states; however, measurements were only made in 1D; (2) non-uniform temperature distribution throughout the structure results in thermal stresses at the components; (3) measurement noise.

7 Other monitoring items

Wind loading is one of the critical loads on a supertall building. Wind pressure fluctuations in the windward and leeward faces from fluctuations in wind velocity and its interaction with the building result in along-wind motion for the building. Moreover, wind loads on a group of supertall buildings in a real environment are different from those on an isolated building, which is a special problem that needs to be taken into account for the Shanghai Tower. Therefore, the accurate evaluation and measurement of wind loads are very important to understand the effects of wind on this supertall structure.

An anemometer is placed at the top of the structure to monitor the speed and direction of the wind. A series of 27 wind pressure sensors is installed on the double-layered glass curtain wall to measure the wind loads acting on the façades of the structure directly. The wind pressure sensors are placed around the outer curtain wall at floors 37, 84, and 124.

Important structural criteria for the detailed analysis of the displacement of supertall buildings not only include the horizontal displacements at the top of structure but also the inter-story drifts at different heights under wind and seismic loadings. Considering that the Shanghai Tower has eight independent strengthening floors, the inter-story drifts at different heights may exhibit a complex profile rather than a simple shear type, flexural type, or flexural–shear type. In this regard, each of the 20 sections along the height of the building will be equipped with two inclinometers in the shear walls of the inner tube. The inclination of the structure at two perpendicular directions will be measured in real-time. The structural sway or inter-story drifts at different heights can then be derived through integration.

The horizontal displacement at the structural top will be compared with the GPS measurement.

8 Conclusions

This paper discusses a sophisticated structural performance monitoring system designed for the Shanghai Tower, the tallest skyscraper in China. Preliminary monitoring data, including vertical settlement, levelness, horizontal displacement, and strain/stress, are presented and discussed. The 1-year monitoring exercise during the construction stage shows the satisfactory performance of the strain sensors and the data acquisition system. The long-term monitoring system provides an opportunity for the comprehensive investigation of the structural performance of supertall buildings during actual construction and service conditions.

In the present project, the sensors and data acquisition systems were simultaneously installed with structural construction such that the initial structural responses were recorded. After the construction completes, the measurement data will be transferred to the service stage. The integration of the in-construction and in-service monitoring systems enables life-cycle monitoring and assessment of the structure from its ‘birth’.

Acknowledgments This work is jointly supported by the Research Grants Council of the Hong Kong Special Administrative Region, China (Project No. PolyU 5285/12E) and the Hong Kong Construction Industry Institute/PolyU Innovation Fund (Project No. 5-ZJD3).

References

- Aktan AE, Catbas FN, Grimmelsman KA, Tsikos CJ (2000) Issues in infrastructure health monitoring for management. *J Eng Mech ASCE* 126(7):711–724
- Brownjohn JMW, Pan TC (2008) Identifying loading and response mechanisms from ten years of performance monitoring of a tall building. *J Perform Constr Facil ASCE* 22(1):24–34
- Brownjohn JMW, Pan TC, Cheong HK (1998) Dynamic response of Republic Plaza, Singapore. *Struct Eng* 76(11):221–226

4. Ding JM, Zhao X, Chao S (2010) The Shanghai Tower. In: Conference on structural marvels, Singapore, 13–14 Dec
5. GB 50010 (2002) Code for design of concrete structures. National Standard of People's Republic of China, Beijing (in Chinese)
6. Huang MJ (2006) Utilization of strong-motion records for post-earthquake damage assessment of buildings. In: Proceedings of the international workshop on structural health monitoring and damage assessment, Taichung, Taiwan, 14–15 Dec, pp IV1–IV29
7. Huang MJ, Shakal AF (2001) Structure instrumentation in the california strong motion instrumentation program. *Strong Motion Instrum Civil Eng Struct* 373:17–31
8. Kijewski-Correa T, Kareem A (2003) The Chicago monitoring project: a fusion of information technologies and advanced sensing for civil infrastructure. In: Wu ZS, Abe M (eds) *Structural health monitoring and intelligent infrastructure*. Balkema, Lisse, pp 1003–1010
9. Kijewski-Correa T, Kilpatrick J, Kareem A, Kwon DK, Bashor R, Kochly M, Young BS, Abdelrazaq A, Galsworthy J, Isyumov N, Morrish D, Sinn RC, Baker WF (2006) Validating wind-induced response of tall buildings: synopsis of the Chicago full-scale monitoring program. *J Struct Eng (ASCE)* 132(10):1509–1523
10. Ko JM, Ni YQ (2005) Technology developments in structural health monitoring of large-scale bridges. *Eng Struct* 27:1715–1725
11. Li QS, Fang JQ, Jeary AP, Wong CK, Liu DK (2000) Evaluation of wind effects on a supertall building based on full-scale measurements. *Earthq Eng Struct Dynam* 29:1845–1862
12. Li QS, Wu JR, Liang SG, Xiao YQ, Wong CK (2004) Full-scale measurements and numerical evaluation of wind-induced vibration of a 63-story reinforced concrete tall building. *Eng Struct* 26:1779–1794
13. Li QS, Xiao YQ, Fu JY, Li ZN (2007) Full-scale measurements of wind effects on the Jin Mao Building. *J Wind Eng Ind Aerodyn* 95:445–466
14. Lin CC, Wang CE, Wang JF (2003) On-line building damage assessment based on earthquake records. In: The first international conference on structural health monitoring and intelligent infrastructure, Tokyo, Japan, 13–15 Nov, pp 551–559
15. MIDAS GEN (2012) Analysis manual for MIDAS/GEN. MIDAS Information Technology Co. Ltd., Seoul, Korea
16. Ni YQ, Wong KY, Xia Y (2011) Health checks through landmark bridges to sky-high structures. *Adv Struct Eng* 14(1):103–119
17. Ni YQ, Xia Y, Liao WY, Ko JM (2009) Technology innovation in developing the structural health monitoring system for Guangzhou New TV Tower. *Struct Control Health Monit* 16(1): 73–98
18. Sohn H, Farrar CR, Hemez FM, Shunk DD, Stinemates DW, Nadler BR, Czarnecki JJ (2004) A review of structural health monitoring literature form 1996–2001. Los Alamos National Laboratory report LA-13976-MS
19. Xia Y, Ni YQ, Zhang P, Liao WY, Ko JM (2011) Stress development of a super-tall structure during construction: field monitoring and numerical analysis. *Comput Aided Civil Infrastruct Eng* 26(7):542–559
20. Xu YL, Xia Y (2012) *Structural health monitoring of long-span suspension bridges*. Spon Press, London