



The Process of Info-Autopoiesis – the Source of all Information

Jaime F. Cárdenas-García¹ 

Received: 13 December 2019 / Accepted: 22 April 2020 / Published online: 15 May 2020
© Springer Nature B.V. 2020

Abstract

All information results from a process, intrinsic to living beings, of info-autopoiesis or information self-production; a sensory commensurable, self-referential feedback process immanent to Bateson's 'difference which makes a difference'. To highlight and illustrate the fundamental nature of the info-autopoietic process, initially, two simulations based on one-parameter feedback are presented. The first, simulates a homeostatic control mechanism (thermostat) which is representative of a mechanistic, cybernetic system with very predictable dynamics, fully dependent on an external referent. The second, simulates a homeorhetic process, inherent to biological systems, illustrating a self-referenced, autonomous system. Further, the active incorporation/interference of viral particles by prokaryotic cells and the activation of CRISPR-Cas can be understood as info-autopoiesis at the most fundamental cellular level, as well as constituting a planetary network of self-referenced information. Moreover, other examples of the info-autopoietic nature of information are presented to show the generality of its applicability. In short, info-autopoiesis is a recursive process that is sufficiently generic to be the only basis for information in nature: from the single cell, to multi-cellular organisms, to consideration of all types of natural and non-natural phenomena, including tools and artificial constructions.

Keywords Gregory Bateson · Science of Information · Info-autopoiesis · Homeostasis · Homeorhesis

✉ Jaime F. Cárdenas-García
jfcg@umbc.edu

¹ Department of Mechanical Engineering, University of Maryland – Baltimore County, 1000 Hilltop Circle, Baltimore, MD 21250, USA

Introduction

I think that tastes, odors, colors, and so on. . .
 reside in consciousness. Hence if the living
 creature were removed, all these qualities
 would be wiped away and annihilated.
 —GALILEO GALILEI.

Gregory Bateson is well known for defining information as *a difference which makes a difference* (Bateson 1978, 453). Such a succinct and deceptively simple definition is certainly subject to possible misinterpretation. One such misinterpretation might involve suggesting that it is a circuitous, self-referential play on the word *difference*. Indeed, the dictionary definition of difference in the Merriam-Webster Online Collegiate Dictionary¹ does not seem to add much clarity, yielding: (i) the quality or state of being dissimilar or different; and (ii) an instance of being unlike or distinct in nature, form, or quality. Rather, it might even suggest that anything is a difference. So indeed, at first glance we seem to be in a logical quandary and great confusion. To seek clarity, we need to better define the context in which an assessment of difference is required.

At the centre of determination of difference is the organism-in-its-environment (O/E), i.e., all living beings. For us humans, sometimes we are faced with looking at very complex differences such as the ones we might experience in looking and analysing an abstract painting. This task may challenge our ability to discern differences in various dimensions and guises of differences. Luckily for us, that is not where we begin our process of distinguishing differences. We start our process of distinguishing differences at the time of our conception as living beings. How does the single human cell know how to become two cells? What is the process of distinguishing differences that then leads to a further division to four cells and so on, until the emergence of the child from the womb, to begin an additional gestation period out of the womb? What is/are the spatial/temporal difference(s) that this cumulative composite of cells detects that allows this certain process to become effective? I am not a biologist so I do not want to delve into all of the biological complexity that probably plays a role. But I do want to assert that at some point in this process our five primary senses (touch, sight, hearing, smell and taste) come on line 24/7. This is the only basis for our access to the world. One thing that can be said with certainty about our senses is that they are functioning continuously, consciously or unconsciously, to detect spatial and/or temporal differences in our dynamic environment. Their functioning is central to our continued existence. In the initial period of gestation out of the womb, our senses help us to sound the alarm to be nurtured when hungry and held close for warmth, but we are possibly unaware that that is the reason why we are doing it.

To begin the journey of determining differences using our five primary senses, it is important to note that our senses deal with commensurable quantities/qualities, i.e., quantities/qualities that have a common measure. For example, the sense of touch (whose multidimensional structure includes mechanoreceptors, thermoreceptors,

¹ <https://www.merriam-webster.com/dictionary/difference>

nociceptors, proprioceptors) might be, for simplicity, arbitrarily ascribed as being sensitive only to pressure. In that limited role, our sense of touch is able to keep track of all pressure sensations that come into its sphere of action. As might be imagined, from one instant of time to the next, pressure sensations are felt by the human in question and become part of her experience. This is how quantitatively and unambiguously “a (pressure) difference” becomes qualitatively “a (pressure) difference which makes a difference”. In a similar way, the other dimensions of the sense of touch contribute with their own unique quantitative/qualitative characteristics. Thus, in toto contributing to a multidimensional sensory experience that consists of temporal/spatial differences. This is the process of information that Bateson discovered and is applicable to any and all of our primary senses, which not only act individually but in concert. Our primary senses provide for us our only contact with our environment and are key to our development.

Implicit to this conception of information, applicable to all living beings, is that all information is self-produced. In other words, information is the result of a process of *info-autopoiesis*, or a process of self-production of information by all living beings. A corollary is that there is no information in the environment, except for information produced by living beings.

The neologism *info-autopoiesis* (info = information; auto = self; poiesis = creation, production) is not to be confused with *autopoiesis* (auto = self, poiesis = creation, production) “a word that could directly mean what takes place in the dynamics of the autonomy proper to living systems” (Maturana and Varela 1980: xvii). It is not intended to infer anything about *autopoiesis* (Maturana and Varela 1973, 1980, 1987) beyond sharing the notion of self-production. The use of the neologism *info-autopoiesis* is to refer specifically to the self-production of information. And it is even worth quoting Varela (1981) at length, when referring to autopoiesis,

Our efforts were directed toward showing the following.

- (1) The importance of the individual organization is fundamental, and the autonomous character of the living system takes precedence, both logical and functional, over the genetic understanding of the individual as a member of the species. The individual organization can be shown to be one of self-construction through recursive production of components, and it is this specific organization, autopoiesis, which is at the base of the autonomy of living systems. The most clear paradigm of this autopoietic organization is the cell and its metabolic net. Once the individual organization is clearly defined, one can attempt to analyze the added complexities that autopoietic systems have undergone in the history of Earth, including their reproductive capacities and higher order aggregations.
- (2) ***Informational and functional notions need not enter into the characterization of the living organization (emphasis added)***, as they belong to a domain different from the relations that define the system. Thus we proposed a critique to the current use of such notions as unnecessary for the definition of the logic of life, and claimed autopoiesis as necessary and sufficient to define the living organization, and, a fortiori, the phenomenology of the living. (Varela 1981, 36-37)

Taking Varela at his word, it appears that notions of information are of little interest in the conceptualization of autopoiesis. Varela further notes,

In A(utopoietic)S(systems) we argued that *the notions of information and purpose are dispensable (emphasis added)*. This is because the living organization could be defined without resorting to such notions, and thus, the explanation underlying the living phenomena need not include them as constitutive components. Further, we argued, such notions cannot enter into the definition of a system's organization because they pertain to the domain of discourse between observers. Information and purpose can only enter for pedagogical purposes. They do not enter into an operational explanation, for which autopoiesis is complete, that is, based on distinctions of component properties that generate a phenomonic domain.

In retrospect, I believe this question needs further development (emphasis added). I still hold to be valid the criticism of the naive use of information and purpose as notions that can enter into the definition of a system on the same basis as material interactions ... (Varela 1981, 38)

The author believes that the current work may be used as a point of departure to attempt the inclusion of information into the “dynamics of the autonomy proper to living systems”.

To discuss the process of info-autopoiesis and its implications, this paper is divided into three sections. Firstly, in section 2, a cybernetic simulation of a thermostat illustrates the dynamic nature of info-autopoiesis and is used as a basis for comparison to the versatility of a homeorhetic feedback simulation, and to the CRISPR-Cas system in prokaryotes, and to several examples that differ in scope. Second, in section 3, a brief discussion puts all the pieces together to show how the process of info-autopoiesis is central to information creation. Finally, in section 4, the findings of the paper are summarized and pertinent conclusions are presented.

The Generic Nature of Info-Autopoiesis

It must be considered that there is nothing more difficult to carry out nor more doubtful of success, nor more dangerous to handle, than to initiate a new order of things. For the reformer has enemies in all those who profit by the old order, and only lukewarm defenders in all those who would profit by the new order, this lukewarmness arising partly for fear of their adversaries, who have the laws in their favor; and partly from the incredulity of men, who do not truly believe in anything new until they have had actual experience of it.

Niccolò Machiavelli (1469–1519), *The Prince*, Chapter 6.

Norbert Wiener tautologically states that “Information is information, not matter or energy. No materialism, which does not admit this, can survive at the present day” (Wiener 1948 1961, 132). This is how Wiener accredited that information is a most pervasive and unique element that is abundant in the Universe. Even proposing the widely held perspective that information is a pre-existing and/or third fundamental quantity of the Universe (Wheeler 1990; Stonier 1997; Yockey 2005; Lloyd 2006;

Umpleby 2007; Burgin 2010; Floridi 2011; Vedral 2010). A perspective that is also widely shared in the biosemiotics community (Brier 1999, 2008; Battail 2009, 2013; Barbieri 2012, 2013; Fresco et al. 2018; Jablonka 2002; Queiroz et al. 2008; Patte 2013).

The definition of Bateson information as *a difference which makes a difference* challenges this conception of information. What is widely acknowledged is that matter and/or energy are the only fundamental quantities of the Universe. Further, matter and/or energy are in motion above a temperature of zero degrees absolute. Roughly, in the temperature range in which living beings are abundant, bordering 273 degrees absolute, matter and/or energy are always in motion. Life is abundant in this *Goldilocks Zone* that gets bigger with every new discovery of life in extreme environments. Further, the flourishing of life had much to do with the motion of matter and/or energy, including sensorial organ development. All living beings are able to detect the spatial and temporal dynamics of their environment. More practically, what is required is that living beings be capable of comparing two spatial/temporal instances so as to discern differences as Bateson information, i.e., as *a difference which makes a difference*. Thus, there is no need for declaring information as *a third quantity of the Universe*. Information is a derived property of matter and/or energy. Occam's razor applies to this argument ("Entities should not be multiplied without necessity."). In a sense, Wiener is right, information is "not matter or energy". Fundamentally, information is differences in matter and/or energy detected by living beings. A perspective that brings us back to info-autopoiesis, i.e., information self-production by living beings. In short, all information in nature is created by each and every organism-in-its-environment.

This is what we would like to illustrate and discover using simulations. A comparison between two (or more) spatial/temporal instances, at the most elementary level, can be implemented using a one-parameter feedback loop simulation, consisting of a sensor and a comparator. The comparator to do its job of comparing requires two commensurable inputs: a reference parameter that is set, internally or externally to the system, and a detected parameter supplied by a sensor.

To clarify the distinction between homeostasis (a return to a particular state by self-regulation) in machine mechanisms and homeorhesis (a return to a particular trajectory by self-regulation) in organisms, this section explores, through illustrative examples, the Batesonian *difference which makes a difference* based on the observation that "*The role of feedback both in engineering design and in biology has come to be well established*" (Wiener 1948 1961, vii; Uyanik et al. 2020; Kim and Szurmant 2020). While the role of feedback is well established, a distinction exists between the behaviour of homeostatic, cybernetic mechanisms and homeorhetic organisms, as described below.

To exemplify this approach, we initially examine the one-parameter feedback workings of a device of common usage, a thermostat. Then we turn our attention to a one-parameter feedback simulation of *homeorhetic reflex-actions* in an organism. Homeorhesis indicates system dynamics with different transitions to multi-stable trajectories. Waddington suggested that in biological systems *homeorhesis* (stability of dynamics rather than stability of states) instead of *homeostasis* prevails. In other words, what '*is being held constant is not a single parameter but is a time-extended course of change, that is to say, a trajectory*' (Waddington 1968, 12). Distinctively, a biological system which

follows and returns to a homeorhetic trajectory, as opposed to a system which oscillates around a particular homeostatic state. Next, we look at the process of the two stages of CRISPR-Cas events in a prokaryote as info-autopoiesis at the cellular level.

A One-Parameter Feedback Simulation of a Homeostatic Control Mechanism

Figure 1 shows the relationship between a room and the surrounding environment. The room incorporates an Air Conditioner unit which can cool/heat the room and the associated thermostat control unit that controls its operation. The thermostat control unit consists of a one-parameter *Sensor* and a *Comparator*. The one-parameter *Sensor* measures on a continuous basis the room temperature T that is an input to the *Comparator* as the *detected parameter*. Another input to the *Comparator* is the temperature setting T_o arbitrarily set by the occupant of the room based on her level of comfort and is regarded as the *reference parameter*. The role of the *Comparator* is to obtain the difference $e = T - T_o$ between the *detected parameter* and the *reference parameter*, two commensurable values which are expressed as voltages. This *difference* is classically referred to as *error*. This *difference or error* is the parameter used to trigger the On-Off switch of the Air Conditioner unit. In cooling mode, the Air

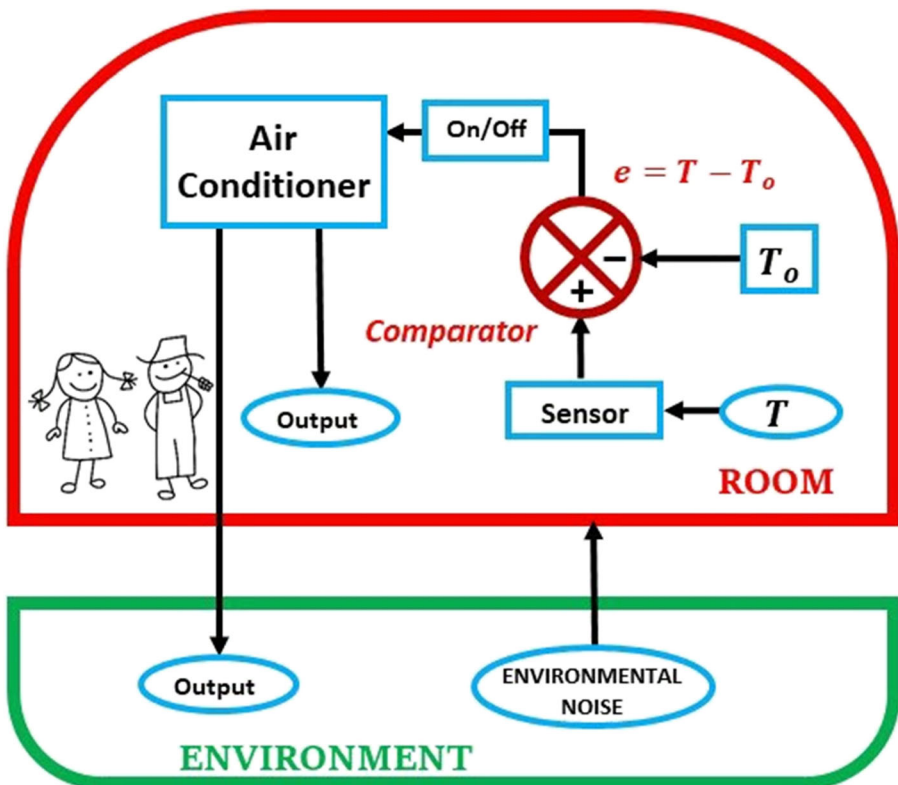

Fig. 1 A one-parameter feedback loop simulation of a homeostatic control mechanism (thermostat) associated with a room air conditioning system

Conditioner turns On when $e > 0$, and turns Off when $e < 0$. The opposite is true when the Air Conditioner is in heating mode. The *Comparator*, the *detected parameter* and the *reference parameter* are the elements at the heart of the Batesonian *difference which makes a difference*. As will be explained below, these components are as relevant to the simulation of a cybernetic homeostatic mechanism, as to that of a homeorhetic organism.

This configuration shows that the actions of the thermostat depend on the *Comparator* as a function of the *difference or error* obtained from comparing the *detected parameter* to the *reference parameter*. The circuit that comprises this system is a semi-closed-loop cybernetic feedback circuit, not a closed-loop cybernetic feedback circuit, such as the biomolecular closed-loop cybernetic homeostatic circuit in Aoki et al. (2019), since there is no direct connection between the Air Conditioner and the *Sensor*. And also, there is no connection between the *Comparator* output and the temperature setting. This brings about the existence of two semi-closed-loop cybernetic feedback circuits. One feedback circuit comprises the Air Conditioner that exhibits two outputs: one to the room, the other to the outside environment. The impact of the Air Conditioner on the *Sensor* is by way of the air currents in the room as well as by way of the environmental noise, which is the impact that the environment might exert on the walls of the room by being more/less windy, hotter/colder than the room. This feedback circuit has an eventual effect on the *detected parameter* of temperature at the one-parameter temperature *Sensor*, leading to a subsequent action affecting the *Comparator* output that leads to an effect on the On/Off switch of the Air Conditioner. A second semi-closed-loop cybernetic feedback circuit mechanism to change the temperature setting T_o is by way of the room occupants. In either of these two cases, the room occupants can intervene to make the room temperature amenable to their needs.

The definition of information by Bateson as *a difference which makes a difference* may be used in the context of this thermostat example. Let us note that this definition of information implies a quantitative portion (*a difference*) and a qualitative portion (*a difference which makes a difference*) (Cárdenas-García and Ireland 2017, 2019). The quantitative portion is the *difference or error* $e = T - T_o$ that is calculated by the *Comparator* that results in the On/Off actuation of the Air Conditioner; the qualitative portion is that given by the comfort level of the person inside the room that controls the setting T_o . Further, the person whose temperature comfort is at issue in the use of the Air Conditioner may have the use of a thermometer to compare its experienced comfort level. This is what drives the temperature setting T_o . Here, we identify, for illustrative reasons that *difference or error*, e , represents Bateson *information*. This means that the terms *difference*, *error or information* are treated as equivalent. We further note that in this homeostatic example the *error* is the term that acts as a cybernetic correction factor in pursuing the goal of temperature T_o .

In short, a four-step conceptualization of this semi-closed-loop cybernetic feedback system, is as follows:

1. A *comparator* (thermostat) is set to a *reference parameter* (room temperature setting);

2. The *sensor* (room temperature sensor) distinguishes the value of the *detected parameter*;
3. The *comparator* obtains the *difference or error* between the *detected parameter* and the *reference parameter*;
4. The detected *difference or error* is the *information* needed to send a signal to turn-on/turn-off the system governing the level of temperature in the room.

This four-step conceptualization for this homeostatic mechanism (thermostat) captures the fundamental nature of the Batesonian *difference which makes a difference*, to more fully quantify/qualify its applicability on a practical basis. This presentation disregards effects such as using an analogue or digital circuit in its implementation, or the effect that timed measurements might have on its dynamics. An additional point to note is that thermostats are a human creation. Therefore, their design, construction and use embody human effort and needs. Further, as will be explained below, their conceptualization, design, construction and use are also reflections of Bateson information and info-autopoiesis.

A One-Parameter Feedback Simulation of Homeorhesis

An organism may be considered, for the most part, as a collection of reflex-actions, i.e., involuntary and nearly instantaneous movements in response to a stimulus. An important assumption here is that reflex-actions are phylogenetic behaviour. For example, a reflex-action such as blinking in humans ontogenically is made possible by neural pathways called reflex arcs which can act on an impulse before that impulse reaches the brain, implying a response to a stimulus that phylogenetically relies on anticipatory-ontogenic derived behaviour. If such reflex-actions did not exist the human organism

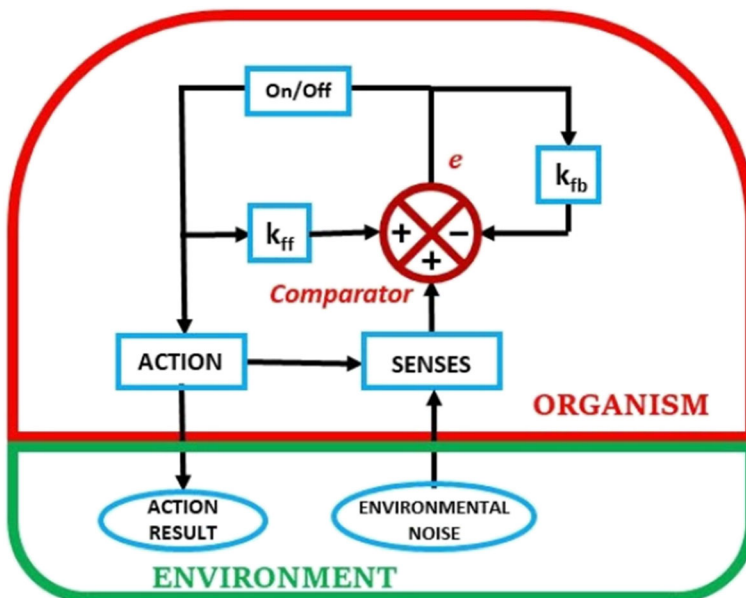

Fig. 2 A one-parameter feedback loop simulation of homeorhesis

would not operate as intended. That is, phylogenetic behaviour can be considered the first layer of homeorhesis.

Figure 2 shows a feedback simulation of the human organism-in-its-environment (HO/E) depicting cyclic self-referenced reflex-action operations to keep homeorhetic trajectories. This figure is drawn with similar elements as that of Fig. 1 to make an eventual comparison as to its functioning. But a significant difference is to draw the two elements that portray the organism (HO) and the environment (E) as comprising a whole. This is done to imply a HO subsumed in its E.

Some elementary actions of organisms are phylogenetic reflex-actions, that generally have something to do with keeping our internal milieu within homeorhetic bounds. It is common that feedback control mechanisms can be ascribed to these phylogenetic reflex-actions, though each type of reflex-action obeys its own non-mechanistic homeorhetic requirements. What we would like to elucidate is how Bateson information, *a difference which makes a difference*, may be used to explain how these homeorhetic processes can occur, although not surrogated, in feedback simulations and compare its functioning to the previously presented one-parameter semi-closed-loop cybernetic feedback homeostatic mechanism.

Referring to Fig. 2, consider the beginning of the HO/E cyclic interactions as the detection of *environmental* noise by the *senses* of the organism. This is the only window that the HO/E has to access the environment. *Environmental noise* is particular to each individual HO/E, since each individual HO/E has a particular set of senses that are attuned to its phylogenetic and ontogenetic development within a specified environment. The primary motivation of the HO/E in sensing the noisy environment that may resemble white noise, particular to the HO/E, is to maintain its individuation and homeorhetic trajectories in epigenetic landscapes due to dynamic openness (Waddington 1968). For example, the HO/E needs to satisfy its energy needs and is tuned to particular cues in the white noise that leads it to satisfy them. This is true of all our *senses* that permit these cues to synchronize to recognize environmental invariance (Cárdenas-García 2013; Cárdenas-García and Ireland 2017, 2019).

The portrayal in Fig. 2 defines the fundamental relationship of the HO/E, as it exists embedded in its environment. There are two essential connections with the environment. One, is shown as a single sense element that is the intermediary between the external environment and the internal milieu of the organism. This single sense element represents a microcosm of reality, since a typical human organism is composed of millions of these sense elements that define each particular sense organ in the human body. The other connection is the capacity of the HO/E to physically impact the environment, either directly or by other means, including tools and machines in the case of humans. It has to be recognized at the outset that these two essential connections define an asymmetrical relationship between the organism and its environment, i.e., the impact that the organism has on the environment is not a mirror reflection of the impact of the environment on the organism. Our intent in what follows is to concentrate on the sensorial side of this dichotomy, as the single sense element is the only means that an HO/E has to ascertain the reality of the external environment to successfully engage it.

The transduction role of the single sense element changes the physical (touch, sound, light) or chemical signature (smell, taste) to a corresponding electrical signal or action potential (AP). It is this AP, irrespective of origin, that is used by the human

organism, either locally or centrally, to generate information, *a difference which makes a difference*. In a similar way, as with the thermostat a *Comparator* is used to show how information is created using this single sensor element to begin the cyclic process of, in this case, self-referenced, autonomous information. In other words, of info-autopoiesis as the autonomous, self-generation of information of the HO/E as a reflection of its structural coupling to the environment.

This process is akin to the *Principle of Undifferentiated Encoding*,

The response of a nerve cell does not encode the physical nature of the agents that caused its response. Encoded is only “how much” at this point on my body, but not “what”. (von Foerster 2003, 4)

Except that the AP that needs to be used, either locally or centrally, is representative of info-autopoiesis or of information that results from the process of info-autopoiesis. As a result, we suggest that the *Principle of Undifferentiated Encoding* may be alternatively defined in terms of *info-autopoiesis*. We argue that because of the specificity of the commensurable sensors, info-autopoiesis does imply something not just about the “how much” but about the “why”, “what”, “when”, and “where” aspects of information. There is greater specificity in its realization due to the integration of information from several differently commensurable sensors to better specify the nature of information for the organism. This is similar to specifying the location of an object in three or more dimensions rather than with a single dimension.

Examining Fig. 2 shows that the *Comparator* has a feedback circuit that incorporates a quantity k_{fb} and a feedforward circuit with quantity k_{ff} to modify the error, e . The feedback signal independently modifies the incoming sensory AP by subtracting a factor $e k_{fb}$, while the feedforward signal independently modifies the same sensory AP by adding a factor $e k_{ff}$, if and when e is able to surmount the trigger level of the On-Off trigger switch. The feedback and feedforward factors, k_{fb} and k_{ff} , respectively, are a function of the needs of the HO/E. We note that the feedback circuit represented in Fig. 2 is neither a closed-loop cybernetic feedback circuit nor a semi-closed-loop cybernetic feedback circuit. The info-autopoiesis circuit is independent of the resulting actions that stem from its instantiation.

An equation that can be obtained from looking at the *Comparator*, where e is the error and AP is the Action Potential, yields

$$e = AP + ek_{ff} - ek_{fb} \quad (1)$$

leading to,

$$e - ek_{ff} + ek_{fb} = AP \quad (2)$$

which after factoring we obtain,

$$e(1 - k_{ff} + k_{fb}) = AP \quad (3)$$

yielding a relationship between input- and output- given by,

$$\frac{e}{AP} = \frac{1}{(1-k_{ff} + k_{fb})} \quad (4)$$

Each of the quantities k_{fb} and k_{ff} may be regarded as functions of *difference, error or information, e*, of time, of historical and other factors particular to the organism under consideration.

The relationship between input- and output- is capable of many fluctuations, allowing this basic first-order feedback system to be capable of accommodating multifaceted behaviour. For example, with this type of approach reflex-actions and actions requiring a longer fuse may be accommodated. Note also that k_{ff} and k_{fb} do not have to exist simultaneously, or may be even triggered by differing phenomena. Also, all settings related to how k_{fb} and k_{ff} come about are internal to the organism, which does not exclude external influences by way of the environment influencing their behaviour, for example, living in times of scarcity of food or water.

For the moment consider only that the comparator has a feedback circuit that incorporates a constant k_{fb} to modify the *difference, error or information, e*, that is generated as the result of the action of the *Comparator* on the incoming sensory AP and the feedback signal $e k_{fb}$, that is we assume $k_{ff}=0$. The case for $k_{ff} \neq 0$ is not further considered here because the intent is to compare the one parameter feedback loop to that of a mechanism. In general, the effect of the $e k_{ff}$ term is to either enhance or conserve e , acting similar to a memory function. We further note that in this homeorhetic example the *error* is not a term that acts as a cybernetic correction factor since we are not dealing with either a closed-loop cybernetic feedback circuit nor with a semi-closed-loop cybernetic feedback circuit. Rather it reflects a self-referenced comparison of the sensor element. It reflects what the homeorhetic organism identifies as information in the environment.

In the left side of composite Fig. 3, we find a plot of the output over the input, i.e., e/AP . In this particular case a constant value of $AP = 1$ is used, and k_{fb} varies from 0.1 to 1.0 in increments of 0.1 resulting in 10 curves generated at 10 time-steps of unspecified length. These curves may be ascribed the role of homeorhetic trajectories. Note that the colour coding in the two images on the right side is used to show how the calculation of e/AP is performed. The curves in the graph show the versatility of the reflex-action depending on the value of k_{fb} . The curve for a value of $k_{fb} = 1.0$ envelops all the other curves as it oscillates between the values of 0 and 1 over time, implying continuous triggering of the reflex-action. All successive curves show an oscillatory reduction over time. For example, the curve for $k_{fb} = 0.1$ after reaching a peak of 1.0 at time interval 1, has a tendency to be stable around a value of 0.9 after time interval 2.

Referring again to Fig. 2 (top right insert, in Fig. 3), note that an On/Off trigger switch is present. This trigger switch will remain On for *difference, error or information, e*, values above a certain *reference value* (not to be confused with the *reference parameter e k_{fb}*), but will remain Off below that same *reference value*. Looking at Fig. 3, if an arbitrary trigger *reference value* is set to a value of $e = 0.85$, the reflex-action will trigger once for all values of k_{fb} , but will trigger four additional times for a value of $k_{fb} = 1.0$; one additional time for a value of $k_{fb} = 0.9$; and, will remain triggered continuously for a value of $k_{fb} = 0.1$. Note that this *reference value* as well as the value

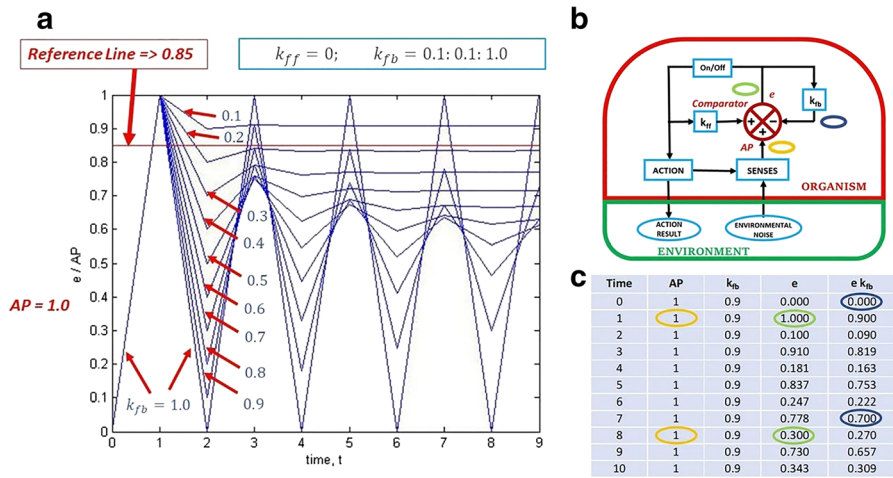

Fig. 3 a The effect of changing k_{fb} in the generation of richer dynamical behaviours. b Color-coded one-parameter feedback loop. c Color-coded variation of one-parameter feedback loop for $k_{fb} = 0.9$

of k_{fb} are fully defined by the organism in question, depending on many factors including those mentioned above.

To summarize, the above description gives the framework of info-autopoiesis as it relates to phylogenetically derived reflex-actions in the context of the definition of Bateson information: *a difference which makes a difference*. This definition of information implies a quantitative portion (a difference) and a qualitative portion (a difference which makes a difference) (Cárdenas-García et al. 2018; Cárdenas-García and Ireland 2017, 2019). The quantitative portion is the difference, error or information $e = AT - ek_{fb}$ that is evaluated by the Comparator that results in, for example, the movement of an organism appendage due to the reflex-action; the qualitative portion is the homeorhetic dynamic of the organism. For example, if the feeling of hunger by an individual recurs, the act of eating restores the homeorhetic dynamic as the organism goes about its business of living.

In short, a four-step conceptualization of how this feedback simulation of the organism consisting of a one-parameter *Sensor* and *Comparator* works, is as follows:

- (1) A *comparator* is set to a *reference parameter*, defined by ek_{fb} ;
- (2) The *sensor* (one of the main senses) distinguishes the value of the *detected parameter*;
- (3) The *comparator* obtains the *difference or error* between the *detected parameter* and the *reference parameter*;
- (4) The detected *difference or error* is the *information* needed to allow the actuation of a reflex-action when it exceeds an organism determined *reference value*.

This four-step conceptualization is different from that of the homeostatic mechanism (thermostat) described above. The described homeorhetic feedback simulation of the organism is capable of the generation of richer and non-predictable, yet self-referential and anticipatory, dynamics.

CRISPR-Cas System as Info-Autopoietic Information in Prokaryote Cells

The CRISPR-Cas system is a two-step approach by prokaryotic cells, such as bacteria and archaea, to achieve, first, an ability to record a memory of infection (Incorporation) and, second, a capability to use that memory of infection as a defence system (Interference) against further infections. CRISPR, which stands for Clustered Regularly Interspaced Short Palindromic Repeats, refers to a family of DNA sequences/spacers incorporated to the genomes of prokaryotic cells using Cas proteins (Barrangou 2015). These sequences/spacers are derived from DNA fragments of bacteriophage and conjugative plasmid origin that have been previously incorporated by the prokaryote cell constituting a memory of past genetic aggressions. Subsequently they are used to confer resistance to foreign genetic elements, by recognizing the DNA of newly invading similar viruses and acting to interfere to eliminate such invaders (Morange 2015a, 2015b).

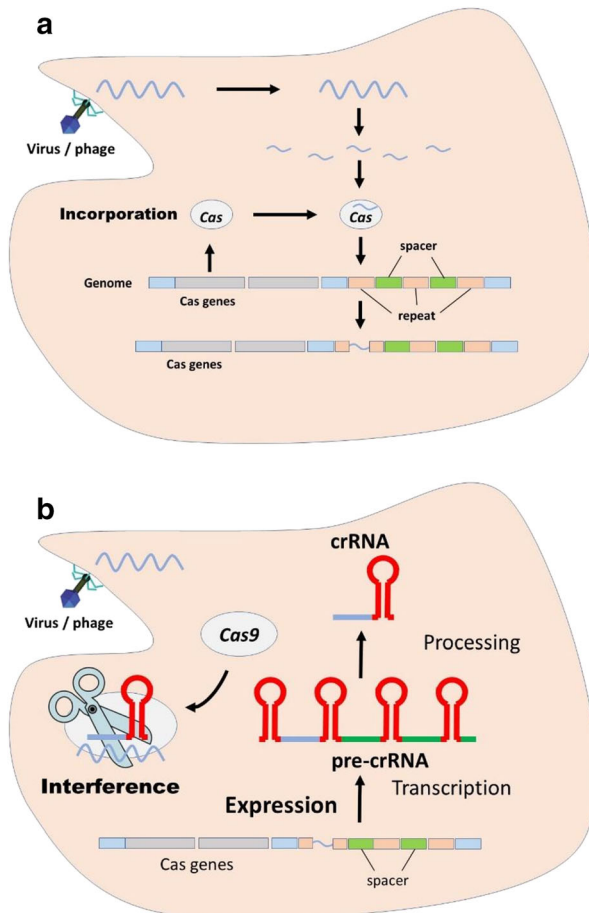

Fig. 4 **a** Stage 1: Incorporation Stage of CRISPR-Cas events in a prokaryote (Adapted from Ishino et al. 2018). **b** Stage 2: Interference Stage of CRISPR-Cas events in a prokaryote (Adapted from Ishino et al. 2018)

In Figs. 4a and b we illustrate stage 1 (Incorporation) and stage 2 (Interference), respectively, the two stages of CRISPR-Cas events in a prokaryote. It is suggested that both stages may be interpreted as info-autopoiesis using a *comparator* to assess the difference between a *reference parameter* and a *detected parameter*.

Stage 1 or the Incorporation Stage of the CRISPR-Cas system initiates when the invading DNA is recognized by Cas proteins, fragmented and incorporated into the spacer region of CRISPR, and made part of the prokaryote genome. While the selected fragments are homologous, there does not appear to be any particular significance to any selected fragment, except its foreign origin that identifies it as not belonging to the invaded prokaryote. By the same token it can be argued that there is no information in the various homologous fragments except for being identified as foreign (Ishino et al. 2018).

Stage 1 or the Incorporation Stage of the CRISPR-Cas system may be summarized as a process of info-autopoiesis as follows:

First stage – CRISPR-Cas acts as a homeorhetic one-parameter feedback loop tuned to an immune response. In other words,

1. The prokaryote in anticipatory mode is capable of detecting viruses/plasmids, in effect it uses a *reference parameter* tuned to viruses and plasmids
2. A prokaryote *sensor* distinguishes the signature of a virus/plasmid or is capable of identifying a *detected parameter* or *signature* of a specific incorporating virus/plasmid and excising a portion of the virus DNA at a specific site
3. The *comparator* obtains the *difference* or *error* between the *detected parameter* and the *reference parameter*
4. The *detected difference* or *error* is the *information* needed to command incorporation of a portion of virus/plasmid DNA into the prokaryote DNA for future reference

Stage 2 or the Interference Stage of the CRISPR-Cas system initiates due to prokaryote anticipatory behaviour resulting from a viral DNA invasion. The initial response is the expression of pre-crRNA by transcription of the CRISPR region and the processing into smaller units of RNA, or crRNA. The homology of the spacer sequence present in crRNA allows the capture and alignment of foreign DNA with homologous segments of the crRNA, proceeding to cleavage of the DNA by the nuclease capability of the Cas protein (Ishino et al. 2018).

Stage 2 or the Interference Stage of the CRISPR-Cas system may also be summarized as a process of info-autopoiesis as follows:

Second stage – CRISPR-Cas acts as a homeorhetic one-parameter feedback loop to eliminate the virus/plasmid

1. The prokaryote in anticipatory mode has several *references of DNA sequences* in its DNA
2. A prokaryote *cell sensor* such as a lipopolysaccharide is used to distinguish the *signature* of a virus/plasmid or identifies a *detected parameter* or *signature* of a specific virus/plasmid

3. The *comparator* obtains the *difference* or *error* between the *detected parameter* and the *reference parameter*
4. The *detected difference* or *error*, in this case the “no difference”, is the *information* needed that results in the transcription of the earlier inserted portion of the virus/plasmid DNA to target and interfere with the DNA of the virus/plasmid

What these interpretations of CRISPR-Cas actions of incorporation and interference reveal is that there is no need for ascription of information to DNA, i.e., there is no need to recognize that a DNA sequence reflects inherent information [see for example Akhter et al. 2013], only that it is a DNA signature of foreign origin. What is implied is that the prokaryote bacteria, in using the CRISPR-Cas actions of incorporation and interference, engages in a process of info-autopoiesis. In the process of incorporation, it identifies specific segments of DNA as corresponding foreign origin to the invading virus DNA and makes it its own while clearly differentiating it from its own DNA. The prokaryote then uses these clearly marked DNA spacers to produce a clear response to a recurring invasion by a similar virus DNA. The ascription of information to DNA occurs in the process of info-autopoiesis: initially in Stage 1 to detect foreign DNA for incorporation of homologous spacers for future reference; and later in Stage 2 to use homologous spacers for comparison to foreign DNA for interference.

The author is not aware of a process by which a prokaryote bacterium would be able to distinguish ‘difference’ or ‘no difference’ between selected homologous fragments of DNA. Clearly this is one of the distinctions between Stage 1 and Stage 2. In Stage 1 “difference” is necessary; in Stage 2 “no difference” is necessary. The adaptability of the prokaryote is certainly noteworthy, depending on circumstance. Human DNA is a quaternary system with four nucleobases [Guanine (G), Adenine (A), Thymine, and Cytosine (C)]. This means that each location can be occupied by any of these four bases. An approach to use Bateson information to determine ‘difference’ or ‘no difference’ might rely on quaternary biomolecular logic gates (Lai et al. 2014). This is beyond the scope of this paper.

Additional Illustrative Examples

In summary, the process of info-autopoiesis is shown to be a process of self-referenced, self-production of information that is common to all living beings. The implication is that information only exists in nature as the result of info-autopoiesis. And, there are no instances in nature where information is found to be independent of a process of info-autopoiesis by living beings. This section further explores the generic nature of info-autopoiesis.

Info-Autopoiesis and Labour

Let us begin with an example that few, even today, would ascribe as related to information: the role of human actions and effort (labour) exerted on our environment. If we look at the etymological origin of the word information, we find that it derives from the Latin stem *informatio*, which comes from the verb *informare* (to inform) in the sense of the action of giving a form to something material as well as the act of communicating knowledge to another person (Capurro and Hjørland 2003; Capurro

2009; Díaz Nafría 2010; Peters 1988). The first of these meanings is what allows us to allude a tie of information to human labour exertion. In other words, the term information may be said to mediate the act of labour between humans and nature, i.e., the act of labour as a metabolic connection between humans and nature is the action of giving form to something material, i.e., labour *in-forms* matter. This can be regarded as self-referenced, self-production of information by the actions of humans on the environment. As a result, matter *in-forms* humans by reacting to the efforts of humans. It is a never-ending recursive and interactive process of sensing-information-action-sensing-information-action, which is directly correlated to Bateson's 'difference which makes a difference' associated to producing changes in our environment. In other words, info-autopoiesis. This is illustrated by Bateson, when describing a labourer yielding an axe:

Consider a tree and a man and an axe. We observe that the axe flies through the air and makes certain sorts of gashes in a pre-existing cut in the side of the tree. If now we want to explain this set of phenomena, we shall be concerned with differences in the cut face of the tree, differences in the retina of the man, differences in his central nervous system, differences in his efferent neural messages, differences in the behavior of his muscles, differences in how the axe flies, to the differences which the axe then makes on the face of the tree. Our explanation (for certain purposes) will go round and round that circuit. In principle, if you want to explain or understand anything in human behavior, you are always dealing with total circuits, completed circuits. This is the elementary cybernetic thought. (Bateson 1978, 458-459)

This is a description that evolves from a cybernetic perspective of the world by Gregory Bateson that identifies differences or information that are pertinent, in this case, to the dynamic and evolving labour effort at hand, which is no different from many typical labour tasks, and can be ascribed as a series of material-informational efforts involving the use of the human brain, nerves, muscles and sense organs (Cárdenas-García et al. 2017; Cárdenas-García et al. 2019). In short, labour and information or differences are intimately entwined and every artefact is the result of info-autopoiesis and embodies information. This aspect of all human artefacts goes largely unnoticed. One result is that we can easily recognize implements manufactured by humans no matter their anthropological age (Aubert et al. 2019); as well as, signs of butchery in animal bones that are more than 2 million years old (Gibbons 2010; Sahnouni et al. 2018).

The effective search for food, the use and creation of tools for hunting and fishing, the domestication of plants and animals, the origination of language and writing are all part of engaging in a process of info-autopoiesis. Other animals also engage with info-autopoiesis: by food selection; nest building by insects and birds; dam building by beavers; the use of pheromones by animals to indicate the presence of food, to signify danger, territory or disposition to mate. This offloading of tasks onto the environment simplifies mental and physical activity. As social organisms, animals developed the capacity to manipulate their environments, build structures in which they embed information enabling them to shape and manage the collective's activities. All of these activities occur because animals interact with their environment in a process

of info-autopoiesis that enhances their abilities for continued interaction. This is true for all living beings, including plants.

Info-Autopoiesis and Shannon Information

The landmark work on the Mathematical Theory of Information by Shannon (1948) and Shannon and Weaver (1949), central to the establishment of ‘Information Theory’ as a discipline, is a most important example to illustrate the potential of info-autopoiesis. Figure 5 shows a block diagram of the elements of the communication system underlying the Mathematical Theory of Communication. The *Information Source* initiates the communication process by the creation of the message to be transmitted. Consider a human being as the *Information Source*. A human being decides, through a process of info-autopoiesis, to say ‘hello’ to someone else. The *Transmitter* may be characterized as the point at which an agreed upon coding takes place such as that implied in language. After which, the message gets transmitted by means of a *Channel* in the form of a *Signal*, which may incorporate a *Noise Source*. This is typical of any signal that is launched into a cable or the airwaves, which accumulates noise from multiple sources in its path, some predictable, some not. The *Receiver* then receives the signal and decodes it, allowing its reception and interpretation at its *Destination*. It may be even argued that this communication system is of a general nature and each and every communication includes all of these steps (Cárdenas-García and Ireland 2019).

One aspect of this communication system is that it can be analysed mathematically in great detail, even incorporating probabilistic prediction in order to recognize the originally sent message out of all possible messages that might have been sent. But there is one aspect that this communication system does not take into account, and that is the semantic content of the message. Shannon was clear about the limitations of his theory and stated that “the semantic aspects of communication are irrelevant to the engineering aspects” (Shannon and Weaver 1949: 8) though in some instances the engineering aspects may reveal or imply semantic content. It is also clear that only a

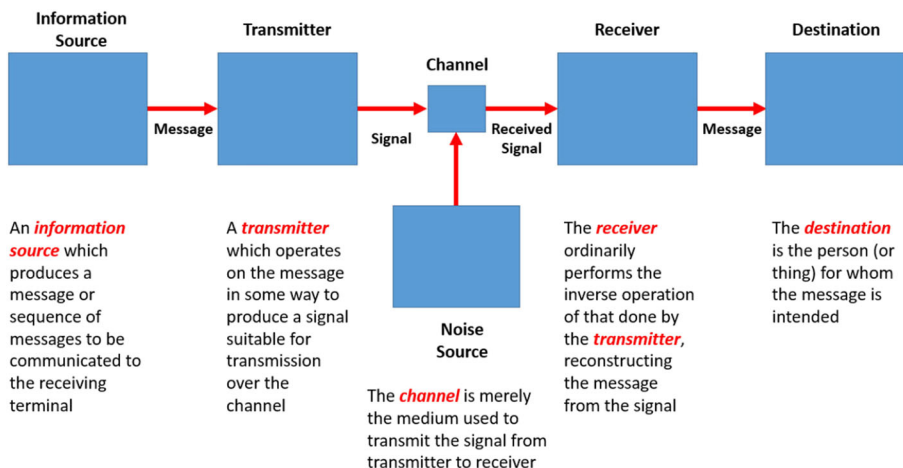

Fig. 5 The communication system (adapted from Shannon 1948)

human being as an *Information Source* and at the *Destination*, create and can make use of, respectively, of this semantic content. This results in confusion as to how exactly the concept of “information” should be used because it is a concept that is content and context dependent. In short, the communication process may be likened to the process of conveying or transmission of messages incorporating information, but it is not the information itself.

In the current epoch, producers and consumers of information are not only humans but also machines that are designed and built for that purpose by humans. The info-autopoietic production and consumption of information by humans consists in being the producers and users of Information and Communication Technologies (ICTs) such as wireless radios, cybernetic control mechanisms, encryption machines, and television, evolving to the technological levels that make items of common usage today such as cell phones, digital televisions, satellite communications, the internet, social media, etc. These ICTs allow messages to be composed by humans/machines, coded, optimally transmitted as communication signals that are received, denoised, decoded and interpreted by humans/machines. This is the basis for the information age. The recognition that the design, construction and use of ICTs involves a process of info-autopoiesis is undeniable.

In the past, we were constrained to use only our primary senses to engage in an info-autopoietic process with nature. It is only recently that we have been able to expand the range of our senses by the artificial creations that we have brought about as a result of our scientific prowess. We have satellites that help us with our weather, we have video cameras, we have infrared sensors, we have ultraviolet sensors, we have x-rays, we have the ability to extend our time frame, we can assess vast expanses of space and time. We can send satellites into outer space that become interstellar travellers. All of these technological marvels act to expand our sensorial capabilities beyond what our five primary senses allow. And we do it through and as a result of our info-autopoietic creativity.

Discussion

The focus of this paper is to propose the process of info-autopoiesis or self-referenced self-production of information by living beings as the source of all information. Key to this process of info-autopoiesis is Bateson’s *difference which makes a difference*, based on a commensurable, self-referential feedback process inherent to the senses of all living beings.

To highlight the general nature of info-autopoiesis, two simulations based on one-parameter feedback were introduced: a homeostatic control mechanism (thermostat) representative of a mechanistic cybernetic system; and, a homeorhetic process inherent to biological systems. Also, the process of active incorporation/interference of viral particles by prokaryotic cells and the activation of CRISPR-Cas was discussed. Table 1 summarizes how one-parameter feedback serves as the common denominator to describe these apparently disparate examples of info-autopoiesis. This serves to illustrate the generic nature of information as *a difference which makes a difference*. The nature of the difference is immaterial just so long as we deal with quantities/qualities that

Table 1 Comparison to discover the versatility of auto-infoipoiesis

Example	Reference Paramater	Detected Paramater	Information Effect
Thermostat	T_0	T	Analog/Digital Trigger of AC
Homeorhetic Model	$e k_{fb}$	Action Potential	Action Potential Trigger
CRISPR-Cas: Step 1	Anticipative DNA segment	Invading Virus DNA segment	DNA Virus Storage
CRISPR-Cas: Step 2	Stored Virus DNA segment	Invading Virus DNA segment	DNA Virus Storage

are commensurable. And this is the nature of our primary senses, they are able to distil the process of comparison to its most fundamental elements.

The main theme in all of these one-parameter feedback loop simulations (homeostatic, homeorhetic and CRISPR-Cas system in prokaryotes) is that of info-autopoietic information. In the homeostatic one-parameter semi-closed-loop cybernetic feedback circuit mechanism, information is obtained using mechanical/electrical signals. One originates in an environmental temperature sensor and the other as a set temperature parameter. Their commensurable comparison results in an *error* that generates a signal to turn the Air Conditioner On/Off. In effect this *error* acts as a cybernetic correction factor in pursuit of set temperature T_0 . The information generated by the thermostat results from a design and its implementation by a human user that thrives on info-autopoietic information. The thermostat is the result of an info-autopoietic creation as it embodies information in its conception, design, manufacture and implementation.

In the theoretical homeorhetic one-parameter feedback loop simulation, information is obtained using an action potential (AP) as a basis for info-autopoiesis. The driving AP originates from selectively filtered environmental noise, which feedbacks into the comparator to make a comparison using a single sensor. Once again it is possible to obtain an *error or difference or information* from commensurable quantities/qualities that effects a specified reflex-action. The role of this *error, difference or information* is not as a cybernetic correction factor, since it has to overcome a specified threshold before instantiation of an action by the organism. It is this info-autopoietic information that leads to a dependent activation/inhibition process.

In the homeorhetic CRISPR-Cas prokaryote a one-parameter feedback loop simulation is identified which uses DNA segments to engage in a process of info-autopoiesis to preserve its living. This suggest that information only exists as info-autopoietic information. Note that the prokaryote cell engages the perturbation using CRISPR-Cas to preserve some motifs of DNA. Even if the cell can do this, it does not mean that it represents information processing or information in Shannon and computational-connectionist terms. Nor does it mean that the info-autopoietic information that it produces has meaning beyond yielding an instantiation for a dependent action. In other words, this does not necessarily mean that the incorporation of viral DNA, which is a non-living particle, denotes information transfer and processing, but rather that the prokaryote enhances its memory domain of a specific virus by uniquely selecting and

adding uniquely selected viral DNA portions to its own genome on which structure-determined anticipative models can be constructed.

The CRISPR-Cas identification of exogenomic material that does not belong to the ontogenetic autopoietic organization of the cell and on which there is not yet an anticipative model, although it could be associative in nature, suggests that viral DNA may be non-sense as far as self-production is concerned. Either, the cell constructs an anticipative model of viral DNA, or the cell produces the virus continuously until its own lysis. Both of these options may correspond to an ecological behaviour.

It is also interesting to consider language and the communication process as an instance of a process of info-autopoiesis similar to that exhibited by the homeorhetic CRISPR-Cas prokaryote. Stage 1 could be construed as the incorporation phase where language gets embedded into the memory of an HO/E through a continuous process of interaction with other individuals. Stage 2 could also be interpreted as an interference stage, where sounds get recognized by a process of interference with the pre-existing embedded memory in the HO/E. While this may be considered a far-fetched suggestion, it does allow for the use of info-autopoiesis as a potential explanatory mechanism.

In all of these instances, *a difference which makes a difference*, a form of producing a dependent activation/inhibition metabolic network, is the underlying framework of a process of info-autopoiesis, or of generating self-referenced information. In general, info-autopoiesis is a relational process that relies on comparing at least two instances of commensurable spatially/temporally quantities/qualities, to achieve self-referenced information. These three examples progress from using commensurable units of mechanical/electrical signals, to action potentials, to DNA segments. The specific nature of the underlying commensurable *difference which makes a difference* is not important, because of its relational nature. The end result is always info-autopoietic information that yields an instantiation of a dependent action. It can be achieved in widely differing situations. What is primary is the process of *a difference which makes a difference*. This may be regarded as the source of activation and inhibition of metabolic networks. Additionally, info-autopoiesis only takes place in biological systems coupled with their environment.

Summary and Conclusions

One of the most vexing aspects of information is the inability to define it to include syntactic/quantitative and semantic/qualitative elements. The definition by Gregory Bateson of information as *a difference which makes a difference* is shown to have this ability (Cárdenas-García and Ireland 2019). Additionally, a sensory commensurable, self-referential feedback process may be shown to be inherent to Bateson's conceptualization of information. Further, the process of info-autopoiesis, or information self-production, is fundamental to the conception of information. In other words, all information does not exist except as a recursive process of info-autopoiesis. The unavoidable implication is that there is no information outside of that generated by living beings through the process of interaction with their environment. In the case of the HO/E the role of labour is fundamental to the in-forming of all human creations.

What is suggested above contradicts the common notions of information in biology, where information is considered to be external to the organism and seems to have a purely objective, standalone existence, able to be processed, stored and transferred. In short, info-autopoiesis is a recursive process that exists in all biological systems and is postulated as the basis to understand information in any biological phenomena: from the single cell, to multi-cellular organisms, to consideration of all types of natural and non-natural phenomena, including tools and artificial constructions.

Acknowledgments The author would like to acknowledge helpful discussions with Sergio dC. Rubin. Additionally, the author would like to acknowledge the reviewers and editors for their helpful, critical and insightful comments and suggestions, which have helped to significantly improve the content of this paper.

Compliance with Ethical Standards

Conflict of Interest The authors declare that they have no conflict of interest.

References

- Akhter, S., Bailey, B. A., Salamon, P., Aziz, R. K., & Edwards, R. A. (2013). Applying Shannon's information theory to bacterial and phage genomes and metagenomes. *Scientific Reports*, 3, 1033–1033. <https://doi.org/10.1038/srep01033>.
- Aoki, S. K., Lillacci, G., Gupta, A., Baumschlager, A., Schweingruber, D., & Khammash, M. (2019). A universal biomolecular integral feedback controller for robust perfect adaptation. *Nature*, 570(7762), 533–537. <https://doi.org/10.1038/s41586-019-1321-1>.
- Aubert, M., Lebe, R., Oktaviana, A. A., Tang, M., Burhan, B., Hamrullah, et al. (2019). Earliest hunting scene in prehistoric art. *Nature*, 576, 442–445. <https://doi.org/10.1038/s41586-019-1806-y>.
- Barbieri, M. (2012). What is Information? [journal article]. *Biosemiotics*, 5(2), 147–152. <https://doi.org/10.1007/s12304-012-9142-8>.
- Barbieri, M. (2013). The paradigms of biology. [journal article]. *Biosemiotics*, 6(1), 33–59. <https://doi.org/10.1007/s12304-012-9149-1>.
- Barrangou, R. (2015). The roles of CRISPR–Cas systems in adaptive immunity and beyond. *Current Opinion in Immunology*, 32, 36–41. <https://doi.org/10.1016/j.coi.2014.12.008>.
- Bateson, G. (1978). *Steps to an ecology of mind; collected essays in anthropology, psychiatry, evolution, and epistemology (Chandler publications for health sciences)*. New York: Ballantine Books.
- Battail, G. (2009). Applying semiotics and Information theory to biology: A critical comparison. [journal article]. *Biosemiotics*, 2(3), 303. <https://doi.org/10.1007/s12304-009-9062-4>.
- Battail, G. (2013). Biology needs Information theory. [journal article]. *Biosemiotics*, 6(1), 77–103. <https://doi.org/10.1007/s12304-012-9152-6>.
- Brier, S. (1999). Biosemiotics and the foundation of cybersemiotics: Reconceptualizing the insights of ethology, second-order cybernetics, and Peirce's semiotics in biosemiotics to create a non-Cartesian information science. *Semiotica*, 127(1–4), 169–198.
- Brier, S. (2008). *Cybersemiotics : why information is not enough!* (Toronto studies in semiotics and communication). Toronto ; Buffalo: University of Toronto Press.
- Burgin, M. (2010). *Theory of Information - Fundamentality, Diversity and Unification* (world scientific series in Information studies – Vol. 1). Singapore: World Scientific Publishing Co. Pte. Ltd.
- Capurro, R. (2009). Past, present, and future of the concept of information. *tripleC*, 7(2), 125–141.
- Capurro, R., & Hjørland, B. (2003). The concept of information. *Annual Review of Information Science and Technology*, 37(1), 343–411. <https://doi.org/10.1002/aris.1440370109>.
- Cárdenas-García, J. F. (2013). Distributed cognition: An ectoderm-centric perspective. [journal article]. *Biosemiotics*, 6(3), 337–350. <https://doi.org/10.1007/s12304-013-9166-8>.
- Cárdenas-García, J. F., & Ireland, T. (2017). Human distributed cognition from an organism-in-its-environment perspective. *Biosemiotics*, 10(2), 265–278. <https://doi.org/10.1007/s12304-017-9293-8>.

- Cárdenas-García, J. F., & Ireland, T. (2019). The fundamental problem of the science of Information. *Biosemiotics*, 12(2), 213–244. <https://doi.org/10.1007/s12304-019-09350-2>.
- Cárdenas-García, J. F., Soria de Mesa, B., & Romero Castro, D. (2017). The Information Process and the Labour Process in the Information Age. *tripleC*, 15(2), 663–685. <https://triple-c.at/index.php/tripleC/article/view/831>.
- Cárdenas-García, J. F., Romero Castro, D., & Soria de Mesa, B. (2018). Object discernment by “a difference which makes a difference”. *Biosemiotics*, 11(1), 27–40. <https://doi.org/10.1007/s12304-018-9315-1>.
- Cárdenas-García, J. F., Soria De Mesa, B., & Romero Castro, D. (2019). Understanding Globalized Digital Labor in the Information Age. *18*(3), 308. <https://doi.org/10.1163/15691497-12341519>.
- Díaz Nafraía, J. M. (2010). What is information? A multidimensional concern. *TripleC*, 8(1), 77–108.
- Floridi, L. (2011). *The philosophy of information*, Oxford. Oxford University Press.
- Fresco, N., Ginsburg, S., & Jablonka, E. (2018). Functional Information: A Graded Taxonomy of Difference Makers. Review of Philosophy and Psychology. <https://doi.org/10.1007/s13164-018-0410-7>.
- Gibbons, A. (2010). Lucy's toolkit? Old bones may show earliest evidence of tool use. *Science*, 329(5993), 738–739. <https://doi.org/10.1126/science.329.5993.738-a>.
- Ishino, Y., Krupovic, M., & Forterre, P. (2018). History of CRISPR-Cas from encounter with a mysterious repeated sequence to genome editing technology. *Journal of Bacteriology*, 200(7), e00580–e00517. <https://doi.org/10.1128/jb.00580-17>.
- Jablonka, E. (2002). Information: Its interpretation, its inheritance, and its sharing. *Philosophy of Science*, 69(4), 578–605. <https://doi.org/10.1086/344621>.
- Kim, I. M., & Szurmant, H. (2020). A bacterial goldilocks mechanism. *Elife*, 9, e54244. <https://doi.org/10.7554/eLife.54244>.
- Lai, Y.-H., Sun, S.-C., & Chuang, M.-C. (2014). Biosensors with built-in biomolecular logic gates for practical applications. *Biosensors*, 4(3), 273–300. <https://doi.org/10.3390/bios4030273>.
- Lloyd, S. (2006). *Programming the universe*. New York: Alfred A. Knopf.
- Maturana, H., & Varela, F. (1973). *De Máquinas y Seres Vivos: Una Teoría de la Organización Biológica*. Santiago de Chile: Editorial Universitaria.
- Maturana, H., & Varela, F. (1980). *Autopoiesis and cognition - the realization of the living*. Dordrecht: D. Reidel Publishing Company.
- Maturana, H., & Varela, F. J. (1987). *The tree of knowledge: The biological roots of human understanding*. Boston: Shambhala Publications, Inc..
- Morange, M. (2015a). What history tells us XXXIX. CRISPR-Cas: From a prokaryotic immune system to a universal genome editing tool. [journal article]. *Journal of Biosciences*, 40(5), 829–832. <https://doi.org/10.1007/s12038-015-9575-8>.
- Morange, M. (2015b). What history tells us XXXVII. CRISPR-Cas: The discovery of an immune system in prokaryotes. [journal article]. *Journal of Biosciences*, 40(2), 221–223. <https://doi.org/10.1007/s12038-015-9532-6>.
- Pattee, H. H. (2013). Epistemic, evolutionary, and physical conditions for biological Information. [journal article]. *Biosemiotics*, 6(1), 9–31. <https://doi.org/10.1007/s12304-012-9150-8>.
- Peters, J. D. (1988). Information: Notes toward a critical history. *Journal of Communication Inquiry*, 12, 9–23.
- Queiroz, J., Emmeche, C., & El-Hani, C. N. (2008). A Peircean approach to ‘Information’ and its relationship with Bateson’s and Jablonka’s ideas. *American Journal of Semiotics*, 24(1–3), 75–94. <https://doi.org/10.5840/ajs200824136>.
- Sahnouni, M., Parés, J. M., Duval, M., Cáceres, I., Harichane, Z., van der Made, J., Pérez-González, A., Abdessadok, S., Kandi, N., Derradji, A., Medig, M., Boulaghrif, K., & Semaw, S. (2018). 1.9-million- and 2.4-million-year-old artifacts and stone tool-cutmarked bones from Ain Boucherit, Algeria. *Science*, 362(6420), 1297–1301. <https://doi.org/10.1126/science.aau0008>.
- Shannon, C. E. (1948). A mathematical theory of communication. *The Bell System Technical Journal*, 27(379–423), 623–656.
- Shannon, C. E., & Weaver, W. (1949). *The mathematical theory of communication*. Urbana: The University of Illinois Press.
- Stonier, T. (1997). *Information and meaning - an evolutionary perspective*. Berlin: Springer-Verlag.
- Umpleby, S. A. (2007). Physical relationships among matter, energy and Information. *Systems Research and Behavioral Science*, 24(3), 369–372.
- Uyanik, I., Sefati, S., Stamper, S. A., Cho, K.-A., Ankarali, M. M., Fortune, E. S., & Cowan, N. J. (2020). Variability in locomotor dynamics reveals the critical role of feedback in task control. *Elife*, 9, e51219. <https://doi.org/10.7554/eLife.51219>.
- Varela, F. J. (1981). Describing the logic of the living. The adequacy and limitations of the idea of Autopoiesis in M. Zeleny (Ed.), *Autopoiesis. A theory of living organization* (pp. 36–48). New York: North Holland.

- Vedral, V. (2010). *Decoding reality - the universe as quantum Information*. Oxford: Oxford University Press.
- von Foerster, H. (2003). *Understanding understanding: Essays on cybernetics and cognition*. New York: Springer-Verlag, Inc.
- Waddington, C. H. (1968). *Towards a theoretical biology; an International Union of Biological Sciences symposium*. Edinburgh: Edinburgh U.P.
- Wheeler, J. A. (1990). Information, Physics, Quantum: The Search for Links in W. H. Zurek (Ed.), *Complexity, Entropy, and the Physics of Information, SFI Studies in the Sciences of Complexity, Reading, MA* (Vol. VIII, pp. 3–28): Addison-Wesley.
- Wiener, N. ([1948] 1961). *Cybernetics: Or control and communication in the animal and the machine, 2nd Edition*. Cambridge: MIT Press.
- Yockey, H. P. (2005). *Information theory, evolution, and the origin of life*. Cambridge: Cambridge University press.

Publisher's Note Springer Nature remains neutral with regard to jurisdictional claims in published maps and institutional affiliations.