

Density-matrix-formalism based scheme for polarization mode dispersion monitoring and compensation in optical fiber communication systems*

DU Qiuping¹, ZHANG Xia^{1**}, GUO Yao¹, YANG Zhenshan^{1**}, and ZHANG Xiaoguang²

1. School of Physics Science and Information Engineering, Shandong Provincial Key Laboratory of Optical Communications Science and Technology, Liaocheng University, Liaocheng 252000, China

2. State Key Laboratory of Information Photonics and Optical Communications, Beijing University of Posts and Telecommunications, Beijing 100876, China

(Received 19 April 2023; Revised 26 June 2023)

©Tianjin University of Technology 2023

We propose a density-matrix-formalism based scheme to study polarization mode dispersion (PMD) monitoring and compensation in optical fiber communication systems. Compared to traditional monitoring and compensation schemes based on the PMD vector in the Stokes space, the scheme we proposed requires no auxiliary matrices and can be handily extended to any higher-dimensional modal space, which is advantageous in mode-division multiplexing (MDM) systems. A 28 GBaud polarization division multiplexing quadrature phase-shift keying (PDM-QPSK) coherent simulation system is built to demonstrate that our scheme can implement the monitoring and compensation of 170 ps large differential-group-delay (*DGD*) that far exceeds the typical *DGDs* in practical optical communication systems. The results verify the effectiveness of the density-matrix-formalism based scheme in PMD monitoring and compensation, thus pave the way for further applications of the scheme in more general MDM optical communication systems.

Document code: A **Article ID:** 1673-1905(2023)12-0739-5

DOI <https://doi.org/10.1007/s11801-023-3074-1>

Polarization division multiplexing (PDM) technology, as one of the most powerful means to enhance the transmission capacity of an optical fiber communication system, is accompanied by a series of polarization effects that might cause impairment to signals transmitted in the system. Polarization mode dispersion (PMD) is a prominent modal effect that causes pulse broadening and distortion^[1-3], thus leading to higher bit error rate (*BER*)^[4,5], or even interruption of transmission in the system. Therefore, it is of great importance to analyze, monitor and compensate the PMD to improve signal transmission quality and system performance.

Traditionally, studies of PMD monitoring and compensation are based on the Stokes formalism^[6-9]. In a single-mode fiber (SMF), there are actually two orthogonal polarization modes. For such a 2-dimensional modal space, the Stokes vector that characterizes the state of an electromagnetic field is a 3-dimensional real vector, which can be represented by a geometrical vector in the Poincare sphere. However, the formulation of Stokes formalism requires 3 auxiliary Pauli matrices that could complicate the analysis of PMD and related modal properties. For mode-division multiplexing (MDM)

technology that employs multiple modes in a fiber to transmit signals (thus further enhancing the transmission capacity), the modal-space dimension N is greater than 2. When the Stokes formalism is extended to study mode dispersion in an N -dimensional ($N > 2$) modal space, it not only loses the intuition advantage as in the PDM system, but also requires $N^2 - 1$ $N \times N$ -dimensional auxiliary Gell-Mann matrices^[10,11]. As N increases, the Stokes formalism gets more complicated and its direct connection to physical information less clear. To address such issues, recently the density-matrix formalism was proposed as an alternative theoretical method to analyze the optical field transmission properties in MDM systems. By adopting the density operator to represent an electromagnetic field state, the density-matrix formalism does not require any auxiliary matrices and can be applied to modal spaces of arbitrary dimension $N \geq 2$ in a unified manner^[12]. Compared to the Stokes formalism, the density-matrix formalism has the evident advantages that its formulation and application are straightforward and physical information can be handily accessed. Even in the PDM ($N=2$) case, as we will show in the current paper, the density-matrix formalism is elegant and can be

* This work has been supported by the National Natural Science Foundation of China (No.61501214), and the Natural Science Foundation of Shandong Province (Nos.ZR2022MF284 and ZR2018MA044).

** E-mails: wenerzhang2002@163.com; yangzhenshan@lcu.edu.cn

employed to study optical-signal monitoring and compensation with a unified scheme.

In view of the above advantages, we propose a PMD monitoring and compensation scheme by use of the density-matrix formalism in this paper. A PMD model featuring the group-delay matrix Ω is constructed, with the independent entries of Ω as the key parameters for the monitoring and compensation. Based on the model, a 28 Gbaud polarization division multiplexing quadrature phase-shift keying (PDM-QPSK) coherent simulation system is built to demonstrate high-accuracy, high-speed and high-efficiency monitoring and compensation for the PMD effects, with the simulation results excellently verifying the effectiveness and feasibility of our density-matrix-formalism based scheme in optical signal monitoring and compensation. The above density-matrix-formalism based scheme can be readily extended to any higher-dimensional modal space (i.e., MDM systems), with a high degree of flexibility and uniformity, thus reducing the complexity of digital signal processing (DSP) in compensation for performance impairments of optical signals. Moreover, the scheme could also be highly suitable for further joint monitoring and compensation of PMD and polarization-dependent loss (PDL), or more generally, for modal dispersion and mode dependent loss in higher-dimensional ($N>2$) mode-division multiplexing systems.

Before introducing the underlying principles of the PMD monitoring and compensation scheme based on the density-matrix formalism, we first give a brief review of the scheme that is based on the Stokes PMD vector τ (see below). Without rotation of state polarization, the evolution matrix can be written as^[13]

$$U_{S-PMD}(\omega) = e^{-i\frac{\omega}{2}\tau\sigma}, \quad (1)$$

where ω is the frequency (relative to a reference frequency ω_0), the PMD vector $\tau=(\tau_1, \tau_2, \tau_3)^T$ is a Stokes vector pointing in the direction of the slow principal state of polarization (PSP) with its length equal to the differential-group-delay (DGD)^[14], and the elements in $\sigma=(\sigma_1, \sigma_2, \sigma_3)^T$ are the auxiliary Pauli matrices. In the PMD monitoring and compensation, the evolution matrix U_{S-PMD} is determined by tracing the parameters τ_1, τ_2, τ_3 . Obviously, the existence of auxiliary Pauli matrices in the exponential function is inconvenient in such numerical algorithms. Although Eq.(1) can be cast into a form in which the auxiliary Pauli do not appear in the exponential function^[15],

$$U_{S-PMD}(\omega) = \mathbf{I} \cos\left(\frac{\omega\Delta\tau}{2}\right) - \frac{j(\tau\cdot\sigma)}{\Delta\tau} \sin\left(\frac{\omega\Delta\tau}{2}\right), \quad (2)$$

with \mathbf{I} being the 2×2 unit matrix, in any higher N -dimensional ($N>2$) modal space (e.g., an MDM system of N modes), there would be a number of (N^2-1) $N\times N$ auxiliary Gell-Mann matrices in the exponential function as in Eq.(1) and a reduction to the form as in Eq.(2) is no longer possible. Moreover, the physical meaning of τ is less clear for $N>2$.

In our proposed scheme, the PMD is directly characterized by the group-delay matrix Ω in the Jones space and the evolution matrix is expressed as

$$U_{DM-PMD}(\omega) = e^{-i\Omega\omega}. \quad (3)$$

Ω is a Hermitian matrix whose eigenvectors and eigenvalues are the PSPs and the corresponding group delays. With the polarization-averaged group delay being removed, Ω is traceless and has 3 independent real variables,

$$\Omega = \begin{bmatrix} \Omega_a & \Omega_b + i\Omega_c \\ \Omega_b - i\Omega_c & -\Omega_a \end{bmatrix}. \quad (4)$$

The three independent variables ($\Omega_a, \Omega_b, \Omega_c$) in Ω are taken as the key parameters in our scheme for PMD monitoring and compensation. We track the key parameters iteratively by using the predicted value at the previous time and the measured value at the current time based on the recursive idea of the extended Kalman filter. Then the evolution matrix U_{DM-PMD} is constructed from Ω according to Eq.(3), and the compensation of PMD is implemented as

$$E_{out}(t) = \text{IFFT}\left[U_{DM-PMD}^{-1}(\omega)\text{FFT}(E_{in}(t))\right], \quad (5)$$

where E_{in} (E_{out}) is the input (output) signal, and FFT (IFFT) represents the fast Fourier (inverse Fourier) transformation.

In our scheme, the advantages of using Ω instead of τ to construct the evolution matrix are that it does not require any auxiliary matrices and the formula of U_{DM-PMD} is identical for any modal-space dimension N . This would allow for the direct generalization of our scheme to treat modal dispersion in mode-division multiplexing systems and greatly simplify the parameter-tracking algorithm for $N>2$. Even in the PMD case ($N=2$), our scheme is more theoretically more elegant with no auxiliary matrices required.

Given the advantages and potentials of our scheme, as the first step in its applications to more general MDM systems, we first employ the scheme to monitor and compensate the PMD impairments on signals in a single mode fiber. We use MATLAB to build a 28 Gbaud PDM-QPSK coherent simulation system that consists of the transmitter, channel, receiver and DSP module, as shown in Fig.1. The transmitter generates and emits the PDM-QPSK optical signals, and the signals are transmitted in the fiber channel and received by the coherent receiver. Next, the DSP is applied for QPSK symbol recovery^[16]. The parameters of the devices are set as follows. For the transmitter, the roll-off factor of the raised cosine filter is 0.1, and the center wavelength of the continuous wave (CW) laser is 1 550 nm. For the channel, the length of fiber is 500 km, and the optical signals experience amplified spontaneous emission (ASE) noise (which would affect the optical signal to noise ratio (OSNR)). In the receiver, the signal is received coherently by a local oscillating laser source with a 1 550 nm central wavelength. In the DSP module, we adopt the scheme proposed above for PMD monitoring and compensation. The effectiveness of our scheme will

be observed in the tracking curves, *BER* with different *DGDs*, and the convergence speed.

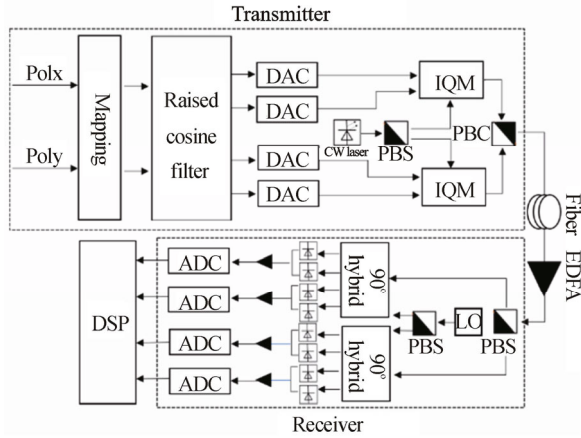

Polx: polarization-x; Poly: polarization-y; DAC: digital-analog converter; CW laser: continuous wave laser; PBS: polarization beam splitter; PBC: polarization beam combiner; IQM: IQ modulator; EDFA: erbium-doped fiber amplifier; LO: local oscillator; ADC: analog-digital converter; DSP: digital signal processing

Fig.1 Overall block diagram of the 28 Gbaud PDM-QPSK coherent system

To verify the accuracy of *DGD* monitoring by use of our scheme, we numerically simulate a PMD system with 80 ps *DGD* under 13.5 dB *OSNR*, and show the results in Figs.2 and 3. Fig.2 plots the tracking curves of the key parameters (Ω_a , Ω_b , Ω_c). Note that, although the values of (Ω_a , Ω_b , Ω_c) do not directly represent physical quantities in the familiar sense, they specifically determine the group-delay matrix Ω , whose eigenvalues in turn give the group delays of the principal states. Fig.3 shows the dynamic tracing curve of the monitored *DGD*, which is calculated from the eigenvalues of Ω . In addition, we can see from the inset of Fig.3 that the tracing curve converges in about 50 iterations, and after that, the estimated *DGD* value (80 ps) essentially coincides with the actual one, thus manifesting excellent convergence performance. With (Ω_a , Ω_b , Ω_c), the evolution matrix $U_{DM-PMD}(\omega)$ is obtained and the signals are recovered using Eqs.(3) and (5), respectively.

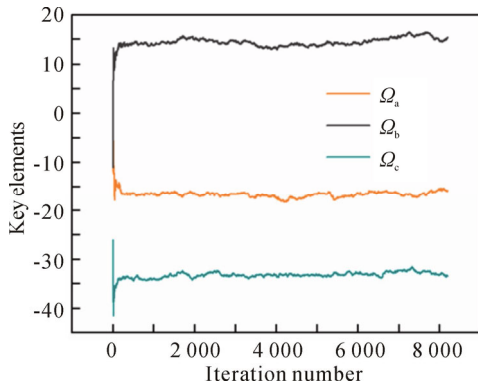

Fig.2 Curves of three key parameters in the tracked state vector at *OSNR* of 13.5 dB and *DGD* of 80 ps

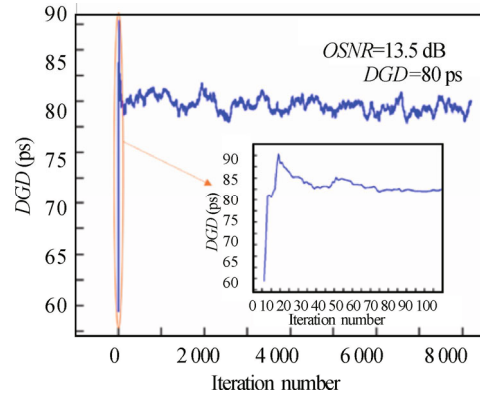

Fig.3 Convergence of iteration for *OSNR* of 13.5 dB and *DGD* of 80 ps

To demonstrate that our scheme can realize compensation of large-scale *DGDs* with a small *OSNR* cost, in Fig.4, we plot *BER* vs. *OSNR* with various *DGDs* from 0 to 160 ps. The results show that with a 7% forward error correction (FEC) threshold ($BER=3.8 \times 10^{-3}$) that can guarantee error-free signal transmission^[17-19], the *OSNR* required for signal transmission is 12.5 dB. When the *DGD* is 40 ps (a typical value of *DGD* in, e.g., a 500-km long optical communication fiber^[20]), our scheme requires just a 0.31 dB *OSNR* penalty (total *OSNR* of 12.81 dB) to complete the compensation of PMD. Furthermore, in the extreme case of large *DGD* of 160 ps, only a 0.84 dB penalty *OSNR* (total *OSNR* of 13.34 dB) is required for the compensation. The inset in Fig.4 gives an example of the constellation diagrams before and after the recovery of QPSK signals at a 14.5 dB *OSNR* with a *DGD* of 40 ps. We see that the constellation points of the recovered signals can be perfectly distinguished, which indicates that the signals are well recovered.

In order to estimate the maximum value of *DGD* that can be monitored and compensated by our scheme, we analyze the *BER* performance under different *DGDs* in a wide range from 20 ps to 180 ps, with the *OSNR* set at 13.5 dB. The results are shown in Fig.5 as the *BER* vs. *DGD* curve. Also, as an example, the constellation diagrams are plotted for the *DGD* of 100 ps. One can see that with the 7% FEC threshold, the tolerance of *DGD* under the 13.5 dB *OSNR* can reach 170 ps, which is larger than the PMD estimation and compensation achieved in Refs.[21] and [22]. This further demonstrates that our density-matrix-formalism based scheme is effective and stable in the monitoring and compensation of large PMD under extreme conditions.

In summary, we proposed a density-matrix-formalism based scheme for PMD monitoring and compensation. The scheme implements the monitoring and compensation of PMD by tracking the key parameters (Ω_a , Ω_b , Ω_c) in the group delay Ω and reconstructing the evolution matrix $U_{DM-PMD}(\omega)$ from Ω . We built a 28 Gbaud PDM-QPSK coherent simulation system to test the effectiveness of our proposed scheme. The small *OSNR* penal

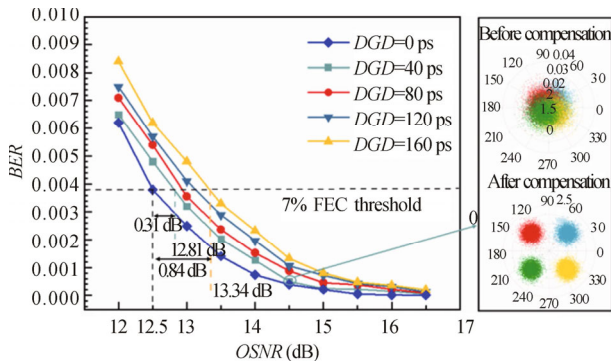

Fig.4 BER vs. OSNR for 28 Gbaud PDM-QPSK signals at various DGDs

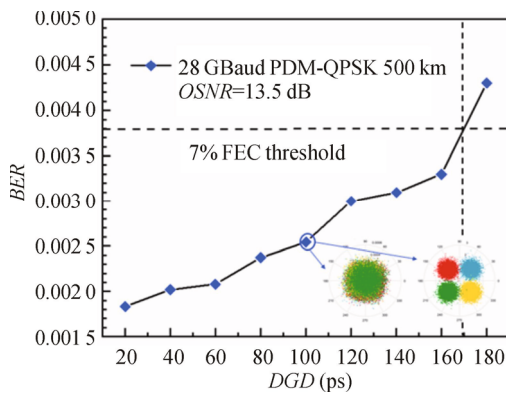

Fig.5 BER vs. DGD for 28 Gbaud PDM-QPSK signals at 13.5 dB OSNR

ties and fast convergence in the monitoring and compensation of *DGDs* over a wide range verify the excellent performance and stability of the scheme. Since the density-matrix-formalism based scheme can be handily extended to higher-dimensional modal spaces to study optical signal monitoring and compensation, our work in the current paper can serve as the first step in the potential applications of our scheme to more general MDM optical communications.

Ethics declarations

Conflicts of interest

The authors declare no conflict of interest.

References

[1] VINAYAGAPRIYA S, SIVASUBRAMANIAN A. Analysis of pulse deformation induced by PDL on propagation of chirped supergaussian pulse in SMF with and without PMD[J]. Journal of theoretical and applied information technology, 2014, 66(1): 104-110.
 [2] VAN DEN BORNE D, HECKER-DENSCHLAG N E, KHOE G D, et al. PMD-induced transmission penalties in polarization-multiplexed transmission[J]. Journal of lightwave technology, 2006, 23(12): 4004-4015.
 [3] BOHATA J, ZVANOVEC S. Impact of PMD changes to optical link performance in a harsh environment[C]//

Latin America Optics and Photonics Conference 2018, November 12-15, 2018, Lima Peru. Washington: Optical Society of America, 2018: Tu4A.30.
 [4] SULIMAN M A, EYADEHI A A, AL-KOFAHII I S, et al. Theoretical and experimental investigation of fiber loss and dispersion effects in optical networks[J]. Journal of electronic devices, 2013, 18: 1524-1530.
 [5] NELSON L E, JOPSON R M, KOGELNIK H. Polarization mode dispersion in optical fibers[C]// Lasers and Electro-Optics Society 2000 Annual Meeting, November 13-16, 2000, Rio Grande, PR, USA. New York: IEEE, 2000, 1: 214-215.
 [6] MUGA N J, PINTO A N. PMD tolerance in Stokes space based polarization de-multiplexing algorithms[J]. Optical and quantum electronics, 2017, 49(6): 1-10.
 [7] ZHANG Q, YANG Y, ZHONG K, et al. Joint polarization tracking and channel equalization based on radius-directed linear Kalman filter[J]. Optics communications, 2018, 407: 142-147.
 [8] ZHENG Z, CUI N, XU H, et al. Window-split structured frequency domain Kalman equalization scheme for large PMD and ultra-fast RSOP in an optical coherent PDM-QPSK system[J]. Optics express, 2018, 26(6): 7211-7226.
 [9] ZHANG Q, CUI N, LI X, et al. Kalman filter polarization demultiplexing algorithm based on diagonalized matrix treatment[J]. Optics express, 2022, 30(2): 2803-2816.
 [10] ANTONELLI C, MECOZZI A, SHTAIF M, et al. Stokes-space analysis of modal dispersion in fibers with multiple mode transmission[J]. Optics express, 2012, 20(11): 11718-11733.
 [11] ROUDAS I, KWAPISZ J. Stokes space representation of modal dispersion[J]. IEEE photonics journal, 2017, 9(5): 1-15.
 [12] YANG Z S, ZHANG X, ZHANG B, et al. Density-matrix formalism for modal coupling and dispersion in mode-division multiplexing communications systems[J]. Optics express, 2020, 28(13): 18658.
 [13] ZHANG X G, TANG X F. Polarization mode dispersion in fibers-principle, measurement, and adaptive compensation[M]. Beijing: Beijing University of Posts and Telecommunications, 2017: 18. (in Chinese)
 [14] POOLE C D, BERGANO N S, WAGNER R E, et al. Polarization dispersion and principal states in a 147-km undersea lightwave cable[J]. Journal of lightwave technology, 2002, 6(7): 1185-1190.
 [15] YI W, ZHENG Z B, CUI N, et al. Joint equalization scheme of ultra-fast RSOP and large PMD compensation in presence of residual chromatic dispersion[J]. Optics express, 2019, 27(15): 21896-21913.
 [16] YU J J, CHI N, CHEN L. Coherent optical communication technology based on digital signal processing[M]. Beijing: People's Posts and Telecommunications Press, 2013: 43-50.

- [17] AGRELL E, SECONDINI M. Information-theoretic tools for optical communications engineers[C]//2018 IEEE Photonics Conference, September 30-October 4, 2018, Reston, VA, USA. New York: IEEE, 2018: 1-5.
- [18] SLEIFFER V A J M, JUNG Y, LEONI P, et al. 30.7 Tb/s (96×320 Gb/s) DP-32QAM transmission over 19-cell photonic band gap fiber[C]//Optical Fiber Communication Conference, March 17-21, 2013, Anaheim, CA, USA. Washington: OSA Technical Digest (online) (Optica Publishing Group), 2013: OW11. 5.
- [19] GNAUCK A H, WINZER P J, CHANDRASEKHAR S, et al. Spectrally efficient long-haul WDM transmission using 224-Gb/s polarization-multiplexed 16-QAM[J]. Journal of lightwave technology, 2011, 29(4): 373-377.
- [20] GORDON J P, KOGELNIK H. PMD fundamentals: polarization mode dispersion in optical fibers[J]. Proceedings of the national academy of sciences, 2000, 97(9): 4541-4550.
- [21] JABEENA A, JAIN A, BASHA N S. Effects of polarization mode dispersion in optical communication system[J]. International journal of control theory and applications, 2016, 9(28): 383-389.
- [22] WANG L, JIANG H X, HE H, et al. PMD estimation and its enabled feedforward adaptive equalization based on superimposed FrFT training sequences[J]. Optics letters, 2021, 46(7): 1526-1529.