

Tunnel visible light communication system utilizing frequency domain pre-equalization technique*

WANG Dong^{1,2**}, LI Chao^{1,2}, and CHE Yue³

1. School of Information Science and Engineering, University of Jinan, Jinan 250022, China

2. Shandong Provincial Key Laboratory of Network-based Intelligent Computing, Jinan 250022, China

3. China Mobile Group Shandong Co., Ltd., Jinan 250101, China

(Received 18 January 2022; Revised 13 April 2022)

©Tianjin University of Technology 2022

Simultaneously improving the communication speed and equalizing the nonlinear frequency response are still challenging for tunnel visible light communication (TVLC) system. Here, we propose and numerically investigate a frequency domain pre-equalization scheme for discrete multitone (DMT) modulation TVLC system. The amplitude of each subscriber is appropriately pre-equalized by optimized nonlinear compensation parameters. Simulation results demonstrate that our proposed equalization technique can resist the channel attenuation of the signal high-frequency part and further flatten the nonlinear channel response. Without forward error correction technique, the bit error ratio (BER) performance can reach 7.66×10^{-6} in a 2.05 Gbit/s DMT-TVLC system.

Document code: A **Article ID:** 1673-1905(2022)08-0484-5

DOI <https://doi.org/10.1007/s11801-022-2006-9>

Tunnel environment is harsh and dangerous. Advanced communication technology is required to improve the efficiency and safety of the tunnel project. Recently, tunnel visible light communication (TVLC) technology with light-emitting diode (LED) has become a hot issue in wireless communication system^[1-3]. Near 400 THz unlicensed frequency band which is almost 13 333 times of the existing wireless communication spectrum can be used for communication. Tunnel communication and illumination can be simultaneously realized without any additional antenna^[4-7].

Two types of white-light LEDs can be used for TVLC system, the phosphor LED (P-LED) which uses blue emitter in conjunction with phosphor, and red-green-blue LED (RGB-LED) which uses separate RGB emitters^[1]. P-LED is more commercialized than RGB-LED because of its easy fabrication. The nonlinear frequency response of LED source acts as serious frequency-selected attenuation. This characteristic can suppress the high-frequency part and further cause inter-symbol interference (ISI). Although the frequency of VLC system can reach 400 THz, the bandwidth of the LED is generally a few megahertz. One efficient solution to realize high-speed tunnel communication is to utilize high-order modulation with RGB-LED. Wavelength division multiplexing technology can be used, in which the information is carried by red, green and blue light separately. Ref.[2] realized 5.6 Gbit/s indoor VLC downlink transmission

(1.5 m) with 4 channel RGB-LED board and discrete multitone (DMT) modulation. We simulated a 4.1 Gbit/s TVLC downlink transmission (1.8 m) with 2 channel RGB-LED board in recent times^[8]. For VLC systems with RGB-LED, the modulation complexity is high. How to control the three chips to maintain color stability and avoid flicker needs to be further studied^[8-10]. Therefore, in order to commercialize VLC technology as soon as possible, many researchers begin to study VLC system based on P-LED.

There are few examples to realize beyond 1 Gbit/s VLC transmission communication with P-LED^[3,11-18]. Ref.[7] reported a 1 Gbit/s indoor VLC link with P-LED and DMT modulation. The maximum transmission distance was 10 cm. Typical distances between the source and the receiver should be greater than 1 m. Ref.[11] reported a 700.68 Mbit/s VLC system based on P-LED. Orthogonal frequency division multiplexing (OFDM) modulation and Volterra filtering equalization were used in the system. Ref.[13] reported a 403 Mbit/s VLC system. Different LED chips in an LED lamp were driven by different bands of OFDM signals. This could avoid the power fading and nonlinearity issue. The transmission rate needs to be further improved. The efficient way to accomplish high-speed long-distance communication within such restricted bandwidth of P-LED is using equalization technology in the DMT-TVLC system.

In our paper, a novel frequency domain

* This work has been supported by the National Natural Science Foundation of China (No.61905091), and the PhD Foundation of University of Jinan (No.XBS1901).

** E-mail: ise_wangdong@ujn.edu.cn

pre-equalization technique in the DMT-TVLC system is proposed and numerically studied.

The block diagram of DMT-TVLC system is depicted in Fig.1. Firstly, the 2.05 Gbit/s binary data is modulated into 16 quadrature amplitude modulation (16QAM) format. To suppress the nonlinear frequency response of the VLC channel, the proposed pre-equalizer technique is used to compensate for the distortion of the signals. Then, inverse fast Fourier transform (IFFT) converts those complex input into real-valued DMT signals with Hermitian mapping. The real-valued signals are sent to digital-to-analog converter (DAC) and amplified by an electronic amplifier. Finally, the amplified signals are sent to drive the P-LED. The downlink demodulation can be realized by a TVLC receiver which consisted of a PIN diode, electrical amplifier and DMT receiver.

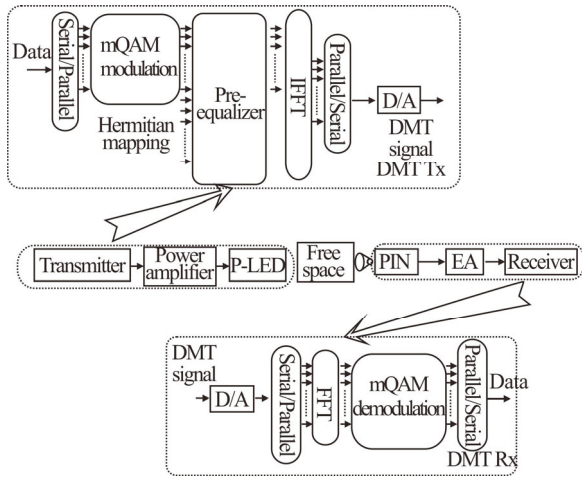

Fig.1 Block diagram of the DMT TVLC system

The optical signal power is a function of the input signal. The conversion of the input signal into optical power is calculated as follows^[5]

$$P_t = \eta hf \frac{i(t)}{q}, \quad (1)$$

where h is the Planck's constant, η is the quantum efficiency, f is the emission frequency, q is the electron charge, and $i(t)$ is the input signal^[5].

The frequency response of the optical wireless channel is given by

$$H(\omega) = \exp\left(-\frac{\omega}{\omega_b}\right), \quad (2)$$

where $\omega_b = 2\pi \times 16 \times 10^6$ is the matching coefficient for the wireless channel^[5-7]. The nonlinear frequency response of VLC channel acts as serious frequency-selected attenuation. This characteristic can highly suppress the high-frequency part.

Fig.2 illustrates the propagation model of sight and diffused link in a TVLC channel. The loss of tunnel optical path is difficult to predict because it is affected by many factors, such as tunnel dimensions and the reflectivity of the physical matters within the tunnel^[7]. In this

paper, the influence of reflected signal on receiving power is fully considered. A P-LED is installed on the ceiling of the tunnel. The receiver is installed on the top of an engineering vehicle. In our propagation model, D is the distance between the receiver and transmitter. D_1 is the distance between the P-LED and a reflective point. D_2 is the distance between the reflective point and the receiver. The received power is generally defined as

$$P_{re} = [H_{los}(0) + H_{nlos}(0)]P_t, \quad (3)$$

where $H_{nlos}(0)$ represents the direct-current (DC) gain of the reflected path, and $H_{los}(0)$ represents the DC gain of the sight path.

$$H_{los}(0) = \frac{A(m+1)}{2\pi D^2} \cos^m(\phi) g(\psi) \cos(\psi), \quad (4)$$

$$H_{nlos}(0) = \frac{A(m+1)}{2\pi D_1^2 D_2^2} \rho A_{ref} \cos^m(\phi) \cos(\alpha) \cos(\beta) \times g(\psi) \cos(\psi), \quad (5)$$

where $A=1 \text{ cm}^2$ is the physical area of the photodiode. $\psi=60^\circ$ is the angle of incidence. $\phi=70^\circ$ is the angle of irradiance. $\rho=0.7$ is the reflectance factor. $\alpha=20^\circ$ is the angle of irradiance to a reflective point. $\beta=30^\circ$ is the angle of irradiance to the receiver. A_{ref} is the reflective area of a small region. $g(\psi)=1.5$ is the gain of an optical concentrator. m is the Lambert's mode number expressing directivity of the source beam. m is related to the LED semi-angle at half-power $\phi_{1/2}=60^\circ$ by

$$m = \frac{-\ln 2}{\ln(\cos \phi_{1/2})}. \quad (6)$$

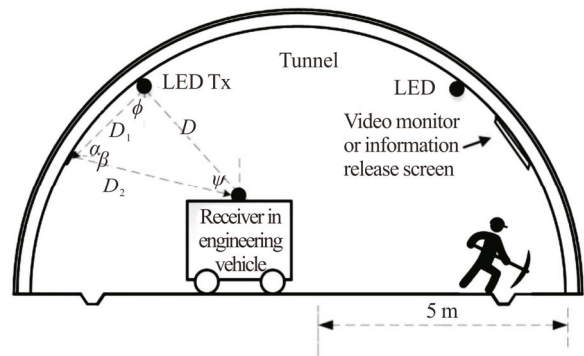

Fig.2 Propagation model of sight and diffused link in the TVLC system

To realize high-speed communication, DMT modulation is carried in this paper. According to the characteristics of DMT modulation, we can estimate the frequency response of any subcarrier. In this way, the gain of the high-frequency part can be increased by frequency domain pre-equalization to flatten the channel response.

As illustrated in Fig.3, the 16QAM modulation data $X=(x_1, x_2, \dots, x_{N/2})$ is loaded on the front $N/2$ subcarriers of DMT signals. The pre-equalization is carried before IFFT processing. The loaded data X of each subscriber is appropriately pre-equalized by the calculated nonlinear

compensation parameter $R=(r_1, r_2, \dots, r_{N/2})$. The equalizer response is set as^[7, 8]

$$R(r_1, r_2, \dots, r_{N/2}) = \frac{1}{H(\omega_1, \omega_2, \dots, \omega_{N/2})}. \quad (7)$$

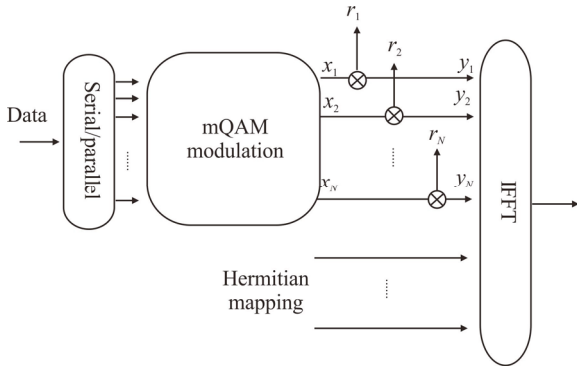

Fig.3 Principle of the proposed frequency domain pre-equalization technique

Then the loaded data of each frequency Y can be addressed as

$$\begin{pmatrix} y_1 \\ y_2 \\ \vdots \\ y_{N/2} \end{pmatrix} = \begin{pmatrix} x_1 & 0 & \dots & 0 \\ 0 & x_2 & \dots & 0 \\ \vdots & \vdots & \dots & \vdots \\ 0 & 0 & \dots & x_{N/2} \end{pmatrix} \begin{pmatrix} r_1 \\ r_2 \\ \vdots \\ r_{N/2} \end{pmatrix}, \quad (8)$$

$$Y = (x_1 r_1, x_2 r_2, \dots, x_{N/2} r_{N/2}). \quad (9)$$

The P-LED typically employs blue emitter in conjunction with yellow phosphor. In the blue light zone, there is an illumination peak. The yellow phosphor is emitted by the blue light. Then, in the green and red light regions, other illumination peaks can be obtained. The blue emitter has a faster frequency response than the yellow phosphor. Because of the slow response of the phosphors, the effective bandwidth of the P-LED around 20 dB point is nearly a few megahertz. A blue filter can be utilized to suppress the slow phosphorescent components.

The received optical power in optical wireless link is simulated. Fig.4 shows the 3D power distribution of the received light signal. The luminous flux of the P-LED is about 16—20 dBm in our simulation. As is shown in Fig.4, the receiving point which is closest to the light source gets the highest received signal power due to the minimum attenuation. The received power decreases as the radiant angle deviates.

According to the VLC channel model, the pre-equalization scheme has been designed and applied. The electrical spectra of the received signals with and without equalization are shown in Fig.5. The nonlinear frequency response of the VLC channel acts as frequency-selected attenuation. Fig.5(a) shows that the high-frequency parts of the signals are highly suppressed. As illustrated from Fig.5(b), the amplitudes of all subcarriers are appropriately pre-equalized. The spec-

tra of the signals with pre-equalization are much more flattened.

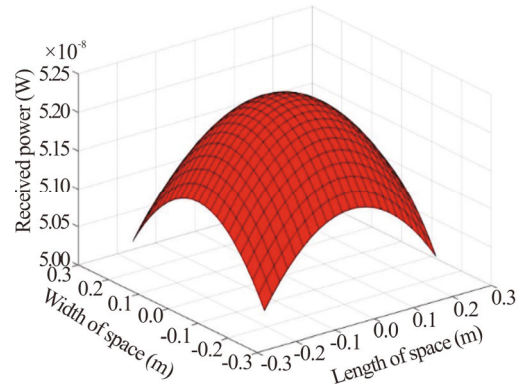

Fig.4 Distribution of the received power

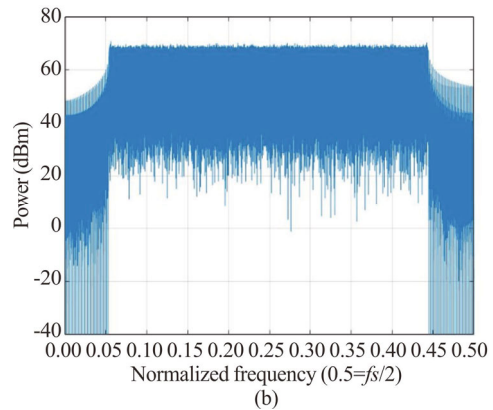
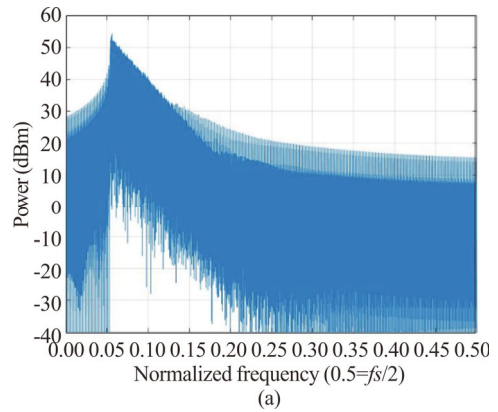

Fig.5 (a) Electrical spectrum of DMT signal without pre-equalization; (b) Electrical spectrum of DMT signal with pre-equalization

Fig.6(a) shows the received constellation diagram without pre-equalization. As a result of the suppression of the high-frequency part, the received constellation diagram is fuzzy. It is difficult to distinguish constellations from each other. The bit error ratio (BER) performance is over 50%. On the other hand, the proposed frequency-domain pre-equalization scheme can resist the nonlinear channel attenuation of the high-frequency part. The gain of the received signal spectrum becomes flat.

As we can see from Fig.6(b), the received constellations with the proposed algorithm converge well to the standard point. It is easy to be distinguished. The *BER* can get to 7.66×10^{-6} . When the communication rate is higher than 2.05 Gbit/s, the higher-order modulation technique is needed to make the LED work in the linear region. However, higher-order modulation has lower ability to resist noise. The higher the communication rate, the worse the effect of the proposed algorithm will be.

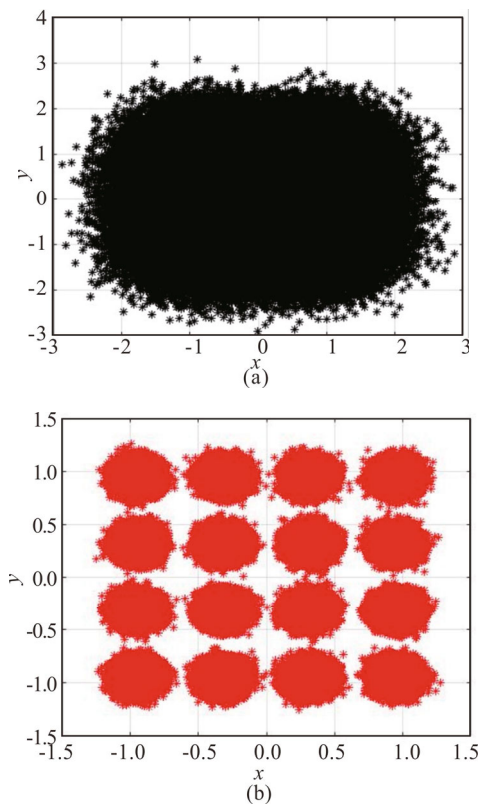

Fig.6 (a) Received constellation diagram without pre-equalization; (b) Received constellation diagram with pre-equalization

Fig.7 illustrates the *BER* performance with the proposed frequency-domain pre-equalization technique. The *BER* degrades as the transmission distance increases. At 1.7 m transmission distance, the *BER* can get to 7.66×10^{-6} when the input power of the P-LED is 20 dBm. The constellations converge well to the standard point. When the transmission distance exceeds 2 m, the *BER* degrades rapidly. When the input power of the P-LED is 18 dBm, the *BER* can reach 5.74×10^{-6} at 1.3 m transmission distance. With the decrease of the input power, the transmission distance of the DMT-TVLC gradually reduced. In brief, the DMT-TVLC system with good *BER* performance can be realized by the proposed frequency-domain pre-equalization technique.

Fig.8 illustrates the comparison of *BER* performance between TVLC systems with P-LED and RGB-LED. The *BER* performance gets deteriorated when the transmission distance increases. The *BER* performance of

TVLC system with red-chip LED is better than that with the P-LED. The brief reason is that the effective bandwidth around 20 dB point of the P-LED is narrower than that of the RGB-LED. The frequency responses of blue and red chips of RGB-LED are almost the same. And the frequency response of green-chip is better than that of P-LED. Similar *BER* performance can be obtained in TVLC system with P-LED and green-chip RGB-LED. The advantages of P-LED are simple implementation and low cost. On the contrary, the modulation complexity of RGB-LED is high. How to control the three chips to maintain color stability and avoid flicker remains to be further studied. The TVLC system with P-LED may be the most effective solution before commercialization.

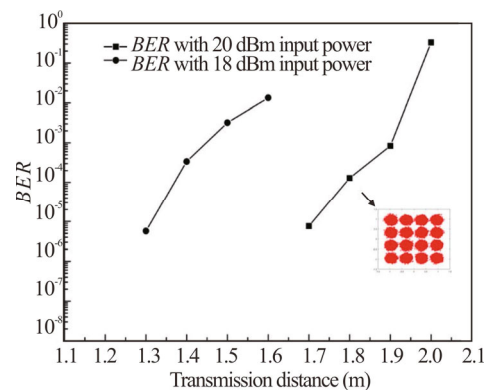

Fig.7 BER versus transmission distance

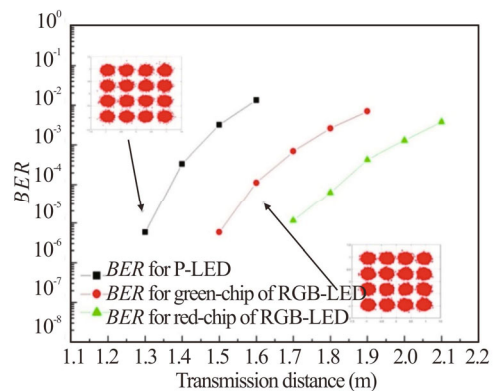

Fig.8 Comparison of BER performance between P-LED and RGB-LED

Frequency domain pre-equalization is an effective approach to compensate for the nonlinear frequency response of the DMT TVLC system. In this paper, a novel frequency domain pre-equalization technique is presented. The amplitude of each subscriber is appropriately pre-equalized by optimized nonlinear compensation parameters. Simulation results demonstrate that the proposed equalization technique is a promising nonlinear compensation method for TVLC system. Without forward error correction technique, the *BER* performance can reach 7.66×10^{-6} . It is believed that the proposed pre-equalization technique will play an important role in

the next generation TVLC systems.

Statements and Declarations

The authors declare that there are no conflicts of interest related to this article.

References

- [1] BRIEND O, MINHH L, ZENG L, et al. Indoor visible light communications: challenges and prospects[J]. SPIE, 2008, 7091: 709106-1-9.
- [2] COSSU G, WAJAHAT A, CORSINI R, et al. 5.6Gbit/s downlink and 1.5Gbit/s uplink optical wireless transmission at indoor distances (>1.5m)[C]//2014 The European Conference on Optical Communication (ECOC), September 21-25, 2014, Cannes, France. New York: IEEE, 2014: 14768268.
- [3] KHALIDA M, COSSU G, CORSINI R, et al. 1Gb/s transmission over a phosphorescent white LED by using rate-adaptive discrete multitone modulation[J]. IEEE photonics journal, 2012, 4: 1465-1473.
- [4] WANG Y, TAO L, HUANG X, et al. Enhanced performance of high-speed WDM CAP64 VLC system employing Volterra series-based nonlinear equalizer[J]. IEEE photonics journal, 2015, 7: 1-8.
- [5] GHASSEMLOOY Z, POPOOLA W, RAJBHANDARI S. Optical wireless communication system and channel modeling with Matlab[M]. Boca Raton: CRC Press, 2013: 81-83.
- [6] WANG Y, WANG Y, CHI N, et al. Demonstration of 575 Mb/s downlink and 225Mb/s uplink bi-directional SCM-WDM visible light communication using RGB LED and phosphor-based LED[J]. Optics express, 2013, 21: 1203-1208.
- [7] ZENG L, BRIEN D, LE-MINH H, et al. Improvement of data rate by using equalization in an indoor visible light communication system[C]//Proceedings of 2008 4th IEEE International Conference on Circuits & Systems for Communications, May 26-28, 2008, Shanghai, China. New York: IEEE, 2008: 678-682.
- [8] WANG D, LI C, WANG Y H, et al. Tunnel visible light communication system utilizing nonlinear suppression technique[J]. Optik, 2021, 228: 166195.
- [9] ZHOU Z, LIU L, WANG G. 2.03 Gbps visible light communication system with 64-QAM-OFDM utilizing a single flip-chip blue GaN-LED[J]. Journal of modern optics, 2019, 66: 2114-2118.
- [10] CHOU H H, LIAW S K, JIANG J S, et al. Experimental study of red-, green-, and blue-based light emitting diodes visible light communications for micro-projector application[J]. Fiber and integrated optics, 2016, 35: 98-113.
- [11] HSU C, CHEN G, WEI L. Adaptive filtering for white-light LED visible light communication[J]. Optical engineering, 2017, 56: 016115-1-5.
- [12] CHOW C, YEH C, LIU Y. Improved modulation speed of LED visible light communication system integrated to main electricity network[J]. Electronics letters, 2011, 47: 867-1-2.
- [13] YEH C, CHEN H, CHOW C, et al. Utilization of multi-band OFDM modulation to increase traffic rate of phosphor-LED wireless VLC[J]. Optics express, 2015, 23: 1133-11138.
- [14] RANGEET M, SANDESH J, VIMAL B. Least minimum symbol error rate based post-distortion for VLC using random Fourier features[J]. IEEE communications letters, 2020, 24: 830-834.
- [15] MITRA R, JAIN S, BHATIA V. Kernel MSER-DFE based post-distorter for VLC using random Fourier features[J]. IEEE transactions on vehicular technology, 2020, 69(12): 16241-16246.
- [16] MITRA R, JAIN S, BHATIA V. On BER analysis of nonlinear VLC systems under ambient light and imperfect/outdated CSI[J]. OSA continuum, 2020, 3: 3125-3140.
- [17] WANG J L, CHEN N, ZHANG S R, et al. Sparse kernel affine projection-based nonlinear distortion compensation and memory effect depression algorithm in VLC systems[J]. Photonics journal IEEE, 2022, 14: 1-6.
- [18] FARSHAD M, MEHDI K, ENGIN Z, et al. Enabling 5G indoor services for residential environment using VLC technology[J]. Physical communication, 2022, 53: 101679.