

A 10 Gbit/s OCDMA system based on electric encoding and optical transmission*

LI Chuan-qi (李传起)***, HU Jin-lin (胡金林), HE Dong-dong (贺冬冬), CHEN Mei-juan (陈美娟), WANG Da-chi (王大迟), and CHEN Yan (陈艳)

Electronic Engineering College, Guangxi Normal University, Guilin 541004, China

(Received 9 July 2013)

©Tianjin University of Technology and Springer-Verlag Berlin Heidelberg 2013

An electric encoded/optical transmission system of code division multiple access (CDMA) is proposed. It encodes the user signal in electric domain, and transfers the different code slice signals via the different wavelengths of light. This electric domain encoder/decoder is compared with current traditional encoder/decoder. Four-user modulation/demodulation optical CDMA (OCDMA) system with rate of 2.5 Gbit/s is simulated, which is based on the optical orthogonal code (OCC) designed in our laboratory. The results show that the structure of electric encoding/optical transmission can encode/decode signal correctly, and can achieve the chip rate equal to the user data rate. It can overcome the rate limitation of electronic bottleneck, and bring some potential applications in the electro-optical OCDMA system.

Document code: A **Article ID:** 1673-1905(2013)06-0473-4

DOI 10.1007/s11801-013-3125-0

Optical code division multiple access (OCDMA) is a new combined technology of optical communication and electric CDMA technology. OCDMA is a good choice for broadband networks and LAN in the future^[1,2].

With the development of fiber Bragg grating (FBG) and some optical devices^[3,4], the OCDMA attracts much attention, but study on the practical methods is slow. The codec is designed by optical devices^[1,2,5,6], which results in bad flexibility, and the beat noise and multi-site interference based on the traditional codec technology are serious problems^[7-9]. Due to the faster processing speed in electric domain, a new technique which applies CDMA to electric domain and communicates via optical fiber begins to get attention^[10,11]. In 2009, J. B. Rosas Fernandez^[10] designed an electric CDMA (ECDMA) codec by Fourier infrared (FIR) transversal filters to make ECDMA communication experiment with transmission speed of 1.25 Gbit/s. In 2010, Yasuhiro Kotani et al^[11] proposed an electrical domain processing code division multiplexing (ECDM) passive optical network (PON) system structure, and achieved eight-user 1.25-Gchip/s downstream transmission system experiment using a code length of 8 Walsh codes. But the limitation of electronic bottleneck leads to a series of problems. On account of above situations, researchers have developed a plan of spatial encoding. Because of high-speed optical switch array and laser array, it is a huge challenge for cost^[12,13].

A method for encoding signals in electric domain is proposed in this paper. It applies amplified spontaneous emission (ASE) broadband source, fiber Bragg gratings (FBGs), programmable logic devices and optical orthogonal code (OOC) designed by our research group in simulation^[14], and proves the performance of the four-user 2.5 Gbit/s system.

Electric codec solves the system's beat noise and multiple access interference (MAI) noise, but electronic bottleneck limits its application in OCDMA. This paper designs a scheme in spectral domain with encoding signals based on multi-step amplitude in electric domain. Fig.1 shows the structure of transmitting terminal. The user's address code is $(L, \omega, 1)$, where L is address code length, ω is code weight and 1 represents correlation coefficient. N uncoded user signals are converted to L coded signal chips via electric encoder, and the chips enter the optical coupler through L optical intensity modulators (IMs). In transmitting terminal, ASE broadband light source transforms into L single-wavelength light sources by FBGs, and encoded signals modulate light sources in optical IM. Optical encoded signal 1, optical encoded signal 2, ..., and optical encoded signal L are generated.

Fig.2 displays the theory of electric encoding in four users. At transmitting terminal of encoder, binary data from user R_j ($1 \leq j \leq N$) are assigned to the L parallel multipliers via power divider, and then are multiplied by ad-

* This work has been supported by the University Nature Science Fund of Guangxi Province (No.20101MS018), and Guilin Scientific Research and Technological Development Program Topics (No.20120104-18).

** E-mail: lcq@gxnu.edu.cn

dress code chips of user R_j , so we can get encoded chip 1, encoded chip 2, ..., and encoded chip L . The k th encoded chip ($1 \leq k \leq L$) from every user is assigned to the k th adding device to get encoded signal. If binary data are represented as $D_n(t)$, the output encoded signals can be calculated as

$$D'_k(t) = \sum_{n=1}^N D_n(t) C_{n,k}, \quad (1)$$

where $D_n(t)$ is user's signal, $C_{n,k}$ is the k th multiplier corresponding to the n th user's encoder ($k=1, 2, \dots, L$), and N is the number of total users.

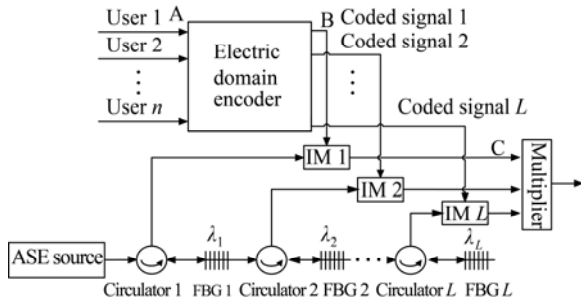

Fig.1 Schematic diagram of OCDMA transmission system based on electric domain

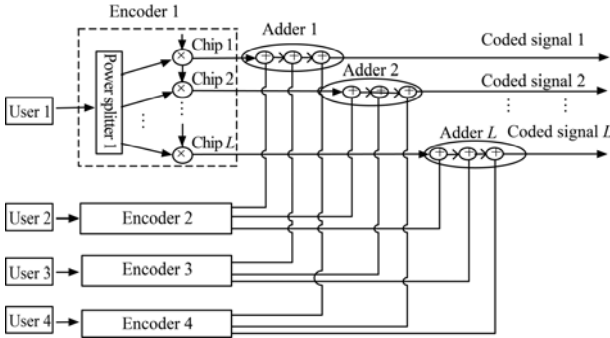

Fig.2 Electric encoding of four-user system

In receiving terminal, the electrical domain decoder is the core component of the system. The plan decodes signals by the theory of balanced detection. Firstly, the compound signals decompose into the optical signals with wavelengths of $\lambda_1, \lambda_2, \dots, \lambda_L$ through optical wavelength division multiplexer (WDM). Then photoelectric detector translates the optical signals into L electrical signals, which can be decoded by related user's address code.

The user's address code $X_j=(x_1, x_2, \dots, x_L)_j$ controls the output of L electrical signals to regain data of user R_j . At first, the k th electrical power signal ($1 \leq k \leq L$) is divided into two parts, the first part is multiplied with the k th user address code to get branch signal $k.1$, and the second part is multiplied with the k th user address code's complement \bar{x}_k ($\bar{x}_k=1-x_k$) and attenuation coefficient α to get branch signal $k.2$. According to the principle of balance detection, in order to eliminate interference from other users, take $\alpha=\lambda/(\omega-\lambda)$, and signal $k.1$ takes away signal $k.2$, leaving the k th decoded chip signal.

The L decoded chips add to each other in multipliers, and we can get the decoded chip power of user R_j , so the signal of user R_j can be regained from weighted multiplier. If the power of electrical signal is RX_k , the decoded signal of user R_j can be considered as

$$P_j = \frac{1}{W} \left(\sum_{k=1}^L RX_k \cdot x_k - \alpha \sum_{k=1}^L RX_k \cdot \bar{x}_k \right), \quad x_k \in X_j. \quad (2)$$

The user's address code in this paper is OCC with excellent performance, and it is designed by our team. The user's address code is characterized by the following parameters (L, ω, λ) , where L is the length of the code, ω is the weight of the code, and λ is the auto-correlation constraint.

Fig.3 shows the structure of experimental system. The ASE broadband source and a cascade of FBGs generate L single-wavelength light source pulses, and then the encoded signals modulate the light source pulses to produce optical encoded signals. The power of light pulse is 0 dBm. The modulated light signals are merged by optical coupler, amplified in erbium-doped fiber amplifier (EDFA), and transferred by optical fiber. We can separate the light encoded signals from WDM, and regain the encoded signals from optoelectronic detector. Then the encoded signals are decoded by electric decoder, and in the end the user's signal is regained from weighted multiplier.

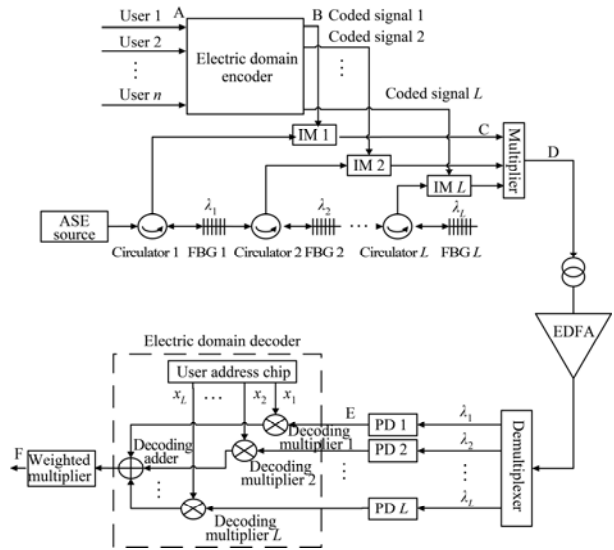

Fig.3 Schematic diagram of the experimental system

This experiment simulates a four-user system, whose address code is OOC of $(13,4,1,1)$ designed by our research group, and the data streams are $(1,0,1,1,0,0,1)$, $(1,1,0,1,0,1,0)$, $(1,1,1,0,1,0,0)$ and $(0,1,0,0,1,0,1)$ with data rate of 2.5 Gbit/s, respectively. The four users' address codes are $(1,2,4,10)$, $(3,4,6,12)$, $(1,5,6,8)$ and $(2,6,7,9)$, respectively.

At the sender, single-wavelength light sources are modulated by the 13 encoded signals in order. According to the encoding method, the first user's 13 coded signals

are 2,1,1,2,1,2,0,1,0,1,0,1,0, 7 codes of the first encoded signals are 2,1,2,1,1,0,1, and then we can deduce the 13 encoded signals of 7 codes. At the receiver, we decode the code of user 1, and the address code is (1,2,4,10), that is (1,1,0,1,0,0,0,0,1,0,0,0). According to Eq.(2), we can regain (1,0,1,1,0,0,1). In other words, the whole signals of user 1 can be renewed. Likewise, the remaining 3 signals can be also regained in this way.

The simulation selects the non-return-to-zero (NRZ) code as user's code, and Fig.4 shows the data of four users which are the waveforms at point *A* in Fig.3. The signals are sent periodically. Electrical encoded signal 1 and optical encoded signal 1 (2,1,2,1,1,0,1) shown in Fig.5 are the waveforms at point *B* and point *C* in Fig.3, respectively, which match the theoretical values perfectly.

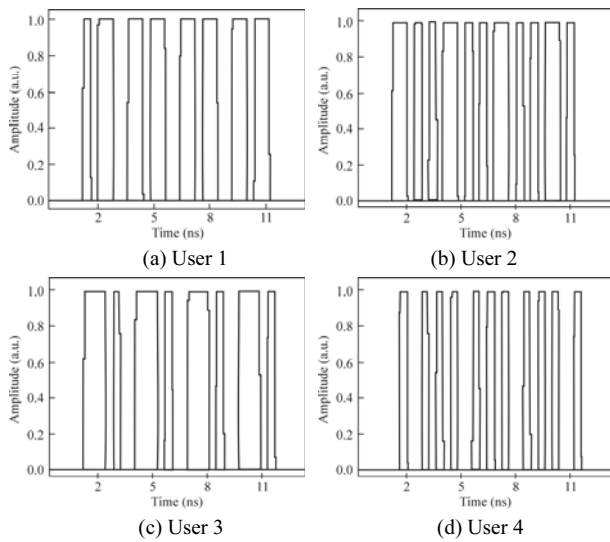

Fig.4 Data signals of four users

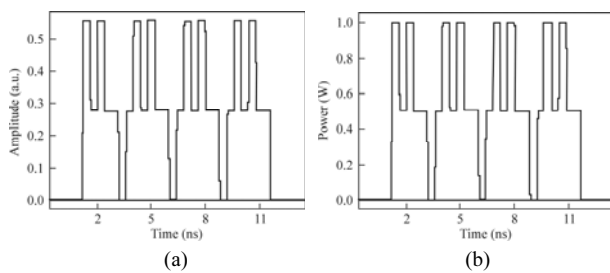

Fig.5 Waveform diagrams of (a) the coded signal 1 and (b) intensity-modulation coded signal 1

Fig.6 shows the 13 encoded signal waveforms by optical coupler, corresponding to the waveform at point *D* in Fig.3. After 50 km optical fibers and amplified by EDFA, the 13 encoded signals are renewed by WDM, and then related encoded signals are restored through optoelectronic detector. In Fig.7, the encoded signal 1 corresponds to the waveform at point *E* in Fig.3. Compared with the signal in Fig.5(b), in the transmission of signals, due to the losses brought by coupling and chromatic dispersion, there are some distortions and burrs in

Fig.7. Besides, EDFA and dark current from photoelectric detector can also amplify the noises. Above factors all have inestimable effects on the signals.

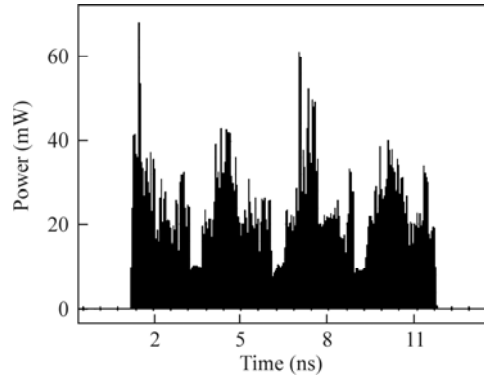

Fig.6 Waveform synthesis diagram of 13-channel intensity-modulation coded signal

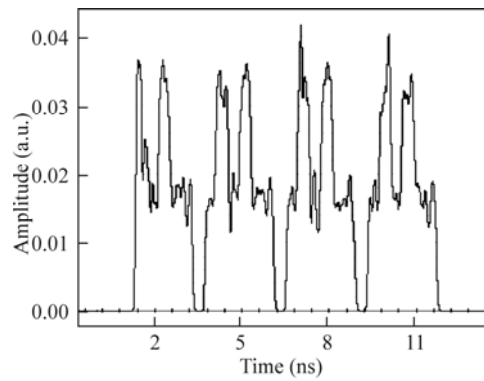

Fig.7 Waveform diagram of encoded signal 1 restored through optoelectronic detector

Users' signals can be regained by electric decoder and weighted multiplier. In Fig.3, the decoder recovers the address codes from every user, and then users can regain the related signals. The waveform diagrams of four users corresponding to point *F* in Fig.3 are shown in Fig.8.

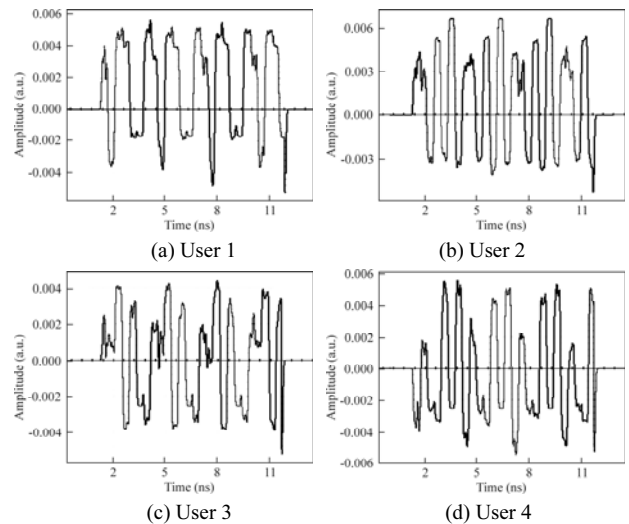

Fig.8 Decoded waveform diagrams of four users

Comparing Fig.4 with Fig.8, we find that the encoded signals accord with the original signals in general, i.e., we decode the data correctly. In addition, there are some distortions and the power becomes smaller in Fig.8, which result from many factors, such as transmission loss, fiber dispersion and EDFA. Insertion loss from devices, reflection loss from FBGs and dark current from photoelectric detector also influence distortion and damping.

In traditional ECDMA technology, the data speed (chip speed) can be calculated by multiplying transmission speed and code length. Code length is the number of usable chips, and it also determines the number of users in system. Since ECDMA program is a direct extension of the time domain, the rate of electrical domain codec must exceed the slice rate, but the processing speed of electric field limits the slice rate. If we increase the code length for much more users, the speed of transmission will be limited. Therefore, speeding up the electric codec is the key of ECDMA. This scheme encodes the user signal in electric domain, optical signals with different frequencies transmit different encoded chips, so in other words, the electrical signal is expanded in frequency domain. The data speed equals the chip speed in this scheme, so speed bottleneck in electric domain can be overcome properly, and the transmission speed can be improved.

In this paper, OOC of (13,4,1,1) designed by our research group is applied to codec, and the relevant theory is verified by simulations. In the case with the speed of user of 2.5 Gbit/s, electric codec can code and decode signals correctly. Finally, electronic bottleneck can be overcome by theory analysis, and this plan is available for OCDMA. Due to the electric codec technology, the programming for this experiment is a good choice. For example, we can use field programmable gate-array (FPGA) because of its powerful parallel processing ability. What's more, the collocation of FPGA is flexible so that it has strong reconfiguration and enormous potential application value in OCDMA electro-optic codec technology.

References

- [1] Tolulope B. Osadola, Sitik. Idris, Ivan Glesk and Wing C. Kwong, *IEEE Photonic Technology Letters* **24**, 395 (2012).
- [2] Li Chuanqi, Zhu Xu, Song Biao, Sun Tingting, Zhao Lilong and Zhu Yingchun, *Acta Optica Sinica* **30**, 660 (2010). (in Chinese)
- [3] Zou Xihua, Pan Wei, Luo Bin and Yan Lianshan, *Journal of Optoelectronics-Laser* **23**, 9 (2012). (in Chinese)
- [4] Li Zhiqian, Cao Ping, Ren Xiaoli, Zhang Jingru and Wang Yalan, *Journal of Optoelectronics-Laser* **22**, 491 (2011). (in Chinese)
- [5] Zhao Lilong, Ren Yafei, Li Chuanqi and Sun Tingting, *Acta Optica Sinica* **30**, s100210 (2010). (in Chinese)
- [6] Li Chuanqi, Chen Hui, Zhou Xu, Zhao Lilong, Song Biao and Sun Tingting, *Acta Optica Sinica* **30**, 2879 (2010). (in Chinese)
- [7] Zheng Jilin, Wang Rong, Pu Tao, Lu Lin, Fang Tao, Su Yang, Zhu Lei, Xiang Peng, Wei Zhihu and Chen Xiangfei, *Chinese J. Laser* **38**, s105007 (2011). (in Chinese)
- [8] C. Goursaud, A. Julien-Vergonjanne, C. Aupetit-Berthelemot, J.-P. Cances and J. M. Dumas, *MAI Impact Suppression with Parallel Interference Cancellation in DS-OCDMA System using Prime Codes*, *IEEE International Conference on Acoustics, Speech and Signal Processing* **4**, 605 (2006).
- [9] K. J. Dexter, D. A. Reid and L. P. Barry, *IEEE Photonics Technology Letters* **21**, 1662 (2009).
- [10] J. B. Rosas-Fernández, J. D. Ingham, R. V. Penty and I. H. White, *18 Gchips/s Error-Free OCDMA Transmission with Electronic Processing for PON Applications*, *34th European Conference on Optical Communication*, 249 (2008).
- [11] Yasuhiro Kotani, Hideyuki Iwamura, Hideaki Tamai, Masahiro Sarashina and Masayuki Kashima, *IEEE Photonics Technology Letters* **22**, 875 (2010).
- [12] S. Kaneko, H. Suzuki, N. Miki, H. Kimura and K. Kumozaki, *Beat-Noise-Free OCDM Technique Employing Spectral M-ary ASK based on Electrical-Domain Spatial Code Spreading*, *Optical Fiber Communication Conference, OTh15* (2009).
- [13] Changjian Guo, Lingchen Huang and Sailing He, *IEEE Photonics Technology Letters* **23**, 953 (2011).
- [14] Li Chuanqi and Sun Xiaohan, *Signal Code Theory for OCDMA System*, Anhui: University of Science and Technology of China Press, 2005. (in Chinese)

[1] Tolulope B. Osadola, Sitik. Idris, Ivan Glesk and Wing