

## Provisioning Quality of Service of Wireless Telemedicine for E-Health Services: A Review

Mustafa Almaedi Algaet · Zul Azri Bin Muhamad Noh ·  
Abdul Samad Shibghatullah · Ali Ahmad Milad ·  
Aouache Mustapha

Published online: 10 April 2014  
© Springer Science+Business Media New York 2014

**Abstract** In general, on-line medical consultation reduces time required for medical consultation and induces improvement in the quality and efficiency of healthcare services. The scope of study includes several key features of present day e-health applications such as X-ray, ECG, video, diagnosis images and other common applications. Moreover, the provision of Quality of Service (QoS) in terms of specific medical care services in e-health, the priority set for e-health services and the support of QoS in wireless networks and techniques or methods aimed at IEEE 802.11 to secure the provision of QoS has been assessed as well. In e-health, medical services in remote places which include rustic healthcare centres, ships, ambulances and home healthcare services can be supported through the applications of e-health services such as medical databases, electronic health data and the transferring of text, video, sound and images. Given this, a proposal has been made for a multiple service wireless networking with multiple sets of priorities. In relation to the terms of an acceptable QoS level by the customers of e-health services, prioritization is an important criterion in a multi-traffic network. The requirement for QoS in medical networking of wireless broadband has paved the way for bandwidth prerequisites and the live transmission or real-time medical applications. The proposed wireless network is capable of handling medical applications for both normal and life-threatening conditions as characterized by the level of emergencies. In addition, the allocation of bandwidth and the system that controls admittance designed based on IEEE 802.16 especially for e-health services or wireless telemedicine will be discussed in this study. It has been concluded that under busy traffic conditions, the proposed architecture can be used as a feasible and reliable infrastructure network for telemedicine.

---

M. A. Algaet (✉) · Z. A. B. M. Noh · A. S. Shibghatullah · A. A. Milad  
Department of Computer System and Communication, Faculty of Information and Communication  
Technology, Universiti Teknikal Malaysia Melaka, Hangtuha Jaya,  
76100 Durian Tunggal, Melaka, Malaysia  
e-mail: elget\_765@yahoo.com

A. Mustapha  
Department of Electrical, Electronic and System Engineering, Faculty of Engineering and Built  
Environment, Universiti Kebangsaan Malaysia, 43600 Bangi, Selangor, Malaysia

**Keywords** Quality of service · Wireless telemedicine · E-health services · IEEE 802.11

## 1 Introduction

This review paper is that e-health technologies and wireless telemedicine systems are carried out and some open survey constraints are detected. A proposal on QoS provisioning in wireless e-health, handoff schemes for QoS support in wireless networks, as well as a proposed scheme of priority for telemedicine/e-health services and techniques/methods for IEEE 802.11 to ensure QoS. And important factor that is studied in this paper is quick delivery of a patient's measurements and mobility support is another important issue for wireless e-health applications.

### 1.1 Wireless Healthcare Information Systems

Information technology (IT) is a key factor in the field of e-health [1]. Most of the latest technological advancement in wireless networking has been utilised by the healthcare sector. Wireless networking plays a vital role in the delivery of information in out-of-hospital incident mainly in the healthcare networking operation as well as the allocation of the useable resources and the assurance of Quality of Service (QoS) for a particular medical application. Healthcare services can be enhanced in underserved areas for instance rural health centre, ships, ambulances, airplanes and home environments by using applications such as electronic health records, medical databases and routing photo/text/video/audio/medical information [2–4]. Vergados [6] have suggested several factors which we should pay attention to when discussing data delivery in wireless medical networking system such as data delivery latency, availability, reliability, confidentiality and privacy; QoS requirements and mobility maintenance.

The accessibility of resources is definitely vital in medical networking systems as the traffic that is generated is highly important for the health and life of the patients. Therefore, maintaining privacy and confidentiality of the customers records need authentication, however these mechanisms are beyond the scope of this study. Besides, it is up most important especially during emergency situations to deliver a patient's records in a fast and reliable way. Furthermore, the mobility support is another crucial matter for wireless e-health programs. For instance, through the application of various wireless technologies an ambulance that travels along various e-health areas namely mobile or static type of connection during the trials can handle various e-health program whereby the connection between the monitoring gadget and the healthcare source of data is maintain throughout.

### 1.2 Handoff Schemes for Quality of Service (QoS) Support in Wireless Networking

Zvikhachevskaya et al. [5] had investigated the implementation of IEEE 802.11 wireless procedures to support QoS in wireless telemedicine or e-health facilities. The prerequisites for QoS provision in wireless medical networking system is very rigid due to the strict prerequisite and real-time nature of healthcare programs. Fast delivery of a patient's data and trust worthiness of data delivered is extremely crucial especially during emergency care. Moreover, mobility supports an important feature for wireless e-health applications. An ambulance travels along various e-health areas carrying various e-health programs. Hence, different wireless technologies are utilised to assure the connection among the monitoring program and the healthcare data source. Moreover, extended researches on the wireless

telemedicine systems and e-health technologies are carried out. Some constraints are detected during an open survey. There should be provision for QoS in wireless e-health, plans for QoS support in wireless networking system and prioritization of e-health services or telemedicine applications for IEEE 802.11 to ensure QoS. Thus, a simple e-health application can function when the user can establish communication on a mobile networking system. The technology used will enable the patients to save on hospital visits and admission, travelling to hospitals, receives professional medical care and help individual at home who need care and treatment.

### 1.3 Provision for QoS in Wireless Medical Data Systems

According to Vergados [6] the next generation wireless networking systems have been launched to render assistance to multimedia services which have a varied traffic features and distinct QoS guarantees. Recently, a special emphasis has been put on medical broadband applications and the ability of continuously monitoring mobile patients has been introduced because of the development in wireless technologies. The emergency nature of the tele medical programs and the bandwidth requirements justifies the need for offering QoS in wireless broadband healthcare networking system. Wireless networking system may assist several e-health programs with varying traffic necessities and features. Simultaneously, wireless networks guarantees QoS. The distribution of resources in e-health applications differs in many ways for instance the type of services offered, propagation characteristics, traffic requirements and networking structure. This study suggests the use of an adaptive resource distribution plan for QoS provision in wireless medical data systems.

Telecommunications and advanced data technologies are mainly utilise for clinical activities and studies so has to enhance medical services. Telemedicine services normally depend on multimedia technologies. Multimedia technologies aim to enhance a variety of multiple clinical applications across diverse network topologies. Different applications require different QoS that is relevant with the type of service rendered in different environmental conditions. This paper proposes a new architecture using wireless technology for multi-class provision of QoS in telemedicine. Resource allocation plan for e-health networking system are expected to afford multi QoS classes according to several e-health programs which are expected to provide services that are highly necessary. Different classes which include best effort, advance forwarding and assured forwarding are enhanced with all the resources which are provided to offer optimum results for each e-health programs. In the wireless health information systems this procedure is carried out based on a logical sequence. First the existing resources in the networking system are determined. After that, analyse the volume, type and QoS prerequisites for the data to be conveyed and lastly tune the applications which the network will handle. Hence, a flexible allocation of resources for a wireless networking system with several kinds of services and priorities has to be set. Prioritization is necessary in multi traffic settings for the allocation of an appropriate QoS level for the customers. Besides, in the attempt to reduce the possibilities of calls being blocked because of bandwidth and to augment the performance of the overall system; upgrading and degrading policies are taken into account. The simulation results will validate the desired performance of the suggested plan. Therefore, the suggested wireless networking system can manage both the normal and life-threatening healthcare plans which are categorised by the nature of their importance. The network will automatically drop or put off the packets so as to fulfil a high level of service in a wireless medical setting corresponding to particular requirement of the healthcare program and concurring to the importance of the medical care required by assigning different levels of priority.

Niyato et al. [7] investigated the application of IEEE 802.16-based broadband wireless access (BWA) technology in telemedicine services and the associated protocol engineering matters. A research on how various development of IEEE 802.16 standard is implemented and several survey matters are stated. Moreover, a research on radio resource management, admission control mechanisms and traffic scheduling accorded for IEEE 802.16/WiMAX systems are discussed. A qualitative comparison between the third-generation wireless networking systems and the IEEE 802.16/WiMAX technology is also included. Furthermore, a survey is also done on telemedicine services using traditional wireless systems. In addition, the merits of using IEEE 802.16/WiMAX technology instead of traditional wireless networking systems; and the related methods and design matters are also discussed. In conclusion, allocation of a bandwidth and procedure controlling the admission for IEEE 802.16-based BWA which is created especially for e-health programs or wireless telemedicine is proposed. This algorithm tends to maximize the usage of radio resources and at the same time give consideration for the requirements of QoS for telemedicine traffic. The operating evaluation for this plan is obtained by using simulations.

They carried out a survey on the overwhelming IEEE 802.16/WiMAX BWA technology, identification of research matters pertaining to radio resource management protocol design, as well as reviewing several current researches in this field. They also discussed applications of BWA access technology in wireless mobile telemedicine services and the operative conditions. In addition, they also review some current researchers on the application and design of wireless telemedicine networking systems and outlined the radio resource management protocol design matters pertaining to using IEEE 802.16/WiMAX-based wireless mobile telemedicine networking systems. In conclusion, they suggest an allocation of bandwidth and a framework for controlling admission in an IEEE 802.16 or WiMAX-based wireless mobile telemedicine networking system. Thus, initial evaluation results for the suggested platform are achieved by simulations.

#### 1.4 Quality of Service Provisioning in Wireless Broadband Healthcare Networking

According to Vergados et al. [8] medical broadband applications have received a lot of attention recently. Besides, introduction of possibility of uninterrupted healthcare observing for mobile patients has paved the path to the splendid development of wireless technologies. Attributable to the real-time nature of healthcare programs and the bandwidth requirement, QoS provided in wireless broadband health-care networking is highly needed. Thus, the adoption of Differentiated Services in Telemedicine is a great challenging decision. Numerous e-health applications with dissimilar traffic conditions may be supported by DiffServ which simultaneously provides QoS security. Resource Allocation in DiffServ aimed at e-health programs is fundamentally different in various features which include the traffic requirements, services provided, preoperational features and network formation. Hence, a new promising DiffServ architecture is acknowledged by this research for providing QoS in emergency Telemedicine system and this research also admits an original architecture for multiclass provision of QoS in Telemedicine by means of wireless DiffServ technology.

Plans for allocation of resource in e-health Differentiated Services networking which tend to afford varied QoS classes that relate to various e-health program intended for enhanced requirement services. Assured forwarding, expedited forwarding and best effort are examples of various classes that are encouraged and resources are allotted to offer an ideal solution for every single e-health application. Thus, life-threatening and standard medical applications that are categorized by their urgent nature can be treated due to the proposed wireless DiffServ

network. In order for an exceptionally good service level to be achieved, different priority levels should be assigned with reference to the importance of the healthcare issue, in accordance to the specific medical application requirements that will guide the network to logically drop and or delay the packets. Thus, architecture that is able to sustain a network which may be utilized well under severe traffic circumstances and as a dependable setup for mobile telemedicine is suggested by Vergados et al.

Su and Caballero [9] focus on developing economical portable or mobile public e-health system for rustic areas. Moreover, access to telecommunication and internet are made possible due to the unification of VSAT (Very Small Aperture Terminal) technology by means of BWA (Broadband Wireless Access). Safeguarding 'connectivity' by these kind of initiatives, for instance three-level medical and health service networking has not only shown to be beneficial to rustic areas, but it could also bring about e-learning, e-health etc. By limiting the digital section, business or service plans are finally heading in the direction of uplifting societies. This study, will also discuss the forthcoming perception aimed at the enhancement of rustic communications which include the relevance of e-health care.

According to Chowdhury et al. [10] owing to efficient multimedia and telecommunication technologies in relation to medical proficiency, providing excellent economical e-health care facilities will be more affordable. Moreover, to apply the future generation Telemedicine and Tele health systems, this research suggests and identifies a telecommunication and networking architecture. Furthermore, to hasten and make instantaneous and near real time transmission of secluded health care data easier, our unified optical wireless networking affords super broadband, super-low dormancy connectivity for image, voice, video and data through countless telemedicine applications.

They suggest a broadband transference and access networking framework intended for the next generation Telemedicine and Tele health plans by means of unified optical-wireless radio-over-fibre technology. It provides protocol-independent connectivity between numerous telemedicine devices that may use the present or developing wireless facilities like 3G or 4G, public safety, LTE, WiMAX and WiFi simultaneously with future proof 60-GHz mm radio waveband for super-low latency real-time transmission of uncompressed super-high clarity video content and images. An experimental demonstration has been identified and the transmission execution of the plan for uncompressed image and HD video transmission using 60-GHz mm-wave radio over 25 kilometre single mode fibre is assessed. It is believed that when established in a situation whereby there is close contact with the medical and healthcare personals, the proposed network system can enable operation of huge classes of the next-generation Tele-health and Telemedicine facilities for first-class, and inexpensive secluded healthcare provision.

Phunchongharn et al. [11] stated that wireless communications technologies, support diverse electronic health applications that transmit patient data and medical information. Two major challenges, however, can be posed when utilising wireless infrastructure in a healthcare setting: The first one refers to the electromagnetic interruption triggered by wireless devices on bio-medical gadgets which may possibly affect their performance critically. The subsequent challenge is related to prioritization of the access to wireless networking by the linking gadgets, since the use of many e-health programs lead to a variety of priorities. They present a new cognitive-radio-based method that addresses these obstacles in wireless transmissions aimed at e-health plans in a hospital setting. Firstly, we have to identify our needs and discuss the possible usage of cognitive radio technology aimed at e-health technology in order for a wireless tele-communications system to be efficiently utilised. After that, we propose a cognitive radio system aimed at e-health programs accessible at a hospital

setting that saves the medical apparatus from hazardous intrusion by familiarizing the transfer power of wireless devices grounded on EMI constraints. Furthermore, network access by two kinds of applications with dissimilar urgencies is advised to use EMI-aware handshaking protocol. Simulation is used to assess the execution of this cognitive radio system directed at e-health application.

In addition, there is a proposal for a cognitive radio system aimed at e-health program. This scheme is concerned with the matters of EMI to healthcare apparatus and QoS differentiation that play a vital role in medical environment. With the intention of accomplishing the expected QoS differentiation amidst various users or applications, the cognitive aptitude of the scheme springs out of its EMI awareness to regulate the parameters of wireless access. The cognitive radio system has taken two e-health programs namely the data system of a hospital and telemedicine into deliberation. Performance assessment outcomes prove that the suggested plan preserves the bio-medical tools from hazardous EMI and fulfils service variation among various e-health applications as well. Incorporating multiple data channels help the cognitive radio system enhance its functions that are its loss and delay probability. Thus, they necessitate a multichannel and multi radio wireless access protocol as well as a developed optimal scheduling algorithm as an alternative to first-in first-out queuing procedure for selection in the cognitive radio controller. Besides, they have to use a procedure for controlling the admission in the system to restrict the number of secondary customers in the networking system. Furthermore, the procedure to control the admission could be created using a transmit power control technique to obtain the utmost system output.

### 1.5 Quality of Service (QoS) in Wireless E-Health and E-Emergency Services

Gama et al. [12] has done a research on the dependable and effective function of e-emergency services or emergency healthcare which requires certain quality control on the networking system and fundamental telecommunication frameworks. Moreover, owing to their unreliable service delivery, most standing wireless body sensor networking systems prove inadequate in fulfilling these requirements. Quality of service support which includes an all-encompassing and trustable aid to patients under health risk should be provided by e-emergency systems. This survey examines the necessity for QoS in e-emergency services and wireless e-health. Besides, certain existing and applicable e-health schemes with QoS prerequisites are stated to justify this need. Furthermore, in this evolving subject of application, this paper highlights the high importance of QoS support, and proposes a sum-up describing the e-health proposals herein given.

Patients' lives are priceless and in regards to that emergency healthcare networking ought to be extremely dependable and efficient. Hence these networking systems must enhance QoS since it is clear that they require dependability, definite bandwidth, and minimal delays owing to their real-time requirements. Moreover, they have developed numerous healthcare systems, although only few deal with QoS support. Conferring to the numerous wireless e-health schemes that are studied, it is proved that QoS support afforded in every method is alternate and treats diverse stages of QoS for particular uses. They also provide a summary that incorporates their key characteristics and objectives herein to make a better comparison of the QoS techniques that has been studied. Nonetheless, the QoS support and progress levels provided by these systems are not sufficient to satisfy an assumed requirement in the hospital units by providing patients who are suffering from health risks and abnormalities with an all-encompassing, valuable, wireless and extremely dependable assistance.

## 1.6 Mobile Healthcare Applications

Soomro and Schmitt [13] stated that owing to mobility of patient, future medical care applications will necessitate operation over heterogeneous networks, with caregiver and healthcare services providers available anywhere, anytime. A unified middleware to segregate applications from client discovery, motion management, and transfer of multimedia traffic which is different from the applications utilizing protocols for particular networking technologies is proposed to be included. They recommend an entire IP-based framework which depends on SIP protocol aimed at unified middleware. The structural design has been defined as well. They define how handovers over heterogeneous linkages can be carried out in this structural design which affords better QoS and low packet losses during transfers. They also identified an experimental prototype to demonstrate the concepts stated above.

Architecture for mobile medical care programs that can function in different networks is identified. Mobility management and session establishment functions of the communication which is stacked into a middleware are included as well. The applications will communicate with and address the end-points using SIP URIs. By applying the SIP URIs the applications are free from the main networks which are utilised to carry multimedia traffic. Additional benefits can be obtained by using SIP-based middleware for instance in network handover transparency and improved QoS. Simultaneously, by offloading session establishment and mobility management functions, applications can be made simpler. A laboratory prototype is built by utilising these theories for real-time monitoring applications for the sick. The results obtained proved the merits of the architecture used and justified the continuous use of sessions which can be used in multi network handover with decreased lost in data compared to the architecture used at the moment. Modification is also done on the prototype to discover data ports which are usable when mobile clients are behind firewalls and NATs. In future a quantitative evaluation of the differences in delays and jitter of various networking systems and their effect on patient monitoring applications should be carried out.

## 1.7 Applying IEEE 802.16 (BWA) Technology to E-Health Systems

Research done by Su and Soar [14] examines the application of IEEE 802.16-based broadband wireless access (BWA) technology to e-health system in the outskirts. A qualitative comparison between third-generation wireless networking systems and the WiMAX technology, as well as a study on telemedicine services depending on traditional wireless systems has been done. Moreover, we discuss the merits behind the usage of WiMAX technology over traditional wireless networking systems, besides the unification of WiMAX technology with VSAT (Very Small Aperture Terminal). Therefore, an admission control algorithm and bandwidth allocation for BWA based on WiMAX which are carried out particularly for wireless e-health services is presented in this paper. Moreover, the evaluation for the usage of resource allocation is attained by simulations.

Furthermore, they suggest a research on the WiMAX BWA technology that is being developed; a discussion on the usage of this BWA access technology for wireless mobile telemedicine services and the possible distribution settings and an outline as well the unification of VSAT with WiMAX technology for e-health in the outskirts. Therefore, they propose an admission control framework and a bandwidth allocation for a wireless mobile telemedicine networking system based on WiMAX. They have started collecting the results for the initial performance of the suggested framework by simulations.

According to Phunchongham et al. [15] the wireless communications technologies, and the efficiencies in the medical healthcare services and patient-care situations can be enhanced.

Nevertheless, two crucial issues may arise out of this use. First off all, the RF transmission may result in EMI (electromagnetic interference) to biomedical gadgets that will malfunction. Secondly, the diverse sorts of e-health programs need varied QoS. To address these issues, this research introduces a wireless access plan know as EMI-aware prioritized wireless access. First of all, we identify the system architecture for the suggested scheme. After that, we suggest an EMI-aware handshaking protocol for e-health devices in the hospital settings. By applying the transmitting power of wireless gadgets based on the EMI constraints, this procedure could protect the biomedical apparatus from damaging intrusion. We also suggest prioritized wireless access plan for channel access for the two different types of applications which have different sets priorities. Moreover, a Markov chain model is used to examine the queuing behaviour of the suggested networking system. After that, this queuing model is utilised to maximize the operation of the system while taking into account the requirements of QoS. Lastly, simulations are used to access the performance of the suggested wireless access plan.

They also suggest an EMI-aware prioritized wireless access plan for e-health programs which takes into consideration two main matters namely QoS differentiation in healthcare settings and EMI to medical gadgets. In addition, we take into account two e-health applications which are EMR applications and clinical alert applications and then develop a queuing analytical model to examine the characteristics of the suggested plan. Results from the performance evaluation prove that the suggested plan can safeguard the active and passive biomedical apparatus from the harmful interference and also achieve service differentiation among diverse e-health applications. The performance namely the loss and delay probability of the suggested plan can be maximizing by adjusting the blocking probabilities. We can as well use the results from the queuing model to maximise the blocking possibilities to optimize the plan output while taking into consideration the QoS requirements of the e-health applications.

### 1.8 A Smart Self-Care Unit for Remote Monitoring of the Health Condition of Patients

Rusu et al. [16] has stressed the need for a well dispersed e-health structure to be designed so as to guarantee remote observation of sick with serious illness and to boost the approachability and excellence of medical services provided. The Smart self-care unit (SSCU) is considered to be a vital factor in this system as it permits remotely obtaining medical information from patients receiving treatment or observed from their personal residence. This component entails a series of well-designed medical radars and devices that are linked by a wireless network. This approach guarantees flexibility for patients who require close supervision and the conveyance of medical information to healthcare facilities such as general practitioners, hospitals, clinics etc. Patients have access to healthcare facilities and may communicate from a distance with healthcare personnel through a dispersed, multi-server established application. With the intention of granting an assimilated medical approach, numerous independent healthcare functions (servers) are set up in each healthcare facility. Medical divisions and self-care units exchange medical records of patients enlisted in this system. This system also provides patients with a portal function that allows patients to access a series of medical services which include protégé keeping of individual's healthcare data, information on doctors, healthcare divisions and their amenities, statistical dealings of noted medical records, and a discussion forum for doctors and patients.

Applying a distributed e-health system is a difficult duty that includes logging in of data and the exchange of information among medical devices, users and applications, remote data attainment and observing. In this particular study, we examine a model of a SSCU



that plays a role in remote observation of patient's health condition. In a sensor networking system, the device gathers the patients and environmental limitations and transfer the data to a healthcare facility for instance clinics, hospitals, general practitioners etc. Distant communication between medical personnel and patients are permitted by the system. The data collected is saved in a specific databank constructed upon the area of ontology. This method criticizes sophisticated dealings amongst variant meanings in the area of healthcare undertaking (episode). The ontology-based resolution guarantees interoperability and a clear sharing of information concerning dissimilar healthcare applications. Moreover, support aimed at improved treatment and medical analysis is granted by healthcare plans associated with domain-specific ontology. Mal-practice incidents may be avoided by medical personnel in the course of assessing, diagnosing and treating patients by using these plans. To assess and treat patients who suffer from cardio-vascular illnesses, the suggested solutions are carried out as well. This theory significantly helps patients decrease the time they spend in hospitals, permits to continuously assess patients with lingering illnesses and eases dependable online communication among the doctors and patients. In future the researches aim to incorporate additional features of intelligence to the structure through statistical assessment conveniences, information mining processes and alternative decision support facilities.

According to Gama et al. [17] emergency and intensive care systems have increased the emphasis on the quality of facility at various levels which includes the MAC layer so as to render reliable assistance to the patients. The Low Power Real Time (LPRT) MAC set of rules proposes appropriate features to tackle these demands owing to low energy usage, effective bandwidth allocation and constrained latency. However, this MAC protocol might still constitute a substantial packet loss ratio in a wireless frequency affected by inaccuracies. A solution is suggested and tested based on short size beacons with the purpose of enhancing its sturdiness to bit error settings. Results prove that we achieve tremendous progress in relation to packet loss ratio and energy conservation. They suggest the use of a new well reconstructed plan which will enable a WSN based on this solution to converse based on a patient's medical state.

The development of LPRT in e-health systems results in low energy usage, data efficiency and contained latency. However, LPRT performance is drastically affected by bit errors as proven by stimulation. The iLPRT established on short size beacons and implied slots apportionment are suggested as well as assessed with the aim of having a MAC protocol which is more robust in comparison to LPRT. Proven by outcomes, iLPRT causes splendid progress in regards to power consumption and packet loss ratio. Nonetheless, the short sized beacon approach is effective only if it does not encompass the reconfiguration of the e-health structure. Hence, iLPRT also involves an efficient reconstructed plan. It is argued that the methods that iLPRT have endorsed are beneficial in improving the provisioning of QoS in e-health networking.

### 1.9 Hybrid Networks is the Real 'Way Out' in Telemedicine Technology

Khan et al. [18] stated the hybrid optical-wireless broadband network (HOW-B) presents promising expectations aimed at medical networking and communication systems. The phenomenon developments in free space optics (FSO) established wireless communication, mobile linkage technologies and medical radars are linked with upcoming biological areas of bioinformatics and telemedicine. Alternatively, a promising path has been paved for life-saving network facilities by the development in optical based wireless technology. The wire-

less networking system accompanied by advance modelling method of patient-care enables the observing of physiological data, continuous patient-care and treatment optimization. All these help to provide effective healthcare and at the same time without interrupting the daily activities of the patients. The RF and FSO networks sustainable connectivity and low-cost optical wireless tele-observing networking system are examined in this particular paper. Moreover, it grants evaluation of the interoperability and QoS surety matters, and the diverse characteristics of optical wireless with (RF) wireless networking systems are compared.

Short range e-health observing program that has 95–98% efficiency can utilise the WLAN–WiFi system. Thus, the tele-monitoring communication networking system can take advantage of a short range for local area monitoring as it is separated by distance. Then, the challenge of future research is the matters pertaining to interoperability that occurs amid the connectivity between the FSO and RF networking. Consequently, a study on interoperability matters can contribute to a better multi operable solution to be used in hybrid networking. In relation to healthcare applications, broadband FSO network technologies can offer enhanced practical answers. The main healthcare communication problems such as security, bandwidth, hold up and installation time have been eliminated by the FSO. Besides, these stand to be highly efficient and compatible with present RF infrastructure. All in all, the suggested notion of hybrid networking system is a real way out in telemedicine technology as RF broadband networking systems do not ensure dependability owing to intrusion and declining bandwidth.

### 1.10 Mobile Telemedicine

According to Batistatos et al. [19] recent researches confirmed the survival of a patient in the course of a health emergency condition relies on the efficiency of the pre-hospital medical care. To tackle this problem, mobile telemedicine utilizes various wireless networking technologies. The characteristics of mobile telemedicine facility provision in a moving means of transportation for example an ambulance is examined in this survey. The distinctive features plus the necessities that are required for it to function are deliberated in terms of merits and demerits to be compared with the existing wireless communication systems that is currently in use. Besides, upcoming wireless broadband communication systems and spectrum access technology are taken into consideration while attempting to enhance the service that is rendered and overcoming the upcoming challenging times.

Mobile telemedicine is a challenging application that has distinct features. Two way real time audio and video communication, high resolution image and healthcare data transfer, seamless and instantaneous pre-hospital care is required. In an actual scenario involving a moving vehicle which is an ambulance from a rustic to an urban location, the network application needs compilation of procedures and technologies which adhere to the requirements of a particular case.

Cobo et al. [20] stated that energy savings is identified as the main goal in most routing procedures in wireless sensor networking and information traffic with unlimited distribution necessities is expected to be provided. The preface of imaging and video sensors, however, uncovers further challenges. Energy saving efficiency and QoS assurance (end-to-end delay and packet loss prerequisites) are both needed for the transfer of video and photo information, so as to guarantee the effective usage of sensor resources along with the reliability of the gathered data. In addition, the research provides a QoS routing model intended for Wireless Multimedia Sensor Networks (WMSN). Besides, an ant-based multi-QoS routing metric (AntSensNet) is created on the traditional ant-based algorithm. Before selecting

appropriate ways to fulfil numerous QoS needs that arise from a diverse type of traffic, the AntSensNet protocol erects an online hierarchical structure, and therefore, this leads to increase network utilization, but improves its performance. Furthermore, to minimise video distortion during transfer, AntSensNet is able to utilise an effective multi-path video packet scheduling. Lastly, to evaluate the efficiency of this new solution, we conduct extensive simulations, and provide a thorough discussion concerning the impacts of diverse system restrictions. This new algorithm has better convergence in comparison to the usual routing algorithms in sensor networking systems and the conventional ant-based algorithm, as it affords more important QoS for several kinds of services provided by wireless multimedia sensor networking.

The splendid speed of technological progress results in the invention of sensors that are skilful enough to sense and produce multimedia data. Although, multimedia information includes sounds, videos, pics, and scalar data—everyone is worthy of its own metrics, these features of multimedia sensor networking rely upon effective approaches so as to meet QoS needs. Provided with such inspiration, this study suggests a QoS routing algorithm such as AntSensNet for WMSNs depending on an Ant Colony optimization platform including a biologically motivated grouping process. In addition, the routing algorithm grants diverse categories of traffic submitted to the applications requirements. The clustering element depends on specific agents (ants) to aid in the choice of CHs in a completely interrupted situation.

When compared with T-ANT this new ant-based clustering algorithm process fulfils CH connection forever with low energy consumptions. Routing includes both proactive and reactive components. In a reactive path setup meant for classes of traffic in the multimedia sensor networking system, the algorithm can choose methods to satisfy the QoS needs; hence, this will enhance network performance. Multimedia information is transferred through the paths found. Throughout the course of transmission, paths are constantly assessed and enhanced in a proactive way. The outcomes of the simulation prove that the ability of AntSensNet outperforms the standard AODV in regard to routing overheads, delivery ratio and end-to-end delay. The results from the simulation adhere to the idea that the suggested mechanism for reduction of distortion which is adopted to transfer video packets leads to a production of better quality video compared to the use of other protocols for multimedia delivery (ASAR and TPGF).

### 1.11 Mobile TLM Architecture

Rashvand et al. [21] has done a study on the emerging wireless network technologies and its use to enhance international health through ways of deployment of a telemedicine framework. They did a thorough research on present wireless and medical sensor technologies in line with the demand for continuous betterment of medical services all over the world generated by population growth and sociological changes. This research conveys the findings that even though there are superior technological solutions these services are mainly so costly and totally insufficient to meet the increasing demand. Besides, it suggests a one-off solution to ensure maximum usage of the future generation of wireless technologies by developing a new harmonized medical framework. Rashvand et al. [21] propose further research to be carried out in the progress of an innovative media-independent ubiquitous wireless telemedicine system so that more cost effective superior quality medical services can be offered (Fig. 1).

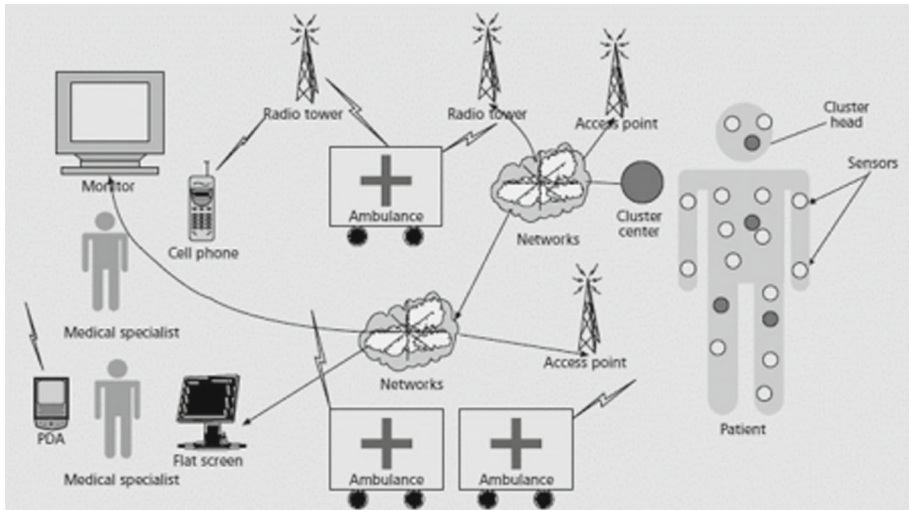

**Fig. 1** Mobile TLM architecture

### 1.12 Instruments for Telemedicine Traffic Transmission Over Wireless Mobile Systems

According to Qiao and Koutsakis [22] in the recent times Telemedicine traffic transmission over wireless mobile systems has seen a great deal of improvement. It is also noted that in contrast to the rest of the traffic in the mobile system, mass communication of telemedicine traffic has the highest delivery importance based on the fact that this kind of traffic brings vital data of the sick. The importance for advance and sufficient delivery of telemedicine traffic requests requires a reliable bandwidth. This makes a compromise between the acceptances of the very strict QoS prerequisites of telemedicine traffic and the decrease in the mandatory bandwidth in multiple situations while it not in use because of the irregular norm of telemedicine traffic. Furthermore, this review encourages a non-bias scheduling instrument for telemedicine traffic delivery over wireless mobile systems. It allows an utmost importance to telemedicine traffic and at the same time the network meets high channel of bandwidth usage.

Zambrano et al. [23] stated that a design methodology for a pilot communications infrastructure to enable Telemedicine services in ambulatory primary health care centres located within “Baruta” and “El Hatillo” municipalities in Venezuela’s Miranda state. The main goal of the suggested infrastructure is to afford voice and data network connectivity between these primary healthcare centres and a chief facility, a local major hospital. The design of the infrastructure is based on a prior evaluation of the physical infrastructure and medical resources available at the ambulatory centres, as well as the features of their surroundings. After considering several other alternatives, a wireless IEEE 802.11 technology is selected as being the most appropriate for this specific application. The used “selection criteria” included characteristics such as technical adequacy, ease and cost of installation and operation, etc. Both physical and logical aspects of the infrastructure are as well included in the design. The design’s performance is testified under the simultaneous use of diverse applications regarding QoS, bandwidth, and delay parameters. Simulations results prove the practicality of the suggested communication infrastructure for this type of primary medical centres.

### 1.13 Two Methods to Solve Decrease Bandwidth Issues

According to Qiao and Koutsakis [24] telemedicine traffic delivers important records about the conditions of the sick; so in comparison with the rest of the traffic in the mobile networking system, it requires the utmost delivery importance. The need for error free excellent delivery of communication on telemedicine traffic needs a secured bandwidth for telemedicine consumers. However, this situation reflects in a compromise between the acceptance of the very strict QoS requirements of telemedicine traffic and the decrease of secured bandwidth in multiple situations where it is left idle because of the irregular basis of telemedicine traffic. This study suggests and concludes the following two methods to answer this complicated issue: (i) an alternative bandwidth backup scheme focusing on geographical data and the mobility of the customer (ii) A non-bias time table plan for telemedicine transmission traffic on wireless mobile systems.

The significant of excellent and advance telemedicine traffic delivery over wireless mobile system in a blink of an eye becomes a very significant thing on account that the real network's ability to provide high QoS deliveries from cellular telemedicine systems. Latest reviews have been paying attention only in the delivery of telemedicine traffic over the mobile systems and not considering about the also significant truth that normal traffic has firm QoS requirements also. Thus, we should reasonably give more thought on effectively unifying of the two categories of traffic to get an effective answer. Plus, this study encourage for a fresh start in the linked literature to the best of our intelligence, the unifying of a non-bias and efficient time tabling plan and an alternative bandwidth reserve plan that allows the unifying of utmost importance telemedicine traffic transfers with normal wireless traffic on mobile systems. This detailed simulation research contains all vital parts of current telemedicine programs such as video, ECG, X-ray and healthcare still pictures and also other common applications for instance audio, visual, email, and internet. Based on the distance based records to provide smooth exchange and also latest schedule plans which are compared based on a hexagonal mobile foundations, they proposed providing maximum importance and fulfilling the very strict QoS prerequisites of telemedicine traffic without breaching the QoS of normal traffic, although there is high circulation burdens.

### 1.14 Test for Wireless Visual and Sound Communication and Quality of Service

Liu et al. [25] stated that the Auxiliary Telemedicine System (ATS) is a promising industry. Their study integrates multiple features in the network mainly due to the global aging demographic tendencies and the needs of the critically sick. For instance, to allow the sick staying at homes to have more medical attention, numeric instruments and data networks should be integrated. Moreover, the professionals can diagnose the patient's condition by utilizing the audio and visual messaging online when he or she requires an online advice. Later, based on the information files in the storage system, healthcare personals can review and conclude. In the ATS, sound and visual excellence is vital for the video messages for interaction. Thus, three tests for wireless multimedia interaction QoS are suggested in this review, and NS2 stimulation software are utilized in the three tests. Based on the end outcomes, it is proven that viral intensity of factors impact on the network QoS involved GOP (Group of Picture) styles, compressed numerical parameters (quantization value), dimension of the package (package dimension) and packet error rate.

This proposal is utilized for monitoring people suffering from diabetes and interacting with the sick and can lead to a more conventional and effective healthcare program. Based on this system the treatment response for the sick can be improved. Blood glucose alert can

enhance the recording of the habitual patterns of the sick. It provides more specific data for the healthcare personals reference when a patient is looking for medical consultation besides increasing self-management. This system can provide first-hand information to the sick and the healthcare personals for further treatment and investigation if there are any traces of abnormalities. On the spot reservation or online medical advice can lower price and the time loss besides efficiently improving the medical service quality and effectiveness. Plus, in an experiment done in this research online healthcare advice or on-line meeting enhance delivery pathways access (EDCA) mode and Differentiated Service (DiffServ) system model. At the same time, delivery of data with the help of the EDCA program is the same as 802.11b distributed coordination function (DCF). However, the contrast is the queue is from a line into four, therefore if the server is available, the waiting line is judged by the Arbitration Inter Frame Space (AIFS), and if extra interval is needed, staying for a reserve with the excuse of a higher importance line to deliver its viable small space, the reserve value randomly produced is lower; therefore there is a higher possibility of competition as it has the right to utilize the server. The real-time data services are immediate; DiffServ model have decreased latency and low package lost frequency so the multimedia information transfer by the networking system will have decreased intervals than the occurring of package delivery interruption. It is hard with the delivery of tiny amounts of missing packages. Multimedia delivery is thus competent to have a specific standard of quality of services. Based on the three tests, numerous reasons can affect the excellence of the networking system's quality of services which include collective visual styles, compression quantization value, the size and the frequency of the package and package error rate. In a GOP, if the I-frame re-delivery of the packet loss causes the recipient's limitations to understand properly, then all the P-frame and B-frame will have problem in understanding it, leading to all GOP in the monitor to become unusable, and visual quality will be poorer. Thus, in the system which deliver visuals, we must take into account the condition of the system before choosing to take up the GOP style; an image programming can be chosen in multiple scales for picture compression; the programing of the numerical scale will be effected by the minimum number of records, but the picture will be of a poor resolution. The amount of information to be transferred will influence the size of each frame that is divided by the number of packets. During a picture transfer, the packets will have an impact on the dimension of each frame. During video conferencing on the Internet, the packet error rate will alter the chances of packet loss and impact the clarity of the pictures.

Putra et al. [26,57] stated that telemedicine network needs an approved networking QoS and cost. IEEE 802.11 wireless LAN technology has been improved to give a matured and reasonable priced system. However, for telemedicine programs the technology has not satisfied the QoS prerequisites yet. It has been suggested that a new multiple layers design of wireless LAN can reduce this obstacle. This design will rely on the IEEE 802.11g standard with improvement made in physical layers and data links. This is carried out in NS2 simulation settings. The tests are done to transport the visual records for telemedicine applications. Simulation test outcomes prove that the latest multiple layer design has a more improved QoS system for Peak Signal Noise Ratio (PSNR) and interruption frequencies than the basic wireless LAN. So, the new build has a possibility to be implemented in telemedicine networking system.

A new cross layer design of wireless LAN is applied and simulated in NS2 settings. The simulation is implemented to transfer the multimedia telemedicine data over IEEE 802.11g wireless LAN. The results obtain from the simulation shows that the new cross layer design can deliver better QoS than the conventional wireless networking system. This is an early sign which shows that the new cross layer design is apt for telemedicine programs.

Balakrishnan et al. [27] stated that information prioritization would be crucial for several emerging applications of wireless and sensor networks (WSNs) that necessitate real-time event monitoring (disaster/intrusion monitoring, industrial automation, telemedicine). The actual QoS literature for sensor applications is still premature, since most of the development efforts are focused on energy efficiency and sensor mote development. In this study, we propose a system configuration of end-to-end QoS in an environmental monitoring network comprising local sensor and back-haul Wi-Fi network technologies. We also identify the performance gains accomplished through rated bandwidth allocation for the sensor information flow across the integrated WSN.

Practical system applications of end-to-end QoS in integrated sensor-Wi-Fi network using off-the-shelf hardware/software solutions. With emerging applications of wireless and sensor networks in emergency tracking (disaster) and real-time monitoring (intrusion), there is a strong need to prove QoS abilities in sensor networks. Also, preserving the data priority across heterogeneous wireless interfaces to fulfil true end-to-end, QoS will be crucial, since sensor deployments would inherently involve long-range wireless technologies for back-haul support.

### 1.15 The Usage of Optical-Wireless Radio-Over-Fiber Technology in Telemedicine and Tele-health Networks

Chowdhury et al. [28] stated that the improvement in the networking infrastructure for efficient next generation e-health applications have been tended to. In addition, they propose unified optical wireless access architecture based on radio-over-fiber technology which provides super broadband, lower latency link among several telemedicine facilities to accommodate real-time and near real time multimedia for remote medical care services.

They suggested a broadband access and transport framework for next generation telemedicine and also tele-health networking systems using unified optical-wireless radio-over-fiber technology. This conventionally offers self-dependent links among multiple telemedicine applications with current or emerging wireless services for instance public wellbeing, Wi-Fi, WiMAX 3G, 4G or LTE together with the next generation 60-GHz mm-waveband wireless and also PON based wired services for ultra-small latency real time delivery of uncompressed excellent resolution video contents and pictures. A demonstration has been carried out as evidence of the concept tested to establish gigabit wireless over fiber link between the high resolution pathological image repository server and remotely located interactive client terminal. Furthermore, they believe that when improved with close collaboration with the healthcare and medical fraternity the suggested converged network system can facilitate new classes of the next generation telemedicine and tele-health services for timely excellent and reasonably priced remote healthcare facilities.

Chowdhury et al. [29] stated that giving excellent quality e-healthcare services requires efficient multimedia and telecommunication technologies along with healthcare professions. They also suggested telecommunication network architecture for carrying out the next generation Telemedicine and Tele health networking. A unified optical wireless type of network gives super broadband, decreased latency connectivity for sound, visual, video and data across multiple telemedicine supplies to accommodate real time and near real time interaction of remote healthcare records.

Based on the unified optical-wireless radio-over-fiber technology, they present a broadband delivery and access networking system for the next generation Telemedicine and Tele-health networks. It can easily offer protocol independent link with multiple telemedicine

gadgets that can use present or emergent wireless services for instance Public Safety, 3G, 4G or LTE, Wi-Fi and WiMAX along with next generation 60-GHz mm-waveband radio for decreased latency real time transfer of ultra-high quality pictures and video files. An evidence of concept testing is carried out and delivery results of the network for uncompressed HD visual and video exchange using 60-GHz mm-wave radio over 25 km single mode fiber is reviewed. They stated that if the proposed coverage network is created with close collaboration with the healthcare and medical services can accommodate applications of higher classes from the next generation Telemedicine and Telehealth services for excellent quality and reasonably priced mobile medical care delivery.

The prerequisites of e-health applications are communication networking systems and high tech user interface skills which can meet the needs of the overwhelming technological advances in healthcare sector [30]. Their proposal analyse the present satellite-based telemedicine networking system, emphasizing on its technical features, e-health services and applications. Gives a general view of the original state-of-the art wireless technologies based on the guidelines given by the Global Economics Forum and various courses for workgroups conducted by International Telecommunication Union (ITU). They also propose a view on network architecture which offers e-health applications and services based on emerging professional wireless technologies. Finally, a review of some next generation applications that utilize the network capacity of the system is also proposed.

This study shows architecture of a network based on advance wireless technologies and the study of present satellite-based telemedicine networking systems. The proposed system will utilize the technical abilities of every technology which allows programmers and researchers to establish a multiple e-health application that is capable to meet the requirements of the up and emerging technologies, resources and methods used in the healthcare sector. These latest services and applications must be given more worth over the current system based on the improved usage of the resources of the network. Ultra mobile equipment are the main component which will pave way to admitting Ubiquitous Broadband links, to have mobility and to be utilized as main framework of individual e-health services and applications.

### 1.16 E-Health Wireless Detector Systems

According to Gama et al. [31] to allow e-health wireless detector networking systems to show significant traffic loads, MAC protocols relying on logical timed algorithms are frequently thought to be more sufficient compared to protocols relying on random access algorithms. TDMA-based MAC protocols can handle the delay besides saving power by avoiding collisions. Nevertheless, these procedures often need some advance planning to place the super frame time-slots to the networking gadgets which are needed to transport data. As shown in this study the sick who are involved in the e-health wireless networking system are usually monitored by the same number and kinds of motes, coming from a normal traffic style, and an easy collaborative allocation of time-slot algorithm. The practice of time-slot allocation done by the management of the networking system can be hindered in this proposed algorithm which may lead to enhance the packet delivery ratio and decrease the power usage in the e-health wireless networking system.

For the benefit of energy conserving and improvement in packet delivery ratio, protocols utilizing small size beacons for example iLPRT is important. A cooperation chain scheduling algorithm can be utilised by the motes of the WSN as allocation of time-slot cannot be stated by a BS transferring short size beacons. Using the normal traffic style used in e-health wireless networking systems, and also the homogeneity relating to the amount and kinds of



motes found in the BSNs of an e-health WSN, a simple collaborative time slot algorithm can achieve this objective. As the suggested arrangements are keyed in, it is sufficient if the motes have limited computational resources. Initial test results shows a decrease in the packet delivery ratio but still is obviously more effective to augment the number of retransmission that need to be done than to decrease the frame size of the beacon. In comparison to a single retransmission, the two retransmissions revealed an astonishing advancement in the QoS of the e-health WSN based on the packet delivery ratio.

Le Gledic et al. [32] noted how to incorporate new technologies into the current regulatory framework remains a long standing challenge for regulators. This is especially applicable to telemedicine and e-health systems. Thus, this survey studies the regulatory framework and a key issue linked to telemedicine and e-health systems progress and suggests potential solutions.

Once considered futuristic technology, telemedicine however a reality is now and is a growing necessity in healthcare practices. Facing user interfaces, technological and reimbursement issues, effective means and adjusted regulatory platform to accompany progress and innovations as well as the assessment of services in telemedicine, are all still needed. Diverse programs have been recently directed or being prepared to better understand requirements, restraints and goals of the different stakeholders [developers, users (patients and professionals), regulators...] applied for the progress of these very particular healthcare products. Intimate relationship and interaction between these stakeholders are key to enhance a tailored regulatory platform permitting innovation.

Sultan et al. [33] also noted that new Information and Communication Technology (ICT) solutions for e-Health are being carried out and effectively used. A great deal of studies interested in this project includes market research, usage studies, and testing. The management of the change process is a vital issue that is frequently overlooked, however it has a direct impact on the sustainability of the new technology. This proposal examines some guidelines based on Social Sciences field which could boast successful implementation of new ICT initiatives in e-Health. A research is conducted on the launching of a mobile medical care management system called myDR (my Daily Record). The case study aims to stress on the value of the change management process and its key role in the progress of new medical schemes. The research shows that when the proper change management mechanisms are in their appropriate place, people tend to use the new system.

As illustrated in this paper, change management highly impacts on the sustainability of new e-health schemes. New habits and routines can best enhance personal change. This study is mostly interested in a mobile telemedicine system that aids to acquire new self-care routines depending on the accessibility and availability of the medical data of the sick. Change management includes several matters for instance evaluation, obstacles, support, results and the context. How these matters can be handled when creating a mobile telemedicine system that guarantees greater chance of success is presented in this research. The main issue is personalizing to the needs of the sick as well as affording feedbacks which are both relevant and timely. The design of new routine should be created based on the findings.

New Information and Communication Technology (ICT) plays a bigger role in effectively carrying out and using e-health [33]. An increased number of reviews and studies are conducted in this field which include market review, functional tests and studies. The management of alternative procedures is one of the vital points which is often neglected, but it still has a significant impact on the sustainability of the latest technology. This proposal reveals some guidelines based on Social Sciences which could enhance successful implementation of new ICT practices in e-health. A research is conducted on the introduction of mobile healthcare administration networking system known as myDR (my Daily Record).

This study aims to stress on the importance of changing the management procedures and its key role in the progress of future healthcare practices. This research also shows that when correct mechanisms of change are administered in the management, the public will prefer the latest networking system.

As illustrated in this paper, changes in management highly impacts on the durability of the latest e-health practices. New habits and routines can best enhance personal change. This study is mostly interested in mobile telemedicine networking system that gives aid to acquiring latest personal care procedures depending on the accessibility and availability of the sick person's health records. Management changes contain several matters including evaluation, administrating, obstacles, help, outcomes and the findings. How these problems can be managed when building a flexible telemedicine networking system that guarantees better possibility of excellence is presented in their research. The main point is individualizing the sick person's needs and also getting response that is both timely and relevant. The making of new practices is carved on these basics.

According to Ros et al. [34] lately there is a need to enhance patient care by incorporating the usage of cellular technological equipment in healthcare facilities such as hospital or clinical applications. The improvement of wireless technology creates a special network of multimedia that can place the prerequisite of e-health networking system's accountability, robustness and precise attention. This presentation allows a responsive wireless technology for healthcare records that allow the sick to enter their instrumentation output data and medical professionals using cellular equipment to enter the sick's information. Plus, cellular and wireless data technologies ideas can be used to response with a healthcare data network for altering present records viewing healthcare equipment are reviewed.

This review proposes a unified ECG monitoring networking system which utilizes cellular computing gadgets as a medium of interaction. The MISN comprises of medical information nodes (MINs) which are linked to a centralised server. Each MIN can be accessed by a cellular computing gadget with a Bluetooth link. The MIN also enables the results of an ECG equipment to be seen using internet browsers and to store the outputs of the ECG equipment into a data file which is saved in the central server. This means that the ECG Instrument's output can be immediately classified into a patient database without further human interaction. Two methods for displaying real-time waveforms using a conventional image format such as JPEG or a custom data format are analysed. Besides, we realize that using a custom data format is to represent an ECG waveform that does not need a high data rate but a custom program to view the ECG waveform. One of the merits of using Bluetooth is that its short range guarantees that only when the user is within a specific location, that the MIN can be accessed. This permits the MIN to afford location particular access to healthcare instruments based on the user's location. We also analyse the Bluetooth Serial Port and Dialup profiles for streaming the real-time ECG waveform data. We recognize that Bluetooth Serial Profile is ideal to be used because it permits further information rate and necessitates less complexity of establishing a connection between the MIN and the MCD.

Mendez-Rangel and Lozano-Garzon [35] did a research on Network Design Methodology for e-health in Rural Areas of Developing Countries. Other than the technical areas that are connected to the general architecture of communication networking system, social factors such as population distribution, public health indicators, public death rate, regional health indicators and many others are also taken into account. Besides, regulatory parameters resulting from the particular requirements of rural zones are also taken into consideration. Thus, the vital features of the proposed technique are:

- (a) delimit the coverage area of the network
- (b) choose available services
- (c) Analyse traffic flows
- (d) Design architecture of the network
- (e) validate the network design

Their research is validated through a case study done at the Cundinamarca department of Colombia.

While examining the related literature, they cannot find a complete methodological guideline that contains the architecture of e-health networking system. Although, some writers have explained after practicing the e-health networking systems, some alteration have to be applied because economic, technical and social issues have not been taken into account. Thus, the architecture for e-health networking in the outskirts of developing countries suggested in the review is different from other studies done in this field since the social and regulatory issues have been taken into consideration in this study. The outcome of their research provides e-health networking system which improves medical services based on the prerequisite of the network area coverage.

### 1.17 Telemedicine Database Monitoring Network

Chih-Jen [36] main target is to improve a telemedicine monitoring networking system; the combination of which mainly has wireless vital signals monitoring equipment, a medical pathway and a medical service information platform. The medical pathway which is one of the three pillars works as the intermediary. The procedure also applies the Open Services Gateway Initiative (OSGi) platform that may grant individual patients dynamically adjust healthcare service programs. Besides, ZigBee-built in wireless nodes are applied in the data transfer between vital signs monitoring equipment and the medical pathway. Vital sign data area which includes SPO<sub>2</sub>, ECG, glucose, blood pressure, and body temperature can be transferred to the medical pathway through ZigBee and then conveyed via the internet to the medical services database platform. This unified medical networking system depends on the concept of Service-Oriented Architecture (SOA) which provides medical management for people. Thus, the senior citizens and the patients with critical sickness can gain from round-the-clock telemedicine services that are provided.

Rotarie et al. [37] examine the understanding of a remote blood pressure and heart rate monitoring system based on wireless devices that are capable of measuring and transmitting a sick person's arterial blood pressure and heart frequency. The use of the proposed technique can be adaptable as part of a diagnostic procedure for long term patient monitoring. The patient will receive medical attention of a critical illness, or it can be applied during treatment from an accident or surgical process. Commercially available devices, decreased energy microcontrollers and RF transceivers are used in order to perform measurements and transmit them to the patient monitoring device. The patient monitoring device which is a PDA carrying a self-heart monitoring program notes the blood pressure systolic and diastolic values and heart rate, activates the alarm when these values exceed the pre-set limits, and interacts regularly with the central monitoring server through GSM/GPRS or WiFi link. A graphical user interface running on the central monitoring server for displaying the measurements is developed. Power consumption is also reduced by the used devices.

This research highlights a prototype of a system used for remote monitoring of heart beat and blood pressure. The system tries to satisfy the users' requirements, redesigning cost and augmenting extensibility and reliability. Despite their main role in collecting data, blood pressure and heart rate monitors are still the most utilized gadgets. Data analysing and processing

are done offline, thus causing the equipment to be inefficient for constant monitoring and early detection of medical anomaly. Such equipment can obstruct an individual's work and his or her comfort because of the wires used between the sensors and the monitoring equipment. For the suggested mechanism information recording and processing are carried out in real time. Moreover, the suggested mechanism uses devices with low power consumption suitable for battery operation and high peak performance. The integrated system affords healthcare for patients' through internet network infrastructures. With the presence of wireless healthcare systems and telemedicine services, continuous and pervasive medical monitoring is now available

Pawar et al. [38] said that a cellular patient monitoring networking system makes use of cellular computing and wireless multimedia technologies for regular or continuous data collecting and reviews of bio signs of a mobile patient. In several trials, these equipment proved that they are easy to handle, precise and effectiveness for both the sick and the professional medical care personals. A general architecture, related terminology and an excellent framework for comparing with mobile patients monitoring networking systems are also suggested in this research. Then this framework is implemented to differentiate six mobile patient monitoring networks chosen based on the following characteristics:

- a. use of multiple mobile multimedia techniques
- b. prove from practical trials
- c. Sufficient published scientific information are available.

Using the epilepsy monitoring as an example, they also explain how to utilize this architecture to identify the characteristics of potential real-time mobile patient monitoring networking systems. Moreover, these studies not survey the healthcare professionals but also computer professionals. Therefore, it provides for healthcare professionals, an overview of the related technical aspects of the mobile patient monitoring networking system and identifies several problems encountered by the usage of these networks. Healthcare professionals can use the suggested framework to differentiate mobile patient monitoring networks and thus determine the characteristic of potential mobile patient monitoring systems which are required to take care of certain healthcare needs. It is assumed that computer experts can gain by understanding better the current inventions in the prevailing areas of mobile patient monitoring networks.

Besides, they suggest a generic framework, related terminologies and classification architecture for mobile patient monitoring networking systems. From the literature, six mobile patient monitoring networking systems are classified according to the proposed framework. A major part of the networking system are accepted to be easy to handle, and convenient to be utilize by both the patients and the medical personals.. However, it is less accepted and lead to annoyance when there is a fault in the network or technical problem. The major issues or analyses are listed below:

- (i) Reported disadvantages of wireless system are linked to insufficient bandwidth for bio signs to be delivered, interruption and absence of wireless network coverage.
- (ii) QoS prerequisite are greatly medical applications which must be specific in nature. The bandwidth needed to accomplish the requested bio signal transmission frequency and the specific quality has been mentioned in some writings but the system interruption and jitter prerequisite need to be identified also for vital medical applications.
- (iii) Major part of the reviewed mobile patient monitoring networking systems are in strong need for urgent solutions to guarantee end-to-end security of bio signal information.
- (iv) The network must be able to avoid missing bio signals during their transfer from the sensors to the back-to-end system networks since it is vital for the doctors to access excellent quality bio signals.

### 1.18 Wireless Communication Equipment Utilized in E-Health Networking Systems

According to Delmastro [39] the advancement of wireless communication technologies leads to the creation of innovative e-health networks that tries to provide constant and remote assistance to individuals and improve the success rate of the medical treatments. This proposal paves a way to the latest review on wireless communication technologies applied in e-health networking system, thoroughly reviewing communication standards, protocols and outcomes which are accomplished in this field. The definition of latest research issues and possible solutions for future e-health systems are being introduced based on the study of pros and cons of present technologies.

Moreover, this study tries to present a current review on wireless communication technologies applied in e-health networks and the emerging situations in future which involves latest requirements and networking procedures. Currently, a study on e-health networks and prerequisites demands the need to define a more personalised and pervasive answers. It tends to improve the quality of life and care for the patients' daily routine and also maximising the productivity of the healthcare staff and workflow. They mainly examine the goals and e-health networking system applications and suggest a patient-entered and hospital centred system framework which can detect the flow of information, their needs and the best interactions that they can carry out. Their research and the practical solutions discussed in the literature review emphasize on the recent study done in this area and also brings out the open issues that have not been settled yet. Currently, solutions are primarily depending on gadgets in the market. Even though using the same communication technology, this leads to a huge need of interoperability among various e-health networking systems and services. Together with industrial partners, the research community works together to set standards and profiles designed for e-health networking systems in order to overcome this obstacle. In conclusion, the outcomes obtained are the general definition for Pervasive Healthcare, collecting data about individual needs, technological inventions and the latest improvements in achieving efficient answers to maximise the present medical services.

### 1.19 Healthcare Delivery Systems Through Telemedicine

Raju and Prasad [40] stated that Information and communication technology (ICT) enables telemedicine to become an efficient model for medical delivery. Regardless their location for remote monitoring and timely diagnosis, patients can network with this technology. In this survey, we elaborate on our telemedicine experiences and endorse methodologies, and stress the diverse design aspects to be taking into consideration for making telemedicine efficient. Hence, it is worth mentioning that according to our study, this technology can be utilized as an accurate screening means for patients at remote centres and undertakes preventive measures for potential patients at risk of cardiovascular disease.

Accurate healthcare delivery systems through telemedicine are mainly due to the communication technology progress which can help patients to be always networked regardless their location. In fact, this leads to remote monitoring and diagnosis for patients with multiple disease conditions, and it involves even patients with implantable devices. A splendid advantage of telemedicine by having networked patients is the availability of timely diagnosis. It is well known that the distance decay effects, i.e., distance in terms of cost and distance acting as a deterrent to people consulting is one important factor that telemedicine overcomes. In rural areas, Telemedicine cannot bring about cure to all the existing problems, but it will certainly assist in handling the vast range of difficulties. A rise in the general awareness of good health across the region can also be guaranteed by Telemedicine owing to the availability of special-

ist opinions. Our initiatives also bring into realization that the same network link serves as an effective way for training of paramedics and nurses, and updating healthcare professionals at remote centres with the latest inventions in healthcare sciences through CME programs.

Chang and Lin [41] stated that in the information society and within the prevailing electronic medical e-health services, the new idea of healthcare services is identified to enhance healthcare and general health. Moreover, in order to deliver e-health efficiently we need to pay attention on the enhancement of internal service system of network. Furthermore, we can separate the e-health transport networking system into three section based on the service blueprint:

- i. support services.
- ii. Intra-organization interaction and
- iii. Contact workers.

The hypothesis used is a good e-health support services in terms of training the workers and IT support programs can effectively increase the worker's service quality which then improves the quality of customers' actions. The role of intra-organizational interactions in terms of e-health service delivery needs to be examined also. We know four kinds of intra-organization interaction in e-health and identify their impact on worker amenity excellence also.

According to Bai and Guo [42] to enhance total quality of services, overall information sharing is an issue that need to be address by the e-health networking system. However, developing e-health network working systems can be hindered by having to share the concepts, vocabulary and its specific definition mainly ontology because e-health is a multidisciplinary and cross organization subject. An information sharing ontology based on the Activity Theory is proposed in this review. It is undeniable that Activity Theory can aid to help to attain a high level and rich ontology for the development of e-health networking system to contain the multidisciplinary and cross organizational information. Finally, they validate their method with their IMIS (Integrated Mobile Information System for Healthcare) which uses the activity theory as ontological framework for the building the entire network.

Ronga et al. [43] studied the unified satellite or terrestrial interactive e-health networking system that has been developed within the architecture of the European Space Agency (ESA) project telemedicine services for HEALTH (TESHEALTH) with the cooperation of the industries, universities and hospitals. The practice of a proper adaptive and accessible heterogeneous networking system which is able to provide the right foundation is analysed, paying attention on the end to end QoS solutions that fulfils a certain degree of quality needed by the telemedicine programs. Furthermore, the improved interactive Service Platform with the objective of exchanging medical data between various services and applications (Self-Care and Assisted Services) contains real time audio and video response between the sick, doctors, and medical staffs. The proposed unified satellite or terrestrial interactive e-health networking system paves way to a new way of relating people to their medical condition, habits and general wellbeing. TESHEALTH networking system offers a scientific medium which can:

- a. analysis an individual's personal health condition and his or her medical records
- b. improve care and results on patient-by-patient principles
- c. allow related medical health activities and to visit the sick where they stay and has the means and services which can support the sick to deal with their own health with mediums and amenities that benefit them when facing their own medical issues, benefiting the medical network.

This heterogeneous networking architecture enables the users especially to have admission to the Service Platform by using different technologies, providing sufficient foundation that meets the required level needed by the telemedicine gadgets and that enhances the implementation of satellite interactions.

Chang and Wang [44] tend to establish and ameliorate an assessment criterion that takes into consideration both the sick and the service providers' view in evaluating e-health service performance. The study architecture reaches the service-profit link by practicing service triangle principle, focusing on the relation between the three stakeholders: the company, the workers and the consumers. Thus, it is assumed that this study may add to the research by offering an e-health service performance evaluation platform that will systematically produce a measurement to review e-health service quality which relates to the value perspectives of many stakeholders and their interactions.

The research done by Liu and Park [45,46] highlights the great demand for a global interconnected e-health architecture and the benefit of supporting guidelines for the design. This proposal demonstrated our techniques for an e-health processing QoS framework for networking system infrastructure management so as to create and implement e-health communication QoS that is secure.

To secure interaction and analytic standard of e-health responses, this review proposes a new technique towards achieving digital health networking services by means of a QoS platform in the management of the networking infrastructure. The very first publication of a list of e-health QoS requirement is stated in this research that has the communication services, processing flows and unified administration. A futuristic workflows and e-health messaging fields are also identified besides the layers of the underlying processing frameworks. Therefore, this study offers important strategies for a transfer from the digital medical test trials into the creation and practice of a global kind of e-health intercommunication infrastructure.

### 1.20 E-Health and Related Opportunities

Khalifehsoltani and Gerami [47] stated that nowadays the quality of services and the life style of people have changed owing to information networks and internet technologies namely e-health which is an effective new approach providing healthcare and medical services for the public and improving the communication among doctors, the sick and all the consumer of the e-health system. Unluckily, even though e-health is not a new trend as it adhered to the most special healthcare sectors, this technology is still thought to be far from the main stream medical procedures. Developing nations are mainly going through many issues in the medical and healthcare services like economy requirements, resources, skills, shortage of medical professionals and healthcare personals In conclusion; they examined the significance of e-health and linked opportunities in the developing nations. Besides, it handles challenges of practicing telemedicine in these nations. The outcomes have been displayed in a new prototype called "e-health Challenges in Developing Countries". Moreover, they will tackle the e-health tactical prototype for developing nations and generalise the presentation tactics. Finally, they stated the experience gained by the developing nations.

Boldly speaking Khalifehsoltani and Gerami [47] also reviewed the multiple layers of utilizing the futuristic Information Technologies and Electronic Commerce which also contains the pros and cons of the e-health networking system. Developing nations must take into account the e-health services in their strategic plan. This review, thus, calls upon the obstacles and chances in a method that improves e-health in these nations. It will aid dogma creators to have improved tactics relating to these ideas.

Noimanee et al. [48] have published their studies on the improvement in the remote healthcare services sector. It is also recognised as e-health for Healthcare Application National Broadband Project. The prototype for this model was carried out at HRH Princess Maha Chakri Sirindhorn Medical Center Nakhon Nayok Province. This model integrates fields such as Telecommunications Engineering, Biomedical Engineering, Computing Engineering and Electronic Engineering and contains both straightforward healthcare and many more. This project is intended in providing healthcare services to the public who reside within the area of radio wave transmission in the location of 2,500–2,520 MHz in Thailand established on global criteria of wireless broadband technology.

Even though, it is difficult to create a networking system that has a WiMAX as base since the disruption in the transfer of radio communications, coordination between companies etc., occurred mainly in the first year of the research, the researchers strived to accomplish their goal and to seek a solution for their plan to advance in their studies. As the pioneer recipients of the research funds from NTC, the researchers have problems in comprehending the framework of the high-speed wireless broadband networking system.

### 1.21 Components of Wireless Telemedicine in an Integrated Network for E-Medicine

Chorbev and Mihajlov [49] proposed a thorough study on the components of wireless telemedicine in a unified network system for e-medicine which was carried out in the Republic of Macedonia. The practice of the latest wireless coverage technology enables the launching of telemedicine services which had previously used cable networks only. To succeed in integrating telemedicine practices, Wi-Fi and WiMAX wireless technologies are adopted. In this research, a summary of the services offered, several proposals and affordable services which are available are clarified. Besides, to use the wireless services, an advanced web programming technologies are widely applied. Instructions are provided for advance applications and enhancement. The accumulated experience shows that wireless telemedicine can work in places or nations with the same economical or natural background.

The citizen of Republic of Macedonia will take a long time before they can rival the developed nations. Actually, e-medicine treads along the growth of other technological fields. Nevertheless, based on proposed framework and also the procedures taken to adopt it, a quick turn point to a modernised networking system which can improve the quality of healthcare services, lower the cost and improve the satisfaction and health of the sick. The usage of wireless technologies in different programs is emphasized in the Republic of Macedonia. Nowadays, with the help of modern wireless telecommunication technologies like WiMAX, the delivery of telemedicine services to locations which cannot be reached before by cables is highly accessible. Hence, it is worth mentioning that thanks to the constantly new prevailing telecommunication technologies and the new software available, telemedicine services which were once desired can now be real. Internet services and XML allow the unification of different Medical Information Systems into a unified networking system for e-medicine. Increased coverage and the accountability of WiMAX help the unification by enabling the hospitals in the outskirts to come closer.

Zhang et al. [50] pointed out that wireless telemedicine also involve mobile health that uses the development in wireless technology to provide medical attention and share health care information whenever and wherever as it able to suppress geographical, organisational and temporal barriers and enable remote analysis and monitoring, exchange of healthcare information and files. Thus, the practice of unified IEEE 802.16/WiMAX and IEEE 802.11/WLAN coverage wireless access technologies and the linked protocol matters for telemedicine services are investigated in this research. Firstly, the IEEE 802.11/WLAN and IEEE 802.16/WiMAX



technologies are analysed and compared thoroughly. Then, issue pertaining to the unified IEEE 802.16/WiMAX and IEEE 802.11/WLAN networking systems, mainly on the QoS aid, management of radio resources, scheduling and network connection management plans, and mobile administration. Lastly, applications and usage of unified IEEE 802.16/WiMAX and IEEE 802.11/WLAN for telemedicine services are discussed.

In addition, the implementation of unified WLAN coverage wireless access technology and WiMAX for telemedicine services and the linked protocol matters are examined in their research. A survey is done on WLAN and WiMAX coverage followed by a comparison on the networks. Their research also examines further reviews related to QoS supports, management of radio resources, time management and network management regulator, and also the management of the WLAN and WiMAX varied system. Finally, possible programs and deployment situations of WLAN and WiMAX varied system for telemedicine services.

Marko and Maija [51] stated that cost effectiveness becomes the main reason behind quality healthcare of the senior citizens. IT can enhance the productivity of health care facilities when applied with care. One instance whereby money can be saved is the nursing of the sick without hospitalization. This review deals with a secured wireless home nursing networking system which can be implemented in diverse health care monitoring tasks.

The general cost of receiving medical attention is increasing as the public mainly in western nations are aging. This development helps scholars to discover new technological solutions to enhance the efficiency as well as the quality of care. A reliable and safe technique that allows the sick to be cared from their home is beneficial, as each hospitalized individual highlights the supply of the current shorthanded facilities. This review provides a network for monitoring the sick from home. Hence it allows freeing hospital space, and at the same time makes the results obtained to be more accountable within specific situations. Besides, to ensure patients' privacy, great attention is paid to develop adequate security measures. Meanwhile, the network offers excellent traceability that is for good measures for legal protection of both the sick and the doctors. Furthermore, it is undeniable that even though technological developments can ensure protection, but the individual need to be given clear instructions on the usage of the networking system in a secured way. To conclude, the hi-tech efficiency for the suggested networking system is excellent and the toll is reasonably priced.

According to Chigan and Oberoi [52] Wireless LANs will be vital in providing coverage anytime and anywhere for various telemedicine programs. This study is interested in allowing QoS over the wireless channel between the Body Sensor Network (BSN) Gateway and the wireless Access Points such as wireless hotspots at different areas. Telemedicine applications normally need the regular information and the information linked to the frequency of emergencies has to be informed to the remote medical care in a timely way. Traditional QoS methods allow sound and information applications; but the irregular nature of the emergency information in telemedicine networking system causes it to be unable to support QoS. This study, firstly examines multiple alternative plans for emergency QoS support in the telemedicine networking system. It encourages an express dual channel (EDC) based QoS delivering technologies. The suggested tool is simple and also has maximum reliable resources. It only displays a small delay for the unexpected emergency information transfer. Test results conclude that the presented EDC based methods shows satisfactory QoS for ubiquitous telemedicine programs.

Furthermore, this study suggests a promising technology to accommodate QoS for telemedicine programs. Planning a protocol to accommodate QoS based on conservative techniques is a highly important matter because of the increased inconsistent nature of these incidents. Solutions cannot be applied for telemedicine applications because the traffic pattern

depending on scheduling traditional QoS. It will produce highly incompetent technique if the resources are saved. Therefore, a dual channel based method whereby the express secondary channel is precisely allocated for delivering short Emergency Alert Message (EAM) which is competent and paves a clear way of giving QoS in omnipresent telemedicine programs. The presented answer uses the IEEE 802.11e guideline as its foundation technology. The test concludes that this technology is not only easy and reliable, but it also produces the smallest interruption from the unpredictable data delivery in telemedicine programs.

Qiao and Koutsakis [53] stated that lately cellular networks have been adopted as a test for the assessment of the quality of low-bandwidth telemedicine delivery. The quick and correct delivery of telemedicine traffic is of vital significance, so telemedicine visuals, sound and data cannot be handled like a normal traffic, but requires top priority for transfer over the wireless channel. On the contrary, if a part of the bandwidth is precisely allocated for telemedicine circulation, this bandwidth will be idle as there is no regular use for communication of telemedicine traffic in the networking system. This review therefore highlights the unification of telemedicine traffic with other kinds of traffic in a cellular coverage. Besides, this research suggests newer schemes for effective transfer of telemedicine traffic.

Skorin-Kapov and Matijasevic [54] stated that e-health services consist of a wide coverage of medical services by data transfer and interactive technology. QoS control mechanism is very vital to make sure the particular prerequisites of such services are met for the purpose of improving current and developing e-health amenities over the diverged Next Generation Network (NGN) framework. Furthermore, this paper assesses the QoS support for e-health amenities in the context of the Evolved Packet System (EPS), precisely by the Third Generation Partnership Project (3GPP) as a multiple access all-IP NGN. It also classifies the varied e-health amenities based on context and coverage QoS needs and suggests a mapping for the present 3GPP QoS Class Identifiers (QCIs) which supports as a foundation for the class-based QoS idea of the EPS. The suggested plan for mapping provides the system administrators with guidance for providing varied e-health service prerequisites. For instance, it proposes the QoS needs for a pioneer e-health services which supports tele-consultation between the sick and the medical personnel and demonstrates the usage of the suggested mapping plans of QCIs in the standardised QoS procedures of control. Owing to its major impact of a person's life and wellbeing, e-health services constitute a genre of services that requires an advanced study on the QoS requirements which is beyond the usual characteristics of individual media flows. It is proven the importance of classifying and prioritising the flows may be determined in reference to the situation in which the service is offered. This study provides some general outlines and makes suggestion for the mapping of e-health service types need to standardise QCIs in EPS as a next generation communication technology. A study of the e-consult services demonstrates the way mapping is implemented

## 1.22 End-to-End Communication Network as a Bridge of Transfer for Electronic Medical Care

Ullah et al. [55] stated that the issue of reliability causes hesitation in the recognition of such services like the e-health services as the use of end-to-end communication networks as a bridge of transfer is uncertain. Besides, a diverse influential dimension that constitutes stringent necessities on the end-to-end communication networking system effects on consumers' view which might obstruct consumers' acceptance. This is known as Quality of Experience (QoE) that relies on the QoS of the end-to-end communication networking system. QoE is as a vital part in determining consumer's acceptance. This research emphasizes and examines features of e-health services and the prerequisites of various QoS needs possible impact of

QoS on QoE. It highly stress on the function of QoS and QoE for the customers' recognition of these services. The problem of non-standardized points relating to QoS specification of areas and linked prerequisites, medically recognized thresholds and the qualitative matters arising in e-health is studied and proposed in their paper. Although multiple types of e-health networking systems have increasing displayed their merits over conservative medical care, acknowledgement of such networks still faces obstacles. Consumers' view represented by consumers' experience level (QoE) has to be enhanced to increase consumers' acknowledgement of e-health services. QoS in e-health programs have been examined for years, however the decreasing foundations for QoS areas is obvious from available literature. This irregular concerning the QoS area verges do not give an effective review of the impact of QoS on the end-user QoE. Thus, a proper classification on healthcare services regarding all significant places, their resultant QoS and QoE areas and their medically recognized verges should be classified and at the same time reviewed to improve consumers view of the given e-health amenity and gets the user's recognition. Thus, a correct technique that integrates the presented instructions for starting QoE reviews in e-health, consumer's participant and other places of QoE are needed to be thought of and their links with QoS should be known.

### 1.23 Importance of Broadband to Enhance Quality of Service in Telemedicine

Salatian et al. [56] stated that broadband is a popular way of telemedicine applied in Intensive Care Unit (ICU) telemedicine. Nevertheless, in outskirts bandwidth needs can easily outdo the income attainable as a large amount of money is required to set up foundation for the system so a lower bandwidth is regular. A negative effect of constricted bandwidth on access is the users are not satisfied. Moreover, handling these obstacles needs to think about QoS problems before an effective ICU telemedicine networking system can be effectively deployed. Quality of Service is based on the package of technology and methods for administrating the networking traffic that aims at providing a specific level of efficiency to a data flow in a networking system. This review, other than discussing the importance of information wavelets as a type of data compression of ICU records, created for an improved usage of broadband in outskirts and in exchange improves QoS in telemedicine.

Broadband is the usual kind of telecommunication applied for ICU telemedicine. Anyhow in outskirts, bandwidth prerequisites can simply decrease the income attainable that is needed to sustain the investment required to upkeep the networking system so a decrease bandwidth is common. Data wavelets is lost data compression method and it allows more effective appliance of the resources of the system such as storage and bandwidth since small files use less time and less space and are quicker to be transferred over a networking system. This network shows great possibilities due to its inspiring outcomes. They agree that it paves the way to the advancement of an ICU telemedicine network for compressing and transferring large amount of data pertaining to ICU monitoring whereby the bandwidth is constricted in the outskirts.

## 2 Conclusion

Quality of service can be identified as the ability to submit the client's needs (constraints) with the best criteria (preferences) established by the client. It is calculated depending on the non-functional characteristics of the service, Telemedicine and relates medical technologies main objectives of affording effective medical care remotely. It should promote the patients'

health conditions and help needy people to consult medical expertise at a lower cost at the appropriate time.

Telemedicine has multiple possible utilizations that is medical, instructive and management. It also for an example, provide excellent medical amenity to neglected places. Views shows that telemedicine can provide answers to a high amount of obstacles including: admitting health care to the public, decreasing the cost of medical care, providing enlightenment and knowhow nearer to the sick, and answering irregular placement of amenity excellence. It can improve results from giving regular and systematic attention to the sick, accurate and productive regular studying for suppliers, and highly productive ways for judgment. Wireless telemedicine is quite a fresh maturing field. Future telemedicine amenity is disproved by the decreased bandwidth or high price of before wireless mediums. The new wireless broadband mediums provide the making of telemedicine amenities which were before only accessible via cable links. Plus, outskirts or disastrous areas, then inaccessible by cable links can make use for improved medical amenities swiftly and with only a quarter of the price before. Thus, wireless telemedicine is precisely fitting for places with less efficient cable links or locations where placing cable connections are hard, frugally unobtainable or basically unachievable. For example, placing WiMAX wireless connections is the only logical method to provide communication and healthcare amenities in situations of natural disasters such as tsunamis, hurricanes, earthquakes etc.

**Acknowledgments** This research was funded by the Ministry of Higher Education Malaysia and Universiti Teknikal Malaysia Melaka under Grant PJP/2012/C-ACT/Y00003.

## References

1. Beecham, L. (1993). Medicopolitical Digest. *BMJ*, 307(17).
2. Maglaveras, N., Koutkias, V., Chouvarda, I., Goulis, D., Avramides, A., Adamidis, D., et al. (2002). Home care delivery through the mobile telecommunications platform: the Citizen Health System (CHS) perspective. *International journal of medical informatics*, 68(1), 99–111.
3. Tripathi, N. D., Reed, J. H., & VanLandinoham, H. F. (1998). Handoff in cellular systems. *Personal Communications, IEEE*, 5(6), 26–37.
4. Xiao, Y., & Li, H. (2004). Evaluation of Distributed Admission Control for the IEEE 802.11 e EDCA. *IEEE Commun. Mag*, 42(9), S20–S24.
5. Zvikhachevskaya, A., Markarian, G., & Mihaylova, L. (2009). *Quality of service consideration for the wireless telemedicine and e-health services*. Paper presented at the wireless communications and networking conference, 2009. WCNC 2009. IEEE.
6. Vergados, D. D. (2007). Simulation and modeling bandwidth control in wireless healthcare information systems. *Simulation*, 83(4), 347–364.
7. Niyato, D., Hossain, E., & Diamond, J. (2007). IEEE 802.16/WiMAX-based broadband wireless access and its application for telemedicine/e-health services. *Wireless Communications, IEEE*, 14(1), 72–83.
8. Vergados, D. J., Vergados, D. D., & Maglogiannis, I. (2006). *Ngl03-6: Applying wireless diffserv for qos provisioning in mobile emergency telemedicine*. Paper presented at the global telecommunications conference, 2006. GLOBECOM'06. IEEE.
9. Su, Y., & Caballero, I. (2010). *Deployment of broadband wireless access for E-health in Chinese rural areas*. Paper presented at the communication systems, networks and applications (ICCSNA), 2010 second international conference on.
10. Chowdhury, A., Chien, H.-C., Khire, S., Fan, S.-H., Tang, X., Jayant, N., et al. (2010a). *Next-generation E-health communication infrastructure using converged super-broadband optical and wireless access system*. Paper presented at the world of wireless mobile and multimedia networks (WoWMoM), 2010 IEEE international symposium on a.
11. Phunchongharn, P., Hossain, E., Niyato, D., & Camorlinga, S. (2010). A cognitive radio system for e-health applications in a hospital environment. *Wireless Communications, IEEE*, 17(1), 20–28.

12. Gama, Ó., Carvalho, P., Afonso, J. A., & Mendes, P. (2008). *Quality of service support in wireless sensor networks for emergency healthcare services*. Paper presented at the engineering in medicine and biology society, 2008. EMBS 2008. 30th annual international conference of the IEEE.
13. Soomro, A., & Schmitt, R. (2011). *A framework for mobile healthcare applications over heterogeneous networks*. Paper presented at the e-health networking applications and services (Healthcom), 2011 13th IEEE international conference on.
14. Su, Y., & Soar, J. (2010). *Integration of VSAT with WiMAX technology for E-health in Chinese rural areas*. Paper presented at the computer communication control and automation (3CA), 2010 international symposium on.
15. Phunchongharn, P., Niyato, D., Hossain, E., & Camorlinga, S. (2010). An EMI-aware prioritized wireless access scheme for e-health applications in hospital environments. *IEEE Transactions on Information Technology in Biomedicine*, 14(5), 1247–1258.
16. Rusu, M., Saplacan, G., Sebestyen, G., Cenan, C., Krucz, L., Nicoara, T., et al. (2009). *Distributed e-health system with smart self-care units*. Paper presented at the intelligent computer communication and processing, 2009. ICCP 2009. IEEE 5th international conference on.
17. Gama, O., Carvalho, P., Afonso, J., & Mendes, P. (2009). *An improved MAC protocol with a reconfiguration scheme for wireless e-health systems requiring quality of service*. Paper presented at the wireless communication, vehicular technology, information theory and aerospace & electronic systems technology, 2009. Wireless VITAE 2009. 1st international conference on.
18. Khan, N., Ashraf, A., Chowdhry, B., & Hashmani, M. (2009). *Survey of challenges in hybrid optical wireless broadband network (HOW-B) for e-health systems*. Paper presented at the information and communication technologies, 2009. ICICT'09. International conference on.
19. Batistatos, M., Tsoulos, G. V., & Athanasiadou, G. E. (2012). Mobile telemedicine for moving vehicle scenarios: Wireless technology options and challenges. *Journal of Network and Computer Applications*, 35(3), 1140–1150.
20. Cobo, L., Quintero, A., & Pierre, S. (2010). Ant-based routing for wireless multimedia sensor networks using multiple QoS metrics. *Computer networks*, 54(17), 2991–3010.
21. Rashvand, H. F., Salcedo, V. T., Sánchez, E. M., & Iliescu, D. (2008). Ubiquitous wireless telemedicine. *IET Communications*, 2(2), 237–254.
22. Qiao, L., & Koutsakis, P. (2009). *Fair and efficient scheduling for telemedicine traffic transmission over wireless cellular networks*. Paper presented at the vehicular technology conference, 2009. VTC Spring 2009. IEEE 69th.
23. Zambrano, A., & Garcia Betances, R. (2012). Municipal communications infrastructure for rural telemedicine in a Latin-American country. *Latin America Transactions, IEEE (Revista IEEE America Latina)*, 10(2), 1489–1495.
24. Qiao, L., & Koutsakis, P. (2011). Adaptive bandwidth reservation and scheduling for efficient wireless telemedicine traffic transmission. *IEEE Transactions on Vehicular Technology*, 60(2), 632–643.
25. Liu, C.-H., Chen, J.-T., Wu, C.-M., & Chen, C.-L. (2009). *The analysis for the auxiliary telemedicine system QoS*. Paper presented at the INC, IMS and IDC, 2009. NCM'09. Fifth international joint conference on.
26. Putra, E. H., Supriyanto, E., Din, J., & Satria, H. (2009). *Cross layer design of wireless LAN for telemedicine application*. Paper presented at the modelling & simulation, 2009. AMS'09. Third Asia international conference on.
27. Balakrishnan, M., Han, D., Benhaddou, D., & Yuan, X. (2010). *End-to-end qos in integrated wireless and sensor network: System implementation*. Paper presented at the communication systems networks and digital signal processing (CSNDSP), 2010 7th international symposium on.
28. Chowdhury, A., Chien, H.-C., Fan, S.-H., Yu, J., Jayant, N., & Chang, G.-K. (2011). *Radio over fiber technology for next-generation e-health in converged optical and wireless access network*. Paper presented at the optical fiber communication conference and exposition (OFC/NFOEC), 2011 and the national fiber optic engineers conference.
29. Chowdhury, A., Chien, H.-C., Khire, S., Fan, S.-H., Tang, X., Jayant, N., et al. (2010). *Next-generation E-health communication infrastructure using converged super-broadband optical and wireless access system*. Paper presented at the world of wireless mobile and multimedia networks (WoWMoM), 2010 IEEE international symposium on a.
30. Cova, G., Huangang, X., Qiang, G., Guerrero, E., Ricardo, R., & Estevez, J. (2009). *A perspective of state-of-the-art wireless technologies for e-health applications*. Paper presented at the IT in medicine & education, 2009. ITIME'09. IEEE international symposium on.
31. Gama, O., Carvalho, P., & Mendes, P. (2010). *A time-slot scheduling algorithm for e-health wireless sensor networks*. Paper presented at the e-health networking applications and services (Healthcom), 2010 12th IEEE international conference on.

32. Le Gledic, S., Fournier, M., Malek, S., & Dupraz-Poiseau, A. (2011). *Telemedicine and e-health systems*. Paper presented at the wireless personal multimedia communications (WPMC), 2011 14th international symposium on.
33. Sultan, S., Mohan, P., & Sultan, N. (2009). *Managing change: Experiences from a new e-health initiative for patients with diabetes and cardiovascular disease*. Paper presented at the world of wireless, mobile and multimedia networks & workshops, 2009. WoWMoM 2009. IEEE international symposium on a.
34. Ros, M., D'Souza, M., & Postula, A. (2008). *Wireless interactive system for patient healthcare monitoring using mobile computing devices*. Paper presented at the Signal processing and communication systems, 2008. ICSPCS 2008. 2nd International conference on.
35. Mendez-Rangel, J., & Lozano-Garzon, C. (2012). *A network design methodology proposal for e-health in rural areas of developing countries*. Paper presented at the proceedings of the 6th Euro American conference on telematics and information systems.
36. Chih-Jen, H. (2008). *Telemedicine information monitoring system*. Paper presented at the e-health networking, applications and services, 2008. HealthCom 2008. 10th international conference on.
37. Rotariu, C., Pasarica, A., Costin, H., Adochiei, F., & Ciobotariu, R. (2011). *Telemedicine system for remote blood pressure and heart rate monitoring*. Paper presented at the E-health and bioengineering conference (EHB), 2011.
38. Pawar, P., Jones, V., Van Beijnum, B.-J. F., & Hermens, H. (2012). A framework for the comparison of mobile patient monitoring systems. *Journal of Biomedical Informatics*, 45(3), 544–556.
39. Delmastro, F. (2012). Pervasive communications in healthcare. *Computer Communications*, 35(11), 1284–1295.
40. Raju, P. K., & Prasad, S. (2012). Telemedicine and cardiology—decade of our experience. *Journal of Indian College of Cardiology*, 2(1), 4–16.
41. Chang, H.-L., & Lin, J.-C. (2011). *Factors that impact the performance of e-health service delivery system*. Paper presented at the Service Sciences (IJCSS), 2011 international joint conference on.
42. Bai, G., & Guo, Y. (2010). *Activity theory ontology for knowledge sharing in e-health*. Paper presented at the information technology and applications (IFITA), 2010 international forum on.
43. Ronga, L. S., Jayousi, S., Del Re, E., Colitta, L., Iannone, G., Scorpiniti, A., et al. (2012). *TESHEALTH: An integrated satellite/terrestrial system for e-health services*. Paper presented at the communications (ICC), 2012 IEEE international conference on.
44. Chang, H.-L., & Wang, Y.-S. (2011). *Assessing the performance of e-health service*. Paper presented at the service sciences (IJCSS), 2011 international joint conference on.
45. Liu, W., & Park, E. (2011). *e-Health service characteristics and QoS guarantee*. Paper presented at the computer communications and networks (ICCCN), 2011 proceedings of 20th international conference on.
46. Liu, W., & Park, E. (2013). e-Healthcare cloud computing application solutions: Cloud-enabling characteristics, challenges and adaptations. In: *Computing, networking and communications (ICNC), 2013 international conference on*, pp. 437–443. IEEE.
47. Khalifehsoltani, S. N., & Gerami, M. R. (2010). *E-health challenges, opportunities and experiences of developing countries*. Paper presented at the e-education, e-business, e-management, and e-learning, 2010. IC4E'10. International conference on.
48. Noimanee, K., Noimanee, S., Wattanasirichaigoon, S., La-oopugsin, N., Mahasitthiwat, V., Thongbunjob, K., et al. (2012). *Development of e-health application for medical center in national broadband project*. Paper presented at the biomedical engineering international conference (BMEiCON), 2011.
49. Chorbev, I., & Mihajlov, M. (2008). *Wireless telemedicine services as part of an integrated system for e-medicine*. Paper presented at the electrotechnical conference, 2008. MELECON 2008. The 14th IEEE mediterranean.
50. Zhang, Y., Ansari, N., & Tsunoda, H. (2010). Wireless telemedicine services over integrated IEEE 802.11/WLAN and IEEE 802.16/WiMAX networks. *IEEE Wireless Communications*, 17(1), 30–36.
51. Marko, H., & Maija, M.-K. (2007). *Wireless system for patient home monitoring*. Paper presented at the wireless pervasive computing, 2007. ISWPC'07. 2nd international symposium on.
52. Chigan, C., & Oberoi, V. (2006). *Providing QoS in ubiquitous telemedicine networks*. Paper presented at the pervasive computing and communications workshops, 2006. PerCom workshops 2006. Fourth annual IEEE international conference on.
53. Qiao, L., & Koutsakis, P. (2008). *Guaranteed bandwidth allocation and QoS support for mobile telemedicine traffic*. Paper presented at the Sarnoff symposium, 2008 IEEE.
54. Skorin-Kapov, L., & Matijasevic, M. (2010). Analysis of QoS requirements for e-health services and mapping to evolved packet system QoS classes. *International Journal of Telemedicine and Applications*, 2010, 9.

55. Ullah, M., Fiedler, M., & Wac, K. (2012). *On the ambiguity of Quality of service and quality of experience requirements for e-health services*. Paper presented at the medical information and communication technology (ISMICT), 2012 6th international symposium on.
56. Salatian, A., Adepoju, F., & Oborkhale, L. (2011). Using wavelets to improve quality of service for telemedicine. *International Journal of Advanced Science and Technology*, 27(34), 2005–4238.
57. Putra, E., Supriyanto, E., Din, J., & Satria, H. (2009). *Cross layer design of IEEE 802.11 e enhanced distributed channel access wireless network for telemedicine application*. Paper presented at the innovative technologies in intelligent systems and industrial applications, 2009. CITISIA 2009.



**Mustafa Almahdi Algaet** received the B.S. degrees in electrical engineering from Almahdi university of Libya, in 2004 and the M.S. degree in information and Communication technology from University Utara Malaysia, Malaysia (UUM), in 2006. Currently, he is PhD student at UTeM. His research interest is Quality of service (QoS) in wireless telemedicine.



**Zul Azri Bin Muhamad Noh** is a Senior Lecturer teaching Advanced High Performance Networks, Network Routing, Implementing and Administering Active Directory, and Wireless Network and Mobile Computing. Dr. Zul Azri's education was first in Bachelor of Engineering in Electrical and Computer Engineering, then Masters of Engineering in Communication and Computer Engineering, then Doctor of Engineering in Communication and Computer Engineering, all from Nagoya Institute of Technology Japan. In October 2007, while pursuing his PhD, he joined UTeM as lecturer at Faculty of Information and Communication Technology. Currently, he is head of Advanced Networking and Distributed System research cluster. His current research interests include quality of service (QoS), wireless LAN, packet scheduling algorithm, and multimedia communication.



**Abdul Samad Shibghatullah** is a Senior Lecturer in faculty of information and communication Technology UTeM, and his PhD Degree in computer science (Brunel University, UK) 2008, Msc Computer science (UTM) 2001, B.Acc (UKM) in 1999, and his field is Scheduling and Agent Technology.



**Ali Ahmad Milad** received the B.S. degrees in computer science from Almergib University in 2005, and the M.S. degree in computer science from University Putra Malaysia, Malaysia (UPM) 2009, currently; He is Ph.D. student at UTeM. His research interest is Very High Speed Wireless LANs. MAC protocols.

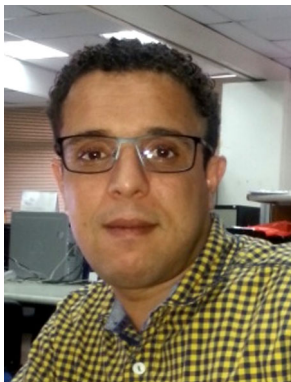

**Aouache Mustapha** was born in Frenda, Algeria; received the B.Sc. (2000) in Control and Automation from University of Boumerdes (UMBB), Algeria; M.Sc (2006) and PhD (2012) in Electrical, Electronic & System Engineering (EESE) from Universiti Kebangsaan Malaysia (UKM). Currently he is a Post-Doctoral at EESE Department, UKM University, Malaysia. He is member in Smart Engineering Systems Research Group (SESERG) and Digital Signal Processing (DPS)-UKM University Malaysia. His research interests are intelligent systems, medical image processing, diagnostic systems, pattern recognition and communication system.