

An overview of spectrum sharing techniques in cognitive radio communication system

Shweta Pandit¹ · G. Singh¹

Published online: 29 December 2015
© Springer Science+Business Media New York 2015

Abstract As the complexities of wireless technologies increase, novel multidisciplinary approaches for the spectrum sharing/management are required with inputs from the technology, economics and regulations. Recently, the cognitive radio technology comes into action to handle the spectrum scarcity problem. To identify the available spectrum resource, decision on the optimal sensing and transmission time with proper coordination among the users for spectrum access are the important characteristics of spectrum sharing methods. In this paper, we have technically overviewed the state-of-the-art of the various spectrum sharing techniques and discussed their potential issues with emerging applications of the communication system, especially to enhance the spectral efficiency. The potential advantages, limiting factors, and characteristic features of the existing cognitive radio spectrum sharing domains are thoroughly discussed and an overview of the spectrum sharing is provided as it ensures the channel access without the interference/collision to the licensed users in the spectrum.

Keywords Cognitive radio · Dynamic spectrum access · Opportunistic spectrum access · Wireless communication · Spectrum sharing · Spectrum sensing

1 Introduction

Recently, the spectral resource demand has been greatly increased due to the emerging wireless services and products in the market. However, the frequency allocation charts reveal that almost all the frequency bands have already been assigned and the traditional static spectrum allocation strategies cause temporal and geographical holes [1] of the spectrum usage in the licensed bands. However, it might be possible that at certain time or space, some of the spectrum allocated to a certain service is unutilized and because of the fixed spectrum allocation scheme, the other user/service provider cannot use this unutilized spectrum. Therefore, the spectrum is not scarce but the inefficient utilization of the allocated spectrum leads to the spectrum scarcity problem. The limitations of fixed spectrum allocation based scheme have been discussed in detail in [2]. To overcome the aforementioned limitations of the fixed spectrum allocation scheme, the concept of dynamic spectrum access (DSA) [3] and opportunistic spectrum access (OSA) [4] have been introduced, which defines a set of techniques and models to support the dynamic management of the spectrum for wireless communications systems. Therefore, the cognitive radio evolved as a technique to improve the overall spectrum usage by exploiting the spectrum opportunities in both the licensed and unlicensed bands. It starts with the sensing of radio frequency (RF) medium—radios are able to exploit information about the wireless environment to be aware of local and temporal spectrum usage.

The opportunistic users may dynamically select the best available channels, and adapt their transmission parameters to avoid harmful interference between the contending cognitive users. Therefore, the cognitive radio is a promising wireless communication technology geared to solve the spectrum scarcity problem by opportunistically

✉ G. Singh
drghanshyam.singh@yahoo.com
Shweta Pandit
ershsweta3@gmail.com

¹ Department of Electronics and Communication Engineering,
Jaypee University of Information Technology,
Waknaghat, Solan 173 234, India

identifying the unused portions of the spectrum. It observes, learns, optimizes and intelligently adapts to achieve optimal frequency band usage and establish communication, while ensuring that the licensed or primary users of the spectrum are not affected [2]. It is able to operate in multiple frequency bands and maximize the utilization of the limited radio spectrum while accommodating the increasing number of services and applications in the wireless communication systems. The driving force behind the cognitive radio technology is the new spectrum licensing methods initiated by the federal communication commission (FCC), which is more flexible to allow the unlicensed (or secondary/cognitive) users to access the spectrum as long as the licensed (primary) users are not interfered by the unlicensed users [5]. This new spectrum licensing method significantly improves the utilization of frequency band and enhances the performance of wireless communication systems. However, the potential deployment of cognitive radio networks has been further augmented through various standardization activities supported by the IEEE-(IEEE 802.22, IEEE 802.16 h, IEEE 802.11y, IEEE 802.11af), and directives of spectrum regulatory agencies. These aforementioned standardization efforts opened portions of the spectrum for opportunistic spectrum access and laid down rules for sharing the spectrum potentially for various novel and promising applications such as smart grid, machine-to-machine, vehicular networks, public safety networks and emergency networks.

Various research communities have different definitions of the cognitive radio and each community has unique view with its defining features. According to the communication theorists view, the cognitive radio is primarily concern with the dynamic spectrum sharing, while the networking/information technology researchers interpret cognitive radio as a device capable of cross-layer optimization, the computer scientists picture it as a device capable of learning and adapting with assumed capabilities, while the hardware/radio frequency community often views it as an evolutionary step from Software Defined Radio (SDR) [5–9]. Basically, the fundamental concept of cognitive radio has been adopted from the SDR, which can operate on multiple frequency bands without any hardware modification, however the selection of frequency band and operating parameters is manually controlled by the user through the software. The artificial intelligence part for learning and decision making is not available in SDR in contrast to the cognitive radio, which is the software defined radio along with the capability of sensing their environment and making decision such as about modulation scheme, transmission power etc. without human intervention. A primary network is not aware of the cognitive network behavior and it does not need any specific functionality to coexist with it. When a primary user is detected, the cognitive users should

immediately react by changing their RF power, rate, codebook, used channel, etc. because their transmissions should not degrade primary user's quality-of-service (QoS). Moreover, the cognitive users should coordinate their access to the available spectrum/channel and avoid collisions between different cognitive radios.

There are various applications proposed for the deployment of cognitive radio network in coexisting/shared basis because of their highly underutilized spectrum such as television, microwave point-to-point links and land mobile radio. The cognitive radio based communication standard IEEE 802.22 WRANs (Wireless Regional Area Networks) is discussed in [10] which allows the coexistence of television users and cognitive radio users for wireless internet access. The cognitive radio users can use the television band for Internet applications in rural areas when it is unused and is advantageous to have broadband internet access over these television white spaces, otherwise separate broadband network deployment could be difficult and costly in rural areas. This technology can also be applied for e-health services [11], intelligent transportation system such as VANET (vehicular ad-hoc network) [12], emergency [13] and military services [14]. Zhao and Sadler [3] have described the basic aspects of the DSA with regulatory issues and Akyildiz et al. [15] have provided the brief overview of cognitive radio technology and its functioning. Further, the authors in [16] have overviewed the different spectrum sensing techniques and spectrum sharing domain has been briefly explored. In this paper, we have technically overviewed the state-of-the-art of various spectrum sharing/management techniques in detail and discussed their potential issues with emerging applications of the communication system, especially to enhance the spectral efficiency and fairness among the users. The sharing techniques which are employed by cognitive users or network are: (1) power control method, (2) game theory, (3) multiple antennas, and (4) medium access control (MAC) protocol. In particular, Sect. 2 describes the spectrum sharing model in cognitive radio network. Further, in Sect. 3 different domains of spectrum sharing are described. Section 4 shows the related work done by researchers in the direction of throughput/capacity enhancement of the cognitive radio system and Sect. 5 concludes the paper and explores the future scope.

2 System model for spectrum sharing

The shared nature of wireless channel requires the coordination of transmission attempts among the cognitive users. However, the main functions of cognitive radio are classified into three classes [15]: (1) Spectrum sensing, (2) spectrum sharing/management and, (3) spectrum mobility. With

reference to the knowledge of spectrum band utilization, the authors in [2] have explored three potential approaches such as database registry, beacon signals, and spectrum sensing to identify the spectrum opportunities. The database registry method requires the GPS (global positioning system) mounted on unlicensed devices to determine its location and accesses the database of primary network to detect the licensed channels that are vacant at that location. However, there are some potential challenges associated with the database registry method to detect the spectrum opportunities such as: (1) need of new commercial entity to be built and maintained database, (2) cognitive devices need to know their location with prescribed accuracy which is difficult for indoor GPS enabled devices, and (3) devices need additional connectivity in a different frequency band in order to be able to access the database prior to any transmission in the licensed frequency band. Further, for detecting the spectrum holes with beacon signals, the potential challenge is that an unlicensed device transmits if it has received a beacon (control) signal and identifying unutilized channels within the service area. However, without reception of the beacon signal, the unlicensed user transmission is not permitted and it keeps unlicensed users waiting even when the licensed spectrum is not occupied in case of hidden terminal problem, and the beacon infrastructure should be maintained either by a licensed operator or by some other operator adding extra cost factor. However, the spectrum sensing approach is best among aforementioned approaches to yield the unused channel because unlicensed users autonomously detect the licensed spectrum and no modification to the existing infrastructure of a licensed system is required. Therefore, the dynamic spectrum access through the spectrum sensing is compatible with legacy wireless communications systems.

The spectrum sensing approach is used in various cases along with database registry method to know the utilization pattern of the licensed channels. The spectrum sensing is the capability of cognitive radio to detect the available channels within the pre-existing systems (licensed bands/primary users band) and various dimensions of the sensing such as time, space, angle-of-arrival, code along with frequency have been explored for full-awareness about the spectrum. For example, (1) in time-dimension: an opportunity of particular spectrum band to be unused by licensed users in specific time has to be sensed, (2) in space-dimension: particular band to be unused by licensed users in specific geographical area has to be sensed, and (3) in code-dimension: even if a band is occupied in time, frequency and space dimension by licensed users, it can still be used by the cognitive radio users by using free spreading code or hopping sequence. The spectrum mobility allows the cognitive radio users to switch to other unutilized frequency band in case of primary user appearance between cognitive radios communications.

The key component of dynamic spectrum access in cognitive radio technology is spectrum sharing, which is responsible for an efficient and fair spectrum allocation or scheduling solutions among the licensed users and cognitive users. In the spectrum sharing model, the radio spectrum is shared between the primary user network and cognitive user network, simultaneously. However, the unlicensed or cognitive users can opportunistically access the radio spectrum if it is not occupied or fully utilized by the primary users. In other words, as long as the unlicensed user does not interrupt the primary user by maintaining the collision probability below the target level, the spectrum access by the unlicensed user is allowed and it remains transparent to the primary user. However, such type of sharing takes place without the primary users being aware of cognitive users i.e. the transmissions of cognitive user are having minimal impact on the operating conditions for which the primary user devices are designed. This model of spectrum sharing is attractive as it increases the spectrum access/spectrum utilization and also assures the co-existing with existing legacy systems. However, various parameters of the cognitive network system model for spectrum sharing are shown in Fig. 1 and are as follows.

2.1 Cognitive radio network architecture

The architecture of cognitive radio network is an important aspect for sharing the licensed spectrum with multiple cognitive users. There are mainly two types of cognitive radio network architecture which is described as follows [2].

2.1.1 Centralized cognitive radio network

In the centralized cognitive radio network, the control of spectrum allocation and access to a particular regime of the spectrum by cognitive users is performed by a central controller, for example, a base station [16, 17]. In addition to this, all the cognitive user's communication are followed through this central controller and the spectrum access decisions like duration of spectrum allocation and transmit power by the cognitive user is controlled through the central base station. For this purpose, the central controller needs to collect information about the spectrum usage of the licensed users as well as information about the spectrum requirements of the cognitive users. An optimal solution, based on this information maximizes the total network throughput, provides QoS, reduce latency etc., can be obtained. The decisions of central controller are broadcasted to all the cognitive users in the network. However, the information collection and exchange to and from the central controller and the cognitive users incur a considerable overhead [2].

Fig. 1 Spectrum sharing system model for the cognitive radio communication system

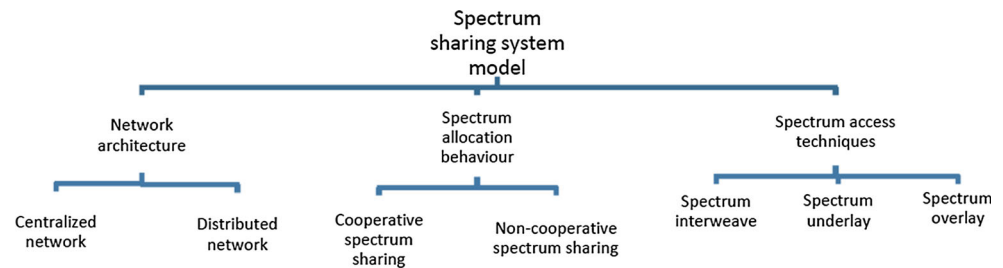

2.1.2 Distributed cognitive radio network

In the distributed cognitive radio network, the cognitive users communicate with each other directly that is in a peer-to-peer manner without requiring any base station or central controller [2, 16]. However, the cognitive user can make a decision on spectrum access independently and autonomously. Since each cognitive user has to collect information about the ambient radio environment and make its decision locally, the cognitive radio transceiver of each cognitive user requires more computational resources than that required in the centralized network. However, the communications overhead in this case would be smaller. In the multi-hop communication, the cognitive users sometimes may be assumed as relay stations [2].

2.2 Spectrum allocation behavior

2.2.1 Cooperative spectrum sharing

In the cooperative sharing scheme [18], all the cognitive users cooperate with each other either through a centralized base station or through a common control channel in the centralized or distributed cognitive radio networks. The cooperation between cognitive users is performed to share the spectrum with maximum efficiency by exchanging the sensing information with each other and thus the cooperative spectrum sensing [19] reduces the sensing time while improving the spectrum sensing accuracy, incurs good degree of fairness, higher complexity, and overhead with an increase in the energy consumption [20]. However, in order to reduce the communication overhead, complexity and power consumption in the cooperative spectrum sensing only those sensing information is used, which is useful in determining the primary user's presence [21].

The communication overhead is further minimized in the cognitive radio spectrum sharing system through clustering [22] in which the spectrum sensing results are combined and processed locally by the cluster head. The cluster head of each cluster, reports the result to a central controller to make the final decision regarding the channel access. However, some other techniques have been proposed for sharing the spectrum by combining the spectrum

sensing results of different cognitive users and making decision of sharing spectrum based on the cooperative sensing and simplest one is to use an OR operation among the received sensing results [23], and weighted data based fusion [24]. The sensing and combining techniques based on maximal ratio combining (MRC) and equal gain combining (EGC) with the help of multiple antennas under different fading channels are explored in [25] and demonstrated that this method improves detection probability of the primary users.

2.2.2 Non-cooperative spectrum sharing

In comparison to the cooperative spectrum sharing, in this spectrum sharing method the cognitive users do not exchange any kind of information with each other. However, this method of sharing is advantageous for less number of cognitive user's network and provides less communication overhead, but in the multiuser network it causes severe degradation of spectrum efficiency because of the selfish nature of each cognitive user. Since the spectrum sensing information of single user is utilized to make decision for sharing the primary licensed channel, therefore the probability of false-alarm is significantly more in the non-cooperative spectrum sharing in comparison to that of the cooperative spectrum sharing method and results the performance degradation of either primary or cognitive user.

2.3 Spectrum access techniques

In a shared-use model, the spectrum can be accessed by the cognitive user in three different modes [2], namely, spectrum interweave/opportunistic spectrum access, spectrum underlay and spectrum overlay, which are discussed in detail as follows.

2.3.1 Spectrum interweave/opportunistic spectrum access (OSA)

At a particular time, frequency or space, if the spectrum is not utilized by the primary user, it can be opportunistically accessed by the cognitive users with the help of spectrum

interweave access method [26, 27] as shown in Fig. 2(a). Therefore, in order to access the regime of spectrum using the spectrum interweave technique, the cognitive user has to perform spectrum sensing to detect the activity of a primary user in that regime.

If a spectrum hole that is inactive primary user is detected, the cognitive users may access that unutilized spectrum as is shown from Fig. 2(a). Once the primary user resumes its transmission, the cognitive users must have to vacate the spectrum. The spectrum interweave method is used by the cognitive radio in frequency division multiple access (FDMA), time division multiple access (TDMA), or orthogonal frequency division multiplexing (OFDM) wireless communication systems.

2.3.2 Spectrum underlay

In the spectrum underlay access method, the cognitive users transmit concurrently with primary user as shown in Fig. 2(b). However, the transmit power of cognitive user should be limited so that the interference caused by the cognitive users to the primary users remain below the interference temperature limit [26]. The interference temperature is defined as the interference limit set at primary user’s receiver up to which it can tolerate interference without affecting their operation. The spectrum underlay technique is used for cognitive radio systems using code division multiple access (CDMA) or ultra-wide band (UWB) technology [2]. Therefore, in the spectrum underlay access technique, the spectrum sensing to detect the spectrum hole for cognitive users transmission is not

needed, however, threshold level for the interference avoidance is required.

2.3.3 Spectrum overlay

In the spectrum overlay mode of spectrum access method, the concurrent primary and cognitive user’s transmission are allowed as shown in Fig. 2(c). However, the interference at secondary and primary receiver is mitigated by the advanced pre-coding and interference cancellation techniques as discussed in [28–30]. Although, the spectrum overlay is a promising spectrum sharing technique, it requires high degree of cooperation with primary users and requires knowledge of primary user message signal. In addition to this, the cognitive users helps to relay the primary user’s information by utilizing some part of its power and remaining power for transmitting its own data [31, 32] in this technique. Therefore, the increase in primary user’s SNR due to relaying is balanced by the decrease in its SNR due to cognitive user’s interference resulting in same SNR at primary receiver without cognitive user. Hence, the primary user is unaware about the cognitive user’s presence. The dirty paper coding [33] is used by cognitive transmitter to mitigate the interference at cognitive receiver.

3 Different domains of spectrum sharing

The spectrum sharing plays a major role in the cognitive radio communication systems and it can be performed by using various techniques. However, the implementation of

Fig. 2 The spectrum access techniques **a** spectrum interweaves, **b** spectrum underlay and, **c** spectrum overlay approach

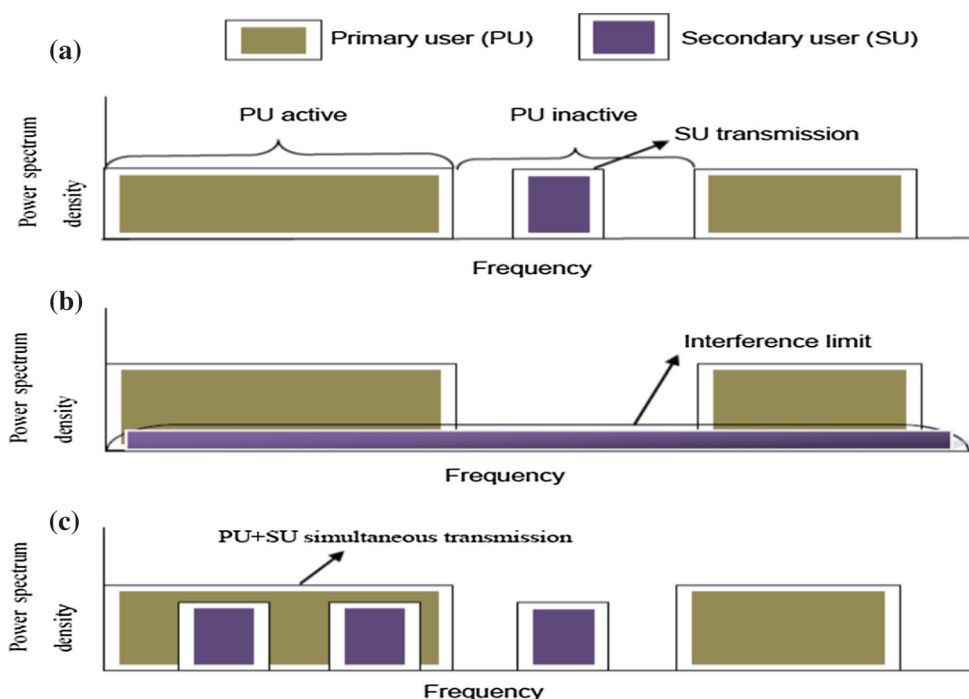

a particular spectrum sharing technique depends on the QoS requirements. In this section, various sharing techniques are presented as follows.

3.1 Power control

The cognitive radios must follow the rules/restrictions to access the spectrum [2] and the management of protocol as well as a reliable and scalable mechanism, which allow a cognitive user to follow the rules, is required. However, in case, the protocols are violated then proactive and reactive techniques of power control is used to avoid this misbehavior. A proactive technique includes the rule (for example, maximum power limit) and an enforcement mechanism (power allocation), however this proactive technique is applied before the cognitive radio users start misbehaving that is before violating the spectrum access rules. On the other hand, a reactive technique is required to punish the misbehaving cognitive radio. Since the cognitive users coexist with the primary users in an operating spectrum, mere consideration of transmission power limits on a channel may not be sufficient [34]. The presence of primary users in the adjacent channels forces to reduce the demand for signal power transmission on an available channel for minimum adjacent channel interference. Hence, the occupancy of the neighboring channels is a critical parameter for the improved spectrum sharing in transmit power mode. Further, in the opportunistic spectrum access transmission model, the cognitive user can transmit only when it detects the spectrum holes, which is the time duration that primary user is not transmitting over the band. However, in [35], the authors proposed a new spectrum sharing transmission model in which the cognitive user can transmit at any time without detecting that primary user, which is active or not but it has to restrict its transmission power so that the harmful interference at primary user is avoided. This consideration is good for the case when the perfect channel state information is not available and it is similar operation as that of Ultra-Wide Band (UWB). However, the restriction on the transmit power decreases the transmission range of the cognitive radio user data and could not take full-advantage of unutilized licensed spectrum in which it can transmit with maximum power. Therefore, the authors in [36] have proposed that the sensing is performed to vary the transmission power of the cognitive user, so that when the primary user is active, the cognitive user transmits with low power to avoid the interference at primary user and vice versa. In addition to this, the wrong/partial channel information results the degradation of cognitive radio system performance [37].

Further, the adaptation in transmission power and rate according to fading conditions is discussed in [38, 39].

Kang [40], have determined the optimal power allocation to cognitive users under Rayleigh fading environment with the assumption of channel state information (CSI) availability at cognitive users and have computed the ergodic and outage capacities closed-form expressions. Moreover, one important parameter, namely, the interference transmission ratio (ITR) which is the ratio of primary to secondary channel gain, has been defined based on which the cognitive user get the priority to transmit over other cognitive user. Further, OFDM based cognitive radio network is also exploited by researchers/scientists and the several authors have described different methods for the allocation of optimal power to the subcarriers of cognitive radio user because of the side-by-side coexistence of cognitive and primary users. Initially, the power loading method [41] has been developed for the OFDM cognitive radio network to allocate the optimal power to the subcarriers keeping interference constraint satisfied and using the location information of secondary subcarrier with respect to the primary users. The gradient decent approach [42], have been considered for power allocation to the subcarriers of OFDM cognitive radio network and have obtained minimum of the function to achieve capacity with the given interference temperature constraint. Furthermore, Zhang and Leung [43] have considered two constraints in OFDM cognitive radio network for optimum power allocation namely, the co-channel and adjacent channel interference constraint at the cost of high complexity $O(N \log N) + O(LM)$ (where N is the number of subcarriers of cognitive user and L is the number of primary user transmitter receiver pair) in comparison to the gradient based approach [42] considering only the adjacent channel interference and having complexity of $O(N)$. Moreover, Li [44] has used the geometrical programming approach for power allocation by considering the channel conditions, interference temperature, and required signal-to-interference noise ratio (SINR) in the centralized cognitive radio network. However, the author have considered only single licensed channel of a primary user, which has been shared by the multiple cognitive users simultaneously with CDMA technique and their main aim is the power saving by limiting the transmit power of the cognitive users.

In contrary, Chan and Zhang [45] have considered only single cognitive user and multiple primary users and have presented iteration minimum algorithm to obtain the optimal sensing time and transmit power for all the licensed channels to maximize utilization of all available channels. The complexity of iteration minimum method [45] is given as $O(Tf_s \log M + M)$ and has obtained the optimal solution in two iterations. The comparison of various power allocation methods in OFDM based cognitive radio networks are illustrated in Table 1. Since, the fairness is one of the important parameter considered for the network

performance, therefore, Wang et al. [46] have considered the fairness of the cognitive users in the OFDM based cognitive radio network and have proposed fast optimal power and simple power distribution algorithm with complexities of $O(L^2N)$ and $O(L + N)$, respectively. Moreover, the cognitive user's capacity optimization problem has been solved with interference, fairness and total power constraints taking into account [46]. Further, in [47], the joint rate and power optimization problem has been considered in max–min and proportional fairness scenario. The results have presented the proportional fairness, which has resulted higher throughput at the cost of some unfairness than the max–min fairness criteria [47]. Moreover, in [48], the authors have proposed an algorithm for spectrum allocation in both centralized and distributed approaches for optimizing the utilization and fairness, and the proposed algorithm have improved the throughput with reduced interference and complexity. In [49], SINR balancing problem has been considered which takes into account the fairness of cognitive users in the network under peak-transmit power and average interference power constraint. Further, the multiple constraint optimization problems in [49] have been divided into single constraint sub-problem to find the optimal solution. Moreover, to attempt the computation complexity problem in cognitive radio networks, Wang et al. [50] have proposed a fast algorithm for OFDM based cognitive radio network. Furthermore, in [51], a filter bank multicarrier (FBMC) scheme has been proposed instead of OFDM scheme for multicarrier communication in cognitive radio network, which have low complexity power allocation. However, the computation complexity of power and spectrum allocation problems in cognitive radio heterogeneous network has been reduced by the dynamic resource allocation method as discussed in [52].

Recently, a new power domain spectrum sharing method called the non-orthogonal multiple access (NOMA) [53] has been explored by the researchers/scientists. Various advantages of NOMA like higher throughput due to the wide bandwidth, exploitation of channel gain for optimal power allocation, has outperformed OFDM scheme [54] and is beneficial for the spectrum sharing in cognitive radio. All the users of NOMA utilize whole available bandwidth in comparison to the OFDMA, where the available bandwidth is divided into subcarriers which results enhanced throughput [55] and the power allocation to cognitive users considers the channel conditions, with more transmit power allocated to the user with good channel conditions in comparison to the user with more severe environment. Since the same frequency is utilized for all the users transmission in NOMA, therefore the receiver should have capability to decode its signal carefully and minimize the co-channel interference. Therefore, this system is somehow complex than that of OFDM in terms of receiver decoding scheme. The NOMA is an efficient scheme of spectrum sharing in cognitive radio because it avoids the competition among the cognitive users of getting the specific channels out of all the available channels and there is need of only power control according to the environment. The base station or central coordinator, controls the power allocation to different users, however for distributed environment NOMA concept is still open for research.

3.2 Game theory

The game theory in cognitive radio network is developed basically for the spectrum sharing through trading and fairness rules and main objective is to fulfill the cognitive network demand while maximizing revenue of the primary

Table 1 Comparison of power allocation methods in OFDM based cognitive radio networks

Power allocation method	Description	Complexity	No. of iterations
Gradient based approach [42]	Power allocation to the cognitive users in time varying channel with adaptive step size while transmitting in only unutilized licensed frequency band and considering adjacent channel interference. In this approach, multiple primary and cognitive users are considered	$O(N)$	3
Power loading scheme [43]	Consider both the co-channel and adjacent channel interference due to transmission by cognitive user in active and inactive licensed frequency bands, and the power allocation is performed in time varying channel	$O(N \log N) + O(LM)$	$L + 1$
Geometrical programming approach [44]	Considering coexistence of a primary user and multiple cognitive user in same frequency band and the power allocation is performed to the cognitive users with aim of power saving	Depends on the number of iterations.	Fixed
Iteration minimum algorithm [45]	Single cognitive user pair and multiple primary users are considered and cognitive users transmit only in unutilized licensed channels	$O(T_f \log N + N)$	2

network. Therefore, employing the game theory could effectively guarantee the fairness and rationality or the spectrum management among the cognitive network [56]. Further, in [56], the authors have also proposed the OODA (orient-observe-decide and act) method to share the primary network's spectrum among multiple heterogeneous cognitive networks with different QoS requirements and this method take into account the behavior modeling of the cognitive users. Moreover, there are two important scenarios of the spectrum sharing in heterogeneous cognitive network through the game theory, which are discussed as follows. (1) in which there are multiple cognitive networks than the primary networks and (2) in which there are multiple primary networks than the cognitive networks. However, only the harmonic utility functions of both the primary and secondary networks are defined.

Further, the authors in [57] have considered the varying bandwidth subcarriers of multicarrier communication network allocated to the cognitive user and the utility function with aim to maximize the data rate of cognitive users with constraint on resources such as power, spectrum and bandwidth are defined. The main contribution of this work lies on the definition of utility function which is based on the proportional fairness, harmonic mean fairness and maximum/minimum fairness with allocation problems. In addition to this, the channel conditions are considered for resource allocation among the competing cognitive users. In [57, 58], the authors have considered the same assumption on a node that it cannot transmit and receive on the same channel, simultaneously and have allocated the resources to competing users in the ad-hoc network, however [57] solves the convex optimization problem and in [58], the resource allocation by the connectivity graph coloring method is performed. The advantage of technique discussed in [57] over the connectivity graph is the less iteration requirement and throughput is significantly more in comparison to the iterative or connecting graph allocation. However, in both the schemes discussed in [57, 58], there are only one homogeneous primary user network which is utilized by the cognitive users without considering the heterogeneity of the primary user system. The authors in [59] have maximized the cognitive radio links capacities by using the incremental sub-gradient optimization approach for both with and without the fairness constraints and assumed that each cognitive radio user is half-duplex. The constant bandwidth of each OFDM subcarrier, which the cognitive users are utilizing, is considered and the occupied probability of subcarrier is incorporated into the resource allocation optimization problem. In the aforementioned references [56–59], the entire available spectrum from the spectrum pool is divided into orthogonal subcarriers for OFDM access scheme in order to minimize the interference and enhance the spectrum efficiency.

However, through the game theoretical spectrum sharing using OFDM access scheme in ad-hoc cognitive network, Niyato and Hossain [60] have performed the sharing of licensed spectrum using TDMA mode in the centralized cognitive network where all the available bandwidth is accessed by multiple cognitive users at different times. Moreover, this technique is simpler than the multicarrier communication but it result the throughput degradation in comparison to the multicarrier OFDM access scheme.

Niyato and Hossain [60] have emphasized on the various factors of spectrum trading between the primary and secondary users. The spectrum trading is the process which is needed after spectrum sensing to share the sensed idle channels. In the literature, three kinds of trading markets are defined viz monopoly, oligopoly and exchange market as discussed in detail in [61]. In [62], Nie and Comaniciu have investigated the design of channel sharing etiquette for the cognitive radio networks for both the cooperative and non-cooperative scenarios. For the spectrum sharing game in the cognitive radio network, the cognitive radios are the players and their strategies are the selection of new transmission parameters and new transmission frequencies, which influence their own performance as well as the performance of the neighboring players. In [62], the authors have also proposed two different utility functions: (1) for the selfish cognitive user that adapt to the channel for its transmission by causing little interference on that channel and (2) cooperative cognitive users which adapt to that channel which create little interference on that channel as well as on neighboring nodes/channels. Thus, the latter type of utility function requires users cooperation and hence much better than former, but at the cost of the increase in overhead. The cognitive user's utility function depends on the application. For example, in time-critical applications, a short delay or a minimum jitter are important criteria otherwise low bit-error-rate may be far more important than time criticality. These factors will be reflected in the user's utility functions, which they want to optimize [63]. The performances of different components of game theoretical framework for radio resource management, namely, the network-level bandwidth allocation, connection-level bandwidth allocation, capacity reservation, and admission control have been analyzed in detail in [64]. In addition to this, the method of spectrum sharing between various primary and secondary users based on the cost and amount of required bandwidth is explored in [65].

Furthermore, in [66, 67], the most common application of game theory that is the auction theory in cognitive radio spectrum sharing through interaction procedure between the cognitive users and primary users is presented. The optimality solution for obtaining the equilibrium in demand and supply of the auctioned spectrum is discussed in [68]. Moreover, it has been presented that the Nash equilibrium

[69] is used for non-cooperative game theory for allocating the spectrum to multiple cognitive users and Nash bargaining solution is for the cooperative game among cognitive and licensed users [68]. However, the static game spectrum sharing method employed for the spectrum allocation in [69] has deteriorated the efficiency of wireless network because of the inefficient Nash equilibrium outcomes due to the user's selfishness of achieving its own benefit discarding overall and fair spectrum sharing. Moreover, the spectrum sharing through cooperative game theory gives single objective function of all the cognitive users and provides optimal solution by considering each user's interest called linear proportional fairness method of spectrum sharing. In multiple cognitive users competing environment, the most common auction schemes are sequential auction [70] or Vickrey auctions [70], however the time definite assignment of spectrum [66] makes Vickrey auction more advantageous than that of the sequential auction for the cognitive users spectrum sharing.

Moreover, the single and double auction methods are also defined as the classification of auction methods [71]. In the single auction trading method there is one seller and many buyers, and the buyer which bid highest wins the item. However, in case the number of sellers and buyers grow large, double auction is efficient method for spectrum trading. In double auction [71, 72], the sellers/buyers submit their selling/buying prices to the auctioneer (spectrum broker) and the auctioneer decides to allocate the spectrum to the specific buyer at the price higher than that asked by specific seller to make profit for itself [73]. Moreover, the equilibrium in single and double auction methods have been discussed in detail in [74]. Further, in [75], the bidding procedure for the internet has been discussed with procedure constituting perfect Bayesian equilibrium. In [76], the authors have discussed the double auction in the primary and cognitive radio networks with the primary and cognitive users being the bidders of the available channels. The authors in [76] have considered that the broker will allocate the single channel to only one primary user network and to single/multiple cognitive user networks with primary network having higher priority than the cognitive user networks. Apart from this, the algorithms have also been proposed in [76] when there is single and multiple cognitive user networks on the single channel. Moreover, in [77], the double spectrum allocation problem has been designed for the spectrum allocation to primary and cognitive users, and in the proposed scheme the cognitive users request comes online. Also, the truthful mechanism for primary and cognitive users has been proposed that is called truthful online double auction (TODA) mechanism [77]. In addition to this, the benefited primary user network will get after trading the spectrum to cognitive network depends upon the amount of spectrum and the

amount of time the allocation is performed. However, the primary network should not deteriorate its own user's services in order to get more benefit. Therefore, Chang and Chen in [66] have considered the QoS of primary users through its blocking rate to ensure the proper allocation. The benefits of primary users, cognitive users, regulatory system and service provider have been considered and a super-frame structure of cognitive users for competing with each other is explored in [66]. In addition to this, the Vickrey auction scheme based on SINR and power is also discussed in [66] and the min-max fair SINR allocation is performed for cognitive game spectrum allocation. Instead of pricing and auction theory, the revenue based sharing is proposed in [78] in which the revenue shared by primary user network depends on the resources allocation among the primary and cognitive users. Moreover, the spectrum allocation to cognitive users by primary service provider is considered as NP hard problem as discussed in [79], in which the authors have proposed an auction algorithm that cannot be solved in polynomial time.

3.3 Multiple antennas

The concept of multiple antennas has also been exploited as a potential method for the spectrum sharing in the cognitive radio communication system due to the throughput enhancement and interference cancellation. A system model for the cognitive radio network, where multiple antennas are implemented at cognitive user transmitter is presented [80], which provides the significant enhancement in the channel capacity as compared to the single antenna at the cognitive user transmitter. In addition to this, it is also able to transmit on the same spectrum which the primary user is currently using due to the multiple antennas beam-forming. Moreover, the multiple antennas are used to allocate the transmit dimensions in space and hence provide the cognitive transmitter in a cognitive radio network more degrees of freedom in space in addition to the time and frequency to balance between maximizing its own transmit rate and minimizing the interference powers at the primary receivers. However, two algorithms: direct-channel singular value decomposition (D-SVD) and projected-channel SVD (P-SVD), which enhance the cognitive radio user capacity and avoid the interference at primary receiver by projecting null to the primary receiver through beam-forming, respectively, are proposed in [80]. Bakr et al. [81] have used the antenna weights to place nulls at the primary receivers whereas the secondary radio receivers use adaptive techniques to decode in the presence of interference from the primary users. To obtain the antenna weights, the channel estimation is performed through the feedback from the primary receivers and uses these estimates to compute the

appropriate antenna weight. The antenna weights are then adapted by the cognitive radio transmitter antennas to form the radiation pattern which nullify the interference at primary receiver and provide efficient communication to its respective cognitive radio receiver.

Furthermore, in [82, 83], the authors have discussed about the characteristic function and its application in computation of the channel capacity under the fading environment. In [84], the moment generating function (MGF) and characteristic function (CF) is used to compute the error rate as well as channel capacity. The fading channel capacity using the MGF approach in multiple antennas scenario with different correlation coefficient in the fading environments has been formulated in [85]. The authors in [86] have considered the cognitive radio spectrum sharing scenario without conventional constraint in the sharing environment that is on the cognitive users transmit power and primary user received interference power, and has interpreted that this results without degradation of the secondary or primary services due to the linear processing of the channel gains in multiple antennas spatial domain. The authors have also considered the imperfect channel state information (CSI) effect on the system performance, however the proposed method is not suitable for the cognitive users sharing full-duplex primary user spectrum. In addition to this, the authors of [87] have computed the single cognitive user system capacity by considering the interference constraint at primary receiver and hence need to limit its transmit power. Moreover, the multiple antennas are considered at both the secondary and primary users. However, the pre-whitening instead of post-whitening multi-antenna spectrum sharing technique is considered for the cognitive users which have reduced the amount of interference at primary receiver in comparison to the post-whitening scheme.

Further, the underlay multicast method of spectrum sharing in cognitive radio has been proposed in [88], using the multiple antennas only at cognitive access point, then broadcast the same information to all cognitive receivers with beam-steering and limit the side-lobe power to the primary receiver. However, the perfect CSI is needed in [88] otherwise coexistence of cognitive and primary users in the same spectrum might degrade both the primary and cognitive user performance. Sridharan and Vishwanath in [89] have derived the multiple-input-multiple-output (MIMO) cognitive channel (MCC) capacity with CSI knowledge at cognitive user. However, there is transmit power limit at both primary and secondary transmitter and MCC capacity is maximized by considering these two transmit power constraint at both the transmitter with the help of Lagrange's optimization. Since the cognitive user system does not want to change the primary user network and should not impose any restriction on the primary network, therefore

the primary user transmit power constraint [89] is not feasible solution to enhance the cognitive radio system performance. In [90], Adian, and Aghaeinia have jointly considered the transmission time and power allocation to the heterogeneous cognitive users in centralized and distributed cognitive network. In addition to this, the authors also have considered multiple antennas advantage with constraint of resource allocation fairness in heterogeneous cognitive user network. Recently, a new multiple antenna channel model called cognitive interference channel instead of classical interference channel has been considered in [91] where the cognitive transmitter is provided with the knowledge of the primary user data. This extra information at cognitive transmitter helps to know about the neighboring nodes.

3.4 Medium access control (MAC) protocol

Traditionally, in the spectrum sharing, the users get access to the channel through medium access control (MAC) protocol. The main difference in MAC protocol of traditional wireless communication and cognitive radio system is that the multiple channels have to be shared by the multiple cognitive users instead of the single channel sharing by the multiple users in conventional MAC protocols. In addition to this, the cognitive users have to differentiate between the primary user and cognitive user transmission, therefore it has to decide whether to stop transmission to protect the primary user or to retransmit in case of interference with other cognitive user. The available licensed channels for communication vary with time and location, due to this reason each cognitive user does not have fixed number of channels for transmission. All these functioning have to be incorporated into MAC protocol of the cognitive radio communication system. Since the cognitive user has intelligence capability and is able to switch among multiple channels and therefore, it is necessary in the cognitive radio MAC protocol spectrum sharing technique that the sensing and switching feature has to be incorporated. In addition to this, there may be multiple cognitive radio users trying to access the spectrum, therefore the cognitive radio network MAC protocol access should be coordinated to prevent multiple users colliding in overlapping portions of the spectrum. The cross-layer design and optimization methods [92, 93] for the cognitive radio have been provided to mitigate the layered protocol and structure limitations. The physical layer directly deals with the physical environment/channel that is followed by the MAC layer, which needs great attention for the design of communication system, and other various parameters of this layer are frame type, frame size, data rate, channel/time slot allocation, scheduling scheme, retransmission probability etc. All these parameters

of MAC layer are the part of MAC protocol and are responsible for the spectrum sensing and spectrum access decisions [94]. The major objectives of cognitive MAC protocol designs are:

1. To optimize the spectrum sensing and spectrum access decision,
2. To control the multiuser access in the multichannel network, and
3. To allocate the radio spectrum and schedule traffic transmission.

For DSA-based cognitive radio networks, MAC protocols which have been designed for traditional wireless networks need to be modified to include the spectrum sensing and spectrum access. The design of MAC protocols for cognitive radios are very challenging task due to the requirement for the coexistence of cognitive users with licensed users [94] and such a protocol needs to achieve the highest spectrum utilization by detecting all the spectrum opportunities accurately to access the spectrum so that the collision with the other cognitive users has to be minimized. However, based on the channel quality, the transmission parameters such as modulation and coding level can be adapted at the MAC level. Various ideas have been discussed to use some optimization model [94–96] for optimizing the spectrum sensing and spectrum access decision. In [94], Kim and Shin have discussed the mechanism for sensing period optimization and idle channel discovery delay reduction by the cognitive users. However, in [95], POMDP (partially observable Markov decision process) is employed for accessing the licensed channels by cognitive users. The MAC protocol has to select the best available channels to sense and based upon different channels sensing results, the cognitive radio user decides which channel has to access for the data transmission. This decision is based on the objective to maximize the transmission rate, and the constraints like the collision probability with a licensed user must be lower than the threshold. Considering the hardware constraints such as single radio, partial spectrum sensing and spectrum aggregation limit, the hardware constraint-MAC (HC-MAC) [96] has been proposed for an efficient spectrum sensing and access decision. The model is applicable for single or multiple channels/single or multiple users however it suffers from multichannel hidden terminal problem [96].

Further, the MAC protocol for multichannel and multiuser cognitive radio systems have been discussed in [97–102]. Moreover, the main objective of these systems is to perform negotiations among the cognitive users for spectrum access in the multichannel environments and to avoid collisions due to the simultaneous transmissions. In [97], the cognitive MAC (C-MAC) protocol is proposed for the distributed cognitive radio network in which there is no central entity like base station available for the coordination among

the cognitive radio terminal as presented in Fig. 3. In C-MAC, each available licensed channel is scheduled, which is divided into super-frames that consist of consecutive beacon and data transmission period. A rendezvous channel (RC) is assumed to be available throughout the network operation, which provides the synchronization and coordination among the cognitive users through non-overlapping beacon periods. There is backup channel also, which is detected during the sensing and is used to immediately provide choice of alternate spectrum band in case of appearance of the primary user. Each cognitive radio user periodically visits RC for sharing of load information of each band for: (1) synchronization, (2) to gather the information about primary and secondary user discovery, (3) to avoid the hidden node problem and, (4) to exchange the schedules for beacon periods so that beacons are not simultaneously sent over all the spectrum bands. Further, each cognitive terminal that wants to send data to its intended receiver will first send beacon signal during its designated beacon slot, coordinate with other users and once synchronized then can transmit over assigned channel. However, any spectrum change by the cognitive terminal that occurs in C-MAC must first be announced over the RC so that other cognitive user will also know about this change. Therefore, to set up an RC which is available throughout the cognitive network is a very important issue. However, this protocol has some technical issues such as to setup non-overlapping beacon, quiet periods without any central entity and RC availability [97]. In addition to this, the network synchronization must needed in C-MAC and needed for beacon control infrastructure makes it more complex. However, it is free from the hidden terminal problem as in the case with HC-MAC [96]. The cognitive radio enabled multi-channel (CREAM) MAC protocol has also been discussed in [98], which is free from hidden-terminal problem and network synchronization, however there is large communication overhead in this MAC protocol.

Further, the opportunistic spectrum access—MAC (OSA-MAC) for distributed cognitive radio network is proposed in [99] which is somehow similar to the architecture of IEEE 802.11 ad-hoc MAC protocol, however, the functioning is different than WLAN IEEE 802.11 MAC [103] as further explained. In the OSA-MAC, there is one dedicated control channel for cognitive users to exchange the control information, which is owned by the cognitive user service provider. The time of each channel is also divided into beacon intervals and all the cognitive users are synchronized with periodic beacon transmission. Each beacon interval consists of three phases namely, the channel selection phase, sensing phase and data transmission phase as shown in Fig. 4.

The cognitive user transmitter first sends ad-hoc traffic indication message (ATIM) over the control channel to its

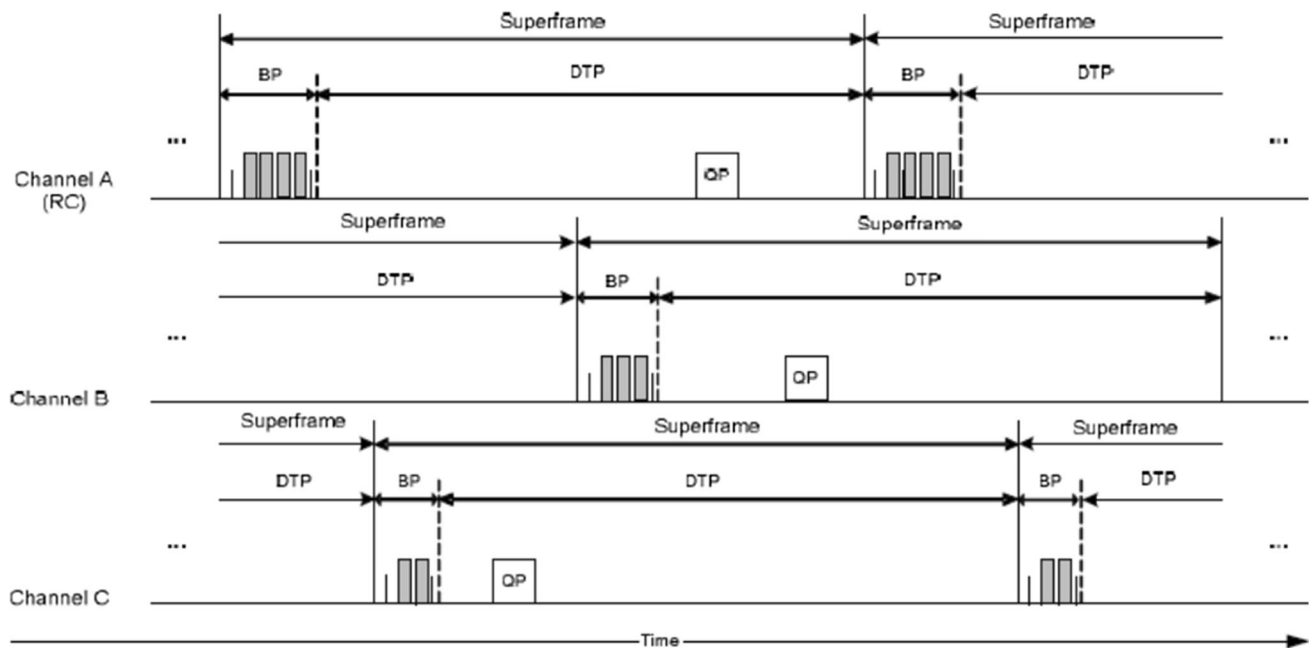

Fig. 3 The multichannel super-frame structures for C-MAC protocol in the distributed cognitive network as in [97]

receiver that contains the licensed idle channels list that it wants to use for data transmission. With the agreement on the selected channel, the cognitive receiver fed back ATIM-ACK (acknowledgment) to the transmitter over control channel, after that cognitive user switches to selected channel and start sensing it continuously during the sensing phase. However, if there is no primary user detected on the selected channel then data is transmitted during data transmission phase otherwise with the detection of primary user, the cognitive radio switches back to the control channel. The major limitation of OSA-MAC is large overhead before the actual data transmission as shown in Fig. 4, the data of cognitive user is transmitted after request-to-send (RTS) and clear-to-send (CTS) message exchange with respective receiver which is preceded by the amount of time at which the back-off timer has expired. There is bandwidth wastage also during ATIM window in OSA-MAC.

Further, an error adaptive MAC protocol [100] has been proposed with switching of error recovery and dual transmission modes according to the channel status of the cognitive radio network. Moreover, the additional channels detected during the sensing are utilized for error recovery in poor channel conditions and to increase the throughput for good channel states as shown in Fig. 5. However, this protocol makes the receiver systems more complex due to precise channel estimators and need more than one transceiver for utilizing large number of idle channels.

Recently, a self-scheduling multi-channel cognitive radio-MAC (SMC-MAC) protocol for the distributed cognitive network is shown in Fig. 6, has been proposed [104],

in which the cooperation among the cognitive users has minimized the sensing time and has enhanced the throughput. However, the technical issues needed to be handled in this protocol are the collisions of cognitive users in contention interval and the bandwidth wastage over the licensed channels during T_{ss} and T_{ct} period as shown in Fig. 6. In [105], the throughput of cognitive network is also enhanced with the use of back-off algorithm. The prioritized cognitive radio MAC (PCR-MAC) [106], cooperate and access spectrum sharing protocol [107], distributed sequential access MAC (DSA-MAC) [108] and cognitive adaptive MAC (CAMAC) [109] have been presented and various cognitive radio MAC protocols comparison are shown in Table 2. Further, the impact of selfish users on the MAC protocol fairness has been considered in [110] using Jain's fairness index [111].

There is significant scope for devising protocols that adapt the cognitive radio transmissions based on the type of the interferer. The newer performance metrics that capture the cognitive radio specific improvements should be devised and used for evaluating different MAC protocols. However, we believe that MAC protocol design for cognitive radio is an open area of research and will be of interest to both the industry and the academia as this technology matures in the next few years.

3.5 Throughput/capacity of cognitive radio

In general, the channel capacity is used as a basic tool for the performance analysis and design of new and more

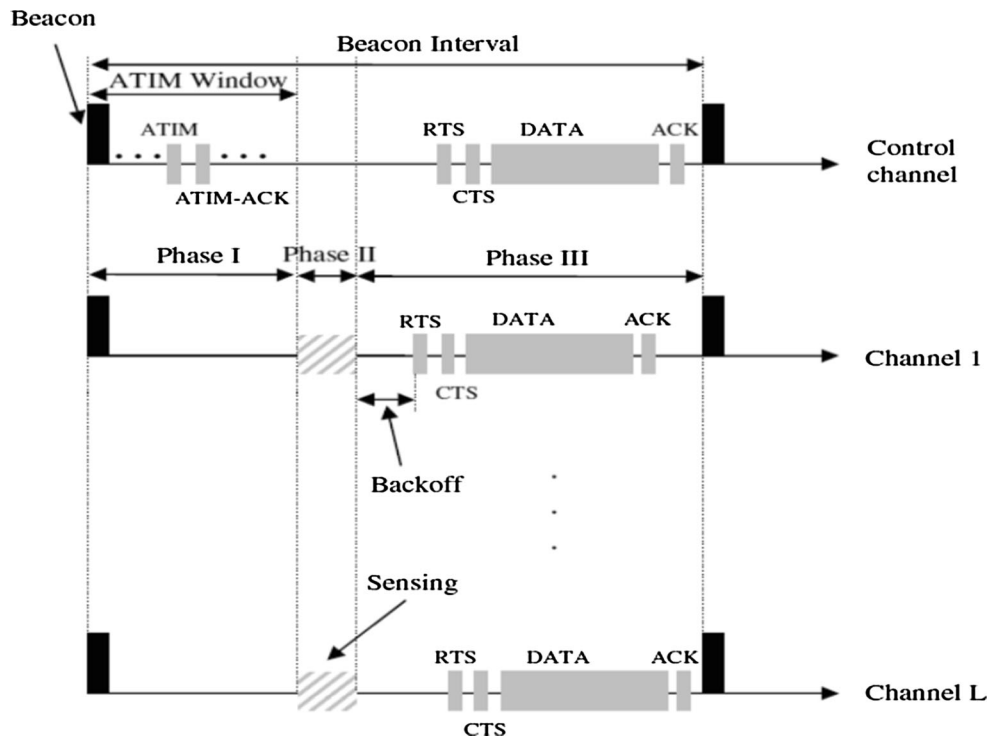

Fig. 4 Multichannel timing structure of OSA-MAC protocol for the distributed cognitive network [99]

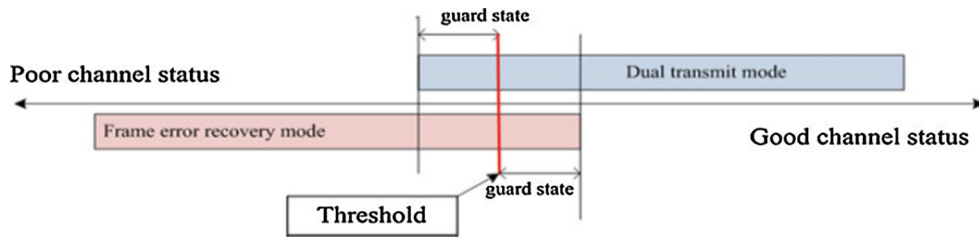

Fig. 5 The mode transition for error adaptive MAC protocol in the distributed cognitive radio network [99]

efficient techniques to improve the spectral efficiency of wireless communication systems. In the frame structure of cognitive radio user, longer sensing time accurately detect the presence of primary users and improves the sensing performance. However, for a fixed frame size (T), the longer sensing time (τ) shorten the allowable data transmission time ($T - \tau$) of the cognitive users as is clear from the below mentioned throughput equation of the cognitive user and the sensing-throughput tradeoff problem occurred [113].

$$\frac{T - \tau}{T} \left[P(H1)(1 - P_d) \log_2 \left(1 + \frac{SNR_s}{1 + SNR_p} \right) + P(H0)(1 - P_f) \log_2(1 + SNR_s) \right]$$

In the aforementioned equation, $P(H1)$ and $P(H0)$ denotes the probability of a channel being idle and busy, P_d and P_f are the detection and false alarm probability and SNR_s and SNR_p are received signal-to-noise ratio of secondary and primary users, respectively. This above mentioned MAC frame structure is shown in Fig. 7 reveals that the increased sensing time results in decreased data transmission time and vice versa. In addition to this, the authors have also obtained the optimal sensing slot duration in MAC frame, which maximizes the achievable throughput for cognitive users under the constraint that primary users are sufficiently protected from the cognitive radio user’s transmission. The duration of sensing time, significantly affects the throughput of cognitive users [113]. There is another technique to improve the spectrum sensing and

Fig. 6 The self-scheduling multi-channel MAC protocol [104]

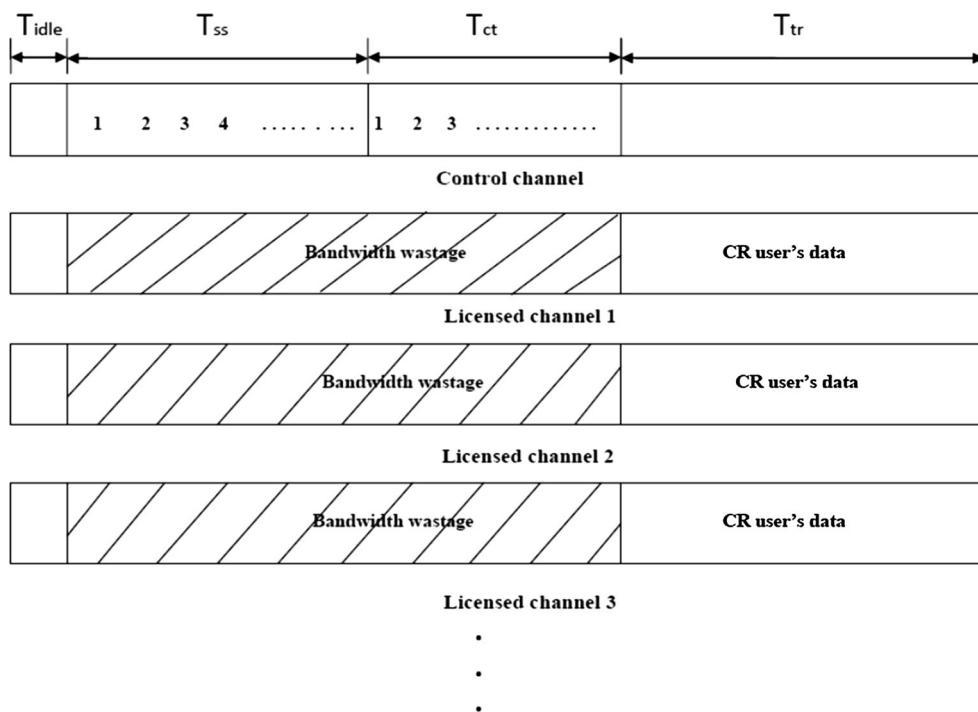

Table 2 Performance comparison of various CR-MAC protocols

Protocol	MAC technique	Spectrum access technique	No. of transceivers	Dedicated control channel	Synchronization needed	Hidden terminal problem
HC-MAC [96]	Contention based	Overlay	1	Yes	No	Yes
C-MAC [97]	Polling based	Interweave/OSA	1	Yes	Yes	No
CREAM-MAC [98]	Contention based	Interweave/OSA	1 with multiple sensors	Yes	No	No
OSA-MAC [99]	Contention based	Interweave/OSA	1	No	Yes	No
Error adaptive MAC [100]	Contention based	Interweave/OSA	More than one	No	No	Yes
SMC-MAC [104]	Contention based	Interweave/OSA	1	Yes	No	No
PCR-MAC [106]	Contention based	Interweave/OSA	2	Yes	No	No
Cooperate and access spectrum sharing protocol [107]	TDMA based	Overlay	1	No	Yes	Yes
DSA-MAC [108]	Polling based	Interweave/OSA	1	No	Yes	No
CAMAC [109]	Contention based	Interweave/OSA	1	Yes	No	No
MMAC-CR [112]	Contention based	Interweave/OSA	2	Yes	Yes	No

throughput performance that is the cooperative sensing, which is discussed in detail in [114]. There are various cooperative schemes to combine the sensing information from the cognitive users, such as the k-out-of-N fusion rule [115], soft-decision based fusion [116], and weighted data based fusion [117]. However, the joint optimization of sensing time and parameters of the cooperative sensing scheme are proposed in [115], which maximize the throughput of cognitive users. In [94, 118], the authors

have optimized the total frame time of cognitive users for known traffic pattern of licensed users. However, Hidden Markov Model (HMM) has been used to determine the traffic pattern of primary users in [119], in which Akbar and Tranter define that instead of jumping out from the frequency band after detecting the presence of signal from the licensed user, the cognitive radio network perform prediction on the usage behavior of frequency band of interests, and then decides to remain in the same frequency

Fig. 7 Frame structure of cognitive radio user resulting in sensing throughput tradeoff problem [113]

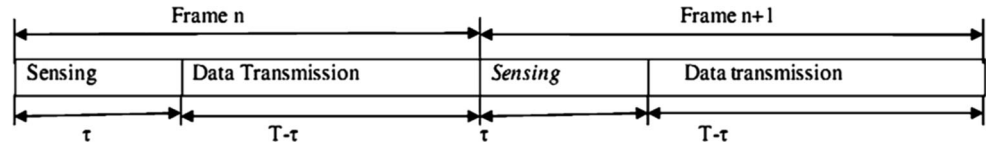

band or move to the another band. If the correct prediction is performed using HMM, the cognitive radio can leave the current frequency band before detecting any signal from the primary user, thus avoid the data loss and interference to and from the primary user network.

In [120], Stotas and Nallanathan have proposed a system model of cognitive radio in which the sensing and transmission is performed simultaneously in each frame to enhance the throughput and its frame structure as shown in Fig. 8. In addition to this, Stotas and Nallanathan [120] have also illustrated the throughput in both cases: one in which sensing and transmission is performed alternatively in each frame and other in which both are performed, simultaneously. However, the major limitation of [120] is that it utilizes the previous frame’s sensing results for making decision of data transmission in the current frame and it affect the cognitive and primary system performance in case primary user start transmitting in between the data transmission which is sensed but not utilized for current frame. However, this limitation is rectified in [121, 122] by applying sensing results of the same frame for data transmission in that frame with the help of flag bit. The new frame structure proposed in [121] is shown in Fig. 9 and this proposed frame structure is free from sensing-throughput tradeoff problem as given in below mentioned equation [121]:

$$P(H1)(1 - P_d) \log_2 \left(1 + \frac{SNR_s}{1 + SNR_p} \right) + P(H0) (1 - P_f) \log_2(1 + SNR_s)$$

The channel capacity of AWGN (Additive White Gaussian Noise) channel has been demonstrated by Shannon [123] and then the channel capacity in Rayleigh fading channel is given as $C = \int_0^\infty B \log_2(1 + \gamma) p(\gamma) d\gamma$ where γ is the received SNR in the Rayleigh fading channel and $p(\gamma)$ is the pdf of the Rayleigh channel [124]. The above defined

capacity is the average of the AWGN channel capacity. The results reveal that the average channel capacity in case of the fading environment is always less than that of AWGN channel and improvement in the capacity is achieved by using the diversity combining techniques. In [125], Ghaseem and Sousa have considered the fading channel in cognitive radio system and the capacity gain is provided to cognitive radio user when the channel between the primary receiver and cognitive transmitter is faded because the cognitive radio user may transmit with higher power in case of fading in contrast to AWGN channel without crossing the interference temperature limit at the primary receiver. Moreover, in [125] the channel capacity in cognitive radio network with average received and peak received power constraints has been considered and the capacity optimization problem for cognitive transmitter to cognitive receiver channel gain g_1 and secondary transmitter to primary receiver channel gain g_1 has been defined as [125]:

$$C = \max_{P(g_0, g_1 \geq 0)} \iint B \log_2 \left(1 + \frac{g_1 P(g_0, g_1)}{N_0 B} \right) x_1(g_1) f_0(g_0) dg_1 dg_0$$

Further, the simulation results discussed in [125] for the channel capacity of cognitive radio user has been explored for AWGN as well as for others fading environments. In [126], Goldsmith and Varaiya have discussed the capacity over fading channels by using the channel state information (CSI) for various transmitter and receiver adaptation policies. The mathematical expression for the channel capacity has been developed for known channel power gain at both the transmitter and receiver because of CSI. In [127], three adaptive transmission schemes namely optimal power and rate adaptation, constant power with optimal rate adaptation and channel inversion with fixed rate, are used in conjunction with the diversity combining over Rayleigh fading channel to compute the channel capacity. The channel capacity for the optimal rate and power adaptation (OPRA), optimal rate adaptation (ORA) and channel inversion with fixed rate

Fig. 8 The frame structure of the system eliminating sensing-throughput trade-off problem in the cognitive radio communication system [120]

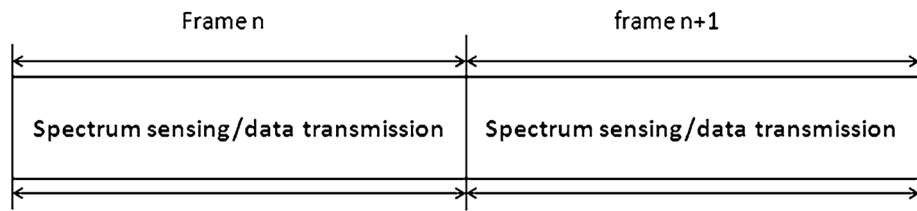
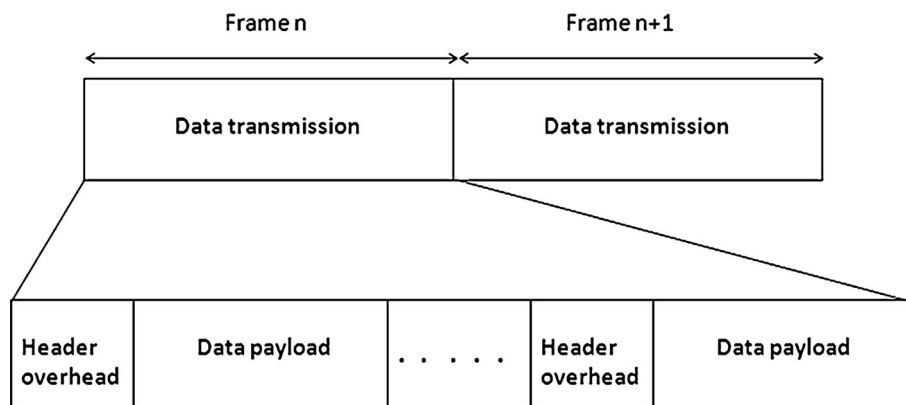

Fig. 9 The new frame structure of cognitive radio user [121]



(CIFR), with parameter γ_0 defined as the optimal cutoff carrier to noise ratio (CNR) value, are given as [127]:

$$\begin{aligned} C_{opra} &= B \int_{\gamma_0}^{\infty} \log_2 \left(\frac{\gamma}{\gamma_0} \right) p_{\gamma}(\gamma) d\gamma, \quad C_{ora} \\ &= B \int_0^{\infty} \log_2(\gamma) p_{\gamma}(\gamma) d\gamma, \quad C_{cifr} \\ &= B \log_2 \left(1 + \frac{1}{\int_0^{\infty} \frac{p_{\gamma}(\gamma)}{\gamma} d\gamma} \right) \end{aligned}$$

Further, in [128], the authors determine the single user channel capacity using the maximal ratio combining (MRC) diversity technique in correlated Rayleigh fading environment. To compute the channel capacity and adaptation in transmit power and rate, the pdf of channel gain is used. The channel capacity calculation in the fading environment using pdf is quite complex because there exist expressions including series. Then, the Generalized-K fading is considered in [129, 130], which combine both the small scale and large scale fading (shadowing) and derive the mathematical expression for channel capacity using the moment generating function (MGF). Further, the research on MGF and generalized fading are discussed in detail in [131, 132].

In [82, 83], the authors have discussed the characteristic function, which is used to compute the channel capacity under the fading environment. However, some of the limitations of CF-based and MGF-based approach for the computation of the channel capacity are discussed in [133] and also several methods to remove these limitations are explored. In [134], a general model for the cognitive radio channel has been proposed in which two cognitive transmitters can simultaneously use same frequency band to send their data to their respective receivers with the help of interference cancellation or mitigation techniques. In this scheme one transmitter sees the transmission of other transmitter as interference and tries to compensate it by using dirty-paper coding [33]. In [135], the authors have proposed the use of multiple antennas at both transmitter

and receiver for beam forming and transmit power is adapted to provide the throughput enhancement in case of the cellular system. However, the combine beam-forming effect of the transmitter and receiver increases the channel capacity and requires less transmit power as compared to the systems with only transmitter beam-forming or receiver beam-forming and explores the idea for further research.

The concept of multiple antennas is also used in [136] under some assumptions and the throughput enhancement has been compared with that of the single antenna user. Further, Jafar and Srinivasa [137] have discussed two aspects in cognitive radio: (1) distributed and (2) dynamic nature of environment. Since the cognitive transmitter and receiver are localized at different places, so it is natural that their sensing region will be different due to particular sensing range. Hence, the spectrum opportunity achieved by the cognitive transmitter may not be sensed by cognitive receiver and vice versa, which is called the distributed nature. It may also be possible that the primary user will switch own state very rapidly between the active and inactive state, known as dynamic nature of the primary users. In this case, it is very difficult to track this change and is very challenging task. However, the handshake between transmitter and receiver can be used to resolve this problem. Jafar and Srinivasa [137] have proposed two-switch models which capture both the distributed and dynamic nature of the primary users and the channel capacity for this model is computed. Further, Gastpar [138] proposes a spatial spectrum sharing constraint, which allows a network to access the same frequency band used by the other network, simultaneously under the condition that both the networks should be separated by a particular distance and interference power restriction should be put on the network and channel capacity has been computed for this scenario. This method can be adapted for the cognitive radio user by employing the cognitive user to spatially share the spectrum with primary user. In [139], the fading scenario and their effect on the rate and power selection for the cognitive radio user are illustrated. The

throughput of cognitive radio users has been computed by considering the interference, transmit power and quality-of-service constraints, which reveals the significant improvement in the sensing reliability and throughput of the cognitive user.

4 Conclusion and future directions

With the increasing importance of wireless communications, an adaptive and efficient utilization of the spectrum resources are required. The traditional technology-specific spectrum allocations are unable to accommodate the increasing demand uncertainty that characterizes the wireless communication today. The technology specific spectrum allocation will, therefore, inevitably lead to sub-optimal spectrum allocations. In this paper, we have presented an overview of the state-of-the-art of spectrum sharing/management in the cognitive radio communication system, which provides significantly high bandwidth to the mobile users via the heterogeneous wireless architecture and dynamic spectrum access techniques. Due to the fluctuating nature of available spectrum and diverse quality-of-service requirements for various applications, it imposes several challenges. The main challenges and future research directions have been presented, when emphasizing on the close-coupling of MAC protocol design with the other layers of protocol stack.

The potential challenges in deploying the dynamic spectrum access principles are those which significantly improving the spectrum utilization efficiency without losing the advantages associated with static spectrum allocation scheme. However, the first challenge is to develop the wireless devices and networks that can opportunistically operate in different frequency bands, and other challenges in the spectrum policy domain are to develop policies for the dynamic spectrum access which leads to an efficient spectrum use, protect the rights of license holders and maintain the quality-of-service. In addition to this, there are significant economic considerations such as the policies which must protect the interests of primary users those have made significant investments in the infrastructure. Moreover, it must be economically attractive to manufacturers and service providers to develop and deploy the equipment for opportunistic spectrum access by the cognitive users. The importance of spectrum trading depends on the technical advances made in the spectrum, such as power control, channel selection, and access behaviour. However, the balance between the supply and demand of the spectrum is very important parameter, which determines the future need of the spectrum trading. This balance is controlled by the technology as well as the ratio of license to license-exempt spectrum. Next, whatever the paths, the spectrum

technologies follow in future, the definition of spectrum usage rights is required as a framework for the user behaviour. Another important assumption in the earlier proposed work is that the cognitive users know the location and transmit power of the primary users so that the interference computation can be performed easily. However, such assumption may not always be valid in the cognitive radio networks. Therefore, to fully realize the potential of cognitive radio networks, there is a need to draw attention of the research community for developing advanced, context based and innovative methodologies/techniques and algorithms possibly inspired by multi-disciplinary research fields.

The algorithm and protocol for self-configuring cognitive radio, centralized/distributed cognitive radio network and for radio resource management is an emerging research area. Further, with all the spectrum decision and sharing techniques, the channel is considered as a spectrum unit hence the development of an algorithm is a crucial issue. In general, the common control channel facilitates many spectrum sharing functionalities, however a channel must be vacated when the primary user choose channel, then the implementation of a fixed common control channel is not feasible. Moreover, in the cognitive radio networks a channel common to all the users is highly dependent on topology and varies over time. Therefore, the solution of this issue is also very crucial in the cognitive radio communication systems. Further, the primary and secondary user's mobility has incorporated complexity in the cognitive radio network spectrum design. The presence or absence of licensed channel for a stationary or pedestrian cognitive user in a particular location will be ambiguous when the licensed user is moving very fast. In addition to this, the sensing decision of a particular channel in a scenario may not be accurate for the fast moving cognitive user because at the current location of cognitive user that channel availability status might be different and it would be recommended for fast cognitive users to do spectrum sensing frequently to minimize the false-alarm probability. In addition to this, the spectrum sharing in the cognitive radio network is highly dependent on the number of users in the system. If there are significantly more cognitive users, then the competition among cognitive users may decrease the cognitive radio network performance. Therefore, it is necessary to have highly scalable spectrum sharing cognitive radio system. Moreover, the energy efficient cognitive terminal is the need of future cognitive communication network and to incorporate the energy efficiency is a challenging task for the cognitive radio communication system designer.

The MAC protocol design should have some sleep and wake kind of procedure without service degradation of cognitive network. Since the user's terminal have limited battery life and the cognitive radio users sensing will also

consume energy in addition to its data transmission therefore, the cognitive radio spectrum sharing techniques should enhance the performance with minimum energy consumption. The cognitive radio communication systems work on the unutilized licensed channels and have lower priority than the licensed users, therefore the blocking probability of cognitive radio communication is significantly high which creates severe problem, particularly, for the real-time cognitive radio user's traffic. The sharing methods should be designed carefully in the cognitive radio networks which fulfill the quality-of-service requirements of the cognitive users. Furthermore, the security issues of cognitive radio network are one of the important tasks of the system designer and significantly more research work has not been performed towards the cognitive radio user's secure data reception and it needs potential attention in this field. The cognitive machine-to-machine communication and machine learning techniques are also an emerging issues and the spectrum sensing interface with the database for accurate detection of licensed users is an open research area in the cognitive radio network. Moreover, 5G communication using the cognitive radio has been recently proposed to performed on some higher frequencies e.g. on 28 GHz and 60 GHz [140], however it is challenging task to have a un-interruptive communication at such high frequency due to small coverage area and interference. Therefore, the practical implementation of cognitive radio in 5G is an open research area for researchers/scientists.

Acknowledgments The authors are sincerely thankful to the anonymous reviewers for critical comments and suggestions to improve the quality of the manuscript. The authors are also thankful to ISRO for project vide no. ISRO/RES/4/619/14-15.

References

1. NTIA. U.S. frequency allocations [online]. <http://www.ntia.doc.gov/files/ntia/publications/2003-allochrt.pdf>
2. Hoossain, E., Niyato, D., & Han, Z. (2009). *Dynamic spectrum access and management in cognitive radio networks*. New York: Cambridge University Press.
3. Zhao, Qing, & Sadler, B. M. (2007). A survey of dynamic spectrum access: Signal processing, networking, and regulatory policy. *IEEE Signal Processing Magazine*, 24(3), 79–89.
4. Santivanez, C., Ramanathan, R., Partridge, C., Krishnan, R., Condell, M., & Polit, S. (2006). Opportunistic spectrum access: Challenges, architecture, protocols. In *Proceedings of 2nd Annual International Workshop on Wireless Internet (WICON)*, New York, USA, pp. 1–9.
5. Mitola, J., III (2000). *Cognitive radio: An integrated agent architecture for software defined radio*. Ph.D. Thesis, Royal Institute of Technology (KTH) Sweden, May, 2000.
6. Jondral, F. K. (2005). Software-defined radio: Basics and evolution to cognitive radio. *EURASIP Journal on Wireless Communications and Networking*, 5(3), 275–283.
7. Ramacher, U. (2007). Software-defined radio prospects for multi-standard mobile phones. *IEEE Journal of Computer*, 40(10), 62–69.
8. Bagheri, R., Mirzaei, A., Heidari, M. E., Chehrazai, S., Lee, M., Mikhemar, M., et al. (2006). Software-defined radio receiver: Dream to reality. *IEEE Communications Magazine*, 44(8), 111–118.
9. Arslan, H., & Yarkan, S. (2007). *Cognitive radio, software defined radio, and adaptive wireless systems*. Netherlands: Springer.
10. Stevenson, C., Chouinard, G., Lei, Z. D., Hu, W. D., Shellhammer, S., & Caldwell, W. (2009). IEEE 802.22: The first cognitive radio wireless regional area network standard. *IEEE Communications Magazine*, 47(1), 130–138.
11. Phunchongharn, P., Hossain, E., Niyato, D., & Camorlinga, S. (2010). A cognitive radio system for e-health applications in a hospital environment. *IEEE Wireless Communications*, 17(1), 20–28.
12. Felice, M.-D., Chowdhury, K.-R., & Bononi, L. (2010). Analyzing the potential of cooperative cognitive radio technology on inter-vehicle communication. In *Proceedings of wireless days (WD) IFIP*, Venice, October 20–22, 2010, pp. 1–6.
13. Pawelczak, P., Prasad, R.-V., Xia, L., & Niemegeers, I.-G.-M.-M. (2005). Cognitive radio emergency networks—requirements and design. In *Proceedings of IEEE 1st international symposium on new frontiers in dynamic spectrum access networks (DySPAN)*, Baltimore, MD, USA, November 8–11, 2005, pp. 601–606.
14. Hinman, R.-D. (2006). Application of cognitive radio technology to legacy military waveforms in a JTRS (Joint Tactical Radio System) radio. In *Proceedings of IEEE Military Communications Conference (MILCOM)*, Washington, DC, October 23–25, 2006, pp. 1–5.
15. Akyildiz, I.-F., Lee, W.-Y., Vuran, M.-C., & Mohanty, S. (2006). NeXt generation/dynamic spectrum access/cognitive radio wireless networks: A survey. *Computer Networks*, 50(13), 2127–2159.
16. Wang, B., & Liu, K.-J.-R. (2011). Advances in cognitive radio networks: A survey. *IEEE Journal of Selected Topics in Signal Processing*, 5(1), 5–23.
17. Akyildiz, I.-F., Lee, W.-Y., Vuran, M.-C., & Mohanty, S. (2008). A survey on spectrum management in cognitive radio networks. *IEEE Communications Magazine*, 46(4), 40–48.
18. Zhang, G., Yang, K., Song, J., & Li, Y. (2013). Fair and efficient spectrum splitting for unlicensed secondary users in cooperative cognitive radio networks. *Wireless Personal Communications*, 71(1), 299–316.
19. Akyildiz, I.-F., Lo, B.-F., & Balakrishnan, R. (2011). Cooperative spectrum sensing in cognitive radio networks. *Physical Communication*, 4(1), 40–62.
20. Lee, C.-H., & Wolf, W. (2008). Energy efficient techniques for cooperative spectrum sensing in cognitive radios. In *Proceedings of IEEE consumer communications and networking conference (CCNC)*, Las Vegas, NV, January 10–12, pp. 968–972.
21. Sun, C., Zhang, W., & Letaief, K.-B. (2007). Cooperative spectrum sensing for cognitive radios under bandwidth constraints. In *Proceedings of IEEE wireless communications and networking conference (WCNC)*, Kowloon, March 11–15, 2007, pp. 1–5.
22. Sun, C., Zhang, W., & Letaief, K. B. (2007). Cluster-based cooperative spectrum sensing in cognitive radio systems. In: *Proceedings of IEEE international conference on communications (ICC' 07)*, Glasgow, June 24–28, pp. 2511–2515.
23. Flajolet, P., & Martin, G. N. (1985). Probabilistic counting algorithms for data base applications. *Journal of Computer and System Sciences*, 31(2), 182–209.

24. Quan, Z., Cui, S., & Sayed, A.-H. (2008). Optimal linear cooperation for spectrum sensing in cognitive radio networks. *IEEE Journal of Selected Topics in Signal Processing*, 2(1), 28–40.
25. Ma, J. & Li, Y. G. (2007). Soft combination and detection for cooperative spectrum sensing in cognitive radio networks. In *Proceedings of IEEE Global Telecommunications Conference (GLOBECOM)*, Washington, DC, November 26–30, pp. 3139–3143.
26. Song, M., Xin, C., Zhao, Y., & Cheng, X. (2012). Dynamic spectrum access: From cognitive radio to network radio. *IEEE Wireless Communications*, 19(1), 23–29.
27. Chang, C.-W., & Kuo, C.-C. (2010). An interweave cognitive radio system based on the hierarchical 2D-spread MC-DS-CDMA. In *Proceedings of IEEE vehicular technology conference fall (VTC 2010-Fall)*, Ottawa, Canada, September 6–9, 2010, pp. 1–5.
28. Soysal, A., Ulukus, S., & Clancy C. (2008). Channel estimation and adaptive M-QAM in cognitive radio links. In *IEEE proceedings of the international conference on communications (ICC' 08)*, Beijing, May 19–23, 2008, pp. 4043–4047.
29. Pursley, M.-B., & Royster, T. C. (2008). Low-complexity adaptive transmission for cognitive radios in dynamic spectrum access networks. *IEEE Journal on Selected Areas in Communications*, 26(1), 83–94.
30. Kim, D. I., Le, L. B., & Hossain, E. (2008). Joint rate and power allocation for cognitive radios in dynamic spectrum access environment. *IEEE Transactions on Wireless Communications*, 7(12), 5517–5527.
31. Srinivasa, S. & Jafar, S.-A. (2006). The throughput potential of cognitive radio: A theoretical perspective. In *Proceedings of the 40th Asilomar conference on signals, systems and computers (ACSSC' 06)*, Pacific Grove, CA, 29 Oct.–1 Nov. 2006, pp. 221–225.
32. Taki M., & Lahouti, F. (2009). Spectral efficiency optimized adaptive transmission for interfering cognitive radios. In *Proceedings of the IEEE international conference on communications workshops (ICC 2009)*, Dresden, June 2009, pp. 1–6.
33. Costa, M. (1983). Writing on dirty paper. *IEEE Transactions on Information Theory*, 29, 439–441.
34. Ghosh, C. (2009). *Innovative approaches to spectrum selection, sensing, and sharing in cognitive radio networks*. Ph. D. Thesis, University of Cincinnati, Ohio, April 2009.
35. Dashti, M., Azmi, P., Navaie, K., & Razavizadeh, S.-M. (2013). Ergodic sum rate maximization for underlay spectrum sharing with heterogeneous traffic. *Wireless Personal Communications*, 71(1), 586–610.
36. Kang, X., Liang, Y.-C., Garg, H.-K., & Zhang, L. (2009). Sensing based spectrum sharing in cognitive radio networks. *IEEE Transactions on Vehicular Technology*, 58(8), 4649–4654.
37. Xu, D., Feng, Z., & Zhang, P. (2013). On the impacts of channel estimation errors and feedback delay on the ergodic capacity for spectrum sharing cognitive radio. *Wireless Personal Communications*, 72(4), 1875–1887.
38. Pandit, Shweta, & Singh, G. (2015). Channel capacity in fading environment with CSI and interference power constraints for cognitive radio communication system. *Wireless Networks*, 21(4), 1275–1288.
39. Chen, Y., Yu, G., Zhang, Z., Chen, H., & Qiu, P. (2008). On cognitive radio networks with opportunistic power control strategies in fading channels. *IEEE Transactions on Wireless Communications*, 7, 2752–2761.
40. Kang, X. (2013). Optimal power allocation for fading cognitive multiple access channels: A two-user case. *IEEE Wireless Communications Letters*, 2(6), 683–686.
41. Bansal, G., Hossain, Md.- J., & Bhargava, V.- K. (2011). Adaptive power loading for OFDM based cognitive radio systems with statistical interference constraint. *IEEE Transactions on Wireless Communications*, 10(9), 2786–2791.
42. Pao, W.-C., & Chen, Y.-F. (2014). Adaptive gradient based method for adaptive power allocation in OFDM based cognitive radio networks. *IEEE Transactions of Vehicular Technology*, 63(2), 836–848.
43. Zhang, Y., & Leung, C. (2010). An efficient power loading scheme for OFDM based cognitive radio systems. *IEEE Transactions on Vehicular Technology*, 59(4), 1858–1864.
44. Li, D. (2011). Efficient power allocation for multi user cognitive radio networks. *Wireless Personal Communications*, 59(4), 589–597.
45. Chen, Z., & Zhang, X.-D. (2012). Power and time allocation between multiple channels in cognitive radio networks. *Wireless Personal Communications*, 64(4), 783–794.
46. Wang, S., Huang, F., & Wang, C. (2013). Adaptive proportional fairness resource allocation for OFDM-based cognitive radio networks. *Wireless Networks*, 19(3), 273–284.
47. Le, L.-B., & Hossain, E. (2008). Resource allocation for spectrum underlay in cognitive radio networks. *IEEE Transactions on Wireless Communications*, 7(12), 5306–5315.
48. Peng, C., Zheng, H., & Zhao, B.-Y. (2006). Utilization and fairness in spectrum assignment for opportunistic spectrum access. *Mobile Networks and Applications*, 11(4), 555–576.
49. Zhang, L., Liang, Y.-C., & Xin, Y. (2008). Joint beam forming and power allocation for multiple access channels in cognitive radio networks. *IEEE Journal on Selected Areas in Communications*, 26(1), 38–51.
50. Wang, S., Huang, F., & Zhou, Z.-H. (2011). Fast power allocation algorithm for cognitive radio networks. *IEEE Communications Letters*, 15(8), 845–847.
51. Shaat, M., & Bader, F. (2009) Low complexity power loading scheme in cognitive radio networks: FBMC capability. In *Proceedings of the IEEE international symposium on personal, indoor and mobile radio communications*, Tokyo, September 13–16, 2009, pp. 2597–2602.
52. Xie, R., Yu, F.-R., & Ji, H. (2012). Dynamic resource allocation for heterogeneous services in cognitive radio networks with imperfect channel sensing. *IEEE Transactions on Vehicular Technology*, 61(2), 770–780.
53. Benjebbour, A., Saito, Y., Kishiyama, Y., Li, A., Harada, A., & Nakamura, T. (2013) Concept and practical considerations of non-orthogonal multiple access (NOMA) for future radio access. In *Proceedings of international symposium on intelligent signal processing and communications systems (ISPACS)*, Naha, Japan, November 12–15, 2013, pp. 770–774.
54. Saito, Y., Benjebbour, A., Kishiyama, Y., & Nakamura, T. (2013) System-level performance evaluation of downlink non-orthogonal multiple access (NOMA). In *Proceedings of 24th IEEE international symposium on personal indoor and mobile radio communications (PIMRC)*, London, United Kingdom, September 8–11, 2013, pp. 611–615.
55. Saito, Y., Kishiyama, Y., Benjebbour, A., Nakamura, T., Li, A., & Higuchi, K. (2013). Non-orthogonal multiple access (NOMA) for cellular future radio access. In *Proceedings of 77th IEEE vehicular technology conference (VTC)*, Dresden, 2–5 June 2013, pp. 1–5.
56. Teng, Y., Yu, F.-R., Wei, Y., Wang, L., & Zhang, Y. (2012). Behavior modeling for spectrum sharing in wireless cognitive networks. *Wireless Networks*, 18(8), 99–947.
57. Guo, S., Dang, C., & Liao, X. (2011). Distributed algorithm for resource allocation of physical and transport layer in wireless cognitive ad-hoc networks. *Wireless Networks*, 17(2), 337–356.

58. Xi, Y., & Yeh, E.-M. (2007). Distributed algorithm for spectrum allocation, power control, routing and congestion control in wireless networks. In *Proceedings of the ACM international symposium on mobile ad hoc networking and computing canada*, September 9–14, pp. 180–189.
59. Guo, S., Dang, C., & Liao, X. (2011). Distributed resource allocation with fairness for cognitive radios in wireless mobile ad-hoc networks. *Wireless Networks*, 17(6), 1493–1512.
60. Niyato, D., & Hossain, E. (2008). Spectrum trading in cognitive radio networks: A market equilibrium based approach. *IEEE Wireless Communications*, 15(6), 71–80.
61. Yu, Q. (2013). A survey of cooperative games for cognitive radio networks. *Wireless Personal Communications*, 73(3), 949–966.
62. Nie, N., & Comaniciu, C. (2006). Adaptive channel allocation spectrum etiquette for cognitive radio networks. *Journal of Mobile Networks and Applications*, 11(6), 779–797.
63. Olafsson, S., Glover, B., & Nekovee, M. (2007). Future management of spectrum. *BT Technology Journal*, 25(2), 52–63.
64. Niyato, D., & Hossain, E. (2008). A non-cooperative game-theoretic framework for radio resource management in 4G heterogeneous wireless access networks. *IEEE Transactions on Mobile Computing*, 7(3), 332–345.
65. Pandit, S., & Singh, G. (2013). Spectrum sharing in cognitive radio using game theory. In *Proceedings of IEEE international advance computing conference (IACC-2013)*, India, February 22–23, pp. 1503–1506.
66. Chang, H.-B., & Chen, K.-C. (2010). Auction based spectrum management of cognitive radio networks. *IEEE Transactions on Vehicular Technology*, 59(4), 1923–1935.
67. Maharjan, S., Zhang, Y., & Gjessing, S. (2011). Economic approaches for cognitive radio networks: A survey. *Wireless Personal Communications*, 57(1), 33–51.
68. Ji, Z., & Liu, K.-J.-R. (2007). Dynamic spectrum sharing: A game theoretical overview. *IEEE Communications Magazine*, 45(5), 88–94.
69. Niyato, D., & Hossain, E. (2008). Competitive spectrum sharing in cognitive radio networks: A dynamic game approach. *IEEE Transactions on Wireless Communications*, 7(7), 2651–2660.
70. Aftab, O. (2002) *Economic mechanisms for efficient wireless coexistence*. MIT Tech. Rep. MIT-LCSTR-876. Cambridge, MA: Mass. Inst. Technol., Press.
71. Iosifidis, G., & Koutsopoulos, I. (2011). Challenges in auction theory driven spectrum management. *IEEE Communications Magazine*, 49(8), 128–135.
72. Teng, Y., Zhang, Y., Dai, C., Yang, F., & Song, M. (2011). Dynamic spectrum sharing through double auction mechanism in cognitive radio networks. In *Proceedings of IEEE wireless communications and networking conference (WCNC)*, Cancun, Quintana Roo, 28–31, pp. 90–95.
73. Deshmukh, K., Goldberg, A.-V., Hartline, J.-D., & Karlin, A.-R. (2002) Truthful and competitive double auctions. In *Proceedings of the 10th European symposium on algorithms (ESA '02)*, September 2002.
74. Jackson, M.-O., & Swinkels, J.-M. (2005). Existence of equilibrium in single and double private value auctions. *Econometrica*, 73(1), 93–139.
75. Peters, M., & Severinov, S. (2006). Internet auctions with many traders. *Journal of Economic Theory*, 130(1), 220–245.
76. Kasbekar, G.-S., & Sarkar, S. (2010). Spectrum auction framework for access allocation in cognitive radio networks. *IEEE/ACM Transactions on Networking*, 18(6), 1841–1854.
77. Wang, S.-G., Xu, P., Xu, X.-H., Tang, S., Li, X.-Y., & Liu, X. (2010). TODA: Truthful online double auction for spectrum allocation in wireless networks. In *Proceedings of IEEE symposium on new frontiers in dynamic spectrum*, 6–9 April 2010, Singapore, pp. 1–10.
78. Wu, Y., Zhu, Q., Huang, J., & Tsang, D.-H.-K. (2014). Revenue sharing based resource allocation for dynamic spectrum access networks. *IEEE Journal on Selected Areas in Communications*, 32(11), 2280–2296.
79. Li, C., Liu, Z., Geng, X., Dong, M., Yang, F., Gan, X., et al. (2014). Two dimension spectrum allocation for cognitive radio networks. *IEEE Transactions on Wireless Communications*, 13(3), 1410–1423.
80. Zhang, R., & Liang, Y.-C. (2008). Exploiting multi-antennas for opportunistic spectrum sharing in cognitive radio networks. *IEEE Journal of Selected Topics in Signal Processing*, 2(1), 88–102.
81. Bakr, O., Johnson, M., Mudumbai, R., & Ramchandran, K. (2009). Multi-antenna interference cancellation techniques for cognitive radio applications. In *Proceedings of IEEE wireless communications and networking conference (WCNC 2009)*, Budapest, 5–8 April, 1–6.
82. Chiani, M., Win, M.-Z., & Zanella, A. (2003). On the capacity of spatially correlated MIMO Rayleigh-fading channels. *IEEE Transactions on Information Theory*, 49(49), 2363–2371.
83. Jeong, W.-C., Chung, J.-M., & Liu, D. (2008). Characteristic-function-based analysis of MIMO systems applying macroscopic selection diversity in mobile communications. *Journal of Electronics and Telecommunications Research Institute*, 30(3), 335–364.
84. Ihan, H.-I., Altunbas, I., & Uysal, M. (2011). Moment generating function-based performance evaluation of amplify-and-forward relaying in N^* Nakagami fading channels. *IET Communications*, 5(3), 253–263.
85. Wang, Y., & Yue, D.-W. (2009). Capacity of MIMO Rayleigh fading channels in the presence of interference and receive correlation. *IEEE Transactions on Vehicular Technology*, 58(8), 4398–4405.
86. Bixio, L., Oliveri, G., Ottonello, M., & Raffetto, M. (2010). Cognitive radios with multiple antennas exploiting spatial opportunities. *IEEE Transactions on Signal Processing*, 58(8), 4453–4459.
87. Kang, M.-S., Jung, B.-C., Sung, D.-K., & Choi, W. (2008). A pre-whitening scheme in a MIMO-based spectrum-sharing environment. *IEEE Communications Letters*, 12(11), 831–833.
88. Phan, K.-T., Vorobyov, S.-A., Sidiropoulos, N.-D., & Tellambura, C. (2009). Spectrum sharing in wireless networks via QoS-aware secondary multicast beam forming. *IEEE Transactions on Signal Processing*, 57(6), 2323–2335.
89. Sridharan, S., & Vishwanath, S. (2008). On the capacity of a class of MIMO cognitive radios. *IEEE Journal of Selected Topics in Signal Processing*, 2(1), 103–117.
90. Adian, M.-G., & Aghaeinia, H. (2014). Optimal resource allocation in heterogeneous MIMO cognitive radio networks. *Wireless Personal Communications*, 76(1), 23–39.
91. Rini, S., & Goldsmith, A. (2014). On the capacity of the multi-antenna Gaussian cognitive interference channel. *IEEE Journal on Selected Areas in Communications*, 32(11), 2252–2267.
92. Maharshi, A., Tong, L., & Swami, A. (2003). Cross-layer designs of multichannel reservation MAC under Rayleigh fading. *IEEE Transactions on Signal Processing*, 51(8), 2054–2067.
93. Wang, J., Li, L., Low, S. H., & Doyle, J.-C. (2005). Cross-layer optimization in TCP/IP networks. *IEEE/ACM Transactions on Networking*, 13(3), 582–595.
94. Kim, H., & Shin, K. G. (2008). Efficient discovery of spectrum opportunities with MAC-layer sensing in cognitive radio networks. *IEEE Transactions on Mobile Computing*, 7(5), 533–545.

95. Zhao, Q., Tong, L., Swami, A., & Chen, Y. (2007). Decentralized cognitive MAC for opportunistic spectrum access in ad hoc networks: A POMDP framework. *IEEE Journal on Selected Areas in Communications*, 25(3), 589–600.
96. Jia, J., Zhang, Q., & Shen, X. (2008). HC-MAC: A hardware-constrained cognitive MAC for efficient spectrum management. *IEEE Journal on Selected Areas in Communications*, 26(1), 106–117.
97. Cordeiro, C., & Challapali, K. (2007). C-MAC: A cognitive MAC protocol for multi-channel wireless networks. In *Proceedings of 2nd IEEE international symposium on new frontiers in dynamic spectrum access networks (DySPAN)*, Dublin, 17–20 April 2007, pp. 147–157.
98. Su, H., & Zhang, X. (2008). CREAM-MAC: An efficient cognitive radio-enabled multi-channel MAC protocol for wireless networks. In *Proceedings of IEEE international symposium on world of wireless, mobile and multimedia networks (WoWMoM)*, June 2008, Newport Beach, CA, pp. 1–8.
99. Le, L. B. & Hossain, E. (2008) OSA-MAC: A multi-channel MAC protocol for opportunistic spectrum access in cognitive radio networks. In *Proceedings of IEEE wireless communications and networking conference (WCNC)*, 31 March–3 April 2008, Las Vegas, NV, pp. 1426–1430.
100. Lee, S. -H., Lee, B. -J., & Rhee, S. -H. (2012). Efficient utilization of available channels in dynamic spectrum access networks. *Wireless Personal Communications*, 67(1). <http://link.springer.com/journal/11277/67/1/page/1>, 95–104 August, 2012.
101. Papadimitratos, P., Sankaranarayanan, S., & Mishra, A. (2005). A bandwidth sharing approach to improve licensed spectrum utilization. *IEEE Communications Magazine*, 43(12), S10–S14.
102. Sabharwal, A., Khoshnevis, A., & Knightly, E. (2007). Opportunistic spectral usage: Bounds and a multi-band CSMA/CA protocol. *IEEE/ACM Transactions on Networking*, 15(3), 533–545.
103. IEEE 802.11. Wireless LAN medium access control (MAC) and physical layer (PHY) Specifications, *IEEE*, June 2007.
104. Lim, S., & Lee, T.-J. (2011). A self-scheduling multi-channel cognitive radio MAC protocol based on cooperative communications. *IEICE Transactions on Communications*, E94-B(6), 1657–1668.
105. Pandit, Shweta, & Singh, G. (2015). Backoff algorithm in cognitive radio MAC-protocol for throughput enhancement. *IEEE Transactions on Vehicular Technology*, 64(5), 1991–2000.
106. Hossain, R., Rijul, R.-H., Razzaque, M.-A., & Sarkar, A.-M.-J. (2014). Prioritized medium access control in cognitive radio ad hoc networks: Protocol and analysis. *Wireless Personal Communications*, 79(3), 2383–2408.
107. Xie, P., Li, L., Zhu, J., Zheng, R., & Zhang, M. (2015). A cooperation and access spectrum sharing protocol with cooperative interference management. *Wireless Personal Communications*, 81(3), 997–1015.
108. Lee, K., & Kim, C. (2013). Distributed sequential access MAC protocol for single hop wireless networks. *Wireless Personal Communications*, 72(4), 2177–2184.
109. Shah, G., & Akan, O. (2014). Cognitive adaptive medium access control in cognitive radio sensor networks. *IEEE Transactions on Vehicular Technology*, 64(2), 757–767.
110. Bian, K. & Park, J.-M. (2006). MAC-layer misbehaviors in multi-hop cognitive radio networks. In *Proceedings of the US-Korea conference on science, technology and entrepreneurship (UKC2006)*, 2006, pp. 1–8.
111. Jain, R. (1991). *The art of computer system performance analysis: Techniques for experimental design, measurement, simulation and modeling*. New Delhi: Wiley.
112. Timmers, M., Pollin, S., Dejonghe, A., Perre, L.-V., & Catthoor, F. (2010). A distributed multichannel MAC protocol for multihop cognitive radio networks. *IEEE Transactions on Vehicular Technology*, 59(1), 446–459.
113. Liang, Y.-C., Zeng, Y., Peh, E.-C.-Y., & Hoang, A.-T. (2008). Sensing-throughput trade-off for cognitive radio networks. *IEEE Transactions on Wireless Communications*, 7(4), 1326–1337.
114. Fan, R., & Jiang, H. (2010). Optimal multi-channel cooperative sensing in cognitive radio networks. *IEEE Transactions on Wireless Communications*, 9(3), 1128–1138.
115. Chu, E., Liang, Y.-C., Guan, Y.-L., & Zeng, Y. (2009). Optimization of cooperative sensing in cognitive radio networks: A sensing-throughput tradeoff view. *IEEE Transactions on Vehicular Technology*, 58(9), 5294–5299.
116. Chair, Z., & Varshney, P. K. (1986). Optimal data fusion in multiple sensor detection systems. *IEEE Transactions on Aerospace and Electronic Systems*, 22(1), 98–101.
117. Quan, Z., Cui, S., & Sayed, A. H. (2008). Optimal linear cooperation for spectrum sensing in cognitive radio networks. *IEEE Journal of Selected Topics in Signal Processing*, 2(1), 28–40.
118. Lee, W.-Y., & Akyildiz, I.-F. (2008). Optimal spectrum sensing framework for cognitive radio networks. *IEEE Transactions on Wireless Communications*, 7(10), 3845–3857.
119. Akbar, I.-A. & Tranter, W.-H. (2007) Dynamic spectrum allocation in cognitive radio using hidden markov models: Poisson distributed case. In *Proceedings of IEEE SoutheastCon*, Richmond, VA, 22–25 March 2007, pp. 196–201.
120. Stotas, S. & Nallanathan, A. (2010). On the throughput maximization of spectrum sharing cognitive radio networks. In *Proceedings of IEEE global telecommunications conference (GLOBECOM 2010)*, Miami, FL, December 6–10, pp. 1–5.
121. Pandit, S., & Singh, G. (2014). Throughput maximization with reduced data loss rate in cognitive radio network. *Telecommunication Systems*, 57(2), 209–215.
122. Pandit, S. (2012) *Spectrum sharing in cognitive radio system for throughput optimization and interference reduction*. M. Tech. Thesis, Jaypee University of Information Technology, India, May 2012.
123. Shannon, C. (1958). Channels with side information at the transmitter. *IBM Journal of Research and Development*, 2(2), 289–293.
124. Lee, W. (1990). Estimate of channel capacity in Rayleigh fading environment. *IEEE Transactions on Vehicular Technology*, 39(3), 187–189.
125. Ghasem, A., & Sousa, E.-S. (2007). Fundamental limits of spectrum-sharing in fading environments. *IEEE Transactions on Wireless Communications*, 6(2), 649–658.
126. Goldsmith, A.-J., & Varaiya, P.-P. (1997). Capacity of fading channels with channel side information. *IEEE Transactions on Information Theory*, 43(6), 1986–1992.
127. Alouini, M.-S., & Goldsmith, A.-J. (1999). Capacity of Rayleigh fading channels under different adaptive transmission and diversity-combining techniques. *IEEE Transactions on Vehicular Technology*, 48(4), 1165–1181.
128. Mallik, R. K., Win, M. Z., Shao, J. W., Alouini, M.-S., & Goldsmith, A. J. (2004). Channel capacity of adaptive transmission with maximal ratio combining in correlated Rayleigh fading. *IEEE Transactions on Wireless Communications*, 3(4), 1124–1133.
129. Peppas, K., Lazarakis, F., Alexandridis, A., & Dangakis, K. (2010). Cascaded generalized-K fading channel. *IET Communications*, 4(1), 116–124.
130. Bithas, P.-S., Mathiopoulos, P.-T., & Kotsopoulos, S.-A. (2007). Diversity reception over Generalized-K (\mathbf{K}_G) fading channels. *IEEE Transactions on Wireless Communications*, 6(12), 4238–4243.

131. Dwivedi, Vivek K., & Singh, G. (2012). A novel Marginal MGF based analysis of the channel capacity over correlated Nakagami- m fading with maximal-ratio combining diversity. *Progress Electromagnetic Research B*, 41, 333–356.
132. Dwivedi, Vivek K., & Singh, G. (2012). A novel MGF based analysis of channel capacity of generalized-K fading with maximal ratio combining diversity. *Progress Electromagnetic Research C*, 26, 153–165.
133. Renzo, M.-D., Graziosi, F., & Santucci, F. (2010). Channel capacity over generalized fading channels: A novel MGF-based approach for performance analysis and design of wireless communication systems. *IEEE Transactions on Vehicular Technology*, 59(1), 127–149.
134. Devroye, N., Mitran, P., & Tarokh, V. (2006). Achievable rates in cognitive radio channels. *IEEE Transactions on Information Theory*, 52(5), 1813–1827.
135. Chang, J.-H., Tassiulas, L., & Farrokhi, F.-R. (2002). Joint transmitter receiver diversity for efficient space division multi-access. *IEEE Transactions Wireless Communications*, 1(1), 16–27.
136. Spencer, Q.-H., Swindlehurst, A.-L., & Haardt, M. (2004). Zero-forcing methods for downlink spatial multiplexing in multiuser MIMO channels. *IEEE Transactions on Signal Processing*, 52(2), 461–471.
137. Jafar, S.-A., & Srinivasa, S. (2007). Capacity limits of cognitive radio with distributed and dynamic spectral activity. *IEEE Journal Selected Areas in Communications*, 25(3), 529–537.
138. Gastpar, M. (2007). On capacity under receive and spatial spectrum-sharing constraints. *IEEE Transactions on Information Theory*, 53(2), 471–487.
139. Akin, S. (2011) *Wireless communications and cognitive radio transmissions under quality of service constraints and channel uncertainty*. Ph. D. Thesis, University of Nebraska.
140. Rappaport, T. S., Shu Sun, R., Mayzus, H., Zhao, Y., Azar, K., Wang, G. N., et al. (2013). Millimeter wave mobile communications for 5G cellular: It will work! *IEEE Access*, 1, 335–349.



Shweta Pandit has received B. Tech. (Honours) degree from Himachal Pradesh University, Shimla, India in 2010 and M. Tech. and Ph.D. degree in Electronics and Communication Engineering from the Department of Electronics and Communication Engineering, Jaypee University of Information Technology, Wakanaghat, Solan, India in 2012 and 2015, respectively. Currently, she is Assistant Professor with the Department of Electronics and

Communication Engineering, Wakanaghat, Solan, India. Her area of

research interests is next generation communication system, cognitive radio, wireless network, and capacity enhancement and interference reduction in wireless channel.



Professor G. Singh received Ph.D. degree in Electronics Engineering from the Indian Institute of Technology, Banaras Hindu University, Varanasi, India, in 2000. He was associated with Central Electronics Engineering Research Institute, Pilani, and Institute for Plasma Research, Gandhinagar, India, respectively, where he was Research Scientist. He had also worked as an Assistant Professor at Electronics and Communication Engineering

Department, Nirma University of Science and Technology, Ahmedabad, India. He was a Visiting Researcher at the Seoul National University, Seoul, South Korea. At present, he is Professor with the Department of Electronics and Communication Engineering, Jaypee University of Information Technology, Wakanaghat, Solan, India. He is an author/co-author of more than 185 scientific papers of the refereed Journal and International Conferences. His research and teaching interests include RF/Microwave Engineering, Millimeter/THz Wave Antennas and its Applications in Communication and Imaging, Next Generation Communication Systems (OFDM and Cognitive Radio), and Nanophotonics. He has more than 15 years of teaching and research experience in the area of Electromagnetic/Microwave Engineering, Wireless Communication and Nanophotonics. He has supervised various Ph. D. and M. Tech. theses. He has worked as a reviewer for several reputed Journals and Conferences. He is author of two books “Terahertz Planar Antennas for Next Generation Communication” and “MOSFET Technologies for Double-Pole Four-Throw Radio-Frequency Switch” published by Springer.