

The Monge–Kantorovich Metric on Multimeasures and Self–Similar Multimeasures

D. La Torre · F. Mendivil

Received: 6 June 2014 / Accepted: 21 November 2014 / Published online: 3 December 2014
© Springer Science+Business Media Dordrecht 2014

Abstract For a metric space (\mathbb{X}, d) the classical Monge–Kantorovich metric d_M gives a distance between two probability measures on \mathbb{X} which is tied to the underlying distance d on \mathbb{X} in an essential way. In this paper, we extend the Monge–Kantorovich metric to signed measures and set-valued measures (multimeasures) and, in each case, prove completeness of a suitable space of these measures. Using this extension as a framework, we construct self-similar multimeasures by using an IFS-type Markov operator.

Keywords Monge–Kantorovich metric · Set-valued measures · Spaces of measures · Iterated function systems · Zonotope

Mathematics Subject Classifications (2010) 28B20 · 28A33 · 60B10 · 28A80

1 Introduction

There are many different metrics one can place on the set of probability measures which yield the topology of weak convergence [23]. Such metrics have obvious applications to convergence rates in probabilistic limit theorems and also to measuring “closeness” in probabilistic approximations. The Monge–Kantorovich metric is a particularly nice example of such a metric. This metric was introduced for compact metric spaces in [18, 19]. The Monge–Kantorovich metric results from the dual of Kantorovich’s reformulation

D. La Torre
Department of Economics Management and Quantitative Methods, University of Milan, Milan, Italy

D. La Torre
Department of Applied Mathematics and Sciences, Khalifa University, Abu Dhabi, UAE
e-mail: davide.latorre@unimi.it; davide.latorre@kustar.ac.ae

F. Mendivil (✉)
Department of Mathematics and Statistics, Acadia University, Nova Scotia Wolfville, Canada
e-mail: franklin.mendivil@acadiau.ca

of Monge’s problem of the transportation of mass. As such, the distance between two probability distributions is linked to the underlying metric on the metric space.

For a metric space (\mathbb{X}, d) , let

$$\text{Lip}_1(\mathbb{X}) = \{f : \mathbb{X} \rightarrow \mathbb{R} \mid |f(x) - f(y)| \leq d(x, y) \forall x, y \in \mathbb{X}\}.$$

The Monge-Kantorovich distance between two Borel probability measures μ, ν on \mathbb{X} is given as

$$d_M(\mu, \nu) = \sup \left\{ \int_{\mathbb{X}} f(x) d(\mu - \nu)(x) : f \in \text{Lip}_1(\mathbb{X}) \right\}. \tag{1}$$

From this we see that d_M is defined via a duality between measures and Lipschitz functions; one of Kantorovich’s many great achievements was recognizing and proving this duality. The “geometric” link between d_M and d is most easily seen when μ and ν are point masses. If $\mathbb{X} = [0, 1]$ and $\mu = \delta_x$ and $\nu = \delta_y$ (point masses at x and y respectively), then it is easy to see that $d_M(\mu, \nu) = |x - y|$. This explicit reliance of $d_M(\mu, \nu)$ on the underlying metric d on \mathbb{X} is one of the most useful features of the Monge-Kantorovich metric in applications [27].

Our purpose is to construct a version of the Monge-Kantorovich metric on set-valued measures (or multimeasures) and to prove completeness of an appropriately defined space of multimeasures. In order to do this, we first need a version of the Monge-Kantorovich metric on signed measures. We then prove completeness of a suitable subspace of signed measures and multimeasures under the Monge-Kantorovich metric. As a simple application of our results, we construct an Iterated Function System (IFS) operator on multimeasures. This gives a construction of self-similar multimeasures whose values are nonempty compact and convex subsets of \mathbb{R}^m .

Multimeasures ϕ can be considered as a generalization of the classical notion of a signed measure or a vector-valued measure μ by setting $\phi(E) = \{\mu(E)\}$. Vector-valued measures in the IFS setting have been studied in [3, 10, 21]. Set-valued measures were first introduced for the needs of mathematical economics. In [8, 20, 29] they were used to study equilibria in exchange economies in which coalitions correspond to measurable sets and are the primary economic units. Furthermore, the study of set-valued measures has been developed extensively because of its applications in other fields such as optimization and optimal control [13, 25, 26].

In Section 2 we give some background on multimeasures with compact and convex values. Section 3 contains the major results of this paper, the construction of the Monge-Kantorovich metric on spaces of signed and set-valued measures and the proofs of the completeness of these spaces. For simplicity of exposition we restrict our constructions to compact metric spaces, though it is possible to extend this to locally compact Polish spaces. Finally, in Section 4 we define the natural IFS operators on multimeasures, derive contractivity conditions, and provide some examples.

2 Preliminary Definitions and Notations

Consider a nonempty set \mathbb{X} and a σ -algebra \mathcal{B} on \mathbb{X} . A *set-valued measure* or *multimeasure* on $(\mathbb{X}, \mathcal{B})$ is a function

$$\phi : \mathcal{B} \rightarrow \{K \subset \mathbb{R}^m : K \neq \emptyset\},$$

which for any finite or countable sequence of disjoint sets $A_i \in \mathcal{B}$ satisfies

$$\phi \left(\bigcup_{i \geq 1} A_i \right) = \sum_{i \geq 1} \phi(A_i).$$

The right side is defined to be the infinite Minkowski sum given by

$$\sum_i K_i = \left\{ \sum_i k_i : k_i \in K_i, \sum_i |k_i| < +\infty \right\}.$$

A finite vector-valued measure is a multimeasure after identifying vectors with singleton sets, and in particular a real non-negative measure is a multimeasure iff all sets have finite measure.

For $A \subset \mathbb{R}^m$ and $q \in \mathbb{R}^m$ the *support function* of the set A in the direction q is defined by

$$\text{spt}(q, A) = \sup\{q \cdot x : x \in A\}.$$

For a multimeasure ϕ let

$$\phi^q(B) = \sup\{q \cdot x : x \in \phi(B)\} = \text{spt}(q, \phi(B)).$$

Then ϕ^q is a signed measure with values in $(-\infty, \infty]$. However, we will only consider multimeasures for which $\phi(B)$ is bounded, so that, as we will see below, ϕ^q is a *finite* real-valued measure.

A multimeasure ϕ is defined to be *bounded* if $\phi(\mathbb{X})$ is bounded. If $E \in \mathcal{B}$ then

$$\phi(\mathbb{X}) = \phi(E) + \phi(\mathbb{X} \setminus E) \supseteq \phi(E) + a$$

for any $a \in \phi(\mathbb{X} \setminus E)$, and so $\phi(\mathbb{X})$ contains a translate of $\phi(E)$. Thus ϕ is *bounded* iff $\phi(A)$ is bounded for all $A \in \mathcal{B}$. In particular, if ϕ is bounded, then ϕ^q is a finite signed measure for any q

If $0 \neq a \in \phi(\emptyset)$ then $na \in \phi(\emptyset)$ for all natural numbers n and so $\phi(\emptyset)$ is unbounded and hence ϕ is unbounded. Thus $\phi(\emptyset) = \{0\}$ if ϕ is bounded.

The *range* of ϕ is defined to be $\bigcup_{A \in \mathcal{B}} \phi(A)$. *The range of ϕ is bounded iff ϕ is bounded.*

To see this let e_1, \dots, e_m be the standard basis for \mathbb{R}^m . Let $|\phi^{e_i}|$ and $|\phi^{-e_i}|$ be the total variation measures corresponding to ϕ^{e_i} and ϕ^{-e_i} (see below). Then for any $E \in \mathcal{B}$ and any $x \in \phi(E)$,

$$\begin{aligned} |x| &\leq \sum_{i=1}^m |x \cdot e_i| \leq \sum_{i=1}^m |\phi^{e_i}|(E) + |\phi^{-e_i}|(E) \\ &\leq \sum_{i=1}^m |\phi^{e_i}|(\mathbb{X}) + |\phi^{-e_i}|(\mathbb{X}). \end{aligned}$$

Since we assumed that ϕ was bounded, we know that $|\phi^q|(\mathbb{X})$ is finite for all q and thus

$$\text{range}(\phi) = \bigcup_{A \in \mathcal{B}} \phi(A) \subseteq \left\{ x : \|x\| \leq \sum_{i=1}^m |\phi^{e_i}|(\mathbb{X}) + |\phi^{-e_i}|(\mathbb{X}) \right\}.$$

An *atom* of the multimeasure ϕ is a set $A \in \mathcal{B}$ such that $\phi(A) \neq \{0\}$ but for all $B \in \mathcal{B}$ with $B \subset A$ either $\phi(B) = \{0\}$ or $\phi(A \setminus B) = \{0\}$. Suppose ϕ is bounded and *atomless* (i.e. has no atoms). Then $\phi(A)$ is *convex* for any A (this is a version of Lyapunov’s theorem for vector-valued measures) and the range of ϕ is also convex, see [2, Theorems 4.2, 4.4].

Moreover, if ϕ is bounded and atomless, then $\phi(\mathbb{X})$ is compact iff $\phi(A)$ is compact for all $A \in \mathcal{B}$, see [2, Theorems 4.2, 4.4].

If ϕ is a bounded multimeasure, then so are $\bar{\phi}$ defined by $\bar{\phi}(A) = \overline{\phi(A)}$, and ϕ^* defined by $\phi^*(A) = \text{co } \phi(A)$, the convex hull of $\phi(A)$, see [2, Propositions 4.5, 4.6].

Let $\mathbb{H}_c(\mathbb{R}^m)$ denote the set of non-empty compact convex subsets of \mathbb{R}^m . We will assume that all multimeasures ϕ take values in $\mathbb{H}_c(\mathbb{R}^m)$. By our comments above, assuming that ϕ is nonatomic and $\phi(\mathbb{X}) \in \mathbb{H}_c(\mathbb{R}^m)$ implies that $\phi(E) \in \mathbb{H}_c(\mathbb{R}^m)$ for any E . Thus it is not much of a restriction to assume convex values for our multimeasures.

3 Monge-Kantorovich Metric

In this section we extend the classical Monge-Kantorovich metric to multimeasures and generalize the metric in [21]. The Monge-Kantorovich metric is frequently used for studying IFSs, see the definitions and discussion in [5, 2. Preliminaries].

We begin with a discussion of the Monge-Kantorovich metric on signed measures because we use this as a preliminary step in defining the Monge-Kantorovich metric on multimeasures.

Assume, unless specified otherwise, that (\mathbb{X}, d) is a compact metric space and \mathcal{B} is the collection of Borel subsets of \mathbb{X} . We make this assumption for convenience only. Our extension is possible for \mathbb{X} a locally compact Polish space, but the technical details are more involved. In particular, it is necessary to assume a finite first-moment condition on the space of measures in addition to the fixed mass and boundedness conditions we already assume in Definition 3.1. Without such a condition there is no reason for the Monge-Kantorovich metric, as defined below, to be finite (see [28, Chapters 1, 7] for a general discussion).

Let $\mathcal{M}(\mathbb{X}, \mathbb{R})$ be the Banach space of finite signed measures μ defined on \mathcal{B} , together with the total variation norm $\|\cdot\|$ defined below.

By the Hahn Jordan decomposition theorem, μ is a finite signed measure iff $\mu = \mu^+ - \mu^-$ where μ^+ and μ^- are finite non-negative measures. The measures μ^+ and μ^- can be taken as mutually singular, in which case they are uniquely determined by μ .

The variation measure of μ is $|\mu| = \mu^+ + \mu^-$. The total variation of μ is defined by $\|\mu\| := |\mu|(\mathbb{X})$.

As usual, $C(\mathbb{X})$ denotes the collection of all continuous functions $f : \mathbb{X} \rightarrow \mathbb{R}$. By the Riesz representation theorem, $(\mathcal{M}(\mathbb{X}, \mathbb{R}), \|\cdot\|)$ is the dual space of $C(\mathbb{X})$ endowed with the supremum norm $\|f\|_\infty = \sup\{|f(x)| : x \in \mathbb{X}\}$.

Definition 3.1 Suppose $q \in \mathbb{R}$ and $k \geq |q|$. Let

$$\mathcal{M}_{q,k}(\mathbb{X}, \mathbb{R}) = \{\mu \in \mathcal{M}(\mathbb{X}, \mathbb{R}) : \mu(\mathbb{X}) = q, \|\mu\| \leq k\}.$$

The metric d_M on $\mathcal{M}_{q,k}(\mathbb{X}, \mathbb{R})$ is defined by

$$d_M(\mu, \nu) = \sup \left\{ \int_{\mathbb{X}} f d(\mu - \nu) : f \in \text{Lip}_1(\mathbb{X}) \right\}.$$

Notice that $\mathcal{M}_{q,k}(\mathbb{X}, \mathbb{R})$ is weak* compact as a subset of $\mathcal{M}(\mathbb{X}, \mathbb{R})$. To see this, we first note that bounded, norm-closed balls in $\mathcal{M}(\mathbb{X}, \mathbb{R})$ are weak* compact by the Banach-Alaoglu theorem. Then since $\mathcal{M}_{q,k}(\mathbb{X}, \mathbb{R})$ is norm-bounded and weak* closed, it is a weak* closed subset of a weak* compact set and thus is itself weak* compact. As a consequence, the weak* topology on $\mathcal{M}_{q,k}(\mathbb{X}, \mathbb{R})$ is metrizable and it turns out that our version of the Monge-Kantorovich metric yields this topology (see Proposition 3.4).

The requirement $\mu(\mathbb{X}) = q$ is a balancing condition which is necessary for d_M to be finite. The fact d_M is complete is shown in Theorem 3.3. The uniform mass bound is necessary for completeness as the following example shows.

Example 3.2. Take $\mathbb{X} = [-1, 1]$, $q = 0$, and temporarily drop the second condition in Definition 3.1.

Let $\mu_n = n\delta_{n^{-3}} - n\delta_{-n^{-3}}$. Then

$$\mu_n(\mathbb{X}) = 0, \quad d_M(\mu_n, 0) = 2n^{-2}, \quad \|\mu_n\| = 2n \rightarrow \infty \text{ as } n \rightarrow \infty.$$

Let $\nu_n = \sum_{i=1}^n \mu_i$. For $j > n$ we have

$$d_M(\nu_j, \nu_n) = d_M\left(\sum_{i=n+1}^j \mu_i, 0\right) \leq \sum_{i=n+1}^j d_M(\mu_i, 0) \leq 2 \sum_{i \geq n+1} i^{-2} \rightarrow 0 \text{ as } n \rightarrow \infty.$$

Thus the sequence $(\nu_n)_{n \geq 1}$ is a Cauchy sequence in the d_M metric.

However, ν_n cannot converge in the d_M metric to a (finite) signed measure ν since

$$\nu_n(0, 1) = -\nu_n(-1, 0) = 1 + 2 + \dots + n \rightarrow \infty.$$

More precisely, by looking at the supports of the ν_n one sees ν would have to agree on $[n^{-3}, 1]$ with ν_n , which contradicts the fact ν has finite mass.

The following result is probably known, but we include a proof since we cannot find one in the literature and we need this result for the sequel.

Theorem 3.3. $(\mathcal{M}_{q,k}(\mathbb{X}, \mathbb{R}), d_M)$ is a complete metric space.

Proof First we show that $d_M(\mu, \nu)$ is finite. Take $f \in \text{Lip}_1(\mathbb{X})$ and let $a \in \mathbb{X}$. Then

$$\begin{aligned} \left| \int f d(\mu - \nu) \right| &= \left| \int (f - f(a)) d(\mu - \nu) \right| \quad (\text{since } \mu(\mathbb{X}) = \nu(\mathbb{X}) = q) \\ &\leq \int |f - f(a)| d(|\mu| + |\nu|) \\ &\leq 2k \text{diam}(\mathbb{X}), \end{aligned}$$

where $\text{diam}(\mathbb{X})$ is the diameter of \mathbb{X} . It is obvious that $d_M(\mu, \nu) = d_M(\nu, \mu)$ and that $d(\mu, \nu) = 0$ if $\mu = \nu$. The triangle inequality is equally clear since $\sup A + B \leq \sup A + \sup B$. Suppose that $\mu \neq \nu$. Since $\mathcal{M}(\mathbb{X}, \mathbb{R})$ is the dual space to $C(\mathbb{X})$, we know that $C(\mathbb{X})$ separates the points of $\mathcal{M}(\mathbb{X}, \mathbb{R})$ and thus there is a $g \in C(\mathbb{X})$ with $\int g d\mu > \int g d\nu$. Since \mathbb{X} is compact and metric, Lipschitz functions are dense in $C(\mathbb{X})$ by the Stone-Weierstrass Theorem. Thus there exists an $f \in \text{Lip}_1(\mathbb{X})$ with $\int f d\mu > \int f d\nu$ and so $d_M(\mu, \nu) > 0$.

The only thing left to prove is completeness.

Suppose $(\mu_n)_{n \geq 1}$ is a d_M Cauchy sequence from $\mathcal{M}_{q,k}(\mathbb{X}, \mathbb{R})$. By weak* compactness of $\mathcal{M}_{q,k}(\mathbb{X}, \mathbb{R})$ there is a subsequence $(\mu_{n_k})_{k \geq 1}$ and a $\mu \in \mathcal{M}_{q,k}(\mathbb{X}, \mathbb{R})$ such that

$$\int f d\mu_{n_k} \rightarrow \int f d\mu \text{ for all } f \in C(\mathbb{X}).$$

Suppose $\epsilon > 0$. Since (μ_n) is d_M Cauchy, for all $n, n_k \geq N(\epsilon)$ we have that

$$\left| \int_{\mathbb{X}} f d\mu_{n_k} - \int_{\mathbb{X}} f d\mu_n \right| < \epsilon,$$

uniformly over $f \in \text{Lip}_1(\mathbb{X})$. Taking the limit as $k \rightarrow \infty$, we get

$$\left| \int_{\mathbb{X}} f \, d\mu - \int_{\mathbb{X}} f \, d\mu_n \right| \leq \epsilon,$$

independent of $f \in \text{Lip}_1(\mathbb{X})$. Thus $d_M(\mu, \mu_n) \rightarrow 0$. □

The classical Monge-Kantorovich metric on probability measures gives the weak* topology. It is not surprising that our extension also gives the weak* topology on $\mathcal{M}_{q,k}(\mathbb{X}, \mathbb{R})$, as we show in this next proposition. We do not use this result in the sequel, but include it for completeness and interest.

Proposition 3.4. *The Monge-Kantorovich metric d_M on $\mathcal{M}_{q,k}(\mathbb{X}, \mathbb{R})$ yields the weak* topology.*

Proof Since Lipschitz functions are dense in $C(\mathbb{X})$, convergence in the d_M metric on $\mathcal{M}_{q,k}(\mathbb{X}, \mathbb{R})$ implies weak* convergence. Thus any weak* closed set is also d_M -closed and so the topology induced by d_M on $\mathcal{M}_{q,k}(\mathbb{X}, \mathbb{R})$ is finer than the weak* topology. Next we note that $\mathcal{M}_{q,k}(\mathbb{X}, \mathbb{R})$ is compact and Hausdorff under the weak* topology and is Hausdorff under the metric d_M . We will show that $\mathcal{M}_{q,k}(\mathbb{X}, \mathbb{R})$ is also compact under the metric d_M . Since any Hausdorff topology is maximal among compact topologies [30, 17C], this means that the d_M topology must coincide with the weak* topology on $\mathcal{M}_{q,k}(\mathbb{X}, \mathbb{R})$.

We show that $\mathcal{M}_{q,k}(\mathbb{X}, \mathbb{R})$ is totally bounded under the d_M metric, and thus since we already know it is complete this means that it must be compact. Let $\epsilon > 0$ be given and $\alpha = \epsilon / (2k + 1)$. Since \mathbb{X} is compact, there are x_i , for $i = 1, 2, \dots, N$, so that $\mathbb{X} = \cup_i B_\alpha(x_i)$. Let A_i be a partition of \mathbb{X} with $x_i \in A_i \subseteq B_\alpha(x_i)$. Now, the set

$$P = \{(p_1, p_2, \dots, p_N) \in \mathbb{R}^N : \sum_i p_i = q, \sum_i |p_i| \leq k\}$$

is compact and $\Phi : P \rightarrow \mathcal{M}_{q,k}(\mathbb{X}, \mathbb{R})$ given by $\Phi(p_1, p_2, \dots, p_N) = \sum_i p_i \delta_{x_i}$ is continuous in the d_M metric. Thus, $\Phi(P) \subseteq \mathcal{M}_{q,k}(\mathbb{X}, \mathbb{R})$ is also compact.

Take $\mu \in \mathcal{M}_{q,k}(\mathbb{X}, \mathbb{R})$ and define $p_i = \mu(A_i)$ and $\nu = \Phi(p_1, p_2, \dots, p_N)$. Then

$$\begin{aligned} \sup_{f \in \text{Lip}_1(\mathbb{X})} \int f \, d(\mu - \nu) &= \sup_{f \in \text{Lip}_1(\mathbb{X})} \sum_i \int_{A_i} f \, d(\mu - \nu) \\ &\leq \sum_i \sup_{f_i \in \text{Lip}_1(A_i)} \int_{A_i} f_i \, d(\mu \llcorner A_i - p_i \delta_{x_i}) \\ &= \sum_i d_M(\mu \llcorner A_i, p_i \delta_{x_i}) \\ &\leq \sum_i |p_i| \text{diam}(A_i) \leq 2\alpha \sum_i |p_i| \leq 2k\alpha. \end{aligned}$$

This means that the $(2k\alpha)$ -dilation of $\Phi(P)$ covers $\mathcal{M}_{q,k}(\mathbb{X}, \mathbb{R})$. Finally, since $\Phi(P)$ is d_M -compact, we can find $\mu_1, \mu_2, \dots, \mu_\ell \in \Phi(P)$ for which $\cup_i B_\alpha(\mu_i) = \Phi(P)$. But then the μ_i form an ϵ -net for $\mathcal{M}_{q,k}(\mathbb{X}, \mathbb{R})$ since

$$\begin{aligned} \mathcal{M}_{q,k}(\mathbb{X}, \mathbb{R}) &\subseteq \{\mu \in \mathcal{M}_{q,k}(\mathbb{X}, \mathbb{R}) : d_M(\mu, \Phi(P)) < 2k\alpha\} \\ &\subseteq \{\mu \in \mathcal{M}_{q,k}(\mathbb{X}, \mathbb{R}) : d_M(\mu, \mu_i) < (2k + 1)\alpha, \text{ for some } \mu_i\}. \end{aligned}$$

Thus $\mathcal{M}_{q,k}(\mathbb{X}, \mathbb{R})$ is totally bounded under the metric d_M and so is compact. □

We now extend the Monge-Kantorovich metric to set-valued measures.

Definition 3.5 Fix $Q, K \in \mathbb{H}_c(\mathbb{R}^m)$ with $Q \subseteq K$. Let $\mathcal{M}_{Q,K}(\mathbb{X}, \mathbb{R}^m)$ be the set of all Borel multimeasures ϕ on \mathbb{X} , with values in $\mathbb{H}_c(\mathbb{R}^m)$, and such that $\phi(\mathbb{X}) = Q$ and $\phi(E) \subseteq K$ for all E .

We note that $\mathcal{M}_{Q,K}(\mathbb{X}, \mathbb{R}^m) \neq \emptyset$ since the point mass $Q\delta_x$ is in $\mathcal{M}_{Q,K}(\mathbb{X}, \mathbb{R}^m)$ for any $x \in \mathbb{X}$. Notice if $0 \in \phi(\mathbb{X} \setminus E)$, then

$$\phi(E) = \{0\} + \phi(E) \subseteq \phi(\mathbb{X} \setminus E) + \phi(E) = \phi(\mathbb{X}).$$

Thus, under the condition that $0 \in \phi(E)$ for all E , we can use $K = Q$. In general, the assumption that $\phi(\mathbb{X}) = Q$ is bounded implies that the range of ϕ is bounded and thus contained in a compact set. This means that $\phi(\mathbb{X}) = Q$ is enough to guarantee that there is some K with $\phi(E) \subseteq K$ for all E .

Let $S_1 = \{x \in \mathbb{R}^m : \|x\| = 1\}$ be the unit sphere in \mathbb{R}^m . It is important to note that $\phi \in \mathcal{M}_{Q,K}(\mathbb{X}, \mathbb{R}^m)$ and $p \in S_1$ implies that $\phi^p \in \mathcal{M}_{q,k}(\mathbb{X}, \mathbb{R})$ where

$$q = \text{spt}(p, Q) \quad \text{and} \quad k \geq |\text{spt}(p, K)| + |\text{spt}(-p, K)|.$$

Definition 3.6 We define the following function on $\mathcal{M}_{Q,K}(\mathbb{X}, \mathbb{R}^m)$,

$$\hat{d}_M(\phi_1, \phi_2) = \sup_{p \in S_1} d_M(\phi_1^p, \phi_2^p).$$

Lemma 3.7 Given two multimeasures ϕ_1 and ϕ_2 suppose that $\phi_1^p(A) = \phi_2^p(A)$ for all $p \in S_1$ and $A \in \mathcal{B}$. Then $\phi_1(A) = \phi_2(A)$ for all $A \in \mathcal{B}$.

Proof Suppose that there exists $A^* \in \mathcal{B}$ such that $\phi_1(A^*) \neq \phi_2(A^*)$. Without any loss of generality, suppose that there exists a point $l \in \phi_1(A^*)$ with $l \notin \phi_2(A^*)$. Using a standard separation argument in \mathbb{R}^m , we get a vector $p^* \in S_1$ such that $p^*l > p^*y$ for all $y \in \phi_2(A^*)$ and so $\phi_1^{p^*}(A^*) > \phi_2^{p^*}(A^*)$, which is a contradiction. □

Theorem 3.8 $(\mathcal{M}_{Q,K}(\mathbb{X}, \mathbb{R}^m), \hat{d}_M)$ is a metric space.

Proof Let $\phi_1, \phi_2 \in \mathcal{M}_{Q,K}(\mathbb{X}, \mathbb{R}^m)$. We first observe that for all $p \in S_1$ the signed measures ϕ_1^p and ϕ_2^p have equal mass $\phi_1^p(\mathbb{X}) = \phi_2^p(\mathbb{X}) = \text{spt}(p, Q)$.

Fix $p \in S^1$ and $a \in \mathbb{X}$. Then

$$\begin{aligned} \int_{\mathbb{X}} f(x)d(\phi_1^p - \phi_2^p)(x) &= \int_{\mathbb{X}} (f(x) - f(a))d(\phi_1^p - \phi_2^p)(x) \\ &\leq \text{diam}(\mathbb{X}) \int_{\mathbb{X}} d(|\phi_1^p| + |\phi_2^p|)(x) = \text{diam}(\mathbb{X})(|\phi_1^p|(\mathbb{X}) + |\phi_2^p|(\mathbb{X})) \\ &\leq 2 \text{diam}(\mathbb{X})(|\text{spt}(p, K)| + |\text{spt}(-p, K)|) \leq 4 \text{diam}(\mathbb{X}) \sup_{y \in K} \|y\|. \end{aligned}$$

Thus $\hat{d}_M(\phi_1, \phi_2) < \infty$ (in fact, this shows that the diameter of $\mathcal{M}_{Q,K}(\mathbb{X}, \mathbb{R}^m)$ is bounded).

Suppose that $\hat{d}_M(\phi_1, \phi_2) = 0$ then this implies $\phi_1^p(A) = \phi_2^p(A)$ for all $p \in S_1$ and $A \in \mathcal{B}$ and so, using the previous lemma, we get $\phi_1 = \phi_2$. The other properties can be easily proved. □

The following lemma is taken from the discussion in section 8.E of [24], and especially Theorem 8.24.

Lemma 3.9 *If $s(p)$ is a convex function from \mathbb{R}^m to $(-\infty, +\infty)$ which is positively homogeneous, then it is the support function of a certain compact and convex set A , namely*

$$A = \bigcap_{p \in \mathbb{R}^m} \{x : p \cdot x \leq s(p)\}.$$

Note that since $s(p) \neq \infty$ for all $p \in \mathbb{R}^m$, the convexity implies the continuity of $s(p)$.

Lemma 3.10 *Let $\mu_p, p \in \mathbb{R}^m$, be a family of signed measures on the Borel subsets \mathcal{B} of \mathbb{X} and suppose that the function $p \rightarrow \mu_p(E)$ is convex, positively homogeneous and $|\mu_p(E)| < \infty$ for all $E \in \mathcal{B}$. Define $\phi : \mathcal{B} \rightarrow \mathbb{H}_c(\mathbb{R}^m)$ by*

$$\phi(E) = \bigcap_{p \in S_1} \{x \in \mathbb{R}^m : x \cdot p \leq \mu_p(E)\}$$

for all $E \in \mathcal{B}$. Then ϕ is a multimeasure and $\phi^p = \mu_p$ for all $p \in S_1$.

Proof We give the idea of how to prove the additive property. For simplicity, we restrict to the case of two disjoint sets A_1, A_2 . First, we comment that by Lemma 3.9 and positive homogeneity, we have $\mu_p(E) = \text{spt}(p, \phi(E))$ for all p and $E \in \mathcal{B}$.

Since each μ_p is a signed measure, $\mu_p(A_1 \cup A_2) = \mu_p(A_1) + \mu_p(A_2)$. For $x \in \phi(A_1)$ and $y \in \phi(A_2)$, we see that

$$(x + y) \cdot p = x \cdot p + y \cdot p \leq \mu_p(A_1) + \mu_p(A_2) = \mu_p(A_1 \cup A_2)$$

for all p and thus $x + y \in \phi(A_1 \cup A_2)$ so $\phi(A_1) + \phi(A_2) \subseteq \phi(A_1 \cup A_2)$.

For the reverse inclusion, suppose that $z \in \phi(A_1 \cup A_2)$ with $z \notin \phi(A_1) + \phi(A_2)$. Since $\phi(A_1) + \phi(A_2)$ is a compact and convex set, there is some p^* so that

$$z \cdot p^* > (x + y) \cdot p^*, \quad \text{for all } x \in \phi(A_1), y \in \phi(A_2).$$

However, since $\phi(A_1), \phi(A_2)$ are compact, there are $x^* \in \phi(A_1)$ and $y^* \in \phi(A_2)$ with $x^* \cdot p^* = \text{spt}(p^*, \phi(A_1)) = \mu_{p^*}(A_1)$ and $y^* \cdot p^* = \text{spt}(p^*, \phi(A_2)) = \mu_{p^*}(A_2)$ so that

$$(x^* + y^*) \cdot p^* < z \cdot p^* \leq \mu_{p^*}(A_1 \cup A_2) = \mu_{p^*}(A_1) + \mu_{p^*}(A_2),$$

which is a contradiction. □

Theorem 3.11 *The metric space $(\mathcal{M}_{Q,K}(\mathbb{X}, \mathbb{R}^m), \hat{d}_M)$ is complete.*

Proof Let ϕ_n be a Cauchy sequence in $\mathcal{M}_{Q,K}(\mathbb{X}, \mathbb{R}^m)$. For any fixed p we know that ϕ_n^p is a d_M -Cauchy sequence by the definition of \hat{d}_M . Additionally, $\phi_n^p(\mathbb{X}) = \text{spt}(p, \phi_n(\mathbb{X})) = \text{spt}(p, Q)$ for any p . Thus $\phi_n^p \rightarrow \mu_p$ for some signed measure μ_p , by Theorem 3.3, with convergence in d_M uniformly over $p \in S_1$. We also observe that $\mu_p(\mathbb{X}) = \text{spt}(p, Q)$. Since

$$|\phi_n^p(E)| = |\text{spt}(p, \phi_n(E))| \leq |\text{spt}(p, K)| \leq \sup_{l \in K} \|l\| := \gamma,$$

$\phi_n^p(E)$ is uniformly bounded in p and n .

We now show that $\mu_p(E)$ (as p varies over S_1) is a support function for any given $E \in \mathcal{B}$. For this we show that (as a function of $p \in \mathbb{R}^m$):

- $p \rightarrow \mu_p(E)$ is convex, and

- $p \rightarrow \mu_p(E)$ is positively homogeneous.

For all n and E , the functions $p \rightarrow \phi_n^p(E)$ (being support functions) are convex and positively homogeneous. From this we obtain that for all $\alpha \in \mathbb{R}_+$, for $p, p_1, p_2 \in \mathbb{R}^m$ and $E \in \mathcal{B}$,

$$\phi_n^{\alpha p}(E) - \alpha \phi_n^p(E) = 0$$

and

$$\phi_n^{p_1}(E) + \phi_n^{p_2}(E) - \phi_n^{p_1+p_2}(E) \geq 0.$$

Taking the limit as n tends to infinity we get that $p \rightarrow \mu_p(E)$ is subadditive and positively homogeneous which implies that $p \rightarrow \mu_p(E)$ is convex. Similarly $|\mu_p(E)| \leq \gamma$ for all $E \in \mathcal{B}$ and so $p \mapsto \mu_p(E)$ is continuous in p for any fixed $E \in \mathcal{B}$, being convex and bounded. Define ϕ by

$$\phi(E) = \bigcap_{p \in \mathcal{S}_1} \{x \in \mathbb{R}^m : x \cdot p \leq \mu_p(E)\}.$$

To show that $\phi(\mathbb{X}) = Q$, we first note that

$$Q \subseteq \phi(\mathbb{X}) = \bigcap_{p \in \mathcal{S}_1} \{x \in \mathbb{R}^m : x \cdot p \leq \mu_p(\mathbb{X})\} = \bigcap_{p \in \mathcal{S}_1} \{x \in \mathbb{R}^m : x \cdot p \leq \sup_{l \in Q} l \cdot p\}.$$

For the reverse inclusion, if there exists $x^* \in \phi(\mathbb{X})$ and $x^* \notin Q$ then, using a standard separation argument in \mathbb{R}^m , we see there exists p^* such that $p^* \cdot x^* > p^* \cdot l$ for all $l \in Q$. Since Q is compact this implies that (by taking a maximum) $p^* \cdot x^* > \sup_{l \in Q} p^* \cdot l$, which is a contradiction. Thus $Q = \phi(\mathbb{X})$. Showing that $\phi(E) \subseteq K$ is done in a similar manner. Finally, ϕ is a multimeasure and $\text{spt}(p, \phi) = \mu_p$, that is $\phi_n \rightarrow \phi$ in the \hat{d}_M metric. \square

4 IFS Markov Operators

We now turn to the definition of an IFS Markov operator on $\mathcal{M}_{Q,K}(\mathbb{X}, \mathbb{R}^m)$. First we briefly describe the construction for probability measures [15], as we follow the same pattern.

Let \mathbb{X} be a complete metric space and let \mathcal{B} be the corresponding Borel σ -algebra. Let $w_i : \mathbb{X} \rightarrow \mathbb{X}$ for $i \in \{1, 2, \dots, N\}$ be Lipschitz with the Lipschitz factor for w_i being c_i . Let $(p_i)_{i=1}^N$ be a collection of probabilities such that $p_i > 0$ and $\sum_i p_i = 1$. This determines the IFS with probabilities (IFSP) w_i, p_i for $i = 1 \dots N$. The Markov operator M associated to this IFSP is an operator on probability measures μ over $(\mathbb{X}, \mathcal{B})$ that is defined by

$$M\mu(B) = \sum_i p_i \mu(w_i^{-1}(B)) \tag{2}$$

for all $B \in \mathcal{B}$. If μ is supported on B and the $w_i(B)$ are mutually disjoint then the result of this operator is to assign probability p_i to $w_i(B)$, that is, $M\mu(w_i(B)) = p_i$. A second application of M assigns probability $p_i p_j$ to the set $w_i(w_j(B))$, a third application assigns probability $p_i p_j p_k$ to the set $w_i(w_j(w_k(B)))$, and so on. This recursively distributes a limit probability measure over \mathbb{X} which is supported on the fractal set defined by the w_i 's. If $\sum_i p_i c_i < 1$, then M is contractive in the Monge-Kantorovich metric and thus has a unique fixed point, the *invariant measure* of the IFSP.

For our operator on multimeasures, we again take Lipschitz $w_i : \mathbb{X} \rightarrow \mathbb{X}$ for $i = 1, 2, \dots, N$. We also take linear functions $T_i : \mathbb{R}^m \rightarrow \mathbb{R}^m$ with $\sum_i T_i Q = Q$ and $\sum_{i \in S} T_i K \subseteq K$ for all $S \subseteq \{1, 2, \dots, N\}$ (the choice $K = \lambda Q$ for $\lambda \geq 1$ often works, but

might be overly restrictive). We define the IFS operator

$$M\phi(B) = \sum_i T_i \left(\phi(w_i^{-1}(B)) \right)$$

for all $B \in \mathcal{B}$. A simple argument shows that $M\phi \in \mathcal{M}_{Q,K}(\mathbb{X}, \mathbb{R}^m)$ whenever $\phi \in \mathcal{M}_{Q,K}(\mathbb{X}, \mathbb{R}^m)$ (to see this, it is useful to note that each T_i is continuous with respect to the Hausdorff metric since T_i is linear, and thus Lipschitz). Further, since each T_i is linear and ϕ takes convex values, if $\phi(E) \subseteq \phi(\mathbb{X}) = Q$ for all E , then $M\phi(E) \subseteq Q$ for all E as well.

The condition $\sum_{i \in S} T_i K \subseteq K$ for all $S \subseteq \{1, 2, \dots, N\}$ seems like it might be quite strong. However, if $0 \in K$ and $\sum_{i=1}^N T_i K \subseteq K$, then for any $S \subseteq \{1, 2, \dots, N\}$

$$\sum_{i \in S} T_i K \subseteq \sum_{i=1}^N T_i K \subseteq K.$$

Theorem 4.1 *For the IFS Markov operator defined above we have*

$$\hat{d}_M(M\phi_1, M\phi_2) \leq \left(\sum_i c_i \|T_i\| \right) \hat{d}_M(\phi_1, \phi_2)$$

for all $\phi_1, \phi_2 \in \mathcal{M}_{Q,K}(\mathbb{X}, \mathbb{R}^m)$.

Proof First we note that for linear T and convex A , we have

$$\begin{aligned} \sup_{p \in \mathcal{S}_1} \text{spt}(p, TA) &= \sup_{x \in TA} \sup_{p \in \mathcal{S}_1} p \cdot x = \sup_{y \in A} \|Ty\| \\ &\leq \|T\| \sup_{y \in A} \|y\| = \|T\| \sup_{p \in \mathcal{S}_1} \sup_{y \in A} p \cdot y \\ &= \sup_{p \in \mathcal{S}_1} \|T\| \text{spt}(p, A). \end{aligned}$$

For a given Lipschitz f , we have

$$\begin{aligned} &\sup_{p \in \mathcal{S}_1} \int_{\mathbb{X}} f(x) d[\text{spt}(p, M\phi_1(x)) - \text{spt}(p, M\phi_2(x))] \\ &= \sup_{p \in \mathcal{S}_1} \int_{\mathbb{X}} f(x) d \left[\text{spt}(p, \sum_i T_i \phi_1(w_i^{-1}(x))), \text{spt}(p, \sum_i T_i \phi_2(w_i^{-1}(x))) \right] \\ &= \sup_{p \in \mathcal{S}_1} \int_{\mathbb{X}} f(x) \sum_i d \left[\text{spt}(T_i^* p, \phi_1(w_i^{-1}(x))) - \text{spt}(T_i^* p, \phi_2(w_i^{-1}(x))) \right] \\ &\leq \sup_{p \in \mathcal{S}_1} \int_{\mathbb{X}} \left\{ \sum_i \|T_i\| f(w_i(y)) \right\} d[\text{spt}(p, \phi_1(y)) - \text{spt}(p, \phi_2(y))]. \end{aligned}$$

The function $\tilde{f} = \sum_i \|T_i\| f \circ w_i$ has Lipschitz factor at most $\sum_i c_i \|T_i\|$. Taking the supremum over all Lipschitz functions, we get that

$$\hat{d}_M(M\phi_1, M\phi_2) \leq \left(\sum_i c_i \|T_i\| \right) \hat{d}_M(\phi_1, \phi_2),$$

as was desired. □

We say that the IFS operator M is *average contractive* if $\sum_i c_i \|T_i\| < 1$. Notice that this is the natural generalization of the usual average contractive condition for a standard IFS

with probability weights. The following theorem is an immediate corollary of Theorems 3.11 and 4.1.

Theorem 4.2 *Suppose that M is an average contractive IFS operator on $\mathcal{M}_{Q,K}(\mathbb{X}, \mathbb{R}^m)$. Then there is a unique invariant “fractal” multimeasure $\phi \in \mathcal{M}_{Q,K}(\mathbb{X}, \mathbb{R}^m)$ for M .*

Example 4.3 As a first example, we choose $K = Q \subset \mathbb{R}^m$ to be the closed unit ball and $\mathbb{X} = [0, 1]$ with $w_i(x) = x/2 + i/2$ for $i = 0, 1$. Further let $p_0 \in (0, 1)$ and $p_1 = 1 - p_0$ and define $T_i = p_i I$. Then the invariant multimeasure for the IFS Markov operator

$$M\phi(B) = T_0\phi(w_0^{-1}(B)) + T_1\phi(w_1^{-1}(B))$$

is the measure $Q\mu$ where μ is the probability measure which is the invariant distribution for the standard IFS with maps $\{w_0, w_1\}$ and probabilities $\{p_0, p_1\}$. In this case, the multimeasure is rather simple, being the product of the scalar (probability) measure μ and the set Q .

Example 4.4 Let $\mathbb{X} = [0, 1]$, $w_0(x) = x/3$, $w_1(x) = x/3 + 2/3$ (so $c_0 = c_1 = 1/3$) and

$$T_0(x, y) = \begin{pmatrix} \alpha & 0 \\ 0 & 1 - \alpha \end{pmatrix} \begin{pmatrix} x \\ y \end{pmatrix}, \quad T_1(x, y) = \begin{pmatrix} 1 - \alpha & 0 \\ 0 & \alpha \end{pmatrix} \begin{pmatrix} x \\ y \end{pmatrix},$$

with $1/2 < \alpha < 1$. Now, let $K = Q = [-1, 1]^2 \subset \mathbb{R}^2$. It is easy to see that $T_0(Q) + T_1(Q) = Q$. In this case, the invariant multimeasure ϕ is supported on the classical Cantor Set and the values are rectangles which are more “horizontal” to the left and more “vertical” to the right.

Figure 1 illustrates both of these types of multimeasure attractors by showing a type of “density” for each them. For the “circular” example we use $p_0 = 0.3$ and $p_1 = 0.7$ while for the “rectangular” example we have $\alpha = 0.7$.

The next example is a nice generalization of our second example and is really an entire class of examples.

Example 4.5 A set $Q \subset \mathbb{R}^m$ is a *zonotope* if $Q = l_1 + l_2 + \dots + l_p$ where $l_i \subset \mathbb{R}^m$ are (closed) line segments. Many natural convex sets are zonotopes or can be approximated by zonotopes, see [6, 20]. By translating we can assume that l_i has its midpoint at the origin, so that $l_i \subset Q$ and $Q = -Q$. Let $Q = l_1 + l_2 + \dots + l_p \subset \mathbb{R}^m$ be a zonotope as above,

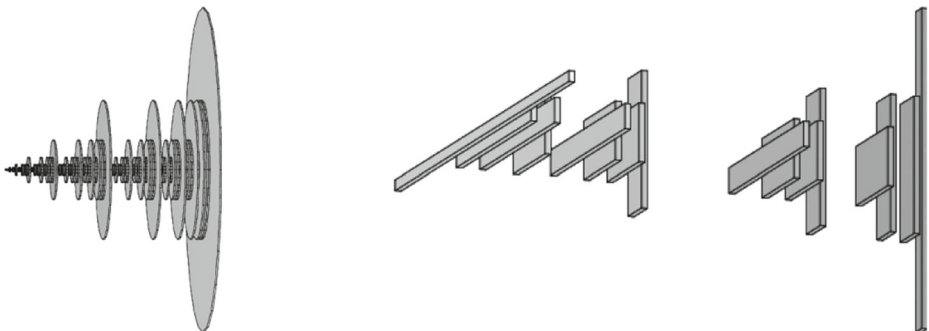

Fig. 1 Circular and rectangular multimeasures

and let $P_i : \mathbb{R}^m \rightarrow \mathbb{R}^m$ be the orthogonal projection onto the subspace spanned by l_i . Further, let $\alpha_i = |l_i|/\text{diam}(P_i Q)$, and let $T_i = \alpha_i P_i$. Note that $\alpha_i < 1$. Then $l_i = T_i Q$ so $\sum_i T_i Q = Q$. Let $K = Q$.

Take any IFS maps $w_j : \mathbb{X} \rightarrow \mathbb{X}$ for $j = 1, 2, \dots, N$ with contraction factors c_j and take $\beta_{i,j} \in [0, 1]$ with $\sum_j \beta_{i,j} = 1$. Define $T_{i,j} = \beta_{i,j} T_i$ so that $T_i = \sum_j T_{i,j}$. Notice that $Q = \sum_{i,j} T_{i,j} Q$. Finally, we define M on $\mathcal{M}_{Q,Q}(\mathbb{X}, \mathbb{R}^m)$ by

$$M\phi(B) = \sum_{i,j} T_{i,j} \phi(w_j^{-1}(B)).$$

By a simple calculation we see that M is average contractive if $\sum_i c_i \alpha_i < 1$.

Acknowledgments This work was started during a research visit of DLT and FM to the Department of Applied Math at the University of Waterloo. Then it was continued during a research period of DLT at the Department of Mathematics of the Australian National University, Canberra, Australia. DLT thanks Prof. Hutchinson for this opportunity. FM gratefully acknowledges support for this work from the Natural Sciences and Engineering Research Council of Canada (NSERC).

The authors would like to thank Prof. Hutchinson for all the help he gave to us including numerous suggestions which substantially improved our paper. In particular, we thank him for the example of the zonotopes.

References

1. Alo, R., de Korvin, A., Roberts C. Jr.: On some properties of continuous multimeasures. *J. Math. Anal. Appl.* **75**, 402–410 (1980)
2. Artstein, Z.: Set-valued measures. *Trans AMS* **165**, 103–125 (1972)
3. Baron, K., Lasota, A.: Markov operators on the space of vector measures; coloured fractals. *Ann. Polon. Math.* **69**(3), 217–234 (1998)
4. Barnsley, M.F., Demko, S.: Iterated function systems and the global construction of fractals. *Proc. Roy. Soc. London Ser. A* **399**, 243–275 (1985)
5. Barnsley, M.F., Hutchinson, J.E., Stenflo, O.: *V*-variable fractals: fractals with partial self similarity. *Adv. Math.* **218**(6), 2051–2088 (2008)
6. Bolker, E.D.: A class of convex bodies. *Trans. Amer. Math. Soc.* **145**, 323–345 (1969)
7. Brooks, J.K.: An integration theory for set-valued measures. *Bull. Soc. Roy. de Sci. Liege* **37**(5), 312–319 (1968)
8. Debreu, G., Schmeidler, D.: The Radon-Nikodym derivative of a correspondence. In: Lecam, L., Neyman, J., Scott, E.L. (eds.) *Proceedings of Fifth Berkeley Symposium Math. Stat. and Probability. II, Part 1*, pp. 351–372. Berkely: University of California Press (1967)
9. Drewnowski, L.: Additive and countably additive correspondences. *Comment. Math.* **19**, 25–53 (1976)
10. Falconer, K.J., O’Neil, T.: Vector-valued multifractal measures. *Proc. Roy Soc. London Ser. A* **452**(1949), 1433–1457 (1996)
11. Forte, B., Mendivil, F., Vrscay, E.R.: IFS operators on integral transforms, in *Fractals: Theory and Applications in Engineering*. In: Dekking, M., Levy-Vehel, J., Lutton, E., Tricot, C. (eds.) Springer Verlag, London (1999)
12. Forte, B., Vrscay, E.R.: Theory of generalized fractal transforms, *Fractal Image Encoding and Analysis*, NATO ASI, Series, F, vol. 159. In: Fisher, Y. (ed.) Springer Verlag, New York (1998)
13. Hermes, H.: Calculus of set-valued functions and control. *J. Math. Mech.* **18**, 47–59 (1968/1969)
14. Hildenbrand, W.: *Core and Equilibria of a Large Economy*, Princeton Univ. Press. Princeton, New York (1974)
15. Hutchinson, J.: Fractals and self-similarity. *Indiana Univ. J. Math.* **30**, 713–747 (1981)
16. Iacus, S.M., La Torre, D.: A comparative simulation study on the IFS distribution function estimator. *Nonlinear Anal. Real World Appl.* **6**, 774–785 (2005)
17. Kandilakis, D.: On the extension of multimeasures and integration with respect to a multimeasure. *Proc. AMS* **116**(1), 85–92 (1992)
18. Kantorovich, L.V., Rubinstein, G.Sh.: On a functional space and certain extremal problems. *Dokl. Akad. Nauk SSSR* **115**, 1058–1061 (1957). in Russian

19. Kantorovich, L.V., Rubinstein, G.Sh.: On a space of completely additive functions. *Vestnik. Leningrad. Univ. Math.* **13**, 52–59 (1958). (in Russian)
20. Koshevoy, G.: The Lorenz zonotope and multivariate majorizations. *Soc. Choice Welf.* **15**(1), 1–14 (1998)
21. Mendivil, F., Vrscay, E.R.: Fractal vector measures and vector calculus on planar fractal domains. *Chaos Solitons Fractals* **14**, 1239–1254 (2002)
22. Parthasarathy, K.R.: *Probability Measures on Metric Spaces*. Academic Press, New York (1967)
23. Rachev, S.T.: *Probability Metrics and the Stability of Stochastic Models*. Wiley, Chichester (1991)
24. Rockafellar, R.T., Wets, R.J.-B.: *Variational analysis*. Springer, New York (1998)
25. Rockafellar, R.T.: *Integral functional, normal integrands and measurable selectors*, Lecture Notes in Math. N. 543. Springer Verlag Berlin (1976)
26. Strassen, V.: The existence of probability measures with given marginals. *Ann. Math. Stat.* **36**, 423–439 (1965)
27. Vershik, A.M.: Kantorovich metric: Initial history and little-known applications. *J. Math. Sci.* **133**(4), 1410–1417 (2006)
28. Villani, C.: *Topics in optimal transportation*. AMS (2003)
29. Vind, K.: Edgeworth-allocations in an exchange economy with many traders. *Int. Econ. Rev.* **5**(2), 165–177 (1964)
30. Willard, S.: *General Topology*. Addison-Wesley (1970)