

Regolith X-Ray Imaging Spectrometer (REXIS) Aboard the OSIRIS-REx Asteroid Sample Return Mission

R.A. Masterson¹ · M. Chodas¹ · L. Bayley¹ · B. Allen² · J. Hong² · P. Biswas¹ · C. McMenamin¹ · K. Stout¹ · E. Bokhour¹ · H. Bralower¹ · D. Carte¹ · S. Chen¹ · M. Jones¹ · S. Kissel³ · F. Schmidt¹ · M. Smith¹ · G. Sondecker¹ · L.F. Lim⁴ · D.S. Lauretta⁵ · J.E. Grindlay² · R.P. Binzel⁶

Received: 13 April 2017 / Accepted: 2 February 2018 / Published online: 12 February 2018
© Springer Science+Business Media B.V., part of Springer Nature 2018

Abstract The Regolith X-ray Imaging Spectrometer (REXIS) is the student collaboration experiment proposed and built by an MIT-Harvard team, launched aboard NASA's OSIRIS-REx asteroid sample return mission. REXIS complements the scientific investigations of other OSIRIS-REx instruments by determining the relative abundances of key elements present on the asteroid's surface by measuring the X-ray fluorescence spectrum (stimulated by the natural solar X-ray flux) over the range of energies 0.5 to 7 keV. REXIS consists of two components: a main imaging spectrometer with a coded aperture mask and a separate solar X-ray monitor to account for the Sun's variability. In addition to element abundance ratios (relative to Si) pinpointing the asteroid's most likely meteorite association, REXIS also maps elemental abundance variability across the asteroid's surface using the asteroid's rotation as well as the spacecraft's orbital motion. Image reconstruction at the highest resolution is facilitated by the coded aperture mask. Through this operation, REXIS will be the first application of X-ray coded aperture imaging to planetary surface mapping, making this student-built instrument a pathfinder toward future planetary exploration. To date, 60 students at the undergraduate and graduate levels have been involved with the REXIS project, with the hands-on experience translating to a dozen Master's and Ph.D. theses and other student publications.

OSIRIS-REx

Edited by Dante Lauretta and Christopher T. Russell

✉ R.A. Masterson
becki@mit.edu

¹ Space Systems Laboratory, Department of Aeronautics and Astronautics, Massachusetts Institute of Technology, Cambridge, MA, USA

² Harvard College Observatory, 60 Garden Street, Cambridge, MA, USA

³ MIT Kavli Institute for Astrophysics and Space Research, Massachusetts Institute of Technology, Cambridge, MA, USA

⁴ Goddard Space Flight Center, Greenbelt, MD, USA

⁵ Lunar and Planetary Laboratory, University of Arizona, Tucson, AZ, USA

⁶ Department of Earth, Atmospheric, and Planetary Sciences, Massachusetts Institute of Technology, Cambridge, MA, USA

Keywords Asteroids · Meteorites · Spectroscopy · OSIRIS-REx

Acronyms and Abbreviations

ADC	analog to digital converter
CCD	charge-coupled device
CDIO	Conceive, Design, Implement and Operate
CDR	Critical Design Review
CTI	charge transfer inefficiency
CXB	Cosmic X-ray Background
CXEL	candidate X-ray event list
DAM	detector assembly mount
DASS	detector assembly support structure
DE	Detector Electronics
EAPS	Department of Earth, Atmospheric, and Planetary Sciences
EM	Engineering Model
ETU	Engineering Test Unit
FFT	fast Fourier transform
FM	Flight Model
FoV	field of view
FPGA	field programmable gate array
FWHM	full-width at half-maximum
FWMI	full-width maximum intensity
MEB	Main Electronics Board
MLI	multi-layer insulation
nCi	nano-Curies
OBF	optical blocking filter
OSIRIS-Rex	Origins-Spectral Interpretation-Resource Identification-Security-Regolith Explorer
PDR	Preliminary Design Review
QE	quantum efficiency
REXIS	Regolith X-ray Imaging Spectrometer
SBB	SXM Backpack Board
SDD	silicon drift diode
SDR	System Definition Review
SEB	SXM Electronics Board
SRR	System Requirements Review
SXM	Solar X-ray Monitor
TEC	thermoelectric cooler
TIL	thermal isolation layer
TVAC	thermal-vacuum chamber
UROp	Undergraduate Research Opportunities Program

1 Introduction

NASA's Origins-Spectral Interpretation-Resource Identification-Security-Regolith Explorer (OSIRIS-REx) is a New Frontiers class mission launched in September 2016 to study the asteroid (101955) Bennu and return a sample to the Earth. (See Lauretta et al. 2015 for a

Fig. 1 Operational concept (not to spatial scale) for the Regolith X-ray Image Spectrometer (REXIS) student collaboration experiment in flight aboard NASA's OSIRIS-REx asteroid sample return mission. Atomic elements fluoresced in the regolith of asteroid Bennu at the site of solar incidence are measured by the main spectrometer (center). Simultaneously the Solar X-ray Monitor (SXM) measures the incident solar flux arriving in parallel at both the asteroid and detector. Figure from Inamdar et al. (2014)

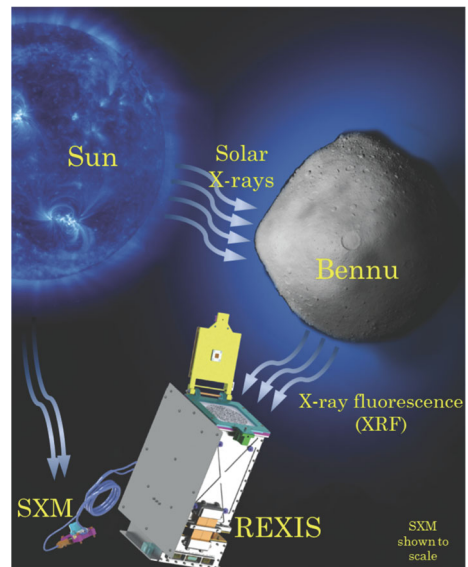

description of the target asteroid and mission profile.) Building on the educational and scientific success of the student calibration experiment (a dust counter; Horanyi et al. 2008) flown aboard NASA's New Horizons mission to Pluto, a competition was held in 2010 to solicit proposals from among educational institutions participating as partners in the OSIRIS-REx Phase A study. Out of a pool of four proposals, the Regolith X-ray Imaging Spectrometer (REXIS) instrument was selected in October 2010 by Michael Drake, the founding OSIRIS-REx Principal Investigator. Upon selection, REXIS was invited to the Phase A Concept Study Review (January 2011) and was included as a separately funded instrument when OSIRIS-REx was selected by NASA as the third mission in the New Frontiers program. The REXIS science concept is illustrated in Fig. 1 (with further details in Sect. 2). For its operation, REXIS takes advantage of the natural incident solar X-ray flux that produces a measurable and scientifically diagnostic fluorescence from the asteroid's surface. REXIS joins a lineage of X-ray fluorescence experiments flown in space that can trace a history back to the Apollo era (Adler et al. 1972) through to the first in situ asteroid investigations (Nittler et al. 2001). See Table 1 of Allen et al. (2013) for a more detailed summary.

The design and implementation of REXIS as a Class D student-built instrument is through a partnership between the Massachusetts Institute of Technology (MIT) and Harvard University. Multiple units within MIT are key participants, including the Space Systems Laboratory in the Department of Aeronautics and Astronautics, the Department of Earth, Atmospheric, and Planetary Sciences (EAPS), Lincoln Laboratory, and the Kavli Institute (astrophysics). For Harvard University, REXIS' project participation is through the Harvard College Observatory, a member of the Harvard-Smithsonian Center for Astrophysics.

The REXIS instrument development philosophy follows a stepwise path to flight through three successive models: an Engineering Test Unit (ETU), an Engineering Model (EM), and a Flight Model (FM). The ETU validates the functional capability of the instrument concept. There can be many separate ETUs to test the functionality of major subsystems. The EM refines fabrication, integration, and environmental test procedures. The EM ensures fit along with functionality and tests interfaces. Finally, the FM is the deliverable to the spacecraft, with significant components having identical spares developed in parallel for

possible replacement in the FM, or for ongoing laboratory testing to support the hardware during flight. The REXIS detector assembly, detailed in Sect. 2.2, is one such example of this parallel development.

The educational organization of the REXIS project began through the Conceive, Design, Implement, and Operate (CDIO) curriculum at MIT (Crawley et al. 2007). The CDIO curriculum is cross-listed between the Department of Aeronautics and Astronautics and EAPS and is open to Harvard students for credit. The goal of CDIO is to immerse undergraduate and graduate students in the professional process of developing aerospace systems through requirements flow down, design, fabrication, test, and operations while documenting and communicating their progress to faculty and external reviewers. The CDIO class developed the requirements for the REXIS instrument, participated in the System Requirements Review (SRR) and the System Definition Review (SDR), and built and exercised a number of ETUs. The instrument design, build, and test phase then transitioned to a graduate research team, but undergraduate support continued through the Undergraduate Research Opportunities Program (UROP). The graduate team built and tested the EM, completed all necessary milestone reviews including the Preliminary Design Review (PDR) and the Critical Design Review (CDR), built the flight instrument, and executed the instrument integration and test program. Long-term project continuity was achieved by phasing in new students before advanced students graduated and by assigning senior mentors (faculty and research staff) to each subsystem team.

1.1 Overview of REXIS Science Objectives

REXIS has two primary science objectives: (I) measure the target asteroid Bennu's elemental abundance properties and determine its context within known meteorite groups and (II) map the spatial distribution of elemental abundances on the surface of the asteroid so as to help inform sample site selection and/or provide localized context for the sample. These objectives (described in detail by Allen et al. 2013 and Jones et al. 2014) complement other OSIRIS-REx instruments that deliver mineralogical maps of Bennu through visible and near-infrared spectroscopy. Over the soft X-ray energy range of 0.5 to 7 keV, REXIS seeks to measure fluoresced lines in the Fe-L, Al-K, Mg-K, S-K, and Si-K complexes. (See Allen et al. 2013 for more details.) As illustrated in Fig. 1, these fluoresced lines are the result of stimulated emission created by the impinging solar X-ray flux. To accomplish scientific objective (I), REXIS must measure the global elemental abundance ratios of Fe/Si, Mg/Si, and S/Si with an accuracy of $\leq 25\%$, where the design encompasses (but is not limited to) the anticipated conclusion that Bennu will fall within the broad realm of carbonaceous chondrite meteorites. Thus the measurement objectives and scientific success of REXIS rest upon the foundation established by laboratory measured elemental abundance ratios of meteorites, most extensively conducted and reported by Nittler et al. (2004). These meteorite data, in particular the Mg/Si and S/Si ratio laboratory measurements, are diagnostic to allow further classification within the CI, CM, and CV subgroups of carbonaceous chondrites, as shown in Fig. 2.

To accomplish objective (II) at the highest possible spatial resolution, REXIS utilizes a coded aperture mask (having a 50% open fraction) enabling the reconstruction of resolved maps of the asteroid's surface. The openings within the mask act in a similar manner to a pinhole camera, where the many pinholes increase the overall X-ray throughput. As described in Sect. 3.3, the shadow pattern of X-rays (with their individual energies) projected by the mask onto the area detectors (described in Sect. 2.2) are back-projected onto the asteroid using knowledge of both the mask pattern itself and the spacecraft's pointing for

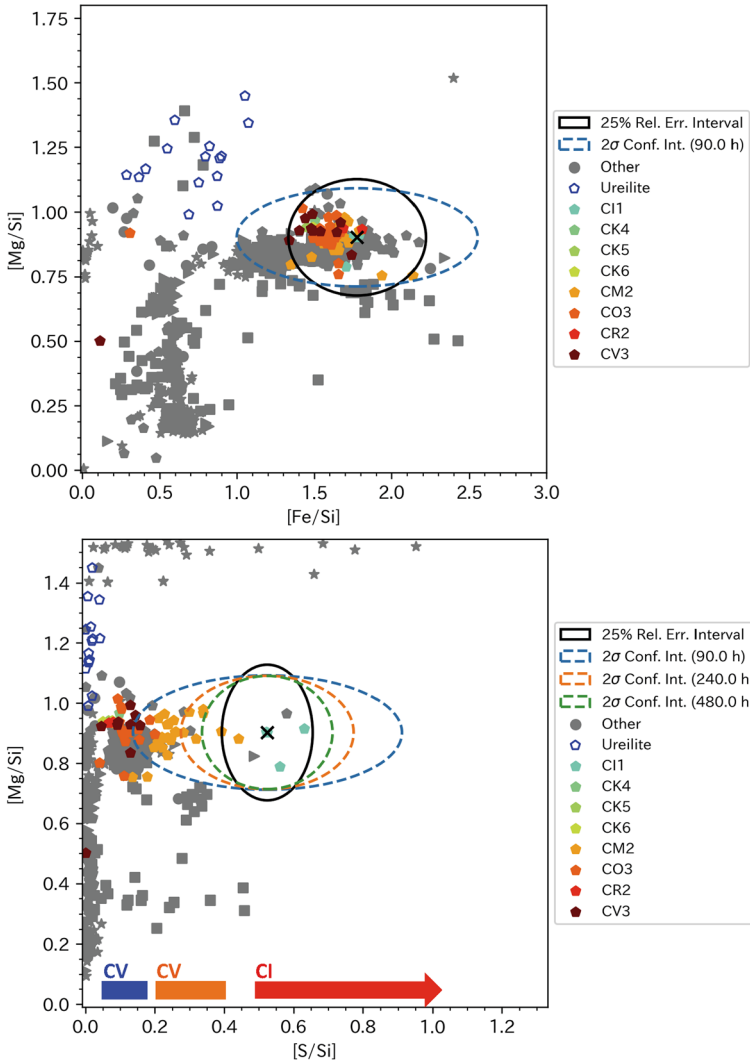

Fig. 2 Ground-based telescopic observations have shown Benu to most closely resemble a C1 or CM chondritic meteorite. Two objectives of REXIS measurements are to (a) determine whether or not Benu is indeed a chondrite, and to (b) determine which type of chondrite based on observations of sulfur. The expected performance and requirement values are shown in the *above plots* for REXIS as *dashed and solid lines*, respectively. For the case of S, progressive improvements in measurement precision are shown for integration times increasing from 90 h to 480 h. The measurements of the elemental abundance ratios for the individual meteorites were carried out in the lab; meteorite data shown are from Nittler et al. (2004)

each 4-second integration. Repeated imaging of Benu’s entire surface (enabled by both spacecraft orbital motion and the asteroid’s rotation) allows for co-adding the mapping images for increased spatial resolution and higher signal-to-noise ratio elemental abundance measurements. For significant heterogeneity of Benu, REXIS has the anticipated capability to reveal (for example) a localized 4× enhancement of iron in the regolith with 50-meter spatial resolution.

All of the measurement and science objectives for REXIS are derived from the instrument performance that is expected for minimum solar X-ray flux; OSIRIS-REx will operate at the asteroid target near the minimum in the solar cycle. Even at solar minimum, an accounting must be made for the variability of both the overall solar flux and its spectral energy distribution. (The total flux and spectral energy distribution during solar flares changes over timescales as short as a few minutes.) To obtain knowledge of the solar flux arriving at the asteroid, the REXIS instrument also includes a secondary sensor pointed toward the Sun called the Solar X-ray Monitor (SXM; see description in Sect. 2.5). An overview of the solar state modeling enabled by the SXM data and its application to the final data processing is provided in Sect. 3.3. Much more extensive details of the solar state modeling are described by Allen et al. (2013).

Table 1 of Allen et al. (2013) details the comparison of REXIS to previous X-ray fluorescence experiments flown or scheduled to be flown. Most applicable is comparison to the instrument flown aboard the Near-Earth Asteroid Rendezvous Mission (NEAR; see Goldsten et al. 1997 for that instrument description). Relative to NEAR, REXIS operates over a wider energy range (0.4–7 keV versus 1.5–5.5 keV) with finer spectral resolution (~ 150 eV versus ~ 800 eV at 5.9 keV). REXIS integrates over a much wider field of view (30 degrees versus 5 degrees). In addition as we describe here, the use of Fe-55 calibration sources onboard REXIS enables continuous monitoring of the detector gain and resolution. The use of back illuminated CCDs gives a lower energy threshold for REXIS compared to previous flight instruments, making available lower energy lines such as O-K (0.525 keV) and Fe-L (0.792 keV), which are more readily measurable during the quiet solar states (A3–A4) expected during the time of OSIRIS-REx asteroid operations.

2 REXIS Instrument Overview

The REXIS instrument consists of two assemblies: the main spectrometer for measuring the asteroid's surface and the solar X-ray monitor, as shown in Fig. 1. The main spectrometer consists of three major subassemblies (shown in detail in Fig. 3): an electronics box that houses the electronics boards, a tower that acts as a telescope support and contains the detectors, and a mask assembly that includes the coded aperture mask and a deployable cover. The flow of data and power through the REXIS instrument is shown in the functional block diagram in Fig. 4. Power from the OSIRIS-REx spacecraft is conditioned in the electronics box and then distributed within the main spectrometer and separately to the SXM. The spacecraft additionally provides a power connection to the REXIS cover heater for the purpose of keeping the deployment mechanism warm even when REXIS is not powered on. REXIS science and housekeeping data are processed in the electronics box and sent to the main spacecraft over an RS-422 data connection.

The electronics box has a footprint of approximately 14.2×20.0 cm and is mechanically and thermally coupled to the instrument deck of OSIRIS-REx. The electronics box (described in Sect. 2.3) houses three electronics boards: the Main Electronics Board (MEB), the Interface Board, and the Video Board. The MEB interfaces with the spacecraft, regulates power for the other boards, and contains the main processing unit. The Video Board drives the detectors and converts the analog detector signal to a digital signal for transmission to the Interface Board. The Interface Board converts the digitized detector data to Camera Link format and sends it to the MEB for processing. The Interface Board also controls detector housekeeping data collection.

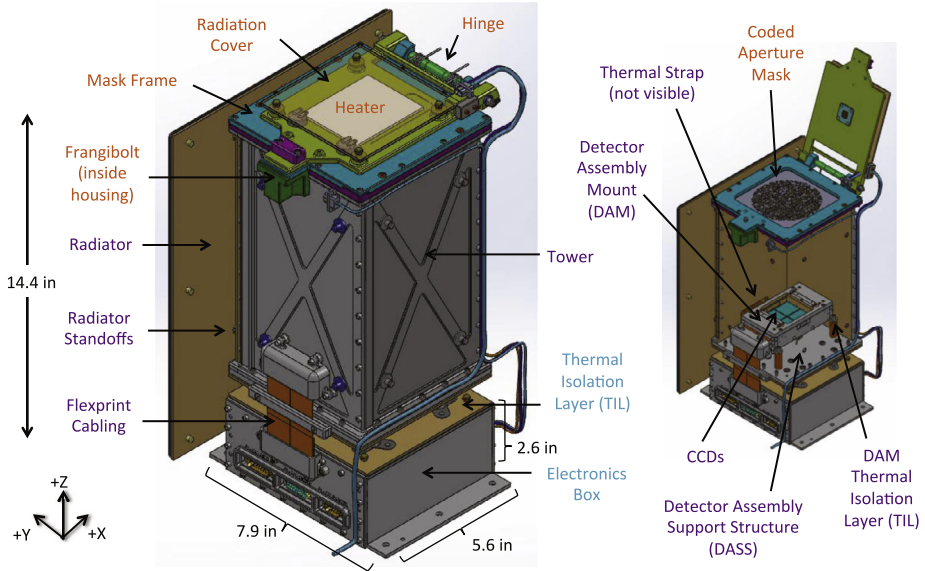

Fig. 3 Detailed views of the REXIS main spectrometer. The spectrometer subassemblies are grouped by color

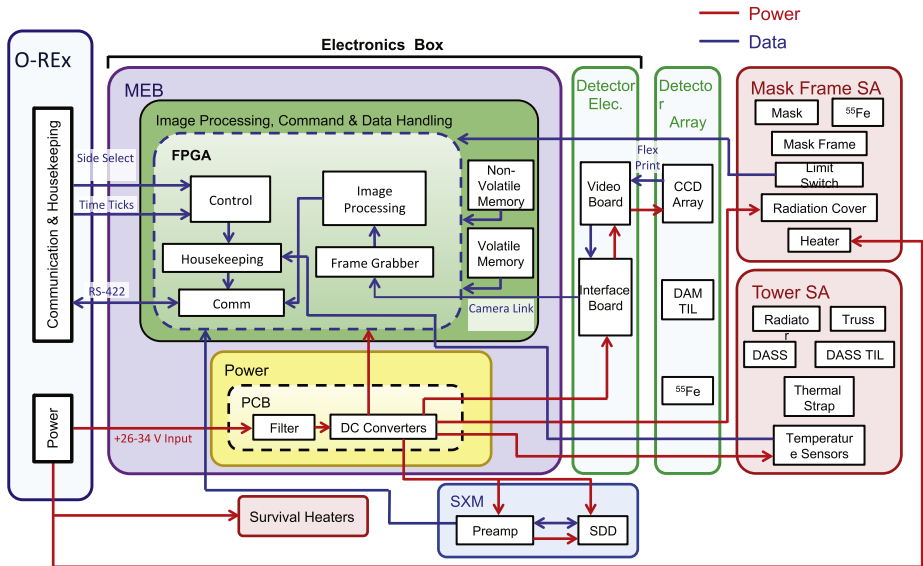

Fig. 4 Functional block diagram for REXIS illustrating the power and data interface with the OSIRIS-REx spacecraft and the onboard processing

The REXIS tower is connected to the electronics box via four titanium standoffs. The tower itself consists of the detector assembly support structure (DASS) and four aluminum truss panels coated with 4 μm of gold that shield the detectors from X-ray fluorescence emit-

ted by the instrument structures through their own interaction with the cosmic background radiation. The spectrometer detector plane is comprised of a 2×2 array of back-illuminated charge-coupled devices (CCDs) (described in Sect. 2.2) within the detector assembly mount (DAM). The DAM is connected to the DASS via four Torlon 5030 standoffs. The tower supports the mask assembly 20 cm above the detector array, creating an effective focal length of 20 cm for the X-ray telescope.

The mask assembly consists of the radiation cover and its deployment system (described in Sect. 2.4), the coded aperture mask (described immediately below), and the mask frame. The radiation cover shields the detectors from radiation to prevent degradation during the cruise to Bennu. As described in Sect. 2.4, the cover is opened after arrival at the asteroid through the actuation of a TiNi FD04 Frangibolt.

REXIS is the first planetary surface mapping X-ray spectrometer to employ a coded aperture mask, where the mask consists of a random pattern of holes (1.536 mm squares) with an overall 50% open fraction. The REXIS design decision to employ a coded aperture imaging was based on the potential for this method to deliver a combination of high throughput and high angular resolution imaging over wide-fields of view. The coded aperture technique has been developed and used for X-ray (and particularly hard X-ray) surveys for point sources within wide fields of view (typically ~ 10 – 70 degrees), as described by Skinner (2008). The advantage of coded aperture imaging over an instrument with a 1-D collimator operating in a linear scanning mode is that the two dimensions of the CCD detector plane allow an immediate 2-D image position to be derived and enable imaging a landscape that is moving due to both S/C orbital motion and asteroid rotation under changing solar illumination conditions. Combining 1-D collimator scans accumulated over these changing conditions would result in significant loss of sensitivity. Although coded aperture imaging has not been used for mapping extended sources and regions whose scale is a priori unknown, REXIS has the ability to localize and map regions with enhanced concentrations of fluorescing elements through the basic principles of geometric optics as described in Sect. 3.3 (if such concentrations of Fe, Mg, Si or S happen to be present).

2.1 Engineering Performance Driven by Science Requirements

The science objectives for REXIS described in Sect. 1.1 drive the overall design parameters as summarized in Table 1. For science objectives (I) and (II), the key driving requirements are the spectral energy resolution of the REXIS detectors and sufficient integration time to build up the necessary signal-to-noise ratio. The energy resolution requirement is set at a full-width at half-maximum (FWHM) value of <260 eV at 5.9 keV. More details on this requirement are found in Jones et al. (2014).

Detector background noise arises from thermally generated dark current, charge transfer inefficiency (CTI), charge splitting, measurement uncertainties in CCD bias level, as well as noise introduced by the CCD readout electronics. Dark current is produced when charge carriers are thermally excited from the valence band to the conduction band in the CCD's active silicon volume and decreases with decreasing temperature. CTI accounts for inefficiencies in moving the collected electrons from their original pixel location to the readout electronics. In the case of space hardware, CTI can be expected to worsen (increase) with increasing exposure to radiation in the space environment (Grant et al. 2004). Dark current and CTI are functions of the physical state of the detector, and REXIS seeks to mitigate their effects through engineering design that includes thermal control (Sect. 2.6) and a radiation cover (Sect. 2.4). Given all these factors and their measured values, integration times on Bennu to meet the REXIS science requirements were determined.

Table 1 Parameter summary for the Regolith X-ray Imaging Spectrometer (REXIS) instrument

Physical Parameters	
Total Mass	6.5 kg
Total Power	12.4 W
Focal Length	20 cm
Detector Plane	2 × 2 CCDs
Active Area	24.159 cm ²
FOV	27.6° (FWHM)
Angular Resolution	26.2' (5.6 m @ 730 m)
CCD Parameters	
Type	MIT-LL CCID-41
Energy Resolution	<260 eV @ 5.9 keV
Energy Range	0.5–7.0 keV (QE ≥ 0.3)
Pixels	1024 × 1024
Pixel Dimensions	24 μm × 24 μm
Active Area	6.03880 cm ²
Depletion Depth	45 μm
Optical Blocking	320 nm Direct Deposited Al
Operating Temperature	≤ −60°C
Mask Parameters	
Thickness	100 μm
Composition	ASI-301 Stainless Steel
Pattern Diameter	98.304 mm (64 Pixels)
Open Hole Fraction	0.5
Pixel Pitch	1.536 mm
Support Grid Width	100 μm
Solar X-Ray Monitor (SXM)	
Detector	Amptek XR-100 SDD
Active Area	5 mm × 5 mm
Energy Range	1–20 keV
Energy Resolution	<200 eV @ 5.9 keV
Depletion Depth	500 μm
Optical Blocking	0.5 mil Be Window
Operating Temperature	≤ −30 C

Measurement of the spectral energy distribution of the impinging solar X-rays is also critical for achieving the science requirements, because knowledge of the incident solar X-ray flux must be available for proper calibration and interpretation of the asteroid measurements. The SXM energy resolution achieved is FWHM <600 eV for incident photons at 5.9 keV. Section 2.5 discusses the engineering design to achieve this performance.

2.2 Detectors and the Detector Assembly Mount (DAM)

The REXIS main spectrometer employs a detector array consisting of 4 MIT Lincoln Laboratory CCID-41 charge-coupled devices (CCDs) in a 2 × 2 array. The choice of the

CCID-41s was based on their availability and their flight heritage aboard the Suzaku mission launched in 2005. At the time of the REXIS conceptual design, the CCID-41s were assessed to provide a favorable combination of effective area, spectral resolution and spatial resolution that could deliver science measurements supporting the OSIRIS-REx mission objectives. Internal expertise and the opportunity to use an existing stock of detectors greatly reduced cost and enabled a REXIS construction schedule that fit within the assembly and test timeline for a mission constrained by a fixed launch date. As detailed by Ryu et al. (2014), a CCID-41 is a three-layer polysilicon CCD with an n-type buried channel with a depletion depth of 45 μm to enable high quantum efficiency (QE) for 0.3–10 KeV X-rays. The CCDs are fabricated on high-resistivity (>3000 Ohm-cm) float-zone wafers with impurities less than 0.1 ppb that enable deep depletion depth. Each CCID-41 includes a 1024×1024 imaging array of 24- μm pixels arranged in four separate output nodes and accompanied by a nonimaging frame storage region. The CCDs are back-illuminated (i.e. the CCD electrical layers are deposited on the surface opposite to the side that is exposed directly to the arriving X-rays), thereby increasing overall performance particularly for lower-energy X-rays. Our choice of back illumination as a means for increasing sensitivity at low energies has flight heritage tracing to the Suzaku XIS and Chandra ACIS-S detectors (LaMarr et al. 2008; Plucinsky et al. 2017). Rejecting visible light is also critical to our detector performance; thus the REXIS detectors use a 320-nm-thick aluminum layer optical blocking filter (OBF) directly deposited on the CCD surface. REXIS is the first instrument to fly CCID-41 detectors with a directly deposited optical blocking filter (Ryu et al. 2014). To enable the data output, the REXIS CCDs are electronically connected to the Video Board in the electronics box via four flexprint cables. Two of these flexprint cables were partially torn due to improper handling during a post-vibration test inspection of the instrument. A staking material, Arathane, was applied to the affected flexprint cables to protect against further tearing. However, functional operation of 4 of the 16 nodes in the REXIS detector plane were irrevocably lost due to the incident. Two other nodes began showing unusually high noise characteristics during environmental testing. When launched REXIS had 10 out of 16 nodes performing as expected.

As described by Bralower (2013), each CCD is mounted on a ceramic substrate that connects it to the detector assembly mount. The DAM serves to align, calibrate, and protect the detector array. Once the detectors are mounted and aligned, the DAM itself is integrated within the REXIS tower assembly. The walls of the DAM, along with all other parts of the instrument that view the detectors, are coated with 4 μm of gold to attenuate the fluorescence of the aluminum structure so that an internal aluminum line emission is not imposed on the collected asteroid signal.

Monitoring and calibrating the sensitivity (and long-term performance) of each CCID-41 is accomplished using several ^{55}Fe sources mounted in the DAM; these are shown in Fig. 5. The source positions are chosen to illuminate only small portions of each CCD. Eight ^{55}Fe sources illuminate the boundaries between the nodes of each CCD, and two ^{55}Fe sources illuminate the boundaries between the abutting CCDs. One additional ^{55}Fe source is located at the very top of the REXIS instrument, held in place during the cruise phase on the inward-facing side of the radiation cover (Sect. 2.4). Through this arrangement, pixels reading out through each CCD node receive X-ray photons of a known energy, thereby enabling the measurement and long-term monitoring of the gain and spectral resolution of the detectors. An added measure of the detector health and performance is achieved by comparing the energies of the photons received from the side sources with the energy of the photons received most directly on the detectors from a source placed on the cover. This comparison enables characterization of the CTI, with particular attention to its degradation over time

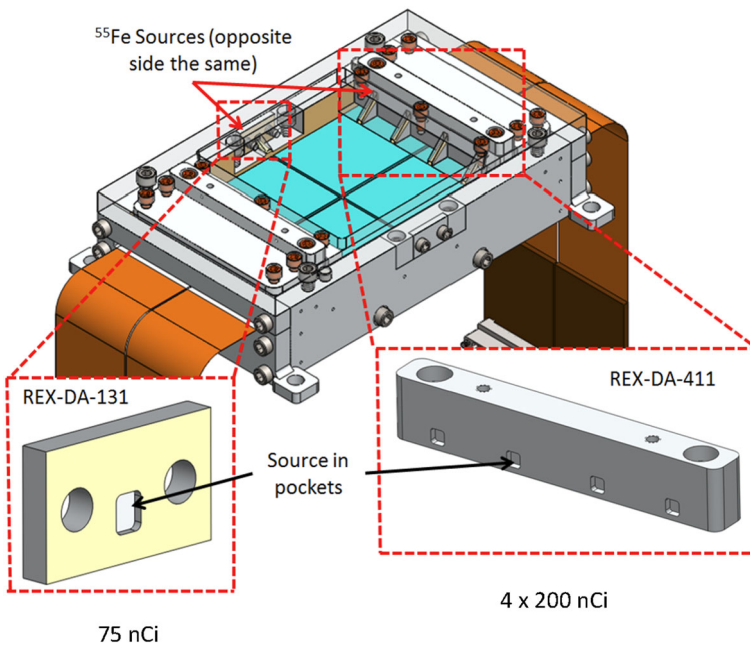

Fig. 5 Illustration of the detector assembly mount (DAM) showing the placement of the onboard calibration sources. The DAM houses two side holders (REX-DA-131), each with one 75 nano Curie (nCi) ^{55}Fe source, and two top holders (REX-DA-411), each with four 200 nCi sources. The two types of holders along with collimators allow for placement of the calibration spots such that all sixteen CCD output nodes are illuminated with 5.9 keV X-rays at all times. Note that the DAM is symmetric and the four CCDs are the same size; the illustration is a side-angle view

due to background radiation damage. When the cover opens, the radiation source mounted on the cover is removed from the field of view (FoV) of the detector array, and the ^{55}Fe illumination becomes limited to the small portions of each CCD from the sources mounted along the outside edges of the arrays, thereby preserving the majority of the CCD area for X-ray flux measurements from the asteroid.

2.3 REXIS Electronics Box

In Fig. 3, the REXIS electronics box is shown below the DAM where it is thermally isolated from the detectors (Sect. 2.2). In general electronic parts were chosen to balance radiation tolerance and cost. Given the modest budget and high risk tolerance of a student instrument, it was not possible to build with exclusively radiation-hardened parts and stay within programmatic constraints. Therefore, the REXIS approach to part selection considered system-level radiation tolerance and utilized test data from other programs as much as possible (Biswas 2016). The REXIS avionics stack, contained within the electronics box, consists of the Main Electronics Board (MEB), the Video Board and the Interface Board as shown in Fig. 6. The MEB was designed and laid out by the REXIS students and serves as the interface with the spacecraft. It contains the main processing unit, a commercial radiation-tolerant Xilinx Virtex 5 field programmable gate array (FPGA). The Virtex 5 controls the operation of REXIS, processes the raw X-ray CCD images and provides the communication link with the main OSIRIS-REx spacecraft. The Virtex 5 FPGA was chosen due to the need

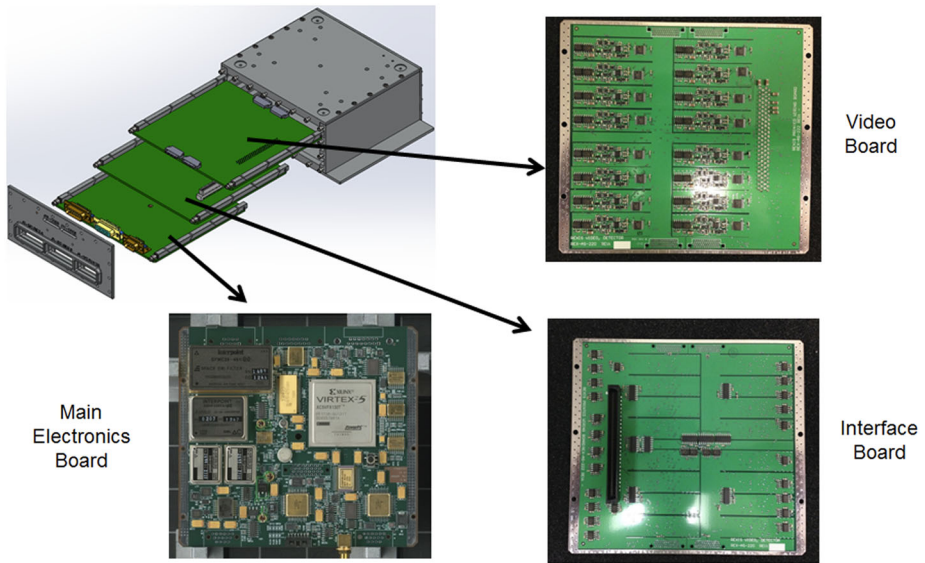

Fig. 6 Drawing of the REXIS electronics box showing the three-board stack along with photos of the EM boards

to provide on-board image processing and radiation tolerance as well as a desire for being reconfigurable (Schmidt 2013). The MEB also contains the power regulation and distribution system, as well as the SXM analog signal processing electronics (pulse shaping and trigger circuits). The Video Board and Interface Board together are known as the Detector Electronics (DE). The design of the REXIS DE and part selection is based largely on early prototypes of the Detector Electronics for the Transiting Exoplanet Survey Satellite (TESS) mission (Ricker et al. 2014). The Interface Board includes a radiation tolerant Actel FPGA. The Video Board receives and digitizes the raw CCD images before passing these data to the Interface Board. The role of the Interface Board is to convert the digitized data from the Video Board to Camera Link format for transmission to the MEB. The Interface Board also controls the housekeeping data collection for the detectors. An important design consideration for the electronics box is its role serving as a benign structural and thermal environment for the boards. Radiation shielding is also a key design factor, where the walls of the electronics box are 0.32 cm thick, shielding the electronics from low-energy solar protons. The electronics boards are each 14.0×15.2 cm and are connected to the walls of the electronics box using wedgelocks that provide a stiff structural connection and good thermal conductivity from the boards to the walls. Details on the early design of the REXIS MEB and Detector Electronics can be found in Schmidt (2013), while details of the final design including the FPGA core can be found in Biswas (2016).

2.4 REXIS Mask Assembly and Radiation Cover

At the telescope aperture entrance at the top of the REXIS instrument there resides an assembly consisting of the coded aperture mask, the mask frame, and a one-time deployable radiation cover. The coded aperture mask includes a 9.84-cm-diameter circular pattern of 1.536-mm square pixels on a substrate of 100- μ m-thick stainless steel, as shown Fig. 7. A support grid 0.15 mm wide runs between all the mask pixels to provide sufficient strength

Fig. 7 Coded aperture mask for REXIS consisting of a random array of 1.536-mm square open pixels, where the overall open fraction of the mask is 50 percent. The mask pattern produces a shadow pattern onto the detector array, enabling the Imaging Mode mapping of the asteroid surface. Radiation cover is shown in the open position, where the inset at cover center holds the cover radiation source used for calibration during the mission cruise phase

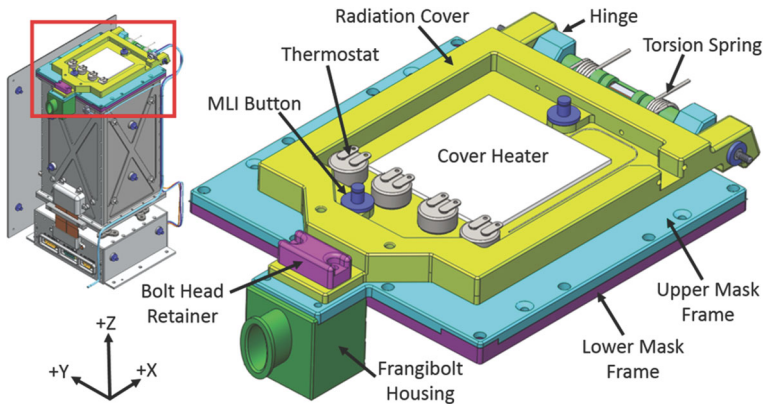
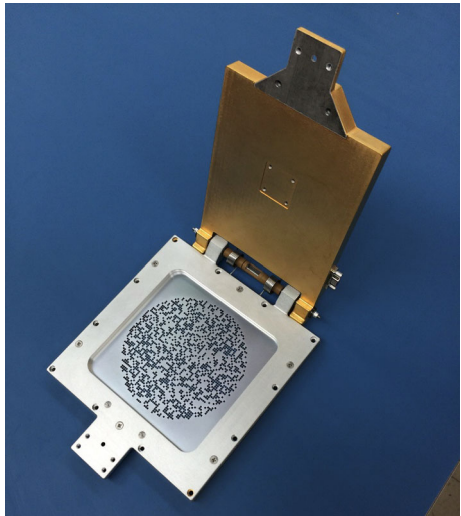
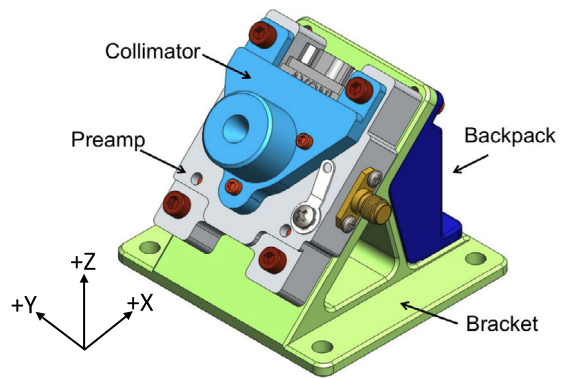

Fig. 8 The REXIS radiation cover is the only moving part, opened once after arrival at the asteroid using spring torque released by actuating the Frangibolt. Cover is shown here in its closed configuration for cruise

and rigidity for the mask to survive launch stress. The mask pattern is random, with an open fraction of 50%. A layer of SiOx (2 μm in thickness) coats the external surface of the mask to minimize thermal stress during mission phases where sunlight may fall directly on the mask. Any possible Fe fluorescence originating from the stainless steel itself is attenuated by a 4- μm gold layer deposited on the bottom surface of the mask. The mask is clamped between two aluminum frames to provide long-term stability and keep it in alignment with the detector plane without deformation throughout all science operations.

REXIS employs a deployable radiation cover, shown in Fig. 8, which consists of a 4-mm-thick aluminum plate. The cover's purpose is to provide maximum protection from radiation damage for the CCID-41 detectors prior to performing their scientific measurement objectives at the asteroid. Thus the cover is kept closed during the cruise phase to Bennu. The one-time deployable radiation cover is the only moving part on the REXIS instrument. (See Carte et al. 2014 for an in-depth description.) Upon arrival at Bennu, the cover opening is accomplished using a one-time release TiNi Aerospace FD04 Frangibolt actuator. This

Fig. 9 Detailed view of the REXIS solar X-Ray monitor (SXM) showing the SXM collimator, housing, backpack, and mounting bracket. The collimator creates a 42 degree field of view for the SXM and restricts the flux to pass through a 1 mm pinhole on to the detector



actuator is a shape-memory alloy-based mechanism that when heated, elongates and breaks a notched bolt holding the cover closed. The impulse due to the breaking of the bolt and the torque provided by torsion springs around the hinge of the cover provide the force necessary to open the cover. Verification of the opening of the radiation cover is provided by a custom TiNi switch washer that sends a signal to the MEB to terminate the power supplied to the Frangibolt. For redundancy, a backup timer is also set to cut power to the Frangibolt if the opening of the radiation cover is not detected within the expected time. Once released, the cover is held in its fully open position against hard stops by the torque provided by the torsion springs on the hinge.

Operational considerations for the REXIS cover deployment include the fact that the cover mechanism remains closed for the 2.5-year cruise to Bennu. Therefore, sources of friction and stiction are minimized between the cover and the mask frame. For example, in the closed state the cover does not touch the mask frame except around the Frangibolt fastener and at the hinge. Any chances of stiction or cold welding are further minimized through a Teflon-impregnated anodization coating on the mask frame around the Frangibolt. The cover hinge consists of a stainless steel shaft with Vespel bushings providing low friction between the shaft, the cover, and the mask frame mounts. Additional protection for the stability and reliability of the Frangibolt and the hinge is achieved by maintaining temperature control (keeping them warmer than the tower) through heaters located on top of the cover and on the Frangibolt housing. As described in Sect. 2 and detailed in Fig. 4, the cover and Frangibolt heaters are powered by the main spacecraft and controlled by mechanical thermostats.

2.5 Solar X-Ray Monitor (SXM)

Accurate characterization of the X-ray fluorescence measured from Bennu requires knowledge of the impinging solar X-ray flux and its energy distribution. REXIS therefore employs a solar X-ray monitor (SXM) as a separate unit from the main spectrometer. These separate components are depicted in Fig. 1. The SXM is mounted on a gusset of the OSIRIS-REx spacecraft that is oriented in the sun-facing direction during the observational phases of Bennu. The mechanical interface of the SXM to the spacecraft is through an aluminum mounting bracket. The electrical interface of the SXM connects directly to the REXIS Main Electronics Board through a harness routed along the spacecraft deck. An annotated diagram of the SXM and its collimator are detailed in Fig. 9. Further description of the SXM mechanical, thermal, electrical, and software design can be found in Jones (2015).

The SXM detector assembly consists of an Amptek XR-100SDD silicon drift diode (SDD) with an effective area of about 17-mm². When choosing the SXM detector and considering the electronics design, the REXIS team worked closely with the Neutron star Interior Composition Explorer (NICER) instrument team. The NICER detector packages were developed at MIT using Amptek SDDs (Prigozhin et al. 2016). The REXIS SXM employs the same Amptek SDD as NICER, packaged within a Ni housing that holds in place a 25-mm², 12.7-micron-thick (0.5-mil) beryllium window and a collimator restricting the SXM field of view to 42 degrees full-width maximum intensity (FWMI). The Be window serves the same purpose as the optical blocking filters for the main spectrometer CCDs (Sect. 2.2), rejecting light in the visible spectrum that otherwise presents a source of noise to the X-ray signal. Thermal isolation and control are also essential aspects of the maximum signal relative to thermal noise for the SXM performance and are described in Sect. 2.6. The Amptek package includes an off-the-shelf thermoelectric cooler (TEC) that controls the temperature of the SDD.

The SXM assembly includes two electronic boards: the SXM Electronics Board (SEB) and the SXM Backpack Board (SBB). The SEB design is also based largely on the NICER instrument. It contains the detector preamplifier and the SDD temperature monitoring circuitry. The role of the SEB is to condition and amplify the analog signal before it is sent to the REXIS MEB for processing. The SBB is a separate board that conditions the power for the TEC.

A subset of the SXM electronics also resides on the MEB, specifically the shaping and triggering circuitry necessary to identify X-ray events from the input SDD voltage signal. Proper timing of the event triggers is necessary to determine the height (energy) of each incident X-ray photon. The REXIS triggering circuitry is also based on early NICER electronics. The number and energy of each incident solar X-ray is recorded in a 512-bin histogram, where the scale of the histogram (mathematically) spans approximately from -5.9 keV to 23.6 keV, with a resulting energy scale of 59 eV/bin. The useful energy range for the SXM extends from 1.0 keV up to 23 keV.

2.6 REXIS Thermal Design

The thermal environment for REXIS operation poses design challenges for meeting both science and operational requirements. The resulting design parameters are described in detail by Stout and Masterson (2014). These challenges, summarized from the top of the instrument (as depicted in Fig. 3) and progressing downward, include the following: providing a benign thermal environment for the radiation cover and Frangibolt during cruise and cover opening actuation, maintaining thermal stability of the coded aperture mask to avoid permanent structural distortions whether pointed near the sun or to deep space, cooling the primary detectors of the main spectrometer within their operating range for minimal thermal noise, and keeping the solar X-ray monitor detector within its operating range when pointed toward the sun.

Cooling the main spectrometer's CCID-41 detectors during their operation is the predominant driving requirement for the overall REXIS thermal design. As described in Sects. 2.2 and 2.3, the detectors operate adjacent to the warm electronics box. As a consequence, cooling the CCDs to their -60°C operating temperature requires a 120°C (maximum) thermal gradient between the two components. REXIS achieves this large thermal gradient passively through a two-stage thermal isolation design and a large radiator. This thermal isolation layer (TIL) design is shown in Fig. 10. The first stage of the thermal isolation between the detector assembly mount and the electronics box consists of four cylindrical, hollow, titanium

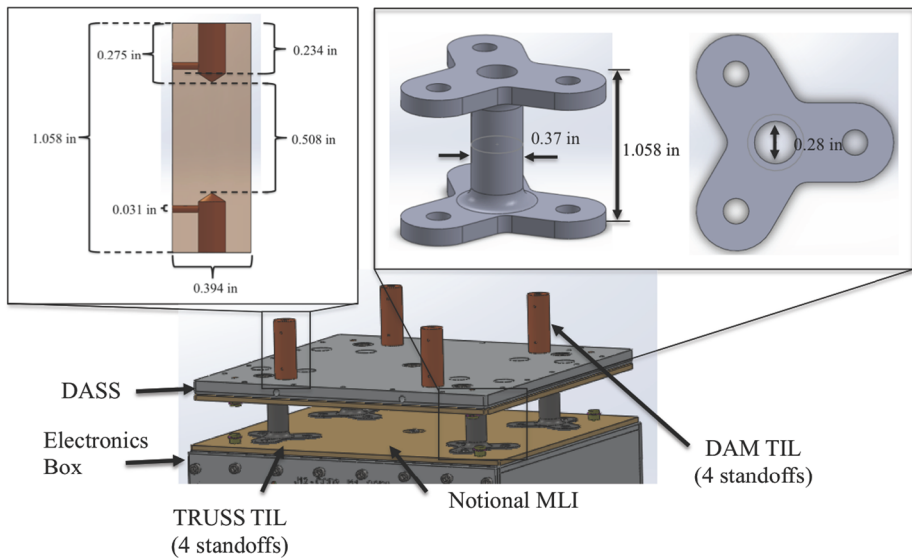

Fig. 10 Detailed view of the REXIS thermal isolation layer (TIL). REXIS employs a two-stage TIL with titanium standoffs between the electronics box and detector assembly support structure and Torlon standoffs between the DASS and the detector assembly mount (DAM) that houses the CCDs

standoffs whose length was maximized and cross-sectional area minimized to the extent permitted by structural requirements for surviving launch stress and vibration. These titanium standoffs themselves support an 80°C temperature gradient between the top of the electronics box and the detector assembly. The second thermal isolation stage is between the detector assembly support structure and the DAM and consists of four cylindrical, solid Torlon 5030 standoffs capable of supporting a 40°C temperature difference.

The final components in the passive cooling system include a copper thermal strap that runs between the DAM and a large radiator with a view of deep space. Dissipation of REXIS electronics box heat is primarily through the physical interface with the spacecraft. The electronics box is conductively coupled to the spacecraft deck so that heat generated by the electronics is carried away by the spacecraft structure. However, there is some parasitic heat that makes its way from the electronics box to the detectors through the thermal isolation layers. In addition, there is some heat generated by the detectors themselves during operation. The copper thermal strap moves this residual heat away from the DAM to achieve the cold temperatures needed to generate meaningful science data. The copper thermal strap has a conductivity of over $0.5\text{ W}/^{\circ}\text{C}$ and is 9.2 cm long. Both ends of the thermal strap use indium foil as a gap filler to reduce the contact resistance between the thermal strap and the radiator, as well as between the thermal strap and the detector assembly mount. The radiator itself is a 32×25 cm flat plate designed to be oriented toward deep space during science operations. The plate's exterior is coated with Z93C55 white paint to maintain a minimum intrinsic temperature (if exposed to sunlight) and therefore most effectively emit heat. The back of the radiator is wrapped in multi-layer insulation (MLI) to radiatively isolate it from the warmer spectrometer side panels. The radiator is mounted to the REXIS tower using stainless steel standoffs. The stainless steel standoffs have a low enough thermal conductivity to support a temperature gradient between the tower and the radiator but a high enough

thermal conductivity to partially cool the tower, minimizing radiative heat transfer back to the detectors.

Thermal control of the solar X-ray monitor is crucial to optimal low-noise performance of its silicon drift diode detector. During operations, the SDD must remain below -30°C in order to achieve the required spectral resolution to characterize and monitor variation in the solar flux and energy distribution. Most of the required temperature gradient is achieved by a two-stage thermoelectric cooler (TEC) included in the Amptek package that is located directly below the detector, thereby providing active cooling. The TEC is capable of providing up to a 90°C temperature difference between the SDD and the XR-100SDD base-plate. In addition, the thermal design for the SXM includes CHO-THERM 1671, a thermally conductive and electrically insulating elastomer, which is used as a thermal gap filler at the mechanical interfaces. One piece of CHO-THERM is placed at the interface between the SDD and its housing to maximize the efficiency of the spacecraft as a heat sink for the SDD. Finally, additional thermal isolation of the SXM is provided by MLI blankets covering all exposed surfaces, except (of course) the SDD aperture receiving the incoming flux.

3 REXIS Mission Operations Overview

3.1 REXIS Checkout, Calibration, and Orbital Operation

The OSIRIS-REx spacecraft was launched on September 8, 2016 and at this writing is about half-way through its 2.5-year cruise phase to Bennu. The REXIS radiation cover remains closed, but checkout measurements monitoring the health and performance of the instrument made using the internal sources occurred shortly after launch and have continued at 6-month intervals during cruise. At the time of this writing, the most recent checkout and calibration occurred just before and after the Earth Gravity Assist (EGA). During this mission phase, the REXIS instrument was on for more than ten hours of observation time and spacecraft maneuvers were executed to enable calibration of the solar X-ray monitor performance across the detector field of view through direct comparison of SXM results with dedicated solar monitor satellites at Earth. During all checkouts, one full CCD frame download is executed to provide detector diagnostics. Accounting for packet overhead, a full raw frame requires passing >8 MB of data through the downlink.

REXIS will have an extended internal calibration period after arrival at the asteroid and before the radiation cover is opened. The radiation cover is opened during the detailed survey phase of the mission. Once the cover is open, the first external observation for REXIS verifying its view of space will be a 3-hour (total integration time) measurement of the Cosmic X-ray Background (CXB), with the spacecraft pointing REXIS to a region of blank sky devoid of bright cosmic X-ray point sources, to provide an initial measurement of the detector response to a known diffuse background spectrum. This activity also provides an instrumental measure of the CXB that will be incident on REXIS from sky regions beyond the limb of Bennu. Calibration of the effective detector area and the alignment of the coded aperture mask will then be accomplished with a 2-hour observation of the Crab nebula (the bright “standard” source for calibration of X-ray telescopes). Asteroid observation operations are planned for a total of 452 hours from an altitude of 700 meters above Bennu’s surface during the mission phase labeled as “Orbital B.” Nominal REXIS operations conclude with a final observation of the Crab nebula that serves as a calibration relative to the first measurements, thereby having “bookend” measurements that characterize any trends in

changing instrument performance throughout the science measurements. The SXM operates continuously throughout all science observations.

The baseline orbital configuration for REXIS science measurement operations is from a terminator orbit. REXIS has a much wider field of view (30 degrees compared to 5 degrees) than the X-ray spectrometer flown aboard NEAR (Goldsten et al. 1997), giving REXIS access to the entire illuminated limb at the designed operational altitude of 700 meters. With this wide field of view, REXIS X-ray photon collection is relatively robust to spacecraft pointing that is offset from true nadir. Given the low reflectance angles, the science data collection over 452 hours is necessary to meet the science requirements. Since the asteroid spin period and OSIRIS-REx orbital period are 4 hr and about 24 hr, respectively, the 4 sec time tag of each X-ray photon is sufficient to generate the probability map of the photon origin on the asteroid surface within a few meters scale.

3.2 REXIS Onboard Data Processing

Detailed descriptions of REXIS onboard data processing are given by Allen et al. (2013) and by Jones et al. (2014), and the details of the implementation in firmware and software is given by Biswas (2016). In order to meet mission data volume requirements, the CCD frames are processed on board the REXIS instrument, and only lists of X-ray events are downlinked to Earth. The REXIS onboard processing pipeline begins with incident photons arriving at the detector array and ends with science and housekeeping packets being transferred to the main spacecraft computer for downlink to Earth. X-ray events on the detectors deposit charge in the respective pixel where they arrive. The nominal exposure time for collecting X-ray events for each REXIS science frame is 4 seconds. At the end of each CCD exposure the charge from each pixel is quickly (10 ms) transferred to a nonimaging framestore area of the detector before it is read out by the slower detector electronics. Once cleared of the previous frame, the imaging area of the detectors begins the next image integration time while the framestore region is read out serially into a single large array by a 12-bit analog to digital converter (ADC). These data are put through a four-step process that includes frame processing, event grading, event filtering, and science packet formation. The final science packet that is sent back to Earth includes an X-ray event list giving the pixel location, energy, and grade of each detected X-ray photon of interest. A full flowchart for the REXIS Image Processing Pipeline is shown in Fig. 11.

As a first step in the onboard data processing, a bias map is generated. The role of the bias map is to account for the contribution from detector noise and dark current that affects each pixel. The bias map is created when REXIS enters science mode and can be regenerated by command if necessary. The bias map is constructed out of 10 image frames, each having a 4-second integration time. The detector noise and dark current of each pixel is estimated from the median value over the 10 frames.

For the second step of frame processing, an X-ray event list is generated for each single frame. Within this list, the value of each pixel is corrected for readout electronics drifts and its bias value according to the bias map for all pixels in the array. Known bad pixels (resulting from charge traps, radiation damage, or visible light leakage) are discarded from the list based on an uploaded bad pixel mask. The bad pixel mask can be updated after launch to account for changes in the detectors due to radiation damage or other degradation. Finally, each remaining X-ray event is tested as to whether it resides above an adjustable event threshold; those above the threshold are added to a candidate X-ray event list (CXEL).

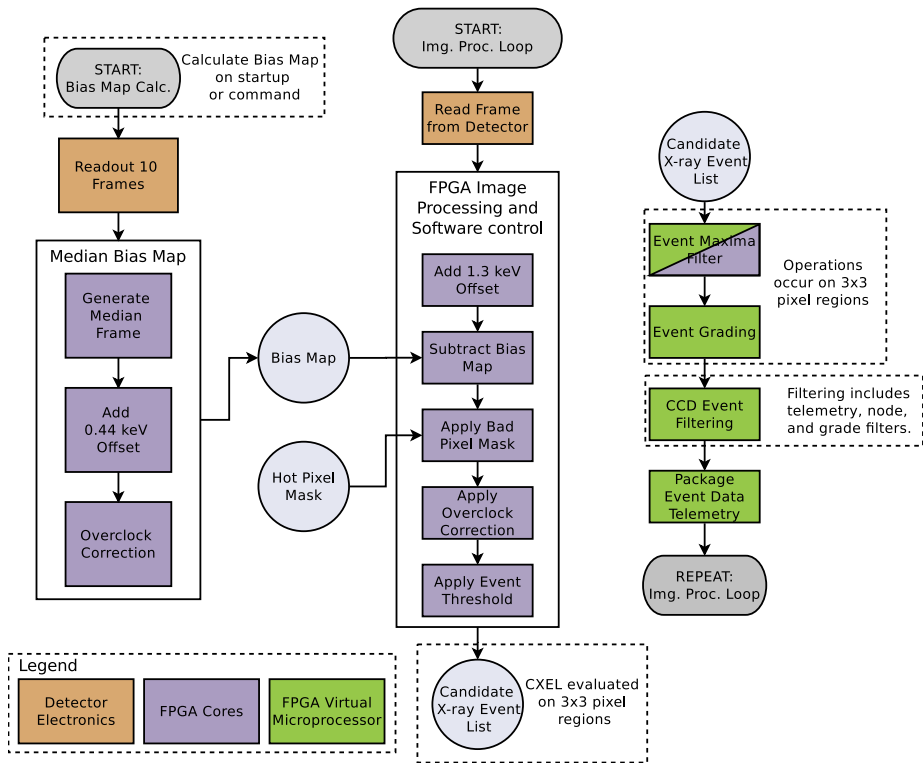

Fig. 11 Flowchart of the REXIS Image Processing Pipeline. In order to meet mission data volume requirements, the CCD frames are processed on board the REXIS instrument, and only lists of X-ray events are downlinked to Earth

The CXEL is fed through an event grading algorithm to identify the pixels that actually correspond to incident X-rays. First, the CXEL is reduced to contain only the pixels with the maximum value from every 3×3 local pixel region in order to prevent double counting of X-ray events when charge is collected across multiple pixels. Each candidate event left in the CXEL is assigned a grade from 0 to 7 that corresponds to how charge from a single incident photon has been divided among multiple pixels. After the event grading algorithm is complete, the flight software creates a histogram of graded events. An event filtering algorithm then ensures that the science data volume does not exceed downlink allocations. A high period of solar activity could result in the event list exceeding the daily downlink allocation for the instrument, in which case the first 1000 (an adjustable parameter) events over the entire energy spectrum are selected to meet the allotment. For a uniform detector response, this selection criterion preserves the shape of the incident energy spectrum and ensures that the final science product remains unbiased. In addition, the total number of events before and after filtering is recorded in order to track the activity of the event filter.

When the final event list is ready, it is packaged for transmission to the spacecraft and eventually back to Earth for post-processing. The science data packet contains the total number of events, the number of saved events, as well as the coordinates, energy level, and event grade of each saved X-ray event. In addition, housekeeping and diagnostic information is collected from the event processing.

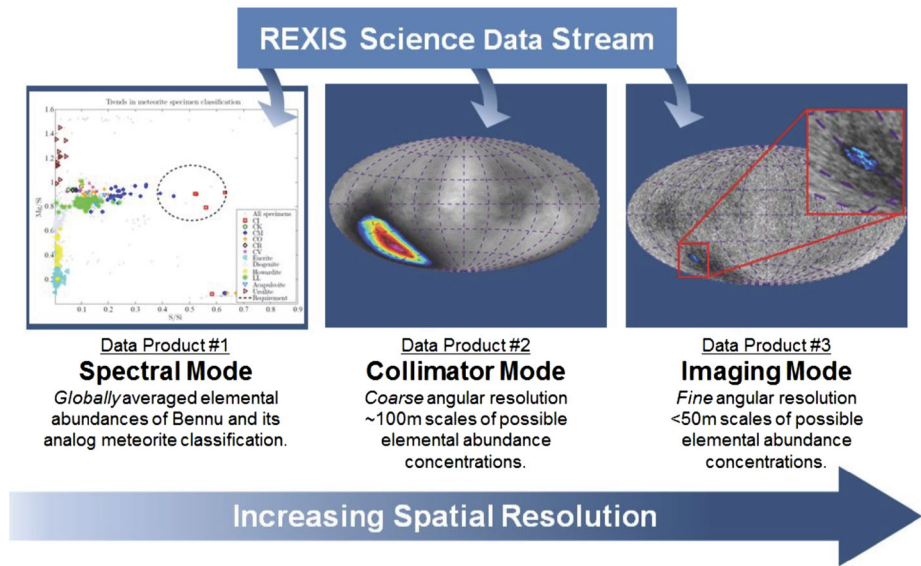

Fig. 12 REXIS produces three science data products, illustrated here. The same REXIS data stream (represented at top) is used in producing each product. All X-ray fluorescence flux from the asteroid is calibrated against the variable solar state, as outlined in Sect. 3.3. REXIS Data Product #1 (Spectral Mode) sums all measured asteroid X-ray photons (regardless of surface location) in order to produce a global average for the entirety of Bennu. These asteroid ratios are directly comparable to elemental abundance ratios for meteorites, where the Spectral Mode illustration displays laboratory measurement reported by Nittler et al. (2004). Product #2 (Collimator Mode) sums all asteroid X-ray photons within the full REXIS field of view, where knowledge of the cartography of the imaged region is derived from spacecraft pointing knowledge. (Precise pointing knowledge is delivered post-facto to the data collection.) Because the full field of view is integrated, Collimator Mode is limited to ~100 m in its spatial resolution. Product #3 (Imaging Mode) takes advantage of knowledge of the coded aperture mask pattern which produces a changing shadow pattern across the detector plane for any localized intense fluorescence source. Section 3.3 outlines this cross-correlation method, which when combined with the spacecraft pointing knowledge, provides the highest spatial resolution mapping results

3.3 REXIS Science Data Products

There are three major science data products that are produced by the REXIS instrument, as shown schematically in Fig. 12 and further described in the caption. All three data products are derived from the single REXIS data stream. The downlinked telemetry is processed in serial to produce the successively higher spatial resolution science data products. The first-order product is produced by “Spectral Mode” which utilizes all X-ray photon counts from Bennu by summing them globally. (No spatial information is used for Spectral Mode results.) Spectral Mode satisfies the first science objective described in Sect. 1.1—categorize Bennu’s elemental abundance properties within the range of known meteorite groups. Inamdar et al. (2014) give a detailed modeling analysis for how REXIS will successfully accomplish its Spectral Mode objective.

The asteroid fluorescence measured by the REXIS instrument, from which all science products are derived, depends on the variable solar X-ray spectrum incident on the asteroid. Detailed modeling of the variable solar flux is described by Allen et al. (2013), where the model accounts for the incidence and emission angles from the surface of the asteroid within the REXIS field of view, the internal background of the detector, the scattered

solar X-rays, as well as the entering cosmic X-ray background (CXB). The method for achieving measurements of asteroid elemental abundances begins with this model fit to the solar state, synchronized in time to the arrival of X-ray photon events from the asteroid. For the solar state, REXIS uses CHIANTI single temperature and multi-temperature plasma models representative of solar X-ray emission from the corona (Dere et al. 1997; Landi et al. 2013). Global abundances for Bennu that are delivered by the Spectral Mode data product will be determined by modeling the asteroid X-ray flux for the best fit to the Fe-L, Al-K, Mg-K, Si-K, and S-K fluorescence line strengths. These resulting ratios will constrain the overall (globally averaged) composition of Bennu. Spectral mode is the most robust science product because the total accumulated integrations of all asteroid X-ray events will be co-added to produce the highest signal-to-noise measurements of each emission line present. We expect to meet the science requirements for spectral mode in <12 days of integrations with >4 detector nodes (or 3 days for all 16 nodes). REXIS has 10 working nodes at launch, with 6 of them showing good spectral response and low thresholds.

REXIS science objectives also include mapping the elemental abundance distribution across the asteroid's surface. Two additional data products satisfy spatial mapping objectives: Collimator Mode and Imaging Mode. We first describe the implementation of Imaging Mode which takes advantage of the coded aperture mask (as described in Sect. 2) to achieve imaging of regions of elemental enhancements on 50-m scales or finer, for extreme elemental composition enhancements. Every incident X-ray photon entering REXIS through a coded aperture mask hole is recorded within an 8×8 region of CCD pixels (dimension 0.192 mm) on the detector, dubbed a 'super-pixel' by Allen et al. (2013). This 0.192 mm pixel is back projected through all open 1.536 mask holes to localize its source location on the shape model map of Bennu. As X-ray event photons are accumulated throughout the REXIS data collection phase of the mission, correlation of the detected X-ray distribution (at 150 eV energy resolution) on the detector with the known mask pattern allows localized mapping of enhanced emission regions for the specific elements being investigated. (See Fig. 6 of Allen et al. 2013 for further modeling details; these demonstrate the progression of mapping resolutions we show here in our Fig. 12.) The choice of a 4 second integration time is based on the planned operation from a 700 meter altitude (Orbital Phase B), where an image "smear" of less than 1/3 REXIS pixel is expected in this interval.

In terms of the processing of the main REXIS science data stream, the event list detected X-ray photons is used to produce a reconstructed intensity map as a function of position on the sky in the REXIS field of view for each element of interest by application of an energy sampling around the individual fluorescence lines. The reconstruction of the sky image on a tangential projection is carried out by fast Fourier transform (FFT) cross-correlation with the REXIS mask pattern. Precision knowledge of the spacecraft pointing, commensurate with (or better than) the mapping resolution is necessary in order to take full advantage of the cross-correlation with the REXIS mask pattern. In conjunction with the best available asteroid shape model and precise knowledge of the spacecraft pointing direction and altitude above the surface of Bennu, the individual intensity maps are co-added as a function of position on the asteroid surface, yielding a high-resolution global elemental abundance map. This procedure is run in parallel for all elemental lines of interest, producing a single map for each element. In order to normalize the co-addition of the individual maps to solar state, the best fit model for the incident solar flux is used in order to calculate the intensity of each fluorescent X-ray emission line for each 4-s integration to derive the normalization correction. For the expected composition of Bennu, an elevated solar state equivalent to a single temperature of at least 5.5 MK with an output flux of 1.6×10^{-7} W/m² between 1.0 and 8.0 angstroms over a total exposure time of ~20 days is a first-order estimate for any

measurement. Requirements cannot be put on the sun, of course. However, if the solar state is at or above this flux over a ~ 20 -day exposure time, the 10 functional CCD detector nodes will be sufficient to meet the original Imaging Mode performance goal.

Collimator Mode imaging reconstruction is carried out in a similar manner to that of the Imaging Mode, where the key difference is that the response function of the entire REXIS instrument over the full FoV containing Bennu is used rather than individual mask pixels for the reconstruction of individual asteroid images. In other words, Collimator Mode acts like a wide-field telescope (ignoring the mask pattern) where the center of the FoV and accuracy of the mapping is dependent on the knowledge of the spacecraft pointing. The outcome for Collimator Mode is thus lower angular resolution, equivalent to a nominal 280-m^2 patch on the surface of the asteroid, but higher sensitivity is achieved through the co-adding of pixels. For Collimator Mode, the terminator orbit configuration for OSIRIS-REx during the REXIS observations is advantageous for improving spatial resolution in Collimator Mode, because the measured emission can be considered to originate from the surface area of the asteroid filling approximately one-half of the field of view. Also similar to Imaging Mode, for each detector plane image, the OSIRIS-REx spacecraft position and subsolar position as a function of time is retained to enable normalized co-addition in asteroid coordinates yielding elemental abundance maps for the entire surface of Bennu.

4 REXIS Student Experience and Achievements

REXIS is poised to achieve the first coded aperture wide-field imaging for fluorescent X-ray composition mapping of an asteroid. This path-finding accomplishment for the future of planetary exploration has been made possible by a student collaboration experiment executed in a resource-limited cost-capped environment for a Class D instrument, integrated to a Risk Class B mission. REXIS has (to date) provided hands-on experience for 60 students (44 undergraduates, 16 graduates) in classroom, laboratory, and clean-room settings. The latter includes participating in the December 18, 2015, mounting of the fully functioning instrument directly to the OSIRIS-REx spacecraft, pictured in Fig. 13. Dedicated mentorship has been the key to REXIS success, and this has been unfailingly and generously provided by the engineering staffs of Goddard Space Flight Center and Lockheed Martin as well as the multiple units within our respective universities. Through this expert mentorship the REXIS project (currently spanning six years) has been managed through numerous transitions of student team members who graduate and move on while new students take their place.

In addition to the hands-on experience, the REXIS project has been a central component of ten Master's theses and two Ph.D. dissertations. These titles are summarized in Table 2. In addition, five student journal and conference publications have been published to date (Allen et al. 2013; Carte et al. 2014; Inamdar et al. 2014; Jones et al. 2014; Stout and Masterson 2014). The steps to REXIS progressed across five academic years and a series of academic subjects. For the 2011–2012 academic year, the subjects *Space Systems Engineering* and *Space Systems Development* brought undergraduate students through the Systems Requirements Review and Systems Definition Review. REXIS then transitioned during the 2012–2013 academic year into graduate-level work in *Satellite Engineering*, where the assignments were to develop analytical integrated models subject to peer reviews. Preliminary Design Review for REXIS occurred during the January interim between fall and spring semesters, followed by ongoing engineering test unit refinements and testing. Beginning with the 2013–2014 academic year, REXIS moved largely out of the classroom setting into the hands-on laboratory work led by graduate students performing Master's level and



Fig. 13 REXIS instrument mounted onto the OSIRIS-REx spacecraft, December 18, 2015

Table 2 Master's and Ph.D. theses derived from REXIS experience (through 2016)

Master's

Sondecker, G. "Identification and Evolution of Quantities of Interest for a Stochastic Process View of Complex Space System Development," S. M. MIT, 2011

Bralower, H. "Mechanical Design, Calibration, and Environmental Protection of the REXIS DAM," S.M. MIT 2013

Schmidt, F. "Fault-Tolerant Design Implementation on Radiation Hardened by Design SRAM-Based FPGAs," S.M. MIT, 2013

Stout, K. "Design Optimization of Thermal Paths in Spacecraft Systems," S.M. MIT, 2013

Chodas, M. "Improving the Design Process of REXIS with Model-Based Systems Engineering," S.M. MIT, 2014

Carte, D. "The REgolith X-ray Imaging Spectrometer Flight Model: Structural Design, Analysis, and Testing," S.M. MIT 2015

Jones, M. "The Engineering Design of the REXIS Solar X-ray Monitor and Risk Management Considerations for Resource Constrained Payload Development," S.M. MIT 2015

Bayley, L., "Integration and Test of the REgolith X-ray Imaging Spectrometer (REXIS) and Recommendations for Low-Cost, High-Risk Spaceflight Programs," S.M. MIT, 2016

Biswas, P. "Radiation Management, Avionics Development, and Integrated Testing of a Class-D Space-Based Asteroid X-ray Spectrometer," S.M. MIT 2016

McMenamin, C. "Application of Bayesian-based uncertainty and global sensitivity analyses to aide in spacecraft thermal design," S.M. MIT 2016

Ph. D.

Smith, M. "Model-Based Requirement Definition for Instrument Systems," Ph.D. MIT, 2014

Stout, K. "Bayesian-based Simulation Model Validation for Spacecraft Thermal Systems," Ph.D. MIT, 2015

Fig. 14 In-flight performance of the REXIS instrument for the detection and resolution of the onboard ^{55}Fe calibration sources. Data are shown from thermal-vacuum chamber (TVAC) testing prior to launch and at Launch + 14 days. ^{55}Fe lines at 5.9 and 6.5 keV are detected and resolved

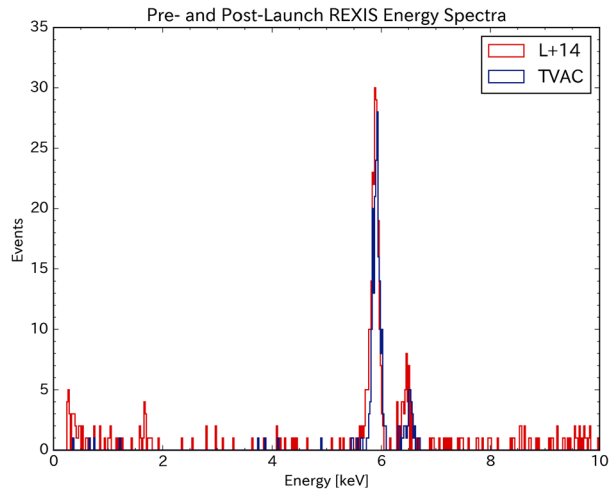

Ph.D. level research on all aspects of mechanical, thermal, electronic, and software design. REXIS served as a focal point or case study in the range of these topics given in Table 2. At all phases, undergraduate students worked alongside the graduate students and REXIS staff as part of the MIT Undergraduate Research Opportunities Program (UROP). During this initial year of hands-on laboratory experience, engineering model design and build was brought to completion. Engineering model CCID-41s were delivered, and the completed engineering model underwent its environmental testing. Critical Design Review similarly occurred near the midway point of the 2013–2014 academic year.

Assembly of the flight model and its integration and test occurred during the 2014–2015 academic year. These activities included development of the flight software, implementation of the flight electronics design, and the receipt and testing of the flight model CCID-41s. REXIS Pre-Environmental Review and flight environment testing commenced at the end of the 2015 academic year through the summer. Fall 2015 brought the pre-ship review, the unveiling of electronic performance challenges, diagnosis, and repair followed by requalification, and finally mounting on the OSIRIS-REx spacecraft before the end of the calendar year. Spring 2016 engaged the REXIS students in systems-level testing of the full spacecraft payload, delivery of OSIRIS-REx to Cape Canaveral, followed by on-pad testing. Launch of REXIS aboard OSIRIS-REx occurred in September 2016, leading to in-flight testing being designed and implemented by graduate students playing leading roles in systems engineering. Post-launch checkout shows REXIS performance matching pre-launch testing (Fig. 14). While REXIS is in flight, ongoing laboratory work in calibrating hardware performance and developing data processing pipeline software involves both undergraduate and graduate students.

Real-world experiences proving that space flight hardware development is demanding and unforgiving of error have been a true part of the REXIS experience. These experiences include, but have not been limited to: contamination of flight detectors (placing them outside of stringent mission cleanliness requirements) in a vacuum chamber failure, loss of parts due to a shipping service's highway accident, handling damage to CCD flex-print cables, and seasonally recurring record snowfalls in Boston during times of scheduled reviews and critical tests. Anomalies in vibration tests, a late discovered unpowered connection to the SXM trigger circuit, and ground loop noise posing a severe threat to the science performance (fully recognized as solvable only at the original schedule date for spacecraft installation)

brought REXIS to the brink of a Cancellation Review. These trials brought out the best in the students and staff who continuously rededicated themselves to the success of REXIS, providing the most significant lesson of all.

Acknowledgements This work was conducted under the support of the OSIRIS-REx program through research funds from Goddard Space Flight Center. REXIS would not have been possible without supporting expertise, facilities, and mentorship at MIT Kavli Institute provided by Marshall W. Bautz and at MIT Lincoln Laboratories provided by Kevin Ryu, Keith Warner, Jim Kelly, Joe Orrender, Jeff Mendenhall, Marc Bernstein, and others. Vital expertise, critiques, and advice came through our NASA partners that included James Dailey, Joe Schepis, Dave Petrick, Blair Russell, Mike Choi, Mike Pryzby, Libby Adelman, Mary Walker, Ed Powers, Steve Battel, and Mark Kahan. While this paper details the work through launch and early checkout, we gratefully acknowledge assistance in the final preparation of this manuscript by the most recently arriving REXIS team members Carolyn Thayer, Sormeh Yazdi, Daniel Hoak, and David Guevel.

References

- I. Adler, J. Gerard, J. Trombka, R. Schmadebeck, P. Lowman, H. Blodget, L. Yin, E. Eller, R. Lamothe, P. Gorenstein, P. Bjorkholm, B. Harris, H. Gursky, The Apollo 15 x-ray fluorescence experiment, in *Lunar and Planetary Science Conference Proceedings*, ed. by A.E. Metzger, J.I. Trombka, L.E. Peterson, R.C. Reedy, J.R. Arnold. Lunar and Planetary Science Conference Proceedings, vol. 3 (1972), p. 2157
- B. Allen, J. Grindlay, J. Hong, R.P. Binzel, R. Masterson, N.K. Inamdar, M. Chodas, M.W. Smith, M.W. Bautz, S.E. Kissel, J. Villaseñor, M. Oprescu, N. Induni, The REgolith X-ray Imaging Spectrometer (REXIS) for OSIRIS-REx: identifying regional elemental enrichment on asteroids, in *Society of Photo-Optical Instrumentation Engineers (SPIE) Conference Series*, vol. 8840 (2013)
- P. Biswas, Radiation management, avionics development, and integrated testing of a class-D space-based asteroid X-ray spectrometer. Masters thesis, Massachusetts Institute of Technology, Cambridge, September 2016
- H. Bralower, Mechanical design, calibration, and environmental protection of the REXIS DAM. Masters thesis, Massachusetts Institute of Technology, Cambridge, September 2013
- D.B. Carte, N.K. Inamdar, M.P. Jones, R.A. Masterson, Design and test of a deployable radiation cover for the REgolith X-ray imaging spectrometer, in *42nd Aerospace Mechanisms Symposium* (NASA Goddard Space Flight Center, Washington, 2014)
- E.F. Crawley, J. Malmqvist, S. Ostlund, D.R. Bordeur, *Rethinking Engineering Education: The CDIO Approach* (Springer, New York, 2007). <https://doi.org/10.1007/978-0-387-38290-6>
- K.P. Dere, E. Landi, H.E. Mason, B.C. Monsignor Fossi, P.R. Young, CHIANTI—an atomic database for emission lines. *Astron. Astrophys. Suppl. Ser.* **125**, 149–173 (1997)
- J.O. Goldsten et al., The x-ray/gamma-ray spectrometer on the near Earth Asteroid Rendezvous mission. *Space Sci. Rev.* **82**, 169–216 (1997)
- C.E. Grant, M.W. Bautz, S.M. Kissel, B. LaMarr, A charge transfer inefficiency correction model for the Chandra advanced CCD imaging spectrometer, in *Proceedings of the SPIE*, vol. 5501 (2004)
- M. Horanyi et al., The student dust counter on the New Horizons mission. *Space Sci. Rev.* **140**, 387–402 (2008)
- N.K. Inamdar, R.P. Binzel, J. Hong, B. Allen, J. Grindlay, R.A. Masterson, Modeling the expected performance of the REgolith X-ray Imaging Spectrometer (REXIS), in *Proceedings SPIE*, vol. 9222 (2014). <https://doi.org/10.1117/12.2062202>
- M. Jones, The engineering design of the REXIS solar X-ray monitor and risk management considerations for resource constrained payload development. Masters thesis, Massachusetts Institute of Technology, Cambridge, May 2015
- M. Jones, M. Chodas, M.J. Smith, R.A. Masterson, Engineering design of the REgolith X-ray Imaging Spectrometer (REXIS) instrument: an OSIRIS-REx student collaboration, in *Space Telescopes and Instrumentation 2014: Ultraviolet to Gamma Ray*, ed. by T. Takahashi, J.-W.A. den Herder, M. Bautz. *Proc. of SPIE*, vol. 9144 (2014), 914453. <https://doi.org/10.1117/12.2056903>
- B. LaMarr, C. Grant, S. Kissel, G. Pribozhin, M. Bautz, T.G. Tsuru, H. Tsunemi, T. Dotani, K. Hayashida, H. Matsumoto, Front- and back-illuminated X-ray CCD performance in low- and high-Earth orbit: performance trends of Suzaku XIS and Chandra ACIS detectors, in *Proceedings of the SPIE*, vol. 70112C-1 (2008)
- E. Landi, P.R. Young, K.P. Dere, G. Del Zanna, H.E. Mason, CHIANTI—an atomic database for emission lines. XIII. Soft X-ray improvements and other changes. *Astrophys. J.* **763**, 86 (2013)

- D.S. Lauretta, A.E. Bartels, M.A. Barucci, E.B. Bierhaus, R.P. Binzel, W.F. Bottke, H. Campins, S.R. Chesley, B.C. Clark, B.E. Clark, E.A. Cloutis, H.C. Connolly, M.K. Crombie, M. Delbó, J.P. Dworkin, J.P. Emery, D.P. Glavin, V.E. Hamilton, C.W. Hergenrother, C.L. Johnson, L.P. Keller, P. Michel, M.C. Nolan, S.A. Sandford, D.J. Scheeres, A.A. Simon, B.M. Sutter, D. Vokrouhlický, K.J. Walsh, The OSIRIS-REx target asteroid 101955 Bennu: constraints on its physical, geological, and dynamical nature from astronomical observations. *Meteorit. Planet. Sci.* **50**, 834–849 (2015)
- L.R. Nittler, R.D. Starr, L. Lim, T.J. McCoy, T.H. Burbine, R.C. Reedy, J.I. Trombka, P. Gorenstein, S.W. Squyres, W.V. Boynton, T.P. McClanahan, J.S. Bhangoo, P.E. Clark, M.E. Murphy, R. Killen, X-ray fluorescence measurements of the surface elemental composition of asteroid 433 Eros. *Meteorit. Planet. Sci.* **36**, 1673–1695 (2001)
- L.R. Nittler, T.J. McCoy, P.E. Clark, M.E. Murphy, J.I. Trombka, E. Jarosewich, Bulk element compositions of meteorites: a guide for interpreting remote-sensing geochemical measurements of planets and asteroids. *Antarct. Meteor. Res.* **17**, 231–251 (2004)
- P.P. Plucinsky, A.P. Beardmore, A. Foster, F. Haberl, E.D. Miller, A.M.T. Pollock, S. Sembay, SNR 1E 0102.2-7219 as an X-ray calibration standard in the 0.5–1.0 keV bandpass and its application to the CCD instruments aboard Chandra, Suzaku, Swift and XMM-Newton. *Astron. Astrophys.* **597**, A35 (2017)
- G. Prigozhin, K. Gendreau, J. Doty, R. Foster, R. Remillard, A. Malonis, B. LaMarr, M. Vezie, M. Egan, J. Villaseñor, Z. Arzoumanian, W. Baumgartner, F. Scholze, C. Laubis, M. Krumrey, A. Huber, NICER instrument detector subsystem: description and performance, in *SPIE Proceedings*, vol. 9905 (2016)
- G.R. Ricker et al., Transiting exoplanet survey satellite. *J. Astron. Telesc. Instrum. Syst.* **1**(1), 014003 (2014)
- K.K. Ryu, B.E. Burke, H.R. Clark, R.D. Lambert, P. O'Brien, V. Suntharalingam, C.M. Ward, K. Warner, M.W. Bautz, R.P. Binzel, S.E. Kassel, R.A. Masterson, Development of CCDs for REXIS on OSIRIS-REx, in *Space Telescopes and Instrumentation 2014: Ultraviolet to Gamma Ray*, ed. by T. Takahashi, J.-W.A. den Herder, M. Bautz. *Proc. of SPIE*, vol. 9144 (2014), 914440
- F. Schmidt, Fault tolerant design implementation on radiation hardened by design SRAM-based FPGAs. Masters thesis, Massachusetts Institute of Technology, Cambridge, June 2013
- G.K. Skinner, Sensitivity of coded aperture telescopes. *Appl. Opt.* **47**(15), 2739–2749 (2008)
- K.D. Stout, R.A. Masterson, Thermal design and performance of the REgolith X-ray Imaging Spectrometer (REXIS) instrument, in *Modeling, Systems Engineering, and Project Management for Astronomy VI*, ed. by G.Z. Angeli, P. Dierickx. *Proc. of SPIE*, vol. 9150 (2014), 91501J. <https://doi.org/10.1117/12.2054995>