



A comprehensive survey on hybrid wireless networks: practical considerations, challenges, applications and research directions

Syed Agha Hassnain Mohsan¹ · Hussain Amjad²

Received: 13 April 2021 / Accepted: 22 July 2021 / Published online: 14 August 2021
© The Author(s), under exclusive licence to Springer Science+Business Media, LLC, part of Springer Nature 2021

Abstract

Wireless communication refers to data transfer in an unguided propagation medium through wireless carriers such as visible light (VL) and radio frequency (RF). The rapidly growing demand for high data rates overloads conventional RF wireless communication. Therefore, technologies such as cognitive radios and millimeter waves (mmWaves) have been utilized to overcome capacity limitation and spectrum scarcity of RF systems. In parallel, optical wireless communication (OWC) is a promising alternative solution to its radio frequency (RF) compeer. OWC has been revolutionized to support fifth generation (5G) wireless communication and Internet-of-Things (IoT) terminals. In addition, OWC has no health hazard, low power consumption, unlicensed spectrum and shows immunity to interferences from electromagnetic sources. As RF and OWC are compatible, so a joint application scenario is referred as an excellent solution to support 5G and beyond systems. Hybrid optical/optical and RF/optical system is a promising approach to remove the limitations of each system as well as to enable supporting features of each technology. An optical/optical hybrid system is based on two or more OWC technologies while RF/optical hybrid system contains both RF and OWC technologies. The hybrid systems can enhance system performance in terms of energy efficiency, reliability and throughput of each system. Thus, hybrid RF/optical systems are envisioned as a key enabler to enhance user mobility and data rate on the one hand and to optimize power consumption, network load, interference and network capacity on the other hand. This survey seeks to provide the state-of-the-art and future research directions regarding optical wireless hybrid networks. This paper represents a technological overview of existing optical wireless hybrid networks. We have discussed optical-based free-space optics (FSO), optical camera communication (OCC), light fidelity (LiFi) which extends the concept of visible light communication (VLC) to attain bi-directional and fully networked wireless communication, as well as RF-based Bluetooth, wireless fidelity (WiFi), small cell, macrocell, mmWave and microwave. In addition, we have also considered underwater acoustic communication for acoustic/optical and acoustic/RF hybrid networks. An extensive range of applications such as indoor, vehicular communication, eHealth, backhaul connectivity solution and underwater communication is considered. We have addressed potential challenges and open research issues for design and successful deployment of hybrid wireless networks.

Keywords 5G · Free-space optics (FSO) · Light fidelity (LiFi) · Visible light communication (VLC) · RF/optical hybrid · Radio frequency and optical wireless communication (OWC)

1 Introduction

Recently, there has been an upsurge in multimedia applications, involving a huge number of mobile data traffic, which requires high data rates. The current fifth generation (5G) offers several new services including high quality of experience (QoE), ultra-low energy consumption, ultra-high security, ultra-low latency, massive connectivity and ultra-high capacity (Shafi 2017; Zhang et al. 2016; Ijaz 2016). The extremely high data requirement involves a major challenge for fifth generation (5G) and beyond fifth generation (B5G). This exponential growth of mobile data requires reliable and efficient technical solutions to ensure high quality of service (QoS) for network users.

It is worth mentioning that RF-based communication involves restriction in terms of limited spectrum usage in wireless networks (Obeed et al. 2018; Ghassemlooy et al. 2015). Therefore, many researchers prefer license-free optical spectrum (1–10 nm) as a promising alternative to RF. The communication technique which uses this free optical spectrum is called optical wireless communication (OWC) (Koonen 2017; Boucouvalas et al. 2015; Chowdhury 2019; Wu 2020; Ding et al. 2020). OWC has emerged as a promising solution after the rapid progress of LEDs (Chun 2016; Karunatilaka et al. 2015). OWC technology makes use of wide optical spectrum as well as provides high performance communication features such as high energy efficiency, high security and freedom from electromagnetic interference (Arnon et al. 2012; Yasir et al. 2014; James Singh et al. 2020; Watson et al. 2016; Ji et al. 2018). Tesonev et al. (2015) demonstrated visible light wireless access network with a data rate of 100 Gbps. In order to realize communication, some OWC technologies such as light fidelity (LiFi) and visible light communication (VLC) utilize existing optical infrastructures (Yang et al. 2017; Cahyadi et al. 2020; Bao et al. 2015). The installation cost of OWC technologies can be reduced as they do not require high infrastructure (Karunatilaka et al. 2015). OWC also enables high security, as light cannot pass through walls so it provides privacy and security to users inside room. These OWC technologies use visible light (VL), infrared radiation (IR) and ultraviolet (UV) light as propagation medium. Several OWC systems are being designed on the basis of these optical bands for different application scenarios (Sohn et al. 2020; Arya and Chung 2020; Miladić-Tešić et al. 2020; Mei et al. 2020). The most common OWC technologies are free-space optical (FSO) communication, LiFi, optical camera communication (OCC), visible light communication (VLC) and Light Detection and Ranging (LiDAR) (Chowdhury et al. 2018). In these aforementioned OWC technologies, propagation media, architecture, protocol and application scenarios vary from each other. Table 1 summarizes different characteristics of these OWC technologies and a comparison with radio technologies.

Every optical wireless technology (LiDAR, FSO, OCC, LiFi and VLC) has its unique operation and architecture. These technologies vary from each other in terms of communication media, transceiver system, modulation techniques and application scenarios. For instance if we compare VLC and LiFi, VLC is considered point-to-point data communication techniques, while, LiFi is conceived as a full wireless networking system. LiFi extends the concept of visible light communication (VLC) to achieve fully networked, bi-directional multiuser communication (point-to-multipoint and multipoint-to-point), high speed

Table 1 Comparison of OWC and radio systems

Characteristic	OWC system	Radio system
Power consumption	Low	High
Cost	Low	High
Bandwidth regulation	No	Yes
Multipath fading	Yes	Yes
Transmitter power	Interference and eye-safety	Interference
Bandwidth availability	Very high	Low
Beam directivity	High	Low
Walls penetration	No	Yes
EM interference	No	Yes
Security	High	Low
Noise sources	Ambient light and sunlight	Other systems and users
EM compatibility	Yes	Conditional
Eyes safety concerns	Necessary	N/A
Sensitivity of receiver	Low	High
SNP	Related to optical power	Related to amplitude of RF signal
Direction	Incoherent	Coherent or incoherent
Noise source	Ambient noise, sunlight	Electrical noise, interference from nearby devices
Multipath distortion	Only in diffuse indoor	Yes
Path loss	High	High
Bandwidth	Unlicensed	Licensed
Antenna complexity	Moderate	High
Major challenge	Environment limitation	Power limitation

and secure wireless communications (Haas et al. 2015). LiFi utilizes high frequency flickering of LED to transmit data and photodetector (PD) is used on the receiver side. Hence, LiFi supports full user mobility forming a new layer within existing heterogeneous wireless networks. It is similar to IEEE 802.11 standards and support multiple access schemes and handover mechanism. However, it faces interference from neighboring light sources. As a result, higher bit-error rate (BER) and average signal-to-interference-plus-noise ratio (SINR) are observed in LiFi.

In hardware architecture, these OWC technologies use LDs or LEDs as optical source while cameras or PDs are used as receiver. Communication media is based on UV, VL or IR. Table 2 summarizes the uplink and downlink information in communication link and transceiver of various optical wireless technologies.

In spite of OWC advantages, there are some drawbacks such as limited transmitted power, performance degradation due to outdoor atmosphere, ambient light interference, blockage in light path and line-of-sight (LOS) dependence. Thus, it is a major challenge to overcome these limitations. On the other hand, RF band (3 kHz–300 GHz) is monetarized by international authorities (Chowdhury et al. 2018). RF-based communication is severely affected by interference. However, RF-based communication provides high performance in non-line-of-sight (NLOS) scenario and enables high mobility.

In order to provide high QoS, the hybrid network of both RF and optical technologies can play a vital role by introducing a diverse spectrum to support new applications. The

Table 2 Basic characteristics of different optical wireless technologies

Technology	Communication link		Transmitter		Receiver	
	Uplink	Downlink	Uplink	Downlink	Uplink	Downlink
OWC	UV/VL/IR	UV/VL/IR	LD/LED	LD/LED	Camera/PD	Camera/PD
LiDAR	VL/IR	VL/IR	No	LD	Camera/PD	No
FSO	UV/VL/IR	UV/VL/IR	LD	LD	PD	PD
OCC	VL/IR	VL/IR	LED	LED	Camera/PD	Camera
LiFi	UV/VL/IR	VL	LED	LD/LED	PD	PD
VLC	VL	VL	LD/LED	LD/LED	PD	Camera/PD

convergence of heterogeneous networks (HetNets) can support new applications. HetNets are formed by simultaneous operations of two or more technologies e.g. macrocell, microcell, femtocell, power line communication (PLC), Bluetooth Low Energy (BLE) and WiFi or LiFi, FSO, VLC and OCC etc. In HetNets, various technologies integrate to overcome QoS, interference reduction, security enhancement, remote wireless connectivity, high energy efficiency, seamless mobility, link-reliability, smart handover, optimum resource allocation and load balancing (Li et al. 2016a; Wu et al. 2020a, 2020b; Alsulami et al. 2020).

Several research studies have presented hybrid RF/optical wireless systems (Pan et al. 2017; Linag et al. 2017; Sarigiannidis et al. 2017; Wang et al. 2017a; Mufutau et al. 2020; Delgado-Rajo et al. 2020; Papanikolaou et al. 2020). In hybrid RF/optical systems, users can get both wide coverage area of RF systems and stable rates of optical systems. Such hybrid systems can be successfully deployed without causing interference for each other and can feasibly operate in rooms and offices. The hybrid systems are based on different configurations such as acoustic/optical, acoustic/RF, optical/optical, and RF/optical (Jin et al. 2014; Aldalbahi et al. 2017; Basnayaka and Haas 2017; Feng et al. 2016; Baig et al. 2018; Wang and Haas 2015; Zhou et al. 2017; Nguyen et al. 2019; Tsai et al. 2019; Ai et al. 2020; Wu et al. 2021a; Zeng et al. 2020; Liu et al. 2020). In terrestrial perspective, we can use both optical/optical and RF/optical hybrid systems. In underwater environment, acoustic/optical or acoustic/RF hybrid systems can be used. An important key feature of these hybrid networks is to build multi-tier networks. Figure 1 presents an overview of multi-tier networks. It shows that 5G macrocellular base station (MBS) enables a wide coverage area while Femtocell Access Point (FAP) and WiFi develops a small tier. A three-tier network is designed after LiFi or VLC. We can use an OCC system inside a shopping mall to build two-tier network. Furthermore, users can access LiFi, femtocell to create a three-tier network in a bus.

To the best of our knowledge, there are very few review articles which provide comprehensive discussion about hybrid optical wireless systems. This survey presents comprehensive details about optical wireless, acoustic/RF and acoustic/optical hybrid systems. For better understanding, we have presented related reviews and surveys on OWC, RF and hybrid networks in Table 3. Our survey highlights potential challenges and open research issues in various hybrid networks. In this survey, we discuss several OWC technologies e.g. FSO, LiFi, OCC and VLC as well as RF technologies including mmWave, Bluetooth, radio frequency identification (RFID), WiFi, macrocell and femtocell. We have briefly discussed acoustic/optical and acoustic/RF hybrid networks. Figure 2 presents an overview of different hybrid systems. These hybrid systems can be

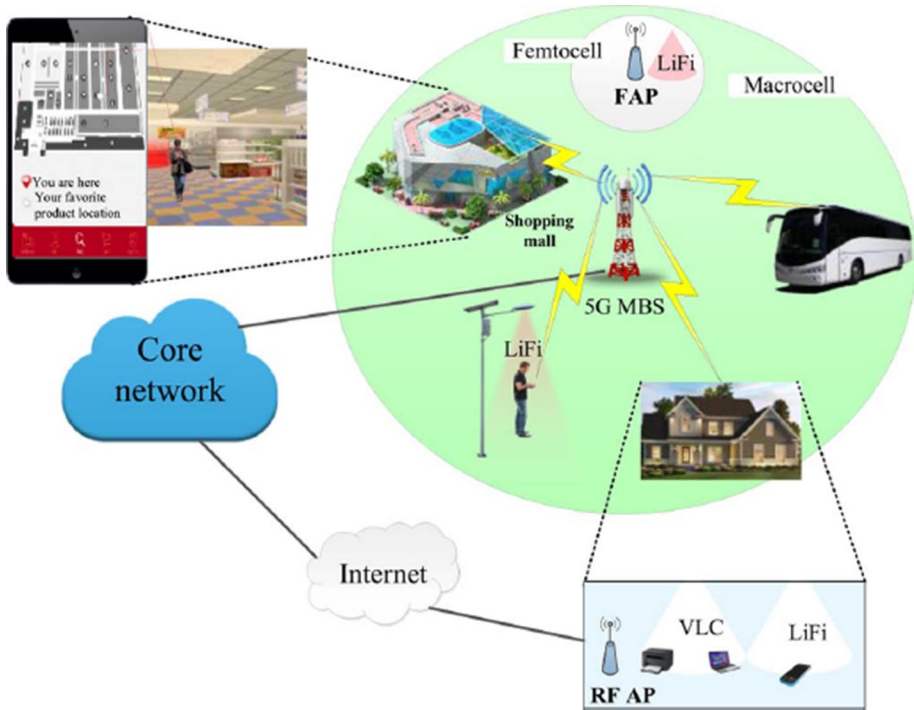

Fig. 1 Multi-tier networks (Chowdhury et al. 2020)

configures as FSO/OCC, LiFi/OCC, VLC/OCC, BLE/OCC, PLC/VLC, RF/FSO, WiFi/LiFi, femtocell/VLC, femtocell/LiFi, WiFi/VLC, RF/OCC, RF/LiFi and RF/VLC.

The rest of the article is arranged as follows; Sect. 2 represents the system overview and discussion about different OWC and RF technologies. RF/optical wireless hybrid networks and some implemented projects have been explained in Sect. 3. Section 4 discusses acoustic/RF and acoustic/optical wireless hybrid networks. Optical/optical wireless hybrid networks are discussed in Sect. 5. Different challenges and open research issues are outlined in Sect. 6. A brief conclusion of our work is provided in the final section.

2 System overview

Hybrid systems integrate two or more wireless technologies to provide better performance and remove limitations of each technology. The optical/optical wireless hybrid systems provide the integration of two or more OWC systems while RF/optical wireless hybrid systems provide the convergence of RF and OWC systems. The basic idea of hybrid wireless systems is similar to fixed-mobile convergence (FMC) in which wired and wireless technologies integrate to form single solution (Samdanis et al. 2017). FMC enables seamless connectivity and delivers services between fixed and wireless networks.

Table 3 Related studies on OWC technologies

References	Research contribution	Optical wireless system
Ghassemlooy et al. (2015)	This article focuses on OWC systems including optical scattering, FSO, VLC, UOWC etc	OWC
Karunatilaka et al. (2015)	It is a comprehensive survey on LED based VLC. It discusses challenges, limitations and future directions of VLC systems	VLC
Saha et al. (2015)	It highlights OCC overview, challenges, opportunities, modulation schemes and future directions	OCC
Kaushal and Kaddoum (2016a)	It provides an extensive overview of recent advances in UOWC, coding techniques, modulation schemes, channel characterization and hybrid acoustic-optic approach	UOWC
Khan (2017)	This article surveys VLC system architecture, standardization, modulation schemes, potential applications and research challenges	VLC
Son and Mao (2017)	It presents a survey of FSO networks, three subnetworks, state-of-the-art research and major challenges	FSO
Zeng et al. (2017)	This paper focuses on practical implementation of UOWC and state-of-the-art in the aspects of coding techniques, modulation schemes and channel characterization	UOWC
Căilean and Dimian (2017)	It was the first extensive survey to address VLC issues in vehicular communication applications. It investigates major challenges for VLC usage in vehicular communication and future research directions for the automotive VLC applications	VLC
Koonen (2017)	This paper discusses indoor optical communication system trends, applications and two major directions. It also presents bidirectional all-optical wireless and hybrid optical/radio networks	OWC
Chowdhury et al. (2018)	It presents a comprehensive survey on architecture and applications of optical wireless technologies. In this article, authors have discussed hybrid network architectures in open issues and future research directions	OWC
Ji et al. (2018)	It presents state-of-the-art and enabling technologies for high speed VLC systems	VLC
Al-Kinani et al. (2018)	It provides a brief history of OWC, channel modeling, OWC link performance and future research directions for OWC channel measurements	OWC
Saeed et al. (2019a)	This paper presents a comprehensive survey of OCC, use cases, challenges and future research directions	OCC
Chowdhury et al. (2019a)	OWC prospects, challenges and future directions in 5G/6G and IoT solutions	OWC
You et al. (2019)	This study proposes a location-based equalization (LBE) technique using orthogonal frequency division multiplexing (OFDM) for VLC. The location information of VLC receiver is used for channel estimation with LBE. This channel estimation can be further utilized for real-time mitigation of multi-path effects. Thus, channel distortion can be predicted which makes VLC as a smart location-based value-added service	VLC
Saeed et al. (2019b)	It provides a comprehensive survey on UOWC, networking and localization techniques	UOWC

Table 3 (continued)

References	Research contribution	Optical wireless system
Rehman et al. (2019)	It discusses existing literature on VLC, system perspectives and potential challenges to practically implement and integrate VLC	VLC
Haas (2020)	It presents indoor networking concepts and challenges in LiFi. It discusses hybrid LiFi/WiFi and its real world deployment	LiFi
Liu and Xu (2020)	This article provides an overview of OCC, some practical constraints, solutions and future research directions	OCC
Schirripa Spagnolo et al. (2020)	It presents an extensive study on UOWC, recent studies, current technologies and guidance for future researchers in this domain	UOWC
Lorrière (2020)	This paper proposes a comparison of PV module and APD for LiFi systems. It presents a PV module which can support LiFi transmission under additional solar illumination	LiFi
Nan and Hui (2020)	This article discusses challenges, progress and prospects of high speed VLC systems	VLC
Ndjongue et al. (2020)	This article focuses on feasibility and challenges in VLC-based networks	VLC
Chowdhury et al. (2020)	This study surveys the literature on optical wireless hybrid networks. Authors have briefly highlighted opportunities, challenges and research directions regarding optical wireless hybrid networks	Hybrid optical wireless networks
Wu et al. (2021a)	This article surveys hybrid LiFi and WiFi networks (HLWNets) including network architectures, modulation schemes, key performance metrics and illumination requirements. Authors have elaborated the unique challenges facing HLWNets including load balancing, handover, interference management and user behavior modeling	Hybrid LiFi and WiFi
This survey	In this article, we have discussed hybrid RF/optical, optical/optical, RF/acoustic and optical/acoustic wireless systems in details. We have briefly explained some implemented projects, several challenges and open research issues in hybrid optical wireless networks	Hybrid OWC/OWC, RF/OWC, RF/acoustic, OWC/acoustic

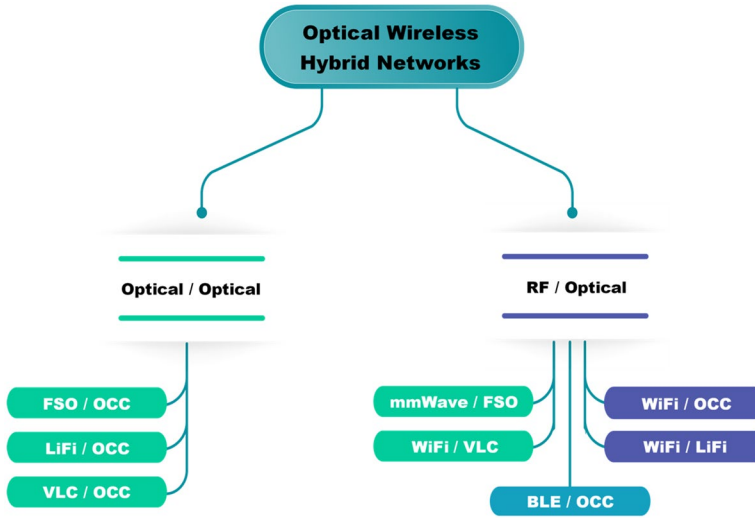

Fig. 2 Optical wireless hybrid systems (Chowdhury et al. 2020)

2.1 Overview of optical wireless technologies

In this survey, we have considered OWC and RF technologies, as well as underwater acoustic communication for hybrid systems. These technologies use different frequencies from the electromagnetic (EM) spectrum shown in Fig. 3. The different regions of EM spectrum have different names according to transmission, emission and absorption of waves. A wide

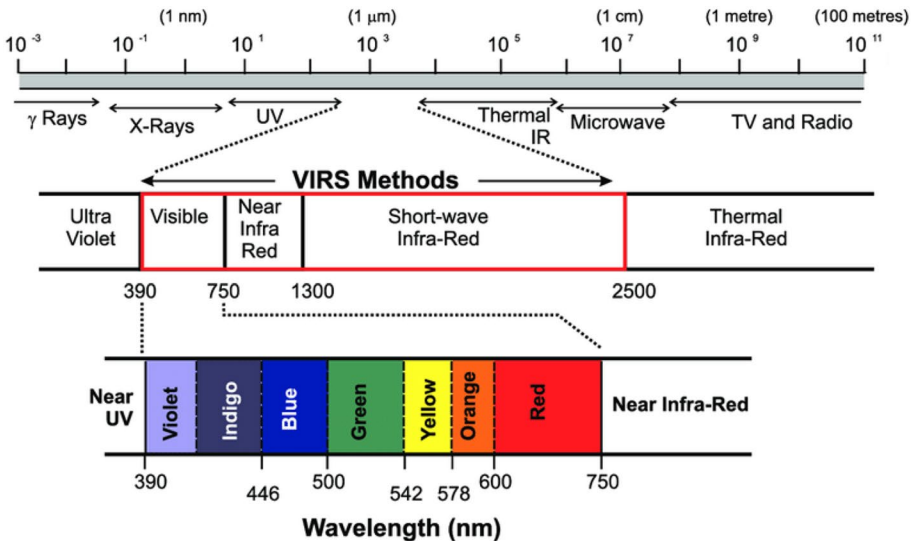

Fig. 3 Electromagnetic spectrum (Kerr et al. 2011)

region of EM spectrum supports OWC systems. We have provided a brief overview of OWC technologies below.

2.1.1 Visible Light Communication (VLC) (Yasir et al. 2014; James Singh et al. 2020; Watson, et al. 2016; Ji et al. 2018; Tsonev et al. 2015; Yang et al. 2017; Matheus et al. 2019; Zhuang 2018; Lopez-Fraguas 2019)

VLC is a new paradigm, which can revolutionize future wireless communications. VLC has become a promising candidate because of its low power consumption, high bandwidth and non-licensed spectrum. VLC has many compelling applications such as indoor wireless communication (Karunatilaka et al. 2015), smart cities (Yaqoob et al. 2017), vehicular communication (Yoo et al. 2016), underwater communication and indoor hospital and hazard-free data access (Khan 2017; Ding 2015) and smart tourism (Uema et al. 2015). VLC uses visible spectrum of 380–750 nm as shown in Fig. 4. Optoelectronic devices such as LEDs are used to transmit data in this visible light spectrum. LED source can be used for both illumination and communication purpose. High power LEDs have been introduced in VLC to enable higher data rates. VLC can also operate in those areas which are sensitive to EM waves such as hospitals and aircrafts. We have summarized milestones in VLC development in Table 4.

2.1.2 Light Fidelity (LiFi) (Bao et al. 2015; Haas 2018; Islim and Haas 2019)

High frequency wireless communication technologies have gained attention in order to overcome the looming spectrum shortage of radio frequency. LiFi is one of these technologies exploiting wide optical spectrum of 300 THz. LiFi is a bidirectional high-speed VLC system as transmitter and receiver are placed at both ends. LiFi access points (APs) can be employed in LEDs to realize dual purpose of both illumination and high-speed wireless connectivity. It is similar to WiFi which uses RF for communication. However, it uses LDs or LEDs and PDs as transmitters and receivers respectively. WiFi faces interference with nearby RF signals. Therefore, LiFi can be a good alternative at such places which are sensitive to EM radiation. LiFi has several advantages over RF counterpart such as (i) secure wireless communication, (ii) operation in RF restricted places such as underwater

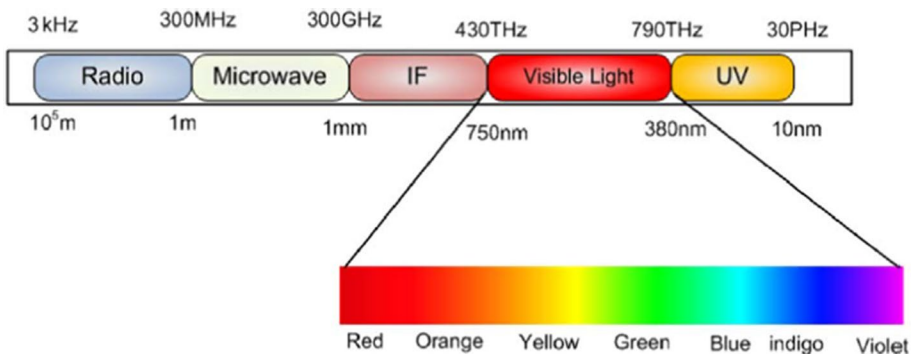

Fig. 4 Visible light spectrum (Rehman et al. 2019)

Table 4 Milestones achieved in VLC systems

References	Milestone
Pathak et al. (2015)	It provides existing literature, challenges and technology overview of VLC and sensing
Liang et al. (2016)	Demonstration of RGB VLC by using MIMO and mobile phone camera
Wang et al. (2016)	Demonstration of underwater VLC by using single photon avalanche diode for long distance communication
Khan (2017)	It presents VLC architecture, research challenges and potential applications
Zafar et al. (2017)	Demonstration of LD based VLC for gigabit communication
Chen and You (2017)	It proposes a cooperative system for VLC and visible light positioning (VLP). Two different implementation schemes were investigated where VLC can support VLP, and VLP also benefits VLC. It provides a good approach to integrate VLC and VLP in a single system
Sebastián et al. (2018)	It investigates the role of power electronics in VLC systems
Rehman et al. (2019)	It presents overview and challenges of VLC system
Matheus et al. (2019)	This article presents concepts, challenges and applications of VLC
Blinowski (2019)	This study outlines security issues in VLC systems
Zhang et al. (2019)	This study presents hardware design and recent advances in VLC
Arfaoui (2020)	It highlights physical layer security issues in VLC systems
Elamassie and Uysal (2020)	Performance analysis and channel modeling of UVLC links
James Singh et al. (2020)	Demonstration of high speed VLC by using micro-LED
Yu et al. (2020)	In this paper, authors review conceptual designs to realize cooperative VLC and visible light positioning (VLP) functionalities. They have proposed a location-based equalization (LBE) technique for indoor VLC to compensate for multi-path channel distortion. While VLP is proposed by considering channel state information (CSI). They have also discussed the integration of VLC and VLP

Table 5 Related studies on LiFi

References	Research contribution
Tsonev et al. (2014)	It discusses LiFi for optical networking
Bao et al. (2015)	Comprehensive survey on LiFi
Alao et al. (2016)	It provides brief history of LiFi, implementation, advantages and applications
Chakraborty et al. (2017)	It highlights latest advances in LiFi technology
Haas (2018)	It highlights LiFi as a shifting paradigm in 5th generation mobile networks
Albraheem et al. (2018)	LiFi based hierarchical IoT architecture
Islim and Haas (2019)	It presents modulation schemes for LiFi
Haas (2020)	It presents indoor networking concepts and challenges in LiFi
Lorrière (2020)	It discusses photovoltaic solar cells for outdoor LiFi communications
Zhang et al. (2020a)	This study presents physical layer security in LiFi systems
Anbalagan et al. (2021)	Vehicle to vehicle data transfer and communication through LiFi technology
Spahiu et al. (2020)	LiFi based car-2-car communication

and hospitals; and (iii) license-free spectrum. However, LiFi is severely affected by ambient light sources and sunlight. Also, it is relatively short range and susceptible to connection drop due to obstacles. LiFi based IoT projects have been developed (Albraheem et al. 2018). Researchers have obtained 10 Gbps data rate by using LiFi technology (Deicke and Shwartz 2012). Table 5 presents some studies and their contribution in LiFi technology.

2.1.3 Optical Camera Communication (OCC) (Saha et al. 2015; Luo 2015; Ghassemlooy et al. 2016; Cahyadi et al. 2016; Lin et al. 2017; Teli et al. 2017; Hossan et al. 2018; Chen 2019; Chavez-Burbano 2019; Younus 2020; Duque et al. 2020)

Optical camera communication (OCC) is a new emerging VLC technique. Optical camera communication (OCC) occupies within framework of IEEE 802.15.7 m standardization. It uses LED as transmitter and camera is used to capture optical signals. The image sensor of camera is used to capture and distinguish data received from various light sources. The rapidly growing camera-mounted smart devices enable OCC to be used in promising applications such as vehicle-to- infrastructure (V2I) or vehicle-to-vehicle (V2V) communication, digital signage, localized advertising and indoor/outdoor positioning. OCC has added high stability and significant user flexibility. Noise from ambient light sources or sunlight can be discarded by separating pixels. OCC system can enable interference-free communication due to limited angel-of-view (AoV). Although stable performance can be achieved but data rate is comparatively low in outdoor conditions. Hence, OCC systems can support low data rate applications. OCC based organic and inorganic light sources are being considered for indoor localization, indoor visible light positioning (Lin et al. 2017) and short-range outdoor applications (Cahyadi et al. 2020). However, OCC has some limitations such as low data rate and low QoS due to meager sampling rates of existing commercial cameras. Table 6 presents some studies and their contribution in OCC technology.

Table 6 Related studies on OCC

References	Research contribution
Luo (2015)	Experimental demonstration of optical camera communication by using RGB LEDs
Saha et al. (2015)	A comprehensive survey on opportunities and challenges of optical camera communications
Ghassemlooy et al. (2016)	An extensive study on OCC including transmitter and receiver design, modulation scheme, MIMO technique and applications
Lin et al. (2017)	OCC for indoor visible light positioning system
Hossan et al. (2018)	Optical camera communication based indoor visible light positioning system
Chavez-Burbano (2019)	Organic light-emitting diode (OLED) based OCC system for IoT applications
Liu and Xu (2020)	This articles provides practical constraints and solutions for OCC
Cahyadi et al. (2020)	An extensive review on principles, modulations and potential challenges in OCC

2.1.4 Free-space optical (FSO) communication (Khalighi and Uysal 2014; Chaudhary and Amphawan 2014; Kaushal and Kaddoum 2016b; Lei et al. 2017; Mansour et al. 2017; Anbarasi et al. 2017; Hamza et al. 2018; Kaymak et al. 2018; Delga and Leviandier 2019; Poulton 2019; Lorences-Riesgo 2020)

Inherit high carrier frequencies of 20 THz to 375 THz enable higher data rate FSO communications. Wiretapping safety, reducing EM pollution, easy installation and license free communication are other benefits of this optical wireless communication technology. FSO enables disaster recovery, internet access to remote areas and first or last mile access. Some possible implementations of FSO are fast interplanetary internet link, working-sharing capability, real-time medical imaging, video teleconferencing, data library access and web browsing. Recent FSO systems are being investigated for High Altitude Platforms (HAP), Unmanned Aerial Vehicle (UAV), inter satellite and ground-to-ground terminals.

FSO systems use LD as transmitter and PD as receiver. Light produced from LD source is coherent, monochromatic and cover long distances. Due to these features, laser light enable high data rate point-to-point communication and low interference. FSO communication has several unique features such as low mass requirement, low power consumption, fast deployment, licensed-free spectrum and large bandwidth. However, environment conditions e.g. turbulence, scattering and absorption adversely affect the performance of FSO systems (Kaushal and Kaddoum 2016b). Turbulence-induced fading causes degradation in FSO performance due to large variation in atmospheric refractive index. Fog also severely effects optical signals leading to unavailability of free space optical (FSO) communication. Widespread deployment of FSO has hampered network availability and reliability. In addition, precise pointing is also a major issue in mobility scenario. One possible approach to improve link's availability and reliability is to converge with an mmWave radio frequency link to design a hybrid FSO/RF link. Another possible solution is switch-over FSO/RF system by using hardware switching between FSO and mmWave RF links to utilize complementary natures. Table 7 presents some studies and their contribution in FSO communication.

Table 7 Related studies on FSO and research contributions

References	Research contribution
Khalighi and Uysal (2014)	It was the first study to present transmitter/receiver structure and channel models for FSO
Kaushal and Kaddoum (2016b)	It presents FSO communication challenges and mitigation techniques
Anbarasi et al. (2017)	A comprehensive survey on channel modeling in FSO communication
Kaymak et al. (2018)	This study surveys pointing, acquisition and tracking (PAT) mechanism in FSO communication
Delga and Leviandier (2019)	It presents demonstration of FSO communications by using quantum cascade lasers
Poulton (2019)	It presents long distance FSO and LiDAR communication by using optical phased arrays
Lorences-Riesgo (2020)	Practical demonstration of 208 Gbps and 184 Gbps for 32 and 16 QAM signals for FSO link

2.2 Overview of RF technologies

Here, a brief discussion of some RF technologies is provided below:

2.2.1 RFID

Communication is the main feature of near field sensing technology like radio-frequency identification (RFID) (Paul et al. 2016). It can be used for data transfer, localization, radar detection, remote sensing and virtual communications capacity. It is a key enabler of IoT and extensively used in tag-intensive conditions. RFID tags are small wireless devices which can be used for detection purpose (Juels 2006).

2.2.2 RF femtocells (Andrews et al. 2012)

Femtocells are low-powered base-stations which operate in licensed spectrum. Femto-cell network technology is widely used to connect users with internet at home or office and offers both high QoS and high network capacity gains (Kim et al. 2009). Femtocells deployed in any network can offer better user experience and enhanced indoor coverage. The femtocell base station is known as Femtocell Access Point (FAP). It reduces the design, maintenance and functional cost of the operator. However, a major issue in femto-cell deployment is interference management.

2.2.3 Macrocellular network

Macrocellular network is usually deployed in outdoor environment to provide user mobility and high coverage area. Generally macrocellular network cannot provide high coverage to all users due to interference and variation in slow fading (Yang and Marzetta 2014). Thus, it cannot serve a large number of users in any network. Macrocellular base station does not provide high data rate and its spectrum must be operated carefully.

2.2.4 Microwave-link network (Li et al. 2016b; Waterhouse and Novack 2015)

Microwave link communication provides high data rate at a long distance up to 100 km. Microwave band covers 3–30 GHz range. It is a promising alternative to optical fiber communication (OFC) due to capability of large scale data transmission. Li et al. (2016b) demonstrated 12.5 Gbps link. It uses radio waves of microwave frequency range to transmit information between two points. However, its performance is degraded by atmospheric conditions such as rain and solar storm etc. In order to maintain the robustness of data transmission, it is essential to detect the microwave link failure.

2.2.5 Dedicated short range communications (DSRC)

DSRC is wireless communication standard which is used in short and medium range communications. DSRC is mostly used for vehicle-to-vehicle (V2V), vehicle-to-infrastructure (V2I) and infrastructure-to-vehicle (I2V) communications. DSRC system uses microwaves in the range of 5.805–5.815 GHz and 5.795–5.805 GHz. It was introduced in 1999 and later it was improved as the American Society for Testing and Materials (ASTM)-DSRC in 2003.

2.2.6 mmWave

Mostly used commercial radio communications such as WiFi use a narrow band RF spectrum of 300 MHz–3 GHz. However, RF spectrum above 3 GHz has not been explored for commercial applications. Recently, researchers have shown interest to explore and utilize this range. Such as, high data rate connections in personal area networks utilize 3.1–10.6 GHz band. 28–30 GHz has been used by local multipoint distribution services. Millimeter wave covers 30–300 GHz range. In this spectrum, 57–64 GHz is used for short-range local area network with Gbps data rates. mmWaves are severely affected by atmospheric conditions such absorption from water vapors. As Oxygen molecules absorb EM waves at 60 GHz, the frequency range 57–64 GHz is severely affected in this range. The attenuation at this range can be 15 dB/km. Moreover, water vapors in atmosphere attenuate EM waves at 164–200 GHz range and attenuation can be in tens of dB/km (Wei et al. 2014).

2.2.7 Bluetooth (Collotta et al. 2018)

Bluetooth is a type of wireless ad hoc network. It has the features of robustness, low complexity, low power and low cost. It can exchange data up to 2 Mbps at short distance with 2.400–2.486 GHz band. Currently, it has gained significant momentum as a major pillar of IoT (Chang 2014). However, it faces major issue of security and privacy. Authentication and encryption are common features of Bluetooth connectivity.

2.2.8 Wireless Fidelity (WiFi)

WiFi is a wireless communication technology which refers to IEEE communication standards e.g. IEEE 802.11. It is based on frequency-hopping spread spectrum (FHSS) and direct sequence spread spectrum (DSSS). Different versions of WiFi have been proposed such as IEEE 802.11a operates on 5 GHz and offers 54 Mbps. IEEE 802.11b operates on 2.4 GHz and supports 11 Mbps, while IEEE 802.11n operates on 2.4 GHz and supports 5 GHz. Moreover, IEEE 802.11, introduced in 2014, improves data rate up to 1300 Mbps. 60 GHz high speed seamless connection has been demonstrated as well. WiFi technology can support localization as it proves ubiquitous connectivity. WiFi based indoor positioning systems are being used for location based applications (Yang and Shao 2015). WiFi technology has fostered several applications e.g. gesture recognition and adaptive communication. The major drawback in WiFi is accuracy and security. We have summarized advantages and major issues of various RF technologies in Table 8.

Table 9 shows different RF technologies, which have been employed in hybrid RF/optical wireless systems.

2.3 Overview of underwater wireless acoustic communication (UWAC) (Kaushal and Kaddoum 2016a; Zeng et al. 2017)

The past few years have witnessed a rapidly growing interest in underwater acoustic communication because of its wide range of applications including control capabilities, navigation, exploration of marine resources, remote sensing, oceanography, defense, data exchanges in underwater sensor networks, scientific data collection at ocean bed,

Table 8 Advantages and major issues of RF technologies (Li et al. 2016b; Wei et al. 2014)

RF technology	Advantages	Major issues
Femtocell	LOS and NLOS path Medium coverage area High QoS High network capacity gains Enhanced indoor coverage Better user experience	Limited capacity Spectrum limitation Interference management issue
Macrocell	LOW and NLOS path High coverage area High QoS User mobility	High cost Low data rate Spectrum limitation User interference
Microwave	High data rate Long distance	Microwave link drop EM interference Performance degradation by rain
Bluetooth	LOS and NLOS path Unlicensed spectrum Low cost Robustness Low complexity	Security Privacy High interference Limited range
WiFi	LOS and NLOS path Low cost Medium coverage area Unlicensed spectrum High data rate Ubiquitous connectivity	Accuracy issue Security High interference Low QoS

Table 9 Some RF technologies used in hybrid RF/optical systems

References	RF technology	Range (GHz)
Wang et al. (2017a), Wu et al. (2021a), Zeng et al. (2020)	WiFi	2.4/5
Bazzi et al. (2016)	DSRC	5.9
Liu et al. (2020), Kafafy et al. (2018), Abuella et al. (2020)	WINNER II	2–6
Obeed et al. (2018), Wei et al. (2014)	mmWave	60

underwater security surveillance, communications among submarines, offshore oil industry, marine commercial operations and ecosystem monitoring. Acoustic communication can transmit data in underwater environment up to 20 km. It is the only feasible and reliable technique for long-distance underwater communication for scientific and commercial scenarios. It also offers military surveillance to support AUVs or divers for long range survey and target or threat detection (Diamant and Lampe 2018). However, it faces low data rate, Doppler spread and severe multipath spread issue. Doppler modeling and resolution is regarded as one of the critical aspect in existing UWAC. Research fraternity is focusing on several topics including bandwidth efficiency improvement, Doppler scale, UWAC channel doubly spread mitigation and channel equalization for intersymbol interference (ISI) cancellation.

2.4 How hybrid system works?

A hybrid system is based on two or more networks. These networks are configured according to the network type and application scenario. If a hybrid system is based on two networks then any network can operate as uplink or downlink or both. The major concerns in hybrid systems are physical layer security, network selection, load-balancing, mobility, scheduling, uplink/downlink protocol and sharing of resources. A joint resource allocation mechanism can be designed to allocate bandwidth and power to each network. Several researchers have developed resource allocation techniques. Kafafy et al. (2018) presented resource allocation technique for bandwidth and power allocation. Zhou et al. (2017) formulated rate control and channel allocation for hybrid FSO/RF networks. Wang et al. (2017b) presented load balancing game for indoor hybrid RF/LiFi systems. They also presented dynamic load balancing in hybrid LiFi/WiFi networks (Wang and Haas 2015). Link switching analysis have been carried out in Hasan et al. (2018a) for hybrid LiFi/OCC systems. In a recent study, Zaman et al. (2020) reported hybrid networks as an excellent approach to achieve required level of service quality in 5G networks. Authors have briefly discussed opportunities and key research directions of hybrid networks. In Delgado-Rajo et al. (2020), hybrid RF/VLC architecture is presented for Internet-of-Things (IoT).

In hybrid networks, the uplink or downlink sharing is based on wireless technology type and application strategy. Since LED based receiver devices cannot operate with high power, so RF system is preferred as uplink in hybrid RF/optical systems. Both RF or optical system can be used for downlink communication. The OWC systems such as LiFi and VLC are used for high data rate. While RF downlink is used to reduce interference, to overcome NLOS and support handover. Feng et al. (2016) reported that there are three configurations for downlink communication in RF/optical hybrid networks such as VLC, mmWave and hybrid VLC/mmWave for downlink.

2.4.1 Optical network for downlink

It is the basic deployment configuration. In this case, OWC link independently performs downlink communication. In such networks, the performance of optical link depends on LOS misalignment but it can be managed by using propagation protocols, relay topology and channel coding schemes. Moreover, the optical link suffers from inter-symbol interference, multipath and shadowing.

2.4.2 RF as a backup of optical downlink

In this configuration, RF link operates as backup downlink communication. In this case, whenever optical link drops due to LOS misalignment, then RF backup link operates for data transmission. It provides uninterrupted communication as such places where optical LOS misalignment occurs frequently.

2.4.3 Simultaneous optical and RF systems for downlink

In this configuration, both RF and optical links simultaneously operate for the downlink communication. This strategy offers higher data rates. However, it involves complexity in traffic management. This strategy can be deployed in large capacity scenarios.

3 RF/optical wireless hybrid networks

The rapidly growing demand for high data rates overloads existing RF systems. Therefore, technologies like cognitive radios and mmWave have been widely used to mitigate capacity limitations and spectrum scarcity. In contrast, optical systems such as VLC links support high data rates with very high bandwidth. VLC is hazard free, low power consumption, low latency, reliable communication, free spectrum and interference free from surrounding EM sources. Recently hybrid RF/VLC systems have been designed to take benefit of the improved connectivity of RF links and high capacity of VLC links (Diamant and Lampe 2018). These hybrid RF/VLC systems are envisaged to enhance mobility and user experience. In parallel, it can optimize power consumption, interference and network capacity.

Different configurations of optical and RF technology can be implemented to form hybrid RF/optical systems. Table 10 summarizes hybrid RF/optical systems for different applications. Hybrid RF/optical systems are designed according to required application scenario. For example, if mobility and NLOS communication is required, then RF wireless system is developed. While in case of high throughput demand, optical wireless network is developed. Hybrid RF/optical systems are suitable for both indoor and outdoor conditions, including underwater and vehicular communications. In this section, we have presented different configurations of hybrid RF/optical systems.

3.1 Hybrid RF/optical systems in indoor applications

Currently, optical wireless technologies such as OCC, LiFi and VLC as well as RF-based technologies such as Bluetooth, femtocell, macrocell, WiFi are widely uses in indoor applications. In many indoor applications, multi-tier HetNets use a configuration of optical cells, which enable higher capacity through broad spectrum; WiFi and femtocells, which offer high coverage; and macrocells which offer low data rate and broad coverage. VLC and LiFi offer traffic offloading from macrocells and femtocells. Thus, RF/optical hybrid systems provide advantages of each technology and overcome limitations. Figure 5 shows possible ways for connectivity in RF/optical hybrid systems (Chowdhury et al. 2019a). Connectivity between source and destination can be established directly or using a relay. The optical link can be established through source-to-relay or relay-to-destination. The forward and return communication links will vary according to hybrid system type or application scenario. Another possible configuration is to share the forward and return paths. The optical link can use forward path while RF link can use return path in a hybrid system.

For indoor applications, RF is used for macrocell, femtocell or WiFi. As receiver device such as smartphone cannot operate with high power LEDs for uplink, so LiFi or VLC cannot provide good performance. In addition, OCC offers unidirectional communication; other directions can be designed by using RF, VLC or LiFi. Hence, LiFi and VLC are used to realize only uplink, downlink or both uplink and downlink communications. These hybrid network configurations offer improved throughput by improved link reliability, smart handover, reduced interference and load balancing.

3.1.1 Hybrid systems with RF-based small cells and WiFi

Several combinations of hybrid systems can be obtained by using OWC technologies with RF small cells and WiFi. The hybrid small cell/LiFi, RF/OCC, WiFi/LiFi, small cell/VLC and WiFi/VLC can enhance system performance. Both VLC and LiFi provide high

Table 10 Related studies on hybrid RF/optical systems (Li et al. 2016b; Wei et al. 2014)

References	Hybrid system type	Research contribution	Applications
Hasan et al. (2019a)	OCC/BLE	It discusses efficient, remote and real-time monitoring of electrocardiogram (ECG)	Remote patient monitoring
Wang and Haas (2015)	Microwave/FSO	It addresses potential solutions for uplink/downlink communication and backhaul connectivity in an optical attocell	Backhaul connectivity
Wu et al. (2021a)	LiFi/WiFi	It addresses unique challenges faced by HLWNets such as load balancing, handover, interference management and user behavior modeling. It also discusses role of HLWNets in physical layer security and indoor positioning	Load balancing, Interference management
Wang et al. (2017b)	LiFi/RF	It presented a load balancing strategy for LiFi/RF network. Proposed strategy improves user experience at low computational cost	Load balancing
Obeed et al. (2018)	VLC/RF	A new efficient algorithm is presented with faster convergence and better performance	Power optimization and load balancing
Liang et al. (2017)	VLC/femtocell	It contributes in handover decision-making through an algorithm in a hybrid VLC-femtocell system	Handover management
Delgado-Rajjo et al. (2020)	RF/VLC	The main contribution of this work is to design a hybrid RF/VLC system which allows inter-operability between different technologies for IoT applications	Coverage in remote areas, localization
Zhou et al. (2017)	FSO/RF	It presents rate control and channel allocation for hybrid FSO/RF vehicular networks	Vehicular networking
Abuella et al. (2020)	RF/VLC	A novel bandwidth and power allocation scheme for power efficient hybrid RF/VLC indoor systems	Power optimization
Armon (2010)	RF/FSO	Considering water type, LOS and NLOS path, a suitable network architecture between RF and optical technology is designed	Backhaul connectivity, link reliability

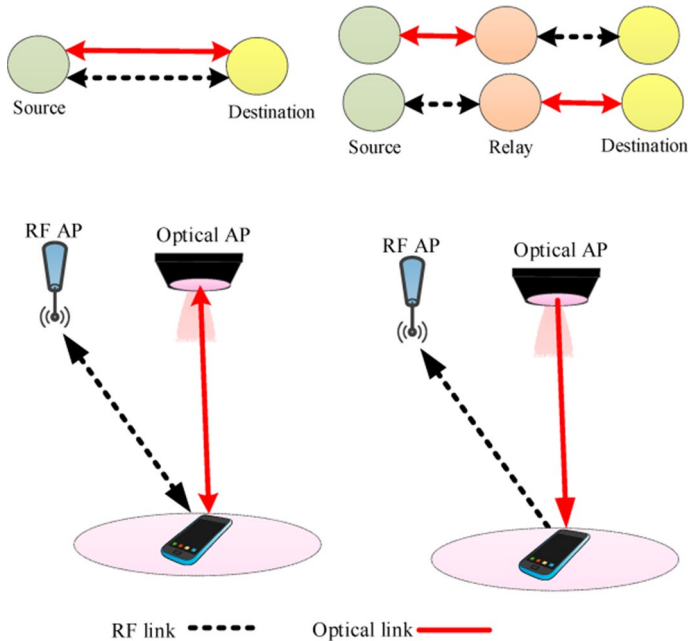

Fig. 5 Few possible ways of connectivity using optical and RF hybrid systems (Chowdhury et al. 2019a)

data rate, while RF small cells and WiFi support wide coverage. RF networks can provide smooth handover.

3.1.2 Hybrid systems with macrocells

Macrocell/LiFi and macrocell/VLC system enhance the QoS. VLC and LiFi provide high data rate and low mobility, whereas macrocells serve for higher QoS and higher mobility. Therefore, macrocell/LiFi and macrocell/VLC support high data rate and ensure traffic offloading to provide seamless connectivity, link reliability and improved spectral usage. LiFi and VLC enable traffic offloading in macrocellular network to improve energy and spectral efficiency.

3.1.3 Network selection in indoor RF/optical hybrid systems

The following criteria should be considered for the selection of an appropriate hybrid network:

3.1.3.1 Uplink/downlink transmission In an indoor scenario, networks are assigned on the basis of uplink and downlink types. Generally, optical downlink offers high data as compared to optical uplink. LiFi and VLC networks provide higher data rates as compared to RF networks. Thus, LiFi and VLC can be considered for downlink communication while RF networks are preferred for uplink communication. Consequently, interference can be reduced by traffic offloading from RF to optical networks.

3.1.3.2 Traffic type Few applications such as banking and real-time audio transmission need low data rates with high QoS. On the other hand, video streaming requires high data rates and low QoS. Thus, an appropriate network can be developed according to the traffic type as both OWC and RF support different QoS levels.

3.1.3.3 Security Secure data transmission is an important feature in network selection. As light cannot penetrate through walls, so optical wireless network based information cannot be hacked by outside users.

3.1.3.4 LOS/NLOS In NLOS conditions, optical wireless networks do not offer reliable communication. While RF networks can support reliable communication in such conditions. Thus, LOS/NLOS plays an important role in network selection.

3.1.3.5 Mobility support RF networks can be selected for those applications, which require significant mobility support, whereas optical networks can be used in those services, which do not require mobility support.

3.1.4 Advantages of Indoor Hybrid Optical/RF Systems

The indoor hybrid systems have several advantages for network users. A few of them are listed below:

3.1.4.1 Traffic offloading Traffic offloading to LiFi and VLC can improve the performance of RF based small cells, macrocells and WiFi (Ayyash 2016). The network performance degrades when multiple users share the limited bandwidth. Applications which demand high QoS can be supported by RF networks while LiFi or VLC can be used to support application requiring low QoS. Hence, bursty nature of traffic can be overcome by offloading from RF to VLC or LiFi.

3.1.4.2 Improvement of link reliability Link reliability can be improved by two or more networks. VLC/macrocell, VLC/small cell, VLC/WiFi, LiFi/ macrocell, LiFi/small cell and LiFi/WiFi (Wu et al. 2021a) hybrid networks develop two-tier networks which increase link reliability.

3.1.4.3 Improving seamless connectivity RF/LiFi and RF/VLC hybrid networks offer seamless connectivity. In indoor services, RF macrocells, small cells and WiFi provide high coverage. Thus, RF technologies can enable seamless connectivity between optical networks with coverage holes.

3.1.4.4 Energy efficiency An optical wireless system consumes low energy as compared to RF system because optical sources such as LEDs are used for illumination with low energy consumption. In case of traffic offloading from RF to optical, energy consumption can be significantly reduced.

3.1.4.5 Interference reduction Interference level is significantly decreased in indoor RF/optical hybrid networks as both individual networks do not interfere each other. If any user is

severely affected by interference then it can be served through another less affected network or traffic offloading.

3.2 Hybrid RF/Optical systems in vehicular communication

Recently, research fraternity has given significant attention to vehicular communication such as vehicle to-roadside units (V2RSU) and vehicle-to-vehicle (V2V) communication (Peng et al. 2018). RF systems have been used for vehicular communication for a long time. However, RF networks suffer from scarcity of available resources and enormous interference which limits RF-based vehicular communication (Boulogeorgos et al. 2015). RF coverage area in vehicular communication can be extended by using cooperative wireless communications (Osman et al. 2019). However, link reliability is yet to be explored in vehicle-to-everything (V2X) communications (Căilean and Dimian 2017; Ghosal and Conti 2020; Takai et al. 2014; Wang et al. 2019; Zhou et al. 2020). Nowadays, researchers have started focusing to employ cognitive radio frequency (CRF). CRF is an intelligent technology which can improve mobility and scarcity of RF resources (Liu et al. 2016). CRF works on the basis of spectrum sharing to overcome congestion issue in RF spectrum. However, dynamic and complex nature of CRF system incurs challenging issues of power consumption and reliability. Recently, researchers have deployed OWC systems to remove these limitations in indoor and outdoor environments. OWC technologies such as VLC has many benefits in V2X communications as it offers secure data transmission, free spectrum, low power consumption, ubiquitous connectivity and no interference from nearby RF devices (Cheng et al. 2017). Nevertheless, VLC based vehicular communication has a critical drawback of LOS in V2V communication at long distances (Memedi and Dressler 2020).

Currently, global positioning system (GPS) is commonly used to track vehicles. However, GPS is expensive and cannot provide significant services in underground and tunnels. In such cases, hybrid RF/optical wireless system can be used as a good complementary choice to the GPS system. Chowdhury et al. (2019b) briefly discussed hybrid RF/optical wireless systems for transportation applications. In their proposed network, OCC system is installed with an overhead traffic signal. The camera attains the identity (ID) of vehicle approaching in a communication range. This ID, vehicle distance and location information of infrastructure is sent to server for precisely locating the vehicle. The user can access this information by any smart device and can find the location of vehicle. WiFi or LiFi connectivity can be considered to provide location information at any bus stop. Similarly, this system can also track train without using GPS. The application scenario of hybrid RF/optical system can be seen in Fig. 6.

OWC convergence with RF can significantly improve link quality. OWC with 5.9 GHz RF dedicated short-range communications (DSRC) can provide a long distance communication. On the other hand, other OWC technologies except FSO cannot provide such distance but can be considered for high dense traffic regions. VLC can be used for very short distances, while OCC can be used for distance up to 60 m and FSO can be used for long distance communications (Luo 2015). In addition, VLC can also be used to transmit information at a longer-distance in a multi-hop manner.

Al-khori et al. (2019) used Decode-and-Forward Relaying (DFR) technique for security purpose in hybrid RF/VLC system. They used zero-force beaming technique to design proposed hybrid RF/VLC system and used security algorithms to remove eavesdropping. However, there is still a gap to improve the efficiency and throughput of the vehicular

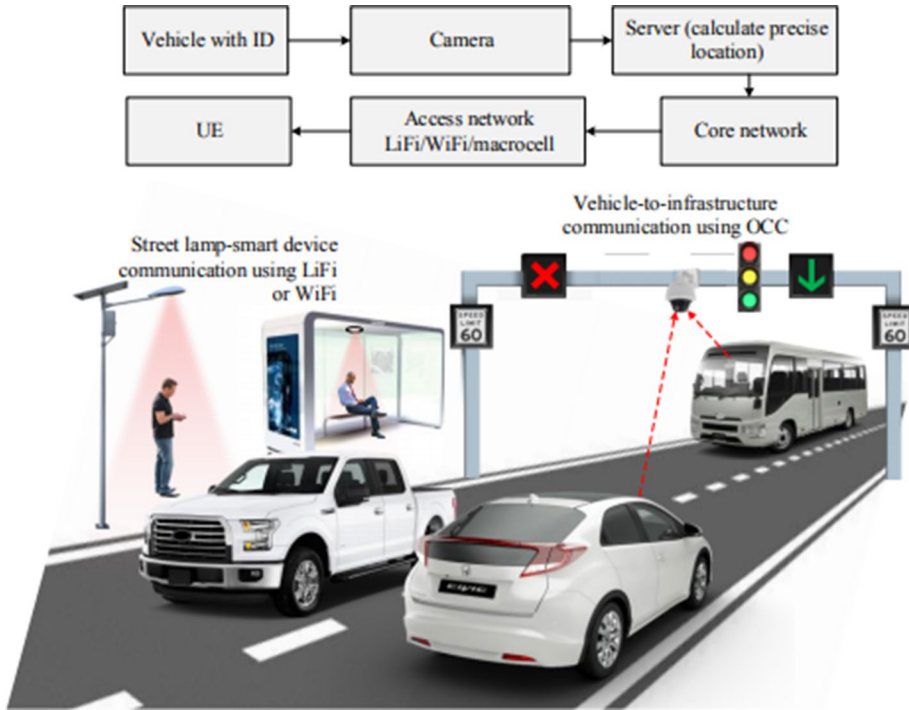

Fig. 6 Hybrid RF/optical network for vehicle tracking (Chowdhury et al. 2019b)

communication. Recently, Abouzohri et al. (2020) have presented a hybrid cognitive radio frequency (CRF)/VLC system for V2V communication to optimize existing solutions to enhance efficiency. This novel approach is based on a decode-and-forward based hybrid CRF/VLC system in vehicle-to-vehicle communications (V2V).

Every vehicle on road transmits certain information to other vehicles or destination by using nearest macrocellular base station (MBS). A hybrid RF/optical system can be designed for such connectivity among moving vehicles. However, this system is challenging due to dynamic weather conditions and mobility of transmitter and receiver. The hybrid system can provide V2X and better QoS in outdoor vehicular communications. The main advantages of such hybrid systems are link reliability and traffic offloading. The performance of congested RF system can be improved by offloading traffic to optical VLC. As interference from nearby RF devices also degrades the performance of RF system, traffic offloading can also mitigate this issue. In terms of link reliability, the link drop ratio in harsh environment such as high dense traffic regions or NLOS condition can be reduced by hybrid systems. Some important parameters such as distance, weather, LOS/NLOS must be kept into account for hybrid RF/optical systems. Optical systems highly suffer from dust, fog, rain and nearby lights. Thus, environments conditions must be kept into account in selection of appropriate network for hybrid RF/optical systems. The consideration of communication distance is an essential parameter in selection of hybrid RF/optical system as VLC based LED can support short distance communication, whereas OCC supports medium range communication and FSO system supports long distance communications. Similarly, LOS/NLOS condition is also important for network selection in hybrid

RF/optical systems as some optical systems such as FSO require precise pointing between the transmitter and receiver.

3.3 Hybrid RF/optical systems in free-space

FSO has become a promising solution for wireless communication systems due to its key advantages such as license-free spectrum, high data rate, low-cost deployment and extremely high bandwidth (Pesek et al. 2018; Dahrouj et al. 2015; Huang and Safari 2020). However, FSO systems suffer from visibility issue under atmospheric conditions such as dust, snow, fog, scintillation, smog and atmospheric turbulence. Precise pointing and LOS conditions also introduce critical limitations. Earthquake vibrations, dynamic wind and thermal expansion cause misalignment between FSO transmitter and receiver. On the other hand, the performance of RF systems deteriorates in rain. RF frequencies below 10 GHz suffer from fog while frequencies above 10 GHz are highly affected by scattering. Thus, a hybrid FSO/RF system can be a complimentary solution to overcome limitations of each technology. The hybrid FSO/RF systems can ensure link reliability under harsh weather conditions. In an FSO/RF hybrid system, FSO and RF systems are used as primary and secondary backup networks respectively. These hybrid systems can be used for reliable distant communications e.g. ship-to-ship, airplane-to-airplane, airplane-to-ground, airplane-to-satellite, satellite-to-airplane, earth-to-satellite, satellite-to-earth and inter-satellite (Khalid et al. 2019).

Figure 7 shows an overview of hybrid RF/FSO system deployment. Such hybrid systems are used to enhance network reliability. Authors in Khalid et al. (2019) analyzed wireless network with hard switching between RF and FSO links. It is assumed that data is transmitted with hard switching either RF or FSO on the basis of circumstances such as

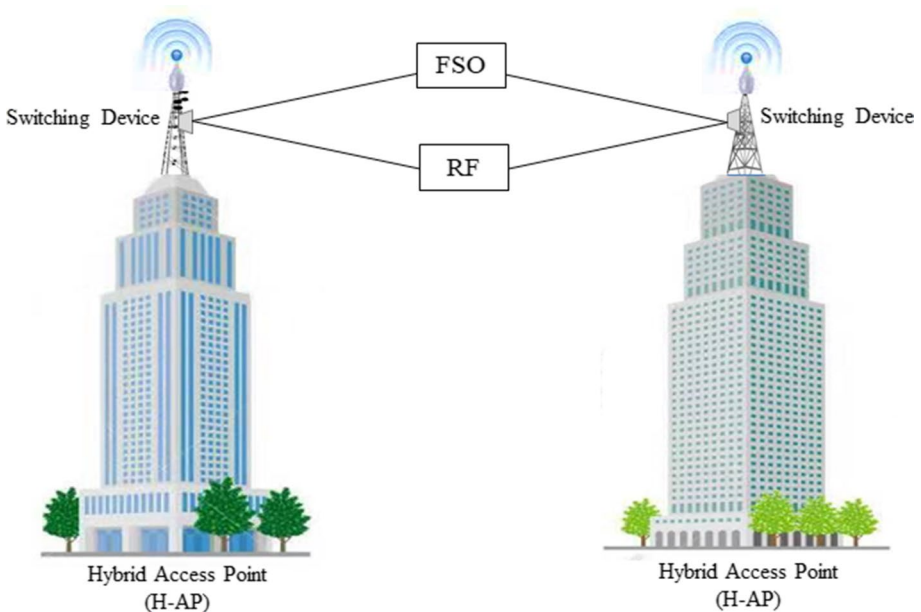

Fig. 7 An overview of hybrid FSO/RF system

only one link will operate at a certain time. For a certain time when SNR of FSO link remain above a defined threshold level then FSO link keep operating. As SNR of FSO link falls below a specific threshold level then RF link is activated. For simplicity, authors have assumed that at least one link keep operating at a certain time and system does not interrupt the complete hybrid RF/FSO network. As only one link operates at specific time so power consumption is reduced and receiver design will be simpler. This switching mechanism in hybrid RF/FSO network is efficient and provides better performance in terms of reliability and availability as compared to single FSO model. An important advantage of such system is to maintain link under harsh environmental conditions. Under dynamic atmospheric condition, network selection plays a crucial role in hybrid RF/FSO connectivity. Several studies have been reported to address performance and capabilities of hybrid FSO/RF systems. Nadeem et al. (2009) studied effects of weather conditions on hybrid FSO/RF links. They experimentally demonstrated hybrid FSO/RF system to find real-time measurements of attenuation. In Touati et al. (2016), atmospheric fading and misalignment effects are studied as these are dominant factors for FSO link failure. In Khan et al. (2021), authors have presented a comparative analysis between adaptive and non-adaptive systems. They have recommended adaptive hybrid FSO/RF approach as an optimum solution for different weather conditions. In Rakia et al. (2015), adaptive combining approach is used to retrieve original data from two links at receiver and machine learning approach is used in Haluška et al. (2020) to find received optical power.

3.4 Hybrid RF/FSO backhaul solutions for next generation wireless systems

The growing demand of data rate in current networks possesses a cost burden on backhaul design. Designing a cost-effective and high bandwidth backhaul solution is a challenging issue in defense and commercial applications. In 5th generation, backhaul links are increased due to higher traffic capacity. In order to support 5G, researchers are finding unique solutions for 5G capacity, latency and networking challenges. In finding any promising solutions, we have to consider distance, link reliability and capacity at the same time. Such as, low frequencies suffer from multipath propagation while higher frequencies are affected by rain attenuation. Mostly existing backhauls links are below 7 km and throughput is around 20 Gbps. Moreover, capacity requirements also impose limitation in backhaul connectivity. Available spectrum limits network capacity and higher order modulation schemes to enhance spectral efficiency but it also possess limitation in communication distance. Thus, appropriate backhaul connectivity is required, which can support both with ease. Some studies have presented backhaul network including either optical fibers or radio frequency. RF offers low data rates and it is a cost-effective solution. In addition, free-space optical (FSO) communication is low cost and supports high data rates. However, FSO systems are sensitive to atmospheric conditions e.g. fog, rain and line-of-sight (LOS). Some studies have proposed cost-effective hybrid RF/FSO solutions by combining low-cost, easy deployable and NLOS based RF with high data rate, low latency FSO backhauls (Dahrouj et al. 2015; Douik et al. 2016). NLOS RF backhaul has scalability and cost advantages but it suffers from low data rate, high latency and it incurs delay. Different techniques have been used in mobile backhauls such as mmWave, microwave, optical fiber cables and copper lines. One prevalent solution is low latency FSO backhauls. FSO transmission can be carried out by using laser beam between two LOS PDs. The typical wavelength of FSO laser beam is 850 nm, 1300 nm or 1550 nm which is license and EMI free. FSO communication uses modulated collimated beam which has several key features

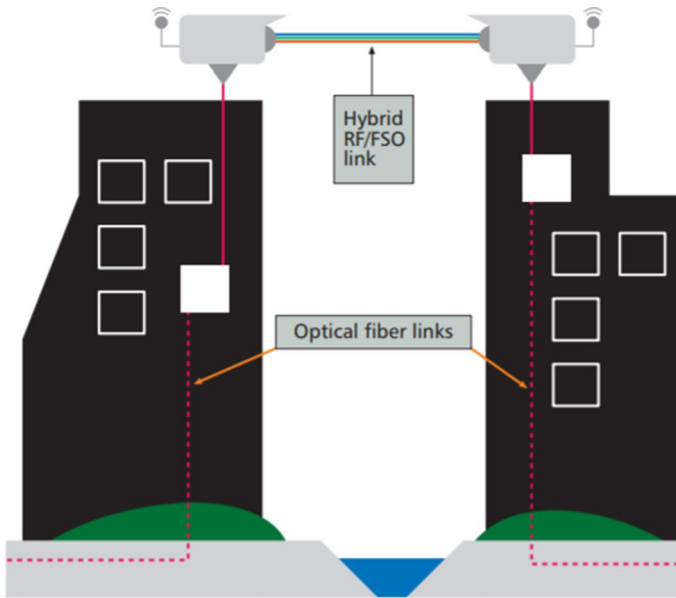

Fig. 8 An overview of hybrid RF/FSO backhaul (Dahrouj et al. 2015)

including low probability of intercept, high level of security, and high bandwidth capability (Graceffo et al. 2019). LOS RF/FSO mitigates latency as compared to optical fiber. Hybrid RF/FSO can switch to RF or FSO according to weather conditions. In addition, multiplexing techniques e.g. wavelength-division multiplexing (WDM) can be used to improve data rate up to 10 Gbps. Hybrid RF/FSO can be installed quickly, which makes it suitable for upgrading network. Hybrid RF/FSO has several advantages in terms of data rate, reliability and connectivity constraints. An overview of resilient strategy of hybrid RF/FSO backhaul is shown in Fig. 8 where a wired connection is challenging between two buildings because of river. A network strategy composed of two optical fiber (OF) links and a hybrid RF/FSO link is shown in Fig. 8 (Dahrouj et al. 2015). FSO laser beam has a wavelength in micrometer range which is an unlicensed band and immune to EM interference by RF devices. As FSO is a wireless technology so there is no need for any additional digging which is a challenging issue in the deployment of OF from both time and cost perspectives.

3.5 RF/optical wireless hybrid in eHealth

In recent years, a dramatic increase has been witnessed in electronic healthcare (eHealth). Modern hospitals have started adopting eHealth as a complementary solution to the traditional medical services. eHealth is based on IoT applications, characterized by its minimal human assistance in nursing, improved reliability, high capacity communication, radiation-free, locatable and cost effectiveness. eHealth includes a range of services such as health knowledge management, electronic medical records and telemedicine. Mostly medical experts emphasize on human healthcare system with good monitoring system (An et al. 2017; Hasan et al. 2018b). A good monitoring system must be secure, reliable, low cost and low power in intensive-care environments. Wearable patch antenna or sensing devices

are important for any potential eHealth solution. Wearable sensing network has shown potentials in remote monitoring of patient.

In healthcare systems, communication is carried out by RF-based BLE technology. However, existing RF technologies have several drawbacks in eHealth solutions including high SNR and severe electromagnetic interference effects, which can cause malfunctioning in some medical devices. The effect of RF on human skin is also a major concern. SNR ratio in long distance can be decreased but it increases BER. Optical camera communication is an alternative solution for sensors-to-access network connectivity. It uses a camera to collect data from an LED which reduces the limitations of RF. The only limitation of this system is high signal-blockage probability. Thus, in future eHealth systems, a hybrid approach of OCC and BLE can be a possible solution for real-time monitoring. Hasan et al. (2019a) proposed a hybrid OCC/BLE system to ensure remote, efficient and real-time transmission of human ECG to a monitor. Body sensors such as electromyography (EMG) sensors, glucose level, blood pressure (BP), oxygen saturation and electroencephalogram (EEG) gather data from different body parts. These sensors are linked with a skin patch with integrated OCC and BLE module (Hasan et al. 2019a). This patch is linked with BLE and a camera for required RF and OCC connectivity. The hybrid BLE/OCC system is used for remote monitoring of patient (Hasan et al. 2019a; An et al. 2017). Different body sensors are used to remotely measure patient's health conditions. This information is gathered by a hybrid BLE/OCC system which helps medical expert to monitor patient remotely. In addition, a hybrid RF/OCC system is used to monitor a wheelchair-bound patient (Chowdhury et al. 2020). A wearable skin patch is used to collect patient's body conditions. Collected information is provided to a satellite network linked with a core network for remotely monitoring. Hybrid RF/OCC systems can also be used to provide remote medical assistance in an ambulance. A hybrid BLE/OCC system is mounted in ambulance

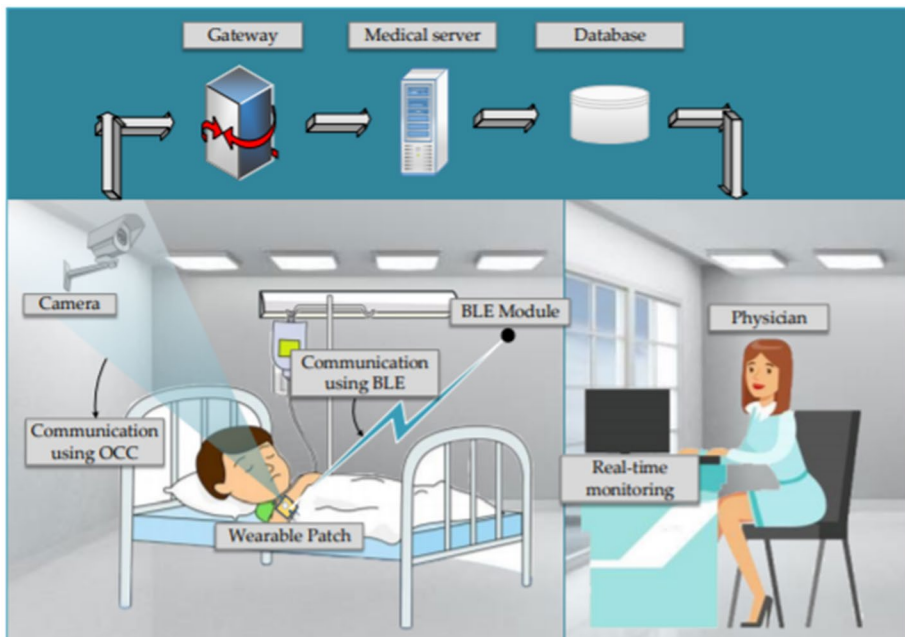

Fig. 9 An overview of hybrid BLE/OCC healthcare monitoring system (Hasan et al. 2019a)

which is connected to satellite network for remote monitoring (Chowdhury et al. 2020). In such cases, a fast and reliable link with lowest interference for real-time monitoring is required. The main aspect to select an appropriate network in hybrid BLE/OCC system is LOS/NLOS condition. A remote monitoring system based on OCC is shown in Fig. 9. In this system, a BLE receiver is used to collect the data from patch. The collected data is then processed to recover the original signal, and then it is sent to gateway for remote transmission. eHealth server is used for data storage which it can be accessed from eHealth database. In this system, cameras can operate by the rolling shutter method. Thus, whenever network access request (NAR) is made, the data is transmitted through BLE or OCC. In Chowdhury et al. (2019b), authors have briefly explained the advantages of OCC system for simultaneously data collection from multiple sensors and monitor the patient. As RF technologies cause EM interference and it is harmful to patients. Therefore, an OCC system can be installed in an ambulance where a patient crucially needs monitoring while moving from place to another. OCC system receives the monitored data from wearable sensors. This collected data is sent to doctors or hospital through macrocellular network. In this way, patient's conditions can be monitored and patient can get treatment by remote doctors. Table 11 illustrates some existing healthcare monitoring systems discussed in literature.

3.6 Hybrid FSO/RF systems as received signal strength identifier (RSSI)

Hybrid FSO/RF system can be used for hard switching from FSO to RF link and back by using prediction analysis based on received signal strength identifier (RSSI). Research fraternity has focused on design and implementation of a monitoring device to predict weather information as atmospheric conditions significantly impair atmospheric channel transmission and adversely affect optical communication. Renat Haluska et al. (2020) practically demonstrated hybrid FSO/RF monitoring system as a solution for high availability of optical link. Authors used machine learning methods with regard to the amount of received optical power.

The mutual interaction of optical beam with aerosols can reduce transmission speed or causes full interruption in communication. It means the amount of received optical signal at receiving component such as the avalanche photodiode (APD) decreases due to scattered particles in communication channel (Taher et al. 2019). In FSO communication, the major problem is fog as its concentration and size causes severe attenuation in transmitted optical signals. By choosing appropriate mechanism to predict harsh weather conditions, it is possible to switch FSO link to RF link. RF link has low sensitivity to fog, but RF based communication is degraded by rain. Efficient switching between FSO to RF backup line can be successfully implemented after identifying the atmospheric conditions on the basis of received optical power (Katsilieris et al. 2017). In Halaška et al. (2020), researchers used machine learning methods e.g. decision-tree regression, gradient-boosting regression and random forest for reliable prediction and identification of received optical power, thereby enhancing both reliability and availability of FSO/RF hybrid systems. The experimental system of monitoring device is shown in Fig. 10. It is used to monitor weather along the transmission path between two FSO heads during determining and evaluating availability and reliability of FSO system. It can also monitor temperature in the vicinity of FSO transmitter and receiver which is related to atmospheric turbulence which is caused by abrupt change in temperature

Table 11 Summary of existing healthcare monitoring systems in literature

References	Technology	Research work	Applications
Ding (2015)	Hybrid power line and VLC	This study proposes hybrid power line and VLC system for indoor hospital applications	Indoor hospital applications
Rachim and Chung (2016)	BLE	To develop a low-power, reliable, mobile and robust system for ECG monitoring	ECG
Spanò et al. (2016)	ZigBee	To develop a low-power remote ECG monitoring system	ECG
Cheng and Zhuang (2010)	BLE	To use BLE for patient location detection, movement pattern to determine Alzheimer's disease	Detection of Alzheimer's disease
Milici et al. (2018)	BLE	To develop a low-power, reliable magnetometer sensor for sleep quality monitoring	Sleep
Tseng et al. (2013)	GSM and BLE	To develop a wearable mobile electrocardiogram monitoring system to check user's ECG continuously	ECG
Lopez-Ruiz et al. (2015)	BLE	An optical luminescent sensor-based wearable system to monitor oxygen concentration in breath	Oxygen concentration in breath
Wu et al. (2019)	Bluetooth-based medical signal sensing network	This study highlights a wearable sensor network system for IoT-connected safety and health applications	IoT-Connected Safety and Health Applications
Brugarolas (2015)	Optical fibers and light guides	To design a wearable heart rate sensor system to monitor canine health and dog's behavior response	Canine health monitoring
Kim et al. (2015)	ZigBee, WiFi	To develop a telemonitoring system based on coexistence of ZigBee-based WBAN and WiFi	Health telemonitoring
Nemati et al. (2012)	ANT	To design an effective, small size and low power ECG sensor	ECG
Tabish et al. (2014)	3G/WiFi, 6LoWPAN	To provide resilient and flexible technological solutions for remote monitoring of patients health condition in real-time	Ubiquitous healthcare (U-healthcare) systems

Fig. 10 Monitoring system (Haluška et al. 2020)



and pressure along the transmission path of FSO signals. Monitoring and detection of fog particles can also be realized in this system by using a simple optical sensor. Some important concerns in design of such monitoring device are data collection, processing and backup after regular measurements. Measuring variation in the concentration of particle can play a key role to solve the problem of early optical backup to provide high availability. Additionally, calculating wind speed during analysis of the FSO system availability is important to identify the occurrence of optical turbulence between

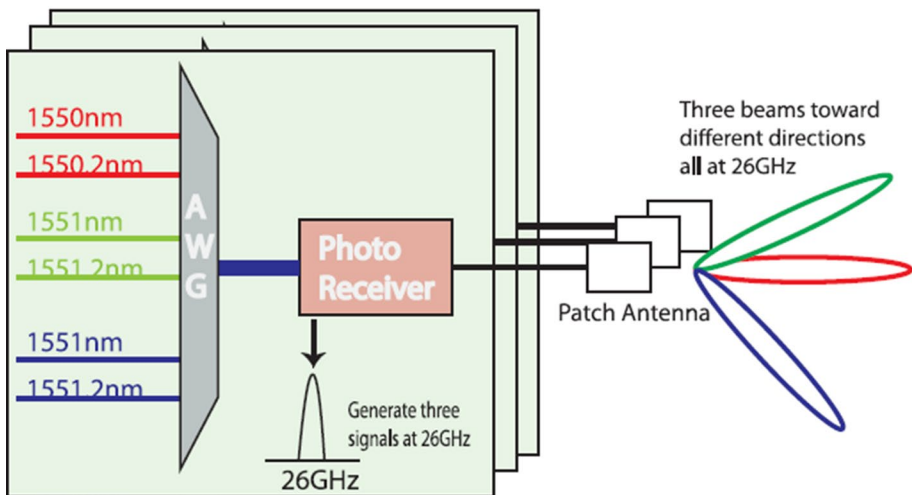

Fig. 11 Three mmWave beams generation using the ERON architecture (Lu et al. 2020)

transmission path of FSO transceivers. A microcomputer is used after considering price, dimensions and open operating system to analyze the reliability of availability of FSO system. Such monitoring system can provide visibility measurements through a mini optical fiber sensor (miniOFS). This system also provides measurements for humidity level which affects FSO link.

3.7 Elastic RF-optical networking (ERON) for mmWave 5G networks (Lu et al. 2020)

The hybrid RF and optical or photonic technology is a promising solution for fifth generation wireless networks. Optical signal processing techniques have been investigated to contribute to the mmWave 5G networks. Power consumption analysis should be carried out towards an optical solution for mmWave 5G networks. Similarly, microwave optics is a hot research domain, which applies optical technologies to microwave applications (Marpaung et al. 2019). Li et al. (2019) demonstrated radio-over-fiber (RoF) for mmWave communication. Recently, Hongbo Lu et al. (2020) introduced ERON by using photonic-enhanced multibeam mmWave spatial multiplexing to achieve throughput elasticity and energy efficiency as shown in Fig. 11. The convergence of RF and optical resources provide high resource pooling gain and resource usage flexibility. Authors validated that ERON is five times more energy efficient than traditional RF implementations. ERON offers promising solution for the crunch resource requirement challenges, the surging fronthaul link capacity challenges and mmWave power consumption challenges. Energy efficiency is a key benefit for using photonic signal processing for mmWave beamforming. ERON utilizes optical technologies to assist mmWave communications. Smart photonic resource allocation can be implemented through efficient photonic signal process techniques. In future, photonic research innovations can contribute in technologies for the mmWave 5G deployments to serve fronthaul communication.

3.8 The hybrid systems for aeronautical and space applications

Researchers from Glenn Research Center of National Aeronautics and Space Administration (NASA) (NASA Technology Transfer Program [Online]. xxxx) have designed a hybrid telescope antenna names as Teletenna for high data rate communication over longer distances. Teletenna enables communication on earth and deep space missions. It integrates RF and optics together to overcome engineering challenges and capitalizes on the advantages of each technology. It revolutionizes Deep Space Optical Communications (DSOC) by 10 to 100 times real-time data transfer, live video feed and to deliver high-definition

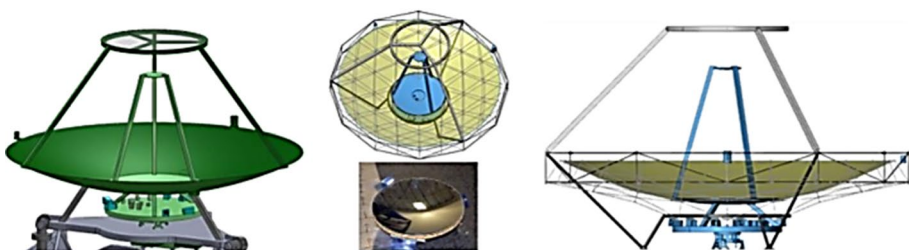

Fig. 12 Teletenna concepts (Raible et al. 2014)

(HD) imagery. It is lightweight, robust, reliable and offer exceptionally precision to revolutionize aerospace, secure communication for aircraft, telecommunication and satellite communication. Initially, it was designed for missions to Mars. It can offer data rate 84 Mbps RF and 267 Mbps optically at Mars' closest approach (Raible et al. 2014). It integrates Ka-band RF antenna and co-boresighted telescope. It has a Cassegrain geometry as shown in Fig. 12. This geometry was designed to reduce system mass for deep-space applications. It provides maximum stability by isolating RF reflector from optics thermally as well as mechanically.

In 2020, NASA started a project titled “Robust and High-Data-Rate Hybrid RF/Optical Communications for Lunar Missions” (Oklahoma State University News [Online]. xxxx) for next generation space-based communications. The Hybrid Lunar Communication (LunarCom) project is led by researchers from Oklahoma State University and includes research team from University of Tulsa and University of Oklahoma. This project will tackle low data rate and reliability challenges of RF systems by integrating both RF and optical elements in a smart framework. Researchers investigated critical challenges of NASA's communication systems and proposed this hybrid RF/optical system based project to support rapidly growing scientific data in NASA's lunar missions. LunarCom Architecture will integrate reliability of RF links with low cost and high capacity optical links to enable communication between earth stations and moon explorers.

German Aerospace Center DLR's Institute of Communications and Navigation (IKN) holds a remarkable place in developing FSO terminals for flying platforms such as small satellites, aircraft and stratospheric balloons(DLR Institute of Communications and Navigation [Online]. xxxx). Recently, innovators from DLR's research group have demonstrated a hybrid FSO/RF system under VABENE project to overcome the adverse atmospheric effects on communication. It aims to monitor and manage traffic under natural disaster and mass events. In this hybrid system, optical communication system designed by IKN is integrated with a HD camera sensor developed by the Institute of Remote Sensing (IMF). The possible implementation concepts and experimental results for this hybrid FSO/RF system

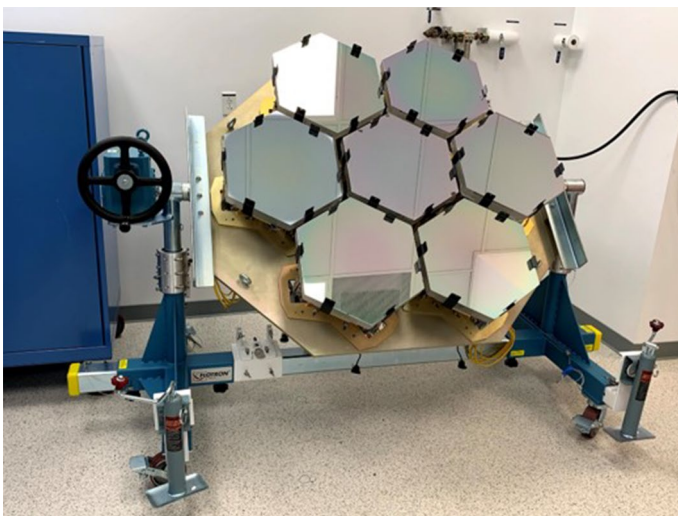

Fig. 13 Telescope design (Mohageg et al. 2020)

based on airborne, optical downlinks at 1Gbps are presented in a recent study (Rödiger et al. 2020).

In another project for deep space networking, researchers from California Institute of Technology have developed a hybrid RF/optical telescope (Mohageg et al. 2020). Authors have illustrated NASA's deep space network (DSP) to modify it by integrating an optical communication terminal (Charles et al. 2011) to meet future communication demands and mitigation of solar induced damage. Optical communication link will improve the capacity of deep space network (DSN). However, optical communication link between DSN transmitter and earth based receiver is restricted by sunlight. In some conditions, sunlight can fully block line-of-sight (LOS). The hybrid RF/optical telescope as shown in Fig. 13 can support high data rate optical links over solar system range. The system model has the capability to compute data rate and BER for optical communication under different link configurations. It considers various aspects including timing errors, background noise, detector noise, telescope efficiencies and atmospheric effects. It is designed to predict the performance of Optical Payload for Lasercomm Science (OPALS) mission (Abrahamson et al. 2015).

4 Acoustic/RF and acoustic/optical hybrid networks in underwater

In recent years, there has been a growing interest in wide range of applications such as climate change, offshore investigation, environmental monitoring, monitoring oil rigs, autonomous operations, localization, positioning and surveillance (Saeed et al. 2018; Cox

Table 12 Basic difference among UWC technologies (Mehedi et al. 2020)

Characteristics	UOWC	Acoustic	Radio frequency
Performance Parameter	Scattering, Absorption	Pressure, Salinity and temperature	Permittivity, permeability and conductivity
Transmission power	Few watts	Tens of watts	mW to hundreds of Watts
Bandwidth	10–150 MHz	1000 km < 1 kHz and 1–10 km \approx 10 kHz and < 100 m \approx 100 kHz	MHz
Latency	Low	High	Medium
Attenuation	0.39 dB/m Ocean	0.1–4 dB/km	3.5–5 dB/m
Size of antenna	0.1 m	0.1 m	0.5 m
Data rate	Gbps	Kbps	Mbps
Efficiency	30 kbits/Joules	100 bits/Joules	–
Speed	2.2×10^8 m/s	1500 m/s	2.2×10^8 m/s
Frequency band	10^{12} – 10^{15} Hz	10–15 kHz	20–300 Hz (ELF)
Distance	10–100 m	Up to km/s	Up to 10 m
LOS/NLOS	Only LOS	Both	Both
Confidentiality	Good	Bad	–
Equipment cost	Low	High	High
Equipment volume	Large	Large	Little

et al. 2020; Jaffe 2014). These applications require an efficient, reliable, high speed and long distance communication technique in underwater environment. Some research studies have focused on low-frequency RF, optical and acoustic underwater wireless communications (Kaushal and Kaddoum 2016a; Zeng et al. 2017; Saeed et al. 2019b; Mehedi et al. 2020). Table 12 summarized basic differences among these underwater communication technologies (Mehedi et al. 2020). RF and acoustic technologies are suitable for NLOS scenarios; however, they are prone to high power consumption and low data rates. Acoustic communication can provide transmission distance up to 20 km and it is widely used in underwater environment (Alimi et al. 2017). However, the data rate of this communication technique is in kbps only. Acoustic communication has some drawbacks such as high power consumption, high latency, high cost and negative impact on marine species. On the other hand, UOWCs allow high-speed underwater communication within a limited range (Schirripa Spagnolo et al. 2020). 405 nm blue LD is envisaged to provide long distance UWC as authors in Wang et al. (2016) established 20 m long underwater communication link with 1.5 Gbps data rate by using on-off keying (OOK) modulation. Generally, optical systems provide Gbps data rate within 10 to 100 m transmission range. The key advantages of UOWCs are low deployment cost, low complexity, high data rate, high security and lowest link delay. However, the performance of UOWC system degrades in NLOS scenarios as precise pointing between transmitter and receiver is required. Moreover, UOWC systems face recurrent communication failure due to scattering, absorption, seawater effects, misalignment and channel turbulence. Recent research studies have focused on increasing both transmission range and data rate of UOWCs (Retamal 2015; Tian 2017). Methods proposed in James Singh, et al. (2020), Wei (2020) enhance UOWC data rate by using LEDs. However, the transmission distance is limited in these studies. Alternatively, hybrid systems based on acoustic and UOWC are introduced to overcome the limitations of data range and transmission distance (Zhang et al. 2020b; Han et al. 2014, 2019; Wang et al. 2017c). Different configurations of hybrid systems are possible including RF/acoustic, RF/optical and RF/acoustic/optical systems. The key advantages of hybrid systems are improved link reliability and traffic offloading and increased capacity. In RF/optical hybrid system, high data

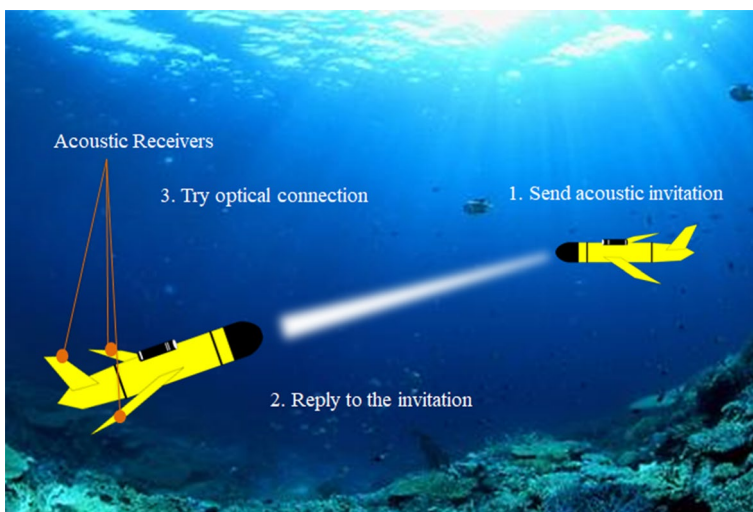

Fig. 14 An overview of hybrid underwater acoustic/optical wireless system

rate communication can be achieved for both short and long distance range. Similarly, high data rate LOS services can be achieved in hybrid acoustic/optical systems. The important parameters to select any suitable hybrid configuration are precise pointing of optical link, traffic type and communication distance. An overview of hybrid underwater acoustic/optical wireless network is displayed in Fig. 14. This system offers real-time video monitoring between AUV and base station (Mehedi et al. 2020). In this system, noted are equipped with optical and acoustic modems to enable advantages of both media by providing bandwidth and connectivity requirements. Moreover, additional acoustic receivers are equipped to enhance the communication redundancy along with providing additional data to localize another transmitter and align the optical modems. During alignment process, data is transmitted through acoustic link until the optical modems are aligned accurately. As the optical modems are aligned, video data is sent using optical links to exploit the increased bandwidth. The acoustic link keeps operating to exchange control signals and video frames are sent even if optical links are not available. Such hybrid acoustic/optical system can be configured dynamically and it can maintain high speed optical links. The control mechanism is fully operated through acoustic links while high speed data is transmitted using optical links.

In Table 13, we have provided some existing underwater hybrid systems discussed in literature.

5 Optical/optical wireless hybrid networks

The characteristics of different optical technologies vary from each other. LiFi and VLC offer high data rates and these systems are less affected by interference as compared to low data rate OCC systems. According to the transmission spectrum, OWC can be categorized into UV, VL and infrared. The VL spectrum is extensively used in FSO, LiFi, OCC and VLC communications. In some cases, VL spectrum is also utilized for FSO. FSO systems operate in NIR spectrum which is widely utilized by LiDAR, LiFi and OCC. A notable attention has been seen in UV spectrum due to its capability of NLOS optical communication links. UV communication is used to achieve high speed LOS and NLOS communications. FSO and LiFi also use UV spectrum. A comparison of UV, VL and IR for OWC systems is provided in Table 14. Moreover, these optical wireless technologies integrate different transceivers in hardware architecture. Such as LED is used due to high speed data transmission capacity of transmitters in OWC/OCC and VLC systems. On the receiving side, photodiodes are used in VLC and LiFi system to receive modulated light, whereas cameras are used in OWC/OCC system to receive optical pulses. The interference components can be spatially separated from the image sensor in OCC. As a result, BER and SINR are enhanced in OCC. However, most commercially available cameras limit the overall data rate due to limited frame rate of these cameras. Therefore, OCC seems promising in such application scenarios where attaining high BER and SINR is more essential than high data rates.

Recently, optical/optical hybrid wireless networks have become hot research topics among researchers. Hybrid optical/optical wireless networks incorporate two or more optical wireless technologies, which can enhance the system's performance in terms of energy efficiency, reliability, bit error rate (BER), data rate and throughput etc. enabling the combined benefits of both technologies. These hybrid networks can be implemented in various applications such as high speed wireless connectivity, load balancing, vehicular

Table 13 Some existing underwater hybrid systems in literature

References	Hybrid system	Research contribution
Moriconi et al. (2015)	Acoustic/optical	This study presents a hybrid acoustic-optic communication system for underwater swarms
Persia et al. (2016)	Acoustic/optical	This article provides useful analysis for the real-time implementation of an underwater swarm based on hybrid acoustic/optical communication system
Wang et al. 2017c)	Optical/acoustic	This article presents a promising solution for real-time video and image transmission for marine exploration and it provides a new technique for high-speed transfer of marine information detection
Saeed et al. (2018)	Acoustic/optical	Authors have proposed a novel localization technique based on hybrid acoustic/optical system for energy harvesting
Han et al. 2019)	Optical/acoustic	Authors have demonstrated real-time video streaming without optical cable by using a hybrid optical-acoustic network
Zhang et al. (2020b)	Acoustic/optical	This study addresses localization and tracking of a mobile ship with an AUV. Authors have used a hybrid acoustic/optical system to obtain high data rate, accurate localization and tracking
Cox et al. (2020)	Acoustic/RF	Authors have presented a hybrid system which can be implemented in low-power and accurate indoor positioning and IoT
Islam et al. (2021)	Acoustic/optical	In this recent study, authors have proposed a hybrid acoustic/optical underwater wireless communication model which reduces network power consumption and supports high-data rate underwater applications by considering suitable communication links in response to dynamic weather conditions and varying traffic loads. Authors have derived analytical modeling for both optics and acoustics, and calculated the transmission power requirements for reliable communication in different underwater environments.

Table 14 Comparison of UV, VL and IR systems

Characteristics	UV	VL	IR
Wavelength	10–400 nm	380–780 nm	780 nm–1 mm
Illumination	No	Communication with and without illumination	No
Communication technologies	FSO, LiFi	LiDAR, FSO, OCC, LiFi, VLC	LiDAR, FSO, OCC, LiFi
Transmission range	FSO: ultra-short to ultra-long LiFi: short and medium	LiDAR: short to ultra-long FSO: ultra-short to ultra-long CC, LiFi and VLC: short and medium range	LiDAR: short to ultra-long FSO: ultra-short to ultra-long OCC and LiFi: short and medium
Limitations	Human safety concerns	Ambient noise, unnecessary illumination,	Human safety, limited data rate
Advantages	High data rate NLOS	Safe, lightening	No visibility is cases where illumination is not required

communication and seamless movement. Hybrid optical/optical wireless systems are offer enhanced QoS level and improved link reliability. Hybrid VLC/OCC and LiFi/OCC can be used for indoor applications. For V2X communications, FSO/OCC, VLC/OCC and LiFi/OCC are possible hybrid systems. OCC offers a stable link for long distance communication in V2X communications. FSO/OCC provides long distance V2X communication while removing individual limitations and maintaining stable link performance. FSO can provide long distances and good performance in V2X communications. However, FSO requires precise pointing and it is severely affected by outdoor atmospheric conditions. While OCC offers comparatively short distance communication with low data rates. As cameras are used in comfort and safety application. Hence, OCC offers safety assistance solutions based on the communication. Therefore, the hybrid approach of these two technologies can increase reliability and satisfy user demand as well. However, its performance suffers from atmospheric conditions in outdoor scenarios specifically precise control of the transceiver (Vats et al. 2019). The high mobility requirement is also critical for V2X communication. To address coverage area, bit error requirement, handling of diverse data rates, interference effect, pointing navigation and precise indoor and outdoor localization, a hybrid FSO/VLC system is proposed in literature (Pesek et al. 2018; Huang 2017). The implementation and deployment of FSO/VLC heterogeneous interconnection together with traffic management, routing algorithm, localization, mobility support and handover issues are briefly discussed in Huang (2017). Figure 15 represents hybrid optical scenarios for VLC/OCC and FSO/VLC wireless systems. The first diagram (left to right) shows a hybrid VLC/OCC system which can communicate using both image sensor and PDs with the same LED. In this system, low speed OCC and high speed VLC signals are transmitted in a combined form. Therefore, this hybrid network offers diverse services with low complexity of lighting system at low cost as all LEDs are equipped with same type of driving circuits and modems sharing the same network. Moreover, electric energy consumption is also low as the total number of LEDs for communication is reduced. The second diagram (left to right) shows a hybrid FSO/VLC system. This system has a potential to provide alternative solution to overcome the bandwidth issue in the last mile and last meter access scenarios. In such hybrid systems, a high speed FSO link is used to realize inter-building connectivity, which can easily occupy a number of access points in indoor scenarios. The received FSO signal is then transmitted through single mode fibers (SMFs) within rooms and VLC technology is further used to enable last meter connectivity for the end users. However, several challenging issues are also envisaged in these hybrid systems.

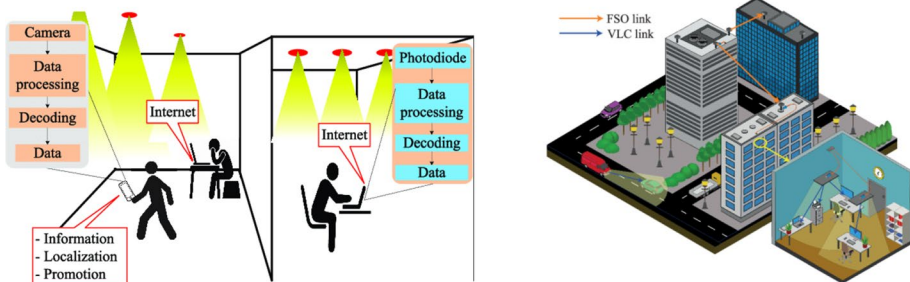

Fig. 15 Scenarios of hybrid VLC/OCC (Nguyen et al. 2019) and FSO/VLC (Pesek et al. 2018) (left to right)

Table 15 Some existing research studies on hybrid optical/optical systems

References	Hybrid type	Research contribution
Huang (2017)	FSO/VLC	This study presents a hybrid FSO/VLC wireless system for future space-air-ground-ocean-integrated communications. Authors have briefly discussed functional modules and deployment details of hybrid FSO/VLC networks. The basic mechanisms are defined including user identification and localization, user mobility and handoff control, and routing and traffic management
Hasan et al. (2018a)	OCC/LiFi	This article proposes a hybrid OCC/LiFi system to enhance QoS for users. In this work, a network assignment mechanism and dynamic link switching for efficient handover management is proposed. The performance analysis of this work validate the feasibility of proposed hybrid mechanism. A time division multiple access (TDMA) based technique round robin scheduling (RRS), is used to enable fairness in time resource allocation to serve multiple users within the hybrid system with same LED
Pesek et al. (2018)	FSO/VLC	It presents an experimental demonstration of hybrid system to overcome bandwidth bottleneck in the last mile and last meter access networks
Hasan et al. (2018c)	OCC/LiFi	This study highlights analysis of hybrid FSO/VLC link, link strength and atmospheric turbulence effect
Bao et al. (2017)	VLC/OCC	This study proposes a hybrid OCC/LiFi system. It uses fuzzy logic method to find the best network using same LED for both OCC and LiFi systems. Authors have provided comprehensive details about performance of selection mechanism
You et al. (2018)	Hybrid VL/IR	In this paper, a hybrid scheme is proposed which allows PD and camera to simultaneously receive the light signal on the same transmitter. Camera receives low frequency signal while high frequency signal is received by PD. Authors have investigated some techniques to improve data rate for the system using PD
Nguyen et al. (2019)	VLC/OCC	In this article, authors have proposed a hybrid VL/IR transmission scheme for indoor VLC systems based on multi-pulse position modulation (MPPM) and orthogonal frequency division multiplexing (OFDM). A low-power IR link is used to establish VL transmission. This proposed scheme is power-efficient to meet the sensitivity requirement of the receiver. This scheme can extend dimming control while attaining reliable and stable transmission quality
		This study proposes a hybrid VLC/OCC system for versatile indoor applications. OCC receives low frequency signals while high frequency signals are received by VLC
		It reduced deployment cost for indoor optical wireless systems and facilitates users to obtain data regardless of their device. To utilize the dimming property of LED, Manchester coding is used for VLC while variable pulse position modulation scheme is used for OCC. Authors have measures transmission distance of more than 4 m for both services

Table 15 (continued)

References	Hybrid type	Research contribution
Vats et al. (2019)	VLC/FSO/VLC	In this study, authors have proposed a three hop hybrid VLC/FSO/VLC system. The performance of the proposed system is derived in terms of the close-form expression for the outage probability. The error performance is analyzed in terms of average symbol error probability. In addition, asymptotic outage probability expression is derived to find the behavior of the system at high SNR regimes. Numerical plots are provided to check the impact of variation in the parameters on the hybrid VLC/FSO/VLC system
Hasan et al. (2019b)	OCC/LiFi	In this study, authors have developed a hybrid encoding scheme for hybrid OCC/LiFi system. A single multilevel LED is used to transmit both OCC and LiFi data streams using intensity-shift keying. First data stream is transmitted at high frequency. A camera is used to detect the consecutive data streams. Authors have designed a prototype to validate proposed concept
Pham et al. (2019)	Hybrid OCC waveforms	This study proposes a novel error correction technique based on neural network and artificial intelligence. This technique can add region-of-interest (RoI) signaling functionality for cars using headlight or taillight with a hybrid systems of hybrid of a low-rate and high-rate waveforms. Both waveforms can transfer two data streams with a single LED array in transmitter. On receiver side, a single camera is used for light source identification and demodulation
Thieu et al. (2019)	Hybrid waveform for OWC/OCC	In this paper, authors have introduced a new hybrid waveform for OWC/OCC systems. In vehicular communication which requires long distance, high mobility and high speed communication, deploying a hybrid waveform reduces the cost and ensures high speed data transmission. Authors have introduced region-of-interest (RoI)-signaling technique which enables OWC/OCC systems to transmit low-rate and high-rate data streams respectively. The purpose of low data rate stream is to detect the RoI to establish communication link while high rate data stream is used for data transmission
Lee et al. (2020)	FSO/VLC	This study proposes a low cost, portable hybrid RF/VLC and FSO system for multimedia broadcasting and indoor wireless communications. It presents wireless and economical approach for real-time audio and video streaming. Proposed idea gives 1 kbps data rate at 4 cm transmission distance
Ali, et al. (2020)	FSO/VLC	In this paper, authors have proposed a low cost, flexible and fully passive integration of FSO and VLC techniques which can be used for last mile access network and solid-state lighting. Authors used non-return-to-zero on-off keying (NRZ-OOK) modulation scheme to achieve 1.4Gbps data rate over an optical link based on 7 m FSO, 2 m plastic optical fiber and 30-cm VLC

- As modulation bandwidth for both technologies is different, so different LEDs are used to transmit data streams.
- To identify the correct LED to communicate for a particular application will be challenging.
- Same LED can be utilized for the hybrid system with multiple access techniques. However, the implementation complexity of the network assignment will be increased.
- Using different LEDs for OCC and LiFi will also increase the overall cost.

In hybrid FSO/VLC systems, FSO link operates for backhaul connectivity while VLC link is used to connect users. Such hybrid systems increase link reliability as well as full user's requirement. The convergence of two systems improves services with low interference effect in LiFi/VLC. Several constraints e.g. traffic type, communication distance, precise pointing and data rate requirements must be kept into account for any suitable link selection in hybrid optical/optical wireless systems. Table 15 presents some existing research studies on hybrid optical/optical systems.

6 Challenges and open research issues

Some important challenging issues for efficient deployment of hybrid optical wireless systems are briefly discussed below.

6.1 Energy harvesting with dual-hop hybrid wireless system

Simulation analysis of a dual hop system containing RF and VLC links are provided in some studies. Whereas energy harvesting concept along with data transfer is a new idea which appears to be a power-efficient solution. Energy harvesting drawbacks where delay appears have to be reduced. Several studies have optimized targeting single constraint such as system secrecy, maximum user data rate and overall system delay. Researchers should focus on investigating multiple constraints to analyze harvested power and data packet loss. In addition, a suitable handover mechanism should be introduced which can improve system reliability. Finally, hardware prototype design, optimal design of hybrid system and real-time implementation can be a possible future direction.

6.2 Resource allocations and AP selection in RF/VLC networks

Several studies have focused on AP selection in RF/VLC networks. Either a hybrid system contains a central control unit or not, the algorithms will vary. The key objective is to find an energy efficient algorithm which enable fairness of the hybrid network over RF and VLC networks and enhances the throughput of network users. Machine learning based algorithms can be a possible solution for non-convex optimization problem. In addition, future research should focus on finding low-cost and efficient optimization algorithm with best network throughput and reduced power transmission, delay and control overhead. The metrics considered for comparison of different algorithms are outage probability, user satisfaction and network fairness. Moreover, resource allocation like the number of APs, power and bandwidth allocations are also critical issues in network design. In Liu et al. (2020), proposed optimal power allocation algorithm for hybrid VLC and power line. Authors have

designed power allocation strategy based on NOMA. Multiple users can access frequency and time resources by utilizing non-orthogonal multiple access (NOMA).

6.3 Design and implementation of practical hybrid RF/VLC network (testbeds)

The most important step to propose a new algorithm is to test it for real-time implementation on hardware. Therefore, development and implementation of testbed for hybrid networks is crucial to develop any solid comparison between resource allocation algorithm and proposed handover. These practical implementations are different in number of users and cost. In future, further optimization schemes for existing testbeds will be required to ensure flexibility to the researchers in terms of best network design and real-time applications. In future, low cost testbeds will open horizons of research interest in hybrid networks and optimization methods. In practical deployments of hybrid RF/VLC networks, standalone VLC can be augmented to enhance the data rate coverage. While RF access points can be used to improve the overall rate performance of heterogeneous networks and enable ubiquitous control functionalities. It will develop significant research interest from researchers to design new uses cases and applications for hybrid networks.

6.4 Network selection

It is evident from the current research that effective network selection is crucially important in hybrid systems. Different hybrid networks are designed to be used in different scenarios to make best use of their flexibilities and capabilities. While a hybrid network enhances system performance, it also challenges the techniques of access network selection due to integration of heterogeneous networks. This problem in heterogeneous network is more complicated than a homogeneous network of a straightforward network selection technique. There are several factors which make network selection challenging. The optimal network selection changes according to the heterogeneous technologies and environment. Fine-grained network selection techniques are needed to enable high user QoE. Network selection depends on different heterogeneous parameters such as communication distance, traffic type, precise pointing and required data rate. An efficient network selection must ensure high data rate, low latency and high user QoE. The network selection criteria differs for existing RF technologies as well as differ considerably differs for various OWC technologies. Several research studies have addressed these parameters, but real-time successful implementation of hybrid systems in a dynamic and unknown environment is still

Table 16 Network sharing in different hybrid systems in literature

References	Hybrid system	Uplink	Downlink
Pan et al. (2017)	RF/VLC	RF	VLC
Ayyash (2016)	WiFi/LiFi	WiFi	LiFi
Shao, et al. (2014), Hu et al. (2016)	VLC/WiFi	WiFi	VLC
Gulbahar and Sencan (2017)	RF/OCC	RF	RF and OCC
Wang et al. (2017b)	LiFi RF	No difference for both up and down links	
Al-Khori et al. (2019)	RF/VLC	Downlink hybrid RF/VLC	
Shao (2015)	VLC/WiFi	Uplink VLC and WiFi	

a challenging task. Intelligent adaptation of these parameters as well as efficient selection technique is essential to harness the advantages of hybrid networks. However, depending on environment or application, either indoor or outdoor, the network parameters must be optimized to fully use the advantages of hybrid networks. Similarly, computation time must be taken into account in order to reduce the delay. In Hasan et al. (2018c), a network selection method based on fuzzy logic is presented for hybrid OCC/LiFi communication. In this proposed method, an access point is selected for different application scenarios by using fuzzy logic. The proposed mechanism ensures proper utilization of network resources as well as enhances the QoS. Moreover, we expect more researchers will focus on testbeds and furthers new applications will merge for hybrid networks. It means new network topologies and algorithms will be introduced to adapt network according to applications and environmental conditions. Table 16 presents network sharing in different research works on hybrid networks. RF performs well for both uplink and downlink while VLC and LiFi cannot perform well for uplink communication.

6.5 Access Protocol

User mobility plays a key role in wireless communication systems. In case of mobile receiver, pointing, tracking and localizing the moving receiver are the key challenges (Bao et al. 2017). A suitable access protocol is required if multiple moving users share limited channel resources. The carrier sense multiple access with collision avoidance (CSMA/CA) protocol was introduced for single network scenario. In recent studies, researchers have proposed a hybrid access protocol which achieves high throughput and low collision probability along with a low average delay. This hybrid protocol includes CSMA/CA and TDMA. Hybrid access protocol can use resources more effectively. Researchers have been working to design medium access protocols for optical/optical and RF/optical hybrid networks.

6.6 Handover

Several studies have been reported on efficient vertical handover (VHO) scheme in RF communications. In RF/optical hybrid networks, the random mobility of users in optical channel involves complexity in VHO. The properties of data link and physical layers possess critical issues in mobility management of hybrid systems. Research fraternity should focus on investigating efficient handover decision algorithms for hybrid networks. It is also important to avoid unnecessary handover. As optical channel is blocked due to obstacles, it adds a unique factor to target the network during handover. The handover duration must be short. Handover duration depends on algorithms used and transmission losses in hybrid systems. It is worth noting, the small coverage area of VLC and LiFi enables several handovers in indoor applications. In Wang and Haas (2015), Wang et al. have presented handover concept in hybrid LiFi/WiFi system. In such hybrid system, user mobility and intermittent light-path blockages introduce frequent handovers resulting a low system throughput. Several mechanisms have been reported in literature to mitigate the handover issue in hybrid LiFi/WiFi networks. In Saud and Katz (2017), authors have proposed a novel implementation of fast handover in hybrid optical/RF wireless networks. The proposed mechanism can efficiently monitor VLC link and then quickly switches to RF link as VLC link drops. In a

recent study Wu et al. (2020b), authors used a reinforcement learning-based approach for optimal vertical handover with QoS guarantee.

6.7 Load balancing

Current research studies validate that hybrid RF/VLC network provides better performance in terms of user mobility and bandwidth. However, it is much needed to perform an efficient load balancing scheme to ensure network reliability regardless of locations and times. To develop a scalable load-balancing method with low handover overhead is a challenging issue. Researchers have been investigating different load balancing schemes to enhance network throughput as location aware and mobility aware algorithms. In hybrid networks, an effective dynamic load balancing scheme is required. Any possible scheme should consider parameter like outage probability, network fairness, control overhead and maximum data rate. Load balancing or resource allocation problem can be reduced by finding optimal user association. In a mobile scenario, users can switch to different serving APs and a possible handover can be prompted. Effective load balancing can improve link reliability and network availability. Wang et al. (2017b) presented load balancing game for indoor hybrid RF/LiFi systems. They also presented dynamic load balancing for better performance of hybrid LiFi/WiFi networks (Wang and Haas 2015). In this scheme, moving users are served by WiFi while quasi-static users are served by LiFi. In Li et al. (2016a), researchers have proposed a mobility-aware load balancing method for hybrid visible light communication-long term evolution (VLC-LTE) networks. It operates by learning the moving trajectories of indoor users and leveraging the location-sensitive characteristics of VLC communication.

6.8 Cross-layer design

Secrecy is an important feature, which is highly considered by users and multiple applications. Several research studies have highlighted security issue in network in order to find network's sustainability to potential malicious attacks. An important feature which impacts on network's security is the location of the eavesdropper. More research is required to minimize power consumption in network while ensuring security in different conditions.

The inherent broadcast feature of VLC can cause eavesdropping by malicious terminals in the coverage area of VLC transmitter as light signals are transmitted without any waveguide or optical fibers. Then, physical layer security (PLS) emerged as a promising solution to prevent eavesdropping and mitigate jamming attacks (Li et al. 2014; Pan et al. 2015). Several studies have investigated different methods to enhance the secrecy performance of VLC systems (Mostafa and Lampe 2015; Pan et al. 2016). These studies can provide a roadmap to develop a mechanism for enhancing the secrecy performance of hybrid RF/optical systems. Existing hybrid RF/optical systems focus on physical layer metrics. Upper layers security methods such as cryptography and data encryption can be utilized but they require high computational and processing power consumption. In Al-Khori et al. (2019) proposed physical layer security algorithms based on zero-forcing beamforming techniques to overcome eavesdropping in hybrid RF/VLC system. Hybrid system rarely address data link layer. Due to drastic increase in network traffic and high data rate services, we must consider QoS metrics of data link layer as well as physical layer. The cross layer performance analysis between data link and physical layers are crucially important. Several studies related to cross-layer analysis have addressed RF scenarios while only a few studies have focused on OWC systems. Researchers should pay significant attention to cross-layer

performance investigations. In Rakia et al. (2017), authors have made cross-layer analysis for point-to-multipoint (P2MP) hybrid FSO/RF networks. Authors have shown that P2MP hybrid FSO/RF network shows better performance as compared to P2MP FSO-only network.

6.9 Modulation techniques in wireless hybrid systems

The modulation schemes for OCC are different from VLC and LiFi. OCC cannot support high modulation schemes due to limited frame capacity of cameras. The implementation of modulation schemes in hybrid optical/optical wireless systems is a challenging issue. Although OCC and VLC use LEDs as transmitter, it is yet difficult to find any literature to integrate these technologies in a single module. OCC and VLC are LOS-based technologies. Users should find suitable lamps when OCC and VLC are serviced from different LEDs. When both technologies integrate, however, users can get services from same LED regardless of their devices and applications. Another major concern in integration of both technologies is operating frequencies. Image sensors cannot fully recognize higher frequencies as compared to PDs because of slow response time (Do and Yoo 2016). Whereas, VLC is integrated with PLC to communicate with PDs (Ding 2015). On the other hand, OCC needs another LED due to its lower frequencies. In addition, OCC and VLC cause interference as both are same visible light. It brings noise at other's receiving component. In Nguyen et al. (2019), authors have demonstrated hybrid VLC/OCC system. They have used Variable Pulse Position Modulation (VPPM) for OCC and Manchester coding for VLC to remove aforementioned issues. In addition, authors in Wu et al. (2017) implemented a novel hybrid of radio optical OFDM (HROOFDM) scheme by combining VLC and RF links in the physical layer. This new modulation scheme improves power and bandwidth allocation as well as optimization. Several studies have focused on non-orthogonal multiple access (NOMA) which is less sensitive to LOS availability (Al Hammadi et al. 2019). In NOMA, users share available frequency and time resources which leads to better spectral efficiency and low latency (Ding et al. 2017). In future, it is envisaged that research community will focus on improving access methods and modulation scheme by hybrid networks in order to optimize the resources and enhance the performance.

6.10 Performance enhancements in mixed RF/FSO relay systems

The system capacity is very sensitive to pointing error and atmospheric turbulence as it can significantly degrade end-to-end performance of hybrid RF/FSO system. It is observed that interferer's power can highly affect the performance. The outage performance deteriorates as weather becomes harsher because the scattering loss increases. This limitation can be overcome by additional transmission power. However, high transmission power can lead to low secrecy performance. Consequently, an efficient power allocation technique for hybrid RF/FSO is necessary. In Al-Eryani et al. (2018), authors have carried out performance analysis and power allocation for hybrid RF/FSO system. Authors have addressed the impacts of several parameters including outage probability threshold, atmospheric turbulence conditions, pointing error and number of users. It is shown that in small pointing error and weak turbulence, the outage probability is dominated by RF downlink/uplink. However, in severe pointing error, it is dominated by FSO downlink/uplink.

6.11 Atmospheric effects on hybrid FSO/RF networks

FSO has notable prime advantages among various OWC technologies when a high data rate link is needed ground-space applications. However, this technology severely suffers from reliability and availability challenges due to adverse weather conditions. Atmospheric attenuation caused by scattering and absorption is a main challenge in short range outdoor OWC. Clouds, snow, rain, fog cause scattering while carbon dioxide and water particles cause absorption in optical transmission in free space. Among these, fog is the most deterrent factor which highly affects the availability of FSO. A hybrid network can be a viable solution to overcome attenuation. An adjunct directional RF link can be used to facilitate backup connectivity. The appropriate frequency selection in hybrid RF/FSO system necessitates the study of different link attenuators which can ensure high availability under different atmospheric conditions. Higher frequencies cause high attenuation in foggy conditions. Thus, low frequencies are used to achieve high availability though at low data rates. Nadeem et al. (2009) studied weather effects on hybrid FSO/RF and found that convergence of FSO with 40 GHz RF gives promising results in foggy conditions. Employing FSO link with a GHz frequency range backup link provides comparable data rates and high availability. Low GHz frequencies in industrial, scientific and medical (ISM) band as backup link can also ensure high availability. Thus, there exists a tradeoff in adapting a suitable frequency for the backup link dependent upon specific weather conditions. Cost and data rate requirements will also play a vital role in selecting backup link frequency. Moreover, knowing atmospheric obscuration, traffic demand, topology configuration and developing adaptive algorithms can also ensure availability and optimal network performance. Future studies should focus on finding appropriate parameters of different weather conditions and locations for FSO/RF hybrid networks. Table 17 presents atmospheric effects on different communication technologies.

6.12 IRS-assisted hybrid networks

Intelligent reflecting surface (IRS) is an emerging technology which enables various appealing functions in wireless channel reconfiguration, such as nulling/suppressing inter-channel/co-channel interference, refining the channel distributions/statistics, adding extra signal paths and creating virtual line-of-sight (LOS) path to bypass obstacles between transmitter and receiver through smart reflections. IRS offers various practical advantages such as IRS passive reflecting elements can reflect the impinging signals without the need of any transmit power, thus offers low energy and hardware cost as compared to active surfaces (Wu et al. 2021b). Besides, IRS has a conformal geometry, light weight and low profile, which makes it effectively suitable for integration in a desired environment or object. Furthermore, it operates in full-duplex (FD) mode and has freedom from self-interference and antenna noise amplification. IRS is an auxiliary device in wireless communication and enables transparent integration, thus offering high compatibility and flexibility with current wireless communication

Table 17 Availability of FSO with 40 GHz RF (Nadeem et al. 2009)

Weather condition	FSO (%)	40 GHz (%)	Hybrid (%)
Snow	39.49	100	100
Rain	85.71	14.29	85.71
Dense maritime fog	0.51	100	100

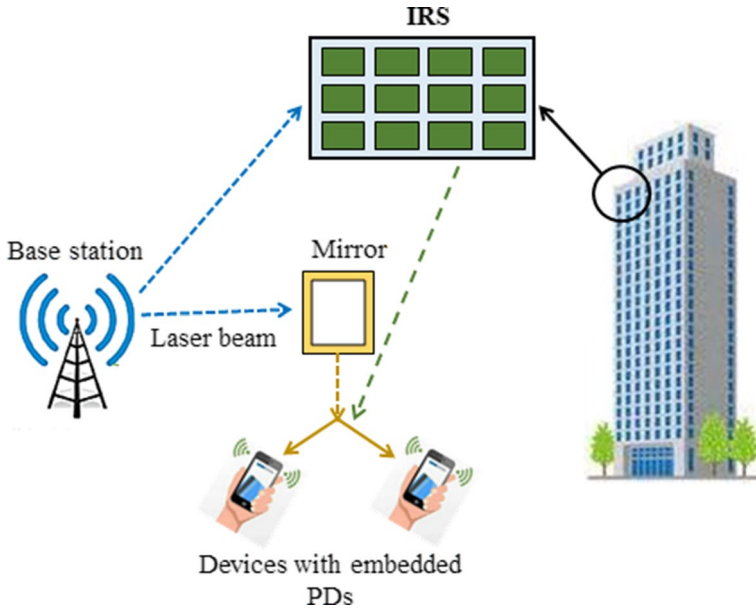

Fig. 16 IRS-assisted RF/VLC hybrid system

systems such as LiFi and WiFi. Due to these potential features, IRS is appropriate for colossal deployment in wireless networks for cost-efficient improvement in its energy and spectral efficiencies. Improved energy efficiency, low complexity and full-band response of IRS makes it ideally suitable at any operating frequency.

IRS-assisted RF/VLC hybrid network can be deployed in outdoor scenarios as shown in Fig. 16. In this outdoor scenario, mirror is used to reflect visible light towards a photodetector while IRS is used to reflect radio frequency signals from the base station (Alghamdi et al. 2020). IRS can be used to complement VLC in scenarios where LoS link is obstructed. Deploying IRS-assisted VLC systems can support secure and reliable communication which compensates the potential failure of any connection links.

Similarly, hybrid LiFi/RF systems offer enhanced security and privacy, LoS blockage mitigation and RF traffic offloading by using both optical and RF spectra (Ayyash 2016). The close integration of IRS-assisted LiFi and IRS-assisted RF is recognized as a natural continuum to hybrid LiFi/RF systems. This coexistence will enable significant synergies including potentials to meet the stringent requirements of future 6G networks. However, distinctive challenges also arise in this integration which require significant research contributions on cross-band selection, cross-layer analytical tools, energy management schemes, reliable resource allocation and complex load balancing approaches.

7 Conclusion

Recently, research in OWC technologies is rapidly growing as traditional RF technologies cannot fulfil drastic demands of 5G/6G wireless systems. OWC has become an emerging alternative to RF technology due to its excellent features of high data rate, license-free spectrum and long distance communication. The convergence of two technologies such as

RF and OWC can overcome the limitations of each technology. Therefore, the hybrid networks such as RF/optical or optical/optical can mitigate the drawbacks of either RF or optical wireless system. These hybrid networks offer high performance and flexibility. Studies on remaining aspects related to network selection, application scenarios, data rate requirement etc. are underway. This review paper addresses various optical and RF technologies, hybrid RF/optical, hybrid optical/optical, hybrid acoustic/optical, hybrid acoustic/RF wireless networks, applications, potential challenges and open research issues. In this study, we have provided a summary of different configurations of hybrid systems including optical based FSO, VLC, OCC and LiFi as well as RF-based BLE, WiFi, small cells and macro-cells are considered. We have also discussed several challenging issues such as network selection, atmospheric effects, handover, load-balancing, modulation techniques, cross-layer design, access protocol, resource allocation and IRS-assisted hybrid networks. An extensive range of applications such as indoor, vehicular communication, eHealth, backhaul connectivity solution and underwater communication is considered. In addition, we have addressed open research issues for design and successful deployment of hybrid wireless networks. This study highlights previous research contributions addressing aforementioned aspects in RF/optical, optical/optical, acoustic/RF and acoustic/optical hybrid wireless systems. This review paper will provide sufficient guidance for future researchers to understand previous studies and future research directions in hybrid wireless networks.

References

- Abouzohri, E.M.H., Abdallah, M.M.: Performance of hybrid cognitive RF/VLC systems in vehicle-to-vehicle communications. In: 2020 IEEE International Conference on Informatics, IoT, and Enabling Technologies (ICIOT), pp. 429–434 (2020)
- Abrahamson, M.J., Oaida, B.V., Sindi, O., Biswas, A.: Achieving operational two-way laser acquisition for OPALS payload on the International Space Station. In: Free-Space Laser Communication and Atmospheric Propagation XXVII, **9354**, 935408 (2015)
- Abuella, H., et al.: Hybrid RF/VLC systems: a comprehensive survey on network topologies, performance analyses, applications, and future directions. *arXiv Prepr. arXiv:2007.02466* (2020)
- Ai, Y., Mathur, A., Lei, H., Cheffena, M., Ansari, I.S.: Secrecy enhancement of RF backhaul system with parallel FSO communication link. *Opt. Commun.* **475**, 126193 (2020)
- Al Hammadi, A., Muhaidat, S., Sofotasios, P.C., Al Qutayri, M.: A robust and energy efficient NOMA-enabled hybrid VLC/RF wireless network. In: 2019 IEEE Wireless Communications and Networking Conference (WCNC), pp. 1–6 (2019)
- Alao, O.D., Joshua, J.V., Franklyn, A.S., Komolafe, O.: Light fidelity (Li-Fi): an emerging technology for the future. *IOSR J. Mob. Comput. Appl.* **3**(3), 18–28 (2016)
- Albraheem, L.I., Alhudaithy, L.H., Aljaser, A.A., Aldhafian, M.R., Bahliwah, G.M.: Toward designing a Li-Fi-based hierarchical IoT architecture. *IEEE Access* **6**, 40811–40825 (2018)
- Aldalbahi, A., Rahaim, M., Khreishah, A., Ayyash, M., Little, T.D.C.: Visible light communication module: An open source extension to the ns3 network simulator with real system validation. *IEEE Access* **5**, 22144–22158 (2017)
- Al-Eryani, Y.F., Salhab, A.M., Zummo, S.A., Alouini, M.-S.: Two-way multiuser mixed RF/FSO relaying: performance analysis and power allocation. *J. Opt. Commun. Netw.* **10**(4), 396–408 (2018)
- Alghamdi, R., et al.: Intelligent surfaces for 6G wireless networks: a survey of optimization and performance analysis techniques. *IEEE Access* (2020)
- Ali, A., et al.: A novel integrated fully passive optical network for free-space optics and visible light communication for last-mile access network based on composite phosphor film. In: International Conference on Optoelectronic and Microelectronic Technology and Application, **11617**, 1161719 (2020)
- Alimi, I., Shahpari, A., Sousa, A., Ferreira, R., Monteiro, P., Teixeira, A.: Challenges and opportunities of optical wireless communication technologies. *Opt. Commun. Technol.* **10** (2017)

- Al-Khori, J., Nauryzbayev, G., Abdallah, M.M., Hamdi, M.: Secrecy performance of decode-and-forward based hybrid RF/VLC relaying systems. *IEEE Access* **7**, 10844–10856 (2019)
- Al-Kinani, A., Wang, C.X., Zhou, L., Zhang, W.: Optical wireless communication channel measurements and models. *IEEE Commun. Surv. Tutor.* **20**(3), 1939–1962 (2018). <https://doi.org/10.1109/COMST.2018.2838096>
- Alsulami, O.Z., Saeed, S.O.M., Mohamed, S.H., El-Gorashi, T.E.H., Alresheedi, M.T., Elmoghani, J.M.H.: Resource allocation in co-existing optical wireless HetNets. In: 2020 22nd International Conference on Transparent Optical Networks (ICTON), pp. 1–7 (2020)
- An, J., Pham, N.Q., Chung, W.-Y.: Multiple bio-monitoring system using visible light for electromagnetic-wave free indoor healthcare. *Opt. Commun.* **405**, 107–113 (2017)
- Anbalagan, R., Hussain, M.Z., Jayabalakrishnan, D., Muruga, D.B.N., Prabhakar, M.: Vehicle to vehicle data transfer and communication using Li-Fi technology. *Mater. Today Proc.* **45**, 5925–5933 (2021)
- Anbarasi, K., Hemanth, C., Sangeetha, R.G.: A review on channel models in free space optical communication systems. *Opt. Laser Technol.* **97**, 161–171 (2017)
- Andrews, J.G., Claussen, H., Dohler, M., Rangan, S., Reed, M.C.: Femtocells: past, present, and future. *IEEE J. Sel. Areas Commun.* **30**(3), 497–508 (2012)
- Arfaoui, M.A., et al.: Physical layer security for visible light communication systems: a survey. *IEEE Commun. Surv. Tutor.* **22**(3), 1887–1908 (2020)
- Arnon, S.: Underwater optical wireless communication network. *Opt. Eng.* **49**(1), 015001 (2010). <https://doi.org/10.1117/1.3280288>
- Arnon, S., Barry, J., Karagiannidis, G., Schober, R., Uysal, M.: *Advanced optical wireless communication systems*. Cambridge University Press, Cambridge (2012)
- Arya, S., Chung, Y.H.: Novel indoor ultraviolet wireless communication: design implementation, channel modeling, and challenges. *IEEE Syst. J.* **15**(2), 2349–2360 (2020)
- Ayyash, M., et al.: Coexistence of WiFi and LiFi toward 5G: concepts, opportunities, and challenges. *IEEE Commun. Mag.* **54**(2), 64–71 (2016)
- Baig, S., Asif, H.M., Umer, T., Mumtaz, S., Shafiq, M., Choi, J.-G.: High data rate discrete wavelet transform-based PLC-VLC design for 5G communication systems. *IEEE Access* **6**, 52490–52499 (2018)
- Bao, X., Yu, G., Dai, J., Zhu, X.: Li-Fi: light fidelity—a survey. *Wirel. Netw.* **21**(6), 1879–1889 (2015)
- Bao, X., Dai, J., Zhu, X.: Visible light communications heterogeneous network (VLC-HetNet): new model and protocols for mobile scenario. *Wirel. Networks* **23**(1), 299–309 (2017)
- Basnayaka, D.A., Haas, H.: Design and analysis of a hybrid radio frequency and visible light communication system. *IEEE Trans. Commun.* **65**(10), 4334–4347 (2017)
- Bazzi, A., Masini, B.M., Zanella, A., Calisti, A.: Visible light communications as a complementary technology for the internet of vehicles. *Comput. Commun.* **93**, 39–51 (2016)
- Blinowski, G.: Security of visible light communication systems—a survey. *Phys. Commun.* **34**, 246–260 (2019)
- Boucouvalas, A.C., et al.: Standards for indoor optical wireless communications. *IEEE Commun. Mag.* **53**(3), 24–31 (2015)
- Boulogeorgos, A.-A.A., Sofotasios, P.C., Muhaidat, S., Valkama, M., Karagiannidis, G.K.: The effects of RF impairments in vehicle-to-vehicle communications. In: 2015 IEEE 26th Annual International Symposium on Personal, Indoor, and Mobile Radio Communications (PIMRC), pp. 840–845 (2015)
- Brugarolas, R., et al.: Wearable heart rate sensor systems for wireless canine health monitoring. *IEEE Sens. J.* **16**(10), 3454–3464 (2015)
- Cahyadi, W.A., Kim, Y.H., Chung, Y.H., Ahn, C.-J.: Mobile phone camera-based indoor visible light communications with rotation compensation. *IEEE Photonics J.* **8**(2), 1–8 (2016)
- Cahyadi, W.A., Chung, Y.H., Ghassemlooy, Z., Hassan, N.B.: Optical camera communications: principles, modulations, potential and challenges. *Electronics* **9**(9), 1339 (2020)
- Căilean, A.-M., Dimian, M.: Current challenges for visible light communications usage in vehicle applications: a survey. *IEEE Commun. Surv. Tutor.* **19**(4), 2681–2703 (2017)
- Chakraborty, A., Dutta, T., Mondal, S., Nath, A.: Latest advancement in Light Fidelity (Li-Fi) technology. *Int. J. Adv. Res. Comput. Sci. Manag. Stud.* **5**(12), 47–53 (2017)
- Chang, K.-H.: Bluetooth: a viable solution for IoT? [Industry Perspectives]. *IEEE Wirel. Commun.* **21**(6), 6–7 (2014)
- Charles, J.R., Hoppe, D.J., Sehic, A.: Hybrid RF/optical communication terminal with spherical primary optics for optical reception. *Int. Conf. Space Opt. Syst. Appl. (ICSOS)* **2011**, 171–179 (2011)
- Chaudhary, S., Amphawan, A.: The role and challenges of free-space optical systems. *J. Opt. Commun.* **35**(4), 327–334 (2014)
- Chavez-Burbano, P., et al.: Optical camera communication system for Internet of Things based on organic light emitting diodes. *Electron. Lett.* **55**(6), 334–336 (2019)

- Chen, H.-W., et al.: Color-shift keying for optical camera communication using a rolling shutter mode. *IEEE Photonics J.* **11**(2), 1–8 (2019)
- Chen, J., You, X.: Visible light positioning and communication cooperative systems. In: 2017 16th International Conference on Optical Communications and Networks (ICOON), pp. 1–3 (2017)
- Cheng, H.T., Zhuang, W.: Bluetooth-enabled in-home patient monitoring system: early detection of Alzheimer's disease. *IEEE Wirel. Commun.* **17**(1), 74–79 (2010)
- Cheng, L., Viriyasitavat, W., Boban, M., Tsai, H.-M.: Comparison of radio frequency and visible light propagation channels for vehicular communications. *IEEE Access* **6**, 2634–2644 (2017)
- Chowdhury, M.Z., Hossan, M.T., Islam, A., Jang, Y.M.: A comparative survey of optical wireless technologies: Architectures and applications. *IEEE Access* **6**, 9819–9840 (2018)
- Chowdhury, M.Z., Shahjalal, M., Hasan, M., Jang, Y.M.: The role of optical wireless communication technologies in 5G/6G and IoT solutions: prospects, directions, and challenges. *Appl. Sci.* **9**(20), 4367 (2019a)
- Chowdhury, M.Z., Hossan, M.T., Hasan, M.K., Jang, Y.M.: Integrated RF/optical wireless networks for improving QoS in indoor and transportation applications. *Wirel. Pers. Commun.* **107**(3), 1401–1430 (2019b)
- Chowdhury, M.Z., Hasan, M.K., Shahjalal, M., Hossan, M.T., Jang, Y.M.: Optical wireless hybrid networks: Trends, opportunities, challenges, and research directions. *IEEE Commun. Surv. Tutor.* **22**(2), 930–966 (2020)
- Chun, H., et al.: LED based wavelength division multiplexed 10 Gb/s visible light communications. *J. Light. Technol.* **34**(13), 3047–3052 (2016)
- Collotta, M., Pau, G., Talty, T., Tonguz, O.K.: Bluetooth 5: a concrete step forward toward the IoT. *IEEE Commun. Mag.* **56**(7), 125–131 (2018)
- Cox, B., Van der Perre, L., Wielandt, S., Ottoy, G., De Strycker, L.: High precision hybrid RF and ultrasonic chirp-based ranging for low-power IoT nodes. *EURASIP J. Wirel. Commun. Netw.* **2020**(1), 1–24 (2020)
- Dahrouj, H., Douik, A., Rayal, F., Al-Naffouri, T.Y., Alouini, M.-S.: Cost-effective hybrid RF/FSO backhaul solution for next generation wireless systems. *IEEE Wirel. Commun.* **22**(5), 98–104 (2015)
- Deicke, F., Shwartz, J.: Li-Fi: a new paradigm in wireless communication. (2012). <https://www.electronicsforu.com/technology-trends/li-fi-new-paradigm-wireless-communication>
- Delga, A., Leviandier, L.: Free-space optical communications with quantum cascade lasers. In: Quantum Sensing and Nano Electronics and Photonics XVI, **10926**, 1092617
- Delgado-Rajo, F., Melian-Segura, A., Guerra, V., Perez-Jimenez, R., Sanchez-Rodriguez, D.: Hybrid RF/VLC network architecture for the internet of things. *Sensors* **20**(2), 478 (2020)
- Diamant, R., Lampe, L.: Low probability of detection for underwater acoustic communication: a review. *IEEE Access* **6**, 19099–19112 (2018)
- Ding, W., et al.: A hybrid power line and visible light communication system for indoor hospital applications. *Comput. Ind.* **68**, 170–178 (2015)
- Ding, Z., Lei, X., Karagiannidis, G.K., Schober, R., Yuan, J., Bhargava, V.K.: A survey on non-orthogonal multiple access for 5G networks: research challenges and future trends. *IEEE J. Sel. Areas Commun.* **35**(10), 2181–2195 (2017)
- Ding, J., Liu, W., Zhang, H., Mei, H.: Advanced progress of optical wireless technologies for power industry: an overview. *Appl. Sci.* **10**(18), 6463 (2020)
- DLR Institute of Communications and Navigation. <https://www.dlr.de/kn/en/desktopdefault.aspx/tabid-2081/>
- Do, T.-H., Yoo, M.: Performance analysis of visible light communication using CMOS sensors. *Sensors* **16**(3), 309 (2016)
- Douik, A., Dahrouj, H., Al-Naffouri, T.Y., Alouini, M.-S.: Hybrid radio/free-space optical design for next generation backhaul systems. *IEEE Trans. Commun.* **64**(6), 2563–2577 (2016)
- Duque, A., Stanica, R., Rivano, H., Desportes, A.: Analytical and simulation tools for optical camera communications. *Comput. Commun.* **160**, 52–62 (2020)
- Elamassie, M., Uysal, M.: Vertical underwater visible light communication links: channel modeling and performance analysis. *IEEE Trans. Wirel. Commun.* **19**(10), 6948–6959 (2020)
- Feng, L., Hu, R.Q., Wang, J., Xu, P., Qian, Y.: Applying VLC in 5G networks: architectures and key technologies. *IEEE Netw.* **30**(6), 77–83 (2016)
- Ghassemlooy, Z., Arnon, S., Uysal, M., Xu, Z., Cheng, J.: Emerging optical wireless communications—advances and challenges. *IEEE J. Sel. Areas Commun.* **33**(9), 1738–1749 (2015)
- Ghassemlooy, Z., Luo, P., Zvanovec, S.: Optical camera communications. In: *Optical Wireless Communications*, pp. 547–568. Springer (2016)

- Ghosal, A., Conti, M.: Security issues and challenges in V2X: a survey. *Comput. Netw.* **169**, 107093 (2020)
- Graceffo, G.M., Talamonti, J., Campbell, L., Ashrafi, S., Kowalevicz, A.M.: Hybrid RF & FSO for defense and 5G backhaul. *IEEE Globecom Workshops (GC Wkshps)* **2019**, 1–6 (2019)
- Gulbahar, B., Sencan, S.: Wireless Internet service providing for 5G with hybrid TV broadcast and visible light communications. *Wirel. Days* **2017**, 66–69 (2017)
- Haas, H.: LiFi is a paradigm-shifting 5G technology. *Rev. Phys.* **3**, 26–31 (2018)
- Haas, H., Yin, L., Wang, Y., Chen, C.: What is lifi? *J. Light. Technol.* **34**(6), 1533–1544 (2015)
- Haas, H., et al.: Introduction to indoor networking concepts and challenges in LiFi. *J. Opt. Commun. Netw.* **12**(2), A190–A203 (2020)
- Haluška, R., Šufaj, P., Ovseník, L., Marchevský, S., Papaj, J., Doboš, E.: Prediction of received optical power for switching hybrid FSO/RF system. *Electronics* **9**(8), 1261 (2020)
- Hamza, A.S., Deogun, J.S., Alexander, D.R.: Classification framework for free space optical communication links and systems. *IEEE Commun. Surv. Tutor.* **21**(2), 1346–1382 (2018)
- Han, S., Noh, Y., Liang, R., Chen, R., Cheng, Y.-J., Gerla, M.: Evaluation of underwater optical-acoustic hybrid network. *China Commun.* **11**(5), 49–59 (2014)
- Han, S., Noh, Y., Lee, U., Gerla, M.: Optical-acoustic hybrid network toward real-time video streaming for mobile underwater sensors. *Ad Hoc Netw.* **83**, 1–7 (2019)
- Hasan, M.K., Shahjalal, M., Chowdhury, M.Z., Jang, Y.M.: Access point selection in hybrid OCC/RF Ehealth architecture for real-time remote patient monitoring. *Int. Conf. Inf. Commun. Technol. Converg. (ICTC)* **2018**, 716–719 (2018b)
- Hasan, M.K., Shahjalal, M., Chowdhury, M.Z., Hossan, M.T., Jang, Y.M.: Fuzzy logic based network selection in hybrid OCC/Li-Fi communication system. *Tenth Int. Conf. Ubiquitous Future Netw. (ICUFN)* **2018**, 95–99 (2018c)
- Hasan, M., Shahjalal, M., Chowdhury, M.Z., Jang, Y.M.: Real-time healthcare data transmission for remote patient monitoring in patch-based hybrid OCC/BLE networks. *Sensors* **19**(5), 1208 (2019a)
- Hasan, M.K., Le, N.T., Shahjalal, M., Chowdhury, M.Z., Jang, Y.M.: Simultaneous data transmission using multilevel LED in hybrid OCC/LiFi system: concept and demonstration. *IEEE Commun. Lett.* **23**(12), 2296–2300 (2019b)
- Hasan, M., Chowdhury, M.Z., Shahjalal, M., Jang, Y.M.: Fuzzy based network assignment and link-switching analysis in hybrid OCC/LiFi system. *Wirel. Commun. Mob. Comput.* **2018** (2018)
- Hossan, M., Chowdhury, M.Z., Islam, A., Jang, Y.M.: A novel indoor mobile localization system based on optical camera communication. *Wirel. Commun. Mob. Comput.* **2018** (2018)
- Hu, P., Pathak, P.H., Das, A.K., Yang, Z., Mohapatra, P.: PLiFi: hybrid WiFi-VLC networking using power lines. In: *Proceedings of the 3rd Workshop on Visible Light Communication Systems*, pp. 31–36 (2016)
- Huang, S., Safari, M.: Spectrum trading in hybrid RF/FSO communications: a stackelberg game approach. *IEEE Wirel. Commun. Netw. Conf. (WCNC)* **2020**, 1–6 (2020)
- Huang, Z., et al.: Hybrid optical wireless network for future SAGO-integrated communication based on FSO/VLC heterogeneous interconnection. *IEEE Photonics J.* **9**(2), 1–10 (2017)
- Ijaz, A., et al.: Enabling massive IoT in 5G and beyond systems: PHY radio frame design considerations. *IEEE Access* **4**, 3322–3339 (2016)
- Islim, M.S., Haas, H.: Modulation techniques for Li-Fi. *ZTE Commun.* **14**(2), 29–40 (2019)
- Islam, K.Y., Ahmad, I., Habibi, D., Zahed, M. I. A., Kamruzzaman, J.: Green underwater wireless communications using hybrid optical-acoustic technologies. *IEEE Access*, vol. PP, 1 (2021). <https://doi.org/10.1109/ACCESS.2021.3088467>
- Jaffe, J.S.: Underwater optical imaging: the past, the present, and the prospects. *IEEE J. Ocean. Eng.* **40**(3), 683–700 (2014)
- James Singh, K., et al.: Micro-LED as a promising candidate for high-speed visible light communication. *Appl. Sci.* **10**(20), 7384 (2020)
- Ji, R., Wang, S., Liu, Q., Lu, W.: High-speed visible light communications: enabling technologies and state of the art. *Appl. Sci.* **8**(4), 589 (2018)
- Jin, F., Zhang, R., Hanzo, L.: Resource allocation under delay-guarantee constraints for heterogeneous visible-light and RF femtocell. *IEEE Trans. Wirel. Commun.* **14**(2), 1020–1034 (2014)
- Juels, A.: RFID security and privacy: a research survey. *IEEE J. Sel. Areas Commun.* **24**(2), 381–394 (2006)
- Kafawy, M., Fahmy, Y., Abdallah, M., Khairy, M.: A novel bandwidth and power allocation scheme for power efficient hybrid RF/VLC indoor systems. *Phys. Commun.* **31**, 187–195 (2018)
- Karunatilaka, D., Zafar, F., Kalavally, V., Parthiban, R.: LED based indoor visible light communications: state of the art. *IEEE Commun. Surv. Tutor.* **17**(3), 1649–1678 (2015)

- Katsilieris, T.D., Latsas, G.P., Nistazakis, H.E., Tombras, G.S.: An accurate computational tool for performance estimation of FSO communication links over weak to strong atmospheric turbulent channels. *Computation* **5**(1), 18 (2017)
- Kaushal, H., Kaddoum, G.: Underwater optical wireless communication. *IEEE Access* **4**, 1518–1547 (2016a)
- Kaushal, H., Kaddoum, G.: Optical communication in space: challenges and mitigation techniques. *IEEE Commun. Surv. Tutorials* **19**(1), 57–96 (2016b)
- Kaymak, Y., Rojas-Cessa, R., Feng, J., Ansari, N., Zhou, M., Zhang, T.: A survey on acquisition, tracking, and pointing mechanisms for mobile free-space optical communications. *IEEE Commun. Surv. Tutor.* **20**(2), 1104–1123 (2018)
- Kerr, A., Rafuse, H., Sparkes, G., Hinchey, J., Sandeman, H.: Visible/infrared spectroscopy (VIRS) as a research tool in economic geology: background and pilot studies from Newfoundland and Labrador. *Geol. Surv. Rep.* **11**, 145–166 (2011)
- Khalid, H., Muhammad, S.S., Nistazakis, H.E., Tombras, G.S.: Performance analysis of hard-switching based hybrid FSO/RF system over turbulence channels. *Computation* **7**(2), 28 (2019)
- Khalighi, M.A., Uysal, M.: Survey on free space optical communication: a communication theory perspective. *IEEE Commun. Surv. Tutor.* **16**(4), 2231–2258 (2014)
- Khan, L.U.: Visible light communication: Applications, architecture, standardization and research challenges. *Digit. Commun. Netw.* **3**(2), 78–88 (2017)
- Khan, M.N., Kashif, H., Rafay, A.: Performance and optimization of hybrid FSO/RF communication system in varying weather. *Photonic Netw. Commun.* **41**(1), 47–56 (2021)
- Kim, R.Y., Kwak, J.S., Etemad, K.: WiMAX femtocell: requirements, challenges, and solutions. *IEEE Commun. Mag.* **47**(9), 84–91 (2009)
- Kim, Y., Lee, S., Lee, S.: Coexistence of ZigBee-based WBAN and WiFi for health telemonitoring systems. *IEEE J. Biomed. Heal. Inform.* **20**(1), 222–230 (2015)
- Koonen, T.: Indoor optical wireless systems: technology, trends, and applications. *J. Light. Technol.* **36**(8), 1459–1467 (2017)
- Lee, I.E., Chung, G.C., Pang, W.L., Anas, S.S., Cheong, M.Y.: Design of a hybrid free space optical and visible light communication system for indoor wireless data broadcasting. *J. Phys. Conf. Ser.* **1432**(1), 12065 (2020)
- Lei, H., Dai, Z., Ansari, I.S., Park, K.-H., Pan, G., Alouini, M.-S.: On secrecy performance of mixed RF-FSO systems. *IEEE Photonics J.* **9**(4), 1–14 (2017)
- Li, Q., Yang, Y., Ma, W.-K., Lin, M., Ge, J., Lin, J.: Robust cooperative beamforming and artificial noise design for physical-layer secrecy in AF multi-antenna multi-relay networks. *IEEE Trans. Signal Process.* **63**(1), 206–220 (2014)
- Li, L., Zhang, Y., Fan, B., Tian, H.: Mobility-aware load balancing scheme in hybrid VLC-LTE networks. *IEEE Commun. Lett.* **20**(11), 2276–2279 (2016a)
- Li, Y., Cai, A., Qiao, G., Shi, L., Bose, S.K., Shen, G.: Multi-objective topology planning for microwave-based wireless backhaul networks. *IEEE Access* **4**, 5742–5754 (2016b)
- Li, X., Yu, J., Chang, G.-K.: Photonics-assisted technologies for extreme broadband 5G wireless communications. *J. Light. Technol.* **37**(12), 2851–2865 (2019)
- Liang, K., Chow, C.-W., Liu, Y.: RGB visible light communication using mobile-phone camera and multi-input multi-output. *Opt. Express* **24**(9), 9383–9388 (2016)
- Liang, S., Zhang, Y., Fan, B., Tian, H.: Multi-attribute vertical handover decision-making algorithm in a hybrid VLC-femto system. *IEEE Commun. Lett.* **21**(7), 1521–1524 (2017)
- Lin, B., Ghassemlooy, Z., Lin, C., Tang, X., Li, Y., Zhang, S.: An indoor visible light positioning system based on optical camera communications. *IEEE Photonics Technol. Lett.* **29**(7), 579–582 (2017)
- Liu, W., Xu, Z.: Some practical constraints and solutions for optical camera communication. *Philos. Trans. R. Soc. A* **378**(2169), 20190191 (2020)
- Liu, Y., Pan, G., Zhang, H., Song, M.: Hybrid decode-forward & amplify-forward relaying with non-orthogonal multiple access. *IEEE Access* **4**, 4912–4921 (2016)
- Liu, H., Zhu, P., Chen, Y., Huang, M.: Power allocation for downlink hybrid power line and visible light communication system. *IEEE Access* **8**, 24145–24152 (2020)
- Lopez-Fraguas, E., et al.: Visible light communication system using an organic emitter and a perovskite photodetector. *Org. Electron.* **73**, 292–298 (2019)
- Lopez-Ruiz, N., Lopez-Torres, J., Rodríguez, M.Á.C., de Vargas-Sansalvador, I.P., Martínez-Olmos, A.: Wearable system for monitoring of oxygen concentration in breath based on optical sensor. *IEEE Sens. J.* **15**(7), 4039–4045 (2015)
- Lorences-Riesgo, A., et al.: 200 G outdoor free-space-optics link using a single-photodiode receiver. *J. Light. Technol.* **38**(2), 394–400 (2020)

- Lorrière, N., et al.: Photovoltaic solar cells for outdoor LiFi communications. *J. Light. Technol.* **38**(15), 3822–3831 (2020)
- Lu, H., Proietti, R., Liu, G., Chen, X., Ben Yoo, S.J.: ERON: an energy-efficient and elastic RF-optical architecture for mmWave 5G radio access networks. *J. Opt. Commun. Netw.* **12**(7), 200–216 (2020)
- Luo, P., et al.: Experimental demonstration of RGB LED-based optical camera communications. *IEEE Photonics J.* **7**(5), 1–12 (2015)
- Mansour, A., Mesleh, R., Abaza, M.: New challenges in wireless and free space optical communications. *Opt. Lasers Eng.* **89**, 95–108 (2017)
- Marpaung, D., Yao, J., Capmany, J.: Integrated microwave photonics. *Nat. Photonics* **13**(2), 80–90 (2019)
- Matheus, L.E.M., Vieira, A.B., Vieira, L.F.M., Vieira, M.A.M., Gnawali, O.: Visible light communication: concepts, applications and challenges. *IEEE Commun. Surv. Tutor.* **21**(4), 3204–3237 (2019)
- Mehedi, S.A.H.M.M., Hasan, A.M., Sadiq, M.A., Akhtar, H., Islam, L.S.R.: A systematic review on practical considerations, recent advances and research challenges in underwater optical wireless communication. *IJACSA*, pp. 162–172 (2020)
- Mei, H., Ding, J., Zheng, J., Chen, X., Liu, W.: Overview of vehicle optical wireless communications. *IEEE Access* **8**, 173461–173480 (2020)
- Memedi, A., & Dressler, F.: Vehicular visible light communications: A survey. *IEEE Commun Surv Tutor* **23**(1), 161–181 (2020)
- Miladić-Tešić, S.D., Marković, G.Z., Nonković, N.P.: Optical technologies in support of the smart city concept. *Tehnika* **75**(2), 209–215 (2020)
- Milici, S., Lázaro, A., Villarino, R., Girbau, D., Magnarosa, M.: Wireless wearable magnetometer-based sensor for sleep quality monitoring. *IEEE Sens. J.* **18**(5), 2145–2152 (2018)
- Mohageg, M., Lorio, M.C., Hoppe, D.J., Huleis, J.N., Abramovici, A., Chung, S.K.: Minimizing effect of sun–earth-probe angle for RF/optical hybrid telescope. In: *Free-Space Laser Communications XXXII*, **11272**, 112720K (2020)
- Moriconi, C., Cupertino, G., Betti, S., Tabacchiera, M.: Hybrid acoustic/optic communications in underwater swarms. In: *OCEANS 2015-Genova*, pp. 1–9 (2015)
- Mostafa, A., Lampe, L.: Physical-layer security for MISO visible light communication channels. *IEEE J. Sel. Areas Commun.* **33**(9), 1806–1818 (2015)
- Mufutau, A.O., Guiomar, F.P., Fernandes, M.A., Lorences-Riesgo, A., Oliveira, A., Monteiro, P.P.: Demonstration of a hybrid optical fiber–wireless 5G fronthaul coexisting with end-to-end 4G networks. *J. Opt. Commun. Netw.* **12**(3), 72–78 (2020)
- Nadeem, F., Kvicera, V., Awan, M.S., Leitgeb, E., Muhammad, S.S., Kandus, G.: Weather effects on hybrid FSO/RF communication link. *IEEE J. Sel. Areas Commun.* **27**(9), 1687–1697 (2009)
- Nan, C., Hui, C.: Progress and prospect of high-speed visible light communication. *Opto-Electron. Eng.* **47**(03), 190687 (2020)
- NASA Technology Transfer Program “The Teletenna - A Hybrid Telescope Antenna System”. <https://technology.nasa.gov/patent/TB2016/LEWTOPS-118>
- Ndjiongue, A.R., Ngatched, T.M.N., Dobre, O.A., Armada, A.G.: VLC-based networking: feasibility and challenges. *IEEE Netw.* **34**(4), 158–165 (2020)
- Nemati, E., Deen, M.J., Mondal, T.: A wireless wearable ECG sensor for long-term applications. *IEEE Commun. Mag.* **50**(1), 36–43 (2012)
- Nguyen, D.T., Park, S., Chae, Y., Park, Y.: VLC/OCC hybrid optical wireless systems for versatile indoor applications. *IEEE Access* **7**, 22371–22376 (2019)
- Obeed, M., Salhab, A.M., Zummo, S.A., Alouini, M.-S.: Joint optimization of power allocation and load balancing for hybrid VLC/RF networks. *J. Opt. Commun. Netw.* **10**(5), 553–562 (2018)
- Oklahoma State University News “Hybrid Lunar Communication Architecture (LunarCom)-Connecting the earth and moon” https://news.okstate.edu/articles/engineering-architecturetechnology/2020/hybrid_lunar_communication_architecture_lunarcom_connecting_the_earth_and_moon.html
- Osman, R.A., Peng, X.-H., Omar, M.A.: Adaptive cooperative communications for enhancing QoS in vehicular networks. *Phys. Commun.* **34**, 285–294 (2019)
- Pan, G., Tang, C., Zhang, X., Li, T., Weng, Y., Chen, Y.: Physical-layer security over non-small-scale fading channels. *IEEE Trans. Veh. Technol.* **65**(3), 1326–1339 (2015)
- Pan, G., Ye, J., Ding, Z.: On secure VLC systems with spatially random terminals. *IEEE Commun. Lett.* **21**(3), 492–495 (2016)
- Pan, G., Ye, J., Ding, Z.: Secure hybrid VLC-RF systems with light energy harvesting. *IEEE Trans. Commun.* **65**(10), 4348–4359 (2017)
- Papanikolaou, V.K., Diamantoulakis, P.D., Sofotasios, P.C., Muhaidat, S., Karagiannidis, G.K.: On optimal resource allocation for hybrid VLC/RF networks with common backhaul. *IEEE Trans. Cognit. Commun. Netw.* **6**(1), 352–365 (2020)

- Pathak, P.H., Feng, X., Hu, P., Mohapatra, P.: Visible light communication, networking, and sensing: a survey, potential and challenges. *IEEE Commun. Surv. Tutor.* **17**(4), 2047–2077 (2015)
- Paul, B., Chiriyath, A.R., Bliss, D.W.: Survey of RF communications and sensing convergence research. *IEEE Access* **5**, 252–270 (2016)
- Peng, H., Liang, L., Shen, X., Li, G.Y.: Vehicular communications: a network layer perspective. *IEEE Trans. Veh. Technol.* **68**(2), 1064–1078 (2018)
- Persia, S., Tabacchiera, M., Betti, S.: Performance evaluation of hybrid acoustic-optical underwater swarm networks. *Sensors Transducers* **199**(4), 10 (2016)
- Pesek, P., Zvánovec, S., Chvojka, P., Ghassemlooy, Z., Haigh, P.A.: Demonstration of a hybrid FSO/VLC link for the last mile and last meter networks. *IEEE Photonics J.* **11**(1), 1–7 (2018)
- Pham, T.L., Nguyen, T., Thieu, M.D., Nguyen, H., Nguyen, H., Jang, Y.M.: An artificial intelligence-based error correction for optical camera communication. *Eleventh Int. Conf. Ubiquitous Future Netw. (ICUFN)* **2019**, 137–140 (2019)
- Poulton, C.V., et al.: Long-range LiDAR and free-space data communication with high-performance optical phased arrays. *IEEE J. Sel. Top. Quantum Electron.* **25**(5), 1–8 (2019)
- Rachim, V.P., Chung, W.-Y.: Wearable noncontact armband for mobile ECG monitoring system. *IEEE Trans. Biomed. Circuits Syst.* **10**(6), 1112–1118 (2016)
- Raible, D.E., et al.: On the physical realizability of hybrid RF and optical communications platforms for deep space applications. In: *32nd AIAA International Communications Satellite Systems Conference*, p. 4482 (2014)
- Rakia, T., Yang, H.-C., Alouini, M.-S., Gebali, F.: Outage analysis of practical FSO/RF hybrid system with adaptive combining. *IEEE Commun. Lett.* **19**(8), 1366–1369 (2015)
- Rakia, T., Gebali, F., Yang, H.-C., Alouini, M.-S.: Cross layer analysis of P2MP hybrid FSO/RF network. *J. Opt. Commun. Netw.* **9**(3), 234–243 (2017)
- Rehman, S.U., Ullah, S., Chong, P.H.J., Yongchareon, S., Komosny, D.: Visible light communication: a system perspective—overview and challenges. *Sensors* **19**(5), 1153 (2019)
- Retamal, J.R.D., et al.: 4-Gbit/s visible light communication link based on 16-QAM OFDM transmission over remote phosphor-film converted white light by using blue laser diode. *Opt. Express* **23**(26), 33656–33666 (2015)
- Rödiger, B., Ginthör, D., Labrador, J.P., Ramirez, J., Schmidt, C., Fuchs, C.: Demonstration of an FSO/RF hybrid-communication system on aeronautical and space applications. In: *Laser Communication and Propagation through the Atmosphere and Oceans IX*, **11506**, 1150603 (2020)
- Saeed, N., Celik, A., Al-Naffouri, T.Y., Alouini, M.-S.: Energy harvesting hybrid acoustic-optical underwater wireless sensor networks localization. *Sensors* **18**(1), 51 (2018)
- Saeed, N., Guo, S., Park, K.-H., Al-Naffouri, T.Y., Alouini, M.-S.: Optical camera communications: survey, use cases, challenges, and future trends. *Phys. Commun.* **37**, 100900 (2019a)
- Saeed, N., Celik, A., Al-Naffouri, T.Y., Alouini, M.-S.: Underwater optical wireless communications, networking, and localization: A survey. *Ad Hoc Netw.* **94**, 101935 (2019b)
- Saha, N., Iftekhar, M.S., Le, N.T., Jang, Y.M.: Survey on optical camera communications: challenges and opportunities. *IET Optoelectron.* **9**(5), 172–183 (2015)
- Samdanis, K., Leitão, F., Oechsner, S., Riu, J.R.I., Ros, R.D.C., Fabregas, G.: From interworking to hybrid access systems and the road toward the next-generation of fixed-mobile convergence. *IEEE Commun. Stand. Mag.* **1**(1), 36–43 (2017)
- Sarigiannidis, P., Lagkas, T., Bibi, S., Ampatzoglou, A., Bellavista, P.: Hybrid 5G optical-wireless SDN-based networks, challenges and open issues. *IET Netw.* **6**(6), 141–148 (2017)
- Saud, M.S., Katz, M.: Implementation of a hybrid optical-RF wireless network with fast network handover. In: *European Wireless 2017; 23th European Wireless Conference*, pp. 1–6 (2017)
- Schirripa Spagnolo, G., Cozzella, L., Leccese, F.: Underwater optical wireless communications: overview. *Multidisciplinary Digital Publishing Institute*, pp. 1–14 (2020)
- Sebastián, J., Lamar, D.G., Aller, D.G., Rodríguez, J., Míajia, P.F.: On the role of power electronics in visible light communication. *IEEE J. Emerg. Sel. Top. Power Electron.* **6**(3), 1210–1223 (2018)
- Shafi, M., et al.: 5G: a tutorial overview of standards, trials, challenges, deployment, and practice. *IEEE J. Sel. Areas Commun.* **35**(6), 1201–1221 (2017)
- Shao, S., et al.: Design and analysis of a visible-light-communication enhanced WiFi system. *J. Opt. Commun. Netw.* **7**(10), 960–973 (2015)
- Shao, S., et al.: An indoor hybrid WiFi-VLC internet access system. In: *2014 IEEE 11th International Conference on Mobile Ad Hoc and Sensor Systems*, pp. 569–574 (2014)
- Sohn, I., Jang, Y.H., Lee, S.H.: Ultra-low-power implantable medical devices: optical wireless communication approach. *IEEE Commun. Mag.* **58**(5), 77–83 (2020)
- Son, I.K., Mao, S.: A survey of free space optical networks. *Digit. Commun. Netw.* **3**(2), 67–77 (2017)

- Spahiu, C.S., Stanescu, L., Brezovan, M., Petcusin, F.: LiFi technology feasibility study for car-2-car communication. In: 2020 21th International Carpathian Control Conference (ICCC), pp. 1–5 (2020)
- Spanò, E., Di Pascoli, S., Iannaccone, G.: Low-power wearable ECG monitoring system for multiple-patient remote monitoring. *IEEE Sens. J.* **16**(13), 5452–5462 (2016)
- Tabish, R., et al.: A 3G/WiFi-enabled 6LoWPAN-based U-healthcare system for ubiquitous real-time monitoring and data logging. In: 2nd Middle East Conference on Biomedical Engineering, pp. 277–280 (2014)
- Taher, M.A., Abaza, M., Fedawy, M., Aly, M.H.: Relay selection schemes for FSO communications over turbulent channels. *Appl. Sci.* **9**(7), 1281 (2019)
- Takai, I., Harada, T., Andoh, M., Yasutomi, K., Kagawa, K., Kawahito, S.: Optical vehicle-to-vehicle communication system using LED transmitter and camera receiver. *IEEE Photonics J.* **6**(5), 1–14 (2014)
- Teli, S., Cahyadi, W.A., Chung, Y.H.: Optical camera communication: Motion over camera. *IEEE Commun. Mag.* **55**(8), 156–162 (2017)
- Thieu, M.D., Pham, T.L., Nguyen, T., Jang, Y.M.: Optical-RoI-signaling for vehicular communications. *IEEE Access* **7**, 69873–69891 (2019)
- Tian, P., et al.: High-speed underwater optical wireless communication using a blue GaN-based micro-LED. *Opt. Express* **25**(2), 1193–1201 (2017)
- Touati, A., Abdaoui, A., Touati, F., Uysal, M., Bouallegue, A.: On the effects of combined atmospheric fading and misalignment on the hybrid FSO/RF transmission. *J. Opt. Commun. Netw.* **8**(10), 715–725 (2016)
- Tsai, W.-S., Li, C.-Y., Lu, H.-H., Lu, Y.-F., Tu, S.-C., Huang, Y.-C.: 256 Gb/s four-channel SDM-based PAM4 FSO-UWOC convergent system. *IEEE Photonics J.* **11**(2), 1–8 (2019)
- Tseng, K.C., Lin, B.-S., Liao, L.-D., Wang, Y.-T., Wang, Y.-L.: Development of a wearable mobile electrocardiogram monitoring system by using novel dry foam electrodes. *IEEE Syst. J.* **8**(3), 900–906 (2013)
- Tsonev, D., Videv, S., Haas, H.: Light fidelity (Li-Fi): towards all-optical networking. *Broadband Access Commun. Technol.* **VIII 9007**, 900702 (2014)
- Tsonev, D., Videv, S., Haas, H.: Towards a 100 Gb/s visible light wireless access network. *Opt. Express* **23**(2), 1627–1637 (2015)
- Uema, H., Matsumura, T., Saito, S., Murata, Y.: Research and development on underwater visible light communication systems. *Electron. Commun. Jpn.* **98**(3), 9–13 (2015)
- Vats, A., Aggarwal, M., Ahuja, S.: Outage and error analysis of three hop hybrid VLC/FSO/VLC-based relayed optical wireless communication system. *Trans. Emerg. Telecommun. Technol.* **30**(5), e3544 (2019)
- Wang, Y., Haas, H.: Dynamic load balancing with handover in hybrid Li-Fi and Wi-Fi networks. *J. Light. Technol.* **33**(22), 4671–4682 (2015)
- Wang, C., Yu, H.-Y., Zhu, Y.-J.: A long distance underwater visible light communication system with single photon avalanche diode. *IEEE Photonics J.* **8**(5), 1–11 (2016)
- Wang, J., Jiang, C., Zhang, H., Zhang, X., Leung, V.C.M., Hanzo, L.: Learning-aided network association for hybrid indoor LiFi-WiFi systems. *IEEE Trans. Veh. Technol.* **67**(4), 3561–3574 (2017a)
- Wang, Y., Wu, X., Haas, H.: Load balancing game with shadowing effect for indoor hybrid LiFi/RF networks. *IEEE Trans. Wirel. Commun.* **16**(4), 2366–2378 (2017b)
- Wang, J., Shi, W., Xu, L., Zhou, L., Niu, Q.: Design of optical-acoustic hybrid underwater wireless sensor network. *J. Netw. Comput. Appl.* **92**, 59–67 (2017c)
- Wang, J., Shao, Y., Ge, Y., Yu, R.: A survey of vehicle to everything (V2X) testing. *Sensors* **19**(2), 334 (2019)
- Waterhouse, R., Novack, D.: Realizing 5G: microwave photonics for 5G mobile wireless systems. *IEEE Microw. Mag.* **16**(8), 84–92 (2015)
- Watson, S., et al.: High speed visible light communication using blue GaN laser diodes. *Adv. Free-Space Opt. Commun. Tech. Appl. II 9991*, 99910A (2016)
- Wei, L., Hu, R.Q., Qian, Y., Wu, G.: Key elements to enable millimeter wave communications for 5G wireless systems. *IEEE Wirel. Commun.* **21**(6), 136–143 (2014)
- Wei, Z., et al.: 2 Gbps/3 m air-underwater optical wireless communication based on a single-layer quantum dot blue micro-LED. *Opt. Lett.* **45**(9), 2616–2619 (2020)
- Wu, W.: Spectrum sensing in optical wireless communication network. *Trans. Emerg. Telecommun. Technol.* **31**(4), e3716 (2020)
- Wu, F., Chen, L., Wang, W.: HRO-OFDM scheme design and optimization for a hybrid RF/VLC baseband system. *IEEE Photonics J.* **9**(5), 1–13 (2017)

- Wu, Z.-Y., Ismail, M., Serpedin, E., Wang, J.: Data-driven link assignment with QoS guarantee in mobile RF-Optical HetNet of things. *IEEE Internet Things J.* **7**(6), 5088–5102 (2020a)
- Wu, X., Soltani, M.D., Zhou, L., Safari, M., Haas, H.: Hybrid LiFi and WiFi networks: a survey. *IEEE Commun. Surv. Tutor.* **23**(2), 1398–1420 (2021a)
- Wu, Q., Zhang, S., Zheng, B., You, C., Zhang, R.: Intelligent reflecting surface aided wireless communications: a tutorial. *IEEE Trans. Commun.* **69**(5), 3313–3351 (2021b)
- Wu, F., Wu, T., Yuce, M.R.: Design and implementation of a wearable sensor network system for IoT-connected safety and health applications. In: 2019 IEEE 5th World Forum on Internet of Things (WF-IoT), pp. 87–90 (2019)
- Wu, Z.-Y., Ismail, M., Serpedin, E.: Data-driven smart handover in mobile RF/optical HetNets. In: 2020 IEEE 10th International Conference on Intelligent Systems (IS), pp. 322–327 (2020)
- Yang, C., Shao, H.-R.: WiFi-based indoor positioning. *IEEE Commun. Mag.* **53**(3), 150–157 (2015)
- Yang, Y., Zeng, Z., Cheng, J., Guo, C.: A novel hybrid dimming control scheme for visible light communications. *IEEE Photonics J.* **9**(6), 1–12 (2017)
- Yang, H., Marzetta, T.L.: A macro cellular wireless network with uniformly high user throughputs. In: 2014 IEEE 80th Vehicular Technology Conference (VTC2014-Fall), pp. 1–5 (2014)
- Yaqoob, I., Hashem, I.A.T., Mehmood, Y., Gani, A., Mokhtar, S., Guizani, S.: Enabling communication technologies for smart cities. *IEEE Commun. Mag.* **55**(1), 112–120 (2017)
- Yasir, M., Ho, S.-W., Vellambi, B.N.: Indoor positioning system using visible light and accelerometer. *J. Light. Technol.* **32**(19), 3306–3316 (2014)
- Yoo, J.-H., Jang, J.-S., Kwon, J.K., Kim, H.-C., Song, D.-W., Jung, S.-Y.: Demonstration of vehicular visible light communication based on LED headlamp. *Int. J. Automot. Technol.* **17**(2), 347–352 (2016)
- You, X., Chen, J., Yu, C.: Efficient indoor data transmission with full dimming control in hybrid visible light/infrared communication systems. *IEEE Access* **6**, 77675–77684 (2018)
- You, X., Chen, J., Yu, C.: Performance of location-based equalization for OFDM indoor visible light communications. *IEEE Trans. Cognit. Commun. Netw.* **5**(4), 1229–1243 (2019)
- Younus, O.I., et al.: Data rate enhancement in optical camera communications using an artificial neural network equaliser. *IEEE Access* **8**, 42656–42665 (2020)
- Yu, C., You, X., Liu, Z., Chen, J.: Conceptual design for indoor visible light communication and positioning cooperative systems. In: 2020 22nd International Conference on Transparent Optical Networks (ICTON), pp. 1–4 (2020)
- Zafar, F., Bakaul, M., Parthiban, R.: Laser-diode-based visible light communication: toward gigabit class communication. *IEEE Commun. Mag.* **55**(2), 144–151 (2017)
- Zaman Chowdhury, M., Khalid Hasan, M., Shahjalal, M., Tanvir Hossain, M., Jang, Y.M.: Optical wireless hybrid networks for 5G and beyond communications. *arXiv e-prints*, p. arXiv-2006, (2020)
- Zeng, Z., Fu, S., Zhang, H., Dong, Y., Cheng, J.: A survey of underwater optical wireless communications. *IEEE Commun. Surv. Tutor.* **19**(1), 204–238 (2017). <https://doi.org/10.1109/COMST.2016.2618841>
- Zeng, Z., Soltani, M.D., Wang, Y., Wu, X., Haas, H.: Realistic indoor hybrid WiFi and OFDMA-based LiFi networks. *IEEE Trans. Commun.* **68**(5), 2978–2991 (2020)
- Zhang, D., Zhou, Z., Mumtaz, S., Rodriguez, J., Sato, T.: One integrated energy efficiency proposal for 5G IoT communications. *IEEE Internet Things J.* **3**(6), 1346–1354 (2016)
- Zhang, Y., Wang, L., Wang, K., Wong, K.S., Wu, K.: Recent advances in the hardware of visible light communication. *IEEE Access* **7**, 91093–91104 (2019)
- Zhang, Z., Chaaban, A., Lampe, L.: Physical layer security in light-fidelity systems. *Philos. Trans. r. Soc. A* **378**(2169), 20190193 (2020a)
- Zhang, D., N'Doye, I., Ballal, T., Al-Naffouri, T.Y., Alouini, M.-S., Laleg-Kirati, T.-M.: Localization and tracking control using hybrid acoustic-optical communication for autonomous underwater vehicles. *IEEE Internet Things J.* **7**(10), 10048–10060 (2020b)
- Zhou, K., Gong, C., Wu, N., Xu, Z.: Distributed channel allocation and rate control for hybrid FSO/RF vehicular ad hoc networks. *IEEE/OSA J. Opt. Commun. Netw.* **9**(8), 669–681 (2017)
- Zhou, H., Xu, W., Chen, J., Wang, W.: Evolutionary V2X technologies toward the internet of vehicles: challenges and opportunities. *Proc. IEEE* **108**(2), 308–323 (2020)
- Zhuang, Y., et al.: A survey of positioning systems using visible LED lights. *IEEE Commun. Surv. Tutor.* **20**(3), 1963–1988 (2018)

Authors and Affiliations

Syed Agha Hassnain Mohsan¹  · Hussain Amjad²

✉ Syed Agha Hassnain Mohsan
Hassnainagha@zju.edu.cn

¹ Zheda Road 1, Zhoushan 316021, Zhejiang, China

² Satellite Communication and Networking Laboratory, Ocean College, Zhejiang University, Zheda Road 1, Zhoushan 316021, Zhejiang, China