

# THE USE OF THERMOGRAVIMETRIC ANALYSIS TECHNIQUE FOR THE CHARACTERIZATION OF CONSTRUCTION MATERIALS

## The gypsum case

M. V. Borrachero, J. Payá\*, M. Bonilla and J. Monzó

Grupo de Investigación en Química de los Materiales de Construcción (GIQUIMA) Instituto de Ciencia y Tecnología del Hormigón ICITECH, Universidad Politécnica de Valencia, Camino de Vera s/n. 46071 Valencia, Spain

The thermogravimetric analysis (TG) technique is widely used in the characterization of diverse types of construction materials related to binders, such as plasters, limes and cements. For calcium sulphate dihydrate (gypsum) two serial dehydration steps are very near in temperature decomposition and overlapping in the thermogravimetric events is observed. The goal of this research is to develop new thermogravimetric analysis procedures that allow obtaining more precise information in the characterization of plasters. The resolution of both dehydration events has been increased using two different strategies: on one hand, the production in the experience of a water vapour self-generated atmosphere by the use of sealed aluminium pan with a pinholed lid. On the other hand, the use of high resolution thermogravimetric analysis (HRTG), based on the variation of the heating rate as a function of the rate of mass loss observed at once. The results obtained for both strategies of improvement of the TG curves, showed that they are two procedures that let to obtain a total resolution of the two dehydration steps for gypsum.

**Keywords:** crucible type, gypsum, heating rate, HRTG, thermogravimetry

## Introduction

The thermogravimetric analysis technique (TG) studies the variation of mass that a material undergoes when this material is subjected to temperature change [1]. This variation of mass is usually a loss of mass, and it is caused because, during the heating process, different chemistry reactions are produced, where volatile compounds are formed. These reactions would be combustion, dehydration, decomposition, etc. [2, 3].

This technique is usually being used for the characterization of construction materials related to binders, e.g. hydrated lime [4], gypsum [5, 6] cement [7], clays [8] and also is used in studies of gypsum obtained in other conditions [9]. On these materials, thermogravimetric events have been observed for wide temperature ranges. The temperature range depends on the following parameters:

### Sample

The sample must have an appropriate fineness, because granulometry influence on decomposition temperatures [10]. Moreover, the sample amount must be sufficiently great for evaluation of the variation of mass, and sufficiently small for obtaining narrow temperature range events, yielding quasi-vertical mass-loss steps [2]. Additionally, sometimes, the derivative curve DTG is simultaneously registered, for better resolution of thermogravimetric events [1].

### Crucibles

The size, composition and geometry of the recipients, where the sample will be contained could make changes on event temperature ranges [2].

### Atmosphere

The realization of an experiment can be carried out under an inert or reactive atmosphere. This last one implies that chemical reaction takes place between the substance that is into the pan and the atmosphere that surrounds it. Sometimes, changes in atmosphere nature are proposed, to a given temperature for characterizing a material, as the case of the determination of coal in the fly ashes [11]. Finally, we should keep in mind that with the use of a current of gas inside the furnace and near the pan, the generated gaseous products are dragged. Thus, if the crucible is open, the vapour pressure of the formed gaseous product on the sample will be low, and the temperature of decomposition will be diminished. However, if we can make that in certain measure, the atmosphere generated by the reaction is confined into the crucible an increase of the vapour pressure will take place inside the recipient, which will increase the temperature of decomposition [12, 13]. Also, the use of a self-generated atmosphere can allow to separate two very near serial processes when they have the same gaseous product as a consequence of the reaction [1].

\* Author for correspondence: jjpaya@cst.upv.es

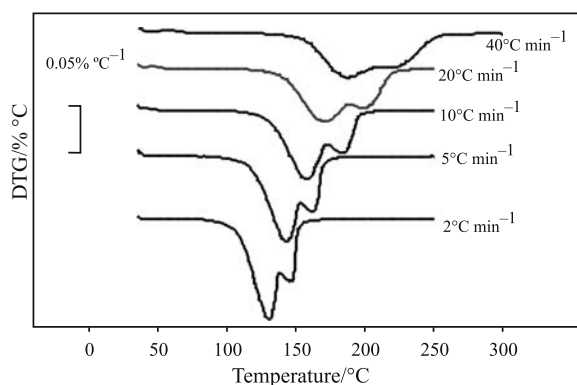

**Table 1** Thermogravimetric values for the dehydration of gypsum at different heating rates

Heating rate/ $^{\circ}\text{C min}^{-1}$	Temperatures of maximum mass loss rate		Onset 1 <sup>st</sup> event/ $^{\circ}\text{C}$	Endset 2 <sup>nd</sup> event/ $^{\circ}\text{C}$	Temp. change/ $^{\circ}\text{C}$
	1 <sup>st</sup> event	2 <sup>nd</sup> event			
2	131.4	147.6	119.17	153.3	139.21
5	145	162.92	131.8	170.9	153.1
10	159	184.5	144.5	195.8	175.5
20	172.3	201.67	156.7	216.9	190.0
40	190.3	223	174.8	244.32	209.0

both mass losses cannot be carried out at temperature ranges where both reactions may occur.

It has been tried to separate the two chemical processes diminishing the heating rate. Thus, experiences were designed where dihydrate samples were heated in alumina pan, at different heating rates, in the 2–40 $^{\circ}\text{C min}^{-1}$  range. In the Fig. 3, the DTG curves of the decompositions with different heating rates are observed. It is shown that although the tested heating rate is very low (2 $^{\circ}\text{C min}^{-1}$ ), the complete separation of both dehydration processes is not possible: endset temperature (the temperature at which the event can be considered as finished) for the first decomposition and the onset temperature (the temperature at which the event has begun) for the second decomposition are overlapped. This behaviour could be due to the activation energy of the first reaction is higher or the same as the activation energy of the second reaction [15]. In the Table 1, different thermogravimetric values are summarized: the onset temperature values for the first decomposition and the endset temperature value for the second decomposition (that is onset/endset for the global transformation of dihydrate to anhydrite), temperatures at which the mass loss rate was maximum, and the temperature in the overlapping zone at which the mass loss rate changes in slope (change temperature). It is observed, in general, that a decrease of the heating rate produces a decrease in the decomposition temperature range as expected at its end.



**Fig. 3** DTG curves for dihydrate samples in alumina crucible, with different heating rates (sample mass: 25 mg)

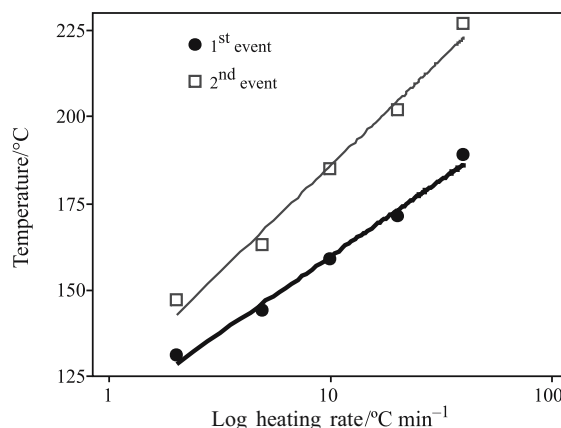

**Fig. 4** Logarithmic relationship for both decomposition steps between the temperatures of maximum mass loss rate and the heating rate

A good logarithmic relationship is obtained when these parameters are plotted vs. the heating rate, according to the following equation:

$$\Phi = a \ln \Theta + b$$

Being  $\Phi$  the temperature (in  $^{\circ}\text{C}$ ) of the DTG curve parameter,  $\Theta$  the heating rate (in  $^{\circ}\text{C min}^{-1}$ ),  $a$  and  $b$  constants for the regression fit. For instance, in the Fig. 4 the heating rate has been plotted vs. the temperatures of maximum decomposition rate for both events. In Fig. 4 also is observed that the difference for a given heating rate between maximum decomposition rate temperatures increases with the heating rate. The regression parameters are summarized in Table 2.

**Table 2** Logarithmic relationships for different decomposition parameters

Thermogravimetric parameters	$a$	$b$	$R^2$
Maximum mass loss rate 1 <sup>st</sup> event	16.53	112.42	0.982
Maximum mass loss rate 2 <sup>nd</sup> event	25.07	121.10	0.978
Onset 1 <sup>st</sup> event	18.35	103.97	0.986
Endset 2 <sup>nd</sup> event	30.69	126.95	0.985
Temperature change	23.79	119.65	0.988

To attempt give a practical use of the results shown in Fig. 4 and Table 1, selected data have been used to estimate the activation energy of both gypsum decompositions steps (events 1<sup>st</sup> and 2<sup>nd</sup>), by using the Kissinger equation [18], applied to each step.

The equation was developed by Kissinger to use DTA peak temperatures. In this case, maximum decomposition rate values obtained from DTG peaks have been used [19] for fitting the regression. The Kissinger equation is the following:

$$\ln\left(\frac{\Theta}{T_m^2}\right) = \ln\left(\frac{AR}{E}\right) - \frac{E}{RT_m}$$

where  $T_m$  is the absolute temperature at which maximum reaction rate occurs (K),  $\Theta$  is the heating rate ( $\text{K min}^{-1}$ ),  $A$  is the pre-exponential factor ( $\text{min}^{-1}$ ),  $R$  is the gas constant ( $8.314 \text{ J mol}^{-1} \text{ K}^{-1}$ ), and  $E$  is the activation energy ( $\text{J mol}^{-1}$ ).

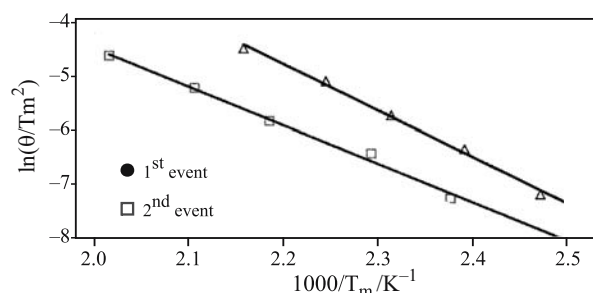

**Fig. 5** Kissinger plots for 1<sup>st</sup> and 2<sup>nd</sup> decomposition events for gypsum

Figure 5 shows  $\ln\left(\frac{\Theta}{T_m^2}\right)$  vs.  $1000/T_m$  plot, and the

activation energy is calculated directly in  $\text{kJ mol}^{-1}$ , for both events. In Table 3, the regression parameters from the Kissinger plots for each event are summarized, and the estimated activation energy values ( $E$ ) are calculated together the pre-exponential factor ( $A$ ). It is observed that the highest value of activation energy was observed for the first event ( $71.86 \text{ kJ mol}^{-1}$ ). The activation energy value for the first event is slightly smaller than those found by other authors [20, 21]. This behavior can be due to the use of DTG peaks instead of DTA peaks for the estimation, and also can be attributed to the sample origin, sample mass or its fineness.

### Influence of the crucible type

In order to get the separation of both events for gypsum dehydration (dehydrate form), an experimental set was designed to produce a self-generated atmosphere inside the crucible. In this case, the water vapour pressure will be increased and will force the second reaction of dehydration from the hemihydrate to anhydrite to take place at higher temperatures. This change would allow us to separate the two events. Thus, an experience was programmed, using  $100 \mu\text{L}$  aluminium pan which were sealed using a pinhole ( $80 \mu\text{m}$  in diameter) aluminium lid. So, the water that evaporates during the first process (dihydrate to hemihydrate), could be in certain measure confined inside the crucible, and consequently, increasing the pressure of water vapour. The heating rate was  $20^\circ\text{C min}^{-1}$ . In the Fig. 6a, the TG and DTG curves for this experience are depicted. A better resolution is observed with respect to those found using alumina pan, although a certain degree of overlapping was also observed, since the DTG curve did not reached  $0\% \text{ } ^\circ\text{C}^{-1}$  value again, between the first and the second process. To improve this resolution, similar experience was repeated diminishing the heating rate at  $10^\circ\text{C min}^{-1}$ . The TG and DTG corresponding curves are shown in Fig. 6b. It is observed that in this last experience, both

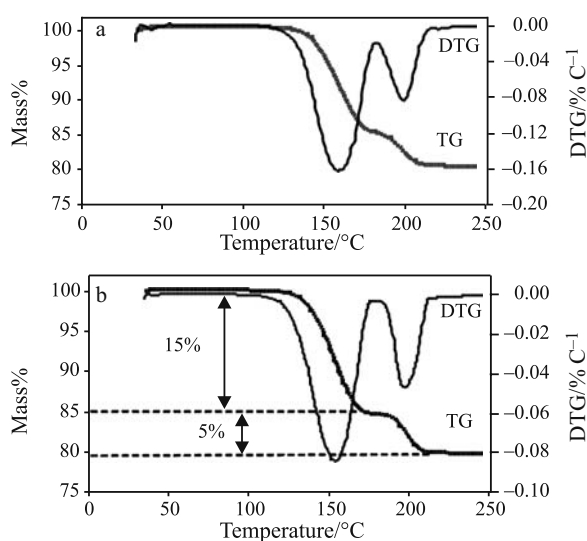
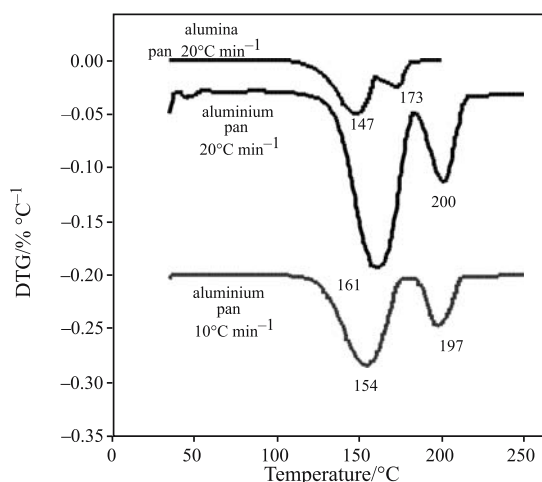

**Fig. 6** TG and DTG curves for the decomposition of the dihydrate using  $100 \mu\text{L}$  sealed aluminium pan: a –  $20^\circ\text{C min}^{-1}$ ; b –  $10^\circ\text{C min}^{-1}$  heating rate (sample mass:  $25 \text{ mg}$ )

**Table 3** Regression parameters from Kissinger equation for gypsum decomposition

Step	Slope	Origin ordinate	$R^2$	$E/\text{kJ mol}^{-1}$	$A/\text{min}^{-1}$
1 <sup>st</sup> event	-8.64	14.24	0.995	71.86	13227
2 <sup>nd</sup> event	-7.18	9.87	0.992	59.67	138.7





**Fig. 7** Temperatures of maximum mass loss rate for different experimental conditions in the dehydration of gypsum: effect of the crucible type and heating rate

processes have completely separated, what allows us to evaluate, easily and with precision, the mass losses. The ratio of the mass losses between the two processes was practically 3:1, in accordance with the stoichiometry of the reactions (1) and (2).

However, it is important to observe that with the modification of the conditions of the experiment, a change in the dehydration temperatures is produced. These modifications are summarized in Fig. 7, where the temperatures for maximum mass loss rates in both events are indicated for each experience conditions. It can be noted that the formation of a water vapour self-generated atmosphere makes that the temperatures of decomposition are higher, while when the heating rate is lower, the temperatures of the processes are slightly diminished.

#### Study of the decomposition of gypsum using of HRTG

Usually, the TG experiments are normally constituted by one or more stages in which the heating rate is previously defined, independently of the involved processes and of their kinetics. An alternative consists on the use of an adaptive event-controlled heating rate as a function of the evolution of the sample. Thus, the heating rate ( $V_t$ ) is continuously and dynamically varied to maximize the resolution according to the mass loss rate ( $V_m$ ), that is the heating rate is very low in the steps involved with significant mass loss, and increases in the contrary case. The software for this type of applications (the one used in these experiences was MaxRes of Mettler Toledo) consists basically on the previous determination of four following parameters:

- Maximum heating rate:  $V_{tmax}$
- Minimum heating rate  $V_{tmin}$
- Maximum rate of mass loss:  $V_{mmax}$
- Minimum rate of mass loss:  $V_{mmin}$

When the mass loss rate is smaller than the minimum one predetermined ( $V_{mmin}$ ), the heating rate  $V_t$  is progressively increased to the maximum heating rate ( $V_{tmax}$ ). In this way, for steps where the sample does not present significant variations of mass, the lapsed time is small. On the contrary, when the mass loss rate is higher than the maximum established ( $V_{mmax}$ ) the heating rate  $V_t$  is gradually decreased to the minimum one predetermined ( $V_{tmin}$ ). This way, the jumps are more vertical and the overlapping decrease among serial processes, due to the decomposition is carried out practically in quasi-isothermal conditions. In Fig. 8, a scheme of the followed process in HRTG is shown.

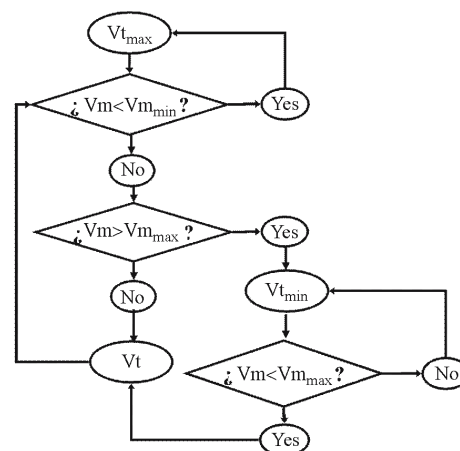

**Fig. 8** Scheme of the process for heating rate control in the HRTG

This HRTG technique was applied for studying a sample of dihydrate,  $\text{CaSO}_4 \cdot 2\text{H}_2\text{O}$ , in order to improve the total resolution of both dehydration processes. Also, a crucible with sealed aluminium pinhole lid was used, to produce a self-generated atmosphere. The conditions of the experience are shown in Table 4.

In Fig. 9a, the TG and DTG curve are shown, and in Fig. 9b a comparison between the TG curves obtained with and without the use of HRTG control is shown. It can be noted that this high resolution technique allows the highest resolution of the curves, producing jumps of mass loss the most vertical shape, and demonstrating its viability for the study on this type of samples. Besides the high resolution observed when the HRTG is applied, it must be highlighted the fact that the expended time to obtain the HRTG curve, is very similar to the expended time for a conventional TG analysis carried out at  $10^\circ\text{C min}^{-1}$ , as can be seen in Fig. 9c.

In the HRTG, the first decomposition is produced in the  $140\text{--}154^\circ\text{C}$  range (Fig. 10, the heating rate was  $V_{tmin}=1^\circ\text{C min}^{-1}$ ), finding a maximum mass loss rate ( $3\% ^\circ\text{C}^{-1}$ , from Fig. 9a) at  $146^\circ\text{C}$ . At higher temperatures,

**Table 4** Experimental conditions used in the experience with the HRTG

Crucible	Heating range	Atmosphere	$V_{\text{tmax}}$	$V_{\text{tmin}}$	$V_{\text{mmax}}$	$V_{\text{mmin}}$
Aluminum, 100 $\mu\text{L}$ sealed	35–250°C	$\text{N}_2$ , 75 $\text{mL min}^{-1}$	$20^\circ\text{C min}^{-1}$	$1^\circ\text{C min}^{-1}$	$3 \mu\text{g s}^{-1}$	$1 \mu\text{g s}^{-1}$

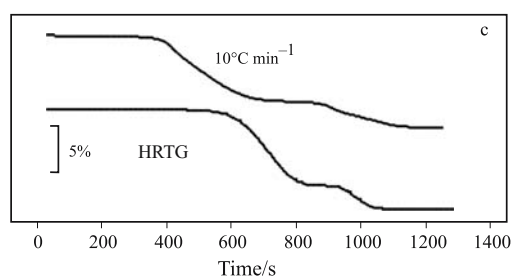
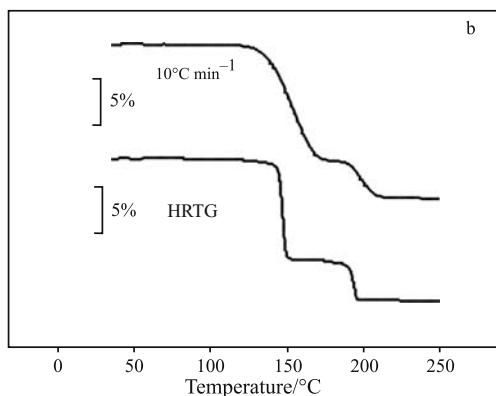
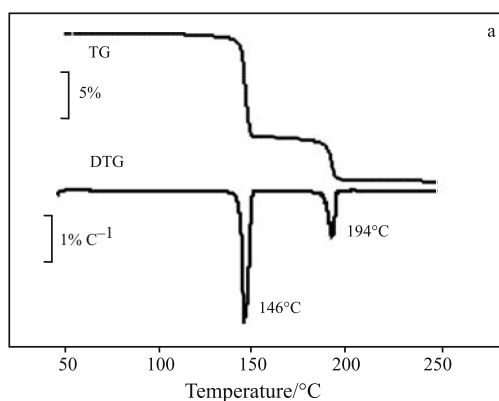

**Fig. 9** a – TG and DTG curves for dihydrate decomposition using HRTG (sample mass 25 mg); b – Comparison of TG curves for the dihydrate decomposition with and without the use of HRTG; c – Expanded time in the HRTG and predefined heating rate techniques

the second decomposition event is observed, also in a narrow temperature range (188–199°C, according to Fig. 10), finding the highest mass loss rate at 194°C ( $0.9\% \text{ }^\circ\text{C}^{-1}$ ; Fig. 9a). For furnace temperature ranges in which changes in mass were negligible (e.g. 50–140, 160–185 and 205–250°C) the reached heating rate was the maximum  $V_{\text{tmax}}$  ( $20^\circ\text{C min}^{-1}$ ).

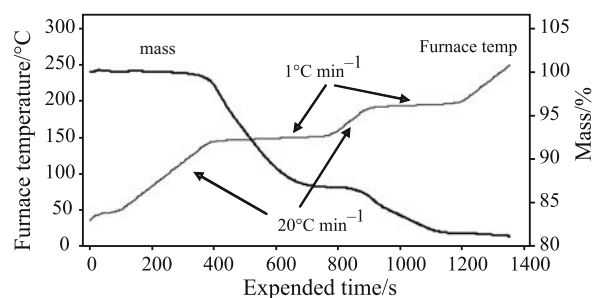

**Fig. 10** Changes in furnace temperature and mass with time in HRTG experience on dihydrate sample

## Conclusions

The gypsum decomposes in two serial processes which are very near in temperature. In the study of these decompositions using thermogravimetric analysis technique, the conditions of the experiences may be extremely considered.

It has been observed that is not possible to separate completely both dehydration processes for gypsum using an alumina crucible. Good logarithmic relationships between thermogravimetric parameters (e.g.: the first decomposition onset temperature, the second decomposition endset temperature, temperatures at which the mass loss rate was maximum, and change temperature) and heating rate were obtained. Also, activation energy for both decomposition events, calculated using the Kissinger equation, have been estimated: It is observed that the highest value of activation energy was observed for the first event ( $71.86 \text{ kJ mol}^{-1}$ ).

The use of sealed aluminium crucibles containing a pinholed lid lets one to obtain a good resolution for medium heating rate values, due to the effect of the water vapour self-generated atmosphere. In these conditions, precise calculation of the both step mass losses for gypsum (dihydrated form) can be carried out.

An alternative method to separate both decomposition processes for gypsum is the use of the high resolution thermogravimetric analysis technique (HRTG), being obtained, in this case, total resolution of both decomposition processes and TG curves with mass ‘jumps’ of practically vertical shape, which facilitate its evaluation. The use of HRTG does not necessarily imply an increase in the expended analysis time.

## References

- 1 P. J. Haines, 'Thermal Methods of Analysis' Blackie Academic Professional (1995).
- 2 M. E. Brown, Introduction to Thermal Analysis Technique and Applications, Chapman and Hall (1998).
- 3 J. W. Dodd and K. H. Tonge, Thermal Methods, J. Wiley and Sons (1987).
- 4 S. Vecchio, A. La Ginestra, A. Frezza and C. Ferragine, *Thermochim. Acta*, 227 (1993) 215.
- 5 D. L. Hudson-Lamb, C. A. Strydom and J. H. Potgieter, *J. Thermochim. Acta*, 282/283 (1996) 486.
- 6 M. Anastasiou, Th. Hasapis, T. Zorba, E. Pavlidou, K. Chrissafis and K. M. Paraskevopoulos, *J. Therm. Anal. Cal.*, 84 (2006) 27.
- 7 V. S. Ramachandran, Applications of Differential Thermal Analysis in Cement Chemistry, Chemical Publishing Company (1969).
- 8 Y. Xi, W. Martens, H. He and R. L. Frost, *J. Therm. Anal. Cal.*, 81 (2005) 91.
- 9 A. Aagli, N. Tamer, A. Atbir, L. Boukbir and M. El Hadek, *J. Therm. Anal. Cal.*, 82 (2005) 395.
- 10 A. M. Mellado, J. Payá, M. V. Borrachero and J. Monzó, 2<sup>nd</sup> International Conference on Instrumental Methods of Analysis, IMA, Ioanna (Grecia) 2001 p. 132.
- 11 J. Payá, J. Monzó, M. V. Borrachero, F. Amahjour and E. Peris-Mora, *J. Chem. Technol. Biotechnol.*, 77 (2002) 251.
- 12 J. Payá, J. Monzó, M. V. Borrachero, S. Velázquez and M. Bonilla, *Cem. Concr. Res.*, 33 (2003) 1085.
- 13 J. Payá, J. Monzó, M. V. Borrachero and S. Velázquez, *Cem. Concr. Res.*, 33 (2003) 603.
- 14 M. Matteini and A. Moles, *Química en la restauración*, Nerea 2001.
- 15 D. Fatu, *J. Therm. Anal. Cal.*, 65 (2001) 213.
- 16 F. Paulik, J. Paulik and M. Arnold, *Thermochim. Acta*, 200 (1992) 195.
- 17 E. Todorova, *J. Thermal Anal.*, 46 (1996) 187.
- 18 H. E. Kissinger, *Anal. Chem.*, 29 (1957) 1702.
- 19 J. Dweck, R. S. Aderne and D. J. Shanefield, *J. Therm. Anal. Cal.*, 64 (2001) 1163.
- 20 C. A. Strydom, D. L. Hudson-Lamb, J. H. Potgieter and E. Dagg, *Thermochim. Acta*, 269/270 (1995) 631.
- 21 I. Y. Elbeyli and S. Piskin, *J. Hazard. Mater.*, 116 (2004) 111.

---

Received: June 19, 2006

Accepted: July 18, 2007

---

DOI: 10.1007/s10973-006-7739-3