



New measurement of the ^{238}U decay constant with inductively coupled plasma mass spectrometry

Tashi Parsons-Davis¹ · Josh Wimpenny¹ · C. Brenhin Keller^{2,3} · Keenan Thomas¹ · Kyle M. Samperton¹ · Paul R. Renne^{2,3} · Roland Mundil³ · Ken Moody¹ · Kim Knight¹ · Michael J. Kristo¹ · Ross Williams¹

Received: 1 June 2018 / Published online: 22 August 2018
© Akadémiai Kiadó, Budapest, Hungary 2018

Abstract

The ^{238}U decay constant ($\lambda_{\text{U-238}}$) is fundamental to radioisotope-based chronometry in the Earth and planetary sciences, yet only a single published $\lambda_{\text{U-238}}$ value (Jaffey et al. in *Phys Rev C* 4(5):1889–1906, 1971) is widely applied. We have determined $\lambda_{\text{U-238}}$ via the novel approach of measuring of ^{234}Th ingrowth in high-purity ^{238}U solutions, using isotope dilution mass spectrometry (ID-MS). The ^{234}Th decay constant ($\lambda_{\text{Th-234}}$) was measured via decay counting with high-purity Ge (HPGe) γ detectors. Preliminary results for $\lambda_{\text{U-238}}$ agree with the value determined by α -counting [1] within the elevated uncertainty of 0.462% ($k = 2$). Ongoing efforts to reproduce $\lambda_{\text{U-238}}$ with reduced experimental uncertainties will inform future conclusions.

Keywords Uranium · Thorium · Half-life · Decay constant · Radiochronometry · Inductively coupled plasma mass spectrometry

Introduction

Radioisotopic dating techniques are unique in their ability to provide accurate and precise absolute temporal constraints on past physical and chemical events and processes recorded in present day materials. As such, these techniques are important in fields ranging from planetary sciences to nuclear sciences, with processes-of-interest occurring on timescales of years to billions of years. However, radioisotopic dating is directly dependent on

accurate knowledge of decay constants and their uncertainties. A recent report [2] on the current state of geochronology highlights the growth of high-precision uranium-lead geochronological techniques and their potential role in addressing key questions regarding, for example, the evolution of life and the interconnection between terrestrial geochemical systems and climate variability. The importance of accurate and precise decay constants for uranium-series, uranium-lead, and lead-lead dating applied to calibrating the geologic timescale has been emphasized by the geochronology community for years [2–6]. In recent decades mass spectrometric analytical techniques have advanced such that the accuracy and precision of radioisotopic dates are now often limited by knowledge of the decay constants rather than the analytical uncertainty in parent/daughter isotope measurements.

The decay constants for α -decay of ^{238}U and ^{235}U ($\lambda_{\text{U-238}}$ and $\lambda_{\text{U-235}}$, respectively) are particularly significant to Earth science, as they limit the accuracy and precision of uranium-lead and lead-lead ages that are frequently used, particularly for constraining events and processes that occurred over 1.5 billion years ago [7]. Furthermore, $\lambda_{\text{U-238}}$ serves as the ‘gold standard’ timekeeper in geochronology applications across most of galactic history, and as a calibration benchmark for other decay schemes used in chronology [8]. The ‘canonical’

Electronic supplementary material The online version of this article (<https://doi.org/10.1007/s10967-018-6148-y>) contains supplementary material, which is available to authorized users.

✉ Tashi Parsons-Davis
parsonsdavis1@llnl.gov

¹ Nuclear and Chemical Sciences Division, Lawrence Livermore National Laboratory, P.O. Box 808 L-231, Livermore, CA 94551, USA

² Department of Earth and Planetary Science, University of California Berkeley, 307 McCone Hall, Berkeley, CA 94720, USA

³ Berkeley Geochronology Center, 2455 Ridge Road, Berkeley, CA 94709, USA

λ_{U-238} and λ_{U-235} values widely applied in geo-/radiochronometry were determined by defined solid angle α -counting with high internal precision ($\sim 0.13\%$, $k = 2$) [1]. However, these values have not been independently verified with comparable precision since their initial publication nearly 50 years ago. Thus, much of the absolute timescale of Earth history is tied to the accuracy of a single measurement. This situation is less than ideal, particularly as possible systematic uncertainties and biases were not incorporated into the uncertainties reported by Jaffey et al. [1]. Some systematic differences have been observed between $^{207}\text{Pb}/^{206}\text{Pb}$, $^{207}\text{Pb}/^{235}\text{U}$ and $^{206}\text{Pb}/^{238}\text{U}$ dates [4], which raises concern that at least one of uncertainties from Jaffey et al. [1], which are commonly applied in geochronology, was underestimated. Evaluations from leading scientific organizations [5, 6, 9, 10] have dismissed other previously-published λ_{U-238} measurements based on lack of experimental details or untested assumptions of secular equilibrium in natural uranium samples, and simply recommended the values reported in Jaffey et al. [1]. However, the most recent evaluations [4–6] recommend doubling the uncertainty reported in [1], based on the possibility of systematic bias, and emphasize the need for new, independent λ_{U-238} measurements.

The medium-geometry α counting measurements of 99.9790–99.9997 at% ^{238}U sources were carefully executed and thoroughly described by Jaffey et al. [1]. However, considering the steps involved, and the difficulty of quantifying counting sources with $< 0.1\%$ accuracy, the possibility of unknown systematic bias cannot be dismissed. As such, we aimed to verify their λ_{U-238} using a completely independent approach, via extraction and measurement of ingrown ^{234}Th in chemically-purified, isotopically-enriched ^{238}U solutions. This method relies on the availability of gram quantities of an isotopically pure ^{238}U material with low ^{234}U abundance, careful yield tracing, accurate measurements using isotope dilution multi-collector inductively coupled plasma mass spectrometry (ID-MC-ICP-MS), and an accurately known value for λ_{Th-234} . However, no measurements of λ_{Th-234} have been published since 1948 [11], in which the value was reported with much lower uncertainty than previous measurements [12, 13] and thus dominates the weighted average. A recent evaluation recommended that new measurements of λ_{Th-234} should be undertaken [14]. Consequently, as part of our overall effort to verify λ_{U-238} , we also report here our preliminary λ_{Th-234} value from measured ^{234}Th decay curves.

Experimental

Uranium-238 decay constant experimental overview

Figure 1 summarizes our novel approach to determining λ_{U-238} , which was enabled by the availability of significant quantities of “Q-metal” uranium, containing $> 99.96\%$ ^{238}U and only ~ 3 parts per million (ppm) ^{234}U (isotopic composition given in Table S1). Ingrowth of the ^{234}Th daughter into purified aliquots of Q-metal solution (5–7 g uranium in 4 M $\text{HNO}_3/0.005$ M HF) was measured after different lengths of time (Δt_1), nominally between 45 and 140 days. All quantitative measurements were achieved with ID-MC-ICP-MS. The ingrown thorium was extracted after Δt_1 , sub-aliquots analysed to determine yields, and the bulk later quantified as ^{234}U after ≥ 10 ^{234}Th half-lives (Δt_2). The uranium solutions were spiked with ^{232}Th for yield tracing in both extractions. Thorium extractions were achieved by LaF_3 co-precipitation, and for the second extraction (after Δt_1) followed by purification of Th via anion exchange in HCl.

Preparation of ^{238}U aliquots and first thorium extraction

Ultra-high purity distilled acids (Seastar) were used throughout the experiment unless otherwise noted, and all perfluoroalkoxy alkane (PFA) Teflon vials and tubes were purchased from Savillex and acid-leached prior to use. The master solution containing 42.25 g uranium was dried down in a PFA bottle and fumed to dryness in concentrated HNO_3 several times, then dissolved in approximately 250 mL 4 M $\text{HNO}_3/0.005$ M HF and spiked with 10 μg ^{232}Th , which served as a thorium yield tracer. The ^{232}Th tracer was a gravimetrically prepared solution of thorium metal from Ames Laboratory dissolved in HNO_3 . The thorium recoveries were determined by ID-MC-ICP-MS using an in-house ^{229}Th spike calibrated using ^{230}Th standard reference material from the National Institute of Standards and Technology, NIST SRM 4342A [16]. The same ^{229}Th spike was used for all thorium recovery determinations, so the absolute concentration value and uncertainty for this spike factored out in yield calculations. Throughout the experiment, gentle heat (between 70 and 110 °C) and sonication were used to homogenize solutions. After thorough mixing, six sub-aliquots (~ 0.35 g uranium in each) were weighed into PFA vials for analysis, and remaining uranium solution was weighed into twelve 50-mL PFA centrifuge tubes, where each aliquot (A-F) constituted 6–8 g uranium distributed into two tubes, then diluted with 4 M $\text{HNO}_3/0.005$ M HF to ~ 30 mL per tube.

Fig. 1 Schematic overview **a** of ^{234}Th ingrowth experiment that was designed as an independent measurement of $\lambda_{\text{U-}^{238}}$, with the t_0 and t_1 chemical separations summarized in **b**. Six aliquots of 99.96% ^{238}U were chemically-purified to establish the beginning time ($t = 0$) and were quantified by uranium isotope dilution–mass spectrometry ($\text{U}_{\text{ID}}\text{-MS}$) using the $^{233}\text{U}/^{236}\text{U}$ double-spike from the Institute for Reference Materials and Measurements (IRMM-3636, [15]) before decaying for different ingrowth periods (Δt_1). Ingrown thorium was extracted and purified after Δt_1 , and small aliquots were removed for yield measurements via thorium isotope dilution mass spectrometry using a ^{229}Th spike ($\text{Th}_{\text{ID}}\text{-MS}$). The bulk extracted Th aliquots decayed to ^{234}U over > 10 ^{234}Th half-lives (Δt_2), then measured by $\text{U}_{\text{ID}}\text{-MS}$. The number of ^{234}U atoms measured in each aliquot after Δt_2 reveals the number of ^{238}U atoms that decayed during Δt_1

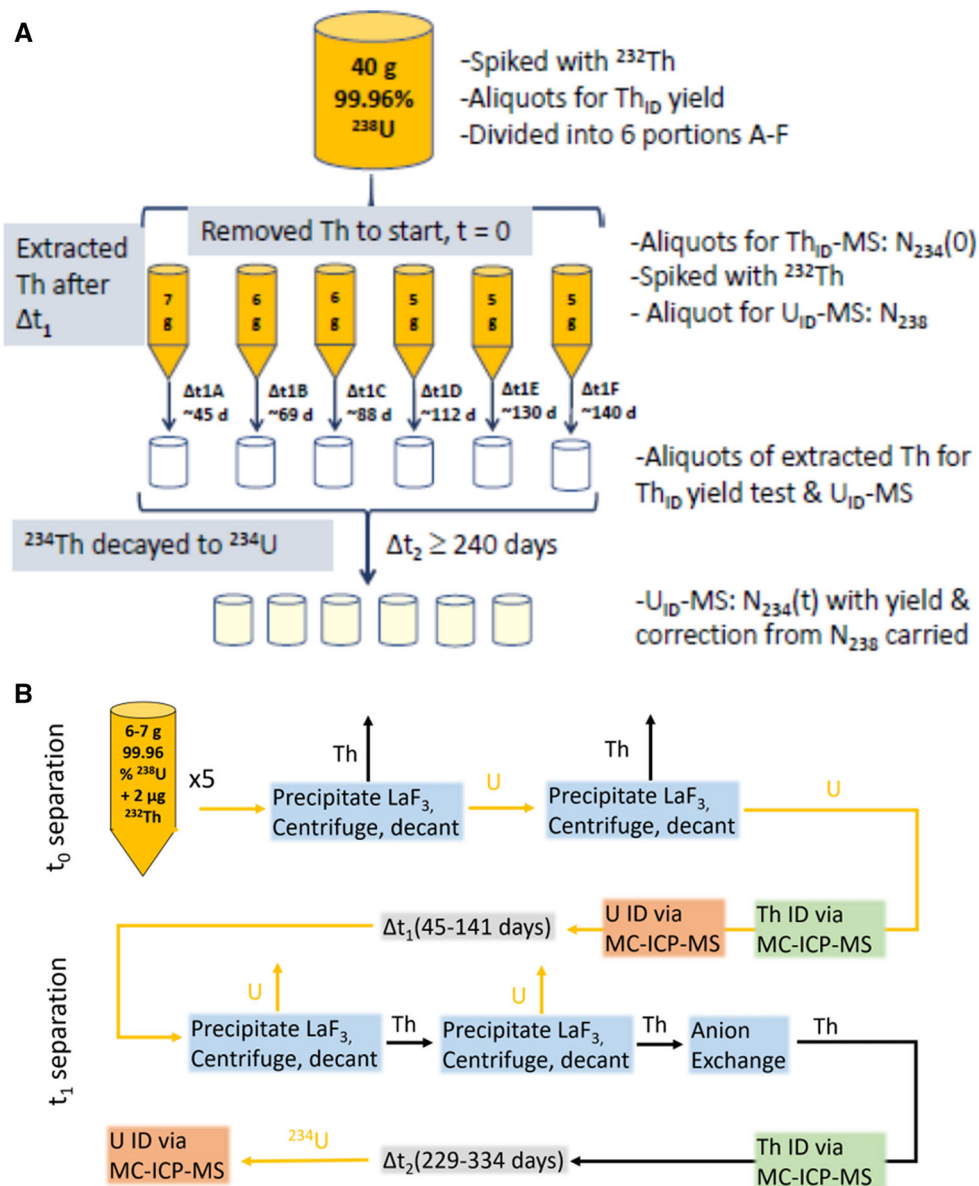

All weights were averages of three or more measurements on calibrated Mettler-Toledo or Sartorius analytical balances, checked using a common certified calibration weight set. Each aliquot was individually purified of thorium to establish ingrowth start time ($t = 0$), using LaF_3 coprecipitation with 2 mg La (99.99% LaOH_3 , Sigma-Aldrich, dissolved in 8 M HNO_3), then concentrated HF to total ~ 35 mL 4 M HF. The tubes were balanced and centrifuged for 8 min at 3500 rpm, then the uranium solution decanted into clean tubes. The precipitate was washed with 30 mL of 4 M $\text{HNO}_3/6$ M HF solution and centrifuged again. Time-stamps were recorded at each step of all chemical separations, and a combination of Geiger-Müller counting and γ counting with a high-purity Ge (HPGe) detector was used to track ^{234}Th . The goal of the first

extraction was to quickly remove thorium and establish a consistent $t = 0$ for each uranium aliquot; the purity of the extracted thorium was inconsequential. Therefore, only one wash step was completed, and the supernatant was recombined with the aliquot only if good phase separation was achieved during decanting, giving a supernatant sufficiently low in γ activity. The total time between first HF addition and decanting of the wash solution ranged 31–43 min. The purified uranium aliquots were dried down, fumed in concentrated HNO_3 at least 5 times, then 70% HClO_4 added to eliminate any trace LaF_3 particles carried over, and HNO_3 added several more times before dissolving in 4 M $\text{HNO}_3/0.005$ M HF. All chemistry steps throughout the experiment included process blanks that were measured with samples. Sub-aliquots of the uranium

solutions were removed for thorium ID-MC-ICP-MS analysis after the initial purification, to determine the thorium extraction yield.

Preparation of ^{238}U aliquots and second thorium extraction

After the first extraction, the aliquots each ranged from 4.41 to 6.76 g uranium, stored in 50 mL PFA tubes as approximately 45 mL 4 M HNO_3 /0.005 M HF solutions. Each aliquot was again spiked with 1.35 μg ^{232}Th for yield tracing, and thoroughly homogenized before sub-aliquots representing approximately 1% of the total were weighed out for uranium and thorium analysis. The second thorium extraction from each aliquot began with the same steps described above for the first extraction, but this time focus was shifted to maximizing the thorium yield and decontamination from uranium. Therefore, when significant ^{234}Th was still detected by γ counting the supernatant, an additional 1 mg La carrier was added to repeat the coprecipitation. In cases where significant UO_2F_2 precipitated, a second wash with 4 M HNO_3 /6 M HF solution was performed. When the preliminary phase separation was deemed satisfactory, all LaF_3 pellets carrying thorium from a single uranium aliquot were dissolved by fuming 70% HClO_4 , followed by concentrated HCl, and combined into a 15 mL PFA centrifuge tube. Quantitative transfer was confirmed by γ counting the empty vessels. The lanthanum and thorium solution was brought to 10 mL in 3 M HCl, then 1.33 mL HF was added to perform a second precipitation. After decanting, the precipitate was fumed in 70% HClO_4 , followed by concentrated HCl, twice each. The sample was then dissolved in 0.25 mL 9 M HCl and loaded onto a plastic Environmental Express column with approximately 5 mL resin bed of pre-cleaned Biorad AG1-X8 anion exchange resin, conditioned in 9 M HCl. Successive vial washes with 9 M HCl were loaded onto the column, totalling 3–4 bed volumes, and the eluted thorium was collected in a pre-weighed, 30-mL PFA vial. The solution was dried down, fumed three times with several drops of concentrated HNO_3 , dissolved in 25 mL 4 M HNO_3 /0.005 M HF, warmed, and sonicated to homogenize. The total time between initial HF addition and final column elution ranged from 227 to 299 min. When the vial had cooled to ambient room temperature, the weight was recorded and a sub-aliquot constituting approximately 3% of the total was removed and weighed for thorium yield and uranium carry-over measurements. The remaining solution was sealed and allowed to decay to ^{234}U for between 229 and 334 days.

Quantification of ^{238}U in mother aliquots

Approximately 25% of each of the 3% sub-aliquots removed from the mother solution prior to second extraction was used to prepare duplicate dilutions, from which four secondary dilutions were prepared (for measurements in three separate mass spectrometry campaigns) to give total dilution factors of $\sim 4 \times 10^5$. Uranium isotope dilution was performed using IRMM-3636, which is certified for isotope ratios ($^{233}\text{U}/^{236}\text{U}$ of 1.01906 ± 0.00016) and assay [15]. For this study, the certified isotope ratio was used, but the ^{233}U concentration assay of the primary IRMM-3636 solution was recalibrated against several dissolved uranium metal standards to $6.45902\text{E}14 \pm 4.12\text{E}11$ atoms/g ($k = 2$). All uranium measurements were performed by MC-ICP-MS (Nu Plasma HR, Nu Instruments, Wrexham, U.K.) with all isotopes measured statically on Faraday detectors equipped with $10^{11} \Omega$ amplifiers. The relative efficiencies of the Faraday cups were empirically intercalibrated, and Faraday pre-amplifier gain calibration was performed prior to each analytical session. Samples were input using a CETAC autosampler and Aridus-II desolvating nebulizer to improve sensitivity and reduce oxide formation. Typical sensitivity using this setup was ~ 500 V U/ppm. Uranium-233 was used for isotope dilution calculations, while $^{233}\text{U}/^{236}\text{U}$ was monitored to internally correct for mass-dependent fractionation, as neither isotope was present in the samples. Each analysis consisted of 30×8 s integrations, and outliers were excluded if they were more than 2.5 standard deviations away from the mean, approximately the 99% confidence interval. The number of ^{238}U atoms in each aliquot (N_{238} in Eq. 1) was determined from average ^{238}U concentration data collected by uranium ID-MS and the total solution weight.

Determination of thorium extraction yields

The yields of the first extractions were determined by quantifying the relative abundance of ^{232}Th tracer in the mother uranium solution before and after thorium extraction. Thorium isotope dilution measurements were performed using a ^{229}Th spike solution that was calibrated as described above. Sub-aliquots of the mother uranium solution taken before and after the first extraction were spiked with ^{229}Th , the Th purified from uranium via anion exchange and TEVA columns, and measured back-to-back by MC-ICP-MS, using the same instrumental setup as the uranium ID-MS measurements. Mass bias effects were corrected based on repeat analysis of the uranium standard NBL U010 (New Brunswick Laboratory [17]), and comparison of measured and certified values. Duplicate sub-

aliquots of the mother uranium solution before the second extraction, and of the extracted thorium, were spiked and measured similarly to determine the second extraction yields, which ranged from 94.7 to 99.2%, and were determined with relative uncertainties between 0.12 and 0.24% ($k = 2$). The U to Th ratio in the extracted Th aliquots ranged between 0.03 and 1.0, and spiked sub-aliquots were further purified by anion exchange and TEVA columns prior to analysis. The yields of the first extraction were used to determine the initial ^{234}Th atoms at $t = 0$ ($N_{234}(0)$ in Eq. 1; see below) by assuming secular equilibrium prior to initial extraction (i.e., where the master solution had last been purified 3 years prior).

Measurement of ingrown ^{234}Th as ^{234}U

The extracted thorium aliquots decayed for a period ranging from 229 to 303 days and were quantified as ^{234}U using isotope dilution with between 0.27 and 0.49 g IRMM 3636 spike solution diluted to $9.97532(644) \times 10^{11}$ ($k = 2$) atoms g^{-1} . The six extractions were completed at separate times but were spiked and measured concurrently. Samples were spiked five months prior to analysis (ranging from 106 to 180 days after extraction) and warmed to 110 °C for several days after spiking. Immediately prior to mass spectrometry, spiked solutions were dried down, dissolved in 4 M HNO_3 , and purified on a UTEVA column, all in a clean-room environment. Great care was taken to clean all reagents and minimize the uranium blank, as the number of ^{234}U atoms measured in the aliquots ranged from 1.48×10^{11} to 1.98×10^{11} . For sample analysis, all isotopes were measured on Faraday detectors, with typical intensities of the ingrown ^{234}U signal ~ 10 mV. Mass bias was corrected using the IRMM-3636 double spike. Procedural blanks were analysed with ^{234}U on the ion counter. Faraday-to-ion counter relative gain factor was calculated empirically by analysis of NBL U010 standard within the same analytical session. The $^{238}\text{U}/^{235}\text{U}$ ratios measured in the samples were used with the ^{238}U signal intensity to calculate the ^{234}U signal intensity correction for uranium carry-over and blank contribution. $^{238}\text{U}/^{235}\text{U}$ ratios observed in the samples were assumed to be dominated by Q-metal (2607.08) with a small contribution from a measured lab blank that was slightly enriched in ^{235}U ($^{238}\text{U}/^{235}\text{U} \sim 26.61$). The correlated $^{234}\text{U}/^{238}\text{U}$ values were consistent with those measured in procedural blanks and were multiplied by the ^{238}U signal intensities to yield the ^{234}U signal intensity correction for uranium carry-over and blank. The number of ^{234}U atoms measured by uranium ID-MS in each aliquot was adjusted to account for the thorium yield in the second extraction and the sub-aliquots removed, as well as the tiny fraction that had not yet decayed to ^{234}U after Δt_2 , to give $N_{234}(t)$ in Eq. 1.

Calculation of the ^{238}U decay constant

The half-life of ^{238}U is sufficiently long ($t_{1/2} \sim 4.468 \times 10^9$ years) that the number of ^{238}U atoms in each aliquot (N_{238}) was effectively constant over the course of the experiment. The Bateman equation [18] was therefore rearranged to solve for $\lambda_{\text{U-238}}$ using experimentally-measured quantities from each aliquot (Eq. 1), taking the following form:

$$\lambda_{238} = \lambda_{234} \times \frac{\left(\frac{N_{234}(t)}{N_{238}} - \frac{N_{234}(0)}{N_{238}} e^{-\lambda_{234}t}\right)}{\left(\frac{N_{234}(t)}{N_{238}} - \left(\frac{N_{234}(0)}{N_{238}} - 1\right) e^{-\lambda_{234}t} + 1\right)} \quad (1)$$

In Eq. 1, t is the time of ingrowth (Δt_1 in Fig. 1), λ_{238} is the ^{238}U decay constant, λ_{234} is the ^{234}Th decay constant, N_{238} is the number of ^{238}U atoms in the aliquot (i.e., the same at times 0 and t , within analytical resolution), $N_{234}(0)$ is the number of ^{234}Th atoms present in the aliquot after the first purification at $t = 0$, and $N_{234}(t)$ is the number of ^{234}Th atoms in the aliquot at time = t (measured as ^{234}U after Δt_2).

Due to the proliferation of covariances in the uncertainty for $\lambda_{\text{U-238}}$ (as introduced by, for example, the same spike and same spike composition measurement being used in multiple uranium ID-MS measurements), a purely analytical error propagation would be highly complex. Instead, a Monte Carlo numerical approach (e.g., Metropolis and Ulam [19]) was found to be most appropriate for this purpose. In this approach, as implemented in a MATLAB code, each measured or known (literature) value was represented numerically as a vector of 10^7 pseudorandom numbers drawn from the appropriate statistical distribution. Due to the convolution of numerous sources of noise in a single analytical measurement (e.g., gravimetric or mass spectrometric), analytical values were assumed, because of the Central Limit Theorem, to follow a Gaussian distribution, defined by two familiar parameters: a mean and a standard deviation. The full distribution of each measured or known variable, represented numerically as a 10^7 -element vector, was then propagated by element-wise addition and multiplication through a set of simple equations representing chemical separation, spiking, and dilution, accounting for the continuous radiogenic ingrowth and decay of ^{234}Th throughout the t_0 separation, Δt_1 ingrowth period, t_1 separation, and Δt_2 conversion period.

The effective primary ^{234}Th ingrowth times and their uncertainties were accurately calculated in this manner, taking into consideration the recorded times of each analytical operation (centrifuging, decanting, etc.) and approximate uranium and thorium distributions (estimated with uncertainties based on γ count data, process knowledge, and measured overall yields) at each stage of both t_0

and t_1 chemical separations. Decay and ingrowth in each step were calculated starting with the evaluated literature values and uncertainties of $\lambda_{\text{Th-234}}$ and $\lambda_{\text{U-238}}$ [6, 14], then iteratively calculated using the result of this study. Calculated ingrowth times were shorter than nominal ingrowth times because of the decay of ^{234}Th during purification, with this effect increasing as ingrowth times approached secular equilibrium. The calculation of $\lambda_{\text{U-238}}$ was completed with the evaluated $\lambda_{\text{Th-234}}$ [14] and its uncertainty, and again with the results of this study included.

^{234}Th decay curve measurements

Our new measurement of $\lambda_{\text{Th-234}}$ was achieved by gamma-counting ^{234}Th sources continuously for six half-lives, and least-squares fitting these data to the exponential decay function. The following paragraphs describe experimental parameters used for source preparation, decay counting, and data reduction.

^{234}Th for decay counting was extracted from commercial depleted uranium (see Table S2 for isotopic composition) via LaF_3 co-precipitation with multiple washes and purified by anion exchange in 9 M HCl followed by anion exchange in 8 M HNO_3 . To ensure isotopic purity of Th, the source uranium used had been chemically purified four times prior to extracting Th for counting sources. Thorium oxide counting sources were prepared by molecular deposition onto aluminium disks [20]. Other sources were prepared by drop-deposition of ^{234}Th in 2 M HNO_3 /0.005 M HF solution with 10 ppm zirconium carrier onto stainless steel planchettes. The surfaces of all counting sources were protected by affixing a 3.6 μm film of Mylar over them.

Decay curve measurements began 10 days after source preparation, allowing ^{231}Th extracted from the DU to decay prior to data collection. Two sources (one electrodeposited and one drop-deposited) were counted with HPGe detectors. The first source was counted on the detector endcap, approximately 7 mm from an Ortec GEM140 ps p-type coaxial HPGe detector (88.6 mm(d) \times 105.4 mm (h)) with 140% relative efficiency and a 3.5 mm aluminium window. The second source was counted 8.6 cm from an Ortec GEMFX8530 semi-planar detector (85 mm(d) \times 33 mm (h)) with a 0.76 mm carbon composite window. A Berkeley Nucleonics Model PB-5 pulse generator set at 5 counts per second (cps) with a pulse height 5.4 V (corresponding to 2553 keV in the calibrated spectrum) was employed for timing and electronic stability monitoring. An ^{241}Am sealed point calibration source from Eckert and Ziegler Isotope Products was used as a check on overall detector stability including the crystal. The ^{234}Th source and ^{241}Am check source were taped onto shelves on an acrylic rack with the entire assembly inside a copper-lined 10.16 cm

lead shield. The source was fixed inside a plastic petri slide container (Analyslide, Millipore), and sandwiched between a 0.635 cm acrylic absorber on the side facing the detector and a 1.27 cm thick PTFE block on the top side facing the lead shield. Both setups used an Ortec DSPEC 50 for bias supply and electronic signal processing, with a data acquisition loop in Maestro software to save the spectrum and restart the count every 2 h. Table 1 summarizes the counting conditions for the two sources.

After applying several different peak-fitting algorithms to the data, it was decided that a simple region-of-interest (ROI) binning method would be least subject to bias from slight drifts in peak shape with a changing continuum. ROIs were selected to include each peak of interest, and background ROIs were defined on either side to include the flattest possible parts of the continuum surrounding the peak and averaged for background subtraction. The background ROIs were selected to be as wide as possible while maintaining a flat continuum free from interfering peaks. The narrowest background region used was 4 channels, in between the 59.5 keV ^{241}Am ROI and 63.3 keV ROI from ^{234}Th in the spectra measured with the semi-planar detector, where the continuum was flat, and the two peaks well resolved. The net integrals in ROIs surrounding the 1001 keV peak from $^{234\text{m}}\text{Pa}$ decay and 63.3 keV from ^{234}Th decay in each 2-h count of the second measurement were divided by the net integral of the ^{241}Am ROI the same spectrum, to minimize the effects of changing dead time and any detector instability as the source decayed. The same treatment could not be used for the spectra collected on the coaxial detector, as the 59.9 keV and 63.3 keV peaks were not sufficiently resolved. Thus, only the 1001 keV ROI was used from the first data set and was divided by the net integral of the ROI containing the pulsar peak, which should minimize the effects of deadtime but would not capture any drift in the response of the detector crystal. The decay curves were fit by least squares to exponential decay function in which the free parameters were the decay constant, initial activity, and a constant on-peak background. Long background spectra were collected before and after each run, where no peaks were observed in the ROIs of interest in the semi-planar spectra, and a small 1001 keV peak was observed in the large coaxial detector background.

Results and discussion

^{234}Th decay constant

As noted by Luca [14], the four previously-published ^{234}Th half-life values were all measured before 1950 [11–13, 21], long before the advent of semiconductor detectors.

Table 1 Summary of ^{234}Th decay counting conditions

Source	^{234}Th 1	^{234}Th 2
Detector	140% coax. HPGe	Semi-planar HPGe
Activity at start (kBq)	~22	~52
Count duration (<i>d</i>)	145.8	154.6
Initial dead time (%)	1.67	1.18
Final dead time (%)	0.64	0.56
Initial count rate 59.5 keV (s^{-1})	Not used	24.06
Final count rate 59.5 keV (s^{-1})	Not used	24.10
Initial count rate 63.3 keV (s^{-1})	Not used	27.95
Final count rate 63.3 keV (s^{-1})	Not used	0.339
Initial count rate 1001 keV (s^{-1})	4.45	1.03
Final count rate 1001 keV (s^{-1})	0.075	0.012

Advantages of the HPGe detector compared to a Geiger counter (such as that used by Knight and Macklin [11]) include lower sensitivity to radioactive contaminants and modern electronics that allow spectra to be collected continuously without re-positioning the source. Disadvantages include reduced counting statistics due to lower detection efficiency, and the need for peak-fitting to remove the Compton continuum. Two peaks were examined, the 63.3 keV peak from ^{234}Th decay, and the 1001 keV peak from its daughter $^{234\text{m}}\text{Pa}$, which, with a half-life of 1.16 ± 0.01 min, is in secular equilibrium with ^{234}Th . The decay curves plotted from the 63 keV and 1001 keV ROI net integrals in the spectra collected on the semi-planar HPGe yielded consistent results (see Fig. S1), and the result from the 63 keV curve was averaged with that from the 1001 keV curve collected in the first source decay measurement. In the first source measurement, the ^{241}Am peak could not be used as the check source because of insufficient resolution and the changing Compton continuum. Based on the minimal drift observed in the normalized ^{241}Am peak area in second data set, where the peak was well-resolved, we guessed that unaccounted for detector efficiency drift in the first data set could be up to 0.1%. The detector used in the second source measurement was far better suited to resolve these peaks, but there appeared to be a systematic difference between the half-life derived from the ^{234}Th net ROIs normalized to the ^{241}Am ROIs (24.169 ± 0.016 days, $k = 2$: from fit and counting statistics) and those normalized to the pulsar ROIs (24.136 ± 0.014 days, $k = 2$: from fit and counting statistics). We chose to use the data normalized to the ^{241}Am peak, because the residuals showed more long-term structure in the pulsar-normalized data, indicating either instability in the pulsar or drift in detection efficiency. This result appears slightly discordant with that from the first measurement (24.122 ± 0.034 days, $k = 2$: from fit and counting statistics) if only the uncertainties in decay-curve fits are considered, but instead potential systematic

uncertainties were scrutinized as recommended by Pommé et al. [22, 23]. The weighted average decay constant derived is $3.321(10) \times 10^{-7} \text{ s}^{-1}$, corresponding to a half-life of 24.157 ± 0.074 days, with $k = 2$. The derived half-life is 0.24% longer than the current evaluated half-life of 24.10 ± 0.06 days ($k = 2$) but the two are in good agreement.

Figure 2 shows a plot of the residuals relative to the standard deviation of each data point as a function of time in the 63.3/59.5 keV γ ray curve collected from the second ^{234}Th source (see Fig. S2 for similar plot from first source measurement). Overall the residuals follow a nearly Gaussian distribution, with $\sim 64\%$ residual values falling within 1 standard deviation of the mean and $\sim 92\%$ falling within 2 standard deviations of the mean, derived from the observed counts. Therefore, we estimated that any short-term instabilities or fluctuations in the detection system are of similar magnitude to fluctuations from Poisson counting statistics. The residuals do show some slightly sinusoidal structure on approximately the 30-day timescale,

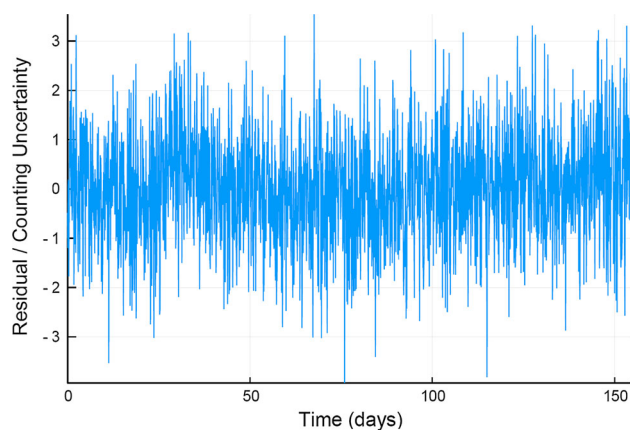

Fig. 2 Residuals, relative to statistical counting uncertainty, from least-squares fit to curve generated by net 63.3 keV ROI integrals normalized to 59.5 keV net integrals plotted over time from the measurement of ^{234}Th source 2

presumably reflecting additional unknown sources of detector instability or background fluctuations during the measurement campaign. The long-term detection efficiency stability was estimated at 0.14% by comparing the ^{241}Am count rates in 24-h periods at the beginning and end of the campaign. The decay-constant uncertainty derived from the least-squares fit was only 0.07% ($k = 2$), but the total combined uncertainty is dominated by the estimated contribution from medium-term instabilities observed in the residuals. The uncertainty budget is outlined for the second campaign in Table 2 and Table S3 for the first source measurement. Because these preliminary data failed to reduce the uncertainty of the ^{234}Th half-life, their incorporation would change the weighted average of 3 previously published measurements [11–13] and one previously recommended value [21] from the most recent evaluation [14] only marginally, from 24.10 ± 0.06 to 24.128 ± 0.052 days ($k = 2$). This is the weighted average calculated by limiting the weight of Knight and Macklin [11] to 50.0%, as they reported an order of magnitude smaller uncertainties than prior measurements. These uncertainties simply reflect counting statistics or deviation of data from the fit curve (whichever was larger), and thus could be underestimated if there were unnoticed systematic biases such as radioactive contaminants. Until higher precision measurements are achieved, the difference in $\lambda_{\text{U-238}}$ calculated using the $\lambda_{\text{Th-234}}$ value and uncertainty recommended by Luca [14] or the weighted average redetermined here is of little consequence, as shown in the next section.

Measurement of the ^{238}U decay constant

Table 3 shows experimental details pertaining to the six aliquots, and the resulting decay constants calculated from each. The extraction and purification chemistry for five of the aliquots was satisfactory, completed within 5 h with yields greater than 94%. However, the purification step for one of the middle aliquots (F , $t = 87.64 \pm 0.14$ days) was compromised due to a mislabeled reagent and had to be repeated such that the total elapsed time was 27 h. The result was a clear outlier that was discarded based on the known problems with the chemistry.

The uncertainty budgets for the individual aliquots are slightly variable (see Figure S3, supplemental information), as sensitivities to each parameter vary with ingrowth time. For example, samples approaching secular equilibrium are more sensitive to the accuracy of $\lambda_{\text{Th-234}}$ than those with shorter ingrowth times, but the shorter ingrowth samples have fewer atoms of ^{234}U to measure, which generally increases analytical uncertainty and blank sensitivity. Overall the largest contributors to the analytical uncertainty were uncertainty in $\lambda_{\text{Th-234}}$, uncertainty in the thorium extraction yield, and uncertainty in the final measurement of ^{234}U ingrown. The uncertainty in $\lambda_{\text{Th-234}}$ can only be improved with more and better measurements. The uncertainty in thorium yield was increased to $\sim 0.1\%$ ($k = 1$) by scatter among duplicate aliquots in the yield measurements that exceeded the analytical uncertainty. As the result is very sensitive to the accuracy of thorium yield, our next experiment will include efforts to improve precision in yield measurements. The final measurement of ingrown ^{234}Th as ^{234}U was analytically challenging because of the small amount of material being measured. If

Table 2 Summary of ^{234}Th half-life uncertainty budget from decay counting ^{234}Th source 2 (uncertainties in this table represent $k = 1$)

Process	Magnitude	Uncertainty ($k = 1$)	Uncertainty on $T_{1/2}$ ($k = 1$)
High frequency instability	Similar to Poisson statistics	0.82%	0.012%
Time	PC clock	< 0.002%	0.0009%
Ambient, on peak background	0.0024 CPS, 0.000023–0.0189%	0.082%	0.00012%
Counting uncertainties	0.224–2.03%	0.82%	0.012%
Medium-frequency instability	See residual structure	0.375%	0.169%
Impurities	None detected	< 0.001%	$1.5 \times 10^{-5}\%$
Dead-time	@ T_0 1.18% @T 0.56% Diff 0.62%	0.04%	0.019%
Source degradation	None observed	< 0.005%	0.0023%
Long-term instability	0.14% drift in ^{241}Am activity	0.07%	0.031%
Source position instability	None detected, guess 0.005%	0.005%	0.0023%
Total	24.17 ± 0.04 days		0.174%

Table 3 Summary of ^{238}U measured values for each aliquot in the daughter ingrowth experiment, and the calculated decay constant for each using the previously evaluated literature $\lambda_{\text{Th-234}}$

Aliquot	Atoms ^{238}U	Atoms ^{234}Th at t_0	Ingrowth time (d)	Thorium extraction yield (%)	^{234}Th atoms ingrown	$\lambda_{\text{U}238} \text{ s}^{-1}$
A	$1.7094 (42) \times 10^{22}$	$2.357 (12) \times 10^{10}$	44.447 (32)	97.37 (14)	$1.8837 (34) \times 10^{11}$	$4.907 (20) \times 10^{-18}$
B	$1.5164 (48) \times 10^{22}$	$1.7493 (96) \times 10^{10}$	67.977 (82)	98.26 (14)	$1.9469 (54) \times 10^{11}$	$4.910 (17) \times 10^{-18}$
<i>F</i>	<i>$1.4091 (22) \times 10^{22}$</i>	<i>$1.1545 (54) \times 10^{10}$</i>	<i>87.64 (14)</i>	<i>96.22 (14)</i>	<i>$1.8369 (46) \times 10^{11}$</i>	<i>$4.830 (16) \times 10^{-18}$</i>
D	$1.3706 (12) \times 10^{22}$	$1.5494 (86) \times 10^{10}$	108.06 (30)	98.29 (22)	$1.9519 (54) \times 10^{11}$	$4.953 (18) \times 10^{-18}$
E	$1.1167 (19) \times 10^{22}$	$3.157 (14) \times 10^{10}$	127.04 (56)	94.54 (64)	$1.6120 (38) \times 10^{11}$	$4.944 (17) \times 10^{-18}$
C	$1.42375 (17) \times 10^{22}$	$4.251 (22) \times 10^{10}$	131.99 (56)	99.17 (15)	$2.0734 (40) \times 10^{11}$	$4.954 (16) \times 10^{-18}$

Values in parentheses represent uncertainties with $k=2$

Aliquot F (italicized) was rejected from the data set

the experiment were performed with typical depleted uranium, the ^{234}U carry-over from the mother solution would have constituted an unacceptably large fraction of the total signal at $m=234$, at least 10%. In our experiment the correction to the signal at $m=234$ in each of the six aliquots ranged from 0.07 to 0.30 percent, and its uncertainty was estimated considering that the isotopic composition of uranium other than Q-metal that contributed to the blank is an unknown entity. If this component came from uranium with higher $^{234}\text{U}/^{235}\text{U}$ than those measured in laboratory blank measurements, then the data would be under-corrected for blank, thus overestimating the decay constant. Examining blanks and samples processed in the same laboratory space throughout the experimental campaign presented no evidence of this. Still, the uncertainty on the laboratory blank correction was estimated by varying the composition of the secondary component in the mixing line from depleted to enriched uranium and examining the standard deviation in the resulting $^{234}\text{U}/^{238}\text{U}$ values used in the correction. Because the carry-over was dominated by Q-metal, the sensitivity to the unknown component is small, and the laboratory blank uncertainty did not constitute more than 12.5% of the combined standard uncertainty on the isotope dilution measurement of ^{234}U ingrown into any aliquot (see Table S4).

The entire experiment is sensitive to the homogeneity of the solutions that are diluted and spiked to quantify uranium concentration and thorium yield. Significant effort before the experiment began went into optimizing the chemistry and ensuring homogeneity, but this is difficult to verify. The scatter among the triplicate dilutions of duplicate aliquots of the mother uranium solution exceeded the analytical uncertainty on any of the measurements. The scatter may reflect unknown variability in the dilution process, spiking and mass spectrometry used to measure the concentration. The large dilution factor necessary to reasonably spike the mother solution with IRMM-3636 required two dilution steps, and any error in the first step would be amplified.

Each aliquot was completely consumed to make the first dilution in duplicate, so more replicates could only be prepared for the second dilution. The stochastic weighing uncertainty is propagated into the analytical uncertainties and checks with calibration weights suggest that systematic weighing error is small (less than 0.005%). The uncertainty in quantifying thorium yield for the first extraction was propagated into the uncertainty of $N_{234}(0)$, and that from the second extraction into the uncertainty of $N_{234}(t)$. These are correlated by use of the same ^{229}Th spike and are also sensitive to any solution heterogeneity.

Figure 3 shows the decay constant calculated from each aliquot using the current evaluated $\lambda_{\text{Th-234}}$ [14], where there appears to be a bimodal distribution in which $\lambda_{\text{U-238}}$ from aliquots with ingrowth times less than 68 days (A and B) were smaller than those from aliquots with ingrowth times greater than 108 days (C–E). The collective data do not reflect a trend that would be consistent with an inaccurate $\lambda_{\text{Th-234}}$, but $\lambda_{\text{Th-234}}$ could be one contributing factor. If the Knight and Macklin $\lambda_{\text{Th-234}}$ is accurate, then only $\lambda_{\text{U-238}}$

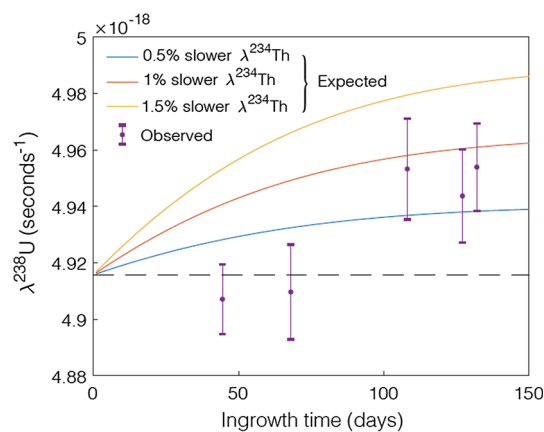

Fig. 3 $\lambda_{\text{U-238}}$ determined from each of the 5 ^{238}U aliquots A–E. Error bars represent $k=2$, and the dotted line shows the currently used value reported by Jaffey et al. [1]. Solid lines show where values would be expected to fall if $\lambda_{\text{Th-234}}$ were actually 0.5, 1 or 1.5% smaller than the currently used value recommended by Luca [14]

results from aliquots A and B are concordant with Jaffey et al. [1]. If the $\lambda_{\text{Th-234}}$ were approximately 0.5% smaller, aliquots C–E would be concordant with [1], however our preliminary $\lambda_{\text{Th-234}}$ result reported above is only 0.24% smaller, and only shifts the weighted average 0.12%. The bimodal distribution of results is concerning and could reflect an unknown systematic bias or larger than expected random errors. Possible reasons for the internal discordance are being considered, but the cause is currently unknown. Aliquots C–E all have a higher relative correction to the ingrowth time from the Monte Carlo calculation of the chemical separation. This makes sense because for samples with more thorium ingrown (approaching secular equilibrium) the decay of extracted thorium during purification steps should be more significant. We believe the ingrowth time correction is correct, and does not contribute to the bimodal distribution, which is still observed if nominal ingrowth times are used. The extractions ended at different times but were all spiked 5 months prior to the measurement. The time interval between thorium extraction and uranium ID-MS spiking ranged from 106 to 180 days, with A and B having the longest interval, thus a larger fraction of the ^{234}Th in A and B had decayed to ^{234}U at the time of spiking. If there were any slight differences in sorption or diffusion of uranium and thorium into the thick PFA vial bottom and walls before the aliquots were spiked with IRMM-3636, this could skew the ID-MS results. To mitigate this potential concern in the future, quartz vials will be used when a modified version of the experiment is repeated, and each thorium aliquot will be spiked with IRMM-3636 immediately after extraction. In the meantime, results from the five aliquots are averaged and the variance was added in quadrature to the uncertainty calculated by the Monte Carlo method, which includes all correlations. The overall uncertainty budget for the average is shown in Fig. 4 and is dominated by the between-aliquot variance contribution.

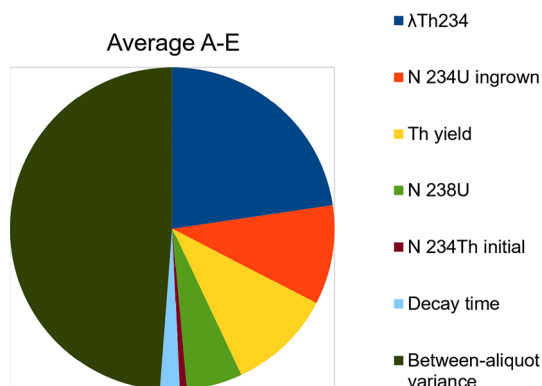

Fig. 4 Overall uncertainty budget for average $\lambda_{\text{U-238}}$ determined in thorium ingrowth experiment, using the evaluated literature $\lambda_{\text{Th-234}}$ [14]

The average results from the five aliquots A–E and using the evaluated literature $\lambda_{\text{Th-234}}$ [14] yielded the decay constant $4.934(30) \times 10^{-18} \text{ s}^{-1}$, 0.37% larger than that previously reported from α counting [1], with relative uncertainty of 0.613% ($k = 2$). If instead the new weighted average result for $\lambda_{\text{Th-234}}$ including this study is used, the resulting $\lambda_{\text{U-238}}$ is $4.929(23) \times 10^{-18} \text{ s}^{-1}$, 0.28% larger than [1], with relative uncertainty of 0.462% ($k = 2$). Figure 5 shows our preliminary result, converted to a half-lives of $4.452(27) \times 10^9$ or $4.456(21) \times 10^9$ years, respectively, along with previously reported and evaluated α -counting results (adapted from [5]). Of these, only our measurement, Kienberger [24] and Jaffey et al. [1] are not correlated with assumed natural uranium isotope ratios because they included measurements of enriched ^{238}U . Our results indicate slightly faster decay of ^{238}U than those obtained by medium-geometry α -counting but overlap with the evaluated ($k = 2$) uncertainty envelope [6] (shaded light blue in Fig. 5) and show consistency with the value determined via liquid scintillation counting by Steyn and Strelow [25]. Even though the desired precision has yet to be achieved, it is remarkable that this will be the first published measurement of this important quantity in nearly 50 years and was derived by methodology completely independent of those previously applied. These independent results underscore that values with very small relative uncertainties from a single study should be utilized with great caution, as systematic biases are plausible in both types of experiments. Results of our continued measurements (both $\lambda_{\text{U-238}}$ and $\lambda_{\text{Th-234}}$), should provide clarity on

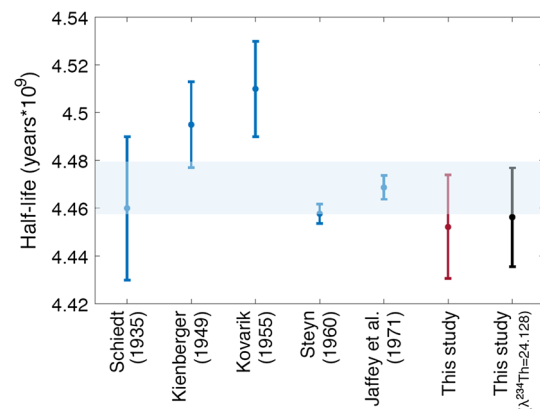

Fig. 5 Uranium-238 half-life determined in the present study using the currently evaluated $\lambda_{234\text{Th}}$ (red) or a new weighted average $\lambda_{234\text{Th}}$ (black) alongside previously reported values from α -counting experiments (blue), with the first author and year listed, adapted from (Schön et al. 2003). Of these, only our measurement, Kienberger 1949, and Jaffey 1971 were direct measurements of enriched ^{238}U , the rest are correlated with assumed natural uranium isotope ratios. All vertical bars represent the stated uncertainty ($k = 2$), and the evaluated uncertainty ($k = 2$) envelope (from Villa et al. 2016) is shaded light blue

the issue of concordance or discordance with previous reports.

Conclusions

New measurements of $\lambda_{\text{Th-234}}$ and $\lambda_{\text{U-238}}$ were achieved respectively by decay counting and a novel ingrowth experiment using mass spectrometry. The measured value of $\lambda_{\text{Th-234}}$ was $3.321(10) \times 10^{-7} \text{ s}^{-1}$, corresponding to a half-life of 24.157 ± 0.073 days ($k=2$). This result agrees within uncertainty with the evaluated literature (24.10 ± 0.06 days [14]) but lacks the precision required to better inform $\lambda_{\text{U-238}}$ measurement via thorium ingrowth. The preliminary result of the latter experiment is $4.929(23) \times 10^{-18} \text{ s}^{-1}$, corresponding to a ^{238}U half-life of $4.456(21) \times 10^9$ years. This average of results obtained from 5 aliquots is 0.28% less than the ^{238}U half-life previously reported from α counting; but suffered from internal inconsistency that increased the relative uncertainty to 0.462% ($k=2$). Due to the importance of this value in the planetary sciences as well as for nuclear science and research, and the encouraging results thus far, we are actively working on repeating a modified version of the experiment. Future efforts will include experimentally constraining uncertainties on solution homogeneity and other influencing factors. With our new results we hope to stimulate efforts within and across different scientific communities to recalibrate and refine decay constants that are not restricted to the ^{238}U decay chain, with the aim of a more accurate reconstruction of events and processes within planetary sciences.

Acknowledgements This document, LLNL-JRNL-752487, was prepared by LLNL under Contract DE-AC52-07NA27344. The authors thank Dave Ruddle of LLNL for engineering support, and T. Mark Harrison of the University of California, Los Angeles for his early support in advocating the needs of geochronology. This work was supported by LLNL's laboratory directed research and development (LDRD) program (16-LW-053). TPD also gratefully acknowledges support from the US Department of Homeland Security National Technical Nuclear Forensics Center post-doctoral fellowship.

References

- Jaffey AH, Flynn KF, Glendenin LE, Bentley WC, Essling AM (1971) Precision measurement of half-lives and specific activities of ^{235}U and ^{238}U . *Phys Rev C* 4(5):1889–1906
- Harrison TM, Baldwin SL, Caffee M, Gehrels GE, Schoene B, Shuster DL, Singer BS (2015) It's about time: opportunities and challenges for U.S. Geological Survey. Institute of Geophysics and Planetary Physics Publication 6539, University of California, Los Angeles
- Ludwig KR (2003) Mathematical-statistical treatment of data and errors for $^{230}\text{Th}/\text{U}$ $^{234}\text{Th}/\text{U}$ ^{238}U geochronology. *Rev Miner Geochem* 52(1):631–656
- Schoene B, Crowley JL, Condon DJ, Schmitz MD, Bowring SA (2006) Reassessing the uranium decay constants for geochronology using ID-TIMS U-Pb data. *Geochim Cosmochim Acta* 70:426–445
- Schön R, Winkler G, Kutschera W (2004) A critical review of experimental data for the half-lives of the uranium isotopes ^{238}U and ^{235}U . *Appl Radiat Isot* 60:263–273
- Villa IM, Bonardi ML, De Bièvre P, Holden NE, Renne PR (2016) IUPAC-IUGS status report on half-lives of ^{238}U , ^{235}U , and ^{234}U . *Geochim Cosmochim Acta* 172:387–392
- Ludwig KR (2000) Decay constant errors in U-Pb Concordia-intercept ages. *Chem Geol* 166:315–318
- Renne PR, Mundil R, Balco G, Min K, Ludwig KR (2010) Joint determination of ^{40}K decay constants and $^{40}\text{Ar}/^{40}\text{K}$ for the Fish Canyon sanidine standard, and improved accuracy for $^{40}\text{Ar}/^{39}\text{Ar}$ geochronology. *Geochim Cosmochim Acta* 74(18):5349–5367
- Holden N (1981) The uranium half-lives: a critical review. Information Analysis Center Report, National Nuclear Data Center, Brookhaven National Laboratory, Upton, NY. BNL-NCS-51320
- Holden N (1989) Total and spontaneous fission half-lives for uranium, plutonium, americium, and curium nuclides. *Pure Appl Chem* 61(8):1483–1504
- Knight GB, Macklin RL (1948) Half-life of UX_1 (^{234}Th). *Phys Rev* 74:1540–1541
- Kirsch G (1920) *Mitt. Ra. Inst. 127 Wien. Ber.* 11a, 129, 309, M-Sch.: 377
- Sargent BW (1939) *Can J Res A* 369:527–533
- Luca A (2010) Evaluation of ^{234}Th nuclear decay data. *Appl Radiat Isot* 68:1591–1594
- Verbruggen A, Alonso A, Eykens R, Kehoe F, Kühn H, Richter S, Aregbe Y (2008) Preparation and Certification of IRMM-3636, IRMM-3636a, and IRMM-3636b, JRC technical report 45903, EUR 23408 EN, ISSN 1018-5593. European Communities, Belgium
- Certificate of Analysis for NIST SRM 4342A. <https://www-s.nist.gov/srmors/certificates/4342A.pdf>
- Certificate of Analysis for New Brunswick Laboratories U010. https://science.energy.gov/~media/nbl/pdf/price-lists/certificates/CRM_U010_5_Milligram_Sample_Size_March_2008.pdf
- Bateman H (1910) The solution of a system of differential equations occurring in the theory of radioactive transformations. In: *Proceedings of the Cambridge Philosophical Society* 15(V): 423–427. https://archive.org/details/cbarchive_122715_solutionofasystemofdifferential1843
- Metropolis N, Ulam S (1949) The Monte Carlo method. *J Am Stat Assoc* 44(247):335–341
- Parker W, Bildstein H, Getoff N (1964) Molecular plating I, a rapid and quantitative method for the electrodeposition of thorium and uranium. *Nucl Inst Methods* 26:55–60
- Curie M, Debierne A, Eve AS, Geiger H, Hahn O, Lind SC, Meyer St, Rutherford E, Schweidler E (1931) The radioactive constants as of 1930. *Rev Mod Phys* 3:427–445
- Pommé S, Camps J, Van Ammel R, Paepen J (2008) Protocol for uncertainty assessment of half-lives. *J Radioanal Nucl Chem* 276(2):335–339
- Pommé S (2015) The uncertainty of the half-life. *Metrologia* 52:S51–S65
- Kienberger CA (1949) The uranium-234 content of natural uranium and the specific α -activities of the isotopes. *Phys Rev* 76(11):1561
- Steyn J, Strelow FWE (1960) The determination of the half-life of ^{238}U , absolute counting of α particles in a 4π -liquid scintillation counter. In: Sanielevici A (Ed) *Metrology of radionuclides*. IAEA STI/PUB/6, Vienna, Austria, pp 155–161