

# Effects of external electric field on microstructure and property of friction welded joint between copper and stainless steel

L. FU\*, S. G. DU

College of Materials Science, Northwestern Polytechnical University, Xi'an 710072, People's Republic of China

E-mail: fudi317@yahoo.com.cn

Published online: 15 May 2006

Formability is a key factor which influences the friction weldability of dissimilar materials. Resistance to formability of metals can be reduced by the electric induced plasticity under an external electric field. Friction welding of T2 Copper and 1Cr18Ni9Ti stainless steel was carried out under the electric fields with an attempt to improve the friction weldability of these two materials. Effects of different types of external electric field on the microstructure of the welded joints were investigated and distributions of the dominating elements in the weld zone were analyzed using EDX. Torsion strength of the joints obtained from different welding parameters was tested. It was indicated that the dynamic recrystallization of the weld metal was enhanced by the applying electric fields. For the specimen connected to the cathode of the power supply (referring to negative field), much homogenous distribution of the recrystallized grains in the weld zone appeared. The diffusion distance of the dominating elements increased under either an AC electric field or a negative field. The torsion strength of the welding joints was improved with applying the external electric field, especially with the AC electric field.

© 2006 Springer Science + Business Media, Inc.

## 1. Introduction

Copper has been widely used in the electrical industry owing to its high electrical conductivity and stainless steel is usually used as structure materials because of its high strength and corrosion resistance. It is usually more difficult to join copper and stainless steel by traditional friction welding because of the large difference in their physical properties, which can lead to high stress-strain field in the welding joint.

It is generally believed that metal under the electroplastic state is characterized by low flow stress, high deformation ability and high diffusion ability of atoms [1–4], because the electric field enhances the mobility of lattice defects, and leads to the microstructure rearrangement. Some research works indicated that DC pulse electric current increased the recovery rate and recrystallization rate of copper during an isothermal anneal process. This led to a decrease in the size of recrystallized grains, as well as the grain growth speed and the formation of twinned grains [5]. Work by Conrad and coworkers demonstrated the influence of high voltage electric field on the

recovery and recrystallization process of copper and aluminum [6]. They found that the recovery and recrystallization temperatures of copper and aluminum were increased by the use of an electric field. Results obtained for other materials include, for example, an external electric field restrained the recrystallization process of steel plate in cold-rolling state, and improved the formation and development of the fiber recrystallization structure [7]. Earlier works published elsewhere showed that the equiaxial recrystallized grains in dynamic recrystallization zone (DRZ) of the friction welded joint of aluminum increased and microstructure became more homogeneous along the axial direction in the weld zone when applying an external electric field. Furthermore, the external electric field increased the width of the DRZ, and led to the increasing hardness of the welded joint and the homogeneous hardness distribution [8, 9].

Deformation of the material during friction welding is generally achieved by a so-called diffusion mechanism involving the migration of lattice defects (vacancies or dislocations), which can be affected by an external

\*Author to whom all correspondence should be addressed.

TABLE I Chemical composition of the materials used in the friction welding process (Unit: wt.%)

Materials	Chemical composition							
	C	Cr	Fe	Ni	Ti	Si	Cu	O
Copper	/	/	0.005	0.006	/	/	99.9	0.006
Stainless steel	0.095	17.26	Balance	8.52	0.4	0.83	/	/

electric field [6, 7]. In the view of this, it is anticipated that an external electric field may have some favorable effects on the diffusion behaviors during the friction welding process of dissimilar materials, which could have practical importance as well as scientific interest. In this research, an external electric field was applied to the friction welding of copper T2 and stainless steel 1Cr18Ni9Ti. The dynamic recrystallization and the related microstructure of the recrystallized grains in the weld zone were investigated. The distribution of the dominating elements in the weld zone was determined by means of EDX analysis and the mechanical properties of the welding joints were evaluated by torsion tests.

## 2. Experimental procedures

The parent materials used for experiment were copper T2 and stainless steel 1Cr18Ni9Ti of 30 mm in diameter in hot-rolled state. The chemical compositions of the parent materials are given in Table I.

The welding trials were carried out on a continuous driving friction welding machine (model C25), attached with an electric field producing apparatus, as shown in Fig. 1. In this Figure, o refers to the center of the circle on the welding surface; r the radial distance from point o, z the vertical distance from the welding line. Welding parameters, such as pressure, rotation speed, torque and axial burn-off length, were monitored and controlled in real time during the welding process. In the welding process, the specimen installed in the fixed fixture of the friction machine was connected to one of the electrodes

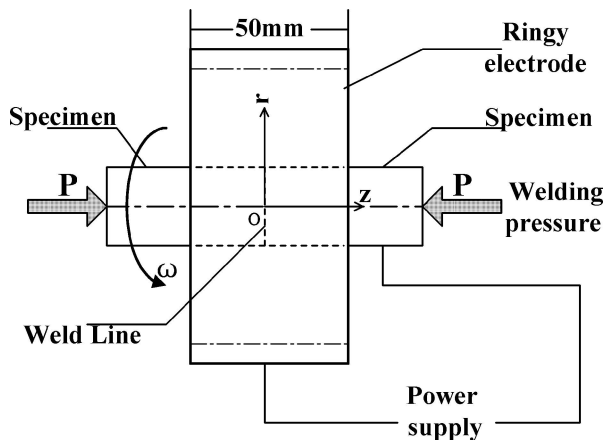

Figure 1 Schematic diagram of the experimental arrangement used in the welding process.

of a high voltage power supply (model GYY-1) that can apply constant voltage ( $V = 5 \text{ kV}$ ), and a copper ring covered the specimens was linked to the other electrode. The air gap between the ring and the specimen was 10 mm. The intensity of electric field acted on the specimens was calculated to be  $6.5 \text{ kV cm}^{-1}$ . The main welding parameters used in the experiments are given in Table II. A constant rotational speed was kept at  $1450 \text{ r min}^{-1}$  and the maximum temperature on the welding surface was approximately  $1000^\circ\text{C}$ . Three types of connection between the specimen and the power supply were employed to investigate the effects of the electric field type. Negative, positive and AC electric field were denoted to the states that the specimen was connected to the cathode, anode of DC supply and AC power supply, respectively. The frequency of the AC electric field was 50 Hz. Welding without any electric field was also performed for comparison. Six specimens were welded using each set of welding parameters.

The microstructure observation was performed by a Newphoto-IIoptical microscopy. The mean linear intercept method was employed to detect the average grain size. The number of grains considered ranged from 50 to 100 and the experimental error was  $0.1 \mu\text{m}$ . Distribution of the dominating elements along the welded joints was analyzed by an EPM-810 electron probe microscopy. The torsion strength of the welded joint was measured with a BALFRED J. AMSLER torsion test machine.

## 3. Experimental results

Fig. 2 shows the microstructure of the copper side in the traditional friction welded joint between copper T2 and stainless steel 1Cr18Ni9Ti. During the friction welding, deformation and recrystallization of the material mainly occurred in the weld zone near copper because of its lower elevated temperature strength, and were hardly recognized near stainless steel. The interface between copper T2 and stainless steel 1Cr18Ni9Ti was uneven because of adhering, shearing and stirring behaviors during the friction welding process.

As shown in Fig. 2, the microstructure of dynamic recrystallization zone of copper was composed mainly of equiaxial  $\alpha$  copper grains, with some twinborn grains and little  $\text{Cu}_2\text{O}$  impurity [10]. Partial dynamic recrystallization zone was characterized by large grain size as well as heterogeneous distribution, comparing to full dynamic recrystallization zone. Some significantly deformed grains were still remained in the partial dynamic recrystallization zone near parent metal.

TABLE II The electric field and the friction welding parameters

Condition no	Friction pressure $P_1$ (MPa)	Forging pressure $P_2$ (MPa)	Friction time $t_1$ (s)	Forging time $t_2$ (s)	Intensity of electrical field $E$ ( $\text{kV cm}^{-1}$ )	Type of the electric field
1	1.0	1.4	2	6	0	No field
2	1.0	1.4	2	6	6.5	Positive
3	1.0	1.4	2	6	6.5	Negative
4	1.0	1.4	2	6	6.5	AC (Frequency $f = 50$ Hz)

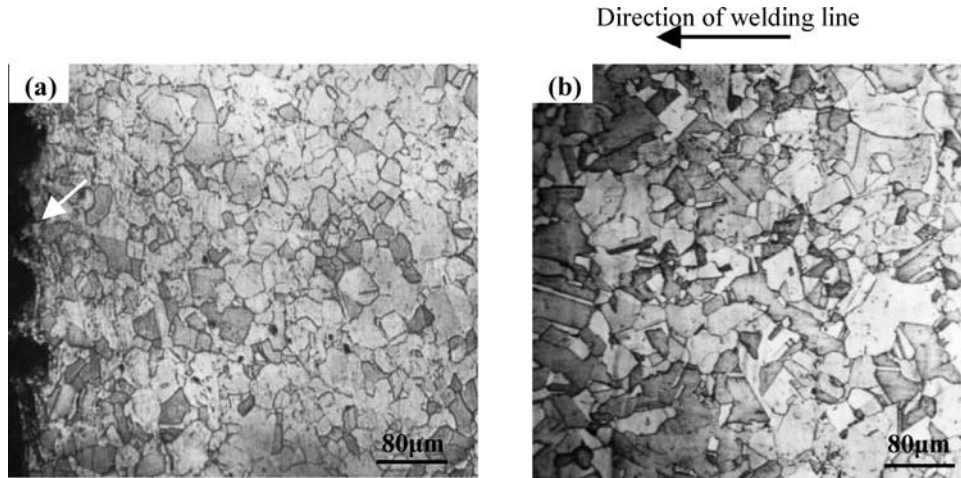

Figure 2 Microstructure of copper in the friction welding joint between copper and stainless steel obtained without electric field (the welding line is marked by an arrow): (a) Full dynamic recrystallization zone ( $r = 0$  mm,  $z = 0$  mm); (b) Partial dynamic recrystallization zone ( $r = 0$  mm,  $z = 1$  mm).

Fig. 3 shows the microstructure of copper in a typical welded joint between copper T2 and stainless steel 1Cr18Ni9Ti under different electric fields. It is clear that the recrystallization process in the weld zone of copper was enhanced and the grain size in the recrystallization zone of copper became homogenous, in comparison to that obtained by traditional friction welding (Fig. 2). Table III gives average grain size ( $d$ ) and width ( $B$ ) of the recrystallization zone of copper under different electric fields. The average grain size for the sample obtained under a negative electrostatic field was larger than that in a normal friction welding process, as shown in Table III. On the contrary, the average grain size of copper in recrystallization zone obtained under an AC electric field was slightly smaller than that without an external electric field. However, there is almost no obvious influence on the recrystallized grain size under a positive electrostatic field.

From the Figs 2 and 3, the smooth grain boundary and homogenous grain size distribution could be obviously observed in the friction weld zone near copper under a negative electrostatic field, due to the dynamic recovery, recrystallization and then growth of the grains. However, the grains went through the recrystallization without growth under an AC electric field. Therefore, the boundary of most grains showed more straight line and the grain size distribution appeared heterogeneous when applying the AC electric field, while only few of grains boundary still remained straight under a positive electrostatic field.

Fig. 4 illustrates the distribution of the dominating elements along the friction welding joints between copper and stainless steel under different kinds of external electric field. As shown in the Fig. 4, the concentration of elements Fe and Cr increased, and that of element Cu decreased from copper to stainless steel in the weld zone. This indicated that a diffusion layer existed in the friction weld zone. Table IV lists the diffusion width of the dominating elements in the weld zone under different electric fields. It is clear from Table IV that the width of the diffusion layer depended on the type of external electric field, as well as the location in the joints. At the same detecting radius, the diffusion distance of the dominating elements in the friction welded joints increased when an external electric field was applied. The diffusion distance of the dominating elements was obviously enhanced by an AC electric field, while the diffusion widths changed a little under a positive electrostatic field.

Table V gives the torsion property of the friction weld joints between copper and stainless steel under different external electric fields. It is clear that the torsion strengths were higher than that of copper when applying an external electric field. The highest torsion strength of the friction welded joints was achieved when an AC electric field was applied. Actually, the effect of the external electric field on the torsion strength of the welded joint reflected the integrated influence of the electric field on the size and its distribution of the recrystallized grains, and the diffusion distance of the dominating elements in the weld zone.

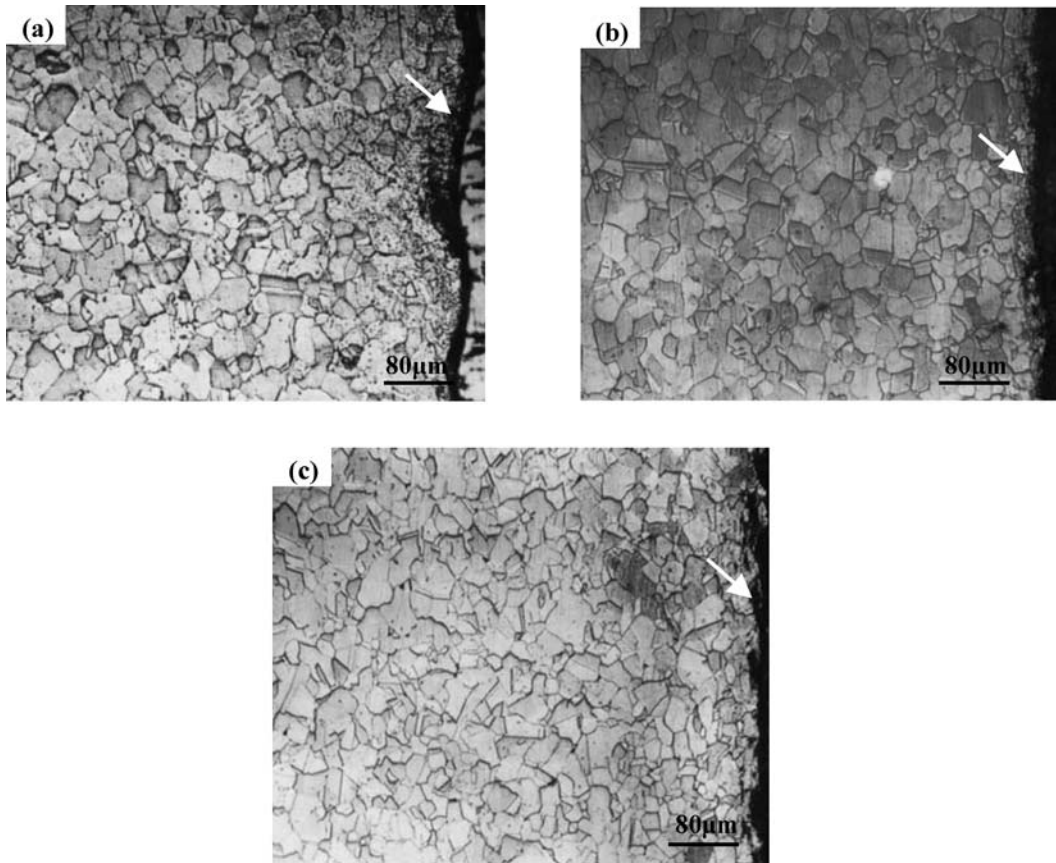

Figure 3 Microstructure of copper in the friction welding joint between copper and stainless steel obtained under different electric fields (the welding line is marked by an arrow,  $r = 0$  mm,  $z = 0$  mm): (a) Positive; (b) Negative; (c) AC.

#### 4. Discussions

It is well known that plastic deformation brings defects, such as dislocations, vacancies and grain boundaries, into the crystal lattices of grains during friction welding process. These defects are thermodynamically unstable in deformed weld zone, and can be transferred into a stable state through thermal dynamic recovery and recrystallization processes near and in the weld zone of the friction welded joint.

It is apparent that an applied electric field had some influence on nucleus formation and growth of the recrystallized grains in the friction weld zone near copper. The electrostatic field, especially the negative field, enhanced the dynamic recovery and recrystallization processes of the grains, which led to homogenous distribution of grains size [4]. AC electric fields may reduce the energy required for the grain recrystallization in the friction weld zone near copper and increase the degree of the plastic deformation

in these areas. At the same time, AC electric fields also increased the diffusivity of elements. Because of these combined influences on the recrystallization process, the size of the recrystallized grains in the friction weld zone near copper decreased slightly by using the AC electric field as shown in the Fig. 3.

Different types of the external electric field have different mechanisms pertaining to the deformation and the recrystallization processes of the friction welding between copper and stainless steel. External electric field can be treated as a kind of energy and primarily change the kinetic energy, potential energy and their distribution of a whole welding system [11, 12]. On the other hand, the external electric field also introduces electrons into a closed friction welding system. In traditional friction welding process, the weld zone can be regarded as an isolated system with electrons, the number of which is invariable. When applying an electrostatic field to the friction weld, the quantity of electrons and its distribution in the weld zone will be changed. It was found that the electrostatic field decreased the density of the charged electrons and the energy of fermions, and also reduced the electrons' interaction in the materials [11]. That is to say, the electrostatic field can decrease the internal energy of the friction weld zone, while the AC electric field mainly changes the kinetic energy of the electron system in the friction weld metal by the electromagnetic effects and then affected

TABLE III Average recrystallized grain size ( $d$ ) and width ( $B$ ) of the recrystallization zone of copper under different electric fields

Condition	No field	Positive	Negative	AC
Grain size $d$ ( $\mu\text{m}$ )	23.1	24.2	27.4	20.3
Width of recrystallized zone $B$ ( $\mu\text{m}$ )	848.2	910.3	962.1	936.4



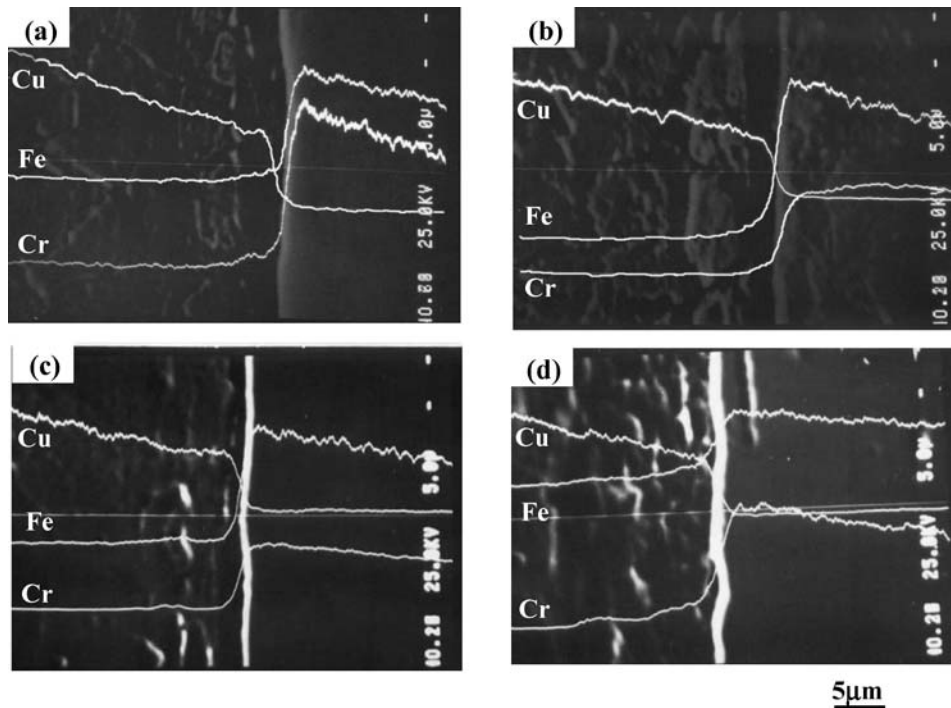

Figure 4 Electronic probe test results in the weld zone of the friction welding joints with and without electric field ( $r = 13$  mm,  $z = 0$  mm): (a) No field; (b) Positive; (c) Negative; (d) AC.

the diffusion behavior of the atoms in the friction weld zone.

It is also suggested in the previous research works, that the applied static electric field could enhance the diffusion process, and significantly increase the ability of grain boundary sliding accompanied by the diffusion process, when the specimens are connected to the anode of the electric power [2, 6, 13]. Owing to the effect of the positive electrostatic field on the lattice defects (vacancies or dislocations), defects could be charged. The applied electric field lead to not only the charged surface layer on metallic materials, but also the interaction of the surface charge with charged defects, particularly the vacancies. When the charged defects approached the specimen surface, an additional defect flux was created, which in turn enhanced the dislocation climb and grain formation and coalescence. This could accelerate the nucleation and

growth of dynamically recrystallized grains. Therefore, the external electrostatic field will improve slipping and climbing of the dislocations related to the plastic deformation in the weld zone of the friction welded joint. Further studies are still needed for the mechanism of the effect of the negative electrostatic field on the recrystallization process of friction weld zone.

## 5. Conclusions

1. The dynamic recrystallization process in the weld zone of the friction welded joint between copper and stainless steel was enhanced by an electrostatic field. A larger recrystallized grain size of copper, as well as its homogenous distribution was obtained under a negative electrostatic field. On the other hand, the grain size was slightly smaller under an AC electric field than that without an external electric field. There is almost no obvious influence on the recrystallized grain size under a positive electrostatic field.

2. The diffusion width of the dominating elements in the friction welding joints between copper and stainless steel increased when an external electric field was applied. An AC electric field gave more obviously enhanced diffusion widths of the dominating elements, compared to the effect from a DC electric field.

3. Torsion strengths of the welded joint were higher than that of the parent metal copper when an external electric field was applied. The highest torsion strength was achieved when an AC electric field was applied, due to the integrated influence of the AC electric field on the size and distribution of the recrystallized grains and the diffusion distance of the dominating elements in the weld zone.

TABLE IV Diffusion width of the dominating elements in the weld zone under different electric fields (Unit:  $\mu\text{m}$ )

Condition	No field	Positive	Negative	AC
Fe	3.629	4.018	5.02	7.059
Cu	3.335	3.724	4.688	6.176
Cr	4.318	4.94	5.938	8.824

TABLE V Average torsion strength of the weld zone of the friction welding joints between copper and stainless steel

Condition No	1	2	3	4
Torsion strength $\tau_b$ (MPa)	220	287	305	319
Fracture location	Weld line	Weld line	Weld line near Cu side	Cu side

## Acknowledgments

This research was supported by the Aviation Science Foundation of China under grant No. 03H53035.

## References

1. J. CAMPBELL, Y. FAHMY and H. CONRAD, *Metallurg. Mater. Trans. A* **30A** (1999) 2817.
2. W. LIU, K. M. LIANG and Y. K. ZHENG, *J. Mater. Sci.* **33** (1998) 1043.
3. G. Y. TANG, J. ZHANG and M. X. ZHENG, *Mater. Sci. Engng. A* **281** (2000) 263.
4. Y. V. BARANOV, *ibid. A* **287** (2000) 288.
5. H. CONRAD, N. KARAM and S. MANNAN, *Scripta Metallurgica* **18** (1984) 275.
6. H. CONRAD, Z. GUO and A. F. SPRECHER, *ibid.* **23** (1989) 821.
7. Y. N. WANG and C. S. HE *et al.*, *Steel* **36** (2001) 42.
8. L. FU and W. Q. JIE, *J. Mater. Sci.* **38** (2003) 1147.
9. L. FU, W. Q. JIE and S. G. DU, *Weld. Journal* **83** (2004) 232s.
10. S. G. DU, *Trans. Northwest. Polytechn. Univ.* **11** (1993) 63.
11. B. LIU and Z. CHEN, *J. China Rare Earth Soc.* **19** (2001) 58.
12. Z. CHEN and B. LIU, *Rare Metal Mater. Engng.* **30** (2001) 331.
13. H. A. LU and H. CONRAD, *Appl. Phys. Lett.* **59** (1991) 1847.

*Received 13 April  
and accepted 10 August 2005*