

Quantifying temporal variability in the metacommunity structure of stream fishes: the influence of non-native species and environmental drivers

T. Erős · P. Sály · P. Takács · C. L. Higgins ·
P. Bíró · D. Schmera

Received: 21 September 2012 / Revised: 20 July 2013 / Accepted: 24 August 2013 / Published online: 5 September 2013
© Springer Science+Business Media Dordrecht 2013

Abstract Most studies characterize metacommunities based on a single snapshot of the spatial structure, which may be inadequate for taxa with high migratory behavior (e.g., fish). Here, we applied elements of metacommunity structure to examine variations in the spatial distributions of stream fishes over time and to explore possible structuring mechanisms. Although the major environmental gradients influencing species distributions remained largely the same in time, the best-fit pattern of metacommunity structure varied according to sampling occasion and whether or not we

included non-native species in the analyses. Quasi-Clementsian and Clementsian structures were the predominant best-fit structures, indicating the importance of species turnover among sites and the existence of more or less discrete community boundaries. The environmental gradient most correlated with metacommunity structure was defined by altitude, area of artificial ponds in the catchment, and dissolved oxygen content. Our results suggest that the best-fit metacommunity structure of the native species can change in time in this catchment due to seasonal changes in distribution patterns. However, the distribution of non-native species throughout the landscape homogenizes the temporal variability in metacommunity structure of native species. Further studies are necessary from other regions to examine best-fit metacommunity structures of stream fishes within relatively short environmental gradients.

Electronic supplementary material The online version of this article (doi:10.1007/s10750-013-1673-8) contains supplementary material, which is available to authorized users.

Handling editor: David J. Hoeinghaus

T. Erős (✉) · P. Sály · P. Takács · P. Bíró · D. Schmera
Balaton Limnological Institute, MTA Centre for
Ecological Research, Klebelsberg K. u. 3, Tihany 8237,
Hungary
e-mail: eros.tibor@okologia.mta.hu

C. L. Higgins
Department of Biological Sciences, Tarleton State
University, Stephenville, TX, USA

D. Schmera
Section of Conservation Biology, University of Basel,
Basel, Switzerland

Keywords Metacommunities · Elements of metacommunity structure · Fish assemblages · Temporal variation · Non-native species · Homogenization

Introduction

The metacommunity concept substantially advanced ecological research by providing an opportunity to examine how local niche-based processes interact with regional dispersal-based processes to influence

patterns of community structure across the landscape (Leibold et al., 2004; Holyoak et al., 2005). At the regional level, species are often distributed along multiple environmental gradients, resulting in particular patterns of metacommunity structure (Presley et al., 2009). Clementsian distributions arise when groups of species show similar responses to environmental gradients and therefore can be classified into well-defined, distinctive community types (Clements, 1916). Gleasonian distributions reflect individualistic responses that yield a continuum of gradually changing composition without clumping (Gleason, 1926). Evenly spaced gradients can occur in systems with intense interspecific competition in which trade-offs in competitive ability result in spatial distributions with evenly dispersed populations (Tilman, 1982). Alternatively, intense competition may manifest as mutually exclusive spatial distributions, resulting in checkerboard patterns (Diamond, 1975). Metacommunities with nested structure are associated with predictable patterns of species loss in which species-poor communities are proper subsets of more speciose communities; the resulting pattern of species loss is based often on species-specific characteristics such as dispersal ability, habitat specialization, tolerance to abiotic conditions (Patterson & Atmar, 1986; Ulrich et al., 2012). Until recently, these models have been tested separately and, in many cases, even without determining whether the spatial distribution was significantly different than random (Leibold & Mikkelsen, 2002; Presley et al., 2010).

The elements of metacommunity structure (EMS) approach of Leibold & Mikkelsen (2002) is useful when trying to characterize the overall pattern of species distributions from a regional perspective (e.g., Clementsian, Gleasonian, nested distributions) by assessing aspects of coherence, species turnover, and boundary clumping. These components (Fig. 1, see “Materials and methods” section for more detail), coupled with the additions of Presley et al. (2010), identify patterns in the spatial distribution of multiple species across the region and allows for the exploration of relationships between species distributions and environmental gradients. Previous pattern identification methods mostly tested for the existence of a single spatial distribution (e.g., nested or checkerboard patterns), whereas the EMS approach of Leibold & Mikkelsen (2002) tests for multiple distributions simultaneously by discriminating among a set of

idealized patterns and their quasi-structures in a single set of analyses (Presley et al., 2010). Examining spatial and temporal patterns in how species are spatially distributed using EMS can be fruitful for our generalizations about the diversity and relative frequency of community patterns in nature, especially in regards to the effects of human perturbation (e.g., habitat modifications, climate change, introduction of non-native species). From an applied perspective, a comprehensive understanding of how species are spatially distributed and disperse within and among fragmented habitats (i.e., metacommunity structure), and how that structure changes through time is required to establish effective conservation policy. For example, a nested structure may permit the prioritization of just a small number of the richest sites, whereas a Clementsian or Gleasonian structure requires devoting conservation efforts to several different sites, not necessarily the richest ones (Baselga, 2010). The identification of idealized distribution patterns is also at the heart of applied stream ecology because management usually requires well-defined assemblage types for conservation purposes (Aarts & Nienhuis, 2003; Heino et al., 2003; Hermoso & Linke, 2012).

Freshwater assemblages (e.g., fish and macroinvertebrates) have been associated with a variety of non-random species distribution patterns (Jackson et al., 2001; Heino, 2011). Several studies examined whether they show discrete species assemblages or a continuum in individualistic species replacement along the longitudinal profile of streams and rivers (Matthews, 1998; Stutzner & Higgler, 2006; Lasne et al., 2007). Nested distribution patterns due to selective extinction and/or colonization events or changes in the diversity of habitats have also been identified along the longitudinal continuum (Taylor, 1997; Erős & Grossman, 2005). Although much is known about the spatial distribution of stream assemblages in regards to longitudinal zonation within a river (Aarts & Nienhuis, 2003; Ibarra et al., 2005; Stutzner & Higgler, 2006), few studies have investigated the spatial distribution in regards to a network of smaller streams and shorter environmental gradients (but see Heino, 2005 for a test on stream macroinvertebrates). Additionally, the lack of studies that focus on the temporal variability in metacommunity structure in stream systems is surprising given that streams are dynamic ecosystems both spatially and temporally (Resh et al.,

Fig. 1 A diagrammatic representation of how EMS can differentiate among six idealized patterns of metacommunity structure and their quasi-structures, adapted from Willig et al. (2011), and originally conceptualized in Leibold & Mikkelsen (2002) and Presley et al. (2010). Note that the *dark gray ovals* are the EMS and the *light gray* area highlights the “Quasi-” structures

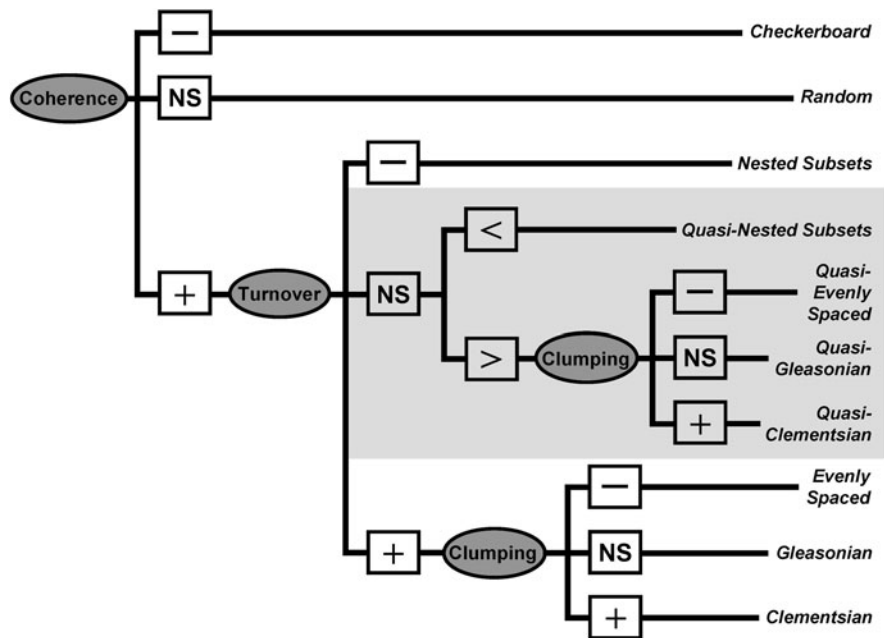

1988; Lake, 2000; Grossman et al., 2010). In terms of temporal, or seasonal variation, stream fish often migrate between feeding habitats, spawning grounds, and refugia (Schlosser, 1991). The potential movement of fish over time should alter local and regional patterns of diversity (i.e., metacommunity structure). Additionally, patterns of biodiversity are increasingly affected by the introduction of non-native species that can potentially impact communities by altering habitat, increasing predation pressure and/or interspecific competition (e.g., for food or shelter), and hybridizing with native species (Fridley et al., 2007). The impact of non-native species on spatial and temporal patterns of metacommunity structure, however, remains largely unknown.

The objective of this study was to examine temporal variability in metacommunity structure of stream fishes in the catchment of Lake Balaton, Hungary. First, we wanted to characterize fish species distributions across the landscape by determining best-fit metacommunity structures over time. Second, we wanted to disentangle the potential effects of non-native species on metacommunity structure by using only native species (and consequently excluding non-natives) in the same temporal EMS analyses. Third, we wanted to determine which environmental variables were most likely responsible for producing the observed metacommunity structure.

Materials and methods

Study area and stream surveys

We sampled a total of 40 sites across 22 wadable streams in the catchment of Lake Balaton, Hungary (5,775 km²) from Spring 2008 to Autumn 2010 (Fig. 2). A complete description of the study area can be found in the work of Sály et al. (2011), but will be reiterated here, briefly. The dominant land use type in the catchment is agricultural (mainly arable lands, vineyards, and orchards) and comprises about 40% of the total area. Deciduous forests (28%) as well as pastures and grasslands (12%) are the other characteristic land cover types. The proportion of stagnant water bodies, watercourses, and wetlands is in combination 14%, and that of the human inhabited area is 6%. The highland and lowland streams in the catchment provide heterogeneous environmental conditions for fish, ranging from well-shaded stream sections to more open, weed or macrophyte-dominated channels. The dominant substrates are typically gravel or silt-sand. Streams are usually less than 5 m wide, and they are fairly modified with dikes along the banks for controlling floods, especially in the most lowland sections. Ponds and small reservoirs (hereafter ponds) used for aquaculture, recreational fishing, and irrigation purposes can be also found in the catchment.

Fig. 2 A map of the studied stream network with the locations of the 40 sampling sites (*solid circles*) in the catchment area of Lake Balaton, Hungary

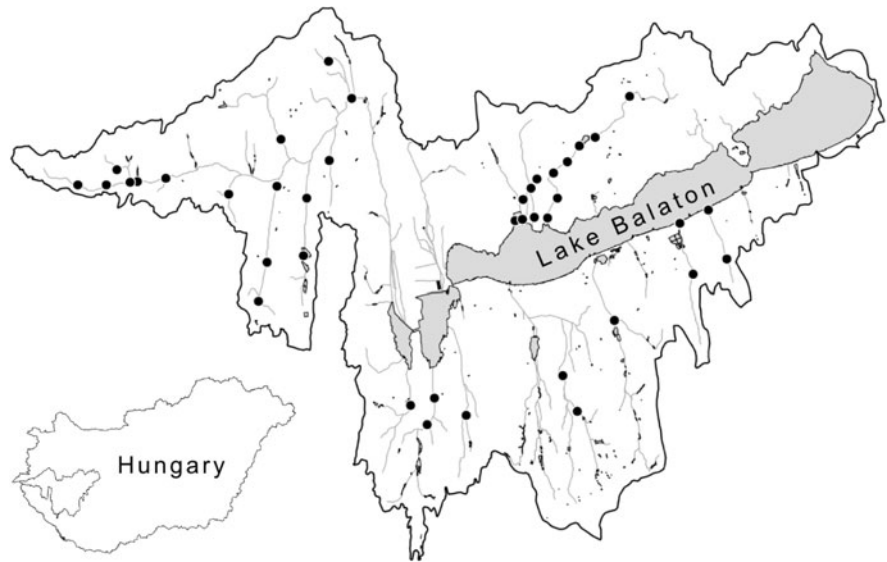

These artificial ponds are built on the streams and some of them maintain dense populations of non-native species, which may regularly escape into the streams, especially at high water levels, when the sluices are usually opened (see Erős et al., 2012).

Fish surveys

The 40 sites were surveyed three times in each year (spring, summer, and autumn) with a standardized sampling protocol, resulting in a total of 360 samples (40 sites \times 3 years \times 3 seasonal samples). The sampling sites were randomly selected from potential candidate sites, which were selected after preliminary investigation in 2006 and 2007 to be representative of longer stream sections (i.e., stretch with similar instream habitat features and riparian characteristics) based on land use and instream habitat characteristics, and accessibility constraints. At each site, we surveyed a 150 m long reach by wading, single pass electro-fishing using a backpack electrofisher (IG200/2B, PDC, 50–100 Hz, 350–650 V, max. 10 kW; Hans Grassl GmbH, Germany). This amount of sampling effort was found to yield representative samples of fish assemblages in this study area for between-site assemblage comparisons (Sály et al., 2009) and is also comparable with those routinely used elsewhere for the sampling of fish in wadeable streams (Magalhães et al., 2002; Schmutz et al., 2007; Hughes & Peck, 2008). Fish were stored in aerated containers

filled with water while fishing, then identified to species level, counted, and released back to the stream.

Environmental variables

We measured a number of local environmental and landscape-level variables (Appendix I in Electronic Supplementary Material) that have been shown to structure fish assemblages in this catchment (Sály et al., 2011) and elsewhere (e.g., Wang et al., 2003; Hoeinghaus et al., 2007). At each sampling site, 6–15 transects (depending on the complexity of the habitat) were placed perpendicular to the main channel of the stream to characterize physical features of the environment. Wetted width was measured once along each transect, whereas water depth and current velocity (at 60% depth) were measured at 3–6 (varied according to the width) equally spaced points along each transect. Visual estimates of percentage substratum cover were made at every transect point as well (see Appendix I in Electronic Supplementary Material for categories). Percentage substratum data of the transect points were later pooled and overall percentage of substrate categories were calculated for each site. Conductivity, dissolved oxygen content, and pH were measured with an OAKTON Waterproof PCD 650 portable handheld meter before fish sampling, and the content of nitrogen forms (i.e., nitrite, nitrate, ammonium) and phosphate were measured using field kits (Visicolor ECO, Macherey-Nagel GmbH & Co. KG., Germany).

Coefficient of variation (CV) of depth, velocity, and width data were also calculated to characterize temporal variability in flow regime. Land cover variables were quantified based on their proportion (%) in the catchment area above each sampling site. Digital land cover information was obtained from the CORINE Land Cover 2000 database (CLC2000; European Environmental Agency, <http://www.eea.europa.eu>) (see Appendix I in Electronic Supplementary Material). We quantified the variable “pond area” as the total area of ponds located within the upstream catchment of each sample site. The longitudinal position of each sample site was measured as the stream-line distance from each site to its upstream source and to the downstream mouth of the stream at a scale of 1:80,000 using the National GIS Database of Hungary (Institute of Geodesy, Cartography and Remote Sensing, Hungary). The variables altitude, stream-line distances, and land cover descriptors were measured only once, whereas instream physical and chemical variables were measured during each sampling occasion.

Data analysis

Following Leibold & Mikkelsen (2002) and Presley et al. (2010), we analyzed aspects of coherence, species turnover, and boundary clumping (EMS analysis) to characterize the seasonal metacommunity structure of stream fish assemblages over time. We used reciprocal averaging (also called correspondence analysis, CoA), an unconstrained ordination method, to arrange the sampling sites so that sites with similar species composition are adjacent and to arrange the order of species so that species with similar spatial distributional range (i.e., spatial occurrence patterns) are closer together. One of the advantages of using this ordination technique is that one does not have to a priori specify which environmental variables to include because the first axis is based on maximum association between site scores and species scores (Leibold & Mikkelsen, 2002). That is, the primary axis represents the strongest relationship between species composition within a site and spatial distribution of species among sites. Thus, any environmental variables significantly correlated with that primary axis of variation, or latent environmental gradient, would likely be an important factor in determining a species' distributional pattern.

After rearranging the data matrix, we tested for coherence in species occurrences along the compositional gradient defined by the first ordination axis (CoA1). We counted the number of embedded absences (gaps in species distributions) and compared that number to a null distribution created from a null model with 1,000 iterations. The null model constrained simulated species richness of each site to equal empirical richness, with equiprobable occurrences for each species (Presley et al., 2010). If the number of embedded absences was significantly different from random with more embedded absences than that expected by chance, we considered coherence to be negative. This suggests that trade-offs in competitive ability between species may manifest as a “checkerboard” like spatial distribution (Diamond, 1975). If the number of embedded absences was significantly less than that expected by chance, we considered the coherence within the metacommunity to be positive. Positive coherence indicates that a majority of the species are responding similarly to a latent environmental gradient defined by the primary axis of variation (Leibold & Mikkelsen, 2002).

For metacommunities that were positively coherent, an additional aspect (species turnover) was considered. Species turnover was measured as the number of times one species replaced another between two sites (i.e., number of replacements) for each possible pair of species and for each possible pair of sites. A replacement between two species (e.g., species A and B) occurs when the range of species A extends beyond that of species B at one end of the gradient and the range of B extends beyond that of A at the other end of the gradient. The observed number of replacements in a metacommunity is compared to a null distribution that randomly shifts entire ranges of species (Leibold & Mikkelsen, 2002). Significantly low (negative) turnover is consistent with nested distributions, and significantly high (positive) turnover is consistent with Gleasonian, Clementsian, or evenly spaced distributions, requiring further analysis of boundary clumping to distinguish among them. Boundary clumping quantifies the geographic distribution of all species, determining whether the metacommunity is clumped, evenly spaced, or random with respect to the spatial distribution of species across the region (Leibold & Mikkelsen, 2002). We quantified the degree of boundary clumping using Morisita's index, which is typically viewed as a statistical

measure of dispersion of individuals in a population (Morisita, 1971). However, this index can be extrapolated to include the dispersion of species in a metacommunity (Leibold & Mikkelsen, 2002). Index values significantly greater than 1 indicated substantial boundary clumping (i.e., Clementsian distribution), values significantly less than 1 indicated evenly spaced boundaries, and values not significantly different from 1 indicated randomly distributed species boundaries (i.e., Gleasonian distribution).

We performed the EMS analysis for each seasonal survey separately (i.e., nine occasions). We conducted the analyses at the entire assemblage (which included both native and non-native species) and the native assemblage (containing only native species) levels for each seasonal dataset. This resulted in a total of 18 EMS analyses (9 occasions \times 2 assemblage levels). Rare species (i.e., species representing $<0.1\%$ relative abundance and/or species that occurred only at one site) were removed prior to analyses to reduce their disproportional effect on the results (Legendre & Legendre, 1998; Presley et al., 2009; Keith et al., 2011). Analyses of coherence, species turnover, and boundary clumping (i.e., EMS) were conducted with algorithms written in Matlab 7.5 (Presley et al., 2010; available at <http://faculty.tarleton.edu/higgins/metacommunity-structure.html>).

Modeling metacommunity structure with environmental data

We used multiple linear regression to assess the importance of environmental variables in influencing metacommunity structure, with the first corresponding axis serving as the dependent (i.e., response) variable (see e.g., Presley & Willig, 2010; Keith et al., 2011; Willig et al., 2011 for a similar approach). We performed the analyses separately for each season and for the entire and the native assemblage levels, which yielded 18 multiple regression analyses (9 seasons \times 2 assemblage levels). Before data analyses, the environmental variables were transformed depending on their scale of measurement to improve normality and reduce heteroscedasticity (see Appendix I in Electronic Supplementary Material). Strongly collinear variables ($r > 0.7$) were omitted from further analyses. The explanatory variables were then screened via a forward selection procedure with Monte Carlo randomization tests (10,000 runs) to

obtain a reduced set of significant variables (variables retained at $P < 0.05$) for the final regression models (Blanchet et al., 2008). Regression models were fitted on the standardized dependent and independent variables [i.e., variables with 0 mean and 1 standard deviation (SD)] to yield standardized partial regression coefficients (i.e., beta coefficients) from the models (Quinn & Keough, 2002). Standardized partial regression coefficients are directly comparable with each other, and indicate the relative importance of the independent variables in explaining the variability of the dependent variable. The forward selections (Dray et al., 2009) and the regression models were conducted within the R statistical environment (R Development Core Team, 2012).

Results

Altogether we collected 39 species and 71,291 specimens during the 3-year study (Appendix II in Electronic Supplementary Material). Of the 39 species, 15 were regarded as rare species (for definition see “Materials and methods” section) and were omitted from the analyses. Hence 24 species (19 native and 5 non-native) were retained for further analyses. EMS revealed the existence of different patterns of metacommunity structure depending on time period and the assemblage level (entire assemblages or non-natives excluded). At the entire assemblage level (Table 1), two best-fit structures were identified across all sampling months, Gleasonian and quasi-Clementsian. However, Gleasonian structure occurred only in the first sample (spring of 2008), after which, quasi-Clementsian pattern (e.g., see Fig. 3) persisted for the remaining eight sampling occasions, suggesting metacommunity structure changed little over time. However, the variance explained by the first CoA axis was relatively low in each occasion and varied between 17.7 and 24.0%. Exclusion of non-natives influenced the results markedly (Table 2). After removing non-native species from the analyses, we observed Clementsian, quasi-Clementsian, Gleasonian, and random metacommunity structures; however, there was no clear trend in changes in metacommunity structure over time. Similar to the analyses at the entire assemblage level, the variance explained by the first CoA axis was relatively low in each season and varied between 18.2 and 25.9%.

Table 1 Results of the EMS analysis at the entire assemblage level (i.e., both native and non-native species included)

Date	Coherence		Species turnover				Boundary clumping			Coherence	Turnover	Clumping	Best-fit structure
	Abs	P	Mean	SD	Re	P	Mean	SD	P				
			M	M	M	M	M						
Sp-2008	333	<0.001	418.5	24.5	13320	0.013	8,069.2	2,121.6	0.98	0.504	Positive	NS	Gleasonian
Su-2008	292	0.002	385.8	30.4	9,215	0.826	8,774.7	1,997.0	1.85	<0.001	NS+	Positive	Quasi-Clementsian
Au-2008	243	<0.001	381.5	31.8	11,180	0.261	9,118.1	1,833.9	1.60	0.006	NS+	Positive	Quasi-Clementsian
Sp-2009	267	<0.001	416.7	26.3	13,609	0.169	1,069.7	2,115.9	2.39	<0.001	NS+	Positive	Quasi-Clementsian
Su-2009	271	<0.001	403.3	32.7	14,541	0.110	10,738.1	2,379.2	1.59	0.008	NS+	Positive	Quasi-Clementsian
Au-2009	344	0.0387	403.4	28.7	10,109	0.286	7,983.9	1,991.8	1.52	0.013	NS+	Positive	Quasi-Clementsian
Sp-2010	287	<0.001	424.1	36.9	14,155	0.386	12,090.2	2,382.4	1.77	0.003	NS+	Positive	Quasi-Clementsian
Su-2010	280	<0.001	415.9	33.9	17,707	0.182	13,937.4	2,827.1	2.06	<0.001	NS+	Positive	Quasi-Clementsian
Au-2010	290	0.0029	396.4	35.7	12,230	0.100	9,104	1,897.6	1.65	0.002	NS+	Positive	Quasi-Clementsian

Mean and SD values show the values calculated based on 1,000 iterations of a null matrix (see "Materials and methods" section for further details)

Abs the number of embedded absences in the ordinated (first axis of a CoA) matrix, Re species replacements, M Morisita's index, Sp spring, Su summer, Au autumn

Regression analyses indicated that the gradient in fish assemblage composition (i.e., CoA1) was well modeled with environmental variables (Tables 3, 4). Adjusted R^2 values varied between 0.479 and 0.774 at the entire assemblage level analyses (Table 3). The main environmental variables selected by the modeling procedure for both the entire and the native assemblage levels included altitude, pond area, and dissolved oxygen content; however, the statistical relationship and importance of each of these variables were not the same for each season. Adjusted R^2 values increased slightly after removing non-native species and ranged from 0.489 to 0.802 (Table 4), but the most influential variables remained the same (altitude, pond area, and dissolved oxygen content).

Discussion

The metacommunity structure of stream fishes in the catchment of Lake Balaton changed temporally and differed when non-native species were included in the analyses. At the entire assemblage level, the metacommunity structure was consistent with a quasi-Clementsian structure for every season except Spring 2008 in which case a Gleasonian distribution best-fit the data. On the contrary, a variety of metacommunity structures, including even random distribution pattern characterized the native assemblage level dataset, although quasi-Clementsian and Clementsian structures were dominant. These results show that species distributions were generally coherent, which indicates that species responded similarly to an environmental gradient. In our study, the environmental gradient that correlated the most with the primary axis scores of the CoA was predominantly defined by altitude, pond area, and dissolved oxygen content. Because the temporal extent of our study covered only 3 years, we discount water-basin level extinctions during the 3 years as being influential in these changes (Erős et al. unpublished results). Instead, we hypothesize that the temporal changes in metacommunity structure were attributable to changes in within and among site occupancy patterns of fishes driven largely by migration dynamics (i.e., local scale immigration and emigration events) and their responses to the environmental gradients.

Metacommunities with positive coherence and non-significant turnover have a non-random (i.e., quasi)

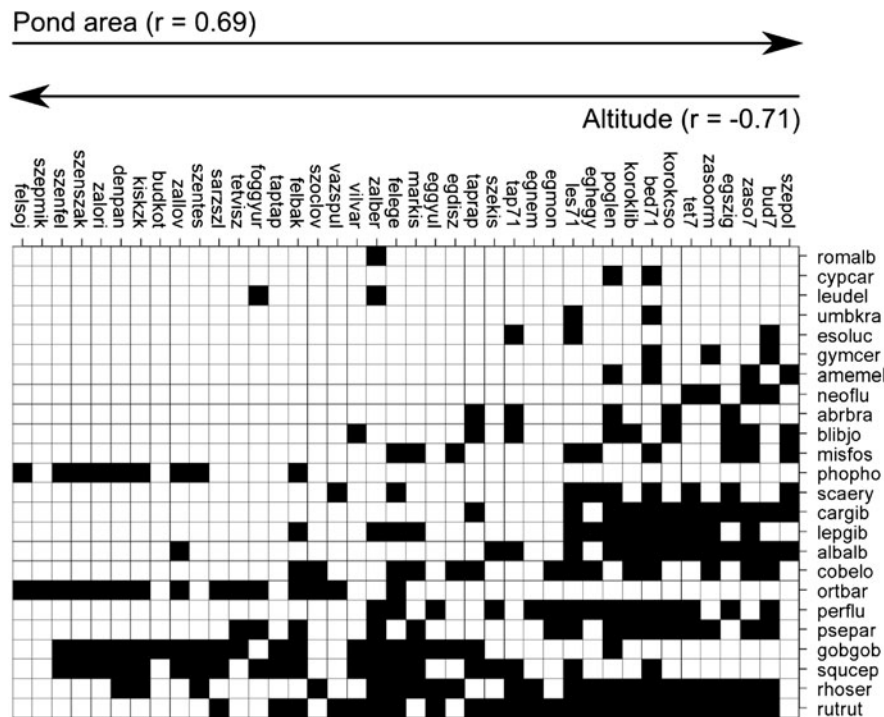

Fig. 3 An example for the most common best-fit pattern: incidence matrix of spring 2009 at the entire assemblage level showing a quasi-Clementsian metacommunity structure. Sites, in *columns* are ordered according to their position along the first CoA axis, whereas species are in the *rows*. Species name abbreviations can be found in Appendix II in Electronic Supplementary Material. *Arrows* indicate the changes of the

ecological gradients represented by the two key environmental variables along the first CoA axis. *Numbers in parenthesis* are the Pearson correlation coefficients of the key environmental variables with the CoA1. The Pearson correlation between variables altitude and pond area was -0.41 . See Appendix III in Electronic Supplementary Material for a more detailed environmental characterization of the sampling sites

structure (Fig. 1). These quasi-structures can emerge due to weaker structuring forces than those effecting idealized patterns (e.g., Clementsian, Gleasonian) in which turnover is significant (Presley et al., 2010). The most frequently occurring metacommunity structure and the only quasi-structure we observed was quasi-Clementsian. It indicated by positive coherence, non-significant positive turnover, and positive boundary clumping. This structure emerged because the distribution of many species spanned the entire compositional gradient, whereas other species were restricted to one end or the other of the CoA primary axis. For example, the Eurasian minnow (*Phoxinus phoxinus*) and the stone loach (*Barbatula barbatula*) always occupied only one half of the gradient, whereas the weatherfish (*Misgurnus fossilis*), the European perch (*Perca fluviatilis*), and some rare species typically occupied the other side of the gradient (Fig. 3). Both the stone loach and the Eurasian minnow are characteristic species of higher altitude streams, whereas the

many rare species occurring in the other side of the gradient are typical of lowland streams that have a more diverse fish assemblage composition than highland ones (Erős, 2007). On the contrary, the most common fishes, such as the chub (*Squalius cephalus*), bitterling (*Rhodeus sericeus*), gudgeon (*Gobio gobio*), and roach (*Rutilus rutilus*) were relatively abundant along the whole gradient. These results suggest that these fish are responding to an environmental gradient, but some species groups are responding differently to variation along that gradient.

The larger the variation in composition the more likely the metacommunity will have a “Quasi” component (Presley et al., 2010). In a recent study on stream fish assemblages, Hermoso & Linke (2012) found that assemblage level predictions from type-specific (i.e., environmental classification based) approaches were no different than random expectations. In fact, the models performed poorly as a result of high levels of within and among type variation, and

Table 2 Results of the EMS analysis at the native assemblage level (i.e., non-native species excluded)

Date	Coherence		Species turnover				Boundary clumping			Coherence	Turnover	Clumping	Best-fit structure	
	Abs	P	Mean	SD	Re	P	M	P						
Sp-2008	238	0.0016	308.2	22.3	9,316	0.0195	5,509.4	1,629.1	1.0053	0.4625	Positive	NS	Gleasonian	
Su-2008	202	0.0317	268.5	30.9	6,435	0.1343	4456.3	1,321.6	1.9432	0.0017	Positive	NS+	Positive	Quasi-Clementsian
Au-2008	156	<0.001	267.7	29.5	8,343	0.0519	5,693.9	1,362.7	1.7992	0.0054	Positive	NS+	Positive	Quasi-Clementsian
Sp-2009	201	<0.001	301.7	27.5	11,363	0.006	6,871.3	1,635.7	2.2984	<0.001	Positive	Positive	Positive	Clementsian
Su-2009	192	<0.001	298.2	29.1	8,949	0.0307	5,806.1	1,454.8	1.5114	0.0398	Positive	Positive	Positive	Clementsian
Au-2009	240	0.1483	289.9	34.5	6,159	0.165	4,416.1	1,255.2	1.471	0.0611	NS	NS+	NS	Random
Sp-2010	209	0.0028	307.6	33	10,209	0.1187	7,542	1,709.1	1.9218	0.0041	Positive	NS+	Positive	Quasi-Clementsian
Su-2010	217	0.0035	304.5	29.9	12,881	0.0051	7,639.9	1,871.9	1.6598	0.0027	Positive	Positive	Positive	Clementsian
Au-2010	224	0.0762	278.8	30.9	8,020	0.0134	4,801.5	1,301.3	2.2452	<0.001	NS	Positive	Positive	Random

Abs the number of embedded absences in the ordinated (first axis of a CoA) matrix, *Re* species replacements, *M* Morisita's index, *Sp* spring, *Su* summer, *Au* autumn
 Mean and SD values show the values calculated based on 1,000 iterations of a null matrix (see "Materials and methods" section for more details)

only site-specific approaches (i.e., continuum-based modeling techniques, which predict fish assemblages for each site separately) could predict the variability in assemblages to some degree. In this respect, our study supports this general conclusion in that species responded to the environmental gradient, but did not have enough turnover in species composition along that gradient to be statistically different than random, a result which was further supported by the low explained variance in the first axis of the CoA. However, the significant clumping is indicative of a Clementsian pattern and is consistent with differences in species composition between upland and lowland regions. In our study, altitude and pond area proved to be the most stable variables with which fish assemblage composition (CoA1 axis scores) correlated in most occasions. Artificial ponds (reservoirs, fish ponds) are most frequent in the lowland areas in this catchment (Sály et al., 2011; Erős et al., 2012), and therefore it is not surprising that the composition of the assemblages in this lowlands showed opposite reaction to altitude. Therefore, this study confirms previous findings in which Erős et al. (2012) applied a different analytical procedure (variance partitioning with redundancy analysis) and highlighted the fact that relatively small variations in altitude can contribute to changes in fish assemblage composition.

Previous studies that have used the EMS analysis to examine patterns of metacommunity structure have identified multiple idealized spatial patterns from a variety of species assemblages and ecosystem types (e.g., Presley et al., 2009; Presley & Willig, 2010; Hoverman et al., 2011; López-González et al., 2012). However, to our knowledge only one study examined coherence, species turnover, and boundary clumping (i.e., EMS) as a means of characterizing metacommunity structure of stream organisms in which Heino (2005) found that the spatial distributions of stream midges were most consistent with Gleasonian and nested patterns (Heino, 2005). Further, much of the emphasis on EMS has been spatial in nature with little focus on temporal variations. Of the few exceptions, Keith et al. (2011) observed no change in Clementsian structure of vascular plants in woodland patches approximately 70 years apart, despite a significant loss in beta diversity through taxonomic homogenization. For terrestrial gastropods of Puerto Rico, the spatial structure was least nested, or more random, immediately following a hurricane disturbance,

Table 3 Summary of results of the regression analyses between the environmental variables and the main fish assemblage gradient (i.e., first CoA axis) at the entire assemblage level (i.e., both native and non-native species included)

Date	Model	<i>F</i>	<i>P</i>	<i>R</i> ² adj
Sp-2008	$y = 0.569$ (altitude) $- 0.396$ (pa) $+ 0.223$ (dissolved oxygen content)	45.41	<0.001	0.774
Su-2008	$y = -0.581$ (altitude) $+ 0.397$ (pa)	40.40	<0.001	0.669
Au-2008	$y = -0.702$ (altitude)	36.89	<0.001	0.479
Sp-2009	$y = -0.518$ (altitude) $+ 0.471$ (pa)	41.41	<0.001	0.675
Su-2009	$y = -0.516$ (altitude) $+ 0.325$ (pa) $- 0.296$ (dissolved oxygen content)	25.80	<0.001	0.656
Au-2009	$y = -0.764$ (altitude)	53.33	<0.001	0.573
Sp-2010	$y = -0.492$ (altitude) $+ 0.442$ (pa)	29.97	<0.001	0.598
Su-2010	$y = -0.557$ (altitude) $+ 0.322$ (pa) $- 0.288$ (dissolved oxygen content)	32.51	<0.001	0.708
Au-2010	$y = 0.489$ (altitude) $- 0.179$ (CV depth) $+ 0.366$ (silt) $- 0.279$ (% wetland)	16.64	<0.001	0.616

Note that we calculated standardized regression coefficients [i.e., beta coefficients (Quinn & Keough, 2002)] from the a priori 0 mean and 1 SD standardized variables, so that the importance of each variable could be directly compared

Sp spring, *Su* summer, *Au* autumn, *pa* pond area

Table 4 Summary of results of the regression analyses between the environmental variables and the main fish assemblage gradient (i.e., first CoA axis) at the native assemblage level (i.e., non-native species excluded)

Date	Model	<i>F</i>	<i>P</i>	<i>R</i> ² adj
Sp-2008	$y = +0.521$ (altitude) $- 0.473$ (pa) $+ 0.275$ (dissolved oxygen content) $+ 0.249$ (% inhabited area)	40.37	<0.001	0.802
Su-2008	$y = -0.523$ (altitude) $+ 0.356$ (pa) $- 0.279$ (dissolved oxygen content)	30.30	<0.001	0.693
Au-2008	$y = -0.477$ (altitude) $+ 0.428$ (pa)	25.50	<0.001	0.557
Sp-2009	$y = 0.709$ (pa)	38.30	<0.001	0.489
Su-2009	$y = -0.506$ (altitude) $+ 0.335$ (pa) $- 0.292$ (dissolved oxygen content)	25.39	<0.001	0.652
Au-2009	$y = -0.574$ (altitude) $- 0.269$ (dissolved oxygen content) $+ 0.251$ (pa)	22.90	<0.001	0.628
Sp-2010	$y = 0.482$ (pa) $- 0.444$ (altitude)	28.58	<0.001	0.586
Su-2010	$y = -0.526$ (altitude) $+ 0.422$ (pa)	32.66	<0.001	0.619
Au-2010	$y = 0.159$ (altitude) $- 0.296$ (pa) $- 0.438$ (silt) $- 0.279$ (% wetland) $- 0.428$ (conductivity) $+ 0.271$ (% inhabited area)	15.66	<0.001	0.704

Note that we calculated standardized partial regression coefficients [i.e., beta coefficients (Quinn & Keough, 2002)] from the a priori 0 mean and 1 SD standardized variables, so that the importance of each variable could be directly compared

Sp spring, *Su* summer, *Au* autumn, *pa* pond area

becoming more nested as the forest recovered during secondary succession reducing spatial heterogeneity (Bloch et al., 2007). Although these examples are useful to highlight the growing body of the EMS literature, unfortunately, the idealized metacommunity structures identified in other studies and organisms are not directly comparable to our results, because the environmental gradients and responses of organisms are different. Of those studies where only single

distributional patterns were tested, nested distribution patterns have been found for both stream macroinvertebrates (Malmqvist & Hoffsten, 2000; Heino, 2011) and fishes (Taylor & Warren, 2001; Erős & Grossman, 2005). We did not find nested metacommunity structure in any occasion, although differences in species richness among sites were clearly important in this metacommunity. However, it is important to emphasize that EMS finds the best-fit pattern of

metacommunity structure from a set of idealized patterns. In this catchment, positive turnover (i.e., changes in species composition) along the environmental gradient was a stronger structuring force than factors that cause richness differences among sites (e.g., changes in habitat complexity from source to mouth, Erős & Grossman, 2005).

We observed temporal changes in metacommunity structure at the native assemblage level, but the structure remained relatively stable at the entire assemblage level. Removal of the non-native species allowed three of the quasi-Clementsian distributions observed at the entire assemblage level to become statistically significant in which case the overall spatial distribution was changed to Clementsian. However, in two other occasions the removal of non-natives yielded random pattern; in one occasion Gleasonian structure was found. These results suggest that the dominant Clementsian and quasi-Clementsian metacommunity structure of the native species can change in time in this catchment due to temporally variable species distribution patterns that may be due to movement of some species between sites and/or to the effect of seasonally differing environmental factors on species distributions. In fact, the response of species assemblages to the environmental gradient suggests the importance of niche-based processes in determining metacommunity structure in this landscape. However, dispersal processes, the relative influence of which can change over time (Erős et al., 2012), could obscure the importance of niche-based structuring so that even a random pattern could emerge at some occasions due to between site movements of fish.

This is the first time, to our knowledge, that shows that non-native species can homogenize temporal patterns in metacommunity structure. Since the occurrence of non-native species was rather restricted to the lowlands, whereas a few native species was the only characteristic species of the most highland streams (e.g., stone loach, Eurasian minnow, see Fig. 3) it is not surprising that inclusion of non-natives in the analyses could change the observed random pattern at the native assemblage level (Autumn 2009 and 2010) to become quasi-Clementsian at the entire assemblage level. However, the observed change from Clementsian distribution at the native assemblage level to quasi-Clementsian at the entire assemblage level can be due to a variety of effects, including the rather

unpredictable occurrence of both native and non-native species among individual sites. Our study thus highlights that distribution pattern of non-natives should be separately evaluated from those of native species when seeking for the best-fit metacommunity structure in landscapes where non-natives are present.

Mechanism-based (Erős et al., 2012) and our pattern-based approaches both show moderate responses (here turnover) of fish assemblages to environmental gradients in this landscape. Although we found quasi-Clementsian structure to be the most dominant metacommunity structure, our analyses indicated temporal variability in the best-fit metacommunity structure depending on which assemblage level was used in the analyses. The difference in species composition and associated distributions between highland and lowland streams likely accounts for a majority of the clustering of species, a hypothesis supported by the fact that altitude was one of the primary environmental factors. Since compositional changes of fishes along long environmental gradients are relatively well known, we believe that further studies are necessary from other regions to examine best-fit metacommunity structures of stream fishes within relatively short environmental gradients. This could help to better understand the predictability of fish assemblages to subtle changes in environmental heterogeneity and the dominant ecological mechanisms.

Acknowledgments We express our thanks to Jani Heino for the continuing discussions about metacommunities. We would also like to express our thanks to two anonymous reviewers for their very thorough review of the manuscript and suggestions for improvements. The study was supported by the OTKA K69033 research fund. T. Erős was supported by the János Bolyai Research Scholarship of the Hungarian Academy of Sciences and the OTKA K107293 research fund.

References

- Aarts, B. G. W. & P. H. Nienhuis, 2003. Fish zonation and guilds as the basis for assessment of ecological integrity of large rivers. *Developments in Hydrobiology* 171: 157–178.
- Baselga, A., 2010. Partitioning the turnover and nestedness components of beta diversity. *Global Ecology and Biogeography* 19: 134–143.
- Blanchet, F. G., P. Legendre & D. Borcard, 2008. Forward selection of explanatory variables. *Ecology* 89: 2623–2632.
- Bloch, C. P., C. L. Higgins & M. R. Willig, 2007. Effects of large scale disturbance on metacommunity structure of terrestrial gastropods: temporal trends in nestedness. *Oikos* 116: 395–406.

- Clements, F. E., 1916. *Plant Succession: An Analysis of the Development of Vegetation*. Carnegie Institute of Washington, Washington, DC.
- Diamond, J. M., 1975. Assembly of species communities. In Cody, M. L. & J. M. Diamond (eds), *Ecology and Evolution of Communities*. Harvard University Press, Cambridge.
- Dray, S., P. Legendre & G. Blanchet, 2009. packfor: Forward Selection with Permutation (Canoco p.46). R package version 0.0-7/r58.
- Erős, T., 2007. Partitioning the diversity of riverine fish: the roles of habitat types and non-native species. *Freshwater Biology* 52: 1400–1415.
- Erős, T. & G. D. Grossman, 2005. Fish biodiversity in two Hungarian streams—a landscape based approach. *Archiv für Hydrobiologie* 162: 53–71.
- Erős, T., P. Sály, P. Takács, A. Specziár & P. Bíró, 2012. Temporal variability in the spatial and environmental determinants of functional metacommunity organization—stream fish in a human modified landscape. *Freshwater Biology* 57: 1914–1928.
- Fridley, J. D., J. J. Stachowicz, S. Naeem, D. F. Sax, E. W. Seabloom, M. D. Smith, T. J. Stohlgren, D. Tilman & B. Von Holle, 2007. The invasion paradox: reconciling pattern and process in species invasions. *Ecology* 88: 3–17.
- Gleason, H. A., 1926. The individualistic concept of the plant association. *Bulletin of the Torrey Botanical Club* 53: 7–26.
- Grossman, G. D., R. E. Ratajczak, M. D. Farr, C. M. Wagner & J. D. Petty, 2010. Why there are fewer fish upstream. In Gido, K. B. & D. A. Jackson (eds) *Community Ecology of Stream Fishes: Concepts, Approaches, and Techniques*. American Fisheries Society, Symposium 73, Bethesda: 63–82.
- Heino, J., 2005. Metacommunity patterns of highly diverse stream midges: gradients, chequerboards, and nestedness, or is there only randomness? *Ecological Entomology* 30: 590–599.
- Heino, J., 2011. A macroecological perspective of diversity patterns in the freshwater realm. *Freshwater Biology* 56: 1703–1722.
- Heino, J., T. Muotka, H. Mykrä, R. Paavola, H. Hämäläinen & E. Koskeniemi, 2003. Defining macroinvertebrate assemblage types of headwater streams: implications for bioassessment and conservation. *Ecological Applications* 13: 842–852.
- Hermoso, V. & S. Linke, 2012. Discrete vs. continuum approaches to the assessment of the ecological status in Iberian rivers, does the method matter? *Ecological Indicators* 18: 477–484.
- Hoeinghaus, D. J., K. O. Winemiller & J. S. Birnbaum, 2007. Local and regional determinants of stream fish assemblage structure: inferences based on taxonomic vs. functional groups. *Journal of Biogeography* 34: 324–338.
- Holyoak, M., M. A. Leibold & R. D. Holt (eds), 2005. *Metacommunities: Spatial Dynamics and Ecological Communities*. University of Chicago Press, Chicago: 513 pp.
- Hoverman, J. T., C. J. Davis, E. E. Werner, D. K. Skelly, R. A. Relyea & K. L. Yurewicz, 2011. Environmental gradients and the structure of freshwater snail communities. *Ecography* 34: 1049–1058.
- Hughes, R. M. & D. V. Peck, 2008. Acquiring data for large aquatic resource surveys: the art of compromise among science, logistics, and reality. *Journal of the North American Benthological Society* 27: 837–859.
- Ibarra, A. A., Y.-S. Park, S. Brosse, Y. Reyjol, P. Lim & P. Lek, 2005. Nested patterns of spatial diversity revealed for fish assemblages in a west European river. *Ecology of Freshwater Fish* 14: 233–242.
- Jackson, D. A., P. R. Peres-Neto, J. D. Olden, 2001. What controls who is where in freshwater fish communities the roles of biotic, abiotic, and spatial factors. *Canadian Journal of Fisheries and Aquatic Sciences* 58: 157–170.
- Keith, S. A., A. C. Newton, M. D. Morecroft, D. J. Golicher & J. M. Bullock, 2011. Plant metacommunity structure remains unchanged during biodiversity loss in English woodlands. *Oikos* 120: 302–310.
- Lake, P. S., 2000. Disturbance, patchiness and diversity in streams. *Journal of the North American Benthological Society* 19: 573–592.
- Lasne, E., B. Bergerot, S. Lek & P. Laffaille, 2007. Fish zonation and indicator species for the evaluation of the ecological status of rivers: example of the Loire basin (France). *River Research and Applications* 23: 877–890.
- Legendre, P. & L. Legendre, 1998. *Numerical Ecology*. Elsevier, Amsterdam: xv + 853.
- Leibold, M. A. & G. M. Mikkelsen, 2002. Coherence, species turnover and boundary clumping: elements of a metacommunity structure. *Oikos* 97: 237–250.
- Leibold, M. A., M. Holyoak, N. Mouquet, P. Amarasekare, J. M. Chase, M. F. Hoopes, R. D. Holt, J. B. Shurin, R. Law, D. Tilman, M. Loreau & A. Gonzalez, 2004. The metacommunity concept: a framework for multi-scale community ecology. *Ecology Letters* 7: 601–613.
- López-González, C., S. J. Presley, A. Lozano, R. D. Stevens & C. L. Higgins, 2012. Metacommunity analysis of Mexican bats: environmentally mediated structure in an area of high geographic and environmental complexity. *Journal of Biogeography* 39: 177–192.
- Magalhães, M. F., D. C. Batalha & M. J. Collares-Pereira, 2002. Gradients in stream fish assemblages across a Mediterranean landscape: contributions of environmental factors and spatial structure. *Freshwater Biology* 47: 1015–1031.
- Malmqvist, B. & P.-O. Hoffsten, 2000. Macroinvertebrate taxonomic richness, community structure and nestedness in Swedish streams. *Archiv für Hydrobiologie* 150: 29–54.
- Matthews, W. J., 1998. *Patterns in Freshwater Fish Ecology*. Chapman & Hall, New York.
- Morisita, M., 1971. Composition of the I-index. *Researches on Population Ecology* 13: 1–27.
- Patterson, B. D. & W. Atmar, 1986. Nested subsets and the structure of insular mammalian faunas and archipelagos. *Biological Journal of the Linnean Society* 28: 65–82.
- Presley, S. J. & M. R. Willig, 2010. Bat metacommunity structure on Caribbean islands and the role of endemics. *Global Ecology and Biogeography* 19: 185–199.
- Presley, S. J., C. L. Higgins, C. López-González & R. D. Stevens, 2009. Elements of metacommunity structure of Paraguayan bats: multiple gradients require analysis of multiple axes of variation. *Oecologia* 160: 781–793.

- Presley, S. J., C. L. Higgins & M. R. Willig, 2010. A comprehensive framework for the evaluation of metacommunity structure. *Oikos* 119: 908–917.
- Quinn, G. P. & M. J. Keough, 2002. *Experimental Design and Data Analysis for Biologists*. Cambridge University Press, Cambridge: 556 pp.
- R Development Core Team, 2012. *R: A Language and Environment for Statistical Computing*. R Foundation for Statistical Computing, Vienna. <http://www.r-project.org/>.
- Resh, V. H., A. V. Brown, A. P. Covich, M. E. Gurtz, H. W. Li, G. W. Minshall, S. R. Reice, A. L. Sheldon, J. B. Wallace & R. C. Wissmar, 1988. The role of disturbance in stream ecology. *Journal of the North American Benthological Society* 7: 433–455.
- Sály, P., T. Erős, P. Takács, A. Specziár, I. Kiss & P. Bíró, 2009. Assemblage level monitoring of stream fishes: the relative efficiency of single-pass vs. double-pass electrofishing. *Fisheries Research* 99: 226–233.
- Sály, P., P. Takács, I. Kiss, P. Bíró & T. Erős, 2011. The relative influence of spatial context and catchment and site scale environmental factors on stream fish assemblages in a human-modified landscape. *Ecology of Freshwater Fish* 20: 251–262.
- Schlösser, I. J., 1991. Stream fish ecology—a landscape perspective. *Bioscience* 41: 704–712.
- Schmutz, S. A., A. Melcher, C. Frangez, G. Haidvogel, U. Beier, J. Böhmer, J. Breine, I. Simoens, N. Caiola, A. de Sostoa, M. T. Ferreira, J. Oliveira, G. Grenouillet, D. Goffaux, J. J. de Leeuw, R. A. A. Noble, N. Roset & T. Virbickas, 2007. Spatially based methods to assess the ecological status of riverine fish assemblages in European ecoregions. *Fisheries Management and Ecology* 14: 441–452.
- Statzner, B. & B. Higl, 2006. Stream hydraulics as a major determinant of benthic invertebrate zonation patterns. *Freshwater Biology* 16: 127–139.
- Taylor, C. M., 1997. Fish species richness and incidence patterns in isolated and connected stream pools: effects of pool volume and spatial position. *Oecologia* 110: 560–566.
- Taylor, C. M. & M. L. Warren, 2001. Dynamics in species composition of stream fish assemblages: environmental variability and nested subsets. *Ecology* 82: 2320–2330.
- Tilman, D., 1982. *Resource Competition and Community Structure*. Princeton University Press, Princeton.
- Ulrich, W., M. Almeida-Neto & N. J. Gotelli, 2012. A consumer's guide to nestedness analysis. *Oikos* 118: 3–17.
- Wang, L., J. Lyons, P. Rasmussen, P. Seelbach, T. Simon, M. Wiley, P. Kanehl, E. Baker, S. Niemela & P. M. Stewart, 2003. Watershed, reach, and riparian influences on stream fish assemblages in the Northern Lakes and Forest Ecoregion, U.S.A. *Canadian Journal of Fisheries and Aquatic Sciences* 60: 491–505.
- Willig, M. R., S. J. Presley, C. P. Bloch, I. Castro-Arellano, L. M. Cisneros, C. L. Higgins & B. T. Klingbeil, 2011. Tropical metacommunities along elevational gradients: effects of forest type and other environmental factors. *Oikos* 120: 1497–1508.