



The AGILE Gamma-Ray observatory: software and pipelines

Software management approach and lessons learned for the next generation of high-energy observatories

Andrea Bulgarelli¹ 

Received: 1 April 2019 / Accepted: 10 October 2019 / Published online: 18 December 2019
© Springer Nature B.V. 2019

Abstract

In this paper is described the approach used to develop the software system of the AGILE γ -ray Observatory, from the definition phase to construction, verification and calibration activities of the satellite, until operations for scientific observations. Flexible software architectures, effective software management workflow, new algorithms (from payload simulators to reconstruction algorithms, from detection algorithms for Real-Time Analysis systems to the follow-up of science alerts in the multi-wavelength and multi-messenger context) and team management approach are described. The approach followed by the AGILE Team in more than twenty years of work is a key element of the success of the AGILE Observatory, and the foundation for the involvement in new high-energy telescopes and observatories. Our legacy is not only in experience and tools but also in lesson learned, that are described in this work.

Keywords Observatory · Data acquisition · Gamma-ray

1 Introduction

AGILE, the Italian satellite for the exploration of the γ -ray sky, was launched on April 23, 2007, from the Indian space base of Sriharikota with a very precise insertion in a 550 km high equatorial orbit. After a few hours, the first engineering data from the satellite confirmed the success of the launch and the first scientific data were received, processed and archived at the ASI Data Center (SSDC) and at the INAF scientific institutes. At the beginning of July 2007 the scientific verification phase of

✉ Andrea Bulgarelli
andrea.bulgarelli@inaf.it

¹ INAF/OAS Bologna, Via Gobetti 93/3, Bologna, Italy

the γ -ray telescope was completed: AGILE was performing nominally, and scientific observations started. Immediately, the AGILE telescope detected the most brilliant sources (the pulsars Vela, Geminga and Crab, the most intense γ -ray sources in the AGILE energy band), but especially between 24 and 30 July, following the notification of other observatories, AGILE changed its pointing and began the observation of the blazar 3C 454.3. AGILE immediately recorded an intense emission of γ -rays. The flux of the source rapidly increased, and 3C 454.3 soon became one of the brightest sources of the γ -ray sky. An early version of an automated processing system allowed the AGILE Team to follow the phenomena during the observation, and the first Astronomer's Telegram was issued immediately [46]. This γ -ray flare immediately revealed to us all the ability of AGILE system to follow the variable phenomena in real-time. This experience was one of the main drivers for the development in the following years of the **AGILE Real-Time Analysis (RTA)**, a software pipeline that analyse the AGILE data in real-time to detect γ -ray flares or GRBs from AGILE data or to react to external science alert from other instruments.

How was it possible for the AGILE Team to acquire and process data and to have an automatic data analysis system running immediately after the launch, considering that, together with the Italian space industry, until the day of the launch the team was involved in the construction and testing of the satellite? To understand the role of the software, and of his management, we must go back to the beginning of the AGILE project, and focus on three systems developed during the definition phases (a.k.a. A and B) and construction phases (C and D) of a space mission, the have been reused during the operational phase E:

1. the P/L (Payload) simulators, that has enabled us to have a full data generation chain in the early phase of the project for the development of the entire software system for engineering and scientific verification activities (Section 4);
2. the assembly, integration and verification (AIV) software and its full reuse in the Ground Segment; (Section 5);
3. the Science Tools, for the scientific analysis of AGILE data (Section 6).

The instrument and the data flow are described in Sections 2 and 3 respectively. Section 4 describes the P/L simulators and their role in the AGILE development workflow, Section 5 describes the AIV software and its complete reuse in the AGILE Ground Segment. Section 6 describes the reconstruction software and the Science Tools, the building blocks of the AGILE Real-Time Analysis, described in Section 7 together with the transient γ -ray sky follow-up strategy. Finally, Section 8 and Section 9 reports lesson learned and how our tools could be reused for future γ -ray observatories.

2 The instrument

AGILE (Astrorivelatore Gamma ad Immagini LEggero, Light Imager for Gamma-Ray Astrophysics) is a scientific mission of the Italian Space Agency (ASI) for γ -ray astrophysics [40]. The AGILE payload detector consists of a silicon tracker (ST) [4, 12, 17, 38] the SuperAGILE X-ray detector [24], the CsI(Tl) Mini-Calorimeter

(MCAL) [29], and an anti coincidence system (ACS) [35]. The combination of ST, MCAL and ACS forms the Gamma-Ray Imaging Detector (GRID), for observations in the energy range 30 MeV-50 GeV. Accurate timing, positional and attitude information are provided by a precise positioning system (PPS) and the two star sensors (SS) units. The ST is the core of the AGILE-GRID, and it relies on the process of photon conversion into electron-positron pairs. It consists of a total of 12 trays, the first 10 of which consist by a tungsten converter followed by a pair of silicon microstrip detectors with strips orthogonal to each other, the last two consisting only of the silicon detectors. The γ -rays are converted in the tungsten layers, and a readout electronics acquire and process the data. MCAL is composed of 30 CsI(Tl) scintillator bars each one $15 \times 23 \times 375 \text{mm}^3$ in size, arranged in two orthogonal layers, for a total thickness of 1.5 radiation lengths. The AC system is aimed at a very efficient charged particle background rejection; it surrounds all AGILE detectors (Super-AGILE, ST and MCAL). The AGILE-GRID event processing is operated by the payload data handling unit (PDHU) that provides onboard trigger logic algorithms [3].

3 The data flow

AGILE scientific data (about 300 Mbit/orbit) are sent from the satellite to the ASI ground station in Malindi (Kenya) at every satellite passage (about 96 minutes) in telemetry data format [18] (a.k.a raw data format). A fast ASINET connection between Malindi and the Mission Operation Centre (MOC) at Fucino send the data to the Telespazio Satellite Control Center (SCC). The ASINET ensures every orbit the data communication between Fucino and the ASI Space Science Data Center (SSDC) where the AGILE Science Operation Center (SOC) is located. The AGILE MOC is located at Fucino and is operated by Telespazio with scientific and programmatic input by ASI and the AGILE Team through the SSC.

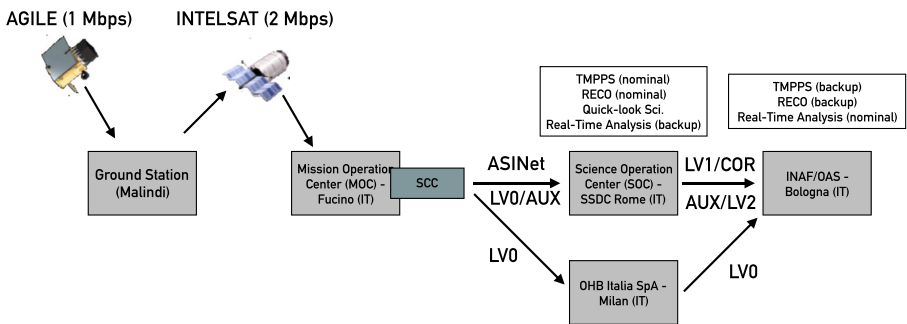

Fig. 1 Agile TM data flow. Every ~ 96 minutes the satellite passes over the Malindi (Kenya) Ground Station. At each pass, the satellite telemetry is downlinked and forwarded in near real-time to the Mission Operations Centre (MOC) via INTELSAT. Telemetry is then transferred by the MOC Satellite Control Centre (SCC) to the AGILE Science Operation Center (SOC) at the ASI Space Science Data Center (SSDC) and then to the INAF/OAS site. A backup chain from OHB Italia SpA in Milan is also present. The main software systems are also listed in the white boxes and described in the text

Raw data are routinely archived at SOC and converted to a FITS format¹ called LV1 (preprocessed data) through the AGILE Telemetry Preprocessing System (TMPPS) [43]. Auxiliary files (AUX, with information about orbits and attitude prevision) are also sent to SOC. LV1 are converted in COR files, that give a temporal correction of LV1. Data are further processed to produce LV2, i.e. the EVT files (the photon list) and LOG files that describe the status of the satellite. LV1 are transformed in LV2 at SOC by means of a reconstruction (RECO) system (see Section 6). In the first version of the AGILE Real-Time Analysis the LV1 data was forwarded from SSCD to the INAF/OAS site where they were processed by AGILE Real-Time Analysis pipelines. With the second version of the AGILE Real-Time Analysis, the COR, AUX and LV2 data are forwarded from SSCD to the INAF/OAS site.

Scientific processing produces LV3 data, or sky maps, using the Science Tools developed by the AGILE team (see Section 6). Scientific processing is performed at both sites. A pipeline on AGILE-GRID data is developed at SOC for quick look monitoring and consolidated archive generation and is called Quick-Look Scientific pipeline (see Section 7.1.1 and [37]). The rest of the AGILE Real-Time Analysis is developed at INAF/OAS Bologna site (see Section 7 for a full description of the first and second version of the AGILE-Real-Time Analysis). In the past, with the first version of the AGILE Real-Time Analysis, also the INAF/IAPS Rome site was involved in this data flow to analyse AGILE-SA data.

There is a backup chain that runs from Telespazio to OHB Italia SpA in Milan (formerly Compagnia Generale dello Spazio - CGS) and then to the INAF/OAS site, that is activated only when problems occur in the nominal flow chain and only after the Mission Director's authorisation; the backup chain runs a backup version of the TMPPS and a simplified version of the reconstruction system from LV0 to LV2 that is used as input for the AGILE Real-Time Analysis. A backup system of the second version of the AGILE Real-Time Analysis is also present at SOC and activated by the AGILE Team when there are problems at the Bologna's site. Figure 1 shows the data flow and the main systems.

A very important aspect of the AGILE software system is that the data formats (the hardware-driven satellite telemetry data format defined by CCSDS, and NASA/FITS data format widely recognised by the astrophysical community) and the internal data structure were defined in the initial phases of the project (before the start of the AIV phase), and since then they are not changed. The choice of data format and data structure at the beginning of the mission allowed the AGILE Team to develop and maintain the AGILE software system in an iterative and incremental way, with a development process lasted 20 years and still ongoing, where the data acquired in all mission phases or produced by simulators are accessible with all software versions. The NASA/FITS data format allows also the storing of the metadata information (data format evolution, software version used to produce the files) within the file headers, allowing to track changes in a simple way.

¹<https://fits.gsfc.nasa.gov>

4 The role of the satellite simulators: GAMS and DHSIM

The construction of the AGILE satellite started in the late nineties. In the initial phases of each space mission the hardware is not available, and the effort is focused on the design of the instrument. To support this initial phase the AGILE Team have developed P/L simulators. One of the primary advantages of simulators is that they can provide scientists with practical feedback when designing real-world systems like a space segment of a γ -ray mission. This allows the scientists to determine the correctness and efficiency of a design before the system is constructed, and to support the construction phase, in particular, the verification of the P/L.

For these reasons, these simulators are critical components of the entire AGILE software system, not only because they are fundamental along the entire development process (from the instrument design to the verification and calibration phase), but also for the development of the software for AIV (see Section 5) and for the development of the reconstruction software (see Section 6).

For the AGILE space mission, we have developed two categories of satellite simulators, two Payload simulators (the new P/L simulator is described in Section 9.2.1) and a PDHU simulator.

4.1 The first AGILE Payload simulator: GAMS

During the definition phase and for the evaluation of the scientific performances a Monte Carlo simulator based on particles transport codes (e.g. the Geant3 or Geant4 toolkit²) is needed to create a virtual model of the entire high-energy space mission. In this way, we can simulate the interaction of the particles and photons inside the matter to optimise and understand the instrument.

The AGILE Payload Monte Carlo simulator developed in the early phase of the project, and still used, is called **GAMS** (Geant Agile Montecarlo Simulator) [21, 31]. By using a complete and detailed model of the AGILE instrument, the simulation of the interaction of γ -ray photons into the telescope was performed, together with the the onboard trigger logic, with in-depth optimisation study of trigger configuration for the cosmic γ -ray signals and the rejection of the particles and albedo-photon backgrounds in a 550 km equatorial orbit. Based on these studies, was also possible to define the fundamental parameters of the scientific instrument, i.e. the effective area, the point spread function (PSF) and energy dispersion (EDP), that constitutes the instrument response functions (IRFs), and finally the sensitivity of the instrument [20]. This was a first fundamental step in the construction of the AGILE instrument and for the definition of the trigger logic of the PDHU.

4.2 The data handling simulator: DHSIM

The GRID trigger logic for the acquisition of γ -ray photons and background rejection is very complex and is structured in two main levels: Level-1 and Level-2 trigger

²<http://geant4.web.cern.ch>

stages [3]. An intermediate Level-1.5 stage is also envisioned, with the acquisition of the event topology based on the identification of chips (TAA1) that acquire the fired silicon strips. Both Level-1 and Level-1.5 have a hardware-oriented veto logic providing a first cut of background events. Level-2 data processing includes a GRID readout and pre-processing cluster data acquisition. Level-2 processing is asynchronous. A set of memory buffers and burst search algorithms are implemented to maximise data acquisition for transient γ -ray events (e.g., a GRBs) in the ST, Super-AGILE and MCAL, respectively.

To manage the high complexity of the onboard processing, the AGILE Team developed a PDHU simulator called Data Handling Simulator (**DHSIM**), a full simulator implemented in software [3]. The main purposes of the DHSIM are (i) to prepare and test the telecommands sent to the P/L; the simulator verifies these commands before uploading them on the real PDHU, and (ii) to generate telemetry in LV1 data format as output of a simulated onboard data processing starting from GAMS Monte Carlo data. Thanks to this last feature, simulated and real data have the same data format: an essential feature for the next steps (see Fig. 2).

A dedicated database developed by the AGILE Team stores and manages the onboard configuration.

4.3 The advantages of a full simulation chain

There are a lot of advantages if Monte Carlo and real data (i.e. data acquired from the PDHU) have the same structure (the LV1 data format), and if the common data format is also the final data format of the project. As already said, from Monte Carlo data it is possible to get LV1 format thanks to the use of the DHSIM. From LV1, the data processing follows the elaboration applied to real data. This is a fundamental feature for the development of the overall software system of the AGILE mission, in particular, this has speed-up and enabled

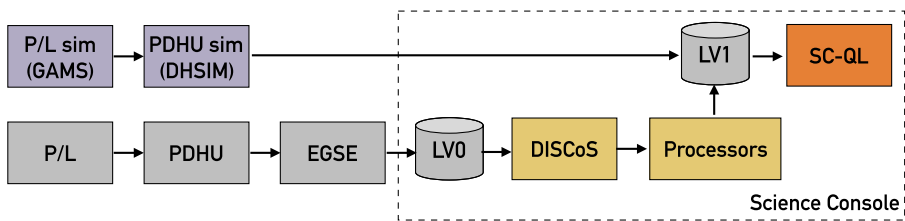

Fig. 2 The figure shows the workflow that includes the P/L, the P/L simulator (GAMS), the PDHU, the PDHU simulator (DHSIM) and the AIV Science Console. LV1 is the standard data format between the simulators and the real space segment. The EGSE is a tool to integrate and validate the electrical and communication interfaces of the P/L and provides an interface to the Science Console, a system that supports the science team and the industry during the construction phase. DISCoS and the processors are the Science Console Data Acquisition System, SC-QL is the on-line analysis quick-look used for the verification of the P/L

1. the development of the AIV software during the definition phase, because the interface of the AIV software is the real PDHU, but with the DHSIM was possible to start the development of the AIV software in the early phases (see Fig. 2);
2. the calibration of the AGILE P/L, to prepare the software before the calibration campaign;
3. the development of the on-ground event filters [16], aiming at the selection of events and to their classification;
4. the development of the Science Tools and the definition of the IRFs;
5. the development of the AGILE Real-Time Analysis pipelines.

For these reasons, a full simulation chain is the first pillar that has allowed the AGILE Team to be ready with the scientific Real-Time Analysis just after the launch. In Section 5 we analyse the second pillar: the strict collaboration between all AGILE Team members around a unique system, the AIV software, and its full reuse in the Ground Segment.

5 The AIV software and its evolution to the Ground Segment

In the context of the AGILE project an AIV a software framework called **Science Console** (a.k.a. Instrument Workstation) [8, 26, 42], has been extensively used to support the assembly, integration and verification (AIV) activities carried out for the AGILE satellite, from unit to payload level, the calibration campaign (at the Frascati facility in 2006), qualification campaign (during the period 2006 June-July and February-March, 2007 at the IABG facility in Munich (Germany)), launch campaign and in-orbit commissioning.

The Science Console (see Fig. 2) is a Linux workstation connected to the PDHU through an EGSE (Electric Ground Support Equipment) procured by industry. The EGSE is an essential tool which allows to integrate and validate the electrical and communication interfaces of the P/L during the construction and launch phases and provides an interface to the Science Console. The main purpose of the Science Console is to support the science team and the industry during the various phases of the AIV of the satellite, providing a set of scientific-oriented tools that enable the analysis and the verification of the PDHU functionalities and P/L performances. Many Science Consoles has been developed during the AGILE construction phase, some specialised for specific instruments (e.g. the MCAL [9]), a Science Console specific for calibration [17], and the final science console for the entire P/L.

The Science Console Data Acquisition System (**DISCoS**, [26], see Fig. 2) receives the echo of the telemetry data and the telecommand data exchanged by the EGSE with the P/L, and processes, converts and archives the telemetry LV0 data into LV1 files thanks to software components called **processors**.

The LV1 archive generated by DISCoS system is the primary input for the **Science Console Quick Look** (SC-QL or QL) [10]. The SC-QL software performs the following functions: (i) to process and display the scientific data coming from the AGILE instruments (as output of the PDHU) for engineering verification purposes

(see Fig. 3); (2) to perform the health assessment of the detectors and the overall P/L by means of the housekeeping displays, and to provide a high-level view of the content of the scientific data; (3) to display the ratemeters of each instrument; (4) to check the correct status of the P/L in all the phases of the AGILE construction phase. One of the main features of the QL is its ability to work in real-time (i.e. during the data acquisition) and off-line (retrieving data from the archive); the real-time display of the data enabled the AGILE Team and the industrial partners to check the status and the health of all the subsystems of the AGILE satellite during the tests, and to stop the test immediately if something was malfunctioning.

5.1 The reuse of the AIV software at MOC and SOC

The AGILE Team, including the software developers, took an active part in the AGILE construction and calibration phases. In particular, the active participation of the software developer team in the AIV phase, and the strict collaboration with the AGILE instrument, system and science teams allowed the AGILE Team to focus

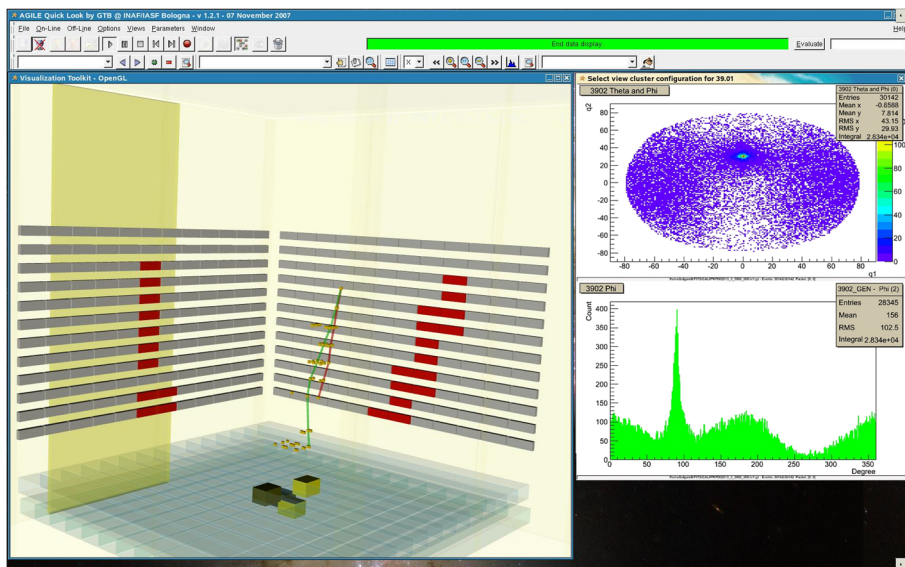

Fig. 3 On the left, a 3D view of the AGILE P/L that show the full topology of a single GRID event. The grey horizontal blocks are the Silicon Tracker chips not fired, the red horizontal blocks are the fired chips (a fired chip is a chip with one or more clusters of silicon strips that has passed the trigger level logic). The two tracks (red and green) are the converted electron and positron of the initial γ -ray; the small yellow boxes are a 3D projection of the clusters on ST plans (not shown). On the bottom of the AGILE 3D view is shown the MCAL (cyan bars) and the hit on MCAL bars generated by the converted electron and positron (yellow blocks into the cyan bars - the gradient of this blocks is proportional to the energy deposit). Finally, the big yellow vertical box is a fired lateral panel of the AC system. On the right, in the first window an example of a 2D display, where is shown the real-time reconstructed direction θ , ϕ of electrons acquired during the calibration campaign in Frascati. In the second window only the reconstructed ϕ direction is shown

the effort around a single system, the Science Console, which grew with the experience of the team acquired during the construction phase (AIV, calibration, launch campaign and commissioning). In particular, the SC-QL included not only the necessary engineering checks, but also became a collector of advanced knowledge on some instruments (thanks to the close interaction between the instrument teams and the software developers), and algorithms of data reconstruction (thanks to the collaboration between software developers and science team, see Figs. 3 and 4).

Some members of the software developer team were also included in the AGILE system team, and this allowed daily participation of software developers in AIV operations in strict collaboration with the industries involved in the construction of AGILE, allowing developers to understand the instrument, the on-going testing activities and to adapt the SC-QL software according.

The flexibility of the SC-QL, that was part of its requirements and design (i.e. the system must be flexible to include new algorithms and an high level of customisation of the data checks and visualization). Even if the initial development of a highly flexible system required at more initial effort, this approach allowed maximising the effectiveness of the work performed during the construction phase, in which the AIV software became a fundamental part of the whole AGILE software system. For these reasons the knowledge included in this software system was not lost, but entirely reused in the Ground Segment, at both MOC and SOC (see Fig. 5), i.e. during the operational phase. This has allowed maximising the reuse of code, and to preserve the knowledge learned during the AIV campaign.

The SC-QL is used in the AGILE Ground Segment in different ways. The QL (i) was the only validation tool for the P/L, also used during the in-flight commissioning

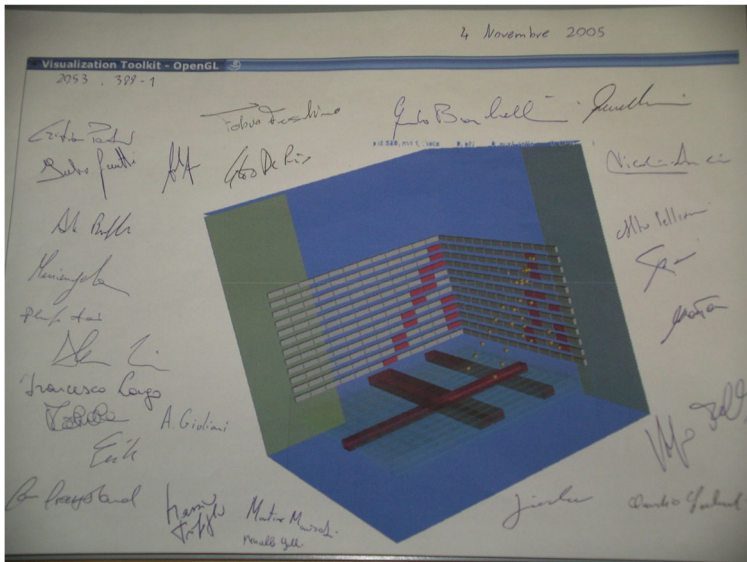

Fig. 4 The first γ -ray photon acquired during the calibration campaign in Frascati in a 3D view of the AGILE P/L displayed by the SC-QL

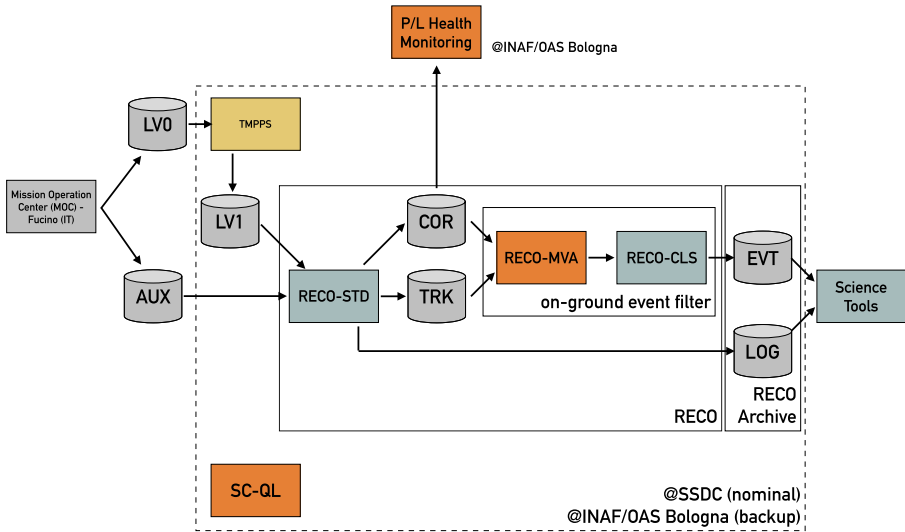

Fig. 5 The workflow from LV0 to LV3 and the relationship with the AIV software. Yellow and orange boxes are software derived or reused from the AIV software. TMPPS runs at SOC in SSDC and the P/L Health monitoring is used by MOC people to check the status of the P/L. The RECO system (RECO-STD and on-ground event filter) and the Science Tools are the core of the AGILE Science Alert System and of the Quick-Look Scientific pipeline and runs in two sites: at INAF/OAS Bologna site and at SOC. RECO Archive stores LV2 files, that can be downloaded from SSDC website. TRK files contain the reconstructed incident direction and energy of the events in the AGILE-GRID reference system. The Science Tools, which are publicly available from the AGILE website at SSDC, can be also downloaded and run on single-user machines. A version of the SC-QL is available in SSDC and used in case of P/L problems

phase. A version of the QL is always available in SSDC and used in case of problems at the P/L during the operational phase; (ii) the QL was converted into a web application that is officially released to Telespazio at MOC, for the daily control of the state of the P/L (the **P/L Health Monitoring**); (iii) the QL is one component of the on-ground event filters, the RECO-MVA that generates the information used as input to the machine learning algorithms developed for this task (see Section 6).

The DISCoS system and processors, which converts LV0 telemetry into LV1, was completely reused in AGILE's Ground Segment, becoming the **TMPPS** [43]: this system archives each telemetry LV0 files and sorts its packets into one stream for each layout. At each pass in Malindi, the LV0 is received at MOC, through the TCP/IP protocol, and is ingested into the SOC, where the TMPPS runs. Each stream is processed in parallel in order to unpack the various telemetry fields. Each operation is tracked into a MySQL database³ which interfaces the TMPPS pipeline to the scientific pipeline running at SOC.

³<https://www.mysql.com>

6 The third pillar: the reconstruction software and the science tools

The development of the P/L simulators has allowed the design of the P/L and also to provide the inputs for the development of many software components of the AGILE software system, in particular the AIV software. The third pillar of the operational phase is undoubtedly the reconstruction software and the Science Tools (the last one developed at INAF/IASF Milano along with some components of the reconstruction pipeline).

6.1 The reconstruction software and the machine learning

The reconstruction software (a.k.a. RECO) is compound of the standard analysis (**RECO-STD**) and the **on-ground event filter** (see Fig 5). The standard analysis has the following components:

1. COR processors, providing a timing correction of LV1 files;
2. track reconstruction algorithm, used for energy estimation and event direction reconstruction, is carried out by an AGILE-GRID specific implementation of the Kalman Filter technique [27] and provides the incident direction and the energy of the events in the AGILE-GRID reference system, that are saved in the TRK file format;
3. LOG event generator, to produce LOG files containing all the spacecraft information relevant to the computation of the effective exposure and good time interval) (GTI).

The AGILE-GRID on-ground event filter [16] assigns a classification flag to each event acquired by the GRID instrument depending on whether it is recognised as a γ -ray event (*gamma*), a charged particle (*particle*), a single-track event (*single*), or an event of uncertain classification (*limbo*). The filter is compound of two main components: the RECO-MVA that generates the information used for the classifier, and the RECO-CLS, the classifier that is based on a machine learning technique called boosted decision tree (BDT). BDT maximises the signal-to-background ratio, efficiently suppressing the background events and, in the meanwhile, keeping a high signal detection efficiency. The selection is done on a majority vote on the result of several decision trees, which are all derived from the same training sample by supplying different event weights during the training. A version using Neural Networks has been also developed. These classifiers was tuned with two samples of Monte Carlo events (generated by GAMS and converted in LV1 by DHSIM, see Fig. 6), the training sample, and then tested with an independent testing sample. The trained BDT become the on-ground event filter. Two on-ground event filters was developed: FT3ab and FM3.119, in addition to the F4 filter developed at INAF/IASF Milano and included in the FM3.119 filter. The FM3.119 is the currently used on-ground background event filter for the scientific analysis of the AGILE-GRID data. FM3.119 is an evolution of the FT3ab, where 182 descriptor parameters of the interacting event inside the AGILE-GRID has been defined, and a subset of 57 of them have been selected as the most effective input variables for optimising the event separation, also

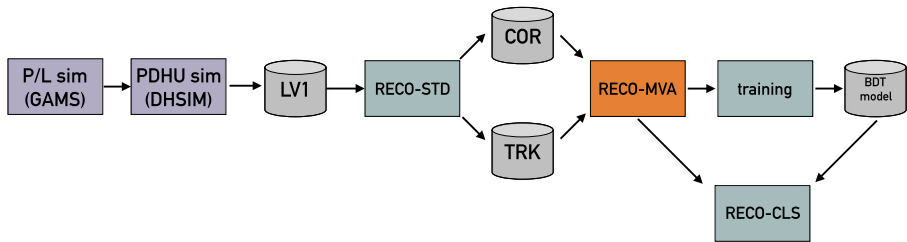

Fig. 6 The workflow of the development of the on-ground event filters. The data to perform the training with machine learning techniques are generated as Monte Carlo events with GAMS and converted in LV1 with the DHSIM. The RECO-STD prepares the data as input for the training of the BDT method. The trained BDT become the on-ground event filter. The RECO-MVA is derived from the SC-QL, and prepare the data for machine learning algorithms. RECO-CLS is the classifier that takes as input an already trained BDT model

using the previously developed F4 on-ground background event filter optimised for a good pattern recognition of a sub-class of γ -ray events.

Finally, the event direction in sky coordinates is reconstructed and reported in the AGILE event files (EVT), excluding events flagged as charged back-ground particles. The Level-2 (LV2) archive of LOG and EVT files is then produced.

6.2 The science tools

The AGILE Science Tools [19] are the tools necessary to analyse AGILE data starting from LOG and EVT files (LV2). They provide a way to generate counts, exposure and diffuse emission maps (LV3) that are used as input for the binned maximum likelihood estimator (MLE). The analysis depends on the isotropic and Galactic diffuse emission, the γ -ray photon statistics, the Instrument Response Functions (IRFs). IRFs are matrices that characterise the effective area (Aeff), the Point Spread Function (PSF), and the energy dispersion probability (EDP), that depend on the direction of the incoming γ -ray in instrument coordinates, its energy and on the on-ground event filter. The result of the MLE is an evaluation of the presence of one or more point-like sources in the sky maps [13]: this is the essential step for the scientific results of AGILE.

Table 1 reports the list of internal and publicly released Science Tools. Table 2 reports the list of internal and publicly released IRFs with compatible Science Tools. With the last version of the Science Tools AGILE_SW_6.0 a new diffuse Galactic emission model, optimised in particular for the Galactic central region, has been released. Until 2015 the concurrent version system was CVS⁴, currently a git system⁵ hosted on github.com is used and also the development version of the AGILE Science Tools is publicly available⁶.

⁴<https://savannah.nongnu.org/projects/cvs>

⁵<https://git-scm.com>

⁶<https://github.com/AGILESCIENCE/AGILE-GRID-ScienceTools-Setup>

Table 1 Science Tools releases. The first column reports the official and public version; the second column indicates the internal tag of the AGILE code repository system (report in the third column), the fourth column reports the release date and last column a short description of the main changes

Public version	Internal tag	Repository	Date	Description
AGILE_SW_3.0	BUILD18	CVS	May 21, 2009	First MLE multi-source analysis.
AGILE_SW_4.0	BUILD19	CVS	Oct 10, 2009	Performance optimisation. Bug correction.
AGILE_SW_5.0	BUILD20	CVS	Nov 22, 2011	TS map.
Internal	BUILD21	CVS	May 21, 2013	Performance optimisation. Bug correction.
Internal	BUILD22	CVS	June 25, 2015	Performance optimisation. Bug correction.
Internal	BUILD23	github.com	Dec 22, 2015	Analysis of extended sources.
Internal	BUILD24	github.com	Apr 19, 2016	Aperture photometry. Performance optimisation. Bug correction.
AGILE_SW_6.0	BUILD25	github.com	Mar 15, 2019	Performance optimisation. Wavelet analysis. GRB search. Blind search of γ -ray excesses. Multi-spectral analysis with MLE. EDP correction.

Science Tools, IRFs and Galactic emission model are publicly available from the AGILE website at SSDC⁷. A full description and characterisation of the last release of the Science Tools is available in [16].

6.3 From construction phase to operations

In the last sections we have described the approach used for the development of the AGILE software system during the construction phase. In particular, some design choice played a fundamental role: the early decision of the final data model and format, the development of the P/L simulators, the AIV software and its full reuse in the Ground Segment, the organisation of the AGILE Team during the construction phase, the reconstruction software and the Science Tools. These elements allowed the AGILE Team to have an automatic scientific data analysis system running immediately after the launch, an early version of the AGILE Real-Time Analysis (RTA), a software pipeline that analyse the AGILE data in real-time to detect γ -ray flares or GRBs from AGILE data and to react to external science alert from other instruments.

Most of these components come from the AIV software, with some additional RECO and Science Tools components, but the RTA is not just a set of software tools organised around a flexible software architecture, it is also a set of procedures, ideas and people that have allowed the AGILE Observatory to be a protagonist of the multi-messenger and multi-wavelength astronomy.

In the following sections is described how the AGILE Team has faced the continuous challenge made of fundamental scientific discoveries that caused changes in scientific scenarios and mission configuration.

⁷<http://agile.ssdsc.asi.it>

Table 2 IRF releases. The IRFs I0023 analysed in [20] are the same as I0025 but compatible with the last release of the Science Tools for energy dispersion inclusion. H0025 are equal to I0025, except for a different boundary of two energy channels: we have 100 – 400 MeV, 400 – 1000 MeV in I0023 and I0025, and 100 – 300 MeV, 300 – 1000 MeV in H0025. Earlier versions (I0007/I0010) of the PSF matrices used histograms taken directly from the Monte Carlo simulations. The updated PSF matrices contain values derived from a fit to the Monte Carlo data using a modified King function

IRF version	I0007	I0010	I0023	I0025	H0025
Public release	May 21, 2009	Internal	Nov 22, 2011	Mar 15, 2019	Mar 15, 2019
Compatible Science Tools release	AGILE_SW_3.0 AGILE_SW_4.0 AGILE_SW_5.0	AGILE_SW_3.0 AGILE_SW_4.0 AGILE_SW_5.0	AGILE_SW_3.0 AGILE_SW_4.0 AGILE_SW_5.0	AGILE_SW_6.0	AGILE_SW_6.0
PSF binned directly from MC histograms	X	X	X	–	–
PSF binned from fit to King function	–	–	X	X	X

7 The AGILE Real-Time Analysis and the transient sky

To understand the variability of the γ -ray sky is necessary to follow the sky in real-time, to notify the astrophysical community as soon as possible if something of new occurs in the sky, e.g. a new γ -ray flare. Only a coordination, also achieved through the publication of so-called Astronomer's Telegrams⁸ or notice or circulars to the Gamma-ray Coordinates Network (GCN)⁹, allows the astrophysical community to follow these phenomena when they occur, to better understand the nature and the behaviour of known and unknown astrophysical sources; this is the “observational” part of the so-called multi-wavelength and multi-messenger astronomy.

In this context, quick reaction time allow focusing on transient events detected by AGILE in the MeV-GeV energy range. Serendipity transient discoveries during the AGILE observations is possible given the large field of view and AGILE sensitivity. The search for γ -ray transients (of Galactic and extragalactic at time scales from hours to days, or Gamma-Ray Bursts (GRBs)) is one of the major activities performed by the AGILE Team, with a monitoring program active daily since the beginning of the mission, with a dedicated alert system that is implemented within the AGILE Ground Segment, distributed between SSDC and INAF/OAS Bologna and called the AGILE Real-Time Analysis (RTA).

The history of the AGILE monitoring program could be divided into two parts. The first part (2007-2015, see Section 7.1) was devoted in searching for γ -ray transients (Galactic and extragalactic) detectable on timescales of 1-2 days in the AGILE-GRID data (with a Flare Advocate team dedicated to follow the science alerts generated by the Real-Time Analysis system and to publish Astronomer's Telegrams), and to search GRBs detected by MCAL and SA (with a GRB team devoted to issue GCN notices or circulars).

The second part of this history started in 2015 (see Section 7.2), with the first direct observation of a gravitational wave, made on September 14, 2015, by the LIGO and Virgo collaborations and announced on February 11, 2016. ICECUBE experiment started to send notices via the GCN network in 2016; this has opened a new scientific context also for the AGILE Team: additional efforts have been required to move our pipelines in the context of the multi-messenger astronomy.

The first version of the AGILE Real-Time Analysis, in operation until 2016, is described in Section 7.1. The current version of the AGILE Real-Time Analysis, used in the multi-messenger context, is described in Section 7.2.

7.1 The AGILE Real-Time Analysis first version: the variable sky in the multi-wavelength context

7.1.1 The AGILE-GRID pipelines

After the launch the AGILE Team began to develop the first system of data analysis in real-time, with the various components described in the previous sections.

⁸<http://www.astronomerstelegram.org>

⁹<https://gcn.gsfc.nasa.gov>

Two automatic alert generation systems for analysing AGILE-GRID scientific data was created [15]: these systems perform the same operations as humans do, with the same software, and start whenever new data arrives, and decide if there is a γ -ray flare and then alert the team. Why two automatic analysis systems? Given the scientific importance of the sky in real-time, two groups of the AGILE Team took up the challenge and created two systems in a completely independent way. The first at the INAF/IASF Bologna (now INAF/OAS), the second at the ASDC data centre in Rome (now SSC). The two solutions were very different, even if the software components used was the same.

The first alert generation system, at INAF/OAS Bologna, called **AGILE-GRID Science Alert System** [15], maximises the speed of reaction, even at the cost of losing something on the data quality, and starts immediately as new data arrives (every 96 minutes), generating alerts in near real-time. In the Bologna's pipeline the search for candidate transient Galactic sources in daily AGILE-GRID maps is carried out with two statistical methods: (i) blind-search (the first version of the system was called SPOT4) based on counts excesses search and on the MLE multi-source analysis [13] of the Science Tools; (ii) false discovery rate (FDR) method in source detection, that selects candidate sources with an FDR of 10^{-3} [39] or less. The current version of the system is called SPOT6 and is in operation since 2016 (based on the BUILD24 of the Science Tools), with an update in 2019 (called SPOT6b) to integrate the new BUILD25 of the Science Tools (see Section 6.2).

The second alert generation system, in SSC, called **Quick-Look Scientific pipeline** [37], maximises data quality, and for this reason, it performs a more in-depth analysis, twice a day. The procedure uses a more complete data set to consolidate the data and is necessarily slower, as it is necessary to wait for the following orbit to generate an output because the data to reconstruct the last minutes of the satellite pointing direction are contained in the next orbit. After the generation of sky maps, a blind search based on counts maps and a MLE analysis runs. The results are distributed twice a day.

The two automatic alert generation systems were put into place in a few months, first in Bologna starting from September 2007 and then, shortly, in Rome at SSC. From 2008 the two systems send the results by e-mail. Although apparently it would seem a duplication of effort, from this challenge a synergy came out, with the common goal of following the sky in real-time: the two systems allow independent cross-checking, thus maximising the scientific return of AGILE. Once an alert has been generated, the Flare Advocate team works to confirm the results before publishing an Astronomer's Telegram. Having two different alert generation systems running in two different locations allows the AGILE Team to have a geographically distributed system to increase the availability if one of the two sites goes off-line.

At the start of the new automatic AGILE-GRID Science Alert System in Bologna, in September 2007 automated science alerts were generated from the Crab nebula region: a γ -ray flare from the Crab Nebula was detected for the first time. Seeing a variable behaviour from this source was so strange that the only possible hypothesis was that the new automatic system was wrong. The team spent a lot of time checking the automated system but finding nothing. The system restarted, leaving this doubt open, but in the 1AGL Catalog [36] it was pointed out that the average flow of the

Crab Nebula was higher than expected. Even if not publicly announced, this is the first detection of a γ -ray flare from the Crab Nebula ever seen.

In the second half of 2008 to the Bologna system was added the possibility to send alerts via text messages (SMS) on the mobile phones (see Fig. 8) (in those days, smartphones did not yet exist).

Since 2007 the two AGILE-GRID pipelines are working without interruption. Almost every week new possible γ -ray flares are found. Throughout 12 years of activity (at the time of writing), more than 140 astronomical telegrams have been published, but cross-checks have been made on alerts at least 4-5 times higher.

The response time of the system was fundamental. The generation of alerts in 30-50 minutes after the ground contact is an absolute record for γ -ray missions of this type. All this is possible thanks to the flexibility of the AGILE Ground Segment. Figure 7 shows the transfer time of the Ground Segment from the AGILE satellite to science alerts to mobile phones and to the AGILEScience App. This data transfer time is the result of an optimisation of the data flow performed by SSCD in 2016. Before this optimisation, the response time was around 110-150 minutes.

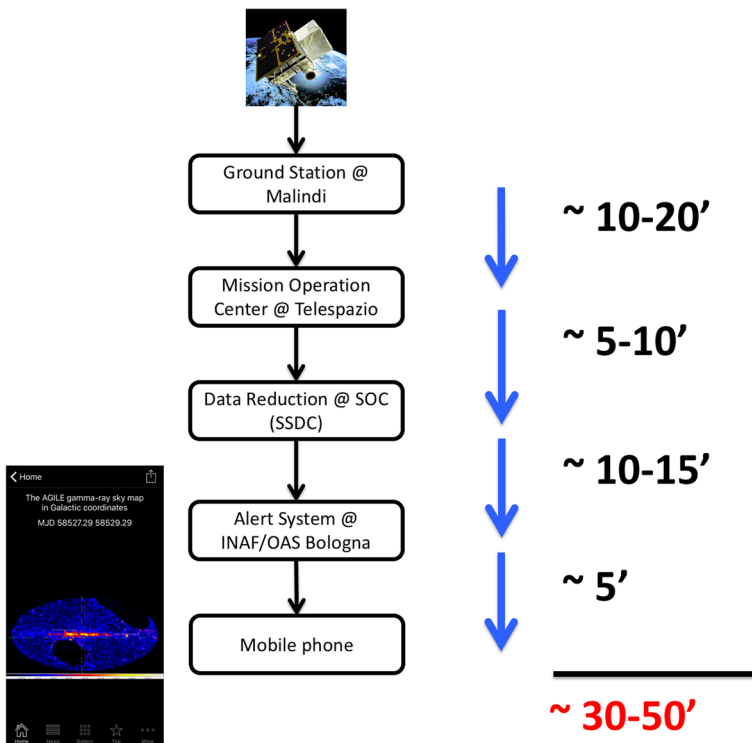

Fig. 7 Data transfer time of the Ground Segment from the AGILE satellite to science alerts to mobile phones and to the AGILEScience App

7.1.2 The Flare Advocate team and the App AGILEscience: science on the road

The introduction of smartphones and tablets (the first iPad was presented in 2010) quickly changed the approach to mobile technologies. The interactivity allowed by these technologies makes it possible to move some of the activities carried out by the Flare Advocates to mobile devices. In 2009 we added the possibility to see the γ -ray sky maps in real-time on smartphones, allowing scientists to have an immediate view of what is happening in the sky.

However, the big step to the AGILE Team to mobile computing was in 2011: we decided to develop the **AGILEScience App** for Apple^{10, 11} and Android¹² mobile platforms, thanks also to the help of the University of Modena and Reggio Emilia. The App¹³ not only provides information, photos, videos and updates on the AGILE mission, but the primary purpose was to give all astronomy enthusiasts the chance to follow the γ -ray sky in real-time; the App shows the γ -ray sky map of our Universe as seen by AGILE-GRID, and updated every orbit. The Flare Advocates also use this feature. To achieve this goal, the App has been connected to the Bologna AGILE-GRID Science Alert System and subsequently, in 2013, to the SSCD system for data quality checks.

In 2014 our App allowed the astronomy enthusiasts to follow, for the first time, the evolution of the 3C54.3's super-flare through push notifications (see Fig. 8).

In 2015 we added a unique feature among all high-energy instrument: the possibility to perform a full scientific analysis with real-time data using only the App. This allows the Flare Advocate team to perform what we call, "science on the road", i.e. possibility to check the results of the AGILE-GRID Science Alert System, the possibility to receive important science alert via push notification, and finally, the possibility to perform a scientific analysis for the confirmation of the results before publishing an Astronomer's Telegram, everything using only the App (see Fig. 9). This significantly increased the reaction time of the AGILE Team in the context of the multi-wavelength astronomy.

7.1.3 The AGILE GRB WebMon: GRID, MCAL and SA GRB alert pipelines

The AGILE-GRID Science Alert System pipeline was not alone. Other three pipeline focused on GRB detection was developed and integrated into a unique web interface [11, 45]:

1. the **SuperAGILE (SA) Alert Pipeline** runs at INAF/IASF Roma to search for GRBs, X-ray bursts and other transients in the hard X-ray band [24]. The SuperAGILE ground software is equipped with a ground trigger running on timescales from 512 *ms* up to 16384 *ms* using the scientific ratemeters and taking advantage of the segmentation of the SuperAGILE detector. A weak-up system is also

¹⁰<https://itunes.apple.com/it/app/agilescience/id587328264?mt=8>

¹¹<https://itunes.apple.com/it/app/agilescience-for-ipad/id690462286?mt=8>

¹²<https://play.google.com/store/apps/details?id=com.agile.science>

¹³<http://www.agilescienceapp.it/wp/agilescienceen/>

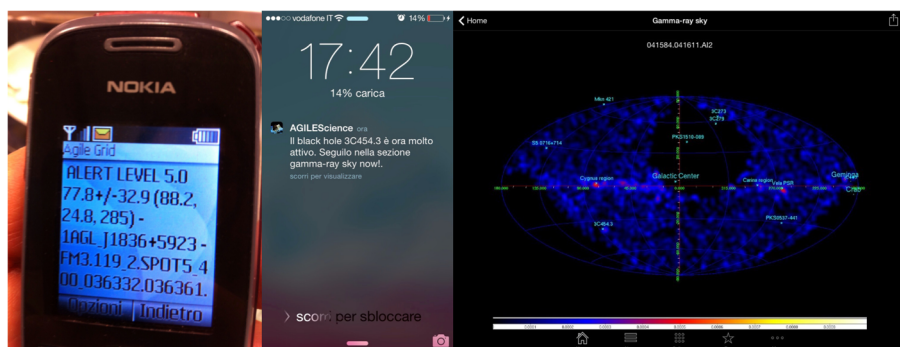

Fig. 8 From text messages (SMS) to push notifications and to γ -ray sky maps on the tablets and Apps. Over the last few years, mobile technology has evolved and has changed the way we work and live. This evolution has been used to maximise the scientific return of AGILE

- present to alert the SA team if a GRB was found. The system was able to generate GCN notices ¹⁴ ;
2. the **MCAL Alert Pipeline** [32, 33] runs at INAF/IASF Bologna processes the data of the MCAL burst chain in order to identify valid burst on-board triggers and to search for both cosmic GRBs and valid Terrestrial Gamma-ray Flashes (TGF) candidates. For every trigger detected by the onboard logic the event data are analysed to exclude instrumental triggers. Information on all on-board triggers is stored in a database that can be accessed from the Web for monitoring. In addition, on contact by contact basis, a ground trigger algorithm runs on scientific ratemeters to notify via e-mail the MCAL team for transients not recognised by the on-board logic;
 3. a **dispatcher** task handles the Swift/BAT, INTEGRAL/IBIS, and Fermi/GBM Notices received from the GCN through a TCP/IP Internet socket and the GRB alerts generated via e-mail by the above SA and MCAL Pipelines. These results are sent to the GRID GRB pipeline;
 4. the **GRID GRB pipeline**: in case the GRB is localised inside the GRID Field of view (FoV) by external instruments or by MCAL and SA, this task runs automated analysis in order to search for detection or provide an upper limit (UL) on the flux. The analysis results are e-mailed to the AGILE Team. The GRID GRB Pipeline performs the GRB search in the AGILE data by comparing the expected background with the counts in the first 60 s, in a region of 15° of radius centred at the position of the burst.

The AGILE P/L Health Monitoring (see [11] for more details), already introduced in Section 5.1 is integrated into the same web interface with the MCAL and GRID GRB pipelines.

MCAL, SA and GRID GRB pipelines alerts the AGILE Team via e-mail and via SMS to mobile phones if transients or burst where detected. The system was

¹⁴https://gcn.gsfc.nasa.gov/agile_grbs.html

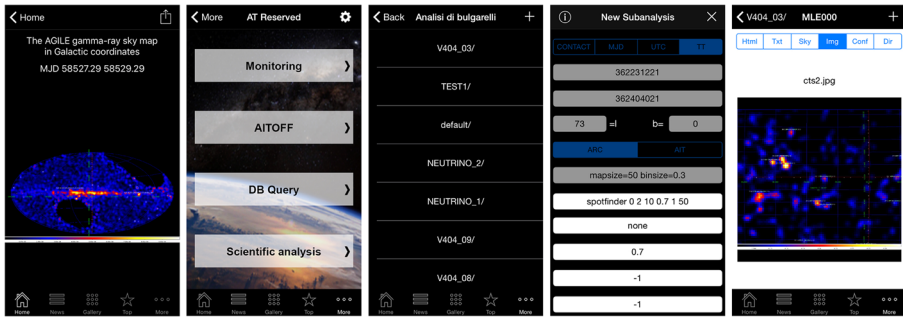

Fig. 9 “Science on the road” with the AGILEScience App. From left to right: (i) the Flare Advocate can check the γ -ray sky. If a candidate γ -ray flare is found it is possible to perform a manual scientific analysis to confirm the result. To perform the scientific analysis, (ii) the Flare Advocate goes in the “Scientific Analysis” section, (iii) where is possible to create a new analysis or select an existing one, (iv) some parameters of the analysis must be inserted (e.g. integration time, position in the sky), and (v) the App shows the final result, analysed with the Maximum Likelihood Estimator, and the sky maps

distributed among the SOC at SSDC, and the AGILE Team Quick Look sites, located at INAF/OAS Bologna (P/L Health monitoring, MCAL and GRID GRB pipelines) and INAF/IASF Roma (SA pipelines).

The AGILE-GRID pipelines, the AGILE GRB WebMon, the P/L Health monitoring and the App AGILEScience was the first version of the AGILE Real-Time Analysis. Figure 10 shows the workflow and the general architecture of the pipelines.

7.1.4 The spinning mode: a new life for the AGILE observatory

October 18, 2009. One of the subsystems on board the AGILE spacecraft, the rotation wheel, suffered a malfunction that caused the satellite to leave its nominal pointing mode and switch to the spinning control mode. The spinning control mode guarantees the safety of the Spacecraft and the Payload. The work performed by the AGILE Team and by the space industries involved in AGILE to reconfigure the space mission was very difficult, but after some weeks, on November 4, 2009, at 12:25:54 the AGILE scientific operations restarted. From that day the instrument is operating nominally, and all detectors are on and acquiring data. The satellite is working in a safe spinning mode, with the fixed solar panels pointing towards the Sun and the GRID instrument FOV covering about 70% of the sky in one day. The satellite scans the sky with an angular velocity of about 0.8° s^{-1}

The reorganisation of the on-ground software continued in the following months, and some GRB WebMon pipelines were switched off because it was no more possible to follow GRB with a rotating P/L.

However, it is thanks to this new configuration that the most important discoveries of AGILE-GRID in the field of multi-wavelength astronomy have been possible. The most important γ -ray flare in the AGILE history was the Crab Nebula flare of September 2010. When the morning of September 21st we begin to receive SMS

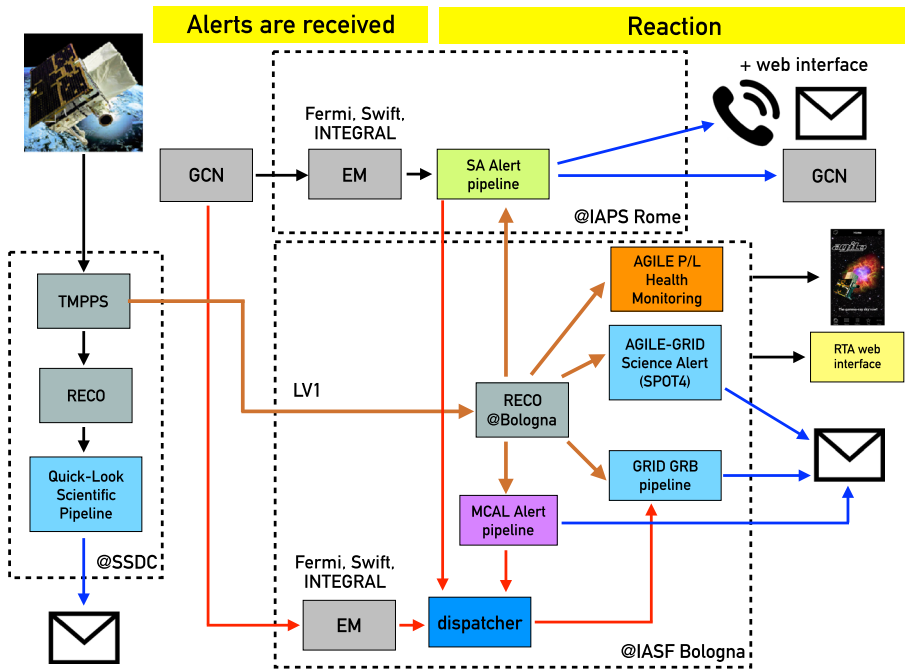

Fig. 10 The first version of the AGILE Real-Time Analysis workflow at INAF/OAS Bologna (formerly INAF/IASF), INAF/IAPS Rome and SSDC, in operation until 2016, with the LV1 data received from SSDC. Alerts are received from the GCN network. The AGILE-GRID Science Alert System (SPOT4) the AGILE-MCAL and SA Alert pipelines analyze new data as soon as is processed by RECO-STD, that perform the reconstruction of the data. The AGILE-GRID GRB pipeline reacts if there are GRBs notified by the GCN network or detected by SA and MCAL pipelines (via the dispatcher). A web GUI and the AGILEScience App show the results of some automated processing. Alerts are sent by email to the AGILE Team. The SA Alert pipelines run at INAF/IAPS Rome and has a wake-up system and was able to generate GCN notices

and e-mails with a flare positionally consistent with the Crab region, we took the matter seriously, reminding the September 2007 event. That day the whole AGILE Team was in a meeting in Rome, so we were all out of the office. The γ -ray flux of the Crab Nebula was progressively increasing (following the sequence of alerts that were coming from the AGILE-GRID Science Alert System). This is one of those cases where “mobile” technology has played a fundamental role: we followed the evolution of the phenomenon on our smartphones and checked the γ -ray sky maps in real-time. During the meeting, some of us started to work on the data, and after the necessary cross-checks an Astronomer’s Telegram was published [41]. After a few hours, the NASA Fermi satellite confirmed the results [7]. For this discovery Marco Tavani and the AGILE Team was awarded 2012 the Bruno Rossi Prize of the American Astronomical Society (AAS). Figure 11 shows the sequence of events of the 2010’s Crab Nebula flare.

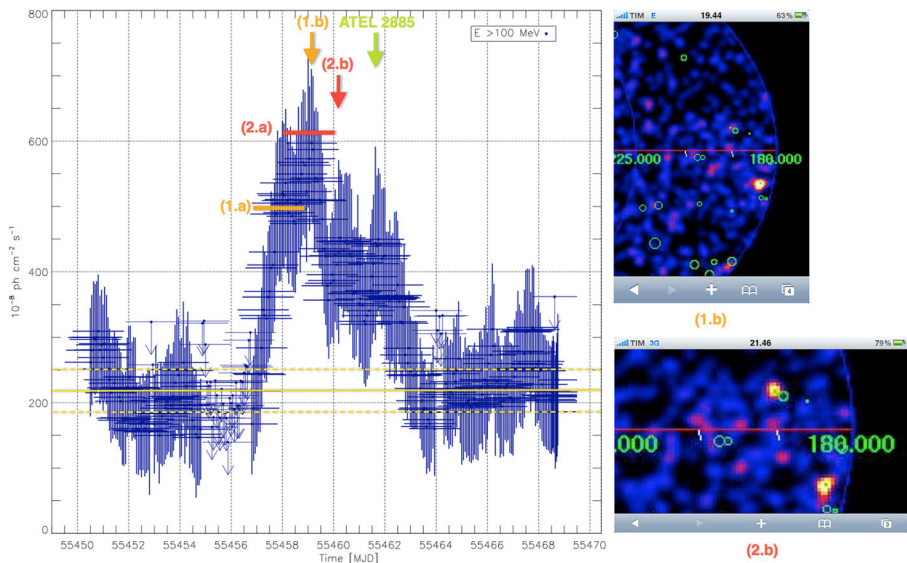

Fig. 11 96' sliding light curve (with two-day integration time) of the 2010 September Crab nebula flare as seen by the Bologna's AGILE-GRID Science Alert System. Errors are 1σ , and time is given in MJD. The yellow lines show the average Crab flux and the 3σ uncertainty range. 1.a and 1.b (in orange) are, respectively, the detected flux and the time of the alert generation by the Bologna pipeline when Crab nebula reaches a flux level that exceeds 1σ the mean flux level; on the right are the counts map of 1.b as seen by Bologna pipeline. 2.a and 2.b (in red) are related to the maximum flux level reached; on the right are the counts map of 2.b as seen by Bologna pipeline. The green arrow indicates the time that the Astronomer's Telegram was posted. More details in [15]

7.1.5 Data Warehouse for scientific discoveries: business logic for science

Until 2012 the main focus of the software developers was the optimisation of the AGILE-GRID Science Alert System pipeline. Five years of results were available, and the access to this large amount of data was a problem.

New questions emerged: was it possible to archive the detection and scientific alerts generated by these systems and make them accessible for historical analysis? Was it possible to generate science alerts from a γ -ray source, taking into account the history of the source? To answer these questions, the most natural evolution was to apply standard techniques of the enterprise world, such as Data Warehouses, to the scientific context. To manage the large amount of data and result generated by the AGILE-GRID Science Alert System, a new system was and put in operation in 2015, called **AGILE-GRID Data Warehouse System**.

In computing, a data warehouse (DWH) is a software system used for reporting and data analysis and is considered a core component of a decision support system. DWHs are central repositories of integrated data from one or more disparate sources. They archive current and historical data in one single place that are used for creating analytical reports. The primary input is a *User Database*, that is the input to build the *Operational Database*, a database designed to integrate data from multiple sources

for cleaning, to ensure data quality before it is used in the DWH for reporting, and additional operations on the data (e.g. to discover relationship into the data). The integrated data of the operational database could be transformed to another database, the *Data Warehouse Database*, where the information is arranged into hierarchical groups (called dimensions, facts and aggregate facts) for a fast generation of the final reports.

This system ingests and clean the results of the AGILE-GRID Science Alert System in a MySQL server. For each detection, various information is stored in the User Database, to allow researchers to study the astrophysical phenomenon in real-time but also to carry out historical analyses. After being stored in the User Database, the data is aggregated and inserted into the Operational Database (i.e. the database feeds with the data contained in the User Database) following a different scheme that enables the aggregation of detections into light curves (starting from the last detection imported into the User Database) allowing the correlation of the current detection with the historical data and enabling the identification of a science alert associated with a light curve: in this way a science alert is no longer a single detection above a certain threshold of significance, but becomes a complex system of heuristic rules that also take into account the historical evolution of the source and the region of the sky: a science alert is a concept built on top of a set of correlated detections.

An additional level of integration for sky regions and time has also been developed for the AGILE-GRID Data Warehouse System. It is of fundamental importance to reduce the computation time of the queries performed on a large amount of data and to do so we must rely on the specially designed Data Warehouse Database, where a higher level of aggregation is precomputed. The facts that have been chosen are a time aggregation level (by day, week, month or years) and a sky region aggregation level (using circular regions (called rings) centred on points defined by HEALPix (Hierarchical Equal Area isoLatitude Pixelisation) [28] tessellation with N_{side} 32, 64 or 128).

A reporting system called “Dashboard” was also developed. A Dashboard is a tool that usually allows to quickly view the essential information of a process or of the key performance indicators (KPIs), on dimensions useful for decision makers. In the scientific context, the KPIs are the trend of astrophysical sources, the significance of detection, a full view of the sky, the behaviour of some regions of the sky for historical analysis. With this tool, researchers can access the data contained both in the database and through their mobile devices, integrating this tool in their daily research activities. Figures 12 and 13 report an example of the use of Data Warehouse.

7.2 The AGILE Real-Time Analysis second version: the multi-messenger astronomy

With the first direct observation of a gravitational wave (GW) announced by the LIGO/Virgo collaboration, the era of the multi-messenger astronomy entered into a new phase and marked the onset of gravitational-wave astronomy [5]. On August 17, 2017, the first gravitational wave event GW170817 observed with an electromagnetic counterpart marking a significant breakthrough for multi-messenger astronomy. The next step happened on September 22, 2017, when an extremely high-energy neutrino

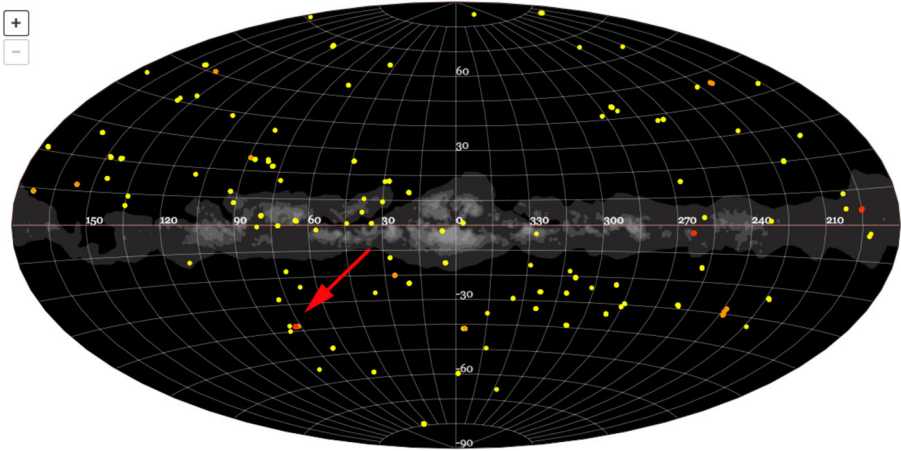

Fig. 12 An example of the use of the AGILE DWH. The first report is the interactive sky map of the last N hours (in the example, $N=48$), where each yellow or orange dots represent a detection (yellow, with detections in the range $3 - 4\sigma$ or orange, with detections in the range $4 - 5\sigma$, red dots are science alerts. In this example of Nov 11, 2016, we can see that the science alert come from Galactic coordinates $(l,b) = (77.4, -38.4)$, associated with the source CTA 102

event (IceCube-170922A) was recorded by the IceCube Collaboration which sent out an alert that prompted an extensive multi-wavelength campaign [1].

A vital feature of the AGILE Observatory was the spinning mode configuration, described in Section 7.1.4. Thanks to this observing mode the capability of the AGILE satellite for the discovery of transients is unique: the actual spinning configuration of the satellite, together with a large field of view and a good sensitivity provides coverage of 70% of the sky, with each position exposed for 100 seconds, 200 times a day. Thanks to this configuration, it immediately became evident that

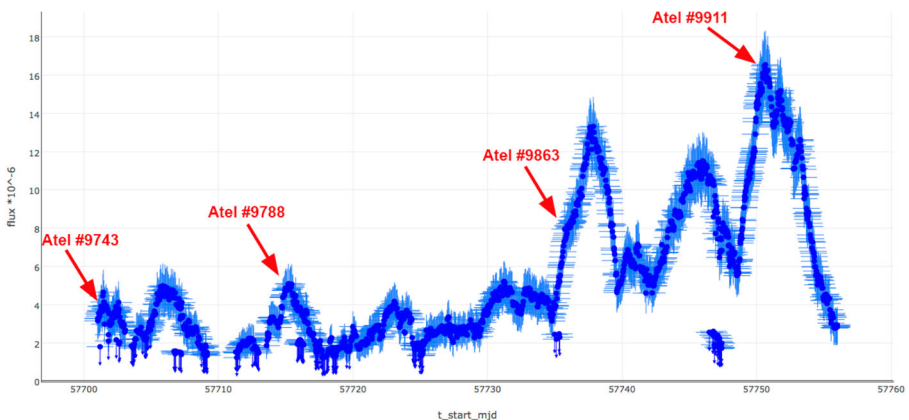

Fig. 13 An example of the use of the DWH. The second report shows the light curve associated with the science alerts generated by the CTA 102 position. Four of Astronomer's Telegrams have been published

AGILE plays an important role in search of the γ -ray electromagnetic counterparts of gravitational waves, so the AGILE Team decided to evolve the AGILE Real-Time Analysis in a second version, to react to external GW or neutrino alerts.

To reorganise the AGILE pipelines, taking into account the new scientific requirements, the first step was a definition of the use cases and the workflow of the whole system, and connected with this a risk analysis was performed. Based on this analysis, and considering the existing software architecture, the software components that could be reused were selected, other parts refactored, and others developed from scratch. To speed up the process the team adopted a development method based on Scrum, applying DevOps principles¹⁵, and using an automation server¹⁶ and a release management process based on containers¹⁷. The code is publicly available on the GitHub platform¹⁸.

After some months of intense development, the second version of the AGILE Real-Time Analysis with an automated search of γ -ray electromagnetic counterparts of a GW was ready in October 2016, just before the start of the O2 LIGO/Virgo run.

7.2.1 The software architecture

The software system RECO, running in SSDC has been optimised to reduce the processing time. Also thanks to this effort, the time needed to send the data to Bologna was further reduced, up to the 30-50 minutes. The Science Tools have been subjected to an intense refactoring to speed up the analysis and to add new features. The BUILD25 is the current official release (see Section 6.2).

The parts left unchanged are the TMPPS, the P/L Health Monitoring system and the AGILE-GRID Science Alert System: this because the AGILE-GRID Science Alert System does not react to external science alerts but looks for γ -ray flares when new data is available.

The components that were developed from scratch was the management of external science alerts (which replaced the dispatcher described in Section 7.1.3), to include also the LIGO/Virgo alerts (the **gcndaemon**), a two new wake-up systems (**morfeo** and **hermes**) that call the team when a GW alert is received [47], and a completely new and flexible system (called **rta-sci**) for the management of scientific analyses that perform scientific tasks automatically as soon as the data is available and in response to external alerts. A pipeline manager orchestrates the workflow, and the analyses are submitted to a job scheduler (slurm¹⁹) and stored in a database (MySQL). New analysis can be easily added thanks to this architecture.

Thanks to this new development the old GRID and MCAL GRB Alert Pipeline systems have been redeveloped, and integrated into the rta-sci system. The SA GRB Alert Pipeline system is currently used in manual mode.

¹⁵<https://en.wikipedia.org/wiki/DevOps>

¹⁶<https://jenkins.io>

¹⁷<https://www.sylabs.io/>

¹⁸<https://github.com/AGILESCIENCE/> and <https://github.com/rta-pipe>

¹⁹<https://slurm.schedmd.com/>

In addition to the reaction the external science alerts, a new MCAL pipeline (**AGILE-MCAL pipeline**) that searches for GRB and TGF in MCAL data has been developed and integrated into the rta-sci. In the presence of a GRB identified by MCAL an automated GCN notice is submitted²⁰, also taking into account any notice received in the meantime by other satellites.

A sketch of the workflow is shown in Fig. 14.

A control room web page shows the status of the data acquisition, the delay on the data flow and some information about the data quality (provided by SSCDC) and is used by the AGILE Team to evaluate the delay of the data with respect to a GRB/neutrino/Gravitational Wave events.

In this effort, the Graphical User Interface (GUI) has been updated with new web technologies, allowing access to the results of automatic processing. Also the AGILEScience App has been connected with the rta-sci system.

7.2.2 AGILE-GRID GRB and MCAL Pipeline

The AGILE-GRID GRB and MCAL pipelines react when new GRBs, neutrinos or LIGO/Virgo events are notified through the GCN network, and a set of automated analysis on AGILE-GRID and MCAL data starts as soon as data are available. Also an MCAL GRB detection can trigger the pipelines of the AGILE Real-Time Analysis. A visibility prevision plot is produced immediately and shows the prevision of the position of the Earth and the Sun with respect to the localisation error region in a sky map in AITOFF projection and, as soon as the data is available, also a final visibility plot with real data is generated. In this final visibility plot, provided by SSCDC, the field of view of AGILE-GRID and AGILE-SA is overlapped with the error localisation region.

A burst search algorithm on MCAL data runs on the following time windows: 5, 10, 100 and 1000s to find possible GRBs. On GRID data a burst search method that uses an algorithm reported in [30] is performed to find candidate γ -ray emission in the energy range 50 MeV-10 GeV with the following time scales: 2, 5, 10 and 100 s. In parallel, counts and exposure maps on GRID data are produced with the same time scales, with overlapped the localisation error region. Automated evaluation of the AGILE-GRID and MCAL upper limits inside the localisation error region is performed.

Finally, the text of the MCAL and GRID circulars is automatically produced and is checked by the AGILE Team before its publication as GCN Circulars.

7.2.3 Advocate team management

The software is only one aspect of the AGILE monitoring program. Effective management of the AGILE Flare and GW Advocate teams is mandatory. Key elements are:

²⁰https://gcn.gsfc.nasa.gov/agile_mcal.html

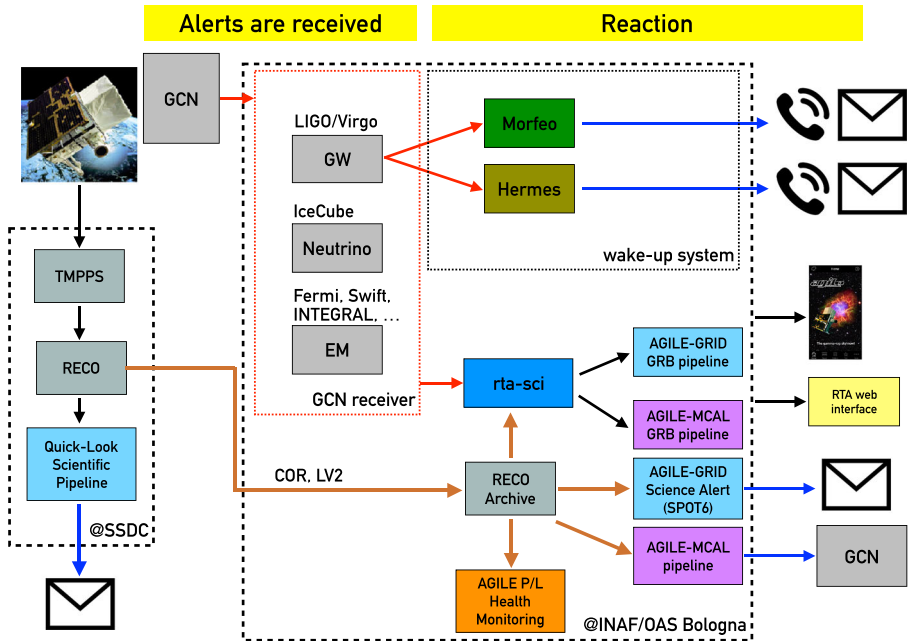

Fig. 14 The second version of the AGILE Real-Time Analysis workflow at INAF/OAS Bologna, with the LV2 data received from SSCD. Alerts are received from the GCN network. Two independent wake-up systems call the AGILE Team if a new alert from LIGO/Virgo collaboration is received. If new alerts and/or data are received, the rta-sci performs the required scientific analysis. The GRID, MCAL and SA GRB Alert pipeline react to external science alerts. The AGILE-GRID Science Alert System (SPOT6) and the AGILE-MCAL pipelines process new data as soon as is received from SSCD, that perform the reconstruction of the data. In the presence of a GRB identified by MCAL pipeline, an automated GCN notice is submitted to the GCN network. A web GUI and the AGILEScience App show the results of the automated processing. A backup of the AGILE RTA is also running in SSCD

1. **people**, on-duty and on-call that understand what they are doing and can analyse and understand the result of the automated pipelines and to perform manual analysis effectively;
2. **data**, in the shortest time and with the best data quality;
3. **procedures**, to understand what the advocate teams have to do and when, and a clear chain of responsibilities to publish scientific results;
4. **software**, of course, in particular, an effective Real-Time Analysis system with a high degree of availability, a clear and simple Graphical User Interface, and a high degree of flexibility to add or change the scientific analysis performed in an automated way.

An extended and in-depth definition of the procedure was performed before the development of the AGILE Real-Time Analysis pipelines and included in the software architecture; this has increased the effectiveness of the entire system.

8 Lesson learned

We report some lesson learned that could help the development of new data acquisition and analysis systems for both space and ground observatories. The following list is not ordered in any way, but only a collection of lessons learned from our experience, ranging from software management to team management and to data analysis.

1. define the data format and structure at the beginning of the project. Software changes and evolves, but the definition of the data format allows the project to be able to access and analyse the data acquired in any phase of the project, from AIV to scientific operations.
2. develop P/L simulators at the beginning of the project: this is a fundamental aspect of the entire project, that enable other developer and science teams to have inputs for their work at the beginning of the project; keep the simulators updated and under configuration control;
3. new ideas, new algorithms, new methods? The PI must support and be flexible enough to let people propose and try new solutions;
4. it is essential for all team members to have a general view of the Observatory operations; this generates positive feedbacks that increase the knowledge of the Observatory.
5. Do not use software tools as a black box: senior scientists must be available to transfer the knowledge to young scientists, to avoid that fundamental knowledge is lost; this is particularly important for γ -ray Observatories, where operations last decades. Black box tools do not allow the scientist to develop a critical feeling of the results they are achieving.
6. think your software architecture at the beginning of the development process. Software architecture must be organised around loosely coupled software components with standard and simple interfaces; this will maximise the software reuse and save time and money. For new projects, consider microservice architecture.
7. organise your software architecture around simple software components with well defined and standard interfaces;
8. perform a risk analysis before and during the definition of the software architecture, to identify single point failures in the data flow and in the workflow. Identify possible corrective actions and include them in the software architecture. Clarify also the quality and non-functional requirements of each software sub-system. Clarify and keep under configuration control interfaces with the external world;
9. the software architecture must be driven by use cases and by the workflow of the science team that will use the systems. Clarify with the science team this workflow: pipelines and the science team work in strict connection. The glue is the workflow.
10. put additional efforts to develop a core system highly configurable but with a robust logical model behind: this will help to adapt your system to changing conditions imposed by new scientific discoveries (this happens much more

- frequently than one can expect) or to include new algorithms during the construction phase;
11. keep the software architecture updated in each phase of the project. New requirements can be added in each phase of the project. A growing set of additional requirements comes from AIV, commissioning, and scientific operations, but also from new scientific discoveries: this could have a significant impact on the software system. Living software architecture is the only way to keep the entire system under control. Use expert software architects to keep the architecture updated: this will help maintenance activities.
 12. uses simple technologies for the core system. C++, FITS files, a scripting language as a glue, and relational databases are the key technologies that have allowed the AGILE software to survive for almost 20 years, with a limited maintenance effort. Provide also a simple abstraction for resource management and job scheduler tools and do not use specific features of them: this allows us to change these supporting tools with the evolution of the technology.
 13. the Graphical User Interfaces evolve with time, and new interactive technologies are continuously released on the market: consider to redevelop the GUI every 4–6 years on top of the existing core system, to increase the interaction with your systems thanks to new technologies.
 14. use DevOps principle when possible. As a minimum, keep your code and the production environment under configuration control. Reproducibility of the results (of a test during the AIV, of a simulation or a scientific result) is a vital aspect of a scientific project. Put in place an effective release management process and organise your development, staging and production environments. Deliver small portions of software more often continuously and incrementally; add small changes in a big system and test it. The continuous delivery also provides a developer team to continuous feedbacks from scientists.
 15. People leave the project. Keep your code in a shared and common repository and with an excellent version-control system for tracking changes in source code, and effectively manage releases. The AGILE Team has always been lucky, because all the developers who left the project have always continued to work with us, maybe in the evening or on weekends, especially in the most critical moments of the project. This because all people that have worked for AGILE have shared the challenge to build an Observatory from scratch and have shared this long but very productive journey, with mutual respect at all levels and for the different roles covered by each of us.

9 The future

In addition to the list of the lesson learned, the software tools developed by the AGILE Team can be reused for current and future γ -ray Observatories. In some cases, AGILE data has been used for the validation of new software tools for future γ -ray experiments.

9.1 The AIV software

The AIV software, described in Section 5 has been reused for other projects, in particular, the DISCoS system and the SC-QL: ASTRI project [22] and Euclid mission [44] are already two projects that reuse the entire system. However, also some general purpose libraries can be reused, e.g. the PacketLib²¹, a C++ open-source software library for writing applications which deal with satellite telemetry source packets [8].

9.2 The AGILE tools for new γ -ray space missions

9.2.1 The new P/L simulator: BoGEMMS

The BoGEMMS framework (Bologna Geant4 Multi-Mission Simulator) developed in Geant 4 and used for the simulation of X-ray space telescopes [14] has been extended for the simulation of a γ -ray space mission, to work as a common, multi-purpose framework for the present and future electron tracking γ -ray space telescopes [25]. The γ -ray extension involves the Geant4 mass model, the physics list and, more important, the production and treatment of the simulation output. From the user point of view, the simulation set-up follows a tree structure, with the main level being the selection of the simulation framework (the general space telescope application) and the secondary levels being the detailed configuration of the geometry and the output format. The BoGEMMS application has been used for the new generation of γ -ray telescopes like Gamma-Light [34], GAMMA-400 and ASTROGAM [23].

9.2.2 New energy estimation and event direction reconstruction algorithms

The Kalman filtering technique described in Section 6 used for energy estimation and event direction reconstruction is evolving in a new algorithm, a Bayesian tracking algorithm for γ -ray events. In the current and future space missions, γ -ray detection is based on pair production effects inside a tracker made of a stack of silicon strips. Improving the accuracy in reconstructing of both the direction and the energy of the original photon is crucial to fully exploitation of γ -ray telescopes. Bayesian filtering can be used to this aim because of its recursive structure that enables to keep multiple hypotheses about existing tracks and implement statistically meaningful measurement selection and matching among different planes of the tracker. The algorithm has been validated on AGILE data and then used to investigate the performances of the ASTROGAM detector and is ready for future γ -ray space telescope proposals.

9.3 Deep learning

Deep Learning is part of a broader family of machine learning methods based on learning data representations; this is an evolution of the classical machine learning approach used for the development of the AGILE on-ground event filter described in Section 6.1.

²¹<https://github.com/ASTRO-BO/PacketLib>

A Deep Neural Network approach has been used for the detection of GRBs notified by external instruments in the AGILE-GRID energy range when time and position of the GRB is known in advance, i.e. notified by an external science alert. A Convolutional Neural Network (CNN), a particular class of Deep Neural Network (DNN) used to analyse and classify images has been applied; these networks have a multiple-layer architecture where each layer is used to identify a specific feature inside the image. The CNN approach requires training of the network using large dataset. The dataset has been prepared to simulate sky maps with the AGILE Science Tools. For the preparation of this dataset, we are taking into account the complex observation pattern of AGILE during the so-called “spinning-mode” phase also evaluating a mean level of background and exposure. Convolving this observing pattern with a GRB model extrapolated from the Fermi-LAT GRB catalogue [6], we defined a GRB model used to simulate the training and the test datasets of the CNN. We evaluated the trained CNN in different observing condition by varying the background and the exposure level at the GRB trigger time. We calculated a p-value distribution of the trained CNN for each of these conditions. The p-value is used as a threshold to obtain the CNN detection significance. Finally, CNN has been tested on real GRBs and compared with the method described in [30] and currently used by the AGILE Team. The comparison with the classical approach is done using the same time window for the signal and for the evaluation of the background that is used for the CNN to select the right p-value. The CNN can detect new GRBs with different observing and background conditions, proving the flexibility of the method. The training of a CNN requires few hours, but the training is performed only one time and the trained network can work also in different observation and background conditions.

9.4 The Real-Time analysis for new γ -ray observatories

Our Real-Time Analysis pipelines process the AGILE data and react to external and internal science alerts in a fully automated way; the AGILE Flare and GW Advocate teams are interacting every day with this system, and are using the mobile computing to do “science on the road”. This experience and the entire infrastructure of this system can be moved in other projects, like the CTA Real-Time Analysis system [2].

10 Conclusion

Working for AGILE has been a unique experience to “experiment” new technologies, an experience for some AGILE Team members lasted almost 20 years. The flexibility of the Ground Segment and the pipelines played a fundamental role for the success of the mission, thanks also to a flexible software architecture where the data flow and the team workflow have worked in an integrated way. During this time we have found a synergy between astrophysics and technology to maximise the scientific return of the mission, and we think that this has also made the difference for a space mission like AGILE. In these 20 years technology has evolved and has changed the way we work and live, γ -ray astrophysics has made important discoveries and in this AGILE has played a fundamental role.

The experience gained by the AGILE Team in flexible software architecture, effective software management workflow, algorithms (from payload simulators to reconstruction algorithms to detection algorithms for Real-Time Analysis systems and follow-up of science alerts) and team management is the basis for the involvement in new γ -ray experiments and projects. However, the most important part is not only software tools but in the lesson learned and experience that allow the AGILE Team members to play an important role also in the γ -ray astrophysics of the future.

References

1. Aartsen, M. et al.: Multimessenger observations of a flaring blazar coincident with high-energy neutrino IceCube-170922A. *Science* **361**(6398) (2018)
2. Acharya, B.S., et al.: arXiv:1709.07997 (2018)
3. Argan, A., et al.: The data handling system for the AGILE satellite. In: Science Symposium Conference Record, Vol. 375, pp 371–375. NSSMIC IEEE (2004)
4. Barbiellini, G., Bordignon, G., Fedel, G., et al.: In: American Institute of Physics Conference Series, Vol. 587, Gamma 2001: Gamma-Ray Astrophysics, ed. S. Ritz, N. Gehrels, & C. R. Shrader, 754 (2001)
5. Branchesi, M.: Multi-messenger astronomy: gravitational waves, neutrinos, photons, and cosmic rays. *J. Phys.: Conf. Ser.* **718**, 022004 (2016)
6. Bhat, P. et al.: The third Fermi GBM gamma-ray burst catalog: the first six years. *ApJS* **223**, 2 (2016)
7. Buehler, L. et al.: Fermi LAT confirmation of enhanced gamma-ray emission from the Crab Nebula region, The Astronomers Telegram, 2861 (2010)
8. Bulgarelli, A., Gianotti, F., Trifoglio, M.: PacketLib: a C++ library for scientific satellite telemetry applications. In: Payne HE, Jedrzejewski RI, Hook RN (eds.) *Astronomical data analysis software and systems XII ASP Conference Series*, vol. 295, p. 473 (2003)
9. Bulgarelli, A., Gianotti, F., et al.: The MCAL science console software for the minicalorimeter of the AGILE mission. *Proc. of SPIE*, 5488 (2004)
10. Bulgarelli, A., Gianotti, F., et al.: The AIV quick look and health monitoring system of the AGILE payload. *Proc. SPIE* **7011**, 70113C (2008)
11. Bulgarelli, A., Gianotti, F., et al.: AGILE WebMon: monitoring the AGILE payload through the WEB. In: Proceedings IEEE nuclear science symposium conference, 19–25 Oct. 2008, pp 2153–2158 (2008). <https://doi.org/10.1109/NSSMIC.2008.4774778>
12. Bulgarelli, A. et al.: The AGILE silicon tracker: Pre-launch and in-flight configuration. *NIM A* **614**, 213–226 (2010)
13. Bulgarelli, A., Chen, A.W., et al.: Evaluating the maximum likelihood method for detecting short-term variability of AGILE gamma-ray sources. *Astron Astrophys* **540**, A79 (2012). <https://doi.org/10.1051/0004-6361/201118023>
14. Bulgarelli, A., Fioretti, V., et al.: BoGEMMS: the Bologna Geant4 multi-mission. In: Proceedings SPIE 8453, High Energy, Optical, and Infrared Detectors for Astronomy V, 845335 (25 September 2012). <https://doi.org/10.1117/12.926065> (2012)
15. Bulgarelli, A. et al.: The Agile alert system for gamma-ray transients. *ApJ* **781**, 19 (2014)
16. Bulgarelli, A., Fioretti, V., Parmiggiani, N., et al.: Second AGILE catalogue of gamma-ray sources. *Astron Astrophys* **627**, A13–36 (2019). <https://doi.org/10.1051/0004-6361/201834143>
17. Cattaneo, P.W. et al.: First results about on-ground calibration of the silicon tracker for the AGILE satellite. *NIMA* **630**, 251–257 (2011)
18. CCSDS, Packet Telemetry - CCSDS 102.0-B-5 November 2000, <https://public.ccsds.org/Pubs/102x0b5s.pdf>
19. Chen, A.W., Bulgarelli, A., et al.: AGILE internal report, https://agile.ssdsc.asi.it/public/AGILE_SW_6.0_SourceCode/AGILE_BUILD-SCI-B25_User_Manual_V0.1.pdf (2011)
20. Chen, A.W. et al.: Calibration of AGILE-GRID with in-flight data and Monte Carlo simulations. *A&A* **558**, A37 (2013)

21. Cocco, V. et al.: Simulation of the AGILE gamma-ray imaging detector performance: part II. *NIM A* **486**, 623–638 (2002)
22. Conforti, V. et al.: The ASTRI SST-2M telescope prototype for the Cherenkov Telescope Array: camera DAQ software architecture. In: Proceedings SPIE 9152, Software and Cyberinfrastructure for Astronomy III, 91522D. <https://doi.org/10.1117/12.2054519> (2014)
23. De Angelis, A. et al.: The e-ASTROGAM mission (exploring the extreme Universe with gamma rays in the MeV-GeV range). *Exp. Astron.* **44**, 25–82 (2017)
24. Feroci, M., Costa, E., Soffitta, P., et al.: SuperAGILE: the hard X-ray Imager for the AGILE space mission. *NIM A* **581**, 728 (2007)
25. Fioretti, V., Bulgarelli, A., et al.: Monte Carlo simulations of gamma-ray space telescopes: a BoGEMMS multi-purpose application. In: Proceedings SPIE 9144, Space Telescopes and Instrumentation 2014: Ultraviolet to Gamma Ray, 91443N. <https://doi.org/10.1117/12.2056442> (2014)
26. Gianotti, F., Trifoglio, M., et al.: DISCoS-detector-independent software for on-ground testing and calibration of scientific payloads using the ESA packet telemetry and telecommand standards. *ADASS X. ASP Conf Ser* **238**, 245 (2001)
27. Giuliani, A., Cocco, V., Mereghetti, S., et al.: The AGILE on-board Kalman filter. *NIM A* **568**, 692 (2006)
28. Górski, K.M., Hivon, E., Banday, A.J., et al.: HEALPix: a framework for high-resolution discretization and fast analysis of data distributed on the sphere. *ApJ* **622**, 759 (2005)
29. Labanti, C. et al.: Design and construction of the mini-calorimeter of the AGILE satellite. *NIM A* **598**, 470–479 (2009)
30. Li, T.-P., Ma, Y.-Q.: Analysis methods for results in gamma-ray astronomy. *Apj* **272**, 317 (1983)
31. Longo, F. et al.: Simulation of the AGILE gamma-ray imaging detector performance: part I. *NIM A* **486**, 610–622 (2002)
32. Marisaldi, M. et al.: The mini-calorimeter on-board AGILE: 18 months in orbit. Proceedings IEEE nuclear science symposium conference, 19-25 Oct. 2008, pp 757–764. <https://doi.org/10.1109/NSSMIC.2008.4774597> (2008)
33. Marisaldi, M. et al.: Gamma-ray burst detection with the AGILE mini-calorimeter. *Astron Astrophys* **490**, 1151–1156 (2008)
34. Morselli, A. et al.: GAMMA-LIGHT: high-energy astrophysics above 10 MeV. *Nuclear Physics B Proc. Supp.* **239**(240), 193 (2013)
35. Perotti, F., Fiorini, M., Incorvaia, S., Mattaini, E., Sant Ambrogio, E.: The AGILE anticoincidence detector. *NIM A* **556**, 228 (2006)
36. Pittori, C., Verrecchia, F., Chen, A.W., et al.: First AGILE catalog of high-confidence gamma-ray sources. *A&A* **506**, 1563 (2009)
37. Pittori, C.: AGILE data center and AGILE science highlights. *NuPhS* **239**, 104 (2013)
38. Prest, M., Barbiellini, G., Bordignon, G., et al.: The AGILE silicon tracker: an innovative gamma-ray instrument for space. *NIM A* **501**, 280 (2003)
39. Sabatini, S. et al.: Episodic transient gamma-ray emission from the Microquasar Cygnus X-1. *ApJ* **712**, L10–L15 (2010)
40. Tavani, M., Barbiellini, G., Argan, A., et al.: The AGILE mission. *A&A* **502**, 995–1013 (2009)
41. Tavani, M. et al.: AGILE detection of enhanced gamma-ray emission from the Crab Nebula region, The Astronomers Telegram, 2855 (2010)
42. Trifoglio, M., Gianotti, F., Stephen, J.B., et al.: Ground support equipment for scientific tests and calibration of the AGILE instrument. *Proc SPIE* **4140**, 478–485 (2000)
43. Trifoglio, M., Bulgarelli, A., Gianotti, F., et al.: Architecture and performances of the AGILE telemetry preprocessing system (TMPPS). *Proc SPIE* **7011**, 70113E (2008)
44. Trifoglio, M., et al.: Instrument workstation for the EGSE of the Near Infrared Spectro-Photometer instrument (NISP) of the EUCLID mission. In: Proc. SPIE 9904, Space Telescopes and Instrumentation 2016: Optical, Infrared, and Millimeter Wave, 990460. <https://doi.org/10.1117/12.2234219> (2016)
45. Trifoglio, M., Bulgarelli, A., Gianotti, F., et al.: 7th AGILE Workshop. arXiv:1305.5389 (2013)
46. Vercellone, S. et al.: The Astronomers's Telegram (1160)
47. Zoli, A., Bulgarelli, A., et al.: ADASS XXVI, Trieste (2016)