



Self-Sacrificial Leadership and Employee Behaviours: An Examination of the Role of Organizational Social Capital

Ahmed Mohammed Sayed Mostafa¹ · Paul A. Bottomley²

Received: 21 November 2017 / Accepted: 25 June 2018 / Published online: 28 June 2018
© Springer Nature B.V. 2018

Abstract

Drawing on social exchange theory, this study examines a mechanism, namely organizational social capital (OSC), through which self-sacrificial leadership is related to two types of employee behaviours: organizational citizenship behaviours (OCBs) and counterproductive behaviours (CPBs). The results of two different studies (a field study and an experimental study) in Egypt showed that self-sacrificial leadership is positively related to OSC which, in turn, is positively related to OCBs and negatively related to CPBs. Overall, the findings suggest that self-sacrificial leaders are more likely to achieve desirable employee behaviours through improving the quality of social relationships among employees.

Keywords Self-sacrificial leadership · Organizational social capital · Organizational citizenship behaviours · Counterproductive behaviours

Introduction

Ethical actions are those that transcend self-interest and promote the common good (Carson 2003; Sachdeva et al. 2015). Hence, self-sacrifice is regarded as an essential part of the human moral structure and is believed to be the basis for ethical decisions (Joseph 2015). It is also considered a “powerful signal” for the strength of moral or ethical positions (Sachdeva et al. 2015, p. 2). Self-sacrifice involves forgoing self-interest and taking on personal costs for the benefit of others (De Cremer and van Knippenberg 2004; McKenna and Brown 2011). It is generally viewed as one of the most important behaviours of great leaders (De Cremer and van Knippenberg 2004; van Knippenberg and van Knippenberg 2005). Leader self-sacrifice communicates leader’s commitment to the collective and therefore helps elicit positive leadership perceptions. Research has shown that self-sacrificial leaders are perceived as effective by their followers, and are

attributed charisma and legitimacy (Choi and Mai-Dalton 1999; De Cremer and van Knippenberg 2004; Halverson et al. 2004; Choi and Yoon 2005; van Knippenberg and van Knippenberg 2005). Such leaders have also been found to motivate followers to display desirable behaviours that could enhance organizational effectiveness (De Cremer et al. 2009; Li et al. 2016).

Recently, researchers have begun to explore the mechanisms through which self-sacrificial leadership relates to employee behaviours (Li et al. 2016). This study contributes to this stream of research by examining the mediating role of organizational social capital (OSC), defined as a resource that reflects the character of social relationships within an organization (Leana and Van Buren 1999), on the relationship between self-sacrificial leadership and two types of employee behaviours: organizational citizenship behaviours (OCBs), which are employee activities that are not task related but contribute to the organization, and counterproductive work behaviours (CPBs), which are employee voluntary activities that harm the organization (Kelloway et al. 2002).

Drawing on social exchange theory, it is proposed that self-sacrificial leadership will improve the quality of social relationships among employees within the organization which, in turn, will lead to increased levels of OCBs and reduced levels of CPBs. Social exchange theory is a useful framework for analysing the proposed relationships because

✉ Ahmed Mohammed Sayed Mostafa
Ahmed.mostafa@wbs.ac.uk

Paul A. Bottomley
bottomleypa@cardiff.ac.uk

¹ Warwick Business School, University of Warwick, Coventry, UK

² Cardiff Business School, Cardiff University, Cardiff, UK

of its emphasis on moral obligation, reciprocity, indebtedness and relations between individuals (Chen and Choi 2005; Paillé et al. 2016).

OSC reflects the “goodwill that is engendered by the fabric of social relations” within the organization (Adler and Kwon 2002, p. 17). It has been found to be a significant factor in explaining a number of organizational ethics-related concerns, such as reducing the likelihood of opportunism and increasing cooperative behaviour (Pastoriza et al. 2008). OSC is regarded as a by-product of the ethical work context and is likely to be affected by the ethical and motivational development of organizational members (Pastoriza et al. 2008, 2009). Therefore, bringing ethics into the discussion of OSC formation, through considering the role of self-sacrificial leadership as an antecedent, is considered by some as essential (Pastoriza et al. 2008).

This study focuses on both OCBs and CPBs for a number of reasons. First, both types of behaviour are important because they shape the organizational, psychological and social contexts that act as the impetus for both task processes and activities (Dalal 2005). Second, as mentioned before, OCBs are based on positive behaviours, whereas CPBs are based on negative behaviours. Since both positive and negative social exchange can influence relationships differently, it is important to identify whether self-sacrificial leadership and OSC not only result in positive behaviours but also lead to less involvement in negative work behaviours (Martin et al. 2016). Finally, while the general assumption is that if certain factors could lead to more OCBs then the same factors could also lead to less engagement in CPBs, prior research and meta-analytic findings show that this may not always be the case (Kelloway et al. 2002; Lee and Allen 2002; Dalal 2005; Martin et al. 2016). In fact, findings of previous studies and meta-analyses suggest that the relationship between both types of behaviour is modest (Lee and Allen 2002; Dalal 2005; Den Hartog and Belschak 2012). Therefore, it is essential to assess the likelihood of a differential influence of predictor variables on these two categories of behaviour so as to establish boundary conditions.

This study makes three main contributions to the literature. First, the study contributes to both the field of behavioural ethics and the development of self-sacrificial leadership theory. Self-sacrificial leadership is a relatively new ethical approach to leadership and the development of self-sacrificial leadership theory is believed to be still in “relative infancy” (Matteson and Irving 2006, p. 45). Even though self-sacrificial leadership has been found to be an important predictor of different types of employee work-related behaviours, not much is known about the processes through which this relationship takes place (De Cremer and van Knippenberg 2005; De Cremer et al. 2009; Li et al. 2016). As argued by De Cremer and van Knippenberg (2005, p. 356), the mechanisms linking self-sacrificial leadership

to employee behaviours are “still largely unaddressed in empirical research”. This study seeks to address this issue in the literature by examining the role of OSC as a potential mediator of the relationship between self-sacrificial leadership and both OCBs and CPBs.

Second, this study contributes to the social capital literature by empirically testing whether supervisors’ self-sacrificial leadership contributes to the creation of OSC. Although prior research has shown that OSC is beneficial to organizations (e.g., Leana and Pil 2006; Andrews 2010; Andrews and Mostafa 2017), not much is known about how organizations could develop social capital (Pastoriza et al. 2008; Parzefall and Kuppelwieser 2012; Chuang et al. 2013; Pastoriza and Arino 2013). As stated by Pastoriza and Arino (2013, p. 1), “research has paid little attention to finding empirical evidence concerning how organizations may build social capital”. Specifically, there have been calls for research on the role of leadership in the development of social capital within organizations (Pastoriza et al. 2008; Pastoriza and Arino 2013; Chen et al. 2016). It has been argued that OSC could never emerge if employees are solely self-interested and that to truly create social capital, employees need to develop altruistic motives. Leaders are believed to play a key role in the development of such motives (Pastoriza et al. 2008). This study postulates that, through self-sacrificial behaviours, supervisors could help employees learn to emphasize and establish strong relationships with each other.

Finally, even though social exchange theory is believed to provide an explanation for how OSC could produce its benefits, very limited attention has been given by scholars to testing “whether social capital is reciprocated by employees” (Parzefall and Kuppelwieser 2012, p. 449). This study addresses this limitation in the literature and extends prior OSC research by examining the relationship between social capital and employees OCBs and CPBs. By so doing, the study also contributes to the literature on social exchange theory which has mainly focused on direct dyadic exchange rather than indirect generalized exchange (Coyle-Shapiro and Shore 2007).

The paper proceeds as follows. First, the relationship between self-sacrificial leadership and employee behaviours is discussed. Then, on the basis of social exchange theory, the mediating role of OSC in this relationship is explained. Thereafter, the results of two studies in Egypt, a field study and an experiment, are presented. The final section of the paper discusses the implications of the findings and the limitations of the research.

Self-Sacrificial Leadership and Employee Behaviours

Self-sacrificial leadership represents a relatively new follower-oriented leadership model (Matteson and Irving 2006). It involves “an abandonment or postponement of

personal interests and privileges for the collective welfare” (Choi and Yoon 2005, p. 52). The motivation behind this leadership style is usually grounded in a choice to follow the personal principles of doing what is needed for followers. Thus, sacrificial leaders are “other focused” and are willing to “put everything on the line” for their followers (McKenna and Brown 2011, p. 42).

Self-sacrificial leadership is closely related to other leadership styles, such as servant and transformational leadership. However, it still possesses some unique characteristics. For instance, contrary to transformational leadership which mainly involves motivating followers to commit to the organization’s mission and thus doing what is best for the organization, self-sacrificial leadership mainly involves doing what is best for followers (van Dierendonck 2011; McKenna and Brown 2011). Also, self-sacrificial leadership “goes one step beyond” servant leadership, where it not only involves the consideration of others needs but also involves a desire and readiness to accept the individual costs of this consideration (McKenna and Brown 2011, p. 42).

As mentioned before, the two employee behaviours considered in this study are OCBs and CPBs. OCBs could be defined as discretionary employee behaviours that help improve organizational functioning (Kelloway et al. 2002; Dalal 2005). Such behaviours are *generally* viewed as ethical (Turnipseed, 2002; Bolino and Klotz 2015) and include actions, such as demonstrating concern about the organization’s image, displaying pride when publicly representing the organization and helping others who have been absent (Lee and Allen 2002). On the contrary, CPBs are employee actions that are harmful to the interests of the organization (Kelloway et al. 2002; Dalal 2005). These actions are *usually* regarded as unethical (Samnani et al. 2014; Bolino and Klotz 2015) and may include putting little effort into work or neglecting to follow the supervisor’s instructions or acting rudely towards others (Bennett and Robinson 2000). Both OCBs and CPBs could be divided into behaviours that are directed towards other individuals and behaviours directed towards the organization as a whole (Bennett and Robinson 2000; Lee and Allen 2002; Dalal 2005). The focus in this study will be on both types of OCBs and CPBs.

The relationship between self-sacrificial leadership and employee behaviours could be explained by social exchange theory. Social exchange theory is useful for understanding exchange relationships and ethical conduct at work because of its focus on reciprocity and moral indebtedness (Chen and Choi 2005; Paillé et al. 2016). As argued by Choi and Mai-Dalton (1999), self-sacrificial leadership pressures followers to reciprocate the leader’s self-sacrifice. Self-sacrificial leaders are generally perceived as trustworthy, honest and fair (De Cremer and van Knippenberg 2005). They act in an ethical manner when fulfilling their duties and obligations, and often behave in ways that protect the interest of others.

Such leaders may engage in personally risky behaviours to benefit the collective (De Cremer and van Knippenberg 2004). They are also usually concerned with the needs of their followers and “have their best interests at heart” (De Cremer et al. 2009, p. 888). As a result of all this, followers are more likely to feel a sense of gratitude and indebtedness, and will reciprocate the positive treatment they’ve received by displaying positive behaviours that benefit the organization and refraining from negative behaviours that could harm it (Choi and Mai-Dalton 1998, 1999). Prior research findings provide support for these assumptions and suggest that self-sacrificial leadership is positively related to desirable employee behaviours (De Cremer et al. 2009; Li et al. 2016). However, as mentioned before, not much is known about the mechanisms underlying this relationship (De Cremer and van Knippenberg 2005; De Cremer et al. 2009; Li et al. 2016). This study addresses this issue by suggesting that the self-sacrificial leadership-employee behaviours relationship could be mediated by OSC.

Self-Sacrificial Leadership-Employee Behaviours: OSC as a Mediator

OSC is reflected by the presence of “close interpersonal relationships” among individuals within an organization (Bolino et al. 2002, p. 506). Like both human and physical capital, social capital is viewed as a valuable asset. OSC has three dimensions, namely, structural, relational and cognitive (Nahapiet and Ghosal 1998). The structural dimension refers to the degree to which organizational members are interconnected and share information. The relational aspect refers to the degree to which the relationships and interconnections between organizational members are characterized by trust and emotional intensity. Finally, the cognitive dimension reflects the degree to which individuals within an organization share a common vision and understanding of the organization’s goals (Nahapiet and Ghosal 1998; Leana and Pil 2006). These three dimensions are strongly interrelated and mutually reinforce each other. When people share the same values about their work, they will also be more likely to enjoy high-quality relationships with each other and regularly share information (Leana and Pil 2006; Andrews and Mostafa 2017).

As mentioned before, the development of altruistic, self-transcendent motives in employees is essential for OSC generation and supervisors play a critical role in the development of such motives (Pastoriza and Arino 2013). Supervisors could facilitate employees’ transcendent motives through showing that they are motivated by the same motives and displaying exemplary behaviour (Pastoriza et al. 2008). Supervisors’ behaviours communicate strong messages to employees (Yukl 1989). The more the transcendent motives identified by employees in their supervisors behaviours, the

greater will be the likelihood that employees identify with their supervisors, and consequently the organization, and include transcendent motives in their decisions (Pastoriza et al. 2008). Indeed, research has shown that when employees perceive that their supervisors appeal to their altruistic motives, they become strongly driven by transcendent motives and strongly identify with the organization (Wayne and Green 1993; Walumbwa et al. 2011).

Self-sacrificial behaviours enhance altruism and bring about a “consistent concern” for others (Singh and Krishnan 2008, p. 265). As argued by Matteson and Irving (2006, p. 45), the main focus of self-sacrificial leadership is “ethical self-transcendence”. Self-sacrificial leaders are others-centred and oriented towards empathy and altruism (Matteson and Irving 2006; McKenna and Brown 2011). These leaders play a significant role in influencing followers’ value internalization and in shaping their perceptions of the importance of the collective’s needs (Li et al. 2016). Through self-sacrificial behaviours, such leaders also make the organization’s mission more salient to followers and activate values and goals that include giving up self-interest for the good of the collective (De Cremer and van Knippenberg 2005; De Cremer et al. 2009).

Self-sacrificial leaders also positively contribute to the fulfilment of employees’ basic psychological needs including the need for relatedness (Li et al. 2016). The dutiful nature of such leaders and their efforts to understand and satisfy employees’ needs usually lead followers to perceive that the collective views them as important, and therefore enhances their feeling of belonging and inclusion (De Cremer et al. 2006; Li et al. 2016).

Furthermore, leaders self-sacrifice convincingly suggests that the collective is worthy of one’s devoted attention and effort, which helps increase the value of collective identity for followers. Through enhancing collective identification, self-sacrificial leaders shift followers’ emphasis from exclusively the pursuit of only their personal interests to the pursuit of collective interests (De Cremer and van Knippenberg 2004). This stimulates cooperation and motivates followers to go beyond their self-interest and care about the collective welfare (De Cremer and van Knippenberg 2004, 2005). All this is more likely to lead to an environment in which employees develop good social relationships, establish a shared vision, and work together in achieving common goals. Accordingly, the following hypothesis is proposed:

Hypothesis 1 Self-sacrificial leadership will be positively related to OSC.

OSC can also induce desirable employee behaviours. According to Parzefall and Kuppelwieser (2012, p. 449), social exchange theory and the norm of reciprocity “provide the explanatory mechanisms” for how OSC generates

its benefits. OSC is believed to contribute to an employee’s sense of indebtedness and perceived obligation to reciprocate the collaborative work atmosphere. This means that the cycle of reciprocity in taking and giving extends beyond dyadic relationships and interactions (Leana and Van Buren 1999; Parzefall and Kuppelwieser 2012). This is in line with social exchange theory which suggests that an individual does not solely reciprocate directly the source of the received benefits, but also reciprocates others involved in the processes of exchange (referred to as generalized social exchange; Ekeh 1974; Lazega and Pattison 1999; Lawler 2001; Das and Teng 2002).

Through displaying citizenship behaviours and refraining from counterproductive behaviours, an employee reciprocates perceptions of working in an organization in which individuals trust each other, share similar goals and values, and have access to valued information, despite the fact that the main source of these benefits is employee networking and collaboration, and indirectly only the organization (Parzefall and Kuppelwieser 2012). An employee may also recognize the efforts made by the organization to develop social capital; for instance, when leaders, who are organizational representatives, create an environment which helps improve the quality of social relationships within the organization, and consequently reciprocate these efforts. Accordingly, the following hypotheses are proposed:

Hypothesis 2 OSC will be (a) positively related to employees OCBs and (b) negatively related to employees CPBs.

Hypothesis 3 OSC will mediate the relationship between self-sacrificial leadership and employees (a) OCBs and (b) CPBs.

Empirical Studies

To test the proposed hypotheses, two studies were conducted in Egypt. The first was a field study within an organizational setting (Study 1) and the second was an experimental study (Study 2). Field studies provide external validity, whereas experimental studies provide internal validity and help draw conclusions regarding casual relationships (Dipboye 1990; De Cremer et al. 2009).

Study 1 examined the mediating role of OSC on the relationship between self-sacrificial leadership and both OCBs and CPBs directed towards the organization. On the other hand, Study 2 examined the mediating role of OSC on the link between self-sacrificial leadership and behaviours directed towards both other individuals and the organization. Study 2 also built on Study 1 by controlling for relevant self-sacrificial leadership characteristics. This constructive

replication helps add confidence regarding the validity of the findings (Lykken 1968; Schmidt 2009).

Study 1

This field study examines the mediating role of OSC on the relationship between self-sacrificial leadership and employee behaviours in an organizational context.

Sample and Procedure

The data for this study were collected using a pen and paper questionnaire from a sample of nurses and their immediate supervisors in a large public hospital in Egypt. Nurses filled in questionnaires on their supervisors' self-sacrifice and OSC, while supervisors assessed nurses OCBs and CPBs. This procedure was followed so as to minimize the risk of common method bias (Podsakoff et al. 2003, 2012). Also, to lower the risk of social desirability bias, respondents were individually contacted, rather than through the hospital, and the questionnaires were handed to them on a face-to-face basis at work. They were also promised anonymity and confidentiality (Miao et al. 2013; Bottomley et al. 2016).

Out of the 350 distributed questionnaires, 204 were returned, resulting in a 58.3% response rate. Ninety-three percent of the nurses in the sample were female. More than half of the participants (55.4%) were aged between 20 and 30, 27% were aged between 31 and 40, and the remainder were over 40 years old. As for length of service, 39% had worked for more than 15 years in the hospital, 19% had worked for between 10 and 15 years, and the remainder had been working in the hospital for less than 10 years.

Measures

The questionnaires were translated from English into Arabic using Brislin's (1970) back-translation procedure. The translated Arabic questionnaires were then pre-tested by a number of nurses and their supervisors from the participating hospital. All items were rated on 7-point Likert scales in which 1 = 'Strongly disagree' and 7 = 'Strongly agree'.

Self-Sacrificial Leadership A 5-item scale developed by De Cremer and van Knippenberg (2004) was used to measure self-sacrificial leadership. Sample items include "I can always count on my supervisor to help me in times of trouble, even if it is at costs to him/her" and "My supervisor is always among the first to sacrifice free time". Cronbach's alpha (α) for this scale was 0.874.

Organizational Social Capital Social capital was measured using 12 items developed by Leana and Pil (2006). Each of the three dimensions (i.e., structural, relational and cog-

nitive) was represented by four items. Sample items are "Nurses discuss personal issues if they affect job performance" (structural dimension), "Overall, nurses at this hospital are trustworthy" (relational dimension) and "Nurses enthusiastically pursue collective goals and mission" (cognitive dimension). Cronbach's alpha for information sharing was 0.714, for trust was 0.813 and for shared vision was 0.830. In line with previous research (e.g., Leana and Pil 2006; Parzefall and Kuppelwieser 2012; Chuang et al. 2013; Chen et al. 2016), OSC was treated in the analysis as a higher order, overall construct.

Organizational Citizenship Behaviour Four items developed by Lee and Allen (2002) were used to measure OCB. As mentioned before, these items were rated by supervisors. A sample item is "This employee takes action to protect the hospital from potential problems". Cronbach's alpha was 0.882.

Counterproductive Behaviour CPB was also rated by supervisors using 4 items developed by Bennett and Robinson (2000). A sample item is "This employee comes in late to work without permission". Cronbach's alpha for this scale was 0.853.

Controls At first, the effects of nurses gender, age and tenure on both OSC and employee behaviours were controlled for (Lee and Allen 2002; Parzefall and Kuppelwieser 2012; Pastoriza and Arino 2013), and the results were almost the same with and without their inclusion. Therefore, in the interest of parsimony, and in line with Williams et al. (2009) recommendations, the results are reported without controls.

Analysis

Anderson and Gerbing's (1988) two-step approach to structural equation modelling (SEM) was followed. The first step involved conducting confirmatory factor analyses (CFA) for validating the measurement model, whereas the second involved testing the structural model.

Measurement Validation

The measurement model was evaluated in two stages. The first stage involved conducting a CFA for a second-order measurement model of OSC, in which the three dimensions of OSC were treated as first-order factors and each dimension's four items were the observed indicators. The second stage involved conducting a CFA for the overall measurement model where the four latent constructs (self-sacrificial leadership, the second-order OSC construct, OCBs and CPBs) were correlated with each other. Three indices were used to assess model fit: the comparative fit index (CFI), the

root mean square error of approximation (RMSEA), and the standardized root mean square residual (SRMR). CFI values of 0.90 or more, RMSEA values of 0.08 or less and SRMR values of 0.10 or less suggest good fit (Williams et al. 2009).

The second-order measurement model of OSC exhibited good fit (χ^2 (df = 51) = 130.965, $p < 0.01$; CFI = 0.919, RMSEA = 0.088, and SRMR = 0.052). The standardized second-order factor loadings were 0.694 for the structural dimension (information sharing), 0.917 for the relational dimension (trust), and 0.889 for the cognitive dimension (shared vision), and all were significant at the $p < 0.01$ level. The overall measurement model also exhibited good fit (χ^2 (df = 266) = 475.459, $p < 0.01$; CFI = 0.914, RMSEA = 0.062, and SRMR = 0.055). All constructs possessed high internal consistency whereby all composite reliability scores were greater than 0.80 and average variance extracted scores were greater than 0.50. All constructs also achieved discriminant validity whereby, as shown in Table 1, the square root of the average variance extracted for each construct exceeded the corresponding interconstruct correlations (Fornell and Larcker 1981).

Finally, since both the independent and mediator variables were measured by the same respondents, the presence

of common method bias was also tested. Method bias was tested using the latent method factor approach, which involved estimating a measurement model in which the items of self-sacrificial leadership and OSC were allowed to load on their theoretical constructs and a common factor. The fit of this model was good (χ^2 (df = 98) = 196.310, $p < 0.01$; CFI = 0.936, RMSEA = 0.070, and SRMR = 0.054), but more importantly, the variance extracted by the common factor was 0.034, which is much below the 0.50 threshold suggested by Fornell and Larcker (1981) as indicative of a substantive factor. Thus, common method bias does not appear unduly problematic in this study.

Structural Model Results

The fit of the proposed model was good (χ^2 (df = 267) = 480.698, $p < 0.01$; CFI = 0.912, RMSEA = 0.063, and SRMR = 0.059). In the model, self-sacrificial leadership and OSC explained together almost 12% of the variance in OCBs ($R^2 = 0.117$) and 3.4% of the variance in CPBs. Furthermore, self-sacrificial leadership accounted for 10% of the variance in OSC.

As regards to the individual paths, as shown in Fig. 1, self-sacrificial leadership had a significant positive association with OSC ($\beta = 0.317$, $p < 0.01$), suggesting that self-sacrificial leadership stimulates high-quality social relationships within the organization. Therefore, Hypothesis 1 was supported. In turn, OSC had a significant positive relationship with OCBs ($\beta = 0.295$, $p < 0.01$) and negative relationship with CPBs ($\beta = -0.187$, $p < 0.05$). Thus, Hypothesis 2 was also supported. Together, these findings provide prima facie evidence that OSC mediated the relationship between self-sacrificial leadership and employee behaviours.

To examine the significance of the indirect relationship between self-sacrificial leadership and employee behaviours, Preacher and Hayes (2004) bootstrapped approach was used. The test results indicated that both the indirect pathway from self-sacrificial leadership through OSC to OCBs as well as the indirect path of self-sacrificial leadership via OSC to CPBs were significantly different from zero ($\beta = 0.09$, $z = 2.177$, $p < 0.01$ and $\beta = -0.06$, $z = -1.78$, $p < 0.10$,

Table 1 Inter-correlations and reliability estimates

Construct	1	2	3	4
1. Self-sacrificial Leadership	0.76 (0.88)*			
2. OSC	0.318***	0.84 (0.88)		
3. OCBs	0.196**	0.321***	0.81 (0.88)	
4. CPBs	-0.044	-0.172**	-0.224***	0.79 (0.86)
Mean	5.067	5.710	5.715	1.862
SD	1.545	0.836	1.032	1.120

OSC organizational social capital, OCBs organizational citizenship behaviours, CPBs counterproductive work behaviours

*Sub-diagonal entries are the latent construct inter-correlations. The diagonal shows the square root of the AVE with composite reliability in parentheses

*** $p < 0.01$, ** $p < 0.05$

Fig. 1 Structural model results (standardized coefficients). *** $p < 0.01$, ** $p < 0.05$

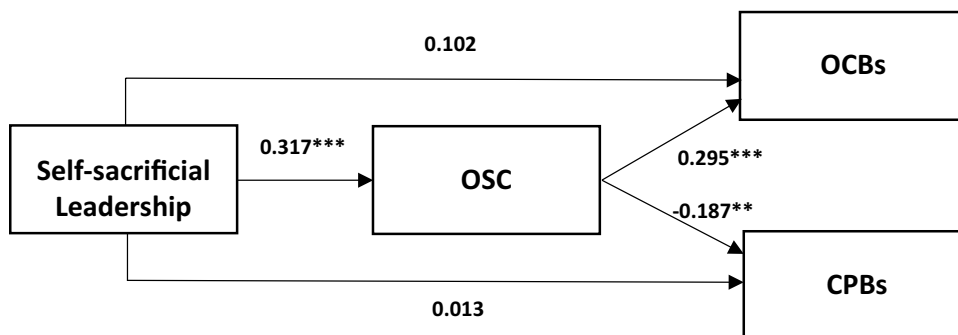

respectively). Thus, hypothesis 3 was also supported. The direct path from self-sacrificial leadership to both OCBs and CPBs was non-significant, which indicates that OSC acts as a full rather than a partial mediator of the relationship between self-sacrificial leadership and employee behaviours validating our proposed conceptual model.

To summarize, using Zhao et al.'s (2010) influential typology of mediation, the case of CPBs is an example of "indirect-only mediation", as the path between self-sacrificial leadership and the outcome was not statistically significant (see correlation matrix, Table 1), while in the case of OCBs, this is an example of "complementary mediation" as the indirect effect and the direct path between self-sacrificial leadership and the outcome were both significant and had the same sign.

Study 2

To provide stronger evidence for the mediating role of OSC on the link between self-sacrificial leadership and employee behaviours and to bolster assurances as regards the causality of Study 1's findings, Spencer et al. (2005) experimental causal chain design approach was used in Study 2. Spencer et al. (2005) contend that measurement-of-mediation designs (like Study 1), although the default standard, should only be used when the proposed underlying process is easy to measure but difficult to manipulate. When the mediator is easy to manipulate, experimental causal chain designs offer a more powerful methodological approach (see Geuens and de Pelsmacker 2017; Pirlott and MacKinnon 2016 for reviews and applications). Here, via a series of experiments, each "link" (mediating variable) in the casual chain is first measured in one experiment (dependent variable) and then manipulated in another experiment (predictor variable) moving along the proposed casual chain. In our context, this approach involves conducting two experiments: in Study 2A, we examine the effect of self-sacrificial leadership on OSC, while in Study 2B we examine the effect of OSC on employee behaviours. Study 2 also extends Study 1 by controlling for characteristics relevant to self-sacrificial leadership such as ethical consideration, inspirational motivation and self-confidence (De Cremer and van Knippenberg 2004), in addition to testing the effects of social capital on citizenship and deviant behaviours directed towards both other individuals (i.e. co-workers) and the organization.

Study 2A: Self-Sacrificial Leadership and Social Capital

Procedure

Sixty-seven physicians from a public sector hospital in Egypt participated in this study. Participants were handed

a pen and paper study and randomly assigned to one of the two conditions: the self-sacrificing leader condition or non-self-sacrificing leader condition. It was emphasized that participation in this academic study was voluntary, responses would be anonymous, and results aggregated. Participants in the self-sacrificing leader condition were asked to imagine that they had experienced first-hand the following situation (scenario):

Imagine that you've moved to a new hospital and that you've been working in a new department for several weeks. During these weeks you've formed a clear impression of your supervisor in the department.

He will do all that he can for the department's welfare. He spends a lot of time at work and may do extra shifts to cover for others, which means that sometimes he may not be able to spend much time with his family and meet their needs and requirements. When others in the department face financial problems, he has been known to lend them his own money. He has also been involved in several disputes with the hospital's top management for the sake of the department. Because of his helping nature, he frequently misses out opportunities to promote his own self-interest.

In the non-self-sacrificing leader condition, the second paragraph was replaced with:

He does not care much for the department's welfare. He spends very little time at work and avoids doing extra shifts, which means that he spends much time with his family. When others in the department face financial problems, he won't lend them his own money. He also tries to avoid getting involved in disputes with the hospital's top management even if this would be for the sake of the department. Because he cares about his own self-interest, he will always try to make use of any opportunities that would benefit him.

The dependent measures and controls were then solicited. Responses to all questions were on 7-point Likert-type scales (1 = not at all, 7 = very much so). To assess the effectiveness of the self-sacrificing leader behaviour manipulation, participants were asked two questions taken from De Cremer et al. (2006): "To what extent does this leader show self-sacrificing behaviour?" and "To what extent does this leader show self-benefiting behaviour?" (reverse coded). Both items were averaged to form a self-sacrifice index [Cronbach's alpha (α) = 0.90]. To control for relevant self-sacrificial leadership characteristics, three items based on Bass and Avolio (1995) were also included. These were: "To what extent does this leader consider the moral and ethical consequences of decisions?" (consideration of ethics), "To what extent does this leader have confidence in himself?" (self-confidence), and "To what extent

does this leader emphasize the importance of having a collective sense of mission?" (inspirational motivation). Social capital, the dependent variable, was measured using a subset of 6 (from 18) items developed by Leana and Pil (2006). Following the stem "To what extent would working with this supervisor help you and your colleagues..." items comprised: (i) "engage in open and honest communication with one another?", (ii) "willingly share information with one another" (information sharing), (iii) "view others as trustworthy", (iv) "have confidence in one another?" (trust), (v) "enthusiastically pursue collective goals and mission?" and (vi) "have a commonality of purpose" (shared vision). These six items were averaged to form an OSC index ($\alpha=0.97$).

Results

Manipulation Check A one-way ANOVA on the self-sacrifice index confirmed that participants in the self-sacrificing condition perceived their leader as more sacrificing and less self-benefitting ($M=5.61$, $SD=1.07$) than those in the non-self-sacrificing condition ($M=2.85$, $SD=1.50$, $F(1, 65)=74.23$, $p<0.001$).

The Effect of Self-Sacrificial Leadership on OSC To test the effect of self-sacrificing leadership on OSC, hierarchical regression analysis was used. Ethical consideration, inspirational motivation and leader self-confidence were entered in the first step, whereas self-sacrificial leadership was entered in the second step. This allows us to assess the incremental variance explained by self-sacrificing leadership *beyond* that already captured by the related leadership characteristics that conceptually may overlap with it. As such, it offers a more conservative test of our proposed theoretical model, the alternative being to enter all the predictors simultaneously, thereby putting each predictor on an *equal* statistical footing.

The regression results revealed that, in the first step, the effects of ethical consideration and self-confidence were not significant, whereas inspirational motivation was significant ($\beta=0.450$, $p<0.01$). More importantly, self-sacrificial leadership (dummy coded = 1, non-self-sacrificial condition = 0) was significant in the second step ($\beta=0.861$, $p<0.01$), and incrementally explained 0.331% additional variance (ΔR^2 was significant, $\Delta F(1, 65)=45.354$, $p<0.001$). These results confirm that self-sacrificial leadership can lead to increased organizational social capital, consistent with the first link of the mediated process.

Study 2B: Social Capital and Employee Behaviours

Procedure

Sixty-eight different physicians from the same hospital as Study 2A took part in this study. The procedure was

similar to before, except on this occasion participants were randomly assigned to either the high OSC or low OSC condition. These scenarios were designed using the 18-item pool developed by Leana and Pil (2006) to measure OSC, the dependent variable in Study 2A. Specifically, in the high OSC condition, the scenario read as follows (text in italics and parentheses refers to the low OSC condition):

Imagine that you've moved to a new hospital and that you've been working in a new department for several weeks. During these weeks you've formed a clear impression of the department and your colleagues. You feel that you (*do not*) fit very well into the department and that you (*don't*) have very good relationships with your colleagues. You (*do not*) engage in open and honest communication with one another and willingly (*rarely*) share information on a regular basis. You also feel that your colleagues are (*not*) trustworthy and you (*don't*) have confidence in them. All of you think the same (*differently*) about work and (*don't*) share the same vision for the department.

The dependent measures and covariates were then solicited using 7-point Likert-type scales (1 = not at all, 7 = very much so). To assess the effectiveness of the OSC manipulation, participants were presented with six different statements taken from Leana and Pil (2006) "item-pool". Following the stem, "To what extent do you think that you and your colleagues will..." the five statements read "accept constructive criticisms without making it personal?", "discuss personal issues if they affect job performance?" (information sharing), "be considerate of one another's feelings?" (trust), "be committed to the goals of the department?" and "view yourselves as partners in charting the department's direction?" (shared vision). The sixth item read, "To what extent do you think that you can rely on the colleagues you work with in this department?" (trust). Again, the six items were averaged to form an OSC index ($\alpha=0.87$).

Four items developed by Lee and Allen (2002) were used to measure OCBs: "Willingly give your time to help others who have work-related problems" and "Help others who have been absent" measured behaviours directed towards individuals ($\alpha=0.93$); while "Defend the department when others criticize it" and "Take action to protect the department from potential problems" measured behaviours directed towards the organization ($\alpha=0.95$). Lastly, four items developed by Bennett and Robinson (2000) were used to measure CPBs: "Make fun of others at work" and "Act rudely towards others at work" measured behaviours directed towards individuals ($\alpha=0.92$); while "Come in late to work without permission" and "Put little effort into work" measured behaviours directed towards the organization ($\alpha=0.92$).

Results

Manipulation Check A one-way ANOVA of the organizational social capital index confirmed that participants in the high OSC condition ($M=5.18$, $SD=0.64$) were more likely to share similar values, more frequently exchange information, and trust one another, than those in the low OSC condition ($M=3.90$, $SD=1.11$, $F(1, 66)=34.08$, $p<0.001$), as anticipated.

The Effect of OSC on Employee Behaviours To test the effect of OSC on both OCBs and CPBs, four hierarchical regression models were conducted. Gender and age were entered in the first step, whereas OSC was entered in the second. (As the scenarios provided no information about the departmental leader's style of leadership, unlike Study 2A, those variables were not recorded and controlled for here.) In step 1, the effect of gender and age was non-significant in all four models. But more importantly, the effect of OSC (dummy coded, 1=high, 0=low) was significant and positive on OCBs towards the organization ($\beta=0.812$, $p<0.01$) and individuals ($\beta=0.828$, $p<0.01$; $\Delta R^2=0.659$, $\Delta F(1, 66)=127.286$, $p<0.01$ for organization directed OCBs and $\Delta R^2=0.685$, $\Delta F(1, 66)=143.737$, $p<0.01$ for individual directed OCBs). Also, the effect of OSC was significant and negative on CPBs towards the organization ($\beta=-0.835$, $p<0.01$) and individuals ($\beta=-0.804$, $p<0.001$; $\Delta R^2=0.698$, $\Delta F(1, 66)=152.582$, $p<0.001$ for organization directed CPBs and $\Delta R^2=0.646$, $\Delta F(1, 66)=120.557$, $p<0.01$ for individual directed CPBs). These results confirm that OSC leads to increased OCBs and reduced CPBs.

Together, the findings of both study 2A and study 2B provide stronger evidence for the mediating role of OSC on the link between self-sacrificial leadership and employee behaviours. In addition, we have replicated the conceptual model across groups of nurses and physicians, and generalized the results to both individual and organizational level outcomes.

Discussion

Researchers have recently begun to explore the mechanisms through which self-sacrificial leadership relates to employee behaviours. This paper has contributed to this stream of research by examining the mediating role of OSC on the relationship between self-sacrificial leadership and both OCBs and CPBs. In line with the proposed hypotheses, the findings of both the field and the experimental studies revealed that self-sacrificial leadership induces higher-quality social relationships among employees within the organization which, in turn, leads to increased levels of OCBs and reduced levels of CPBs.

The finding that self-sacrificial leadership is positively related to OSC is in line with the assumption that self-sacrificial leaders help facilitate employees' transcendent motives through showing that they are motivated by the same concerns and displaying exemplary role-modelling behaviours (Pastoriza et al. 2008). It also provides support for the argument that self-sacrificial leaders shape employees' perceptions of the importance of the collective's needs and enhance shared trust and collective goals and actions (De Cremer and van Knippenberg 2004; Li et al. 2016). However, it is worth noting that, in the field study, the effect size of self-sacrificial leadership on OSC was modest ($R^2=0.10$). This suggests that even though self-sacrificial leadership is a notable predictor of OSC, it is certainly not the only predictor. Prior research has shown that, besides leadership, other factors such as HRM practices, reduced work load and stable work environments could help nurture social capital (Parzefall and Kuppelwieser 2012; Chuang et al. 2013; Pastoriza and Arino 2013). Accordingly, it is anticipated that role of self-sacrificial leadership in conjunction with these factors will together be more insightful.

The study findings also demonstrate that OSC is positively related to OCBs and negatively related to CPBs. This is in line with the notion of generalized social exchange, which suggests that individuals do not only reciprocate directly the source of the received benefits, but also reciprocate others involved in exchange processes (Ekeh 1974; Lazega and Pattison 1999; Lawler 2001; Das and Teng 2002). Findings also show that OSC plays a central role in the relationship between self-sacrificial leadership and employee behaviours. OSC mediated the relationship between self-sacrificial leadership and both OCBs and CPBs, the former in a complementary manner, the latter only indirectly so using Zhao et al.'s, (2010) influential typology of mediation. Thus, self-sacrificial leadership is related to employee behaviours because of its association with social relationships among employees.

Finally, it is noteworthy that, in the field study, self-sacrificial leadership together with OSC only explained 12 percent of the variance in OCBs and 3.4 per cent of the variance in CPBs. A number of individual and organizational factors, such as affect, conscientiousness, motivation and organizational justice, have been identified in prior research as predictors of both OCBs and CPBs (Lee and Allen 2002; Dalal 2005; Den Hartog and Belschak 2012). However, there clearly is still a need for more research on the antecedents of both types of behaviour, especially CPBs (Dalal 2005).

Practical Implications

The study findings suggest that self-sacrificial leadership leads to desirable employee behaviours through enhancing the quality of social relationships among employees.

Therefore, organizations need to develop procedures for the selection and promotion of self-sacrificial managers (De Cremer et al. 2009). Organizations may also rely on leadership training and development programs that are based on self-sacrifice, stressing the importance of role modelling, and developing an appreciation of workers' goals and aspirations, rather than simply looking after themselves and focusing on the next career move. Such programs could help managers understand the influence of self-sacrificial behaviours on employees and the organization (Li et al. 2016).

However, it is important to note that frequent and excessive display of self-sacrificial leadership could be harmful to both the manager themselves and the organization. For example, if a leader frequently takes on big proportions of the work load to enable workers more time off, then poor performance may be encouraged and underperforming employees will be masked. Similarly, an increase in self-sacrifice could sometimes cost leaders their jobs, pride and personal comfort (van Knippenberg, and van Knippenberg 2005; Arnold and Loughlin 2010; McKenna and Brown 2011). Therefore, achieving a balance between self-sacrifice and self-interest is essential for effective leadership (Avolio and Locke 2002).

The findings also highlight the importance of promoting the exchange relationships between employees. The promotion of such relationships will result in tangible benefits for the organization, such as reduced turnover and absenteeism rates, and increased levels of innovation, as well as intangible benefits, such as improved employee attitudes and behaviours (Parzefall and Kuppelwieser 2012). Besides leadership, investments in HRM practices, organizational transparency and reasonable workloads could be useful in this regard (Parzefall and Kuppelwieser 2012; Chuang et al. 2013).

Limitations and Directions for Future Research

First, because of the cross-sectional design of Study 1, strong causal inferences could not be made. For example, it could be possible that OCBs lead to the development of social capital within organizations or that social capital leads to employee perceptions of self-sacrificial leadership. The experimental evidence provided by Study 2 helps, to some extent, alleviate such causality concerns. Furthermore, the causal directions proposed in this study are in line with previous studies (e.g. De Cremer et al. 2009; Parzefall and Kuppelwieser 2012; Pastoriza and Arino 2013; Chen et al. 2016; Li et al. 2016). However, future field studies with longitudinal designs are needed to allow for more definitive conclusions about reverse causality. Second, since both Study 1 and Study 2 were conducted in public sector hospitals in Egypt,

the extent to which the findings could be generalized remains unknown. It would be interesting to test whether the study findings could be extrapolated to other settings and contexts, beyond nurses and physicians. Third, as mentioned before, self-sacrificial leadership is closely related to other leadership styles, such as servant and transformational leadership. In Study 2, characteristics that are of relevance to self-sacrificial leadership such as ethical consideration, inspirational motivation and self-confidence have been controlled for (De Cremer and van Knippenberg 2004). However, the possible influence of relevant leadership styles and characteristics was not controlled for in Study 1. Future field studies could include these styles and characteristics as controls so as to identify the additional variance that self-sacrificial leadership could explain on employee behaviours. Finally, the focus in this study was on the positive outcomes of self-sacrificial leadership. As mentioned before, self-sacrificing behaviours are not always beneficial and could sometimes be detrimental to leaders themselves (van Knippenberg, and van Knippenberg 2005; Arnold and Loughlin 2010; McKenna and Brown 2011). Future research may, therefore, wish to consider the disadvantages and costs of self-sacrificial leadership from a multiple stakeholder perspective.

Despite these limitations, the study has shown that OSC is an important mechanism through which self-sacrificial leadership is associated with employee behaviours in organizations.

Compliance with Ethical Standards

Conflict of Interest The authors declare that they have no conflict of interest.

Ethical Approval All procedures performed in the study involving human participants were in accordance with the ethical standards of the institutional and/or national research committee and with the 1964 Helsinki declaration and its later amendments or comparable ethical standards. This article does not contain any studies with animals performed by the authors.

Informed Consent Informed consent was obtained from all individual participants included in the study.

References

- Adler, P. S., & Kwon, S. (2002). Social capital: Prospects for a new concept. *Academy of Management Review*, 27(1), 17–40.
- Anderson, J. C., & Gerbing, D. W. (1988). Structural equation modeling in practice: A review and recommended two-step approach. *Psychological Bulletin*, 103(3), 411–423.
- Andrews, R. (2010). Organizational social capital, structure and performance. *Human Relations*, 63(5), 583–608.
- Andrews, R., & Mostafa, A. M. S. (2017). Organizational goal ambiguity and senior public managers' engagement: Does organizational social capital make a difference? *International Review of Administrative Sciences*. <https://doi.org/10.1177/0020852317701824>.

- Arnold, K. A., & Loughlin, C. (2010). Individually considerate transformational leadership behaviour and self-sacrifice. *Leadership & Organization Development Journal*, 31(8), 670–686.
- Avolio, B. J., & Locke, E. E. (2002). Contrasting different philosophies of leader motivation: Altruism versus Egoism. *The Leadership Quarterly*, 13(2), 169–191.
- Bass, B. M., & Avolio, B. J. (1995). *Multifactor leadership questionnaire report*. Palo Alto, CA: Mind Garden.
- Bennett, R. J., & Robinson, S. J. (2000). Development of a measure of workplace deviance. *Journal of Applied Psychology*, 85(3), 349–360.
- Bolino, M. C., & Klotz, A. C. (2015). The paradox of the unethical organizational citizen: The link between organizational citizenship behaviour and unethical behaviour at work. *Current Opinion in Psychology*, 6, 45–49.
- Bolino, M. C., Turnley, W. H., & Bloodgood, J. M. (2002). Citizenship behavior and the creation of social capital in organizations. *The Academy of Management Review*, 27(4), 505–522.
- Bottomley, P., Mostafa, A. M. S., Gould-Williams, J. S., & Leon-Cazares, F. (2016). The impact of transformational leadership on organizational citizenship behaviours: The contingent role of public service motivation. *British Journal of Management*, 27, 390–405.
- Brislin, R. W. (1970). Back-translation for cross-cultural research. *Journal of Cross-Cultural Psychology*, 1, 185–216.
- Carson, T. L. (2003). Self-Interest and business ethics: Some lessons of the recent corporate scandals. *Journal of Business Ethics*, 43, 389–394.
- Chen, L., Zheng, W., Yang, B., & Bai, S. (2016). Transformational leadership, social capital and organizational innovation. *Leadership and Organization Development Journal*, 37(7), 843–859.
- Chen, S., & Choi, C. J. (2005). A social exchange perspective on business ethics: An application to knowledge. *Journal of Business Ethics*, 62, 1–11.
- Choi, Y., & Mai-Dalton, R. R. (1998). On the leadership function of self-sacrifice. *The Leadership Quarterly*, 9, 475–501.
- Choi, Y., & Mai-Dalton, R. R. (1999). The model of followers' responses to self-sacrificial leadership: An empirical test. *The Leadership Quarterly*, 10, 397–421.
- Choi, Y., & Yoon, J. (2005). Effects of leaders' self-sacrificial behaviour and competency on followers' attribution of charismatic leadership among Americans and Koreans. *Current Research in Social Psychology*, 11, 51–69.
- Chuang, C.-H., Chen, S.-J., & Chuang, C.-W. (2013). Human resource management practices and organizational social capital: The role of industrial characteristics. *Journal of Business Research*, 66, 678–687.
- Coyle-Shapiro, J., & Shore, L. (2007). The employee organization relationship: Where do we go from here? *Human Resource Management Review*, 17(2), 166–179.
- Dalal, R. S. (2005). A meta-analysis of the relationship between organizational citizenship behaviour and counterproductive work behaviour. *Journal of Applied Psychology*, 90(6), 1241–1255.
- Das, T. K., & Teng, B.-S. (2002). Alliance constellations: A social exchange perspective. *Academy of Management Review*, 27(3), 445–456.
- De Cremer, D., Mayer, D. M., van Dijke, M., Schouten, B. C., & Bardes, M. (2009). When does self-sacrificial leadership motivate prosocial behavior? It depends on followers' prevention focus. *Journal of Applied Psychology*, 94, 887–899.
- De Cremer, D., & van Knippenberg, D. (2004). Leader self-sacrifice and leadership effectiveness: The moderating role of leader self-confidence. *Organizational Behaviour and Human Decision Processes*, 95, 140–155.
- De Cremer, D., & van Knippenberg, D. (2005). Cooperation as a function of leader self-sacrifice, trust, and identification. *Leadership & Organization Development Journal*, 26, 355–369.
- De Cremer, D., van Knippenberg, D., van Dijke, M. H., & Bos, A. E. R. (2006). Self-sacrificial leadership and follower self-esteem: When collective identification matters. *Group Dynamics: Theory, Research, and Practice*, 10, 233–245.
- Den Hartog, D. N., & Belschak, F. D. (2012). Work engagement and machiavellianism in the ethical leadership process. *Journal of Business Ethics*, 107, 35–47.
- Dipboye, R. L. (1990). Laboratory vs. field research in industrial and organizational psychology. *International Review of Industrial and Organizational Psychology*, 5, 1–34.
- Ekeh, P. P. (1974). *Social exchange theory: The two traditions*. Cambridge: Harvard University Press.
- Fornell, C., & Larcker, D. F. (1981). Evaluating structural equation models with unobservable variables and measurement error. *Journal of Marketing Research*, 18(1), 39–50.
- Geuens, M., & de Pelsmacker, P. (2017). Planning and conducting experimental advertising research and questionnaire design. *Journal of Advertising*, 46(1), 83–100.
- Halverson, S. K., Holladay, C. L., Kazama, S. M., & Quinones, M. A. (2004). Self-sacrificial behavior in crisis situations: The competing roles of behavioural and situational factors. *Leadership Quarterly*, 15, 263–275.
- Joseph, J. (2015). Self-interest and altruism: Pluralism as a basis for leadership in business. *Business and Management Studies*, 1(2), 106–114.
- Kelloway, E. K., Loughlin, C., Barling, J., & Nault, A. (2002). Self-reported counterproductive behaviours and organizational citizenship behaviours: Separate but related constructs. *International Journal of Selection and Assessment*, 10(1–2), 143–151.
- Klotz, A. C., & Bolino, M. C. (2013). Citizenship and counterproductive work behaviour: A moral licensing view. *Academy of Management Review*, 38(2), 292–306.
- Lawler, E. J. (2001). An affect theory of social exchange. *American Journal of Sociology*, 107(2), 321–352.
- Lazega, E., & Pattison, P. E. (1999). Multiplexity, generalized exchange and cooperation in organizations: A case study. *Social Networks*, 21, 67–90.
- Leana, C. R., & Pil, F. K. (2006). Social capital and organizational performance: Evidence from urban public schools. *Organization Science*, 17(3), 353–366.
- Leana, C. R., & Van Buren, H. (1999). Organizational social capital and employment practices. *Academy of Management Review*, 24(3), 538–555.
- Lee, K., & Allen, N. J. (2002). Organizational citizenship behaviour and workplace deviance: The role of affect and cognitions. *Journal of Applied Psychology*, 87, 131–142.
- Li, R., Zhang, Z.-Y., & Tian, X.-M. (2016). Can self-sacrificial leadership promote subordinate taking charge? The mediating role of organizational identification and the moderating role of risk aversion. *Journal of Organizational Behavior*, 37, 758–781.
- Lykken, D. T. (1968). Statistical significance in psychological research. *Psychological Bulletin*, 70, 151–159.
- Martin, R., Guillaume, Y., Thomas, G., Lee, A., & Epitropaki, O. (2016). Leader-member exchange (LMX) and performance: A meta-analytic review. *Personnel Psychology*, 69, 67–121.
- Matteson, J. A., & Irving, J. A. (2006). Servant versus self-sacrificial leadership: A behavioral comparison of two follow-oriented leadership theories. *International Journal of Leadership Studies*, 2(1), 36–51.
- McKenna, R., & Brown, T. (2011). Does sacrificial leadership have to hurt? The realities of putting others first. *Organization Development Journal*, 29(3), 39–50.

- Miao, Q., Newman, A., Schwarz, G., & Xu, L. (2013). Participative leadership and the organizational commitment of civil servants in China: The mediating effects of trust in supervisor. *British Journal of Management*, *24*, S76–S92.
- Nahapiet, J., & Ghosal, S. (1998). Social capital, intellectual capital, and the organizational advantage. *The Academy of Management Review*, *23*(2), 242–266.
- Paillé, P., Mejía-Morelos, J. H., Marché-Paillé, A., Chen, C. C., & Chen, Y. (2016). Corporate greening, exchange process among co-workers, and ethics of care: An empirical study on the determinants of pro-environmental behaviours at coworkers-level. *Journal of Business Ethics*, *136*(3), 655–673.
- Parzefall, M.-R., & Kuppelwieser, V.-G. (2012). Understanding the antecedents, the outcomes and the mediating role of social capital: An employee perspective. *Human Relations*, *65*(4), 447–472.
- Pastoriza, D., & Arino, M. A. (2013). Does the ethical leadership of supervisors generate internal social capital? *Journal of Business Ethics*, *118*, 1–12.
- Pastoriza, D., Arino, M. A., & Ricart, J. E. (2008). Ethical managerial behavior as antecedent of organizational social capital. *Journal of Business Ethics*, *78*(3), 329–341.
- Pastoriza, D., Arino, M. A., & Ricart, J. E. (2009). Creating an ethical work context: A pathway to generate social capital. *Journal of Business Ethics*, *88*, 477–489.
- Pirlott, A. G., & MacKinnon, D. P. (2016). Design approaches to experimental mediation. *Journal of Experimental Social Psychology*, *66*(1), 29–38.
- Podsakoff, P. M., MacKenzie, S. B., Lee, J.-Y., & Podsakoff, N. P. (2003). Common method biases in behavioural research: A critical review of the literature and recommended remedies. *Journal of Applied Psychology*, *5*, 879–903.
- Podsakoff, P. M., MacKenzie, S. B., & Podsakoff, N. P. (2012). Sources of method bias in social science research and recommendations on how to control it. *Annual Review of Psychology*, *63*, 539–569.
- Preacher, K. J., & Hayes, A. F. (2004). SPSS and SAS procedures for estimating indirect effects in simple mediation models. *Behavior Research Methods, Instruments, and Computers*, *36*(4), 717–731.
- Sachdeva, S., Iliev, R., Ekhtiari, H., & Dehghani, M. (2015). The role of self-sacrifice in moral dilemmas. *PLoS ONE*, *10*(6), e0127409. <https://doi.org/10.1371/journal.pone.0127409>.
- Samnani, A.-K., Salamon, S. D., & Singh, P. (2014). Negative affect and counterproductive workplace behaviour: The moderating role of moral disengagement and gender. *Journal of Business Ethics*, *119*(2), 235–244.
- Schmidt, S. (2009). Shall we really do it again? The powerful concept of replication is neglected in the social sciences. *Review of General Psychology*, *13*, 90–100.
- Singh, N., & Krishnan, V. R. (2008). Self-sacrifice and transformational leadership: Mediating role of altruism. *Leadership and Organization Development Journal*, *29*(3), 261–274.
- Spencer, S. J., Zanna, M. P., & Fong, G. T. (2005). Establishing a Casual Chain: Why Experiments are Often More Effective than Mediation Analyses in Examining Psychological Processes. *Journal of Personality and Social Psychology*, *89*(6), 845–851.
- Turnipseed, D. L. (2008). Are good soldiers good? Exploring the link between organization citizenship behaviour and personal ethics. *Journal of Business Research*, *55*, 1–5.
- van Dierendonck, D. (2011). Servant leadership: A review and synthesis. *Journal of Management*, *37*(4), 1228–1261.
- van Knippenberg, B., & van Knippenberg, D. (2005). Leader self-sacrifice and leadership effectiveness: The moderating role of leader prototypicality. *Journal of Applied Psychology*, *90*, 25–37.
- Walumbwa, F. O., Mayer, D. M., Wang, P., Wang, H., Workman, K., & Christensen, A. L. (2011). Linking ethical leadership to employee performance: The roles of leader–member exchange, self-efficacy, and organizational identification. *Organizational Behaviour and Human Decision Processes*, *115*(2), 204–213.
- Wayne, S. J., & Green, S. A. (1993). The effects of leader–member exchange on employee citizenship and impression management behaviour. *Human Relations*, *46*(12), 1431–1440.
- Williams, L. J., Vandenberg, R. J., & Edwards, J. R. (2009). 12 structural equation modeling in management research: A guide for improved analysis. *The Academy of Management Annals*, *3*(1), 543–604.
- Yukl, G. A. (1989). *Leadership in organizations*. New Jersey: Prentice Hall.
- Zhao, X., Lynch, J. G., & Chen, Q. (2010). Reconsidering Baron and Kenny: Myths and truths about mediation analysis. *Journal of Consumer Research*, *37*(2), 197–206.