

JOHN WILLATS and FREDO DURAND

DEFINING PICTORIAL STYLE: LESSONS FROM LINGUISTICS AND COMPUTER GRAPHICS

ABSTRACT. A definition of pictorial style in terms of distinctive combinations of pictorial devices characteristic of a particular culture or period or the work of an individual artist is proposed. Four kinds of pictorial structure are described: the drawing (spatial) systems, the denotation systems, the mark systems and the attributes systems. Three pictures by Poussin, Rembrandt and the Achilles painter are then analyzed in terms of these four systems. It is suggested that descriptions of style of this kind can be thought of as hypotheses about the nature of the implicit rules that generated the pictures to which they were applied. Examples of ways of testing this suggestion by embodying such stylistic rules in computer graphics programs are given.

1. INTRODUCTION

The term ‘style’ as applied to pictures has been used in many different ways, ranging from its application to features of pictures belonging to whole cultures or periods to the works of individual artists. The different categories to which it has been applied have also varied very widely. These include aesthetic categories, such as the beautiful, the sublime and the picturesque, and different modes of representation related to different techniques or motifs. In Greek vase painting, for example, the term ‘geometric style’ refers to the inclusion of geometric patterns, and the term ‘orientalizing style’ to the inclusion of exotic motifs derived from the Orient, while the terms ‘black-figure style’ and ‘red-figure style’ are derived from the different colours of the silhouettes. As Gombrich (1960/1988) has pointed out, the terms used to describe style often depend on metaphor: the ‘hard’ style of archaic sculpture contrasted with the ‘softness’ and ‘sweetness’ of fourth-century sculpture.

The term ‘style’ has also been applied to different ways of seeing the world. In *Art and Illusion* Gombrich (1960/1988) began his chapter on the ‘riddle of style’ by asking: ‘Why is it that different ages and different nations have represented the visible world in such different ways? Will the paintings we accept as true to life look as

unconvincing to future generations as Egyptian paintings look to us? (p. 3). Thouless (1933) suggested that the difference between the styles of Western and Oriental art might be due to racial differences in visual perception. Differences in pictorial style have also been considered to carry moral connotations: when Winckelmann first applied categories of style to the history of art he equated the plain and humble style of Greek art with untroubled innocence and moral restraint, while Baroque art was equated with the stilted, affected and degenerate. In these circumstances it is not perhaps surprising that there is no very general agreement about what constitutes pictorial style, and as a consequence the terms used to define style have not been very precisely defined.

2. STYLE IN LANGUAGE

Many of the terms used to describe pictorial style have been derived from attempts to describe style in rhetoric or natural language. Demetrius, in his first-century textbook *On Style* recommended the use of expressions with a harsh or unpleasant sound when describing a rugged or formidable subject matter. The use of a particular style was also associated in rhetoric with particular social settings – ‘boy meets girl’ would be a humble style, while ‘youth meets maiden’ is more noble. Similarly, in modern linguistics, style has been related to the use of language in a particular social context: the style of language used in the law courts is very different to that used in the playground. The style of language used in scientific journals is precisely defined and the rules of this style have to be learned. These range from the avoidance of the use of the first person to the detailed rules for citations. The use of the passive tense is more common than it would be in other kinds of writing.

Stylistics, as a branch of general linguistics, is generally applied to the study of literary style in prose and poetry. In this interpretation style has to do with those components or features in the form of a literary composition which give to it its own individual stamp, marking it out as the work of a particular author. These components can include all aspects of linguistic structure, from syntax through semantics to phonology and phonetics, and some linguists have suggested that a defining characteristic of poetry and poetic speech is the use of unusual or anomalous grammatical structures for expressive purposes (Thorne, 1972).

Thus in modern linguistics the notion of style has come to be associated with the use of specific linguistic structures. This suggests that, as in language, style in pictures might be defined in terms of distinctive combinations of pictorial devices or structures characteristic of a particular culture or period or the work of a particular artist.

As Noam Chomsky (1957/1965) pointed out, all native speakers of a language can immediately, and without conscious effort, recognize which sentences are grammatical, which are ungrammatical and which are ambiguous. Similarly, at the level of individual words, speakers can recognize that 'brick' is an English word, that 'blick' is not an English word but could be, and that 'bnick' is not an English word and could not be one (Moskowitz, 1978). Recognizing such differences depends on an implicit knowledge of the rules of language, although such rules normally only operate at an unconscious level. Early work on the analysis of pictures was influenced by this approach, and Huffman (1971), among others, showed that our intuitions about whether line drawings are 'grammatical' or 'ungrammatical' – that is, whether or not they represent possible objects – can be shown to correspond to explicit rules about the ways in which lines and line-junctions may and may not be combined. Might not this same approach be applied to the analysis of style in pictures? Most people can to a greater or lesser extent recognize stylistic differences among different schools of painting or the works of individual artists, and the analogy with language suggests that recognizing these differences might depend on an implicit knowledge on our part of the pictorial rules that generated these pictures. How can we make these rules explicit?

3. THE RULES OF REPRESENTATION

Defining style in terms of precise pictorial structures is, from a scientific point of view, still very much in its infancy. Precursors can perhaps be found in Wölfflin's (1932) attempt to define the styles of European painting in the 15, 16 and 17th centuries in terms of five pairs of categories: linear and painterly, plane and recession, closed and open forms, multiplicity and unity, and clearness and unclearness, and in schemes such as those described by White (1967) and Hagen (1986). A more recent account (Willats, 1997) has described the rules of representation in terms of three broad categories: the *drawing* or *spatial systems*, that map spatial relations in the scene into

corresponding spatial relations on the picture surface; the *denotation systems*, that map scene primitives into picture primitives; and the *mark systems* that map picture primitives into physical marks such as blobs of ink or areas of paint. Durand (2002) has added a fourth category: the *attributes system* that defines the attributes and properties (such as thickness, spatial scale and colour) of the elements that make up the denotation and mark systems.

As with all scientific endeavours these definitions depend on the use of a precise terminology. Some of the terms used – the term ‘primitives’ for example – will be unfamiliar to some readers. Others, such as ‘pictures’ and ‘contours’ will be familiar but are used in a precise way – just as in the early days of physics the common terms ‘mass’ and ‘weight’ were distinguished and given a precise meaning. The use of this precise terminology is difficult but crucial, and it is particularly important to distinguish carefully between the words used to describe features of real or hypothetical 3D *scenes* and representations of such scenes in 2D *pictures*. The terminology used here has been taken from a number of different sources including engineering drawing, vision science, artificial intelligence and computer graphics.

Recognizing objects in either pictures or scenes depends primarily on shape recognition, and this is one of the most important functions of the human visual system. A very broad distinction can be made between representational pictures, in which shape and space can be seen in the picture (Wollheim, 1977/1987) and non-representational pictures. Colour is less important than shape for object recognition but is important in pictures for other reasons.

Probably the most influential account of shape recognition is still that given by David Marr (Marr, 1982; Palmer, 1999). According to Marr all schemes for representing shape and space (and this includes pictures as well as scenes) must have at least two components: a *coordinate system*, and *primitives*. One example of a *coordinate system* would be Cartesian coordinates, widely used in computer programs for defining the shapes of objects, but other less formal systems are used by human beings: we might describe the shape of a table, for example, in terms of the spatial relations between its component parts. The *primitives* of a system are the atomic units available in the system, they are the building blocks that will be used to describe more complex objects. In a system of Cartesian coordinates these units would be, for example, zero-dimensional primitives or points, such as the corners of a table, or the line junctions representing these corners in a picture.

Thus the representation of shape in pictures can be described in terms of two basic representational systems: the drawing (or spatial) systems and the denotation systems. The *drawing (spatial) systems*, of which linear perspective is one common example, map spatial relations in the scene into corresponding spatial relations on the picture surface, while the *denotation systems* map scene primitives into corresponding picture primitives (Willats, 1997/2002a). In Canaletto's line drawing in perspective of the *Campo di SS. Giovanni e Paolo*, for example, most of the one-dimensional picture primitives or *lines* denote the edges of buildings, while in his painting of the same subject the *picture primitives* are zero-dimensional points that denote the tones and colours of (continuous) zero-dimensional *scene primitives* derived from the array of light coming from the scene (Kemp, 1992; Willats, in press).

Together, the drawing (spatial) systems and the denotation systems provide a way of classifying the representational systems in a very wide range of pictures and therefore form a basis for describing at least part of what we mean by pictorial style.

There are five main classes of drawing (spatial) systems: perspective; the parallel oblique systems of which the commonest is oblique projection; orthogonal projection; inverted perspective; and systems based on topological geometry rather than projective geometry. Of these systems perspective is probably the best known, as it provided the basis for nearly all Western painting from the beginning of the Renaissance until the 20th century as well as pictures produced by optical means such as the camera. Pictures can be recognized as being in perspective when there is a change of scale with distance and the orthogonals (lines representing edges in the third dimension of the scene) converge to a vanishing point. In contrast, there is no change of scale with distance in pictures in oblique projection, and the orthogonals are parallel and run obliquely across the picture surface. Historically, oblique projection has probably been the most commonly used of all the drawing systems. It formed the basis for most Oriental paintings and drawings and is also found in Mediaeval art and 18th and 19th century technical drawings. One of its variants, axonometric projection, was probably the commonest system used in Cubist paintings. Confusingly, there are no orthogonals in orthogonal projection, the drawing system used in most Greek vase paintings. It was widely used in the Mediaeval period (for e.g., in the Bayeux tapestry) and is now universally used for engineers' and architects' working drawings. So-called inverted perspective, in which the

orthogonals diverge, was characteristic of Byzantine art and Russian icon painting. Finally, many cartoons and caricatures draw on topological rather than projective geometry, and this system was used by a number of 20th-century artists including Paul Klee (Willats, 1997).

Identifying these drawing (spatial) systems in pictures can thus provide a very coarse-grained classification system for recognizing styles of painting from different periods and cultures. However, each of these systems has its variants. The perspective systems used by the early Italian painters are much less strict than the versions used by later European painters, and other factors can also vary. Giotto frequently used a mixture of different kinds of perspective, for example, whereas in Canaletto's paintings the representation of space is much more unified. The notional distance of the spectator from the scene and the depth of field can also vary from one style of painting, or one painter, to another. Much 18th century Neoclassical painting is characterized by the use of a long spectator distance, a narrow angle of vision and a shallow field of focus, providing an approximation to orthogonal projection in which the scene is shown at eye level from an infinite distance away. Saenredam's *The Grote Kerk at Haarlem* (1595–1665) employs an exceptionally wide angle of view (Carter, 1967; Dubery and Willats, 1972). In *Vincent's Room*, 1888 Van Gogh used a version of perspective (that White (1967) called 'synthetic' perspective) in which the scene is depicted as if it were projected on to a cylindrical picture plane (Dubery and Willats, 1972). The recognition of such variants allows us to recognize one aspect of the styles of painting characteristic of particular schools of painting in different countries and periods in European art, and the style of individual artists, and even the style employed by individual artists at different periods in their development.

However, the recognition of different denotation systems is just as important a factor in the analysis of style. The three main denotation systems are defined, respectively, in terms of zero-, one- and two-dimensional picture primitives. In optical systems the scene primitives are points representing the intercepts of light rays as they reach the camera or eye of the spectator. The hues and intensities of these scene primitives vary over the continuous optic array (Durand, 2002) and these continuous scene primitives may be denoted by continuous or virtually continuous point primitives in the picture. In actual physical pictures, however, the picture primitives are usually represented by discrete *marks* which can vary greatly in size. In pointillist paintings,

for example, the marks (dots of paint) are relatively large, whereas in photographic prints the marks (minute grains of pigment) are usually very small.

In line drawings the picture primitives are one-dimensional lines. As Kennedy (1974/1983) has pointed out the lines in line drawings can stand for or denote a variety of different features in the scene, including: edges, such as the edges of buildings; the occluding contours of smooth forms such as drapery or much of the human figure; thin, wire-like forms such as hair; cracks, such as the cracks between the edges of a door and its frame; and creases. In addition, lines are often used to denote the boundaries between areas which differ in their local tones or colours. Lines are not generally acceptable, however, when used to stand for the boundaries of shadows or highlights.

The relation between the lines in a line drawing and the array of light from a scene is a complex one. According to J.J. Gibson, 'there is no point to point correspondence of brightness or color between the optic array from a line drawing and the optic array from a scene.' (Gibson, 1971, p. 28). Certainly, early attempts to obtain line drawings from grey-scale images automatically, by scanning photographs and representing the abrupt changes in tone ('luminance steps') by lines, are not very convincing (Marr, 1982). However, more recent research (Pearson et al., 1990) showed that quite respectable line drawings can be obtained by using what they called a 'cartoon operator' tuned to pick out a combination of luminance steps and luminance valleys.

Another important aspect of the denotation systems in line drawings is that some of the picture primitives may denote scene primitives that form part of an object-centered description (Marr, 1982) while others may denote features that can only belong to viewer-centered descriptions. (Object-centered shape descriptions are based on the objective features and layout of 3D scenes and are given independently of any point of view. Viewer-centered descriptions describe objects and scenes as seen from some points of view.) Thus lines can be used to stand for *edges* that are physically present in scene such as the edges of a building, but they can also be used to stand for *contours*: the projection in the visual field of the locus of points where the line of sight just grazes the surface of a smooth form (the 'rim'). This distinction seems to have a developmental component: quite young children will use line junctions to denote the corners belonging to rectangular objects, but only older children use line-junctions to denote points of occlusion in the visual field.

In a third class of denotation systems the picture primitives are two-dimensional *regions*. In drawings by very young children, such as the well-known ‘tadpole’ figures, these regions are used to stand for whole volumes, while slightly older children will use regions to stand for the faces of rectangular objects such as cubes (Willats, 1997). Finally, regions can also be used to stand for regions in the visual field, a system found in the early Greek vase drawings but also in drawings and paintings by Picasso and Matisse. In these examples it is important to realize that the shapes of the boundaries are not significant; it is only the shapes of the regions as a whole that carry the meaning (Willats, 1992a, b).

Picture primitives and scene primitives are abstract concepts. In practice, picture primitives are represented in paintings, drawings, tapestries, mosaics, engravings and so on by physical *marks*. This distinction is analogous to that made in language between the smallest units of meaning – phonemes and morphemes – and their realization in physical sounds or letters. In addition to their extensions in zero, one or two dimensions marks can have a great variety of *attributes*. Attributes include colour, tone, transparency, texture, thickness, ‘wiggling’ and orientation (Durand, 2002). Another important factor in the use of marks is the extent to which they may be tightly or loosely controlled. According to Philip Rawson:

The blob is a mark in which chance plays the dominating part.... the appearance of the blob intrinsically represents the element of hazard in drawing technique. Some styles exile hazard and the blob completely. Others may cultivate it expressly. For example, the ‘po-mo’ technique of the Chinese painters of the Sung Dynasty, and later Chinese and Japanese epochs, cultivated ‘spilled ink’ as a stimulus to invention. Literal ‘puddles’ of ink would be teased with the brush into suggestive shapes. J.R. Cozen’s blot landscapes also began in the same way. Jackson Pollock and many other Abstract Expressionists elaborated the use of the blob into a system.

Rawson (1987), p. 81.

The relations between the marks and their attributes and the picture primitives they represent can also be very varied. The dimensional extensions of the marks may not always correspond to those of the primitives they represent: in a mosaic or a tapestry, for example, groups of zero-dimensional tesserae or stitches may be used to denote one dimensional lines. In some cases the primitives may not even be physically represented – in some cartoons, for example, the line junctions which may be the most important units of meaning may only be implied (Willats, 1997).

Thus the number of possible combinations of drawing systems, denotation systems, mark systems and their attributes is very large indeed – large enough one would think to encompass the very wide range of styles realized in actual pictures. Out of all these possible combinations only three pictures will be analyzed here. Two of these, Poussin's drawing for *The Rape of the Sabines* and Rembrandt's *Child Being Taught to Walk* are both European and come from much the same period. The third, *Leave-taking* by the Achilles painter is taken from a 5th century Greek vase painting. All three are, in effect, line drawings. Intuitively, the styles of these three drawings are very different, but although Poussin and Rembrandt are both normally classed as Baroque painters the style of the Poussin drawing seems in many ways rather more similar to that of the Greek vase painting than it does to the Rembrandt. On what formal properties of pictures might such judgements be based?

4. THE DRAWING SPATIAL SYSTEMS

The drawings by Poussin (Figure 1) and Rembrandt (Figure 2) are both in perspective. There are no definite clues in either of these drawings that enables us to fix the exact position of the viewpoints from which they were notionally taken, but the implied distances of the viewer from the scene look rather similar. The eye level in the Rembrandt drawing (corresponding to the height of the viewer's eye above the ground plane) appears to be at or just above the child's head, whereas that in the Poussin drawing appears to be rather higher: at or just above the woman's head. Accordingly, the ground plane in the Rembrandt drawing is at a slight slant to the viewer's line of sight, whereas the implied slant of the ground plane in the Poussin drawing is somewhat greater.

At first glance the Greek vase drawing shown in Figure 3 might also appear to be in perspective, an impression given by the precise foreshortening of the chair and the shield, but in fact this drawing is in orthogonal projection. As a result, everything in the scene is shown as if from eye level. The ground plane is parallel to the viewer's line of sight and is represented by a single line at the bottom of the drawing.

5. THE DENOTATION SYSTEMS

There are two denotation systems involved in the Poussin drawing; they are clearly differentiated and easy to distinguish from one



Figure 1. Nicholas Poussin (1594–1665), Drawing for *The Rape of the Sabines*. Pen and wash over black chalk, 11 × 8 cm. The Royal Collection © 2003, Her Majesty Queen Elizabeth II.

another. The first system is straightforward, classic line drawing in which the lines denote the occluding contours of smooth forms. There are no thin, wire-like forms, cracks, puckers, wrinkles or other surface discontinuities in the depicted scene and, unusually, no use of lines to denote edges. In fact, the drawing provides an example in which the lines follow a simplified version of the rules for line drawings of possible smooth three-dimensional forms described by Huffman (1971) in the context of artificial intelligence. There are numerous clearly articulated T-junctions denoting points of occlusion where one surface just disappears behind another, and several end-junctions denoting the points where contours end within the form. One important rule for line drawings described by Huffman is that if a line drawing is to depict a possible form no line segment must change its ‘meaning’ along its length; violating this rule can result in drawings of ‘impossible objects’ such as the well-known ‘devil’s pitchfork’. An exception to this rule which is not uncommon in



Figure 2. Rembrandt van Rijn, *Child Being Taught to Walk*, 1660-2. Pen and sepia, 9.3 × 15.2 cm. © Copyright British Museum.

complex drawings, and is usually quite acceptable, often occurs at points where one smooth form just overlaps another. One instance of this occurs in the Poussin drawing where the man's hand just embraces the woman's waist. Above this point the occluding surface lies to the left of the contour, and below it to the right of the contour and it is perhaps noteworthy that the line breaks just at this point. Other than this there are no anomalies in the drawing. There is even a small concave tick at the end-junction marking the point where the forms divide at the woman's buttocks, correctly following a rule described by Koenderink and van Doorn (1982) that the visible contour must be concave to the occluding surface at an endjunction, denoting a saddle-shaped patch at this point on the surface. Thus although the forms of the lines in the drawing appear fairly casual they are conceptually strictly controlled.

The second denotation system in this drawing is optically based and consists of two related systems depicting, respectively, tonal modeling and cast shadow. There is little or no variation in the tone of the picture primitives. Thus the continuous system of zero-dimensional scene primitives derived from the light falling on the scene is represented in this drawing by more or less uniform regions of tone.



Figure 3. Achilles painter, *Leave-taking*, middle of the fifth century B.C. White-ground style, from a tomb lekythos. Athens, National Museum.

The spatial relations between these regions on the picture surface are best described in terms of the topological properties of spatial order, proximity, separation and attachment. The figures of the man and the woman are identified by lines representing their contours, and in some places, as Rawson (1987) points out, the areas of tone run across these boundaries joining the figures together on the picture surface. In other places, however, the figures are separated, most notably by the long, thin area of light tone that divides the man's belly from the woman's belly and upper thigh. The arrangement of regions of light and dark tones on the picture surface thus carries an important part of the meaning of the drawing: the man is holding the woman to him and she is struggling to get away.

This is reinforced by the relations between the contours of the figures, the regions denoting tonal modelling, and the region of cast shadow. Waltz (1975), in his analysis of line drawings of scenes with shadows, pointed out that pure line drawings are often ambiguous. In Figure 4(a), for example, the cube on the left could be resting on a surface or floating in mid air. The addition of cast shadows in a picture can be, and in artists' pictures often is, used to remove such

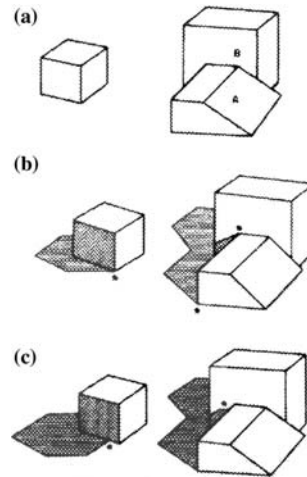

Figure 4. Line drawings with shadows. (a) There is no evidence to relate the objects to each other or to the surface on which they are resting. (b) The objects must be touching each other and the surface on which they are resting at the points marked by asterisks. (c) The objects and the surface on which they are resting are *not* touching at the points marked by the asterisks. Taken from Waltz (1975), courtesy of McGraw-Hill, Inc.

ambiguities. In Figure 4(b) the attachment on the picture surface between the region of tone on the vertical face of the cube and the region of cast shadow at the point marked by an asterisk, together with the shape of the region of cast shadow, shows that the cube is resting on a horizontal surface. Similarly, from the attachments between the contours of the wedge-shaped block and the areas of cast shadow, also marked with asterisks, we infer that these blocks are touching and that the wedge-shaped block is resting on a horizontal surface. In contrast, the cube shown in Figure 4(c) must be floating in mid air and the blocks are not touching.

This suggests a simple pictorial rule: if a point on a contour representing a corresponding point on a surface in the scene touches the boundary of a region of cast shadow representing that point the two points must be in contact. The application of this rule to the conjunction of the light and dark regions at the man's right heel and the line representing the contour of this heel in the Poussin drawing shows that the heel must be touching the ground at this point. The Gestalt principle of good continuation between the long thin region of cast shadow at this point and the line representing the sole of the foot suggests that the entire foot is resting on the ground.

The relations between the lines and regions surrounding the man's left leg and foot are more complex. The conjunction of the tiny blob of tone at the tip of the toe and the contour of the toe suggests that the toe is touching the ground at this point, and the good continuation between the line perhaps representing the cast shadow of the leg and the line representing the contour of the ball of the heel suggests that the whole toe is resting on the ground. The three thin areas of light tone, two within the contour of the lower leg and one outside it, show that this part of the leg is separated in threedimensional space from the area of cast shadow behind it. The contour of the heel is surrounded by a dark tone on either side so that at this point the drawing is ambiguous, like the drawing of the cube in Figure 4(a), but the shape of the foot suggests that the heel may be slightly raised. This in turn suggests that much of the man's weight and most of the woman's weight it being carried on his right foot.

In contrast, the separation on the picture surface between the contours of the woman's legs and the area of tone between the man's legs representing their cast shadows shows that the woman's legs are raised high in the air. Again, the topological relations of attachment and separation between the contours of the forms and the regions of tonal modelling and cast shadow are used to carry the meaning of the drawing: the man's determination and the woman's struggles to get away. Thus the formal properties of the picture primitives and the relations between them, apparently rather artless, are in fact beautifully contrived.

The Greek vase painting *Leave-taking* is, like the Poussin drawing, based on two main denotation systems but here the areas of tone depict not tonal modelling or cast shadow but *local* tone – the intrinsic properties of tone or colour in an object-centered scene description. The use of lines to denote occluding contours is very similar to that in the Poussin drawing and there is the same precise use of T-junctions and end-junctions to denote the points of occlusion. In addition, however, lines are also used to denote edges, such as the edges of the woman's sandals and the bottom of the man's tunic, thin forms such as the man's spear and the lashes of the large eye on the shield, and creases, such as the creases at the man's wrist. More unusually, the X-junctions where two lines cross are used to show the transparency of the clothing. The variety of meanings carried by the lines is therefore more complex than it is in the Poussin drawing.

The areas of tone play a less important part in the composition. The figures are related to each other by lines rather than by the connections between regions, and these lines are not physically present in the composition but are implied, partly by the dispositions of the most important features of the picture and partly by the eye directions of the man and the woman (Willats, 1997). The most important of these is the implied horizontal line that connects the woman's eye to the corner of the large eye on the shield, just grazing the top of the curved area of local tone on the crest of the helmet. Baron-Cohen et al. (1995) have shown that eye direction can be a powerful indicator of mental states, and that by the age of 3 or 4 years most children know that if a person is looking up or away that person is preoccupied with their own thoughts. The emotional sadness of this drawing – and that of other drawings on tomb lekehoi – is expressed in part by the way in which the participants in this leave-taking fail to meet each others' gaze, and are absorbed in their own thoughts.

Rembrandt's drawing of a child being taught to walk is also based on two main denotation systems: line drawing, and areas denoting tonal modelling and cast shadow. Instead of these systems being depicted separately, however, as they are in the Poussin drawing, they are run together in the Rembrandt drawing so that it is difficult to separate them conceptually. The areas of tone at the boundaries of the silhouettes suggest tonal modelling, but are so completely integrated with the lines denoting occluding contours that the burden of the depiction of form that each system carries can hardly be distinguished. Moreover, the T – and end-junctions, instead of being clearly articulated are largely implied. The most obvious example of this is that the right-hand contours of the dress of the standing woman on the left, and the contours of the pail, stop short before they reach the contours of the crouching figure below. This has the effect of separating the standing woman from the group round the child in spatial depth, and in terms of the geometry of the picture surface separates this woman from the action of the painting: she is looking on while the others are engaged with the child.

6. THE MARK SYSTEMS AND THE ATTRIBUTE SYSTEMS

The main differences among the mark systems employed in these three drawings lie in the different thicknesses of the lines and the part played

by chance – or ‘hazard’ as Rawson calls it – in representing the picture primitives. In the Poussin drawing the lines are of virtually uniform thickness throughout. The detailed shapes of the lines allow something to chance, but allowance must be made for the fact that this is a sketch for a finished painting: the marks in Poussin’s paintings are normally highly controlled. The washes of tone appear to be applied quite casually, but as we have seen this is rather deceptive and the places where the boundaries of these areas of tone fail to reach the contours or overlap them are in fact carefully contrived. In contrast the lines in *Leave-taking* vary a good deal in thickness and the marks throughout are very precisely controlled, even by the standards of other vase paintings from this period. The variations in line thickness are used for several different purposes. In general, thicker lines are used for the outer boundaries of the figures, perhaps harking back to the emphasis on silhouette in the earlier figures of the red-figure style. In a few places the variations in thickness along the line almost seem to suggest tonal modelling along the contours of the form, rather in the manner of Edgar Degas’ drawings of ballet dancers – an unusual feature of Greek vase paintings. The thin lines of the drapery are also used to suggest transparency.

In the Rembrandt drawing the variations in line thickness and tone are so extreme, and the element of apparent hazard so great, as almost to suggest a comparison with Chinese brush painting. Perhaps the main effect of this is to emphasize the physical nature of the picture surface. As Rawson remarked:

In most of the world’s best drawings a very large part of their vigour and expression derives from a kind of tension or conflict between the two-dimensional and the three-dimensional... in those drawings which are universally recognized as masterpieces there is a vigorous conflict between a highly developed two-dimensional surface unity, and a highly-developed three-dimensional plasticity. The higher the point to which both are developed the stronger the drawing.

Ibid., p. 79.

7. DESCRIPTIONS OF STYLE AS HYPOTHESES ABOUT IMPLICIT RULES

Descriptions of pictorial style such as those given above are in effect hypotheses about the nature of the implicit rules generating the pictures to which they have been applied. The value of such hypotheses lies ultimately in their explanatory power: the insights they might give

into the mental processes by which pictures are produced and the styles adopted by their producers within the context of art history. One way of testing such hypotheses might be to use these rules within computer graphics programs.

Computer graphics offers unprecedented opportunities to explore the picture creation process. Art training has heavily – and successfully – relied on teaching by example, where the rules of depiction do not need to be explicit and where metaphors are often used. In contrast, programming a computer to synthesize images requires a systematic and explicit formulation of procedures, usually in the form of a programming language. This makes crucial the precise definition of the objects and concepts manipulated, and it encourages the organization of depiction into well-identified sub-tasks and explicit rules.

Consider the related example of vision. The complexity of seeing was mostly overlooked until computer scientists and researchers in artificial intelligence attempted to build computers that can see. They quickly realized that the endeavor was far more intricate and formidable than was foreseen, and that the task had to be organized in a principled way and decomposed into sub-tasks. The framework proposed by David Marr (1982) not only strongly influenced the field of artificial intelligence; it also shed a new light on the study of human vision. It provided a solid vocabulary and a new perspective on vision as information processing, that is, how the optical information reaching the retina is progressively transformed and interpreted to achieve an understanding of the world around us. A well-established reference on visual perception such as the book by Palmer (1999) is now organized along an updated version of Marr's pipeline. We hope that computer graphics can offer similar insights into the process of picture creation.

In addition, digital image synthesis can facilitate the exploration of styles and transcriptions. A computer can generate many renditions of the same 3D scene with different parameters.

7.1 From the old quest for photorealism to the new quest for non-photorealism

As with the development of style in artists' pictures, the evolution of style in computer graphics has resulted from the tension between varying goals and technical limitations. Interestingly, these limitations have not followed the same pattern as the challenges faced by human artists. The availability of a vast body of knowledge,

accumulated in particular after the Renaissance, has clearly spared image synthesis a number of deadlocks that took artists centuries to solve. But in addition, the fundamentally different natures of humans and computer make them proficient at different tasks. Computers are extremely efficient for numerical computation, but programming them for more qualitative tasks is much more involved, usually because the issue is hard to characterize formally.

Early computer graphics focused on line drawing denotations systems, mostly because of the limited capacity of computers and display device. Isolated lines are cheaper to represent and process than the entire optical array. With the increasing availability of memory and processing power, the optical denotation system became predominant, with the introduction of TV-like monitors. This evolution was accentuated by a change in the goals and applications of the field, with a shift from engineering Computer-Aided Design and flight simulation where the geometry of the scene was paramount, to photorealistic rendering for the entertainment and special effect industry, where appearance and the illusion of reality are crucial. Computer graphics has thus long been defined as a quest towards 'photorealism', that is, the generation of images that are undistinguishable from photographs of real scenes. This has been encouraged by the Western pictorial tradition, and has provided a clear goal that made the image synthesis problem easy to state, if not to solve.

Just as the Holy Grail of photorealism seems within reach the field is discovering that photorealism is not always the most appropriate representation system. Other styles can provide clearer shape representation, remove clutter or be more aesthetically pleasing. Over the last decade, a new sub field called Non-Photorealistic Rendering (NPR) has emerged that attempts to imitate the qualities of traditional media such as oil painting or pencil drawing (Schlechtweg and Strotthote, 2002; Gooch and Gooch, 2001; Durand, 2002). A negative definition of a field is always an indication of unclear domain of study and goals, and non-photorealistic rendering is no exception. The broad variety of styles afforded by traditional media and the plethora of goals and contexts that drive picture creation make non-photorealistic depiction harder to organize and characterize than its photorealistic counter- or sub-part. We believe that the coarse-grained organization of style into different representation systems discussed in this article can provide a solid framework to gain perspective about this new field.

In the rest of this article, we discuss traditional computer graphics techniques, which use an optical denotation system and result in rather realistic images, before discussing systems that produce more stylized pictures. These different computer graphics styles illustrate how the framework discussed in the previous sections captures a coarse-grained description of style. While the subdivision of depiction into the four systems discussed in this paper (drawing(spatial), denotation, attribute and mark) has not yet become a standard taxonomy in computer graphics, we believe that it captures well the organization of computer graphics techniques (Durand, 2002).

7.2 *The traditional graphics pipeline*

The thriving achievements of computer graphics over the last decades can be in large part credited to a clear decomposition of image generation into a well-identified set of sub-tasks. This organization made it easy for new techniques to be plugged very quickly into existing systems, allowing for a fast pace of improvement. Image generation has been organized along the so-called *graphics pipeline*. It takes as input the description of a 3D scene in object space, and produces, for a given viewpoint, an image that consist of a raster of pixels (or picture elements). As we will see, the series of operations necessary to transform the 3D objects into a 2D image are closely related to the elements of representation systems.

The most popular object-space representation for 3D objects is polygonal meshes. The surface of objects is represented as a connected set of polygons, and if the tessellation is fine enough, the approximation looks smooth. The basic primitive used in this representation is a polygon in 3D space, often a triangle. It is encoded by the Cartesian 3D coordinates (x, y, z) of each vertex, which means that a triangle can be stored in memory using nine numbers $[(x_1, y_1, z_1), (x_2, y_2, z_2), (x_3, y_3, z_3)]$.

The 3D coordinates of objects in the scene first have to go through a series of mathematical equations that rule the projective transform. This constitute the drawing(spatial) system of traditional computer graphics (Figure 5). Given the location of the viewpoint and the field of view, the 2D coordinates of each projected vertex can easily be computed using well-known formulae. The same family of equations leads to linear perspective, orthographic projection, or oblique projections, because they all preserve straight lines. These are usually the

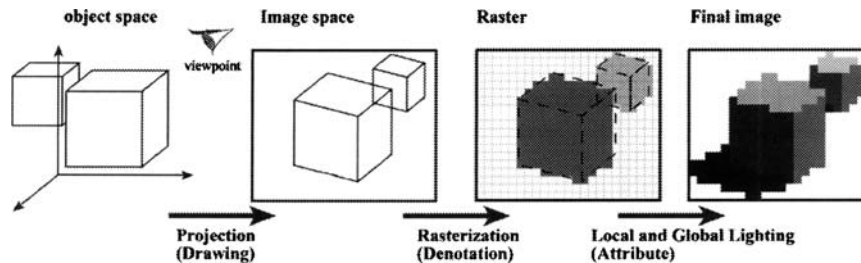

Figure 5. The traditional computer graphics pipeline.

only drawing systems used in computer graphics, although non-linear systems have been studied as well, as will be discussed later. In contrast to the long effort that was necessary for human artist to develop linear perspective, and in contrast to the large part it usually takes in the teaching of drawing, projection has been a very minor difficulty in computer graphics. This is partly due of course to the availability of the previously developed knowledge, but also to the fact that projection is a purely quantitative task. It simply involves evaluating equations which is both easy to specify, and at which computers are very good.

Once the screen-space coordinates of vertices are known, the polygons of the scene have to be *rasterized*, which consists in determining which pixels of the screen compose the projection of the polygon. This constitutes the denotation system of computer graphics, and each pixel in the image denotes a light ray from a point on the surface of the object to the image plane. Note that the continuous set of optical rays that go from the object to the viewpoint is sampled at a discrete grid of pixels.

Computer graphics then has to face an issue that has never really been a problem for human artists: visibility determination. That is, that some parts of a scene might be hidden or partly hidden by closer objects and have to be discarded in the final image. Willats (2002b) has suggested that humans have dealt with this problem in one or other of two ways. When drawing from life, and especially when drawing with the help of a device such as a *camera obscura*, hidden parts of the scene are simply omitted from the picture. This solution is not available, however, when pictures are drawn from memory or imagination. In this case, Willats suggests, hidden line elimination is not an operation that is carried out beforehand as it would be in a computer program, but takes place interactively during the course of

the drawing process. Once the drawing process begins the *pictorial image* (that is, the scene depicted within the picture) begins to emerge, and the representation of occlusion is carried out interactively by feedback between the mark-making process and the artist or draughtsman's perception of this pictorial image. In contrast, neither of these processes is currently available within a computer program, and complex procedures have had to be devised to characterize, compute and remove the hidden parts. The more qualitative nature of visibility makes it harder to characterize than the purely quantitative perspective. Visibility computation however usually does not lead to major style differences, since there is one 'correct' answer on which everybody agrees. A notable exception is the work by Renee Magritte *The Blank Check* (1965), where he inverts the rule of visibility to shock our visual system and install a surrealistic ambiance.

Once the scene primitives have been projected, rasterized into pixels, and visibility has been computed, the color attribute of each pixel needs to be determined. In photorealistic graphics, this involves modeling the interaction of light and objects. Two forms of lighting computation are distinguished: local and global. Local lighting, also known as shading, determines how the light that arrives at a point of an object is reflected towards the eye. It describes well-known effects, such as the fact that parts that face light are brighter than parts whose orientation is facing farther from the light, the basic principle of tonal modeling. On the other hand, global lighting studies light transport in the scene and longer-distance effects, such as cast-shadows, or the inter-reflection of light. Caravaggio was among the first painters to use dramatic global lighting effects, which contrasted to the local tonal modeling used by most Renaissance artists. More recently, the variety of color attribute systems has been widened with the development of the non-photorealistic lighting model known as 'toon shading'. These color models provide some tonal modeling but use a small number of different colors to imitate the look of cartoons, as demonstrated in Figure 6.

The mark system in traditional computer graphics is simple and direct; In contrast to styles such as Impressionism or pencil drawing, the marks in computer graphics are meant to be unnoticeable in order to put more emphasis on the pictorial image (that is, the depicted 3D scene) rather than on the 2D picture. The continuous 0-dimensional primitives sampled by pixels are usually displayed directly using Cathode-Ray Tubes or Liquid Crystal Displays, often using three different primary colors to implement a given pixel. In contrast,

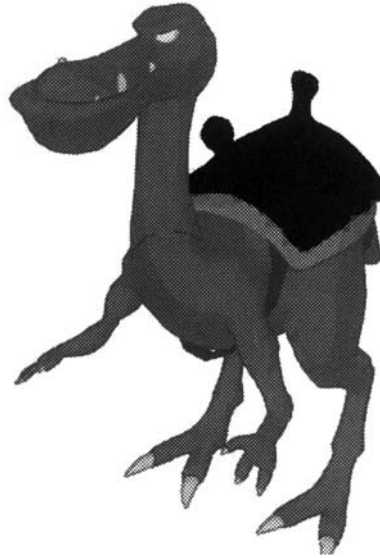

Figure 6. Non-Photorealistic shading. The color attributes provide some shape information through local shading, but does not look realistic. Note the second denotation system using lines, which are assigned the color of the object's material. Image courtesy of Stéphane Grabli.

traditional printing technology has lead to more involved mark systems, since the only mark available is usually a simple black dot. Halftoning techniques have been developed to lie out such tiny dots to give the impression of continuous grey or color levels, as can be seen on newspaper (Figure 7).

7.3 Procedural line drawing

We now discuss a new non-photorealistic rendering system that we developed for the automatic generation of line drawings from 3D models (Grabli et al., 2003). Our goal was to develop a flexible system that would allow us to explore the elusive notion of style, focusing on the line drawing denotation system. Our software takes as input a description of a three-dimensional scene similar to the traditional graphics pipeline discussed. The user of our system specifies style by writing explicit rules for transforming scene primitives into picture strokes. These rules can rely on a variety of properties of the input scene, as well as properties of the current drawing such as the local

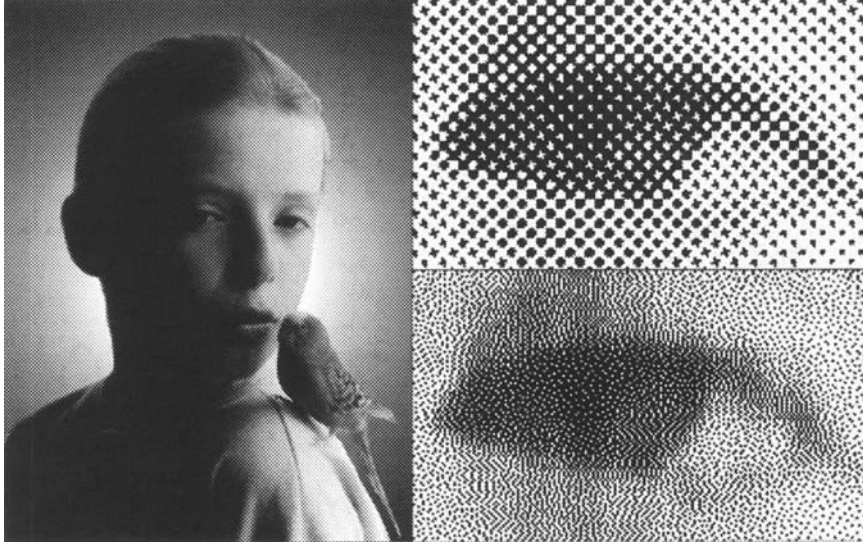
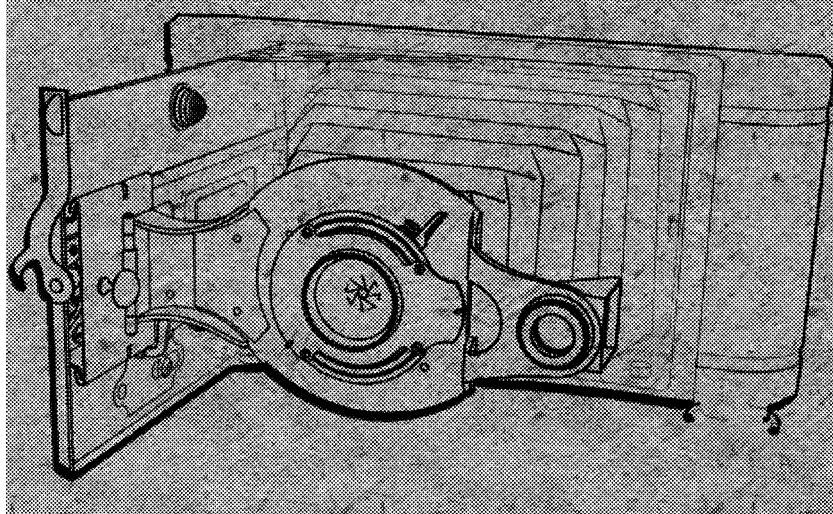

Figure 7. Two half-toning techniques. The upper-right image uses the clustered-dot dither technique. The lower-right image uses a variation of error-diffusion. Image courtesy of Victor Ostromoukhov.

density of strokes. In addition, semantic information such as the subjective importance of each object can be provided.

The drawing(spatial) system that we use is linear perspective, as in traditional graphics.

The denotation system yields the major stylistic difference with traditional computer imagery, since we use one-dimensional line primitive (line drawing denotation) instead of zero-dimensional pixels. We compute relevant 1D primitives from the input 3D model. We use lines to denote silhouettes (occluding contours), as well as sharp creases and object boundaries (like the boundary of a square). The extraction of the occluding contours is the most challenging task involved. Although their mathematical characterization is simple, developing a robust procedure to compute them is no easy task and has been the target of much effort in computer graphics. This phase of our system outputs a number of one-dimensional primitives and their adjacencies, characterized by T-vertices and end-junctions described above. The visibility of these lines also has to be evaluated. Line drawing is actually one of the rare denotation systems where visibility yields stylistic variations, since hidden lines are sometimes drawn with dashed lines.



```

Drawing[spatial]: Linear perspective
Denotation: Extract occluding contours
  Attribute: Assign black color
  Attribute: Vary thickness and tone with depth
Denotation: Extract external contour
  Attribute: Assign brown color
  Attribute: Vary thickness in a calligraphic way,
              with wider strokes on the lower-left
Mark: Ink

```

Figure 8. Line drawing generated by a computer from a 3D model and the informal description of its procedural style.

Selectively including or omitting certain lines can further refine the denotation system. Our system provides selection operators that allow the user to describe which lines should be included in the drawing based on properties such as visibility, length, curvature, objects they belong to, etc. We also allow strokes to be omitted when the local density of strokes in the current drawing becomes too high, which allows for less-cluttered drawings. This is a strong example of feedback, where the current state of the drawing influences subsequent depiction decisions. The development of richer selection strategies is an exciting challenge of our research.

The assignment of attributes is a central step of our approach. The user has complete freedom to determine the thickness, color, and transparency of strokes. The variation of these attributes can vary with any property of the scene. For example, in Figure 8, we varied the thickness and the tone based on the distance to the viewpoint. Thicker and darker strokes were used for close parts, which focuses

the attention on the front diaphragm and provides a sensation of depth. In addition, the user can vary the ‘wiggleness’ or smoothness of the strokes. More wiggly lines result in more sketchy styles (Figure 9).

The mark system takes the stroke primitives and their attributes computed in the previous steps, and implements them using the simulation of various media. In particular, the same stroke and attributes can be rendered with ink marks (Figures 8 and 9) or with charcoal (Figure 10). The mark system has been an active area of research in non-photorealistic rendering. A wealth of techniques have been devised to imitate traditional media, sometimes with elaborate physical simulation of paper–medium interactions. Our system uses simple techniques where physical strokes are scanned and used as textures by our mark implementation. The appropriate blending between multiple strokes that overlap results in the imitation of dry media such as graphite, or wet media such as ink.

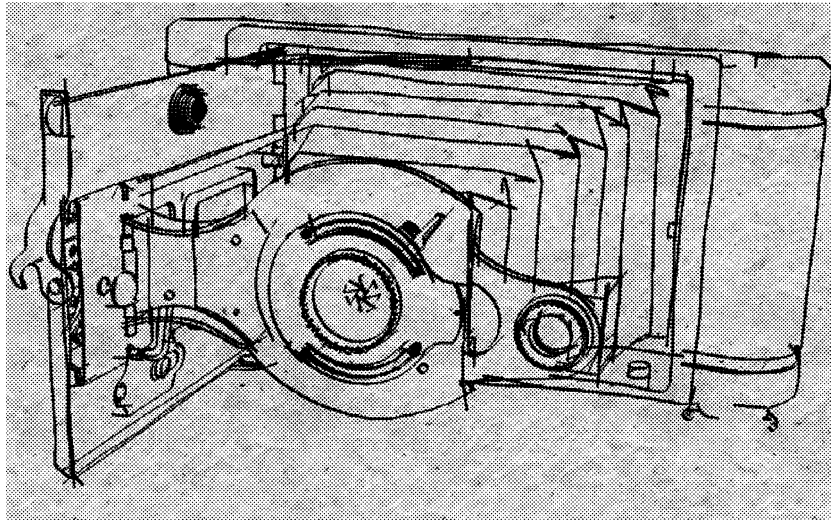

```
Drawing[spatial]: Linear perspective
Denotation: Extract occluding contours
  Attribute: Assign black color
  Attribute: Assign higher wiggleness
Mark: Ink
```

Figure 9. Line drawing generated by a computer from a 3D model and the informal description of its procedural style.

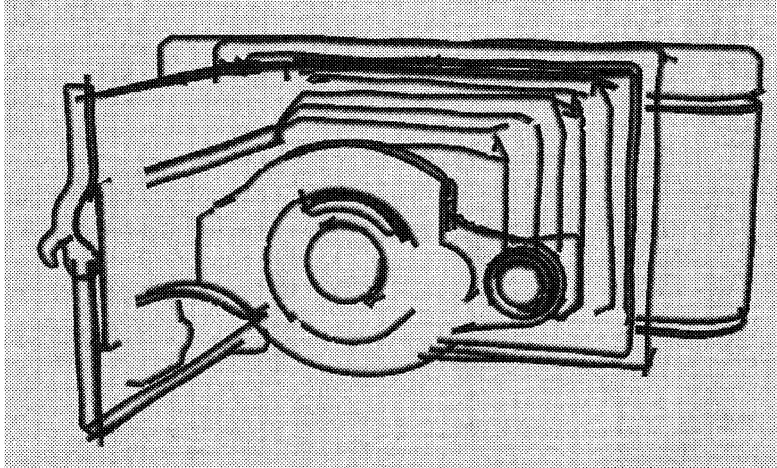

Drawing[spatial]: Linear perspective
 Denotation: Extract occluding contours, select only long contours
 Attribute: Assign grey color
 Attribute: Assign higher wiggleness
 Mark: Charcoal

Figure 10. Line drawing generated by a computer from a 3D model and the informal description of its procedural style.

In the examples given in Figures 8–10, the drawings are derived from a 3D model using ordinary linear perspective defined in terms of three-dimensional (primary) projective geometry, and here the emphasis is on the stylistic qualities of the denotation and mark systems used rather than the spatial systems.

In the following examples different aspects of style are explored. In the first, multiprojection rendering, complex drawing systems are used. In the second, Cohen's AARON, there is no input from 3D object space; instead AARON uses the rules of secondary geometry as the basis for the spatial system. In the third example, Burton's ROSE, the input takes the form of a 3D model but unlike the vast majority of computer graphics systems Rose never uses a viewpoint or a projection system. Instead, the spatial system is based on the use of topological properties such as touching and inclusion.

7.4 Artistic multiprojection rendering

While linear perspective and orthographic projections are by far the standard computer graphics drawing(spacial) systems, recent research

has proposed the use of more complex systems. Agrawala et al. (2000) developed computer graphics software allowing an artist to define different projections for the various objects in the scene. The user of this system can interactively specify the viewpoint and projection parameters independently for each object or group of objects in the scene. Figures 11 and 12 demonstrate the complex drawing systems that can be obtained.

This work was inspired by the observation that artist often vary the perspective or projection within the scene, either to improve the legibility of the picture, or to set a specific mood (Willats, 1997). In particular, the use of an anomalous drawing(spatial) system by De Chirico creates a dissonance and installs the melancholic mood of his painting (Figure 12).

7.5 Harold Cohen's AARON

The work of Harold Cohen is one of the first and most successful attempts at machine creativity (Cohen, 1979). Cohen, a painter himself, dedicated most of his life to developing a computer program named AARON that can produce compelling line drawing resembling the style of Cohen's own work. It is a unique example where an



Figure 11. Single vs. multiple projections. The left image is a classic linear perspective view. The right image uses multiple projections, and each object is assigned a different drawing(spatial) system. The background house is depicted using linear perspective to convey a sensation of depth, while the car and foreground character are represented using oblique projection to enhance the visibility of the character's face. Image courtesy of Maneesh Agrawala.

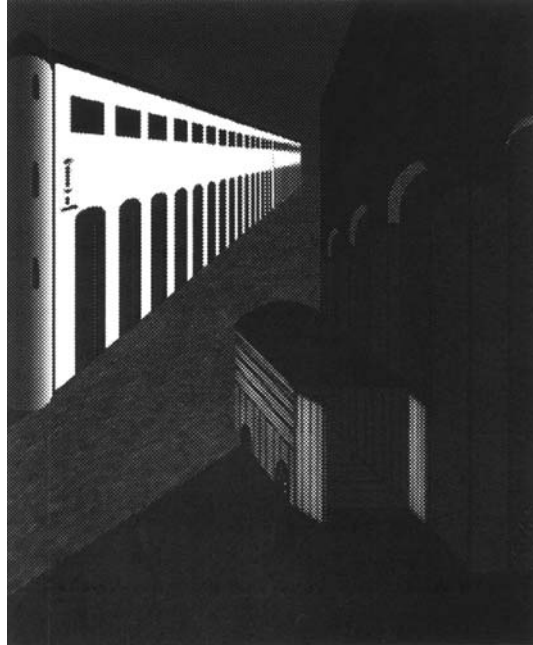

Figure 12. Computer reconstruction of De Chirico's *Mystery and Melancholy of a Street*. The multiple vanishing points result from the use of multiple projections. Image courtesy of Maneesh Agrawala.

artist has explicitly captured and encoded rules of depiction. In Cohen's words:

AARON is a knowledge-based program, in which knowledge of image-making is represented in rule form. As I have indicated I have been my own source of specialized knowledge, and I have served also as my own knowledge-engineer.

Cohen (1979), p. 1.

The use of randomness to influence decisions throughout the process makes each drawing produced by AARON unique and provides a fascinating impression of creativity (see Figure 13). As Cohen points out, AARON emphasizes the importance of the interpretation of the beholder in the picture transaction, for the program itself has access to no real visual data.

In contrast to the traditional computer graphics approaches we just discussed, AARON does not rely on a 3D object-space input but builds a figurative picture using purely 2D rules. It is therefore

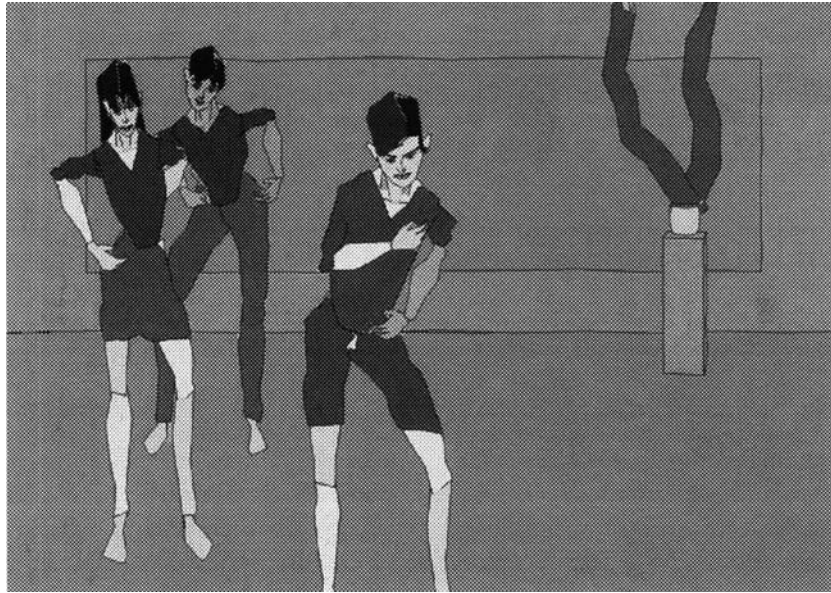

Figure 13. A freehand drawing created by Harold Cohen's AARON from KurzweilCyberArt.com.

not an information-processing approach, but rather a purely generative system. The 3D scene depicted by the drawing exists only in the gaze of the beholder. While most computer graphics approach work in *primary space*, which is the three-dimensional object space, AARON works in the *secondary space*, which is the two-dimensional picture (Willats, 1997; Durand, 2002). This challenges the view of depiction as a projection of a 3D scene and emphasizes the importance of rules in picture space and the *schema* described by Gombrich (1960/1988).

In its current version, AARON uses two denotation systems. The main system is line drawing, and a continuous zero-dimensional denotation is then used to colour the connected areas delimited by the lines (Cohen, 1999). In earlier versions, AARON used only line drawing, following generative rules that resulted in non-figurative blob-like drawings. The denotation primitive, the line, is the central object generated by AARON. A major part of the system is then dedicated to the spatial layout of these lines, which constitutes the drawing(spatial) system.

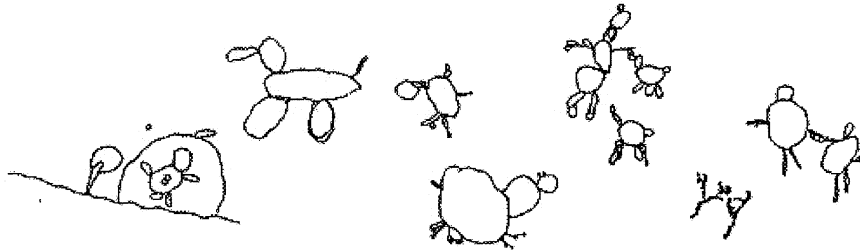

Figure 14. Drawings produced by ROSE in response to 3D models. Taken from Burton (1997), p. 304, Figure 3.

The mark system in AARON has taken different form. The same set of line primitives has been drawn using a plotter or a specialized turtle-like robot holding a pen, or rasterized onto a CRT monitor. Cohen has often painted on top of the computer output, which means that the computer was responsible of the line drawing denotation system, while the human applied the optical denotation and its attributes and marks.

7.6 *Burton's ROSE*

Burton (1997) described a program (ROSE) which produces drawings similar to those produced by young children. The rules embedded in this program are those of a denotation system mapping volumetric scene primitives into regions on the picture surface, similar to those that Willats (1985) suggested might underlie the drawings of 3- and 4-year-olds. As Figure 14 shows, the drawings produced by ROSE do resemble those produced by children at this age. As Burton pointed out, 'Since the computer is not analogous to the mind, ROSE does not simulate a child's activity and as such does not prove or disprove the theoretical models upon which it is based. However, successful implementation of a program demonstrates a theory's plausibility' (p. 302).

8. CONCLUSIONS

In this paper we have suggested a way of defining pictorial style in terms of combinations of four pictorial systems: devices or components that must be present in nearly all kinds of pictures. These are the drawing or spatial systems, the denotation systems, the mark systems, and the attributes systems. In the first part of the paper,

drawings by Poussin and Rembrandt, and a Greek vase painting were analyzed in terms of these pictorial systems in order to illustrate how this approach might be used to describe the pictorial styles of individual artists. In the second part, this approach was illustrated in a different way by showing how pictures in different styles might be generated by embodying these four pictorial systems in computer graphics programs.

Other ways of testing this approach might be used within computer graphics. For example, pictures might be derived from novel 3D models and assigned specific styles analogous to those used by artists such as Poussin or Rembrandt, as a way of testing the plausibility of definitions of style similar to those given above but embodied in a computer program. Alternatively, existing pictures might be reworked, reproducing the original depicted scene but changing the style, a process known as ‘transcription’. Producing transcriptions as a way of investigating style is a common practice among artists, as witness the many transcriptions of Manet’s *Le Déjeuner sur l’herbe*, 1863, and Rembrandt himself produced transcriptions of Persian miniature paintings. One of our long-term projects is to capture style from example pictures and re-apply it to different scenes.

ACKNOWLEDGEMENT

Many thanks to Stéphane Grabli, Emmanuel Turquin and Francois Sillion for their help on the procedural line drawing system, and to Sara Su for comments.

REFERENCES

- Agrawala, M., D. Zorin, and T. Munzner: 2000, ‘Artistic multiprojection rendering’, *Proceedings of the Eurographics Workshop on Rendering*, 2000.
- Baron-Cohen, S., R. Campbell, and A. Karmiloff-Smith et al.: 1995, ‘Are Children with Autism Blind to the Mentalistic Significance of Eyes?’, *British Journal of Developmental Psychology* **13**, 379–398.
- Burton, E.: 1997, ‘Artificial Innocence: Interactions Between the Study of Children’s Drawing and Artificial Intelligence’, *Leonardo* **30** (4), 301–309.
- Carter, B.A.R.: 1967, ‘The Use of Perspective in Saenredam’, *Burlington Magazine* **109**, 594–595.
- Chomsky, N.: 1957, *Syntactic Structures*, The Hague: Mouton.
- Chomsky, N.: 1965, *Aspects of the Theory of Syntax*, Cambridge, MA: MIT Press.
- Cohen, H.: 1979, *What is an Image?* http://www.kurzweilcyberart.com/aaron/hi_essays.html

- Cohen, H.: 1999, *Colouring Without Seeing: a Problem in Machine Creativity*, http://www.kurzweilcyberart.com/aaron/hi_essays.html
- Dubery, F. and J. Willats: 1972, *Drawing Systems*, London: Studio Vista; New York: Van Nostrand Reinhold.
- Durand, F.: 2002, 'An invitation to discuss computer depiction', *Proceedings of the Eurographics/SIGGRAPH Symposium on Non-Photorealistic Animation and Rendering*, June 2002.
- Gibson, J.J.: 1971, 'The Information Available in Pictures', *Leonardo* **4**, 27–35.
- Gombrich, E.H.: 1960/1988, *Art and Illusion: A Study in the Psychology of Pictorial Representation*, Oxford: Phaidon Press.
- Gooch and Gooch: 2001, *Non-Photorealistic Rendering*, A.K. Peters.
- Grabli, S., F. Durand, E. Turquin, and F. Sillion: 2003, A procedural approach to Style for NPR line drawing from 3D models. INRIA Technical Report, 2003.
- Hagen, M.A.: 1986, *Varieties of Realism: Geometries of Representational Art*, Cambridge: Cambridge University Press.
- Huffman, D.A.: 1971, 'Impossible Objects as Nonsense Sentences', in B. Meltzer and D. Mitchie (eds.), *Machine Intelligence*, vol. 6, Edinburgh: Edinburgh University Press, pp. 295–323.
- Kemp, M.: 1992, *The Science of Art: Optical Themes in Western Art from Brunelleschi to Seurat*. New Haven, CO.: Yale University Press.
- Kennedy, J.M.: 1974, *A Psychology of Picture Perception*, San Francisco: Jossey-Bass.
- Kennedy, J.M.: 1983, 'What Can we Learn about Pictures from the Blind?' *American Scientist*, **71**, 19–26.
- Koenderink, J.J. and A.J. van Doorn 1982, 'The Shape of Smooth Objects and the Way Contours End', *Perception* **11**, 129–137.
- Marr, D.: 1982, *Vision: A Computational Investigation into the Human Representation and Processing of Visual Information*, San Francisco: W.H. Freeman.
- Moskowitz, B.A.: 1978, 'The Acquisition of Language', *Scientific American* **239**, 82–96.
- Palmer, S.E.: 1999, *Vision Science: Photons to Phenomenology*, Cambridge, MA: MIT Press.
- Pearson, D., E. Hanna and K. Martinez 1990, 'Computer Generated Cartoons', in H. Barlow, C. Blakemore and M. Weston-Smith (eds.), *Images and Understanding* Cambridge: Cambridge University Press, pp. 46–60.
- Rawson, P.: 1987, *Drawing*, Philadelphia: University of Pennsylvania Press.
- Strothotte, T. and S. Schlechtweg: 2002, *Non-Photorealistic Computer Graphics. Modeling, Rendering, and Animation*, San Francisco: Morgan Kaufmann.
- Thouless, R.H.: 1933, 'A racial difference in perception', *Journal of Social Psychology* **4** (3), 330–339.
- Thorne, J.P.: 1972, 'Generative Grammar and Stylistic Analysis', in J. Lyons (ed.), *New Horizons in Linguistics*, Harmondsworth, Middlesex: Penguin, pp. 185–197.
- Waltz, D.: 1975, 'Understanding Line Drawings of Scenes with shadows', in P.H. Winston (ed.), *The Psychology of Computer Vision*, New York: McGraw-Hill, pp. 19–91.
- White, J.: 1967, *The Birth and Rebirth of Pictorial Space*, London: Faber and Faber.
- Willats, J.: 1985, 'Drawing Systems Revisited: The Role of Denotation Systems in Children's Figure Drawings', in N.H. Freeman and M.V. Cox (eds.), *Visual Order: The Nature and Development of Pictorial Representation*, Cambridge: Cambridge University Press, pp. 78–100.

- Willats, J.: 1992a, 'Seeing Lumps, Sticks and Slabs in Silhouettes'. *Perception* **21**, 481–496.
- Willats, J.: 1992b, 'The Representation of Extendedness in Children's Drawings of Sticks and Discs', *Child Development* **63**, 692–710.
- Willats, J.: 1997, *Art and Representations: New Principles in the Analysis of Pictures*, Princeton: Princeton University Press.
- Willats, J.: 2002a, 'The Rules of Representation', in P. Smith and C. Wilde (eds.), *A Companion to Art Theory*, Oxford: Blackwell, pp. 411–425.
- Willats, J.: 2002b, 'The Third Domain: The Role of Pictorial Images in Picture Perception and Production', *Axiomathes* **13** (1), 1–15.
- Willats, J. (in press), 'Optical Laws or Symbolic Rules: The Dual Nature of Pictorial Systems', In H. Hecht, B. Schwartz and M. Atherton (eds.), *Reconceiving Pictorial Space*. Cambridge, MA: MIT Press.
- Wölfflin, H.: 1932, *Principles of Art History*, London: G. Bell & Sons.
- Wollheim, R.: 1977, 'Representation: The Philosophical Contribution to Psychology', in G. Butterworth (ed.), *The Child's Representation of the World*, New York: Plenum Press, pp.173–188.
- Wollheim, R.: 1987, *Painting as an Art*, London: Thames and Hudson.