Transfer function-noise modeling and spatial interpolation to evaluate the risk of extreme (shallow) water-table levels in the Brazilian Cerrados

Rodrigo L. Manzione · Martin Knotters ·
Gerard B. M. Heuvelink · Jos R. Von Asmuth ·
Gilberto Camara

Abstract Water regimes in the Brazilian Cerrados are sensitive to climatological disturbances and human intervention. The risk that critical water-table levels are exceeded over long periods of time can be estimated by applying stochastic methods in modeling the dynamic relationship between water levels and driving forces such as precipitation and evapotranspiration. In this study, a transfer function-noise model, the so called PIRFICT-model, is applied to estimate the dynamic relationship between water-table depth and precipitation surplus/deficit in a watershed with a groundwater monitoring scheme in the Brazilian Cerrados. Critical limits were defined for a period in the Cerrados agricultural calendar, the end of the

rainy season, when extremely shallow levels (<0.5-m depth) can pose a risk to plant health and machinery before harvesting. By simulating time-series models, the risk of exceeding critical thresholds during a continuous period of time (e.g. 10 days) is described by probability levels. These simulated probabilities were interpolated spatially using universal kriging, incorporating information related to the drainage basin from a digital elevation model. The resulting map reduced model uncertainty. Three areas were defined as presenting potential risk at the end of the rainy season. These areas deserve attention with respect to water-management and land-use planning.

Keywords Agriculture · Statistical modeling · Geostatistics · Groundwater management · Brazil

Received: 19 January 2010 / Accepted: 10 September 2010
Published online: 30 September 2010

© Springer-Verlag 2010

R. L. Manzione (✉)
UNESP (Universidade Estadual Paulista),
Campus de Ourinhos. Av. Vitalina Marcusso, 1500,
CEP: 19910-206, Ourinhos, SP, Brazil
e-mail: rlmansione@gmail.com
Tel.: +55-14-330-25716

M. Knotters · G. B. M. Heuvelink
Alterra – Soil Science Centre,
Droevendaalsesteeg 4, 6708PB, Wageningen, The Netherlands

M. Knotters
e-mail: Martin.Knotters@wur.nl

G. Heuvelink
e-mail: Gerard.Heuvelink@wur.nl

J. R. Von Asmuth
Delft University of Technology,
Water Resources Section P. O. Box 5048 2600 GA Delft,
The Netherlands
e-mail: jos.von.asmuth@gmail.com

G. Camara
INPE (National Institute for Spatial Research),
DPI (Image Processing Division). Av. dos Astronautas, 1758
Caixa Postal 515 CEP: 12227-010, São José dos Campos, SP, Brazil
e-mail: gilberto.camara@inpe.br

Introduction

To support effective water management, it is necessary to monitor water resources, to model hydrological processes, and to simulate the effects of policy measures. Researchers are challenged to develop methods and tools to monitor and describe the spatio-temporal dynamics of the hydrological system. Risk management of water resources requires the use of stochastic modeling techniques that account for uncertainty. It is possible to predict the future state in terms of probability. According to Hipel and McLeod (1994), the starting point is that future values have a probability distribution which is conditioned by knowledge of past values. The future state of a stochastic process is characterized by a set of realizations, which can be regarded as the outcomes of a probability experiment. The parameters of hydrological systems can vary greatly in time and space, but they are usually sparsely sampled. Knowledge of system dynamics is therefore partial at best, and the most one can usually do is quantify the uncertainty through stochastic modeling (Winter 2004), expressed in terms of risk. The output of these models that take uncertainty into account can next be used in statistical decision making.

The Brazilian Cerrados are currently Brazil's biggest grain belt. Human activities have changed the region during the past 40 years, and exploited its natural resources (Klink and Moreira 2002). The region is characterized by a well-pronounced dry season, from May until September. During this period, the growth of natural vegetation and agricultural crops depends on groundwater. The Cerrados natural vegetation is adapted to the local climate, but the cash crops cultivated in the region are not. Irrigation techniques are used to keep productivities high during the whole year. Groundwater and surface-water availability make this possible. Monitoring schemes of wells in a watershed provide information on the spatio-temporal dynamics of the water table. Nowadays, with almost all Cerrados natural vegetation replaced by agricultural crops, knowledge about the spatio-temporal dynamics of the water table is important to optimize and balance economic and ecological interests (Von Asmuth and Knotters 2004). Intensive use of groundwater may cause a lowering of water tables, with many negative effects. These changes can affect not only the water balance and the original ecosystem, but also endanger the economic activities and the population settled in the basin that depends on groundwater supply. Manzione et al. (2008) investigated the effects of this water abstraction at the end of the dry season (beginning of October) in the Brazilian Cerrados to see if the agricultural crops starting to be cultivated at this time are affected by extremely low groundwater levels or even dry wells. Monitoring strategies should be part of the land-use and water-use planning to avoid water losses that would affect agricultural activities.

Water-table dynamics can be modeled in several ways, varying from complex physical-mechanistic models to simple empirical time-series models. Stochastic approaches using relatively simple transfer function-noise models (Box and Jenkins 1976; Hipel and McLeod 1994) have been successfully applied to describe the dynamic relationship between precipitation surplus and water-table depth in several studies (e.g. Tankersley and Graham 1994; Van Geer and Zuur 1997; Knotters and Van Walsum 1997; Yi and Lee 2003; Von Asmuth and Knotters 2004). The main advantage of stochastic techniques, from a practical point of view, is their ability to quantify the uncertainty inherent in any underground study (Winter 2004). This allows evaluation of risks resulting from heterogeneity and lack of information on design and management (Renard 2007).

Transfer function-noise models can be calibrated to a set of time series observed in various wells in an area. Next, the time-series model parameters or the model predictions can be interpolated spatially, using ancillary information related to the physical basis of these models (Knotters and Bierkens 2000, 2001). In this approach, the spatial differences in water-table dynamics are determined by the spatial variation in the system properties, while its temporal variation is driven by the dynamics of the input into the system. The PIRFICT-model (predefined impulse response function in continuous time) is an alternative to

discrete-time transfer function-noise (TFN) models (Von Asmuth et al. 2002). An important advantage in the use of the PIRFICT-model, compared with discrete-time TFN models, is that it can deal with input and output series which have different observation frequencies and irregular time intervals (Von Asmuth and Bierkens 2005). Time series of the groundwater level, often collected manually, tend to be non-equidistant and contain missing data (Von Asmuth et al. 2002). The PIRFICT-model can be calibrated on data at any frequency available because it operates in a continuous time domain and the time steps of the output variable are not coupled to the time steps of the input variables.

This work presents a combination of time-series modeling and spatial analysis applied to a monitoring database of water heads and climate information, to map risks of extremely *shallow* water-table levels for a specific critical period in time and space. The study focuses on a watershed with a groundwater monitoring scheme installed in the Brazilian Cerrados, aiming to provide information about water-table-depth dynamics and shallow levels, which influence agricultural activities at the end of the rainy season. Simulating model results, the study could account for model uncertainty—valuable information for sustainable water management and land use planning, visualized as risk maps.

Materials and methods

Study area

The Brazilian Cerrados extend from the northern margins of the Amazonian evergreen forests to isolated spots on the southern borders of the country with extensions into Paraguay and Bolivia. Placed in the central plateau, it covers 22% of the Brazilian territory or around 2 million km² (Jepson 2005). The region is the most extensive woodland-savannah in South America.

The Jardim River micro basin is situated in the eastern part of the Brazilian Federal District (DF), between latitudes 15°40'S and 16°20'S and longitudes 47°20'W and 47°40'W (Fig. 1). This basin is a representative Cerrado area and is part of one of the most important basins of Brazil: the São Francisco Basin. The total drainage area of this basin is 101.21 km². Agricultural crops have replaced almost all natural vegetation of the Jardim River basin. The natural vegetation varies from gallery forests forming corridors close to the river course, to some spots of woody savannah (*Cerrado*), open woody savannah (*campo Cerrado*), scrubby savannah (*campo sujo*), and open grassland (*campo limpo*; Furley 1999). The main cultivation crops in the area are grain (soybeans, corn, wheat and beans), coffee, cotton, fruits, and horticulture products, as well as cattle, dairy farming and poultry. The dry and wet seasons are well defined, with the rainfall concentrated between October and April. The annual mean precipitation was 1,386 mm from 1974 to 2007. The daily average temperatures vary from 18 to 30°C during the year. The main rivers in the basin are

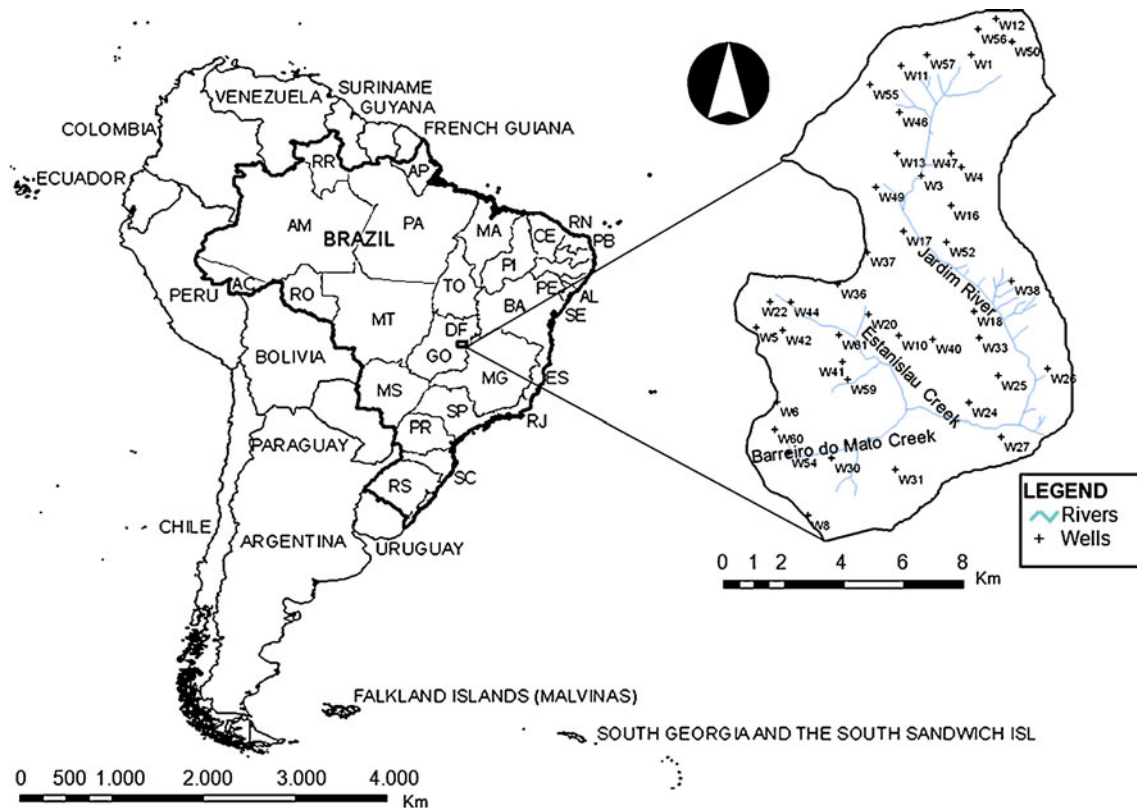

Fig. 1 Map of the Brazilian territory (delineating Brazilian states) and the Jardim River watershed and well locations

the Jardim River, Estanislau Creek and Barreiro do Mato Creek. The water flows from natural springs. The landforms are mostly flat (slopes varying from 0 to 3%) or gently sloping (slopes between 3 and 8%), representing 53.33 and 43.05% of the basin area, respectively (Embrapa 1999). The maximum elevation is 1,176 m and the minimum 890 m, above sea level. A digital elevation model with 15-m horizontal resolution provides ancillary information related to local geomorphology.

Hydrogeological features

The hydrogeology of the study area is characterized by two main aquifer reservoir systems: fractured and porous domains (Campos 2004). The porous domain is characterized by a geological upper layer in which the water is stored in the empty spaces of the rocky bodies (saprolite). The pore spaces in the upper layer are secondary formation, created by weathering of the bedrock. This layer overlies the metasedimentary rocks of the Canastra, Bambuí and Paranoá groups, which correspond to the fractured aquifers in the area. In the fractured domain, the water flow and storage take place in the physical discontinuities in the rocks, forming a system of secondary porosity.

The fractured domain comprises four systems: Paranoá (subsystems R3/Q3 and R4), Canastra (subsystem F) and Bambuí (Fig. 2a). Fractures, cracks and faults in the rocks are reservoirs for water, varying from a few meters to hundreds of meters. The aquifers can be unconfined or

confined, highly anisotropic and heterogeneous. These rocks form the deep groundwater system in the area. The recharge of these aquifers is from vertical and lateral flow of precipitation-water infiltration. The geomorphology of the region highly influences the main areas of regional recharge. The differences in the rock types of these systems lead to different hydrodynamic parameters. Subsystem R3/Q3 consists of a sandy/quartzite layer that favors open cracks, resulting in water flows around 12,200 L/h. This flow is higher than the other fractured systems and subsystems, being the major source of natural discharge in the northern part of the basin. R4, F and Bambuí consist of clay layers, resulting in a water flow around 6,100, 7,500 and 5,200 L/h, respectively (Souza and Campos 2001). The porous domain is a non-consolidated geological environment with predominant thickness varying between 15 and 25 m (>60%), large extension and is, in general, homogeneous. These aquifers form the shallow groundwater system. The porous domain comprises three systems: P1, P2 and P4 (Fig. 2b). The water flux at these aquifers is small compared with the deep groundwater system of the fractured domain (Souza and Campos 2001). They differ in thickness and granulometry. P1 has moderate thickness (around 10 m) and sandy texture. P2 has large thickness (more than 10 m) and sandy to loamy texture. P4 has small thickness (less than 10 m) and rocky texture. Reatto et al. (2000) presented a large-scale soil survey of Jardim River watershed at scale 1:50,000 (Fig. 2c). The soil classes identified in the basin are red latosol (LV), red yellow

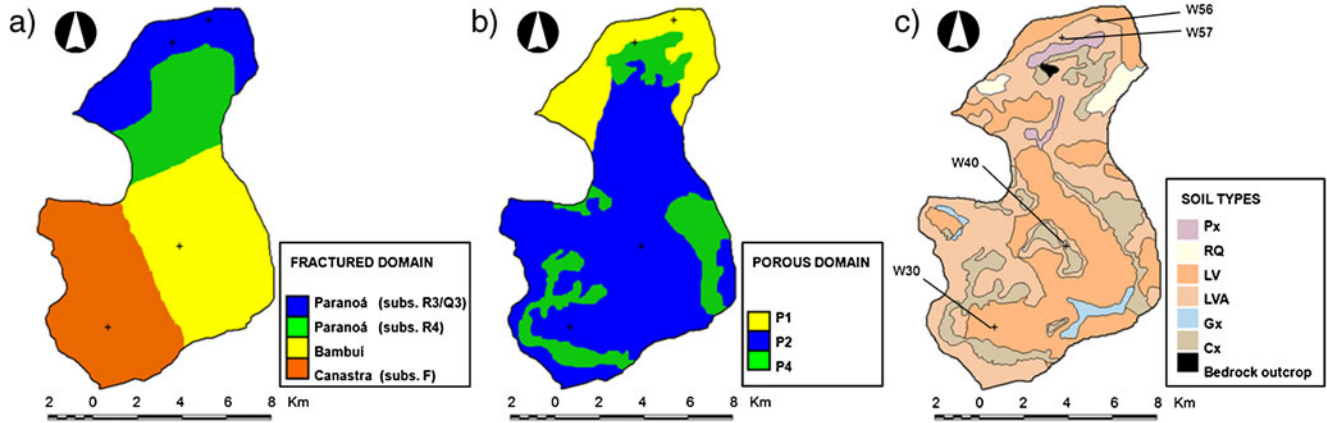

Fig. 2 a Fracture and b porous hydrological domains, and c soil types in the Jardim River watershed. Legend for c: (LV) red latosol, (LVA) red yellow latosol, (Cx) haplic cambisol, (Px) haplic plinthosol, (Gx) haplic gleysol, and (RQ) quartzarenic neosol

latosol (LVA), haplic cambisol (Cx), haplic plinthosol (Px), haplic gleysol (Gx) and quartzarenic neosol (RQ).

Monitoring water-table depths and climatological parameters

Water-table depths were observed with a semi-monthly frequency from 11 October 2003 until 06 March 2007, at 40 wells (Fig. 1). These wells were selected to cover the range of soil types and hydrogeological domains in the area, in an attempt to characterize the different responses of water-table depths in the basin. The length of the time-series data of water-table depths was 1,240 days. The screen depth in the wells varied with soil depth. A data series of 33 years for precipitation and potential evapotranspiration was available from a climate station close to the basin (Taquara Station). These data were available monthly from 1974 to 1996, and then daily from 1996 to the present.

Time-series modeling with the PIRFICT-model

The PIRFICT-model was implemented using the computer package Menyanthes (Von Asmuth et al. 2010). Here, there is just a brief description of the model formulation. In the next section, an innovation in the method is presented, regarding simulation of the random component of the model to predict extreme water-table levels in time and to map them in space. For a detailed description of the PIRFICT-model, Von Asmuth et al. (2002) present a single input/output time-series approach, and Von Asmuth et al. (2008) introduced a more complex approach using a multiple-input stress series.

In the PIRFICT-model, a block pulse of the input is transformed to an output series by a continuous-time transfer function. The outputs are a predicted series of water-table depth, $h_i^*(t)$, at time t , credited to stress i , with coefficients that do not depend on the observation frequency. There are many types of stresses that can affect the water-table depth. Von Asmuth et al. (2008) distinguished several stresses, including precipitation, evapotranspiration, groundwater withdraw (or injection),

surface-water levels, barometric pressure and hydrological interventions. Here in this study, $h_i^*(t)$ is credited to the precipitation and evapotranspiration stresses, modeled as transfer function-noise by the PIRFICT-model (Fig. 3). In general, groundwater systems react differently to the different stresses to which they are submitted. However, there are also cases where different stresses, like precipitation and evapotranspiration, cause similar responses. The effect of evapotranspiration on the water-table depth is the same as precipitation, but negative, discounting its influence from precipitation, similar to a water balance.

The impulse response (IR) function describes the way the water table responds to an impulse of precipitation. The form and area of the impulse response function depends strongly on the local hydrological circumstances. The IR function is typically taken as a Pearson type III distribution function (PIII df; Abramowitz and Stegun 1964), which can model the response of a broad range of groundwater systems. It is adjusted from the response of the water table given from exogenous inputs. The physical basis of the PIII df lies in the fact that it describes the transfer function of a series of linear reservoirs (Nash 1958). Compared to the combined autoregressive (AR) model and Kalman filter, the PIRFICT-model offers a further extension of the possibilities of calibrating transfer function-noise models on irregularly spaced

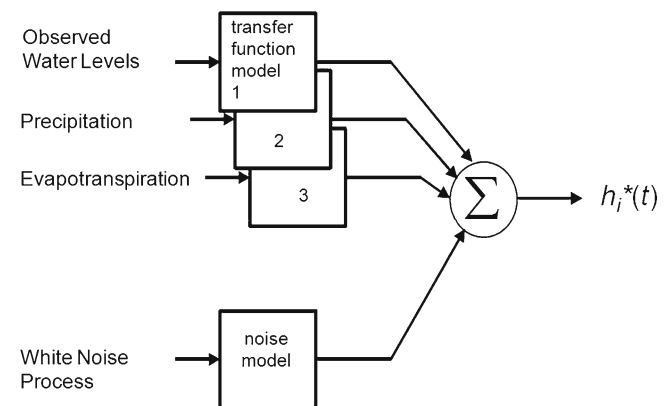

Fig. 3 Schematic representation of the transfer functions implemented in the PIRFICT-model

time series, because the shape of the transfer function is not restricted to an exponential function (Von Asmuth and Bierkens 2005).

In the continuous case, the model order is defined by choosing continuous mathematical functions to represent the IR functions. Von Asmuth et al. (2002) presented several important differences from the discrete-model identification procedure. First of all, a continuous IR function can have a flexible shape and be equivalent to a series of autoregressive/moving average (ARMA) transfer functions. Secondly, the model identification procedure is simplified, because the model frequency does not interfere with the model order and parameter values, and the flexibility of a single continuous IR function can be such that it comprises a range of ARMA transfer functions. Thirdly, the model can be readily identified using physical insight. A continuous IR function can be objectively chosen as the function that best represents the physics of the analyzed system. A physically based IR function on the one hand reduces the sensitivity of the model to coincidental correlations in the data, but on the other hand it can reduce the fit if for some reason the physical assumptions prove to be incorrect (Von Asmuth et al. 2002).

Mapping risks of extreme water-table levels

Models describing the relationship between precipitation surplus/deficit and water-table depth using time series that have a limited number of years of water-table data, can be used to simulate new series of extensive length using input series on precipitation surplus/deficit of extensive length (for example 30 years). The assessment of risk demands an understanding of extreme events, which are far from average by definition (Winter 2004). Statistics of the temporal variation of water-table depths can be calculated from simulated series. These statistics will represent the prevailing hydrological and climatic conditions rather than specific meteorological circumstances during the monitoring period of water-table depths (Knotters and Van Walsum 1997). In this study, the focus is on statistics of extremes, more specifically probabilities that critical levels are exceeded.

The series of precipitation and potential evapotranspiration with 30 years length were transformed into series of water-table depths, by using the PIRFICT-model calibrated on the observed series of 1,240 days (from 11 October 2003 until 6 March 2007). In this way, one obtains a series of deterministic predictions of water-table depths, with a length of 30 years. Then, N realizations of the noise process are generated by stochastic simulation. Let l be the number of semi-monthly time steps in the period, and let m be the number of semi-monthly time steps in the monitoring period. Realizations of the random process $r(t)$, $t=1, 2, \dots, l$, are generated, reconstructing the residual series $r(t)$, $t=1, 2, \dots, m$, based on a time frequency filtering of the PIRFICT-model. It is performed as a convolution in the time frequency domain, considering the shape of the PIII df adjusted from the parameters

of each model. The operation in the time-frequency domain is the time frequency expansion of the precipitation input signal and the time-frequency response of the aquifer system. These simulated residual series are added to deterministic series resulting in N realizations of the series of water-table depths. In this study, a random sampling is applied in the normal distribution of the noise process, with zero mean and residual variance.

From a large number of realizations ($N=1,000$), probability density functions (PDFs) of water-table depths were calculated for the end of the wet season. This is an important period in the Cerrados agricultural calendar because it is when the water table reaches the highest level and there are risks associated with shallow groundwater levels. The 30th of April is considered as a hypothetical date for this scenario. Around this period the cultivation ends and harvest operations start. The 95th percentile from the PDFs was selected as the shallow-risk threshold. The limit defined for risks of shallow water-table levels was 0.5 m below the ground surface. The risk is estimated as the probability of exceeding a critical level, plus the exposure to this critical level during a continuous period of time, for instance 10 continuous days.

Many hybrid interpolation techniques, which combine kriging and use of auxiliary information, have been developed, tested and are available to improve the accuracy of spatial predictions. A geostatistical spatial prediction technique, which jointly employs correlation with auxiliary variables and spatial correlation, is universal kriging (UK), originally described by Matheron (1969). Other variants of UK are kriging with external drift (KED) and regression kriging (RK). In fact, UK, KED and RK are equivalent methods and should, under the same assumptions, yield the same predictions (Hengl et al. 2004). Some authors (Deutsch and Journel 1992; Wackernagel 2003) consider that the term UK should be reserved for the case where the drift (or trend) is modeled as a function of the coordinates only. Here, however, a more general interpretation is taken, in which UK refers to kriging in the presence of a trend that is a linear combination of known auxiliary variables (Christensen 1991; Cressie 1993).

The 95th percentile values of the PDFs for all wells for 30 April were interpolated spatially using universal kriging. The resulting maps present the water-table depths that will be exceeded with 5% chance. This interval was considered to be reasonable for the accuracy of the database. The digital elevation model was used as ancillary information in the universal kriging system. The use of elevation as a covariate can improve the spatial prediction, enhance the physical meaning of the predictions and yield more plausible spatial patterns. Elevation is physically related to water-table depth, since it is related to the local geomorphology. Areas with relatively low elevation and that are close to drainage systems present shallow water tables, whereas in areas with relatively high elevation, far from drainage devices, the water table is deep (Furley 1999).

The UK model splits the random function into a linear combination of deterministic functions, known at any point of the region, and a random component, the residual random function. For the whole domain there are functions of the two-dimensional coordinates x , which are considered deterministic, because these are known at any location of the domain (Wackernagel 2003). The digital elevation model was incorporated as a drift in the spatial prediction model. Let the probability of exceedence of a critical level be given as $z(x_1), z(x_2), \dots, z(x_n)$, where x_i is a well location and n is the number of observations. At a new, unvisited location x_0 in the area, $z(x_0)$ was predicted by summing the predicted drift and the interpolated residual (Odeh et al. 1994; Hengl et al. 2004):

$$\hat{z}(x_0) = \hat{m}(x_0) + \hat{e}(x_0) \quad (1)$$

where the drift m is fitted by linear regression analysis, and the residuals e are interpolated using kriging:

$$\hat{z}(x_0) = \sum_{k=0}^p \hat{\beta}_k \cdot q_k(x_0) + \sum_{i=1}^n w_i(x_0) \cdot e(x_i); q_0(x_0) = 1 \quad (2)$$

Here, the β_k are estimated drift model coefficients, $q_k(x_0)$ is the k th external explanatory variable (predictor) at location x_0 , p is the number of predictors, $w_i(x_0)$ are the kriging weights and $e(x_i)$ are the zero-mean regression residuals.

The kriging system is solved for each grid node as a function based on the relationship of ground surface elevation and estimated water levels depths as follows:

$$\hat{h}(x_0) = \beta_0 + \beta_1 \cdot E(x_0) + e(x_0) \quad (3)$$

where E is the elevation value for each location and e is a zero-mean spatially correlated residual. Its spatial correlation structure is characterized by a semivariogram. The semivariogram is the spatial estimator of dependence between observation points and provides information to the kriging system perform spatial interpolation. The results of spatial interpolation were evaluated using cross-validation (Wackernagel 2003; Pebesma 2004).

Results and discussion

Calibration of the time-series models

Figure 4 shows observed and modeled water-table depth for four wells representing different soil types, hydrogeological systems and land uses. Well 30 (W30) is located in the western part of the basin, under the fractured hydrogeological subsystem F, porous hydrogeological system P2, red latosol and pasture. Well 40 (W40) is located in the central part of the basin, under fractured hydrogeological subsystem Bambuí, porous hydrogeological system P2, cambisol and pasture. Well 56 (W56) is located in the extreme northern part of the

basin, under fractured hydrogeological subsystem R3/Q3, porous hydrogeological system P1, red yellow latosol and agriculture. Finally, well 57 (W57) is located in the northern part of the basin, under fractured hydrogeological subsystem R3/Q3, porous hydrogeological system P4, red yellow latosol and Cerrado vegetation. Figure 2 gives the location of these wells under each geological layer and soil type. All well screens are located in the porous layers of each domain. Figure 4 indicates that the water levels respond differently to the same inputs, depending on the hydrogeologic conditions.

The different hydrological conditions in the basin also give a wide range of calibration results for all 40 wells analyzed (summarized in Table 1). The goodness of fitness is indicated by three parameters: the percentage of variance accounted for (R^2_{adj}), the root mean squared error (RMSE) and the root mean squared innovation (RMSI). The given values of R^2_{adj} indicate a good fit of the PIRFICT-model to the data. The RMSE is a measure of the overall error of the transfer model. The RMSI is the average innovation or error of the combined transfer and noise model (Wiener process).

Errors in data or even lack of data might affect model accuracy. The R^2_{adj} gives information from the residual variance weighted according to the variance of the original series signal (Von Asmuth et al. 2008). In this case, all calibrations present good results, with errors varying from centimeters (13 cm) to a few meters (1.37 m), which is perfectly acceptable, considering the depth of the wells and the thickness of the vadose zone.

The diagnostic check of the IR functions also showed the different responses of water-table depths in the Jardim River watershed. Figure 5 gives the impulse response functions for precipitation input for the wells W30, W40, W56 and W57. The functions have higher response factors for wells with large water-table-depth amplitudes (W30 and W40). It can be seen that the response time is amply covered by the monitoring period of 1,240 days.

Interpretation of model results

The differences seen in the variation of water-table depths for the selected wells can be explained from the hydrogeological patterns in the Jardim River watershed. For example, W30 and W40 have larger amplitude between maximum and minimum water-table depths than W56 and W57 (Fig. 4). This can be explained by the hydrogeological subsystem P2 which consists of deep layers associated with pelitic rocks. This material is highly susceptible to chemical weathering and it favors decomposition of the underlying rock, causing a thick pedologic covering. The resulting soils are red latosols, sandy to loamy, with moderate porosity. The saturated thickness of this system is more than 10 m and the residence time of groundwater in the aquifer system is long since they are big water reservoirs. System P2 comprises the major part of the basin. Water level in well W30 is deeper because it is located under

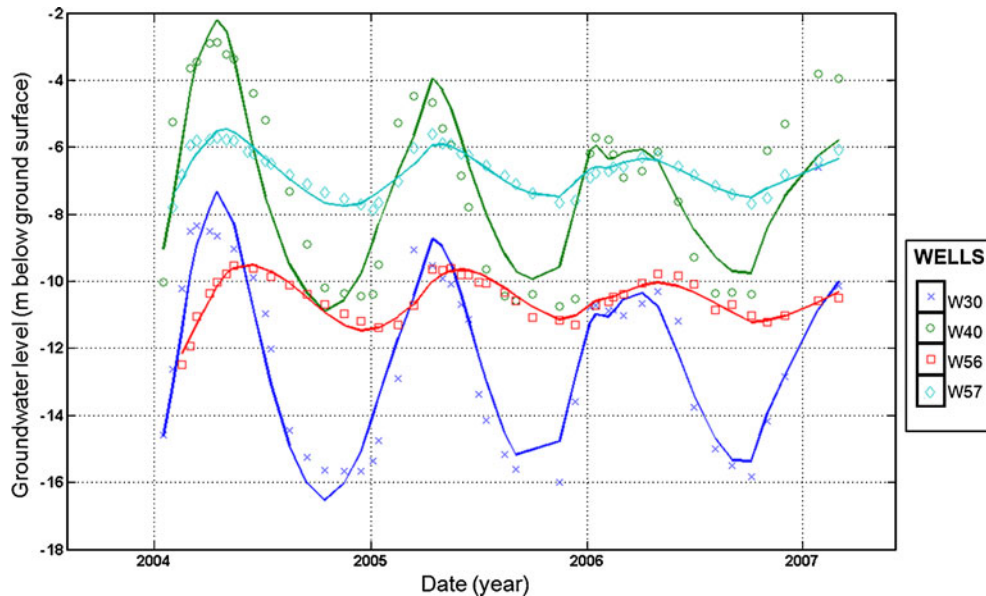

Fig. 4 Examples of PIRFICT-model calibrations on water-table depth time series at four wells in the Jardim River watershed (*Shapes*: observations, *lines*: modeling results)

more developed red latosols (Reatto et al. 2000). Wells W56 and W57 present faster responses. The water flux is intense in the northern part of the basin due to the local hydrogeology, contributing also to natural discharge (Campos and Tröger 2000). W56 is located in system P1, which is developed from sandy metarhytmities and medium quartzites from the Paranoá group, resulting in red yellow latosols. The thickness of the saturated zone in this system is around 10 m (Souza and Campos 2001). At W57, the levels are more superficial due to the rocky nature of the local geology of system P4, and the responses are even faster to precipitation surplus inputs (Fig. 5). System P4 is associated with pelitic rocks (schists and phylites) which produced shallow and rocky soils close to drainage systems and the river springs. The saturated thickness of this system is less than 10 m. These wells present just a few examples of how differently the water-table depths can react in a small catchment like the Jardim River watershed. The flexibility of Pearson III df makes it possible to adjust the PIRFICT-model closely to these different responses.

Simulation with the PIRFICT-model and mapping of water-table depth

The spatial structure of the expected values of water-table depth that will be exceeded with 5% probability

was modeled by semivariograms and interpolated using ancillary information. The spatial dependence at short distances is poorly estimated because of the small number of observation wells, which are fairly uniformly distributed in the area (Goovaerts 1997; Chilès and Delfiner 1999). For 30 April, there is risk of shallow water tables exceeding the level of 0.5 m below ground surface and this is fixed as critical. Figure 6 gives the map of water-table depths that will be exceeded with 5% chance on 30 April, interpolated using universal kriging using the digital elevation model of the basin as ancillary information.

Including elevation as a spatial drift into the geostatistical model caused a decrease in the semivariance (Table 2). The results of spatial interpolation were evaluated by cross-validation. The mean interpolation errors are small (-0.01 m). The mean and standard deviation of the Z-score had values close to zero and one, respectively. These results suggest a good performance of the kriging system and the estimations. The use of the digital elevation model as ancillary information improved the quality of the maps of water-table depth and provided a physical interpretation of the maps, related to the drainage patterns.

The water-table variation in the basin is dependent on the geological/pedological layer occurrence. The simulated levels for 30 April (Fig. 6) were deeper in the northern and

Table 1 Summary of the statistics of PIRFICT-model calibrations for all 40 wells.

	Min	1st Q	Med	3rd Q	Max	Mean	SD
R^2_{adj}	69.3	75.5	79.9	85.1	94.0	80.0	6.56
RMSE	0.13	0.32	0.66	0.90	1.37	0.65	0.35
RMSI	0.13	0.26	0.50	0.73	1.27	0.52	0.29

R^2_{adj} percentage of explained variance; *RMSE* root mean squared error (m); *RMSI* root mean squared innovation (m); *Min* minimum; *1st Q* first quartile; *Med* median; *3rd Q* third quartile; *Max* maximum; *SD* mean standard deviation

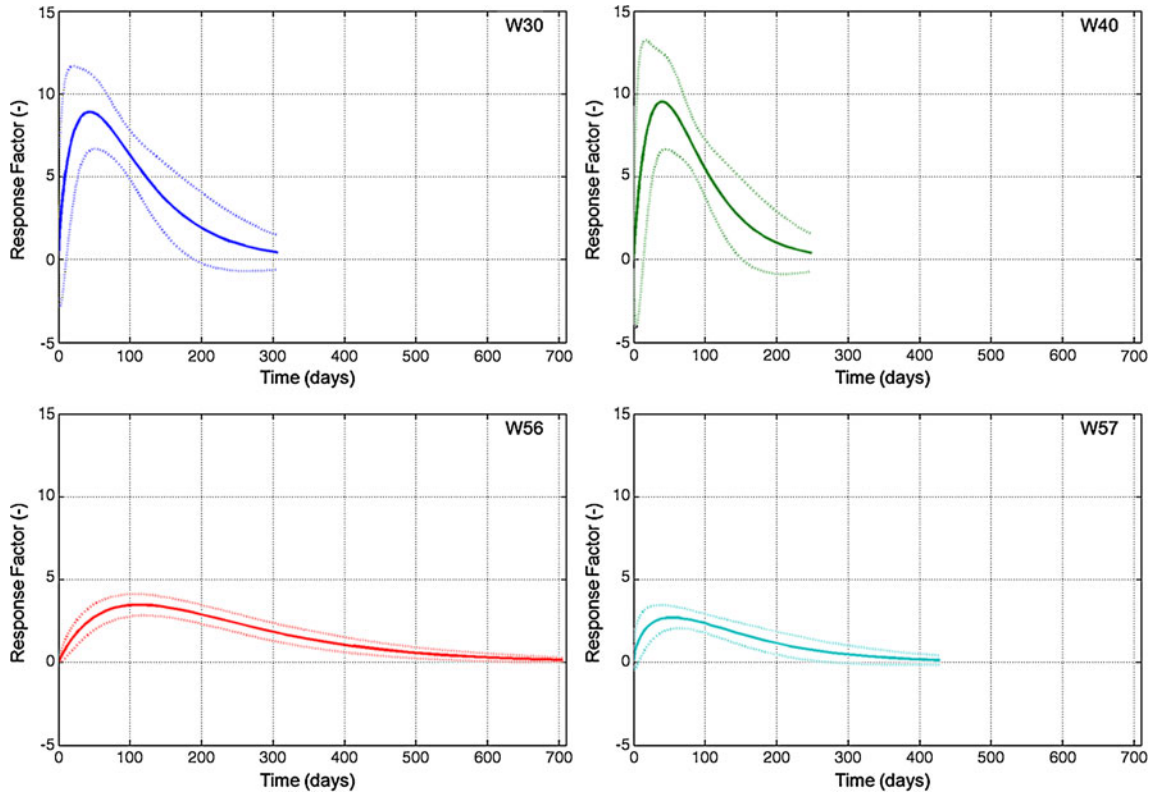

Fig. 5 Temporal adjustment of the impulse response functions for the input series of precipitation for wells W30, W40, W56 and W57 (Solid lines: impulse response functions, dashed lines: upper and lower confidence intervals)

central parts of the basin, reaching a minimum (low) of -8.56 m below the surface. Close to the drainages (excluding the northern part of the basin) and in the southeastern part of the basin, the levels were shallow, presenting levels above the surface (26 cm maximum).

Risk assessment

From the map of water-table depths that will be exceeded with 5% probability on 30 April (Fig. 6), three areas were detected that have a potential risk of shallow water tables (Fig. 7). Fortunately, these areas are close to the drainage

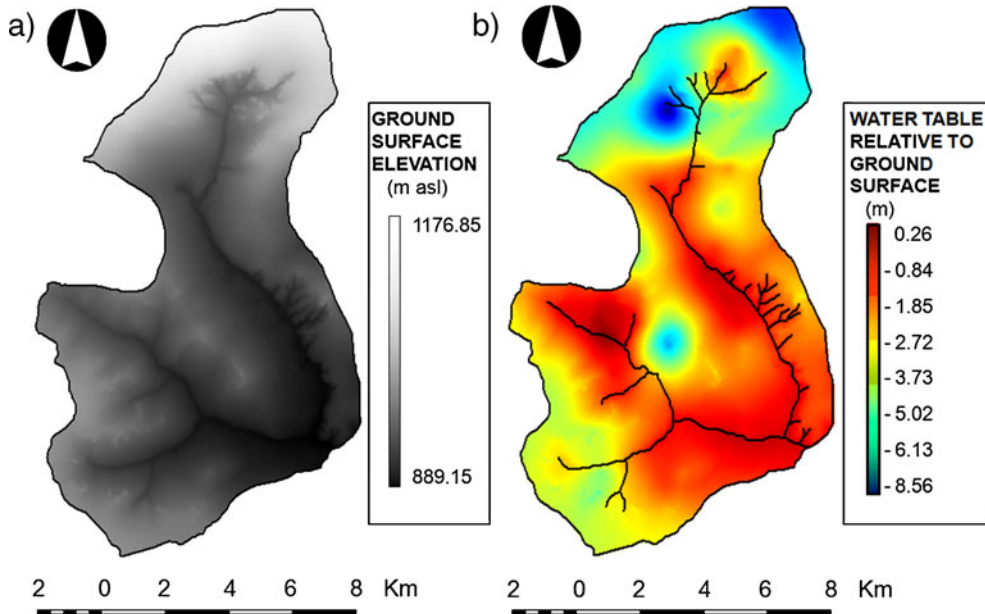

Fig. 6 a Digital elevation model and b estimated water-table depths that will be exceeded with 5% probability on 30 April, varying from -8.56 m below the surface to 26 cm above the surface

Table 2 Parameters of the adjusted semivariograms for the 5th percentile from the simulated water-table depths on 30 April, with and without using elevation as a spatial drift.

Simulated water-table depth values	Model	Nugget	Sill	Contribution	Range (m)
P 0.05	Spherical	6.00	13.00	7.00	2,900
P 0.05E	Spherical	6.00	11.00	5.00	2,900

P 0.05 semivariogram without elevation as a spatial drift (m); *P 0.05E* semivariogram with elevation as a linear trend (m)

devices and under legal protection. Brazilian legislation covers the maintenance of gallery forest along rivers courses. Removing this vegetation is a crime in environmental law, so farmers avoid cultivation in such areas.

The risk spot in the western part of the basin deserves some attention. The LANDSAT image shown in Fig. 7 is from the dry season. The green areas close to the drainage are river valleys and the green polygons are irrigated crops. Most of the lilac areas are ploughed areas waiting for planting after the first rains in September/October. In general, April is a wet period and the polygons inside risk areas are under cultivation by this period. Since this period is close to the end of the cultivation period, before harvesting begins, crops found inside and close to this area are exposed to the potential risk of shallow water tables. If at these places the critical levels are exceeded for more than 10 consecutive days, the plants will start to show severe damage and production losses become a possibility.

The stochastic component of the PIRFICT-model (noise term) simulated over long periods provides information about the behavior of water tables. Many of the most important modern applications of hydrogeology require an assessment of risk as it changes in time and space, and risk is an essentially probabilistic concept (Winter 2004). Information on water levels expressed in terms of probability, for selected dates, provides critical scenarios for the water table when extreme values are regionalized and mapped. From

these maps, the risks of shallow and deep water tables are evaluated and can be extended for any date of interest in the future. Manzione et al. (2008) presented results for extreme deep water levels at the beginning of the rainy season in the Cerrados (around 1 October). With these kinds of results it is possible to optimize water use, to assess choices for long-term water management policy and finally to regulate the competing claims for water resources that often occur between agricultural, industrial and human uses. In this case study, a scenario of shallow water levels on 30 April describes a problem for machinery and plant development. At the end of the wet season shallow water tables can prevent or delay harvest, or delay conditions for plant maturation, for example. Shallow water tables can indicate the need for installation of surface and/or subsurface drainage systems to keep these areas in good agricultural condition. The effects of these events will vary with the magnitude of the event, i.e. the number of consecutive days the area is exposed to this risk situation. From a practical point of view, the risk areas are located where the residence time of the groundwater is long; once groundwater presents itself in such a shallow situation, it can stay for long periods and start to cause damage. A moving window filter with 10 days length inspected all simulated time series searching for more than 10 consecutive days under the risk situation and none of them presented water-table levels higher than 0.5 m (below ground surface) for this time period. In other words, even in

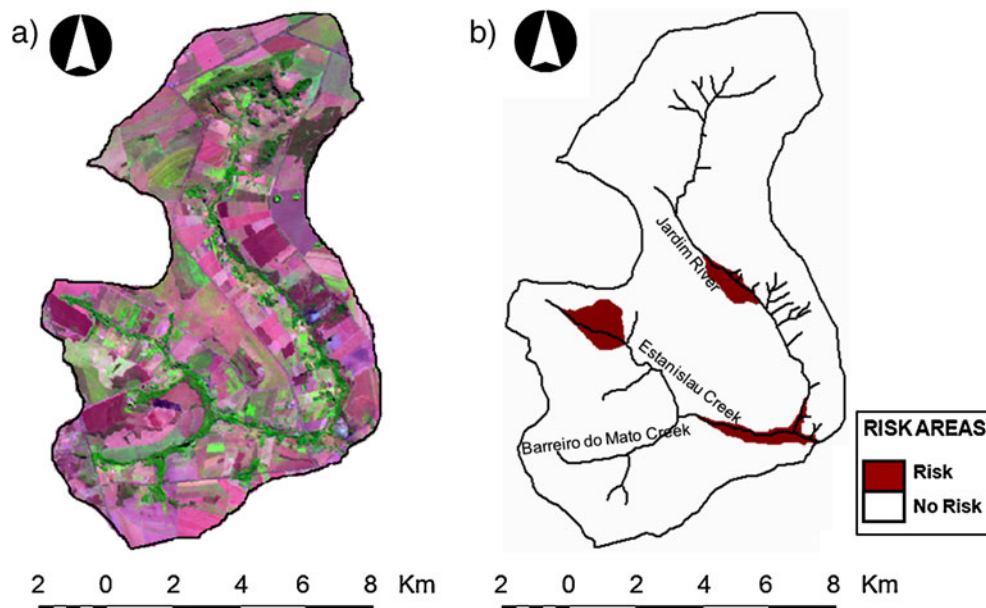

Fig. 7 a LANDSAT 7 R(5)G(4)B(3) image-composition of the basin's land cover in July 2006 (see text for description of colors) and b areas with risk of extreme (shallow) water-table depths on 30 April

potential risk areas, there is a negligible risk of shallow water tables affecting the economic activities in the Jardim River watershed during this period.

Monitoring of water resources and climatological variables and the performance of risk analysis is relevant in regions where the water levels can turn critical or are affected by seasonality during certain periods of the year, affecting the social, economic and ecological interests of the population. Monitoring strategies carried out in water catchments can avoid undesirable situations. Several authors suggest that results from a stochastic experiment expressed in terms of probability and risk should not be standard practice for several reasons (Dagan 2002; Winter 2004; Pappenberger and Beven 2006; Renard 2007). To expand the discussion and to provide understandable information for decision makers, stakeholders and police makers, the results could be made clearer to them, with visualization in maps, for example, instead of simple tables containing numbers and statistical intervals.

Conclusions

Time-series modeling using the PIRFICT-model combined with universal kriging facilitated an understanding and mapping of the dynamic behavior of the water table in the Jardim River watershed, as an input to risk assessment. Due to the flexibility of the Pearson III df, the PIRFICT-model could describe different hydrological behaviors inside a watershed, from the same collection of data.

Simulating extensive time series of water-table depths using a stochastic model enabled water-table depths to be predicted in terms of probability and without the influence of isolated short-term climatic disturbances. The results expressed as risk maps can support decision making in long-term water policy and suggest areas with potential risk of shallow or deep water tables.

For 30 April, three risk spots of shallow water tables were found. The analysis should be extended to other dates/periods that are sensitive to critical water levels. The method presented in this study enables its extension to predict risks at any date in the future for any period of time, providing information on water-table depths for critical dates in the agricultural calendar.

Acknowledgements The first author is grateful to CAPES Foundation/Brazil (Foundation for the Coordination of Higher Education and Graduating Training) and to WIMEK (Wageningen Institute for Environment and Climate Research) for their financial support during his studies at ALTERRA, Wageningen, The Netherlands. The authors are also grateful to EMBRAPA/Cerrados (Brazilian Agricultural Research Corporation) and UnB/IG (University of Brasilia) for sharing this database (PRODETAB - Agricultural Technology Development Project for Brazil).

References

Abramowitz M, Stegun IA (1964) Handbook of mathematical functions. Dover, New York

- Box GEP, Jenkins GM (1976) Time series analysis: forecasting and control. Holden-Day, San Francisco
- Campos JEG (2004) Hidrogeologia do Distrito Federal: bases para a gestão dos recursos hídricos subterrâneos [Hydrogeology of the Brazilian Federal District: basis for groundwater management]. Rev Bras Geoci 34:41–48
- Campos JEG, Tröger U (2000) Groundwater occurrence in hard rocks in the Federal District of Brasilia: a sustainable supply? In: Sililo O (ed) Groundwater: past achievements and future challenges. Balkema, Rotterdam, The Netherlands
- Chilès JP, Delfiner P (1999) Geostatistics: modeling spatial uncertainty. Wiley, New York
- Christensen R (1991) Linear models for multivariate, time series, and spatial data. Springer, New York
- Cressie NAC (1993) Statistics for spatial data (revised edn.). Wiley, New York
- Dagan G (2002) An overview of stochastic modeling of groundwater flow and transport: from theory to applications. EOS Trans AGU 83:621. doi:10.1029/2002EO000421
- Deutsch C, Journel AG (1992) Geostatistical software library and user's guide. Oxford University Press, New York
- Embrapa (1999) Sistema Brasileiro de classificação de solos [Brazilian soil taxonomy]. Embrapa, Brazil
- Furley PA (1999) The nature and diversity of neotropical savannah vegetation with particular reference to the Brazilian Cerrados. Global Ecol Biogeogr 8:223–241
- Goovaerts P (1997) Geostatistics for natural resources evaluation. Oxford University Press, New York
- Hengl T, Heuvelink GBM, Stein A (2004) A generic framework for spatial prediction of soil properties based on regression-kriging. Geoderma 120:75–93
- Hipel KW, McLeod AI (1994) Time series modelling of water resources and environmental systems. Elsevier, Amsterdam
- Jepson W (2005) A disappearing bioma? Reconsidering land-cover change in the Brazilian savannah. Geogr J 171:99–111
- Klink CA, Moreira AG (2002) Past and current human occupation and land-use. In: Oliveira PS, Marquis RJ (eds) The Cerrado of Brazil: ecology and natural history of a neotropical savannah. Columbia University Press, New York
- Knotters M, Van Walsum PEV (1997) Estimating fluctuation quantities from time series of water-table depths using models with a stochastic component. J Hydrol 197:25–46
- Knotters M, Bierkens MFP (2000) Physical basis of time series models for water table depths. Water Resour Res 36:181–188
- Knotters M, Bierkens MFP (2001) Predicting water table depths in space and time using a regionalised time series model. Geoderma 103:51–77
- Manziane RL, Knotters M, Heuvelink GMB, Von Asmuth JR, Câmara G (2008) Predictive risk mapping of water table depths in a Brazilian Cerrado area. In: Stein A, Wenzhong S, Bijker W (eds) Quality aspects in spatial data mining. CRC, Boca Raton, FL
- Matheron G (1969) Le krigeage universel [Universal kriging]. Cahiers du Centre de Morphologie Mathématique 1. Ecole des Mines de Paris, Fontainebleau, France
- Nash JE (1958) Determining runoff from rainfall. Proc Inst Civ Eng 10:163–184
- Odeh I, McBratney A, Chittleborough D (1994) Spatial prediction of soil properties from landform attributes derived from a digital elevation model. Geoderma 63:197–214
- Pappenberger F, Beven KJ (2006) Ignorance is bliss: Or seven reasons not to use uncertainty analysis. Water Resour Res 42:W05302
- Pebesma EJ (2004) Multivariable geostatistics in S: the gstat package. Comput Geosci 30:683–691
- Reatto A, Correia JR, Cera ST, Chagas CS, Martins ES, Andahur JP, Godoy MJS, Assad MLCL (2000) Levantamento semi-detalhado dos solos da Bacia do Rio Jardim-DF, escala 1:50000 [Semi-detailed soil survey of the Jardim River watershed (DF/Brazil), 1:50000 scale]. Embrapa Cerrados, Planaltina, Brazil
- Renard P (2007) Stochastic hydrogeology: What professionals really need? Ground Water 45:531–541

- Souza MT, Campos JEG (2001) O papel dos regolitos nos processos de recarga de aquíferos do Distrito Federal [Regolith dynamics in aquifer recharge processes in the Brazilian Federal District]. *Rev Esc Minas* 54:191–198
- Tankersley CD, Graham WD (1994) Development of an optimal control system for maintaining minimum groundwater levels. *Water Resour Res* 30:3171–3181
- Van Geer FC, Zuur AF (1997) An extension of Box-Jenkins transfer/noise models for spatial interpolation of groundwater head series. *J Hydrol* 192:65–80
- Von Asmuth JR, Knotters M (2004) Characterising groundwater dynamics based on a system identification approach. *J Hydrol* 296:118–134
- Von Asmuth JR, Bierkens MFP (2005) Modelling irregularly spaced residual series as a continuous stochastic process. *Water Resour Res* 41:W12404
- Von Asmuth JR, Bierkens MFP, Maas C (2002) Transfer function noise modelling in continuous time using predefined impulse response functions. *Water Resour Res* 38: 23.1–23.12
- Von Asmuth JR, Maas K, Bakker M, Petersen J (2008) Modeling time series of ground water head fluctuation subjected to multiple stresses. *Ground Water* 46:30–40
- Von Asmuth JR, Maas C, Knotters M (2010) *Menyanthes Manual*, version 1.9. KWR Watercycle Research Institute, Nieuwegein, The Netherlands
- Wackernagel H (2003) *Multivariate geostatistics: an introduction with applications*. Springer, Berlin
- Winter CL (2004) Stochastic hydrogeology: practical alternatives exist. *Stoch Environ Res Risk Assess* 18:271–273
- Yi M, Lee K (2003) Transfer function-noise modeling of irregularly observed groundwater heads using precipitation data. *J Hydrol* 288:272–287