



# Analysis and design of dual-feature fusion neural network for sports injury estimation model

Linsheng Meng<sup>1</sup> · Endong Qiao<sup>1</sup>

Received: 10 February 2021 / Accepted: 24 May 2021 / Published online: 7 July 2021  
© The Author(s), under exclusive licence to Springer-Verlag London Ltd., part of Springer Nature 2021

## Abstract

High-level athletes participate in various events that need extreme fitness and stamina. Usually, after competitions, the athletes take part in systematic physical fitness and specialized skills training. The daily training sessions of an athlete are often of higher intensity level. This kind of long-term and high-intensity training affects an athlete both physically and mentally and overloads him/her, leading to sports injuries. As a result, an athlete is no longer capable to perform high-intensity training due to these injuries and unable to achieve the desired results in the competition. Therefore, the need for an intelligent system arises to evaluate, predict and detect sports injuries effectively. The significance of neural networks for target recognition motivates us to propose a novel dual-feature fusion neural network model for athlete injury estimation. Our proposed model solves the problem of feature loss by using a  $1 \times 1$  convolution and hyperlink to form a dual-fusion structure to enhance effective discrimination. Multiple experiments have been performed using different classification models. The performance of the utilized models, including the proposed model, has been evaluated with the help of numerous performance evaluation metrics. Various preprocessing techniques have been used in this study. The proposed model attained an excellent classification accuracy of 97.0%, a sensitivity of 95.70%, and a specificity of 97.54%. Experimental results show that the performance of the proposed model is much better than the rest of the classification models used in this study.

**Keywords** Sports injury estimation · Deep learning · Dual-feature fusion · Neural network

## 1 Introduction

Sports injuries are common, and some of them are repeated with time. Throughout their lives, athletes can sustain multiple sports injuries that can affect their careers and harm them physically, emotionally, and financially. In sports injuries, accidental events are generally considered to significantly impact subsequent injury (of the same or a different type). These repeated injuries are unlikely to be statistically independent. Hence, statistical and intelligent techniques suitable for analyzing and processing the data relevant to these injuries need to be used. Various modeling methods have been used to report recurring event data, such as modeling the total number of events. However,

these methods have been naive in the predictive context because they do not allow for the association between events or have omitted essential detailed information about the corresponding events. Important statistical developments have been made in the last couple of years in modeling repeated event data.

High-level athletes participate in various forms of competitions at both local and global platforms. After taking part in competitions, they need to conduct systematic physical fitness and special skills training to track and maintain their physical and mental status. They also need to work out daily training, which is often at a higher intensity level. This kind of long-term and high-intensity training puts a higher physical strain on the athlete's body. It is always in a state of higher load that it is easy to cause sports injuries to athletes [1]. Conversely, an athlete will not be able to do the high-intensity training with ease due to sports injuries and will not achieve good performance in high-level competitions, which will affect the improvement

✉ Endong Qiao  
1923701003@email.sxu.edu.cn

<sup>1</sup> Sports Academy, Shanxi University, Shanxi 030000, China

of athletes' performance [2–5]. From the perspective of fitness, the physical fitness level of high-level athletes determines the level of their skills. Therefore, the development of sports skills must be based on the physical fitness of an athlete. An athlete's fitness level also depends on the game he/she may play, as some sports require more fitness level, and some need less fitness level. For example, sprint sports have an extremely higher requirement of athletes' physical fitness. Sprints are one of the highest intensity sports, and athletes often perform high-intensity training, which inevitably brings an increased risk of sports injuries. Studies have shown that the major injuries that sprinters often face are iliac crest, band friction syndrome, ligament injury, knee injury, ankle injury, hip injury, waist injury, tenosynovitis, abrasions, and contusions, etc.

These sports injuries need to be diagnosed at the early stages. If they are not diagnosed at the initial stages and left unaddressed, it will continuously affect the systematic high-intensity training of sprinters and shorten the career of these athletes. Therefore, sports injuries have become the main factor that frequently limits the performance improvement of high-level athletes. Hence, the need for sports injury detection methods to predict injuries of high-level athletes has arisen. Detecting the athletes accumulating poor posture or sports injuries during the training and accurately positioning the injured parts can determine the cause of body posture problems. Tracing the athlete's problems in training combined with special intervention measures to address potential sports injuries can help to reduce the incidence of sports injuries, prevent sports injuries, and improve sports training levels.

The advancement in technologies and rapid development of intelligent models such as machine learning (ML) and deep learning (DL)-based intelligent predictive systems have attracted significant attention of researchers and industries. These advanced techniques-based models possess unique properties such as robustness, self-organization, self-adaptability, parallel processing capabilities, distributed storage, excellent fault tolerance, non-linear approximation capabilities, and some other attractive features. At present, DL algorithms are used widely and have many applications in various fields such as agriculture, healthcare, industries, military agencies and have achieved good results. Among the DL algorithms, artificial neural network (ANN) is most widely used for various purposes. Murphy et al. [1] have summarized the previous studies and divided the risk factors that induce sports injuries into two categories, i.e., internal and external factors, in terms of sports injury risk prevention. In another study, the author established a dynamic chain model to explain the interaction between injury risk factors and the contributions of those factors toward the

injuries [2]. Therefore, it is effective to use a DL-based approach such as neural networks to identify and estimate athletes' injuries.

This paper proposes a novel dual-feature fusion neural network model for athlete injury estimation to overcome the issues mentioned above. Our proposed algorithm solves the problem of feature loss caused by the merging operations leading to a decrease in classification accuracy. It uses  $1 \times 1$  convolution and hyperlinks to form a double fusion structure, resulting in enhanced and effective discrimination. The experimental results show that the algorithm can effectively identify athletes' injuries and give more accurate estimates/predictions. Following are some of the main contributions of our research work:

- We propose a novel dual-feature fusion neural network model for identifying and recognizing the athlete's injuries, capable of extracting more representative deep features from the data and resulting in higher recognition accuracy.
- Given the complex environment of martial arts athletes' movement loss recognition, this paper proposes a novel approach to convert the image of each gesture of the athlete to two color subspaces, texture and gray, and extract texture and gray features to improve the model's identification ability.
- We have conducted enough comparative experiments and studies on the collected athlete injury dataset that proved the effectiveness and superiority of the dual-feature fusion neural network model proposed in this study.

The remaining paper is structured as follows: Sect. 2 demonstrates the background study, Sect. 3 notifies the material and methods, and Sect. 4 represents the experiments and results. Finally, we conclude our paper in Sect. 5.

## 2 Background

Sports injuries are usually not a result of a simple factor but often occur as a result of multiple factors [6–8]. For making a more accurate prediction of the occurrence of sports injuries, we must first study the factors that directly or indirectly lead to the occurrence of these injuries. The analysis of related factors of sports injury risk warning is the basis of the entire sports injury intelligent prediction. Based on the literature study, interviewing coaches and athletes, and other theoretical knowledge and analysis it is found that as many as more than 20 factors can directly or indirectly cause sports injuries, and many of these data are qualitative data, which cannot be accurately expressed using traditional linear models. Neural networks can solve

the problem of finding the relationship between the factors and injuries in an effective way, but when applying these neural network algorithms, it is necessary to use a sample library for training. The quality of the sample library directly affects the results such as the accuracy of the neural network algorithms. The demand data of the sample database are the information of all athletes' sports injuries risk early warning-related factors and their corresponding early warning levels. At the earlier stage, the required factor information can be obtained via a questionnaire, and the factor information related to the physiological and biochemical indicators can be obtained from the weekly measurement data of the sports team members, but how to accurately determine the early warning level through these indicators are a difficult task. The perceptual judgment of coaches and experts to find the fitness level of an athlete is usually not accurate enough. In order to overcome the above-mentioned issues, this study first established a linear dynamic chain model using the collected sports injury-related factor information to qualitatively determine the warning level. Through the earlier prediction and evaluation results of coaches, experts, and linear model, the final prediction level is obtained, which results in a trained model and is then tested on the sample database of sport injuries.

Deep learning (DL) algorithms play a tremendous role in the diagnosis and prediction of various diseases. Among the DL algorithms, artificial neural network (ANN) is an important and most widely used algorithm. The advantage of ANN lies in its excellent information processing characteristics, which are mainly related to non-linearity, high parallelism, fault tolerance, noise tolerance, and its ability to learn and generalize [9–14]. The word “neural” in the name ANN implies that they are systems, inspired by the structure of the brain to replicate the way humans learn. The human brain contains more than 100 billion neurons and is very fast as compared to the computer structured perceptron. The computing power of a single neuron is very limited, but a neural network composed of hundreds of billions of neurons can achieve extremely complex functions. The ANN is a mathematical model constructed by perceptron that imitates the characteristic of human brain, which connects a large number of neurons (perceptron) into a whole and form a network of neurons which operates with a faster speed and can solve complex problems. The network calls thousands of neurons for calculations and has excellent performance that can approximate various complex functions. Artificial neural network is a powerful tool in the field of pattern recognition. Those patterns that are too complex or too many for humans to extract can be handed over to the machine for recognition. Although ANN has been proposed around 1940, it

has not been until recent decades that ANN has become the key technology of AI, which has an inseparable relationship with the “back propagation” technology. This technology allows the perceptron to modify the parameters of its neuron hidden layer when the actual effect does not match the desired effect. Different layers of the multi-layer network will extract different features until the ANN can recognize it [15–19]. So far, DL algorithms specifically neural networks have been widely used in sports and other aspects.

### 3 Material and methods

The main theme and objectives of the proposed system are to design and develop a novel dual-feature fusion neural network model for the identification and prediction of athletes' injuries that can extract more representative deep features and achieve promising and higher prediction results. Sprinter injuries dataset has been used in this study. In order to provide the data in a normalized form to the classification models various preprocessing techniques are used. The dataset is divided into two main parts i.e. training and testing. In this study, 70% of the data is used for training while the rest of the 30% is used for testing and validation purposes. In this study, a novel dual-feature fusion neural network model is proposed for estimating sports injuries of an athlete. However, various other machine learning and deep learning algorithms are also investigated for the prediction of sports injuries of an athlete. Various performance measures are used to measure the performance of the utilized models. Figure 1 shows the graphical representation of the proposed methodology.

#### 3.1 Proposed dual-feature fusion neural network model

Figure 2 shows the overall workflow of athlete injury recognition based on the proposed dual-feature fusion neural network model. From Fig. 2, it is obvious that the proposed algorithm first extracts the grayscale and texture features of the athlete's image and transmits them to the feature fusion block network for training; after training, it finally predicts the injury probability of an athlete. The main body is composed of feature fusion blocks, convolutional long short-term memory (ConvLSTM), fully connected (FC) layers; and the number of feature fusion blocks are related to the complexity of the athlete's image.

The architecture and working of the proposed dual-feature fusion neural network model for sports injury estimation is discussed in the following subsections.

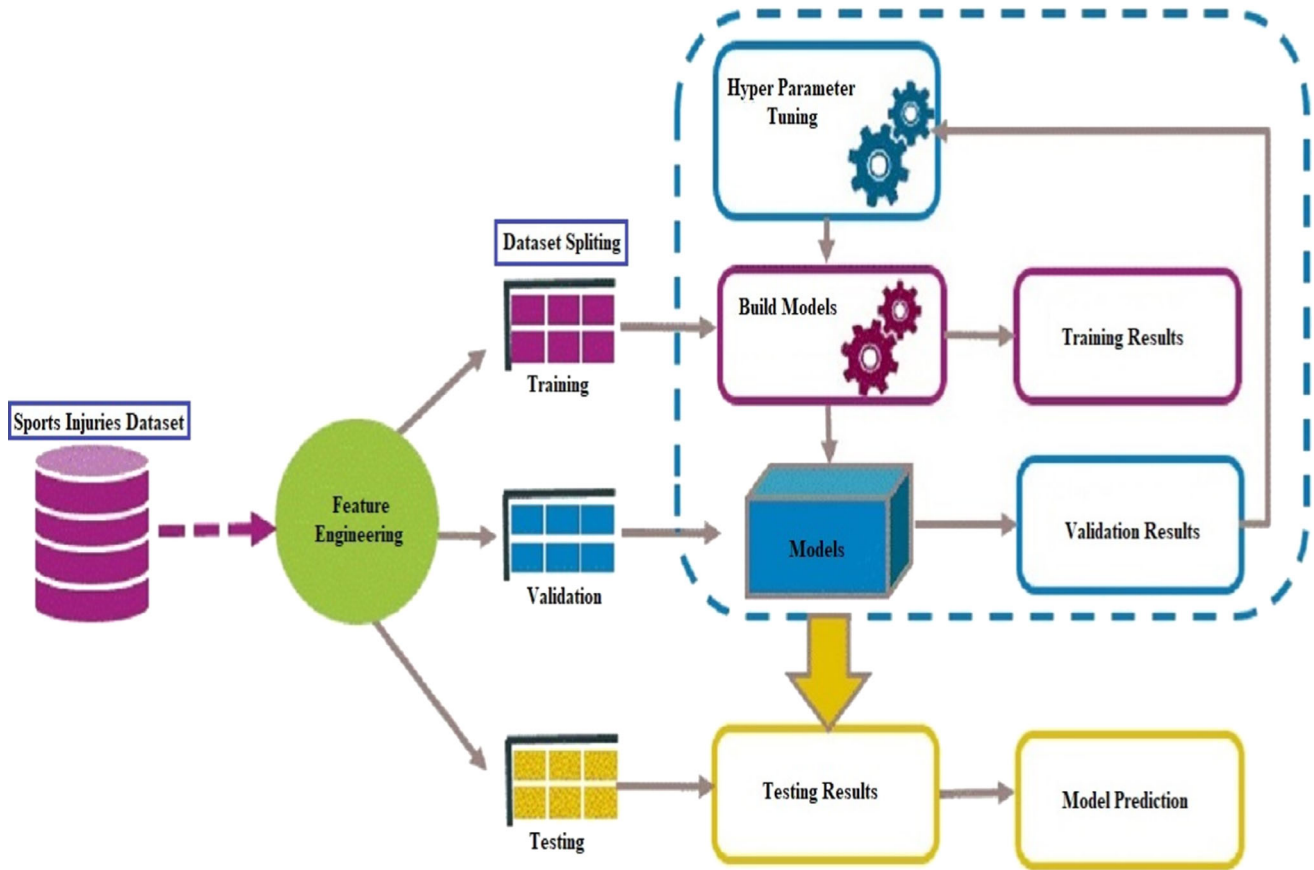

Fig. 1 Methodology of the proposed system

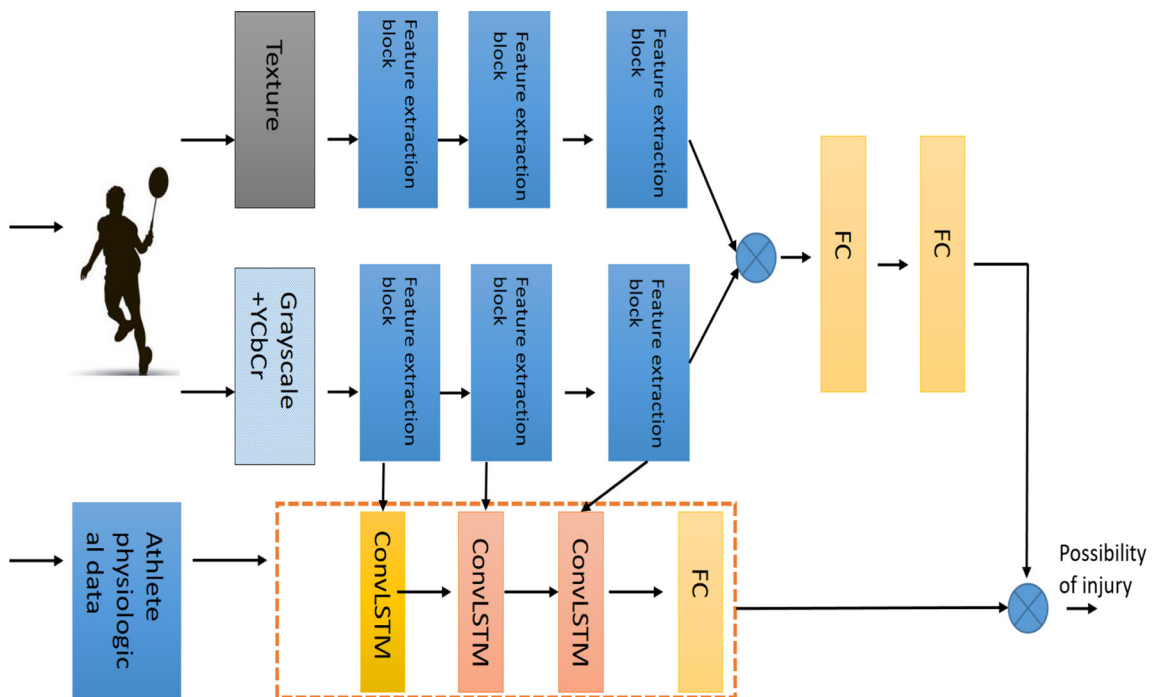

Fig. 2 Overall architecture and workflow of the proposed model

### 3.1.1 Feature extraction

In this study, feature extraction is basically composed of texture features and grayscale features.

**3.1.1.1 Texture features** Texture is a natural characteristic of the surface of an object. It describes the distribution of the grayscale space between the image pixels and the image field and does not change the vision of the image due to the intensity of light. Therefore, we have extracted the texture features of the wheat field image, and the equation for extracting the texture features is as follows:

$$TF(x_c, y_c) = \sum_{p=0}^{P-1} 2^p s(i_p - i_c), s(x) = \begin{cases} 1 & x \geq 0 \\ 0 & x < 0 \end{cases} \quad (1)$$

where  $(x_c, y_c)$  is the central pixel,  $i_c$  is the brightness of the point,  $i_p$  is the brightness of the adjacent pixels, and  $s$  is the sign function.

In a 3\*3 window, take the central pixel of the window as the threshold, and compare the gray value of the adjacent 8 pixels with it. If the surrounding pixel value is greater than the central pixel value, the position of the pixel is marked as 1, otherwise, it is 0. The vector block composed of 1 and 0 is the texture feature we extracted.

**3.1.1.2 Grayscale features** The grayscale image only contains brightness information, not color information, which helps to improve the performance of image segmentation. The calculation equation is as follows:

$$GF = \frac{R \times 30 + G \times 59 + B \times 11}{100} \quad (2)$$

where  $R$ ,  $G$  and  $B$  represent the red, green and blue channels of the wheat plantation row image, respectively.

**3.1.1.3 YCbCr color space** In general, the distribution of the skin color of athletes in the YCbCr space is mainly in the elliptical area of the CbCr plane. In order to point out that, whether the CbCr of the current pixel is within the elliptical area, it can be judged whether the current pixel is a human skin color or not. The following formula is used for the conversion of RGB color to YCbCr color space:

$$\begin{cases} Y = 0.257 \times R + 0.564 \times G + 0.098 \times B + 16 \\ Cb = -0.148 \times R - 0.291 \times G + 0.439 \times B + 128 \\ Cr = 0.439 \times R - 0.368 \times G - 0.071 \times B + 128 \end{cases} \quad (3)$$

By setting the threshold interval of Cr and Cb, all the pixels of the image are traversed to extract the skin color area of an athlete.

Figure 3 shows the overall structure of the feature extraction and fusion block, which consists of the above

two structures. The upper structure is responsible for transmitting the original local spatial connection and is composed of a hyperlink with  $1 \times 1$  convolution; while the lower structure is responsible for extracting and strengthening more representative discriminative features, consisting of two convolutional layers and a pooling layer, and a two-layer structure with an up-sampling layer and a transposed convolution layer.

First, we set the size of the input image block to  $15 \times 21 \times 21$  (spatial size is  $21 \times 21$ , layer is 15), and the filter size in the first convolutional layer is set to  $16 \times 5 \times 5$ , step size is set to (1, 1), the input image block is convolved with the filter to obtain a new feature map with a size of  $16 \times 21 \times 21$ . Then, the pooling layer with the scale factor (3, 3) is used to extract the maximum feature of the feature map to obtain a feature map with a size of  $16 \times 7 \times 7$ , including transposed convolution and up-sampling. Such a two-layer structure will strengthen the feature map. The filter size of the former is set to  $16 \times 3 \times 3$ , the step size is set to (3, 3), and the latter is along the rows and columns of the feature map. Repeating these largest features three times, the two feature maps are combined into a  $32 \times 21 \times 21$  fusion feature map. The fusion feature map is passed to the second convolutional layer with a filter size of  $64 \times 5 \times 5$ , and before Relu activation function processing, the size obtained by the  $64 \times 1 \times 1$  filter in the above structure is 64. The  $21 \times 21$  feature maps are merged to obtain the final output feature map. In addition, these experiments also use batch normalization (BN) and Relu activation function at each layer of convolution to speed up the training process and improve generalization ability.

### 3.1.2 Multiscale convolution long short-term memory (ConvLSTM)

Long short-term memory (LSTM) is a special structure of the recurrent neural network (RNN). It shows outstanding performance on 1-D sequence data processing by learning the long-range dependency among adjacent or nonadjacent sequences. However, when dealing with ocean remote sensing image data, the full connection in LSTM fails to take rich background information into account. ConvLSTM was proposed for the purpose to replace the full connection in LSTM with the convolution operation [30]. It works with the memory cell  $c_t$  and three control gates (input gate  $i_t$ , forget gate  $f_t$ , output gate  $o_t$ , cell  $c_t$ , and hidden gate  $h_t$ ). Based on convolution operation, the equation used for calculation is as follows:

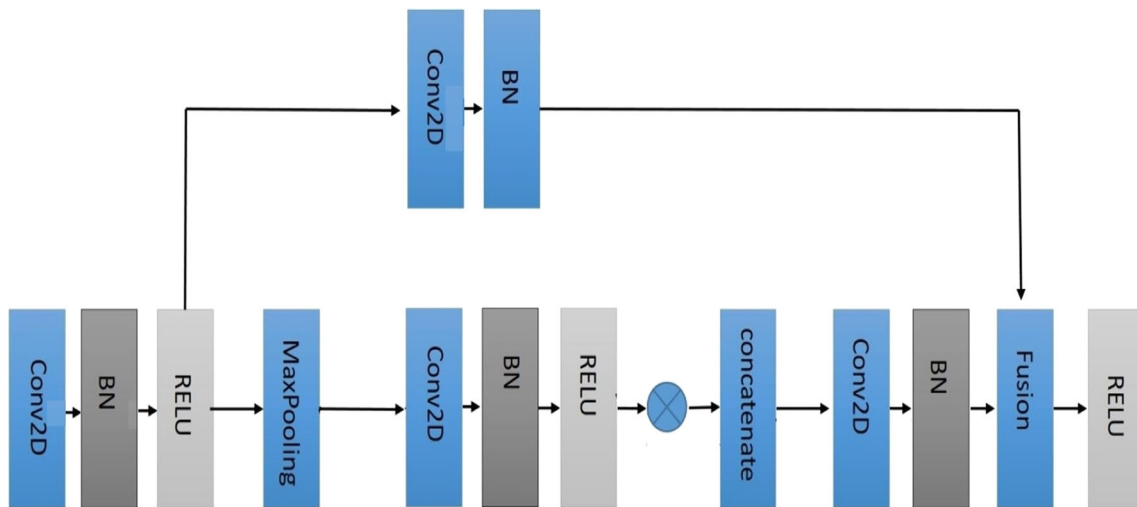

Fig. 3 Feature extraction block

$$\begin{aligned}
 i_t &= \sigma(W_{xi}x_t + W_{hi}h_{t-1} + W_{ci} \circ c_{t-1} + b_i) \\
 f_t &= \sigma(W_{xf}x_t + W_{hf}h_{t-1} + W_{cf} \circ c_{t-1} + b_f) \\
 c_t &= f_t \circ c_{t-1} + i_t \circ \tanh(W_{xc}x_t + W_{hc}h_{t-1} + b_c) \\
 o_t &= \sigma(W_{xo}x_t + W_{ho}h_{t-1} + W_{co} \circ c_t + b_o) \\
 h_t &= o_t \circ \tanh(c_t)
 \end{aligned}
 \tag{4}$$

where  $\circ$  represents the Hadamard product. This LSTM structure can also be called FC-LSTM. It can handle time series data well, but for ocean remote sensing images, it will bring redundancy. The reason behind this is that ocean remote sensing images have strong background local features, but FC-LSTM cannot describe this local feature. The ConvLSTM proposed in this study attempts to solve this problem by replacing the input-to-state and state-to-state parts of FC-LSTM with feedforward calculations into convolutional forms. The internal structure of ConvLSTM is shown in Fig. 4.

The working principle of ConvLSTM can be expressed by the following equation:

$$\begin{aligned}
 i_t &= \sigma(W_{xi} * x_t + W_{hi} * h_{t-1} + W_{ci} \circ c_{t-1} + b_i) \\
 f_t &= \sigma(W_{xf} * x_t + W_{hf} * h_{t-1} + W_{cf} \circ c_{t-1} + b_f) \\
 c_t &= f_t \circ c_{t-1} + i_t \circ \tanh(W_{xc} * x_t + W_{hc} * h_{t-1} + b_c) \\
 o_t &= \sigma(W_{xo} * x_t + W_{ho} * h_{t-1} + W_{co} \circ c_t + b_o) \\
 h_t &= o_t \circ \tanh(c_t)
 \end{aligned}
 \tag{5}$$

where  $*$  means convolution. It is worth noting that  $x, h, i, f$  and  $o$  here are all three-dimensional tensors, and their last two dimensions represent the spatial information of rows and columns. We can think of ConvLSTM as it is a model for processing feature vectors in a two-dimensional grid. It can predict the features of the center grid

based on the features of the surrounding points in the grid.

This article uses three layers of ConvLSTM, the output of the first and second layers of ConvLSTM and the output of the third layer of ConvLSTM are spliced to feed into the next Conv1D layer, and finally, the final segmentation prediction is performed through the sigmoid function.

### 3.1.3 Athlete injury grade assessment

On the basis of features value, the sports injury risk warning levels are divided into four categories. The four categories are (1) no risk: it shows that the athlete is healthy and has no sports injury, (2) low risk: it shows that the athlete has minor injury and is not harming, (3) medium risk: it shows that the athlete has some injuries which needs to be treated in order to save the athlete from further damage, (4) High risk: it shows that the athlete is in high risk and needs to be provided immediate medication and services. Table 1 demonstrates a list of these risk factors.

This study proposes a novel dual-feature fusion neural network model for the athletes injury estimation. The proposed model solves the problem of feature loss caused by the merging operation that results in a decrease in classification accuracy. It uses  $1 \times 1$  convolution and hyperlinks to form a double feature fusion structure to enhance effective discrimination. Experimental results show that the proposed model can effectively identify athletes' injuries and give more accurate results in terms of various performance measures.

Fig. 4 ConvLSTM cell structure

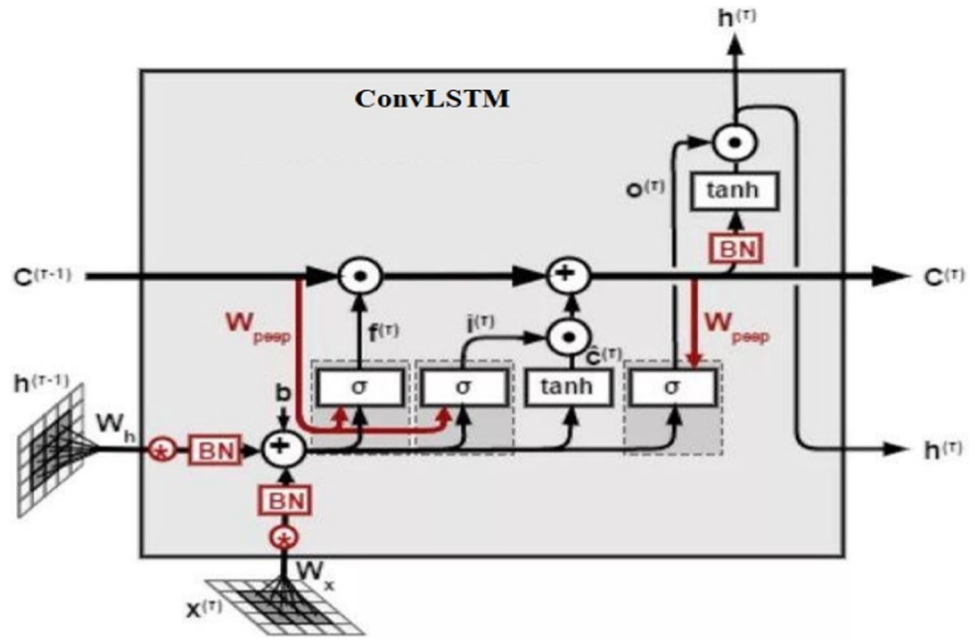

Table 1 Risk factors and its output values

Sports injury risk warning level	Output value
No risk	0
Low risk	1
Medium risk	2
High risk	3

$$\text{Specificity} : \frac{TN}{TN + FP} \tag{8}$$

$$\text{Precision} : \frac{TP}{TP + FP} \tag{9}$$

$$\text{Recall} : \frac{TP}{TP + FN} \tag{10}$$

$$\text{F1 - Score} : \frac{2(\text{Precision} * \text{Recall})}{\text{Precision} + \text{Recall}} \tag{11}$$

3.1.4 Performance evaluation metrics

The last step after training and testing is to check the performance of the models in terms of various performance evaluation metrics. These performance measures help in determining the performance of the utilized models. In this study, different performance evaluation metrics such as accuracy, sensitivity, specificity, precision, recall, AUC, f1-measure, Mathew correlation coefficient (MCC), and ROC curve are used to track the performance of the utilized models. All the investigate performance metrics are computed with the help of confusion matrix. ROC curve is used to measure the performance of the proposed system graphically. Following are the formulas through which these measures are computed:

$$\text{Accuracy} : \frac{TP + TN}{TP + TN + FP + FN} \tag{6}$$

$$\text{Sensitivity} : \frac{TP}{TP + FN} \tag{7}$$

4 Experiments and results

This section represents the experimental results attained through various ML and DL models. Multiple experiments were performed using seven distinct models which include: SVM, SVM, 3D-CNN, AlexNet, ResNet, 3D-DenseNet, DenseNet, and the proposed DFFNN. Performance of the investigated models was checked on the athlete sports injuries dataset. The dataset was divided into two parts i.e. training and testing, where 70% of data is used to train the models while the remaining 30% is used for the testing and validation purpose. To measure the performance of the utilized models, numerous performance metrics were used. In addition, preprocessing techniques are also used on the data before giving it to the classification algorithms. The performance of the proposed model was superior as compared to the rest of the models in terms of all performance measures.

## 4.1 Experimental environment

To perform an experiment there is need of an environment and tools that help in carrying out the experiments and simulation results. This study uses the Pycharm IDE for the simulation and Python as a programming language for the implementation of the proposed model. Further, this study uses Python 3.7, various packages such as Keras, matplotlib, seaborn, pandas, NumPy, and TensorFlow. All the experiments have been conducted on a desktop PC with an Intel Core i7-8700 processor and an NVIDIA GeForce GTX 1080ti GPU.

**Table 2** Basic information of an athlete

Name	Sex	Age	Height	Weight	Injury Type
L01	Male	20	170	69	0
L02	Male	21	160	65	1
L03	Male	22	168	72	2
L04	Male	23	165	57	2
L05	Male	25	163	60	1
L06	Male	21	172	52	3
L07	Male	19	160	65	1
K01	Male	21	160	69	0
K02	Male	22	170	65	1
K03	Male	21	160	69	0
K04	Male	21	168	65	1
K05	Male	24	170	69	1
K06	Female	24	168	72	1
K07	Female	24	170	69	0
K08	Female	19	168	72	2
K09	Female	21	170	72	2
C01	Female	19	160	69	2
C02	Female	21	170	72	3
C03	Female	19	168	72	0
C04	Female	21	170	69	3
C05	Female	19	160	65	3
C06	Female	19	170	65	0
C07	Female	21	160	72	3
C08	Male	21	168	69	3
C09	Male	23	170	65	1
N01	Male	23	160	72	0
N02	Male	21	170	69	1
N03	Female	21	168	65	2
N04	Female	23	170	69	0
N05	Female	21	170	72	2
N06	Female	23	168	69	3
N07	Female	23	168	65	3
N08	Female	21	170	65	3

## 4.2 Research object

This research study takes the effect of functional movement training of the sports injuries of sprinters as the research object, and the sprinters of the Hainan Provincial Team as the experimental object. In this study, 33 athletes were selected as the test subjects, including 16 male sprinters and 17 female sprinters. All the athletes are of national level 2 or above and are active athletes. Table 2 demonstrates the basic information of an athlete.

The functional action screening kit shown in Fig. 5a and b was selected to conduct a functional action screening test for the sprinters of the Hainan Provincial Team, requiring the athletes to perform the test according to the standards of each action mode.

The functional action screening test was conducted on a total of 33 athletes. As a single action test takes a long time, in order to ensure the accuracy of the test and reduce the processing time, the sprinters are divided into a group of 10 peoples, a total of 4 test groups, staggered test time, complete functional movement tests for all athletes within 2 working days. Fill out the athletes test score sheet and prepare it for the statistical analysis. Functional action screening test is divided into seven actions, namely top-lift squat, straight lunge squat, up-step hurdles, active straight knee lift, shoulder flexibility, push-ups, and rotational stability. The scoring standard is divided into 4 standards, which are 0 points, 1 point, 2 points, and 3 points. Among them, 0 points to any pain during the test, 1 points to unable to complete the action but no pain, 2 points to lower the standard to complete the action, 3 points to complete the action according to the standard. The test is divided into 3 stages according to the training process. After each training stage, all sprinters are tested for functional activity, and the scores of functional action screening of the sprinters in the 3 stages are counted. In addition, the whole process is photographed to produce a corresponding visual dataset. The acquired athlete injury data are then fed to the second branch of the neural network algorithm proposed in this study.

## 4.3 Experimental results of all the utilized models

This section represents the experimental results attained via different models used in this study in order to verify the proposed system. To show the effectiveness of the proposed model, multiple experiments were conducted on the health data of 33 athletes of Hainan Province collected in this study. Further, to prove the efficiency and significance of the proposed dual-feature fusion neural network model used in this study, we used six other classification models,



**Fig. 5** **a** Functional motion screening (FMS) kit. **b** Functional motion screening (FMS) kit

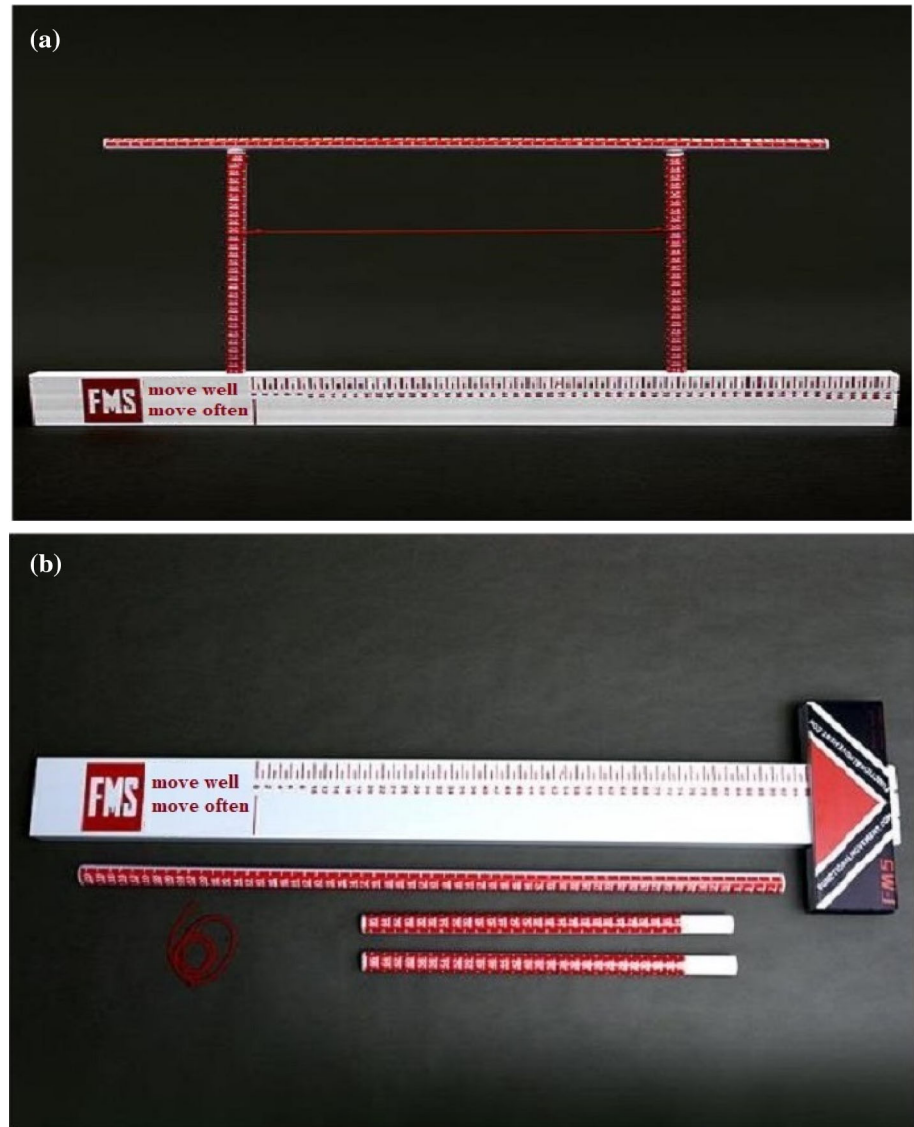

**Table 3** Experimental results of all the utilized models

Model	Accuracy	Sensitivity	Specificity	AUC	Precision	Recall	f1-Score	MCC
SVM	88.02	87.32	86.37	88.00	88.68	87.32	0.88	0.76
3D-CNN	91.08	92.42	89.20	91.78	90.70	92.42	0.91	0.82
AlexNet	92.16	91.50	93.60	92.66	91.90	91.50	0.92	0.85
ResNet	93.12	95.43	93.75	95.90	93.86	95.43	0.93	0.88
3D-DenseNet	95.04	96.40	93.70	95.80	94.71	96.40	0.95	0.90
DenseNet	96.11	94.54	97.65	97.80	98.50	94.54	0.96	0.92
Ours	97.00	95.70	97.54	98.26	98.40	95.70	0.97	0.93

namely SVM [], 3D-CNN [20], AlexNet [21], ResNet [22], 3D-DenseNet [23], and DenseNet [24]. Table 3 gives a quantitative comparison of all the experimental results attained through all the models used in this study.

It can be seen from the experimental results that our proposed model obtained the highest performance results

in terms of all performance measures as shown in Table 3. Table 3 demonstrates that our proposed model i.e. dual-feature fusion neural network performed exceptionally well in terms of all performance metrics as compared to the rest of the models used in this study. The proposed model conquered the classification accuracy of 97.00%, the

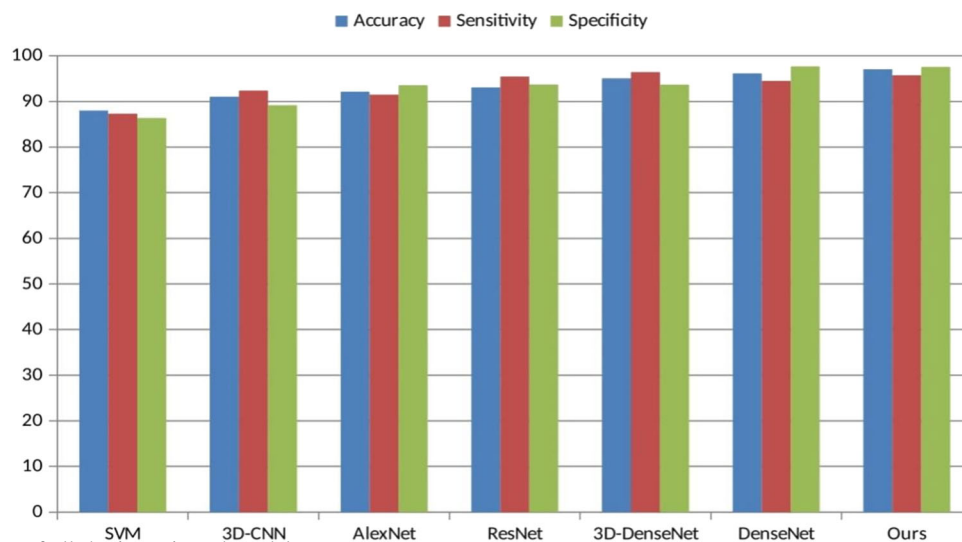

**Fig. 6** Performance of all the investigated models

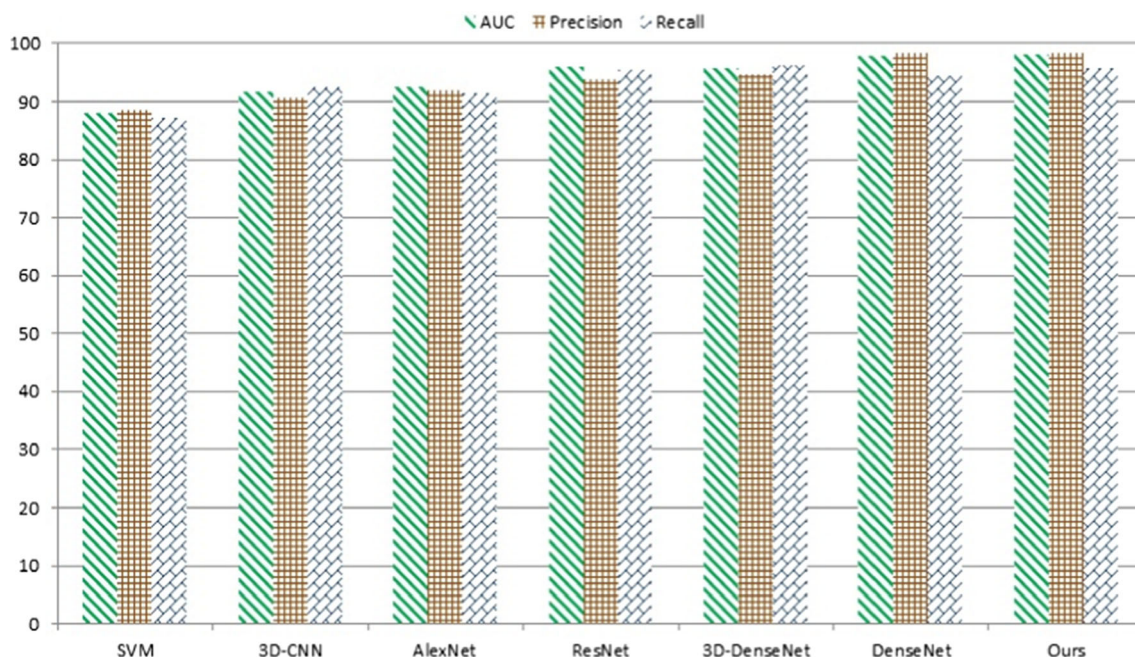

**Fig. 7** Precision, recall, and AUC-score of the investigated models

sensitivity of 95.70%, specificity of 97.54%, AUC of 98.26%, the precision of 98.40%, recall of 95.70%, f1-score of 0.97, and MCC of 0.93 as shown in Table 3. The second-best performance was observed for the DenseNet algorithm. DenseNet attained the accuracy of 96.11%, sensitivity of 94.54%, specificity of 97.65%, AUC of 97.80%, precision of 98.50%, recall of 94.54%, f1-score of 0.96, and MCC of 0.92. SVM showed the lowest performance in terms of all performance metrics by attaining

the classification accuracy of 88.02%, the sensitivity of 87.32%, specificity of 86.37%, AUC of 88.00%, the precision of 88.68%, recall of 87.32%, f1-score of 0.88, and 0.76 of MCC.

Figure 6 signifies the performance (accuracy, sensitivity, and specificity) of all the investigated classification models using the athlete sports injuries dataset. From Fig. 5, it is obvious that our proposed model beats all the other classification models used in this study in terms of all

**Fig. 8** f1-measure and MCC-score of the investigated models

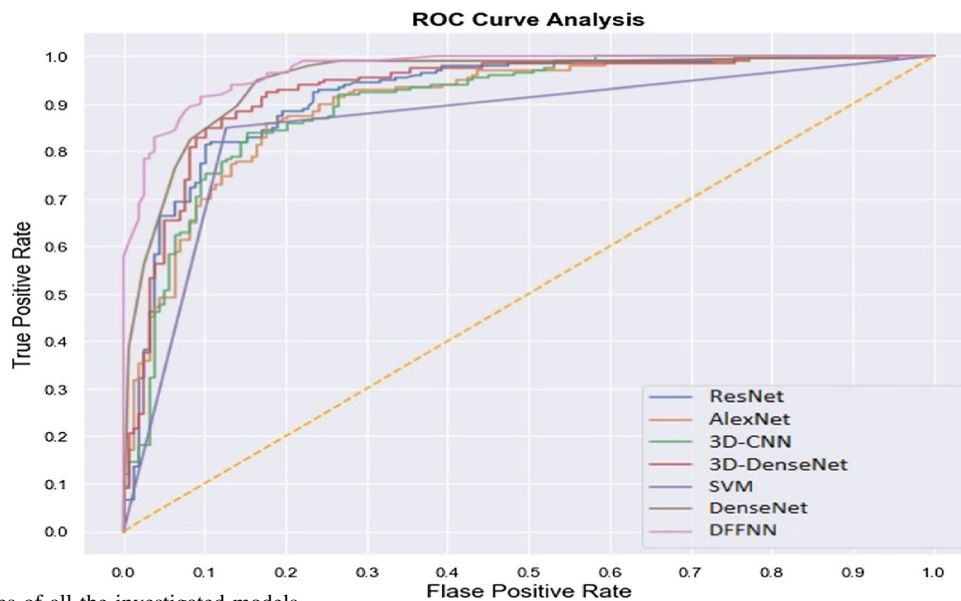
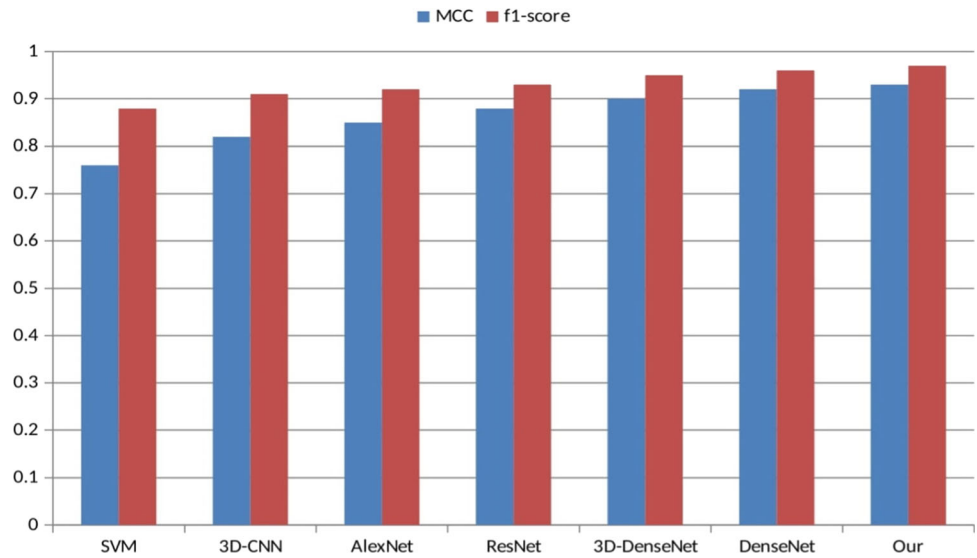

**Fig. 9** ROC curves of all the investigated models

performance metrics, whereas the lowest performance was observed for the SVM classification model.

Figure 7 shows the precision, recall, and AUC score of all the models used in this study. From Fig. 7, it is observed that the proposed model outclass all the other models in terms of the mentioned performance metrics.

Figure 8 demonstrates the f1-measure and MCC-score of all the utilized classification models used in this study. Again our proposed model left behind all the other classification models in terms of f1-measure and MCC-score by conquering the f1-score of 0.97 and MCC-score of 0.93, respectively.

The ROC curves of all the models used in this study are shown in Fig. 9.

From Fig. 9, once again the highest performance in terms of ROC curve was observed for the proposed dual-feature fusion neural network model.

Performance of all the utilized classification models has been evaluated with the help of numerous performance measures as mentioned above. From the experimental results, it is obvious that the proposed model performed really well in terms of all performance measures. The second-best performance was observed for DenseNet, while the SVM classification model showed poor

performance in terms of all performance evaluation metrics as compared to the rest of the utilized models.

In short, the method based on the dual-feature fusion neural network model showed excellent performance and superiority in terms of all performance measures.

We selected 30% of athletes for experimental testing. All these athletes will receive normal sports training within a week. In order to make a fair comparison, all experiments were conducted in the same environment. From the above discussion and experimental results, the model proposed in this study has achieved the best accuracy, which is far better than the other 6 groups of methods, which also fully proves the effectiveness of the proposed model.

## 5 Conclusion

Sports injuries of high-level athletes have a significant impact on the performance and career of an athlete. These injuries restrict the improvement in an athlete's performance, as he/she may not be on the field for a longer period. Various techniques have been used in the past, but they have certain limitations. Hence, there is a need for an intelligent framework or a system that can accurately evaluate, predict and detect potential sports injury, and carry out injury prevention training. This study proposes a novel dual-feature fusion neural network model for athlete injury estimation. The proposed model solves the problem of feature loss caused by merging operations, which results in the degradation of classification accuracy. It uses  $1 \times 1$  convolution and hyperlink to form a dual-fusion structure to enhance effective discrimination. Multiple experiments have been performed using different models. Experimental result shows that the proposed model effectively identifies athletes' injury and gives more accurate prediction by attaining the classification accuracy of 97.00%. The performance of the proposed model was superior as compared to the other utilized models.

**Acknowledgements** This work was supported by Key R&D Projects in Shanxi Province. Project name: Exercise prescription for compulsory isolation of drug addicts based on data intelligence accurate recommendation system development. Item number: 201903D321039.

## Declarations

**Conflict of interest** The authors declare no conflict of interest.

## References

- Murphy DF, Connolly DAJ, Beynon B (2003) Risk factors for lower extremity injury: a review of the literature. *Br J Sports Med* 37(1):13–29
- Ba H (2020) Medical sports rehabilitation deep learning system of sports injury based on MRI image analysis. *J Med Imaging Health Informatics* 10(5):1091–1097
- Palmer D, Cooper DJ, Emery C, Batt ME, Engebretsen L, Scammell BE, Budgett R (2021) Self-reported sports injuries and later-life health status in 3357 retired Olympians from 131 countries: a cross-sectional survey among those competing in the games between London 1948 and PyeongChang 2018. *Br J Sports Med* 55(1):46–53
- Sillero-Quintana M, Gomez-Carmona PM, Fernández-Cuevas I (2021) Infrared thermography as a means of monitoring and preventing sports injuries. In: *Research anthology on business strategies, health factors, and ethical implications in sports and eSports*. IGI Global, pp 832–865
- Davis WA 3rd, Yagnik GP (2021) In-season management of acute and subacute sports foot injuries. *Foot Ankle Clin* 26(1):187–203
- Bolling C, Van Mechelen W, Pasman HR, Verhagen E (2018) Context matters: revisiting the first step of the 'sequence of prevention' of sports injuries. *Sports Med* 48(10):2227–2234
- Andreoli CV, Chiaromonte BC, Biruel E, de Castro Pochini A, Ejnisman B, Cohen M (2018). Epidemiology of sports injuries in basketball: integrative systematic review. *BMJ Open Sport & Exercise Med* 4(1).
- Chang PD, Wong TT, Rasiej MJ (2019) Deep learning for detection of complete anterior cruciate ligament tear. *J Digit Imaging* 32(6):980–986
- Ning X, Gong K, Li W, Zhang L, Bai X, Tian S (2020) Feature Refinement and Filter Network for Person Re-identification. *IEEE Trans Circuits Syst Video Technol*.
- Jan MA, Khan F, Mastorakis S, Adil M, Akbar A, Stergiou N (2021) LightIoT: Lightweight and secure communication for energy-efficient IoT in health informatics. *IEEE Trans Green Commun Netw*, pp 1–10.
- Ning X, Duan P, Li W, Zhang S (2020) Real-time 3D face alignment using an Encoder-Decoder Network with an efficient ddeconvolution layer. *IEEE Signal Process Lett* 27:1944–1948
- Liu Q (2021) Aerobics posture recognition based on neural network and sensors. *Neural Comput Applications*, pp 1–12.
- Ning X, Gong K, Li W, Zhang L (2020) JWSAA: Joint weak saliency and attention aware for person re-identification. *Neurocomputing*.
- Cai W, Liu B, Wei Z, Li M, Kan J (2021) TARDB-Net: triple-attention guided residual dense and BiLSTM networks for hyperspectral image classification. *Multimedia Tools Applications*, pp 1–22.
- Ning X, Wang Y, Tian W, Liu L, Cai W (2021) A biomimetic covering learning method based on principle of homology continuity. *ASP Trans Pattern Recogn Intell Syst* 1(1):9–16
- Liu Q, Cheng L, Jia AL, Liu C (2021) Deep reinforcement learning for communication flow control in wireless mesh networks. *IEEE Network* 35(2):112–119
- Liu R, Ning X, Cai W, Li G (2021) Multiscale dense cross-attention mechanism with covariance pooling for hyperspectral image scene classification. *Mobile Information Syst*.
- Jianming Zhang, Juan Sun, Jin Wang, Xiao-Guang Yue (2020) Visual object tracking based on residual network and cascaded correlation filters. *J Ambient Intell Humanized Comput*. <https://doi.org/10.1007/s12652-020-02572-0>.
- Ning X, Wang X, Xu S, Cai W, Zhang L, Yu L, Li W (2021) A review of research on co-training. *Concurrency and computation: practice and experience*, 2021.
- Li Y, Zhang H, Shen Q (2017) Spectral-spatial classification of hyperspectral imagery with 3D convolutional neural network. *Remote Sensing* 9(1):67

21. Krizhevsky A, Sutskever I, Hinton GE (2017) ImageNet classification with deep convolutional neural networks. *Commun ACM* 60(6):84–90
22. He K, Zhang X, Ren S, Sun J (2016) Deep residual learning for image recognition. In: *Proceedings of the IEEE conference on computer vision and pattern recognition* (pp. 770–778).
23. Huang G, Liu Z, Van Der Maaten L, Weinberger KQ (2017) Densely connected convolutional networks. In: *Proceedings of the IEEE conference on computer vision and pattern recognition*, pp 4700–4708.
24. Zhang C, Li G, Du S, Tan W, Gao F (2019) Three-dimensional densely connected convolutional network for hyperspectral remote sensing image classification. *J Appl Remote Sensing* 13(1):016519.

**Publisher's Note** Springer Nature remains neutral with regard to jurisdictional claims in published maps and institutional affiliations.