

Generation of ultrafast mid-infrared laser by DFG between two actively synchronized picosecond lasers in a MgO:PPLN crystal

H. Xuan · Y. Zou · S. Wang · H. Han · Z. Wang · Z. Wei

Received: 15 February 2012 / Published online: 24 May 2012
© Springer-Verlag 2012

Abstract We report the difference-frequency generation (DFG) of ultrafast mid-infrared laser radiation around 3 μm between two picosecond laser pulses with the center wavelengths of 800 nm and 1064 nm in a MgO:PPLN crystal at room temperature. The two laser pulses were generated from the actively synchronized picoseconds Ti:sapphire and Nd:YVO₄ oscillators. We measured the DFG wavelengths tunable from 3.19–3.29 μm and the output power is potential to be several mW. This experiment proves a possible roadmap for ultrafast mid- and far-infrared laser radiation generation and even for the THz radiation.

1 Introduction

Mid-infrared (mid-IR) laser radiation between 3 μm and 5 μm are in great demand for a variety of applications in many fields such as atmospheric communication, environmental sensing, spectroscopy of molecular vibrations, and biological research, etc. Although the solid-state laser has made rapid progress in recent years, the gain media directly to generate laser radiation in this wavelength range is still limited so far. Therefore, nonlinear optical frequency conversion is applied to generate the mid-IR radiation such as optical parametric oscillation (OPO), optical parametric amplification (OPA), and difference-frequency generation (DFG). Among all these methods, DFG is an effective and competitive technology. Recently, even few cycles mid-IR source has been demonstrated by DFG and OPA with pulse

energy of 3.8 μJ [1]. In particular, THz radiation is also realized by DFG along with cavity enhancement recently [2, 3].

Significant efforts have been dedicated to mid- or far-IR laser generation by DFG [1, 4–10]. In these experimental schemes, pump and signal lasers contain CW or Q-switched Nd:YAG lasers, external cavity diode laser, dye laser, Ti:sapphire oscillator or amplifier, and fiber laser, etc. More recently, a tunable mid-IR laser from 3.0 μm to 4.0 μm is obtained by DFG between a Yb-doped fiber laser and its Raman-shifted soliton [11]. On the other hand, the nonlinear crystals for DFG are mostly focusing on AgGaS₂, GaS, and periodically-poled crystals.

Constructing a stable and compact mid-IR ultrafast laser pulse source is still a major challenge now. Furthermore, many applications benefit from high repetition rate mid-IR laser source. However, in the above experiments, ultrafast mid-IR laser sources are often constructed from low repetition rate amplifiers, which is also in large size. With the development of active synchronization [12], stable synchronization between two independent ultrafast lasers have been realized [13], which will enable us to generate laser pulse at infrared range by DFG at a high repetition rate.

2 Experiment setup

In this paper, we demonstrate a room temperature tunable ultrafast mid-infrared laser system based on DFG between two synchronized ultrafast lasers tunable from 3.19 μm to 3.29 μm at 80 MHz. To our best knowledge, it is for the first time that ultrafast mid-IR laser radiation generated by DFG between two independent actively synchronized ultrafast oscillators.

H. Xuan · Y. Zou · S. Wang · H. Han · Z. Wang · Z. Wei (✉)
Beijing National Laboratory for Condensed Matter Physics
and Institute of Physics, Chinese Academy of Sciences, Beijing,
China
e-mail: zywei@iphy.ac.cn

2.1 Experiment setup of DFG by synchronized two picoseconds oscillators

Figure 1 shows the schematic layout for generating ultrafast infrared laser pulse by DFG. Laser radiation from a home-made Nd:YVO₄ laser at 1064 nm with output power of 1 W, is coupled onto a dichroic mirror M4 together with the 800 nm laser radiation from a commercial Ti:sapphire laser (Tsunami, Spectra Physics, Inc.) with output power of 1 W. The pulse duration of the two lasers are 15 ps and 60 ps, respectively.

One of the cavity mirrors of Nd:YVO₄ oscillator is mounted on a piece of piezoelectric transducer (PZT) which was controlled by a self-designed PLL electronics. The repetition rates are detected by two photo diodes, which convert the lights reflected by splitters P1 and P2 into electric signals, respectively. Two 100 MHz low-pass filters (F1, F2)

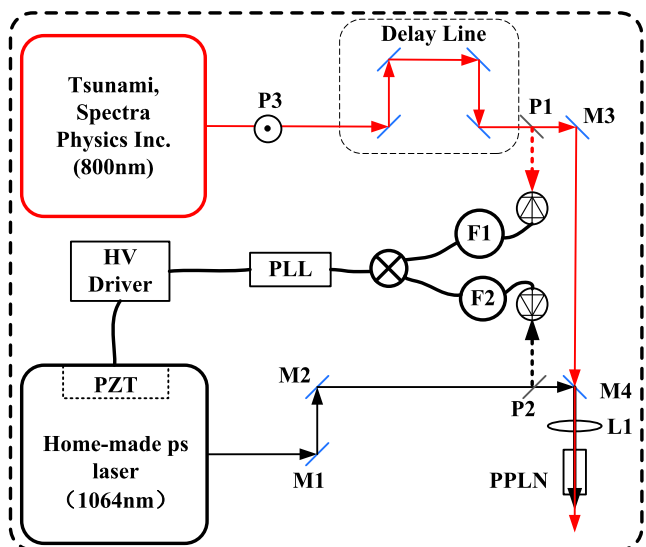
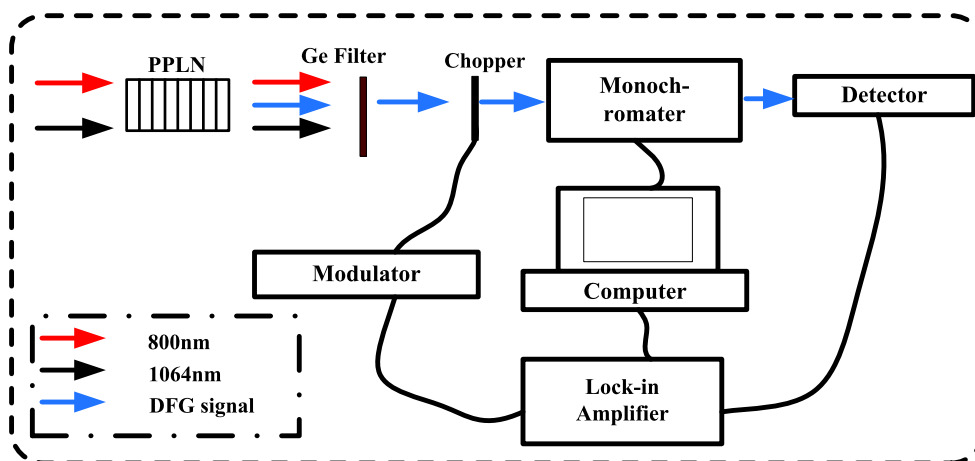

Fig. 1 Schematic layout for generating ultrafast mid-IR laser radiation by DFG (M1, M2: HR@1064 nm; M3: HR@800 nm; M4: HT@800 nm, HR@1064nm)

Fig. 2 Ultrafast mid-IR radiation detection scheme



and a mixer are used to obtain an error signal of phase. The PLL compares the phase of the fundamental frequencies of the two lasers. The synchronization is realized by changing the voltage of the PZT, being controlled with a high voltage amplifier to adjust the cavity length accurately. In other words, the repetition rate of Nd:YVO₄ fits that of Tsunami. P3 is a periscope and used to get a correct polarization of Ti:sapphire laser beam for the PPLN crystal. The delay line is used to optimize the overlapping in temporal domain. A 50-mm-focal-length convex lens (L1) focuses the two beams onto the MgO:PPLN crystal (5 × 3 × 1 mm³) that was poled with a domain period of 22.13 μm.

2.2 Detection scheme of mid-IR signal by DFG

The detection scheme of DFG is shown as Fig. 2. A piece of genium (2–4 μm) is used to filter the pump and signal lasers. Being modulated by a chopper, the DFG signal is input into a monochromator (Zolix, Omni-1, 150-DZ2) and detected by a HgCdTeZn infrared detector (Vigo System S.A., PCI-3TE-10.6). To increase the signal to noise ratio, a lock-in amplifier (SR830, Stanford) is connected to the infrared detector and to the modulator of chopper. Meanwhile, a signal from the monochromator is linked to the computer and the DFG spectrum is recorded by the computer software.

3 Experiment results and discussion

With fine alignment of the two laser beams, both in spatial and temporal domain, we obtained the infrared spectrum as shown in Fig. 3(b). By equation

$$\frac{1}{\lambda_p} - \frac{1}{\lambda_s} = \frac{1}{\lambda_i}, \tag{1}$$

where λ_p and λ_s is the wavelength of the pump and signal. In our experiment, we select 798 nm and 1064 nm as the pump and signal shown in Fig. 3(a), respectively. Hence, λ_i ,

Fig. 3 (a) The pump tuned at 798 nm and the signal at 1064 nm; (b) Measured idler spectrum with the central wavelength at 3192 nm

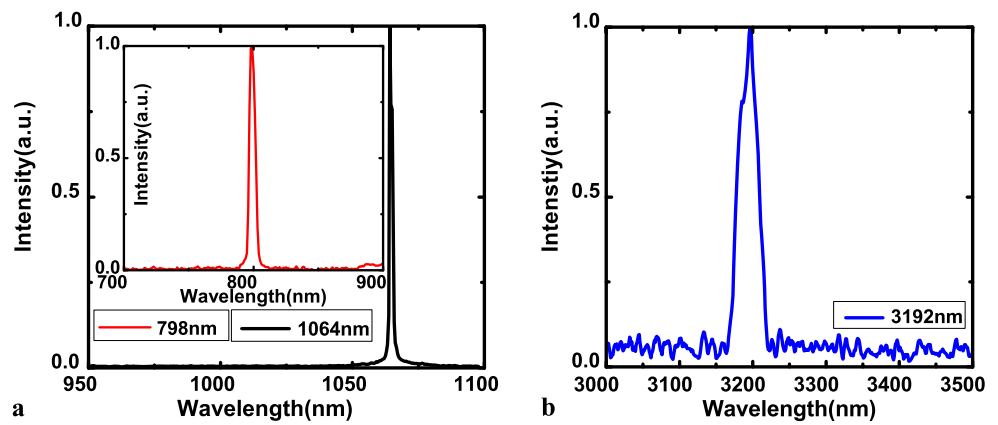

the wavelength of idler is at 3192 nm, corresponding to the central wavelength of the recorded spectrum.

3.1 Bandwidth of DFG wavelength

From the experiment results, the bandwidth of the DFG spectrum is wider than that of the pump and signal. Firstly, it is due to the resolution of the monochromator. Experimentally, on account of the weak intensity of the mid-IR laser, the input and output slits are opened wider to pass more idler power to the infrared detector, which causes the recorded spectrum to be wider.

The other reason is due to the groove of the grating inside the monochromator, which is 50 g/mm also leading to a lower resolution of the DFG spectrum. Moreover, the bandwidths of Ti:sapphire and Nd:YVO₄ laser are 1 nm and 0.5 nm, respectively. According to Eq. (1), the bandwidth of $\Delta\lambda_p$, $\Delta\lambda_s$, and $\Delta\lambda_i$ should satisfy the formula:

$$\frac{\Delta\lambda_p}{\lambda_p^2} - \frac{\Delta\lambda_s}{\lambda_s^2} = \frac{\Delta\lambda_i}{\lambda_i^2}, \tag{2}$$

from which we can infer that the bandwidth of DFG, $\Delta\lambda_i$, is about 11.7 nm. Comparing to the measured results, we think the difference comes from the spectrum modulation in PPLN. Although it is not strong enough because of the lower laser power, the SPM effect can also broaden the spectrum in this special case.

3.2 Timing jitter

During the experiment, the idler of DFG can run stable for a whole day. No change of the DFG system on the next day, we could get the DFG signal as soon as the PLL closed, which means the experimental setup works in good stability. To further evaluate the stability of the synchronization, we replaced the MgO:PPLN crystal by a BBO crystal with a thickness of 14 mm to measure the cross-correlation trace. By readjusting the delay line to optimize the SFG from

the BBO crystal, we obtain a Gaussian type trace of cross-correlation as Fig. 4(a). Fitting the measured data with Gaussian shape (in red), the FWHM of the cross-correlation is 20 ps. The standard deviation of the fluctuation of half maximum intensity of SFG at a fixed delay is shown as Fig. 4(b), which is less than 0.1, implying that the RMS timing jitter between two lasers is no more than 1 ps. Although these results are not better than those in previous results [12, 13], in which a BBO crystal is used for optical feedback to reduce timing jitter along with precise PLLs at the same time, it is simple with only one PLL and enough for our mid-IR laser generation.

3.3 Poled period of MgO:PPLN crystal

According to Eq. (1) and two different approximations of the Sellmeier equation in [14, 15], the poling periods of MgO:PPLN are calculated as 21.78 μm and 22.79 μm , respectively. In detail, the former deduction of Sellmeier equation has a temperature parameter of 45 °C, while the latter one does not. Considering the error of the above two approximates and the available commercial crystals, the period of the crystal we used is 22.13 μm (HCP Corp.) with the working temperature at 45 °C for phase matching.

However, experimentally, we have the crystal just worked at room temperature of 21 °C according the angle tuning curve for phase matching in [14] and observed the mid-IR laser radiation generation. Although the period 22.13 μm and the working temperature slightly mismatches the calculation results, it makes sense that the crystal works at room temperature for simple and practical applications.

3.4 Ultrafast mid-IR laser power

We measured the average power of the mid-IR radiation that is about 10 μW (Rkp573, Laser Probe, Inc.) when the idler is tuned at 3192 nm, with a same power level referring to [5]. Both the beam size of the pump and signal laser are 2 mm

Fig. 4 (a) Measured and fitted cross-correlation curves shows the FWHM is about 20 ps; (b) fluctuation of half maximum intensity of SFG at a fixed delay

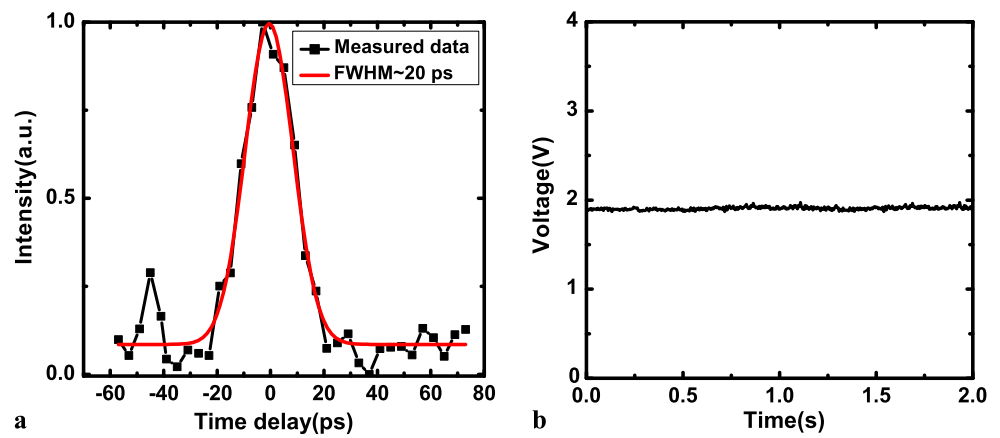
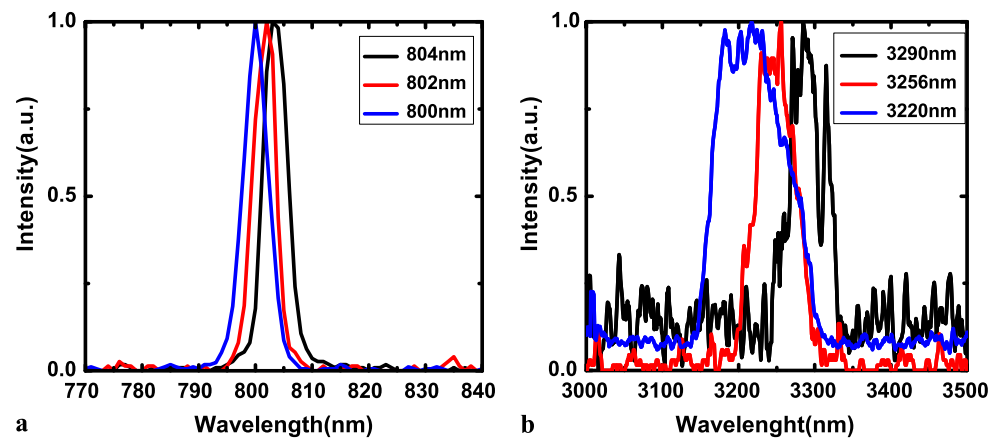

Fig. 5 (a) Tunable pump wavelengths at 800 nm, 802 nm, and 804 nm; (b) Tunable idler wavelengths with the center at 3220 nm, 3256 nm, and 3290 nm corresponding to the pump



in diameter, and they are focused to 8 μm and 10 μm by L1, respectively.

Consequently, we calculated the confocal parameter, $b = 2\pi\omega_0^2 n / (\lambda_p + \lambda_s) = 0.67$ mm, and thus $\xi = L/b = 7.42$ [6], indicating that estimated Boyd and Kleinman focusing parameter of $h(\mu, \xi) = 0.2$, according to the function curve in [16]. Applying $P_p = P_s = 1$ W, $h(\mu, \xi) = 0.2$, and $d_{\text{eff}} = 15$ pm/V [4] to the DFG power conversion equation [4, 16] of

$$P_i = \frac{4\omega_i^2 k_s k_p d_{\text{eff}}}{\pi \epsilon_0 (k_s + k_p) n_i n_s n_p} h(\mu, \xi) L P_s P_p, \quad (3)$$

the mid-IR laser power is estimated as 0.14 mW, which means the DFG power could be further optimized. Moreover, our homemade 1064 nm mode-locking laser could run at the average power of 3 W. Hence, if we carefully design the crystal length with larger d_{eff} and optimize the focusing parameters, which could reach its maximum of 0.3, the output power of the mid-IR laser has potential to be improved to the mW level [1].

3.5 Tunability of the mid-IR wavelength

We further observed the DFG wavelength by carefully tuning the wavelength of Ti:sapphire laser from 800 nm to

804 nm. The Ti:sapphire and the DFG laser spectra are shown in Figs. 5(a) and 5(b), respectively. It shows the DFG signal is tunable from 3.2 μm to 3.29 μm which is well agreement with the calculated results.

4 Summary

In summary, we demonstrate mid-IR laser radiation generated by DFG between two actively synchronized picosecond lasers in a MgO:PPLN at 80 MHz for the first time, to our best knowledge. The mid-IR laser is tunable from 3.19 μm to 3.29 μm . The cross-correlation is 20 ps and the output power is about 10 μW at 3.19 μm , which is possible to be several mW.

This ultrafast mid-IR laser source is stable, compact, and tunable at a high repetition rate. Moreover, what is the most important is that this approach demonstrates that we can use two actively synchronized independent ultrafast lasers to implement an efficient, compact mid-IR, or THz source through further optimization.

Acknowledgements The authors thank the helpful discussion with Professors Xinkui He and Hao Teng. This work is partly supported by the Knowledge Innovation Program of Chinese Academy of Sciences

under the grant KJCX2-YW-N48 and Natural Science Foundation of China under grants 60808007 and 10874237.

References

1. O. Chalus, A. Thai, P.K. Bates, J. Biegert, *Opt. Lett.* **35**, 3204 (2010)
2. E.B. Petersen, W. Shi, D.T. Nguyen, Z. Yao, J. Zong, A. Chavez-Pirson, N. Peyghambarian, *Opt. Lett.* **35**, 2170 (2010)
3. E.B. Petersen, W. Shi, A. Chavez-Pirson, N. Peyghambarian, A.T. Cooney, *Appl. Phys. Lett.* **98**, 121119 (2011)
4. L. Goldberg, W.K. Burns, R.W. McElhanon, *Opt. Lett.* **20**, 1280 (1995)
5. R.A. Kaindl, D.C. Smith, M. Joschko, M.P. Hasselbeck, M. Woerner, T. Elsaesser, *Opt. Lett.* **23**, 861 (1998)
6. L. Goldberg, W.K. Burns, R.W. McElhanon, *Appl. Phys. Lett.* **67**, 2910 (1995)
7. I. Galli, S. Bartalini, S. Borri, P. Cancio, G. Giusfredi, D. Mazzotti, P. De Natale, *Opt. Lett.* **35**, 3616 (2010)
8. F. Seifert, V. Petrov, M. Woerner, *Opt. Lett.* **19**, 2009 (1994)
9. D.G. Winters, P. Schlup, R.A. Bartels, *Opt. Lett.* **35**, 2179 (2010)
10. J. Chang, Q. Mao, S. Feng, X. Gao, C. Xu, *Opt. Lett.* **15**, 3486 (2010)
11. T.W. Neely, T.A. Johnson, S.A. Diddams, *Opt. Lett.* **36**, 4020 (2011)
12. L.-S. Ma, R.K. Shelton, H.C. Kapteyn, M.M. Murnane, J. Ye, *Phys. Rev. A* **64**, 021802 (2001)
13. H. Zhao, P. Wang, J. Zhu, Q. Du, Z. Wei, *J. Opt. Soc. Am. A* **25**, B39 (2008)
14. D.H. Jundt, *Opt. Lett.* **22**, 1553 (1997)
15. D.E. Zelmon, D.L. Small, D. Jundt, *J. Opt. Soc. Am. B* **14**, 3319 (1997)
16. P. Canarelli, Z. Benko, R. Curl, F.K. Tittel, *J. Opt. Soc. Am. B* **9**, 197 (1992)