



Correction: Enhancing biocompatibility of magnesium implants: nanocomposite coating for corrosion resistance and bioactivity

Negar Mehri Ghahfarokhi¹ · Behrooz Shayegh Boroujeny¹ · Amin Hakimizad² · Fatemeh Forouzandeh³ · Latifeh Karimzadeh Bardeei⁴ · Hassan Nazari⁵ · Narges Ghafouri Varnosfaderani⁶ · Delara Aarabisamani⁷ · Ali Doostmohammadi⁸

© The Author(s), under exclusive licence to Springer-Verlag GmbH Germany, part of Springer Nature 2024

Correction to: Applied Physics A (2024) 130:693
<https://doi.org/10.1007/s00339-024-07820-0>

$$R_P = \frac{\beta_a \beta_c}{2.3031 i_{corr} (\beta_a + \beta_c)}$$

In the affiliation 8 for Ali Doostmohammadi, University name (York University) was missing.

The original article has been corrected.

The wrong figure appeared as Fig. 5.; the figure should have appeared as shown below

Equation (1) in page 9 is not in its correct form.; the equation should have appeared as shown below.

The online version of the original article can be found at <https://doi.org/10.1007/s00339-024-07820-0>.

✉ Ali Doostmohammadi
Doost@yorku.ca

- ¹ Materials Department, Engineering Faculty, Shahrekord University, Shahrekord 88186-34141, Iran
- ² Yekta Mobaddel Pars Co., Science and Technology Campus, Yazd University, Yazd 89158-18411, Iran
- ³ Tissue Engineering and Applied Cell Sciences Division, Department of Anatomical Sciences, Faculty of Medical Sciences, Tarbiat Modares University, Tehran, Iran
- ⁴ Department of Animal Biology, Faculty of Biological Sciences, Kharazmi University, Tehran 15719-14911, Iran
- ⁵ Research Institute of Animal Embryo Technology, Shahrekord University, Shahrekord, Iran
- ⁶ Department of Materials Engineering, Isfahan University of Technology, Isfahan 84156-83111, Iran
- ⁷ Department of Mechanical Automotive and Materials Engineering, University of Windsor, Windsor, ON N9B3P4, Canada
- ⁸ Department of Mechanical Engineering, York University, Toronto, ON M3J 1P3, Canada

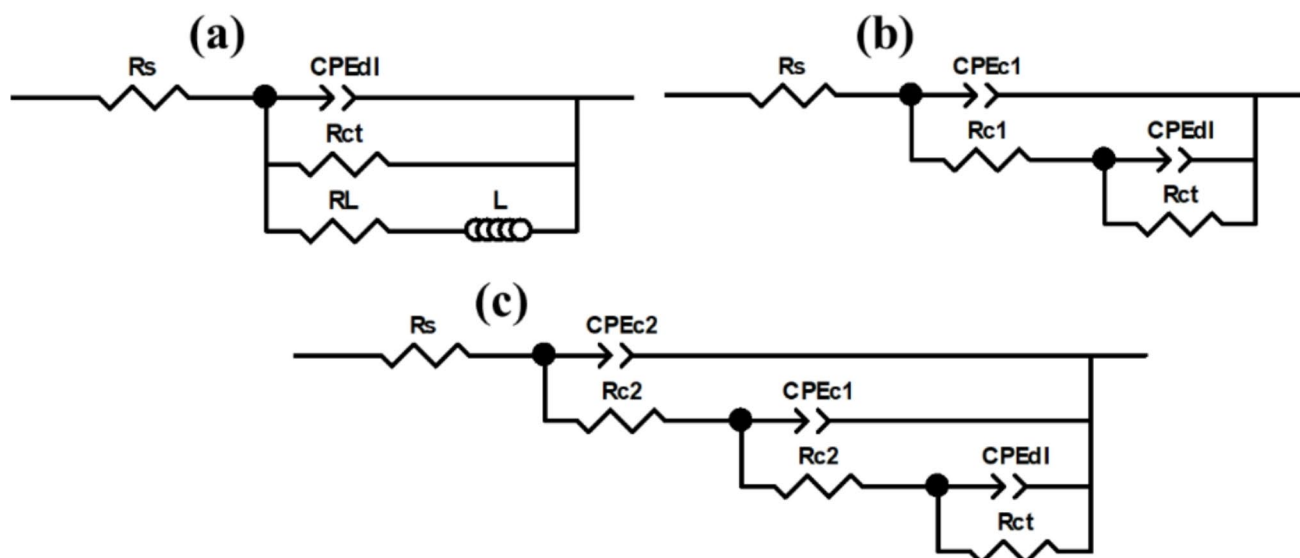

Fig. 5 Electrical equivalent circuits used to fit electrochemical impedance data of (a) the AZ91 alloy substrate, (b) the PEO-coated sample, and (c) the PEO/PDMS-nBG-coated sample

Publisher's note Springer Nature remains neutral with regard to jurisdictional claims in published maps and institutional affiliations.