



# Initiating predictive maintenance for a conveyor motor in a bottling plant using industry 4.0 concepts

Kahiomba Sonia Kiangala<sup>1</sup> · Zenghui Wang<sup>1</sup>

Received: 8 March 2018 / Accepted: 26 April 2018 / Published online: 24 May 2018  
© Springer-Verlag London Ltd., part of Springer Nature 2018

## Abstract

For the past recent years, Industry 4.0 (I40) also known as smart manufacturing, together with advanced manufacturing techniques, has been introduced in the industrial manufacturing sector to improve and stabilize processes. Nevertheless, practical applications of these advanced technologies are still in their early stages resulting in slow adoption of the I40 concepts, especially for small- to medium-scale enterprises (SMEs). This paper proposes the design of an experimental method to integrate the practical use of Industry 4.0 in a small bottling plant; especially by detecting early faults or threats in conveyor motors and generating accordingly a predictive maintenance schedule. Using advanced programming functions of a Siemens S7-1200 programmable logic controller (PLC) controlling the bottling plant, vibration speed data is monitored through vibration sensors mounted on the motor and an efficient predictive maintenance plan is generated. The running PLC communicates with a supervisory control and data acquisition (SCADA) graphical user interface (GUI) which instantaneously displays maintenance schedules and allows, whenever required, flexible configuration of new maintenance rules. This paper also proposes a decentralized monitoring system from which vibration speed states can be monitored on a cloud-based report accessible via the Internet; the decentralized monitoring system also sends instant email notifications to the intended supervisor for every maintenance schedule generated. By its results, this research shows different possibilities of the practical use of Industry 4.0 basic concepts to better manufacturing operations within SMEs and opens a path for more improvement in this sector.

**Keywords** Industry 4.0 · Predictive maintenance · Motor vibration speed · Siemens S7-1200 PLC · Email notification · SCADA · Cloud-based dashboard report

## 1 Introduction

In manufactories and plants, unplanned equipment failure usually results in longer downtime and production loss. The role of the engineering team in the plant is to prevent such faults by detecting earlier any possible threats to the system and take proper action before the situations become chaotic; in other words, schedule maintenance of the affected devices. Some of these threats are invisible to the human eye and very difficult to detect without specialized

tools. The introduction of technology that allows the condition or “health” of machinery to be checked with the minimum of or no intrusion is one of the most cost-effective maintenance tools currently available [1]. The action of detecting faults or threats in a device before they actually occur and implementing repairs on it to reduce failure is called “predictive maintenance.” Predictive maintenance is a set of activities that detect changes in the physical condition of equipment (signs of failure) in order to carry out the appropriate maintenance work for maximizing the service life of equipment without increasing the risk of failure [2]. To be able to achieve predictive maintenance, intelligent devices like sensors need to be embedded in different critical machines of the plant to collect data that is analyzed and interpreted. With the advent of the so-called Industry 4.0 (I40), more intelligence and value are being added to the predictive maintenance of a system to make this task more efficient. Below are some of the values which Industry 4.0 brings into the predictive maintenance concept:

---

✉ Zenghui Wang  
wangzengh@gmail.com

Kahiomba Sonia Kiangala  
60988568@mylife.unisa.ac.za

<sup>1</sup> Department of Electrical and Mining Engineering, University of South Africa, Johannesburg 1710, South Africa

- **Real-time condition monitoring:** Industry 4.0 software can help to create the information availability and processing required. Machine and sensor data is recorded and displayed in real time, providing the basis for real-time condition monitoring. Data visualization is not restricted to the control station. The same solution can be available everywhere—from big screens to tablet computers and smartphones, on premises, and in the cloud. And it can be accessed by everyone—from those in charge of machine settings to a variety of experts [3]. In this paper, real-time condition monitoring is performed by the programmable logic controller (PLC) and its supervisory control and data acquisition (SCADA).
- **Flexible evaluation and analysis options:** Industry 4.0 software is designed in a flexible manner using highly customized rules and analyses that allow production planners, process experts, or even the maintenance technicians to configure on their own without the need for complicated IT know-how. The software adapts to the expert's needs. As such, Industry 4.0 is ushering in a paradigm shift. The software is designed for human needs and not, as before, programmed with just the machine in mind. This means the maintenance technician can create rules such that defined machine parameters trigger notice of upcoming maintenance. And this maintenance is performed only when it is actually needed. Conversely, of course, limit values and rules can also be set such that unscheduled machine stoppages are immediately displayed and notifications sent to the relevant people [3]. Technicians, production planners, and experts will sit together and decide on different rules that will define the predictive maintenance. This rule will be modeled in a computer language, in our case in a PLC language, and loaded into the system. This point is covered in Section 3.
- **Targeted notification of experts:** As soon as the software has identified an upcoming maintenance task based on the pre-set parameters, the information must be forwarded quickly and specifically to the right team member via a digital ticket. To give an example, this means that an available worker with the right qualifications for maintaining the laser machine in hall 3 receives a ticket in their account and on their phone telling them to carry out the maintenance [3]. It is one thing to detect a threat in a system and it is another one to take action against that threat. Once predictive maintenance has been scheduled for the system, it has to be addressed to the intended person as soon as possible for action to be taken before actual faults occur. In this paper, we will also make use of this aspect to send an email notification through the Internet directly to the intended maintenance officer from a python script virtually communicating with the Siemens S7-200 PLC.

In a bottling plant, almost all machines are subject to vibrations. For example, machine unbalance, misalignment, and resonances can cause machines to vibrate above an acceptable level. Vibration analysis is proven to be an important criterion for fault diagnosis in manufacturing processes and maintenance scheduling for various manufacturing equipment [4]. A rise in vibrations is detrimental to machine health. This results in unexpected machine failure and reduced availability [5]. The conveyor belt driving bottles into the bottling process, through its motor, is one of the most important components of the bottling plant. Our paper will focus in developing a predictive maintenance schedule for the motor. An intelligent vibration sensor will be mounted into the motor to read vibration speeds and transmit them to the PLC, which is based on the modeled maintenance rule loaded will notify directly the maintenance expert via email, every time a maintenance schedule is announced, all this done through the benefits carried out by the current trend of automation, “the industry 4.0.”

This paper is divided into five main sections. Section 2 presents a brief review of predictive maintenance of manufacturing process. The modeling of the predictive maintenance rule based on the motor vibration velocity is explained in Section 3. Section 4 presents in detail the structure and control system design of our experimental predictive maintenance schedule for the bottling plant; the programming functions used in the Siemens S7-1200 PLC, as well as the configuration of the python script system to notify the maintenance officer. And this section also displays the results of the predictive maintenance schedule. Finally, the conclusion is given in Section 5.

## 2 Literature review

### 2.1 Smart manufacturing

The industrial sector is currently going through its fourth revolution; commonly known as Industry 4.0 (I40), smart or intelligent manufacturing. The first industrial revolution brought the mechanization of production, the second industrial revolution was about mass production, and the third industrial revolution means the digitization (electronic component computer and IT). I40 enables suppliers and manufacturers to leverage new technological concepts like cyber-physical systems (CPS), Internet of Things (IoT), and cloud computing (CC). New or enhanced products and services can be created, cost can be reduced, and productivity can be increased [6]. Tim Niesen et al. [7] mention that I40 is characterized by a progressing integration of ICT into manufacturing systems. Ref. [8] defines manufacturing as the process of transforming (raw) materials and energy, by means of workers and machinery, into products that address manufacturing requirements from stakeholders. On the other hand, smart or intelligent manufacturing refers to any manufacturing processes which

involve a degree of computational intelligence. This can be via the use of embedded sensors as in the case of IoT technologies [9], and cover the use of analytical techniques on historical process data to provide knowledge discovery and support decision-making within manufacturing systems [10, 11] or, ultimately, the development and implementation of full cyber-physical-systems [12], a synthesis of physical and digital technologies across the entire manufacturing system; and necessary associated technologies and frameworks [13]. [14] further summarizes smart manufacturing as any manufacturing system having one or a combination of the following characteristics: (1) digitization of manufacturing enterprises, (2) connected devices and distributed intelligence, (3) collaborative supply chain, (4) integrated and optimal decision making, and (5) sensors and big data analytics. While the industrial automation sector currently offers this advanced manufacturing scheme for improvement of industrial processes, many small- to medium-scale enterprises (SMEs) are still under the first, second, or third industrial revolution regarding this new concept as reserved to big industrial players.

## 2.2 The use of industry 4.0 in SMEs

Various studies have shown that most SMEs have a common perception that advanced automation techniques, specialized software like ERP, is best suited for large-scale industries due to high cost of ownership, complexity of implementation, and subsequent maintenance cost commonly known as “Big White Elephant” [15]. They therefore prefer holding on to old and sometimes archaic production methods in their everyday processes hoping to sustain production cost.

It was later proven that this lethargy in adopting current trends of automation is one of the main reasons why most SMEs are subject to low growth, high failure rates, and loss of production in the long term. Ref. [16] says that while technology is essential for growth of a company, it does come at a price, which is sometimes not affordable for an SME. While many options become unattractive because of the heavy investments they need, thus preventing small start-ups from entering, many start-ups find themselves lagging behind since they cannot have access to cutting edge technology, leaving them strategically exposed. The reality is that few companies have the necessary systems and capital in place to make leaps such as these in their operational processes and find themselves presented with substantial barriers with respect to access. Due to the vast scope of the technologies and methodologies and substantial costs involved and lack of understanding and competence with advanced manufacturing techniques at the employee level [17]. As per ref. [18], limited capital availability and lack of expertise are the main factors affecting modernization and expansion plans for an SME. Since the initial years of business do not produce enough cash flows, the available cash is used up in operating activities, and there

is shortage of funds for modernization and expansion. I40, the current trend of automation, is facing the same lethargy within SMEs. This is also caused by the lack of practical application of the new concept still on its early stages [38]. To remain competitive in a continuously growing market, the challenges of any industrial enterprise is to enhance product quality, reduce cost, and improve on-time delivery. Advanced automation techniques, new strategies, and upgrade trend of automation are developed to help companies fight this challenge and satisfy customers’ demand.

## 2.3 Predictive maintenance concept in manufacturing processes

Over recent years, about 30% [19] of the industrial equipment does not benefit from predictive maintenance techniques. Instead, periodic maintenance is used in order to detect any anomalies or malfunctions in the components of their systems. Such maintenance is usually done visually and physically placed on the machine. In order to clearly discern between a periodical and predictive maintenance, it has been shown that no problems were found in 70% [20] of the periodic revisions, while the percentages have reached up to 90% [21] when using predictive maintenance techniques. This suggests that the latter method can increase the maintenance efficiency, and therefore, it can reduce the amount of failures in industrial systems.

Although the maintenance based on periodic revisions is the most extended and used method, these techniques are being increasingly classified as constituting defective and unreliable methods [21]. After conducting a study with identical systems that were tested under identical conditions [19], it has been shown that the time until a failure occurs in the system is very different from one system to another. The maintenance that is based upon periodic revisions is thus ineffective, because it is very difficult to know when a component of an industrial process is going to fail based on a fixed period of time. The evolution of technology has made predictive maintenance techniques evolve too. The use of wireless sensors and the posterior use of supervisory control and data acquisition (SCADA) systems have provided companies with new ways of collecting information about the performances of their industrial machines.

Official figures from the late 1980s indicated that companies with an effective condition monitoring (CM) program were saving 25% on maintenance spend [1]. Condition-based maintenance techniques have been developed to allow scheduling maintenance actions based on machine’s condition measured without the interruption of the normal machine operations. In fact, condition monitoring is a decision-making strategy that allows real-time diagnosis of occurring failures and prognosis of future asset and machines/equipment health by continuous observation of the system and its components’ condition [6]. It is strongly related to the concept of prognostic and health monitoring (PHM) which has been initially

introduced in the medical field for disease and epidemiology prediction, but has been widely applied in manufacturing context [22]. Most failures do not occur instantaneously, and usually, there are some kind of degradation process or symptoms from normal states to failures. Therefore, the actual conditions and their trends should be assessed and predicted during the degradation process, and appropriate maintenance actions should be taken before breakdown. This is the main target of the predictive maintenance [23]. Predictive maintenance utilizes actual operating condition of equipment, material, and systems to optimize manufacturing operation. Standard predictive maintenance management program utilizes a combination of most cost-effective tools (e.g., vibration monitoring, process parameter monitoring, thermography, tribology, visual inspection) to obtain the actual operating conditions of critical plant systems. These actual manufacturing data are used to schedule all maintenance activities on an as-needed basis. Utilizing predictive maintenance in maintenance management program improves the ability to optimize the availability of process machinery and greatly reduces the cost of maintenance and improves production quality [24].

Predictive maintenance can be disaggregated into two specific sub-categories [25]:

- Statistical-based predictive maintenance. The information generated from all stoppages facilitates development of statistical models for predicting failure and thus enables the developing of a preventive maintenance policy.
- Condition-based predictive maintenance. Condition-based monitoring is related to the examination of wear processes in mechanical components. The wear process is preceded by changes in the machine's behavior although this does not cause sudden mechanical failure.

One of the most cost-effective maintenance techniques is condition-based maintenance. Condition-based maintenance in a plant management program provides the ability to optimize the availability of process machinery and greatly reduce the cost of maintenance. Major improvements can be achieved in: maintenance costs, unscheduled machine failures, repair downtime, spare parts inventory, and both direct and indirect overtime premiums [26]. Condition-based maintenance techniques provide an assessment of the system's condition, based on data collected from the system by continuous monitoring. The goal is to determine the required maintenance plan prior to any predicted failure. Therefore, the maintenance strategies aim to minimize the cost by improvement of the operational safety and reduce the severity and number of in-service system failures. Accordingly to the ISO 13381-1:2004 standard, the activities start with monitoring, followed by diagnostic, prediction, and posterior actions [27].

As per [28], one of the biggest issues in obtaining manufacturing data is the way of collecting and processing data

from the field level of hierarchical control. All these data serves as a basis for predictive maintenance, failure analysis, or decision support at various hierarchical control levels. The field-level data are usually aggregated into data more suitable for particular decision support task. One of the main requirements for effective realization of predictive maintenance is sufficient amount of data from all parts of manufacturing process. It is also the main drawbacks of predictive maintenance implementation in manufacturing. The more amounts of data ensures higher accuracy of prediction for maintenance interval for machines, materials, tools, and products or any other significant parts in the manufacturing process [29]. Thanks to the predictive capabilities offered by the emerging smart data analytics, data-driven approaches for condition monitoring are becoming widely used for early detection of anomalies on production machines [30]. It is also very important to note that predictive maintenance does not rely only on industrial or average lifetime statistics (i.e., mean time to failure (MTTF)) to schedule maintenance activities, but uses direct monitoring of the mechanical condition, system efficiency, and other indicators to determine the actual MTTF or loss of efficiency for each machine, material, product, or system in the plant. Implementation of a comprehensive predictive maintenance management can provide real data on the actual mechanical condition of each machine and operating efficiency of each process. The data provides the maintenance manager with actual data for scheduling maintenance activities [24]. J. Zhou developed a system that uses intelligent prediction and monitoring system for equipment failure prediction to support equipment maintenance [31]. This system used three platforms: embedded controller platform connected to field devices to collect data, intelligent predictive engine (IPE) that is the brain of operations and a remote platform used for monitoring.

Jemielniak summarized the most commonly used sensors and signal processing techniques in the tool CM. Many type of sensors such as acoustic emission, vibration, and optical sensors for measuring cutting forces components such as power, torque, displacement, and strain of tools were the most commonly used instruments in tool CM system for their versatile adjustment in both the existing and in new machines. Integrity and stiffness remains unaffected with the use of these sensors. Among many advanced signal analysis techniques, the filtering (low-pass, high-pass, and band-pass), averaging and RMS-based signal processing techniques were found to be most effective. It was concluded that one sensor-one tool/process approach was dominant in comparison to other commercially available systems. It was recommended to use two different sensors for one process in multiple detection capability system [32]. Yang et al. proposed and validated a new wavelet-based adaptive filter for CM of wind turbines. Conventionally, vibration measurement and lubrication oil analysis were used as CM systems in wind turbines. However, both these methods suffered from some drawbacks

as the former method required high hardware costs and the latter could not detect electrical abnormalities in the turbine generator and electrical system. Power energy used by the wind turbine was used as indicator of wind turbine condition as wavelet-based adaptive filter extracts the power energy at prescribed fault-related frequencies with both varying and constant rotational speeds. Experimental validation of the proposed technique was done on a wind turbine test rig by using both synchronous and induction generators as exemplars [33]. T. Borgi proposed a method that provides insights on predictive maintenance of industrial robots using data analysis of robot's power measurements [30]. They collected and analyzed few important data: robot electrical power, set of position coordinates, etc., on robot operation and generated a correlation between them. Another interesting strategy was proposed by C. Gu [34] in which the product quality control is integrated into predictive maintenance decision-making. First, the key process variables that characterize equipment wear are identified and integrated into the modeling of the equipment failure rate. Second, quality deviation that characterizes product quality level is defined based on co-effect between manufacturing system component reliability and product quality (i.e., Q-R chain). Third, the optimal maintenance strategy is obtained by optimizing the quality cost, maintenance cost, and interruption cost simultaneously.

This brief review on predictive maintenance in the manufacturing shows how important and advantageous this concept is in the industrial sector. A proper implementation of predictive maintenance reduces machine failures and downtime of the overall system. The design of predictive maintenance strategies strongly depends on machine data that needs to be, collected, analyzed, and interpreted. Based on the application in question, various tools are being used for this purpose, sometimes in combination with controllers to generate intelligent predictive maintenance methods. As mentioned in ref. [3], the current trend of automation, Industry 4.0, introduces the use of solutions that can provide optimum support for predictive maintenance. These solutions focused on real-time condition monitoring, flexible evaluation, and analysis options as well as targeted notification of experts. Our paper uses the three elements highlighted by the I40 in order to develop a strategy for the predictive maintenance of a conveyor or motor in a small bottling plant.

### 3 Motor vibration velocity threshold limits for predictive maintenance: theoretical modeling

As per Colin Sanders [1], the simple form of vibration is a single frequency system as shown in Fig. 1.

The velocity is the first derivative of displacement as a function of time; it is the rate of change in displacement (the

speed of the vibration). Based on Fig. 1, the displacement is equal to the amplitude of the vibration. The displacement or amplitude of a vibration is measured in inches, mils, micrometers, or millimeters.

The velocity or speed of vibration will therefore be measured in inches/s or mm/s.

The acceleration is the second derivative of displacement; it is the rate of change of velocity [35]. The relationship between sinusoidal velocity, displacement, and acceleration is shown in Fig. 2.

In this paper, we will only focus at the vibration velocity of the motor to determine predictive maintenance. As mentioned in the previous section, according to ISO 10816, there is an acceptable limit of vibration a motor should not exceed when operating. Figure 3 below shows a trend of machine vibration as per ISO 10816. When constantly exposed to undesired vibration, the motor lifespan is reduced and the chance of failures becomes high. One of the aims of our paper is to detect in advance all possible impairment due to motor vibration and schedule proper maintenance before failures occur. This is called predictive maintenance.

The size of the motor driving the conveyor will impact alarm and warning limits to the system. We will refer to Table 1 below to select our alarms and warning thresholds that will be later on programmed in the PLC.

Table 1 shows different vibration severity levels as described by ISO IS2372: good (displayed in green), satisfactory (displayed in yellow), unsatisfactory (displayed in orange), and unacceptable (displayed in red) The different classes on the table are divided as follows:

Class I: small-sized machines (from 0 to 15 kW)

Class II: medium-sized machines (from 15 to 75 kW)

Class III: large-sized machines (powered > 75 kW) mounted on "Rigid Support" structures and foundations

Class IV: large-sized machines (powered > 75 kW) mounted on "Flexible Support" structures

There are many other classifications for vibration severity criteria depending on applications and motors' sizes. In ref. [36], one of those criteria is used for vibration analyses.

To make operators' life easier, calculations and conditions to initiate the predictive maintenance of the conveyor motor is done in the background (in the PLC program). The only action that will be required from the operator is the selection on the SCADA system of the motor size range that will map it to the corresponding predictive maintenance rule.

Depending on one application to another, there are several types of safety, health criteria, or classes that a system should respect to function properly. Table 1 is an example of one of them. The RMS vibration speed on Table 1 is read from a vibration sensor that gets mounted on the motor fin. The other side of the sensor is then connected to an intelligent controller

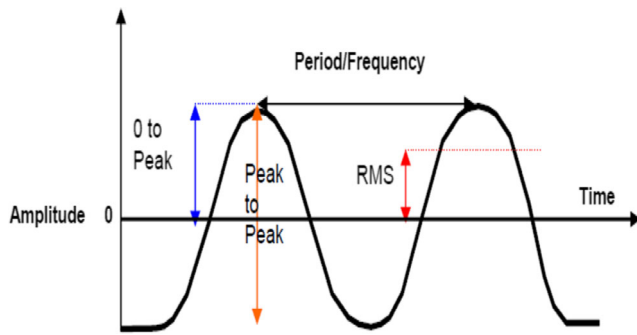

**Fig. 1** Vibration as a sine wave—Colin Sanders, “A Guide to Vibration Analysis and Associated Techniques in Condition Monitoring”, DAK Consulting

(in our paper to a Siemens S7-1200 PLC) or any other device that will convert the vibration speed into understandable digits (Figs. 4 and 5):

Let us assume the vibration criteria of a system with  $n$  number of classes, divided in  $b$  ranges for health statuses of a system:

- $b_1-b_2$  = healthy status
- $b_2-b_3$  = satisfactory status
- $b_3-b_4$  = intermediate status\_1
- $b_4-b_5$  = intermediate status\_2
- $b_s-b_m$  = unsatisfactory status
- $b_m-b_n$  = unacceptable status

Looking at the  $b$  ranges above as well as those on Table 1, it is very noticeable that the end of one range is the beginning of another; in other words, two health ranges share a border. In math, this will be explained as follows:

$$(b_1-b_2) \cap (b_2-b_3) = \{b_2\}, (b_2-b_3) \cap (b_3-b_4) = \{b_3\}, \dots, (b_s-b_m) \cap (b_m-b_n) = \{b_m\}$$

For this paper, we use the vibration criteria on Table 1 to program the predictive maintenance rule as follows:

The number of class is equal to 4 and the number of health ranges is also equal to 4:

- Range  $X_1-X_2$  → Healthy status
- Range  $X_3-X_4$  → Satisfactory
- Range  $X_5-X_6$  → Unsatisfactory
- Range  $X_7-X_8$  → Unacceptable

The vibration velocity of the motor read from the vibration sensor by the PLC at a time  $t$  is equal to  $V(t)$ :

Case 1:

If  $V(t) = V(X_7-X_8)$   
 → Initiate reactive maintenance with immediate stop.

Case 2

If  $V(t) = V(X_5-X_6)$   
 → Initiate predictive maintenance on next machine stop.

Case 3:

If  $V(t) = V(X_3-X_4)$   
 →  $V(\text{temp}) = \sum_{t \in N} V[X_3-X_4](t)$ ; with  $t$  time elapsed every hour.

If  $V(\text{temp}) = \{V(X_5 - X_6) \cup V(X_7 - X_8)\}$ .  
 → Initiate predictive maintenance on next machine stop.  
 The three cases above can be explained as follows:

Case 1 is not considered as a preventive maintenance rule because the range of velocity obtained is within the unacceptable range and requires immediate attention for safety of the whole system. It is therefore called reactive maintenance. Case 1 is also considered as an alarm of first degree. Case 2, if the motor vibration velocity obtained at a specific time falls within unsatisfactory range, the system will call for a predictive maintenance at the next machine stop. The motor is supposed to always run in a healthy state. As soon as vibration starts to affect motor run, predictive maintenance needs to be done to recover healthy state.

$V = \pi f D$	$D = \text{Inches pk-to-pk}$ $V = \text{Inches/second}$ $f = \text{Hz (cps) or RPM/60}$ $g = 386.1 \text{ In/sec}^2$
$V = 61.44 \text{ g/f}$	
$g = 0.0511 \text{ fD}$	
$g = 0.0162 \text{ Vf}$	
$D = 0.3183 \text{ V/f}$	
$D = 19.57 \text{ g/f}^2$	

**Fig. 2** Relationships of sinusoidal velocity, acceleration and displacement—Vibration Equations: American Environments Company, Inc.

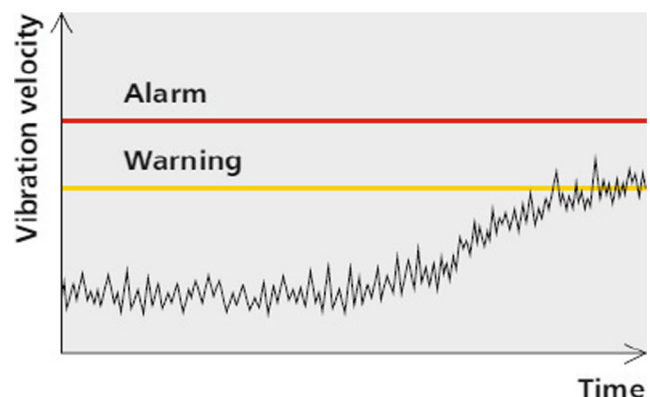

**Fig. 3** Machine vibration trend according to ISO 10816—from process monitoring to vibration analysis—www.ifm.com/gb/octavis

**Table 1** Vibration severity criteria based on ISO 2372

RMS Overall Velocity Level in 1000 Hz Bandwidth		Vibration Severity Criteria			
mm/s	In/s	Class I	Class II	Class III	Class IV
0.28	0.01	Good	Good	Good	Good
0.45	0.02				
0.71	0.03				
1.12	0.04	Satisfactory	Satisfactory	Satisfactory	Satisfactory
1.8	0.07				
2.8	0.11	Unsatisfactory	Unsatisfactory	Satisfactory	Satisfactory
4.5	0.18				
7.1	0.28	Unacceptable	Unacceptable	Unsatisfactory	Unsatisfactory
11.2	0.44				
18	0.71	Unacceptable	Unacceptable	Unacceptable	Unacceptable
28	1.10				
45	1.77				

Case 3, Prevention is always better than cure. When vibration starts to affect the motor, though still in the satisfactory range, it is more likely to be converted into an unacceptable state later on. Case 3 detects velocity in the satisfactory range and sum every hour its value until equal to a velocity in the unsatisfactory and/or unacceptable range. In reality, the actual velocity vibration will not be equal to a value in the unacceptable yet, but this operation is done to prevent any future failure and recover healthy state.

Cases 2 and 3 are considered as warnings. They are not as severe as Case 1 but came back a danger if not attended to as soon as possible.

Using a vibration sensor that will be installed on the conveyor motor, we will collect directly vibration velocity data to the S7-1200 Siemens PLC; vibration sensor being connected as 4–20 mA analogue input.

### 4 Predictive maintenance solution design for conveyor motor using industry 4.0 software approach

#### 4.1 System architecture

The architecture of the overall system displayed on Fig. 25 is done based on the three values I40 concepts emphasize on predictive maintenance as explained in the introduction section of this paper:

- Real-time condition monitoring: The Siemens S7-1200 PLC reads real-time data from the vibration sensor seating on the conveyor motor connected as an analogue input. This data is then processed in the PLC processor with the programmed predictive maintenance rule to generate proper actions. The PLC is also communicating real-time with a SCADA system that displays on its GUI actions to be taken. The predictive maintenance rule is programmed in a flexible way, gathering for easy future changes and editing of the system by technicians and maintenance team without necessarily experts



**Fig. 4** IFM vibration sensors—from process monitoring to vibration analysis—www.ifm.com/gb/octavis

**Fig. 5** Vibration sensor mounted on motor—[https://www.imi-sensors.com/ContentImages/downloads/IMI-App-Motors\\_LowRes.pdf](https://www.imi-sensors.com/ContentImages/downloads/IMI-App-Motors_LowRes.pdf)

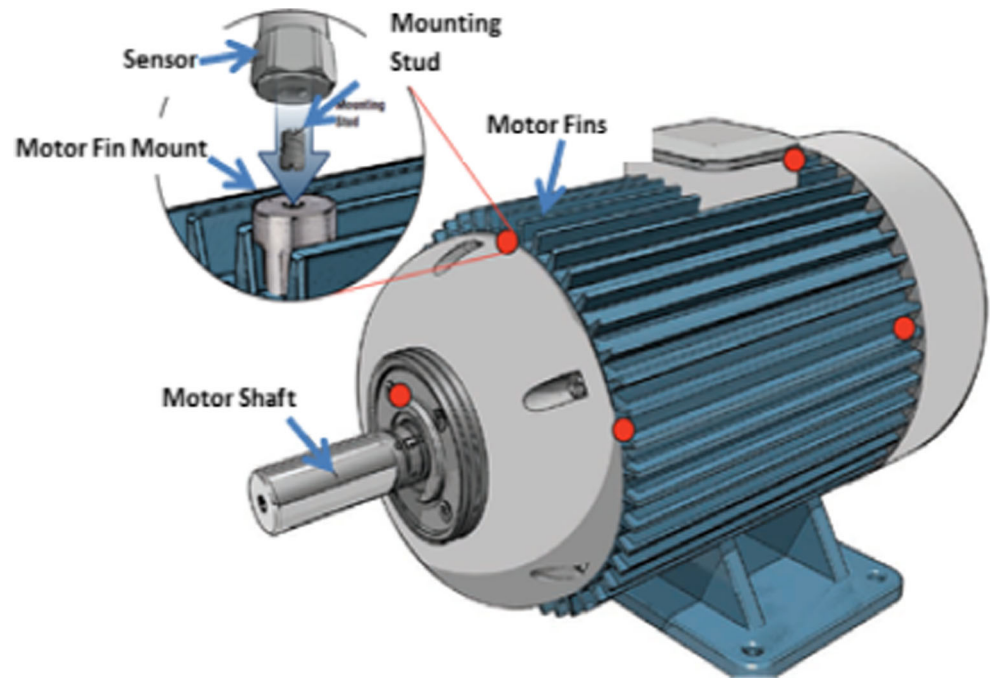

intervention. Figure 26, at the end of the paper, shows the graphical representation of the flexible programming rule.

- Flexible evaluation and analysis options:

When the maintenance team or the technicians are ready to configure a new rule for a specific motor, they only select the right class range of motor size and enter it into the PLC processor via the SCADA interface. The program received the value entered in the buffer, filter the entered data to make sure it falls within the acceptable range of value to enter, match it using a mapping table to the corresponding class of motor size and then apply the rules to the PLC program. With this structure in place, there is no need for an expert to develop again very complicated programs when a new rule needs to be edited or configured.

- Targeted notification of experts:

As soon as a predictive maintenance rule has been generated, the system directly contacts via SMTP email (Fig. 27), the expert in charge of maintaining the motor without waiting for him to rely on the central SCADA information. Traditional standards only used central PLCs and SCADAs to convey any important message: faults, alarms, and statuses to users or operators. In other words, to be aware of system health statuses, one had to be physically in front of the SCADA system or connected to the PLC to monitor important information; this could result in unnecessary delays and late reactions to important system errors. Our paper is solving this issue by transmitting real-time the predictive maintenance schedule once generated to the expert in charge for him to take actions as soon as possible. As

displayed on the overall architecture on Fig. 25, this is done through a python script that will be explained in the next section.

#### 4.2 Predictive maintenance rules: process overview

The process overview of our predictive maintenance rule is divided into three parts corresponding to the three cases of the

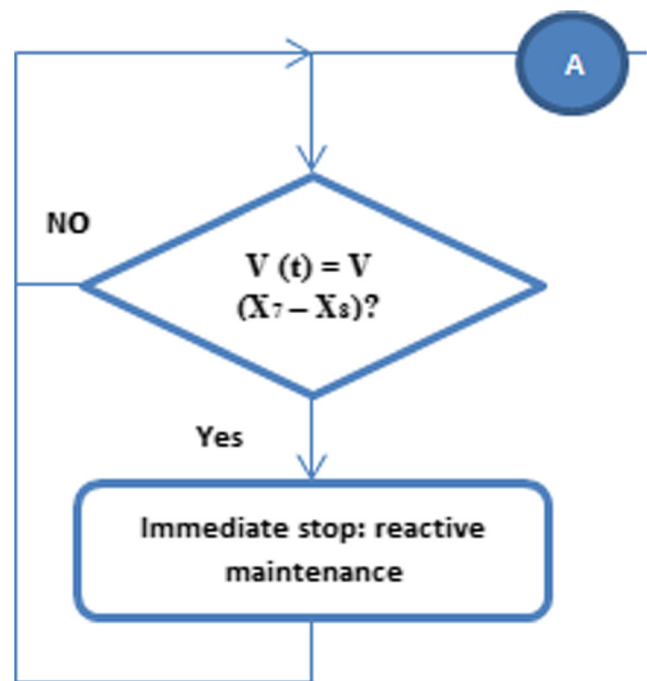

**Fig. 6** Predictive maintenance rule flow chart part 1



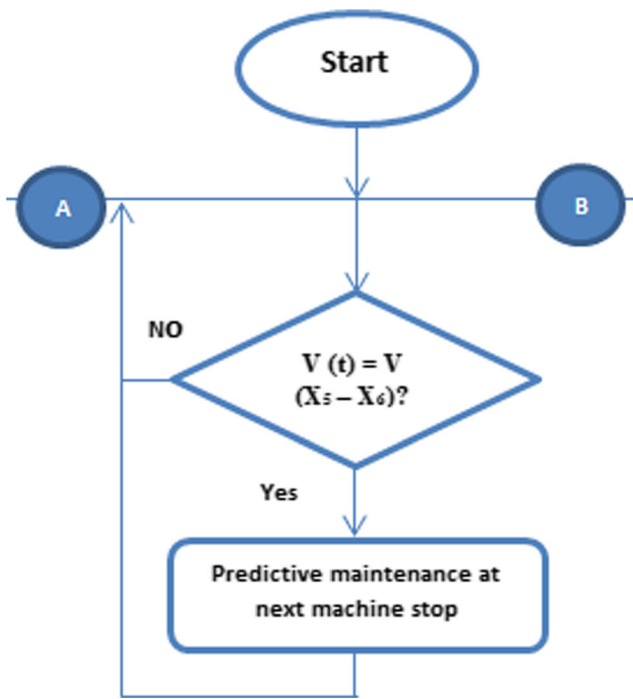

Fig. 7 Predictive maintenance rule flow chart part 2

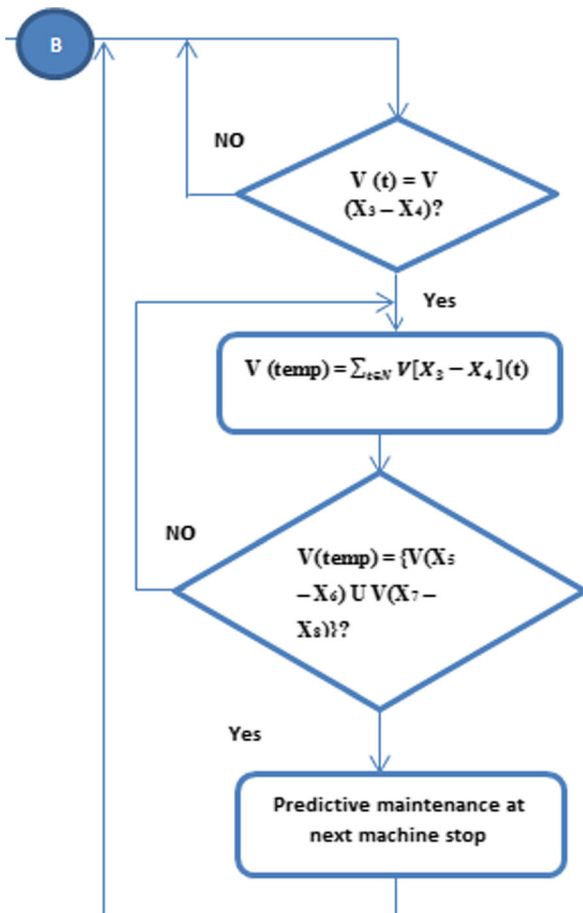

Fig. 8 Predictive maintenance rule flow chart part 3

motor vibration criteria analysis in Section 3. The PLC program will be layout accordingly (Figs. 6, 7, 8):

### 4.3 Predictive maintenance rules programmed in S7-1200 PLC software

As mentioned in Section 3, a vibration sensor is mounted to the motor from which vibration needs to be monitored and the other hand of the sensor is connected to a Siemens S7-1200 PLC which will convert vibration speed to understandable values. In this paper, the vibration sensor is wired as a current (4–20 mA) analogue input to the PLC; and later in the PLC program, reading from the sensor get normalized and scaled (Fig. 9).

Here are the important steps to go through in the PLC in order to read from the vibration sensor:

- Hardware configuration of the PLC to attach the analogue input card (Fig. 28) with the right current settings. Figure 29 at the end of this paper shows the current range configuration on the PLC programming software.

The current rating of the vibration sensor is an important detail to be used in the PLC hardware configuration. This information can be seen on the sensor’s datasheet.

- Conversion of the analogue input through normalization and scaling:

To convert the read analogue input value into understandable vibration speed values, we use two Siemens blocks: NORM\_X and SCALE\_X as displayed on Fig. 30(at the end of this paper). These blocks are used to convert raw analogue inputs from inputs addresses of format IWXXX to logical values.

NORM\_X block converts the Integer value of the analogue input to a real value and feed it into the SCALE\_X block. SCALE\_X converts the real value to a desired range of vibration speed for this application. As per Table 1 , our low limit for the vibration speed in millimeter/second will be 0.28 and higher limit will be 45. Putting these two values as parameter of the SCALE\_X block narrow the range of the output vibration speed that is the actual value we will be constantly monitoring.

- Maintenance rule programmed based on process overview flow charts (Figs. 6, 7, and 8) and vibration severity criteria class I on Table 1 .

Figure 30, displayed at the end of this paper, is a PLC code written to monitor unacceptable vibration speed as per case 1 (Fig. 6).

The first block of Fig. 30 continuously monitors vibration speeds to check if the unacceptable vibration speed range

**Fig. 9** Vibration sensor mounted on motor and connected to PLC—[https://www.imi-sensors.com/ContentImages/downloads/IMI-App-Motors\\_LowRes.pdf](https://www.imi-sensors.com/ContentImages/downloads/IMI-App-Motors_LowRes.pdf)

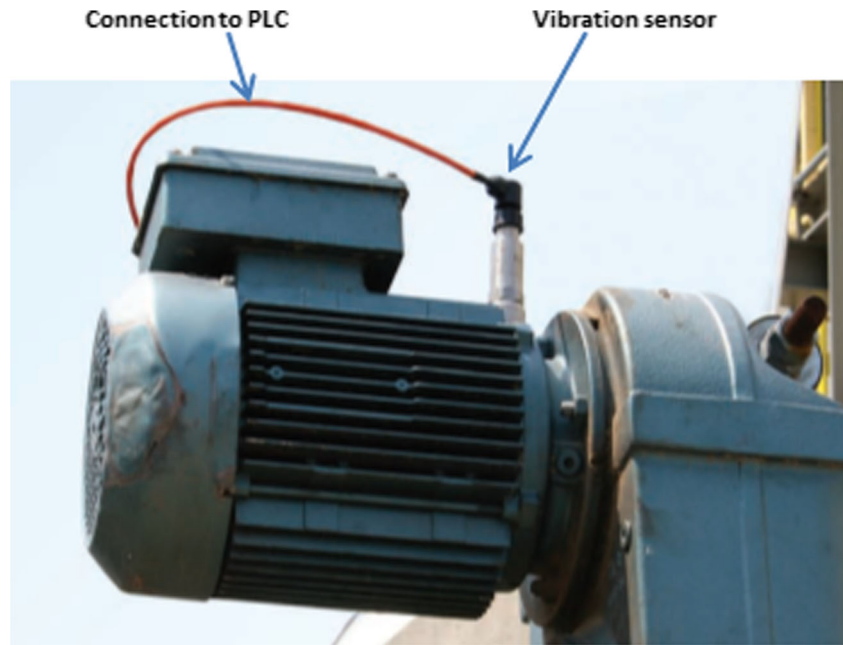

(above 7.1 mm/s in this example) is detected. The second block of the rung in Fig. 30 is the action taken as soon as the unacceptable range of speed is detected. As previously mentioned, this should result in an immediate stop for reactive maintenance and a maintenance expert should be alerted accordingly. The S\_MOVE block writes the string “stop” to a variable that will be recorded in a CSV file and later on read by a python script to send an email notification to the expert. After a delay of 30 s, the variable gets reset to avoid the script sending continuous emails until a new condition will be detected. Figure 31, at the end of this paper, shows how this variable is reset.

The same programming logic will apply for cases 2 and 3 of this study. For the S7-1200 Siemens PLC to write on a CSV file, activate the Web server option on the PLC hardware configuration, and use the data logging create and write from the extended instructions blocks. More information on this procedure is given under S7-1200 PLC data logging on ref. [37].

#### 4.4 Python script configuration for SMTP email transfer to expert

As mentioned in the previous section, the PLC generates a CSV file which contains notifications of predictive maintenance schedule for the conveyor motor. One of our paper’s aims was to move away from a centralized system where any important information is only accessible via the central PLC or SCADA and directly notify maintenance experts in charge real time, anytime, when a schedule is

generated without them having to physical move to the plant. This is achieved by combining a running python script continuously reading the notification in the PLC CSV file and conveying through the internet the corresponding message (email) to the expert. Below is an example of the PLC CSV file format:

The most important parameter in this file is the fourth column (maintenance status). It contains information that the PLC writes based on Fig. 10 logic when a certain condition is met. The python script uses this parameter to trigger the sending of emails.

Here is the skeleton of the python algorithm used to send notifications to experts:

Record	Date	UTC Time	MaintenanceStatus	Count
7	2/09/	0:22:57	start	18
8	2/09/	0:24:14	start	19
9	2/09/	0:25:41	start	20
10	2/09/	0:26:58	start	21
5	2/09/	0:10:03	start	19
6	2/09/	0:20:44	start	17

**Fig. 10** PLC CSV file template

Import all necessities libraries and modules

While (1) // *Continuous script run*

Delay (20 seconds) // *Small processing time to synchronize with PLC*

Open CSV file // *this file has the same name and location as saved on the PLC*

If fourth row = 'stop'

→ Reactive maintenance – Immediate stop

→ Send specific message for reactive maintenance to supervisor // *Email address and settings to be*

*inserted*

Elif (second if) fourth row = 'start'

→ Predictive maintenance – On next machine stop

→ Send specific message for predictive maintenance to supervisor // *Email address and settings to be*

*inserted*

Else: print on compiler “normal operation”

Close CSV file

```
import time
import csv
import smtplib
from email.MIMEMultipart import MIMEMultipart
from email.MIMEText import MIMEText
from email.MIMEBase import MIMEBase
from email import encoders
```

Code 1: import python libraries.

```
while(1):
    time.sleep(20)
    csv_file = open('Test.csv')
    csv_reader = csv.reader(csv_file, delimiter=',')
    next(csv_reader)
```

Code 2: open CSV file.

```
for row in csv_reader:
    if row[3]== "stop":
        print ("Reactive Maintenance - Immediate Stop")
        fromaddr="bottlingplant001@gmail.com"
        toaddr="supervisorbottlingplant001@gmail.com"
        msg=MIMEMultipart()
        msg['From']=fromaddr
        msg['To']=toaddr
        msg['Subject']="Bottling plant 001 - Predictive Maintenance Scheduled"

        body=""Conveyor Motor K1 - Motor Vibration speed > 7.1mm/s!!!
        Please stop operations as soon as possible for reactive maintenance
        of engine!Urgent!!!!"
        msg.attach(MIMEText(body, 'plain'))

        server = smtplib.SMTP('smtp.gmail.com', 587)
        server.starttls()
        server.login(fromaddr,SENDING_EMAIL_PASSWORD)
        text=msg.as_string()
        server.sendmail(fromaddr,toaddr,text)
        print "done!"
        server.quit()
```

Code 3: send email to maintenance expert.

#### 4.5 Decentralized cloud-based dashboard monitoring tool

Another advantage of Industry 4.0 used in this paper is the creation of a decentralized monitoring dashboard system. The PLC constantly monitoring motor vibration speed from the vibration sensor saves it in a CSV file as described by [37].

The saved CSV file is loaded in a local MySQL database through an application programming interface (API) (programming scripts); the MySQL database is then loaded via another API and through the Internet to a cloud-based reporting called ClicData. In the reporting tool, the desired graphical dashboard is designed and linked to the MySQL database for automatic update based on vibration speed changes. The reporting tool also generates a protected internet link that supervisors can use on their desktops, laptops, tablets, or smart phones with Internet access to monitor the dashboard. Figure 11 is a very good representation of all components involved for the creation of a decentralized cloud-based monitoring tool.

The dashboard is accessible through an internet browser link:

<https://theraintel.clicdata.com/v/YgPGRCamDfIO>

#### 4.6 Experimental results and analysis

Three main platforms are used for the analysis and results of the predictive maintenance strategy:

- The first platform is WinCC SCADA GUI software that instantaneously displays on a human machine interface (HMI), within the plant, a notification of predictive and reactive maintenance. The SCADA communicates with the PLC (via Ethernet protocol) from which it reads motor vibration speed states as programmed based on cases 1–3 of the previous section and alerts operators accordingly.

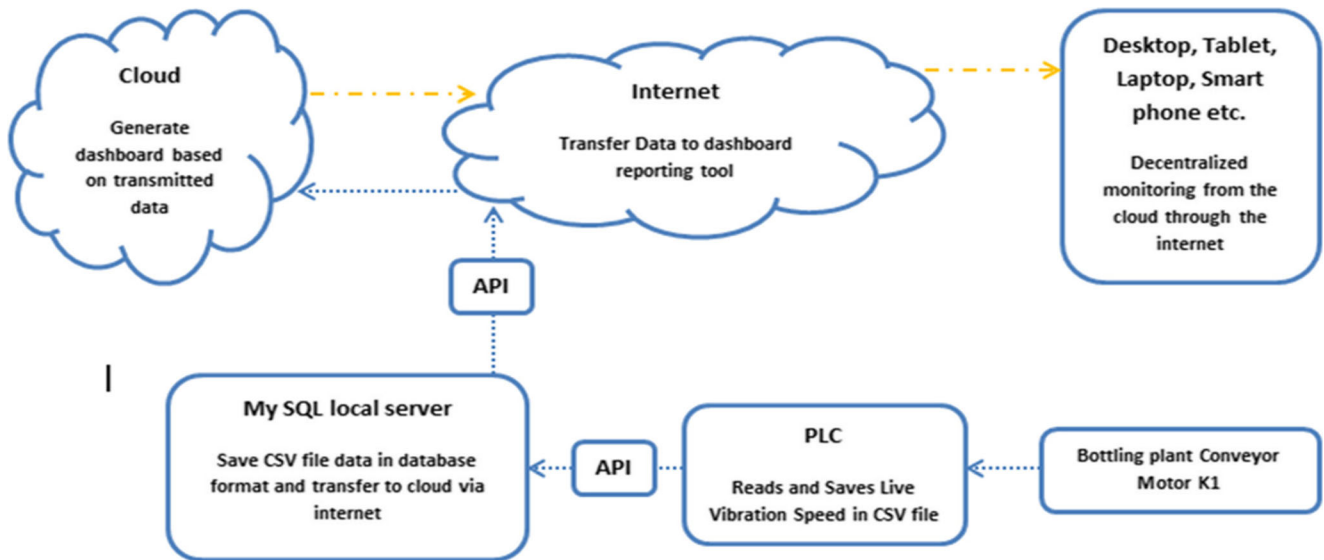

Fig. 11 Decentralized vibration speed monitoring through cloud-based reporting tool

The SCADA system is also programmed as a flexible configuration interface for new predictive maintenance rules.

- The second platform used in the analysis is the email notification system from the bottling plant to the supervisor in charge of motor’s maintenance. Two main emails are used: the sender that is the bottling plant email address and the recipient and the maintenance supervisor’s email address. These notifications are initiated real time by a close communication between PLC and an email scripting system (codes 1–3).
- The last platform used is a decentralized monitoring dashboard of the motor vibration severity criteria as described

on Table 1. The monitoring dashboard is developed on a cloud-based reporting tool called ClicData and accessible via Internet. The reporting tool communicates with a local MySQL database through an API from which it receives continuous updates of the actual vibration speed as read by the PLC (Fig. 11).

The SCADA GUI which is both an external representation of PLC’s operation and an interface between the operators and the overall system has two main important screens:

- The parameters setting screen: where the maintenance technicians edit or configure new predictive maintenance rules for different motors’ size, different vibration criteria. For this paper, the vibration criteria on Table 1 was used.

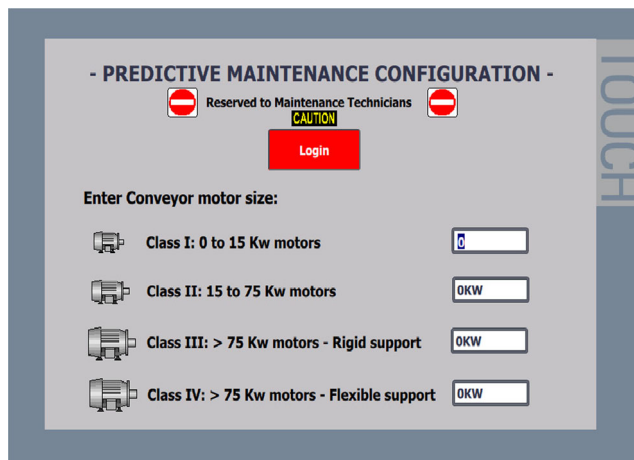

Fig. 12 Predictive maintenance settings for motors

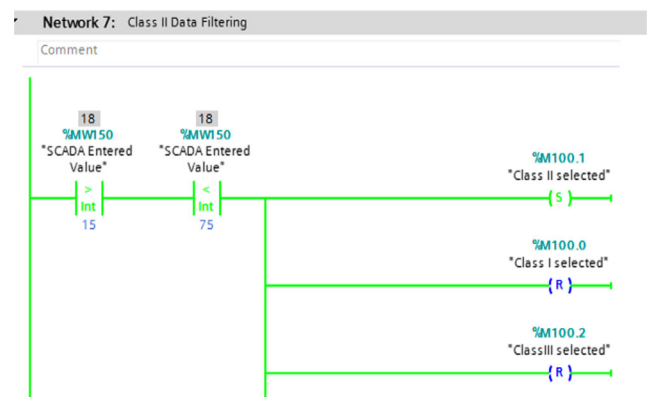

Fig. 13 Class II data filtering in PLC software

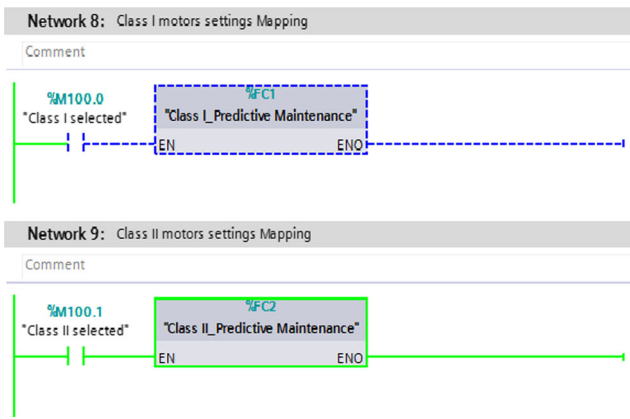

Fig. 14 Class II motors data mapping

Only maintenance technicians are entitled to do configurations, therefore user identification is required to keep track of changes performed in the system.

For more flexibility when editing or configuring predictive maintenance rules for the system, PLC and SCADA are working together based on the programming structure in Fig. 26 in which the entered data on the above Fig. 12 are first received by the SCADA in a buffer, filtered, mapped to the corresponding class of motors predefined in the PLC software and then applied to the operations:

Figure 13 above is an example of data filtering in PLC language for class II as per Table 1. The entered data in the SCADA is equal to 18 kW, which matches the second motor’s class (motors sizes between 15 and 75 kW). After filtering of data, there is data mapping which is the selection of the corresponding class II function to be applied for PLC operations. Figure 14 shows how the data mapping is done in the PLC code.

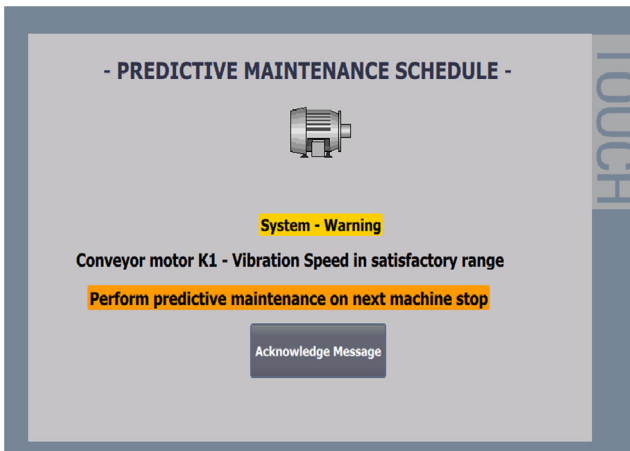

Fig. 15. Predictive maintenance schedule message screen

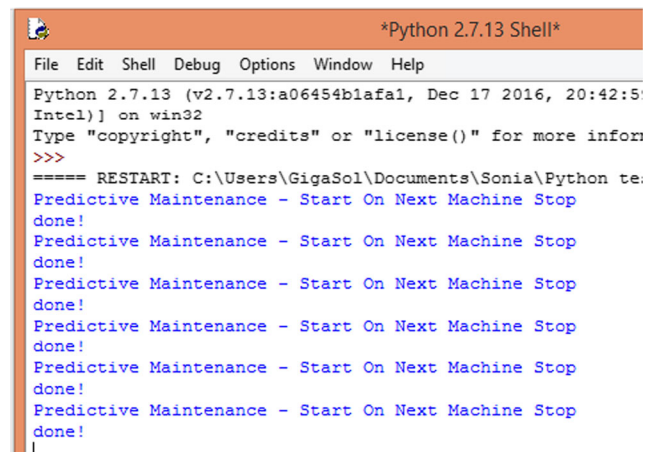

Fig. 16 Python script running on compiler—predictive maintenance detected

- The message schedule screen: where notification of reactive or predictive maintenance are displayed for actions to be taken. Figure 15 shows one of the SCADA message screens for predictive maintenance.

As soon as predictive maintenance is scheduled and displayed on the SCADA’s screen, the running python script reads a value change in the CSV file written by the PLC and automatically sends an email to the supervisor in change of maintenance for the bottling plant. In our platform, the email is sent more than once (six times) corresponding to the number of lines in the CSV file to make sure that the supervisor gets properly notified (Figs. 16 and 17).

As previously mentioned, a decentralized monitoring dashboard of the motor vibration evolution is available in

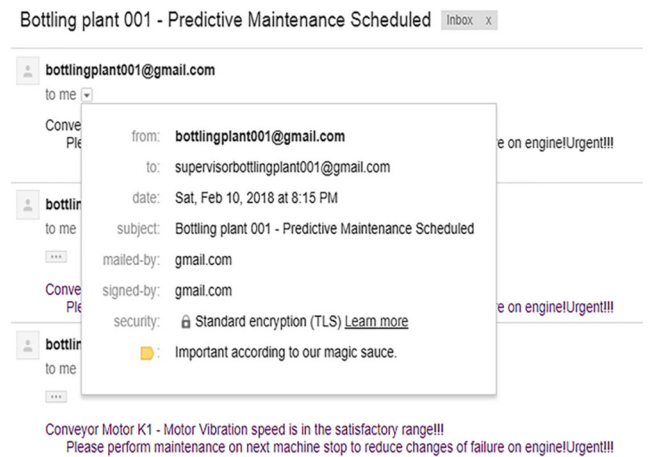
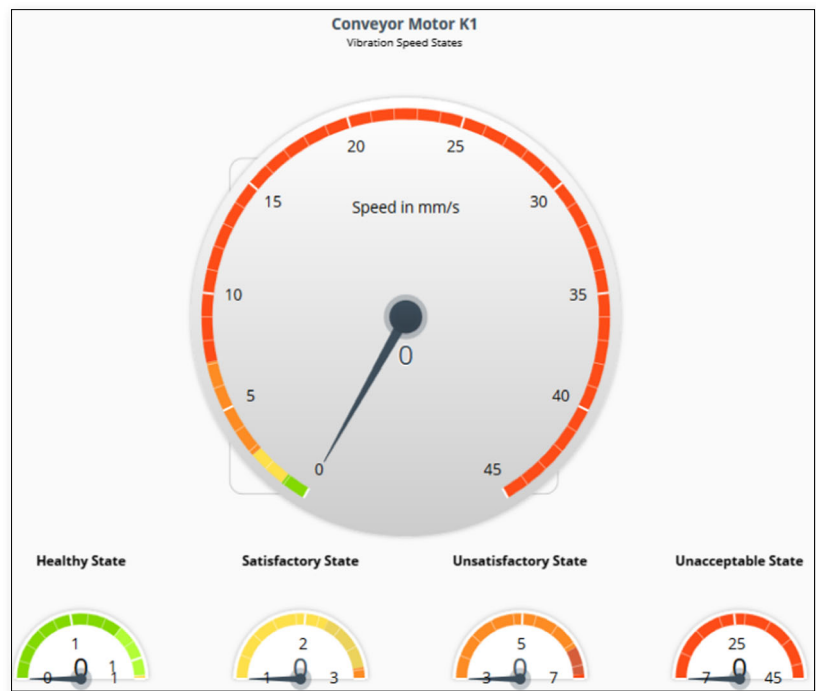

Fig. 17 Predictive maintenance email received by supervisor from bottling plant

**Fig. 18** Conveyor motor vibration in healthy state



a cloud-based reporting tool (ClicData). Wherever they are, when connected to the Internet, supervisors can monitor the evolution of different motor vibration speed states and anticipate preparation of a maintenance schedule. The online dashboard represents some self-explanatory

graphical gauges of the motor vibration severity criteria in Table 1. Data on the dashboard is updated real-time from a local MySQL server which receives real-time vibration speed from the PLC CSV file database. The PLC itself reads vibration speed from the vibration sensor mounted

**Fig. 19** Conveyor motor in satisfactory state

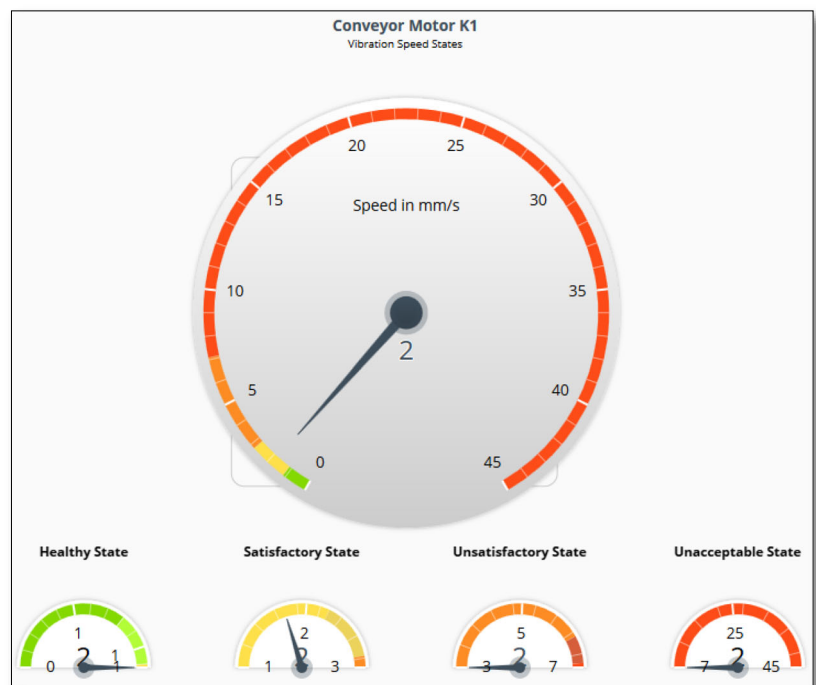

**Fig. 20** Conveyor motor in unsatisfactory state



on the conveyor motor (Fig. 9). Below are the gauges states available on the online monitoring tool (Figs. 18, 19, 20, 21):

Figures 22, 23, and 24 below are two graphs displaying the impact of our predictive maintenance strategy over systems using normal periodic and reactive maintenance:

**Fig. 21** Conveyor motor in unacceptable state

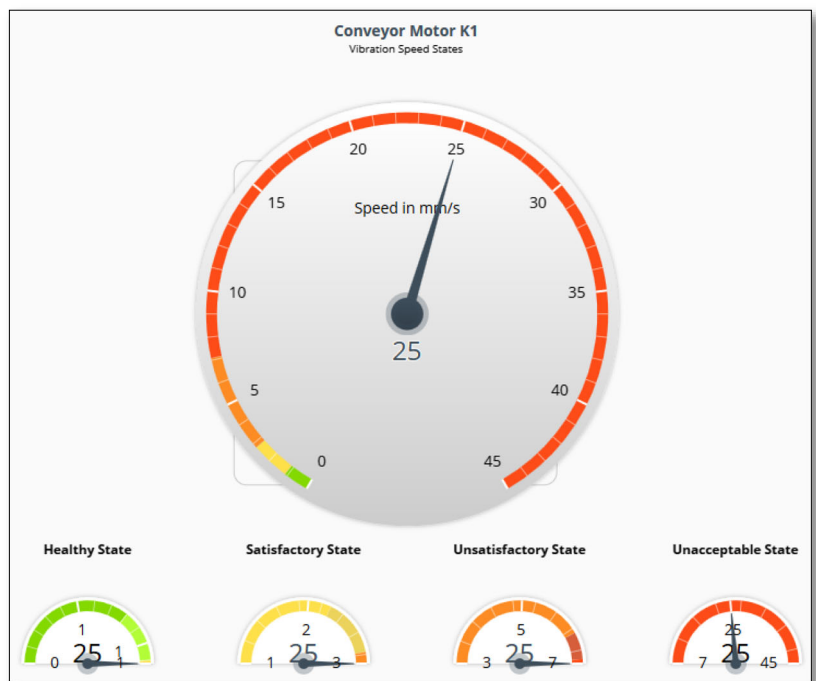

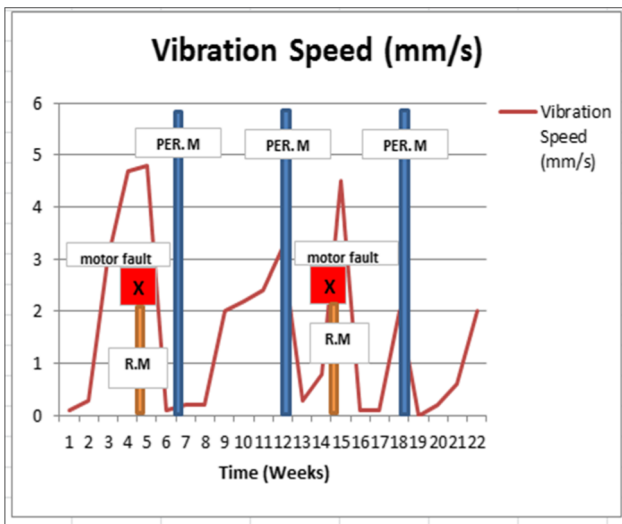

Fig. 22 Motor vibration speed in a system without predictive maintenance

Most of the time, failures on a motor do not happen instantaneously; it is a progressive state that deteriorates with time motor’s health. In this approach, an increase of vibration speed is the main reason of faults. Figure 22 displays the motor vibration speed stages without using predictive maintenance strategy. The system waits for a predefined time before maintaining the motor (periodic maintenance) or for a fault to occur in the system (reactive maintenance). Unplanned outages, represented by vibration speed increase on both graphs, always exist in real plants. Vibration speeds of a motor will increase until they reach an unacceptable state resulting in motor failure. Waiting for a specific time to perform maintenance of the motor is therefore a risk to spend more resources on reactive maintenance.

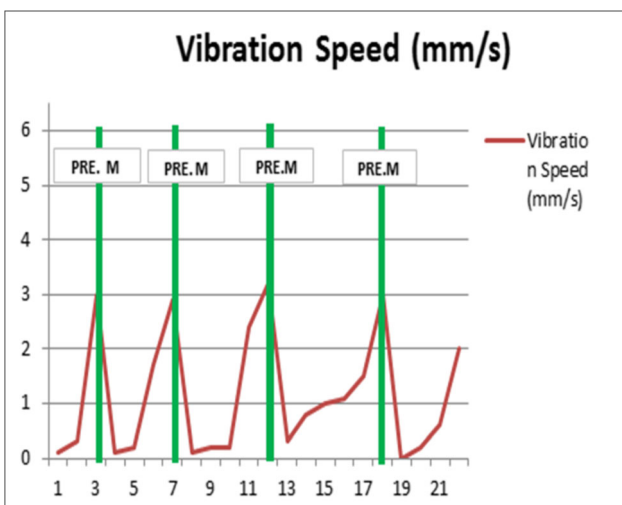

Fig. 23 Motor vibration speed in a system with our predictive maintenance schedule

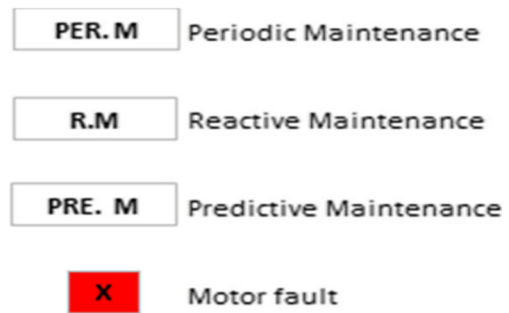

Fig. 24 Legends of Figs. 22 and 23

On the other hand, Fig. 23 shows a system in which our predictive maintenance schedule, as developed in cases 1–3, is implemented. It is very unlikely for this system to experience motor unplanned failure because it continuously monitors the speed states. As per our strategy, the only safe state for motor operation is the healthy state defined in Table 1 vibration severity criteria: between 0.28 and 1.12 mm/s. Any increase of speed falling in the satisfactory range will generate after the configured time (case 2) a predictive maintenance schedule and reduce risks to reach to unsatisfactory speed range.

### 5 Conclusion

In this paper, an effective predictive maintenance strategy for a conveyor motor based on Industry 4.0 concepts was proposed. In the proposed strategy, we have rigorously analyzed real-time vibration speed data collected from a vibration sensor mounted on the conveyor motor and connected to a Siemens S7-1200 PLC. From the analyzed data saved in the PLC, early motors threats were automatically detected based on ISO 2372 vibration severity criteria and predictive maintenance schedule was generated accordingly. Furthermore, the strategy proposed a decentralized monitoring system for the conveyor motor; it included a cloud-based dashboard report displaying real-time vibration speed states; and an instant email notification system from the bottling plant to the intended supervisor for every maintenance schedule generated.

**Acknowledgments** This research is supported partially by South African National Research Foundation Grants (Nos. 112108 and 112142), South African National Research Foundation Incentive Grant (No. 114911), and Tertiary Education Support Programme (TESP) of South African ESKOM.

**Publisher’s Note** Springer Nature remains neutral with regard to jurisdictional claims in published maps and institutional affiliations.



### Appendix—Some Figures

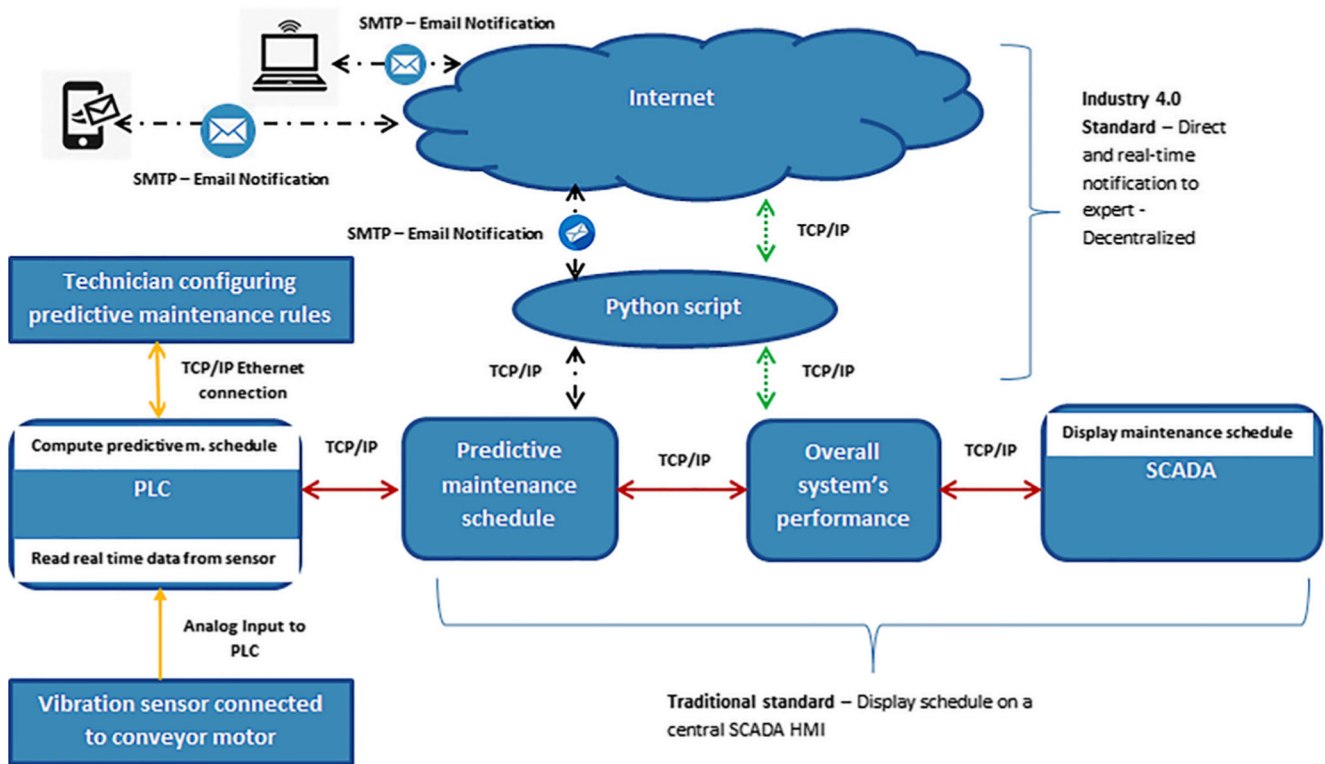

Fig. 25 Overall system's architecture

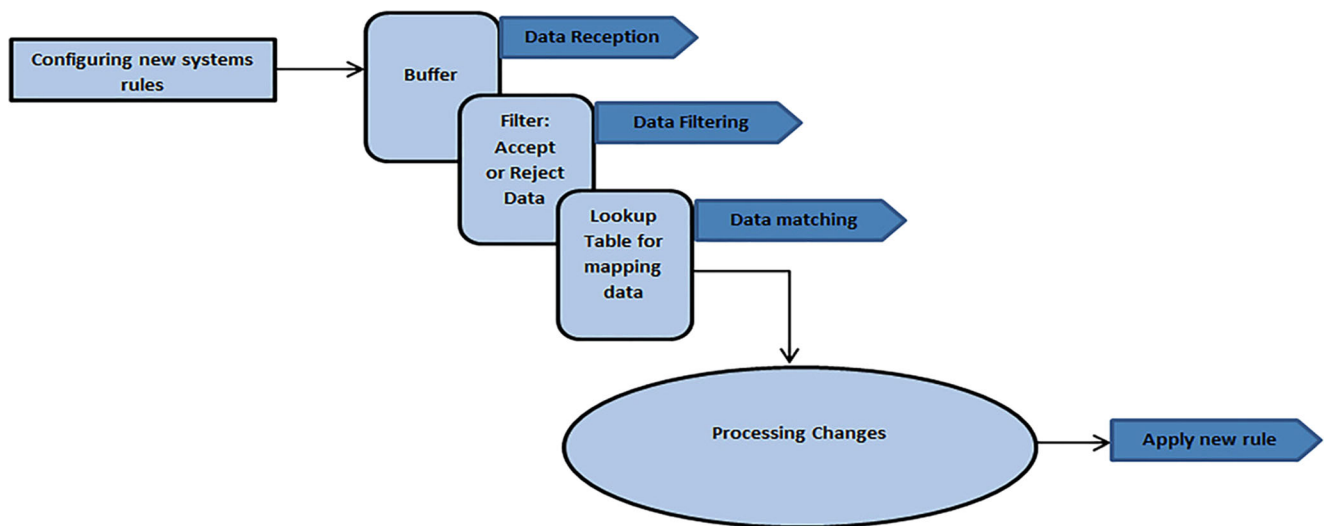

Fig. 26 Flexible predictive maintenance rule programming structure

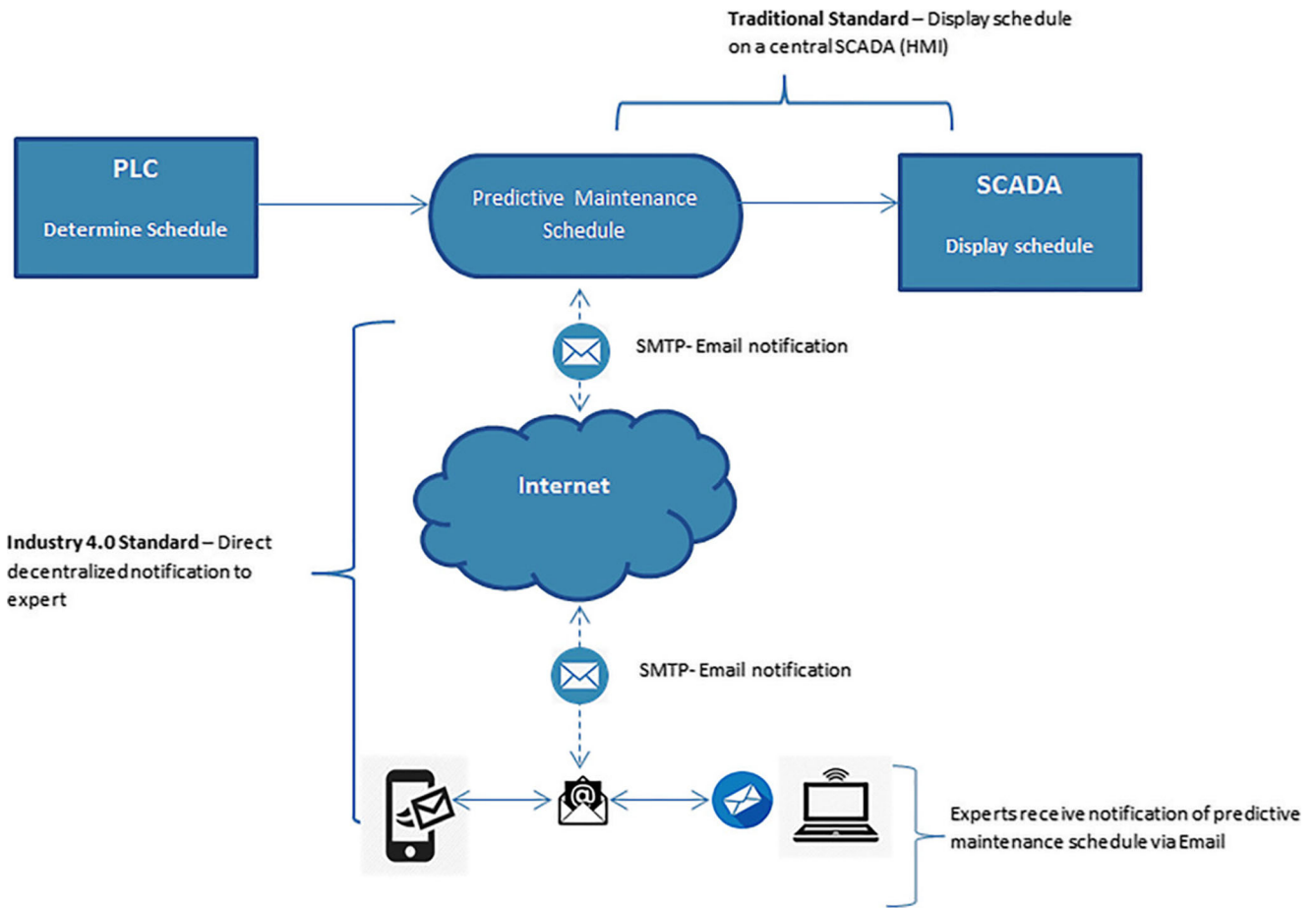

Fig. 27 SMTP Email targeted notification to expert layout

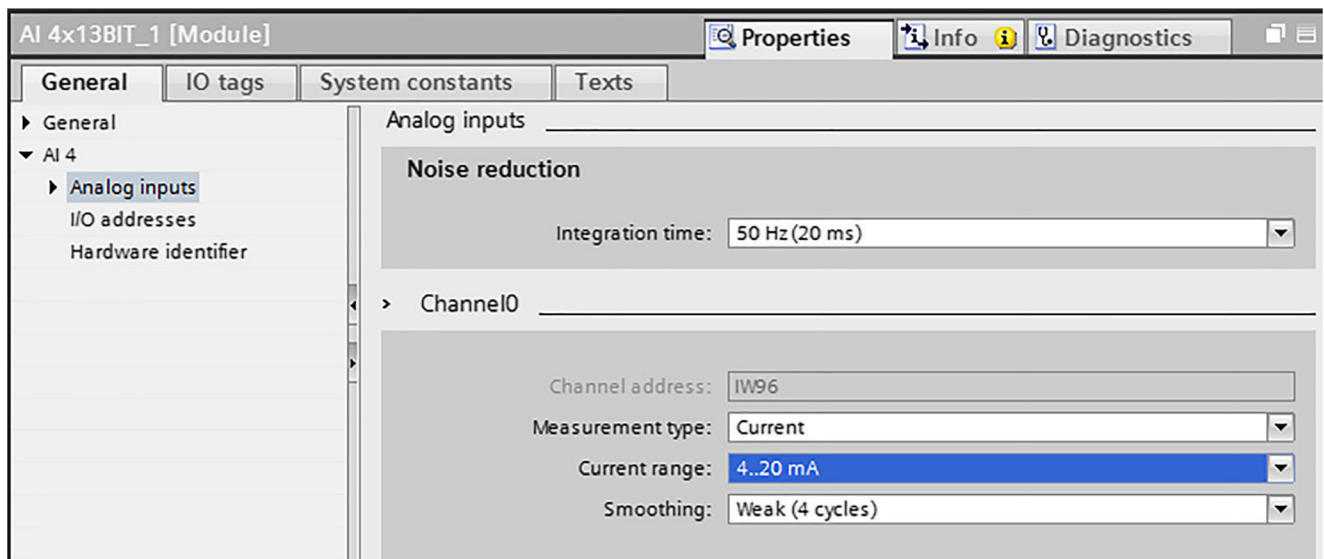

Fig. 28 Analogue input configuration in PLC hardware configuration

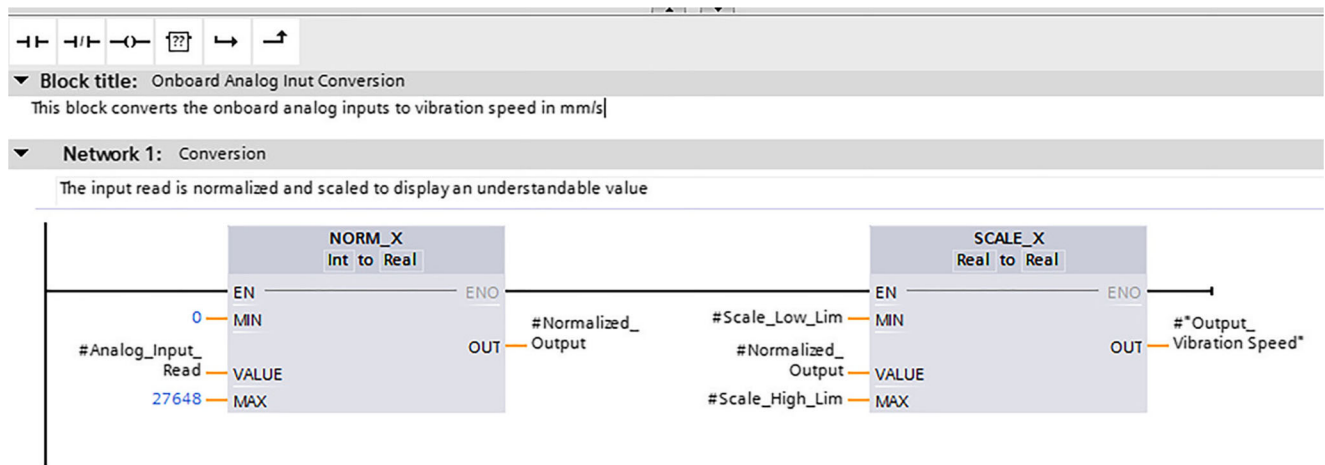

Fig. 29 Analogue input conversion to a real value

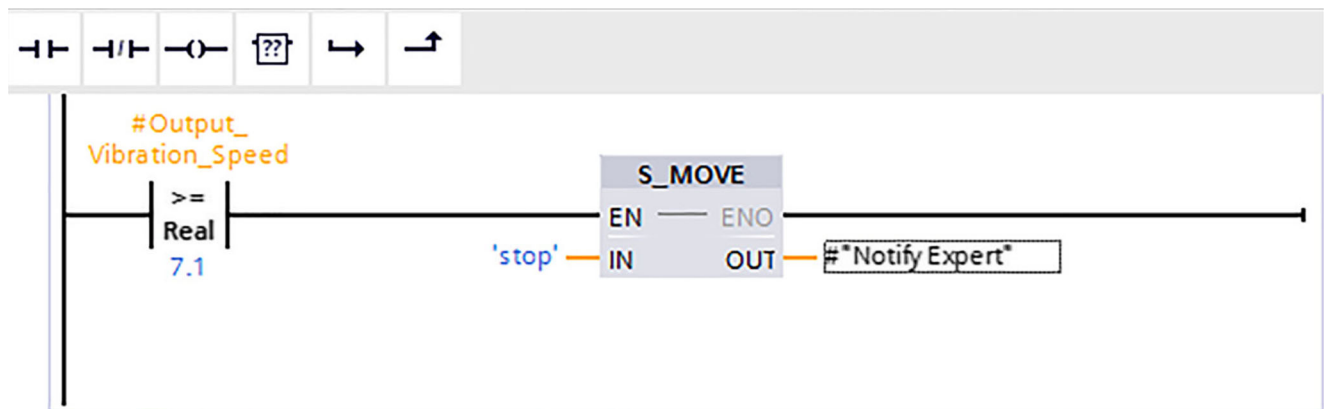

Fig. 30 Vibration speed unacceptable range detection

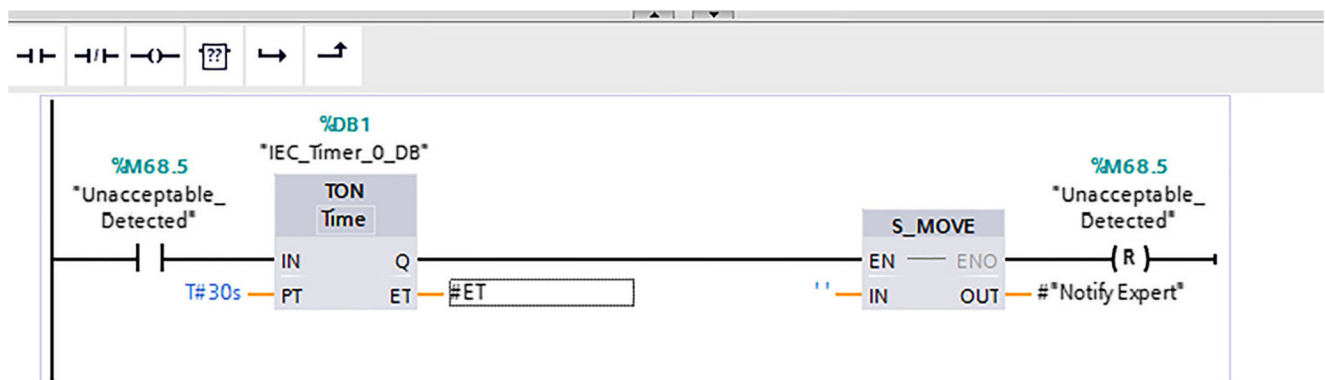

Fig. 31 Reset expert notification variable

## References

- Colin Sanders (2011) A guide to vibration analysis and associated techniques in condition monitoring. DAK Consulting - Chiltern House [http://www.dakacademy.com/newsite/index.php?option=com\\_k2&Itemid=500&id=94\\_007cd4b8b347-e375bc10dbe5efbcc28&lang=en&task=download&view=item:3-8](http://www.dakacademy.com/newsite/index.php?option=com_k2&Itemid=500&id=94_007cd4b8b347-e375bc10dbe5efbcc28&lang=en&task=download&view=item:3-8)
- K. Wang, Y. Wang, J.O. Strandhagen, T Yu (2016) Advanced manufacturing and automation V. WIT transactions on engineering sciences, Vol 113 Press WIT: 263–264
- Marcel Kohler (2016) Industry 4.0 provides new possibilities for predictive maintenance. <https://blog.bosch-si.com/industry40/industry-4-0-provides-new-possibilities-for-preventive-maintenance/>
- Vanraj, D. Goyal, A. Saini, S. S. Dhami, B. S. Pabla (2016) Intelligent predictive maintenance of dynamic systems using condition monitoring and signal processing techniques—a review. International conference on Advances in Computing, Communication and Automation (ICACCA): 1–6
- IFM Electronics (2013) From process monitoring to vibration analysis, condition monitoring systems [http://www.ifm.com/download/files/ifm-efector-octavis-brochure-GB-2013/\\$file/ifm-efector-octavis-brochure-GB-2013.pdf](http://www.ifm.com/download/files/ifm-efector-octavis-brochure-GB-2013/$file/ifm-efector-octavis-brochure-GB-2013.pdf): 5–12
- R. Petrasch, R. Hentschke (2016) Process modelling for Industry 4.0 applications: towards an Industry 4.0 process modelling language and method. 13th International Joint Conference on Computer Science and Software Engineering (JCSSE): 1–5
- T. Niesen, C. Houy, P. Fettke, P. Loos (2016) Towards an integrative big data analysis framework for data-driven risk management in Industry 4.0. 49th Hawaii international conference on system Sciences: 5056–5074
- C.Y. Park, K.B. Laskey, S. Salim, J.Y. Lee (2017) Predictive situation awareness model for smart manufacturing. 20th international conference on information fusion: 1–8
- Atzori, L., Lera A., Morabito G. (2010) The internet of things: a survey In: *Comput Netw* Vol 54: 2787–2805
- Lee J, Bagheri B, Jin C (2016) Introduction to cyber manufacturing. *Manuf Lett* 8:11–15
- Mi, M., Zolotov, I., (2016) Comparison between multiclass classifiers and deep learning with focus on industry 4.0. In 2016 Cybernetics & Informatics (K&I): 1–5
- Monostori L (2014) Cyber-physical production systems: roots, expectations and R&D challenges. *Procedia CIRP* 17:9–13
- Ollif H, Liu Y (2017) Towards Industry 4.0 utilizing data-mining techniques: a case study on quality improvement. *Procedia CIRP* 63:167–172
- Lu, Y., Morris, K. C., & Frechette, S. (2016) Current standards landscape for smart manufacturing systems. National Institute of Standards and Technology, NISTIR: 8107
- Harpreet S.D (2017) ERP Implementation: Top five challenges for SMEs [online] <https://economictimes.indiatimes.com/small-biz/sme-sector/erp-implementation-top-five-challenges-for-smes/articleshow/57034195.cms>
- Upkar S.A., (2014) Should SMEs automate? <http://autocomponentsindia.com/should-smes-automate/>
- Adolph S., Tisch M., Metternich J., (2014) Challenges and approaches to competency development for future production. *Journal of International Scientific Publications—Educational Alternatives*: 1001–1010
- Upkar S.A., Kumar C.S, Gopal K.P, Parthasathy, Rathee R.S. (2014) Should SMEs automate? <http://autocomponentsindia.com/should-smes-automate/>
- Hashemian HM (2011) State-of-the-art predictive maintenance techniques. *IEEE Trans Instrum Meas* 60(1):226–236
- G. Hale (2007) Intech survey: predictive maintenance top technology challenge. ISA: International Society of Automation, 54: 20
- H. M. Hashemian (1998), U.S. Nuclear Regulatory Commission, Office of Nuclear Regulatory Research, division of systems technology, and analysis and measurement services corporation, advanced instrumentation and maintenance technologies for nuclear power plants. Washington, DC: division of systems technology, Office of Nuclear Regulatory Research, U.S. Nuclear Regulatory Commission: U.S. G.P.O: distributor o CLC: 42358049
- Lee J, Wu F, Zhao W, Ghaffari M, Liao L, Siegel D (2014) Prognostics and health management design for rotary machinery systems reviews, methodology and applications. *Mech Syst Signal Process* 42:314–334
- Fu C, Ye L, Liu Y, Yu R, Iung B, Cheng Y, Zeng Y (2004) Predictive maintenance in intelligent-control-maintenance-management system for hydroelectric generating unit. *IEEE Trans Energy Conversion* 19:179–186
- R. K. Mobley (2011) *Maintenance fundamentals*. 2nd ed. Butterworth-Heinemann ISBN 9780080478982
- Carnero MC (2006) An evaluation system of the setting up of predictive maintenance programmes. *Reliab Eng Syst Saf* 91(8, ISSN 0951-8320):945–963
- I. Mustakerov, D. Borissova (2013) An intelligent approach to optimal predictive maintenance strategy defining. *IEEE INISTA*: 1–5
- Borissova D, Mustakerov I, Grigorova V (2011) Engineering systems maintenance by optimal decision making strategies under uncertainty conditions. *Problems Eng Cybern Robot* 63:14–21
- Ch. C. Aggarwal (2013), *Managing and Mining Sensor Data*, Springer, ISBN 978-1-48999-238-3: 534
- L. Spendla, M. Kebisek, P. Tanuska, L. Hrcka (2017) Concept of predictive maintenance of production systems in accordance with industry 4.0. *IEEE 15<sup>th</sup> International Symposium on Applied Machine Intelligence and Informatics (SAMII)*: 000405 – 000410
- T. Borgi, A. Hidriy, B. Neefz, M.S. Naceur (2017) Data analytics for predictive maintenance of industrial robots. *International Conference on Advanced Systems and Electric Technologies (ICASET)*: 412–417
- J. Zhou, X. Li, A.J.R. Andernroomer, H. Zeng, K.M. Goh, Y.S. Wong, G.S. Hong (2005) Intelligent prediction monitoring system for predictive maintenance in manufacturing. 31<sup>st</sup> annual conference of IEEE industrial electronics society IECON: 2314–2319
- Jemielniak K (1999) Commercial tool condition monitoring systems. *Int J Adv Manuf Technol* 15(10):711–721
- W. Yang, P.J. Tavner, C.J. Crabtree1, Michael Wilkinson (2008) Research on a simple, cheap but globally effective condition monitoring technique for wind turbines. *Proceedings of the International Conference on Electrical Machines*: 1–5
- C. Gu, Y. He, X. Han, Z. Chen (2017): Product quality oriented predictive maintenance strategy for manufacturing systems. *Prognostics and System Health Management Conference (PHM-Harbin)*: 1–7
- Keefer (2008) *Principles and practices of vibrational analysis*. GEA FES systems Inc., Vibration Analysis Services, Basics of vibrations: 8–15
- R.R Pereira, V.A.D. da Silva, J.N. Brito, J. D. Nolasco (2016) Online monitoring induction motors by fuzzy logic—a study for predictive maintenance operators. 12th international conference on

- natural computation, Fuzzy Systems and Knowledge Discovery (ICNC-FSKD): 1341 – 1346
37. Otto Gottlieb (2015) Data logging with Siemens S7-1200 PLC. <https://www.dmcinfo.com/latest-thinking/blog/id/9108/data-logging-with-siemens-s7-1200-plcs>
  38. Peng Y, Dong M, Zuo MJ (2010) Current status of machine prognostics in condition-based maintenance: a review. *Int J Adv Manuf Technol* 50(1):297–313