

Feature shape complexity: a new criterion for the simplification of feature-based 3D CAD models

Soonjo Kwon¹ · Duhwan Mun² · Byung Chul Kim³ · Soonhung Han¹

Received: 18 January 2016 / Accepted: 16 May 2016 / Published online: 24 May 2016
© Springer-Verlag London 2016

Abstract Three-dimensional computer-aided design (3D CAD) models with different levels of detail (LOD) are used in various industries for numerous purposes. Therefore, it is necessary to develop techniques to simplify 3D CAD models in order to adjust the LOD of the model according to its purpose. The main purpose of simplification is to minimize the change in the outer shape of the models and to reduce the data size of the models. The key technologies to achieve these purposes are evaluation metrics and simplification operation. Evaluation metrics are employed to select elements to be preserved or removed by calculating the importance of the geometric elements comprising a 3D CAD model. The simplification operation removes the selected elements and fills up the void in the model caused by the removal. Feature volume and type have been the most popular criteria used in evaluation metrics for the simplification of feature-based 3D CAD models. In this study, the concept of feature shape complexity (FSC) is introduced, and a method of adopting FSC as a criterion of evaluation metrics is presented. A prototype system for the simplification of 3D CAD models is then implemented. Finally, the effectiveness of the proposed method is verified

by conducting simplification experiments with a complex 3D CAD assembly model.

Keywords Evaluation metrics · Level of detail · Feature shape complexity · Feature-based 3D CAD model · Simplification operation

1 Introduction

Three-dimensional computer-aided design (3D CAD) models with different levels of detail (LOD) are widely used for numerous purposes in various industries. These models will be more reliable if users can flexibly control their LODs. However, users have to create models with different LODs manually, and this is a time-consuming and expensive process [1]. Therefore, it is necessary to develop techniques to simplify 3D CAD models in order to adjust the LOD of the model according to its purpose.

The most typical example of simplification techniques is removing the detailed shapes of 3D CAD models to shorten the time required for finite element analysis in product design [2]. In the field of virtual reality, mesh models are generally used, and simplification techniques are necessary to reduce the number of meshes and preserve the outer shape of the model at the same time because of the limitations of graphic devices and computing power [3]. In the plant industry, the equipment supplier creates high-complexity 3D CAD models to manufacture equipment and provides these models to an engineering, procurement, and construction (EPC) company. Here, the EPC company, which focuses mainly on installing the equipment, needs to simplify the models while preserving vital information such as ports and outer boundaries in order to use them in the detailed design [4].

✉ Soonhung Han
shhan@kaist.ac.kr

¹ Department of Mechanical Engineering, Graduate School of Ocean Systems Engineering, Korea Advanced Institute of Science and Technology, 291 Daehak-ro, Yuseong-gu, Daejeon 305-701, South Korea

² Department of Precision Mechanical Engineering, Kyungpook National University, 2559, Gyeongsang-daero, Sangju, Gyeongsangbuk-do 742-711, South Korea

³ Department of Mechanical Engineering, Dong-A University, 37, Nakdong-daero 550beon-gil, Saha-gu, Busan 604-714, South Korea

The key technologies for simplifying 3D CAD models are evaluation metrics and simplification operations. Using evaluation metrics, the importance of each element comprising 3D CAD models can be calculated; hence, these metrics are essential for selecting the elements that need to be preserved or removed. The evaluation metrics select the vertices or edges to be removed in polygonal models and select the removable feature in feature-based models. The simplification operation removes the selected element and fills up the void caused by the removal. Simplification operations such as edge collapse, wrap-around operation, Boolean operation, and feature rearrangement are applied depending on the model types [5–7]. Previous researchers have aimed mainly at minimizing the change in the outer shape of the original model while reducing the data size.

Previous studies on the simplification of 3D CAD models can be categorized into the following three approaches: polygon-based [8–10], boundary representation (b-rep)-based [11, 12], and feature-based [1, 4, 6, 7, 13, 14]. The polygon-based approach is mainly adopted for computer graphics, and models with regular and dense meshes tend to yield good simplification results. However, the main features of the original model are prone to be distorted at low LODs in this approach. In the b-rep-based approach, certain types of local features such as fillets, chamfers, and holes are detected by pattern matching of topological information, and then the detected features are removed [11]. The feature-based approach simplifies a model by rearranging features in the order of importance and removing less important features until the desired LOD value is achieved. Feature volume and type are common criteria used in the evaluation metrics that can calculate the importance of features.

Complexity is generally used to characterize something with many parts where these parts interact with each other in multiple ways [15]. Complexity is a representative measure used for decision making in many engineering applications. For instance, Rodriguez-Toro et al. [16] proposed a way to use several factors such as the number of components, manufacturing complexity, process complexity, structural complexity, and sequence complexity in order to evaluate the overall complexity of manufacturing processes so that the overall complexity is utilized in assembly planning.

The complexity of a 3D shape is a metric that quantitatively calculates the shape complexity of the 3D CAD model by using the number of elements, type of elements, and relationship among elements. Pellerin et al. [17] suggested a method to analyze terrains by making use of the structural complexity of mesh models for terrains. Valentan et al. [18] introduced a part complexity based on the surface area, volume, and the number of triangles of a mesh model in order to determine the orders of turning and milling operations in additive fabrication.

This study applies the concept of complexity to the simplification of a feature-based 3D CAD model and proposes feature shape complexity (FSC) as a new simplification criterion. The proposed FSC comprises volume complexity and element complexity, and its numeric value can be calculated. The evaluation metrics for simplification are also defined considering FSC. These metrics reflect not only FSC but also exclusive priorities such as ports, outer boundaries, and internal features. Simplifying a feature-based 3D CAD model based on the proposed evaluation metrics has the advantages of maintaining the outer shape of the model while reducing the data size of the model.

In this paper, a method to simplify a feature-based 3D CAD model is introduced in Section 2. In Section 3, the concept, composition, and significance of FSC are explained. In Section 4, the implementation of a prototype system to verify the proposed method and the results of simplification experiments for test cases are described. Finally, our closing remarks and a summary are given in Section 5.

2 Simplification of feature-based 3D CAD models

2.1 Overall procedure

Figure 1 shows the overall procedure of the proposed approach for simplifying feature-based 3D CAD models. Users first import a feature-based 3D CAD assembly model. Nongeometric information such as ports and specification can also be imported, if necessary. Users then select the component (subassembly) to be simplified. After selecting the component, FSC is calculated to determine the importance of the features comprising the component (subassembly). Then, the features representing ports, outer boundaries, and internal features are detected to assign exclusive priorities.

First, the importance of features is determined by using the evaluation metrics based on exclusive priorities and by using FSC; the features are then rearranged according to their importance. Users determine the optimal LOD for each component, and the simplification system progressively removes features with lower importance through the simplification operation until the model achieves the optimal LOD. Once every component is simplified, the simplified components are reassembled and output to the final simplified 3D CAD assembly model.

2.2 Evaluation metrics

On the basis of the simplification criteria, the characteristic values of features are determined to select the features to be removed during simplification. The evaluation metrics should calculate the importance of each feature quantitatively and assign exclusive priority to features satisfying certain criteria

Fig. 1 Overall procedure for simplification of feature-based 3D CAD assembly models

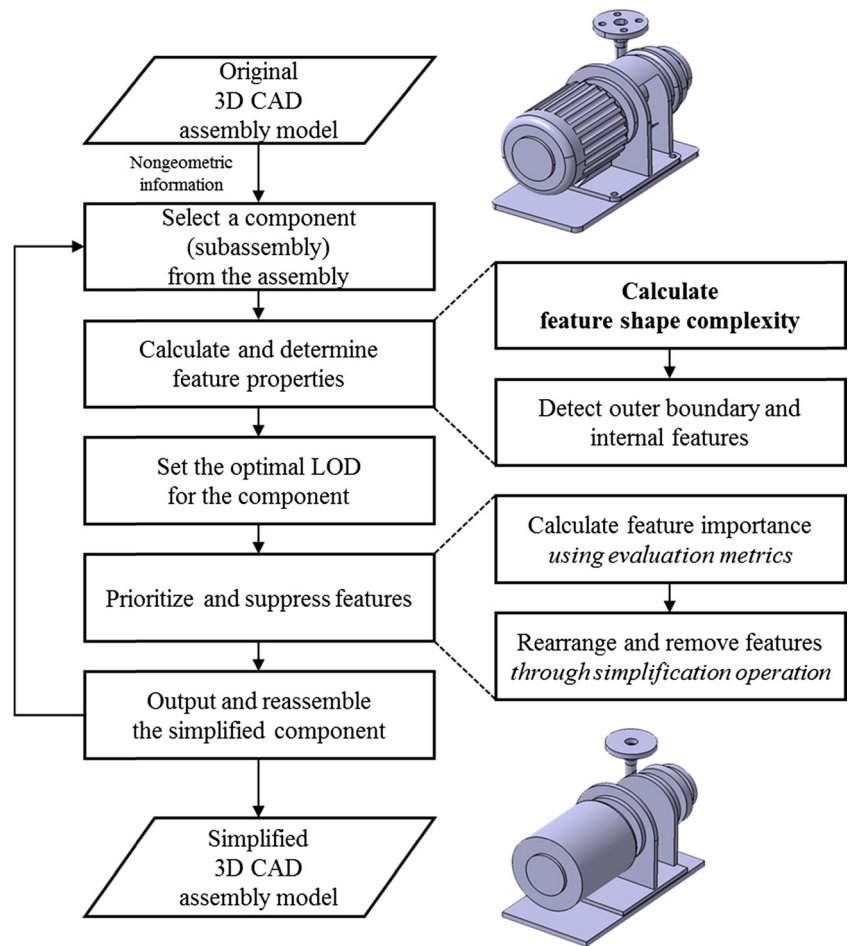

in order to either maintain or remove them. After the calculation, it is possible to simplify feature-based 3D CAD models through progressive LOD control.

Kang et al. [4] suggested evaluation metrics for the simplification of 3D CAD part models for ship outfitting and offshore plant equipment. They considered nongeometric information such as ports and outer boundaries. However, they did not consider exclusive priority for certain simplification criteria. Kwon et al. [7], on the other hand, proposed general evaluation metrics considering exclusive priority for simplifying feature-based 3D CAD models. In this study, the multicriteria evaluation metrics proposed in [7] are used for simplification. The evaluation metrics are defined as shown in Eq. (1).

$$FI_i = N_i(P_i + C_i)^{N_i} \tag{1}$$

where

$$P_i = \sum_x P_x^i, \text{ where } P_x^i = \begin{cases} 1 \\ 0 \end{cases} \tag{2}$$

$$C_i = \sum_x w_x C_x^i, \text{ where } \sum w_x = 1 \text{ and } 0 \leq C_x^i \leq 1. \tag{3}$$

$$N_i = \begin{cases} 1 \text{ if } \sum_x N_x^i = 0 \\ -1 \text{ if } \sum_x N_x^i \neq 0 \end{cases}, \text{ where } N_x^i = \begin{cases} 1 \\ 0 \end{cases} \tag{4}$$

FI_i is the importance of the i -th feature. The positive term P_i is a value corresponding to the features that must be maintained. In Eq. (2), x represents the name of a positive criterion. The conditional term C_i is a value retained by the features that correspond to the criteria for conditional simplification and is owned by all features. In Eq. (3), x represents the name of a conditional criterion. Here, users need to set weighting factors for each criterion if there are multiple criteria. The negative term N_i is a value corresponding to the features that must be removed. In Eq. (4), x represents the name of a negative criterion.

Equation (1) divides features into three ranges: those that must be preserved ($FI_i > 1$), those that are conditionally simplified ($0 < FI_i \leq 1$), and those that must be removed ($FI_i < 0$).

Hence, during simplification, the features can be progressively removed according to their relative importance.

In this study, ports, outer boundaries, and assembly constraints are chosen for the criteria P_i . FSC is newly adopted for the criteria C_i . Finally, internal features are selected for the criteria N_i . This study adopted the same criteria for P_i and N_i as those used by Kwon et al. [7]. However, unlike in the previous study, in which feature volume, port adjacency, outer boundary adjacency, and assembly constraint adjacency were chosen, in the present study, only FSC is used for C_i to verify its effectiveness. Users, therefore, do not need to input weighting factors for the various criteria of C_i .

2.3 Simplification operation

The term *simplification operation* denotes the operations required to remove features and obtain a simplified version of feature-based 3D CAD models. Most studies on the simplification of feature-based 3D CAD models involve the following two steps: feature rearrangement according to importance and removal of features with low importance up to the optimal LOD.

Lee et al. [6] proposed an algorithm to rearrange features by considering the effective volumes of features, and they applied the algorithm to simplify feature-based 3D CAD part models. Kwon et al. [7] proposed an algorithm for preserving the general connectivity of models using a feature adjacency graph (FG) to eliminate the possibility of models being separated during simplification. For example, a feature will not be removed if its presence is necessary to preserve connectivity even if it has very low importance. The algorithms were presented in both studies [6] and [7] were adopted for feature rearrangement and preservation of connectivity.

In addition to the core operations described earlier, studies have been conducted on detecting internal features to simplify feature-based 3D CAD models, and the concepts underlying these studies were basically similar. Kanai et al. [13] and Yu et al. [14] developed a method to detect the features that cannot be seen from every viewpoint by rendering models in the frame buffer from various viewpoints. Kwon et al. [1] detected internal features by firing rays from various viewpoints from inside and outside the models. The internal features should be removed first according to the criteria of the negative term in this study. Therefore, it is necessary to detect internal features, and the method proposed by Kwon et al. [1] is used in this study.

3 Feature shape complexity

FSC is a new concept developed as a criterion for the purpose of the simplification of feature-based 3D CAD models. It is a

quantitative value representing the complexity of the shape of each feature comprising a model. It is calculated as shown in Eq. (5):

$$FSC^i = \lambda \cdot (CV^i + CE^i) / FSC_{max} \quad (5)$$

where $0 < FSC^i \leq 1$,

$$\lambda = CV^i / CE^i. \quad (6)$$

CV^i and CE^i represent the volume complexity and element complexity of the i th feature comprising a 3D CAD model. The sum of the two types of complexity gives the importance of the features. The final FSC is determined after multiplying the sum by λ , which is the relative ratio of CV^i and CE^i , where the effect of CV^i is considered more important. For example, if two features have the same CV^i , the feature with the higher CE^i will be considered less important. In other words, removal of features with a higher CE^i will affect the data size of the original model to a greater extent. These types of complexity will be explained in Section 3.1 and Section 3.2.

3.1 Volume complexity

The volume complexity CV^i is calculated as shown in Eq. (7):

$$CV^i = (C_{BV}^i + C_{RV}^i) / CV_{max} \quad (7)$$

where $0 < CV^i \leq 1$,

$$C_{BV}^i = \begin{cases} (V_{BV}^i - V_{BV}^{i-1}) / V_{Final} & \text{if } V_{BV}^i \geq V_{BV}^{i-1} \\ 0 & \text{if } V_{BV}^i < V_{BV}^{i-1} \end{cases} \quad (8)$$

$$C_{RV}^i = V^i / V_{max}. \quad (9)$$

The boundary volume complexity (C_{BV}^i) represents the effect of the i th feature from the perspective of increasing the boundary volume of a model, and V_{Final} is the final volume of the model. Hence, only additive features are taken into account, and subtractive features are ignored. This is similar to the previous studies, where subtractive features were removed to preserve the original shape of models to the maximum extent possible [6].

The relative volume complexity (C_{RV}^i) is the ratio of the relative volume of all the features comprising the original model; V_{max} is the maximum volume of all the features. Unlike C_{BV}^i , C_{RV}^i considers both the additive and subtractive features.

Figure 2 shows an example of the volume complexities of features with the modeling order. The additive feature (F_1) has a higher CV^i than the subtractive feature (F_2) when the two features have the same volume. This trend helps preserve the boundary volume of the model during simplification.

Fig. 2 Modeling sequence and corresponding volume complexity of features

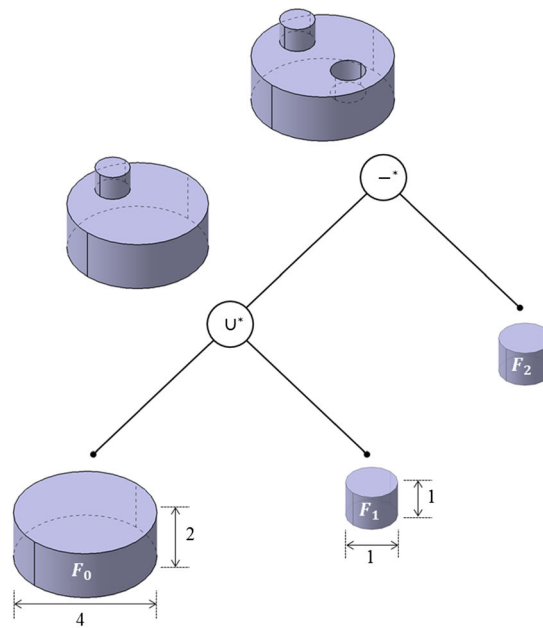

Feature	Type	Volume (V^i)	Bounding volume complexity (C_{BV}^i)	Relative volume complexity (C_{RV}^i)	Volume complexity (CV^i)
F_0	+	$V^0 = V_{max} = 8\pi$	$V^0/V_{Final} = 1$	$V^0/V_{max} = 1$	$2/2 = 1$
F_1	+	$V^1 = 0.25\pi$	$V^1/V_{Final} = 0.03125$	$V^1/V_{max} = 0.03125$	$0.0625/2 = 0.03125$
F_2	-	$V^2 = V^1 = 0.25\pi$	0	$V^2/V_{max} = 0.03125$	$0.03125/2 = 0.015625$

3.2 Element complexity

The element complexity CE^i is calculated as shown in Eq. (10). $U(x)$ is defined as the total number of data units required for defining a geometric type x . The number of data units is represented as a real number. CE^i becomes higher when a feature has a larger number of elements with a higher $U(x)$. Three features shown in Fig. 2 have the same CE^i because all three features are cylindrical with the same number of surfaces and curves.

$$CE^i = (C_S^i + C_C^i) / CE_{max} \tag{10}$$

where $0 < CE^i \leq 1$,

$$C_S^i = \sum_{j=1}^n U(s^j) \tag{11}$$

where $s^j \in S$, $S = \{\text{Plane, Cylinder, Sphere, Cone, Torus, and Spline Surface}\}$,

$$C_C^i = \sum_{j=1}^m U(c^j) \tag{12}$$

where $c^j \in C$, $C = \{\text{Straight Line, Circle, Ellipse, Helix, and Spline}\}$.

The surface complexity C_S^i is defined as the total number of data units required to define all the surfaces constructing a feature. For example, a plane is defined by an origin (x_1, y_1, z_1) and a direction (x_2, y_2, z_2) , which leads to $U(\text{Plane})=6$ (Fig. 3a). A cylinder is defined by an origin (x_1, y_1, z_1) , a direction (x_2, y_2, z_2) , and a radius (r), which leads to $U(\text{Cylinder})=7$ (Fig. 3b).

The curve complexity C_C^i is defined as the total number of data units required to define all the curves constructing a feature. For example, a straight line is defined by a start point (x_1, y_1, z_1) and an end point (x_2, y_2, z_2) , which leads to $U(\text{Straight Line})=6$ (Fig. 3c). A circle is defined by a center point (x_1, y_1, z_1) , a start point (x_2, y_2, z_2) , an end point (x_2, y_2, z_2) , and a radius (r), which leads to $U(\text{Circle})=10$ (Fig. 3d).

The types of geometric element and data unit for each geometric type were determined by referring to the data structure of 3D ACIS Modeler [19], a commercial 3D geometric modeling kernel developed by Spatial Corporation. For the calculation of element complexity, the plane, cylinder, sphere, cone, torus, and spline surface are considered as surface types, and the straight line, circle, ellipse, helix, and spline are considered as curve types. Other types of curve and surface such as

Fig. 3 Required data units for defining **a** plane, **b** cylinder, **c** straight line, and **d** circle

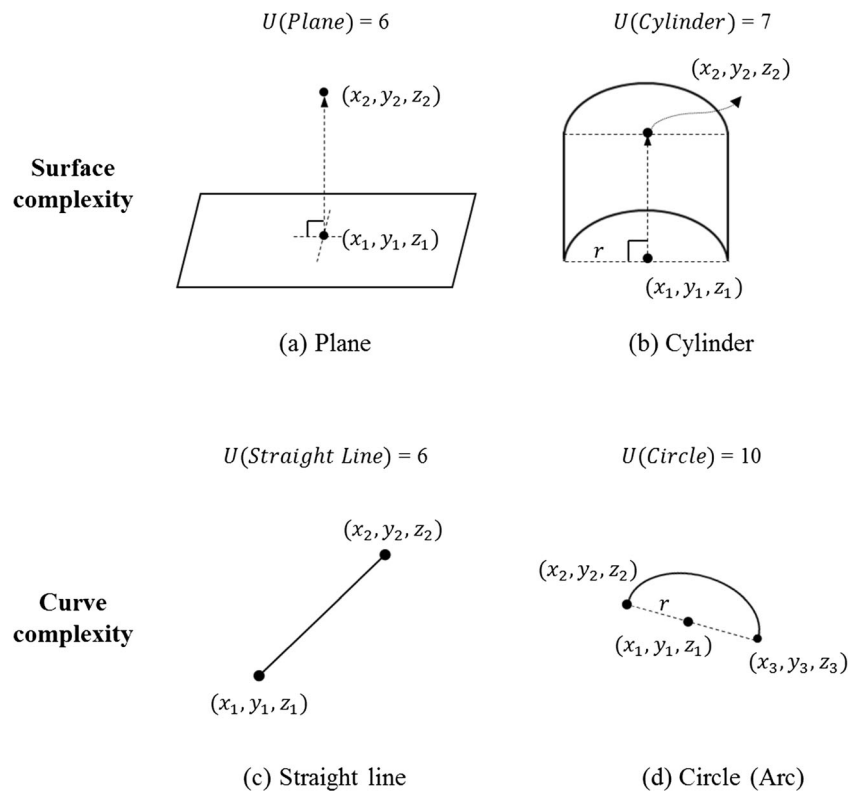

interpolated curves, which are not considered at present, can also be included if necessary only when input data for each geometric type are quantified in the form of data units.

Figure 4 shows a comparison of the CE^i of two hexahedral features. F_0 consists of six planes and 12 straight lines, and F_1 consists of four planes, two cylindrical surfaces, eight straight lines, and four arcs. Therefore, F_0 has a smaller CE^i than F_1 . Suppose these features have the same volume. Then, the FSC of the features will be $FSC^0 = (1/0.831)(1 + 0.831) = 2.203$ and $FSC^1 = (1/1)(1 + 1) = 2$ (i.e., $FSC^0 > FSC^1$). Hence, F_1 will be removed first, because a feature with a higher CE^i affects the data size of the original model to a greater extent. The

introduction of FSC is closely related to the main purpose of research on simplification, where the aim is to preserve the outer shape of the original model and minimize the data size simultaneously.

Table 1 lists all the criteria considered in the evaluation metrics and algorithms adopted in this study. This table also clarifies whether the criteria and algorithms are applied to additive or subtractive features, or to both. P_i typically considers additive features such as ports and outer boundaries because it is assigned to the features that must be preserved. C_{BV}^i too considers only additive features because it concerns the effect on the boundary volume of a model. Only additive

Fig. 4 Element complexities of two similar features

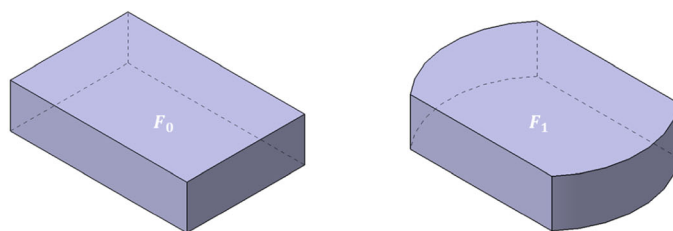

Feature	Surface complexity (C_s^i)	Curve complexity (C_c^i)	Element complexity (CE^i)
F_0	$6 \times U(\text{Plane}) = 36$	$12 \times U(\text{Straight Line}) = 72$	$108/130 = 0.831$
F_1	$4 \times U(\text{Plane}) + 2 \times U(\text{Cylinder}) = 42$	$8 \times U(\text{Straight Line}) + 4 \times U(\text{Circle}) = 88$	$130/130 = 1$

Table 1 Simplification criteria and their considerations of additive and subtractive features

				Additive features	Subtractive features
Evaluation metrics	P_i			O	X
	$C_i (=FSC^i)$	CV^i	C_{BV}^i	O	X
			C_{RV}^i	O	O
			CE^i	O	O
			C_C	O	O
Simplification operations	N_i			O	O
	Connectivity preserving algorithm			O	X
	Feature-rearranging algorithm			O	O

(O considered, X not considered)

features have an impact on the connectivity of a model, and hence, the connectivity preserving algorithm considers only additive features [7]. The rest of the criteria and the algorithm consider both additive and subtractive features.

4 Implementation and experiments

4.1 Prototype system implementation

A prototype system was implemented to verify the proposed method. The system was implemented on the Windows 7 platform with the C++ language. It used ACIS R25 [19] as a geometric modeling kernel, HOOPS 1919 [20] as a 3D visualization engine, and Boost Graph Library (BGL) [21] as a graph data management library to create the FG in the connectivity preserving algorithm.

The configuration of the prototype system is shown in Fig. 5. The 3D CAD model manager manages the data structure of features, components, and assemblies. The engine

controls the FSC calculation, internal feature detection, feature rearrangement, and LOD management. The connectivity manager creates the FG and preserves the model’s connectivity during simplification.

The engine layer includes the main functions of the system for calculating the importance of features and simplifying the model. The system imports and exports data through the data processing layer. Neutral formats (XML [22] and STEP AP203 [23]) are used as input and output information (3D CAD part and assembly models and additional nongeometric information). The geometry processing layer processes geometric data and visualizes the data.

4.2 Experimental results

For the experiments using the prototype system, a fresh water unit (FWU) model was used. It was modeled as a 3D CAD assembly model using the commercial CAD system CATIA V5 R22. The FWU model has seven components: three sub-assemblies and four parts (Fig. 6). Users enter the desired

Fig. 5 Configuration of the prototype 3D CAD model simplification system

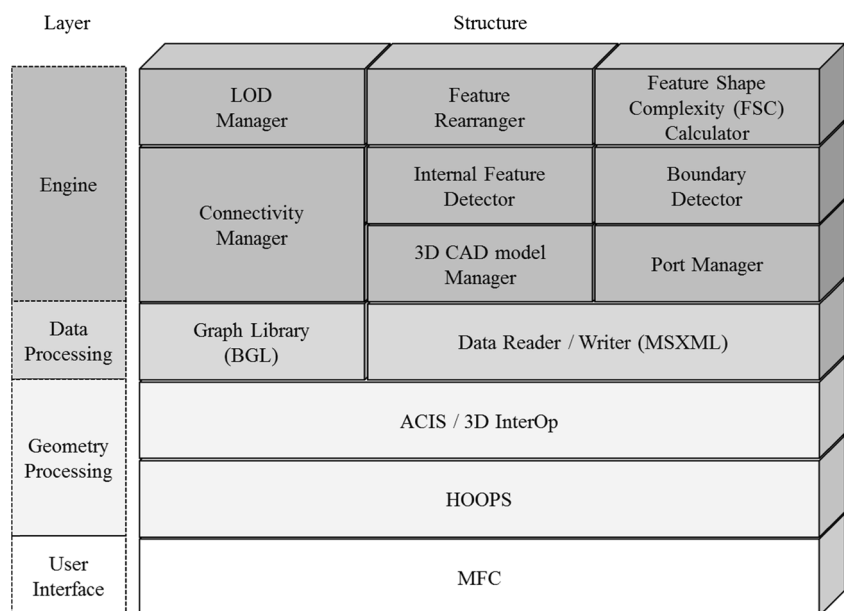
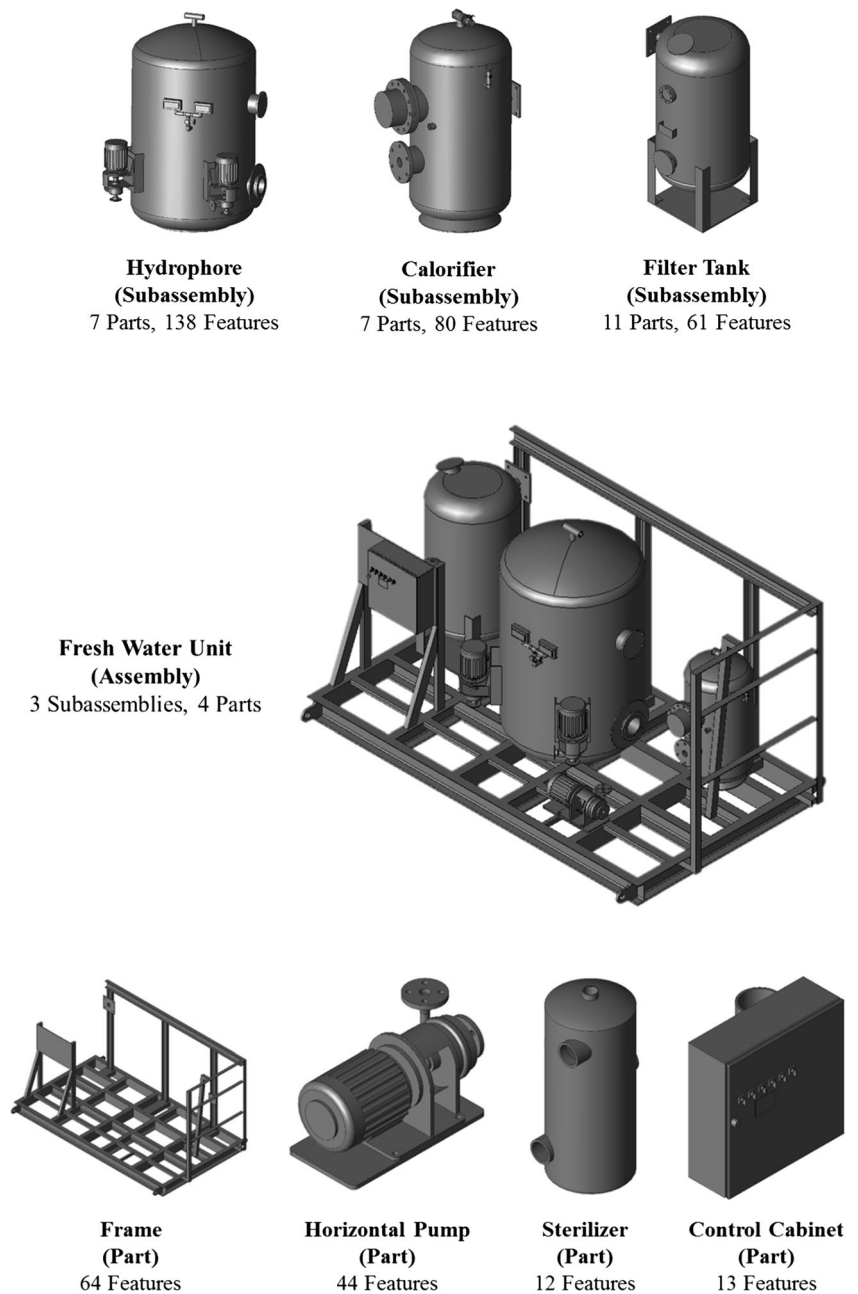

Fig. 6 Test case for experiments (the fresh water unit and its components)











LOD for each component and simplify each component after importing the model on the system. The final simplified model can be created by reassembling all the simplified components.

Tables 2 and 3 present a comparison of volume-based and FSC-based simplification in terms of the simplified shapes, LODs, and data sizes for the subassembly and part components. Simplified models were exported in the STEP AP203 (.stp) format. The optimal LOD for each component was decided by the users such that the number of features comprising the component is decreased to a lower value as possible while the change in the outer shape of the model is minimized.

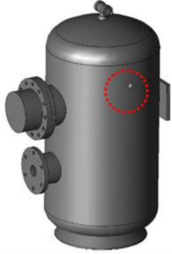
The major differences in shape between the two simplification methods are indicated by red circles in the tables. FSC-based simplification preserved the outer characteristics of the original shape to a greater extent. This is because additive features are retained longer in the case of FSC-based simplification. Meanwhile, subtractive features were retained longer in the case of volume-based simplification because only additive feature had a positive value of C_{BV}^i . Hence, in FSC-based simplification, features with small volume and high complexity, such as holes and edge fillets, were removed early, at the beginning of the simplification.

Table 2 Simplification results for subassemblies

	Original model	Simplified model	
		FSC-based	Volume-based
Hydrophore			
LOD	100	30	
Data size	1 114	332	530
Calorifier			
LOD	100	35	
Data size	716	210	310
Filter tank			
LOD	100	35	
Data size	3 069	511	517







The data sizes were decreased to 30, 29, and 17 % for each subassembly and 30, 54, 10, and 75 % for each part; these values correspond to about 35 % of the original data size on an average. The data size of a 3D CAD model is usually proportional to the number of modeling elements in the polygon-based or b-rep-based model. However, the data size of a feature-based model is not exactly proportional to the LOD, as seen from the results. This is because the LOD stands for the number of features in feature-based simplification, and each feature affects the total data size differently.

The optimal LOD of the frame model in Table 3 is rather higher than the optimal LODs of the other models. The reason is as follows. First, simple features such as extrusions and revolutions, not complex features such as edge fillets and chamfers, were mainly used when creating the frame model.

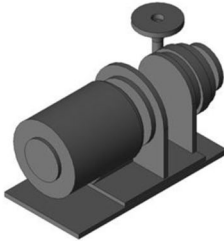
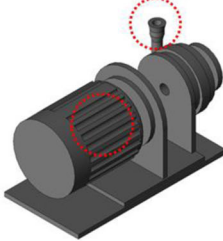
Second, most of the features are located on the outer boundary of the model. It is, therefore, difficult to remove these features, because outer shape preservation is an important requirement for the installation and maintenance of equipment in the process plant industry. Hence, the user had to stop simplification after all the subtractive features were removed. Thus, the optimal LOD varied depending on the context or usage of each model in the domain.

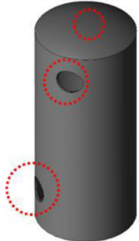
Table 4 presents a feature list, feature volumes, FSCs, and the corresponding ranking of the sterilizer part component. The last column shows the ranking difference between volume-based and FSC-based simplifications. The ranking of the subtractive features dropped in the case of FSC-based simplification because of the effect of *CV*. Further, *EdgeFillet.1* had the smallest volume and the second highest

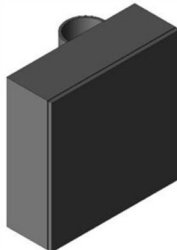
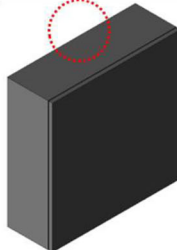
Table 3 Simplification results for part components

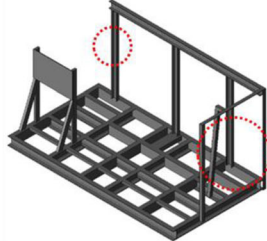
	Original model	Simplified model	
		FSC-based	Volume-based
Horizontal pump			
LOD	100	45	
Data size	354	107	221
Sterilizer			
LOD	100	50	
Data size	99	54	72
Control cabinet			
LOD	100	30	
Data size	305	31	33
Frame			
LOD	100	70	
Data size	1 686	1 260	1 259

CE value. Transition features such as edge fillets usually have a high *CE* and are very small because they create surfaces and curves on the model. Hence, among features with similar volumes, the transition features are removed first. In the area of engineering analysis, designers tend to remove transition features to reduce the analysis time. FSC-based simplification is

more suited for making models for engineering analysis because transition features are less important in this case than in volume-based simplification.

Figure 7 shows the changes in data size as the LOD of hydrophore and horizontal pump models decreased. The data size of the FSC-based simplified model was lower than that

Table 4 Feature list and corresponding rankings of the sterilizer part component

Feature	Type	V^i	CV^i	CE^i	FSC^i	Ranking (V^i)	Ranking (FSC^i)	Ranking diff.
Pad.1	+	8,157,485	1	0.2708	1	1	1	0
Pocket.5	−	6,933,033	0.1063	1	0.02507	2	2	0
Shaft.1	+	143,413	0.01758	0.2222	0.004043	3	3	0
Pocket.4	−	138,544	0.002125	0.2708	0.0004563	4	7	−3
Pocket.2	−	130,232	0.001997	0.2708	0.0004287	5	8	−3
Pocket.3	−	130,232	0.001997	0.2708	0.0004287	5	8	−3
Pad.2	+	38,104	0.004671	0.2917	0.001011	7	4	3
Pad.3	+	38,104	0.004671	0.2917	0.001011	7	4	3
Pad.5	+	33,263	0.004078	0.2917	0.0008811	9	6	3
Pocket.1	−	11,451	0.0001756	0.2708	0.00003745	10	11	−1
Pad.4	+	8511	0.001043	0.3403	0.000223	11	10	1
EdgeFillet.1	−	2795	0.00004286	0.3542	0.000009136	12	12	0

achieved in volume-based simplification in almost every LOD range, except when the LOD was below 20 %. This is because features with higher complexity were removed in the early stages of simplification.

Figure 8 shows a comparison of the original and the simplified 3D CAD assembly models. The final simplified model has 40 % of the LOD and 52 % of the original data size. The data size also shows a lower decreasing rate unlike those of other components. The main reason for the lower decreasing rate is that the frame model cannot be sufficiently simplified compared to other subassemblies and parts because most features comprising the frame model are simple features located at the outer boundary. However, the overall characteristics of the original shape are well preserved after simplification.

4.3 Application fields of the model simplification technology

The design of a product consisting of a large number of parts and subassemblies becomes possible with the advances in information technology. Nevertheless, there are still certain limitations in processing the product with the advanced computer hardware [24]. Therefore, 3D CAD model simplification

has a number of applications in the areas of engineering analysis, manufacturing simulation, and product design [7].

The computational time for the engineering analysis depends on the number and complexity of the geometric elements contained in the 3D CAD model. Local features including fillets, chamfers, and holes do not have a critical impact on the analysis result and lead to an increase in computation power and time. Therefore, local features should be removed.

The needs for digital manufacturing have steadily grown in order to reduce the cost for the preparation of actual manufacturing. To build a digital factory, 3D CAD models for all the production equipment and facilities should be prepared. Detailed features of a 3D CAD model are not necessary because they have no critical impact on the manufacturing simulation result and increase the computation power and time. Therefore, 3D CAD models for production equipment and facilities should be simplified.

In the process plant and shipbuilding industries, EPC companies and equipment manufacturers use 3D CAD models with different LODs. Equipment manufacturers use 3D CAD models with a high LOD to design and produce equipment. On the other hand, EPC companies need 3D CAD models with a low LOD because they are interested in placing

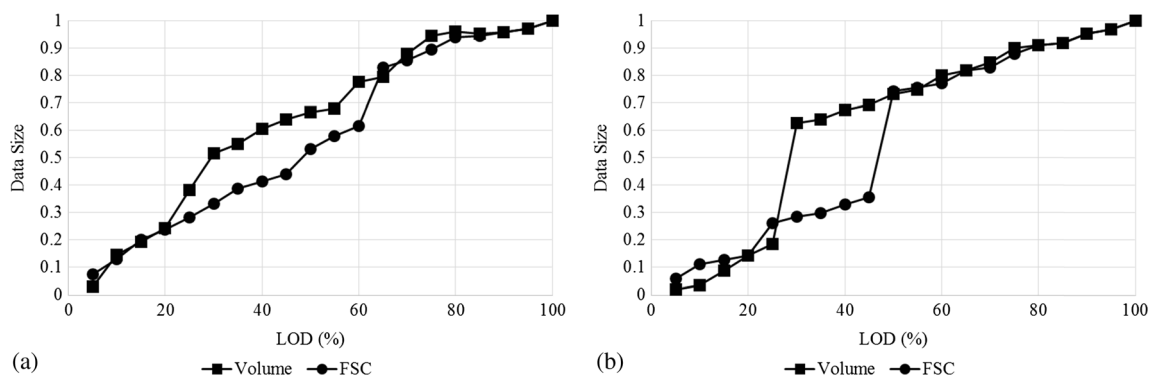
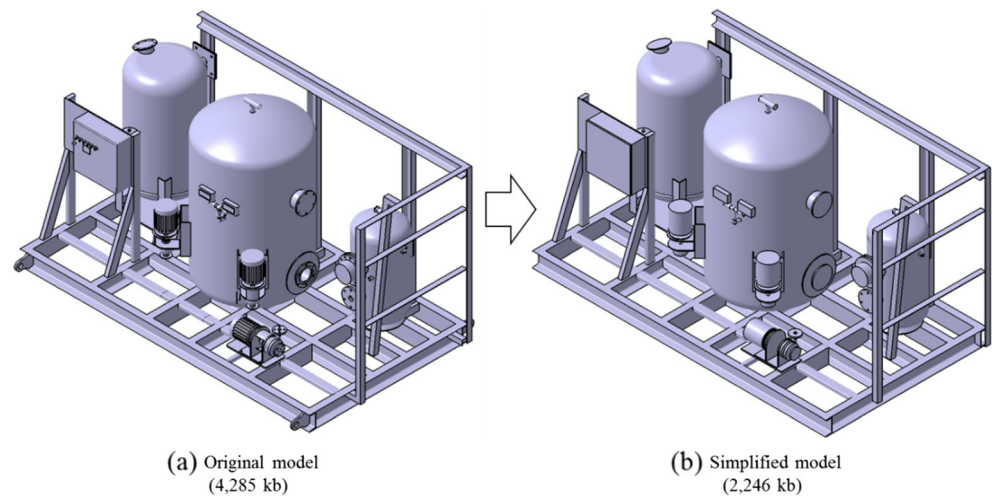

Fig. 7 Decrease in data size during simplification. **a** Hydrophore. **b** Horizontal pump model

Fig. 8 Final simplification result of the fresh water unit model



and assembling equipment to construct process plants or ships. Therefore, 3D CAD models of equipment supplied by manufacturers should be simplified for EPC companies.

5 Discussion and conclusion

The required LOD for 3D CAD models depends on the purpose of the models. Hence, simplification techniques that enable users to control the LOD automatically are necessary. For the simplification of feature-based 3D CAD models, the evaluation metrics and the simplification operation along with the simplification procedure were first explained. FSC, which comprises volume complexity and element complexity, was then introduced; new evaluation metrics were proposed considering FSC as a conditional term. A prototype system for simplification was developed for verifying the proposed evaluation metrics, and simplification experiments for feature-based 3D CAD assembly data were described.

The results of FSC-based simplification were much better than those of volume-based simplification at the same LOD; the data size of the FSC-based simplified model was lower than that achieved in volume-based simplification. From the experiments, FSC is expected to be widely used as a general and effective criterion for simplifying feature-based models.

In the experiments, the data sizes were decreased to 30, 29, and 17 % for each subassembly and 30, 54, 10, and 75 % for each part. The optimal LOD for each component was decided by the users such that the number of features comprising the component is decreased to a lower value as possible while the change in the outer shape of the model is minimized. However, further reduction in data size for the 3D CAD model would be required depending on its purpose. In this case, generation of a lightweight 3D CAD model [25] from the simplified 3D CAD model needs to be considered.

The determination of the optimal LOD for each model is still an unsolved problem. A quantitative indicator that can represent the goodness or badness of the simplification results can help users choose the optimal LOD. Therefore, it is necessary to develop a method to determine the optimal LOD range by considering several factors such as shape similarity and data size.

Acknowledgments This research was supported by the Plant Research Program (Project ID: 14IFIP-B091004-01) funded by the Ministry of Land, Infrastructure and Transport, by the Industrial Core Technology Development Program (Project ID: 10063452) funded by the Ministry of Trade, Industry and Energy, and by the Human Resources Development program (Project ID: 20134030200300) funded by the Ministry of Trade, Industry and Energy of the Korean government. The authors gratefully acknowledge their support.

References

1. Kwon S, Kim BC, Mun D, Han S (2015) Simplification of feature-based 3D CAD assembly data of ship and offshore equipment using quantitative evaluation metrics. *Comput Aided Des* 59:140–54
2. Foucault G, Cuilliere JC, Francois V, Leon JC, Maranzana R (2008) Adaptation of CAD model topology for finite element analysis. *Comput Aided Des* 40(2):176–96
3. El-Sana J, Varshney A (1998) Topology simplification for polygonal virtual environments. *IEEE Trans Vis Comput Graph* 4(2):133–44
4. Kang Y, Kim BC, Mun D, Han S (2014) Method to simplify ship outfitting and offshore plant equipment three-dimensional (3-D) computer-aided design (CAD) data for construction of an equipment catalog. *J Mar Sci Technol* 19(2):185–196
5. Date H, Kanai S, Kisinami T, Nishigaki I, Dohi T (2005) High-quality and property controlled finite element mesh generation from triangular meshes using the multiresolution technique. *J Comput Inf Sci Eng* 5(4):266–76
6. Lee SH, Lee K (2012) Simultaneous and incremental feature-based multiresolution modeling with feature operations in part design. *Comput Aided Des* 44(5):457–83

7. Kwon S, Kim BC, Mun D, Han S (2015) Graph-based simplification of feature-based three-dimensional computer-aided design models for preserving connectivity. *J Comput Inf Sci Eng* 15(3): 90–103
8. Hoppe H (1996) Progressive meshes. *Proc ACM SIGGRAPH*. doi: [10.1145/237170.237216](https://doi.org/10.1145/237170.237216), 99–108
9. Sheffer A (2001) Model simplification for meshing using face clustering. *Comput Aided Des* 33(13):925–34
10. Huang P, Wang C (2010) Volume and complexity bounded simplification of solid model represented by binary space partition. *Proceedings of the 14th ACM Symposium on Solid and Physical Modeling*, 177–82
11. Kim BC, Mun D (2014) Stepwise volume decomposition for the modification of B-rep models. *Int J Adv Manuf Technol* 75(9–12): 1393–403
12. Seo JH, Song YJ, Kim SC, Lee KW, Choi Y, Chae SW (2005) Wrap-around operation for multi-resolution CAD model. *Comput Aided Des Appl* 2(1–4):67–76
13. Kanai S, Iyoda D, Endo Y, Sakamoto H, Kanatani N (2012) Appearance preserving simplification of 3D CAD model with large-scale assembly structures. *Int J Interact Des Manuf* 6(3): 139–54
14. Yu JF, Xiao H, Zhang J, Cheng H, Xin B (2013) CAD model simplification for assembly field. *Int J Adv Manuf Technol*. doi: [10.1007/s00170-013-4850-z](https://doi.org/10.1007/s00170-013-4850-z)
15. Wikipedia (2015) <https://en.wikipedia.org/wiki/Complexity>
16. Rodriguez-Toro C, Tate S, Jared G, Swift K (2002) Shaping the complexity of a design. *Proc IMECE* 2002:641–9
17. Pellerin J, Gaumon G, Julio C, Mejia-Herrera P, Botella A (2015) Elements for measuring the complexity of 3D structural models: connectivity and geometry. *Comput Geosci* 76(14):130–40
18. Valentan B, Brajlili T, Drstvenšek I, Balič J (2011) Development of a part-complexity evaluation model for application in additive fabrication technologies. *J Mech Eng* 57(10):709–18
19. 3D ACIS Modeler (2013) Spatial. <http://www.spatial.com/products/3d-acis-modeling>
20. HOOPS Visualize (2015) Tech Soft 3D. <http://www.techsoft3d.com/products/hoops-toolkits/hoops-visualize>
21. The Boost Graph Library (BGL), Indiana University (2013) http://www.boost.org/doc/libs/1_54_0/libs/graph/doc
22. XML technology. W3C. <http://www.w3.org/standards/xml>
23. ISO (1994) ISO 10303–203 1994. Industrial automation systems and integration—product data representation and exchange—part 203: application protocol: configuration controlled 3D designs of mechanical parts and assemblies. Geneva, Switzerland: International Organization for Standardization. ISO
24. Sun G (2007) A digital mock-up visualization system capable of processing giga-scale CAD models. *Comput Aided Des* 39(2):133–141
25. Song IH, Chung SC (2009) Data format and browser of lightweight CAD files for dimensional verification over the internet. *J Mech Sci Technol* 23(5):1278–1288