

Review: geometric and dimensional tolerance modeling for sheet metal forming and integration with CAPP

Wang Rui · Georg Lothar Thimm · Ma Yongsheng

Received: 14 May 2008 / Accepted: 7 April 2010 / Published online: 25 April 2010
© Springer-Verlag London Limited 2010

Abstract The focus of this publication is a review of the state of the art in tolerance analysis, synthesis, and transfer for geometric and dimensional tolerances in sheet metal forming and the integration solutions with computer-aided process planning systems. In this context, the general tolerance methods are first described. Then, the mathematical models for sheet metal tolerance analysis and synthesis are examined in detail. To address the CAPP modeling concerns, the paper is then followed up with a brief review of past research works related to feature-based process planning. Finally, those imperative future research areas are identified.

Keywords GDT · Tolerance transfer · Geometric tolerances · Sheet metal · Process planning

1 Introduction

Sheet metal forming (SMF) is one of the most common manufacturing methods for metal parts and is used widely in industries [99]. As in assembly or metal removal

processes, design and process tolerances play an important role with respect to functionality and cost. However, mathematical methods for tolerance analysis, synthesis, and transfer used in non-sheet metal forming processes are not readily applicable. Reasons are the differences between sheet metal forming and conventional material removal machining as summarized in Table 1.

Great advances have been made in the field of sheet metal forming. New processes and working methods have been developed. Many tools for design, process simulation, and control are available today [2, 4, 86, 101, 138, 148, 149, 159, 189, 190, 218, 238, 243, 257]. Since the 1990s, due to the rapidly diminishing number of experienced process planners for SMF, the need for shorter product life cycles and the importance of three-dimensional (3D) computer-aided design and manufacturing (CAD/CAM), the research on process planning in this area attracted more attention. The research areas cover topics such as raw material preparation technologies, process selection, tooling design, operation sequencing, fixture definition, and collision detection [69, 170].

Problems related to tolerances emerge in several stages of the life cycle of a sheet metal part. The problems are characterized by the particular viewpoints and objectives of the individual life cycle stages. For example, a process planner has to find the most economical processes and their sequence as well as to fulfill the tolerance specification in product design. For machined parts, tolerance constraints play a significant role in process planning, and computer-aided tolerancing (CAT) has been developed as a key technology for determining machining sequences that can result in the best accuracy on some special features of parts [102, 125, 260]. However, in sheet metal forming, currently, an effective approach of computer-aided tolerance analysis is still not fully developed, and hence, there is no comprehensive method to integrate design and process planning.

W. Rui · G. L. Thimm
School of Mechanical and Aerospace Engineering,
Nanyang Technological University,
Singapore, Singapore

W. Rui
e-mail: wang0087@ntu.edu.sg

G. L. Thimm
e-mail: mgeorg@ntu.edu.sg

M. Yongsheng (✉)
Department of Mechanical Engineering, University of Alberta,
Edmonton, AB T6J 6S8, Canada
e-mail: yongsheng.ma@ualberta.ca

Table 1 Comparison of SMF and conventional machining methods (modified from [95])

Sheet metal forming	Conventional material removal machining process
The initial parts or blanks are cut out to form the required shape from a large sheet metal layout.	The initial raw work-piece is normally sawed, preformed, or prepared by casting or forging process. They are less precise than sheet metal blanks.
The process is irreversible. Once formed incorrectly, parts are scrap.	Work-piece can be machined again if the machined work piece is not undersized (it usually is scrap otherwise).
Surface finish depends on the forming process.	Surface finish largely depends on the final machining operation.
The deformation usually causes significant changes in shape, but not in cross-section (sheet thickness and surface characteristics) of the sheet.	The cross-section in all orientations is potentially changed.

The organization of this review is that, at first, sheet metal forming operations are surveyed, in which bending and punching operations are emphasized; then, the past research efforts on CAT are reviewed; and finally followed by the discussion of its integration with computer-aided process planning (CAPP) aspect.

2 Sheet metal forming processes

Common sheet metal fabrication techniques include a multitude of different operations. These operations can be classified as in Table 2. Bending and punching are the most popular sheet metal forming processes. Some operations, such as folding, flanging, and hemming, may be regarded as bending-like operations because they have similar forming principles.

2.1 Bending operations

Bending is a prevalent type of forming operation, which provides the required shape and further rigidity to sheet metal parts. In this process, usually, a plane sheet or a metal strip is deformed in a circular arc around a straight axis lying perpendicular to the neutral axis as defined in [179]. Metal flow takes place in the plastic range of the metal so that the bent part retains a permanent set after removal of the applied stress. The cross-section of the bend inward from the neutral axis is in compression, and the rest of the bend is in tension [181]. The tensile stress decreases toward the center of the sheet thickness and becomes zero at the

neutral axis, whereas the compressive stress increases from the neutral axis toward the inside of the bend.

A typical sheet metal bending operation involves mounting a punch (punches) and mold (die) on a press, which controls relative motions between the punch and die, then, placing sheet metal on a die against a (auto-) stopper block, or a gage, to position the part. Punch(-es) and the mold (die) provide the necessary bending forces or pressures. Sometimes, grippers are used to hold the part during and between operations.

Bending processes fall into several categories: air bending, bottom bending, coining, U-bending, etc. Air bending is a bending process in which the punch forces the work piece into a V-shaped die and the work piece does not touch the bottom of the die. Bottom bending is a bending process where the punch and the work piece bottom on the die. Coining is a bending process in which the punch and the work piece bottom on the die and compressive stress is applied to the bending region to increase the amount of plastic deformation.

2.1.1 Bend allowance

If the bend radius is comparable to the thickness of the sheet, the sheet tends to stretch during bending. This influences the accuracy of dimensions and tolerances of final part and has to be reflected in the working dimensions. This change in length is compensated by the so-called bend allowance (*BA*), which can be estimated as follows:

$$BA = 2\pi \frac{\alpha}{360} (R + K_{ba}T) \quad (1)$$

Table 2 Common operations on sheet metal parts

Cutting operations	Bending operations
Punching, notching, shearing, blanking, drilling, piercing, nibbling, slitting, trimming, shaving, and stamping	Air bending, coining, bottoming, hemming, folding, and flanging
Joining operations	Other operations
Welding, soldering, bonding, riveting, screwing, and seaming	Drawing, rolling, stretching, spinning, and flattening

where BA =bend allowance, in millimeters; α =bend angle, in degrees; R =bend radius, in millimeters; T =material thickness, in millimeters; and K_{ba} is factor of stretching effect. K_{ba} is defined as t/T , where t is distance from the inside face to the neutral axis. Clearly, K_{ba} is a ratio that gives the location of neutral axis with respect to the thickness of the sheet metal part. The value of K_{ba} is usually estimated by adopting some recommended design values. Many CAD programs calculate the bend allowance by using K_{ba} (or Y-factor in the case of Pro-E, where the Y-factor is $\frac{K_{ba}T}{2}$) [85]. For air bending, bottom bending, and coining, [60] presented a method to determine K_{ba} reversely. Publications on bending allowances are numerous, and two recent ones are given in [116, 217].

2.1.2 Springback

When the bending pressure is removed, elastic energy in the bent part causes it to recover partially toward its original shape. This elastic recovery is called *springback*, defined as the increase in included angle of the bent part relative to the included angle of the forming tool after the tool is removed. This is expressed as:

$$\text{Springback} = \frac{\alpha_f - \alpha_i}{\alpha_i} = \frac{R_f - R_i}{R_i} \quad (2)$$

where α_f is the bending angle after springback in degrees; α_i is the bending angle before springback in degrees; R_f is the final bend radius after springback; R_i is the bend radius before springback.

Springback should be predicted in bending operations and the punch position adjusted accordingly. As it causes changes in shape and dimensions, springback prediction is an important issue. It is difficult for design engineers to predict springback, as many variables influence it: material variations in mechanical properties, tool geometry (including die radius and the gap between the die and the punch), sheet thickness, punch stroke, lubricant condition, etc. Springback is often approximated using

$$\frac{R_i}{R_f} = 4 \left(\frac{R_i Y}{ET} \right)^3 - 3 \left(\frac{R_i Y}{ET} \right) + 1, \quad (3)$$

where R_f is the final bend radius after springback in millimeters; R_i is the bend radius before springback in millimeters; Y is the yield strength of the sheet metal in megapascal; E is Young's modulus of the sheet metal in gigapascal; and T is the thickness of the sheet material.

For air bending, the springback usually ranges from 5 to 10°. Bottom bending and coining allow for a better control of the bending angle as springback is reduced.

Various investigations show the influence of process parameters on springback, such as bend radius, die gap, and

punching speeds, and material properties, such as sheet thickness, flow stress, texture, and grain size [26, 42, 114, 129].

2.2 Punching

Punching is a very efficient, inexpensive, and flexible way of producing cutouts from sheet metal. The term punching describes a shearing process, in which a punching machine separates a sheet of metal by striking it, while supporting it by a die with a hole matching the cross-section of the punch. In punching, the cut out part of sheet is scrap, and the remaining material is a desired part. Opposed to it, in blanking, the cut out section of the part is the required part.

Punching is usually utilized to create holes of various shapes in sheet metal material. Traditional punching operations produce a single geometry with the same tool. numerically controlled (NC) punching operations with multiple standard tools can produce a wide range of geometries characterized by simple geometrical elements like lines and circles [181].

2.3 The “other” forming operations

The forming operations listed under “others” in Table 2 are not addressed in detail in this report. In brief, they either produce

- plain, flat sheet metal, and only thickness tolerance matters, or
- free-form surfaces for which all tolerances are defined by the drawing process (and estimated by finite element methods, for example)

3 Computer-aided tolerancing

Tolerances and tolerance-related problems play a ubiquitous role in both product design and process planning. The existing research can be classified into seven distinct categories as in Fig. 1. Selected tolerancing methods are discussed later. In this figure, the dashed lines indicate that tolerance transfer techniques are derived from tolerance analysis and tolerance synthesis, as explained later in section 3.4.

3.1 Geometrical dimensioning and tolerancing

Two main types of tolerancing schemes are in use: parametric and geometrical. Parametric tolerancing identifies a set of design parameters and assigns limits or distributions to the parameters, such as maximal deviations (conventional \pm) or statistical tolerances [175]. A recently

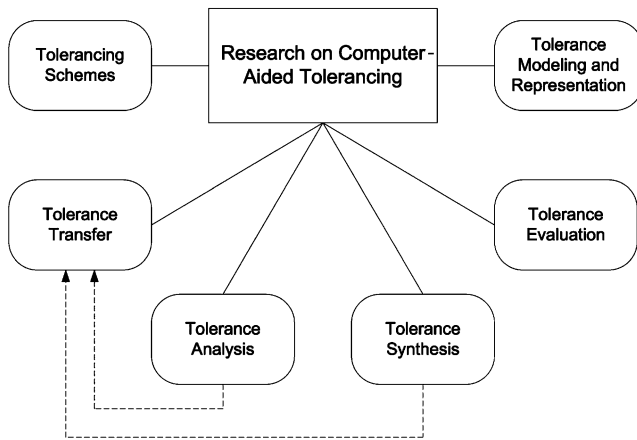

Fig. 1 Research on computer-aided tolerancing [98]

proposed tolerancing scheme called vectorial tolerancing falls into this category [247].

Defined in ISO 1101 and ANSI Y14.15M:1994, Geometrical Dimensioning and Tolerancing is a dimensioning system that benefits both design engineering and manufacturing engineering. It allows designers to set tolerance limits, not just for the size of an object, but also for all of the critical characteristics of a part.

Geometrical tolerances describe the acceptable range of variation in geometry from a nominal or reference geometry. They designate values to certain characteristics of features, such as form, orientation, location, and run-out. Detailed explanation and examples of current standards on geometrical dimensioning and tolerancing can be found in ANSI Y14.15M:1994 or ISO specifications such as ISO 1101:2002, ISO 14660-1:1999, and ISO/TS 17450-1:2005.

Orientation and position tolerances are often used in sheet metal parts. Orientation tolerances include perpendicularity, parallelism, and angularity tolerances, as shown in Fig. 2. Discussions of geometrical error evaluation and related research work can be found in [155, 179, 180, 193–196, 232, 233]. The methods are mainly based on CMM, computational geometrical techniques, and artificial intelligence (AI).

3.2 Tolerance analysis

Tolerance analysis is used to estimate the accumulation of process variations on assembly dimensions and features and to verify the proper functionality of a design. This topic has drawn considerable attention, and many papers have been published on 1D, two-dimensional (2D), and 3D tolerancing.

The analysis methods can be classified based on the types of analyzed variations:

- Dimensional (lengths and angles)
- Geometrical (flatness, roundness, angularity, etc.)

- Kinematic variations (small adjustments between mating parts in mechanical assemblies) [31]

Dimensional and geometrical variations are the result of variations in component parts due to manufacturing processes or raw materials used in production. Kinematic variations occur at assembly time, whenever small adjustments between mating parts are required to accommodate dimensional or form variations.

3.2.1 Tolerance analysis models

Figure 3 gives an overview on mathematical models used in tolerance analysis. Tolerance chain models, or dimensional tolerance chain models, fall into two categories:

1. Linear/linearized tolerance accumulation models. One of the most common models for the accumulation of component tolerances T_i into the predicted assembly tolerance T are, according to [73], worst-case models with

$$T = \sum_{i=1}^n T_i$$

Another commonly linearized model type, root sum square models (RSS, the original theoretical model of this method belongs to statistical category as discussed in the next section), has been used for tolerance estimation purpose as follows:

$$T = \sqrt{\sum_{i=1}^n T_i^2}$$

This approach is applied in [83, 84] to worst-case tolerance and root sum square tolerance analysis. A similar analysis method for more complex mechanical assemblies

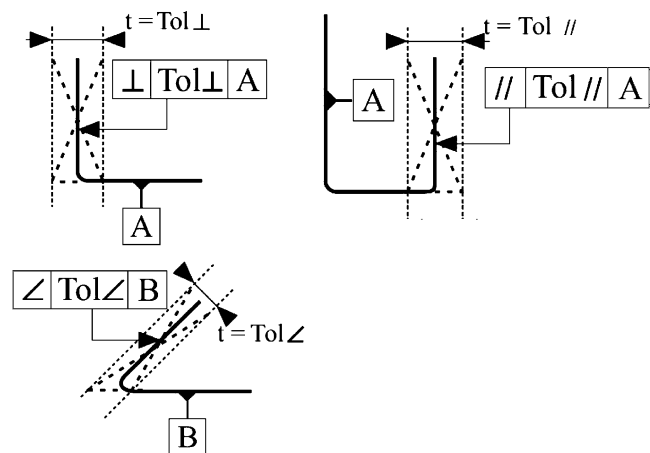
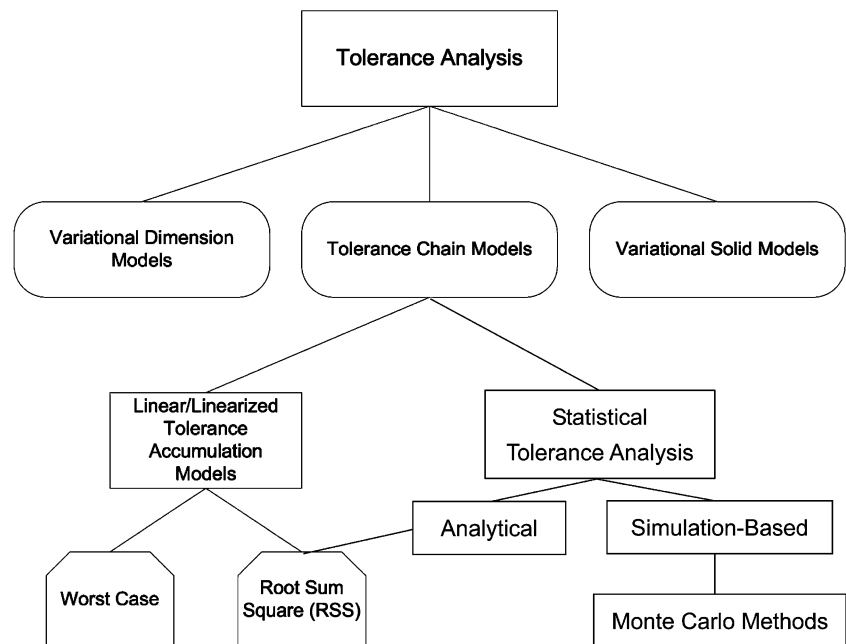

Fig. 2 Orientation tolerances (from ISO 1101:2002 and [53])

Fig. 3 Main tolerance analysis models

and kinematic linkages is based on the direct linearization method (DLM) [27, 28, 31, 77, 82, 248]. The role of tolerance and assembly analysis in robust assembly design is discussed in [66] and applied to nesting forces for exactly constrained mechanical assemblies in [162]. A comprehensive system based on dimensional tolerance chain model has been developed [29, 77] which includes dimensional, geometric, form, and kinematics sources; vector loops are defined by homogeneous transformation matrices, similar to robotics models.

2. Statistical analysis methods. In this category, two major approaches exist. The analytical analysis approach was developed from the tolerance chain technique, which aims to determine the probability distribution of system response functions [182]. RSS method belongs to this group. The DLM is applied to make the analysis model more convenient to use with small variations about the nominal dimensions [75, 82–84].

The second approach is simulation-based analysis. The most developed and commonly used method is Monte Carlo simulation which circumvents the difficulty in statistical tolerance analysis, which is to determine statistical moments of accumulated tolerances in a closed form. Therefore, Monte Carlo simulation methods are frequently used [32]. This method can be readily used for tolerance analysis, but is rarely for tolerance synthesis due to the difficulty to obtain derivatives of design functions [200]. The results of the direct linearization method with those obtained from the Monte Carlo simulation are compared in [75]. New metrics for assessing the accuracy of the Monte Carlo analysis method for assemblies are presented in [48].

Geometrical feature variations defined in ANSI Y14.5M-1994 are addressed statistically and propagated kinematically in a manner similar to the dimensional variations in assemblies [29].

Variational dimension models are a kind of special variational geometry in which only the dimension (size) can vary [184]. Recent research work focuses on tolerance sensitivity analysis in this area [63]. Variational solid models were developed to overcome the problems of variational dimensional models with non-polygonal/polyhedral models and certain types of geometrical tolerances [18]. They were shown to be appropriate for tolerance analysis of assemblies of toleranced parts [3, 127].

3.2.2 Three-dimensional tolerance analysis

With the advancement of 3D CAD and other engineering analysis technologies, the traditional dimensional tolerance chain models need to be enhanced to meet the requirements of explicit 3D geometrical tolerance specifications. A 3D tolerance propagation scheme has to address two related issues:

- Representation of tolerance zones and
- Spatial tolerance propagation mechanism

Categories of three-dimensional tolerance analysis methods are shown in Fig. 4.

Preliminary work motivating the development of the 3D tolerance propagation techniques is regarded as the spatial dimensional chain technique [163–165]. Other methods are mostly a variation of the spatial dimensional chain technique. For example in [163], the propagation of

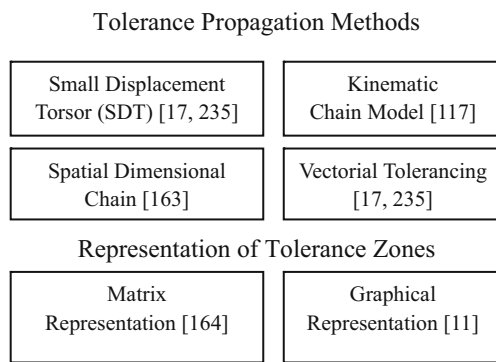

Fig. 4 Main three-dimensional tolerance analysis methods

position errors is taken into account in terms of a kinematic chain, where the individual error is represented as matrices with three-dimensional and three angular position errors. For pairs of functional elements in a kinematic chain model is associated with a set of six virtual joints, three for small translations, and three for small rotations [117].

Three-dimensional tolerance propagation models based on the concept of a small displacement torsor (SDT) are used to simulate three-dimensional fixturing and machining errors and their impacts on the geometry of the finished part. An SDT is a mathematical object that represents the displacement of a rigid body using three rotations and three translations. This approach models the influence of a process plan on functional tolerances as a chain of torsors. Assuming that the displacements are small enough, linearization is used to derive a torsor T as:

$$T = \begin{pmatrix} \alpha & u \\ \beta & v \\ \gamma & w \end{pmatrix} \quad (4)$$

where α , β , and γ are the small rotations of the element; u , v , and w are the small translations [17, 57].

The traditional tolerance chain models can be used for tolerance synthesis as shown in [30], but the related methods are relatively difficult to be uniformly generalized from case to case. The SDT-based and three-dimensional tolerance propagation overcomes such limitations. Based on the SDT method, a detailed model of mechanical parts, part-holders, and machining operations was developed [235] and extended to tolerance synthesis [236].

Vectorial tolerancing can be applied to geometrical tolerance analysis, see [231] for example. Form variations (ANSI Y14.5:1994) [29] and coordinate transformations can be used to represent tolerance zones [57]. Alternatively, a graphical representation of part features, process plans, and functional requirements defined with an ISO standard can be employed to analyze three-dimensional tolerance specifications and to generate manufacturing specifications compatible with ISO standards [11].

3.3 Tolerance synthesis

Tolerance synthesis, or tolerance allocation, is the reverse process of tolerance analysis. It provides a rational basis for assigning tolerances to working dimensions. Tolerance synthesis has enormous impact on cost and quality. It affects the fit and function of the product, which can cause poor performance and dissatisfied customers. With respect to manufacturing, tolerance requirements determine the selection of machines, tools, and fixtures; the operator skill level and set-up costs; inspection and gage precision; etc. In conclusion, tolerance synthesis affects almost every aspect of the product life cycle. Most tolerance synthesis approaches are based on the optimization of a cost-tolerance function. These approaches try to get optimal tolerance values when the tolerance stacks are assumed to be fixed. Nevertheless, the utilization of these models in industry is still limited. One major reason is that these models try to take advantage of the superficial knowledge of processes, which is usually obtained from machinist handbooks or company manuals. Process knowledge at this level cannot provide the designer with sufficiently precise tolerance values.

Commonly used tolerance synthesis methods include [27]:

- Allocation by proportional scaling: component tolerances are linearly scaled by a common proportionality factor.
- Allocation by constant precision factor: component tolerances are allocated by means of weight factors. In this way, weight factors are assigned to each component tolerance in the accumulation model and the system distributes a corresponding fraction of the tolerance pool to each component. Larger weight factors and corresponding bigger tolerances can be given to those dimensions that are the more costly or difficult to manufacture, which improves the cost and manufacturability of the design.
- Allocation by optimization techniques: the most popular optimization technique of component tolerance allocation is to minimize the cost of production of an assembly. It is accomplished by defining a cost-tolerance mathematical model for each component part in the assembly. An optimization algorithm assigns the tolerance for each component and searches systematically for the combination of tolerances that minimize the cost.

3.3.1 Tolerance synthesis models

Tolerance synthesis or tolerance allocation can be interpreted as minimizing a cost function $C(T)$ with respect to a

set of tolerances T . According to the nature of the target function $C(\cdot)$ (the cost is modeled to change linearly, reciprocally, or exponentially with the tolerance), existing tolerance synthesis models can be classified as shown in Fig. 5.

Cost-tolerance models are typical analytical cost estimation techniques [244]. The objective of these models is to estimate product cost considering design tolerances of a product as a function of the product cost. As an example, in the minimum cost optimization method, a set of tolerances is initially selected. Then, an optimization algorithm is used to find the minimal cost. However, due to the number of variables, the optimization can be rather involved, and a global minimum is often not attained [27, 30].

Some recent optimization methods are based on AI techniques, such as genetic algorithms, artificial neural networks, simulated annealing, neuro-fuzzy learning, and ant colony algorithm [166, 167].

Taguchi et al. presented quality engineering as an approach to handling tolerancing issues [211]. Quality engineering aims at an integrated production system with an overall quality control, in which every activity is controlled in order to produce the products with minimal deviations from target values. Details of various application methods of quality engineering to tolerance analysis and synthesis can be found in [46]; the application of parametric design and quality loss functions is discussed in [39, 70, 71].

Statistical tolerancing synthesis (and process capability index applications) drew attention in recent years. It assumes that the final tolerance specifications and the distributions of the process dimensions are known [230]. This idea was further developed:

- The distribution function zone approach was extended to an optimized cost-tolerance model, which

solves the statistical tolerance synthesis problems. The model is illustrated with an assembly example in [259].

- Process capability index applications in tolerance synthesis are another important research area [187].
- An optimization model, named reliability index model, with consideration of the required functional reliability, the minimum machining cost, and quality loss was established [104].

In summary, tolerance synthesis is mainly used for assembly tolerances. However, tolerance synthesis for parts, especially sheet metal parts, has its own, only partly addressed, characteristics.

3.4 Tolerance transfer

Tolerance transfer, as tolerance analysis and synthesis in process planning, is a method to convert design tolerances into a manufacturing plan.

3.4.1 Conventional tolerance transfer method

Tolerance charting is the most popular conventional tolerance transfer technique. A tolerance chart is a graphical tool for process planners to determine the manufacturing dimensions and tolerances of each machining operation, based on the design dimensions and tolerances.

The fundamental idea of tolerance charting is discussed in [21, 22]. The two main fundamental tolerance charting techniques, Wade’s and Bourde’s model, are compared in detail in [126]. The author concludes that Bourde’s model appears more appropriate for the treatment of resultant dimensions obtained under a single setup.

Fig. 5 Main tolerance synthesis methods

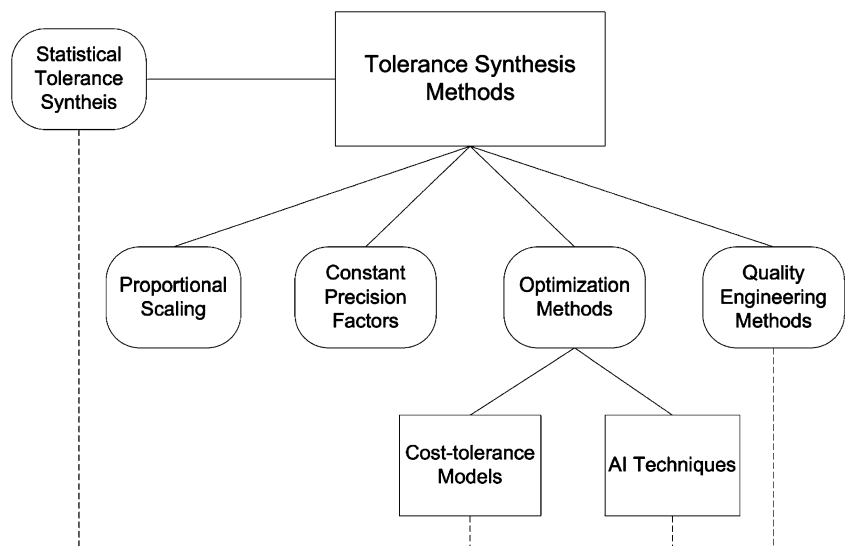

An overview of important tolerance charting-based approaches is given in [98]. Since then, the three referenced approaches were further developed:

- Angular tolerance charting [106, 107, 255, 256]
- Digraphic tolerance charts [1, 157]
- Rooted tree model and datum-hierarchy tree method [20, 221, 222]

Although tolerance charting is applied widely in tolerance transfer, it has a major shortcoming: it cannot deal with complex spatial tolerance transfer issues or geometrical tolerances.

3.4.2 Three-dimensional tolerance transfer

Most tolerance charting techniques can handle only the size-dimensional tolerances or a limited set of geometric tolerances. Thus, it is necessary to develop new tolerance propagation techniques in process planning for 3D tolerance transfer, especially for geometric tolerances. Existing approaches to three-dimensional tolerance analysis that are suitable for tolerance transfer are listed in Table 3.

3.5 Monte Carlo simulation

The Monte-Carlo, or random sampling, method numerically determines approximate solutions in mathematical physics and engineering [177]. This stochastic technique was utilized for centuries, but only from 1940s has it gained the status of a method capable to address complex applications.

The Monte Carlo method has been used extensively for statistical tolerancing. Derivation of the statistical moments of a function of random variables is usually impossible in closed form, especially when the functional form is complicated or piecewise-defined. The Monte Carlo method has the advantage of simplicity and flexibility. However, this method can be computationally expensive. With the improvement of computational capacity of computers, the Monte Carlo method is adopted by many software packages, for example, variation simulation analysis, and then applied in some commercial software including CATIA, Pro/Engineer, and UG [98, 178].

The Monte Carlo method can be easily used for tolerance analysis [76, 98, 186, 200], but it was rarely used in tolerance synthesis, as it is difficult to obtain derivatives

or gradients with it. This changed, though, in recent years [59, 102, 118, 121, 122, 134, 203].

4 Applying feature-based tolerance analysis in CAPP

4.1 Current tendency

The Society of Manufacturing Engineers defines process planning as the systematic determination of methods by which a product is to be manufactured, economically and competitively.

In other words, process planning is the transposition of engineering design information into process steps and instructions to efficiently and effectively manufacture products. Process planning activities include the following [241]:

- Interpretation of product design data
- Determination of production tolerances
- Determination of setup requirements
- Selection of tool sets
- Selection of machine tools
- Sequencing of operations
- Tool path planning
- Determination of machining conditions
- Generation of process route sheets
- Selection of machining methods and processes
- Design of jigs and fixtures
- Calculation of process times
- NC program generation
- Capacity planning

Although CAPP uses almost the same steps taken in manual process planning, it requires less time compared with manual process planning. Due to the rapid diminishing number of experienced process planners in industry, compressed product life cycles, and the broad use of CAD/CAM, the research on CAPP has gained more attention than ever before. Approaches used in CAPP can be categorized as two types [152]:

- *Variant process planning* follows the principle that similar parts require similar plans. This technology is often used with group technology for coding and classification.
- *Generative process planning* utilizes decision logic, formulae, manufacturing rules, and geometry-based

Table 3 Three-dimensional tolerance transfer methods

Small displacement tector (SDT) and proportioned assembly clearance volume (PACV)	[125, 215, 216, 235]
Technologically and topologically related surfaces model (TTRS)	[56, 58]
Product data translator (PDT) approach	[263]

data to develop a new plan for each part based on input about the part's features and attributes.

Beside the above classification, research can be categorized on the basis of their geometrical modeling (Fig. 6). Most research in this area is focused on optimization of process plans, although some other issues, such as knowledge and data management in CAPP, are important topics [55]. Optimization techniques used in CAPP can be categorized as:

- Knowledge-based reasoning [43, 250].
- Graph theoretic approaches [19, 44, 105, 136, 223].
- Heuristic algorithms [131, 132, 169].
- Artificial intelligence, such as evolutionary or genetic algorithms, artificial neural network, fuzzy logic, expert systems, and so on [6, 15, 44, 81, 119, 120, 130, 172].

4.1.1 The concept of features

The use of features originates in the reasoning processes to associate domain knowledge with object representations by natural means. Numerous feature definitions are used in CAD, computer-aided engineering (CAE), Computer-aided process planning (CAPP), and CAM. At first, machining features were used to integrate CAPP and CAM packages on a geometrical level. More recently, the feature concept was expanded to relations between geometrical and non-geometrical entities. Historical definitions of features are reviewed in Table 4.

Regardless of how features are defined, features can be considered as the smallest elements which possess explicit engineering meaning. Therefore, features are suitable as a link between life cycle stages. According to their applications in different stages, features can be classified for the following engineering stages (modified from [33]): conceptual design, embodiment design, detailed design, assembly design, CAE, manufacturing, process planning, and inspection.

It can be envisaged that a new stream of feature technology is to be developed for geometric and dimensional tolerance (GDT) applications. Such features are to be identified and related to computer-aided tolerancing functions. With them, systematic design tolerance specifications

can be modeled and captured in the detailed design stage. These features may involve a hierarchical relation tree to associate the ideal functionality of a product to each individual assembly feature tolerance. Such an assembly tolerance feature can be further broken down into a set of associated part GDT tolerance features that are required when specifying individual part tolerances. At both stages of tolerance specification, tolerance propagation and synthesis are to be involved and always part of the design task for manufacturing aspect. The application of geometric and dimensional tolerance when a process plan is developed and the final inspection carried out requires the implementation and check of tolerance features with manufacturing tooling, processes, and measures.

Sheet metal feature definitions are as diverse as the general feature definitions discussed above. In order to support design and process planning for sheet metal forming, sheet metal features highlight formability. Thus, the following attributes define the sheet metal forming features of the part in design and process planning stage [modified from 214]: feature identifier, feature form, material, dimensions associated with the feature, geometrical tolerance associated, primary working direction or die closure direction, positioning datum, and sheet metal forming method.

4.1.2 Associative features

Associative features are a recently defined group of user-defined, object-oriented, self-contained, and flexible semantic features [16]. They are proposed as classes to represent relations between different forms of non-geometrical and geometrical entities depending on specific applications [143–147]. Based on object-oriented technology, those features that are difficult to be defined in a traditional feature concept can be modeled parametrically and generically. Associative features are consistent to model the evolution of features in different stages of product life cycle.

Figure 7 shows a sheet metal part that can be fully defined with some typical associative forming features. First, basic geometric features are defined as those primary features or elemental plates which represent the overall shape of a sheet metal part as the base for more detailed shape definitions. In Fig. 7, the primary feature is the S-plate. The primary features include plates, walls, L-brackets, U-channels, curves, and boxes. Then, based on the above primary features, subsidiary features can be defined to represent those manufacturing-related feature elements which represent localized characters of a sheet metal part. Subsidiary features are modifications of the basic features. Typical subsidiary features are bends, pierced holes, extruded holes, embosses, lancing forms,

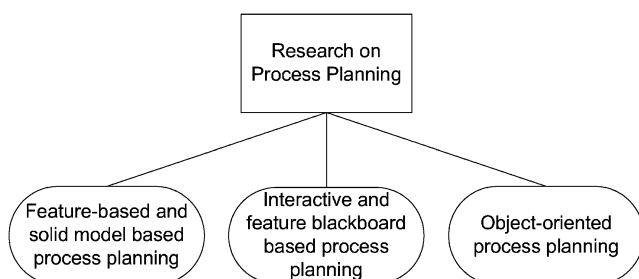

Fig. 6 Research on process planning

Table 4 Definition of features

Definition of a feature	Source
A region of interest in a part model	[246]
Any geometric form or entity that is used in reasoning in one or more design or manufacturing activities	[47]
Generic shapes associated to certain properties or attributes and knowledge useful in reasoning about the product	[183, 185]
A partial form or a product characteristic that is considered as a unit and that has a semantic meaning in design, process planning, manufacture, cost estimation, or other engineering discipline	[245]
Regions of an object that are meaningful for a specific activity or application	[229]
A representation of geometrical shape with a set of engineering attributes	[25]
The representation of shape aspects of a physical product that are mappable to a generic shape and that have functional significance	[184]
A set of form elements with a functional meaning in a given application context that allows an association between shapes and functionality	[153]
A representation of shape aspects of a product that are mappable to a generic shape and functionally significant for some product life cycle phase	[16]

hems, beads, slots, bosses, ribs, and set-outs. In Fig. 7, the four bends and the hole are subsidiary features.

In addition, sheet metal forming resources, such as machining tools and fixtures, can be explicitly defined in feature class as attributes or constraints. The associations can be created by reasoning processes such as sequencing, tool selection, gage selection, and fixture selection. A potential feature-based sheet metal forming planning system can be developed based on the relevant associative feature theory and applications [33–36] because in the above-listed references, associative concept design features, detailed design features, and process planning features have been defined using a unified feature model. A prototype system was developed to demonstrate the capability and feasibility of the proposed product modeling scheme.

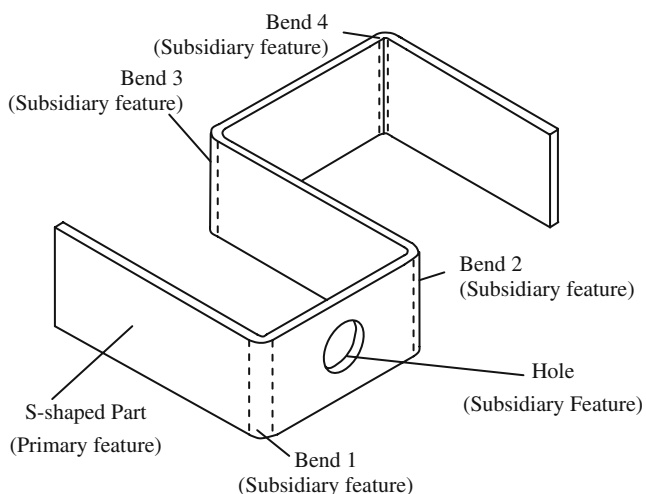
**Fig. 7** Examples of sheet metal part features

4.1.3 Feature-based process planning

Feature-based process planning plays a crucial role in an integration effort of product life cycle. In feature-based process planning, machining features are recognized CAD model, and machining processes and their sequences are determined based on the features and other machining information.

With a feature-based hierarchical description of the part design, process planning decisions are made based on individual features or groups of features. A feature-based approach allows one to automate or semi-automate the processes from design to manufacturing. A simple feature-based flexible process planning system is laid out in Fig. 8. A summary of recent research in this field is given in Table 5.

Feature-based process planning was a hot research field in recent years. Although many researchers focus on developing CAPP systems [8, 9, 25, 37] or finding optimal process planning procedures, more and more attention is paid to the details of applying feature techniques on process planning. For example, besides feature modeling and recognition [5, 10], *design by features* approach is utilized in feature conversion, composition, and de-composition [7, 12, 24, 47]. Association and integration of CAD/CAE/CAM and CAPP [23, 25] are equally important topics, and more attention is focused on optimization methods by AI [13, 61, 108].

4.2 Process planning in sheet metal forming

4.2.1 Overview

In the 1990s, process planning for small batch part manufacturing of sheet metal parts became a major research area. Some researchers focus on computer-aided process

Fig. 8 Example of a simple feature-based process planning system

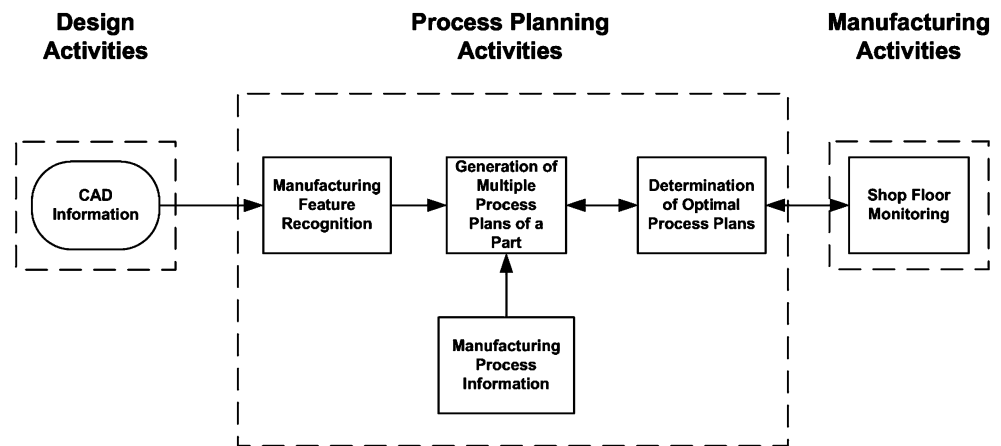

planning for sheet metal forming [136, 170, 227]. The sheet metal manufacturing process comprises many complex operations, which make it difficult to construct a comprehensive CAPP system for all sheet metal parts. Being the most common operation of sheet metal forming, bending is one of the most researched topics in this field [72, 219]. Other operations such as drawing or combined operations begin to gain more attention. Table 6 shows a survey of papers on CAPP of sheet metal forming. Only certain typical operations were selected for review, as too many sheet metal forming methods exist to be listed comprehensively.

4.2.2 Feature-based process planning in sheet metal forming

An early topic in this field is feature representation and classification. In [49–54], a CAPP system is presented which relies on a feature type referred to as *connections*. A connection is a design feature, typically a bend or a welded seam. A further division, the bend features in simple bends and those with hemmed or curled edges, is discussed in [225]. Basic sheet metal features are classified in [14] into walls, bends, form features, cuts, punches, notches, and so on.

An integrated system presented in [239] for the design and production of sheet metal parts identifies several bend features: bend graph, internal tab, essential and optional collinear bend, outside/inside bend, taller flange, shorter/longer bend, channel, corner, hemming bend, large-radius bend, part overhang, louver, and dimple.

A fully automated experimental feature recognition system for sheet metal forming process planning extracts the sheet metal feature information from 2D orthographic drawings to generate process plan without any user interaction [197].

Other research is focused on the development of feature-based process planning systems:

- In the integrated modeling and process planning system developed by [40, 41, 45, 128] for planning bending operations of progressive dies, the geometrical bend mapping function for feature elements within individual bends and the transformation matrix for connected sub-bends are formulated.
- A prototype STEP-compliant process planning system for sheet metal product development integrates software modules for nesting optimization, path optimization,

Table 5 Summary: features in process planning

Topic	Source
Feature modeling and classification	[8, 173, 226]
Roles of manufacturing features in process planning	[228]
Feature recognition/extraction technique	[5, 10, 24, 65, 94, 96, 109, 113, 115, 139, 154, 161, 174, 209, 252]
Feature-based CAPP system	[9, 37, 38, 62, 64, 92, 111, 137, 140, 161, 242, 253, 258]
Integration of CAD/CAE/CAM and CAPP	[33, 100, 224, 251]
Feature-based analysis of the manufacturability of machined parts	[90]
Feature composition and decomposition	[123, 124, 133, 210]
Feature-based process planning for environmentally conscious machining	[205, 206]
Feature-based inspection process planning	[13, 249, 261]
Optimization by AI and KBE techniques	[61, 108, 141, 198, 199]

Table 6 Review on CAPP for sheet metal forming

	All operations	Bending	Punching	Drawing	Blanking	CAPP system	Operation and tool selection	Sequencing
[202]	√					√		√
[97]		√						√
[50]		√				√		√
[207]	√					√		
[54]		√				△	√	
[168]		√						√
[89]		√				√	√	√
[40]		√			√	√		
[87]		√					√	
[191]		√						√
[51]		√				√		△
[142, 208]	√					√		
[219]		√					√	√
[91]	√						√	
[112]		√	√			√	△	
[160]				√		√		
[103]			√				√	√
[67]		√					√	
[201]	√					√		
[240]			√			△	√	√
[45]	√			△			√	√
[234]		√	√				△	△
[44]			√			√	√	√
[49]	√					√		
[204]	√					√	△	△
[192]		√						√
[74]		√					√	
[158]		√					△	√
[52]		√					√	
[135]		√					√	√
[68]		√						√
[88]		√					√	√
[41]				√	√	√		
[78]	√					√		
[7]	√						√	
[12]	√						√	√
[110]				√		√		△
[151]		√					△	△
[220]		√						√
[176]		√						√
[156]		√					√	
[237]	√					√	√	△
[23]		√					△	√
[171]			√		√	√		
[81]			√			√	√	√

Tick symbol discussed in detail, triangle touched on

tion and planning, simulation, and machining parameters set-up and CNC machining [254].

- Another CAPP system based on feature technique addresses stamping processes for automobile panels [262].

Feature-based sheet metal part stampability evaluation and stamping process planning approaches have been studied in a two-part paper. The first part identifies the aims and criteria of a stampability evaluation and formalizes the stampability evaluation knowledge [212]. The second part presents a feature mapping system which connects the stamping design feature space and the stamping process feature space [213].

Opposed to traditional machining process planning, feature-based process planning for sheet metal forming is little represented in literature. Feature representation, classification, recognition, and development of feature-based process planning systems are current research topics; other characteristics of sheet metal forming processes are unaddressed.

5 Tolerance transfer in sheet metal part forming

Tolerance transfer in process planning of sheet metal part forming attracted only little attention in the past as shown in Table 7 according to available literature. Furthermore, all the references listed focus on bending operations and raise or leave the following issues unaddressed:

- Computer-aided tolerancing does not address processes including several operations of distinct nature, such as bending, punching, blanking, and deep-drawing.
- Machining errors and their causes and inter-dependencies are not characterized comprehensively as the sources of final error accumulation, although some of the errors are discussed in papers above.
- Only size-dimensional tolerances (using conventional worst-case models) are discussed in detail.

- Statistical tolerancing approaches reflect actual part tolerances better than worst-case tolerancing. However, they are utilized only for sheet metal assembly issues [200] or size dimensions [79, 80, 93].
- Tolerance synthesis/allocation for sheet metal part forming are seldom studied. Currently, research works are focused on sheet metal assembly [150, 188].

6 Summary

Even though process tolerances of individual sheet metal forming operations are well understood and the industry has adopted geometric tolerances and dimensions via some standards, the combinational theory and applications of tolerance stacks and the allocation of tolerances to individual operations are not mature. This discrepancy is mostly due to insufficiencies of tolerance transfer methods—certain differences with assemblies and material removal methods make the problem a unique challenge. Only a small number of publications address geometric tolerances and, as compared with metal removal processes or assemblies, they cover a limited scope and depth. We observed the following points:

- Insufficient coverage of operations. Although there have been numerous publications addressing CAPP for sheet metal, including systems, operation, tool selection, and sequencing, more than half of the 46 publications examined by the authors focus on bending operations only.
- Limited integration to other computer solutions. Feature-based process planning considering sheet metal forming tolerancing, i.e., geometric tolerance feature associations in the integrations of CAD, CAE, CAM, and CAPP are only partially addressed.
- More research work is required for tolerance transfer of geometric dimensions. Only nine publications were discovered by the authors.
- Geometric tolerance synthesis should be studied; no publication has been found.

Table 7 Tolerance transfer in sheet metal part forming

Resource	Size dimensional tolerance	GD&T	Tolerance analysis	Tolerance synthesis	Worse case	Statistical tolerancing	Analytic	Graphical
[52–54]	√	△	√		√		√	△
[191]	√		√		√		√	△
[79, 80, 93]	√		√			√	√	
[95]	√		√		√			√
[12]	√		√		√		√	

Tick symbol discussed in detail, triangle touched on

References

1. Ahluwalia RS (2002) Tolerance analysis in process planning. *Int J Ind Eng-Theory Appl Pract* 9(4):334–342
2. Ahmed M, Sekhon GS, Singh D (2005) Finite element simulation of sheet metal forming processes. *Def Sci J* 55(4):389–401
3. Akella S, Mason MT (2000) Orienting toleranced polygonal parts. *Int J Rob Res* 19:1147–1170
4. Alberti N, Fratini L (2004) Innovative sheet metal forming processes: numerical simulations and experimental tests. *J Mater Process Technol* 150(1–2):2–9
5. Aldakhilallah KA, Ramesh R (1997) Recognition of minimal feature covers of prismatic objects: a prelude to automated process planning. *Int J Prod Res* 35(3):635–650
6. Allen RD, Harding JA, Newman ST (2005) The application of STEP-NC using agent-based process planning. *Int J Prod Res* 43(4):655–670
7. Alva U, Gupta SK (2001) Automated design of sheet metal punches for bending multiple parts in a single setup. *Robot Comput Integr Manuf* 17(1–2):33–47
8. Amaitik SM, Kilic SE (2005) STEP-based feature modeller for computer-aided process planning. *Int J Prod Res* 43(15):3087–3101
9. Amaitik SM, Kilic SE (2006) An intelligent process planning system for prismatic parts using STEP features. *Int J Adv Manuf Technol* 31(9–10):978–993
10. Ando K, Muljadi H, Ogawa M (2005) Manufacturing feature recognition method for the generation of multiple process plans. *JSME Int J Series C-Mech Syst Mach Elem Manuf* 48(2):269–277
11. Anselmetti B, Louati H (2005) Generation of manufacturing tolerancing with ISO standards. *Int J Mach Tools Manuf* 45(10):1124–1131
12. Aomura S, Koguchi A (2002) Optimized bending sequences of sheet metal bending by robot. *Robot Comput Integr Manuf* 18(1):29–39
13. Beg J, Shunmugam MS (2003) Application of fuzzy logic in the selection of part orientation and probe orientation sequencing for prismatic parts. *Int J Prod Res* 41(12):2799–2815
14. Belarbia R, Belbehoulou R, Marty C (1996) Hybrid feature recognition for sheet metal parts. In *Proceedings of the 4th International Conference on Sheet Metal*. Enschede, pp 83–91
15. Berenji HR, Khoshnevis B (1986) Artificial intelligence in automated process planning. *Comput Mech Eng* 5(2):47–55
16. Bidarra R, Bronsvort WF (2000) Semantic feature modeling. *Comput Aided Des* 32(3):201–225
17. Bourdet P, Mathieu L, Lartigue C, Ballu A (1996) The concept of the small displacement torsor in metrology. *Adv Math Tools Metrol* 40:110–122
18. Boyer M, Stewart NF (1991) Modelling spaces for toleranced objects. *Int J Rob Res* 10:570–582
19. Britton G, Thimm G, Beng TS et al (2002) A graph representation scheme for process planning of machined parts. *Int J Adv Manuf Technol* 20(6):429–438
20. Britton GA (2002) Datum-hierarchy tree method for tolerance analysis of plating and heat treatment operations. *Int J Adv Manuf Technol* 20(6):442–447
21. Britton GA, Fok SC, Whybrew K (2001) A review of the evolution of a graph theoretic approach to computer aided process planning. *Int J Intell Autom Soft Comput* 7(1):35–42
22. Britton GA, Whybrew K (1997) Chapter 17—CATCH: computer aided tolerance charting. In: *Advanced tolerancing techniques*. Wiley, New York, pp 461–489
23. Cattrysse D, Beullens P, Collin P et al (2006) Automatic production planning of press brakes for sheet metal bending. *Int J Prod Res* 44(20):4311–4327
24. Chan AKW, Case K (1994) Process planning by recognizing and learning machining features. *Int J Comput Integr Manuf* 7(2):77–99
25. Chan KC, Nhieu J (1993) A framework for feature-based applications. *Comput Ind Eng* 24(2):151–164
26. Chan WM, Chew HI, Lee HP et al (2004) Finite element analysis of spring-back of v-bending sheet metal forming processes. *J Mater Process Technol* 148(1):15–24
27. Chase KW (1999) Chapter 13—multi-dimensional tolerance analysis, chapter 14—minimum-cost tolerance allocation. *Dimensioning and tolerancing handbook*. McGraw-Hill, New York, In
28. Chase KW, Gao J, Magleby SP (1995) General 2-D tolerance analysis of mechanical assemblies with small kinematic adjustments. *J Des Manuf* 5(4):263–274
29. Chase KW, Gao JS, Magleby SP et al (1996) Including geometric feature variations in tolerance analysis of mechanical assemblies. *IIE Transactions* 28(10):795–807
30. Chase KW, Greenwood WH, Loosli BG et al (1989) Least cost tolerance allocation for mechanical assemblies with automated process selection. *Manuf Rev, ASME* 2(4):49–59
31. Chase KW, Magleby SP, Glancy CG (1997) A comprehensive system for computer-aided tolerance analysis of 2-D and 3-D mechanical assemblies. In: *Proceedings of the 5th CIRP Seminar on Computer-Aided Tolerancing*. Toronto, Ontario
32. Chase KW, Parkinson AR (1991) A survey of research in the application of tolerance analysis to the design of mechanical assemblies. *Res Eng Des-Theory Appl Concurr Eng* 3:23–37
33. Chen G (2007) Unified feature model for the integration of CAD and CAx. PhD Thesis, Nanyang Technological University, Singapore
34. Chen G, Ma YS, Thimm G et al (2004) Unified feature modeling scheme for the integration of CAD and CAx. *Compr-Aided Des Appl* 1(1–4):595–601
35. Chen G, Ma YS, Thimm G et al (2005) Knowledge-based reasoning in a unified feature modeling scheme. *Compr-Aided Des Appl* 2(1–4):173–182
36. Chen G, Ma YS, Thimm G et al (2006) Associations in a unified feature modeling scheme. *ASME Trans, J Comput Inf Sci Eng* 6(2):114–126
37. Chen YF, Huang ZD, Chen LP et al (2006) Parametric process planning based on feature parameters of parts. *Int J Adv Manuf Technol* 28(7–8):727–736
38. Cherngm JG, Shao XY, Chen YB et al (1998) Feature-based part modeling and process planning for rapid response manufacturing. *Comput Ind Eng* 34(2):515–530
39. Choi HGR, Park MH, Salisbury E (2000) Optimal tolerance allocation with loss functions. *J Manuf Sci Eng: Trans ASME* 122(3):529–535
40. Choi JC, Kim BM, Kim C (1999) An automated progressive process planning and die design and working system for blanking or piercing and bending of a sheet metal product. *Int J Adv Manuf Technol* 15(7):485–497
41. Choi JC, Kim C, Choi Y et al (2000) An integrated design and CAPP system for deep drawing or blanking products. *Int J Adv Manuf Technol* 16(11):803–813
42. Choi SH, Chin KG (2006) Prediction of spring-back behavior in high strength low carbon steel sheets. *J Mater Process Technol* 171(3):385–392
43. Chu CCP, Gadh R (1996) Feature-based approach for set-up minimization of process design from product design. *Comput-Aided Des* 28:321–332

44. Chu CY, Tor SB, Britton GA (2007) Graph theoretic algorithm for automatic operation sequencing for progressive die design. *Int J Prod Res* 46(11):2965–2988
45. Ciurana J, Ferrer I, Gao JX (2006) Activity model and computer aided system for defining sheet metal process planning. *J Mater Process Technol* 173(2):213–222
46. Creveling CM (1997) *Tolerance design: a handbook for developing optimal specifications*. Addison-Wesley, Reading, MA
47. Cunningham JJ, Dixon JR (1988) Designing with features: the origin of features. In: *Proceedings of 1988 ASME International Computers in Engineering Conference*. San Francisco, pp 237–243
48. Cvetko R, Chase KW, Magleby SP (1998) New metrics for evaluating Monte Carlo tolerance analysis of assemblies. In: *Proceedings of the ASME International mechanical engineering conference and exposition*. Anaheim, CA
49. De Vin LJ, De Vries J, Streppel AH et al (1992) PART-S, a CAPP system for small batch manufacturing of sheet metal components. In: *Proceedings of 24th CIRP Seminar on Manufacturing Systems*. Copenhagen, Denmark
50. De Vin LJ, De Vries J, Streppel AH et al (1994) The generation of bending sequences in a CAPP system for sheet metal components. *J Mater Process Technol* 41(3):331–339
51. De Vin LJ, De Vries J, Streppel T (2000) Process planning for small batch manufacturing of sheet metal parts. *Int J Prod Res* 38(17):4273–4283
52. De Vin LJ, Streppel AH (1998) Tolerance reasoning and set-up planning for brakeforming. *Int J Adv Manuf Technol* 14(5):336–342
53. De Vin LJ, Streppel AH, Kals HJJ (1994) Tolerancing and sheet metal bending in small batch part manufacturing. *Annals of the CIRP* 43(1):421–424
54. De Vin LJ, Streppel AH, Kals HJJ (1996) The accuracy aspect in set-up determination for sheet bending. *Int J Adv Manuf Technol* 11(3):179–185
55. Denkena B, Shpitalni M, Kowalski P et al (2007) Knowledge management in process planning. *CIRP Annals-Manuf Technol* 56(1):175–180
56. Desrochers A (2003) A CAD/CAM representation model applied to tolerance transfer methods. *J Mech Des* 125(1):14–22
57. Desrochers A, Riviere A (1997) A matrix approach to the representation of tolerance zones and clearances. *Int J Adv Manuf Technol* 13:630–636
58. Desrochers A, Verheul S (1999) A three dimensional tolerance transfer methodology. In: *Global consistency of tolerances*. Proceedings of the 6th CIRP International Seminar on Computer-Aided Tolerancing, University of Twente, Enschede, The Netherlands, pp 83–92
59. Di Stefano P (2006) Tolerances analysis and cost evaluation for product life cycle. *Int J Prod Res* 44(10):1943–1961
60. Diegel O (2002) The fine-art of sheet metal bending. Technical report, The Institute of Technology and Engineering, Massey University. Available at: http://www.massey.ac.nz/_odiegel/bendworks/bending.pdf
61. Ding L, Yue Y, Ahmet K et al (2005) Global optimization of a feature-based process sequence using GA and ANN techniques. *Int J Prod Res* 43(15):3247–3272
62. Dong J, Jo HH, Parsaei HR (1992) A feature-based dynamic process planning and scheduling. *Comput Ind Eng* 23(1–4):141–144
63. Dong J, Shi Y (1997) Tolerance sensitivity analysis in a variational design environment. *Int J Veh Des* 18(5):474–486
64. Dong JJ, Parsaei HR (1994) Design and implementation of a feature-based automated process planning (FBAPP) system. *Comput Ind Eng* 27(1–4):1–4
65. Dong JJ, Parsaei HR, Gornet T (1993) Manufacturing features extraction and recognition in automated process planning. *Comput Ind Eng* 25(1–4):325–328
66. Downey K, Parkinson AR, Chase KW (2003) An introduction to smart assemblies for robust design. *Res Eng Des-Theory Appl Concurr Eng* 14(4):236–246
67. Duou JR, Nguyen THM, Kruth JP et al (2005) Automated tool selection for computer-aided process planning in sheet metal bending. *CIRP Annals-Manuf Technol* 54(1):451–454
68. Duou JR, Van Oudheusden D, Kruth JP et al (1999) Methods for the sequencing of sheet metal bending operations. *Int J Prod Res* 37(14):3185–3202
69. Duou JR, Vancza J, Aerens R (2005) Computer aided process planning for sheet metal bending: a state of the art. *Comput Ind* 56(7):747–771
70. Feng CX, Kusiak A (2000) Robust tolerance synthesis with the design of experiments approach. *J Manuf Sci Eng: Trans ASME* 122(3):520–528
71. Feng CX, Wang J, Wang JS (2001) An optimization model for concurrent selection of tolerances and suppliers. *Comput Ind Eng* 40:15–33
72. Fleischer J (1992) Computer-aided process planning for the flexible automated sheet metal bending. *IFIP Trans B-Appl Technol* 1:417–428
73. Fortini ET (1967) *Dimensioning for interchangeable manufacture*. Industrial Press, New York
74. Franke V (1995) Automation of tool planning for bent components. In: *Proceedings of the 3rd International Conference on Sheet Metal, SHEMET 1995*. Birmingham, UK, pp 35–44
75. Gao J, Chase KW, Magleby SP (1995) Comparison of assembly tolerance analysis by the direct linearization and modified Monte Carlo simulation methods. In: *Proceedings of the ASME Design Engineering Technical Conferences*. Boston, MA, pp 353–360
76. Gao J, Chase KW, Magleby SP (1996) A new Monte Carlo simulation method for tolerance analysis of kinematically constrained assemblies. Technical report, Mechanical Engineering Department, Brigham Young University. Available at: <http://adcats.et.byu.edu/Publication/doc4/paper4.html>, accessed on April 20, 2010.
77. Gao J, Chase KW, Magleby SP (1998) Generalized 3-D tolerance analysis of mechanical assemblies with small kinematic adjustments. *IIE Trans* 30:367–377
78. Gao JX, Tang YS, Sharma R (2000) A feature model editor and process planning system for sheet metal products. *J Mater Process Technol* 107(1–3):88–95
79. Geiger M, Hagenah H (1999) Evaluation of manufacturing plans in sheet metal bending with respect to the achievable workpiece accuracy. *Prod Eng* VI(2):139–142
80. Geiger M, Hagenah H, Menzel T (2000) Simulation based optimisation of the accuracy of sheet metal bending parts caused by the manufacturing plan. In: *Proceedings of the 2nd CIRP International Seminar on Intelligent Computation in Manufacturing Engineering (ICME 2000)*. Capri, Italy, pp 283–290
81. Giannakakis T, Vosniakos GC (2008) Sheet metal cutting and piercing operations planning and tools configuration by an expert system. *Int J Adv Manuf Technol* 36(7–8):658–670
82. Glancy CG, Chase KW (1999) A second-order method for assembly tolerance analysis. In: *Proceedings of the ASME Design Engineering Technical Conference*. Las Vegas, NV, pp 12–15
83. Greenwood WH, Chase KW (1988) Worst case tolerance analysis with nonlinear problems. *J Eng Ind: Trans ASME* 110:232–235
84. Greenwood WH, Chase KW (1990) Root sum squares tolerance analysis with nonlinear problems. *J Eng Ind: Trans ASME* 112:382–384

85. Groover MP (2001) Chapter 20: sheet metalworking, fundamentals of modern manufacturing. In: Materials, processes, and systems, 2nd edn. Wiley, New York
86. Guo YQ, Batoz JL, Naceur H et al (2000) Recent developments on the analysis and optimum design of sheet metal forming parts using a simplified inverse approach. *Comput Struct* 78(1–3):133–148
87. Gupta SK (1999) Sheet metal bending operation planning: using virtual node generation to improve search efficiency. *J Manuf Syst* 18(2):127–139
88. Gupta SK, Bourne DA (1999) Sheet metal bending: generating shared setups. *J Manuf Sci Eng Trans ASME* 121(4):689–694
89. Gupta SK, Bourne DA, Kim KH et al (1998) Automated process planning for sheet metal bending operations. *J Manuf Syst* 17(5):338–360
90. Gupta SK, Nau DS (1995) Systematic approach to analysing the manufacturability of machined parts. *Comp Aided Des* 27(5):323–342
91. Gupta SK, Rajagopal D (2002) Sheet metal bending: forming part families for generating shared press-brake setups. *J Manuf Syst* 21(5):329–349
92. Gupta SK, Rao PN, Tewari NK (1992) Development of a CAPP system for prismatic parts using feature based design concepts. *Int J Adv Manuf Technol* 7:306–313
93. Hagenah H (2003) Simulation based evaluation of the accuracy for sheet metal bending caused by the bending stage plan. In: Proceedings of the 36th CIRP Seminar on Manufacturing Systems, Progress in Virtual Manufacturing Systems. Saarbruecken, Germany, pp 513–519
94. Han JW, Han IH, Lee E et al (2001) Manufacturing feature recognition toward integration with process planning. *IEEE Trans Syst Man Cybern B Cybern* 31(3):373–380
95. Han TJ (2001) Tolerance analysis and charting of the sheet metal punch and bending forming process. M.Sc. Thesis, Nanyang Technology University, Singapore
96. Herbert PJ, Hinde CJ, Bray AD et al (1990) Feature recognition within a truth maintained process planning system. *Int J Comput Integr Manuf* 3(2):121–132
97. Homann M, Geissler U, Geiger M (1992) Computer aided generation of bending sequences for die-bending machines. *J Mater Process Technol* 30(1):1–12
98. Hong YS, Chang TC (2002) A comprehensive review of tolerancing research. *Int J Prod Res* 40(11):2425–2459
99. Hosford WF, Duncan JL (1999) Sheet metal forming: a review. *JOM-J Miner, Met Mater Soc* 51(11):39–44
100. Hou M, Faddis TN (2005) Automatic tool path generation of a feature-based CAD/CAPP/CAM integrated system. *Int J Comput Integr Manuf* 19(4):350–358
101. Hsu CW, Ulsoy AG, Demeri MY (2002) Development of process control in sheet metal forming. *J Mater Process Technol* 127(3):361–368
102. Huang SH, Liu Q, Musa R (2004) Tolerance-based process plan evaluation using Monte Carlo simulation. *Int J Prod Res* 42(23):4871–4891
103. Huang SH, Automatic NXu (2003) Set-up planning for metal cutting: an integrated methodology. *Int J Prod Res* 41(18):4339–4356
104. Huang YM, Shiau CS (2006) Optimal tolerance allocation for a sliding vane compressor. *J Mech Des* 128(1):98–107
105. Irani SA, Koo HY, Raman S (1995) Feature-based operation sequence generation in CAPP. *Int J Prod Res* 33(1):17–39
106. Ji P, Xue JB (2002) Extending the algebraic method to identify dimensional chains for angular tolerance charting. *Int J Prod Res* 40(7):1597–1612
107. Ji P, Xue JB (2006) CCATA—a computer-aided angular tolerance charting system. *Proc Inst Mech Eng Part B-J Eng Manuf* 220(6):883–892
108. Joo J, Yi GR, Cho HB et al (2001) Dynamic planning model for determining cutting parameters using neural networks in feature-based process planning. *J Intell Manuf* 12(1):13–29
109. Joshi S, Chang TC (1990) Feature-extraction and feature based design approaches in the development of design interface for process planning. *J Intell Manuf* 1(1):1–15
110. Kang SS, Park DH (2002) Application of computer aided process planning system for non-axisymmetric deep drawing products. *J Mater Process Technol* 124(1–2):36–48
111. Khoshnevis B, Sormaz DN, Park JY (1999) An integrated process planning system using feature reasoning and space search-based optimization. *IIE Trans* 31(7):597–616
112. Kim C, Park YS, Kim JH et al (2002) A study on the development of computer-aided process planning system for electric product with bending and piercing operations. *J Mater Process Technol* 130:626–631
113. Kim IH, Cho KK (1994) Integration of feature recognition and process planning functions for turning operation. *Comput Ind Eng* 27(1–4):107–110
114. Kim SY, Choi WJ, Park SY (2007) Spring-back characteristics of fiber metal laminate (glare) in brake forming process. *Int J Adv Manuf Technol* 32(5–6):445–451
115. Kruth JP, VanZeir G, Detand J (1996) Extracting process planning information from various wire frame and feature based CAD systems. *Comput Ind* 30(2):145–162
116. Kurtaran H (2008) A novel approach for the prediction of bend allowance in air bending and comparison with other methods. *Int J Adv Manuf Technol* 37(5–6):486–495
117. Laperriere L, ElMaraghy HA (2000) Tolerance analysis and synthesis using Jacobian transforms. *Annals of the CIRP* 49(1):359–362
118. Laperriere L, Kabore T (2001) Monte Carlo simulation of tolerance synthesis equations. *Int J Prod Res* 39(11):2395–2406
119. Lee DH, Kiritsis D, Xirouchakis P (2004) Iterative approach to operation selection and sequencing in process planning. *Int J Prod Res* 42(22):4745–4766
120. Lee H, Kim SS (2001) Integration of process planning and scheduling using simulation based genetic algorithms. *Int J Adv Manuf Technol* 18(8):586–590
121. Lee J, Johnson GE (1993) Optimal tolerance allotment using a genetic algorithm and truncated Monte Carlo simulation. *Comput-Aided Des* 25(9):601–611
122. Lee J, Lee Y, Kim H (2005) Decision of error tolerance in array element by the Monte Carlo method. *IEEE Trans Antennas Propag* 53(4):1325–1331
123. Lee YS, Daftari D (1996) Feature-composition approach to planning and machining of generic virtual pockets. *Comput Ind* 31(2):99–128
124. Lee YS, Daftari D (1997) Process planning and machining of generic virtual pockets by feature-composition approach. *Comput Ind Eng* 33(1–2):409–412
125. Lego O, Villeneuve F, Bourdet P (1999) Geometrical tolerancing in process planning: a tri-dimensional approach. *Proc Inst Mech Eng: J Eng Manuf D Proc Part B* 213:635–640
126. Lehtihet EA, Ranade S, Dewan P (2000) Comparative evaluation of tolerance control chart models. *Int J Prod Res* 38(7):1539–1556
127. Li B, Roy U (2001) Relative positioning of toleranced polyhedral parts in an assembly. *IIE Trans* 33(4):323–336
128. Li JY, Nee AYC, Cheok BT (2002) Integrated feature-based modelling and process planning of bending operations in progressive die design. *Int J Adv Manuf Technol* 20(12):883–895
129. Li KP, Carden WP, Wagoner RH (2002) Simulation of spring-back. *Int J Mech Sci* 44(1):103–122
130. Li W, Bai G, Zhang C et al (2000) Optimization of machining datum selection and machining tolerance allocation with genetic algorithm. *Int J Prod Res* 38(6):1407–1424

131. Li WD (2005) A web-based service for distributed process planning optimization. *Comput Ind* 56(3):272–288
132. Li WD, Ong SK, Nee AYC (2002) Hybrid genetic algorithm and simulated annealing approach for the optimization of process plans for prismatic parts. *Int J Prod Res* 40(8):1899–1922
133. Lin AC, Lin SY (1998) A volume decomposition approach to process planning for prismatic parts with depression and protrusion design features. *Int J Comput Integr Manuf* 11(6):548–563
134. Lin CY, Huang WH, Jeng MC et al (1997) Study of an assembly tolerance allocation model based Monte Carlo simulation. *J Mater Process Technol* 70(1–3):9–16
135. Lin ZC, Chang YC (1998) Determination of sash bending procedures and selection of bending tools. *Int J Comput Integr Manuf* 11(3):241–254
136. Lin ZC, Hornig JT (1998) Sheet metal products: database in support of their process planning and surface development. *Int J Comput Integr Manuf* 11(6):524–533
137. Liou FW, Suen DJ (1992) The development of a feature-based fixture process planning system for flexible assembly. *J Manuf Syst* 11(2):102–113
138. Lipson H, Shpitalni M (1998) On the topology of sheet metal parts. *J Mech Des* 120(1):10–16
139. Liu SC, Gonzalez M, Chen JG (1996) Development of an automatic part feature extraction and classification system taking CAD data as input. *Comput Ind* 29(3):137–150
140. Liu XD (2000) CFACA: component framework for feature-based design and process planning. *Comput Aided Des* 32(7):397–408
141. Liu ZK, Wang LH (2007) Sequencing of interacting prismatic machining features for process planning. *Comput Ind* 58(4):295–303
142. Lutters D, ten Brinke E, Streppel AH et al (2000) Computer aided process planning for sheet metal based on information management. *J Mater Process Technol* 103(1):120–127
143. Ma YS, Britton GA, Tor SB et al (2004) Design of an feature-object-based mechanical assembly library. *Comput-Aided Des Appl* 1(1–4):397–403
144. Ma YS, Tang SH, Chen G (2007) A fine-grain and feature-oriented product database for collaborative engineering. In: *Collaborative product design & manufacturing methodologies and applications*. Springer, England, pp 109–136
145. Ma YS, Tong T (2003) Associative feature modeling for concurrent engineering integration. *Comput Ind* 51(1):51–71
146. Ma YS, Tong T (2004) An object oriented design tool for associative cooling channels in plastic injection mold. *Int J Adv Manuf Technol* 23:79–86
147. Ma YS, Tor SB, Britton GA (2003) The development of a standard component library for plastic injection mould design using an object oriented approach. *Int J Adv Manuf Technol* 22(9–10):611–618
148. Mackerle J (2004) Finite element analyses and simulations of sheet metal forming processes. *Eng Comput* 21(7–8):891–940
149. Makinouchi A (1996) Sheet metal forming simulation in industry. *J Mater Process Technol* 60(1–4):19–26
150. Manarvi IA, Juster NP (2004) Framework of an integrated tolerance synthesis model and using FE simulation as a virtual tool for tolerance allocation in assembly design. *J Mater Process Technol* 150(1–2):182–193
151. Markus A, Vancza J, Kovacs A (2002) Constraint-based process planning in sheet metal bending. *CIRP Annals-Manuf Technol* 51(1):425–428
152. Marri HB, Gunasekaran A, Grieve RJ (1998) Computer-aided process planning: a state of art. *Int J Adv Manuf Technol* 14(4):261–268
153. Martino TD, Falcidieno B, Hassinger S (1998) Design and engineering process integration through a multiple view intermediate modeler in a distributed object-oriented system environment. *Comput Aided Des* 30(6):437–452
154. McCormack AD, Ibrahim RN (2002) Process planning using adjacency-based feature extraction. *Int J Adv Manuf Technol* 20(11):817–823
155. Namboothiri VNN, Shunmugam MS (1998) Function-oriented form evaluation of engineering surfaces. *Precis Eng* 22(2):98–109
156. Nguyen THM, Duou JR, Kruthc JP (2005) A framework for automatic tool selection in integrated CAPP for sheet metal bending. In: *Proceedings of the 11th International Conference on Sheet Metal, SHEMET 2005*. Erlangen, Germany
157. Oh SC, Kim IH, Cho KK (2003) A method for automatic tolerance charting in a process planning. *Int J Ind Eng—Theory Appl Pract* 10(4):400–406
158. Ong SK, De Vin LJ, Nee AYC, Kals HJJ (1997) Fuzzy set theory applied to bend sequencing for sheet metal bending. *J Mater Process Technol* 69(1–3):29–36
159. Parente MPL, Valente RAF, Jorge RMN et al (2006) Sheet metal forming simulation using EAS solidshell finite elements. *Finite Elem Anal Des* 42(13):1137–1149
160. Park DH, Kang SS, Park SB (2002) A surface area calculation and CAPP system for non-axisymmetric deep drawing products. *Int J Adv Manuf Technol* 20(1):31–38
161. Patil L, Pande SS (2002) An intelligent feature-based process planning system for prismatic parts. *Int J Prod Res* 40(17):4431–4447
162. Pearce E, Parkinson AR, Chase KW (2004) Tolerance analysis and design of nesting forces for exactly constrained mechanical assemblies. *Res Eng Des-Theory Appl Concurr Eng* 15(3):182–191
163. Portman VT (1995) Modelling spatial dimensional chains for CAD/CAM applications. In: *Proceedings of the 4th CIRP Design Seminar on Computer-Aided Tolerancing*, pp 71–85
164. Portman VT (1995) Modelling spatial dimensional chains for CAD/CAM applications. In: *Proceedings of the 4th CIRP Design Seminar on Computer-Aided Tolerancing*. Tokyo, Japan, pp 71–85
165. Portman VT, Shuster VG (1987) Computerized synthesis of a theoretical model of a three-plane dimension chain. *Sov Eng Res* 7:57–60
166. Prabhakaran G, Asokan P, Rajendran S (2005) Sensitivity-based conceptual design and tolerance allocation using the continuous ants colony algorithm (CACO). *Int J Adv Manuf Technol* 25(5–6):516–526
167. Prabhakaran G, Asokan P, Ramesh P (2004) Genetic algorithm-based optimal tolerance allocation using a least-cost model. *Int J Adv Manuf Technol* 24(9–10):647–660
168. Radin B, Shpitalni M, Hartman I (1997) Two-stage algorithm for determination of the bending sequence in sheet metal products. *J Mech Des* 119:259–266
169. Raman R, Marefat MM (2004) Integrated process planning using tool/process capabilities and heuristic search. *J Intell Manuf* 15(2):141–174
170. Ramana KV, Rao PVM (2004) Data and knowledge modeling for design-process planning integration of sheet metal components. *J Intell Manuf* 15(5):607–623
171. Rao YQ, Huang G, Li PG et al (2007) An integrated manufacturing information system for mass sheet metal cutting. *Int J Adv Manuf Technol* 33(5–6):436–448
172. Reddy SVB, Shunmugam MS, Narendran TT (1999) Operation sequencing in CAPP using genetic algorithms. *Int J Prod Res* 37(5):1063–1074
173. Regli WC, Gupta SK, Nau DS (1995) Extracting alternative machining features: an algorithmic approach. *Res Eng Des-Theory Appl Concurr Eng* 7(3):173–192
174. Regli WC, Gupta SK, Nau DS (1997) Towards multiprocessor feature recognition. *Comput Aided Des* 29(1):37–51

175. Requicha AAG (1993) Mathematical definitions of tolerance specifications. *Manuf Rev* 6(4):269–274
176. Rico JC, Gonzalez JM, Mateos S et al (2003) Automatic determination of bending sequences for sheet metal parts with parallel bends. *Int J Prod Res* 41(14):3273–3299
177. Robert CP, Casella G (2004) Monte Carlo statistical methods. Springer Verlag, New York
178. Roy U, Liu CR, Woo TC (1991) Review of dimensioning and tolerancing: representation and processing. *CAD-Comput-Aided Des* 23:466–483
179. Samuel GL, Shunmugam MS (1999) Evaluation of straightness and flatness error using computational geometric techniques. *CAD-Comput-Aided Des* 31(13):829–843
180. Samuel GL, Shunmugam MS (2003) Evaluation of circularity and sphericity from coordinate measurement data. *J Mater Process Technol* 139(1–3):90–95
181. Schuler GmbH (1998) Metal forming handbook. Springer-Verlag, Berlin Heidelberg
182. Seo HS, Kwak BM (2002) Efficient statistical tolerance analysis for general distributions using three-point information. *Int J Prod Res* 40(4):931–944
183. Shah JJ (1991) Conceptual development of form features and feature modelers. *Res Eng Des* 2(2):93–108
184. Shah JJ, Maentylae M (1995) Parametric and feature based CAD/CAM. Wiley, New York
185. Shah JJ, Rogers MT (1988) Functional requirements and conceptual design of the feature-based modeling system. *J Comput-Aided Eng* 5(1):9–15
186. Shan A, Roth RN, Wilson RJ (1999) A new approach to statistical geometrical tolerance analysis. *Int J Adv Manuf Technol* 15(3):222–230
187. Shiu BW, Apley DW, Ceglarek D et al (2003) Tolerance allocation for compliant beam structure assemblies. *IIE Trans* 35(4):329–342
188. Shiu BW, Li B, Fu XY et al (2002) Tolerance allocation of sheet metal assembly using a finite element model. *JSME Int J Ser C—Mech Syst Mach Elem Manuf* 45(1):258–266
189. Shpitalni M (1993) New concept for design of sheet metal products. *CIRP Annals-Manuf Technol* 42(1):123–126
190. Shpitalni M, Lipson H (2000) 3D conceptual design of sheet metal products by sketching. *J Mater Process Technol* 103(1):128–134
191. Shpitalni M, Radin B (1999) Critical tolerance oriented process planning in sheet metal bending. *J Mech Des* 121(1):136–144
192. Shpitalni M, Saddan D (1994) Automatic determination of bending sequence in sheet metal products. *CIRP Annals-Manuf Technol* 43(1):23–26
193. Shunmugam MS (1986) On assessment of geometric errors. *Int J Prod Res* 24(2):413–425
194. Shunmugam MS (1987) New approach for evaluation form errors of engineering surfaces. *Comput Aided Des* 19(7):368–374
195. Shunmugam MS (1988) Assessment of errors in geometrical relations. *Wear* 128(2):179–188
196. Shunmugam MS (1991) Criteria for computer-aided form evaluation. *J Eng Ind, trans ASME* 113(2):233–238
197. Shunmugam MS, Kannan TR, Patel SV (2002) Feature recognition from orthographic drawings for sheet metal components. *Int J Ind Eng - Appl Pract* 9(4):408–417
198. Shunmugam MS, Mahesh P, Reddy SVB (2002) A method of preliminary planning for rotational components with c-axis features using genetic algorithm. *Comput Ind* 48(3):199–217
199. Singh DKJ, Jebaraj C (2005) Feature-based design for process planning of machining processes with optimization using genetic algorithms. *Int J Prod Res* 43(18):3855–3887
200. Singh PK, Jain SC, Jain PK (2003) Tolerance analysis of mechanical assemblies using Monte Carlo simulation. *Int J Ind Eng - Appl Pract* 10(2):188–196
201. Singh R, Sekhon GS (2005) PROPLAN: an expert system for optimal planning of sheet metal operations. *J Mater Process Technol* 166(2):307–312
202. Sitaraman SK, Kinzel GL, Altan T (1991) A knowledge-based system for process sequence design in axisymmetrical sheet metal forming. *J Mater Process Technol* 25(3):247–271
203. Skowronski VJ, Turner JU (1997) Using Monte Carlo variance reduction in statistical tolerance synthesis. *CAD—Comput-Aided Des* 29(1):63–69
204. Smith JS, Cohen PH, Davis JW et al (1992) Process plan generation for sheet metal parts using an integrated feature-based expert system approach. *Int J Prod Res* 30(5):1175–1190
205. Srinivasan M, Sheng P (1999) Feature-based process planning for environmentally conscious machining—part 1. Microplanning. *Robot Comput-Integr Manuf* 15(3):257–270
206. Srinivasan M, Sheng P (1999) Feature-based process planning for environmentally conscious machining—part 2. Macroplanning. *Robot Comput-Integr Manuf* 15(3):271–281
207. Streppel AH, Kals HJJ (1994) Planning of activities, resources and technology for sheet metal components: PART-S. In: *Proceedings of the 3rd International Conference on Automation Technology (Automation 94)*, Taipei, pp 193–200
208. Streppel T, Lutters E, ten Brinke E et al (2000) Process planning for sheet metal parts based on information management. *Int J Prod Res* 38(18):4701–4716
209. Subrahmanyam S, Wozny M (1995) An overview of automatic feature-recognition techniques for computer-aided process planning. *Comput Ind* 26(1):1–21
210. Sun GP, Sequin CH, Wright PK (2001) Operation decomposition for free form surface features in process planning. *Comput Aided Des* 33(9):621–636
211. Taguchi G, Elsayed EA, Hsiang T (1989) Quality engineering in production systems. McGraw-Hill, New York
212. Tang DB, Gao BH (2007) Feature-based metal stamping part and process design. Part I: stampability evaluation. *Int J Prod Res* 45(12):2673–2695
213. Tang DB, Gao BH (2007) Feature-based metal stamping part and process design. Part II: stamping process planning. *Int J Prod Res* 45(13):2997–3015
214. Tang DB, Zheng L, Li ZZ (2001) An intelligent feature based design for stamping system. *Int J Adv Manuf Technol* 18:193–200
215. Teissandier D, Couetard Y, Gerard A (1998) Three dimensional functional tolerancing with proportioned assemblies clearance volume: application to setup planning. In: *Geometric design tolerancing: theories, standards and applications. Proceedings of the 5th CIRP Seminar on Computer-Aided Tolerancing*. Toronto, Canada, pp 171–182
216. Teissandier D, Couetard Y, Gerard A (1999) A computer aided tolerancing model: proportioned assembly clearance volume. *Comput-aided Des* 31(13):805–817
217. Tekaslan O, Gerger N, Seker U (2008) Determination of spring-back of stainless steel sheet metal in “V” bending dies. *Mater Des* 29(2):1043–1050
218. Tekkaya AE (2000) State-of-the-art of simulation of sheet metal forming. *J Mater Process Technol* 103(1):14–22
219. Thanapandi CM, Walairacht A, Ohara S (2001) Multicomponent genetic algorithm for generating best bending sequence and tool selection in sheet metal parts. In: *Proceedings of IEEE International Conference on Robotics and Automation*, 1, pp 830–835
220. Thanapandi CM, Walairacht A, Periasamy T et al (2002) Preprocessor to improve performance of GA in determining

- bending process for sheet metal industry. In: Lecture notes in artificial intelligence, 2366. Springer, pp 362–373
221. Thimm G, Britton GA, Fok SC (2004) A graph theoretic approach linking design dimensioning and process planning. Part 1: designing to process planning. *Int J Adv Manuf Technol* 24(3–4):261–271
 222. Thimm G, Britton GA, Fok SC (2004) A graph theoretic approach linking design dimensioning and process planning. Part 2: design heuristics for rotational parts. *Int J Adv Manuf Technol* 24(3–4):272–278
 223. Thimm G, Britton GA, Whybrew K (2001) Optimal process plans for manufacturing and tolerance charting. *Proc Inst Mech Eng, Part B, J Eng Manuf* 215(B8):1099–1105
 224. Torvinen SJ, Salminen K, Vasek L (1991) Integration of a CIM tool management system to an intelligent feature-based process planning system. *Comput ind* 17(2–3):207–216
 225. Trappey AJC, Lai CS (1995) A data representation scheme for sheet metal parts: expressing manufacturing features and tolerance requirements. *J Manuf Syst* 14(6):393–405
 226. Tsang JP, Brissaud D (1989) A feature-based approach to process planning. In: *Proceedings of ASME Computers in Engineering Conference 1*, pp 419–430
 227. Uzsoy R, Ramcharan DJ, Martinvega LA (1991) An experimental expert system for process planning of sheet metal parts. *Comput Ind Eng* 20(1):59–69
 228. Vancza J, Markus A (1993) Features and the principle of locality in process planning. *Int J Comput Integr Manuf* 6(1–2):126–136
 229. Vandenbrande JH, Requicha AAG (1993) Spatial reasoning for the automatic recognition of machinable features in solid models. *IEEE Trans Pattern Anal Mach Intell* 15(12):1269–1285
 230. Varghese P, Braswell RN, Wang B et al (1996) Statistical tolerance analysis using FRPDF and numerical convolution. *Comput Aided Des* 28(9):723–732
 231. Varghese P, Zhang C, Wang HP (1996) Geometric tolerance analysis with vectorial tolerancing. *Eng Des Autom* 2:127–139
 232. Venkaiah N, Shunmugam MS (2007) Evaluation of form data using computational geometric techniques. Part I: circularity error. *Int J Mach Tools Manuf* 47(7–8):1229–1236
 233. Venkaiah N, Shunmugam MS (2007) Evaluation of form data using computational geometric techniques. Part II: cylindricity error. *Int J Mach Tools Manuf* 47(7–8):1237–1245
 234. Verlinden B, Cattrysse D, Van Oudheusden D (2007) Integrated sheet-metal production planning for laser cutting and bending. *Int J Prod Res* 45(2):369–383
 235. Villeneuve F, Lego O, Landon Y (2001) Tolerancing for manufacturing: a three-dimensional model. *Int J Prod Res* 39(8):1625–1648
 236. Villeneuve F, Vignat F (2003) 3D synthesis of manufacturing tolerances using a sdt approach. In: *The Eighth CIRP International Seminar on Computer Aided Tolerancing*. Charlotte, North Carolina, pp 279–290
 237. Vosniakos GC, Segredou I, Giannakakis T (2005) Logic programming for process planning in the domain of sheet metal forming with progressive dies. *J Intell Manuf* 16(4–5):479–497
 238. Wagener HW (1997) New developments in sheet metal forming: sheet materials, tools and machinery. *J Mater Process Technol* 72(3):342–357
 239. Wang CH, Bourne DA (1997) Design and manufacturing of sheet-metal parts: using features to add process planning and resolve manufacturability problems. *Robot Comput Integr Manuf* 13(3):281–294
 240. Wang GG, Xie SQ (2005) Optimal process planning for a combined punch-and-laser cutting machine using ant colony optimization. *Int J Prod Res* 43(11):2195–2216
 241. Wang H-P, Li J-K (1991) *Computer-aided process planning*. Elsevier Science Publisher, The Netherlands
 242. Wang L, Jin W, Feng HY (2006) Embedding machining features in function blocks for distributed process planning. *Int J Comput Integr Manuf* 19(5):443–452
 243. Wang LF, Chen ZY, Li CX et al (2006) Numerical simulation of the electromagnetic sheet metal bulging process. *Int J Adv Manuf Technol* 30(5–6):395–400
 244. Wang Y, Zhai WJ, Yang LP et al (2007) Study on the tolerance allocation optimization by fuzzy-set weight center evaluation method. *Int J Adv Manuf Technol* 33(3–4):317–322
 245. Wierda LS (1990) Design-oriented cost information: the need and the possibilities. *J Eng Des* 1(2):147–167
 246. Wilson PR, Pratt PR (1988) *A taxonomy of features for solid modeling*. Geometric modeling for CAD applications. Elsevier Science Publishers, The Netherlands, In
 247. Wirtz A (1991) Vectorial tolerancing: a basic element for quality control. In: *Computer-aided tolerancing: Proceedings of CIRP Seminars*. Penn State, USA, pp 115–127
 248. Wittwer JW, Chase KW, Howell LL (2004) The direct linearization method applied to position error in kinematic linkages. *Mech Mach Theory* 39(7):681–693
 249. Wong FSY, Chuah KB, Venuvinod PK (2006) Automated inspection process planning: algorithmic inspection feature recognition, and inspection case representation for CB. *Robot Comput-Integr Manuf* 22(1):56–68
 250. Wong TN, Siu SL (1995) A knowledge-based approach to automated machining process selection and sequencing. *Int J Prod Res* 33:3465–3484
 251. Wong TN, Wong KW (1995) A feature-based design system for computer aided process planning. *J Mater Process Technol* 52(1):122–132
 252. Woo Y, Wang E, Kim YS et al (2005) A hybrid feature recognizer for machining process planning systems. *CIRP Annals - Manuf Technol* 54(1):397–400
 253. Xiang W, Chuen CW, Wong CM et al (2002) A generative feature-based CAPP/CNC system for hydraulic manifold blocks. *Int J Adv Manuf Technol* 19(11):805–811
 254. Xie SQ, Xu X (2006) A STEP-compliant process planning system for sheet metal parts. *Int J Comput Integr Manuf* 19(6):627–638
 255. Xue JB, Ji P (2004) Process tolerance allocation in angular tolerance charting. *Int J Prod Res* 42(18):3929–3945
 256. Xue JB, Ji P (2005) Tolerance charting for components with both angular and square shoulder features. *IIE Trans* 37(9):815–825
 257. Yamashita M, Hattori T, Nishimura N (2007) Numerical simulation of sheet metal drawing by Maslennikov's technique. *J Mater Process Technol* 187:192–196
 258. Yang YN, Parsaei HR, Leep HR (2001) A prototype of a feature-based multiple-alternative process planning system with scheduling verification. *Comput Ind Eng* 39(1–2):109–124
 259. Zhang C, Luo J, Wang B (1999) Statistical tolerance synthesis using distribution function zones. *Int J Prod Res* 37(17):3995–4006
 260. Zhang HC, Huang SH, Mei J (1996) Operational dimensioning and tolerancing in process planning: setup planning. *Int J Prod Res* 34(7):1841–1858
 261. Zhang SG, Ajmal A, Wootton J et al (2000) A feature-based inspection process planning system for coordinate measuring machine (CMM). *J Mater Process Technol* 107(1–3):111–118
 262. Zheng JQ, Wang YL, Li ZG (2007) KBE-based stamping process paths generated for automobile panels. *Int J Adv Manuf Technol* 31(7–8):663–672
 263. Zhou F, Kuo TC, Huang SH et al (2002) Form feature and tolerance transfer from a 3D model to a setup planning system. *Int J Adv Manuf Technol* 19(2):88–96