

# A study on synergy of multiple crossover operators in a hierarchical genetic algorithm applied to structural optimisation

Carlos Conceição António

Received: 17 August 2006 / Revised: 15 December 2007 / Accepted: 2 April 2008 / Published online: 7 May 2008  
© Springer-Verlag 2008

**Abstract** Development of crossover operators is based on three different mechanisms: mating selection mechanism, offspring generation mechanism and offspring selection mechanism. Most crossover operators are able to get exploration or exploitation of the domain depending on the way they handle the current diversity of the population. Each crossover operator directs the search towards a different region in the neighbourhood of the parents. The quality of the elements belonging to the visited region depends on the particular problem to be solved. This is confirmed by the well known No Free Lunch (NFL) theorems. The simultaneous use of diverse crossover operators on the population may induce more efficient algorithms. The aim of this paper is to analyse and to study complementary properties resulting from synergy effects using several crossover operators in particular for a hierarchical genetic algorithm. The reached improvements using multiple crossover operators will be analysed through some standard optimisation examples of hybrid composite structures.

**Keywords** Hierarchical genetic algorithm · Multiple crossovers · Synergy effects · Structural optimisation

## 1 Introduction

Crossover operator in Genetic Algorithms has been referred as the most important operator in genetic

search and its individual properties have been investigated extensively (Murata and Ishibuchi 1996; Spears 1995; Hong et al. 1995; Aizawa et al. 1998; Eiben et al. 1998; Yoon and Moon 2002). Crossover operators generate new solutions by blending two current solutions. In general the action of the crossover operator is complementary to the mutation operator producing a synergy due to their different style of solution space traversal associated with crossover operators. Murata and Ishibuchi (1996) investigated the performance of several crossover and mutation operators and they observed that the combination of the best crossover and the best mutation did not give the best performance among all combinations. The same researchers observed that there exist positive and negative effects resulting from the combination of different crossovers and mutation operators.

On the other hand, different crossover operators have different behaviour over the solution space. Some researchers examined the synergy produced by combining different styles of traversal of solution space. For example Spears (1995) proposed an adaptive strategy based on two different crossovers. Two-point crossover and uniform crossover were applied at a specific change rate with benefit to the best-performing crossover operator. Spears observed that the behaviour was intermediate between the two GA using each individual crossover operators without synergy effects. Nevertheless, Hong et al. (1995) using the same crossovers but different strategies verified the synergy of multiple crossovers. This fact shows that synergy depends on the adopted strategy of combining the action of multiple crossover operators during the evolutionary process.

Several studies have revealed synergies using multiple crossover operators (Aizawa et al. 1998; Eiben

---

C. Conceição António (✉)  
Faculty of Engineering, University of Porto,  
4200-465, Porto, Portugal  
e-mail: cantonio@fe.up.pt

et al. 1998; Yoon and Moon 2002). However, there is not yet a relevant study in the literature covering structural optimisation applications. This paper is a first study of synergy using multiple crossover operators in the area of structural optimisation. A hierarchical genetic algorithm is used to present the synergy effects of the multiple crossover operators' action and how their different traversals on design space influence the genetic search performance.

## 2 The crossover operator

Early on combination was the most important task for developing the crossover operator, i.e., random parts (schemata) of genetic material from two parents are combined to originate an offspring. From this point of view the goal of crossover operator is to share information between chromosomes.

The above concept is a consequence of the original Schema Theorem or the Fundamental Theorem of Genetic Algorithms proposed by Holland (1975) where the focus is on implicit parallelism and ideal sampling of schemata. Today the analysis based on Scheme Theorem is overtaken due to the common use of elitist strategies, heuristic rules, local optimisers and different schemes of parent selection. This fact implies the identification of recombination mechanisms and a taxonomy analysis to understand the proposals for designing crossover operators.

### 2.1 The mechanisms of recombination

The exchange of structured data performed by the crossover operator is based on three different mechanisms:

- *Mating selection mechanism* (MSM). This mechanism defines the process in which the chromosomes are mated before applying crossover on them. Although, the most common procedure randomly chooses the parents other approaches have been proposed. For example, the elitist selection (Conceição António and Lhate 2003) and the age-based selection will be used in this work (Conceição António 2006).
- *Offspring generation mechanism* (OGM). Production of new chromosomes from a set of parents selected by MSM is carried out by an appropriate recombination scheme. This mechanism enables the genetic material to be transferred from parents to offspring. Different schemes have been proposed and all proposed OGMs for binary coding may be adapted to work with real coding. In this later case the value of the gene corresponding to a position in the offspring is obtained by combining the values of the genes of the parents in that same position (Herrera et al. 1998).
- *Offspring selection mechanism* (OSM). Departing from the offspring generated for each set of parents this mechanism chooses the individuals that will become population members. One of the most widely used OSMs chooses a core of best offspring to form the next population (Wright 1991; Conceição António and Lhate 2003).

Most of the crossover operators proposed in the literature is based on the generation of two offspring chromosomes per each pair of parents. However, approaches based on *multi-parent* crossover operators (Kita and Kobayashi 1999; Tsutsui et al. 1999; Deb et al. 2002) and crossover operators with *multiple descendants* (Wright 1991; Deb et al. 2002) have been investigated. One offspring per each pair of parents is considered in the present work. Any way, the OSM bounds the number of chromosomes from the offspring group to be inserted into the population.

### 2.2 Taxonomy analysis

Following the taxonomy analysis presented by Herrera et al. (2003) the crossover operators based on application to two parents are grouped as:

*Discrete crossover operators (DCOs)* A common property of these crossover operators is that the value of each gene in the offspring chromosome coincides with the value of the same gene in one of the parents. To obtain the gene values of the offspring from the genes of parents there is no numerical transformation. It considers the two-point and uniform crossover operators (Syswerda 1989; Eshelman et al. 1989).

*Aggregation based crossover operators (ABCOs)* This category of crossovers groups operators that use an aggregation function to combine numerically the values of the genes of the parents to generate the value of the offspring genes (Michallicewicz et al. 1996).

*Neighbourhood-based crossover operators (NBCOs)* In this group of crossovers the offspring genes are obtained from intervals defined in neighbourhoods associated with the genes of the parents throughout probability distribution functions. Examples of NBCOs are BLX- $\alpha$ , simulated binary crossover and fuzzy recombination (Voigt et al. 1995), which are based on uniform, polynomial and triangular probability distributions, respectively.

### 3 Multiple crossover operators

The efficiency of the crossover operator is driven by the relationship between the biased combination related to its style of traversal solution space and the nature of the problem to be solved. Thus, some schemes of crossover are more suitable to solve certain problems than others at any stage of the genetic search within the same problem. This is in agreement with the *no free lunch* (NFL) theorems (Wolpert and Macready 1997).

Following the above ideas some authors (Herrera and Lozano 2000; Yoon and Moon 2002) investigated the synergy obtained by combining different styles of search associated with the use of several crossover operators. Their objective was to investigate if a combination of crossovers performs better than the best single crossover. From this research synergetic effects can be reached through the following crossover operator groups:

*Hybrid crossover operators* These crossovers use different kinds of crossover operators to produce diverse offspring from the same parents.

*Heterogeneous distributed GAs* In these models several sub-populations evolve using independent GAs applying different mechanisms of crossover operators. These operators are differentiated according to their associated exploration and exploitation properties. They can compete or complement each other aiming the performance improvement of the genetic search.

*Adaptive crossover operator probabilities* A set of crossover operators is available, each one with an assigned probability to be used. For each reproduction event, a single operator is probabilistically selected according to the set of operator's probabilities. In addition, an adaptive process dynamically adjusts the operator's probabilities during the process of evolving a solution (Tuson and Ross 1998).

### 4 Case study: hierarchical genetic algorithm

#### 4.1 Multimodal optimisation based on species concept

In order to understand the synergy effects in structural optimisation applications, the case study of hierarchical genetic algorithm (HGA) presented by Conceição António (2006) is investigated. A genetic algorithm aiming the optimal design of composite laminate structures under non-linear behaviour is considered. The

composite laminate structures considered in this study are plates or shells reinforced with beam stiffeners.

Only one material is considered for each beam laminate used in structural reinforcement. However, different materials can be used for each ply of plate or shell laminate. This kind of composites denoted as *interply hybrid laminates* is built using at least two different materials for each laminate. Today hybrid composite laminates are commonly used in aeronautical, space and advanced industrial applications. The use of these materials has become competitive since laminate construction based on interply hybrids allows a cost reduction and an increasing performance of the mechanical properties.

Optimal design of structures made of hybrid composite materials is performed at the following levels:

- First: Optimal sizing of plate, shell or beam laminates;
- Second: Optimal material/stacking sequence of each laminate;
- Third: Optimal laminate distribution for the structure.

The above natural decomposition of the optimisation problem leads to a multimodal optimal design of hybrid composites allowing the possibility of finding several optimal solutions what is very attractive for the designer. Indeed, using a predefined material topology of the structure, i.e. fixing the laminate configuration at the second and third levels, there is an optimal solution associated to the first level that is a local minimum of the cost function. This is valid for each laminate distribution for the structure. Additional problems of finding optimal material distribution for each laminate (second level) and optimal laminate distribution on structure (third level) deal with global optimisation of composite structures. Furthermore, multiple local minima associated with the first level problem will drive the global optimisation of composite structures to search multiple global optima representing each one a different design proposal.

Following the optimisation problem formulated by Conceição António (2006), the design variables are the ply angles  $\theta$  and the ply thicknesses  $\bar{t}$  of the plate or shell laminates, the height and the width of the rectangular cross section of the beam laminate grouped in vectors  $\mathbf{h}$  and  $\mathbf{w}$  respectively. The plate or shell laminate distribution for the composite structure is denoted by vector  $\boldsymbol{\pi}$ . Each component of this last vector defines the combination material/stacking sequence for the  $j$ th plate or shell interply hybrid laminate.

A mixed code format is considered in the developed model: integer codification is used for phenotype  $\boldsymbol{\pi}$

representing the distribution of laminates (topology) on composite structure; binary codification is used for the remaining variables phenotypes.

In this work the concept of species proposed previously by the author (Conceição António 2006) is used along the evolutionary process associated to the HGA. According to that concept all individuals with the same  $\pi$  values belong to the same species. This means that genes related with  $\pi$  denote the *tag bits* to identify a species. This approach previously proposed by the author within the context of *species conservation* paradigm is based on species notion, dominance of a species and limitation of the number of members of each species at HGA sub-population level.

#### 4.2 Hierarchical genetic algorithm

The studied evolutionary process considers a sequential hierarchical relationship between sub-populations evolving in separated isolation stages followed by migration. Improvements based on the species conservation paradigm are performed to avoid genetic tendencies due to elitist strategies used in hierarchical sub-populations (Conceição António 2006). The HGA is a mixed model applying two crossover operator groups hybrid crossover operator and heterogeneous distributed GA aiming to explore the synergy of multiple crossover operators.

Most of the aspects of the proposed hierarchical genetic algorithm (HGA) are explained in reference Conceição António (2006). The considered theoretical concepts of evolution based on species conservation, a detailed discussion of appearance of new species in elite group and their life cycle, and the effects of crossover (single strategy) and mutation operators on the improvement of HGA sub-populations is made in such reference. However, a short overview of the HGA covering the essential aspects will be presented here.

In the proposed HGA model three sub-populations are arranged in a ring and they have a hierarchical relationship going from the upper level sub-population POP1 to the lower level sub-population POP3. Figure 1 shows the hierarchical topology presenting the relationship between HGA sub-populations POP1, POP2 and POP3. Each HGA sub-population has an independent evolution during a time period denoted by *isolation stage*.

After isolation a *migration stage* occurs with individuals moving towards the subsequent sub-populations in the ring net. The migration flows are identified in Fig. 1. The evolutionary time period going from sub-population POP1 to sub-population POP3 is denoted by *epoch*. Thus, multiple sequences (epochs) of

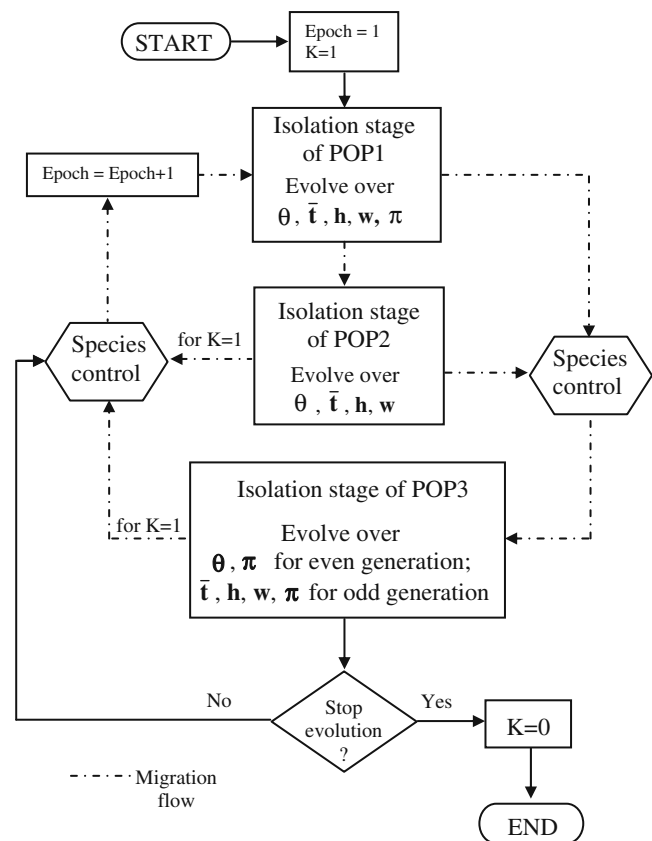

**Fig. 1** Flowchart of hierarchical genetic algorithm showing the sub-populations relationship

isolation stage followed by migration stage for each sub-population POP1, POP2 and POP3 are performed until a stopping criterion is met.

As indicated in Fig. 1 depending on the evolving sub-population, different design variables are considered in the optimisation model corresponding to active and non-active segments of each chromosome. The set of values for each non-active segment is randomly selected from the corresponding genetic part of the migrated individuals of the previous sub-populations. The use of different active segments of the chromosome corresponds to a decomposition of design space. The objective is to improve the exploration of regions of the design space associated with material anisotropy and ply thickness flexural effect at laminate level and the laminate distribution at structure level (Conceição António 2006).

The implementation of the species conservation paradigm is considered at isolation and migration stages based on the following rules:

1. Isolation stage: limitation of the number of individuals belonging to the same species;
2. Migration stage: Every single candidate for migration belongs to a different species.

---

**Hierarchical Genetic Algorithm with species conservation**

---

Initialisation of epochal evolution: Set  $e:=0$

$Epoch(1)$  is the number of generations of isolation stage for POP1

**for** POP1 **do**

Initialisation: random generation of the sub-population considering one individual per species.

**end do**

**Repeat**

**for**  $i=1$  to  $Epoch(1)$  **do** (Isolation stage)

Evolve POP1;

Only the best fitted of each species stays in the sub-population;

**end do**

$Epoch(2)$  is the number of generations of isolation stage for POP2

**for** POP2 **do**

Start migration: get the  $N_{A,2}$  best solutions from POP1;

Initialisation: random generation of the remaining sub-population.

**end do**

**for**  $i=1$  to  $Epoch(2)$  **do** (Isolation stage)

Evolve POP2;

Control the number of representative members of a species, only the best fitted of each species stays in the sub-population.

**end do**

$Epoch(3)$  is the number of generations of isolation stage for POP3

**for** POP3 **do**

Start migration: get the best solutions from POP1 and POP2 rank them considering only one per species and put the best  $N_{A,3}$  into POP3; Initialisation: random generation of the remaining sub-population.

**end do**

**for**  $i=1$  to  $Epoch(3)$  **do** (Isolation stage)

Evolve POP3;

Control the number of representative members of a species, only the best fitted of each species stays in the sub-population.

**end do**

**for** POP1 **do**

Set  $e := e + 1$

Get POP1 at epoch  $e$  to build the new sub-population POP1;

---

Start migration: get the  $N_{A,2}$  best solutions from POP2 after isolation stage;

get the  $N_{A,3}$  best solutions from POP3 after isolation stage;

Deletion of the worst solutions considering only the best fitted per species

**end do**

**until** Stopping criterion is met.

---

The evolution at isolation stage is performed applying the genetic operators in the following order: first selection, second crossover, third mutation, fourth elimination/replacement for species conservation paradigm application.

The mutation operators used here are the *implicit mutation* and *controlled mutation* and both of them are explained in Conceição António (2001, 2002, 2006). Implicit mutation considers a set of new chromosomes randomly generated and then inserted into the population. Although those chromosomes exhibit a probable fair fitness their effects on refreshing genetic material will emerge in the next generations through combination with older chromosomes and so inducing population diversity. Conversely, controlled mutation incorporates acquired data from the behaviour of the state variables of the structural system into the selection process of genes to mutate (Conceição António 2006).

Considering that a crossover operator influence study is the central investigation of this paper a detailed description will be presented in next section.

## 5 Proposal of crossover operators

### 5.1 Models overview

The main objective of this section is to propose crossover operators of different style of design space search to study the synergy effects. The crossover operators used in the present study are:

Elitist hybrid crossover with genetic improvement (EHCgi);

Elitist parameterised uniform crossover (EpUC);

Age parameterised uniform crossover (ApUC).

Table 1 shows the mechanisms of recombination of the proposed crossover operators grouping them according to taxonomy analysis. Due to the adopted elitist strategy the first two crossovers, EHCgi and EpUC, exhibit exploitation properties. Since the mechanism of recombination is based on age without elitism

**Table 1** Proposal crossover operators

Crossover	Mechanism of recombination			Taxonomy analysis
	MSM	OGM	OSM	
EHCgi	Elitist based on fitness	Hybrid crossover with genetic improvement	Elite group transferring	NBCO
EpUC	Elitist based on fitness	Uniform parameterised crossover	Elite group transferring	DCO
ApUC	Non-elitist based on age	Uniform parameterised crossover	Lethal age control + updating access constraint	DCO

*EHCgi* elitist hybrid crossover with genetic improvement  
*EpUC* elitist parameterised uniform crossover  
*ApUC* age parameterised uniform crossover

the last proposed crossover (ApUC) has exploration properties.

The EHCgi operator is based on a mixed technique where besides considering the structured stochastic exchange of genetic material from the progenitors, the local optimisation of genetic characteristic of the offspring is implemented.

From the taxonomy point of view this crossover operator is a *neighbourhood-based crossover operator* (NBCO). The two remaining crossovers are classified as *discrete crossover operators* (DCO).

### 5.2 Mating selection mechanism

The crossover operator transforms two chromosomes (parents) into a new chromosome (offspring), which genes come from both parents. Thus, the selection process of parents plays an important role in the generation of offspring genetic material. In the proposed crossover operators each pair of parents generates one offspring what is a common characteristic of MSM that will be used in the present work. Two MSMs are considered in the presented work: (1) elitist based on fitness and (2) non-elitist based on age.

#### 5.2.1 Elitist based on fitness

Since one parent comes from the elite group the adopted MSM is elitist. The proposed methodology is based on the following steps:

- Step 1: Ranking based fitness of the population.
- Step 2: The population is divided in two groups, the first one having best fitness denoted by elite and defined as

$$U = \{ \mathbf{S}_1^t, \mathbf{S}_2^t, \dots, \mathbf{S}_p^t \} \tag{1}$$

and the other one grouping the set with the worst fitness

$$L = \{ \mathbf{S}_{p+1}^t, \mathbf{S}_{p+2}^t, \dots, \mathbf{S}_{N_{pop}}^t \} \tag{2}$$

- Step 3: Parent selection based on individual fitness. The couple of parents ( $\mathbf{p}_1, \mathbf{p}_2$ ) is obtained using two independent selection processes in  $U$  and  $L$  sets. The parents  $\mathbf{p}_1$  and  $\mathbf{p}_2$  are selected as

$$\mathbf{p}_1 \in U \quad \text{and} \quad \mathbf{p}_2 \in L \tag{3}$$

An individual  $\mathbf{S}_k^t$  belonging to the  $U$  set has the following probability to be selected as parent:

$$P(\mathbf{S}_k^t) = \frac{FIT(\mathbf{S}_k^t) + F_1^t}{\sum_{k=1}^p [FIT(\mathbf{S}_k^t) + F_1^t]} \tag{4}$$

for  $k = 1, \dots, p$

where the scaling factor for the elite group  $U$  is calculate as

$$F_1^t = \begin{cases} -\mathbf{S}_p^t & \text{if } \mathbf{S}_p^t < 0 \\ 0 & \text{if } \mathbf{S}_p^t \geq 0 \end{cases} \tag{5}$$

For the  $L$  set with worst fitness, the individual probability to be selected as parent is

$$P(\mathbf{S}_k^t) = \frac{FIT(\mathbf{S}_k^t) + F_2^t}{\sum_{k=p+1}^{N_{pop}} [FIT(\mathbf{S}_k^t) + F_2^t]} \tag{6}$$

for  $k = p + 1, \dots, N_{pop}$

with the scaling factor  $F_2^t$  defined as

$$F_2^t = \begin{cases} -\mathbf{S}_{N_{pop}}^t & \text{if } \mathbf{S}_{N_{pop}}^t < 0 \\ 0 & \text{if } \mathbf{S}_{N_{pop}}^t \geq 0 \end{cases} \tag{7}$$

The selection process is repeated until the necessary couples ( $\mathbf{p}_1, \mathbf{p}_2$ ) (one per each offspring) are found.

### 5.2.2 Non-elitist based on age

A continuous model of generation of individuals was adopted for age-structured population. An enlarged population with age structure POP4 and performing in parallel with the hierarchical topology of HGA is considered in this model (Conceição António 2006). Each individual belonging to population POP4 is characterized by two parameters: *individual age* and *lethal age*. The individual age increases one unit after each generation. Any individual removed from HGA sub-populations either by elitist strategy or by finishing of isolation stage of evolution and not selected for migration, will survive in the population with age structure POP4. Furthermore, its individual age will continue increasing until removed definitively due to lethal age. More details of the connection between age structure population POP4 and HGA populations are presented in Conceição António (2006).

In the population with age structure (POP4) the MSM is conditioned by the candidate age. Assuming that population maturity and potentiality follow a Normal distribution the parent selection is probability dependent. Figure 2 presents the Normal probability density function,  $f_z(z)$ , applied to parent selection in this crossover process. Individuals with ages located at the tails of the normal density function are the youngest and the oldest of the scale, and they have a very low probability to be selected as parents. Then the reproduction rate by crossover depends on the maturity and degrades as the life cycle goes on till the end. This dynamic behaviour is fundamental in the species conservation context (Conceição António 2006).

### 5.3 Offspring Generation Mechanism (OGM)

Two OGMs are considered in the presented work: (1) hybrid crossover with genetic improvement and (2) uniform parameterised crossover.

#### 5.3.1 Hybrid crossover with genetic improvement

The hybrid crossover with genetic improvement is supported by commonality-based crossover framework and it is based on heuristics linked to optimal design of structures (Conceição António and Lhate 2003). According to the goal of genetic algorithms, information from good parent solutions is exploited to find better solutions. The concept of commonality-based crossover suggests that search must be driven in regions of neighbourhoods associated to parents and using a local optimiser.

The Hamming distance concept is used in the local optimisation process to define a trajectory of search and a local fitness is defined to rank the genetic material of the offspring candidate (Conceição António and Lhate 2003). Considering the *crossover* of chromosomes or *strings* defined in the Hamming space  $\mathbf{Z}_2^l$ , any offspring generated by two parents is located, from the genetic point of view, on a path that connects one parent to another. This can be established introducing the concept of *intermediate vector* defined as follows:

**Proposition** *The following definitions are equivalent,*

1. *The vector  $\mathbf{z}$  defined in  $\mathbf{Z}_2^l$  is intermediate between two vectors  $\mathbf{v}$  and  $\mathbf{y}$ , written as  $\mathbf{v} \diamond \mathbf{z} \diamond \mathbf{y}$ , if and only if*

$$z_i = v_i \text{ or } z_i = y_i, \text{ for } i = 1, \dots, n \quad (8)$$

**Fig. 2** Non-elitist parent selection based on age (MSM)

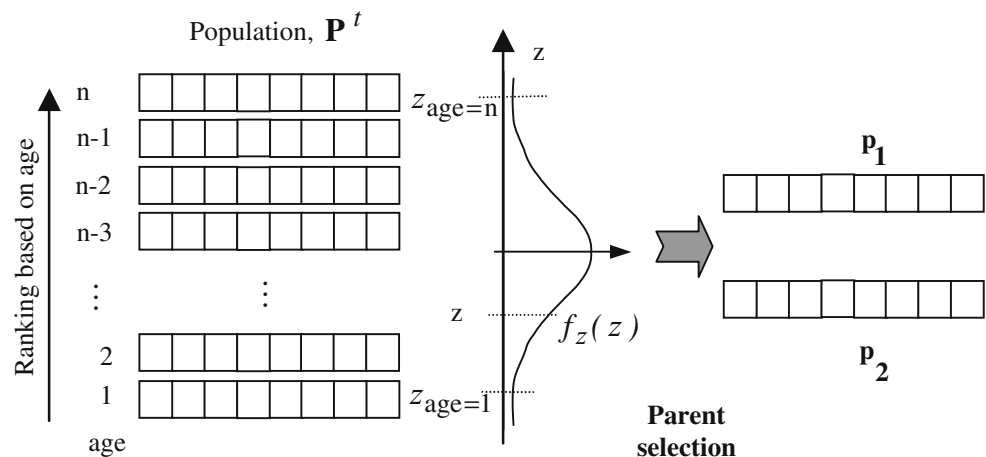

2. Defining the distance of Hamming as the distance measured between two vectors in  $\mathbf{Z}_2^n$  given by

$$d(\mathbf{v}, \mathbf{z}) = \sum_{i=1}^n |v_i - z_i|, \tag{9}$$

$\mathbf{z}$  is intermediate between  $\mathbf{v}$  and  $\mathbf{y}$  if and only if

$$d(\mathbf{v}, \mathbf{y}) = d(\mathbf{v}, \mathbf{z}) + d(\mathbf{z}, \mathbf{y}) \tag{10}$$

The above proposition clearly establishes that every offspring generated by crossover is intermediate between the parents not only in the genetic sense, but also in the sense of intermediate point of associated space, in this case the Hamming space.

The OGM of hybrid crossover with genetic improvement combination scheme performs as follows:

1. Let  $\mathbf{p}_1$  and  $\mathbf{p}_2$  be two parents selected in an independent way, being  $\mathbf{p}_1$  from the elite,  $\mathbf{U}$ , defined in (1) and  $\mathbf{p}_2$  from the group with less fitness,  $\mathbf{L}$ , defined in (2).
2. Define chromosome/solution  $\mathbf{z}_k$  intermediate to  $\mathbf{p}_1$  and  $\mathbf{p}_2$ , which genes of the active segments are obtained as follows

$$z_{k,i} = \begin{cases} p_{1,i} \leftarrow \mathbf{p}_1 \in \mathbf{U} & \text{if } \text{Unif}(0, 1) \leq P_i^{\text{cros}} \\ p_{2,i} \leftarrow \mathbf{p}_2 \in \mathbf{L} & \text{if } \text{Unif}(0, 1) > P_i^{\text{cros}} \end{cases} \tag{11}$$

where  $z_{k,i}$  denotes the string  $i$  of  $\mathbf{z}_k$  and  $P_i^{\text{cros}}$  is the crossover probability.

3. Calculate the Hamming distances defined by
 
$$d_1 = d(\mathbf{p}_1, \mathbf{z}_k) \text{ and } d_2 = d(\mathbf{p}_2, \mathbf{z}_k), \tag{12}$$
 where only the active segments of the chromosome are considered.
4. The genes of a non-active segment of the chromosome/solution  $\mathbf{z}_k$  are equal to those of the corresponding segment of the nearest parents, according to the Hamming distances,  $d_1$  and  $d_2$ , calculated on the previous step.
5. Evaluate the local fitness function  $\Phi(\mathbf{z}_k)$  for the chromosome /solution  $\mathbf{z}_k$ .
6. Repeat from step 2 to 5 until a predefined number  $N_z$  of chromosomes/solutions candidates are obtained.
7. Calculate the local solution with best fitness,  $\bar{\mathbf{z}}$ , defined as

$$\Phi_{\max}(\bar{\mathbf{z}}) = \text{Max} [\Phi(\mathbf{z}_k) \quad , \quad k = 1, \dots, N_z] \tag{13}$$

8. Take the chromosome/solution  $\bar{\mathbf{z}}$  as the offspring generated by  $\mathbf{p}_1$  and  $\mathbf{p}_2$  parents.

The most important feature of the hybrid crossover is the genetic material exchange of the parents based on local search of the best genetic characteristic for

the offspring. This local optimisation performs on the neighbourhood defined by  $\mathbf{p}_1$  and  $\mathbf{p}_2$  considering the associated Hamming space.

In the developed hybrid crossover scheme it is necessary to define the local fitness function  $\Phi(\mathbf{z}_k)$ . Since the classical formulation of genetic algorithms only uses fitness information, it is necessary, in this case, to perform the structural analysis for each solution. This can be very tedious and computationally expensive, mainly in non-linear analysis. However, the use of approximations makes the evaluation process rational from the economical point of view. Thus the local fitness function is defined as

$$\Phi(\mathbf{z}_k) = \beta_1 W(\mathbf{z}_k) + \beta_2 \tilde{U}(\mathbf{z}_k) + \Psi(\bar{\Delta}_s) \tag{14}$$

where  $\beta_1$  and  $\beta_2$  are scaling constants,  $W(\mathbf{z}_k)$  is the weight/cost of the structure,  $\tilde{U}(\mathbf{z}_k)$  is an approximation of the strain energy of the structural system and  $\Psi(\bar{\Delta}_s)$  is the constraint term related with the estimated value of the constraint violation for the offspring candidate solution  $\mathbf{z}_k$ . The weight/cost of the structure is calculated directly using the decoding values of the design variables. However, the strain energy and the constraint term depend on the state variables of the structural system. Thus, the last two terms of (10) are evaluated based on approximations and heuristic rules that can be found in Conceição António and Lhate (2003).

### 5.3.2 Parameterised uniform crossover

Using the known technique “parameterised uniform crossover” proposed by Spears and DeJong (1991) the offspring genetic material is obtained. This offspring generation mechanism (OGM) performs a multipoint combination of genes from both parents’ chromosomes (Conceição António 2001, 2002). The genetic material exchange can be implemented as follows:

1. In active segments of the chromosome, the offspring gene  $z_i$  is selected in a biased way given a probability  $P_i^{\text{cros}}$  for choosing gene  $u_i$  from the progenitor chromosome that belongs to the elite group  $\mathbf{U}$  with best fitness defined in (1). This operation can be represented as

$$z_i = \begin{cases} u_i \leftarrow \mathbf{S}_j \in \mathbf{U} & \text{if } \text{Unif}(0, 1) \leq P_i^{\text{cros}} \\ v_i \leftarrow \mathbf{S}_j \in \mathbf{L} & \text{if } \text{Unif}(0, 1) > P_i^{\text{cros}} \end{cases} \tag{15}$$

2. The genes of non-active segments of the offspring chromosome are equal to the genes of the corresponding segments in the chromosome of one of the parents selected randomly.



#### 5.4 Offspring Selection Mechanism (OSM)

The OSM is associated with the adopted strategy: (1) elite group transferring; (2) lethal age control plus updating access.

##### (a) Elite group transferring:

According to the evolutionary process for HGA sub-populations presented in Section 4 the offspring generated by the crossover operator stays in the population for at least one generation. Since at each isolation stage the evolution is based on an elitist strategy where a core of best-fitted individuals is transferred from generation into the next ones the OSM results in one of the following scenarios:

$FIT(\mathbf{z}^t) \leq FIT(\mathbf{S}_p^t)$ : In this case the  $\mathbf{z}$  offspring is eliminated from the population at the  $(t+1)$ -th generation and only the best-fitted parent has some probability of surviving in the population;

$FIT(\mathbf{z}^t) > FIT(\mathbf{S}_p^t)$ : The offspring can integrate the elite group at the  $(t+1)$ -th generation depending on the fitness ranking. Offspring and/or best-fitted parent elimination can occur. The worst fitted parent of the elite group is always eliminated.

The *survival time* of offspring in the elite group of the population depends on the *success rate* of the genetic operators to generate the best-fitted individuals. This parameter is used to measure the crossover performance that will be defined further.

##### (b) The updating access constraint and lethal age control:

The first aspect of this procedure is the integration of any individual generated by “new” into the age-structured population denoted by POP4 (Conceição António 2006). The access of individuals to this age-structured population is regulated by a lower bound constraint imposed on the fitness of the candidate. The adopted strategy defines the lower bound as a percentage of the worst individual fitness of the elite group  $FIT(\mathbf{S}_p^t)$  in HGA sub-populations at each generation as follows:

$$FIT_{\text{access}}^{t+1} \geq \alpha FIT(\mathbf{S}_p^t) \quad (16)$$

The access to age-structured population can be free if  $\alpha$  assumes an appropriate value associated for example with  $F_2^t$  in (7). Since  $FIT(\mathbf{S}_p^t)$  changes at each

generation depending on the *success rate* of the genetic operators, the access constraint is updated along the evolutionary process.

The second aspect of this procedure is that an individual assumes individual age equals to zero when it is inserted in the age-structured population. The individual age is increased by one unit at each generation and the individual survives into the age-structured population until it reaches the lethal age.

In multiple crossovers the elitist strategy based on fitness ranking elimination can coexist with the age-based structure where the elimination of an individual occurs only at lethal age. An individual with low fitness can be selected as parent in subsequent generations according to the species conservation paradigm (Conceição António 2006).

## 6 Strategies for multiple crossover applications

In this paper a study to examine the synergy effects resulting from the use of different crossovers is performed. Firstly it should be defined the concept of synergy. The definition of synergy suggested by Yoon and Moon (2002) is adopted as follows:

**Proposition** Consider two crossovers  $C1$  and  $C2$  and assume without loss of generality that crossover  $C1$  performs better than  $C2$  when used alone. If the mixing of  $C1$  and  $C2$  performs better than the sole usage of  $C1$ , we say that crossovers  $C1$  and  $C2$  have synergy.

The adopted strategies to reach the synergy effects are based on the combination of proposed crossovers applied to the isolation stage for each sub-populations of the hierarchical genetic algorithm. Table 2 shows six strategies using the proposed crossover operators presented in Section 5. The first three strategies were implemented taking advantage of exploitation characteristics of the elitist crossover. The last three strategies are based on mixed exploitation and exploration properties of the elitism combined with age-structured populations.

In the proposed strategies the synergy is reached using multiple crossover operators at the isolation stage of HGA sub-populations and using heterogeneous distributed GA performed by hierarchical topology of sub-populations.

From Table 2 it is observed the following functional properties:

- Crossover strategy 3 is a combination of crossover strategies 1 and 2;

**Table 2** Strategies of multiple crossovers for hierarchical genetic algorithm (HGA)

Crossover strategy	HGA sub-populations		
	POP1	POP2	POP3
1	EpUC	EpUC	EpUC
2	EpUC	EHCgi	EpUC
3	EpUC	[EpUC+EHCgi] <sup>2</sup>	EpUC
4a	[EpUC+ApUC] <sup>2</sup>	[EHCgi+ApUC] <sup>2</sup>	[EpUC+ApUC] <sup>2</sup>
4b	[EpUC+ApUC*] <sup>2</sup>	[EHCgi+ApUC*] <sup>2</sup>	[EpUC+ApUC*] <sup>2</sup>
5	[EpUC+EpUC+ApUC] <sup>3</sup>	[EHCgi+EHCgi+ApUC] <sup>3</sup>	[EpUC+EpUC+ApUC] <sup>3</sup>

*EHCgi* elitist hybrid crossover with genetic improvement, *EpUC* elitist parameterised uniform crossover, *ApUC* age parameterised uniform crossover with  $\alpha = 0.6$ , *ApUC\** age parameterised uniform crossover with  $\alpha = 0.95$ ,  $[ ]^n$  sequence of multiple crossovers repeated after  $n$  generations

- Crossover strategy 4 results from the combination of crossover strategy 2 and the crossover ApUC used at HGA sub-populations;
- Crossover strategy 5 is a combination of crossover strategies 2 and 4a;

**7 Results and discussion**

In order to show and to analyse synergy effects produced using multiple crossovers two structural optimisation problems are presented. Selected parameters are used to evaluate the synergetic effects of the proposed multiple crossover strategies: synergy, best fitness difference (BFD) and crossover replacement rate in elite group. These parameters will be introduced further in this section.

7.1 Cylindrical shell problem

7.1.1 Problem definition

A cylindrical shell made of laminated composite materials is considered as shown in Fig. 4. The shell is hinged on straight sides and free on its curved boundary. A central point load  $F_{max}/4 = 1$  kN is applied and only a quarter of the structure was considered for the structural optimisation problem. Ten laminates were taken into account for the structure, four laminates grouping the shell elements (from 1 to 4) and six others (from 5 to 10) grouping the beam elements. All shell laminates are symmetric and composed of six plies (Fig. 3).

The mechanical properties of the materials for ply laminate construction are presented on Table 3,

longitudinal strength,  $X$ , transversal strength,  $Y$ , and shear strength,  $S$ . Other properties listed are longitudinal Young modulus,  $E_1$ , transversal elastic modulus,  $E_2$ , shear modulus,  $G_{12}$ , Poisson’s ratio,  $\nu$ , and specific weight of the material,  $\rho$ . From Table 3 one material is selected for each ply. The pair material/stacking sequence defined by variable  $\pi_j$  is a combination of different materials for symmetric shell laminates. At least two materials must be considered for hybrid composite laminate construction. The beam laminates have six plies made of material number 2 from Table 3 and this material does not change during the optimisation process.

The optimisation problem is formulated aiming the minimization of the weight/cost of the structure  $W(\mathbf{x}, \boldsymbol{\pi})$  and the minimization of the strain energy  $U(\mathbf{x}, \boldsymbol{\pi})$ , subject to constraints related with structural integrity and with imposed service conditions as defined in Conceição António (2002, 2006). The constraints are imposed on the critical load factor and on the critical displacement, both of them associated with buckling and first ply failure. The first ply failure is determined based on Huber–Mises law (Conceição António 2002). Additionally displacement bounds can be imposed as service conditions. Using an appropriate formulation for genetic search it is intended to maximise a global fitness function FIT written as

$$FIT = \bar{C}_1 - \beta_1 W(\mathbf{x}, \boldsymbol{\pi}) - \beta_2 U(\mathbf{x}, \boldsymbol{\pi}) - \sum_{i=1}^3 \Gamma_i [\varphi_i(\mathbf{x}, \boldsymbol{\pi})] \tag{17}$$

with

$$\Gamma_i [\varphi_i(\mathbf{x}, \boldsymbol{\pi})] = \begin{cases} 0 & \text{if } \varphi_i(\mathbf{x}, \boldsymbol{\pi}) \leq 0 \\ \bar{K}_i [\varphi_i(\mathbf{x}, \boldsymbol{\pi})]^{q_i} & \text{if } \varphi_i(\mathbf{x}, \boldsymbol{\pi}) > 0 \end{cases} \quad i = 1, 2, 3 \tag{18}$$

**Fig. 3** Geometry and laminates of the cylindrical shell structure reinforced with beams

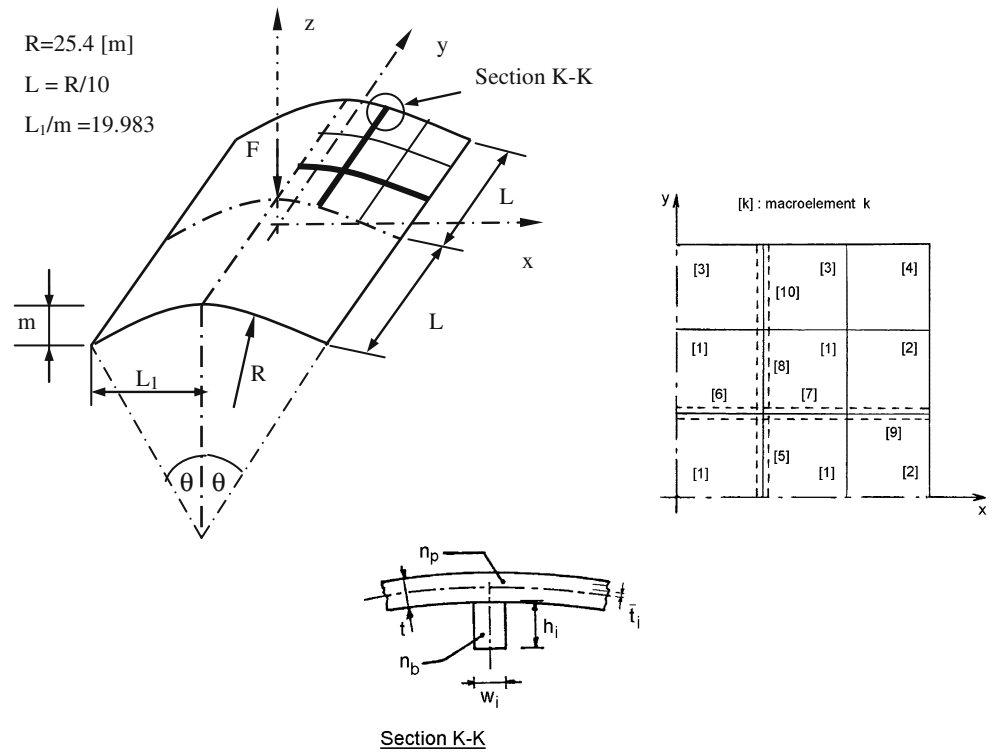

where  $\Gamma_i[\varphi_i(\mathbf{x}, \boldsymbol{\pi})]$  represents each constraint term associated with constraint  $\varphi_i(\mathbf{x}, \boldsymbol{\pi})$ , and the constants considered in (17) are  $\bar{C}_1 = 10,000$ ,  $\beta_1 = 10$  and  $\beta_2 = 1000$ . Using previously acquired acknowledgement of the structural behaviour, the constants  $\beta_i$  are defined aiming the numerical equilibrium between weight and energy terms of the fitness function (17). The constraint term defined in (18) is calculated using penalties depending on the constraint violation degree (Spears and DeJong 1991). The maximum allowed value for critical displacement of buckling and for First Ply Failure displacement is  $\bar{d}_a = 1.3 \times 10^{-1}$  m. The same value is taken for the allowable displacement at any point of the structure. The lower bound for the critical load factor is  $\bar{\lambda}_a = 0.45$ . The size constraints for the design variables are established as:

$$\begin{aligned}
 -90^\circ &\leq \theta_{i,j} \leq 90^\circ \\
 1.2 \times 10^{-3} \text{ m} &\leq \bar{t}_{i,j} \leq 2.4 \times 10^{-3} \text{ m}
 \end{aligned}$$

$$\begin{aligned}
 2.0 \times 10^{-2} \text{ m} &\leq h_j \leq 4.0 \times 10^{-2} \text{ m} \\
 5.0 \times 10^{-3} \text{ m} &\leq w_j \leq 1.5 \times 10^{-2} \text{ m}
 \end{aligned}
 \tag{19}$$

Four digits are used for binary code format of ply angle variables and three digits to codify each of the remaining variables of the constraints (19). There are 24 possible combinations of three materials for the stacking sequence  $\pi_j$  when considering six plies in the symmetric  $j$ th composite shell laminate construction and at least two materials per laminate.

All sub-populations (POP1, POP2 and POP3) of the hierarchical genetic algorithm have 15 individuals. The elite group and the mutation group have five individuals each in all sub-populations and three individuals participate in each migration flow between the three HGA sub-populations. For each HGA sub-population the isolation stage runs for six generations. In age-structured population the lethal age is equal to 15 generations. The optimal solution for this problem

**Table 3** Mechanical properties of the materials used for the composite laminate construction

Material number	$E_1$ [GPa]	$E_2$ (GPa)	$G_{12}$ (GPa)	$\nu$	$X$ (GPa)	$Y$ (GPa)	$S$ (GPa)	$\rho$ (kg/m <sup>3</sup> )
1	181.0	10.3	7.17	0.28	15.0	0.40	0.68	1,600
2	38.6	8.27	4.14	0.26	10.62	0.31	0.72	1,800
3	43.0	8.90	4.50	0.27	12.80	0.49	0.69	2,000

has been presented in a previous paper (Conceição António 2006).

### 7.1.2 Synergy analysis

Synergy is measured by gains and losses in best fitness using the proposition presented in Section 6 and can be written mathematically as

$$\text{Synergy} = \text{FIT}_{C1+C2} - \text{FIT}_{C1} \quad (20)$$

where  $\text{FIT}_{C1}$  denotes the fitness obtained with the crossover strategy C1 that performs better than C2 when used alone and  $\text{FIT}_{C1+C2}$  denotes the fitness obtained with the crossover strategy resulting from the mixing of C1 and C2.

In order to compare crossover strategies that do not result directly from the application of the synergy definition it is introduced the concept of best fitness difference (BFD) as follows

$$\text{BFD} = \text{FIT}_{S1} - \text{FIT}_{S2} \quad (21)$$

being S1 and S2 the two strategies under analysis.

The idea is to identify the independent effects of each crossover C1 and C2 and later to compare these effects with those resulting from mixed use of both crossover operators in multiple crossover strategy at isolation stages of HGA sub-populations and in heterogeneous distributed GA with the hierarchical topology.

The first example shows the synergy that is obtained by mixing crossover strategies 1 and 2. Crossover strategy 3 considers an alternate use of both crossover operators elitist parameterised Uniform Crossover (EpUC) and elitist hybrid crossover with genetic improvement (EHCgi) at sub-population POP2 level.

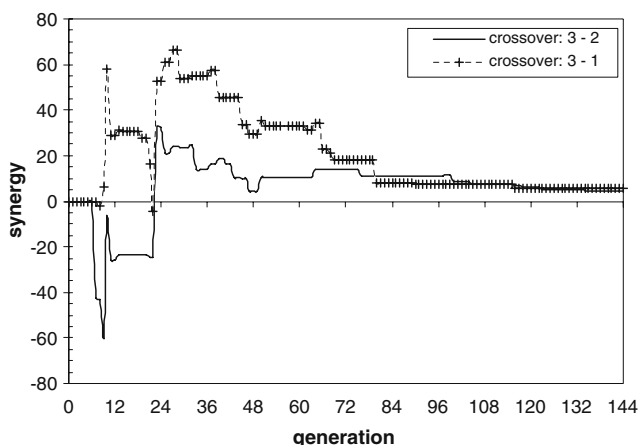

**Fig. 4** Cylindrical shell example: synergy obtained using crossover strategy 3 resulting from crossover strategies 1 and 2

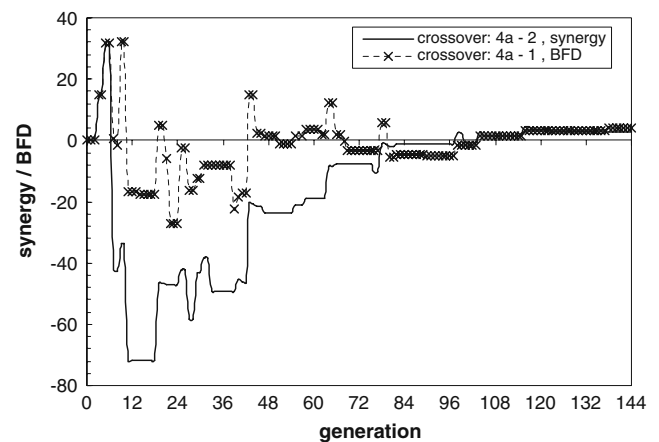

**Fig. 5** Cylindrical shell example: synergy and BFD obtained using crossover strategy 4a when compared to strategies 1 and 2

Figure 4 shows the gains and the losses of the best fitness of the algorithm using crossover strategy 3 relatively to the best fitness obtained using crossover strategy 1 and crossover strategy 2. Since the gains of crossover strategy 3 are effective in both cases after the 20th generation the obtained results show the benefits of using multiple crossovers. Only at the beginning of evolutionary process crossover strategy 3 does not have synergetic effects when compared to crossover strategy 2.

Figure 5 shows the possible synergetic effect by using the age structure (POP4) according to crossover strategy 4a ( $\alpha = 0.6$ ). Crossover strategy 4 results from the mixed use of crossover strategy 2 and age parameterised uniform crossover (ApUC) at HGA sub-populations. The ApUC is not elitist due the mating selection mechanism that is a function of individual age as explained in Section 5. Since ApUC is based on the species conservation paradigm its exploration properties are good but its exploitation capacity is fair. Then, crossover strategy 2 is better than the isolated usage of ApUC at HGA sub-populations in agreement with the comparison between crossover strategy 4a and 2 showed in Fig. 5.

According to the previous definition of synergy no positive effects are identified during the first generations. However, crossover strategy 4a recovers and the losses decrease after the 40th generation. The synergetic effects of crossover strategy 4a relatively to crossover strategy 2 are evident towards the end of evolutionary search. The explorative capacity of ApUC comes out at the end of the process.

As shown in Fig. 5, the above comments stay valid when the BFD resulting from the comparison of crossover strategy 4a with crossover strategy 1 is calculated.

**Fig. 6** Cylindrical shell example: synergy obtained using crossover strategy 5 when compared to crossover strategies 4a ( $\alpha = 0.6$ ) and 4b ( $\alpha = 0.95$ )

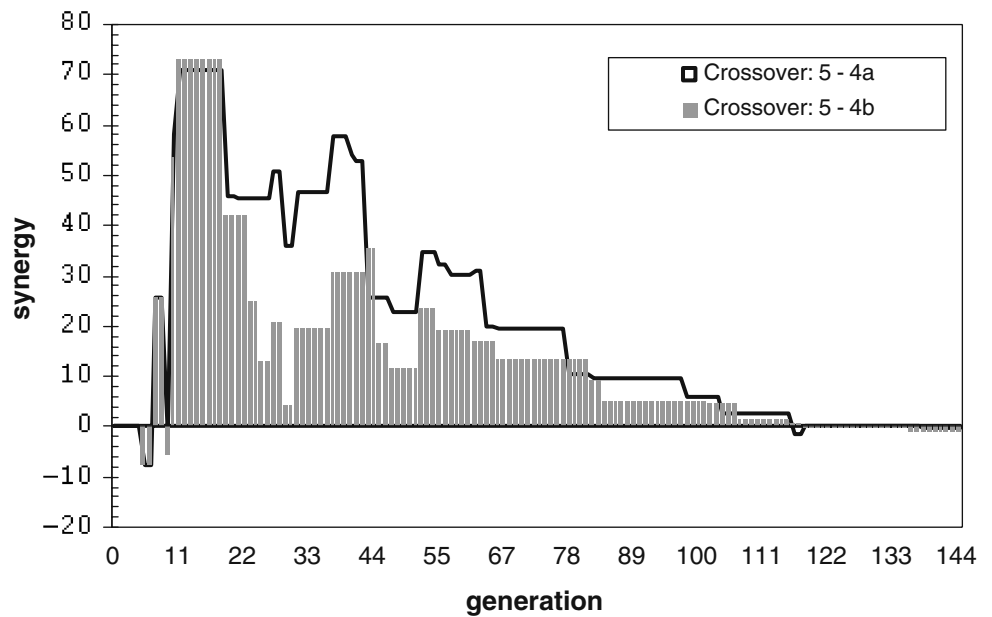

Considering that crossover strategy 5 results from the combination of crossover strategies 2 and 4a the synergy effects are observable in Figs. 6 and 7. The synergy values displayed in Fig. 6 show that crossover strategy 4b ( $\alpha = 0.95$ ) is better than crossover strategy 4a ( $\alpha = 0.6$ ). Then it seems possible to increase the synergy of crossover strategy 4 by increasing the value of the constant  $\alpha$  on the updating access constraint.

From Fig. 7 the synergy effects of crossover strategy 5 are positive compared to crossover strategies 1 and 2.

Figures 8 and 9 show the improvements in best fitness that result from the use of different strategies based on multiple crossovers and heterogeneous distributed GAs. The BFD obtained from crossover strategies 3 and 4a proves that crossover strategy 3 is better than crossover strategy 4a as shown in Fig. 8. Figure 9 presents a similar comparison between crossover strategy 3 and 5 using BFD values. Comparing the values presented in Figs. 8 and 9 and since crossover strategy 5 is related to crossover strategy 4a

**Fig. 7** Cylindrical shell example: synergy and BFD obtained using crossover strategy 5 when compared to crossover strategies 1 and 2

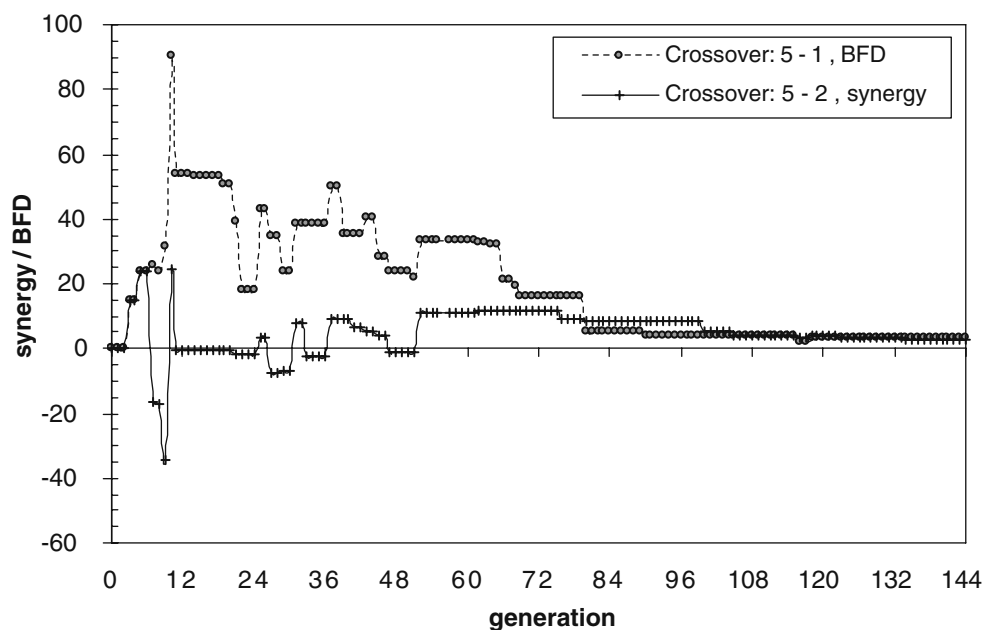

**Fig. 8** Cylindrical shell example: BFD values comparing crossover strategies 3 and 4a

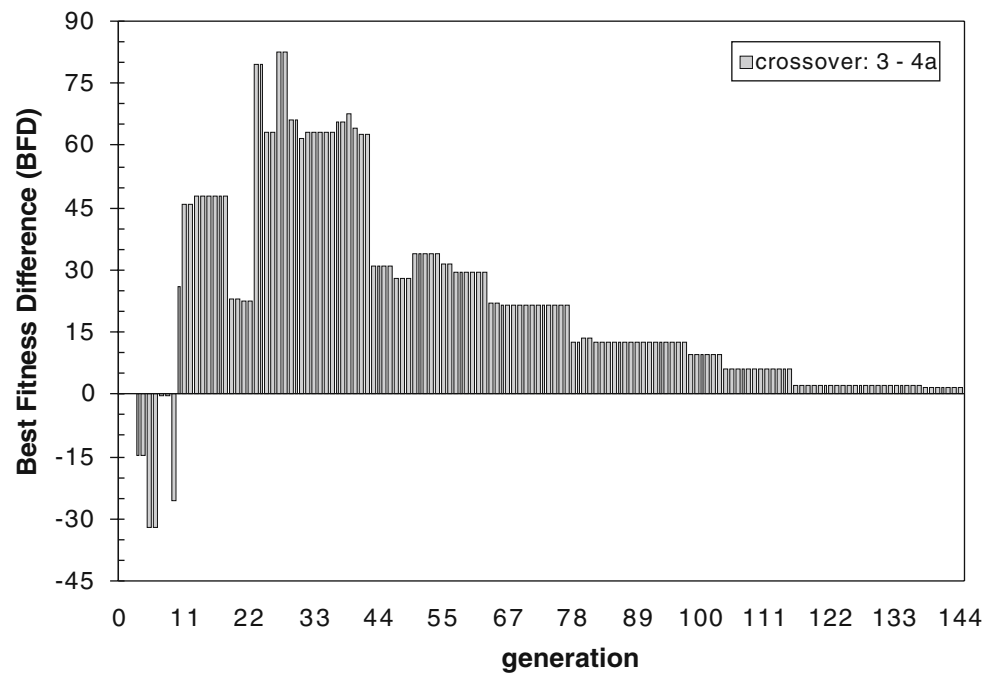

there is a clear improvement of the first one over the last one. After 50 generations the difference between crossover strategies 3 and 5 is not important. This means that a synergy effect can be reached without making use of pure elitism.

Finally it can be concluded that synergy depends on the frequency of interaction between different crossover operators inside the HGA. The application of numerical models based on multiple crossover usage in GA is an important challenge for users and designers.

### 7.1.3 Crossover replacement rate in elite group

This analysis parameter measures the success rate of replacement of at least one individual of the elite group by solutions obtained from crossover (offspring). The efficiency of the crossover strategy is analysed when the best offspring solution from crossover is compared with the worst fitted individual of the elite group. This last one is the best candidate to be eliminated in the next generation. The replacement rate of the elite group is

**Fig. 9** Cylindrical shell example: BFD values comparing crossover strategies 3 and 5

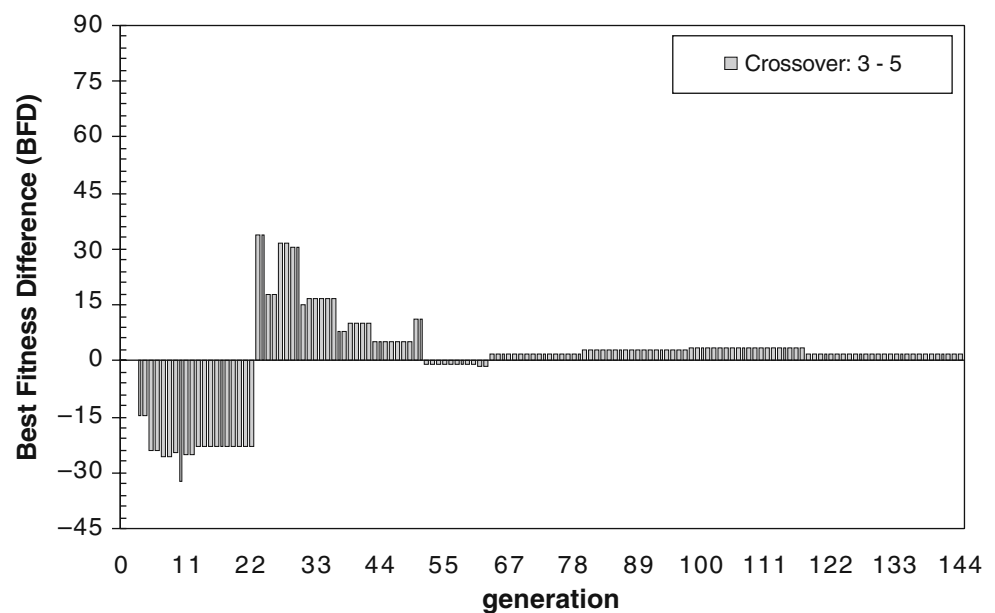

a parameter associated with the quality of the solutions obtained from crossover and it is defined after  $n$  generations as

$$\text{replacem\_rate}(n) = \frac{\sum_{i=1}^n \text{event}(i)}{n} \times 100, (\%) \quad (22)$$

where  $\text{event}(i)$  is equal 1 for success replacement and otherwise is equal 0.

Figure 10 shows the results obtained using synergy related crossover strategies 2 and 3 according to the definition given in Section 6. Similar analysis is shown in Fig. 11 for crossover strategies 4b and 5.

In Fig. 10, after an initialization period the rate is kept above 40% for both crossover strategies 2 and 3 during the first 60 generations. The rate decreases at the end of the evolutionary process with a short 5% difference between the two crossover strategies showing final values of 30% and 25%.

Different behaviours are observed in Fig. 11 for crossover strategies 4b and 5. After a short period of initialization the replacement rate for crossover strategy 5 is located in the interval 30–40% for around 90 generations decaying to 23% at the end of the evolutionary process. The replacement rate for crossover

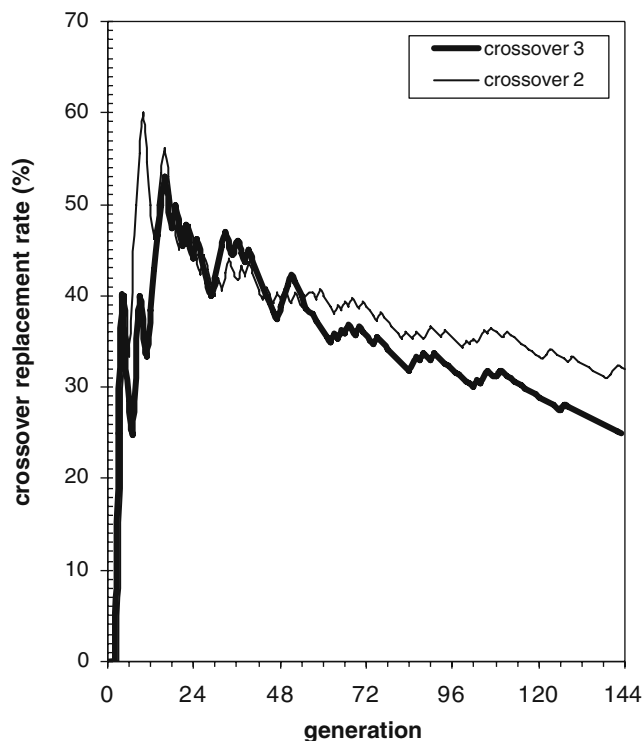

**Fig. 10** Cylindrical shell example: Crossover replacement rate in elite group (%) for synergy related with crossover strategies 3 and 2

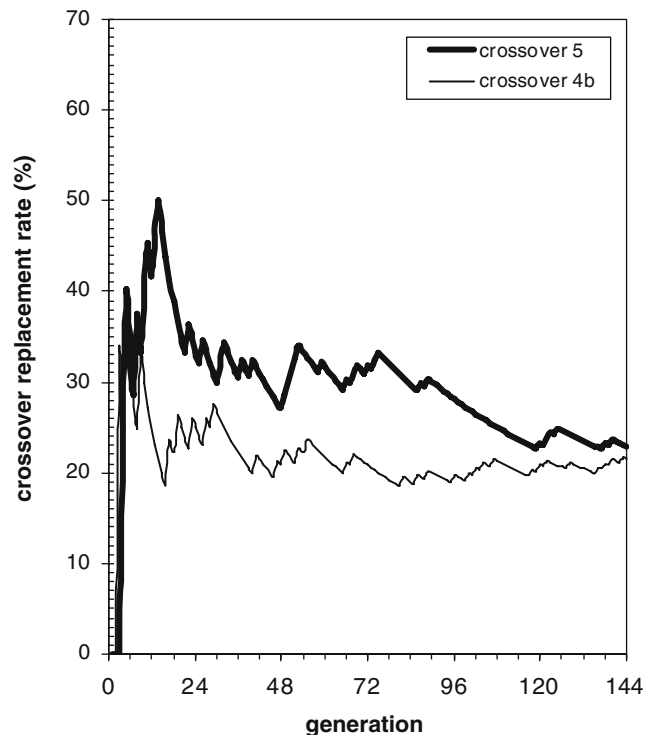

**Fig. 11** Cylindrical shell example: crossover replacement rate in elite group (%) for synergy related with crossover strategies 5 and 4b

strategy 4b has an oscillatory behaviour between 20–30%.

The reported values of Figs. 10 and 11 prove:

1. For the studied crossover strategies the crossover replacement in elite group is important exhibiting the largest rates just after the initialization of the evolutionary process;
2. Purely elitist crossover strategies 3 and 2 present higher replacement rates in elite group than mixed elitist and age-based crossover strategies 4b and 5;
3. For mixed elitist and age structured crossover strategies an improvement of synergy can be obtained by increasing the crossover replacement rate since the strong elitist crossover strategy 5 presents higher rates than weak elitist crossover strategy 4b.

### 7.2 Spherical shell problem

A second example for synergy analysis was implemented and tested using a framework made up of a spherical shallow shell reinforced with beams, illustrated in Fig. 12. The shell is hinged at its perimeter and subjected to a central point load  $F_{\max}/4 = 50$  kN; only a quarter of the structure was considered for the numerical analysis. Three shell laminates (1 to 3) and

**Fig. 12** Geometry and laminates of the spherical shallow shell structure reinforced with beams

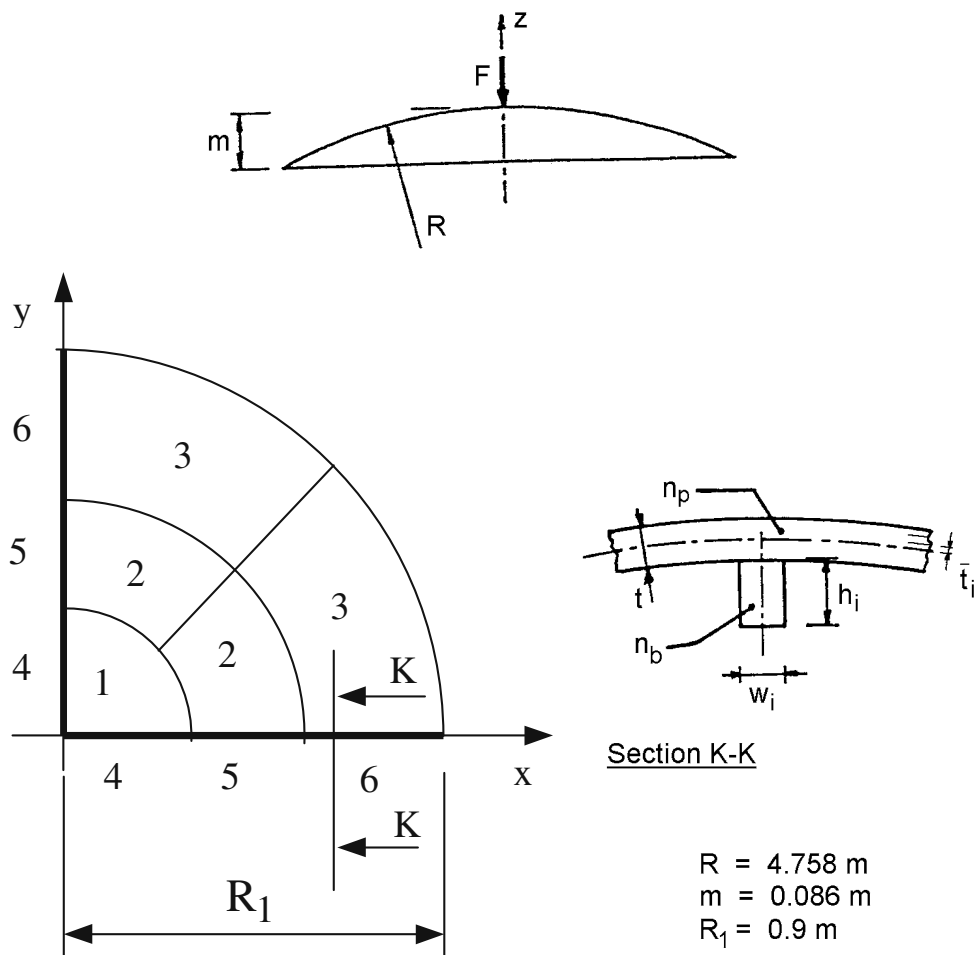

three beam laminates (4 to 6) were considered, as defined on the left side of Fig. 12.

The problem full description presented in Section 7.1.1 remains valid here. Exceptions are the prescribed maximum displacement that will be  $\bar{d}_a = 9.0 \times 10^{-2}$  m, and the constants in (17) that are  $\beta_1 = 100$  and  $\beta_2 = 1$ . Since weight and energy assume different values for this problem, the  $\beta_1$  constants take new values. Size constraints on design variables in (19) are imposed in the optimisation problem.

The mechanical properties used in hybrid composite laminate construction are presented in Table 3 and the pair material/stacking sequence defined by variable  $\pi_j$  is a combination of at least two different materials at shell laminate level. The composite laminates are symmetric and have six plies each. The beam laminates are made of material number 2 from Table 3 and it does not change along the optimisation procedure. The objective is to maximize the fitness function defined in (17) and (18). The genetic parameters described at the end of Section 7.1.1 are considered in the hierarchical genetic algorithm solving this optimisation problem.

For the synergy analysis the definitions of Section 7.1.2 are adopted. It is intended to confirm the synergy revealed in the previous example. Then, according to Table 2 the following strategies applied to spherical shallow shell are analyzed:

- Crossover strategy 3 resulting from combination of crossover strategies 1 and 2;
- Crossover strategy 4b resulting from combination of crossover strategy 2 and the non-elitist crossover ApUC\*.

Figure 13 presents the synergy obtained using crossover strategy 3. It can be concluded that the alternate use of elitist parameterised uniform crossover (EpUC) and elitist hybrid crossover with genetic improvement (EHCgi) in crossover strategy 3 clearly produces a synergy over the results obtained from the isolated use of EpUC in crossover strategy 1 and EHCgi in crossover strategy 2.

Crossover strategy 4b ( $\alpha = 0.95$ ) and crossover strategy 2 presented in Table 2 are considered in the next comparison analysis. It should be reminded



**Fig. 13** Spherical shallow shell example: synergy obtained using crossover strategy 3 resulting from crossover strategies 1 and 2

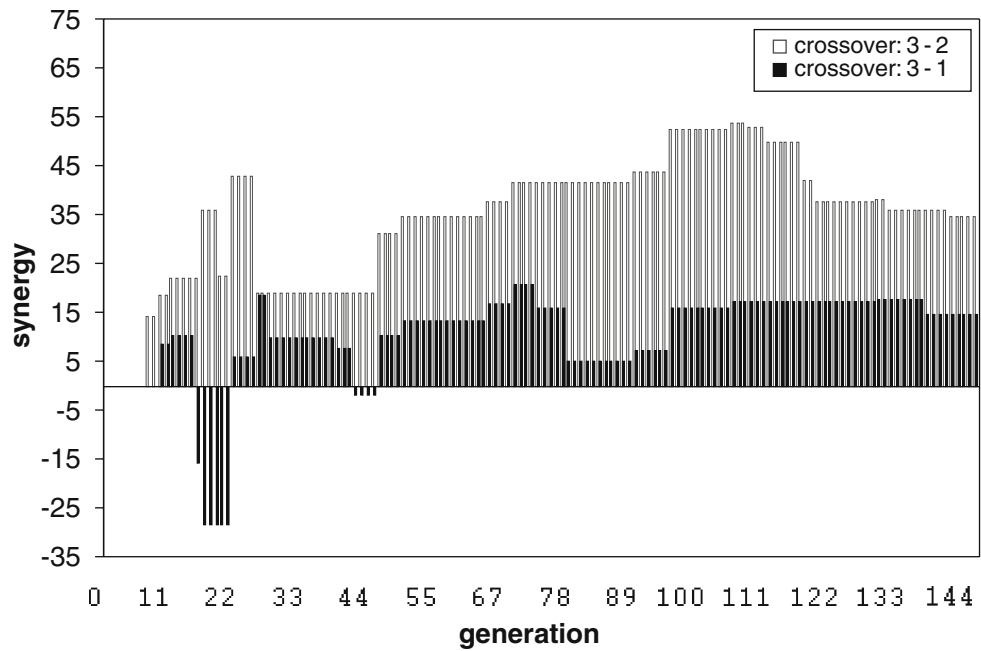

that crossover strategy 4b results from the mixed use of crossover strategy 2 and age parameterised uniform crossover (ApUC) at HGA sub-populations. It must be noticed that strategy 2 is purely elitist and ApUC is non-elitist. A fair exploitation capacity is expected for ApUC when compared with the elitists EpUC and EHCgi, both of them used in crossover strategy 2.

The comparison of two different crossover strategies—4b and 2—shows the synergy obtained when a crossover with fair exploitation capacity as ApUC is coupled with to an elitist crossover strategy. The

result is a crossover strategy with higher performance as shown in Fig. 14. This confirms the previously made analysis for the cylindrical shell example. Furthermore it is evident that it is possible to obtain synergy without using purely elitist strategies. The combined and simultaneous use of an elitist strategy and the species conservation paradigm is possible though their apparent contradictory evolutionary concepts.

The results obtained with this shallow shell example corroborate the previous study of synergy and reinforce the idea that multiple crossover operators can be

**Fig. 14** Spherical shallow shell example: synergy obtained using crossover strategy 4b ( $\alpha = 0.95$ ) when compared to crossover strategy 2

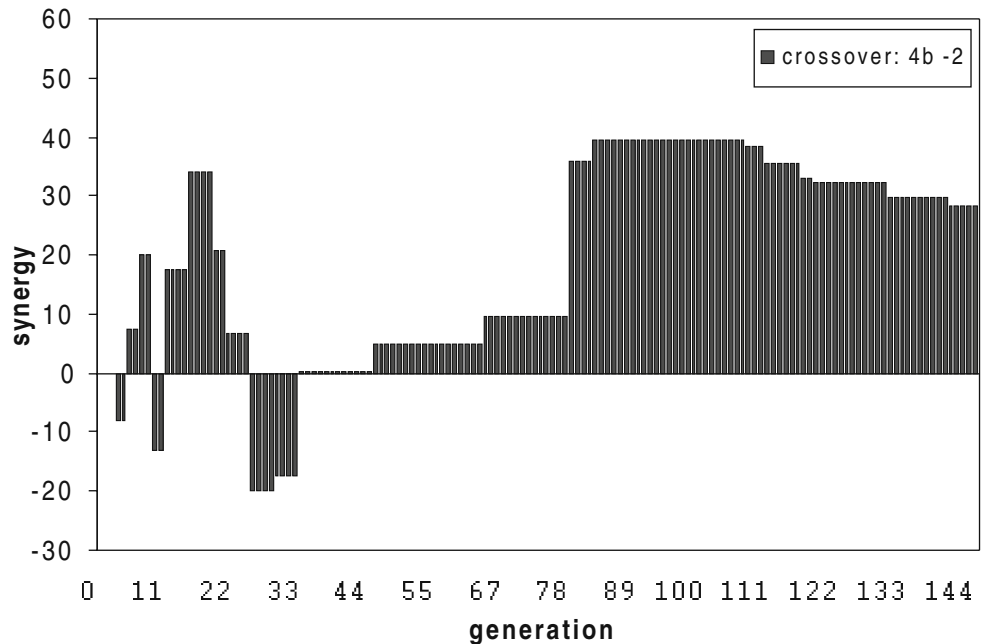

explored to obtain the effectiveness of crossover operator in GAs.

## 8 Conclusions

This paper shows that efficient combination of multiple crossover operators in structural optimization can produce important synergy effects improving the performance of Genetic Algorithms. In particular this concept is explored through the Hierarchical Genetic Algorithm (HGA) that results from application of the combination of hybrid crossover operators and heterogeneous distributed GAs.

In order to study the synergy effects six crossover strategies are considered. These strategies were built using several combinations of the following crossover operators: elitist hybrid crossover with genetic improvement (EHCgi), elitist parameterised uniform crossover (EpUC) and age parameterised uniform crossover (ApUC). The use of multiple crossovers is implemented and tested at both sub-population level and hierarchical topology level. Considering two examples of structural optimisation different styles of exploitation and exploration of the design space of the crossover strategies show different synergy effects as follows:

- Synergy effects are higher when pure elitist crossover strategies are considered;
- Crossover strategies based on mixed elitism and age-structured populations show synergy towards the end of the evolutionary processes;
- Synergies depend on the ability to build an appropriate strategy based on the use of multiple crossovers;
- High values of crossover replacement rate in elite group are important to obtain considerable synergy effects;
- It is possible to obtain good synergy effects without using purely elitist strategies.

From the numerical examples and discussion it can be concluded that synergy is revealed when multiple crossover operators are used. This is important for the user/designer that can leverage the existing synergy searching substantial improvements in GA usage. So, in order to interpret the meaning of synergy and when and how it might be obtained some guidelines can be established as follows:

- The modularity of HGA facilitates the combination of hybrid crossover operators and heterogeneous distributed GAs with benefits for the relationship

between exploration and exploitation inducing important synergetic effects.

- Hybridization is recommended as a promising strategy to improve the effectiveness of crossover operators.
- It is possible to reach synergy by using crossover operators from different taxonomy groups. The herein described combination of neighbourhood-based crossover operator (NBCO) together with discrete crossover operators (DCO) enhances this feature.
- The joint application of apparently contradictory evolutionary concepts such as pure elitism and species conservation paradigm is possible. The combination of elitist strategies together with age parameterised uniform crossover (ApUC) shows synergetic improvements. However, some ability is required so that complementarities between exploration and exploitation of space design search can be achieved.

Concluding, the use of multiple crossover operators and their hybridization is promising and necessary to obtain important synergies. Future research areas concern the study of the synergy of multiple crossover operators on problems with a design space of varied multimodalities.

## References

- Aizawa J, Hsu C, Yamada S, Fujikawa H, Shida K (1998) An effectiveness analysis of genetic operators for TSP, 6th Eur. Congr. intelligent techniques and soft computing, vol 1. Aachen, Germany, pp 465–469
- Conceição António CA (2001) A hierarchical genetic algorithm for reliability based design of geometrically non-linear composite structures. *Compos Struct* 54:37–47
- Conceição António CA (2002) A multilevel genetic algorithm for optimization of geometrically non-linear stiffened composite structures. *Struct Multidiscipl Optim* 24:372–386
- Conceição António CA (2006) A hierarchical genetic algorithm with age structure for multimodal optimal design of hybrid composites. *Struct Multidiscipl Optim* 31:280–294
- Conceição António CA, Lhate IA (2003) A hybrid crossover operator for structural optimization based on commonality in genetic search. *Engineering Computations, International Journal for Computer-Aided Engineering and Software* 20:390–408
- Deb K, Anand A, Joshi D (2002) A computationally efficient evolutionary algorithm for real-parameter evolution. *Evol Comput J* 10:371–395
- Eiben AE, Sprinkhuizen-Kuyper IG, Thijssen BA (1998) Competing crossovers in an adaptive GA framework. *IEEE conf. evolutionary computation*. Anchorage, AK, USA, pp 787–792
- Eshelman LJ, Caruana A, Schaffer JD (1989) Biases in the crossover landscape. In: Schaffer JD (ed) *Proceedings of the*

- third international conference on genetic algorithms. Morgan Kaufmann, San Mateo, CA, pp 86–91
- Herrera F, Lozano M (2000) Gradual distributed real-coded genetic algorithms. *IEEE Trans Evol Comput* 4:43–63
- Herrera F, Lozano M, Verdegay JL (1998) Tackling real-coded genetic algorithms: operators and tools for behavioural analysis. *Artif Intell Rev* 12:265–319
- Herrera F, Lozano M, Sánchez AM (2003) A taxonomy for the crossover operator for real-coded genetic algorithms. *Int J Intell Syst* 18:309–338
- Holland J (1975) *Adaptation in natural and artificial system*. The University of Michigan Press, Ann Arbor, MI
- Hong I, Kahng AB, Moon BR (1995) Exploiting synergies of multiple crossovers: initial studies. *IEEE conf. evolutionary computation*. Perth, Australia, pp 245–250
- Kita H, Kobayashi S (1999) Multi-parental extension of the unimodal normal distribution crossover for real-coded genetic algorithms. *International conference on evolutionary computation'99*. IEEE, Piscataway, NJ, pp 646–651
- Michallewicz Z, Nazhiyath GG, Michallewicz M (1996) A note on usefulness of geometrical crossover for numerical optimisation problems. *Fifth annual conference on evolutionary programming*. MIT, Cambridge, pp 305–312
- Murata T, Ishibuchi H (1996) Positive and negative combination effects of crossover and mutation operators in sequencing problems. *IEEE conf. evolutionary computation*. Nagoya, Japan, pp 170–175
- Spears WM (1995) Adapting crossover in evolutionary algorithms. In: McDonnell JR, Reynolds RG, Fogel DB (eds) *Proceedings of 4th annual conference on evolutionary programming*. MIT Press, Cambridge, MA, USA, pp 367–384
- Spears WM, DeJong SK (1991) On the virtues of parameterized uniform crossover. In: Belew RK, Booker LB (eds) *Proceedings of the fourth international conference on genetic algorithms*. Morgan Kaufmann, San Mateo, CA, pp 230–236
- Syswerda G (1989) Uniform crossover in genetic algorithms. In: Schaffer JD (ed) *Proceedings of the third international conference on genetic algorithms*. Morgan Kaufmann, San Mateo, CA, pp 2–9
- Tsutsui S, Yamamura M, Higuchi T (1999) Multi-parent recombination with simplex crossover in real-coded genetic algorithms. *GECCO-99 Genetic and Evolutionary Computation Conference*. Morgan Kaufmann, San Mateo, CA, pp 657–664
- Tuson AL, Ross P (1998) Adapting operator settings in genetic algorithms. *Evol Comput* 6:161–184
- Voigt HM, Mühlenbein H, Cvetkovic D (1995) Fuzzy recombination for the breeder genetic algorithm. In: Eshelman L (ed) *Proceedings of the sixth international conference on genetic algorithms*. Morgan Kaufmann, San Mateo, CA, pp 104–111
- Wolpert DH, Macready WG (1997) No free lunch theorems for optimisation. *IEEE Trans Evol Comput* 1:67–82
- Wright A (1991) Genetic algorithms for real parameter optimization. In Rawlin GEF (ed) *Foundations of genetic algorithms 1*. Morgan Kaufmann, San Mateo, CA, USA, pp 205–218
- Yoon H-S, Moon B-R (2002) An empirical study on the synergy of multiple crossover operators. *IEEE Trans Evol Comput* 6:212–223