



## An Updated Probabilistic Seismic Hazard Assessment for Romania and Comparison with the Approach and Outcomes of the SHARE Project

FLORIN PAVEL,<sup>1</sup> RADU VACAREANU,<sup>1</sup> JOHN DOUGLAS,<sup>2</sup> MIRCEA RADULIAN,<sup>3,4</sup> CARMEN CIOFLAN,<sup>3</sup> and ALEX BARBAT<sup>5</sup>

**Abstract**—The probabilistic seismic hazard analysis for Romania is revisited within the framework of the BIGSEES national research project (<http://infp.infp.ro/bigsees/default.htm>) financed by the Romanian Ministry of Education and Scientific Research in the period 2012–2016. The scope of this project is to provide a refined description of the seismic action for Romanian sites according to the requirements of Eurocode 8. To this aim, the seismicity of all the sources influencing the Romanian territory is updated based on new data acquired in recent years. The ground-motion models used in the analysis, as well as their corresponding weights, are selected based on the results from several recent papers also published within the framework of the BIGSEES project. The seismic hazard analysis for Romania performed in this study are based on the traditional Cornell-McGuire approach. Finally, the results are discussed and compared with the values obtained in the recently completed SHARE research project. The BIGSEES and SHARE results are not directly comparable since the considered soil conditions are different—actual soil classes for BIGSEES and rock for SHARE. Nevertheless, the analyses of the seismic hazard results for 200 sites in Romania reveal considerable differences between the seismic hazard levels obtained in the present study and the SHARE results and point out the need for further analyses and thorough discussions related to the two seismic hazard models, especially in the light of a possible future harmonized hazard map for Europe.

**Key words:** Seismic source, ground motion model, acceleration response spectra, soil class, exceedance probability, uncertainty.

### 1. Introduction

Seismic hazard analysis can be approached in a deterministic or a probabilistic manner, the latter being fully described in many references (e.g. CORNELL 1968; REITER 1990; KRAMER 1996; MCGUIRE 2004). Probabilistic seismic hazard analysis (PSHA) is performed for a site by considering all the ground motions occurring from earthquakes having a magnitude ranging from a lower to an upper bound and source-to-site distances within active seismic source(s), along with considering their associated variabilities and uncertainties.

PSHA has the advantage of fully integrating all the aleatory variabilities arising from seismicity and ground-motion levels expected from a future earthquake at a particular site. Epistemic uncertainties can be included through the use of a logic tree approach (e.g. KULKARNI *et al.* 1984; COPPERSMITH and YOUNGS 1986; BOMMER *et al.* 2005; BOMMER and SCHERBAUM 2008).

Several deterministic and probabilistic seismic hazard assessments for Romania in terms of horizontal peak ground acceleration and/or macroseismic intensities have been published since 1999 (e.g. LUNGU *et al.* 2006; MUSSON 2000; MÄNTYNIEMI *et al.* 2003; SOKOLOV *et al.* 2009; VACAREANU *et al.* 2014). A more complete list of these studies, over 15 at this time, can be found in VACAREANU *et al.* (2014).

The focus of the present study is to provide an updated seismic hazard model for Romania based on the traditional Cornell-McGuire (CORNELL 1968; MCGUIRE 1976) approach and explore some of its most significant results. The model was developed within the framework of the BIGSEES national research project in which the National Institute of Earth Physics and the Technical University of Civil Engineering Bucharest are the main contributors. The

<sup>1</sup> Seismic Risk Assessment Research Centre, Technical University of Civil Engineering Bucharest, Bd. Lacul Tei no. 122-124, Sector 2, 020396 Bucharest, Romania. E-mail: florin.pavel@utcb.ro

<sup>2</sup> Department of Civil and Environmental Engineering, University of Strathclyde, James Weir Building, 75 Montrose Street, Glasgow G1 1XJ, UK.

<sup>3</sup> National Institute of Earth Physics (NIEP), P.O. Box MG-2, 077125 Bucharest-Măgurele, Romania.

<sup>4</sup> Academy of Romanian Scientists, 54 Splaiul Independenței, 050094 Bucharest, Romania.

<sup>5</sup> Technical University of Catalonia UPC, Module C1, Campus Norte UPC Jordi Girona 1-3, 08034 Barcelona, Spain.

updated seismic hazard model (with respect to previous studies performed for Romania) includes a refined analysis of the seismicity of Romania and uses ground-motion models selected based on ground-motion recordings collected during both intermediate-depth Vrancea earthquakes, as well as during shallow crustal seismic events.

This study comprises two parts. In the first part, an updated seismic hazard analysis for Romania is performed using the information gathered within the BIGSEES national research project (<http://infp.infp.ro/bigsees/default.htm>). One of the most important objectives of the BIGSEES Project is to provide a refined and updated seismic hazard map altogether with the parameters that define the design response spectra necessary for a further revision of the seismic design code in Romania (code P100-1/2013 enforced since January 2014). In the second part of the article, the seismic hazard results for Romania are assessed and compared with some of the results obtained in the pan-European SHARE project (WOESSNER *et al.* 2015; WEATHERHILL and DANCIU 2014; SILVA *et al.* 2014). The results computed using the two seismic hazard models (BIGSEES and SHARE) point to the need for further analyses, discussions and clarifications, especially in the light of a possible future pan-European seismic hazard map based on SHARE results.

## 2. Seismic Sources and Earthquake Catalogues

Seismic sources are the locations where significant seismicity is generated. In principle, the configuration of a seismic source depends on the tectonic and geodynamic features that are active in the crust or upper mantle and which show associated seismicity. There are three types of seismic source within a PSHA (BASILI *et al.* 2009): (1) smoothed seismicity; (2) area source zones; and (3) fault sources. The first model is commonly used for areas characterized by so-called background seismicity. The last model is adopted when parameters related to active faults (geometry, activity rate and predominant focal mechanism) are well constrained.

Since for Romania many of the active faults are buried and covered by sedimentary layers and the seismic activity is usually spread out over multiple-

branched fault systems, we adopt the approach which employs source zones. Source zones represent areas of homogeneous seismicity in terms of activity rates and frequency-magnitude distributions. Outside the considered area sources, a background seismicity model which covers the remaining territory of Romania is applied. The background seismicity model is based on the recorded instrumental seismicity in each region of Romania.

A zoneless model based on the density distribution of the recent earthquakes was considered at some point but since there are large uncertainties in the position of the epicentres for the historical earthquakes and, in addition, the recent seismicity lacks medium and large magnitude crustal earthquakes, we decided to disregard this approach and instead focus on a more traditional areal sources approach.

The seismic sources contributing to the earthquake hazard of Romania are defined in Fig. 1: 13 sources of crustal depths and one of intermediate-depth seismicity in the Vrancea region. In Fig. 1 are also shown the 20 cities in Romania with more than 100,000 inhabitants according to the census performed in 2011. Largely, the sources are the same as defined by RADULIAN *et al.* (2000), keeping the same stress field characteristics. Their geometries have been slightly refined, however, to take into account the distribution of recent seismicity and the revision of historical earthquakes, recently carried out within the SHARE project (STUCCHI *et al.* 2013).

The stress regime (RADULIAN *et al.* 2000) is mainly of extensional type for most of the seismic sources in Romania and Bulgaria, with the exception of the Banat, Crisana-Maramures and Vrancea seismic sources (both crustal and intermediate-depth). Some more details of the stress patterns in Romania can be found in RADULIAN *et al.* (2000).

Geodynamic models for Romania first refer to the active tectonic processes concentrated at the sharp bending of the Carpathians Arc in the Vrancea region. Considered as a last stage of a subduction process, the region is characterized by an unusual strain rate per volume at subcrustal depths. The general tectonic frame is a continental collision between pre-alpine platforms and alpine orogen units: western margin of the East European Platform (Moldavian Platform), Scythian and Moesian Platforms, Eastern, Southern and Western (Apuseni Mountains) Carpathians, North

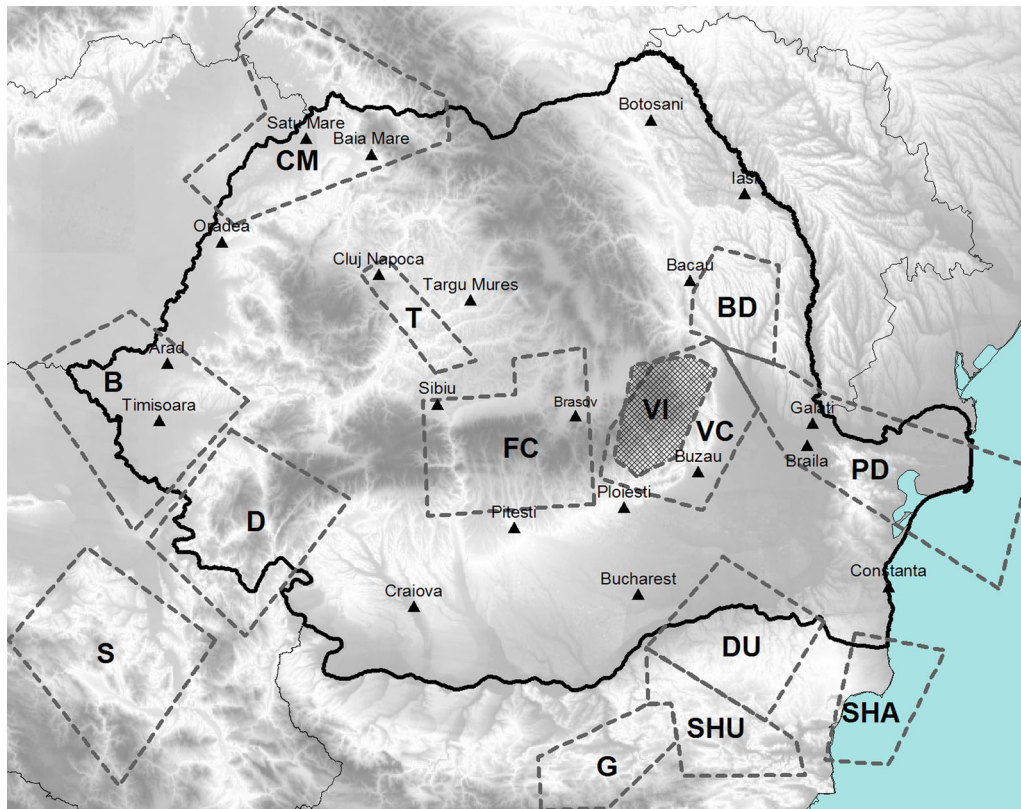

Figure 1

Sources contributing to the seismic hazard of Romania. The meanings of the acronyms on the map are: B, Banat; BD, Barlad Depression; CM, Crisana Maramures; D, Danubius; DU, Dulovo; FC, Fagaras Campulung; G, Gorna; PD, Pre-Dobrogea Depression; S, Serbia; SHA, Shabla; SHU, Shumen; T, Transylvania; VC, Vrancea crustal and VI, Vrancea intermediate-depth

Dobrogean orogeny, Transylvanian Depression and Eastern margin of the Pannonian Depression (the reader is referred to Fig. 3 of BALA *et al.* 2015). The present post-collision deformation manifests itself by rapid deformation in the mantle beneath Vrancea transferred preferentially toward the extra-Carpathians area where transcurrent and normal faulting is recorded along a system of major crustal fractures oriented SE-NW. At the same time, the platform areas are overlapped by the external units of the Carpathian Orogen, resulting in the sinking of basement and fracturing the crust along alignments parallel to the Carpathian Arc (BALA *et al.* 2015). This tectonic system explains the moderate seismicity spread in front of the Carpathians Arc bend.

Other seismicity activity is observed along the Southern Carpathians down to the Danube River. The contact between the Moesian Platform and Carpathians

orogen generates small-to-moderate crustal earthquakes as a consequence of large-scale transcurrent deformation recorded during the Tertiary drift of the tectonic units in Transylvania into the Carpathians embayment through the rapid roll-back of the slab attached to the European continent in the Vrancea region. The clockwise rotation of the upper Carpathians units with respect to Moesia is accommodated through a system of faults crossing the Danubian region in the direction NE-SW. Some enhancement of seismic activity is recorded along the contact between the Western Carpathians and the Pannonian Depression, clustered in Banat and Crişana-Maramureş zones. The back-arc region (Transylvanian Depression) has a weaker seismicity potential. The entire earthquake activity of this region is restricted to historical events, and apparently is not related to a particular geodynamic process.

The Vrancea subcrustal seismic source, located at the bend of the Carpathian Mountains in the eastern part of Romania is a region of concentrated intermediate-depth seismicity, far from any known active plate boundaries (ISMAIL-ZADEH *et al.* 2012). FROHLICH (2006) mentions that the Vrancea subcrustal nest is not particularly unusual or uncommon since the seismic activity is not so compact (the seismicity is concentrated in an area of roughly  $30 \times 70 \text{ km}^2$  and spans from 60 to 170 km in depth) and the seismic activity is not completely isolated from other seismic regions (one can notice from Fig. 1 that there are three crustal seismic sources in its vicinity). This seismic source has generated nine earthquakes having  $M_W \geq 7.0$  in the past two centuries alone. The most important Vrancea seismic events in the twentieth century occurred in October 6, 1908 ( $M_W = 7.1$ ,  $h = 125 \text{ km}$ ), November 10, 1940 ( $M_W = 7.7$ ,  $h = 150 \text{ km}$ ), March 4, 1977 ( $M_W = 7.4$ ,  $h = 94 \text{ km}$ ) and August 30, 1986 ( $M_W = 7.1$ ,  $h = 131 \text{ km}$ ). In addition, WENZEL *et al.* (1998) note that the seismic moment release of the Vrancea seismic source is of the same order of magnitude as that of Southern California.

The most important crustal seismic events that affected the territory of Romania were the two earthquakes in Bulgaria in 1901 (Shabla seismic region,  $M_w \approx 7.2$ ) and 1913 (Gorna seismic region,  $M_w \approx 7.0$ ), the Fagaras earthquake of 1916 ( $M_w \approx 6.4\text{--}6.5$ ), as well as the 1991 Banat and Danubius earthquakes (three seismic events with  $M_w \geq 5.5$ ). Recently, in November 2014, an earthquake of  $M_w = 5.6$  occurred at a focal depth of 40 km in the Vrancea crustal seismic zone. A horizontal recording obtained during this event in the epicentral region had a peak ground acceleration (PGA) of 0.26 g, which represents one of the largest PGAs ever recorded in Romania.

For Romania, we considered the ROMPLUS catalogue (ONCESCU *et al.* 1999; updated version on <http://www.infp.ro/catalog-seismic>) revised in agreement with the SHEEC catalogue produced by the SHARE Project ([www.share-eu.org](http://www.share-eu.org)). Seismic sources in the neighbouring countries with possible impact in Romania are considered, as well. The Serbian source is defined taking into account the known fault

distribution and the epicentres of events as reported in the SHARE catalogue (STUCCHI *et al.* 2013). Sources in north-eastern Bulgaria are defined following SIMEONOVA *et al.* (2006).

The positions of the earthquakes from the ROMPLUS seismic catalogue and their corresponding magnitudes are shown in Figs. 2 and 3 for the 13 crustal seismic sources and for the Vrancea subcrustal seismic source, respectively.

The ROMPLUS catalogue contains 6322 seismic events that occurred in Romania or in neighbouring countries in the period 984–2015. The histograms of magnitude, focal depth and the evolution of the number of earthquakes in the catalogue with time is given in Fig. 4. Declustering was performed using the GARDNER and KNOPOFF (1974) algorithm with the original window parameters. Special attention was given to the declustering of the catalogue for the Vrancea subcrustal seismic source, since there are many cases of doublet and even triplet earthquakes with small differences in magnitude occurring in this region (triplet earthquakes in 1893 and 1945, doublet earthquakes in 1894, 1896 and 1990).

The input parameters for each seismic source are:

- the coordinates defining the polygon of the source zone;
- magnitude of completeness  $M_C$ ;
- maximum magnitude  $M_{\max}$ ;
- activity rates and frequency-magnitude distribution; and
- hypocentral depth distribution.

Assessing the magnitude of completeness  $M_C$  for the catalogue of each source is an essential and compulsory step for seismicity analysis. The completeness magnitude  $M_C$  is theoretically defined as the lowest magnitude at which 100 % of the earthquakes in a space–time volume are detected (RYDELEK and SACHS 1989).  $M_C$  is often estimated by fitting a Gutenberg–Richter model to the observed frequency-magnitude distribution. In this study, the Maximum Curvature technique (WIEMER and WYSS 2000) is applied in order to assess the magnitude of completeness for each earthquake catalogue used in the PSHA.

The magnitude of the maximum considered earthquake,  $M_{\max}$ , is defined such that, for a given



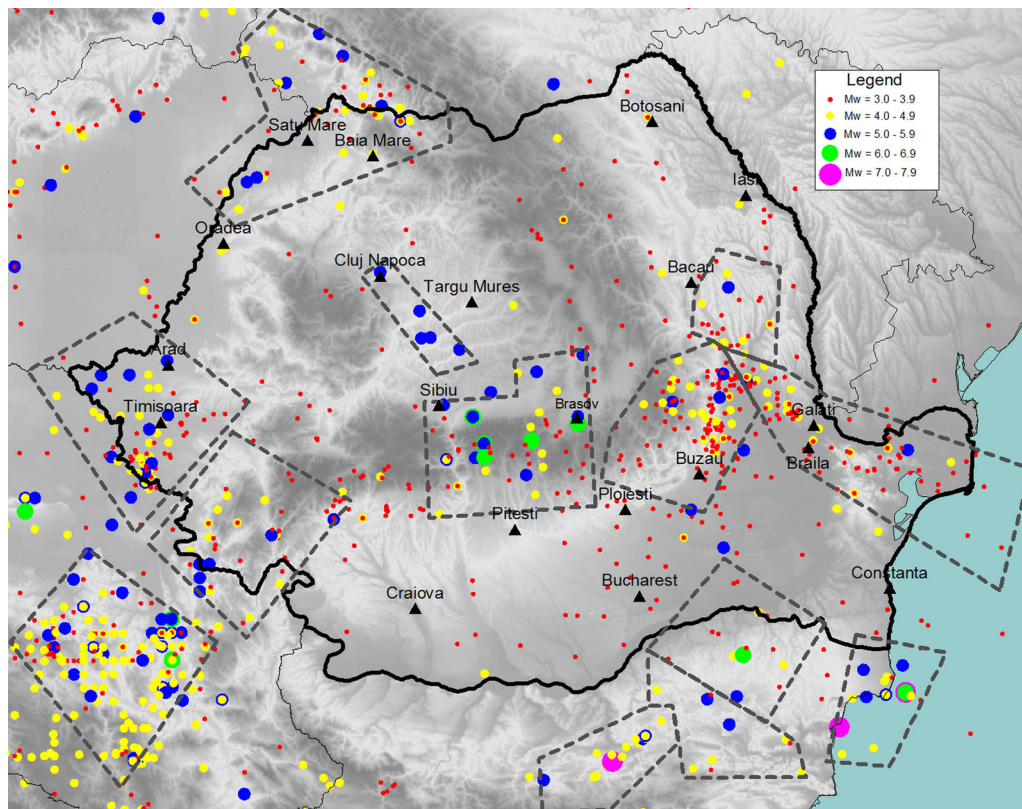

Figure 2  
Epicentres of crustal earthquakes from the ROMPLUS seismic catalogue considered in the analysis

seismic source, no earthquakes with a magnitude exceeding  $M_{\max}$  are possible. A procedure for the evaluation of  $M_{\max}$ , which is free from subjective assumptions and which is dependent only on seismic data, is given by KIJKO (2004); this approach is applied in this study. Similar to other studies (EPRI 2006; WOESSNER *et al.* 2015) a threshold magnitude is chosen ( $M_{\min} = 4.5$ ) because lower magnitude events contribute marginally to the level of seismic hazard.

Three focal depths (10, 15 and 20 km with equal weights) were considered for the majority of the crustal seismic sources, while in the case of the Vrancea crustal, Dulovo and Fagaras seismic sources deeper seismicity was also taken into account.

In the case of the Vrancea subcrustal seismic source a four-layered seismicity model was chosen based on the seismicity of the twentieth century; this model takes into account the concentration of seismic activity in the depth range 90–150 km. The depth ranges for the

four layers are: 60–90 km, 90–120 km, 120–150 km and 150–180 km. Only seven earthquakes (all with  $M_W \leq 4.1$ ) with focal depths larger than 180 km appear in the ROMPLUS catalogue and as such the seismic activity below 180 km was not considered in the analysis. The Vrancea subcrustal source has quite limited horizontal dimensions and is well-defined and hence considering a horizontal spatial variation of seismicity within each layer is not important for the computation of seismic hazard over the entire country.

The number of earthquakes (earthquakes with magnitudes larger than  $M_C$ ) in each seismic catalogue is given in Table 1. The  $a$  and  $b$  parameters of the Gutenberg–Richter relations are obtained for all the seismic sources through a maximum-likelihood method (MCGUIRE 2004). The magnitude of completeness (or the minimum considered magnitude)  $M_{\min}$ , the maximum magnitude  $M_{\max}$ , the  $b$  parameters and its corresponding standard deviation, as well

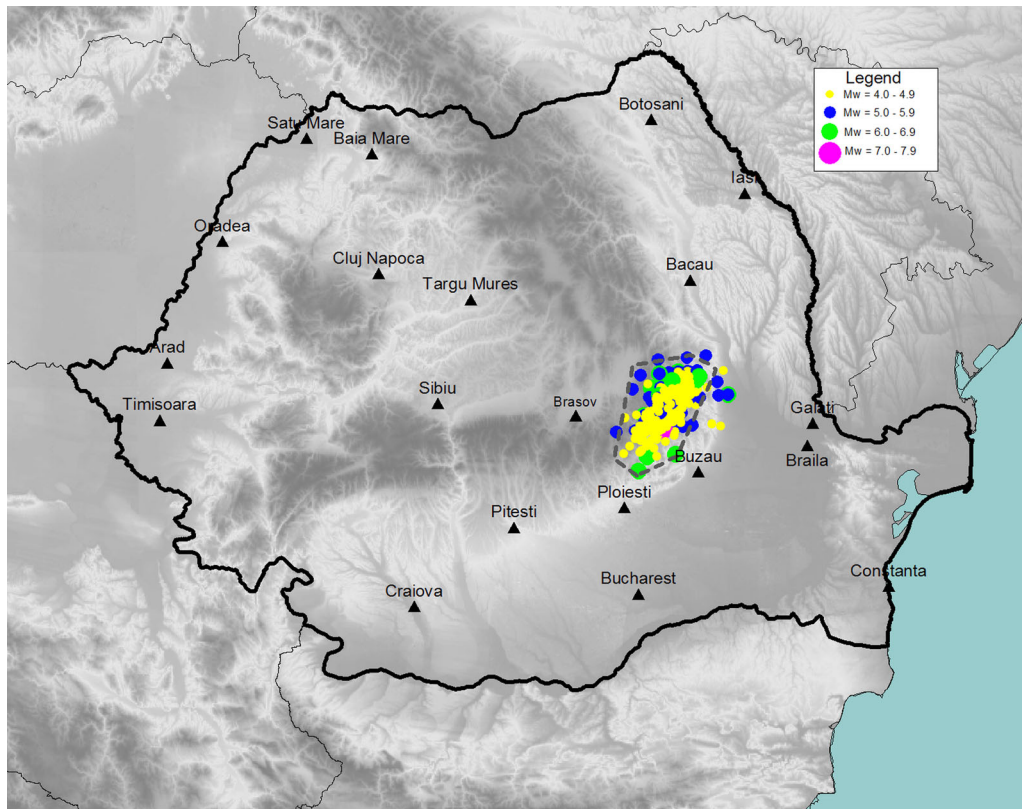

Figure 3

Epicentres of intermediate-depth earthquakes considered in the analysis from the Vrancea subcrustal seismic source according to the ROMPLUS seismic catalogue

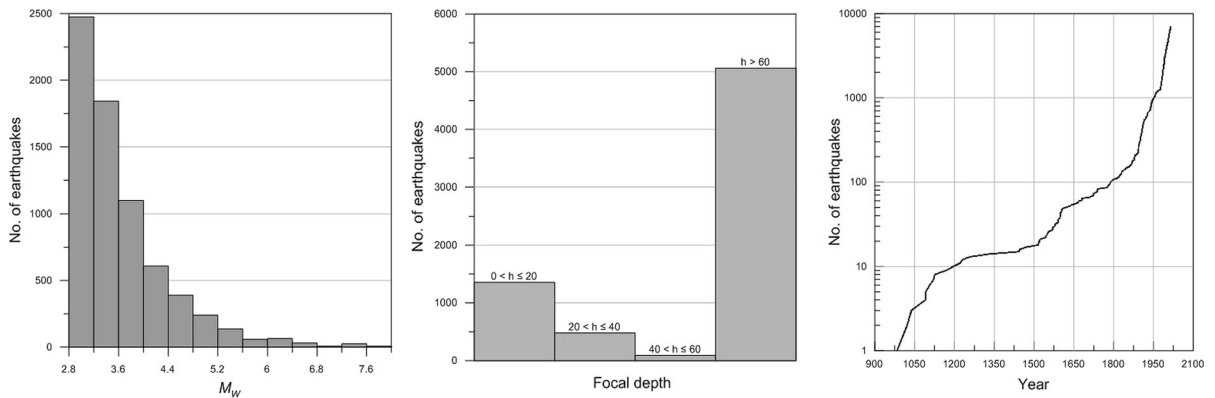

Figure 4

Histograms of magnitude, focal depth and the evolution of the total number of earthquakes with time in the ROMPLUS catalogue

as the mean annual rate of earthquakes exceeding  $M_{\min}$  (denoted as  $\lambda_{M_{\min}}$ ) are given in Table 1 for each seismic source. The comparison between the

observed seismicity and the fitted Gutenberg–Richter law is shown in Fig. 5 for all the seismic sources used in this study.

Table 1

*Seismic sources, seismicity parameters and minimum and maximum magnitudes used in PSHA, as well as the number of earthquakes within the catalogue used to assess these parameters*

Seismic source	Minimum magnitude, $M_{\min}$	Maximum magnitude, $M_{\max}$	$b$	$\lambda_{M_{\min}}$	Standard deviation of $b$	No. of earthquakes
Banat	4.5	6.4	1.10	0.17	$\pm 0.17$	57
Barlad Depression	4.5	5.8	1.07	0.07	$\pm 0.42$	40
Crisana Maramures	4.5	6.6	0.96	0.11	$\pm 0.18$	57
Danubius	4.5	6.0	0.40	0.14	$\pm 0.10$	54
Dulovo	4.5	6.6	0.49	0.09	$\pm 0.16$	21
Fagaras Campulung	4.5	6.8	0.97	0.12	$\pm 0.21$	31
Gorna	4.5	7.4	0.57	0.13	$\pm 0.20$	31
Pre-Dobrogea Depression	4.5	5.7	1.84	0.06	$\pm 0.31$	54
Serbia	4.5	6.1	1.57	0.59	$\pm 0.22$	122
Shabla	4.5	7.8	0.73	0.11	$\pm 0.20$	15
Shumen	4.5	6.3	1.48	0.07	$\pm 0.44$	16
Transylvania	4.5	6.2	0.52	0.03	$\pm 0.24$	11
Vrancea crustal	4.5	6.3	1.10	0.11	$\pm 0.11$	40
Vrancea intermediate-depth						
60–90 km	4.9	7.0	0.20	0.16	$\pm 0.20$	230
90–120 km	4.9	8.0	0.68	0.63	$\pm 0.12$	
120–150 km	4.9	8.1	0.87	1.20	$\pm 0.08$	
150–180 km	4.9	6.6	1.00	0.22	$\pm 0.18$	

### 3. Ground-Motion Models

The ground-motion models used for the PSHA were selected based on several recent studies (VACAREANU *et al.* 2013; PAVEL *et al.* 2014a, b) that dealt with the testing and grading of candidate ground motion prediction equations (GMPEs), both for the Vrancea intermediate-depth seismic source and for the crustal seismic sources.

In the afore-mentioned studies, the candidate ground-motion models were tested using the goodness-of-fit measures proposed in SCHERBAUM *et al.* (2004, 2009) and KALE and AKKAR (2013). The ground-motion database employed for the evaluation of candidate GMPEs (PAVEL *et al.* 2014b) consisted of 431 recordings from 10 intermediate-depth Vrancea earthquakes and 125 recordings from 25 crustal earthquakes. Only subcrustal seismic events with  $M_W > 5.0$  were included in the database since smaller earthquakes have relatively minor structural effects. From the observations made in Romania up to now, earthquakes with  $M_W < 5.0$  have no impact whatsoever on buildings or structures, except that they cause a certain degree of panic to the population. In addition, some of the GMPEs used in the proposed

PSHA model should strictly be applied to earthquakes with  $M_W > 5.0$ . Including smaller earthquakes in the seismic hazard assessment for Romania would have a very limited impact on the design ground motions hence their inclusion is not necessary and, because some of the GMPEs do not strictly apply below  $M_W = 5$ , extrapolation to much lower magnitudes is not justified.

All the analysed strong ground motions were collected for the BIGSEES project and were recorded mainly by three seismic networks: INCERC (Building Research Institute), INFP (National Institute of Earth Physics) and CNRRS (former National Centre for Seismic Risk Reduction, currently Research Centre for Seismic Risk Assessment). As mentioned in the previous chapter, a normal-faulting earthquake with  $M_W = 5.6$  occurred at a focal depth of 40 km in the Vrancea crustal seismic zone in November 2014. 39 pairs of horizontal recordings recorded at source-to-site distances smaller than 200 km were also added to the ground-motion database used for the evaluation of crustal GMPEs from this event. The detailed procedure for testing, as well as a description of the ground-motion database and the detailed results can be found in PAVEL *et al.* (2014b).

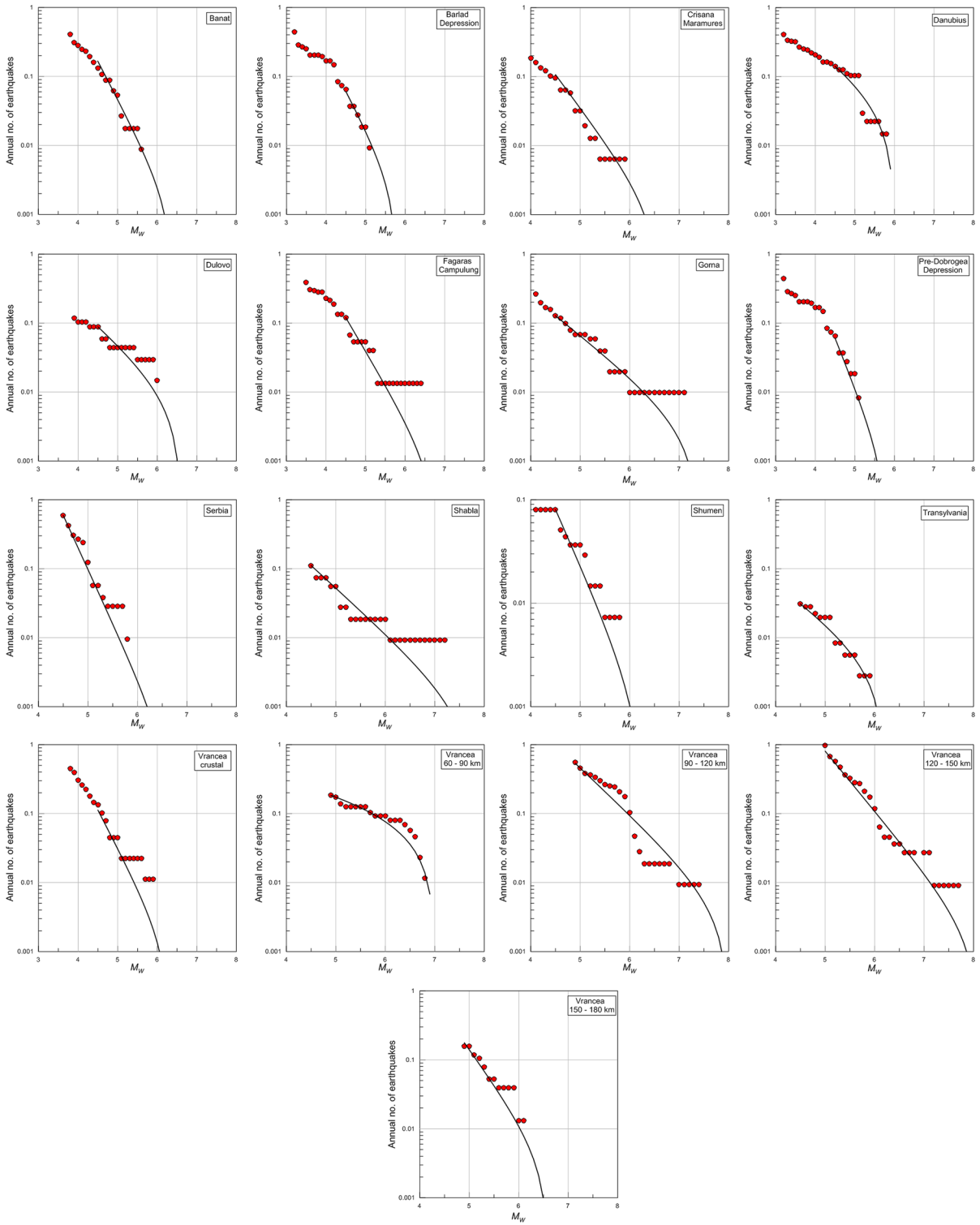

Figure 5 Comparison of observed seismicity with the fitted Gutenberg–Richter functions for all the seismic sources



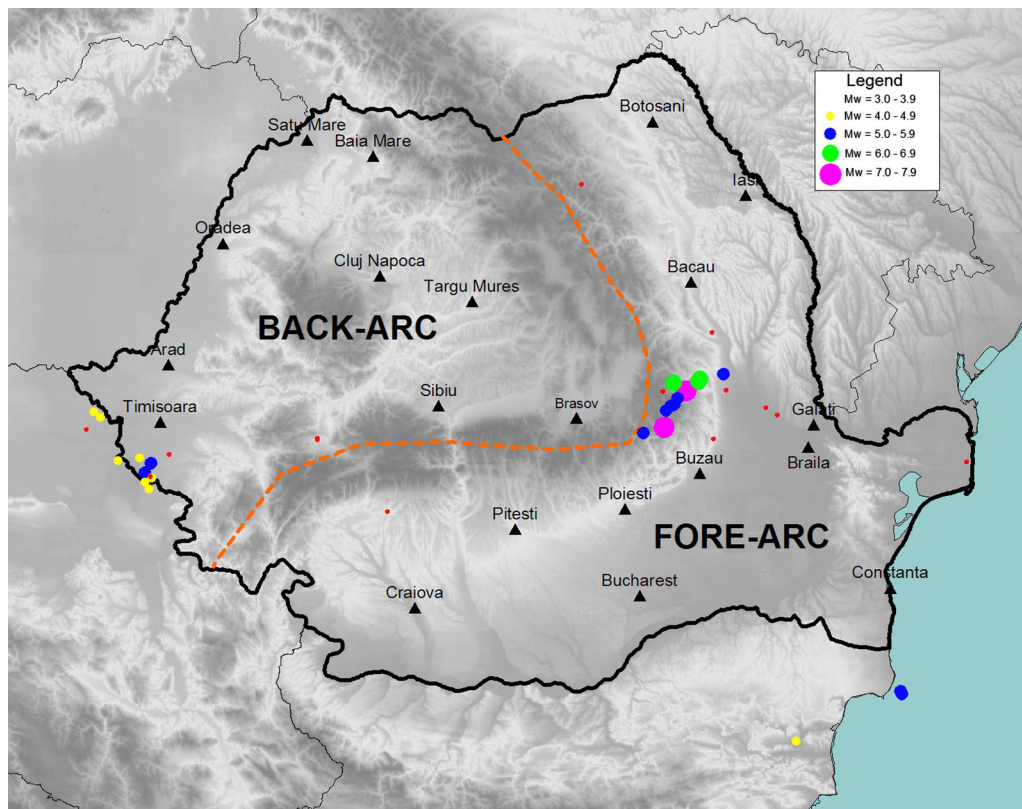

Figure 6  
Epicentres of earthquakes with available ground-motion recordings

The testing of the ground-motion models was performed separately for the fore-arc (region to the south and east of the Carpathian Mountains) and back-arc regions (region to the west of the Carpathian Mountains) defined with respect to the Vrancea subcrustal seismic source, and for the crustal seismic sources. The separation into fore-arc and back-arc regions is justified by the significant change in the attenuation of seismic waves between the two regions for the Vrancea subcrustal earthquakes (VACAREANU *et al.* 2015). The position of the earthquakes with ground-motion recordings used in the testing procedure, as well as the delineation between the fore-arc and back-arc region is shown in Fig. 6. Finally, for each of the three cases—fore- and back-arc for Vrancea subcrustal seismic source and for crustal seismic sources—based on the results of the evaluation procedure, we selected three ground-motion models. The testing procedure applied has provided us with weighing factors for each candidate GMPE.

In addition to the ground motion models graded in PAVEL *et al.* (2014b), two additional models were tested using the same ground-motion database, namely the BChydro model (ABRAHAMSON *et al.* 2015) for the Vrancea subcrustal seismic source and the AMBRASEYS *et al.* (2005) model for crustal earthquakes. The GMPEs which best fit the available ground-motion database are the following:

- Vrancea fore-arc: VACAREANU *et al.* (2015)—VEA15, BChydro model (ABRAHAMSON *et al.* 2015)—BCH15 and YOUNGS *et al.* (1997)—YEA97;
- Vrancea back-arc: VACAREANU *et al.* (2015)—VEA15, BChydro model (ABRAHAMSON *et al.* 2015)—BCH15 and ATKINSON and BOORE (2003)—AB03; and
- Crustal—CAUZZI and FACCIOLI (2008)—CF08, AMBRASEYS *et al.* (2005)—AEA05 and AKKAR and BOMMER (2010)—AB10.

Table 2  
Grading parameters for best-fitted GMPEs

Grading parameter	GMPE								
	Vrancea fore-arc			Vrancea back-arc			Crustal		
	VEA15	AEA15	YEA97	VEA15	AEA15	AB03	CF08	AEA05	AB10
<i>MEANNR</i>	0.317	0.286	−0.075	0.265	−0.251	0.005	0.378	−0.626	1.172
<i>MEDNR</i>	0.316	0.323	−0.028	0.284	−0.271	0.094	0.488	−0.527	1.253
<i>STDNR</i>	0.995	1.106	0.919	1.216	1.323	2.010	1.399	1.418	2.268
<i>MEDLH</i>	0.508	0.432	0.559	0.437	0.384	0.152	0.359	0.444	0.068
<i>EDR</i>	1.01	1.10	1.27	1.13	1.22	1.55	1.42	1.63	2.03

Table 3  
Weighing scheme employed in the PSHA for Romania

Vrancea fore-arc		Vrancea back-arc		Crustal	
GMPE	Weighting factors	GMPE	Weighting factors	GMPE	Weighting factors
VEA15	0.40	VEA15	0.40	CF08	0.40
BCH15	0.30	BCH15	0.40	AEA05	0.40
YEA97	0.30	AB03	0.20	AB10	0.20

Table 2 shows the values of several goodness-of-fit parameters proposed in SCHERBAUM *et al.* (2004, 2009) and KALE and AKKAR (2013) for the three best-fitting models. The parameters are the following: median of the likelihood *LH*—*MEDLH*, the mean (*MEANNR*), median (*MEDNR*) and standard deviation (*STDNR*) of the normalized residuals and the *EDR*, the Euclidean distance ratio (KALE and AKKAR 2013).

The final weighing scheme is given in Table 3. The weighting factors corresponding to each ground-motion model are based on the values of the goodness-of-fit parameters shown in Table 2, as well as on the distribution of the inter- and intra-event residuals (PAVEL *et al.* 2014b). The attenuation with epicentral distance of the median amplitudes of the ground-motion models used in PSHA is shown in Fig. 7.

The selected GMPEs require input parameters that are readily available for Romanian data. For the same reason, other state-of-the-art ground-motion models were not selected for analyses. Parameters like depth-to-top of rupture ( $Z_{\text{Tor}}$ ), down-dip rupture width ( $W$ ), average shear-wave velocity over the top 30 m of subsurface ( $V_{s,30}$ ) and the depth to  $V_s = 1.0$  or 2.5 km/s ( $Z_{1,0}$  and  $Z_{2,5}$ ) could not be computed

because the data needed for their estimation (KAKLAMANOS *et al.* 2011) are not available at this moment.

#### 4. Seismic-Hazard Analysis and Results

The seismic-hazard model developed in the current study and based on the Cornell-McGuire (CORNELL 1968; MCGUIRE 1976) approach will be called hereinafter the BIGSEES model. The main advantages of this model with respect to the other models previously used for PSHA for Romania (some of which are mentioned also in Chapter 1) are:

- Updated contours and catalogues for seismic sources affecting Romania territory;
- Selection of GMPEs used in the analysis is based on rigorous testing and grading procedures from the literature;
- Consideration of epistemic uncertainties through a logic tree approach; and
- Quantification of the overall uncertainties (as shown subsequently in the paper).

A logic tree (KULKARNI *et al.* 1984; COPPERSMITH and YOUNGS 1986; BOMMER *et al.* 2005; BOMMER and

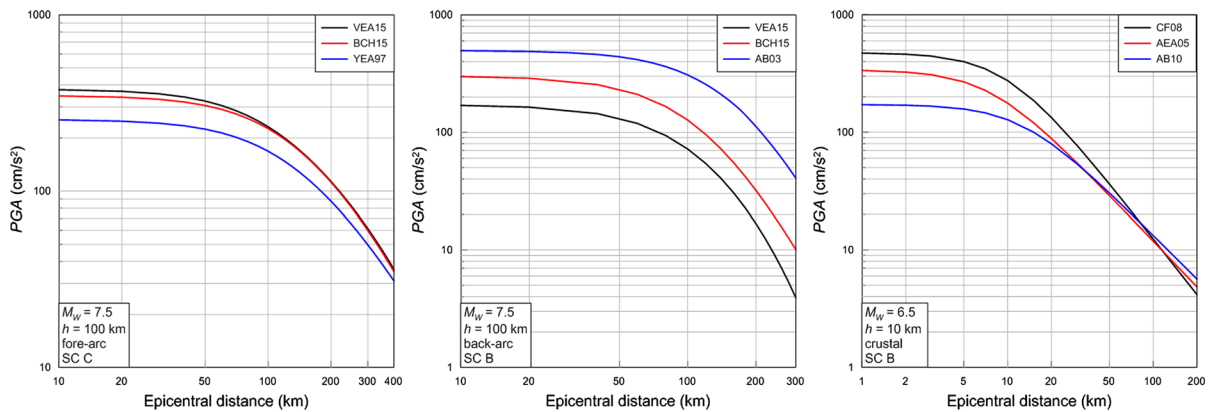

Figure 7  
Comparison of median values of GMPEs used in PSHA for Romania

SCHERBAUM 2008) is used for the computation of the seismic hazard. The branches of the logic tree represent alternative models or values of the parameters considered in the analysis. The epistemic uncertainties are expressed as branch weights representing the degree of confidence of the experts/analysts in the applicability of the models and/or parameters assigned to the corresponding branches. Finally, the PSHA results are obtained by aggregating the combined influence of the Vrancea subcrustal seismic source (either fore-arc or back-arc regions) and of the local crustal seismic sources. The logic tree used for the PSHA is shown in Fig. 8. The logic-tree contains distinct branches for the ground-motion models, source type (crustal or subcrustal) and focal depth. The  $M_{\max}$  branches from Fig. 8 are not “true” branches. Accordingly, no weight is given to the  $M_{\max}$  branch, as is the case of the focal depth or various GMPEs. The true purpose of Fig. 8 is to show in a simple manner the different maximum magnitudes assigned to the considered seismic sources, as opposed to the SHARE model which uses similar maximum magnitudes.

A uniform distribution of probability was assumed for the maximum magnitude  $M_{\max}$  corresponding to each seismic zone ( $\pm 0.3$  degrees of magnitude, similarly to the SHARE model). Moreover, uncertainty in the parameter  $b$  of the Gutenberg–Richter relation obtained through computations performed on the individual seismic catalogues is also taken into account in the analysis

through the use of the corresponding standard deviation. The computations were performed using the 2014 version of the CRISIS code (ORDAZ *et al.* 2013). In the CRISIS software,  $b$  parameter is considered as an independent random variable modelled using the gamma probability distribution. The truncation level for the standard deviation of the ground-motion models is taken as 2.5. The computations were performed on a grid of  $0.1^\circ \times 0.1^\circ$ , that covers the entire territory of Romania. The soil conditions assigned for the sites where the computations were performed were inferred from a map based on the topographic slope method proposed by WALD and ALLEN (2007). This method represents, of course, a quite rough method for the evaluation of soil conditions and it was used due to the lack of more accurate data at the national level. An evaluation of the applicability of the topographic slope method for Europe showed that it is applicable for studies covering large geographical areas (LEMOINE *et al.* 2012).

The mean seismic hazard map covering all the soil conditions for the expected geometric mean of the two horizontal components of PGA with a return period of 475 years obtained in this study is shown in Fig. 9. In Fig. 9, the high PGAs in the epicentral region of Vrancea subcrustal earthquakes are noteworthy. The reason for providing a map that covers all the soil classes present in the country is related to the seismic design code of Romania, which uses such an approach. The project that funded our research (BIGSEES project) requested such a map that could

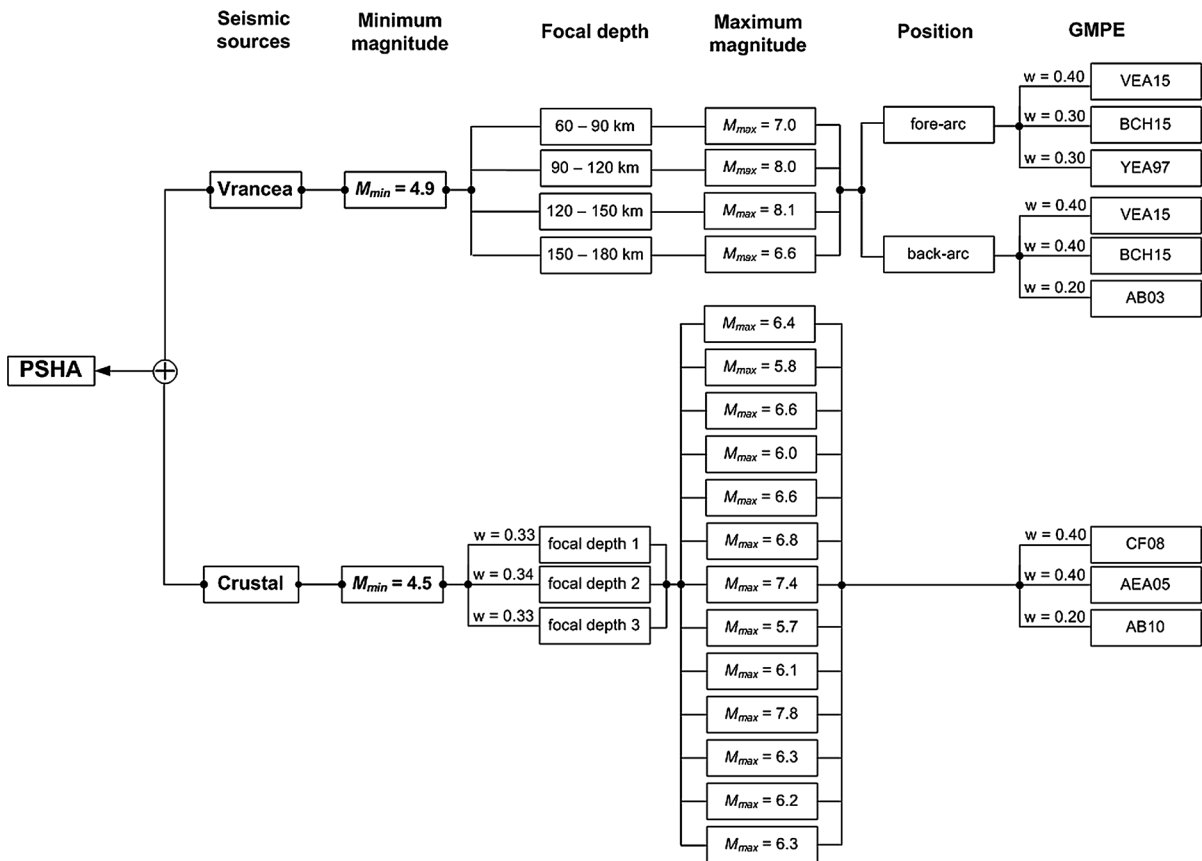

Figure 8  
Logic tree for PSHA

be used in the future for the seismic design of earthquake-resistant structures.

The mean hazard curves for the ten most populous cities in Romania according to the 2011 census are shown in Fig. 10. DOUGLAS *et al.* (2014) compare the results of different seismic hazard studies by computing the associated uncertainty levels for two spectral periods and for two mean return periods. The mean, median, 5th and 95th percentile PGAs (common to both the SHARE and BIGSEES hazard models), as well as the corresponding uncertainty levels for the 20 most populous cities in Romania (shown in Fig. 5) for a return period of 475 years are shown in Fig. 11. The uncertainty is computed with a similar relation as that proposed in DOUGLAS *et al.* (2014), namely  $100 \cdot \log(PGA_{95}/PGA_5)$ , where  $PGA_{95}$  and  $PGA_5$  are the PGAs corresponding to the 95th and 5th percentiles. The results show that the largest

differences between the mean and the median, as well as the largest uncertainties, are encountered for the cities in the western part of Romania (e.g. Arad, Cluj-Napoca, Oradea, Satu-Mare and Targu Mures), which are mainly under the influence of local crustal seismic sources. In the case of the cities situated in the eastern and southern part of Romania (e.g. Bacau, Braila, Bucharest, Buzau, Galati and Pitesti), the uncertainty is much diminished and moreover the median and mean hazard levels are closely spaced.

### 5. Evaluation of the Results and Discussion

In this section, the seismic hazard results are assessed and compared with the results obtained in the SHARE project (<http://www.efehr.org:8080/jetspeed/portal/hazard.psml>). A direct comparison of

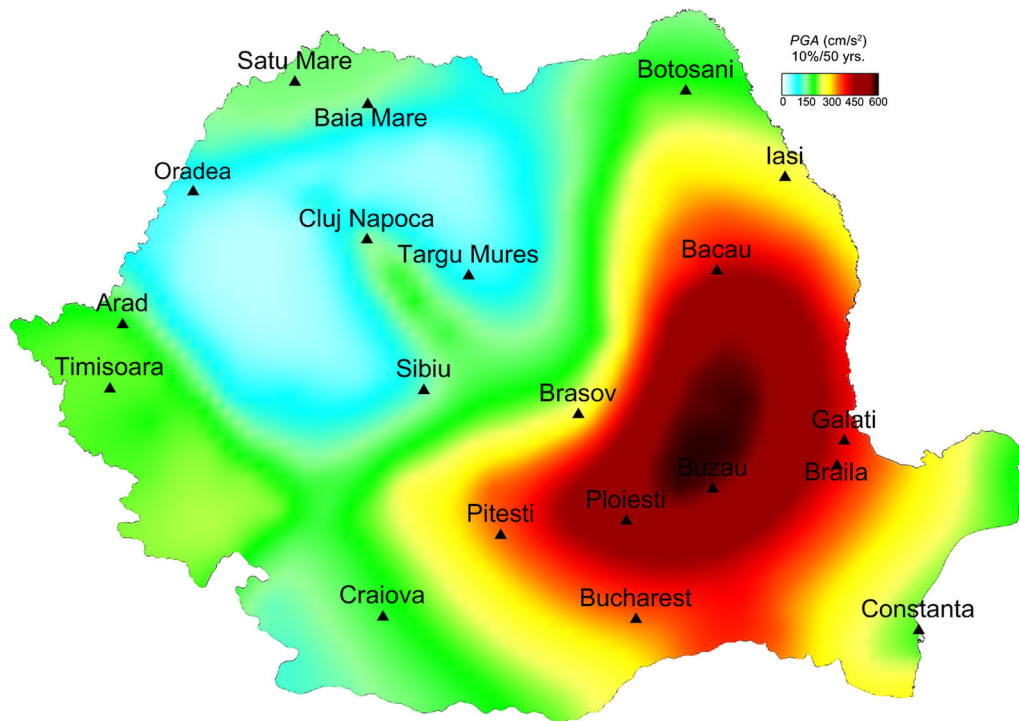

Figure 9

Seismic hazard map of Romania for the PGA corresponding to an exceedance probability of 10 % in 50 years (BIGSEES model)

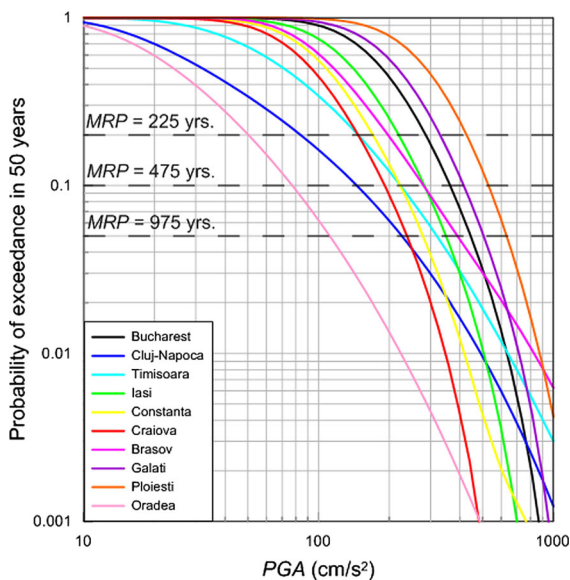

Figure 10

Mean hazard curves for PGA for the ten most populous cities in Romania

the seismic hazard results obtained in BIGSEES and SHARE research projects is not possible since the soil conditions considered are different—actual soil classes in BIGSEES and rock for SHARE. Consequently, indirect comparisons are highlighted in the subsequent section. To this end, the seismic hazard was computed for 200 sites in Romania which cover the entire territory roughly uniformly. For these sites, the slope of the seismic hazard curves ( $k$  parameter) for PGA was computed. The  $k$  parameter is obtained from the slope of the seismic hazard for return periods in the range 30–2475 years (which ensures a linear fit in log–log space), as shown in VANZI *et al.* (2015). Based on the approaches given in DOUGLAS *et al.* (2013) and VANZI *et al.* (2015), the annual probability of structural failure,  $P_{f\ st}$  is computed for the 200 selected sites. The procedure for the estimation of the annual probability of failure is based on the risk convolution integral. The structural fragility curve, whose median value corresponds to the mean



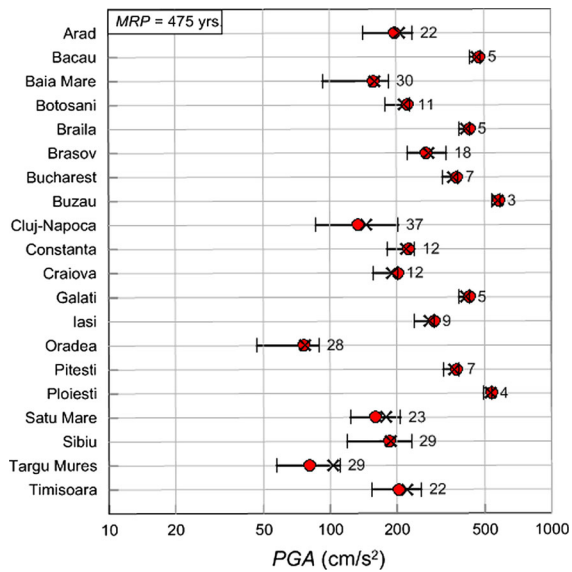

Figure 11

Comparison of peak ground acceleration values for an  $MRP = 475$  years (circles means, crosses medians; bars 5th and 95th percentiles) and the corresponding uncertainty (label), as defined in the text

PGA with a mean return period of 475 years and a lognormal standard deviation of 0.50 (DOUGLAS *et al.* 2013), is convolved with the hazard curve. The slope and the intercept of the linear fit are then used to compute the probability distribution function of the ground motion parameter (in this case, PGA). Structural failure is associated with the exceedance of the ultimate limit state as defined in Eurocode 8 (2004) (different from the collapse limit state). The results obtained with the BIGSEES seismic hazard model for the 200 sites are shown in the maps on Fig. 12 (uncertainty level,  $k$  value and corresponding mean return period of structural failure). It is noticeable from Fig. 12 that the lowest level of uncertainty and the largest values of  $k$  (corresponding to the lowest return periods of structural failure) are encountered for the sites situated in the southern and eastern part of Romania, which are under the dominant influence of the Vrancea subcrustal seismic source. The lower  $k$  values are attributed to sites in the central and western part of Romania, where local crustal seismic sources dominate.

The SHARE model for Romania (<http://www.efehr.org:8080/jetspeed/portal/hazard.psml>) is based

on area sources covering the entire territory. The truncation level used for the variability of ground motions in SHARE project is 3.0 standard deviations, while the soil conditions for all sites were taken as rock. Four ground-motion models were used for the active shallow crust sources in the SHARE project, with the largest weights given to the CAUZZI and FACCIOLI (2008) and AKKAR and BOMMER (2010) relations. In the case of the Vrancea subcrustal seismic source, two ground motion prediction equations were selected, namely YOUNGS *et al.* (1997) with a weight of 0.40 and LIN and LEE (2008) with a weight of 0.60. We are not aware of the reasons for which in the SHARE project only two of the ground-motion models proposed by DELAUDAUD *et al.* (2012) were finally selected for the Vrancea subcrustal seismic source. The ground-motion model of YOUNGS *et al.* (1997) provides the best fit to the database of ground motions from Vrancea earthquakes, as shown in several studies (e.g. VACAREANU *et al.* 2013; PAVEL *et al.* 2014a, b). Whereas, the GMPE of LIN and LEE (2008) does not fit well the available ground-motion database, as shown in the same studies, and its predicted median amplitude underestimates the observed ground motions. Moreover, this ground-motion model (for intraslab earthquakes) was developed using ground motions recorded during seismic events with magnitudes  $M_W \leq 6.6$  (intraslab earthquakes) and its applicability to larger magnitude seismic events is questionable. Another observation related to the two ground-motion models used in SHARE can be noticed from Fig. 13: the PGAs derived from the model of YOUNGS *et al.* (1997) are larger for soil than for rock conditions, while in the case of the LIN and LEE model (2008) it is exactly the opposite ( $PGA_{rock} > PGA_{soil}$ ). The computations in Fig. 13 are for an earthquake of  $M_W = 7.4$  and focal depth  $h = 94$  km, similar to the Vrancea 1977 seismic event.

The ratio of the PGAs with a mean return period of 475 years computed in this study and the results from SHARE (at the bedrock level) are shown in Fig. 14. The values for the SHARE model were obtained from the seismic hazard curves given at <http://www.efehr.org:8080/jetspeed/portal/hazard.psml>.

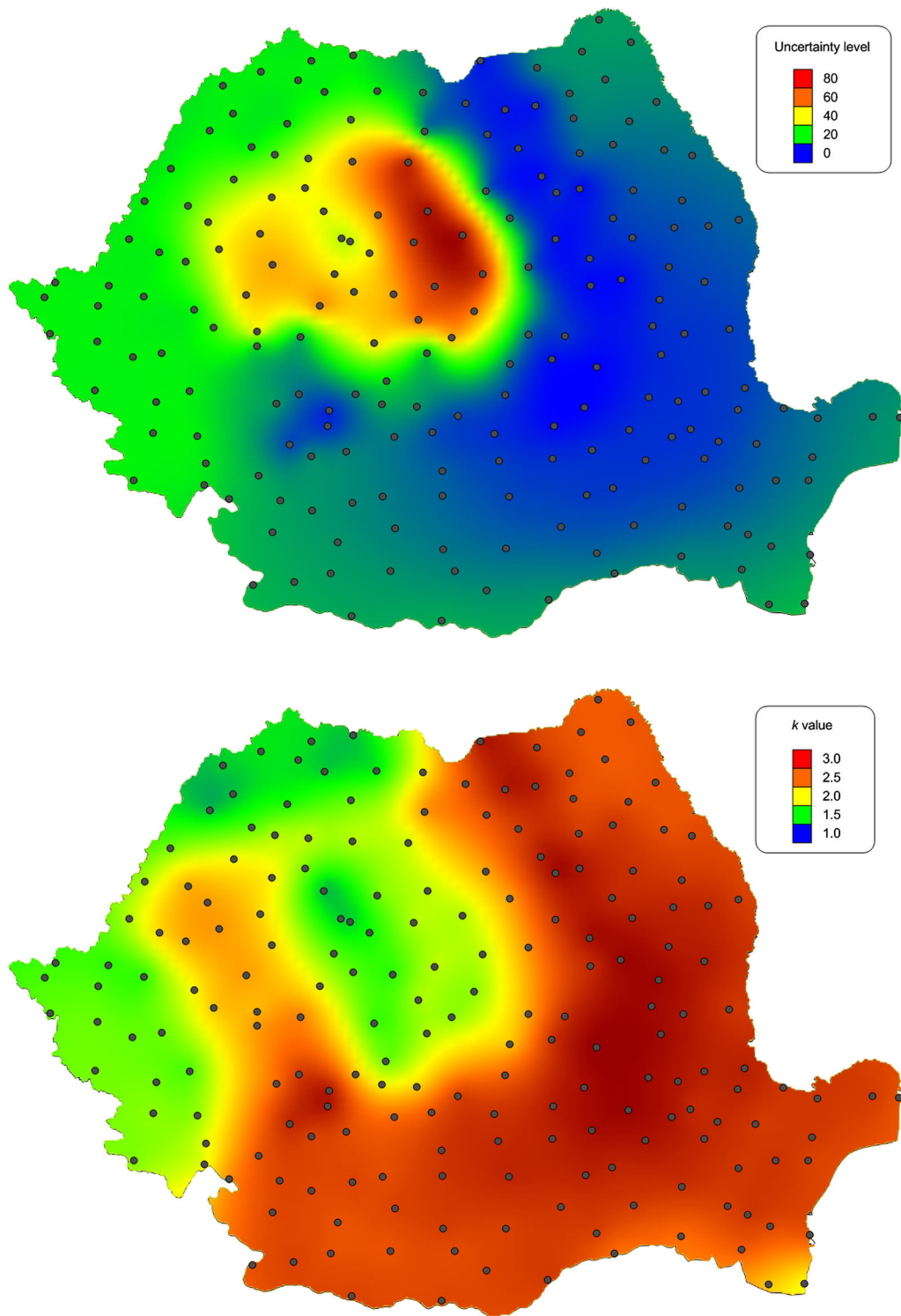

Figure 12

Maps of uncertainty,  $k$  parameter and mean return period for structural failure (exceeding of ultimate limit state) for the BIGSEES model

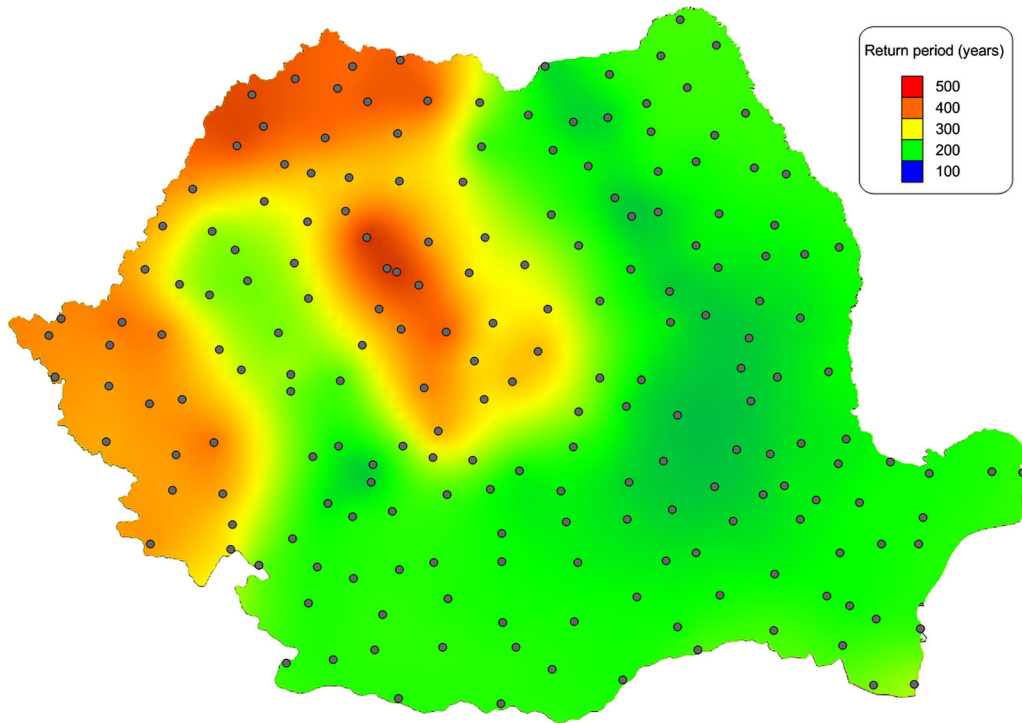

Figure 12 continued

One can notice that the differences between the PGAs from the two studies are larger than 50 % for most of the territory of Romania, especially in southern and eastern Romania, which are under the influence of the Vrancea subcrustal seismic source. Some of the difference is attributable to the different soil conditions considered in the studies (soil vs. rock). Nevertheless, the differences between PGAs with an exceedance probability of 10 % in 50 years obtained in the two hazard models are larger than the soil factors proposed in Eurocode 8 (2004) or by PITILAKIS *et al.* (2012) (albeit over 50 % of the ratios obtained fall in the domain 0.8–1.2 if one applies the soil factors proposed by PITILAKIS *et al.* 2012). Another reason for the differences encountered between the two seismic hazard models (BIGSEES and SHARE) can be attributed to the seismicity parameters of the Vrancea subcrustal seismic source. In Fig. 15, a comparison is provided between the

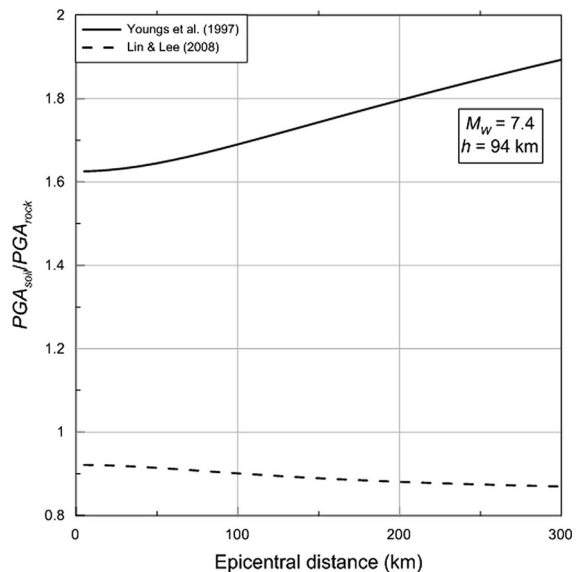

Figure 13  
 $PGA_{soil}/PGA_{rock}$  for the YOUNGS *et al.* (1997) and LIN and LEE (2008) ground-motion models

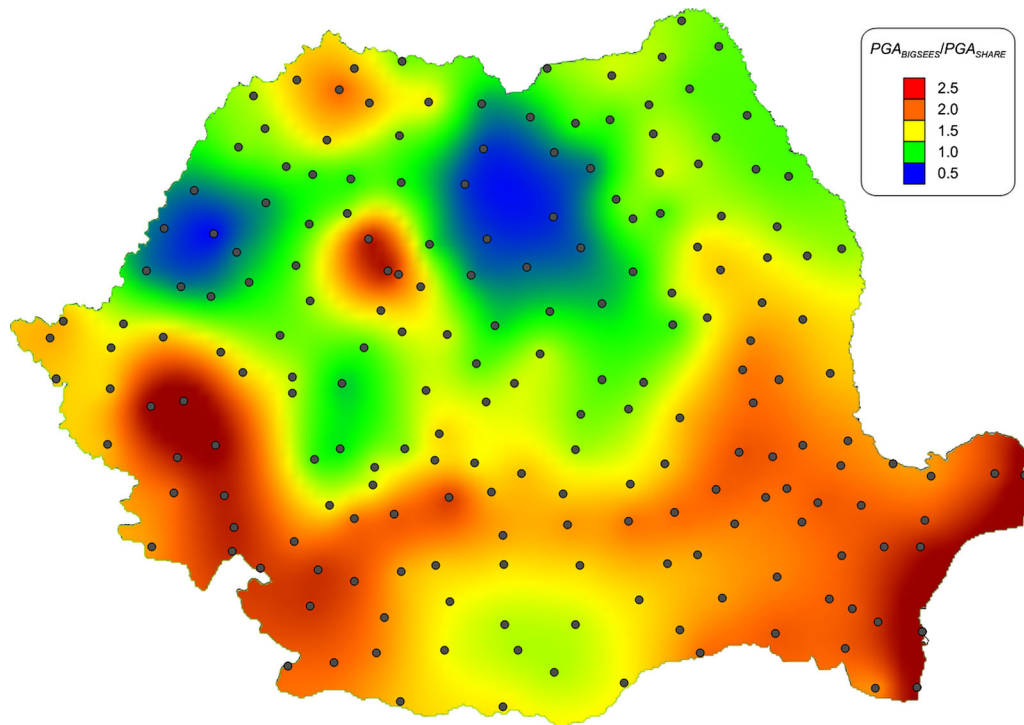

Figure 14

Ratio of PGAs for an exceedance probability of 10 % in 50 years obtained in this study (BIGSEES results on soil) and SHARE results (on rock)

fitted Gutenberg–Richter relation for the two models and the observed seismicity rates in the twentieth century. One can notice that the occurrence rates used in the SHARE model underestimates the observed seismicity. It is noted that SHARE models the Vrancea subcrustal seismic source using four regions with different maximum magnitudes and focal depths, which stretches from the Republic of Moldova to Bulgaria and covers a surface of around 50,000 km<sup>2</sup> (about one-fifth of the surface of Romania) (see Fig. 14 in WOESSNER *et al.* 2015). This seismic region, which aims to mimic an azimuthal-dependent distribution of predicted values, is over ten times larger than the actual region in which intermediate-depth seismicity has been observed and which, as shown in Sect. 2, is quite well constrained by many studies in the literature.

The relation between the  $k$  parameter (slope of the seismic hazard curve for PGA) is shown for the 200 sites in Fig. 16 for both the SHARE and the BIGSEES models. A linear trend is inferred from

both plots; however, the  $k$  values of the BIGSEES model cover a much broader range (1.3–3.0) compared to the values derived from the SHARE model, which are in the range 1.2–2.5. Nevertheless, in both cases the failure probability  $P_f$  increases almost linearly with the slope of the seismic hazard curve  $k$ . The  $k$  values obtained from both models are plotted on the same graph in Fig. 17 revealing a somewhat linear increasing trend, as revealed by the fitted trendline (although the trend is not too well constrained by data due to increased variability of the results).

An exponential relation between the parameter  $k$  and the ratio of PGAs for return periods of 475 and 225 years is inferred from Fig. 18 for both seismic hazard models (BIGSEES and SHARE). A  $k$  value of 3 is recommended in Eurocode 8 (2004) and this leads to a ratio of the PGAs for mean return periods of 475 and 225 years (mean return period in the Romanian seismic design code P100-1/2013) of around 1.25. In the case of lower  $k$  values this ratio can be as high as 1.70. Larger

$k$  values lead to lower ratios between the PGAs with exceedance probabilities of 20 and 10 % in 50 years, while for smaller  $k$  values the opposite trend holds true.

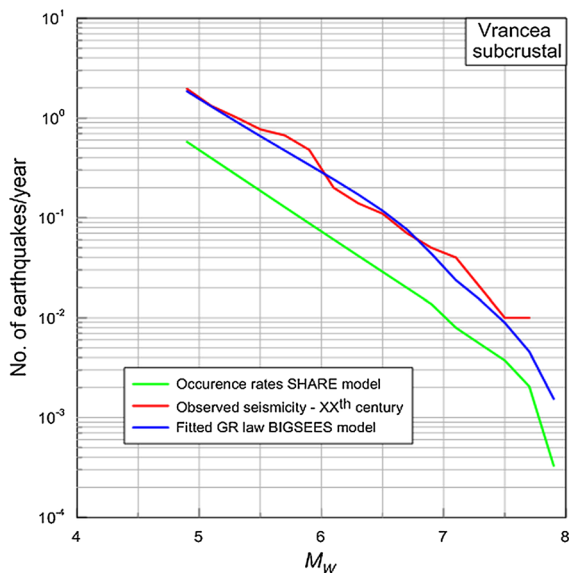

Figure 15

Comparison of the seismicity parameters adopted in the two seismic hazard models (BIGSSES and SHARE) and the observed seismicity of the twentieth century for the Vrancea subcrustal seismic source

The PGA for an annual failure probability  $P_f = 2 \times 10^{-4}$  is computed, as proposed in LUCO *et al.* (2007). The ratio of the PGA for an annual failure probability  $P_f = 2 \times 10^{-4}$  to the PGA with 10 % exceedance probability in 50 years is similar for both seismic hazard models: mean = 2.61 and standard deviation = 0.19 for the SHARE model and mean = 2.67 and standard deviation = 0.14 for the BIGSEES model.

Two recent papers, namely WEATHERHILL and DANCUI (2014) and SILVA *et al.* (2014), assess some of the results obtained in the SHARE project and further develop them to compute some of the parameters describing the design spectrum of Eurocode 8 (2004) and to derive risk-targeted maps for Europe. The results for Romania, shown in the two afore-mentioned references, are debatable for the following two related issues:

- the  $k$  values for Romania (and for PGA) are larger than 2.5, with pockets in which  $k$  reaches the maximum value anywhere in Europe ( $k = 4.5$ ) (WEATHERHILL and DANCUI 2014). These pockets of large  $k$  values do not correspond to any seismic source used in the SHARE hazard model. Even though the map of  $k$  values shown in WEATHERHILL and DANCUI (2014) resembles the map displayed in

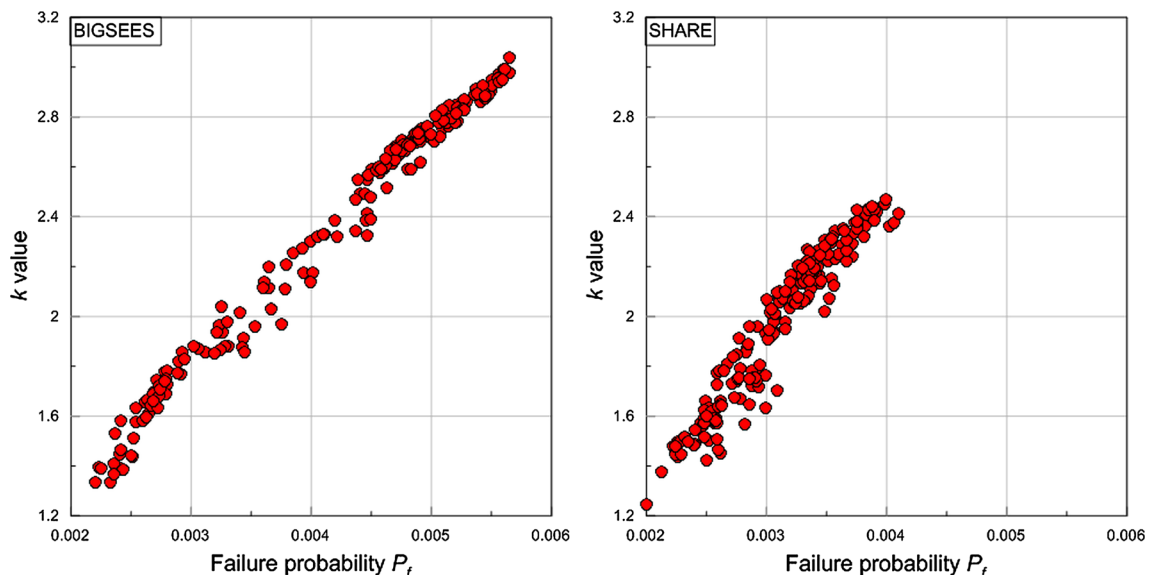

Figure 16

Slope of the seismic hazard curve ( $k$  value) against failure probability  $P_f$  for 200 sites in Romania—BIGSEES model (*left*) and SHARE model (*right*)



- Fig. 19, there are significant differences in the  $k$  values; and
- the annual collapse probability is amongst the smallest in Europe, with most of the territory of

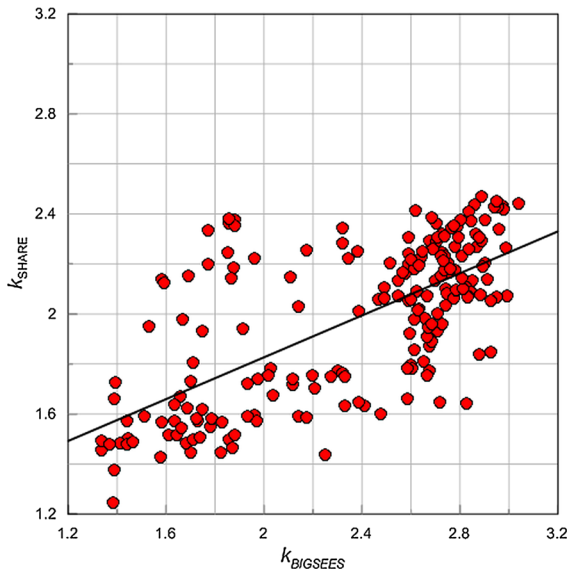

Figure 17

Relation between the  $k$  values obtained in the two seismic hazard models (BIGSEES and SHARE). The black line shows the fitted trendline

Romania having assigned an annual failure probability in the range  $10^{-5}$ – $10^{-6}$ .

Because the annual probability of failure should have a strong positive correlation on  $k$  parameter, these results are in our opinion contradictory.

Moreover, there is a need to further discuss the results obtained using the two seismic hazard models (SHARE and BIGSEES) in the light of the building provisions of the Romanian seismic design code P100-1/2013 (2013) and its previous two versions. For instance, the seismic hazard level for Bucharest has increased from a value of PGA of 0.20 g (period 1978–2006), to 0.24 g (period 2007–2013) and up to 0.30 g (present level) for mean return periods of 50, 100 and 25 years, respectively. In the case of Focsani, the seismic hazard level has increased from 0.28 to 0.40 g in the current version of the seismic code. Consequently, people unfamiliar with the field of seismic hazard might falsely consider, based on the maps given in WEATHERHILL and DANCIU (2014) and SILVA *et al.* (2014), that the provisions of all the Romanian seismic codes in the past 30–40 years have led to over-sized buildings and structural cross-sections. There is a strong need to emphasize that the

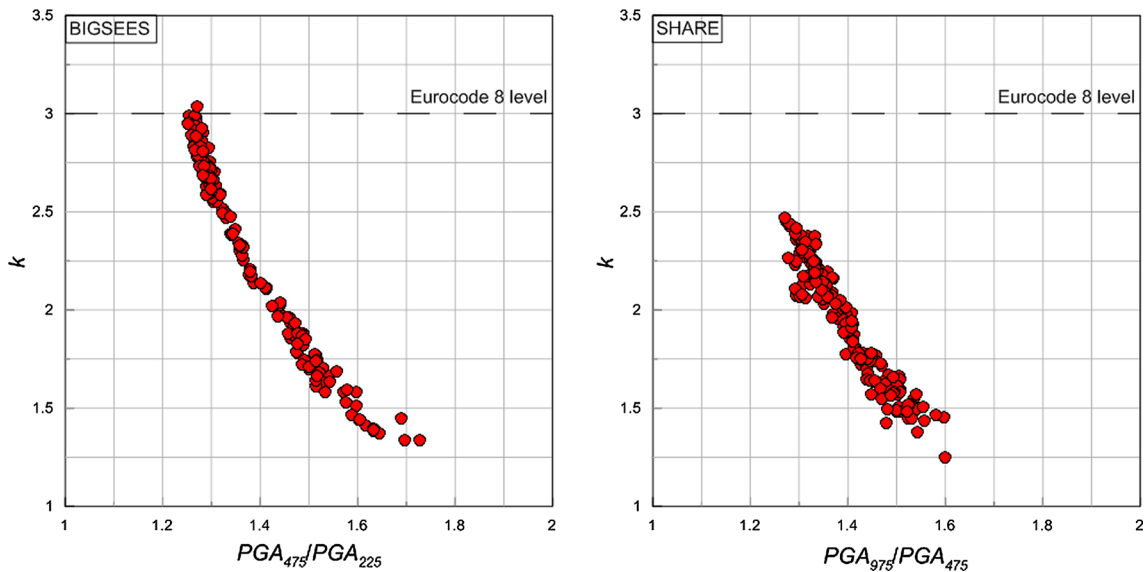

Figure 18

Relation between the  $k$  value and the ratio of the PGA with exceedance probability of 10 % in 50 years to 20 % in 50 years for the two seismic hazard models (BIGSEES and SHARE)

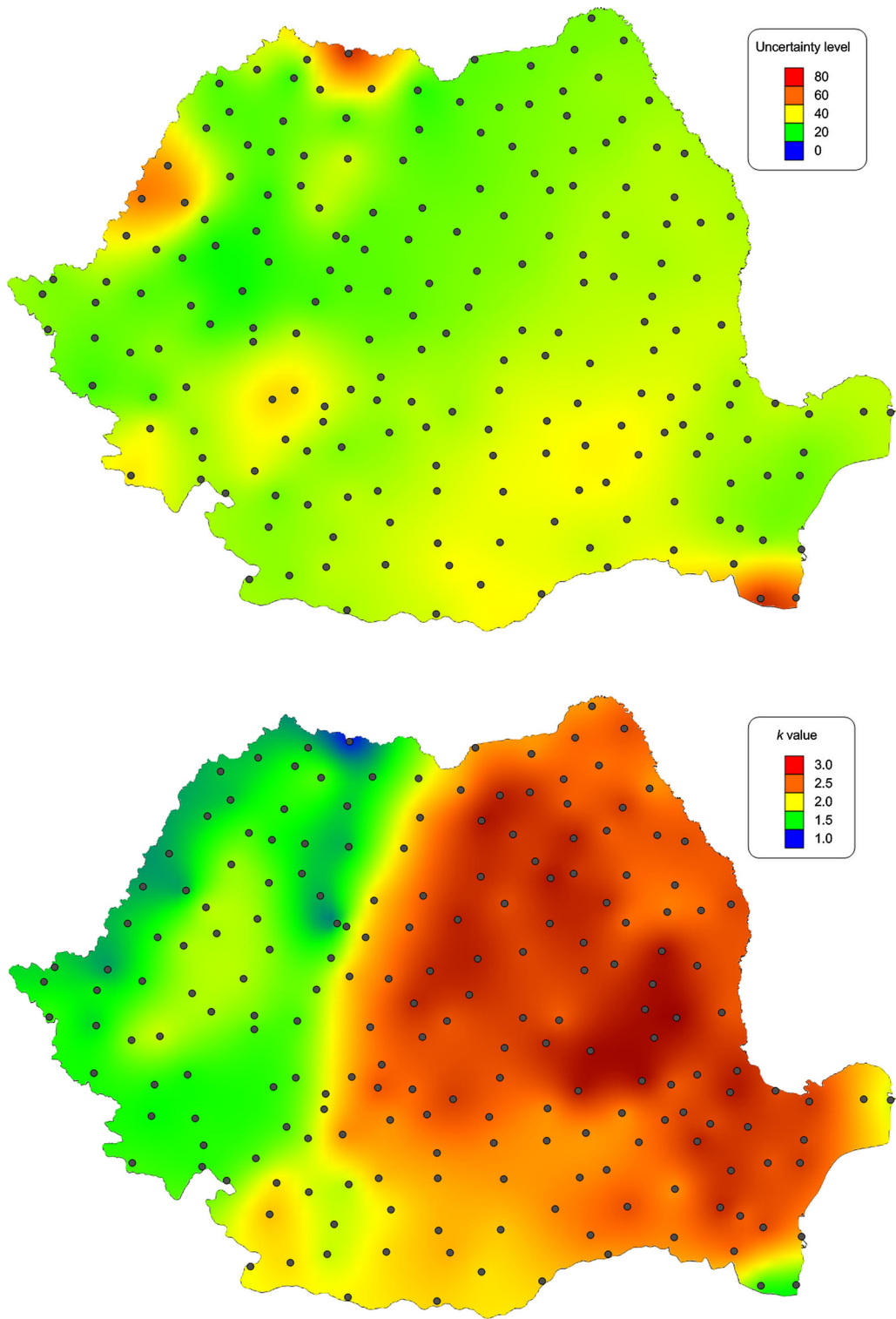

Figure 19  
Maps of uncertainty level and  $k$  parameter for the SHARE model

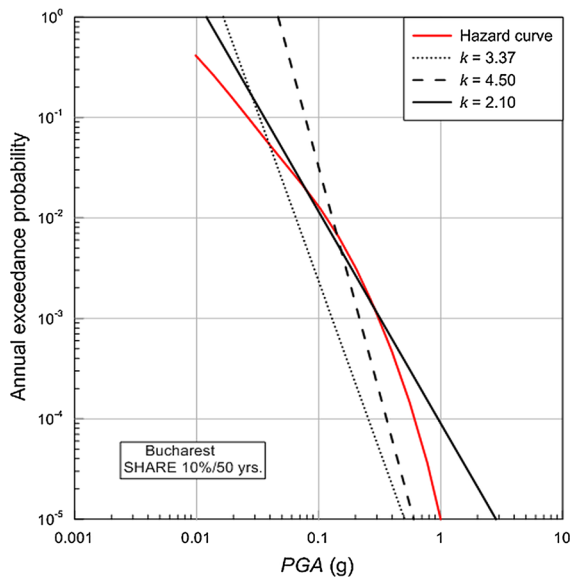

Figure 20

Comparison of seismic hazard curves for Bucharest for PGA with different  $k$  values

seismic hazard map obtained in the SHARE project is for rock conditions, which might only occur at depths of the order of several kilometres, particularly in most of the southern and eastern Romania. As such, the SHARE seismic hazard map cannot be applied without proper site-dependent soil amplification factors.

The  $k$  value and its method of computation, in particular the limits of the curve for which the integration is performed have a great impact on the computed failure probability. Figure 20 shows such an example starting from the hazard curve for Bucharest (for PGA) obtained in the SHARE project. A  $k$  of 3.37 is obtained for the interval from 0.01 to 3.45 g,  $k = 4.50$  for the interval 0.05–3.45 g, while the final  $k$  (equal to 2.10) is determined from the PGA range 0.05–0.40 g. The fitted lines have slopes that vary by a factor of two; hence, it is crucial to select the correct range in which the seismic hazard curve can be approximated by a straight line. For instance, the  $k$  value of 2.10 approximates the curve for mean return periods between 25 and 2200 years very well, which represent the domain of interest for current seismic codes. The other two  $k$  values, which are determined based on a much broader range of PGAs, do not closely match the hazard curve, especially in the region of engineering interest.

## 6. Summary and Conclusions

The analysis of the results obtained for the PGA with an exceedance probability of 10 % in 50 years, and the comparison with the results obtained in the pan-European SHARE project, highlights the following important issues:

- There are considerable differences between the results obtained using the two seismic hazard models (BIGSEES and SHARE), especially for the region in southern and eastern Romania that is under the dominant influence of the Vrancea subcrustal seismic source. This study has obtained results close to the ones computed by SOKOLOV *et al.* (2009). However, one has to consider that SOKOLOV *et al.* (2009) used only one ground motion model (namely, AMBRASEYS *et al.* 1996) for the crustal seismic source, while for the Vrancea seismic source, they use only two GMPEs (the azimuth-dependent model developed by SOKOLOV *et al.* 2008 for the Vrancea subcrustal seismic source and the model of LUNGU *et al.* 2000 which can be used only for PGA). From the point of view of the values, the PGAs with 10 % exceedance probability in 50 years obtained for Bucharest and Focsani are slightly larger in the BIGSEES model (around 10 %) as compared to the SOKOLOV *et al.* (2009) model.
- The seismicity of the sources affecting the Romanian territory is different in the two models:
  - the SHARE models includes seismic sources covering the entire territory of Romania, with similar minimum and maximum magnitudes, while the BIGSEES model uses concentrated seismic sources with similar minimum magnitudes and different maximum magnitudes. The occurrence rates are computed in a similar manner for both models, albeit in the case of the SHARE model the seismicity is distributed over a much larger area;
  - The SHARE model defines the Vrancea subcrustal seismic source as having an area of around 50,000 km<sup>2</sup> in order to model a likely azimuth-dependent pattern of ground-motion amplitudes. Thus, there are four zones of different focal depths, maximum magnitudes and seismicity

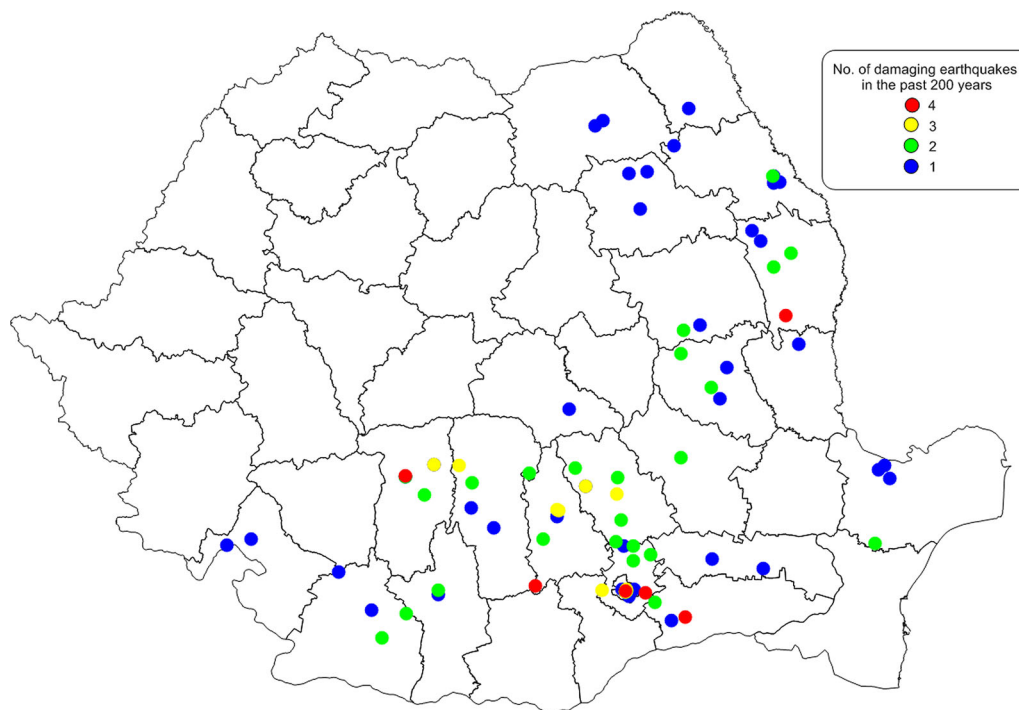

Figure 21

Map of 83 monasteries in Romania damaged by Vrancea earthquakes that occurred in the past 200 years with  $M_W \geq 7.4$  (compiled after MĂRMUREANU, 2015)

parameters that cover an area roughly ten times the zone in which intermediate-depth seismicity was observed in Vrancea. In the BIGSEES model, the Vrancea subcrustal seismic source is confined to an area of about 5000 km<sup>2</sup> and the azimuth-dependent attenuation is only related to the regions in front of the Carpathian Mountains (fore-arc region) and behind the Carpathian Mountains (back-arc region). The map in Fig. 21, which is based mainly on the work of MĂRMUREANU (2015), shows how often 83 monasteries in Romania were damaged (once or several times) during large magnitude ( $M_W \geq 7.4$ ) Vrancea earthquakes that occurred in the past 200 years (in 1802, 1838, 1940 and 1977). Four means that all the four earthquakes (in 1802, 1838, 1940 and 1977) damaged the monastery, three means that the monastery was damaged by three of the four seismic events and so on. The first interesting observation is that the monasteries damaged by earthquakes are situated in an area containing half of eastern Romania and most of

the southern part. However, if we look at the monasteries damaged once, the area is roughly equal to 60 % of the territory of Romania. We can find monasteries situated at over 300 km from the epicentral region of the Vrancea earthquakes that were damaged either in the 1802, 1838, 1940 or 1977 earthquakes. Another interesting observation is that the monasteries in the northern Dobrogea region (region adjacent to the Black Sea) were all damaged by the same Vrancea seismic event—the 1940 earthquake. Considering these observations, we find questionable the quite rapid attenuation towards Dobrogea given by the SHARE model;

- Two ground-motion models (YOUNGS *et al.* 1997; LIN and LEE 2008) were selected for the Vrancea subcrustal seismic source in the SHARE model, but recent testing using ground motions recorded during Vrancea intermediate-depth earthquakes has shown that the LIN and LEE (2008) GMPE underestimates the ground-motion amplitudes.

Moreover, one has to take into account that the LIN and LEE model (2008) was derived from ground motions recorded during earthquakes with  $M_W \leq 6.6$  (for intraslab earthquakes).

- The earthquake occurrence rates for the Vrancea subcrustal seismic source used in the SHARE model appear to underestimate the observed seismic activity for the twentieth century.
- There is a linear trend between the slope of the seismic hazard curve ( $k$  value) and the associated annual failure probability, as highlighted by the results obtained for 200 sites in Romania.
- The uncertainty associated with the seismic hazard results has different patterns for the two hazard models: in the BIGSEES model, the uncertainty is larger for sites under the influence of local crustal seismic sources and smaller for the sites under the influence of the Vrancea subcrustal seismic source, while in the SHARE model the uncertainty is more uniform across Romania.
- The limits of the seismic hazard curve between which the power function is fitted have a great impact on the associated  $k$  values and on the corresponding structural failure probability. Based on these findings we noticed that the map shown in SILVA *et al.* (2014) contains some questionable results since Romania has neither the lowest seismic hazard in Europe nor the most over- or under-sized structures.

In summary, we consider that in the light of the recent seismic hazard studies performed for Romania, more discussions and clarifications are needed to obtain a future map that reflects accurately the seismic hazard of Romania, and which can be used in a possible future pan-European seismic hazard map. Moreover, if one aims at converting a seismic hazard zonation map into a design tool for a compulsory seismic code, the map must provide a well-balanced scientifically sound target level of safety for new structures.

#### Acknowledgments

The results presented in this paper are obtained within the BIGSEES Project financed by the Romanian Ministry of Education and Scientific Research (MECS) under Grant Number 72/2012. This support

is gratefully acknowledged. Authors would like to thank Prof. M. Ordaz (Instituto de Ingenieria, UNAM, México) for providing the CRISIS 2014 software. The constructive comments from two anonymous reviewers are greatly appreciated as they have helped us to improve considerably the quality of the manuscript.

#### REFERENCES

- ABRAHAMSON, N.A., GREGOR, N., and ADDO, K. (2015), *BC Hydro ground motion prediction equations for subduction earthquakes*, Eq Spectra, doi:[10.1193/051712EQS188MR](https://doi.org/10.1193/051712EQS188MR).
- AMBRASEYS, N.N., SIMPSON, K.A., and BOMMER, J.J. (1996), *Prediction of horizontal response spectra in Europe*, Eq. Eng. Struct. Dyn., 25, 371–400.
- AMBRASEYS, N.N., DOUGLAS, J., SARMA, S.K., and SMIT, P.M. (2005), *Equations for the estimation of strong ground motions from shallow crustal earthquakes using data from Europe and the Middle East: horizontal peak ground acceleration and spectral acceleration*, Bull. Eq. Eng., 3, 1–53.
- AKKAR, S., and BOMMER, J.J. (2010), *Empirical equations for the prediction of PGA, PGV and spectral accelerations in Europe, the Mediterranean and the Middle East*, Seismol. Res. Lett., 81(2), 95–206.
- ATKINSON, G., and BOORE, D. (2003), *Empirical ground-motion relations for subduction-zone earthquakes and their application to Cascadia and other regions*, Bull. Seismol. Soc. Am., 93(4), 1703–1729.
- BALA, A., RAILEANU, V., DINU, C., and DIACONESCU, M. (2015), *Crustal seismicity and active fault systems in Romania*, Rom. Rep. Phys., 67(3), 1176–1191.
- BASILI, R., KASTELIC, V., VALENSISE, G., and DISS Working Group (2009). DISS3 tutorial series: Guidelines for compiling records of the Database of Individual Seismogenic Sources, version 3, INGV Technical Report 108.
- BOMMER, J.J., SCHERBAUM, F., BUNGUM, H., COTTON, F., SABETTA, F., and ABRAHAMSON, N.A. (2005), *On the use of logic trees for ground-motion prediction equations in seismic-hazard analysis*, Bull. Seismol. Soc. Am., 95, 377–389.
- BOMMER, J.J., and SCHERBAUM, F. (2008), *The use and misuse of logic-trees in probabilistic seismic hazard analysis*, Eq. Spectra 24, 997–1009.
- CAUZZI, C., and FACCIOLI, E. (2008), *Broadband (0.05 to 20 s) prediction of displacement response spectra based on worldwide digital records*, J. Seismol., 12(4), 453–475.
- CORNELL, C.A. (1968), *Engineering seismic analysis*, Bull. Seismol. Soc. Am. 58, 1583–1606.
- COPPERSMITH, K.J., and YOUNGS R.R. (1986), *Capturing uncertainty in probabilistic seismic hazard assessments within intraplate environments*. In: Proceedings of the Third US. National Conference on Earthquake Engineering, August 24–28, 1986, Charleston, USA, Earthquake Engineering Research Institute, El Cerrito CA USA, vol. 1, pp 301–312.
- DELVAUD, E., COTTON, F., AKKAR, S., SCHERBAUM, F., DANCIU, L., BEAUVAL, C., DROUET, S., DOUGLAS, J., BASILI, R., SANDIKKAYA, A., SEGOU, M., FACCIOLI, E., and THEODOULIDIS, N. (2012),



- Toward a ground-motion logic tree for probabilistic seismic hazard assessment in Europe*, J Seismol., 16(3), 451–473.
- DOUGLAS, J., ULRICH, T., and NEGULESCU, C. (2013), *Risk-targeted seismic design maps for mainland France*, Nat. Haz., 65, 1999–2013.
- DOUGLAS, J., ULRICH, T., BERTIL, D., and REY, J. (2014), *Comparisons of the ranges of uncertainty captured in different seismic-hazard studies*, Seismol. Res. Lett., 85, 977–985.
- EN 1998–1:2004 (2004), Eurocode 8: design of structures for earthquake resistance, Part 1: general rules, seismic actions and rules for buildings, Brussels, CEN.
- EPRI (2006), Program on Technology Innovation: Use of Cumulative Absolute Velocity (CAV) in Determining Effects of Small Magnitude Earthquakes on Seismic Hazard Analyses, Report No. 1014099, Palo Alto, California.
- FROHLICH, C. (2006), Deep earthquakes, Cambridge, Cambridge University Press.
- GARDNER, J.K., and KNOPOFF, L. (1974), Is the sequence of earthquakes in southern California, with aftershocks removed, Poissonian?, Bull. Seismol. Soc. Am., 64, 1363–1367.
- ISMAIL-ZADEH, A., MATENCO, L., RADULIAN, M., CLOETINGH, S., and PANZA, G. (2012), *Geodynamics and intermediate-depth seismicity in Vrancea (the south-eastern Carpathians): current state-of-the art*, Tectonophysics, 530–531, 50–79.
- KALE, Ö., and AKKAR, S. (2013), *A new procedure for selecting and ranking ground-motion prediction equations (GMPEs): the Euclidean distance-based ranking (EDR) method*, Bull. Seismol. Soc. Am., 103(2A), 1069–1084.
- KAKLAMANOS, J., BAISE, L.G., and BOORE, D.M. (2011), *Estimating unknown input parameters when implementing the NGA ground-motion prediction equations in engineering practice*, Eq Spectra, 27(4), 1219–1235.
- KIJKO, A. (2004), *Estimation of the maximum earthquake magnitude,  $m_{max}$* , Pure Appl. Geophys., 161, 1655–1681.
- KRAMER, S. (1996), Geotechnical Earthquake Engineering. New Jersey, Upper Saddle River: Prentice Hall.
- KULKARNI, R.B., YOUNGS, R.R., and COPPERSMITH K.J. (1984), Assessment of confidence intervals for results of seismic hazard analysis. In: Proceedings of the Eighth World Conference on Earthquake Engineering, July 21–28, 1984, San Francisco, USA, Prentice-Hall Inc., Englewood Cliffs NJ USA, Vol 1, pp 263–270.
- LEMOINE, A., DOUGLAS, J., and COTTON, F. (2012), *Testing the applicability of correlations between topographic slope and  $V_{s30}$  for Europe*, Bull. Seismol. Soc. Am., 102(6), 2585–2599.
- LIN, P.S., and LEE, C.T. (2008), *Ground-motion attenuation relationships for subduction-zone earthquakes in Northeastern Taiwan*, Bull. Seismol. Soc. Am., 98(1), 220–240.
- LUCO, N., ELLINGWOOD, B., HAMBURGER, R.O., HOOPER, J.D., KIMBALL, J.K., and KIRCHER, C.A. (2007), Risk-targeted versus current seismic design maps for the conterminous United States, Proceedings of the 2007 Structural Engineers Association of California (SEAOC) Convention, Lake Tahoe, CA.
- LUNGU, D., ALDEA, A., ARION, C., DEMETRIU, S., and CORNEA, T. (2000), *Microzonage Sismique de la ville de Bucarest - Roumanie*, Cahier Technique de l'Association Française du Génie Parasismique, 20, 31–63.
- LUNGU, D., DEMETRIU, S., ALDEA, A., and ARION, C. (2006), Probabilistic seismic hazard assessment for Vrancea earthquakes and seismic action in the new seismic code of Romania. Proceedings of the First European Conference on Earthquake Engineering and Seismology, Geneva, paper 1003.
- MÄNTYNIEMI, P., MARZA, V.I., KIJKO, A., and RETIEF, P. (2003), *A new probabilistic seismic hazard analysis for the Vrancea (Romania) seismogenic zone*, Nat. Hazards, 29, 371–385.
- MARMUREANU, G. (2015), *Large Vrancea earthquakes after 1700 (in Romanian)*, AICPS Review, 1–2, 142–151.
- MCGUIRE, R.K. (1976), FORTRAN computer program for seismic risk analysis, US Geological Survey, Open-File Report 76–67.
- MCGUIRE, R. (2004), Seismic hazard and risk analysis, Earthquake Engineering Research Institute MNO-10.
- MUSSON, R.M.W. (2000), *Generalized seismic hazard maps for the Pannonian Basin using probabilistic methods*, Pure Appl. Geophys., 157, 147–169.
- ONCESCU, M.C., MÄRZA, V.I., RIZESCU, M., and POPA, M. (1999), The Romanian earthquake catalogue between 984–1997, In: F. WENZEL, D. LUNGU, O. NOVAK. (Eds.), Vrancea Earthquakes: Tectonics, Hazard and Risk Mitigation, Kluwer Academic Publishers, 43–47.
- ORDAZ, M., MARTINELLI, F., D'AMICO, V., MELETTI, C. (2013), *CRISIS 2008: a flexible tool to perform probabilistic seismic hazard assessment*, Seismol. Res. Lett., 84(3), 495–504.
- P100-1/2013 (2013), Code for seismic design – Part I – Design prescriptions for buildings, Bucharest, Ministry of Regional Development and Public Administration.
- PAVEL, F., VACAREANU, R., ARION, C., and NEAGU, C. (2014a), *On the variability of strong ground motions recorded from Vrancea earthquakes*, Eq. and Struct., 6(1), 1–18.
- PAVEL, F., VACAREANU, R., NEAGU, C., and ARION, C. (2014b), Probabilistic seismic hazard assessment for Romania. Part I: Selection of GMPEs, In: VACAREANU R, IONESCU C, editors. Proceedings of the 5th National Conference on Earthquake Engineering & 1st National Conference on Earthquake Engineering and Seismology, Bucharest, CONSPRESS, p. 213–220.
- PITLAKIS, K., RIGA, E., and ANASTASIADIS, A. (2012), *Design spectra and amplification factors for Eurocode 8*, Bull. Earthq. Eng., 10, 1377–1400.
- RADULIAN, M., MANDRESCU, N., POPESCU, E., UTALE, A., and PANZA, G. (2000), Characterization of Romanian seismic zones, Pure Appl. Geophys., 157, 57–77.
- REITER, L. (1990), Earthquake Hazard Analysis: Issues and Insights, New York, Columbia University Press.
- RYDELEK, P.A., and SACKS, I.S. (1989), Testing the completeness of earthquake catalogs and the hypothesis of self-similarity, Nature, 337, 251–253.
- SCHERBAUM, F., COTTON, F., and SMIT, P. (2004), *On the use of response spectral-reference data for the selection and ranking of ground-motion models for seismic-hazard analysis in regions of moderate seismicity: the case of rock motion*, Bull. Seismol. Soc. Am., 94(6), 2164–2185.
- SCHERBAUM, F., DELAVAUD, E., and RIGGELSEN, E. (2009), *Model selection in seismic hazard analysis: an information theoretic perspective*, Bull. Seismol. Soc. Am., 99(6), 3234–3247.
- SILVA, V., CROWLEY, H., and BAZZURRO, P. (2014), Risk-targeted hazard maps for Europe. Proceedings of the 2nd European Conference on Earthquake Engineering and Seismology, Istanbul, paper no. 1649.
- SIMEONOVA, S.D., SOLAKOV, D.E., LEYDECKER, G., BUSHE, H., SCHMITT, T., and KAISER, D. (2006), *Probabilistic seismic hazard map for Bulgaria as a basis for a new building code*, Nat. Hazards Earth. Syst. Sci., 6, 881–887.

- SOKOLOV, V.Y., BONJER, K.P., WENZEL, F., GRECU, B., and RADULIAN, M. (2008), *Ground-motion prediction equations for the intermediate depth Vrancea (Romania) earthquakes based on Fourier amplitude spectra*. *Bull. Eq. Eng.*, 6(3), 367–388.
- SOKOLOV, V.Y., WENZEL, F., and MOHINDRA, R. (2009), *Probabilistic seismic hazard assessment for Romania and sensitivity analysis: a case of joint consideration of intermediate-depth (Vrancea) and shallow (crustal) seismicity*, *Soil Dyn. Earthq. Eng.*, 29, 364–381.
- STUCCHI, M., ROVIDA, A., GOMEZ CAPERA, A.A., ALEXANDRE, P., CAMELBECK, T., DEMIRCIÖGLU, M.B., GASPERINI, P., KOUSKOUNA, V., MUSSON, R.M.W., RADULIAN, M., SESETYAN, K., VILANOVA, S., BAUMONT, D., BUNGUM, H., FÄH, D., LENHARDT, W., MAKROPOULOS, K., MARTINEZ SOLARES, J.M., SCOTTI, O., ŽIVČIĆ, M., ALBINI, P., BATLLO, J., PAPAIOANNOU, C., TATEVOSSIAN, R., LOCATI, M., MELETTI, C., VIGANÒ, D., and GIARDINI, D. (2013), *The SHARE European Earthquake Catalogue (SHEEC) 1000–1899*, *J. Seismol.*, 17, 523–544.
- VACAREANU, R., PAVEL, F., and ALDEA, A. (2013), *On the selection of GMPEs for Vrancea subcrustal seismic source*, *Bull. Eq. Eng.*, 11(6), 1867–1884.
- VACAREANU, R., LUNGU, D., ALDEA, A., DEMETRIU, S., PAVEL, F., ARION, C., IANCOVICI, M. and NEAGU, C. (2014), Probabilistic seismic hazard assessment for Romania. Part III: seismic hazard maps. In: VACAREANU R, IONESCU C, editors, Proceedings of the 5th National Conference on Earthquake Engineering & 1st National Conference on Earthquake Engineering and Seismology, Bucharest, CONSPRESS, p. 229–236.
- VACAREANU, R., RADULIAN, M., IANCOVICI, M., PAVEL, F., and NEAGU, C. (2015), *Fore-arc and back-arc ground motion prediction model for Vrancea intermediate depth seismic source*, *J. Eq. Eng.*, 19(3), 535–562.
- VANZI, I., MARANO, G.C., MONTI, G., and NUTI, C. (2015), *A synthetic formulation for the Italian seismic hazard and code implications for the seismic risk*, *Soil Dyn. Earthq. Eng.*, 77, 111–122.
- WALD, D.J., and ALLEN, T.I. (2007), *Topographic slope as a proxy for seismic site conditions and amplification*. *Bull. Seismol. Soc. Am.*, 97, 1379–1395.
- WEATHERHILL, G., and DANCIU, L. (2014), A regional perspective on Eurocode 8 seismic inputs in the context of a harmonised European seismic hazard model, Proceedings of the 2nd European Conference on Earthquake Engineering and Seismology, Istanbul, paper no. 3268.
- WENZEL, F., ACHAUER, U., ENESCU, D., KISSLING, E., RUSSO, R., MOCANU, V., and MUSACCHIO, G. (1998), *Detailed look at final stage of plate break-off is target of study in Romania*, *EOS Trans. Am. Geophys. Uni.*, 79(48), 589–600.
- WIEMER, S., and WYSS, M. (2000), *Minimum magnitude of complete reporting in earthquake catalogs: examples from Alaska, the Western United States, and Japan*, *Bull. Seismol. Soc. Am.*, 90, 859–869.
- WOESSNER, J., DANCIU, L., GIARDINI, D., CROWLEY, H., COTTON, F., GRÜNTAL, G., VALENSISE, G., ARVIDSSON, R., BASILI, R., DEMIRCIÖGLU, M.B., HIEMER, S., MELETTI, C., MUSSON, R.M.W., ROVIDA, A.N., SESETYAN, K., STUCCHI, M., and the SHARE Consortium (2015), *The 2013 European Seismic Hazard Model: key components and results*, *Bull. Earthq. Eng.*, doi:10.1007/s10518-015-9795-1.
- YOUNGS, R.R., CHIOU, S.J., SILVA, W.J., and HUMPHREY, J.R. (1997), *Strong ground motion attenuation relationships for subduction zone earthquakes*, *Seismol. Res. Lett.*, 68(1), 58–73.