

Berends-Giele currents in Bern-Carrasco-Johansson gauge for F^3 - and F^4 -deformed Yang-Mills amplitudes

Lucia M. Garozzo,^{a,b} Leonel Queimada^a and Oliver Schlotterer^{a,c}

^a*Perimeter Institute for Theoretical Physics,
31 Caroline St N, Waterloo, Ontario N2L 2Y5, Canada*

^b*Department of Physics and Astronomy, Uppsala University,
Lägerhyddsvägen 1, Uppsala 75237, Sweden*

^c*Max-Planck-Institut für Gravitationsphysik, Albert-Einstein-Institut,
Am Muehlenberg 1, Potsdam 14476, Germany*

E-mail: lucia.garozzo@physics.uu.se,

lquintaqueimada@perimeterinstitute.ca, olivers@aei.mpg.de

ABSTRACT: We construct new representations of tree-level amplitudes in D -dimensional gauge theories with deformations via higher-mass-dimension operators $\alpha' F^3$ and $\alpha'^2 F^4$. Based on Berends-Giele recursions, the tensor structure of these amplitudes is compactly organized via off-shell currents. On the one hand, we present manifestly cyclic representations, where the complexity of the currents is systematically reduced. On the other hand, the duality between color and kinematics due to Bern, Carrasco and Johansson is manifested by means of non-linear gauge transformations of the currents. We exploit the resulting notion of Bern-Carrasco-Johansson gauge to provide explicit and manifestly local double-copy representations for gravitational amplitudes involving $\alpha' R^2$ and $\alpha'^2 R^3$ operators.

KEYWORDS: Scattering Amplitudes, Bosonic Strings, Gauge Symmetry

ARXIV EPRINT: [1809.08103](https://arxiv.org/abs/1809.08103)

Contents

1	Introduction	2
1.1	Outline	4
2	Review and notation	4
2.1	Berends-Giele recursions	5
2.2	Perturbiners as generating series of Berends-Giele currents	7
2.3	Manifestly cyclic reformulation	10
2.4	BCJ duality	11
2.5	Double copy	14
3	Perturbiners and Berends-Giele representations for F^3 and F^4	16
3.1	Berends-Giele recursions for F^3 and F^4	17
3.2	Manifestly cyclic Berends-Giele representations	19
3.3	Gauge algebra of $F^3 + F^4$ building blocks	22
4	Kinematic Jacobi identities in off-shell diagrams	23
4.1	Local multiparticle polarizations up to rank three	24
4.2	Local multiparticle polarizations at rank four and five	27
4.3	Local multiparticle polarizations at higher rank	29
5	BCJ gauge and BCJ numerators for $(\text{YM}+F^3+F^4)$	31
5.1	Berends-Giele currents in BCJ gauge	31
5.2	Kinematic derivation of the BCJ relations	33
5.3	Local Jacobi-satisfying numerators	35
5.4	Relation to string-theory and gravity amplitudes	38
6	Conclusions and outlook	40
A	Properties of the cyclic building blocks	41
A.1	Appearance in the amplitudes	42
A.2	Integration by parts	44
A.3	Gauge algebra	46
B	The explicit form of gauge scalars towards BCJ gauge	49
B.1	The local building block h_{12345}	49
B.2	An alternative expression for H_{1234}	50
B.3	The Berends-Giele version H_{12345}	50
C	Deriving a BCJ representation for $(\text{YM}+F^3+F^4)$ amplitudes	51

1 Introduction

Recent investigations of scattering amplitudes in gauge theories and gravity revealed a wealth of mathematical structures and surprising connections between different theories. For gravitational theories in D spacetime dimensions, traditional methods for tree amplitudes and loop integrands naively give rise to an exasperating proliferation of terms. Still, the final answers for these quantities across various loop- and leg orders take a strikingly simple form: the dependence on the spin-two polarizations can often be reduced to squares of suitably chosen gauge-theory quantities.

The study of double-copy structures in perturbative gravity originates from string theory, where Kawai Lewellen and Tye (KLT) identified universal relations between open- and closed-string tree-level amplitudes [1]. The KLT relations have been later on reformulated in a field-theory framework by Bern, Carrasco and Johansson (BCJ) [2–4] such as to flexibly address multiloop integrands. In this way, numerous long-standing questions on the ultraviolet properties of supergravity theories have been resolved [5–10], bypassing the spurious explosion of terms in intermediate steps.

This double-copy approach to gravitational amplitudes takes a particularly elegant form once a hidden symmetry of gauge-theory amplitudes is manifested — the duality between color and kinematics due to BCJ [2]. At tree level, the BCJ duality in gauge theories has not only been explained and manifested in string theories [11–16] but also extends to various constituents of string-theory amplitudes [17–22]. In particular, the following terms in the gauge-field effective action of the open bosonic string¹ in D spacetime dimensions preserve the BCJ duality to the order of α'^2 [18],

$$\mathcal{S}_{\text{YM}+F^3+F^4} = \int d^D x \text{Tr} \left\{ \frac{1}{4} F_{\mu\nu} F^{\mu\nu} + \frac{2\alpha'}{3} F_{\mu}{}^{\nu} F_{\nu}{}^{\lambda} F_{\lambda}{}^{\mu} + \frac{\alpha'^2}{4} [F_{\mu\nu}, F_{\lambda\rho}] [F^{\mu\nu}, F^{\lambda\rho}] \right\}, \tag{1.1}$$

where $F^{\mu\nu}$ and α' denote the non-abelian field strength and the inverse string tension, respectively. In presence of the effective action (1.1), KLT formulae and BCJ double-copy representations known from Einstein gravity extend² to gravitational tree amplitudes³ from $\alpha'R^2 + \alpha'^2R^3$ operators [18] involving higher powers in the Riemann curvature R . The schematic notation R^2 and R^3 for operators in the gravitational effective action is understood to comprise additional couplings of a B -field and a dilaton φ (such as $e^{-2\varphi}R^2$) known from the low-energy regime of the closed bosonic string [25].

The interplay of higher-mass-dimension operators $D^{2m}F^n$ and $D^{2m}R^n$ in string theories with the BCJ duality and double copy is well understood from the worldsheet de-

¹The low-energy effective action of the open bosonic string involves another operator $\sim \zeta_2 \alpha'^2 F^4$ at the mass dimensions in (1.1) which will not be discussed in this article. Said $\zeta_2 \alpha'^2 F^4$ -operator is also known from the superstring and cannot be reconciled with the BCJ duality [18].

²See [23, 24] for earlier work on the interplay of the KLT relations at the three- and four-point level with gravitational matrix elements of R^2, R^3 operators and F^3, F^4 -deformed gauge-theory amplitudes.

³In slight abuse of terminology, we will usually refer to the matrix elements from higher-mass-dimension operators as “amplitudes”. In the case at hand, we will be interested in contributions from single- or double-insertions of $\alpha'R^2$ operators and single-insertions of α'^2R^3 .

scription of tree-level amplitudes [18, 20–22]. Also, D -dimensional amplitudes of the F^3 operator and their double copy have been studied in the CHY formalism [26]. The purpose of this work is to explore a complementary approach and to manifest the BCJ duality of the $\alpha' F^3 + \alpha'^2 F^4$ operators directly from the Feynman rules of the action (1.1). We will follow some of the ideas in earlier work on ten-dimensional super-Yang-Mills (SYM) [14, 15, 27, 28] and realize the BCJ duality at the level of Berends-Giele currents [29] — up to the order of α'^2 . Further studies of the BCJ duality from a Feynman-diagram perspective, in particular at the level of off-shell currents in axial gauge, can be found in [30, 31].

We will reorganize the Feynman-diagrammatics of $(\alpha' F^3 + \alpha'^2 F^4)$ -deformed Yang-Mills (YM) theory such as to find an explicit off-shell realization of the BCJ duality. The key idea is to remove the deviations from the BCJ duality by applying a concrete non-linear gauge transformation to the generating series of Berends-Giele currents. Our starting point for the currents is Lorenz gauge, and their transformed versions which obey the color-kinematics duality are said to implement *BCJ gauge* in $(\alpha' F^3 + \alpha'^2 F^4)$ -deformed YM theory.⁴

Particular emphasis will be put on the locality properties of our construction, i.e. the absence of spurious kinematic poles in the gauge-theory constituents. Like this, the gravitational amplitudes from $\alpha' R^2 + \alpha'^2 R^3$ operators obtained via double copy reflect the propagator structure of cubic-vertex diagrams and facilitate loop-level applications based on the unitarity method [32–36]. Moreover, locality of the gauge-theory building blocks will be crucial for one of our main results: a kinematic derivation of the BCJ relations [2] among color-ordered amplitudes of $(\text{YM}+F^3+F^4)$ [18], a manifestly gauge invariant formulation of the BCJ duality.

Finally, the complexity of the Berends-Giele currents of $(\text{YM}+F^3+F^4)$ will be systematically shortened by adapting techniques [14, 15, 37, 38] from ten-dimensional SYM. Our manipulations resemble BRST integration by parts of the pure-spinor superstring [39] and allow for manifestly cyclic amplitude representations as well as streamlined expressions for the gauge parameter towards BCJ gauge.

The results of this work on the currents and amplitudes of $(\text{YM}+F^3+F^4)$ are valid up to and including the order of α'^2 . At higher orders in α' , effective operators including $\alpha'^3 D^2 F^4$ as provided by the bosonic string are required to maintain the BCJ duality [18, 21]. Moreover, our results hold in any number D of spacetime dimensions: apart from the critical dimension $D = 26$ of the bosonic string and the phenomenologically interesting situation with $D = 4$, this allows for a flexible unitarity-based investigation of loop integrands in various dimensions and dimensional regularization, see e.g. [40, 41].

By its close contact with Lagrangians, the construction in this work resonates with recent developments in scalar theories with color-kinematics duality and double-copy structures [42, 43]: for the color-kinematics duality of the non-linear sigma model (NLSM) of Goldstone bosons [42], a Lagrangian origin along with the structure constants of a kinematic algebra has been identified in [44]. This new formulation of the NLSM can be derived from higher dimensional YM theory [45], and a string-inspired higher-derivative extension

⁴See [27, 28] for generating series of Berends-Giele currents, their non-linear gauge transformations and BCJ gauge in ten-dimensional SYM.

of the NLSM⁵ [46] has been recently obtained from the analogous dimensional reduction of $\alpha'F^3$ in a companion paper [47]. In view of these connections, we hope that the notion of BCJ gauge inspires a reformulation of the (YM+ F^3 + F^4)-Lagrangian (1.1) where — similar to [44] — the D -dimensional kinematic algebra is manifest.⁶

Another source of motivation for this work stems from the renewed interest in the gravitational $\alpha'R^2 + \alpha'^2R^3$ interactions in $D \neq 4$ dimensions. While R^3 is well-known to be the first (non-evanescent) two-loop counterterm for pure gravity [52, 53], the evanescent one-loop counterterm R^2 was recently found to contaminate dimensional regularization at two loops [54, 55]. Moreover, evanescent matrix elements of R^2 are closely related to certain anomalous amplitudes of $\mathcal{N} = 4$ supergravity [56] through the double copy [57]. Finally, when viewed as ambiguities in defining quantum theories, matrix elements of higher dimensional operators can be crucial to restore symmetries when using a non-ideal regulator for loop amplitudes [58]. We hope that our D -dimensional double-copy representations for tree-level amplitudes of $(\alpha'R^2 + \alpha'^2R^3)$ -deformed gravity shed further light into these loop-level topics: either by unitarity or by using the BCJ-gauge currents as building blocks for loop amplitudes that universally represent tree-level subdiagrams.⁷

1.1 Outline

This work is organized as follows: in section 2, we review the basics of Berends-Giele recursions, the BCJ duality as well as the double copy and establish the associated elements of notation. Section 3 is dedicated to amplitudes of (YM+ F^3 + F^4) in different types of Berends-Giele representations including a systematic reduction of the rank of the currents. In section 4, an explicit off-shell realization of the BCJ duality is obtained from the Berends-Giele setup. Finally, section 5 relates this realization of the BCJ duality to non-linear gauge freedom and combines the off-shell ingredients from the previous section to manifestly local amplitude representations of (YM+ F^3 + F^4) and gravity with $\alpha'R^2 + \alpha'^2R^3$ operators. A derivation of the BCJ relations to the order of α'^2 from purely kinematic arguments is given in section 5.2.

2 Review and notation

In this section, we set up notation and review the key ideas and applications of Berends-Giele recursions for tree-level amplitudes in YM theory, in particular

- the resummation of Berends-Giele currents to obtain perturbative solutions to the non-linear field equations
- manifestly cyclic Berends-Giele representations of YM amplitudes involving currents of smaller rank than naively expected.

⁵Said higher-derivative extension of the NLSM is defined by the $\zeta_2\alpha'^2$ -order of abelian Z-theory [46].

⁶See [48, 49] for earlier Lagrangian-based approaches to the BCJ duality and [50] for a connection with the Drinfeld double of the Lie algebra of vector fields. Also see [51] for the kinematic algebra in the self-dual sectors of $D = 4$ YM theory and gravity.

⁷See for instance [59–62] for the use of tree-level Berends-Giele currents in $D > 4$ -dimensional loop amplitudes of gauge theories with maximal and half-maximal supersymmetry.

We will also review the BCJ duality and the double copy from a perspective which later on facilitates the implementation of these features in tree amplitudes and Berends-Giele currents of $(\text{YM}+F^3+F^4)$ as well as gravity with $\alpha'R^2 + \alpha'^2R^3$ operators.

2.1 Berends-Giele recursions

An efficient approach to determine the tensor structure of D -dimensional tree amplitudes in pure YM theory has been introduced by Berends and Giele in 1987 [29]. The key idea of the reference is to recursively combine all color-ordered Feynman diagrams involving multiple external on-shell legs and a single off-shell leg. This recursion is implemented via currents $J_{12\dots p}^\mu$ that depend on the polarization vectors e_i^μ and lightlike momenta k_i^μ of the external particles $i = 1, 2, \dots, p$ subject to the following on-shell constraints

$$e_i \cdot k_i = k_i \cdot k_i = 0 \quad \forall i = 1, 2, \dots \quad (2.1)$$

While Latin letters i, j, \dots refer to external-state labels, Lorentz-indices $\mu, \nu, \dots = 0, 1, \dots, D-1$ are taken from the Greek alphabet.

Currents of arbitrary multiplicity can be efficiently computed from the Berends-Giele recursion [29]

$$J_i^\mu = e_i^\mu, \quad s_P J_P^\mu = \sum_{XY=P} [J_X, J_Y]^\mu + \sum_{XYZ=P} \{J_X, J_Y, J_Z\}^\mu, \quad (2.2)$$

where

$$[J_X, J_Y]^\mu = (k_Y \cdot J_X) J_Y^\mu - (k_X \cdot J_Y) J_X^\mu + \frac{1}{2}(k_X^\mu - k_Y^\mu)(J_X \cdot J_Y) \quad (2.3)$$

$$\{J_X, J_Y, J_Z\}^\mu = (J_X \cdot J_Z) J_Y^\mu - \frac{1}{2}(J_X \cdot J_Y) J_Z^\mu - \frac{1}{2}(J_Y \cdot J_Z) J_X^\mu. \quad (2.4)$$

The external states have been grouped into multiparticle labels or words $P = 12 \dots p$. We will represent multiparticle labels by capital letters P, Q, X, Y, \dots and denote their length, i.e. the number of labels in $P = 12 \dots p$, by $|P| = p$. The summation over $XY = P$ on the right-hand side of (2.2) instructs to deconcatenate P into non-empty words $X = 12 \dots j$ and $Y = j+1 \dots p$ with $j = 1, 2, \dots, p-1$ and therefore generates $|P|-1$ terms.⁸ Similarly, $XYZ = P$ encodes $\frac{1}{2}(|P|-1)(|P|-2)$ deconcatenations into non-empty words $X = 12 \dots j$, $Y = j+1 \dots l$ and $Z = l+1 \dots p$ with $1 \leq j < l \leq p-1$.

Moreover, the right-hand side of (2.2) involves multiparticle momenta k_P through Mandelstam invariants or inverse propagators s_P

$$k_{P=12\dots p}^\mu = k_1^\mu + k_2^\mu + \dots + k_p^\mu, \quad s_P = \frac{1}{2}k_P^2. \quad (2.5)$$

Finally, the brackets in (2.3) and (2.4) capture the cubic and quartic Feynman vertices of pure YM theory in Lorenz gauge. As depicted in figure 1, the role of the deconcatenations $XY = P$ and $XYZ = P$ in (2.2) is to connect lower-rank currents J_X^μ, J_Y^ν and J_Z^λ via Feynman vertices in all possible ways that preserve the color order of the on-shell legs in the word $P = 12 \dots p$.

⁸For instance, the summation over $XY = P$ with $P = 1234$ of length four incorporates the pairs $(X, Y) = (123, 4), (12, 34)$ and $(1, 234)$.

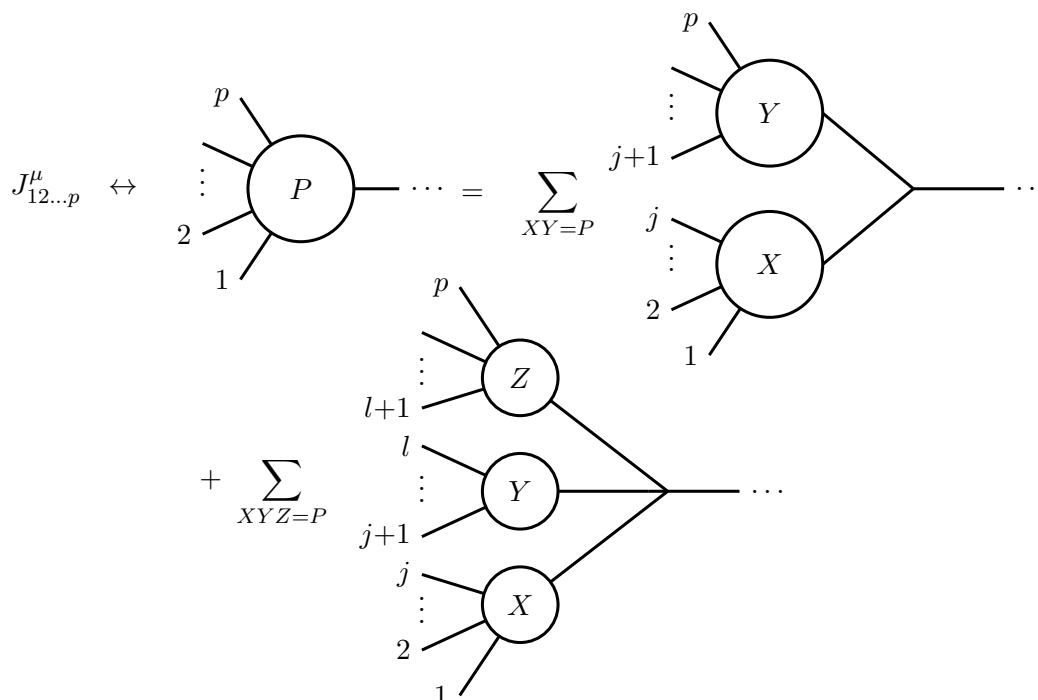

Figure 1. Berends-Giele currents $J_{12\dots p}^\mu$ of rank p combine the diagrams and propagators of a color-ordered $(p+1)$ -point YM tree amplitude with an off-shell leg \dots . The sums in (2.2) gather all combinations of cubic and quartic Feynman vertices that preserve the color order. Like this, $J_{12\dots p}^\mu$ can be computed from quadratic contributions $\sim J_{12\dots j}^\nu J_{j+1\dots p}^\lambda$ with $j = 1, 2, \dots, p-1$ and trilinear ones $\sim J_{12\dots j}^\nu J_{j+1\dots l}^\lambda J_{l+1\dots p}^\rho$ with $1 \leq j < l \leq p-1$.

Accordingly, color-ordered on-shell amplitudes at $n = p+1$ points are recovered by taking the off-shell leg in the rank- p current J_p^μ on shell: this on-shell limit is implemented by contraction with the polarization vector $J_n^\mu = e_n^\mu$ of the last leg and removing the propagator $s_{12\dots p}^{-1}$ in the p -particle channel of J_p^μ which would diverge by n -particle momentum conservation $k_{12\dots p}^2 \rightarrow (-k_n)^2 = 0$ [29],⁹

$$\mathcal{A}_{\text{YM}}(1, 2, \dots, n-1, n) = s_{12\dots n-1} J_{12\dots n-1}^\mu J_n^\mu. \quad (2.6)$$

For instance, the rank-two current due to (2.2) with $X = 1$ and $Y = 2$ yields the following representation of the three-point amplitude

$$s_{12} J_{12}^\mu = (k_2 \cdot e_1) e_2^\mu - (k_1 \cdot e_2) e_1^\mu + \frac{1}{2} (k_1^\mu - k_2^\mu) (e_1 \cdot e_2) \quad (2.7)$$

$$\mathcal{A}_{\text{YM}}(1, 2, 3) = s_{12} J_{12}^\mu J_3^\mu = (k_2 \cdot e_1) (e_2 \cdot e_3) - (k_1 \cdot e_2) (e_1 \cdot e_3) + \frac{1}{2} (e_1 \cdot e_2) e_3 \cdot (k_1 - k_2),$$

where cyclicity may be manifested via $e_3 \cdot k_2 = -e_3 \cdot k_1$ by means of on-shell constraints and momentum conservation. Note that Berends-Giele formulae similar to (2.6) have been given

⁹Here and in later equations of this work, we keep both instances of a contracted Lorentz index in the uppercase position to avoid interference with the multiparticle labels of the currents. The signature of the metric is still taken to be Minkowskian, regardless of the position of the indices.

for tree amplitudes in ten-dimensional SYM [38], doubly-ordered amplitudes of bi-adjoint scalars [63] and worldsheet integrals for tree-level scattering of open strings [64].

The symmetry properties $[J_X, J_Y] = -[J_Y, J_X]$ and $\{J_X, J_Y, J_Z\} + \text{cyc}(X, Y, Z) = 0$ of the brackets in (2.3) and (2.4) imply that the currents in (2.2) obey shuffle symmetry [27, 65]¹⁰

$$J_{P \sqcup Q}^\mu = 0 \quad \forall P, Q \neq \emptyset. \tag{2.8}$$

As pointed out in [28], the amplitude formula (2.6) propagates the shuffle symmetry of the currents to the Kleiss-Kuijff (KK) relations [66, 67]

$$\mathcal{A}_{\text{YM}}((P \sqcup Q), n) = 0 \quad \forall P, Q \neq \emptyset, \tag{2.9}$$

where the words P and Q involve external-state labels $1, 2, \dots, n-1$. In the same way as shuffle symmetry (2.8) leaves $(p-1)!$ independent permutations of rank- p currents $J_{12\dots p}^\mu$, KK relations (2.9) allow to expand color-ordered amplitudes in an $(n-2)!$ -element set [66, 67],

$$J_{P1Q}^\mu = (-1)^{|P|} J_{1(\tilde{P} \sqcup Q)}^\mu, \quad \mathcal{A}_{\text{YM}}(P, 1, Q, n) = (-1)^{|P|} \mathcal{A}_{\text{YM}}(1, (\tilde{P} \sqcup Q), n), \tag{2.10}$$

where $\tilde{P} = p_{|P|} \dots p_2 p_1$ denotes the reversal of the word $P = p_1 p_2 \dots p_{|P|}$.

2.2 Perturbiners as generating series of Berends-Giele currents

The Berends-Giele construction of the previous section can be related to solutions of the non-linear field equations: generating series of Berends-Giele currents turn out to solve the equations of motion from the action \mathcal{S}_{YM} of pure YM theory

$$\mathcal{S}_{\text{YM}} = \frac{1}{4} \int d^D x \text{Tr}(\mathbb{F}_{\mu\nu} \mathbb{F}^{\mu\nu}), \quad \frac{\delta \mathcal{S}_{\text{YM}}}{\delta \mathbb{A}_\lambda} = [\nabla_\mu, \mathbb{F}^{\lambda\mu}]. \tag{2.11}$$

We use the following conventions in deriving the Lie-algebra valued gluon field \mathbb{A}^μ and its non-linear field strength $\mathbb{F}^{\mu\nu}$ from a connection ∇_μ ,

$$\nabla_\mu = \partial_\mu - \mathbb{A}_\mu, \quad \mathbb{F}_{\mu\nu} = -[\nabla_\mu, \nabla_\nu] = \partial_\mu \mathbb{A}_\nu - \partial_\nu \mathbb{A}_\mu - [\mathbb{A}_\mu, \mathbb{A}_\nu]. \tag{2.12}$$

The relation of tree-level amplitudes with solutions of the field equations via generating series goes back to the ‘‘perturbiner’’ formalism [68–72]. In these references, generating series of MHV amplitudes are derived from self-dual YM theory, see [73] for supersymmetric extensions. The connection between perturbiner solutions and the dimension-agnostic Berends-Giele currents of [29] was established in [27, 28] and will now be reviewed.

¹⁰The shuffle product $P \sqcup Q$ of words $P = p_1 p_2 \dots p_{|P|}$ and $Q = q_1 q_2 \dots q_{|Q|}$ is recursively defined by

$$P \sqcup \emptyset = \emptyset \sqcup P = P, \quad P \sqcup Q = p_1(p_2 \dots p_{|P|} \sqcup Q) + q_1(q_2 \dots q_{|Q|} \sqcup P).$$

All currents or amplitudes in this work are understood to obey a linearity property $J_{X+Y}^\mu = J_X^\mu + J_Y^\mu$ when formal sums of words appear in a subscript, e.g. $J_{1 \sqcup 2}^\mu = J_{12+21}^\mu = J_{12}^\mu + J_{21}^\mu$ from $1 \sqcup 2 = 12 + 21$.

Lorenz gauge $\partial_\mu \mathbb{A}^\mu = 0$ simplifies the equations of motion $[\nabla_\mu, \mathbb{F}^{\lambda\mu}] = 0$ to the wave equation with the notation $\square = \partial_\mu \partial^\mu$ for the d'Alembertian,

$$\begin{aligned} \square \mathbb{A}^\lambda &= [\mathbb{A}^\mu, \partial_\mu \mathbb{A}^\lambda] + [\mathbb{A}_\mu, \mathbb{F}^{\mu\lambda}] \\ &= 2[\mathbb{A}^\mu, \partial_\mu \mathbb{A}^\lambda] + [\partial^\lambda \mathbb{A}^\mu, \mathbb{A}_\mu] + [[\mathbb{A}^\mu, \mathbb{A}^\lambda], \mathbb{A}_\mu]. \end{aligned} \tag{2.13}$$

One can derive formal solutions to (2.13) by means of the perturbative ansatz

$$\begin{aligned} \mathbb{A}^\mu(x) &= \sum_i J_i^\mu t^{a_i} e^{k_i \cdot x} + \sum_{i,j} J_{ij}^\mu t^{a_i} t^{a_j} e^{k_{ij} \cdot x} + \sum_{i,j,l} J_{ijl}^\mu t^{a_i} t^{a_j} t^{a_l} e^{k_{ijl} \cdot x} + \dots \\ &= \sum_{P \neq \emptyset} J_P^\mu t^P e^{k_P \cdot x}, \quad \text{where } t^{12\dots p} = t^1 t^2 \dots t^p. \end{aligned} \tag{2.14}$$

The summation variables $i, j, l, \dots = 1, 2, 3, \dots$ refer to external-particle labels in an unbounded range, and we have introduced a compact notation $\sum_{P \neq \emptyset}$ for sums over nonempty words $P = 12\dots p$ in passing to the second line. The dependence on the spacetime coordinates x^μ enters through plane waves¹¹ $e^{k_P \cdot x}$, see (2.5) for the multiparticle momenta k_P . The color degrees of freedom in (2.14) are represented through matrix products of the Lie-algebra generators t^{a_i} whose adjoint indices a_1, a_2, \dots are associated with an unspecified gauge group.

Upon insertion into the second line of (2.13), the perturbative ansatz (2.14) can be verified to solve the non-linear field equations $[\nabla_\mu, \mathbb{F}^{\lambda\mu}] = 0$ if its coefficients J_P^μ obey the Berends-Giele recursion (2.2). Hence, generating series of Berends-Giele currents are formal solutions to the field equations.¹² By the shuffle symmetry (2.8) of the currents J_P^μ , the matrix products $t^{a_i} t^{a_j}$ of the Lie-algebra generators on the right-hand side of (2.14) conspire to nested commutators, and the perturbative solution is guaranteed to be Lie-algebra valued [74].

As a convenient reorganization of the Berends-Giele recursion (2.2), one can write the field equations as in the first line of (2.13) and insert a separate perturbative expansion for the non-linear field strength,

$$\mathbb{F}^{\mu\nu}(x) = \sum_{P \neq \emptyset} B_P^{\mu\nu} t^P e^{k_P \cdot x} \quad \Rightarrow \quad B_P^{\mu\nu} = k_P^\mu J_P^\nu - k_P^\nu J_P^\mu - \sum_{P=XY} (J_X^\mu J_Y^\nu - J_X^\nu J_Y^\mu). \tag{2.15}$$

The expressions for the field-strength currents $B_P^{\mu\nu}$ in terms of J_Q^λ are determined by the definition (2.12) of $\mathbb{F}^{\mu\nu}$, and their non-linear terms $\sum_{P=XY} J_X^\mu J_Y^\nu$ have already been studied in [75]. Then, inserting (2.14) and (2.15) into (2.13) yields a simpler but equivalent form of the recursion (2.2) [28]

$$J_P^\mu = \frac{1}{2s_P} \sum_{P=XY} \left[(k_Y \cdot J_X) J_Y^\mu + J_X^\nu B_Y^{\nu\mu} - (X \leftrightarrow Y) \right]. \tag{2.16}$$

¹¹The conventional form of plane waves $e^{ik \cdot x}$ with an imaginary unit in the exponent can be recovered by redefining the momenta in this work as $k \rightarrow ik$. The equations in the main text follow the conventions where external momenta are purely imaginary in order to keep factors of i from proliferating.

¹²Strictly speaking, contributions with several factors of t^{a_j} referring to the same external leg j need to be manually suppressed by adding nilpotent symbols to the perturbative ansatz [68]. For ease of notation, we do not include these symbols into the equations in the main text, and all terms with repeated appearance of a given external leg are understood to be suppressed.

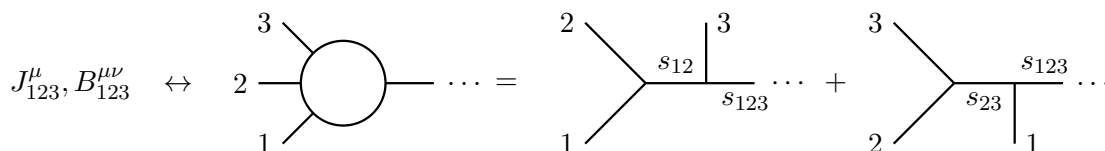

Figure 2. By pairing up the two types of Berends-Giele currents $J_{12\dots p}^\mu$ and $B_{12\dots p}^{\mu\nu}$, only cubic-vertex diagrams have to be considered in their recursive construction from lower-rank currents. In the depicted example at rank $p = 3$ with an additional off-shell leg \dots , only two cubic diagrams of s -channel and t -channel type contribute to the four-point amplitude obtained from $s_{123}J_{123}^\mu J_4^\mu$.

The trilinear term $\{J_X, J_Y, J_Z\}$ in (2.4) which represents the quartic vertex of the YM Lagrangian has been absorbed into the non-linear part of the field-strength current $B_P^{\mu\nu}$ in (2.15). The leftover deconcatenations $P = XY$ in (2.16) can be interpreted as describing cubic diagrams, see figure 1. Let us illustrate this statement with the four-point amplitude $s_{123}J_{123}^\mu J_4^\mu$ derived from a rank-three current via (2.6): the two deconcatenations $(X, Y) = (12, 3)$ and $(1, 23)$ in the recursion (2.16) for J_{123}^μ can be viewed as the two cubic diagrams in figure 2 where appropriate contributions from the quartic vertex (2.4) are automatically included.

Note that the Lorenz-gauge condition and the field equations imply the relations

$$k_P \cdot J_P = 0, \quad k_P^\mu B_P^{\mu\nu} = \sum_{XY=P} (J_X^\mu B_Y^{\mu\nu} - J_Y^\mu B_X^{\mu\nu}) \quad (2.17)$$

including transversality of the gluon polarizations for single-particle labels $P = i$. Moreover, the non-linear gauge symmetry of the action (2.11) under $\delta_\Omega \mathbb{A}^\mu = \partial^\mu \Omega - [\mathbb{A}^\mu, \Omega]$ and $\delta_\Omega \mathbb{F}^{\mu\nu} = -[\mathbb{F}^{\mu\nu}, \Omega]$ acts on the currents via

$$\delta_\Omega J_P^\mu = k_P^\mu \Omega_P - \sum_{XY=P} (J_X^\mu \Omega_Y - J_Y^\mu \Omega_X), \quad \delta_\Omega B_P^{\mu\nu} = - \sum_{XY=P} (B_X^{\mu\nu} \Omega_Y - B_Y^{\mu\nu} \Omega_X). \quad (2.18)$$

The scalar currents Ω_P are defined by the perturbative expansion $\Omega(x) = \sum_{P \neq \emptyset} \Omega_P t^P e^{k_P \cdot x}$ of the gauge scalar in δ_Ω . We will later on spell out a choice of gauge-scalar currents Ω_P which manifests the BCJ duality at the level of Berends-Giele currents.

Another specific choice of $\Omega_P \rightarrow \Omega_P^{\text{lin}}$ allows to track the effect of linearized gauge transformations $e_i^\mu \rightarrow k_i^\mu$ on the i^{th} leg of the Berends-Giele currents in (2.18): one can line up the replacement $e_i^\mu \rightarrow k_i^\mu$ with a set of gauge transformations that preserves Lorenz gauge. The condition $\delta_{\Omega^{\text{lin}}}(\partial_\mu \mathbb{A}^\mu) = \partial_\mu(\delta_{\Omega^{\text{lin}}} \mathbb{A}^\mu) = 0$ then translates into the recursion [27]

$$\Omega_P^{\text{lin}} = \frac{1}{2s_P} \sum_{XY=P} ((k_Y \cdot J_X) \Omega_Y^{\text{lin}} - (k_X \cdot J_Y) \Omega_X^{\text{lin}}) \quad (2.19)$$

which needs to be supplemented with the initial conditions $\Omega_j^{\text{lin}} \rightarrow \delta_{i,j}$ if the linearized gauge transformations $e_i^\mu \rightarrow k_i^\mu$ only applies to the i^{th} leg. Precursors of the formula (2.19) for linearized gauge transformations of Berends-Giele currents can be found in [65].

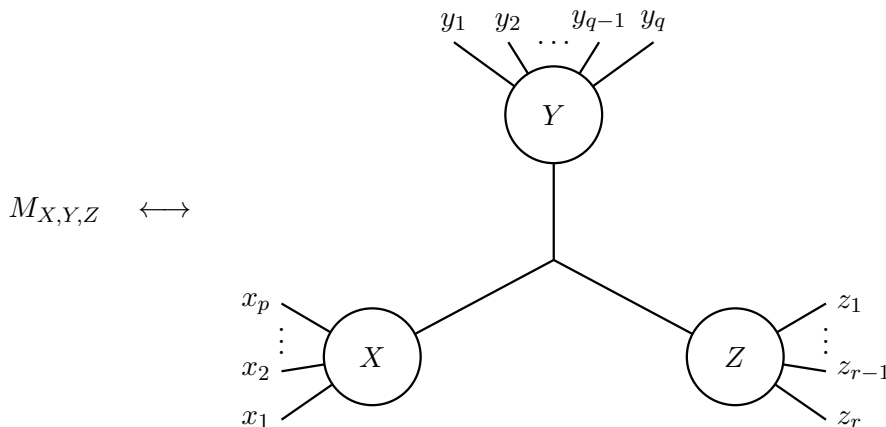

Figure 3. Diagrammatic interpretation of the building block $M_{X,Y,Z}$ in (2.20) with multiparticle labels $X = x_1 x_2 \dots x_p$, $Y = y_1 y_2 \dots y_q$ and $Z = z_1 z_2 \dots z_r$.

2.3 Manifestly cyclic reformulation

Given that the Berends-Giele formula (2.6) for color-ordered amplitudes $\mathcal{A}_{\text{YM}}(1, 2, \dots, n)$ singles out the last leg n which is excluded from the current $J_{12\dots n-1}^\mu$, cyclic invariance in the external legs is obscured. We shall now review a reorganization of the Berends-Giele currents for YM tree amplitudes such that the n^{th} leg enters on completely symmetric footing. Moreover, the subsequent rewritings reduce n -point amplitudes to shorter Berends-Giele currents of rank $\leq \frac{n}{2}$ instead of the rank- $(n-2)$ currents in the recursion (2.2) for $J_{12\dots n-1}^\mu$.

The backbone of the manifestly cyclic Berends-Giele formulae is the building block [28]

$$M_{X,Y,Z} = \frac{1}{2} (J_X^\mu B_Y^{\mu\nu} J_Z^\nu + J_Y^\mu B_Z^{\mu\nu} J_X^\nu + J_Z^\mu B_X^{\mu\nu} J_Y^\nu) = \frac{1}{2} J_X^\mu B_Y^{\mu\nu} J_Z^\nu + \text{cyc}(X, Y, Z) \quad (2.20)$$

composed of three currents with multiparticle labels X, Y, Z each of which represents tree-level subdiagrams. The resulting diagrammatic interpretation of $M_{X,Y,Z}$ is depicted in figure 3, and the definition (2.20) along with $B_X^{\mu\nu} = -B_X^{\nu\mu}$ implies permutation antisymmetry $M_{X,Y,Z} = -M_{Y,X,Z}$ and $M_{X,Y,Z} = M_{Y,Z,X}$ expected from the cubic vertex in the figure.

Using $k_P \cdot J_P = 0$ and $k_X + k_Y + k_Z = 0$, it was shown in [28] that the n -point amplitude (2.6) can be rewritten as

$$\mathcal{A}_{\text{YM}}(1, 2, \dots, n-1, n) = \sum_{XY=12\dots n-1} M_{X,Y,n} = \sum_{j=1}^{n-2} M_{12\dots j, j+1\dots n-1, n}. \quad (2.21)$$

As demonstrated in appendix A.2, momentum conservation $k_P + k_Q = 0$ and (2.17) imply the following identity

$$\sum_{XY=P} M_{X,Y,Q} = \sum_{XY=Q} M_{P,X,Y}, \quad (2.22)$$

which will be referred to as “integration by parts”¹³ and reads as follows in simple examples,

$$\begin{aligned}
 M_{12,3,4} &= M_{1,2,3,4}, & M_{123,4,5} &= M_{12,3,4,5} + M_{1,23,4,5} \\
 M_{1234,5,6} &= M_{123,4,5,6} + M_{12,34,5,6} + M_{1,234,5,6} \\
 M_{123,45,6} + M_{123,4,5,6} &= M_{12,3,45,6} + M_{1,23,45,6}.
 \end{aligned}
 \tag{2.23}$$

By repeated application to the amplitude representation (2.21), one can derive the following manifestly cyclic representations

$$\begin{aligned}
 \mathcal{A}_{\text{YM}}(1, 2, 3, 4) &= \frac{1}{2}M_{12,3,4} + \text{cyc}(1, 2, 3, 4) \\
 \mathcal{A}_{\text{YM}}(1, 2, \dots, 5) &= M_{12,3,4,5} + \text{cyc}(1, 2, 3, 4, 5) \\
 \mathcal{A}_{\text{YM}}(1, 2, \dots, 6) &= \frac{1}{3}M_{12,34,5,6} + \frac{1}{2}(M_{123,45,6} + M_{123,4,5,6}) + \text{cyc}(1, 2, \dots, 6) \\
 \mathcal{A}_{\text{YM}}(1, 2, \dots, 7) &= M_{123,45,6,7} + M_{1,234,5,6,7} + \text{cyc}(1, 2, \dots, 7).
 \end{aligned}
 \tag{2.24}$$

Note in particular that the rank of the currents in the manifestly cyclic n -point amplitudes (2.24) is bounded by¹⁴ $\lfloor \frac{n}{2} \rfloor$ rather than $n-2$ as expected from the recursions (2.2) or (2.16) for $J_{12\dots n-1}^\mu$. In section 3, similar expressions with manifest cyclicity and Berends-Giele currents of maximum rank $\lfloor \frac{n}{2} \rfloor$ will be given for the deformed (YM+ F^3 + F^4) theory.

2.4 BCJ duality

The organization of the Berends-Giele recursion (2.16) in terms of cubic-vertex diagrams as exemplified in figure 2 resonates with the BCJ duality between color and kinematics [2]: according to the BCJ duality, scattering amplitudes in non-abelian gauge theories can be represented in a manner such that color degrees of freedom can be freely interchanged with the kinematic variables. While “color” refers to contractions of structure constants $f^{a_i a_j a_k}$, polarizations and momenta are referred to as “kinematics”, and the notion of “freely interchanging” will be shortly made precise. The three-index structure of the contracted structure constants can be visualized via cubic-vertex diagrams with a factor of $f^{a_i a_j a_k}$ for each vertex and contractions of the adjoint indices along the internal edges. Similarly, the kinematic dependence on e_i^μ, k_i^μ should also be organized in terms of cubic diagrams to manifest the BCJ duality.

The non-linear extension $\sum_{XY=P} J_X^\mu J_Y^\nu$ of the field-strength current $B_P^{\mu\nu}$ in (2.15) absorbs the contributions from the quartic vertex $\text{Tr}[\mathbb{A}_\mu, \mathbb{A}_\nu][\mathbb{A}^\mu, \mathbb{A}^\nu]$ in the YM action (2.11). This can be seen from that fact that the non-linear terms have fewer propagators than the rest of (2.16). Hence, the use of field-strength currents amounts to inserting $1 = \frac{k_P^2}{k_P^2}$ such that a quartic vertex is “pulled apart” into two cubic vertices connected by the “fake”

¹³This terminology goes back to the fact that the building block (2.20) and the amplitude representation (2.21) descend from ten-dimensional SYM [28, 38]: in the setup of these references, (2.22) is a consequence of BRST integration by parts in pure-spinor superspace [39].

¹⁴Earlier examples of such economic and manifestly cyclic Berends-Giele representations have been investigated in [76], but the construction in the reference requires a mixture of quadratic, cubic and quartic combinations of Berends-Giele currents instead of a single building block (2.20).

$$\begin{array}{c} 2 \\ \diagdown \\ 1 \end{array} \begin{array}{c} \diagup \\ 3 \\ 4 \end{array} = \frac{(k_1 + k_2)^2}{(k_1 + k_2)^2} \begin{array}{c} 2 \\ \diagdown \\ 1 \end{array} \begin{array}{c} \diagup \\ 3 \\ 4 \end{array} = (k_1 + k_2)^2 \begin{array}{c} 2 \\ \diagdown \\ 1 \end{array} \begin{array}{c} \diagup \\ 3 \\ 4 \end{array}$$

Figure 4. Quartic vertices can always be reorganized in products of cubic vertices, i.e. gauge-theory amplitudes can always be parametrized in terms.

propagator k_P^2 . The choice of the channel P in $1 = \frac{k_P^2}{k_P^2}$ has to be compatible with the color dressing $f^{abe} f^{ecd}$ of the quartic vertex, where ambiguities arise from the Jacobi relations

$$f^{abe} f^{ecd} + f^{ace} f^{edb} + f^{ade} f^{ebc} = 0. \quad (2.25)$$

In figure 4, this situation is visualized in a four-point tree-level context, but there is no limitation to cubic-diagram parametrizations of n -point tree amplitudes as well as multiloop integrands [3, 4]. Although the BCJ duality conjecturally applies to loop integrands [3, 4], we shall focus on its well-established tree-level incarnation.

Of course, contributions from the higher-order vertices of $(\text{Tr } F^3)$ - and $(\text{Tr } F^4)$ -type can also be cast into a cubic-graph form by repeated insertions of $1 = \frac{k_P^2}{k_P^2}$. For the action (1.1) of $(\text{YM} + F^3 + F^4)$, the color structure of the F^3 and F^4 operators also boils down to contracted structure constants [18], and the ambiguities due to Jacobi identities (2.25) arise in this situation as well. In the subsequent review of the BCJ duality, the color-dressed tree-level amplitudes

$$\mathcal{M}_n = \sum_{\rho \in S_{n-1}} \text{Tr}(t^{a_1} t^{a_{\rho(2)}} t^{a_{\rho(3)}} \dots t^{a_{\rho(n)}}) \mathcal{A}(1, \rho(2), \rho(3), \dots, \rho(n)) \quad (2.26)$$

may refer to pure YM ($\mathcal{A} \rightarrow \mathcal{A}_{\text{YM}}$), to its $(\alpha' F^3 + \alpha'^2 F^4)$ -deformation ($\mathcal{A} \rightarrow \mathcal{A}_{\text{YM} + F^3 + F^4}$) or to any other generalization that obeys the BCJ duality. Once the kinematic dependence of (2.26) is absorbed into cubic diagrams I, J, K, \dots , one can choose a parametrization [2]

$$\mathcal{M}_n = \sum_{I \in \Gamma_n} \frac{C_I N_I}{\prod_{\substack{e \in \text{internal} \\ \text{edges of } I}} s_e}, \quad (2.27)$$

where Γ_n denotes the set of cubic tree-level graphs with n external legs. The color factors C_I represent the contracted structure constants that arise from the traces in (2.26). The kinematic numerators N_I are combinations of e_i^μ and k_i^μ that can be assembled from the Berends-Giele currents of the theory. Finally, the propagators s_e^{-1} comprise Mandelstam variables (2.5) for the multiparticle momenta in the internal edges e of the graph I .

The parametrization (2.27) is said to manifest the BCJ duality if all the symmetries of the color factors C_I carry over to the kinematic numerators N_I . More specifically [2]:

- If two graphs I and \hat{I} are related by a single flip of a cubic vertex, antisymmetry $f^{a_i a_j a_k} = f^{[a_i a_j a_k]}$ implies the color factors to have a relative minus sign. In a

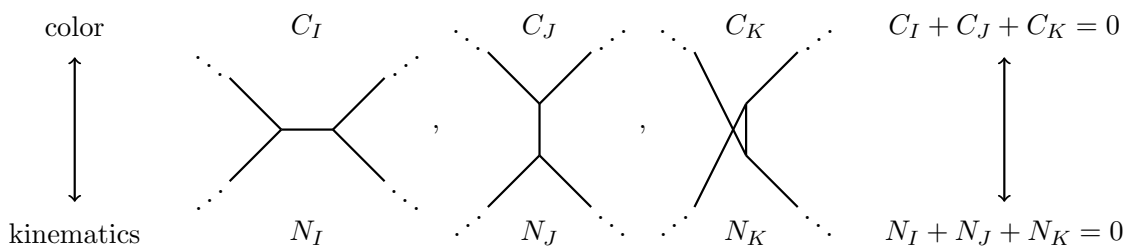

Figure 5. Triplets of cubic graphs I, J, K whose color factors C . and kinematic factors N . are both related by a Jacobi identity if the duality between color and kinematics is manifest. The dotted lines at the corners represent arbitrary tree-level subdiagrams and are understood to be the same for all of the three cubic graphs.

duality-satisfying representation (2.27), the kinematic numerators exhibit the same antisymmetry properties under flips:

$$C_{\hat{I}} = -C_I \implies N_{\hat{I}} = -N_I. \tag{2.28}$$

- For each triplet of graphs I, J, K where the Jacobi identities (2.25) lead to the vanishing of triplets $C_I + C_J + C_K$, the BCJ duality requires the corresponding triplet of kinematic numerators to vanish as well

$$C_I + C_J + C_K = 0 \implies N_I + N_J + N_K = 0. \tag{2.29}$$

As visualized in figure 5, such triplets of cubic graphs only differ by a single propagator.

In later sections, we will construct local representatives of the kinematic numerators N_I in (2.27) of $(YM+F^3+F^4)$ which do not exhibit any poles in s_P and obey the BCJ duality up to and including the order of α'^2 . By the Jacobi identities (2.25) of the color factors, the numerators are still far from unique after imposing locality, and generic choices at $n \geq 5$ points will fail to obey some of the kinematic Jacobi relations (2.29). Hence, finding a manifestly color-kinematics dual parametrization (2.27) requires some systematics in addressing quartic and higher-order vertices via $1 = \frac{k_P^2}{k_P^2}$. The additional requirement of locality is particularly restrictive, and we will see that suitable gauge transformations (2.18) of the Berends-Giele currents in $(YM+F^3+F^4)$ give rise to local solutions, generalizing the construction in ten-dimensional SYM [28].

Still, the very existence of duality satisfying kinematic numerators is sufficient to derive BCJ relations among color-ordered amplitudes [2]

$$\sum_{j=2}^{n-1} (k_{23\dots j} \cdot k_1) \mathcal{A}(2, 3, \dots, j, 1, j+1, \dots, n) = 0. \tag{2.30}$$

By combining different relabellings of (2.30), any color-ordered amplitude can be expanded in a basis of size $(n-3)!$. BCJ relations were shown to apply to $\mathcal{A} \rightarrow \mathcal{A}_{YM+F^3+F^4}$ up to and

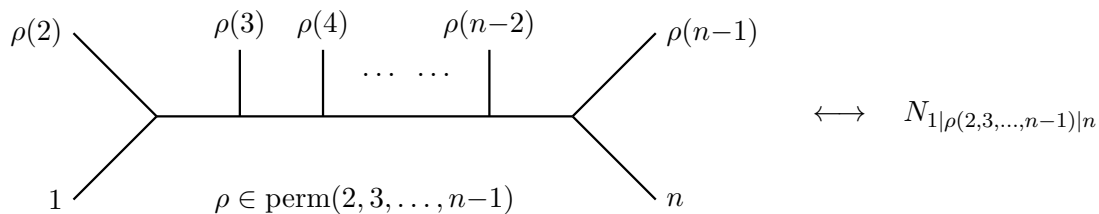

Figure 6. When the BCJ duality is manifest, the master numerators $N_{1|\rho(2,3,\dots,n-1)|n}$ associated with the depicted $(n-2)!$ -family of half-ladder diagrams generate all other kinematic numerators via Jacobi relations.

including the order of α'^2 [18] by isolating suitable terms in the monodromy relations of open-string tree-level amplitudes [11, 12]. For a variety of four-dimensional helicity configurations, kinematic numerators of $\text{YM} + F^3$ subject to Jacobi relations (2.29) can be found in [18]. We will derive generalizations to helicity-agnostic expressions in D dimensions and include the α'^2 order of $(\text{YM} + F^3 + F^4)$.

Kinematic antisymmetry relations (2.28) and Jacobi identities (2.29) leave $(n-2)!$ independent instances of N_I . A basis of kinematic numerators under these relations can be assembled from the “half-ladder” diagrams depicted in figure 6 which are characterized by a fixed choice of endpoints 1 and n as well as permutations $\rho \in S_{n-2}$ of the remaining legs $2, 3, \dots, n-1$. We will denote the basis numerators of the half-ladder diagrams in figure 6 by $N_{1|\rho(2,3,\dots,n-1)|n}$ and refer to them as “master numerators”.

2.5 Double copy

The BCJ duality allows to convert cubic-graph parametrizations (2.27) of gauge-theory amplitudes into gravitational ones: once the gauge-theory numerators N_I satisfy the same symmetry properties as the color factors C_I (i.e. flip antisymmetry (2.28) and kinematic Jacobi identities (2.29)), then the double-copy formula

$$\mathcal{M}_n^{\text{grav}} = \sum_{I \in \Gamma_n} \frac{N_I \tilde{N}_I}{\prod_{\substack{e \in \text{internal} \\ \text{edges of } I}} s_e} \tag{2.31}$$

enjoys linearized-diffeomorphism invariance. In case of undeformed YM theory, (2.31) yields tree-level amplitudes of Einstein-gravity including B -fields, dilatons and tentative supersymmetry partners [2, 48]. The polarizations of external gravitons, B -fields or dilatons in the j^{th} leg are obtained by projecting the tensor products $e_j^\mu \tilde{e}_j^\nu$ in (2.31) to the suitable irreducible representation of the Lorentz group.

In case of $(\text{YM} + F^3 + F^4)$ -numerators, the gravitational amplitudes descend from a deformation of the Einstein-Hilbert action by higher-curvature operators of $\alpha' R^2 + \alpha'^2 R^3$ [18] as seen in the low-energy effective action of the closed bosonic string [25], see section 5.4 for details. The tilde along with the second copy \tilde{N}_I of the gauge-theory numerator N_I indicates that the i^{th} external gravitational state may arise from the tensor product of different polarization vectors e_i^μ and \tilde{e}_i^μ .

In the same way as (2.31) is obtained from gauge-theory amplitudes (2.27) by trading color for kinematics, $C_I \rightarrow \tilde{N}_I$, one can investigate the converse replacement $N_I \rightarrow \tilde{C}_I$:

$$\mathcal{M}_n^{\phi^3} = \sum_{I \in \Gamma_n} \frac{C_I \tilde{C}_I}{\prod_{e \in \text{internal edges of } I} S_e}. \quad (2.32)$$

This double copy of color factors (with \tilde{C}_I comprising structure constants $\tilde{f}^{\tilde{b}_i \tilde{b}_j \tilde{b}_k}$ of possibly different Lie algebra generators $\tilde{t}^{\tilde{b}}$) describes tree amplitudes of biadjoint scalars $\phi = \phi_{a|\tilde{b}} t^a \otimes \tilde{t}^{\tilde{b}}$ with a cubic interaction $f^{a_1 a_2 a_3} \tilde{f}^{\tilde{b}_1 \tilde{b}_2 \tilde{b}_3} \phi_{a_1|\tilde{b}_1} \phi_{a_2|\tilde{b}_2} \phi_{a_3|\tilde{b}_3}$ [77]. The two species t^a and $\tilde{t}^{\tilde{b}}$ admit a two-fold color decomposition (2.26), and we define its doubly-partial amplitudes $m(\cdot|\cdot)$ by peeling off two traces with possibly different orderings $\rho, \tau \in S_{n-1}$ [77],

$$m(1, \rho(2, \dots, n)|1, \tau(2, \dots, n)) = \mathcal{M}_n^{\phi^3} \Big|_{\text{Tr}(t^{a_1} t^{a_{\rho(2)}} \dots t^{a_{\rho(n)}}) \text{Tr}(\tilde{t}^{\tilde{b}_1} \tilde{t}^{\tilde{b}_{\tau(2)}} \dots \tilde{t}^{\tilde{b}_{\tau(n)}})}. \quad (2.33)$$

Doubly-partial amplitudes compactly encode a solution to all the kinematic Jacobi relations: when reducing the gravitational amplitude (2.31) to the master numerators introduced in figure 6, the coefficients are analogous $(n-2)! \times (n-2)!$ families of (2.33)

$$\mathcal{M}_n^{\text{grav}} = \sum_{\rho, \tau \in S_{n-2}} N_{1|\rho(2, \dots, n-1)|n} m(1, \rho(2, \dots, n-1), n|1, \tau(2, \dots, n-1), n) \tilde{N}_{1|\tau(2, \dots, n-1)|n}. \quad (2.34)$$

The gauge-theory analogue (with $C_{1|\rho(2, \dots, n-1)|n}$ referring to the half-ladder diagrams as in figure 6)

$$\mathcal{M}_n = \sum_{\rho, \tau \in S_{n-2}} C_{1|\rho(2, \dots, n-1)|n} m(1, \rho(2, \dots, n-1), n|1, \tau(2, \dots, n-1), n) N_{1|\tau(2, \dots, n-1)|n} \quad (2.35)$$

is equivalent to expansions of color-ordered amplitudes in terms of master numerators [14, 77]

$$\mathcal{A}(\rho(1, 2, \dots, n)) = \sum_{\tau \in S_{n-2}} m(\rho(1, 2, \dots, n)|1, \tau(2, \dots, n-1), n) N_{1|\tau(2, \dots, n-1)|n}. \quad (2.36)$$

Representations of the form in (2.34) to (2.36) arise naturally from the $(\alpha' \rightarrow 0)$ -limit of string-theory amplitudes [14, 19, 20, 63] and the CHY formalism [77].

By comparing the representations (2.27) and (2.35) of color-dressed gauge-theory amplitudes, we conclude that the Jacobi relations among the cubic diagrams in figure 5 can be traced back to the properties of the doubly-partial amplitudes. By the symmetric role of N and C in (2.35), this applies to the Jacobi relations of both color factors and kinematic numerators.

Doubly-partial amplitudes obey BCJ relations (2.30) in both of their entries and admit bases of $(n-3)! \times (n-3)!$ elements [77]. The matrix inverse of such a basis appears in the more traditional formulation of the gravitational double copy at tree level: the $(\alpha' \rightarrow 0)$ limit of the string-theory KLT relations [1] yields the following manifestly diffeomorphism invariant rewriting of (2.31),

$$\mathcal{M}_n^{\text{grav}} = \sum_{\rho, \tau \in S_{n-3}} \mathcal{A}(1, \rho(2, \dots, n-2), n-1, n) S(\rho|\tau)_1 \tilde{\mathcal{A}}(1, \tau(2, \dots, n-2), n, n-1). \quad (2.37)$$

The all-multiplicity form of the $(n-3)! \times (n-3)!$ KLT-matrix $S(\rho|\tau)_1$ has been studied in [78, 79] and furnishes the inverse of doubly-partial amplitudes (2.33) [77],

$$S(\rho|\tau)_1 = -m^{-1}(1, \rho(2, \dots, n-2), n-1, n|1, \tau(2, \dots, n-2), n, n-1). \quad (2.38)$$

Alternatively, one can obtain the KLT matrix from the recursion [46, 79]

$$S(2|2)_1 = k_1 \cdot k_2, \quad S(A, j|B, j, C)_1 = k_j \cdot (k_1 + k_B)S(A|B, C)_1. \quad (2.39)$$

The subscript $_1$ indicates that the entries of (2.38) not only depend on the momenta k_2, \dots, k_{n-2} subject to permutations ρ, τ but also on k_1 .

Similarly, the doubly-partial amplitudes (2.33) can be generated from a Berends-Giele formula analogous to (2.6) [63]

$$m(P, n|Q, n) = s_P \phi_{P|Q}, \quad (2.40)$$

where P and Q are permutations of legs $1, 2, \dots, n-1$, and the doubly-ordered currents $\phi_{P|Q}$ obey the following recursion [63]:

$$\phi_{i|j} = \delta_{ij}, \quad s_P \phi_{P|Q} = \sum_{XY=P} \sum_{AB=Q} (\phi_{X|A} \phi_{Y|B} - \phi_{Y|A} \phi_{X|B}). \quad (2.41)$$

We will often gather rank- r currents (2.41) in the following $(r-1)! \times (r-1)!$ matrix

$$\Phi(P|Q)_1 = \phi_{1P|1Q} = S^{-1}(P|Q)_1. \quad (2.42)$$

Examples for the output of the recursions (2.39) and (2.41) include $\Phi(2|2)_1 = s_{12}^{-1}$ and

$$S(\rho(2, 3)|\tau(2, 3))_1 = \begin{pmatrix} s_{12}(s_{13}+s_{23}) & s_{12}s_{13} \\ s_{12}s_{13} & s_{13}(s_{12}+s_{23}) \end{pmatrix} \quad (2.43)$$

$$\Phi(\rho(2, 3)|\tau(2, 3))_1 = \frac{1}{s_{123}} \begin{pmatrix} s_{12}^{-1}+s_{23}^{-1} & -s_{23}^{-1} \\ -s_{23}^{-1} & s_{13}^{-1}+s_{23}^{-1} \end{pmatrix}.$$

We will later on use the matrices $S(P|Q)_1$ and $\Phi(P|Q)_1$ to relate shuffle independent Berends-Giele currents to kinematic numerators subject to Jacobi identities.

3 Perturbiners and Berends-Giele representations for F^3 and F^4

In this section, we apply the Berends-Giele methods of sections 2.1 to 2.3 to the deformed $(\text{YM}+F^3+F^4)$ theory known from the low-energy regime of open bosonic strings. The tree-level amplitudes following from the action

$$\mathcal{S}_{\text{YM}+F^3+F^4} = \int d^Dx \text{Tr} \left\{ \frac{1}{4} \mathbb{F}_{\mu\nu} \mathbb{F}^{\mu\nu} + \frac{2\alpha'}{3} \mathbb{F}_\mu{}^\nu \mathbb{F}_\nu{}^\lambda \mathbb{F}_\lambda{}^\mu + \frac{\alpha'^2}{4} [\mathbb{F}_{\mu\nu}, \mathbb{F}_{\lambda\rho}] [\mathbb{F}^{\mu\nu}, \mathbb{F}^{\lambda\rho}] \right\} \quad (3.1)$$

reproduce the leading orders α'^0, α'^1 in the low-energy expansion of bosonic-string amplitudes [80], and a well-defined sector of the α'^2 order: the effective action of both bosonic and supersymmetric open strings comprises an operator $\alpha'^2 \zeta_2 \text{Tr} F^4$ which can be cleanly distinguished from (3.1) by its transcendental prefactor $\zeta_2 = \frac{\pi^2}{6}$ [81–83]. Up to and including the order of α'^2 , the amplitudes computed from (3.1) obey BCJ relations (2.30) while the $\alpha'^2 \zeta_2 \text{Tr} F^4$ -operator excluded from (3.1) is incompatible with the BCJ duality [18]. As explained in the reference, these BCJ relations to the order of α'^2 rely on the interplay between single-insertions of the $\alpha'^2 \text{Tr} F^4$ -operator in (3.1) and double-insertions of $\alpha' \text{Tr} F^3$.

More generally, the accompanying multiple zeta values are instrumental to identify the $D^{2m} F^n$ -operators in string effective actions that admit color-kinematics dual representations. For instance, the entire single-trace gauge sector of the heterotic string obeys BCJ relations [20]. The subsector of open-bosonic-string amplitudes compatible with the BCJ duality was identified in [21], and the amplitude contributions without any zeta-value coefficient were derived from a field-theory Lagrangian [22].

The subsequent Berends-Giele recursions for the amplitudes of (3.1) follow a two-fold purpose: on the one hand, they will be used to generate economic and manifestly cyclic amplitude representations along the lines of section 2.3. On the other hand, they set the stage for

- an off-shell realization of the BCJ duality in section 4
- a kinematic proof of the BCJ relations in section 5.2
- a construction of manifestly local gauge-theory numerators subject to kinematic Jacobi relations in section 5.3.

All of these results hold to the order of α'^2 and are based on a non-linear gauge transformation of the generating series of Berends-Giele currents similar to (2.18).

3.1 Berends-Giele recursions for F^3 and F^4

Our Berends-Giele approach to (YM+ F^3 + F^4) follows the lines of section 2.2 to derive recursions for the currents from the non-linear equations of motion. The field variation of the action (3.1) is given by¹⁵

$$\frac{\delta \mathcal{S}_{\text{YM}+F^3+F^4}}{\delta \mathbb{A}_\lambda} = [\nabla_\mu, \mathbb{F}^{\lambda\mu}] + 2\alpha' [\nabla_\mu, [\mathbb{F}^{\mu\nu}, \mathbb{F}_\nu^\lambda]] + 2\alpha'^2 [\nabla_\mu, [[\mathbb{F}^{\mu\lambda}, \mathbb{F}_{\rho\sigma}], \mathbb{F}^{\rho\sigma}]] \quad (3.2)$$

and augments (2.11) by α' -corrections. In Lorenz gauge $\partial_\mu \mathbb{A}^\mu = 0$, setting (3.2) to zero amounts to a wave equation analogous to (2.13),

$$\begin{aligned} \square \mathbb{A}^\lambda &= [\mathbb{A}^\mu, \partial_\mu \mathbb{A}^\lambda] + [\mathbb{A}_\mu, \mathbb{F}^{\mu\lambda}] + 2\alpha' \{ [\nabla_\mu \mathbb{F}^{\mu\nu}, \mathbb{F}_\nu^\lambda] + [\mathbb{F}^{\mu\nu}, \nabla_\mu \mathbb{F}_\nu^\lambda] \} \\ &\quad + 2\alpha'^2 \{ [[\nabla_\mu \mathbb{F}^{\mu\lambda}, \mathbb{F}_{\rho\sigma}], \mathbb{F}^{\rho\sigma}] + [[\mathbb{F}^{\mu\lambda}, \nabla_\mu \mathbb{F}_{\rho\sigma}], \mathbb{F}^{\rho\sigma}] + [[\mathbb{F}^{\mu\lambda}, \mathbb{F}_{\rho\sigma}], \nabla_\mu \mathbb{F}^{\rho\sigma}] \}. \end{aligned} \quad (3.3)$$

¹⁵It is convenient to use $\frac{\delta}{\delta \mathbb{A}_\lambda} \text{Tr}(\mathbb{F}_{\mu\nu} X) = \delta_\mu^\lambda [\nabla_\nu, X] - \delta_\nu^\lambda [\nabla_\mu, X]$ in intermediate steps of deriving (3.2). The extensions of this lemma to $\mathbb{F}_{\mu\nu}$ -dependent quantities X follows straightforwardly from the Leibniz rule.

Since we will only be interested in the amplitude contributions up to the order of α'^2 , we can simplify (3.3) by dropping terms of order α'^3 and higher. At the first order in α' , this allows to replace $\nabla_\mu \mathbb{F}^{\mu\nu} = 2\alpha'[\mathbb{F}^{\rho\sigma}, \nabla_\rho \mathbb{F}_\sigma^\nu] + \mathcal{O}(\alpha'^2) = -\alpha'[\mathbb{F}^{\rho\sigma}, \nabla^\nu \mathbb{F}_{\rho\sigma}] + \mathcal{O}(\alpha'^2)$ such that

$$\square \mathbb{A}^\lambda = [\mathbb{A}^\mu, \partial_\mu \mathbb{A}^\lambda] + [\mathbb{A}_\mu, \mathbb{F}^{\mu\lambda}] + 2\alpha'[\mathbb{F}^{\mu\nu}, \nabla_\mu \mathbb{F}_\nu^\lambda] + 4\alpha'^2[[\mathbb{F}^{\mu\lambda}, \mathbb{F}^{\rho\sigma}], \nabla_\mu \mathbb{F}_{\rho\sigma}] + \mathcal{O}(\alpha'^3). \quad (3.4)$$

This form of the field equations gives rise to an efficient Berends-Giele recursion: we will study formal solutions of (3.4) modulo α'^3 that descend from a perturbative ansatz

$$\mathbb{A}^\mu = \sum_{P \neq \emptyset} A_P^\mu t^P e^{k_P \cdot x}, \quad \mathbb{F}^{\mu\nu} = \sum_{P \neq \emptyset} F_P^{\mu\nu} t^P e^{k_P \cdot x}, \quad (3.5)$$

where Lorenz gauge and the definition $\mathbb{F}^{\mu\nu} = -[\nabla^\mu, \nabla^\nu]$ of the field strength imply

$$k_P \cdot A_P = 0, \quad F_P^{\mu\nu} = k_P^\mu A_P^\nu - k_P^\nu A_P^\mu - \sum_{P=XY} (A_X^\mu A_Y^\nu - A_X^\nu A_Y^\mu). \quad (3.6)$$

In comparison to the perturbative (2.14) and (2.15) of undeformed YM theory, the Berends-Giele currents have been renamed as $J_P^\mu \rightarrow A_P^\mu$ and $B_P^{\mu\nu} \rightarrow F_P^{\mu\nu}$ in order to distinguish these α' -dependent quantities from the YM currents in (2.16) and (2.15),

$$J_P^\mu = \lim_{\alpha' \rightarrow 0} A_P^\mu, \quad B_P^{\mu\nu} = \lim_{\alpha' \rightarrow 0} F_P^{\mu\nu}. \quad (3.7)$$

In the same way as the Berends-Giele recursion of undeformed YM theory benefits from field-strength currents $B_P^{\mu\nu}$, the perturbative solutions to (3.4) are conveniently expressed in terms of the additional auxiliary currents

$$\nabla^\mu \mathbb{F}^{\nu\lambda} = \sum_{P \neq \emptyset} F_P^{\mu|\nu\lambda} t^P e^{k_P \cdot x}, \quad [\mathbb{F}^{\mu\nu}, \mathbb{F}^{\lambda\rho}] = \sum_{P \neq \emptyset} G_P^{\mu\nu|\lambda\rho} t^P e^{k_P \cdot x}. \quad (3.8)$$

By their definition in (3.8), the auxiliary currents are determined by A_P^μ and $F_P^{\mu\nu}$,

$$\begin{aligned} F_P^{\mu|\nu\lambda} &= k_P^\mu F_P^{\nu\lambda} - \sum_{P=XY} (A_X^\mu F_Y^{\nu\lambda} - A_Y^\mu F_X^{\nu\lambda}) \\ G_P^{\mu\nu|\lambda\rho} &= \sum_{P=XY} (F_X^{\mu\nu} F_Y^{\lambda\rho} - F_Y^{\mu\nu} F_X^{\lambda\rho}), \end{aligned} \quad (3.9)$$

in the same way as the $F_P^{\mu\nu}$ in (3.6) boil down to the elementary currents A_P^μ . All the above currents can be shown to obey shuffle symmetry

$$A_{P \sqcup Q}^\mu = F_{P \sqcup Q}^{\mu\nu} = F_{P \sqcup Q}^{\mu|\nu\lambda} = G_{P \sqcup Q}^{\mu\nu|\lambda\rho} = 0 \quad \forall P, Q \neq \emptyset \quad (3.10)$$

by repeating the arguments for the currents J_P^μ and $F_P^{\mu\nu}$ of pure YM theory [27, 65].

With the above definitions, the Berends-Giele recursion induced by the field equation (3.4) takes the simple form

$$\begin{aligned} A_i^\mu &= e_i^\mu \\ A_P^\mu &= \frac{1}{2s_P} \sum_{P=XY} \left[(k_Y \cdot A_X) A_Y^\mu + A_X^\nu F_Y^{\nu\mu} + 2\alpha' F_X^{\nu\lambda} F_Y^{\nu|\lambda\mu} + 4\alpha'^2 G_X^{\nu\mu|\rho\sigma} F_Y^{\nu|\rho\sigma} - (X \leftrightarrow Y) \right]. \end{aligned} \quad (3.11)$$

In analogy to (2.6), the leading orders $\alpha'^{\leq 2}$ of the tree amplitudes resulting from the action (3.1) are then given by

$$\mathcal{A}_{\text{YM}+F^3+F^4}(1, 2, \dots, n-1, n) = s_{12\dots n-1} A_{12\dots n-1}^\mu A_n^\mu + \mathcal{O}(\alpha'^3). \quad (3.12)$$

For instance, the rank-two current due to (3.11) with $X = 1$ and $Y = 2$ and the resulting three-point amplitude read

$$\begin{aligned} s_{12} A_{12}^\mu &= (k_2 \cdot e_1) e_2^\mu - (k_1 \cdot e_2) e_1^\mu + \frac{1}{2} (k_1^\mu - k_2^\mu) (e_1 \cdot e_2) \\ &+ \alpha' (k_1^\mu - k_2^\mu) [(k_1 \cdot k_2) (e_1 \cdot e_2) - (k_1 \cdot e_2) (k_2 \cdot e_1)] \end{aligned} \quad (3.13)$$

$$\mathcal{A}_{\text{YM}+F^3+F^4}(1, 2, 3) = [(k_2 \cdot e_1) (e_2 \cdot e_3) + \text{cyc}(1, 2, 3)] + 2\alpha' (k_2 \cdot e_1) (k_3 \cdot e_2) (k_1 \cdot e_3).$$

The last term of the three-point function illustrates a fundamental difference between the tensor structure of YM amplitudes and their F^3 corrections: contractions of the type $(k \cdot e)^n$ do not occur in n -point amplitudes of YM [84–86]. Hence, the expressions for $\mathcal{A}_{\text{YM}+F^3+F^4}$ in this work do not belong to the class of $D^{2m} F^n$ amplitudes that are accessible from the open superstring through a combination of color-ordered SYM trees [17].

By the shuffle symmetry (3.10) of the currents, the amplitude representation (3.12) can be used to demonstrate $\mathcal{A}_{\text{YM}+F^3+F^4}(1, 2, \dots, n)$ to also obey the Kleiss-Kuijf relations (2.9). The α'^1 -order of our results up to and including $n = 6$ points has been checked to match the D -dimensional CHY formulae of¹⁶ [26]. The $D = 4$ helicity components of the CHY expressions¹⁷ in turn have been verified to agree with the results of [88–90].

We emphasize that the form of the recursion in (3.11) only involves deconcatenations $P = XY$ into two words X, Y rather than three-word expressions with $P = XYZ$ as seen in (2.2). Hence, the amplitudes (3.12) naturally arise in a cubic-graph parametrization (2.27) as visualized in figure 7. The cubic-graph organization extends to the order of α'^2 , although each term of the $\text{Tr } F^4$ vertex in (3.1) involves at least four powers of the \mathbb{A}^μ field. Still, the quartic-vertex origin of the terms $G_X^{\nu\mu|\rho\sigma} F_Y^{\nu|\rho\sigma}$ in (3.11) is visible through the absence of single-particle currents $G_i^{\mu\nu|\lambda\rho} = 0$ since there is no deconcatenation $XY = i$ in (3.9). Like this, the part $G_X^{\nu\mu|\rho\sigma} F_Y^{\nu|\rho\sigma}$ of the recursion (3.11) can only contribute at minimum length $|X| + |Y| = 3$, i.e. to amplitudes (3.12) at multiplicity $n \geq 4$.

Note that the equation of motion (3.2) translates into the following expression for the tensor divergence of $F_P^{\mu\nu}$:

$$k_P^\lambda F_P^{\lambda\mu} = \sum_{P=XY} \left[A_X^\lambda F_Y^{\lambda\mu} + 2\alpha' F_X^{\nu\lambda} F_Y^{\nu|\lambda\mu} + 4\alpha'^2 G_X^{\nu\mu|\rho\sigma} F_Y^{\nu|\rho\sigma} - (X \leftrightarrow Y) \right] + \mathcal{O}(\alpha'^3). \quad (3.14)$$

3.2 Manifestly cyclic Berends-Giele representations

This section is dedicated to a reformulation of the Berends-Giele formula (3.12) for $\mathcal{A}_{\text{YM}+F^3+F^4}$ such as to manifest cyclicity and to reduce the maximum rank of the Berends-Giele constituents (3.11) on the right-hand side. This amounts to identifying a deformation

¹⁶We are grateful to Song He and Yong Zhang for providing the analytic expressions.

¹⁷See [87] for a systematic study of the reduction of CHY formulae to $D = 4$ dimensions.

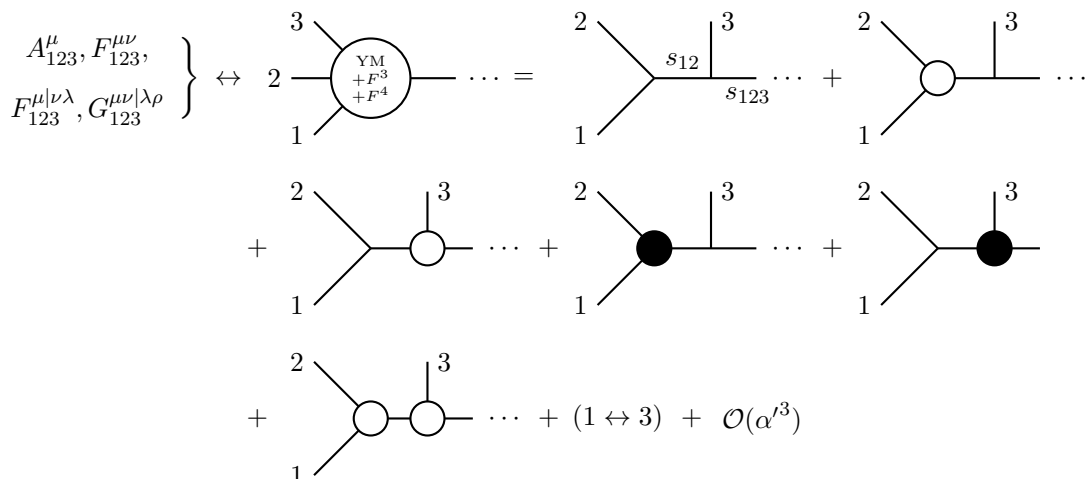

Figure 7. Berends-Giele currents $A_{12\dots p}^\mu, F_{12\dots p}^{\mu\nu}, F_{12\dots p}^{\mu|\nu\lambda}$ and $G_{12\dots p}^{\mu\nu|\lambda\rho}$ of rank p combine the diagrams and propagators expected in a color-ordered $(p+1)$ -point tree amplitude of $(\text{YM}+F^3+F^4)$ with an off-shell leg. . . . Vertices marked with a white and black dot represent the first and second order in α' on the right hand side of (3.11), i.e. the cubic-graph parametrization of $\alpha'F^3$ and α'^2F^4 insertions.

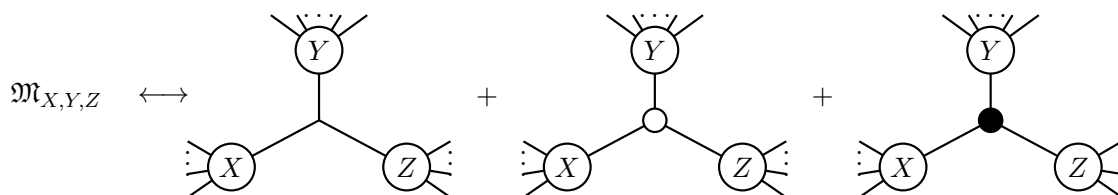

Figure 8. In the diagrammatic interpretation of the building block $\mathfrak{M}_{X,Y,Z}$ in (3.15), the central vertex can either be of YM type (first term), of $(\alpha'F^3)$ -type (white dot) or of (α'^2F^4) -type (black dot). The blobs labelled by X, Y, Z represent currents of $(\text{YM}+F^3+F^4)$.

of the cyclic $M_{X,Y,Z}$ building block in (2.20) that preserves the structure of the economic and manifestly cyclic amplitude representations (2.24) up to and including the order of α'^2 . The desired cyclic building block analogous to $M_{X,Y,Z}$ reads

$$\begin{aligned}
 \mathfrak{M}_{X,Y,Z} = & \frac{1}{2} (A_X^\mu F_Y^{\mu\nu} A_Z^\nu + \text{cyc}(X, Y, Z)) - 2\alpha' F_X^{\mu\nu} F_Y^{\nu\lambda} F_Z^{\lambda\mu} \\
 & + \left(\frac{\alpha'}{2} F_X^{\mu|\nu\lambda} F_Y^{\nu\lambda} A_Z^\mu + 2\alpha'^2 G_X^{\mu\nu|\lambda\rho} F_Y^{\mu|\lambda\rho} A_Z^\nu \pm \text{perm}(X, Y, Z) \right) \\
 & + \left(\frac{\alpha'^2}{2} G_X^{\mu\nu|\lambda\rho} F_Y^{\mu\nu} F_Z^{\lambda\rho} - 2\alpha'^2 F_X^{\mu\nu} F_Y^{\mu|\lambda\rho} F_Z^{\nu|\lambda\rho} + \text{cyc}(X, Y, Z) \right),
 \end{aligned} \tag{3.15}$$

where the notation $\pm\text{perm}(X, Y, Z)$ instructs to add five permutations with alternating signs and enforces permutation antisymmetry $\mathfrak{M}_{X,Y,Z} = -\mathfrak{M}_{Y,X,Z} = \mathfrak{M}_{Y,Z,X}$. The diagrammatic interpretation of the building block (3.15) can be found in figure 8.

In analogy with (2.21), the amplitude formula (3.12) can be rewritten as

$$\begin{aligned} \mathcal{A}_{\text{YM}+F^3+F^4}(1, 2, \dots, n-1, n) &= \sum_{XY=12\dots n-1} \mathfrak{M}_{X,Y,n} + \mathcal{O}(\alpha'^3) \\ &= \sum_{j=1}^{n-2} \mathfrak{M}_{12\dots j, j+1\dots n-1, n} + \mathcal{O}(\alpha'^3). \end{aligned} \quad (3.16)$$

To first order in α' , the equivalence with (3.12) is proven to all multiplicities in appendix A.1. At second order in α'^2 , (3.16) has been checked analytically to multiplicity $n = 6$ and numerically up to and including $n = 8$. In the same way as we are only interested in the orders $\alpha'^{\leq 2}$ of the amplitudes (3.16), we will consistently drop terms at the orders $\alpha'^{\geq 3}$ in later equations of this work and skip the disclaimer $\mathcal{O}(\alpha'^3)$ for ease of notation.

Amplitude representations with manifest cyclicity and lower-rank Berends-Giele currents can be obtained by an integration-by-parts property that takes the same form as (2.22),

$$\sum_{XY=A} \mathfrak{M}_{X,Y,B} = \sum_{XY=B} \mathfrak{M}_{A,X,Y}, \quad (3.17)$$

starting with $\mathfrak{M}_{12,3,4} = \mathfrak{M}_{1,2,3,4}$, see (2.23) for higher-point examples. At the order of α' , a general proof of (3.17) can be found in appendix A.2. At the order of α'^2 , (3.17) has been checked analytically at $|A| + |B| \leq 6$ as well as numerically at $|A| + |B| \leq 8$ and is conjectural at higher multiplicity.

By applying (3.17) to the amplitude representation (3.16), one gets manifestly cyclic expressions analogous to (2.24),

$$\begin{aligned} \mathcal{A}_{\text{YM}+F^3+F^4}(1, 2, 3, 4) &= \frac{1}{2} \mathfrak{M}_{12,3,4} + \text{cyc}(1, 2, 3, 4) \\ \mathcal{A}_{\text{YM}+F^3+F^4}(1, 2, \dots, 5) &= \mathfrak{M}_{12,3,4,5} + \text{cyc}(1, 2, 3, 4, 5) \\ \mathcal{A}_{\text{YM}+F^3+F^4}(1, 2, \dots, 6) &= \frac{1}{3} \mathfrak{M}_{12,3,4,5,6} + \frac{1}{2} (\mathfrak{M}_{123,4,5,6} + \mathfrak{M}_{123,4,5,6}) + \text{cyc}(1, 2, \dots, 6) \\ \mathcal{A}_{\text{YM}+F^3+F^4}(1, 2, \dots, 7) &= \mathfrak{M}_{123,4,5,6,7} + \mathfrak{M}_{1,234,5,6,7} + \text{cyc}(1, 2, \dots, 7), \end{aligned} \quad (3.18)$$

as well as

$$\begin{aligned} \mathcal{A}_{\text{YM}+F^3+F^4}(1, 2, \dots, 8) &= \frac{1}{2} (\mathfrak{M}_{1234,5,6,7,8} + \mathfrak{M}_{1234,5,6,7,8} + \mathfrak{M}_{1234,5,6,7,8}) \\ &\quad + \mathfrak{M}_{123,4,5,6,7,8} + \text{cyc}(1, 2, \dots, 8) \\ \mathcal{A}_{\text{YM}+F^3+F^4}(1, 2, \dots, 9) &= \mathfrak{M}_{1234,5,6,7,8,9} + \mathfrak{M}_{1234,5,6,7,8,9} + \mathfrak{M}_{1234,5,6,7,8,9} \\ &\quad + \frac{1}{3} \mathfrak{M}_{123,4,5,6,7,8,9} + \text{cyc}(1, 2, \dots, 9) \\ \mathcal{A}_{\text{YM}+F^3+F^4}(1, 2, \dots, 0) &= \frac{1}{2} (\mathfrak{M}_{12345,6,7,8,9,0} + \mathfrak{M}_{12345,6,7,8,9,0} + \mathfrak{M}_{12345,6,7,8,9,0} + \mathfrak{M}_{12345,6,7,8,9,0}) \\ &\quad + \mathfrak{M}_{1234,5,6,7,8,9,0} + \mathfrak{M}_{1234,5,6,7,8,9,0} + \text{cyc}(1, 2, \dots, 0). \end{aligned} \quad (3.19)$$

The rational prefactors of non-prime multiplicities $n = 4, 6, 8, 9$ avoid overcounting of cubic diagrams when combinations of currents are invariant under less than n cyclic shifts $i \rightarrow i+1$. Integration by parts (3.17) can be used to bypass such prefactors in expressions like

$$\begin{aligned} \mathcal{A}_{\text{YM}+F^3+F^4}(1, 2, 3, 4) &= \mathfrak{M}_{12,3,4} + \mathfrak{M}_{23,4,1} \\ \mathcal{A}_{\text{YM}+F^3+F^4}(1, 2, \dots, 6) &= \mathfrak{M}_{12,34,56} + \mathfrak{M}_{23,45,61} + \mathfrak{M}_{123,45,6} + \mathfrak{M}_{123,4,56} \\ &\quad + \mathfrak{M}_{234,56,1} + \mathfrak{M}_{234,5,61} + \mathfrak{M}_{345,61,2} + \mathfrak{M}_{345,6,12}, \end{aligned} \quad (3.20)$$

also see [28, 37, 38] for the antecedents of these representations in ten-dimensional SYM. Similarly, the all-multiplicity series of cyclic representations

$$\mathcal{A}_{\text{YM}+F^3+F^4}(1, 2, \dots, n) = \frac{1}{2(n-3)} \sum_{j=2}^{n-2} \sum_{l=j+1}^{n-1} \mathfrak{M}_{12\dots j, j+1\dots l, l+1\dots n} + \text{cyc}(1, 2, \dots, n) \quad (3.21)$$

can be imported from ten-dimensional SYM [17].

3.3 Gauge algebra of $F^3 + F^4$ building blocks

The action of non-linear gauge transformations $\delta_\Omega \mathbb{A}^\mu = \partial^\mu \Omega - [\mathbb{A}^\mu, \Omega]$ is not altered by the higher-mass-dimension operators in the action (3.1). Hence, given perturbiner components Ω_P for the gauge scalars Ω , the α' -deformed currents of the previous subsection follow the transformations of the YM currents (2.18),

$$\begin{aligned} \delta_\Omega A_P^\mu &= k_P^\mu \Omega_P - \sum_{XY=P} (A_X^\mu \Omega_Y - A_Y^\mu \Omega_X), & \delta_\Omega F_P^{\mu\nu} &= - \sum_{XY=P} (F_X^{\mu\nu} \Omega_Y - F_Y^{\mu\nu} \Omega_X) \\ \delta_\Omega F_P^{\mu|\nu\lambda} &= - \sum_{XY=P} (F_X^{\mu|\nu\lambda} \Omega_Y - F_Y^{\mu|\nu\lambda} \Omega_X), & \delta_\Omega G_P^{\mu\nu|\lambda\rho} &= - \sum_{XY=P} (G_X^{\mu\nu|\lambda\rho} \Omega_Y - G_Y^{\mu\nu|\lambda\rho} \Omega_X). \end{aligned} \quad (3.22)$$

One can therefore verify non-linear gauge invariance of the amplitude formula (3.12) by repeating the arguments of the undeformed gauge theory: among the three terms in the gauge variation

$$\begin{aligned} \delta_\Omega (s_{12\dots n-1} A_{12\dots n-1} \cdot A_n) &= s_{12\dots n-1} \left\{ (A_{12\dots n-1} \cdot k_n) \Omega_n + \Omega_{12\dots n-1} (k_{12\dots n-1} \cdot A_n) \right. \\ &\quad \left. + \sum_{12\dots n-1=XY} (\Omega_Y A_X^\mu - \Omega_X A_Y^\mu) A_n^\mu \right\}, \end{aligned} \quad (3.23)$$

the first one vanishes by the Lorenz-gauge condition $k_{12\dots n-1} \cdot A_{12\dots n-1} = 0$ and the second one due to transversality $k_n \cdot A_n = 0$ (using momentum conservation $k_{12\dots n-1}^\mu = -k_n^\mu$ in both cases). The currents in the second line of (3.23) have multiplicity $|X|, |Y| \leq n-2$ and are therefore regular as $s_{12\dots n-1} \rightarrow 0$, so multiplication with $s_{12\dots n-1}$ causes this term to vanish as well. This rests on the reasonable assumption that the gauge scalars Ω_P descend from a perturbiner and can only have poles in s_Q for subsets $Q \subseteq P$.

By the Leibniz property of δ_Ω , momentum conservation and the expression (3.14) for contractions of the form $k_P^\mu F_P^{\mu\nu}$, one can infer the non-linear gauge transformation of the

building blocks (3.15). The result is most conveniently expressed in terms of a scalar quantity $\Omega_{X,Y,Z,W} = \Omega_{[X,Y,Z,W]}$ which is totally antisymmetric in four multiparticle labels X, Y, Z, W ,

$$\begin{aligned} \delta_\Omega \mathfrak{M}_{X,Y,Z} &= \sum_{X=PQ} \Omega_{P,Q,Y,Z} + \sum_{Y=PQ} \Omega_{P,Q,Z,X} + \sum_{Z=PQ} \Omega_{P,Q,X,Y} \quad (3.24) \\ \Omega_{X,Y,Z,W} &= \Omega_X \mathfrak{M}_{Y,Z,W} - \Omega_Y \mathfrak{M}_{Z,W,X} + \Omega_Z \mathfrak{M}_{W,X,Y} - \Omega_W \mathfrak{M}_{X,Y,Z}. \end{aligned}$$

While the $\alpha' \rightarrow 0$ limit of (3.24) descends from BRST variations of superspace building blocks in ten-dimensional SYM theory [28], a proof to the first order in α' is given in appendix A.3. At the order of α'^2 , we have tested (3.24) to the order of $|X| + |Y| + |Z| = 6$.

Based on the gauge algebra (3.24) and permutation antisymmetry $\Omega_{X,Y,Z,W} = \Omega_{[X,Y,Z,W]}$, one can check the non-linear gauge invariance of the manifestly cyclic amplitude representations in (3.18), (3.19) and (3.21). In particular, this will be exploited in later sections to evaluate the $\mathfrak{M}_{X,Y,Z}$ in BCJ gauge which is tailored to manifest the BCJ duality via local numerators.

4 Kinematic Jacobi identities in off-shell diagrams

The purpose of this section is to manifest the BCJ duality between color and kinematics in off-shell diagrams of $(YM + F^3 + F^4)$. We will construct local solutions to the kinematic Jacobi relations (2.29) in the subdiagram with an off-shell leg drawn in figure 9. This amounts to assigning kinematic numerators to the cubic-vertex diagram in the figure which share the symmetries of the associated color factors

$$C_{123\dots p}^b = f^{a_1 a_2 c} f^{c a_3 d} f^{d a_4 e} \dots f^{y a_{p-1} z} f^{z a_p b}. \quad (4.1)$$

The adjoint indices a_1, a_2, \dots, a_p refer to p on-shell legs, and an off-shell leg is associated with a free adjoint index b carried by the rightmost factor in (4.1).

When identifying the dotted off-shell line in figure 9 with an external on-shell leg, we recover the half-ladder diagrams of figure 6 that define the master numerators at $n = p+1$ points. Accordingly, permutations of figure 9 in $2, 3, \dots, p$ will be associated with the master numerators in an off-shell setup: cubic diagrams which are not of half-ladder form or do not have leg 1 and the off-shell leg... at their endpoints can be reached from $(p-1)!$ permutations of figure 9 through a sequence of Jacobi identities.

In specific examples of (4.1) at rank $p \leq 5$, antisymmetry $f^{a_i a_j a_k} = f^{[a_i a_j a_k]}$ and Jacobi identities (2.25) imply the so-called *Lie symmetries* for the color factors,

$$\begin{aligned} 0 &= C_{12\dots}^b + C_{21\dots}^b, & 0 &= C_{123\dots}^b + C_{231\dots}^b + C_{312\dots}^b \\ 0 &= C_{1234\dots}^b - C_{1243\dots}^b + C_{3412\dots}^b - C_{3421\dots}^b & (4.2) \\ 0 &= C_{12345\dots}^b - C_{12354\dots}^b - C_{12453\dots}^b + C_{12543\dots}^b + C_{45321\dots}^b - C_{45312\dots}^b. \end{aligned}$$

The ellipsis in the subscript of each term indicates that lower-rank symmetries in the first labels extend to higher rank. For instance, $C_{12}^b = f^{a_1 a_2 b} = -f^{a_2 a_1 b} = -C_{21}^b$ can be shown

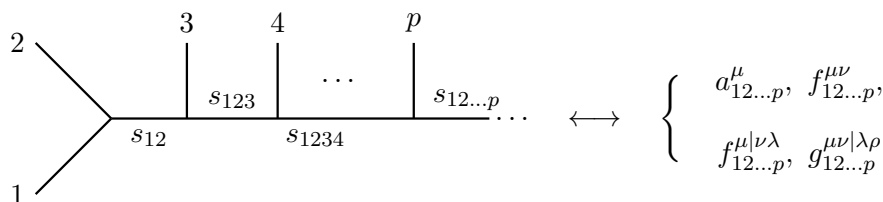

Figure 9. This section is dedicated to constructing local and Jacobi-satisfying kinematic representatives for the depicted cubic diagram of $(YM+F^3+F^4)$. The notation $a_{12\dots p}^\mu$, $f_{12\dots p}^{\mu\nu}$, $f_{12\dots p}^{\mu|\nu\lambda}$ and $g_{12\dots p}^{\mu\nu|\lambda\rho}$ will be introduced in subsection 4.1 and refers to four types of such solutions at different mass dimensions.

to persist at any rank $p > 2$ by contraction with $f^{ba_3c} f^{ca_4d} \dots f^{xa_{p-1}y} f^{ya_pz}$ which yields $C_{123\dots p}^z = -C_{213\dots p}^z$. The generalization of the Lie symmetries (4.2) to higher rank will be spelt out in (4.28) and can be checked to leave $(p-1)!$ independent permutations of $C_{123\dots p}^b$ at rank p .

We will now describe the construction of local kinematic factors for $(YM+F^3+F^4)$ with the same Lie symmetries of (4.2) which imply kinematic Jacobi relations. The recursive procedure presented in this section closely follows the steps of [15], where local superspace building blocks with Lie symmetries have been constructed for ten-dimensional SYM.

4.1 Local multiparticle polarizations up to rank three

As we already saw for the Berends-Giele currents of the previous section, each cubic vertex of $(YM+F^3+F^4)$ may introduce powers of α'^0 , α'^1 or α'^2 into the kinematic factors. We no longer distinguish these contributions from the individual vertices (as done by the white and black circles in figure 7 and 8) and collectively refer to all contributions at orders $\alpha'^{\leq 2}$ through the off-shell diagram in figure 9. We will start from the numerators in the Berends-Giele recursion (3.11) to construct solutions to the kinematic Jacobi identities — i.e. realizations of the Lie symmetries in (4.2) — up to the order of α'^2 .

Kinematic representatives for the diagram in figure 9 with Lie symmetries will be referred to as *multiparticle polarizations* and denoted by lowercase parental letters $a_{12\dots p}^\mu$, $f_{12\dots p}^{\mu\nu}$, $f_{12\dots p}^{\mu|\nu\lambda}$ and $g_{12\dots p}^{\mu\nu|\lambda\rho}$. This notation will help to distinguish the local multiparticle polarizations from the Berends-Giele currents A_P^μ , $F_P^{\mu\nu}$, $F_P^{\mu|\nu\lambda}$ and $G_P^{\mu\nu|\lambda\rho}$ with kinematic poles. In the same way as all the four species of Berends-Giele currents enter the cyclic building block $\mathfrak{M}_{X,Y,Z}$ in (3.15), we will later on see that the analogous four species of multiparticle polarizations can be combined to Jacobi-satisfying kinematic numerators N_I in the sense of section 2.4.

At rank one, the local multiparticle polarizations are defined to match their Berends-Giele counterparts which include the transverse polarization vectors e_i^μ and do not exhibit any kinematic poles,

$$\begin{aligned}
 a_i^\mu &= e_i^\mu = A_i^\mu, & f_i^{\mu\nu} &= k_i^\mu e_i^\nu - k_i^\nu e_i^\mu = F_i^{\mu\nu} \\
 f_i^{\mu|\nu\lambda} &= k_i^\mu f_i^{\nu\lambda} = F_i^{\mu|\nu\lambda}, & g_i^{\mu\nu|\lambda\rho} &= 0 = G_i^{\mu\nu|\lambda\rho}.
 \end{aligned}
 \tag{4.3}$$

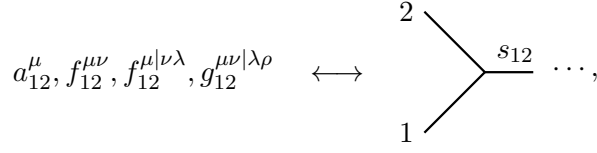

Figure 10. Diagrammatic interpretation of two-particle polarizations $a_{12}^\mu, f_{12}^{\mu\nu}, f_{12}^{\mu|\nu\lambda}, g_{12}^{\mu\nu|\lambda\rho}$.

The simplest multiparticle polarization a_{12}^μ at rank two is defined by isolating the numerator in the Berends-Giele current (3.13),

$$a_{12}^\mu = \frac{1}{2} \left[(k_2 \cdot a_1) a_2^\mu - (k_1 \cdot a_2) a_1^\mu + a_1^\nu f_2^{\nu\mu} - a_2^\nu f_1^{\nu\mu} + 2\alpha' (f_1^{\nu\lambda} f_2^{\nu|\lambda\mu} - f_2^{\nu\lambda} f_1^{\nu|\lambda\mu}) \right], \quad (4.4)$$

where the absence of contributions at order α'^2 is plausible by the valence of the Feynman vertices from $\alpha'^2 F^4$. The alternative presentation of (4.4) as $a_{12}^\mu = s_{12} A_{12}^\mu$ generalizes to the following two-particle polarizations at higher mass dimension,

$$\begin{aligned} f_{12}^{\mu\nu} &= k_{12}^\mu a_{12}^\nu - k_{12}^\nu a_{12}^\mu - (k_1 \cdot k_2) (a_1^\mu a_2^\nu - a_1^\nu a_2^\mu) = s_{12} F_{12}^{\mu\nu} \\ f_{12}^{\mu|\nu\lambda} &= k_{12}^\mu f_{12}^{\nu\lambda} - (k_1 \cdot k_2) (a_1^\mu f_2^{\nu\lambda} - a_2^\mu f_1^{\nu\lambda}) = s_{12} F_{12}^{\mu|\nu\lambda} \\ g_{12}^{\mu\nu|\lambda\rho} &= (k_1 \cdot k_2) (f_1^{\mu\nu} f_2^{\lambda\rho} - f_2^{\mu\nu} f_1^{\lambda\rho}) = s_{12} G_{12}^{\mu\nu|\lambda\rho}. \end{aligned} \quad (4.5)$$

The local multiparticle polarizations are still proportional to their Berends-Giele counterparts since the latter only describe a single cubic diagram, see figure 10. By the shuffle symmetry $A_{12}^\mu = -A_{21}^\mu$ of Berends-Giele currents or the antisymmetry $C_{12}^b = -C_{21}^b$ of the dual color factors (4.1), we have

$$a_{12}^\mu = -a_{21}^\mu, \quad f_{12}^{\mu\nu} = -f_{21}^{\mu\nu}, \quad f_{12}^{\mu|\nu\lambda} = -f_{21}^{\mu|\nu\lambda}, \quad g_{12}^{\mu\nu|\lambda\rho} = -g_{21}^{\mu\nu|\lambda\rho}. \quad (4.6)$$

Starting from rank three, Berends-Giele currents involve multiple cubic diagrams. Multiparticle polarizations for the individual diagrams can be built by isolating one of the two deconcatenations $(X, Y) = (12, 3)$ and $(X, Y) = (1, 23)$ in (3.11) that contribute to A_{123}^μ . The numerator w.r.t. $s_{12}^{-1} s_{123}^{-1}$ stems from $(X, Y) = (12, 3)$ and reads

$$\begin{aligned} \widehat{a}_{123}^\mu &= \frac{1}{2} \left[(k_3 \cdot a_{12}) a_3^\mu - (k_{12} \cdot a_3) a_{12}^\mu + a_{12}^\nu f_3^{\nu\mu} - a_3^\nu f_{12}^{\nu\mu} \right. \\ &\quad \left. + 2\alpha' (f_{12}^{\nu\lambda} f_3^{\nu|\lambda\mu} - f_3^{\nu\lambda} f_{12}^{\nu|\lambda\mu}) + 4\alpha'^2 g_{12}^{\nu\mu|\rho\sigma} f_3^{\nu|\rho\sigma} \right], \end{aligned} \quad (4.7)$$

where a formal antisymmetry under exchange of labels $12 \leftrightarrow 3$ can be manifested by adding $0 = -2\alpha'^2 g_3^{\nu\mu|\rho\sigma} f_{12}^{\nu|\rho\sigma}$. The Berends-Giele numerator \widehat{a}_{123}^μ should ideally share the symmetries (4.2) of the color factor C_{123}^b . Indeed, antisymmetry $\widehat{a}_{123}^\mu = -\widehat{a}_{213}^\mu$ in the first two indices is inherited from the property (4.6) of the rank-two input. However, the first non-trivial kinematic Jacobi identity for the triplet of cubic diagrams in figure 11 requires $\widehat{a}_{123}^\mu + \widehat{a}_{231}^\mu + \widehat{a}_{312}^\mu$ to vanish, which is not the case. Still, the obstruction takes a special form, where one can factor out the overall momentum k_{123}^μ and isolate a scalar quantity h_{123} that captures the deviation from the Lie symmetries

$$\widehat{a}_{123}^\mu + \widehat{a}_{231}^\mu + \widehat{a}_{312}^\mu = 3k_{123}^\mu h_{123}. \quad (4.8)$$

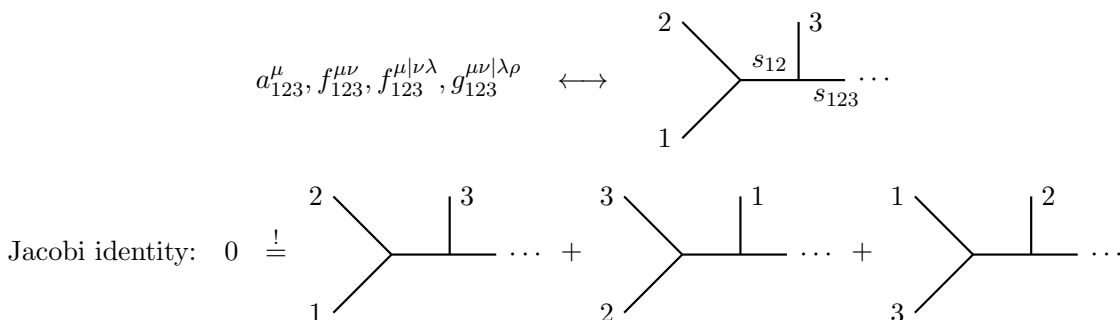

Figure 11. Diagrammatic interpretation of three-particle polarizations $a_{123}^\mu, f_{123}^{\mu\nu}, f_{123}^{\mu|\nu\lambda}$, and $g_{123}^{\mu\nu|\lambda\rho}$ subject to kinematic Jacobi relations such as $a_{123}^\mu + \text{cyc}(1, 2, 3) = 0$.

Amusingly, the explicit form of

$$\begin{aligned}
 6h_{123} &= \left(\frac{1}{2} a_1^\mu f_2^{\mu\nu} a_3^\nu - 2\alpha'^2 f_1^{\mu\nu} f_2^{\mu|\lambda\rho} f_3^{\nu|\lambda\rho} + \text{cyc}(1, 2, 3) \right) \\
 &\quad - 2\alpha' f_1^{\mu\nu} f_2^{\nu\lambda} f_3^{\lambda\mu} + \frac{\alpha'}{2} (f_1^{\mu|\nu\lambda} f_2^{\nu\lambda} a_3^\mu \pm \text{perm}(1, 2, 3)) \\
 &= \mathfrak{M}_{1,2,3}
 \end{aligned} \tag{4.9}$$

can be reproduced from the cyclic building block of (3.15). Already the left-hand side of (4.8) implies permutation-antisymmetry $h_{123} = h_{[123]}$, so a redefinition of the Berends-Giele numerator (4.7) via

$$a_{123}^\mu = \widehat{a}_{123}^\mu - k_{123}^\mu h_{123} \tag{4.10}$$

yields the desired Lie symmetries of the color factors,

$$a_{123}^\mu = -a_{213}^\mu, \quad a_{123}^\mu + a_{231}^\mu + a_{312}^\mu = 0. \tag{4.11}$$

As we will see, the appearance of the overall momentum k_{123}^μ in the correction (4.10) to \widehat{a}_{123}^μ is essential to absorb the analogous improvements of Berends-Giele currents into a non-linear gauge transformation (3.22).

Given a multiparticle polarization $a_{12\dots p}^\mu$ at rank p , the construction of its analogues $f_{12\dots p}^{\mu\nu}, f_{12\dots p}^{\mu|\nu\lambda}$ and $g_{12\dots p}^{\mu\nu|\lambda\rho}$ at higher mass dimension involves contact terms $\sim s_{ij}$ that preserve the Lie symmetries. For instance, the rank-three generalizations of (4.5)

$$\begin{aligned}
 f_{123}^{\mu\nu} &= k_{123}^\mu a_{123}^\nu - (k_{12} \cdot k_3) a_{12}^\mu a_3^\nu - (k_1 \cdot k_2) (a_1^\mu a_{23}^\nu - a_2^\mu a_{13}^\nu) - (\mu \leftrightarrow \nu) \\
 f_{123}^{\mu|\nu\lambda} &= k_{123}^\mu f_{123}^{\nu\lambda} - (k_{12} \cdot k_3) (a_{12}^\mu f_3^{\nu\lambda} - f_{12}^{\nu\lambda} a_3^\mu) \\
 &\quad - (k_1 \cdot k_2) (a_1^\mu f_{23}^{\nu\lambda} - a_{23}^\mu f_1^{\nu\lambda} - a_2^\mu f_{13}^{\nu\lambda} + a_{13}^\mu f_2^{\nu\lambda}) \\
 g_{123}^{\mu\nu|\lambda\rho} &= (k_{12} \cdot k_3) (f_{12}^{\mu\nu} f_3^{\lambda\rho} - f_{12}^{\lambda\rho} f_3^{\mu\nu}) + (k_1 \cdot k_2) (f_1^{\mu\nu} f_{23}^{\lambda\rho} - f_{23}^{\mu\nu} f_1^{\lambda\rho} - f_2^{\mu\nu} f_{13}^{\lambda\rho} + f_{13}^{\mu\nu} f_2^{\lambda\rho})
 \end{aligned} \tag{4.12}$$

are easily checked to reproduce the symmetries (4.11) of a_{123}^μ . These contact terms are the local equivalents of the deconcatenation terms in the Berends-Giele currents $F_P^{\mu\nu}, F_P^{\mu|\nu\lambda}$ and $G_P^{\mu\nu|\lambda\rho}$ in (3.6) and (3.9), see section 5.1 for more details and [15] for superspace analogues.

While the difference between a_{123}^μ and \widehat{a}_{123}^μ in (4.10) drops out from the definition (4.12) of $f_{123}^{\mu\nu}$, it will be crucial at higher rank to always build $f_{12\dots p}^{\mu\nu}$, $f_{12\dots p}^{\mu|\nu\lambda}$ and $g_{12\dots p}^{\mu\nu|\lambda\rho}$ from the redefined fields subject to Lie symmetries.

4.2 Local multiparticle polarizations at rank four and five

The numerators of the Berends-Giele recursion (3.11) serve as a starting point to construct higher-rank multiparticle polarizations for the diagrams in figure 9 that satisfy the Lie symmetries (4.2) of the dual color factors. The higher-rank systematics of the redefinition in (4.10) is most conveniently illustrated via examples at $p = 4, 5$.

Given the multiparticle polarizations at rank three in (4.10) and (4.12), their Lie symmetries imply that the rank-four object

$$\begin{aligned} \widehat{a}_{1234}^\mu &= \frac{1}{2} \left[(k_4 \cdot a_{123}) a_4^\mu - (k_{123} \cdot a_4) a_{123}^\mu + a_{123}^\nu f_4^{\nu\mu} - a_4^\nu f_{123}^{\nu\mu} \right. \\ &\quad \left. + 2\alpha' (f_{123}^{\nu\lambda} f_4^{\nu|\lambda\mu} - f_4^{\nu\lambda} f_{123}^{\nu|\lambda\mu}) + 4\alpha'^2 g_{123}^{\nu\mu|\rho\sigma} f_4^{\nu|\rho\sigma} \right] \end{aligned} \quad (4.13)$$

obeys $\widehat{a}_{1234}^\mu = -\widehat{a}_{2134}^\mu$ and $\widehat{a}_{1234}^\mu + \widehat{a}_{2314}^\mu + \widehat{a}_{3124}^\mu = 0$. However, the Lie symmetry at rank four is not yet satisfied by (4.13), and in contrast to (4.8), it is *not* possible to factorize k_{1234}^μ from $\widehat{a}_{1234}^\mu - \widehat{a}_{1243}^\mu + \widehat{a}_{3412}^\mu - \widehat{a}_{3421}^\mu$. Instead, we will need redefinitions $\widehat{a}_{1234}^\mu \rightarrow a'_{1234}^\mu \rightarrow a_{1234}^\mu$ in two steps, where an intermediate object a'_{1234}^μ is built from permutations of the scalar h_{ijk} in the rank-three redefinition, see (4.9),

$$a'_{1234}^\mu = \widehat{a}_{1234}^\mu - (k_{12} \cdot k_3) a_3^\mu h_{124} - (k_1 \cdot k_2) (a_2^\mu h_{134} - a_1^\mu h_{234}). \quad (4.14)$$

The pattern of subtractions in (4.14) has been inferred by mimicking BRST transformations in ten-dimensional pure-spinor superspace [15], and it should be possible to give a similar motivation from a study of linearized gauge variations. The key benefit of the redefinition in (4.14) is that the deviation from the rank-four Lie symmetry now takes a factorized form

$$a'_{1234}^\mu - a'_{1243}^\mu + a'_{3412}^\mu - a'_{3421}^\mu = 4k_{1234}^\mu h_{1234}, \quad (4.15)$$

see (4.25) for convenient representations of the scalar h_{1234} . The left-hand side of (4.15) along with $a'_{1234}^\mu = -a'_{2134}^\mu$ and $a'_{1234}^\mu + a'_{2314}^\mu + a'_{3124}^\mu = 0$ imply the symmetries $h_{1234} = -h_{2134} = h_{3412} = -h_{3421}$ and $h_{1234} + h_{2314} + h_{3124} = 0$. Like this, the redefinition

$$a_{1234}^\mu = a'_{1234}^\mu - k_{1234}^\mu h_{1234} \quad (4.16)$$

leads to the desired Lie symmetries

$$a_{1234}^\mu = -a_{2134}^\mu, \quad a_{1234}^\mu + a_{2314}^\mu + a_{3124}^\mu = 0, \quad a_{1234}^\mu - a_{1243}^\mu + a_{3412}^\mu - a_{3421}^\mu = 0. \quad (4.17)$$

This final form of the multiparticle polarization a_{1234}^μ can be used to construct its counterparts at higher mass dimensions, where the Lie-symmetry preserving contact terms

in (4.12) generalize to¹⁸

$$\begin{aligned}
 f_{1234}^{\mu\nu} &= k_{1234}^\mu a_{1234}^\nu - (k_{123} \cdot k_4) a_{123}^\mu a_4^\nu - (k_{12} \cdot k_3) (a_{12}^\mu a_{34}^\nu + a_{124}^\mu a_3^\nu) \\
 &\quad - (k_1 \cdot k_2) (a_{13}^\mu a_{24}^\nu + a_{14}^\mu a_{23}^\nu + a_{134}^\mu a_2^\nu - a_{234}^\mu a_1^\nu) - (\mu \leftrightarrow \nu) \\
 f_{1234}^{\mu|\nu\lambda} &= k_{1234}^\mu f_{1234}^{\nu\lambda} - [(k_{123} \cdot k_4) a_{123}^\mu f_4^{\nu\lambda} + (k_{12} \cdot k_3) (a_{12}^\mu f_{34}^{\nu\lambda} + a_{124}^\mu f_3^{\nu\lambda}) \\
 &\quad + (k_1 \cdot k_2) (a_{13}^\mu f_{24}^{\nu\lambda} + a_{14}^\mu f_{23}^{\nu\lambda} + a_{134}^\mu f_2^{\nu\lambda} - a_{234}^\mu f_1^{\nu\lambda}) - (a_P^\mu f_Q^{\nu\lambda} \leftrightarrow a_Q^\mu f_P^{\nu\lambda})] \\
 g_{1234}^{\mu\nu|\lambda\rho} &= (k_{123} \cdot k_4) f_{123}^{\mu\nu} f_4^{\lambda\rho} + (k_{12} \cdot k_3) (f_{12}^{\mu\nu} f_{34}^{\lambda\rho} + f_{124}^{\mu\nu} f_3^{\lambda\rho}) \\
 &\quad + (k_1 \cdot k_2) (f_{13}^{\mu\nu} f_{24}^{\lambda\rho} + f_{14}^{\mu\nu} f_{23}^{\lambda\rho} + f_{134}^{\mu\nu} f_2^{\lambda\rho} - f_{234}^{\mu\nu} f_1^{\lambda\rho}) - (f_P^{\mu\nu} f_Q^{\lambda\rho} \leftrightarrow f_Q^{\mu\nu} f_P^{\lambda\rho}).
 \end{aligned} \tag{4.18}$$

At higher rank, analogous redefinitions in two steps $\widehat{a}_{123\dots p}^\mu \rightarrow a_{123\dots p}^{\prime\mu} \rightarrow a_{123\dots p}^\mu$ will be sufficient to attain Lie symmetries, i.e. there are no additional intermediate steps at $p > 4$. For instance, the Lie-symmetry satisfying multiparticle polarizations (4.16) and (4.18) at rank four can be used to recursively construct a rank-five quantity

$$\begin{aligned}
 \widehat{a}_{12345}^\mu &= \frac{1}{2} \left[(k_5 \cdot a_{1234}) a_5^\mu - (k_{1234} \cdot a_5) a_{1234}^\mu + a_{1234}^\nu f_5^{\nu\mu} - a_5^\nu f_{1234}^{\nu\mu} \right. \\
 &\quad \left. + 2\alpha' (f_{1234}^{\nu\lambda} f_5^{\nu|\lambda\mu} - f_5^{\nu\lambda} f_{1234}^{\nu|\lambda\mu}) + 4\alpha'^2 g_{1234}^{\nu\mu|\rho\sigma} f_5^{\nu|\rho\sigma} \right]
 \end{aligned} \tag{4.19}$$

subject to the symmetries (4.17) in its first four labels. The rank-five Lie symmetry can be enforced by first performing subtractions analogous to (4.14) and [15],

$$\begin{aligned}
 a_{12345}^{\prime\mu} &= \widehat{a}_{12345}^\mu - (k_{123} \cdot k_4) a_4^\mu h_{1235} - (k_{12} \cdot k_3) (a_3^\mu h_{1245} + a_{34}^\mu h_{125} - a_{12}^\mu h_{345}) \\
 &\quad - (k_1 \cdot k_2) (a_2^\mu h_{1345} + a_{23}^\mu h_{145} + a_{24}^\mu h_{135} - a_1^\mu h_{2345} - a_{13}^\mu h_{245} - a_{14}^\mu h_{235}),
 \end{aligned} \tag{4.20}$$

and then identifying a rank-five scalar h_{12345} along the lines of (4.15),

$$a_{12345}^{\prime\mu} - a_{12354}^{\prime\mu} + a_{45123}^{\prime\mu} - a_{45213}^{\prime\mu} - a_{45312}^{\prime\mu} + a_{45321}^{\prime\mu} = 5k_{12345}^\mu h_{12345}. \tag{4.21}$$

Note that $a_{12345}^{\prime\mu}$ only satisfies Lie symmetries in its first four labels, as one can check via $h_{1234} = -h_{2134}$ and $h_{1234} + h_{2314} + h_{3124} = 0$ as well as $h_{123} = h_{[123]}$. This endows the resulting h_{12345} on the right-hand side with the same Lie symmetries in its first four legs and an additional reflection property $h_{12345} + h_{45312} = 0$. On these grounds, the redefinition

$$a_{12345}^\mu = a_{12345}^{\prime\mu} - k_{12345}^\mu h_{12345} \tag{4.22}$$

leads to the desired Lie symmetries in all the five labels

$$\begin{aligned}
 a_{12345}^\mu &= -a_{12345}^\mu, & a_{12345}^\mu + a_{23145}^\mu + a_{31245}^\mu &= 0, & a_{12345}^\mu - a_{12435}^\mu + a_{34125}^\mu - a_{34215}^\mu &= 0 \\
 a_{12345}^\mu - a_{12354}^\mu + a_{45123}^\mu - a_{45213}^\mu - a_{45312}^\mu + a_{45321}^\mu &= 0.
 \end{aligned} \tag{4.23}$$

¹⁸As an example for the antisymmetrization prescriptions in (4.18), the subtraction of $(a_P^\mu f_Q^{\nu\lambda} \leftrightarrow a_Q^\mu f_P^{\nu\lambda})$ extends the term $a_{123}^\mu f_4^{\nu\lambda}$ to the combination $a_{123}^\mu f_4^{\nu\lambda} - a_4^\mu f_{123}^{\nu\lambda}$.

The remaining multiparticle polarizations are given by

$$\begin{aligned}
 f_{12345}^{\mu\nu} &= k_{12345}^\mu a_{12345}^\nu - (k_{1234} \cdot k_5) a_{1234}^\mu a_5^\nu - (k_{123} \cdot k_4) (a_{1235}^\mu a_4^\mu + a_{123}^\mu a_{45}^\nu) \\
 &\quad - (k_{12} \cdot k_3) (a_{1245}^\mu a_3^\nu + a_{124}^\mu a_{35}^\nu + a_{125}^\mu a_{34}^\nu + a_{12}^\mu a_{345}^\nu) \\
 &\quad - (k_1 \cdot k_2) (a_{1345}^\mu a_2^\nu + a_{134}^\mu a_{25}^\nu + a_{135}^\mu a_{24}^\nu + a_{145}^\mu a_{23}^\nu \\
 &\quad\quad + a_{13}^\mu a_{245}^\nu + a_{14}^\mu a_{235}^\nu + a_{15}^\mu a_{234}^\nu + a_1^\mu a_{2345}^\nu) - (\mu \leftrightarrow \nu), \tag{4.24}
 \end{aligned}$$

and similar expressions for $f_{12345}^{\mu|\nu\lambda}$ and $g_{12345}^{\mu\nu|\lambda\rho}$ can be inferred by analogy with (4.18) or from the all-rank formula (4.31).

We emphasize that the expressions for the scalars $h_{12\dots p}$ result from a fully constructive procedure, i.e. they can be read off from (4.8), (4.15) and (4.21) after factoring out $k_{12\dots p}^\mu$. Similar to (4.9), one can use the cyclic building block (3.15) to rewrite

$$\begin{aligned}
 h_{1234} &= \frac{1}{24} (2s_{12}\mathfrak{M}_{12,3,4} + s_{13}\mathfrak{M}_{13,2,4} - s_{14}\mathfrak{M}_{14,2,3} - s_{23}\mathfrak{M}_{23,1,4} + s_{24}\mathfrak{M}_{24,1,3} + 2s_{34}\mathfrak{M}_{34,1,2}) \\
 &= +\frac{1}{48} ((k_{123} \cdot a_4)\mathfrak{M}_{1,2,3} - (k_{234} \cdot a_1)\mathfrak{M}_{2,3,4} + (k_{134} \cdot a_2)\mathfrak{M}_{1,3,4} - (k_{124} \cdot a_3)\mathfrak{M}_{1,2,4}) \\
 &\quad + \frac{1}{8} (s_{12}\mathfrak{M}_{12,3,4} + s_{34}\mathfrak{M}_{34,1,2}) \tag{4.25}
 \end{aligned}$$

and similar expressions for h_{12345} are spelt out in appendix B.1.

4.3 Local multiparticle polarizations at higher rank

The recursive construction of multiparticle polarizations will now be summarized in terms of all-rank formulae that closely follow their superspace antecedents [15] but incorporate α' -corrections. The Lie symmetries of $a_{12\dots q}^\mu$, $f_{12\dots q}^{\mu\nu}$, $f_{12\dots q}^{\mu|\nu\lambda}$ and $g_{12\dots q}^{\mu\nu|\lambda\rho}$ at lower rank $q = p-1$ propagate to the first $p-1$ labels of the following quantity:

$$\begin{aligned}
 \widehat{a}_{12\dots p}^\mu &= \frac{1}{2} \left[(k_p \cdot a_{12\dots p-1}) a_p^\mu - (k_{12\dots p-1} \cdot a_p) a_{12\dots p-1}^\mu + a_{12\dots p-1}^\nu f_p^{\nu\mu} - a_p^\nu f_{12\dots p-1}^{\nu\mu} \right. \\
 &\quad \left. + 2\alpha' (f_{12\dots p-1}^{\nu\lambda} f_p^{\nu|\lambda\mu} - f_p^{\nu\lambda} f_{12\dots p-1}^{\nu|\lambda\mu}) + 4\alpha'^2 g_{12\dots p-1}^{\nu\mu|\rho\sigma} f_p^{\nu|\rho\sigma} \right]. \tag{4.26}
 \end{aligned}$$

When reinstating the vanishing term $0 = -2\alpha'^2 g_p^{\nu\mu|\rho\sigma} f_{12\dots p-1}^{\nu|\rho\sigma}$, this expression exhibits formal antisymmetry under exchange of labels $12\dots p-1 \leftrightarrow p$. In order to isolate the deviations from the Lie symmetries at rank p , one first has to subtract¹⁹

$$a_{12\dots p}^{\mu} = \widehat{a}_{12\dots p}^\mu - \sum_{j=2}^{p-1} (k_{12\dots j-1} \cdot k_j) \sum_{\substack{j+1, j+2, \dots, p-1 \\ = X \sqcup Y}} (h_{12\dots (j-1)Yp} a_{jX}^\mu - h_{jYp} a_{12\dots (j-1)X}^\mu), \tag{4.27}$$

with $h_i = h_{ij} = 0$ as well as h_{ijk} and h_{ijkl} defined in (4.9) and (4.25), respectively. These subtractions vanish at rank $p \leq 3$, and their instances at $p = 4, 5$ are spelt out in (4.14) and (4.20), respectively. These equations might be helpful to see an example

¹⁹OS is grateful to Carlos Mafra for identifying the property $j+1, j+2 \dots p-1 = X \sqcup Y$ of the words X, Y in the second sum of (4.27).

of the summation prescription of the form $a_1 a_2 \dots a_k = X \sqcup Y$ in (4.27): for a given k -particle label $a_1 a_2 \dots a_k$, the sum runs over all the 2^k pairs of words X and Y whose shuffle product contains $a_1 a_2 \dots a_k$, for instance²⁰ $(X, Y) = (\emptyset, \emptyset)$ in case of $k = 0$ as well as $(X, Y) = (a_1, \emptyset)$ and $(X, Y) = (\emptyset, a_1)$ in case of $k = 1$.

The outcome of (4.27) still obeys the Lie symmetries in the first $p-1$ labels and is claimed to factorize $k_{12\dots p}^\mu$ when probing the rank- p Lie symmetry:

$$\left. \begin{aligned} a_{12\dots n+1[n+2[\dots[2n-1[2n, 2n+1]\dots]]] - a_{2n+1, 2n, \dots, n+2[n+1[\dots[3[21]]\dots]]}^\mu & : p = 2n+1 \text{ odd} \\ a_{12\dots n[n+1[\dots[2n-2[2n-1, 2n]\dots]]] + a_{2n, 2n-1, \dots, n+1[n[\dots[3[21]]\dots]]}^\mu & : p = 2n \text{ even} \end{aligned} \right\} = p k_{12\dots p}^\mu h_{12\dots p}. \quad (4.28)$$

The symmetries of the scalar $h_{12\dots p}$ induced by the left-hand side ensure that the final form

$$a_{12\dots p}^\mu = a_{12\dots p}^{\prime\mu} - k_{12\dots p}^\mu h_{12\dots p} \quad (4.29)$$

of the multiparticle polarizations obeys all the Lie symmetries of the color factor (4.1),

$$0 = \begin{cases} a_{12\dots n+1[n+2[\dots[2n-1[2n, 2n+1]\dots]]] - a_{2n+1, 2n, \dots, n+2[n+1[\dots[3[21]]\dots]]}^\mu & : p = 2n+1 \text{ odd} \\ a_{12\dots n[n+1[\dots[2n-2[2n-1, 2n]\dots]]] + a_{2n, 2n-1, \dots, n+1[n[\dots[3[21]]\dots]]}^\mu & : p = 2n \text{ even} \end{cases}. \quad (4.30)$$

Hence, when interpreted as the kinematic numerator of the off-shell diagram in figure 9, the multiparticle polarization $a_{12\dots p}^\mu$ in (4.29) obeys kinematic Jacobi identities.

The remaining multiparticle polarizations $f_{12\dots p}^{\mu\nu}$, $f_{12\dots p}^{\mu|\nu\lambda}$ and $g_{12\dots p}^{\mu\nu|\lambda\rho}$ of higher mass dimension are obtained by the following generalization of (4.12), (4.18) and (4.24)

$$\begin{aligned} f_{12\dots p}^{\mu\nu} &= k_{12\dots p}^\mu a_{12\dots p}^\nu - \sum_{j=2}^p (k_{12\dots j-1} \cdot k_j) \sum_{\substack{j+1, j+2 \dots p \\ = X \sqcup Y}} a_{12\dots j-1X}^\mu a_{jY}^\nu - (\mu \leftrightarrow \nu) \\ f_{12\dots p}^{\mu|\nu\lambda} &= k_{12\dots p}^\mu f_{12\dots p}^{\nu\lambda} - \left[\sum_{j=2}^p (k_{12\dots j-1} \cdot k_j) \sum_{\substack{j+1, j+2 \dots p \\ = X \sqcup Y}} a_{12\dots j-1X}^\mu f_{jY}^{\nu\lambda} - (a_P^\mu f_Q^{\nu\lambda} \leftrightarrow a_Q^\mu f_P^{\nu\lambda}) \right] \end{aligned} \quad (4.31)$$

$$g_{12\dots p}^{\mu\nu|\lambda\rho} = \sum_{j=2}^p (k_{12\dots j-1} \cdot k_j) \sum_{\substack{j+1, j+2 \dots p \\ = X \sqcup Y}} f_{12\dots j-1X}^{\mu\nu} f_{jY}^{\lambda\rho} - (f_P^{\mu\nu} f_Q^{\lambda\rho} \leftrightarrow f_Q^{\mu\nu} f_P^{\lambda\rho}),$$

see the explanation above for the summation prescription $j+1, j+2 \dots p = X \sqcup Y$. The pattern of contact terms on the right-hand side preserves the Lie symmetries in all the p labels and will be connected with Berends-Giele currents in section 5.1. In the next section, these four Jacobi-satisfying kinematic representatives (4.29) and (4.31) of the off-shell diagram in figure 9 will be combined to on-shell numerators of $(\text{YM} + F^3 + F^4)$.

²⁰As a rank-two example of the above summation prescription, $a_1 a_2 = X \sqcup Y$ allows for the four choices of (X, Y) , namely $(a_1 a_2, \emptyset)$, $(\emptyset, a_1 a_2)$, (a_1, a_2) , (a_2, a_1) .

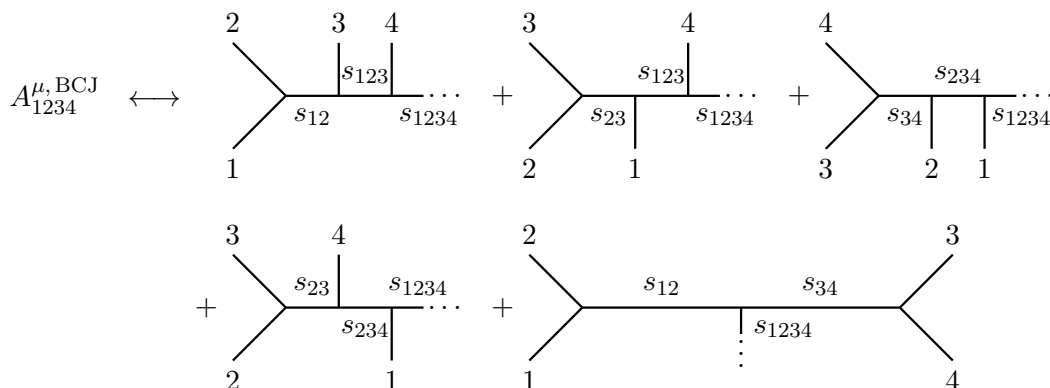

Figure 12. Cubic-diagram expansion of the rank-four Berends-Giele current $A_{1234}^{\mu, BCJ}$ built from multiparticle polarizations.

5 BCJ gauge and BCJ numerators for $(YM+F^3+F^4)$

5.1 Berends-Giele currents in BCJ gauge

In this section, we relate the Jacobi-satisfying numerators for cubic off-shell diagrams as constructed in the previous section to gauge-transformed Berends-Giele currents. The idea is to compare the Lorenz-gauge currents $A_P^\mu, F_P^{\mu\nu}, F_P^{\mu|\nu\lambda}$ and $G_P^{\mu\nu|\lambda\rho}$ of section 3.1 with alternative currents $A_P^{\mu, BCJ}, \dots, G_P^{\mu\nu|\lambda\rho, BCJ}$ obtained from multiparticle polarizations. More precisely, these alternative currents are defined by combining cubic diagrams in the usual color-ordered manner and dressing them with multiparticle polarizations and propagators. The simplest examples are $A_1^{\mu, BCJ} = e_1^\mu$ as well as

$$\begin{aligned}
 A_{12}^{\mu, BCJ} &= \frac{a_{12}^\mu}{s_{12}}, & A_{123}^{\mu, BCJ} &= \frac{a_{123}^\mu}{s_{12}s_{123}} + \frac{a_{321}^\mu}{s_{23}s_{123}} \\
 A_{1234}^{\mu, BCJ} &= \frac{1}{s_{1234}} \left\{ \frac{a_{1234}^\mu}{s_{12}s_{123}} + \frac{a_{3214}^\mu}{s_{23}s_{123}} + \frac{a_{1234}^\mu - a_{1243}^\mu}{s_{12}s_{34}} - \frac{a_{4321}^\mu}{s_{34}s_{234}} - \frac{a_{2341}^\mu}{s_{23}s_{234}} \right\},
 \end{aligned}
 \tag{5.1}$$

and similar definitions apply to $F_{\dots}^{\mu\nu, BCJ}, F_{\dots}^{\mu|\nu\lambda, BCJ}, G_{\dots}^{\mu\nu|\lambda\rho, BCJ}$ with $a_{\dots}^\mu \rightarrow f_{\dots}^{\mu\nu}, f_{\dots}^{\mu|\nu\lambda}, g_{\dots}^{\mu\nu|\lambda\rho}$ on the right-hand side of (5.1). The rank-two currents are degenerate with $A_{12}^{\mu, BCJ} = A_{12}^\mu$, while the redefinitions of numerators $a_{12\dots p}^\mu$ at ranks $p \geq 3$ by $h_{12\dots p}$ introduce differences between A_P^μ from the recursion (3.11) and the alternative currents in (5.1).

At rank three, there are two cubic diagrams contributing to $A_{123}^{\mu, BCJ}$ after dropping the distinction between order- $\alpha'^0, \alpha'^1, \alpha'^2$ vertices in figure 7, and the five cubic diagrams at rank four are depicted in figure 12. The numerator for the last cubic diagram of $A_{1234}^{\mu, BCJ}$ in the figure with propagators $(s_{12}s_{34}s_{1234})^{-1}$ is defined to be $a_{1234}^\mu - a_{1243}^\mu$ by its relation to half-ladder numerators via Jacobi identities.²¹

More generally, each cubic diagram contributing to $A_{12\dots p}^{\mu, BCJ}$ can be derived from the half-ladder topology via kinematic Jacobi relations. The half-ladder numerators at rank

²¹The Lie symmetry $a_{1234}^\mu - a_{1243}^\mu = -(a_{3412}^\mu - a_{3421}^\mu)$ ensures that this numerator changes sign when trading $12 \leftrightarrow 34$ by a flip of the central cubic vertex and therefore obeys (2.28).

p in turn can be expanded in the $(p-1)!$ -element basis $\{a_{1\rho(23\dots p)}^\mu, \rho \in S_{p-1}\}$ by their Lie symmetries (4.30). As already noted in a superspace context [15, 19], currents and master numerators are related by the inverse of the $(p-1)! \times (p-1)!$ KLT matrix in (2.42),

$$\begin{aligned} A_{1\rho(23\dots p)}^{\mu, \text{BCJ}} &= \sum_{\sigma \in S_{p-1}} \Phi(\rho|\sigma)_1 a_{1\sigma(23\dots p)}^\mu, & F_{1\rho(23\dots p)}^{\mu\nu, \text{BCJ}} &= \sum_{\sigma \in S_{p-1}} \Phi(\rho|\sigma)_1 f_{1\sigma(23\dots p)}^{\mu\nu} \\ F_{1\rho(23\dots p)}^{\mu|\nu\lambda, \text{BCJ}} &= \sum_{\sigma \in S_{p-1}} \Phi(\rho|\sigma)_1 f_{1\sigma(23\dots p)}^{\mu|\nu\lambda}, & G_{1\rho(23\dots p)}^{\mu\nu|\lambda\rho, \text{BCJ}} &= \sum_{\sigma \in S_{p-1}} \Phi(\rho|\sigma)_1 g_{1\sigma(23\dots p)}^{\mu\nu|\lambda\rho}. \end{aligned} \quad (5.2)$$

The cubic-graph expansion endows the alternative currents $A_P^{\mu, \text{BCJ}}, \dots, G_P^{\mu\nu|\lambda\rho, \text{BCJ}}$ with the same shuffle relations (3.10) as the Lorenz-gauge currents $A_P^\mu, \dots, G_P^{\mu\nu|\lambda\rho}$. Hence, the former also descend from Lie-algebra valued perturbinors [74] such as

$$\mathbb{A}^{\mu, \text{BCJ}} = \sum_{P \neq \emptyset} A_P^{\mu, \text{BCJ}} t^P e^{k_P \cdot x}, \quad \mathbb{F}^{\mu\nu, \text{BCJ}} = \sum_{P \neq \emptyset} F_P^{\mu\nu, \text{BCJ}} t^P e^{k_P \cdot x}. \quad (5.3)$$

By direct comparison of the currents $A_P^\mu, F_P^{\mu\nu}$ and $A_P^{\mu, \text{BCJ}}, F_P^{\mu\nu, \text{BCJ}}$, the redefinitions of the multiparticle polarizations via $h_{12\dots p}$ conspire to shuffle symmetric scalars $H_{12\dots p}$,

$$\begin{aligned} A_{123}^{\mu, \text{BCJ}} &= A_{123}^\mu + k_{123}^\mu H_{123}, & F_{123}^{\mu\nu, \text{BCJ}} &= F_{123}^{\mu\nu} \\ A_{1234}^{\mu, \text{BCJ}} &= A_{1234}^\mu - A_1^\mu H_{234} + H_{123} A_4^\mu + k_{1234}^\mu H_{1234} \\ F_{1234}^{\mu\nu, \text{BCJ}} &= F_{1234}^{\mu\nu} - F_1^{\mu\nu} H_{234} + H_{123} F_4^{\mu\nu}, \end{aligned} \quad (5.4)$$

for instance

$$H_{123} = \frac{h_{123}}{s_{123}} \left(\frac{1}{s_{23}} - \frac{1}{s_{12}} \right) = \frac{\mathfrak{M}_{1,2,3}}{6s_{123}} \left(\frac{1}{s_{23}} - \frac{1}{s_{12}} \right) \quad (5.5)$$

$$\begin{aligned} H_{1234} &= \frac{1}{s_{1234}} \left\{ h_{1234} \left(\frac{1}{s_{34}s_{234}} - \frac{1}{s_{12}s_{123}} \right) - \frac{h_{3214}}{s_{23}} \left(\frac{1}{s_{123}} - \frac{1}{s_{234}} \right) + \frac{1}{4} \left(\frac{\mathfrak{M}_{12,3,4}}{s_{34}} - \frac{\mathfrak{M}_{34,1,2}}{s_{12}} \right) \right. \\ &+ \frac{1}{12} \left((k_{123} \cdot a_4) \frac{\mathfrak{M}_{1,2,3}}{s_{123}} \left(\frac{1}{s_{12}} - \frac{1}{s_{23}} \right) + (k_{234} \cdot a_1) \frac{\mathfrak{M}_{2,3,4}}{s_{234}} \left(\frac{1}{s_{34}} - \frac{1}{s_{23}} \right) \right) \\ &\left. + \frac{1}{24s_{12}s_{34}} [\mathfrak{M}_{1,2,3}(k_{123} \cdot a_4) - \mathfrak{M}_{1,2,4}(k_{124} \cdot a_3) - \mathfrak{M}_{1,3,4}(k_{134} \cdot a_2) + \mathfrak{M}_{2,3,4}(k_{234} \cdot a_1)] \right\}. \end{aligned} \quad (5.6)$$

An alternative expression for H_{1234} can be found in appendix B.2.

Given that $H_i = H_{ij} = 0$, the redefinitions (5.4) up to rank four line up with the general form of a non-linear gauge transformation (3.22)

$$\begin{aligned} A_P^{\mu, \text{BCJ}} &= A_P^\mu + k_P^\mu H_P - \sum_{XY=P} (A_X^\mu H_Y - A_Y^\mu H_X) \\ F_P^{\mu\nu, \text{BCJ}} &= F_P^{\mu\nu} - \sum_{XY=P} (F_X^{\mu\nu} H_Y - F_Y^{\mu\nu} H_X) \\ F_P^{\mu|\nu\lambda, \text{BCJ}} &= F_P^{\mu|\nu\lambda} - \sum_{XY=P} (F_X^{\mu|\nu\lambda} H_Y - F_Y^{\mu|\nu\lambda} H_X) \\ G_P^{\mu\nu|\lambda\rho, \text{BCJ}} &= G_P^{\mu\nu|\lambda\rho} - \sum_{XY=P} (G_X^{\mu\nu|\lambda\rho} H_Y - G_Y^{\mu\nu|\lambda\rho} H_X) \end{aligned} \quad (5.7)$$

with gauge parameters $\Omega_P \rightarrow H_P$. These transformations are checked to apply to all currents up to and including rank five, see appendix B.3 for the explicit form of H_{12345} , and the existence of suitable $H_{12\dots p}$ is conjectural at higher rank $p \geq 6$.

As the punchline of (5.7), the local Jacobi-satisfying numerators for off-shell diagrams are related to Lorenz-gauge currents through a non-linear gauge transformation generated by

$$\Omega = \sum_{i,j,l} H_{ijl} t^i t^j t^l e^{k_{ijl} \cdot x} + \sum_{i,j,l,m} H_{ijlm} t^i t^j t^l t^m e^{k_{ijlm} \cdot x} + \dots = \sum_{|P| \geq 3} H_P t^P e^{k_P \cdot x}. \quad (5.8)$$

In the next sections, the local multiparticle polarizations will be used to manifest the BCJ duality between color and kinematics in tree-level amplitudes of $(\text{YM}+F^3+F^4)$. Hence, the transformed currents $A_P^{\mu, \text{BCJ}}, \dots, G_P^{\mu\nu|\lambda\rho, \text{BCJ}}$ related by (5.2) are said to be in *BCJ gauge* [27, 28]. Note that the first perturbative solutions to the field equations of ten-dimensional SYM were actually constructed in BCJ gauge [91].

5.2 Kinematic derivation of the BCJ relations

As a first application of BCJ-gauge currents, we derive the BCJ relations (2.30) of $\mathcal{A}_{\text{YM}+F^3+F^4}$ amplitudes by inverting their correspondence (5.2) with multiparticle polarizations. The same sequence of arguments has been applied to derive BCJ relations for tree amplitudes of ten-dimensional SYM from superspace currents in BCJ gauge [28], and we adapt the reasoning of the reference to the bosonic amplitudes up to the α'^2 -order.

At rank p , inversion of (5.2) relates multiparticle polarizations to BCJ-gauge currents via

$$\begin{aligned} a_{1\sigma(23\dots p)}^\mu &= \sum_{\tau \in S_{p-1}} S(\sigma|\tau)_1 A_{1\tau(23\dots p)}^{\mu, \text{BCJ}}, & f_{1\sigma(23\dots p)}^{\mu\nu} &= \sum_{\tau \in S_{p-1}} S(\sigma|\tau)_1 F_{1\tau(23\dots p)}^{\mu\nu, \text{BCJ}} \\ f_{1\sigma(23\dots p)}^{\mu|\nu\lambda} &= \sum_{\tau \in S_{p-1}} S(\sigma|\tau)_1 F_{1\tau(23\dots p)}^{\mu|\nu\lambda, \text{BCJ}}, & g_{1\sigma(23\dots p)}^{\mu\nu|\lambda\tau} &= \sum_{\tau \in S_{p-1}} S(\sigma|\tau)_1 G_{1\tau(23\dots p)}^{\mu\nu|\lambda\tau, \text{BCJ}}, \end{aligned} \quad (5.9)$$

where $S(\sigma|\rho)_1$ denotes the KLT matrix defined in (2.39). The Lie symmetries of the numerators of the BCJ-gauge currents ensure that the Mandelstam invariants from $S(\sigma|\rho)_1$ cancel all of their kinematic poles on the right-hand sides of (5.9). However, when repeating these matrix multiplications with Lorenz-gauge currents A_P^μ , some of the kinematic poles in $(m \geq 3)$ -particle channels persist²² in $\sum_{\tau \in S_{p-1}} S(\sigma|\tau)_1 A_{1\tau(23\dots p)}^\mu$ with $p \geq 3$. Hence, it is a peculiarity of BCJ-gauge currents that *local* objects are obtained from matrix multiplication with $S(\sigma|\rho)_1$. Similarly, the pole $s_{12\dots p}^{-1}$ in the p -particle channel drops out from the following rank- p combinations of BCJ-gauge currents,

$$\begin{aligned} a_{12}^\mu &= s_{12} A_{12}^{\mu, \text{BCJ}}, & \frac{a_{123}^\mu}{s_{12}} &= s_{23} A_{123}^{\mu, \text{BCJ}} - s_{13} A_{213}^{\mu, \text{BCJ}} \\ \frac{a_{1234}^\mu}{s_{12}s_{123}} + \frac{a_{3214}^\mu}{s_{23}s_{123}} &= s_{34} A_{1234}^{\mu, \text{BCJ}} - s_{24} (A_{1324}^{\mu, \text{BCJ}} + A_{3124}^{\mu, \text{BCJ}}) + s_{14} A_{3214}^{\mu, \text{BCJ}}, \end{aligned} \quad (5.10)$$

²²For instance, the product $\sum_{\tau \in S_2} S(2,3|\tau)_1 A_{1\tau(23)}^\mu = s_{12}(s_{23} A_{123}^\mu - s_{13} A_{213}^\mu)$ can be thought of as a Lorenz-gauge analogue of a_{123}^μ and exhibits a pole in s_{123} with residue $\sim s_{12} k_{123}^\mu h_{123}$.

i.e. they are non-singular as $s_{12\dots p} \rightarrow 0$ but obviously exhibit poles in lower-multiplicity channels such as $s_{12\dots p-1}^{-1}$. The same is true for the rank-five expression

$$\frac{1}{s_{1234}} \left(\frac{a_{12345}^\mu}{s_{12}s_{123}} + \frac{a_{32145}^\mu}{s_{23}s_{123}} - \frac{a_{43215}^\mu}{s_{34}s_{234}} - \frac{a_{23415}^\mu}{s_{23}s_{234}} + \frac{a_{12345}^\mu - a_{12435}^\mu}{s_{12}s_{34}} \right) \quad (5.11)$$

$$= s_{45}A_{12345}^{\mu, \text{BCJ}} - s_{35}A_{(12\sqcup 4)35}^{\mu, \text{BCJ}} + s_{25}A_{(43\sqcup 1)25}^{\mu, \text{BCJ}} - s_{15}A_{43215}^{\mu, \text{BCJ}}.$$

This can be used to derive BCJ relations among color-ordered $(\text{YM}+F^3+F^4)$ amplitudes. We exploit that the amplitude formula (3.12) is invariant under non-linear gauge transformations — see section 3.3 — and can therefore be written in terms of BCJ-gauge currents,

$$\mathcal{A}_{\text{YM}+F^3+F^4}(1, 2, \dots, n-1, n) = s_{12\dots n-1}A_{12\dots n-1}^{\mu, \text{BCJ}}A_n^\mu. \quad (5.12)$$

The right-hand side is nonzero and finite by the interplay of the vanishing Mandelstam invariant $s_{12\dots n-1}$ and the compensating $(n-1)$ -particle pole of $A_{12\dots n-1}^{\mu, \text{BCJ}}$. If the propagator $s_{12\dots n-1}^{-1}$ cancels in a linear combination of currents, then multiplication with $s_{12\dots n-1}$ yields vanishing expressions in the n -particle momentum phase space. For instance, since $s_{23}A_{123}^{\mu, \text{BCJ}} - s_{13}A_{213}^{\mu, \text{BCJ}} = a_{123}^\mu/s_{12}$ does not have the pole s_{12}^{-1} of the individual currents, the quantity $s_{123}a_{123}^\mu/s_{12} = s_{123}(s_{23}A_{123}^{\mu, \text{BCJ}} - s_{13}A_{213}^{\mu, \text{BCJ}})$ vanishes by four-particle momentum conservation. In combination with the amplitude formula (5.12), this implies the four-point BCJ relation (2.30)

$$0 = \frac{s_{123}a_{123}^\mu}{s_{12}} = s_{123}(s_{23}A_{123}^{\mu, \text{BCJ}} - s_{13}A_{213}^{\mu, \text{BCJ}})$$

$$= s_{23}\mathcal{A}_{\text{YM}+F^3+F^4}(1, 2, 3, 4) - s_{13}\mathcal{A}_{\text{YM}+F^3+F^4}(2, 1, 3, 4). \quad (5.13)$$

Similarly, the rank- $(p \leq 5)$ combinations in (5.10) and (5.11) with regular $s_{12\dots p} \rightarrow 0$ limit imply the following five- and six-point BCJ relations after multiplication with the vanishing $(p = n-1)$ -point Mandelstam invariant $s_{12\dots p}$,

$$0 = s_{1234} \left(\frac{a_{1234}^\mu}{s_{12}s_{123}} + \frac{a_{3214}^\mu}{s_{23}s_{123}} \right) = s_{34}\mathcal{A}_{\text{YM}+F^3+F^4}(1, 2, 3, 4, 5)$$

$$- s_{24}(\mathcal{A}_{\text{YM}+F^3+F^4}(1, 3, 2, 4, 5) + \mathcal{A}_{\text{YM}+F^3+F^4}(3, 1, 2, 4, 5)) + s_{14}\mathcal{A}_{\text{YM}+F^3+F^4}(3, 2, 1, 4, 5)$$

$$0 = \frac{s_{12345}}{s_{1234}} \left(\frac{a_{12345}^\mu}{s_{12}s_{123}} + \frac{a_{32145}^\mu}{s_{23}s_{123}} - \frac{a_{43215}^\mu}{s_{34}s_{234}} - \frac{a_{23415}^\mu}{s_{23}s_{234}} + \frac{a_{12345}^\mu - a_{12435}^\mu}{s_{12}s_{34}} \right) \quad (5.14)$$

$$= s_{45}\mathcal{A}_{\text{YM}+F^3+F^4}(1, 2, 3, 4, 5, 6) - s_{35}\mathcal{A}_{\text{YM}+F^3+F^4}((1, 2\sqcup 4), 3, 5, 6)$$

$$+ s_{25}\mathcal{A}_{\text{YM}+F^3+F^4}((4, 3\sqcup 1), 2, 5, 6) - s_{15}\mathcal{A}_{\text{YM}+F^3+F^4}(4, 3, 2, 1, 5, 6).$$

This calls for an all-multiplicity formula for analogous combinations with regular behaviour as $s_{12\dots p} \rightarrow 0$: the right-hand sides of (5.10) can be generated through the S -map [15, 28]

$$A_{S[P,Q]}^{\mu, \text{BCJ}} = \sum_{i=1}^{|P|} \sum_{j=1}^{|Q|} (-1)^{i-j+|P|-1} s_{p_i q_j} A_{(p_1 p_2 \dots p_{i-1} \sqcup p_i | p_{i+1} \dots p_{|P|-1} \dots p_i q_j (q_{j-1} \dots q_2 q_1 \sqcup q_{j+1} \dots q_{|Q|})}^{\mu, \text{BCJ}} \quad (5.15)$$

involving words $P = p_1 p_2 \dots p_{|P|}$ and $Q = q_1 q_2 \dots q_{|Q|}$. BCJ gauge of the currents implies that the S -map defined in (5.15) removes the pole in s_{PQ} [15] and therefore paves the way for the following form of the BCJ relations [28]

$$\begin{aligned}
 0 &= (-1)^{|P|-1} s_{PQ} A_{S[P,Q]}^{\mu, \text{BCJ}} A_n^\mu \\
 &= \sum_{i=1}^{|P|} \sum_{j=1}^{|Q|} (-1)^{i-j} s_{p_i q_j} \mathcal{A}_{\text{YM}+F^3+F^4}((p_1 p_2 \dots p_{i-1} \sqcup p_{|P|} \dots p_{i+1}), p_i, q_j, (q_{j-1} \dots q_{1 \sqcup} q_{j+1} \dots q_{|Q|}), n).
 \end{aligned}
 \tag{5.16}$$

Suitable choices of P and Q in (5.16) reproduce various representations of the BCJ relations [2, 11, 12, 92]. Setting $P = 1$ and $Q = 23 \dots n-1$, for instance, one recovers a form of the BCJ relations

$$0 = \sum_{j=2}^{n-1} (-1)^j s_{1j} \mathcal{A}_{\text{YM}+F^3+F^4}(1, j, (j-1, j-2, \dots, 3, 2 \sqcup j+1, \dots, n-1), n)
 \tag{5.17}$$

which is equivalent to (2.30) by the KK relations $\mathcal{A}_{\text{YM}+F^3+F^4}((X \sqcup Y), n) = 0 \forall X, Y \neq \emptyset$.

5.3 Local Jacobi-satisfying numerators

In this section, we will exploit the multiparticle polarizations of $(\text{YM}+F^3+F^4)$ to construct local and Jacobi-satisfying cubic-diagram numerators. The most direct approach is to expand the BCJ-gauge current in the amplitude representation (5.12) via (5.2),

$$\mathcal{A}_{\text{YM}+F^3+F^4}(1, \tau(2, \dots, n-1), n) = \sum_{\rho \in S_{n-2}} s_{12\dots n-1} \Phi(\tau|\rho)_1 a_{1\rho(23\dots n-1)}^\mu e_n^\mu, \quad \tau \in S_{n-2},
 \tag{5.18}$$

where the formally vanishing Mandelstam invariant in $s_{12\dots n-1} \Phi(\tau|\rho)_1$ cancels in each entry of the inverse KLT matrix (see the recursion in (2.41) and (2.42)). From the remaining propagators in $\Phi(\tau|\rho)_1$, the expressions $a_{1\rho(23\dots n-1)}^\mu e_n^\mu$ will be shown below to take the role of master numerators of the half-ladder diagrams depicted in figure 6. The $(n-2)!$ KK-independent permutations of $\mathcal{A}_{\text{YM}+F^3+F^4}$ in (5.18) incorporate each cubic diagram at least once and therefore define all of the numerators.

In order to demonstrate that the numerators in (5.18) obey kinematic Jacobi identities, we bring it into the form of the general amplitude representation (2.36) with manifest color-kinematics duality,

$$\mathcal{A}_{\text{YM}+F^3+F^4}(\sigma(1, 2, \dots, n)) = \sum_{\rho \in S_{n-2}} m(\sigma|1, \rho(2, \dots, n-1), n) a_{1\rho(23\dots n-1)}^\mu e_n^\mu, \quad \sigma \in S_n.
 \tag{5.19}$$

Consistency with (5.18) can be conveniently checked by expressing $\Phi(\tau|\rho)_1$ with $\tau, \rho \in S_{n-2}$ as a putative $(n+1)$ -point doubly-partial amplitude $-m(1, \tau, n, n+1|1, \rho, n+1, n)$ via (2.38) and (2.42). By its Berends-Giele representation (2.40) [63], the latter can be written as

$$\Phi(\tau|\rho)_1 = -s_{12\dots n} \phi_{1\tau n|n1\rho} = - \sum_{XY=1\tau n} \sum_{AB=n1\rho} (\phi_{X|A} \phi_{Y|B} - \phi_{Y|A} \phi_{X|B}).
 \tag{5.20}$$

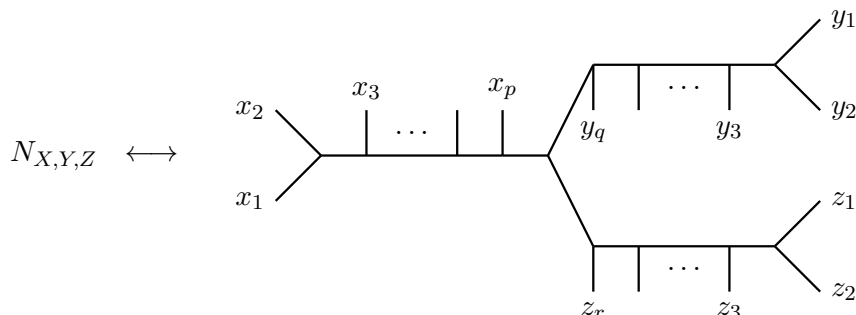

Figure 13. Diagrammatic interpretation of the local building block $N_{X,Y,Z}$ with multiparticle labels $X = x_1 x_2 \dots x_p$, $Y = y_1 y_2 \dots y_q$ and $Z = z_1 z_2 \dots z_r$ referring to three off-shell half-ladder diagrams that are connected by the central vertex. Note that we no longer distinguish between the orders of α' carried by the individual cubic vertices and therefore suppress the white and black dots of figure 8.

Since $\phi_{P|Q}$ vanishes unless P is a permutation of Q , the only contribution arises from the deconcatenations with $A = n$ and $Y = n$ leading to

$$s_{12\dots n-1} \Phi(\tau|\rho)_1 = -s_{12\dots n-1} (\phi_{1\tau|n} \phi_{n|1\rho} - \phi_{n|n} \phi_{1\tau|1\rho}) = m(1, \tau, n|1, \rho, n). \quad (5.21)$$

Hence, (5.19) at $\sigma = (1, \tau, n)$ reduces to (5.18). For other choices of σ in turn, validity of (5.19) follows from the KK relations of both sides. Hence, by the discussion around (2.36), the cubic-diagram numerators of (5.18) are composed from the masters $a_{1\rho(23\dots n-1)}^\mu e_n^\mu$ as dictated by Jacobi identities.

Note that the cubic-diagram numerators in (5.18) and (5.19) are not crossing symmetric, i.e. their functional form in terms of polarizations and momenta depends on the position of the singled-out legs 1 and n in the diagram.

In the same way as the manifestly cyclic representations of section 3.2 assemble n -point amplitudes from Berends-Giele currents of maximum rank $\lfloor \frac{n}{2} \rfloor$, we will next spell out alternative numerators in terms of lower-rank multiparticle polarizations. In analogy to the cyclic building block $\mathfrak{M}_{X,Y,Z}$ in (3.15) composed of Lorenz-gauge currents, we define the local combination

$$\begin{aligned} N_{X,Y,Z} = & \frac{1}{2} (a_X^\mu f_Y^{\mu\nu} a_Z^\nu + \text{cyc}(X, Y, Z)) - 2\alpha' f_X^{\mu\nu} f_Y^{\nu\lambda} f_Z^{\lambda\mu} \\ & + \left(\frac{\alpha'}{2} f_X^{\mu|\nu\lambda} f_Y^{\nu\lambda} a_Z^\mu + 2\alpha'^2 g_X^{\mu\nu|\lambda\rho} f_Y^{\mu|\lambda\rho} a_Z^\nu \pm \text{perm}(X, Y, Z) \right) \\ & + \left(\frac{\alpha'^2}{2} g_X^{\mu\nu|\lambda\rho} f_Y^{\mu\nu} f_Z^{\lambda\rho} - 2\alpha'^2 f_X^{\mu\nu} f_Y^{\mu|\lambda\rho} f_Z^{\nu|\lambda\rho} + \text{cyc}(X, Y, Z) \right) \end{aligned} \quad (5.22)$$

to describe the cubic diagram in figure 13 (see figure 8 for the analogous diagrammatic interpretation of $\mathfrak{M}_{X,Y,Z}$).

There is an ambiguity in relating cubic diagrams to the combinations $N_{X,Y,Z}$ in (5.22): each of the $n-2$ cubic vertices may be associated with the central vertex in figure 13, e.g.

$$\mathfrak{N}_{1a_1a_2\dots a_p|n|b_q\dots b_2b_1n-1} = (-1)^q N_{1a_1\dots a_p, n, (n-1)b_1\dots b_q} \longleftrightarrow$$

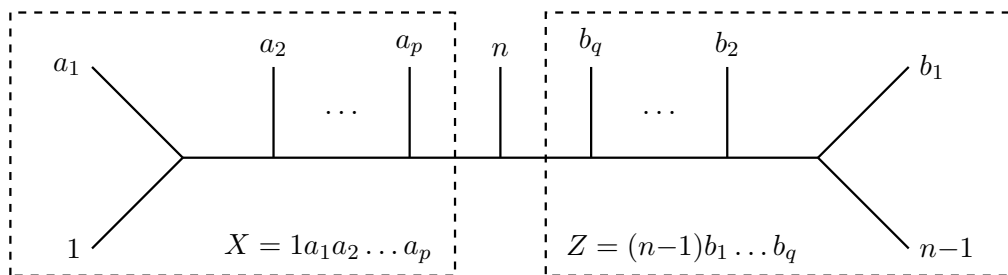

Figure 14. An alternative choice of master numerators composed of multiparticle polarizations of smaller rank as compared to (5.19). The external legs $a_1, a_2, \dots, a_p, b_1, b_2, \dots, b_q$ are permutations of $2, 3, \dots, n-2$ where $p+q = n-3$ and $p = 0, 1, \dots, n-3$.

all of $N_{123,4,5}$, $N_{12,3,45}$ and $N_{1,2,543}$ describe the same cubic diagram. A valid $(n-2)!$ -set of $N_{X,Y,Z}$ to serve as the master numerators for half-ladder diagrams is given by

$$\mathfrak{N}_{1a_1a_2\dots a_p|n|b_q\dots b_2b_1n-1} = (-1)^q N_{1a_1a_2\dots a_p, n, (n-1)b_1b_2\dots b_q}. \quad (5.23)$$

As a defining property of these master numerators \mathfrak{N}_{\dots} , the central vertex of figure 13 is always chosen to be adjacent to leg n which therefore enters in a single-particle slot. As depicted in figure 14, the numerators in (5.23) describe half-ladder diagrams with endpoints 1 and $n-1$, where the location of leg n decides about the partition into the three subdiagrams associated with the slots of $N_{X,Y,Z}$. The remaining labels $a_1, a_2, \dots, a_p, b_1, b_2, \dots, b_q$ are a permutation of $2, 3, \dots, n-2$ with $p+q = n-3$. Together with the $n-2$ different choices of $p = 0, 1, \dots, n-3$, this exhausts the total of $(n-2)!$ permutations of the larger set $2, 3, \dots, n-2, n$.

The collection of $\mathfrak{N}_{1a_1a_2\dots a_p|n|b_q\dots b_2b_1n-1}$ in (5.23) and figure 14 can be used as an alternative to the master numerators $a_{1\rho(23\dots n-1)}^\mu e_n^\mu$ in (5.19). As a practical advantage of the \mathfrak{N}_{\dots} , their constituents in (5.22) only require multiparticle polarizations of maximal rank $n-2$ instead of the rank- $(n-1)$ quantities $a_{1\rho(23\dots n-1)}^\mu$. As demonstrated in appendix C,²³ they yield Jacobi-satisfying amplitude representations of the form (2.36),

$$\begin{aligned} \mathcal{A}_{\text{YM}+F^3+F^4}(\sigma(1, 2, \dots, n)) &= \sum_{j=1}^{n-2} \sum_{\rho \in S_{n-3}} \mathfrak{N}_{1\rho(23\dots j)|n|\rho(j+1\dots n-2)n-1} \\ &\times m(\sigma|1, \rho(2, 3, \dots, j), n, \rho(j+1, \dots, n-2), n-1). \end{aligned} \quad (5.24)$$

Note that the $\alpha' \rightarrow 0$ order of (5.24) follows from the field-theory limit of the pure-spinor superstring based on the amplitude representations of [14, 63] and the superspace gauge described in [27].

Moreover, one can further reduce the maximum rank of the multiparticle polarizations by a generalization of the integration-by-parts relation (3.17). The latter still holds when

²³Also see [14, 63] for Jacobi-satisfying superspace numerators in ten-dimensional SYM with the same combinatorial structure as (5.22) and (5.23).

the $\mathfrak{M}_{A,B,C}$ are constructed from BCJ gauge currents²⁴ and multiplied by KLT matrices for the slots A, B, C , so the rank- $(n-2)$ cases in (5.24) can be reduced as follows

$$\begin{aligned} \mathfrak{N}_{123|5|4} &= N_{123,5,4} = \frac{1}{s_{45}} [(k_{12} \cdot k_3)N_{12,3,5,4} + (k_1 \cdot k_2)(N_{1,23,5,4} + N_{13,2,5,4})] \\ \mathfrak{N}_{1234|6|5} &= N_{1234,6,5} = \frac{1}{s_{56}} [(k_{123} \cdot k_4)N_{123,4,6,5} + (k_{12} \cdot k_3)(N_{124,3,6,5} + N_{12,34,6,5}) \\ &\quad + (k_1 \cdot k_2)(N_{1,234,6,5} + N_{134,2,6,5} + N_{13,24,6,5} + N_{14,23,6,5})]. \end{aligned} \quad (5.25)$$

The n -point generalization involves the summation prescription of the form $a_1 a_2 \dots a_p = X \sqcup Y$ that has been introduced in section 4.3

$$\mathfrak{N}_{12\dots n-2|n|n-1} = N_{12\dots n-2,n,n-1} = \frac{1}{s_{n-1,n}} \sum_{j=2}^{n-2} (k_{12\dots j-1} \cdot k_j) \sum_{\substack{j+1, j+2, \dots, n-2 \\ =X \sqcup Y}} N_{12\dots j-1 X, j Y, n(n-1)}. \quad (5.26)$$

The right-hand sides of (5.25) and (5.26) at $n \geq 5$ can be assembled from multiparticle polarizations of maximum rank $n-3$, and the spurious poles in $s_{n-1,n}$ cancel after combining all the terms. The same strategy applies to permutations of $\mathfrak{N}_{12\dots n-2|n|n-1}$ and $\mathfrak{N}_{1|n|23\dots(n-2)(n-1)}$ in $2, 3, \dots, n-2$. Like this, the n -point amplitude representation (5.24) with manifest BCJ duality and local numerators is completely determined by multiparticle polarizations of rank $n-3$. For instance, the explicit construction of multiparticle polarizations up to rank five in section 4 is sufficient to pinpoint all the eight-point numerators in (5.24).

Note that the special footing of legs $1, n-1$ and n in (5.24) breaks the crossing symmetry even more heavily than the numerators in (5.19). Still, one can restore crossing symmetry by averaging over all choices of singling out legs $i, j, k \in \{1, 2, \dots, n\}$ instead of $1, n-1$ and n .

5.4 Relation to string-theory and gravity amplitudes

A major motivation for the construction of $(\text{YM}+F^3+F^4)$ numerators with manifest locality stems from their connection with gravitational quantities through the double copy. Following the lines of [18], the double copy of $\mathcal{A}_{\text{YM}+F^3+F^4}$ to amplitudes from higher-curvature operators $\alpha' R^2 + \alpha'^2 R^3$ can be extracted from the string-theory KLT relations [1] (also see [23, 24]): the leading α' -orders of the open-bosonic-string amplitudes

$$\mathcal{A}_{\text{bosonic}}^{\text{open}}(\sigma) = \mathcal{A}_{\text{YM}+F^3+F^4}(\sigma) + \zeta_2 \mathcal{A}_{\text{super}-F^4}(\sigma) + \mathcal{O}(\alpha'^3) \quad (5.27)$$

comprise our results for $\mathcal{A}_{\text{YM}+F^3+F^4}$ (and the aforementioned contribution from the supersymmetrizable F^4 -operator which is incompatible with the BCJ duality and can be distinguished by its coefficient ζ_2 [18]). By the interplay with the trigonometric factors in

²⁴This follows from the fact that the difference of the left- and right-hand side of (3.17) is invariant under non-linear gauge transformations (3.24).

the KLT formula, both copies of $\mathcal{A}_{\text{super-}F^4}(\sigma)$ drop out from relevant orders of the closed bosonic string [21],

$$\mathcal{M}_{\text{bosonic}}^{\text{closed}} = \sum_{\rho, \tau \in S_{n-3}} \mathcal{A}_{\text{YM}+F^3+F^4}(1, \rho, n-1, n) S(\rho|\tau)_1 \tilde{\mathcal{A}}_{\text{YM}+F^3+F^4}(1, \tau, n, n-1) + \mathcal{O}(\alpha'^3), \quad (5.28)$$

where $S(\rho|\tau)_1$ is the field-theory KLT matrix defined in (2.39) and the permutations ρ, τ act on $2, 3, \dots, n-2$. Hence, to the orders considered, the right-hand side of (5.28) describes amplitudes from the low-energy effective action of the closed bosonic string [25]

$$\mathcal{S}_{\text{bosonic}}^{\text{closed}} \sim \int d^D x \sqrt{g} \left\{ R - 2(\partial_\mu \varphi)^2 - \frac{1}{12} H^2 + \frac{\alpha'}{4} e^{-2\varphi} \left[R_{\mu\nu\lambda\rho} R^{\mu\nu\lambda\rho} - 4R_{\mu\nu} R^{\mu\nu} + R^2 \right] \right. \\ \left. + \alpha'^2 e^{-4\varphi} \left[\frac{1}{16} R^{\mu\nu}{}_{\alpha\beta} R^{\alpha\beta}{}_{\lambda\rho} R^{\lambda\rho}{}_{\mu\nu} - \frac{1}{12} R^{\mu\nu}{}_{\alpha\beta} R^{\nu\lambda}{}_{\beta\rho} R^{\lambda\mu}{}_{\rho\alpha} \right] + \mathcal{O}(\alpha'^3) \right\}, \quad (5.29)$$

where φ denotes the dilaton and $H = dB$ is the field strength of the B -field. In spite of the dilaton admixtures via $e^{-2\varphi}, e^{-4\varphi}$, the operators along with the first and second order of α' are collectively referred to as R^2 and R^3 . While the R^2 operator can be reconciled with up to sixteen supercharges [93], the R^3 operator is not supersymmetrizable [94].

Given the multitude of propagators in KLT formulae of the form (5.28), the locality properties of gravity amplitudes are more transparent in representations involving Jacobi-satisfying numerators as in (2.34). For instance, our master numerators for $(\text{YM}+F^3+F^4)$ in (5.19) and (5.24) admit a realization of the double-copy structure via

$$\mathcal{M}_{\text{GR}+R^2+R^3} = \sum_{\rho \in S_{n-2}} (a_{1\rho(23\dots n-1)}^\mu e_n^\mu) \tilde{\mathcal{A}}_{\text{YM}+F^3+F^4}(1, \rho(2, 3, \dots, n-1), n) + \mathcal{O}(\alpha'^3) \\ = \sum_{j=1}^{n-2} \sum_{\rho \in S_{n-3}} \mathfrak{N}_{1\rho(2\dots j)|n|\rho(j+1\dots n-2)n-1} \tilde{\mathcal{A}}_{\text{YM}+F^3+F^4}(1, \rho(2, \dots, j), n, \rho(j+1, \dots, n-2), n-1) \\ + \mathcal{O}(\alpha'^3), \quad (5.30)$$

where each term has the propagator structure of cubic diagrams. The subscript $\text{GR}+R^2+R^3$ is just a schematic shorthand for the amplitudes generated by the action (5.29) to the orders of α'^2 . As emphasized in [18], the α'^2 -order of (5.30) receives contribution from both single-insertions of R^3 operators and double-insertions of R^2 operators.

In $D = 4$ spacetime dimensions, the R^2 contribution to (5.29) is the topological Gauss-Bonnet term. The components at the first order in α' of (5.30) with graviton helicities are therefore guaranteed to vanish. Still, the double insertions of R^2 contribute to the α'^2 -order of graviton components in four dimensions since the prefactor of $e^{-2\varphi}$ in (5.29) allows for dilaton exchange [18].

On the right-hand side of (5.28) or (5.30), the α'^2 order receives both symmetric and asymmetric contributions: terms of the form $\mathcal{A}_{\text{YM}+F^3+F^4}|_{\alpha'} \tilde{\mathcal{A}}_{\text{YM}+F^3+F^4}|_{\alpha'}$ where both gauge-theory halves contribute a factor of α' have been carefully analyzed in $D = 4$ helicity components [18]. Our results on the α'^2 -order of $\mathcal{A}_{\text{YM}+F^3+F^4}$ and its master numerators

additionally deliver the contributions to D -dimensional amplitudes of $\text{GR} + R^2 + R^3$, where both powers of α' stem from the same gauge-theory factor. These contributions involving $\mathcal{A}_{\text{YM}+F^3+F^4}|_{\alpha'^2}$ explain²⁵ the departure of $\mathcal{M}_{\text{GR}+R^2+R^3}|_{\alpha'^2}$ from the double copy of the first α' -order $\mathcal{A}_{\text{YM}+F^3+F^4}|_{\alpha'}$ which has already been observed in certain $D = 4$ helicity components [18]. Hence, there is no need to consider higher orders from the α' -expansion of the $\sin(\frac{\pi\alpha'}{2}k_i \cdot k_j)$ terms in the string-theory KLT relations as speculated in the reference.

At the order of α' , one may extract new representations²⁶ for supersymmetrized matrix elements of R^2 from (5.30) by trading $\mathcal{A}_{\text{YM}+F^3+F^4}$ for color-ordered amplitudes of ten-dimensional SYM and their dimensional reductions. These supersymmetrizations play a key role in recent studies of divergences and duality anomalies of $\mathcal{N} = 4$ supergravity [57, 58].

6 Conclusions and outlook

In this work, we have studied various representations for tree-level amplitudes of D -dimensional gauge theories with $\alpha'F^3 + \alpha'^2F^4$ deformations. Our main results concern the emergence of the BCJ duality between color and kinematics up to the order of α'^2 which is driven by the interplay of the F^3 and F^4 -operators [18] and independent on the choice of gauge group. While the BCJ duality has originally been explained by the realization of the $\alpha'F^3 + \alpha'^2F^4$ operators from the open bosonic string, our work takes a different approach by identifying the seeds of the duality in the Berends-Giele currents of $(\text{YM}+F^3+F^4)$.

We study the Berends-Giele currents of $(\text{YM}+F^3+F^4)$ in the perturbative formalism [68–72], where non-linear gauge transformations can be mapped to reparametrizations of the scattering amplitudes [27]. First of all, these currents are used to construct manifestly cyclic amplitude representations, where the rank of the contributing currents is systematically reduced. Moreover, we pinpoint a specific non-linear gauge transformation up to the order of five on-shell legs in a single current which rearranges the naive Feynman-diagram output of the action such as to manifest the BCJ duality. Like this, we derive the BCJ relations among color-ordered amplitudes to the order of α'^2 from purely kinematic considerations. Furthermore, two kinds of explicit cubic-diagram parametrizations are given for $(\text{YM}+F^3+F^4)$ -amplitudes where the manifestly local numerators obey kinematic Jacobi relations.

Our construction is inspired by superspace kinematic factors of ten-dimensional SYM [27, 28] whose properties were inferred from the conformal-field-theory description of the pure-spinor superstring [14, 15, 37]. We identify extensions of these superspace-inspired structures to higher orders in α' and to operators F^3, F^4 that do not admit any supersymmetrization. It would be interesting to find a conformal-field-theory derivation of the local multiparticle polarizations that drive our BCJ-duality-satisfying amplitude rep-

²⁵We are grateful to Johannes Brödel for helpful discussions on this point and checking a representative four-dimensional helicity example.

²⁶Note that alternative representations with 8 supercharges on both chiral halves can be extracted from the low-energy limit of one-loop string amplitudes in $K3$ orbifolds [95, 96].

representations. One possible starting point is to combine the worldsheet description of the bosonic string with the off-shell techniques of [16]. Alternatively, it might be helpful to identify a vertex-operator origin of the CHY formulae for F^3 amplitudes [26]²⁷ along with generalizations to higher orders in α' .

A complementary approach to the $\alpha'F^3 + \alpha'^2F^4$ operators of the bosonic string is suggested by the recent double-copy description of bosonic-string amplitudes [22]: after peeling off the worldsheet integrals that are common with superstring amplitudes, an all-order family of α' -corrections of the bosonic string can be traced back to a massive gauge theory dubbed $(DF)^2 + \text{YM}$. The latter has been constructed in [97] by imposing the BCJ duality on a collection of dimension-six interactions between gauge bosons and massive scalars, and it should reproduce the $(\text{YM}+F^3+F^4)$ -amplitudes in this work upon low-energy expansion. It would be interesting to study our results from the $(DF)^2 + \text{YM}$ -perspective and to generalize them to arbitrary orders in α' by integrating out its massive modes.

Convenient and Jacobi-satisfying representations of tree-level subdiagrams are helpful for loop integrands of string- and field-theory amplitudes, see e.g. [59–62]. Our results might guide the organization of tensor structures of loop amplitudes in bosonic and heterotic string theories. This in turn could give input on loop integrands of half-maximal supergravity and their interplay with evanescent matrix elements and anomalies [54, 55, 57, 58].

Acknowledgments

We are grateful to the organizers of the PSI Winter School 2018 where this work was initiated. We would like to thank Freddy Cachazo, Sebastian Mizera, Michael David Morales Curi and Barbara Skrzypek for stimulating discussions during the Winter School and various later stages of this work. We are grateful to Johannes Brödel, Alfredo Guevara, Song He and Julio Parra-Martinez for valuable discussions. OS thanks Carlos Mafra for collaboration on related topics and comments on a draft. This research was supported in part by Perimeter Institute for Theoretical Physics. Research at Perimeter Institute is supported by the Government of Canada through the Department of Innovation, Science and Economic Development Canada and by the Province of Ontario through the Ministry of Research, Innovation and Science. The research is supported in part by the Swedish Research Council under grant 621-2014-5722 and the Knut and Alice Wallenberg Foundation under grant KAW 2013.0235.

A Properties of the cyclic building blocks

In this appendix, we prove several properties of the building block $\mathfrak{M}_{A,B,C}$ defined in (3.15) to first order in α' . These proofs are based on transversality $k_P \cdot A_P = 0$ and the truncation

²⁷Note that the CHY half-integrands \mathcal{P}_n in [26] with a puncture $z_j \in \mathbb{C}$ on the Riemann sphere for each external state $j = 1, 2, \dots, n$ and $z_{i,j} = z_i - z_j$ may be reproduced from the first order in α' of

$$\mathcal{P}_n(z_j, k_j, e_j) = \frac{a_{12\dots n-1}^\mu e_n^\mu}{z_{1,2}z_{2,3}\dots z_{n-1,n}z_{n,1}} \Big|_{(\alpha')^1} + \text{perm}(2, 3, \dots, n-1).$$

of (3.14) to the first order in α' ,

$$k_P^\lambda F_P^{\lambda\mu} = \sum_{P=XY} \left[A_X^\lambda F_Y^{\lambda\mu} + 2\alpha' F_X^{\nu\lambda} F_Y^{\nu\lambda\mu} - (X \leftrightarrow Y) \right] + \mathcal{O}(\alpha'^2). \quad (\text{A.1})$$

Moreover, we will use the generalization of (A.1) to higher mass dimension,

$$k_P^\mu F_P^{\lambda|\mu\nu} = \sum_{P=XY} \left[A_X^\mu F_Y^{\lambda|\mu\nu} + F_X^{\mu\nu} F_Y^{\mu\lambda} - (X \leftrightarrow Y) \right] + \mathcal{O}(\alpha'), \quad (\text{A.2})$$

which follows from the definition $[\nabla^\mu, \nabla^\lambda] = -\mathbb{F}^{\mu\lambda}$ and a corollary of the equations of motion, $[\nabla^\mu, [\nabla^\lambda, \mathbb{F}^{\mu\nu}]] = [\nabla^\lambda, [\nabla^\mu, \mathbb{F}^{\mu\nu}]] + [[\nabla^\mu, \nabla^\lambda], \mathbb{F}^{\mu\nu}] = -[\mathbb{F}^{\mu\lambda}, \mathbb{F}^{\mu\nu}] + \mathcal{O}(\alpha')$. By the Jacobi identity $[\nabla^\alpha, [\nabla^\mu, \nabla^\nu]] + \text{cyc}(\mu, \nu, \alpha) = 0$, the currents of higher mass dimension have the symmetries

$$F_P^{\alpha|\mu\nu} + F_P^{\mu|\nu\alpha} + F_P^{\nu|\alpha\mu} = 0. \quad (\text{A.3})$$

This can be inserted into (A.2) to find

$$k_P^\mu F_P^{\mu|\nu\lambda} = \sum_{P=XY} \left[A_X^\mu F_Y^{\mu|\nu\lambda} - 2F_X^{\mu\nu} F_Y^{\mu\lambda} - (X \leftrightarrow Y) \right] + \mathcal{O}(\alpha'). \quad (\text{A.4})$$

By virtue of (A.1), (A.2) and (A.4), one can rewrite any contraction of $F_P^{\mu\nu}$ and $F_P^{\mu|\nu\lambda}$ with the corresponding momentum k_P in terms of deconcatenations. We will always work to first order in α' , but we will split the proofs into different orders for the convenience of the reader.

A.1 Appearance in the amplitudes

The first property we wish to prove is

$$\sum_{XY=12\dots n-1} \mathfrak{M}_{X,Y,n} = s_{12\dots n-1} A_{12\dots n-1}^\mu A_n^\mu = \sum_{XY=12\dots n-1} A_{[X,Y]}^\mu A_n^\mu, \quad (\text{A.5})$$

where, as a special case of (3.15),

$$\begin{aligned} \mathfrak{M}_{X,Y,n} &= \frac{1}{2} \left(A_X^\mu F_Y^{\mu\nu} A_n^\nu + A_Y^\mu F_n^{\mu\nu} A_X^\nu + A_n^\mu F_X^{\mu\nu} A_Y^\nu \right) - 2\alpha' F_X^{\mu\nu} F_Y^{\nu\lambda} F_n^{\lambda\mu} \\ &+ \frac{\alpha'}{2} \left(F_X^{\mu|\nu\lambda} F_Y^{\nu\lambda} A_n^\mu + F_Y^{\mu|\nu\lambda} F_n^{\nu\lambda} A_X^\mu + F_n^{\mu|\nu\lambda} F_X^{\nu\lambda} A_Y^\mu \right. \\ &\quad \left. - F_X^{\mu|\nu\lambda} F_n^{\nu\lambda} A_Y^\mu - F_Y^{\mu|\nu\lambda} F_X^{\nu\lambda} A_n^\mu - F_n^{\mu|\nu\lambda} F_Y^{\nu\lambda} A_X^\mu \right) \end{aligned} \quad (\text{A.6})$$

and

$$\begin{aligned} A_{[X,Y]}^\mu &= \frac{1}{2} \left(A_Y^\mu (k_Y \cdot A_X) - A_X^\mu (k_X \cdot A_Y) + A_X^\nu F_Y^{\nu\mu} - A_Y^\nu F_X^{\nu\mu} \right) \\ &+ \alpha' \left(F_X^{\nu\lambda} F_Y^{\nu|\lambda\mu} - F_Y^{\nu\lambda} F_X^{\nu|\lambda\mu} \right). \end{aligned} \quad (\text{A.7})$$

We first focus on the zeroth order of α' . Notice how the last two terms on the first line of (A.7), when contracted with A_n^μ , exactly match the first and third terms on the first line

of (A.6). To see that the remaining terms are equal to each other, we notice that

$$\begin{aligned}
 A_Y^\mu F_n^{\mu\nu} A_X^\nu &= A_Y^\mu A_X^\nu (k_n^\mu A_n^\nu - k_n^\nu A_n^\mu) \\
 &= -A_Y^\mu A_X^\nu (k_X^\mu A_n^\nu + k_Y^\mu A_n^\mu - k_X^\nu A_n^\mu - k_Y^\nu A_n^\mu) \\
 &= (A_Y \cdot A_n)(k_Y \cdot A_X) - (A_X \cdot A_n)(k_X \cdot A_Y),
 \end{aligned} \tag{A.8}$$

where we have used momentum conservation $k_n^\mu = -k_X^\mu - k_Y^\mu$ and transversality. This matches with the missing terms at the α'^0 order of (A.7), upon contraction with A_n^μ .

We now show that the same matching occurs between the terms of order α' in both expressions. Equating them leads to

$$\begin{aligned}
 \sum_{XY=12\dots n-1} &\left\{ -2 \underbrace{F_X^{\mu\nu} F_Y^{\nu\lambda} F_n^{\lambda\mu}}_G + \frac{1}{2} \left(\underbrace{F_X^{\mu|\nu\lambda} F_Y^{\nu\lambda} A_n^\mu}_A + \underbrace{F_Y^{\mu|\nu\lambda} F_n^{\nu\lambda} A_X^\mu}_E \right. \right. \\
 &\left. \left. + \underbrace{F_n^{\mu|\nu\lambda} F_X^{\nu\lambda} A_Y^\mu}_C - \underbrace{F_X^{\mu|\nu\lambda} F_n^{\nu\lambda} A_Y^\mu}_F - \underbrace{F_Y^{\mu|\nu\lambda} F_X^{\nu\lambda} A_n^\mu}_B - \underbrace{F_n^{\mu|\nu\lambda} F_Y^{\nu\lambda} A_X^\mu}_D \right) \right\} \\
 &= \sum_{XY=12\dots n-1} (F_X^{\nu\lambda} F_Y^{\nu|\lambda\mu} A_n^\mu - F_Y^{\nu\lambda} F_X^{\nu|\lambda\mu} A_n^\mu).
 \end{aligned} \tag{A.9}$$

When using the Jacobi identity (A.3), two of the terms on the left-hand side combine to cancel exactly the two on the right-hand side:

$$\sum_{XY=12\dots n-1} \frac{1}{2} (A + B) = \sum_{XY=12\dots n-1} (-F_X^{\nu|\lambda\mu} F_Y^{\nu\lambda} A_n^\mu + F_Y^{\nu|\lambda\mu} F_X^{\nu\lambda} A_n^\mu). \tag{A.10}$$

Now we have to make sure that the remaining terms C, D, E, F and G on the left-hand side of (A.9) cancel each other. The first two can be rewritten as

$$\begin{aligned}
 \sum_{XY=12\dots n-1} \frac{1}{2} (C + D) &= F_n^{\nu|\lambda\mu} \sum_{XY=12\dots n-1} (A_X^\mu F_Y^{\nu\lambda} - A_Y^\mu F_X^{\nu\lambda}) \\
 &= -k_n^\nu F_n^{\lambda\mu} (F_{12\dots n-1}^{\mu|\nu\lambda} - k_{12\dots n-1}^\mu F_{12\dots n-1}^{\nu\lambda}) \\
 &= -k_n^\nu F_n^{\lambda\mu} F_{12\dots n-1}^{\mu|\nu\lambda},
 \end{aligned} \tag{A.11}$$

using the form $F_n^{\nu|\lambda\mu} = k_n^\nu F_n^{\lambda\mu}$ of the single-particle current as well as momentum conservation $k_{12\dots n-1}^\mu = -k_n^\mu$ and $k_n^\mu F_n^{\mu\nu} = 0$ in passing to the third line, cf. (A.2).

The other two terms combine in a similar way,

$$\begin{aligned}
 \sum_{XY=12\dots n-1} \frac{1}{2} (E + F) &= F_n^{\nu\lambda} \sum_{XY=12\dots n-1} (A_X^\mu F_Y^{\nu|\mu\lambda} - A_Y^\mu F_X^{\nu|\mu\lambda}) \\
 &= F_n^{\nu\lambda} k_{12\dots n-1}^\mu F_{12\dots n-1}^{\nu|\mu\lambda} - F_n^{\nu\lambda} \sum_{XY=12\dots n-1} (F_X^{\mu\lambda} F_Y^{\mu\nu} - F_Y^{\mu\lambda} F_X^{\mu\nu}) \\
 &= -F_n^{\nu\lambda} k_n^\mu F_{12\dots n-1}^{\nu|\mu\lambda} - 2 \sum_{XY=12\dots n-1} F_n^{\nu\lambda} F_X^{\mu\lambda} F_Y^{\mu\nu} \\
 &= \sum_{XY=12\dots n-1} \left\{ -\frac{1}{2} (C + D) + 2G \right\},
 \end{aligned} \tag{A.12}$$

where the second line follows from (A.2). In passing to the third line, we have again used momentum conservation and exploited antisymmetry $F_n^{\nu\lambda} = F_n^{[\nu\lambda]}$. Hence, the statement (A.5) is proved to first order in α' .

A.2 Integration by parts

The second property of $\mathfrak{M}_{A,B,C}$ we want to prove is the integration-by-parts identity

$$\sum_{A=XY} \mathfrak{M}_{X,Y,B} = \sum_{B=XY} \mathfrak{M}_{A,X,Y}, \quad (\text{A.13})$$

which translates into the following claim at the zeroth order in α' ,

$$\begin{aligned} & \sum_{A=XY} (A_X^\mu F_Y^{\mu\nu} A_B^\nu + A_Y^\mu F_B^{\mu\nu} A_X^\nu + A_B^\mu F_X^{\mu\nu} A_Y^\nu) \\ & - \sum_{B=XY} (A_A^\mu F_X^{\mu\nu} A_Y^\nu + A_X^\mu F_Y^{\mu\nu} A_A^\nu + A_Y^\mu F_A^{\mu\nu} A_X^\nu) = \mathcal{O}(\alpha'). \end{aligned} \quad (\text{A.14})$$

We can rewrite the second term $\sim A_X A_Y$ in the first line using the antisymmetry of $F_B^{\mu\nu}$ and the definition (3.6) of $F_A^{\mu\nu}$:

$$\begin{aligned} \sum_{A=XY} A_Y^\mu F_B^{\mu\nu} A_X^\nu &= \sum_{A=XY} \frac{1}{2} F_B^{\mu\nu} (A_Y^\mu A_X^\nu - A_Y^\nu A_X^\mu) \\ &= \frac{1}{2} F_B^{\mu\nu} F_A^{\mu\nu} - F_B^{\mu\nu} k_A^\mu A_A^\nu. \end{aligned} \quad (\text{A.15})$$

The analogous sum in the second line of (A.14) has a similar term related by $A \leftrightarrow B$,

$$- \sum_{B=XY} A_Y^\mu F_A^{\mu\nu} A_X^\nu = -\frac{1}{2} F_A^{\mu\nu} F_B^{\mu\nu} + F_A^{\mu\nu} k_B^\mu A_B^\nu, \quad (\text{A.16})$$

where $F_A^{\mu\nu} F_B^{\mu\nu}$ cancels against (A.15). For the remaining terms $F_A^{\mu\nu} k_B^\mu A_B^\nu - F_B^{\mu\nu} k_A^\mu A_A^\nu$, we apply momentum conservation $k_A^\mu + k_B^\mu = 0$ and the relation (A.1) for $k_A^\mu F_A^{\mu\nu}$,

$$\begin{aligned} \sum_{A=XY} A_Y^\mu F_B^{\mu\nu} A_X^\nu - \sum_{B=XY} A_Y^\mu F_A^{\mu\nu} A_X^\nu &= -F_A^{\mu\nu} k_A^\mu A_B^\nu + F_B^{\mu\nu} k_B^\mu A_A^\nu \\ &= - \sum_{A=XY} (A_X^\mu F_Y^{\mu\nu} A_B^\nu - A_Y^\mu F_X^{\mu\nu} A_B^\nu) + \sum_{B=XY} (A_X^\mu F_Y^{\mu\nu} A_A^\nu - A_Y^\mu F_X^{\mu\nu} A_A^\nu) \\ &\quad - 2\alpha' \sum_{A=XY} (F_X^{\mu\lambda} F_Y^{\mu|\lambda\nu} - F_Y^{\mu\lambda} F_X^{\mu|\lambda\nu}) A_B^\nu + 2\alpha' \sum_{B=XY} (F_X^{\mu\lambda} F_Y^{\mu|\lambda\nu} - F_Y^{\mu\lambda} F_X^{\mu|\lambda\nu}) A_A^\nu. \end{aligned} \quad (\text{A.17})$$

Inserting this into (A.14) and ignoring the $\mathcal{O}(\alpha')$ -term in the last line, we conclude that the property (A.13) is indeed satisfied to zeroth order in α' .

We now show that the property is still valid at the first order in α' . In doing that, we have to combine the last term of (A.17) with the $\mathcal{O}(\alpha')$ -terms in the $\mathfrak{M}_{A,B,C}$ of (A.13).

Hence, the leftover task is to prove that

$$\begin{aligned}
 0 = & \sum_{A=XY} \left((F_X^{\mu|\lambda\nu} F_Y^{\mu\lambda} - F_Y^{\mu|\lambda\nu} F_X^{\mu\lambda}) A_B^\nu - 2F_X^{\mu\nu} F_Y^{\nu\lambda} F_B^{\lambda\mu} \right. \\
 & + \frac{1}{2} \left(\underbrace{F_X^{\mu|\nu\lambda} F_Y^{\nu\lambda} A_B^\mu}_M + \underbrace{F_Y^{\mu|\nu\lambda} F_B^{\nu\lambda} A_X^\mu}_I + \underbrace{F_B^{\mu|\nu\lambda} F_X^{\nu\lambda} A_Y^\mu}_E \right. \\
 & \quad \left. \left. - \underbrace{F_X^{\mu|\nu\lambda} F_B^{\nu\lambda} A_Y^\mu}_J - \underbrace{F_Y^{\mu|\nu\lambda} F_X^{\nu\lambda} A_B^\mu}_N - \underbrace{F_B^{\mu|\nu\lambda} F_Y^{\nu\lambda} A_X^\mu}_F \right) \right) \\
 & - \sum_{B=XY} \left((F_X^{\mu|\lambda\nu} F_Y^{\mu\lambda} - F_Y^{\mu|\lambda\nu} F_X^{\mu\lambda}) A_A^\nu - 2F_A^{\mu\nu} F_X^{\nu\lambda} F_Y^{\lambda\mu} \right. \\
 & + \frac{1}{2} \left(\underbrace{F_A^{\mu|\nu\lambda} F_X^{\nu\lambda} A_Y^\mu}_G + \underbrace{F_X^{\mu|\nu\lambda} F_Y^{\nu\lambda} A_A^\mu}_C + \underbrace{F_Y^{\mu|\nu\lambda} F_A^{\nu\lambda} A_X^\mu}_K \right. \\
 & \quad \left. \left. - \underbrace{F_A^{\mu|\nu\lambda} F_Y^{\nu\lambda} A_X^\mu}_H - \underbrace{F_X^{\mu|\nu\lambda} F_A^{\nu\lambda} A_Y^\mu}_L - \underbrace{F_Y^{\mu|\nu\lambda} F_X^{\nu\lambda} A_A^\mu}_D \right) \right). \tag{A.18}
 \end{aligned}$$

Let us start by using the Jacobi identity (A.3) to rewrite the following terms:

$$\sum_{A=XY} \frac{1}{2} (M + N) = \sum_{A=XY} (F_Y^{\mu|\lambda\nu} F_X^{\mu\lambda} - F_X^{\mu|\lambda\nu} F_Y^{\mu\lambda}) A_B^\nu \tag{A.19}$$

$$\sum_{B=XY} \frac{1}{2} (C + D) = \sum_{B=XY} (F_Y^{\mu|\lambda\nu} F_X^{\mu\lambda} - F_X^{\mu|\lambda\nu} F_Y^{\mu\lambda}) A_A^\nu. \tag{A.20}$$

The right-hand sides cancel the first two terms inside the sums in (A.18) over $A = XY$ and $B = XY$. Then, using the recursive definition of $F_P^{\mu|\nu\lambda}$ in (3.9), we can write

$$\begin{aligned}
 \sum_{A=XY} \frac{1}{2} (E + F) &= F_B^{\nu|\lambda\mu} \sum_{A=XY} (A_X^\mu F_Y^{\nu\lambda} - A_Y^\mu F_X^{\nu\lambda}) \\
 &= F_B^{\nu|\lambda\mu} (k_A^\mu F_A^{\nu\lambda} - F_A^{\mu|\nu\lambda}). \tag{A.21}
 \end{aligned}$$

Since the contribution from $G + H$ takes the same form with $A \leftrightarrow B$, the terms $F_B^{\nu|\lambda\mu} F_A^{\mu|\nu\lambda}$ cancel from the combination

$$\sum_{A=XY} \frac{1}{2} (E + F) - \sum_{B=XY} \frac{1}{2} (G + H) = k_A^\mu F_A^{\nu\lambda} F_B^{\nu|\lambda\mu} - k_B^\mu F_B^{\nu\lambda} F_A^{\nu|\lambda\mu}. \tag{A.22}$$

Also, using Jacobi identity (A.3) as well as (A.2), we have

$$\begin{aligned}
\sum_{A=XY} \frac{1}{2} (\text{I} + \text{J}) &= F_B^{\nu\lambda} \sum_{A=XY} (-A_X^\mu F_Y^{\nu|\lambda\mu} + A_Y^\mu F_X^{\nu|\lambda\mu}) \\
&= F_B^{\nu\lambda} \left(k_A^\mu F_A^{\nu|\mu\lambda} - \sum_{A=XY} (F_X^{\mu\lambda} F_Y^{\mu\nu} - F_Y^{\mu\lambda} F_X^{\mu\nu}) \right) \\
&= k_A^\mu F_B^{\nu\lambda} F_A^{\nu|\mu\lambda} - 2 \sum_{A=XY} F_B^{\nu\lambda} F_X^{\mu\lambda} F_Y^{\mu\nu}
\end{aligned} \tag{A.23}$$

and using the same manipulations

$$\sum_{B=XY} \frac{1}{2} (\text{K} + \text{L}) = k_B^\mu F_A^{\nu\lambda} F_B^{\nu|\mu\lambda} - 2 \sum_{B=XY} F_A^{\nu\lambda} F_X^{\mu\lambda} F_Y^{\mu\nu}. \tag{A.24}$$

The terms of the form $k^\mu F^{\nu\lambda} F^{\nu|\mu\lambda}$ cancel between (A.22), (A.23) and (A.24) by momentum conservation $k_A + k_B = 0$. Finally, the contributions of the form $\sum_{A=XY} F_B^{\nu\lambda} F_X^{\mu\lambda} F_Y^{\mu\nu}$ cancel between (A.23), (A.24) and the leftover terms of (A.18). This concludes our proof of the integration-by-parts identity (A.13) to the order of α' .

A.3 Gauge algebra

Finally, we want to see how a non-linear gauge transformation (3.22) acts on $\mathfrak{M}_{X,Y,Z}$. To zeroth order in α' , we get

$$\begin{aligned}
\delta_\Omega \mathfrak{M}_{X,Y,Z} &= \frac{1}{2} \delta_\Omega (A_X^\mu F_Y^{\mu\nu} A_Z^\nu + \text{cyc}(X, Y, Z)) + \mathcal{O}(\alpha') \\
&= \frac{1}{2} \left(k_X^\mu \Omega_X F_Y^{\mu\nu} A_Z^\nu - \sum_{X=AB} (A_A^\mu \Omega_B - A_B^\mu \Omega_A) F_Y^{\mu\nu} A_Z^\nu \right. \\
&\quad - \sum_{Y=AB} (F_A^{\mu\nu} \Omega_B - F_B^{\mu\nu} \Omega_A) A_X^\mu A_Z^\nu + A_X^\mu F_Y^{\mu\nu} k_Z^\nu \Omega_Z \\
&\quad \left. - \sum_{Z=AB} (A_A^\nu \Omega_B - A_B^\nu \Omega_A) A_X^\mu F_Y^{\mu\nu} + \text{cyc}(X, Y, Z) \right) + \mathcal{O}(\alpha').
\end{aligned} \tag{A.25}$$

Let us look at the terms which are not inside a sum. We can start by grouping all the ones with the same Ω . coefficient, and use momentum conservation $k_X^\mu + k_Y^\mu + k_Z^\mu = 0$:

$$\begin{aligned}
k_X^\mu \Omega_X F_Y^{\mu\nu} A_Z^\nu + k_X^\nu \Omega_X F_Z^{\mu\nu} A_Y^\mu + \text{cyc}(X, Y, Z) \\
= -\Omega_X (F_Y^{\mu\nu} A_Z^\nu (k_Y^\mu + k_Z^\mu) + A_Y^\mu F_Z^{\mu\nu} (k_Y^\nu + k_Z^\nu)) + \text{cyc}(X, Y, Z).
\end{aligned} \tag{A.26}$$

We then rewrite these four terms via

$$\begin{aligned}
-\Omega_X k_Y^\mu F_Y^{\mu\nu} A_Z^\nu &= -\Omega_X \sum_{Y=AB} (A_A^\mu F_B^{\mu\nu} - A_B^\mu F_A^{\mu\nu}) A_Z^\nu + \mathcal{O}(\alpha') \\
-\Omega_X F_Y^{\mu\nu} k_Z^\mu A_Z^\nu &= -\frac{1}{2} \Omega_X F_Y^{\mu\nu} (k_Z^\mu A_Z^\nu - k_Z^\nu A_Z^\mu) \\
&= -\frac{1}{2} \Omega_X F_Y^{\mu\nu} F_Z^{\mu\nu} - \Omega_X F_Y^{\mu\nu} \sum_{Z=AB} A_A^\mu A_B^\nu
\end{aligned} \tag{A.27}$$

and the same identities with $(Y \leftrightarrow Z)$. In the first line, we rewrote $k_Y^\mu F_Y^{\mu\nu}$ using the zeroth order in α' of (A.1). The last two lines of (A.27) are based on the antisymmetry of $F_Y^{\mu\nu}$ and the definition (3.6) of $F_Z^{\mu\nu}$. Notice that $F_Y^{\mu\nu} F_Z^{\mu\nu}$ cancels in the antisymmetrization w.r.t. $Y \leftrightarrow Z$ in (A.26). Hence, all the leftover terms in (A.25) involve a sum over deconcatenations, either $\sum_{X=AB}$ or one of $(X \leftrightarrow Y, Z)$. We collect all the expressions from the cyclic permutations in (A.25) where the sum is $\sum_{X=AB}$

$$\begin{aligned} \delta_\Omega \mathfrak{M}_{X,Y,Z} = & \frac{1}{2} \sum_{X=AB} \left((\Omega_A A_B^\mu - \Omega_B A_A^\mu) F_Y^{\mu\nu} A_Z^\nu + A_Z^\mu (\Omega_A F_B^{\mu\nu} - \Omega_B F_A^{\mu\nu}) A_Y^\nu \right. \\ & + A_Y^\mu F_Z^{\mu\nu} (\Omega_A A_B^\nu - \Omega_B A_A^\nu) + \Omega_Y [(A_A^\mu F_B^{\mu\nu} - A_B^\mu F_A^{\mu\nu}) A_Z^\nu - F_Z^{\mu\nu} A_A^\mu A_B^\nu] \\ & \left. - \Omega_Z [(A_A^\mu F_B^{\mu\nu} - A_B^\mu F_A^{\mu\nu}) A_Y^\nu - F_Y^{\mu\nu} A_A^\mu A_B^\nu] \right) + \text{cyc}(X, Y, Z) + \mathcal{O}(\alpha'). \end{aligned} \quad (\text{A.28})$$

It turns out that the coefficient of each of the Ω 's inside the above sum can be identified as some $\mathfrak{M}_{P,Q,R}$ with various combinations of the three words:

$$\begin{aligned} \delta_\Omega \mathfrak{M}_{X,Y,Z} = & \sum_{X=AB} \left(\Omega_A \mathfrak{M}_{B,Y,Z} - \Omega_B \mathfrak{M}_{A,Y,Z} + \Omega_Y \mathfrak{M}_{A,B,Z} - \Omega_Z \mathfrak{M}_{Y,A,B} \right) \\ & + \text{cyc}(X, Y, Z) + \mathcal{O}(\alpha'). \end{aligned} \quad (\text{A.29})$$

The object inside the sum over $X = AB$ is totally antisymmetric in A, B, Y, Z and can be identified as $\Omega_{A,B,C,D}$ as defined in (3.24). Hence, the zeroth order of the gauge transformation (A.25) can be written as

$$\delta_\Omega \mathfrak{M}_{X,Y,Z} = \sum_{X=AB} \Omega_{A,B,Y,Z} + \sum_{Y=AB} \Omega_{A,B,Z,X} + \sum_{Z=AB} \Omega_{A,B,X,Y} + \mathcal{O}(\alpha'). \quad (\text{A.30})$$

We now want to extend the proof of (A.30) to the first order in α' . First of all, terms of $\mathcal{O}(\alpha')$ have been neglected when inserting (A.1) into the first term of (A.27). Therefore, we carry forward the following terms in $\delta_\Omega \mathfrak{M}_{X,Y,Z}$,

$$\begin{aligned} \Omega_X \sum_{Z=AB} (F_A^{\mu\lambda} F_B^{\mu|\lambda\nu} - F_B^{\mu\lambda} F_A^{\mu|\lambda\nu}) A_Y^\nu \pm \text{perm}(X, Y, Z) \\ = -\Omega_Z \sum_{X=AB} (F_A^{\mu\lambda} F_B^{\mu|\lambda\nu} - F_B^{\mu\lambda} F_A^{\mu|\lambda\nu}) A_Y^\nu \\ + \Omega_Y \sum_{X=AB} (F_A^{\mu\lambda} F_B^{\mu|\lambda\nu} - F_B^{\mu\lambda} F_A^{\mu|\lambda\nu}) A_Z^\nu + \text{cyc}(X, Y, Z), \end{aligned} \quad (\text{A.31})$$

where we have spelt out all the terms of the same form $\sum_{X=AB}$ as in (A.28). This needs to be combined with the gauge variation of the $\mathcal{O}(\alpha')$ terms in the definition (3.15) of $\mathfrak{M}_{X,Y,Z}$:

$$\begin{aligned} L = & -2\delta_\Omega (F_X^{\mu\nu} F_Y^{\nu\lambda} F_Z^{\lambda\mu}) \\ = & 2 \sum_{X=AB} (F_A^{\mu\nu} \Omega_B - F_B^{\mu\nu} \Omega_A) F_Y^{\nu\lambda} F_Z^{\lambda\mu} + \text{cyc}(X, Y, Z) \end{aligned}$$

$$\begin{aligned}
 G &= \frac{1}{2} \delta_\Omega (F_X^{\mu|\nu\lambda} F_Y^{\nu\lambda} A_Z^\mu) \pm \text{perm}(X, Y, Z) \\
 &= \frac{1}{2} \left(\sum_{X=AB} (F_A^{\mu|\nu\lambda} \Omega_B - F_B^{\mu|\nu\lambda} \Omega_A) F_Y^{\nu\lambda} A_Z^\mu \right. \\
 &\quad - \sum_{Y=AB} (F_A^{\nu\lambda} \Omega_B - F_B^{\nu\lambda} \Omega_A) F_X^{\mu|\nu\lambda} A_Z^\mu + \Omega_Z k_Z^\mu F_X^{\mu|\nu\lambda} F_Y^{\nu\lambda} \\
 &\quad \left. - \sum_{Z=AB} (A_A^\mu \Omega_B - A_B^\mu \Omega_A) F_X^{\mu|\nu\lambda} F_Y^{\nu\lambda} \pm \text{perm}(X, Y, Z) \right). \tag{A.32}
 \end{aligned}$$

The only term in (A.32) which is not yet in the form of a deconcatenation sum will now be rewritten via momentum conservation $k_X^\mu + k_Y^\mu + k_Z^\mu = 0$:

$$\Omega_Z k_Z^\mu F_X^{\mu|\nu\lambda} F_Y^{\nu\lambda} = \underbrace{-\Omega_Z k_X^\mu F_X^{\mu|\nu\lambda} F_Y^{\nu\lambda}}_C - \underbrace{\Omega_Z k_Y^\mu F_X^{\mu|\nu\lambda} F_Y^{\nu\lambda}}_D. \tag{A.33}$$

The first term calls for the relation (A.2),

$$C = -2\Omega_Z \sum_{X=AB} (A_A^\mu F_B^{\nu|\mu\lambda} - A_B^\mu F_A^{\nu|\mu\lambda} + F_A^{\mu\lambda} F_B^{\mu\nu} - F_B^{\mu\lambda} F_A^{\mu\nu}) F_Y^{\nu\lambda}, \tag{A.34}$$

which we combined with the Jacobi identity (A.3). In the other term we use the definition (3.9) of the currents $F_Y^{\mu|\nu\lambda}$,

$$D = -\Omega_Z F_X^{\mu|\nu\lambda} \left(F_Y^{\mu|\nu\lambda} + \sum_{Y=AB} (A_A^\mu F_B^{\nu\lambda} - A_B^\mu F_A^{\nu\lambda}) \right). \tag{A.35}$$

The first term $F_X^{\mu|\nu\lambda} F_Y^{\mu|\nu\lambda}$ cancels under the antisymmetrization w.r.t. X, Y, Z of (A.32),

$$D \pm \text{perm}(X, Y, Z) = -\Omega_Y \sum_{X=AB} (A_A^\mu F_B^{\nu\lambda} - A_B^\mu F_A^{\nu\lambda}) F_Z^{\mu|\nu\lambda} \pm \text{perm}(X, Y, Z), \tag{A.36}$$

such that all the terms in the quantity G have been expressed via deconcatenation sums:

$$\begin{aligned}
 G &= \frac{1}{2} \sum_{X=AB} \left(- (F_A^{\mu|\nu\lambda} \Omega_B - F_B^{\mu|\nu\lambda} \Omega_A) F^{\nu\lambda} A_Z^\mu \right. \\
 &\quad - (F_A^{\nu\lambda} \Omega_B - F_B^{\nu\lambda} \Omega_A) F_Z^{\mu|\nu\lambda} A_Y^\mu - 2\Omega_Z (A_A^\mu F_B^{\nu|\mu\lambda} - A_B^\mu F_A^{\nu|\mu\lambda}) F_Y^{\nu\lambda} \\
 &\quad - 2\Omega_Z (F_A^{\mu\lambda} F_B^{\mu\nu} - F_B^{\mu\lambda} F_A^{\mu\nu}) F_Y^{\nu\lambda} - \Omega_Y (A_A^\mu F_B^{\nu\lambda} - A_B^\mu F_A^{\nu\lambda}) F_Z^{\mu|\nu\lambda} \\
 &\quad \left. - (A_A^\mu \Omega_B - A_B^\mu \Omega_A) F_Y^{\mu|\nu\lambda} F_Z^{\nu\lambda} \pm \text{perm}(X, Y, Z) \right). \tag{A.37}
 \end{aligned}$$

Once we convert the permutation sum in (A.37) to a cyclic one,

$$f(X, Y, Z) + \text{perm}(X, Y, Z) = f(X, Y, Z) - f(X, Z, Y) + \text{cyc}(X, Y, Z), \tag{A.38}$$

the result for G is perfectly lined up with (A.31) and the expression for L in (A.32). Hence, the overall $\mathcal{O}(\alpha')$ contribution to the gauge variation of $\mathfrak{M}_{X,Y,Z}$ in (3.15) reads

$$\begin{aligned}
 \delta_\Omega \mathfrak{M}_{X,Y,Z} |_{\alpha'^1} = & \frac{1}{2} \sum_{X=AB} \left\{ 2(F_A^{\mu\nu} \Omega_B - F_B^{\mu\nu} \Omega_A) F_Y^{\nu\lambda} F_Z^{\lambda\mu} \right. \\
 & - \frac{1}{2} (F_A^{\mu|\nu\lambda} \Omega_B - F_B^{\mu|\nu\lambda} \Omega_A) F_Y^{\nu\lambda} A_Z^\mu + \frac{1}{2} (F_A^{\mu|\nu\lambda} \Omega_B - F_B^{\mu|\nu\lambda} \Omega_A) F_Z^{\nu\lambda} A_Y^\mu \\
 & - \frac{1}{2} (F_A^{\nu\lambda} \Omega_B - F_B^{\nu\lambda} \Omega_A) F_Z^{\mu|\nu\lambda} A_Y^\mu + \frac{1}{2} (F_A^{\nu\lambda} \Omega_B - F_B^{\nu\lambda} \Omega_A) F_Y^{\mu|\nu\lambda} A_Z^\mu \\
 & - \frac{1}{2} (A_A^\mu \Omega_B - A_B^\mu \Omega_A) F_Y^{\mu|\nu\lambda} F_Z^{\nu\lambda} + \frac{1}{2} (A_A^\mu \Omega_B - A_B^\mu \Omega_A) F_Z^{\mu|\nu\lambda} F_Y^{\nu\lambda} \\
 & + \Omega_Y \left[(F_A^{\mu\lambda} F_B^{\mu|\lambda\nu} - F_B^{\mu\lambda} F_A^{\mu|\lambda\nu}) A_Z^\nu - \frac{1}{2} (A_A^\mu F_B^{\nu\lambda} - A_B^\mu F_A^{\nu\lambda}) F_Z^{\mu|\nu\lambda} \right. \\
 & \quad \left. + (A_A^\mu F_B^{\nu|\mu\lambda} - A_B^\mu F_A^{\nu|\mu\lambda}) F_Z^{\nu\lambda} + (F_A^{\mu\lambda} F_B^{\mu\nu} - F_B^{\mu\lambda} F_A^{\mu\nu}) F_Z^{\nu\lambda} \right] \\
 & + \Omega_Z \left[- (F_A^{\mu\lambda} F_B^{\mu|\lambda\nu} - F_B^{\mu\lambda} F_A^{\mu|\lambda\nu}) A_Y^\nu + \frac{1}{2} (A_A^\mu F_B^{\nu\lambda} - A_B^\mu F_A^{\nu\lambda}) F_Y^{\mu|\nu\lambda} \right. \\
 & \quad \left. - (A_A^\mu F_B^{\nu|\mu\lambda} - A_B^\mu F_A^{\nu|\mu\lambda}) F_Y^{\nu\lambda} - (F_A^{\mu\lambda} F_B^{\mu\nu} - F_B^{\mu\lambda} F_A^{\mu\nu}) F_Y^{\nu\lambda} \right] \Big\} \\
 & + \text{cyc}(X, Y, Z).
 \end{aligned} \tag{A.39}$$

The coefficients of Ω_A , Ω_B , Ω_X and Ω_Y are identified as the $\mathcal{O}(\alpha')$ terms of $\mathfrak{M}_{A,B,C}$. Hence, with the definition (3.24) of $\Omega_{A,B,Y,Z}$, the expression in (A.39) condenses to

$$\delta_\Omega \mathfrak{M}_{X,Y,Z} |_{\alpha'^1} = \sum_{X=AB} \Omega_{A,B,Y,Z} |_{\alpha'^1} + \text{cyc}(X, Y, Z) \tag{A.40}$$

and confirms (A.30) to also hold at the first order in α' .

B The explicit form of gauge scalars towards BCJ gauge

B.1 The local building block h_{12345}

In this appendix, we spell out two representations of the local rank-five scalar h_{12345} that arises in the redefinition (4.21) towards the multiparticle polarization a_{12345}^μ . The scalar h_{12345} can be expressed in terms of the local building blocks $N_{X,Y,Z}$ defined in (5.22) which are composed from multiparticle polarizations at rank ≤ 3 ,

$$\begin{aligned}
 h_{12345} = & \frac{1}{10} [N_{123,4,5} + N_{453,2,1} + N_{12,3,45}] + \frac{1}{60} [N_{1,2,3} (k_{123} \cdot a_{45}) - N_{3,4,5} (k_{345} \cdot a_{12})] \\
 & + \frac{1}{240} \{ (k_{1234} \cdot a_5) [2N_{12,3,4} + N_{13,2,4} - N_{14,2,3} - N_{23,1,4} + N_{24,1,3} + 2N_{34,1,2}] \\
 & - (k_{1235} \cdot a_4) [2N_{12,3,5} + N_{13,2,5} - N_{15,2,3} - N_{23,1,5} + N_{25,1,3} + 2N_{35,1,2}] \\
 & - (k_{2345} \cdot a_1) [2N_{54,3,2} + N_{53,4,2} - N_{52,4,3} - N_{43,5,2} + N_{42,5,3} + 2N_{32,5,4}] \\
 & + (k_{1345} \cdot a_2) [2N_{54,3,1} + N_{53,4,1} - N_{51,4,3} - N_{43,5,1} + N_{41,5,3} + 2N_{31,5,4}] \Big\}
 \end{aligned}$$

$$\begin{aligned}
 & -\frac{1}{240} (k_{1245} \cdot a_3) [N_{1,4,5} (k_{145} \cdot a_2) - N_{2,4,5} (k_{245} \cdot a_1) - N_{1,2,4} (k_{124} \cdot a_5) + N_{1,2,5} (k_{125} \cdot a_4)] \\
 & + \frac{1}{40} (k_{1245} \cdot a_3) [N_{12,4,5} - N_{45,1,2}].
 \end{aligned} \tag{B.1}$$

A more compact expression can be attained by additionally employing lower-rank scalars h_{ijk} and h_{ijkl} ,

$$\begin{aligned}
 h_{12345} &= \frac{1}{10} [N_{123,4,5} + N_{453,2,1} + N_{12,3,45}] + \frac{1}{40} (k_{1245} \cdot a_3) [N_{12,4,5} + N_{45,2,1}] \\
 & + \frac{1}{10} [h_{1234} (k_{1234} \cdot a_5) - h_{1235} (k_{1235} \cdot a_4) - h_{5432} (k_{2345} \cdot a_1) + h_{5431} (k_{1345} \cdot a_2)] \\
 & + \frac{1}{40} (k_{1245} \cdot a_3) [h_{452} (k_{245} \cdot a_1) - h_{451} (k_{145} \cdot a_2) + h_{124} (k_{124} \cdot a_5) - h_{125} (k_{125} \cdot a_4)] \\
 & + \frac{1}{10} [h_{123} (k_{123} \cdot a_{45}) - h_{453} (k_{345} \cdot a_{12})].
 \end{aligned} \tag{B.2}$$

B.2 An alternative expression for H_{1234}

The gauge scalar H_{1234} in (5.6) which relates Berends-Giele currents in Lorenz and BCJ gauge via (5.4) admits the following alternatively representation

$$\begin{aligned}
 s_{1234} H_{1234} &= \frac{1}{48} (k_{123} \cdot a_4) \mathfrak{M}_{1,2,3} \left(\frac{3}{s_{123}} \left(\frac{1}{s_{12}} - \frac{1}{s_{23}} \right) + \frac{1}{s_{234}} \left(\frac{1}{s_{34}} - \frac{1}{s_{23}} \right) + \frac{2}{s_{12}s_{34}} \right) \\
 & + \frac{1}{48} (k_{234} \cdot a_1) \mathfrak{M}_{2,3,4} \left(\frac{1}{s_{123}} \left(\frac{1}{s_{12}} - \frac{1}{s_{23}} \right) + \frac{3}{s_{234}} \left(\frac{1}{s_{34}} - \frac{1}{s_{23}} \right) + \frac{2}{s_{12}s_{34}} \right) \\
 & + \frac{1}{48} (k_{134} \cdot a_2) \mathfrak{M}_{1,3,4} \left(\frac{1}{s_{123}} \left(\frac{1}{s_{23}} - \frac{1}{s_{12}} \right) + \frac{1}{s_{234}} \left(\frac{1}{s_{34}} - \frac{1}{s_{23}} \right) - \frac{2}{s_{12}s_{34}} \right) \\
 & + \frac{1}{48} (k_{124} \cdot a_3) \mathfrak{M}_{1,2,4} \left(\frac{1}{s_{123}} \left(\frac{1}{s_{12}} - \frac{1}{s_{23}} \right) + \frac{1}{s_{234}} \left(\frac{1}{s_{23}} - \frac{1}{s_{34}} \right) - \frac{2}{s_{12}s_{34}} \right) \\
 & + \frac{1}{8} s_{12} \mathfrak{M}_{12,3,4} \left(-\frac{1}{s_{123}s_{12}} + \frac{1}{s_{234}s_{34}} + \frac{2}{s_{12}s_{34}} \right) \\
 & + \frac{1}{8} s_{34} \mathfrak{M}_{34,1,2} \left(-\frac{1}{s_{123}s_{12}} + \frac{1}{s_{234}s_{34}} - \frac{2}{s_{12}s_{34}} \right) \\
 & - \frac{1}{8} \mathfrak{M}_{32,1,4} \left(\frac{1}{s_{123}} - \frac{1}{s_{234}} \right) - \frac{1}{8} s_{14} \mathfrak{M}_{14,3,2} \left(\frac{1}{s_{123}s_{23}} - \frac{1}{s_{234}s_{23}} \right).
 \end{aligned} \tag{B.3}$$

B.3 The Berends-Giele version H_{12345}

In this appendix, we spell out the rank-five generalization of the gauge scalars H_P in (5.5) that relate Berends-Giele currents in Lorenz and BCJ gauge via (5.7). M

$$\begin{aligned}
 s_{12345} H_{12345} &= \frac{1}{s_{1234}s_{234}} \left(\frac{h_{23415}}{s_{23}} - \frac{h_{34215}}{s_{34}} \right) + \frac{1}{s_{1234}s_{123}} \left(\frac{h_{23145}}{s_{23}} - \frac{h_{12345}}{s_{12}} \right) - \frac{h_{12345} - h_{12435}}{s_{1234}s_{12}s_{34}} \\
 & + \frac{N_{123,4,5}}{5s_{12}s_{45}} \left(\frac{3}{2s_{123}} + \frac{1}{s_{345}} \right) - \frac{1}{5s_{123}s_{23}s_{45}} \left(\frac{3}{2} N_{231,4,5} + N_{541,3,2} \right)
 \end{aligned}$$

$$\begin{aligned}
 & + (k_{1234} \cdot a_5) \frac{N_{34,1,2} - N_{12,3,4}}{4s_{12}s_{34}} \left(\frac{1}{2s_{1234}} + \frac{1}{5s_{345}} \right) + \frac{1}{5s_{123}s_{45}} \left(\frac{N_{23,1,45}}{s_{23}} - \frac{N_{12,3,45}}{s_{12}} \right) \\
 & + (k_{1234} \cdot a_5) h_{1234} \left(\frac{1}{5s_{12}s_{45}} \left(\frac{3}{2s_{123}} + \frac{1}{s_{345}} \right) + \frac{1}{2s_{1234}} \left(\frac{1}{s_{123}s_{12}} - \frac{1}{s_{234}s_{34}} \right) \right) \\
 & + (k_{1235} \cdot a_4) \frac{h_{2135}}{5s_{12}} \left(\frac{3}{2s_{123}s_{45}} + \frac{1}{s_{345}} \left(\frac{1}{s_{45}} - \frac{1}{s_{34}} \right) \right) \\
 & + (k_{1234} \cdot a_5) \frac{h_{3214}}{2s_{23}} \left(\frac{3}{5s_{123}s_{45}} + \frac{1}{s_{1234}} \left(\frac{1}{s_{123}} - \frac{1}{s_{234}} \right) \right) \\
 & + (k_{123} \cdot a_{45}) \frac{h_{123}}{5s_{45}} \left(\frac{3}{2s_{123}} \left(\frac{1}{s_{12}} - \frac{1}{s_{23}} \right) + \frac{1}{s_{345}s_{12}} \right) \\
 & + (k_{145} \cdot a_{23}) \frac{h_{415}}{5s_{123}s_{23}s_{45}} + (k_{1235} \cdot a_4) \frac{3h_{2315}}{10s_{123}s_{23}s_{45}} + (k_{1245} \cdot a_3) \frac{h_{5412}}{5s_{123}s_{23}s_{45}} \\
 & - (k_{1234} \cdot a_5) \left[(k_{123} \cdot a_4) \frac{h_{123}}{4} \left(\frac{1}{s_{12}s_{34}} \left(\frac{1}{2s_{1234}} + \frac{1}{5s_{345}} \right) + \frac{1}{s_{1234}s_{123}} \left(\frac{1}{s_{12}} - \frac{1}{s_{23}} \right) \right) \right. \\
 & \quad + (k_{234} \cdot a_1) \frac{h_{342}}{4} \left(\frac{1}{s_{12}s_{34}} \left(\frac{1}{2s_{1234}} + \frac{1}{5s_{345}} \right) + \frac{1}{s_{1234}s_{234}} \left(\frac{1}{s_{34}} - \frac{1}{s_{23}} \right) \right) \\
 & \quad \left. - \frac{(k_{124} \cdot a_3)h_{124} + (k_{134} \cdot a_2)h_{341}}{4s_{12}s_{34}} \left(\frac{1}{2s_{1234}} + \frac{1}{5s_{345}} \right) \right] \\
 & - \frac{(k_{1245} \cdot a_3)}{20s_{123}s_{12}s_{45}} \left(N_{12,4,5} - N_{45,1,2} + (k_{124} \cdot a_5)h_{124} - (k_{125} \cdot a_4)h_{125} \right. \\
 & \quad \left. - (k_{145} \cdot a_2)h_{451} + (k_{245} \cdot a_1)h_{452} \right) + (12345 \rightarrow 54321). \tag{B.4}
 \end{aligned}$$

C Deriving a BCJ representation for (YM+ F^3 + F^4) amplitudes

This appendix is dedicated to the proof of (5.24), an n -point amplitude representation for (YM+ F^3 + F^4) with manifest BCJ duality. In comparison to (5.19), the local master numerators are built from multiparticle polarizations of lower rank. We start by deriving (5.24) in the color-ordering $\sigma = 1, 2, \dots, n$ from the amplitude representation in (3.16): by non-linear gauge invariance, one can transform the Berends-Giele currents from Lorenz gauge to BCJ gauge, $\mathfrak{M}_{1P,n-1Q,n} \rightarrow \sum_{\beta,\pi} \Phi(P|\beta)_1 \Phi(Q|\pi)_{n-1} N_{1\beta,n-1\pi,n}$ and rewrite (3.16) as

$$\begin{aligned}
 \mathcal{A}_{\text{YM}+F^3+F^4}(1, 2, 3, \dots, n-1, n) &= \sum_{j=1}^{n-2} (-1)^{n-j} \mathfrak{M}_{12\dots j, n-1n-2\dots j+1, n} \\
 &= \sum_{j=1}^{n-2} (-1)^{n-j} \sum_{\beta \in S_{j-1}} \sum_{\pi \in S_{n-2-j}} \Phi(23\dots j|\beta)_1 \Phi(n-2\dots j+1|\pi)_{n-1} N_{1\beta, n-1\pi, n} \\
 &= - \sum_{j=1}^{n-2} \sum_{\beta \in S_{j-1}} \sum_{\pi \in S_{n-2-j}} \phi_{12\dots j|1\beta} \phi_{n-1, n-2\dots j+1|n-1\pi} \mathfrak{N}_{1, \beta|n|\tilde{\pi}, n-1}, \tag{C.1}
 \end{aligned}$$

where β and π are understood to act on $2, 3, \dots, j$ and $n-2, n-3, \dots, j+1$, respectively. In passing to the last line, we have converted $N_{1\beta, n-1\pi, n} = -N_{1\beta, n, n-1\pi} = (-1)^{n-j-1} \mathfrak{N}_{1, \beta|n|\tilde{\pi}, n-1}$ via (5.23), where $\tilde{\pi} = \pi(j+1), \dots, \pi(n-2)$ is the reversal of $\pi = \pi(n-2), \pi(n-3) \dots \pi(j+1)$.

Now, it remains to check that the coefficients of the \mathfrak{N}_{\dots} are identical in (5.24) and (C.1). The coefficients in (5.24) can be rewritten using the Berends-Giele recursion (2.40) and (2.41) for doubly-partial amplitudes [63],

$$\begin{aligned}
 & m(1, 2, \dots, n-1, n|1, \rho(2, 3, \dots, j), n, \rho(j+1, \dots, n-2), n-1) \\
 &= s_{12\dots n-1} \phi_{12\dots n-1|\rho(j+1)\dots\rho(n-2), n-1, 1, \rho(2)\dots\rho(j)} \\
 &= \sum_{\substack{XY=12\dots n-1 \\ AB=\rho(j+1)\dots\rho(n-2), n-1, 1, \rho(2)\dots\rho(j)}} (\phi_{X|A}\phi_{Y|B} - \phi_{Y|A}\phi_{X|B}) \tag{C.2} \\
 &= -\phi_{123\dots j|1\rho(2)\rho(3)\dots\rho(j)} \phi_{j+1\dots n-2, n-1|\rho(j+1)\dots\rho(n-2)n-1} \\
 &= -\phi_{123\dots j|1\rho(2)\rho(3)\dots\rho(j)} \phi_{n-1, n-2\dots j+1|n-1\rho(n-2)\dots\rho(j+1)}.
 \end{aligned}$$

In the third step, we have used that any deconcatenation $12\dots n-1 = XY$ will have 1 and $n-1$ in different words X and Y , such that $\rho(j+1)\dots\rho(n-2), n-1, 1, \rho(2)\dots\rho(j) = AB$ must also be deconcatenated in a manner where $n-1$ and 1 are separated. One would otherwise get a vanishing current $\phi_{P|Q}$ where P is not a permutation of Q . The only admissible deconcatenation in (C.2) is $A = \rho(j+1)\dots\rho(n-2), n-1$ and $B = 1, \rho(2)\dots\rho(j)$. After combining (C.2) with (5.24), the leftover task is to demonstrate the matching of the permutation sums

$$\begin{aligned}
 & \sum_{\rho \in S_{n-3}} \mathfrak{N}_{1\rho(23\dots j)|n|\rho(j+1\dots n-2)n-1} \phi_{123\dots j|1\rho(2)\rho(3)\dots\rho(j)} \phi_{n-1, n-2\dots j+1|n-1\rho(n-2)\dots\rho(j+1)} \\
 &= \sum_{\beta \in S_{j-1}} \sum_{\pi \in S_{n-2-j}} \phi_{12\dots j|1\beta} \phi_{n-1, n-2\dots j+1|n-1\pi} \mathfrak{N}_{1, \beta|n|\tilde{\pi}, n-1}. \tag{C.3}
 \end{aligned}$$

We exploit once more that $\phi_{P|Q}$ vanishes unless P is a permutation of Q . Hence, the first line can only contribute via permutations $\rho \in S_{n-3}$ that do not mix the sets $2, 3, \dots, j$ and $j+1, \dots, n-2$, i.e. that factorize into $\beta \in S_{j-1}$ acting on $2, 3, \dots, j$ and $\pi \in S_{n-2-j}$ acting on $n-2, \dots, j+1$ as seen in the second line. Finally, the relative flip between the permutation π in the second current and $\tilde{\pi}$ in the \mathfrak{N}_{\dots} in the second line of (C.3) ties in with the analogous reversal of $\rho(j+1), \rho(j+2), \dots, \rho(n-2)$ in the first line.

So far, we have shown that (5.24) and (C.1) agree when $\sigma = 1, 2, \dots, n$. Given that the special footing of legs $1, n-1, n$ in the master numerators $\mathfrak{N}_{1, \beta|n|\tilde{\pi}, n-1}$ is inert under permutations of $2, 3, \dots, n-2$, one can literally repeat the above steps for $\sigma = 1, \tau(2, 3, \dots, n-2), n-1, n$ with $\tau \in S_{n-3}$. Like this, (5.24) is demonstrated to hold for a BCJ basis of $\mathcal{A}_{\text{YM}+F^3+F^4}(\sigma)$. For more general choices of σ , both sides of (5.24) obey the same BCJ relations, so the arguments of the proof extend to any $\sigma \in S_n$.

Open Access. This article is distributed under the terms of the Creative Commons Attribution License (CC-BY 4.0), which permits any use, distribution and reproduction in any medium, provided the original author(s) and source are credited.

References

- [1] H. Kawai, D.C. Lewellen and S.H.H. Tye, *A Relation Between Tree Amplitudes of Closed and Open Strings*, *Nucl. Phys. B* **269** (1986) 1 [[INSPIRE](#)].
- [2] Z. Bern, J.J.M. Carrasco and H. Johansson, *New Relations for Gauge-Theory Amplitudes*, *Phys. Rev. D* **78** (2008) 085011 [[arXiv:0805.3993](#)] [[INSPIRE](#)].
- [3] Z. Bern, J.J.M. Carrasco and H. Johansson, *Perturbative Quantum Gravity as a Double Copy of Gauge Theory*, *Phys. Rev. Lett.* **105** (2010) 061602 [[arXiv:1004.0476](#)] [[INSPIRE](#)].
- [4] Z. Bern, J.J. Carrasco, W.-M. Chen, H. Johansson and R. Roiban, *Gravity Amplitudes as Generalized Double Copies of Gauge-Theory Amplitudes*, *Phys. Rev. Lett.* **118** (2017) 181602 [[arXiv:1701.02519](#)] [[INSPIRE](#)].
- [5] Z. Bern, J.J.M. Carrasco, L.J. Dixon, H. Johansson and R. Roiban, *Simplifying Multiloop Integrands and Ultraviolet Divergences of Gauge Theory and Gravity Amplitudes*, *Phys. Rev. D* **85** (2012) 105014 [[arXiv:1201.5366](#)] [[INSPIRE](#)].
- [6] Z. Bern, S. Davies, T. Dennen and Y.-t. Huang, *Absence of Three-Loop Four-Point Divergences in $N = 4$ Supergravity*, *Phys. Rev. Lett.* **108** (2012) 201301 [[arXiv:1202.3423](#)] [[INSPIRE](#)].
- [7] Z. Bern, S. Davies, T. Dennen, A.V. Smirnov and V.A. Smirnov, *Ultraviolet Properties of $N = 4$ Supergravity at Four Loops*, *Phys. Rev. Lett.* **111** (2013) 231302 [[arXiv:1309.2498](#)] [[INSPIRE](#)].
- [8] Z. Bern, S. Davies and T. Dennen, *Enhanced ultraviolet cancellations in $\mathcal{N} = 5$ supergravity at four loops*, *Phys. Rev. D* **90** (2014) 105011 [[arXiv:1409.3089](#)] [[INSPIRE](#)].
- [9] Z. Bern, J.J.M. Carrasco, W.-M. Chen, H. Johansson, R. Roiban and M. Zeng, *Five-loop four-point integrand of $N = 8$ supergravity as a generalized double copy*, *Phys. Rev. D* **96** (2017) 126012 [[arXiv:1708.06807](#)] [[INSPIRE](#)].
- [10] Z. Bern et al., *Ultraviolet Properties of $\mathcal{N} = 8$ Supergravity at Five Loops*, *Phys. Rev. D* **98** (2018) 086021 [[arXiv:1804.09311](#)] [[INSPIRE](#)].
- [11] N.E.J. Bjerrum-Bohr, P.H. Damgaard and P. Vanhove, *Minimal Basis for Gauge Theory Amplitudes*, *Phys. Rev. Lett.* **103** (2009) 161602 [[arXiv:0907.1425](#)] [[INSPIRE](#)].
- [12] S. Stieberger, *Open & Closed vs. Pure Open String Disk Amplitudes*, [arXiv:0907.2211](#) [[INSPIRE](#)].
- [13] S.H. Henry Tye and Y. Zhang, *Dual Identities inside the Gluon and the Graviton Scattering Amplitudes*, *JHEP* **06** (2010) 071 [Erratum *JHEP* **04** (2011) 114] [[arXiv:1003.1732](#)] [[INSPIRE](#)].
- [14] C.R. Mafra, O. Schlotterer and S. Stieberger, *Explicit BCJ Numerators from Pure Spinors*, *JHEP* **07** (2011) 092 [[arXiv:1104.5224](#)] [[INSPIRE](#)].
- [15] C.R. Mafra and O. Schlotterer, *Multiparticle SYM equations of motion and pure spinor BRST blocks*, *JHEP* **07** (2014) 153 [[arXiv:1404.4986](#)] [[INSPIRE](#)].
- [16] C.-H. Fu, P. Vanhove and Y. Wang, *A Vertex Operator Algebra Construction of the Colour-Kinematics Dual numerator*, *JHEP* **09** (2018) 141 [[arXiv:1806.09584](#)] [[INSPIRE](#)].
- [17] C.R. Mafra, O. Schlotterer and S. Stieberger, *Complete N -Point Superstring Disk Amplitude I. Pure Spinor Computation*, *Nucl. Phys. B* **873** (2013) 419 [[arXiv:1106.2645](#)] [[INSPIRE](#)].

- [18] J. Broedel and L.J. Dixon, *Color-kinematics duality and double-copy construction for amplitudes from higher-dimension operators*, *JHEP* **10** (2012) 091 [[arXiv:1208.0876](#)] [[INSPIRE](#)].
- [19] J. Broedel, O. Schlotterer and S. Stieberger, *Polylogarithms, multiple zeta values and superstring amplitudes*, *Fortsch. Phys.* **61** (2013) 812 [[arXiv:1304.7267](#)] [[INSPIRE](#)].
- [20] S. Stieberger and T.R. Taylor, *Closed String Amplitudes as Single-Valued Open String Amplitudes*, *Nucl. Phys. B* **881** (2014) 269 [[arXiv:1401.1218](#)] [[INSPIRE](#)].
- [21] Y.-t. Huang, O. Schlotterer and C. Wen, *Universality in string interactions*, *JHEP* **09** (2016) 155 [[arXiv:1602.01674](#)] [[INSPIRE](#)].
- [22] T. Azevedo, M. Chiodaroli, H. Johansson and O. Schlotterer, *Heterotic and bosonic string amplitudes via field theory*, *JHEP* **10** (2018) 012 [[arXiv:1803.05452](#)] [[INSPIRE](#)].
- [23] N.E.J. Bjerrum-Bohr, *String theory and the mapping of gravity into gauge theory*, *Phys. Lett. B* **560** (2003) 98 [[hep-th/0302131](#)] [[INSPIRE](#)].
- [24] N.E.J. Bjerrum-Bohr, *Generalized string theory mapping relations between gravity and gauge theory*, *Nucl. Phys. B* **673** (2003) 41 [[hep-th/0305062](#)] [[INSPIRE](#)].
- [25] R.R. Metsaev and A.A. Tseytlin, *Curvature Cubed Terms in String Theory Effective Actions*, *Phys. Lett. B* **185** (1987) 52 [[INSPIRE](#)].
- [26] S. He and Y. Zhang, *New Formulas for Amplitudes from Higher-Dimensional Operators*, *JHEP* **02** (2017) 019 [[arXiv:1608.08448](#)] [[INSPIRE](#)].
- [27] S. Lee, C.R. Mafra and O. Schlotterer, *Non-linear gauge transformations in $D = 10$ SYM theory and the BCJ duality*, *JHEP* **03** (2016) 090 [[arXiv:1510.08843](#)] [[INSPIRE](#)].
- [28] C.R. Mafra and O. Schlotterer, *Berends-Giele recursions and the BCJ duality in superspace and components*, *JHEP* **03** (2016) 097 [[arXiv:1510.08846](#)] [[INSPIRE](#)].
- [29] F.A. Berends and W.T. Giele, *Recursive Calculations for Processes with n Gluons*, *Nucl. Phys. B* **306** (1988) 759 [[INSPIRE](#)].
- [30] P. Mastrolia, A. Primo, U. Schubert and W.J. Torres Bobadilla, *Off-shell currents and color-kinematics duality*, *Phys. Lett. B* **753** (2016) 242 [[arXiv:1507.07532](#)] [[INSPIRE](#)].
- [31] J.L. Jurado, G. Rodrigo and W.J. Torres Bobadilla, *From Jacobi off-shell currents to integral relations*, *JHEP* **12** (2017) 122 [[arXiv:1710.11010](#)] [[INSPIRE](#)].
- [32] Z. Bern, L.J. Dixon, D.C. Dunbar and D.A. Kosower, *One loop n point gauge theory amplitudes, unitarity and collinear limits*, *Nucl. Phys. B* **425** (1994) 217 [[hep-ph/9403226](#)] [[INSPIRE](#)].
- [33] Z. Bern, L.J. Dixon, D.C. Dunbar and D.A. Kosower, *Fusing gauge theory tree amplitudes into loop amplitudes*, *Nucl. Phys. B* **435** (1995) 59 [[hep-ph/9409265](#)] [[INSPIRE](#)].
- [34] Z. Bern, L.J. Dixon and D.A. Kosower, *One loop amplitudes for e^+e^- to four partons*, *Nucl. Phys. B* **513** (1998) 3 [[hep-ph/9708239](#)] [[INSPIRE](#)].
- [35] R. Britto, F. Cachazo and B. Feng, *Generalized unitarity and one-loop amplitudes in $N = 4$ super-Yang-Mills*, *Nucl. Phys. B* **725** (2005) 275 [[hep-th/0412103](#)] [[INSPIRE](#)].
- [36] Z. Bern, J.J.M. Carrasco, H. Johansson and D.A. Kosower, *Maximally supersymmetric planar Yang-Mills amplitudes at five loops*, *Phys. Rev. D* **76** (2007) 125020 [[arXiv:0705.1864](#)] [[INSPIRE](#)].
- [37] C.R. Mafra, *Towards Field Theory Amplitudes From the Cohomology of Pure Spinor Superspace*, *JHEP* **11** (2010) 096 [[arXiv:1007.3639](#)] [[INSPIRE](#)].

- [38] C.R. Mafra, O. Schlotterer, S. Stieberger and D. Tsimpis, *A recursive method for SYM n -point tree amplitudes*, *Phys. Rev. D* **83** (2011) 126012 [[arXiv:1012.3981](#)] [[INSPIRE](#)].
- [39] N. Berkovits, *Super Poincaré covariant quantization of the superstring*, *JHEP* **04** (2000) 018 [[hep-th/0001035](#)] [[INSPIRE](#)].
- [40] R.K. Ellis, W.T. Giele, Z. Kunszt and K. Melnikov, *Masses, fermions and generalized D -dimensional unitarity*, *Nucl. Phys. B* **822** (2009) 270 [[arXiv:0806.3467](#)] [[INSPIRE](#)].
- [41] S. Davies, *One-Loop QCD and Higgs to Partons Processes Using Six-Dimensional Helicity and Generalized Unitarity*, *Phys. Rev. D* **84** (2011) 094016 [[arXiv:1108.0398](#)] [[INSPIRE](#)].
- [42] G. Chen and Y.-J. Du, *Amplitude Relations in Non-linear σ -model*, *JHEP* **01** (2014) 061 [[arXiv:1311.1133](#)] [[INSPIRE](#)].
- [43] F. Cachazo, S. He and E.Y. Yuan, *Scattering Equations and Matrices: From Einstein To Yang-Mills, DBI and NLSM*, *JHEP* **07** (2015) 149 [[arXiv:1412.3479](#)] [[INSPIRE](#)].
- [44] C. Cheung and C.-H. Shen, *Symmetry for Flavor-Kinematics Duality from an Action*, *Phys. Rev. Lett.* **118** (2017) 121601 [[arXiv:1612.00868](#)] [[INSPIRE](#)].
- [45] C. Cheung, G.N. Remmen, C.-H. Shen and C. Wen, *Pions as Gluons in Higher Dimensions*, *JHEP* **04** (2018) 129 [[arXiv:1709.04932](#)] [[INSPIRE](#)].
- [46] J.J.M. Carrasco, C.R. Mafra and O. Schlotterer, *Abelian Z-theory: NLSM amplitudes and α' -corrections from the open string*, *JHEP* **06** (2017) 093 [[arXiv:1608.02569](#)] [[INSPIRE](#)].
- [47] S. Mizera and B. Skrzypek, *Perturbative Methods for Effective Field Theories and the Double Copy*, *JHEP* **10** (2018) 018 [[arXiv:1809.02096](#)] [[INSPIRE](#)].
- [48] Z. Bern, T. Dennen, Y.-t. Huang and M. Kiermaier, *Gravity as the Square of Gauge Theory*, *Phys. Rev. D* **82** (2010) 065003 [[arXiv:1004.0693](#)] [[INSPIRE](#)].
- [49] M. Tolotti and S. Weinzierl, *Construction of an effective Yang-Mills Lagrangian with manifest BCJ duality*, *JHEP* **07** (2013) 111 [[arXiv:1306.2975](#)] [[INSPIRE](#)].
- [50] C.-H. Fu and K. Krasnov, *Colour-Kinematics duality and the Drinfeld double of the Lie algebra of diffeomorphisms*, *JHEP* **01** (2017) 075 [[arXiv:1603.02033](#)] [[INSPIRE](#)].
- [51] R. Monteiro and D. O’Connell, *The Kinematic Algebra From the Self-Dual Sector*, *JHEP* **07** (2011) 007 [[arXiv:1105.2565](#)] [[INSPIRE](#)].
- [52] M.H. Goroff and A. Sagnotti, *Quantum Gravity at two loops*, *Phys. Lett. B* **160** (1985) 81 [[INSPIRE](#)].
- [53] M.H. Goroff and A. Sagnotti, *The Ultraviolet Behavior of Einstein Gravity*, *Nucl. Phys. B* **266** (1986) 709 [[INSPIRE](#)].
- [54] Z. Bern, C. Cheung, H.-H. Chi, S. Davies, L.J. Dixon and J. Nohle, *Evanescent Effects Can Alter Ultraviolet Divergences in Quantum Gravity without Physical Consequences*, *Phys. Rev. Lett.* **115** (2015) 211301 [[arXiv:1507.06118](#)] [[INSPIRE](#)].
- [55] Z. Bern, H.-H. Chi, L.J. Dixon and A. Edison, *Two-Loop Renormalization of Quantum Gravity Simplified*, *Phys. Rev. D* **95** (2017) 046013 [[arXiv:1701.02422](#)] [[INSPIRE](#)].
- [56] J.J.M. Carrasco, R. Kallosh, R. Roiban and A.A. Tseytlin, *On the U(1) duality anomaly and the S-matrix of $N = 4$ supergravity*, *JHEP* **07** (2013) 029 [[arXiv:1303.6219](#)] [[INSPIRE](#)].
- [57] Z. Bern, A. Edison, D. Kosower and J. Parra-Martinez, *Curvature-squared multiplets, evanescent effects and the U(1) anomaly in $N = 4$ supergravity*, *Phys. Rev. D* **96** (2017) 066004 [[arXiv:1706.01486](#)] [[INSPIRE](#)].

- [58] Z. Bern, J. Parra-Martinez and R. Roiban, *Canceling the U(1) Anomaly in the S-Matrix of $N = 4$ Supergravity*, *Phys. Rev. Lett.* **121** (2018) 101604 [[arXiv:1712.03928](#)] [[INSPIRE](#)].
- [59] C.R. Mafra and O. Schlotterer, *Towards one-loop SYM amplitudes from the pure spinor BRST cohomology*, *Fortsch. Phys.* **63** (2015) 105 [[arXiv:1410.0668](#)] [[INSPIRE](#)].
- [60] C.R. Mafra and O. Schlotterer, *Two-loop five-point amplitudes of super Yang-Mills and supergravity in pure spinor superspace*, *JHEP* **10** (2015) 124 [[arXiv:1505.02746](#)] [[INSPIRE](#)].
- [61] M. Berg, I. Buchberger and O. Schlotterer, *String-motivated one-loop amplitudes in gauge theories with half-maximal supersymmetry*, *JHEP* **07** (2017) 138 [[arXiv:1611.03459](#)] [[INSPIRE](#)].
- [62] S. He, O. Schlotterer and Y. Zhang, *New BCJ representations for one-loop amplitudes in gauge theories and gravity*, *Nucl. Phys. B* **930** (2018) 328 [[arXiv:1706.00640](#)] [[INSPIRE](#)].
- [63] C.R. Mafra, *Berends-Giele recursion for double-color-ordered amplitudes*, *JHEP* **07** (2016) 080 [[arXiv:1603.09731](#)] [[INSPIRE](#)].
- [64] C.R. Mafra and O. Schlotterer, *Non-abelian Z-theory: Berends-Giele recursion for the α' -expansion of disk integrals*, *JHEP* **01** (2017) 031 [[arXiv:1609.07078](#)] [[INSPIRE](#)].
- [65] F.A. Berends and W.T. Giele, *Multiple Soft Gluon Radiation in Parton Processes*, *Nucl. Phys. B* **313** (1989) 595 [[INSPIRE](#)].
- [66] R. Kleiss and H. Kuijf, *Multigluon cross sections and 5-jet production at hadron colliders*, *Nucl. Phys. B* **312** (1989) 616 [[INSPIRE](#)].
- [67] V. Del Duca, L.J. Dixon and F. Maltoni, *New color decompositions for gauge amplitudes at tree and loop level*, *Nucl. Phys. B* **571** (2000) 51 [[hep-ph/9910563](#)] [[INSPIRE](#)].
- [68] A.A. Rosly and K.G. Selivanov, *On amplitudes in selfdual sector of Yang-Mills theory*, *Phys. Lett. B* **399** (1997) 135 [[hep-th/9611101](#)] [[INSPIRE](#)].
- [69] A.A. Rosly and K.G. Selivanov, *Gravitational SD perturbation*, [hep-th/9710196](#) [[INSPIRE](#)].
- [70] K.G. Selivanov, *SD perturbation in Yang-Mills + gravity*, *Phys. Lett. B* **420** (1998) 274 [[hep-th/9710197](#)] [[INSPIRE](#)].
- [71] K.G. Selivanov, *Post-classicism in Tree Amplitudes*, in proceedings of the *34th Rencontres de Moriond on Electroweak Interactions and Unified Theories*, Les Arcs, France, 13–20 March 1999, pp. 473–478 [[hep-th/9905128](#)] [[INSPIRE](#)].
- [72] W.A. Bardeen, *Selfdual Yang-Mills theory, integrability and multiparton amplitudes*, *Prog. Theor. Phys. Suppl.* **123** (1996) 1 [[INSPIRE](#)].
- [73] K.G. Selivanov, *On tree form-factors in (supersymmetric) Yang-Mills theory*, *Commun. Math. Phys.* **208** (2000) 671 [[hep-th/9809046](#)] [[INSPIRE](#)].
- [74] R. Ree, *Lie elements and an algebra associated with shuffles*, *Ann. Math.* **62** (1958) 210.
- [75] C. Duhr, S. Hoeche and F. Maltoni, *Color-dressed recursive relations for multi-parton amplitudes*, *JHEP* **08** (2006) 062 [[hep-ph/0607057](#)] [[INSPIRE](#)].
- [76] F.A. Berends, W.T. Giele and H. Kuijf, *Exact and approximate expressions for multigluon scattering*, *Nucl. Phys. B* **333** (1990) 120 [[INSPIRE](#)].
- [77] F. Cachazo, S. He and E.Y. Yuan, *Scattering of Massless Particles: Scalars, Gluons and Gravitons*, *JHEP* **07** (2014) 033 [[arXiv:1309.0885](#)] [[INSPIRE](#)].
- [78] Z. Bern, L.J. Dixon, M. Perelstein and J.S. Rozowsky, *Multileg one loop gravity amplitudes from gauge theory*, *Nucl. Phys. B* **546** (1999) 423 [[hep-th/9811140](#)] [[INSPIRE](#)].

- [79] N.E.J. Bjerrum-Bohr, P.H. Damgaard, T. Sondergaard and P. Vanhove, *The Momentum Kernel of Gauge and Gravity Theories*, *JHEP* **01** (2011) 001 [[arXiv:1010.3933](#)] [[INSPIRE](#)].
- [80] J. Polchinski, *String theory. Volume 1: An introduction to the bosonic string*, Cambridge Monographs on Mathematical Physics, [Cambridge University Press](#), Cambridge U.K. (2007).
- [81] M.B. Green and J.H. Schwarz, *Supersymmetrical Dual String Theory. 2. Vertices and Trees*, *Nucl. Phys. B* **198** (1982) 252 [[INSPIRE](#)].
- [82] J.H. Schwarz, *Superstring Theory*, *Phys. Rept.* **89** (1982) 223 [[INSPIRE](#)].
- [83] A.A. Tseytlin, *Vector Field Effective Action in the Open Superstring Theory*, *Nucl. Phys. B* **276** (1986) 391 [*Erratum ibid.* **B 291** (1987) 876] [[INSPIRE](#)].
- [84] L.A. Barreiro and R. Medina, *Revisiting the S-matrix approach to the open superstring low energy effective lagrangian*, *JHEP* **10** (2012) 108 [[arXiv:1208.6066](#)] [[INSPIRE](#)].
- [85] L.A. Barreiro and R. Medina, *RNS derivation of N-point disk amplitudes from the revisited S-matrix approach*, *Nucl. Phys. B* **886** (2014) 870 [[arXiv:1310.5942](#)] [[INSPIRE](#)].
- [86] R.H. Boels and R. Medina, *Graviton and gluon scattering from first principles*, *Phys. Rev. Lett.* **118** (2017) 061602 [[arXiv:1607.08246](#)] [[INSPIRE](#)].
- [87] Y. Zhang, *CHY formulae in 4d*, *JHEP* **07** (2017) 069 [[arXiv:1610.05205](#)] [[INSPIRE](#)].
- [88] L.J. Dixon and Y. Shadmi, *Testing gluon selfinteractions in three jet events at hadron colliders*, *Nucl. Phys. B* **423** (1994) 3 [*Erratum ibid.* **B 452** (1995) 724] [[hep-ph/9312363](#)] [[INSPIRE](#)].
- [89] L.J. Dixon, E.W.N. Glover and V.V. Khoze, *MHV rules for Higgs plus multi-gluon amplitudes*, *JHEP* **12** (2004) 015 [[hep-th/0411092](#)] [[INSPIRE](#)].
- [90] T. Cohen, H. Elvang and M. Kiermaier, *On-shell constructibility of tree amplitudes in general field theories*, *JHEP* **04** (2011) 053 [[arXiv:1010.0257](#)] [[INSPIRE](#)].
- [91] C.R. Mafra and O. Schlotterer, *Solution to the nonlinear field equations of ten dimensional supersymmetric Yang-Mills theory*, *Phys. Rev. D* **92** (2015) 066001 [[arXiv:1501.05562](#)] [[INSPIRE](#)].
- [92] Y.-X. Chen, Y.-J. Du and B. Feng, *A Proof of the Explicit Minimal-basis Expansion of Tree Amplitudes in Gauge Field Theory*, *JHEP* **02** (2011) 112 [[arXiv:1101.0009](#)] [[INSPIRE](#)].
- [93] D.J. Gross and J.H. Sloan, *The Quartic Effective Action for the Heterotic String*, *Nucl. Phys. B* **291** (1987) 41 [[INSPIRE](#)].
- [94] M.T. Grisaru, *Two Loop Renormalizability of Supergravity*, *Phys. Lett. B* **66** (1977) 75 [[INSPIRE](#)].
- [95] A. Gregori, E. Kiritsis, C. Kounnas, N.A. Obers, P.M. Petropoulos and B. Pioline, *R^2 corrections and nonperturbative dualities of $N = 4$ string ground states*, *Nucl. Phys. B* **510** (1998) 423 [[hep-th/9708062](#)] [[INSPIRE](#)].
- [96] M. Berg, I. Buchberger and O. Schlotterer, *From maximal to minimal supersymmetry in string loop amplitudes*, *JHEP* **04** (2017) 163 [[arXiv:1603.05262](#)] [[INSPIRE](#)].
- [97] H. Johansson and J. Nohle, *Conformal Gravity from Gauge Theory*, [arXiv:1707.02965](#) [[INSPIRE](#)].