

KINETIC CONCEPT OF THE STRENGTH OF SOLIDS*

S. N. Zhurkov**

ABSTRACT

An examination of the time to failure for uniaxial tensile specimens of some 50 materials, measured in some cases over ten decades of time, has suggested a universal rate relation between lifetime, stress, and temperature of the form $\tau = \tau_0 \exp [(U_0 - \gamma\sigma)/kT]$. The constant τ_0 is essentially the reciprocal of the natural oscillation frequency of atoms in the solid, U_0 is the binding energy on the atomic scale, and γ is proportional to the disorientation of the molecular structure. Assuming the kinetic nature of bond destruction through the thermofluctuation mechanism, direct experimental verification of the phenomenon for polymers has been obtained using electron paramagnetic resonance.

THERMOFLUCTUATION MECHANISM OF FRACTURE

In this report we shall consider the problem of the strength of solids on the basis of the kinetic concept of the mechanism of fracture. Within this concept, the fracture of a solid is considered as a time process whose rate is determined by mechanical stress and temperature. From this standpoint the investigation of the time and temperature factors becomes very important for the understanding of the mechanism of the phenomenon. In this connection, systematic studies of the relationship between the lifetime of solids under load and the magnitude of the tensile stress and temperature have been carried out.***

The lifetime of solids has been studied in uniaxial tension on small specimens which had the shape of strips, or a bundle of fibers. (Fig. 1). During the tests, the tensile stress in a specimen was maintained constant by means of a specially shaped lever with a variable arm. This device allowed us to carry out lifetime studies at constant stress, even for very long test durations.

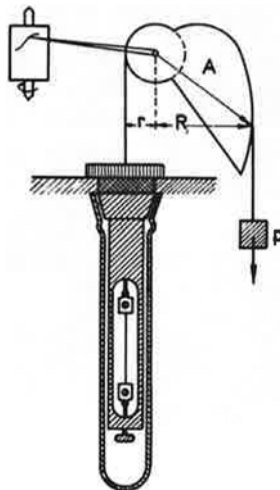

Fig. 1. Diagram of apparatus for long-duration studies of the lifetime of solids.

* Invited lecture presented at the International Conference on Fracture, Sendai, Japan, Sept. 1965.

** Ioffe Physical Technical Institute, USSR Academy of Sciences, Leningrad, USSR.

*** The experimental data discussed in this report have been obtained at the Ioffe Physical Technical Institute, Leningrad.

In short-time tests for lifetime, a damper, which was used for stress stabilization, was connected in series with the specimen being tested. Impact loading was imposed by means of an electromagnetic impact machine and was measured with a low-inertia transducer. The experimental arrangement is shown in Figure 2.

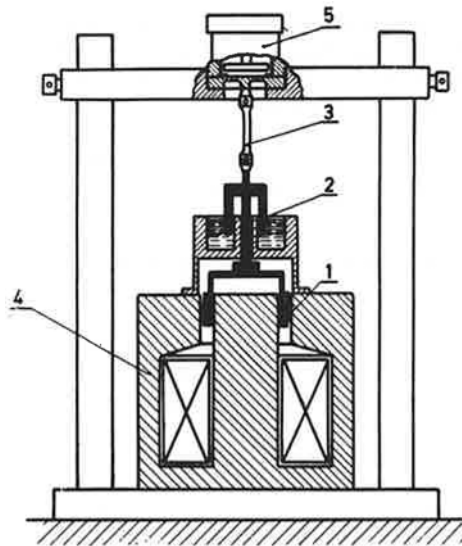

Fig. 2. Diagram of electromagnetic apparatus with a liquid damper for impact studies (Ref. 1.)

For example, oscillographic recording of stress oscillations in a specimen subjected to an impact test is shown in Figure 3. Curve 1 illustrates the

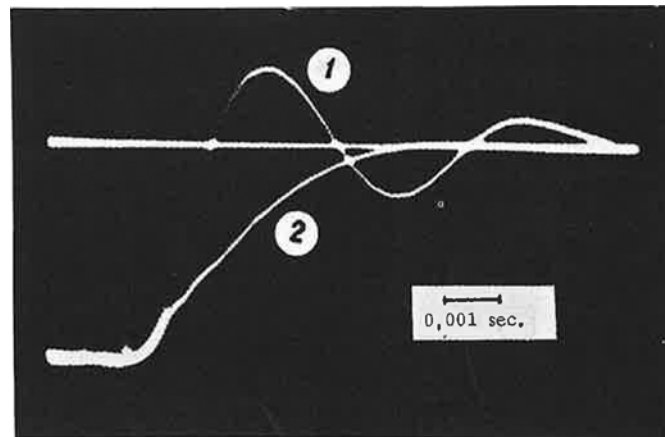

Fig. 3. Oscillogram of stress oscillations in a specimen in an impact test.
1. Without damper
2. With liquid damper.

stress without the damper, and curve 2 with the damper.

It is seen that by properly choosing a damper, one succeeds in damping oscillations and stabilizing the stress after a short time of about 0.001 sec. For illustration, Figure 4 shows an oscillogram of the fracture of an aluminium specimen at a stress of 6 kg/mm^2 .

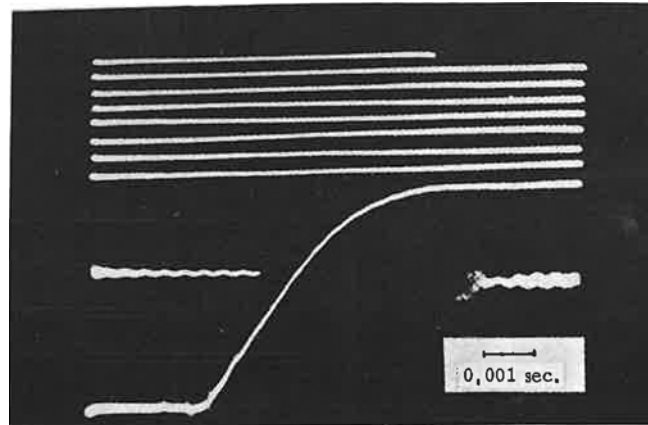

Fig. 4. Oscillographic recording of time to break for polycrystalline aluminum at stress of 6 kg/mm^2 .

Use of this equipment permitted us to study the lifetime of solids at different temperatures within a very broad time-to-break range covering almost 10 decades of time.

Experiments have been carried out on different materials -- metals, alloys, non-metallic crystals, and polymers. 50 Materials have been studied. The experimental data obtained permitted us to establish a fundamental relation common for all solids. This relation is presented in Figure 5.

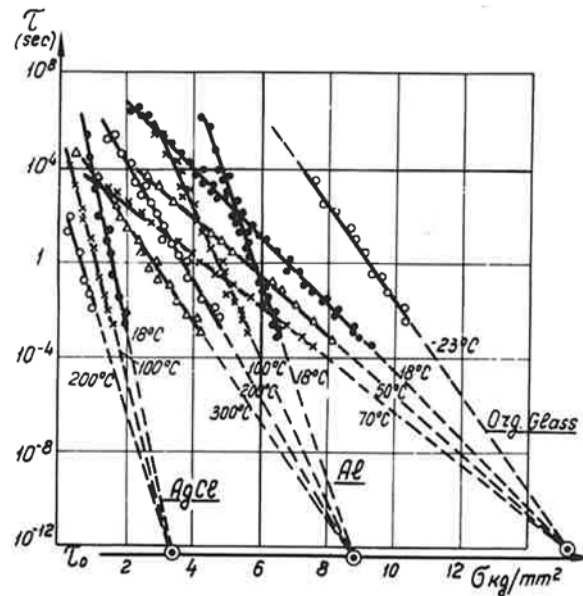

Fig. 5. Time and temperature dependence of the lifetime of solids on stress.

1. Silver chloride (Reference 4)
2. Aluminum (Reference 5)
3. Plexiglas (Reference 6)

The materials taken for illustration are polycrystalline aluminum, silver chloride, and plexiglas.

As seen from Figure 5, the time and temperature dependence of the strength of solids, of both crystalline and amorphous structure with dif-

ferent types of interatomic binding, are identical. At a fixed temperature, the lifetime of a specimen under load increases exponentially with the decrease of tensile stress. The experimental values of the lifetime vs. tensile stress, when plotted in the semi-log coordinates $\ln \tau, \sigma$, fit well to straight lines whose slopes are determined by temperature. These lines form a "fan" converging to a pole when extrapolated. This relationship has been found correct as a general rule and valid for describing the strength properties of all solids in this investigation.

It is easy to demonstrate that the relationship revealed between the lifetime τ , the tensile stress σ , and absolute temperature T can be written in the form of a kinetic operation

$$\tau = \tau_0 \cdot \exp [(U_0 - \gamma\sigma)/kT] \quad (1)$$

where k is the Boltzmann's constant, τ_0 , U_0 and γ being constant coefficients which, as shown below, represent material constants of solids.

For the case of a constant temperature, Eq. (1) may be transformed to a simpler relation for the lifetime:

$$\tau = A \cdot \exp(-\alpha\sigma) \quad (1a)$$

where $A = \tau_0 \cdot \exp(U_0/kT)$, and $\alpha = \gamma/kT$.

To understand the physical sense of the kinetic equation, it appeared very important to establish the meaning of the coefficients τ_0 , U_0 and γ .

We will consider first the factor τ_0 before the exponent. Its magnitude can be determined from the position of the pole where the straight lines shown in Figure 5 converge. For silver chloride, aluminum, and plexiglas, the order of magnitude of this parameter was found to be 10^{-13} sec. Experimental data for other solids indicate the coefficient τ_0 to be of the same order of magnitude, independent of the structure and chemical nature of the solid in question. It is essential that by both its magnitude and dimensionality, the parameter τ_0 coincides with the reciprocal of the natural oscillation frequency of atoms in solids.

The second parameter U_0 in the kinetic formula (1) can be interpreted as the magnitude of the energy barrier determining the probability of breakage of the bonds responsible for strength. Under load, this barrier, as seen from Eq. (1), decreases linearly with the tensile stress σ . Such dependence of the effective barrier results in a sharp acceleration of the fracture process in a mechanically stressed body, and in a decrease of its lifetime under load.

To calculate the constant U_0 , we will rewrite Eq. (1) as follows:

$$kT \ln(\tau/\tau_0) = U_0 - \gamma\sigma. \quad (2)$$

The left-hand side of this equation is equal to the magnitude of the effective barrier $U = kT \ln(\tau/\tau_0)$. Since the parameter τ_0 has been shown to be constant for different solids, we may take its value as 10^{-13} sec. Now we can calculate from the experimental data the magnitude of the effective barrier for various stresses and temperature.

Such treatment is interesting in that it permits us to check the correctness of formula (1) and at the same time to determine the magnitude of the initial barrier U_0 and the coefficient γ . If the kinetic equation is correct and agrees with experimental data, one should expect a linear relationship between U and σ . The results of the checking for a number of metals and polymers are shown in Figure 6 and 7. It is seen that the expected linear dependence of the effective barrier on tensile stress is observed to be sufficiently accurate, both in metals and in polymer materials.

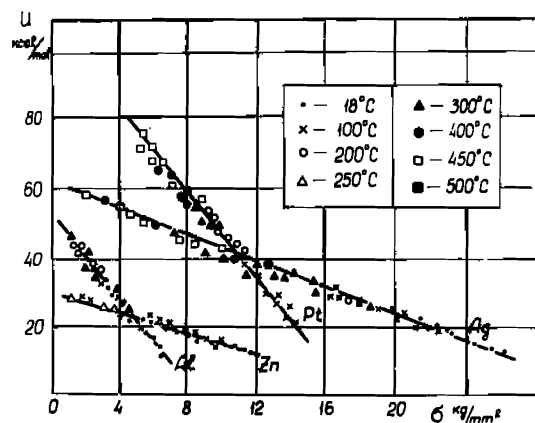

Fig. 6. Effective barrier U kcal/mol vs. tensile stress σ kg/mm² for polycrystalline metals.

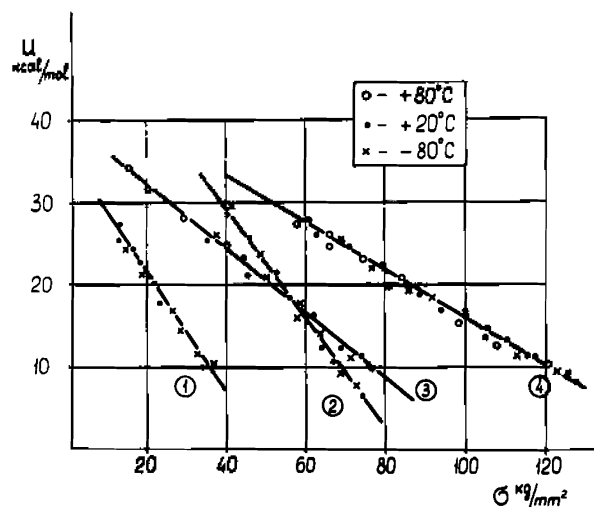

Fig. 7. Decrease of energy barrier U kcal/mol with tensile σ kg/mm² for polymers (fibres).

1. Polyvinyl chloride.
2. Polypropylene.
3. Viscose yarn.
4. Capron (Nylon 6).

The linear relationship permits, by extrapolating the straight lines to their intersection with the y-axis, the evaluation of the magnitude of the initial energy barrier U_0 . The values of U_0 obtained in this way for a number of polycrystalline metals with face-centered, hexagonal and body-centered lattice are given in Table 1. The data presented in the Table indicate that the values of U_0 lie close to the binding energy of atoms in metals. For comparison, the second column contains heats of sublimation of metals taken from the monograph of Prof. F. Seith, The Modern Theory of Solids. It is seen that for metals with different **crystal lattices, the constant U_0 fits well to the energy of sublimation.** In other words, it is equal to the **binding energy of atoms in the crystal lattice of metals.**

Experiments indicate that in polymers a similar correlation exists between the energy constant U_0 and the energy of breakage of chemical bonds in chain macromolecules. Table 2 contains the values of U_0 from mechanical tests and of the bond rupture energy E in thermal destruction of polymers for a number of polymers tested for their lifetimes as plates or fibers.

TABLE 1

Binding Energies of Atoms in Metals from Mechanical Test Data (U_0) and from Sublimation Heat Measurements (E)

Metals	U_0	Heat of Sublimation. E	Metals	U_0	Heat of Sublimation. E
	Kcal/mole	Kcal/mole		Kcal/mole	Kcal/mole
Pt -polycryst.	120	127	Pb -Polycryst.	42	47.5
Ni -polycryst.	87	85	Mg-polycryst.	34	36.3
Cu-polycryst.	82	81.2	Zn-polycryst.	30	
Ag-polycryst.	62	68	Zn-single cryst.*	35	31.5
Al-polycryst.	53		Cd-polycryst.*	28	26.8
Al-single cryst.	54	55			

* Taken from: V.I. Likhtman, L.S. Brykhanov and I.A. Andreyev, Dokl. Akad. Nauk SSSR, 139, 359 (1960).

TABLE 2

Interatomic Binding Energy in Chain Molecules of Polymers U_0 - from Mechanical Testing Data and Values of E - from Thermal Destruction

Polymer	U_0	E
	Kcal/mole	Kcal/mole
Polyvinyl chloride	35	32
Polystyrene	54	55
Polymethyl methacrylate	54	52-53
Polypropylene	56	58-55
Teflon	75	80-76
Capron (Nylon 6)	45	43

This coincidence of the atomic binding energy with the constant U_0 is not accidental. We are of the opinion that it indicates the existence of a direct connection between the kinetics of fracture of solids under the action of mechanical stress and the rupture of interatomic bonds, and permits us to consider the mechanism of fracture of solids as a kinetic process described by Eq. (1).

Of particular importance in this connection is the coincidence of the parameters τ_0 and U_0 with fundamental constants of solids, namely, frequency of thermal oscillations of atoms and interatomic binding energy. In this sense the fracture of solids is determined by thermal motion which plays the major role. In a stressed body, chemical bonds are broken by thermal fluctuations, the possibility of this process depending strongly on the magnitude of tensile stress. The tensile stress excites the bond being ruptured and reduces the activation barrier. The magnitude of this decrease of the activation barrier will be determined by the product $\gamma\sigma$. Therefore, the decrease of the barrier will depend on the parameter γ .

The coefficient γ represents an important parameter determining the strength of solids. Indeed, it follows from Eq. (1) that $\sigma_{fr} = [U_0 - kT \ln(\tau/\tau_0)]/\gamma$. At constant temperature and testing rate, the expression in the brackets

will be constant and hence $\sigma_{fr} = A/\gamma$. This means that the tensile strength of solids will vary in inverse proportion to the parameter γ . Therefore, in order to identify the coefficient γ , we have studied the dislocation structure of metals using the low-angle x-ray scattering technique. A direct correlation between the parameter γ and the disorientation of the structure has been found. It turned out that the more disoriented the structure in a metal, that is, the higher the dislocation density at the slip planes, the smaller the coefficient γ , and hence the higher the metal strength.

On the other hand, in polymers, it was found that the strongest influence on the parameter γ is the molecular orientation of the polymer chains. A study of orientation in polymer fibres by the method of infrared dichroism reveals a direct connection between the coefficient γ and the orientation factor. However, the high sensitivity of the parameter γ to various structural changes in solids makes precise formulation of the physical meaning of this coefficient difficult. One interpretation which agrees well with the experimental data and is in accord with the kinetic concept of mechanical fracture, is based on the supposition of a nonuniform distribution of stress over the bonds being broken. From this basis, one may interpret the parameter γ as a coefficient taking into account the overstress on a bond as compared to the average stress in a specimen.

The kinetic concept of strength discussed permits a conventional separation of the fracture process into three stages:

- 1) Excitation of the bonds being broken by tension stresses;
- 2) Breakage of excited bonds by thermal fluctuations;
- 3) Accumulation of rupture bonds resulting in the loss of the stability in the body with its eventual breakdown.

The first two stages of the process have already been briefly considered when discussing the physical meaning of the two parameters τ_0 and U_0 . We think that a consideration of the third stage of fracture would be very important to gain understanding of the transition from the microprocess of the rupture of chemical bonds to the macroprocess of the fracture of the specimen in parts.

It is a well known fact that in its early stage the fracture is localized in microcracks, whose growth divides the body into parts. Such localization can be explained on the basis of the kinetic concept if one assumes that the rate of fracture at the crack tip is higher because of a higher local stress. It therefore appeared to be of interest to investigate the kinetics of crack growth.

According to Griffith theory, a crack grows stepwise, but does not change in size until the stress has reached a critical value. As soon as the critical threshold has been attained, the crack begins to grow catastrophically at a rate which closely approaches the velocity of sound. A number of papers have reported both a rapid and a slow growth of cracks at stresses below the critical value. Our experiments conducted on through cracks in thin foils of polymers have shown that the rate of crack growth increases with stress monotonically.

Measurements were carried out on individual cracks generated spontaneously under load at the edge of a strip subjected to tension. Such individual cracks then began to grow in length perpendicular to the axis of strip tension. Using a microcinematographic technique, we investigated its rate changing by 4 to 5 orders of magnitude. The experiments have shown that the rate of crack length growth increases exponentially with the stress. Besides, it has been found that at a given stress the time required for a crack to initiate is much less than the time of its growth to the fracture of a specimen. Knowing the dependence of growth rate on stress, and using the kinetic Equation (1a), this permits the calculation of the lifetime τ . The calculated values have been found to agree well with those obtained by direct measurements. (Table 3).

TABLE 3
Comparison of Calculated and Experimental Values of
Time-to-break for Thin Polymer Strips (9)

Cellulose diacetate		Cellulose triacetate	
Experimental (sec)	Calculated (sec)	Experimental (sec)	Calculated (sec)
5.7×10^5	5.7×10^5	9.5×10^4	8.4×10^4
1.4×10^5	1.3×10^5	1.3×10^4	1.1×10^4
6.4×10^4	7.4×10^4	7.4×10^3	7.0×10^3
2.8×10^4	2.5×10^4	2.8×10^3	3.4×10^3
1.6×10^4	1.7×10^4	1.6×10^3	1.9×10^3
1.6×10^3	1.7×10^3	3.6×10^2	3.1×10^2
4.0×10^2	3.2×10^2	2.8×10^2	2.9×10^2

This result indicates that the localization of fracture in a crack does not substantially change kinetics of the fracture process, which also turns out to obey the principal equation (1) in this case. Hence it permits the evaluation of the limiting rate of crack growth, which will be determined by the condition that the bond fluctuation breakage possibility is unity. In this case, during one oscillation the tip of the crack will displace by an interatomic distance. Therefore, the maximum crack growth rate is $V \approx 10^{-8}/10^{-13} = 10^5$ cm/sec or 1 km/sec. This value is close to the velocity of sound in solids, and it is in good agreement with direct measurements of the crack growth rate carried out by a number of investigators.

The condition of reaching the limiting rate is set by the equality $\exp[-(U_0 - \gamma\sigma)/kT] = 1$ or $(U_0 - \gamma\sigma)/kT = 0$. It is seen from this condition that at a conventional testing temperature the maximum rate of fracture propagation is reached at $U_0 - \gamma\sigma = 0$. The rate of crack propagation under this condition will be characterized as a barrierless process which does not depend on temperature.

One deviation from Eq. (1), which is observed experimentally, should be noted. It concerns a variation of lifetime at very small stresses and a high temperature. Here a systematic deviation is revealed from the exponential law. For different solids, as shown in Figure 8, the log lifetime begins to grow faster with diminishing tensile stress than is specified by formula (1a). At a stress approaching zero, the lifetime becomes infinitely large. The reason for such deviation, which is common for different solids, has not yet been elucidated. One of the reasons consists undoubtedly in the reversibility of the process, that is, in the recombination of the ruptured bonds. One may expect that the reverse process will play an even greater role with the decrease of tensile stress. At a zero stress, the recombination of ruptured bonds will become equal to the rate of their rupture. The total bond rupture effect becomes zero, and lifetime under load becomes infinite.

Besides this principal deviation, one more violation of the general relationship is frequently observed. It consists of a deviation of the relationship $\ln \tau = f(\sigma)$ from the straight line expected from Eq. (1a). This deviation is not basic and is associated with instability of materials during test. Stabilization of the structure results, as a rule, in the straightening out of the curve to its total coincidence with the general kinetic equation (1). One should bear in mind the specified deviations when studying the time

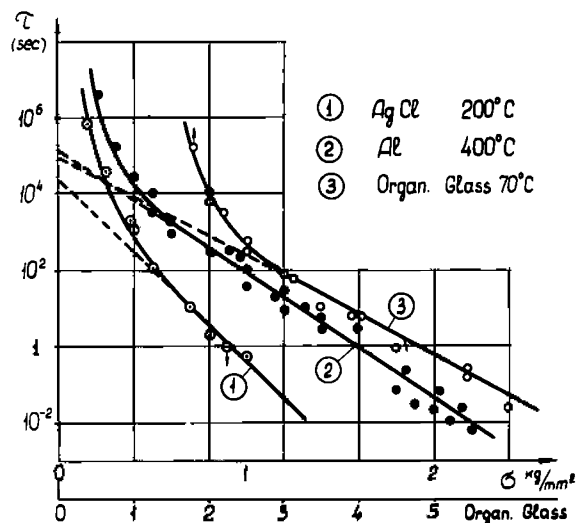

Fig. 8. Variation of the lifetime of solids at small stresses and high temperatures.

and temperature dependence of the strength of solids because they may lead to wrong conclusions and erroneous interpretation.

POLYMER FRACTURE KINETICS BY EPR

As noted previously the observed variation of the lifetime of solids under load permits us to make a suggestion on the kinetic nature of the destruction of solids based on thermal fluctuation rupture of the bonds responsible for the strength of solids. Several theoretical works have been devoted to the development of the kinetic concept of the strength of polymers. However, direct experimental data are required to confirm the kinetic concept of the fracture of solids.

A good method for this purpose involves the electron paramagnetic resonance (EPR) of radicals formed during rupture of the polymer chains. If the strength of polymers is really determined by the kinetics of generation and accumulation of free radicals in mechanical fracture, one might expect the method of electron paramagnetic resonance to yield direct information on the mechanism of fracture. The possibility of applying the EPR method to the study of polymer strength has been demonstrated for the first time in a series of our experiments.

In these experiments, polymers were subjected to mechanical fracture by crushing, milling, and tensile deformation. Experiments were carried out both in air and in vacuum, at room and liquid nitrogen temperatures. The results presented here pertain to our latest studies on fibres of capron (nylon 6) fractured by a tensile stress. A bundle of thin fibres was fractured at room temperature in the cavity resonator of a 3 cm-range spectrometer. The fibres were arranged along the axis of the cylindrical resonator and subjected to uniaxial tension, i. e. along the axis of the cylinder. The experiments have shown that under the action of the tensile stress on fibres, paramagnetic centers resulting from the rupture of chemical bonds in chain molecules are really formed. The concentration of such free radicals has been found to grow smoothly at a constant stress and to increase rapidly with the increase of the tensile stress.

Figure 9 shows the spectra of free radicals detected in stressed capron fibres. It is seen that before loading there are no free radicals in the

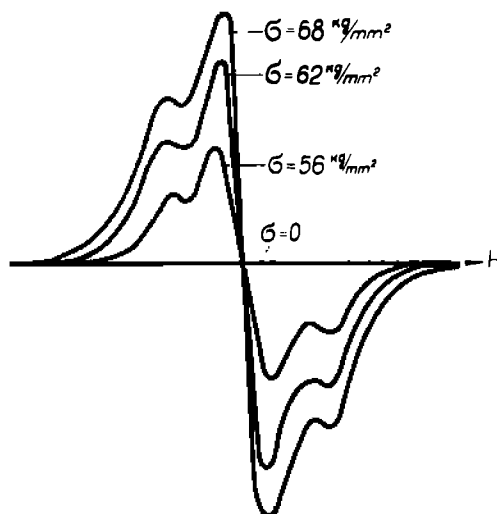

Fig. 9. EPR-spectrum of mechanically stressed capron fibres.

polymer. On application of load, a spectrum of free radicals of a complicated structure appears. The shape of the spectrum does not change significantly with stress; however, the magnitude of the signal increases sharply with the increase of the stress. This indicates an increase in the concentration of ruptured bonds in the polymer and permits us to follow the kinetics of formation of the microfractures in a material under stress. These data are very important from the standpoint of the kinetic concept of strength. If the lifetime of a solid polymer under stress is really determined by the rate of bond rupture, then one may expect an exponential increase in the radical formation rate $V = dc/dt$ with tensile stress σ , since lifetime is an exponential function of stress ($\tau = A \cdot \exp[-\alpha\sigma]$). Direct measurements of EPR spectra have shown that the rate of formation of free radicals does grow exponentially with the increase of stress. The result for capron at room temperature is shown in Figure 10.

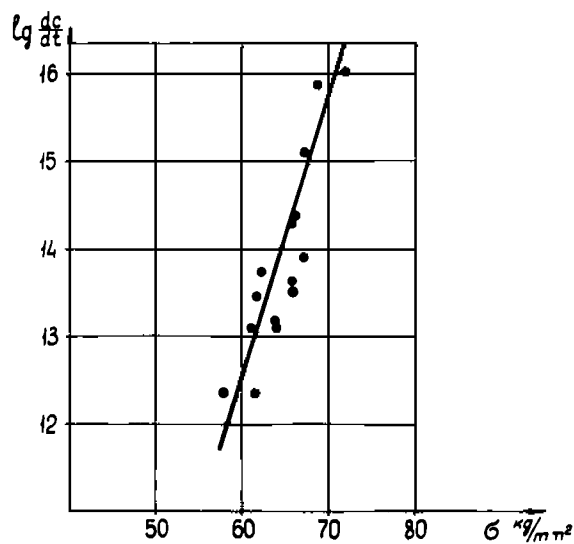

Fig. 10. Rate of formation of free radicals dc/dt vs. tensile stress.

As a final confirmation of the conclusion that the fracture of polymers is unambiguously determined by the kinetics of rupture of chemical bonds, revealed by the EPR method, we have carried out quantitative measurements of the lifetime under stress and of the rate of accumulation of free radicals. For this purpose, capron fibres were fractured in the cavity resonator of the EPR spectrometer while the rate of formation of free radicals was determined and the specimen lifetime was measured. The rate of bond rupture, as has already been shown, grows by an exponential law with increase of tensile stress. On the other hand, the lifetime under stress varies by the same law. By comparing these two relationships, one can answer the question whether the kinetics of bond rupture represents the basis of the strength of polymers, or whether it only accompanies fracture and plays a minor role.

These relationships may be written in the following way:

$$\tau = A \cdot \exp[-\alpha\sigma] \quad \text{for lifetime under tensile stress,}$$

$$\nu = B \cdot \exp[\beta\sigma] \quad \text{for bond rupture rate.}$$

If the lifetime of a stressed polymer is completely determined by the rate of accumulation of the ruptured bonds, then one might expect the rate constants α and β to be equal. In this case the lifetime and the rupture rate, at equal stress and temperature, should be related by the equality:

$$\tau\nu = \text{const.} \quad (3)$$

An experimental verification of this relation on capron fibres tested for fracture at room temperature, at $+50^\circ\text{C}$, and at -50°C , has shown a good agreement with the theoretical prediction. (Figure 11). It is seen that the

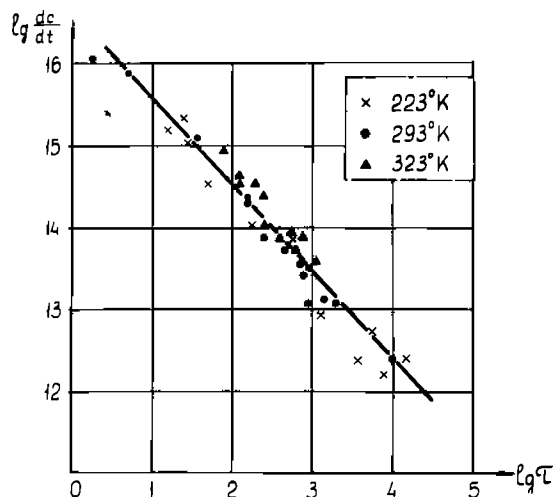

Fig. 11. Relation between the lifetime of capron fibres and rate of formation of free radicals at different stresses and temperatures.

log lifetime really decreases proportionally to the rate of chemical bond rupture, the coefficient of proportionality being 1.

Thus the EPR method proved to be a very effective tool by permitting a direct confirmation of the kinetic nature of polymer fracture. The atomic kinetic interpretation of the principal equation (1) has found direct confirmation in these experiments.

Unfortunately, it would be much more difficult to obtain a similarly direct proof of the rupture of interatomic bonds during the mechanical fracture of metals, because the absence of paramagnetic properties in ruptured metallic bonds does not allow the application of the EPR method. However,

we think that the identity of a general law covering the lifetime of both polymers and metals, as well as the coincidence of the activation energy for the rate of fracture with the interatomic binding energy, permits generalization of the kinetic concept of strength to all solids.

Received September 18, 1965.

REFERENCES

1. S.N.Zhurkov and E.E.Tomashevsky, "Investigation of the strength of solids", Zhurn.Tekhn.Fiz., XXV, 66 (1955).
2. S.N.Zhurkov and B.I.Narzulayev, "The time dependence of the strength of solids", Zhurn.Tekhn.Fiz., XXIII, 1677 (1953).
3. S.N.Zhurkov, "Das Problem der Festigkeit fester Körper", Z.für Phys.Chemie, 213, 183 (1960).
4. S.N.Zhurkov, B.Ya.Levin and T.P.Sanfirova, "The temperature and time dependence of the strength of silver chloride", Fiz.Tv.Tela, 2, 1033 (1960).
5. S.N.Zhurkov and T.P.Sanfirova, "The temperature and time dependence of the strength of pure metals", Dokl.Akad.Nauk SSSR, 101, 237 (1955).
6. S.N.Zhurkov, "The problem of the strength of solids", Vestnik Akad.Nauk SSSR, 11, 78 (1957).
7. S.N.Zhurkov and S.A.Abasov, "The relation between mechanical strength and thermal destruction of polymers", Vysokomol. soyedineniya, 4, 1703 (1962).
8. S.N.Zhurkov, V.I.Detekhtin and A.I.Slutsker, "The disorientation of blocks and the strength of metals", Fiz.Tv.Tela, 5, (1963).
9. S.N.Zhurkov and E.E.Tomashevsky, "A microscopic study of crack growth in fracture", Zhurn.Tekhn.Fiz., XXVII, 1248 (1957).
10. A.Tobolsky and H.Eyring, "Mechanical properties of polymeric materials", J.Chem.Phys., 11, 125 (1943).
11. F.Bueche, "Tensile strength of plastics below the glass temperature", J. Appl.Phys., 28, 784 (1957).
12. A.I.Gubarov and A.D.Chevychelov, "On the theory of tensile strength of solids", Fiz.Tv.Tela, 4, 928 (1962).
13. S.E.Bresler, S.N.Zhurkov, E.N.Kozbekov, E.M.Sominsky and E.E.Tomashevsky, "Investigation of macroradicals forming in mechanical destruction of polymers", Zhurn.Tekhn.Fiz., XXIX, 358 (1959).
14. S.N.Zhurkov, E.E.Tomashevsky and V.A.Zakrevsky, "Investigation of macroradicals forming in mechanical destruction of polymers", Fiz.Tv.Tela, 3, 2841 (1961).
15. S.N.Zhurkov, A.Ya.Savostin and E.E.Tomashevsky, "Investigation of the mechanism of fracture in polymers by the EPR-method", Dokl.Akad.Nauk USSR, 159, 303 (1964).

RÉSUMÉ - Un examen du temps de rupture pour des échantillons de traction uniaxes d'environ 50 matériaux, mesuré dans certains cas sur 10 décades de temps, a suggéré une relation universelle entre la durée de la résistance, la traction et la température, de la forme:

$$\tau = \tau_0 \exp [(U_0 - \gamma\sigma)/kT]$$

La constante τ_0 est essentiellement la réciproque de la fréquence naturelle d'oscillation des atomes dans le solide, U_0 est l'énergie de liaison des atomes et γ est proportionnel à la désorientation de la structure moléculaire. En admettant la nature cinétique de la destruction de la liaison, par le mécanisme de fluctuation thermique, la vérification expérimentale directe du phénomène a été obtenue, pour des polymères, par la technique de la résonance paramagnétique des électrons.

ZUSAMMENFASSUNG - Eine Betrachtung der Bruchzeit von einachsigen Spannungsprüflingen aus ungefähr 50 verschiedenen Materialien, gemessen in manchen Fällen über zehn Zeitdekaden, lässt einen allgemeinen Zusammenhang zwischen der Zeit bis zum Bruch (lifetime), der Zugspannung und der Temperatur, der Form

$$\tau = \tau_0 \exp [(U_0 - \gamma\sigma)/kT]$$

vermuten.

Die Konstante τ_0 ist im wesentlichen die reziproke natürliche Schwingungsfrequenz der Atome im Festkörper, U_0 ist die Bindungsenergie zwischen den Atomen, und γ ist proportional der Disorientierung der molekularen Struktur. Unter der Annahme, dass die Bindungszerstörung kinetischer Natur ist und durch Thermofluktuation erfolgt, wurde eine direkte experimentelle Bestätigung der Zusammenhänge bei Polymeren durch Beobachtung der paramagnetischen Elektronenresonanz erhalten.