

ON A TRANSVERSE ABNORMAL GLOW DISCHARGE BETWEEN TWO CYLINDRICAL ELECTRODES IN NITROGEN

By

H. SZCZEPAŃSKA, J. MIZERACZYK

INSTITUTE OF FLUID FLOW MACHINES, POLISH ACADEMY OF SCIENCES
GDAŃSK—WRZESZCZ, POLAND

and

D. VENZKE

CENTRAL INSTITUTE FOR ELECTRON PHYSICS, DEPARTMENT IV, ACADEMY OF SCIENCES OF GDR
1199 BERLIN, GDR

(Received 3. II. 1981)

Measurements of current-voltage characteristics of an abnormal glow discharge between two cylindrical electrodes in nitrogen atmosphere have been made for various cathode filling factors. The characteristics are expressed in analytical form in terms of reduced parameters. The external cases are described by empirical functions agreeing in form with equations reported in the literature referring to plane parallel electrodes and hollow cathode discharges.

I. Introduction

The abnormal glow discharge between two coaxial cylindrical electrodes is of great technological importance. The discharge phenomena occurring in such a configuration correspond to those to be found in industrial plants for ion treatment of steel surfaces in nitrogen atmosphere [1]. In order to optimize the technological process of surface treatment it is necessary to study the physical phenomena occurring in the process and to describe them by mathematical formulae.

Theories developed for various types of abnormal glow discharge, e.g. glow discharge with single plane cathode, the discharge with double cathode consisting of two parallel metallic surfaces, or cylindrical hollow cathode discharge can be found in literature [1, 3, 4, 5].

However, all those examples are of little use in describing conventional glow discharge between two cylindrical electrodes because in this case the discharge conditions differ significantly.

The present work is an attempt of simplified presentation, in terms of reduced discharge parameters, of voltage-current characteristics of abnormal glow discharge between two cylindrical electrodes in nitrogen.

The object of experimental study consisted of two stainless-steel cylinders of different size (one placed coaxially inside the other), the outer being the cathode and the inner being the anode. Several values of anode radii were

tried in the experiment in order to assess how the discharge parameters and current-voltage curves depend on the cathode/anode radius ratio. Since this ratio is the decisive factor determining to what extent the radiation contributes to the generation of charge carriers at the cathode surface we supposed that its changes might effect also the discharge mode and hence its parameters.

II. Experiment

The diagram of the discharge chamber is shown in Fig. 1. The inner diameter of the cathode cylinder R_c was fixed at 23 mm, while the anode cylinders of external diameters R_a equal to 1.5 mm, 5 mm and 16 mm were used alternatively.

The anode-cathode geometry can be described by the filling factor of the cathode volume defined as

$$W = \frac{R_c - R_a}{R_c} . \quad (1)$$

In our experiment the values of W for the three anodes were 0.93; 0.78 and 0.28, respectively.

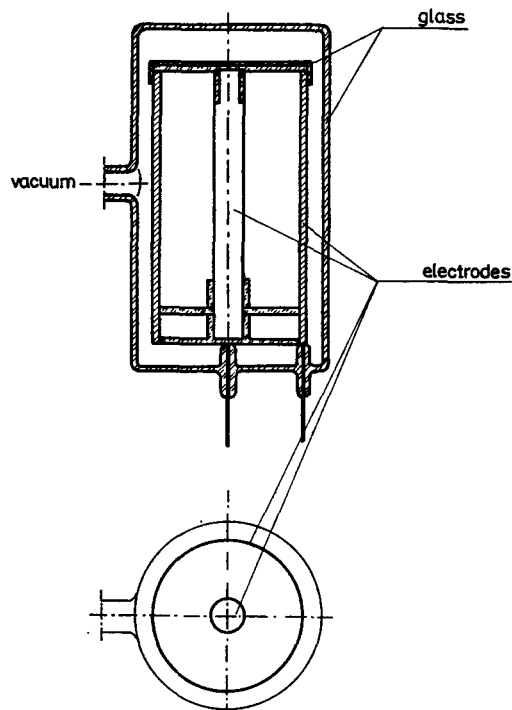

Fig. 1. Scheme of the discharge chamber

The discharge surface was limited by special profiled glass plates at the edges of the cylinders. In this way such phenomena as sparking and generation of an electric arc were avoided.

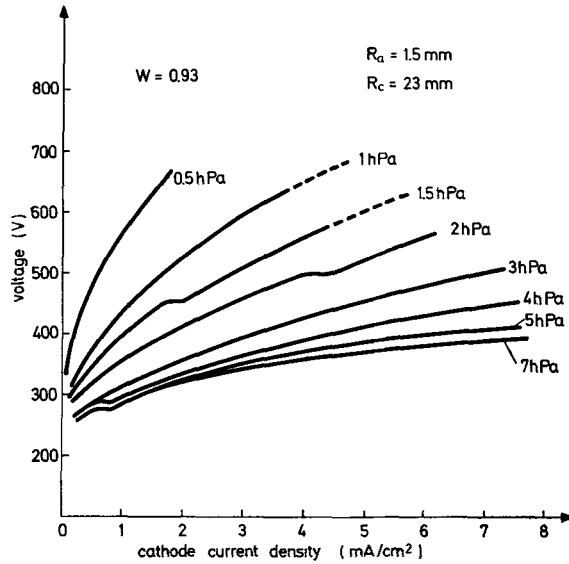

Fig. 2a. Voltage-current characteristics for the filling factor $W = 0.93$

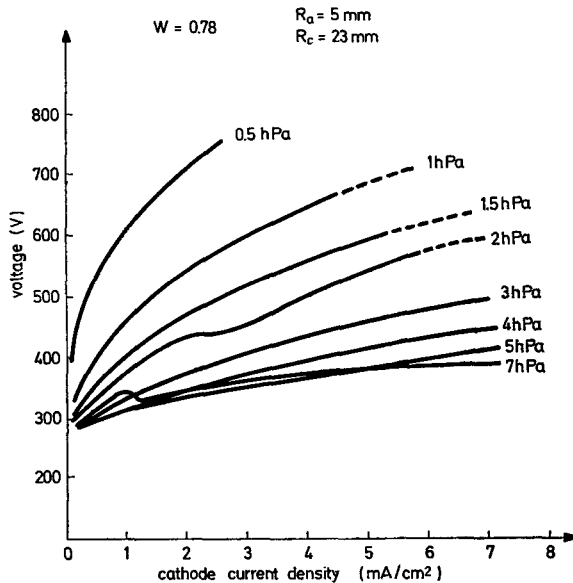

Fig. 2b. Voltage-current characteristics for the filling factor $W = 0.78$

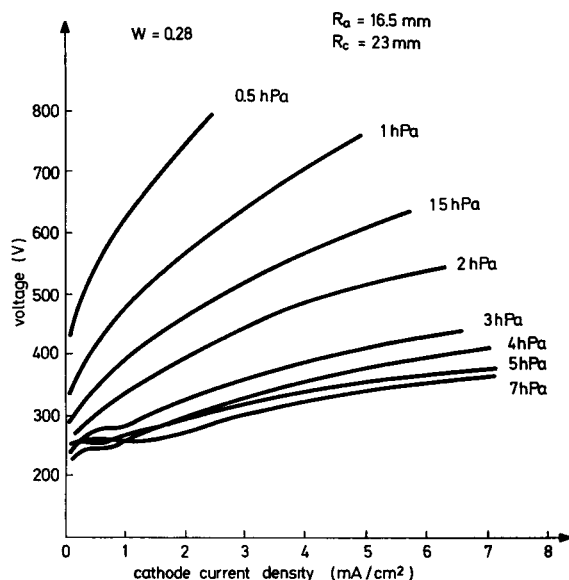

Fig. 2c. Voltage-current characteristics for the filling factor $W = 0.28$

The current-voltage characteristics at various nitrogen pressures were measured in the experiment. As additional data the distribution of radiation along the cathode radius was monitored in order to localize and estimate the thickness of the discharge layers, e.g. cathode dark space, negative glow, etc.

The pressure of spectrally pure nitrogen was varied from 0.5 hPa to 10 hPa and the cathode current density up to $7 \text{ mA}/\text{cm}^2$.

An $x-y$ recorder was used to measure the characteristics. Each measurement lasted not more than 2 s and thus overheating of the cathode was avoided.

The radial distribution of the radiation intensity was assessed by means of a movable spectrophotometer. The current-voltage plots are shown in Figs. 2a, b, c.

III. Discussion

III.1. Generalized description of the discharge characteristics

In the range of parameters involved it was quite reasonable to assume that it was not a big error to assume the voltage U measured between the electrodes to be equal to the cathode fall U_c .

This assumption was justified by the fact that mainly the cathode dark space and negative glow occur in the discharge. In some cases the Faraday dark space and anode glow could also be distinguished. The anode glow

occurred at higher pressures and at rather low values at the current density and disappeared while increasing the latter.

The disappearance of the anode glow was indicated by a drop in the plot of the current-voltage curve (Figs. 2a, b, c). This allowed us to correct the values of cathode fall by subtracting the value of the anode potential drop from the total voltage. The value of anode drop was about 15 V. The voltage of negative glow is usually neglected in comparison to the cathode fall [6].

That is why in further analysis it is assumed that the total operation voltage U measured across the electrodes is equal to the cathode potential fall U_c .

For a more convenient use of the current voltage characteristics the experimental results shown in Figs. 2a, b, c can be presented in log-log scale in terms of reduced current density j/p^2 plotted against the voltage $U = U_c$. An example of such a diagram, for the filling parameter $W = 0.93$ is shown in Fig. 3.

As can be seen from Fig. 3 there is a critical voltage U_{cr} above which the discharge becomes abnormal. This critical value of U_{cr} does not depend on the gas pressure.

All further analysis refers to voltage $U \geq U_{cr}$, i.e. to the abnormal discharge.

From Fig. 3 it can also be seen that the experimental points are distributed along parallel straight lines. These lines have the same slope and intercept the line $U = U_{cr}$ at various points. The straight lines correspond to various pressure of nitrogen. The values of j/p^2 , corresponding to the critical voltage U_{cr} have been denoted as $(j/p^2)_{cr}$.

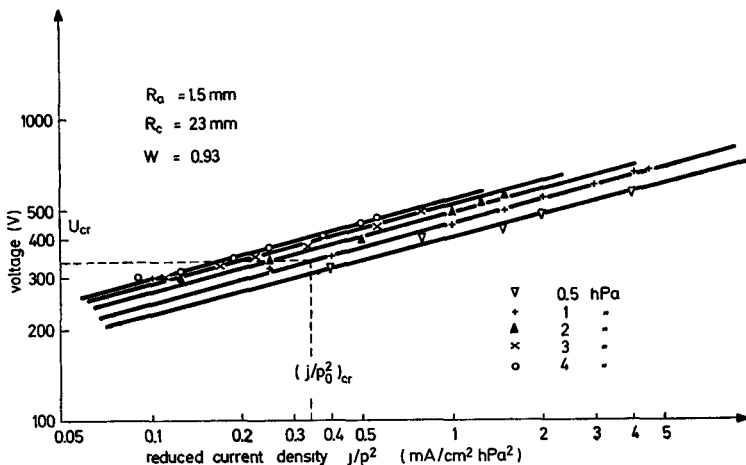

Fig. 3. The cathode fall-reduced current density dependence in log-log scale

From log-log plots of $j/p^2 = f(U)$ dependence it can be found that using the parameters U_{cr} and $(j/p^2)_{cr}$ the following relation

$$U = U_{cr} \left[\frac{j/p^2}{(j/p^2)_{cr}} \right]^{0,25} \quad (2)$$

is valid for all the values of the filling factor W . The critical value $(j/p^2)_{cr}$ is related to pressure and geometrical properties of the electrodes configuration by the equation

$$(j/p^2)_{cr} = (j/p_0^2)_{cr} \left(\frac{P}{P_0} \right)^b, \quad (3)$$

where $(j/p_0^2)_{cr}$ is the reduced critical value of $(j/p^2)_{cr}$ at a pressure $p_0 = 1$ hPa, and b is related to the filling factor W by the equation

$$b = -0.75 W. \quad (4)$$

Values of U_{cr} and $(j/p_0^2)_{cr}$ for various filling factors W are presented in Table I.

Table I
Values of U_{cr} and $(j/p_0^2)_{cr}$

W	U_{cr} (V)	$(j/p_0^2)_{cr}$ (mA/cm ² hPa ²)
0,93	340	0.34
0.78	350	0.32
0.28	280	0.11

Transforming the relation (2) by using the relation (3) one obtains the final formula relating the reduced current density, pressure, cathode fall and the filling factor (expressed here in terms of b)

$$j/p^2 = (j/p_0^2)_{cr} \left(\frac{P}{P_0} \right)^b \left(\frac{U}{U_{cr}} \right)^4. \quad (5)$$

The experimental results of j/p^2 can be compared with the values calculated from the formula (5) in Figs. 4a, b, c. As can be seen from the plots the agreement between the experimental data and our empirical formula is good.

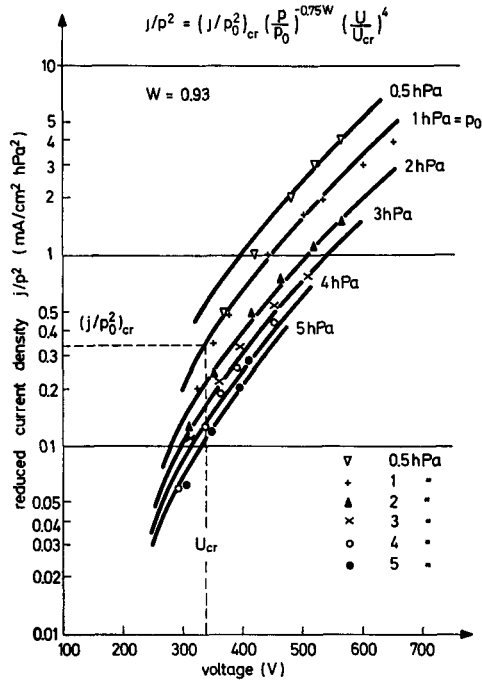

Fig. 4a. Reduced current density as a function of the cathode fall for the filling factor $W = 0.93$

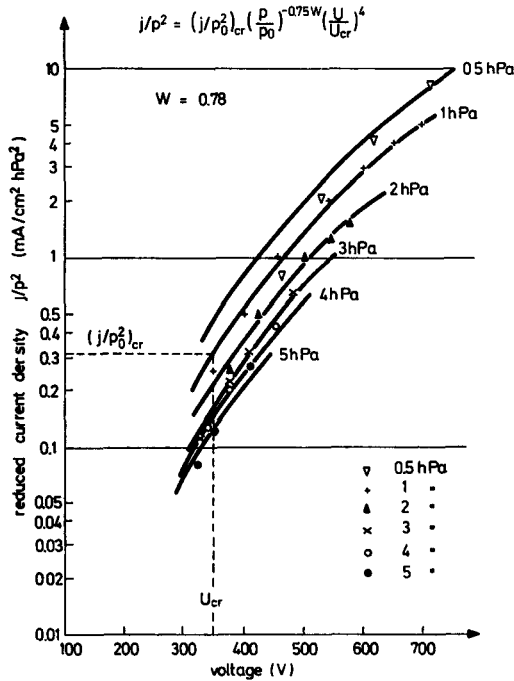

Fig. 4b. Reduced current density as a function of the cathode fall for the filling factor $W = 0.78$

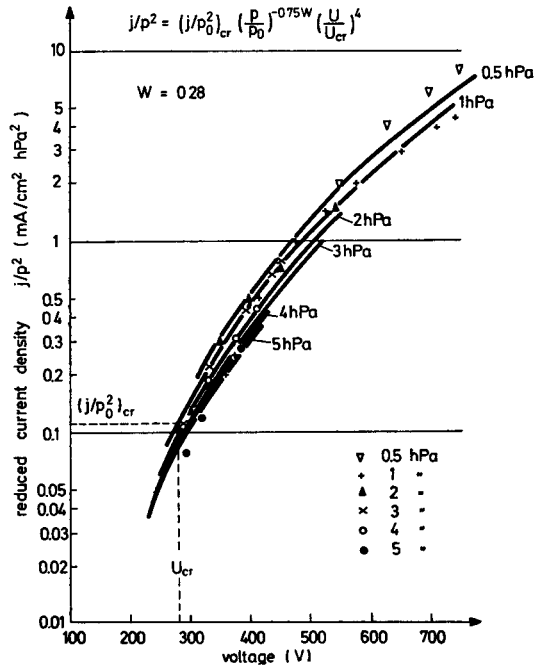

Fig. 4c. Reduced current density as a function of the cathode fall for the filling factor $W = 0.28$

III.2. Extremal cases

The range of values of the filling factor W in our experiment was such that in one extremal case, i.e. when W approaches zero, the mode of the discharge was very close to a glow discharge between parallel plane electrodes and close to a hollow cathode glow discharge, in the other case, when W approaches unity. Thus it was possible to compare our formula with theoretical results obtained by other authors for the above extremal cases.

In order to facilitate the comparison we had determined experimentally through spectroscopic measurements the relation between the cathode potential fall U and the reduced length of the cathode dark space pd as follows

$$U = \frac{A}{pd}, \quad (6)$$

where A is a constant to be equal to 850 V · mm hPa (Fig. 5).

Substituting the expression (6) for U into Eq. (5) we obtain finally

$$j/p^2 = \frac{(j/p_0^2)_{cr} A^{5/2}}{U_{cr}^4} \left(\frac{p}{p_0}\right)^b \frac{U^{3/2}}{(pd)^{5/2}}. \quad (7)$$

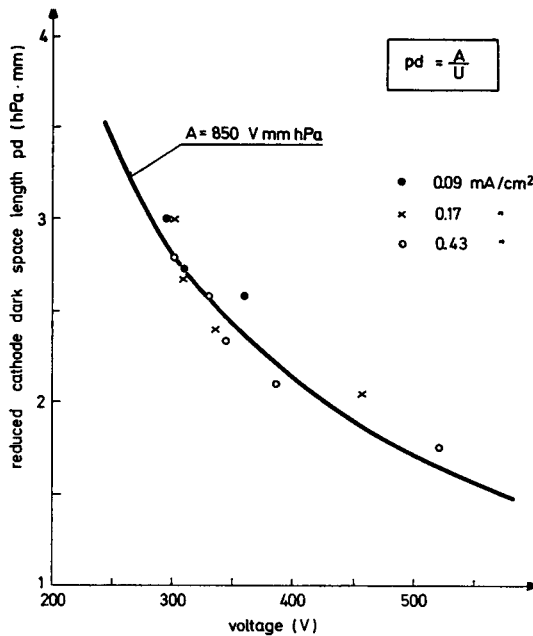

Fig. 5. Reduced cathode dark space length as a function of the cathode fall

The extremal cases of our discharge have been treated theoretically by BADAREU et al [3] and HELM et al [4].

BADAREU et al published the formula relating the parameters of an abnormal glow discharge between two parallel plane electrodes in case of negligible ionization in the cathode dark space as follows

$$j/p^2 = 0.09 \left(\frac{e}{mQ_t} \right)^{1/2} \frac{U^{3/2}}{(pd)^{5/2}}, \quad (8)$$

where e and m are physical constants and Q_t is the charge exchange cross section.

HELM et al have described in analytical form the current-voltage characteristics of a cylindrical hollow cathode discharge in the case of negligible ionization in the cathode dark space using the following formula:

$$j/p^2 = \frac{\varepsilon_0 \cdot k_+ (1 + \gamma)}{F(R, r_0)^{3/2}} \frac{U^{3/2}}{p^{5/2}}, \quad (9)$$

where ε_0 is the vacuum dielectric constant, γ is the coefficient of secondary emission, k_+ is the ion mobility. The function $F(R_0, r_0)^{3/2}$ depends on the geometrical features of the electrodes. For the cathode radius $R_c = 20$ mm

(which is close to that used in our experiment) this function can be approximately expressed by the formula

$$F(R, r_0) = B \cdot d^{5/2}, \quad (10)$$

where B is a constant.

Substituting the expression (10) into Eq. (9) the HELM et al formula relating the hollow cathode discharge parameters for the case of the cathode radius of the order of magnitude of about 20 mm is as follows

$$j/p^2 = \frac{\varepsilon_0 k_+(1 + \gamma)}{B} \frac{U^{3/2}}{(pd)^{5/2}}. \quad (11)$$

A comparison of the above expressions shows that in the case of discharge between two plane electrodes which appears in our experiment when the value of filling factor \mathcal{W} approaches zero, our empirical formula (7) agrees well with the theoretical relation (8), where the reduced current density j/p^2 and reduced length of dark space pd may be regarded as similarity parameters.

In the case of filling factor \mathcal{W} approaching unity (i.e. the discharge being close to the hollow cathode discharge) the comparison of our formula (7) with the theoretical formula (11) exhibits agreement of functional type of relation between U and pd . This agreement is better as the nitrogen pressure approaches 1 hPa since this pressure corresponds to the hollow cathode effect in nitrogen at the given geometry of the electrodes.

The obtained agreements justify the conclusion that the analytical form of the current-voltage characteristics presented in this paper can be also used for describing two extremal cases of glow discharge between two plane electrodes and a hollow cathode discharge.

IV. Summary

The relation between the discharge parameters and the geometrical features of cylindrical electrodes device has been successfully presented in analytical form. The geometrical features of the electrodes are expressed in terms of the filling factor \mathcal{W} . Using that factor made it possible to describe the extremal cases of the configuration, i.e. the discharge between two plane electrodes and the hollow cathode discharge. The quantities j/p^2 and pd employed in the analytical form of the function are not parameters of similarity but may be only regarded as reduced parameters. However, it is justified to use them for describing the discharge as the result can be presented in a clear and convenient form and can be compared with theoretical equations.

REFERENCES

1. T. KARPINSKI A. MARCINIAK and E. ROLINSKI, Schweizer Maschinenmarkt, **78**, Nr 13, 60, 1978.
2. P. F. LITTLE and A. VON ENGEL, Proc. Roy. Soc. London, **A224**, 209, 1954.
3. E. BADAREU, I. POPESCU and I. IOVA, Ann. d. Phys., **5**, 308, 1060.
4. H. HELM, F. HOWORKA and M. PAHL, Z. f. Naturforsch., **27a**, 1417, 1972.
5. H.-E. WAGNER, Untersuchungen an Hohlkathoden — Entladungen in Laval-Düsen. Diplomarbeit Ernst-Moritz-Arndt-Universität, Greifswald, 1973.
6. G. FRANCIS, The Glow Discharge at Low Pressure, Handbuch der Physik. ed., S. Flügge, **XXII**. Springer Verlag, 1956.