

## A Scheme for an Internet-based Checking Method of Machine-Tools with Variant CNC Architecture

**Dong-Hoon Kim\***

*Department of Intelligence and Precision Machines,  
Korea Institute of Machinery and Materials, Daejeon 305-343, Korea*

**Sun-Ho Kim**

*Mechatronics Engineering Major, College of Engineering,  
Dong-Eui University, Busan 614-714, Korea*

**Kwang-Sik Koh**

*School of Electrical Engineering and Computer Science,  
Kyungpook National University, Daegu 702-701, Korea*

This paper proposes an Internet-based checking technique for machine-tools with variant Computerized Numerical Controller (CNC). According to its architecture, CNC is classified into one of two types: Closed Architecture Controller (CAC), which is the conventional CNC, or Open Architecture Controller (OAC), which is a recently introduced PC-based controller. Since CAC has a closed architecture, it is dependent on CNC vendor specification. Because of this, it has been very difficult for users to implement application programs in the CNC domain. Recently, the conventional CNC of machine-tools has been replaced by a PC-based open architecture CNC. However, now many conventional CAC machines are being operated together with OAC machines in inadequately equipped shop floors. For Internet-based checking for variant CNC machines with CAC and OAC, a suitable systematic environment is necessary. Through this research, for the global management of variant CNC machines both a CAC and an OAC in the manufacturing system, a suitable environment for Internet-based checking of variant CNC machines was designed, and the checking methods for CAC and OAC machines were compared. The results of this research may serve as a base model for global monitoring and remote control in an integrated manufacturing system with variant CNC machines. Checking points defined in this research are classified into two categories: structured point and operational point. The former includes the vibration of bearing, temperature of spindle unit, and other points of periodical management, while the latter includes oil checking, clamp locking/unlocking, and machining on/off status.

**Key Words:** Internet-Based Checking Method, Variant CNC, CAC, OAC

### 1. Introduction

Widespread use of computers and the Internet

\* Corresponding Author,

E-mail: kdh680@kimm.re.kr

TEL: +82-42-868-7148; FAX: +82-42-868-7150

Department of Intelligence and Precision Machines,  
Korea Institute of Machinery and Materials, Daejeon  
305-343, Korea. (Manuscript Received June 11, 2004;

Revised October 25, 2004)

have led to a continuously increasing demand for Internet-based control and monitoring of CNC machines for distributed global management in manufacturing systems. In the past, the contact points of Programmable Logic Controller (PLC) were utilized for the monitoring of I/O signals associated with CNC machines and peripheral equipment in manufacturing systems.

However, this solution has been limited to the monitoring of CNC internal information. It has

been difficult to check various monitoring data regarding the CNC, peripheral equipment, and other external units by implementing user-defined programs to the CNC domain (Rober and Shin, 1995 ; Lee et. al., 2004). The required user-defined programs are application modules for the monitoring of CNC machines and for communication with a remote site. Recently, a convenient environment able to implement user-defined programs to a CNC domain for remote monitoring and control has been provided, since the conventional CNC of machine-tools has been replaced by a PC-based open architecture CNC (Rober and Shin, 1995 ; Kwon et. al., 2000 ; Hong et. al., 2003). However, many conventional CAC machines are now being operated in inadequately equipped shop floors. In order to do a remote check on such variant CNC machines, a suitable environment for each case of the CAC and the OAC should be constructed.

We will now briefly outline the related research. Regarding research on the management of machine-tools with open architecture CNC in manufacturing systems, there have been studies on rapid part realization in flexible factory systems (Wright, 1995) and on automatic configuration and dynamic reconfiguration (Oldknow and Yellowley, 2001). A study on switching function generators addressed the maintenance mechanism of machine-tools with open architecture CNC (Kim et al., 2002).

Remote control and monitoring of machine tools by client-server environments has also been investigated (Oldknow and Yellowley, 2001 ; Kim et al., 2003). The representative examples for such remote services are factory windows and remote systems that are developed by a commercial CNC vendor (Kim et al., 2000 ; Kang and Kang, 1999). However, these systems are characterized by basic technical support in local domain environments. Besides of this, as for research on Internet-based management of machine-tools, CNC-implemented fault diagnosis and basic remote services were reported (Kim et al., 2003). Web-based monitoring has been studied in a flexible manufacturing system (Jung et al., 2001). Furthermore, Public Switched Tele-

phone Network (PSTN) and digital I/O modules were utilized for research on the maintenance of CNC machines (Hyun et al., 1998).

However, these researches have focused on only OAC machines except CAC machines and the most service function is to transmit monitoring data via telephone line or external network such as Internet. Although in the case of Internet-based application, a special client-terminal program, which is dependent of developer, has to be installed because the most cases are based on client-server configuration. In some special cases, an additional kernel is optionally required. Besides, the third-party of superior CNC vendor such as Siemens supports partially the web services via Internet. However, in this case, the service functions are not often suitable to the shop-floor and the modification of the functions is very difficult. In domestic case, even representative CNC vendor can not service generally and commercially the Internet-based checking services such as conditions monitoring via Internet. The cause of such actual circumstance mentioned above is because most operators and CNC vendors have focused on the stability and original ability of CNC in domestic CNC market. That is, most CNC vendors are afraid of the breakdown of CNC machine-tools due to overload and faults resulting from additional software installation or upgrade for the purpose of supporting the functions such as remote services. In short, although there are some researches available for machines with OAC, satisfied application cases are rare yet and the studies on machines with CAC have been very deficient. Especially, research on Internet-based checking for variant CNC machines with a CAC and an OAC has not been sufficiently reported due to the inconvenient development environment and inferior software-transportability.

This paper investigates methods for applying Internet-based checking techniques to variant CNC machines with OAC and CAC, and the two types of CNC are compared. And an efficient scheme for Internet-based checking for variant CNC machines is suggested through this study. First, remote checking and control of the digital

signals associated with CAC machines and component parts by using a web I/O embedded module are introduced. Second, this paper considers the remote checking of analog and digital signals associated with OAC machines by implementing user-defined application programs able to interface with an external server to the CNC domain, and by using a Data Acquisition Unit (DAU) able to acquire data connected with the contact points of machines and peripheral equipments.

CAC has a closed architecture which is dependent on CNC vendor specification. Because of this, it has been very difficult for users to implement an application program in CNC. Therefore, a special, additional module is required for Internet-based application (Sena Technologies, 2002). For this, a web I/O embedded module was applied for Internet-based checking in this research. The module is directly attached to the TCP/IP network for communication with a remote site. In order to obtain the monitoring data of CNC machines, the I/O signals of the module were assigned to PLC I/O signals within CNC. On the other hand, OAC has a PC-based open architecture that operates independent of CNC vendor specification and no additional module is necessary for connection with a remote site. Because of this, a simple DAU, which is not directly attached to OAC main-board and not directly affects to CNC stability, is used for signal sensing and data acquisition via RS232/422 line without additional communication device module. For Internet-based remote checking of machine-tools with OAC, a user-defined daemon for communication and application programs for web services were implemented in the form of internal function within OAC and an external server. Internet communication is performed between the daemon program of the CNC domain and web script programs of the external server.

## 2. Structure of Variant CNC Machines and Remote Checking Directions

As mentioned above, the implementation of a

user-defined application program is much more difficult in the CAC than in the OAC due to the inconvenient development environment of the CAC. Because the CAC is fully dependent on the CNC vendor, as shown in Fig. 1(a), the CAC cannot support the application of user-functions that can connect with the network and remotely check CNC machines in the CNC domain. However, as shown in Fig. 1(b), it is convenient for users to implement the application programs for remote checking in the OAC domain because the OAC has an open architecture based on a PC. For Internet-based remote checking of these two CNC machines that are operated together in a manufacturing system, a suitable system environment must be constructed according to the structure characters of the variant CNC. The conventional CAC with closed architecture can efficiently use the network-supported unit with embedded web server functions because connecting the I/O signals of the applied unit with the I/O signals of CNC machines is possible. This method has an relatively simple system architecture for users, but its fatal flaw is that it cannot manage multiple CNC machines simultaneously with a single server and web script program ; this method, using web-server functions embedded in the device, requires that an individual Internet Protocol (IP) address be associated with each machine.

For the recently popularized OAC with a

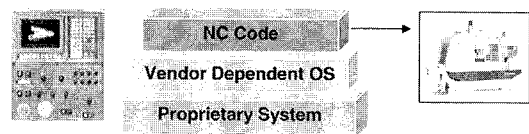

(a) CNC with closed architecture controller

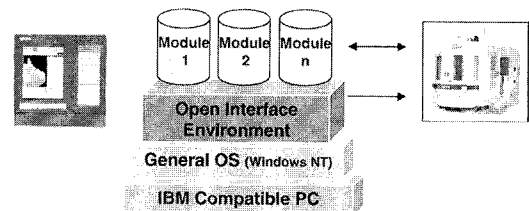

(b) CNC with open architecture controller

**Fig. 1** Structure of variant CNC machines

PC-based open architecture environment, instead of using network-supported units that require additional unique IP addresses, a suitable method is as follows. First, a DAU is utilized in order to acquire I/O data. Then the application program for data acquisition is implemented in order to check I/O contact signals through the DAU, and the interface daemon program, that can transmit the acquired data from a CNC domain to an external server, is implemented in the CNC domain. A particularly outstanding merit of this system is that a lot of CNC machines can be monitored and managed simultaneously without an additional device with embedded web-server functions. This method also has good expansibility.

### 3. Definition of Checking Points

As shown in Table 1, the checking points defined in this research are classified into two categories: structured point and operational point. The former includes the vibration of bearing, and the temperature of the spindle unit and other specific units, while the latter includes oil checking, clamp locking/unlocking, and other digital checking points associated with machine operations.

**Table 1** Definition of checking point

Structured Conditions	Operational Conditions
Vibration of bearings	Machining On
Temperature of spindle	Machining Off
Vibration of bearing2	Fault (No Ready)
Temperature of spindle2	Oil checking
Vibration of bearing3	Clamp lock/unlock
Temperature of spindle3	Sub unit on/off

### 4. Internet-Based Checking Method for CAC Machines

This section describes the application of an Internet-based checking method for CAC machines. In remote monitoring of checked results

and related information with CAC machines, the application program implementation and the program running environment in the CNC domain are more limited than in an OAC environment that can easily implement software functions. Because an additional device module is necessary, we utilized the I/O module with embedded minimum operating system and web server functions, as shown in Fig. 2. By applying this module, the control and monitoring of CNC machines were remotely performed in the experiment. The applied device module supports a total of 32 I/O contact points in order to interface with external devices. The contact points were connected with the PLC I/O signals of the CAC machine. Through these points, the machine status such as cycle start, stop, emergency stop, and machining on/off status can actually be monitored in a web environment.

The procedure for the application test is as follows. The icons associated with the I/O device module are first designed in default html source by using the supplied device utility, and then the icons' properties are assigned to specific I/O addresses. Next, network-supported java class is inserted in default html source and the source codes are compiled by the utility compiler. After that, coded web script files are transferred to the specific file index format so that they can be interpreted by the device module engine (Sena

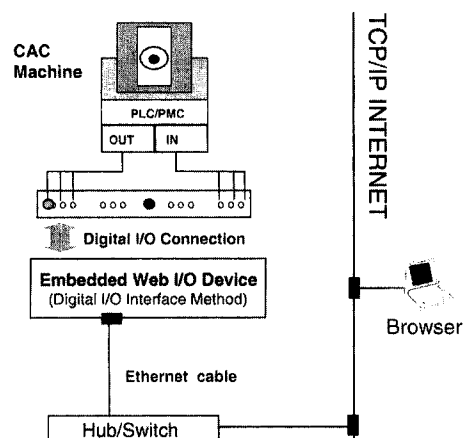

**Fig. 2** Internet-based checking configuration using embedded web I/O device for CAC machine

Technologies, 2002). The transferred file, that is in the form of a specific format, is a single image file format that is downloaded to flash memory, as shown in Fig. 3. In order to assign the physical I/O device addresses in application source codes, the real I/O addresses are mapped with the icon properties in web script sources such as html, vbscript, and javascript, as shown in Fig. 4.

Fig. 5 shows that the status of the CAC machine is now checked as machining-on when the cycle-start button is selected through a web browser. And through additional analog checking experiment for structured conditions, bearing vibration and spindle temperature were monitored in real time. The remote checking model of the CAC machine and its implementation method are relatively simple and convenient, but a database and large-scale script files cannot be loaded. In

detail, a maximum 512 Kbytes application script program can be downloaded to the web I/O embedded device module. However, this method can be very efficient in applications as it uses an I/O board independent of other systems. Here, for remote checking, web script was coded by using java applet and was downloaded to the web I/O embedded device module. For interfacing with the I/O of the CNC machine, I/O contact points were directly connected with each other between the embedded web I/O device and the machine I/O signals. Test results confirmed that the application system environment can be easily designed by using this checking method.

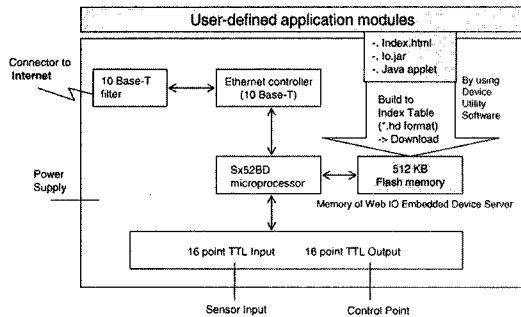

Fig. 3 Interface between embedded web I/O device and application program

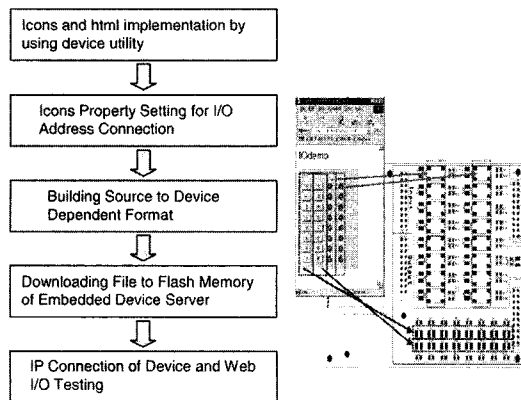

Fig. 4 Address setting and testing of web I/O device

Table 2 Hardware specification of used web I/O device

Item	Content
CPU	8-bit Microprocessor
Memory	512 KB Flash Memory (User Web File/Parameter App.)
Network Connection	10-base T Ethernet (IEEE802.3)
External Connection	16 point Digital Input, 16 point Digital Output
Internet Protocol	HTTP/TCP/UDP/IP/Ethernet
Utility software	Board (Vendor) Dependency, IP Setting/Web Page Uploading

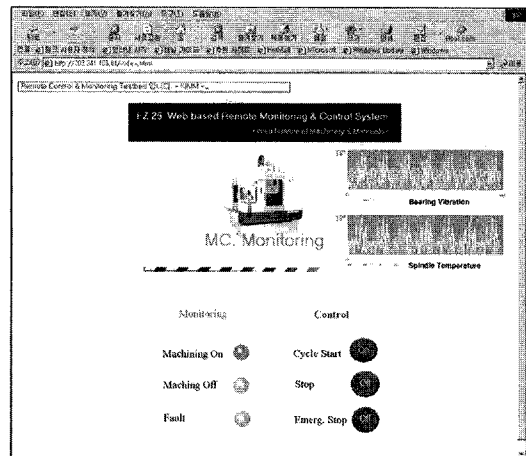

Fig. 5 Checking for CAC machine by using embedded device server

### 5. Internet-Based Checking Method for OAC Machines

In the case of the OAC, an additional device module for network support is not required, as the OAC has a convenient structure that can implement network application programs. To check and acquire machine I/O signal data, only a signal processing board or external DAU for data acquisition is needed. As most OAC is based on a single board computer with a compact architecture, a DAU that can simply connect I/O signals is more efficient than the board type (Advantech, 2002). The application of a checking method that can notify the checking time and the replacement time of component parts was tried by monitoring of machining status, temperature, and vibration of component parts through the DAU. Through this application, the analog and digital contact points of CNC machines and peripheral units were monitored by using the DAU. In the experiment, an external I/O DAU module was used in order to reduce hardware device sizes and minimize the load. The Internet-based checking configuration using DAU for an OAC machine is shown in Fig. 6. RS485 communication was internally performed through RS232/485 conversion specification. A range of 0V to 1.5V was assigned and a sampling period was assigned as 10 times per second in order to acquire analog transferred values. For the experiment for acquiring bearing vibration and spindle temperature,

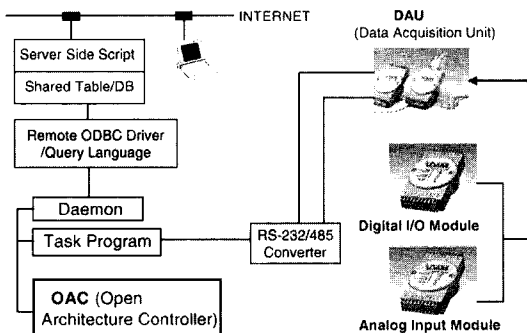

Fig. 6 Internet-based checking configuration using DAU for OAC machine

the transferred analog values were monitored in real time by the designed communication protocol between OAC and DAU, as shown in Fig. 7. Subsequently, the basic experiment for checking on/off status of oil and clamp was also performed, as shown in Fig. 8. The functional application codes were implemented as the internal function of the CNC domain in the OAC.

For the Internet-based checking application, the developed daemon program for communication was implemented in the CNC domain, and the web script program for web services was implemented in an external server by using vbscript, javascript, and Active Server Page (ASP), as shown in Fig. 9. Internet communication can be performed between the daemon program in the CNC domain and the external web script

Analog Input Module (ADAM-4018)		
%AA#NTTCFF	Configuration	Set Address(AA), Input Range(TT), Baud-Rate, Data Format, Check Sum etc.
#AA#N	Read Analog Input from Channel N	Return the Input Value from Channels No. N of the Specified Analog Input Module
#AA	Read Analog Input from All Channels	Return the Input Value from All Channels of the Specified Analog Input Module
Continued . . . . .	. . . . .	. . . . .
Digital I/O Module (ADAM-4050,4052)		
%AA#NTTCFF	Configuration	Set Address, Baud Rate, and/or Checksum status, to a digital I/O Module
\$AA#	Digital Data In	Return the values of Digital I/O Channels of the addressed module
#AABB(data)	Digital Data Out	Write specified values to either a single channel or all channels simultaneously
Continued . . . . .	. . . . .	. . . . .

Fig. 7 Communication protocol between OAC and DAU module

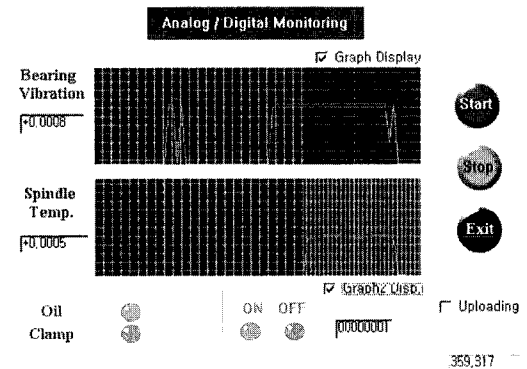

Fig. 8 Acquisition of analog input (0-1.5V Range) and digital input (8bit DI)

program. Therefore, multiple clients can monitor the checked data and machine status by transmitting acquired digital and analog data from the OAC to the external database. The CNC daemon program for communication utilizes standard Open Database Connectivity (ODBC) and the data processing utilizes the query of Structured Query Language (SQL). Through this process, the table information associated with transmitted checking data was constructed in database tables. Remote checking in the Internet environment was realized through the designed applica-

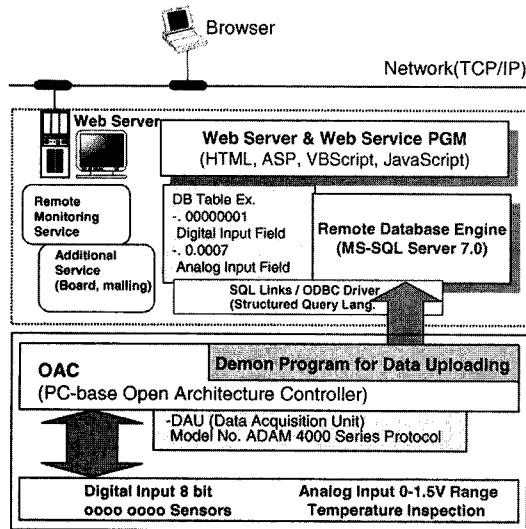

Fig. 9 Interface between OAC and application program of web sever

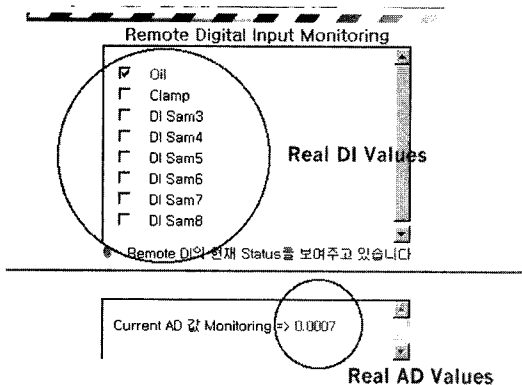

Fig. 10 Checking for OAC machine by using DAU and application program

tion programs, as shown in Fig. 10. Results show that this checking method is advantageous in that its convenient development environment in terms of software can easily implement user-defined application programs.

## 6. Scheme and Example of Internet-Based Checking for Variant CNC Machines

The scheme for Internet-based checking for variant CNC machines is suggested in Fig. 11. The CAC machine area is designed to check digital data by using downloaded script codes and the I/O interface mechanism of the embedded

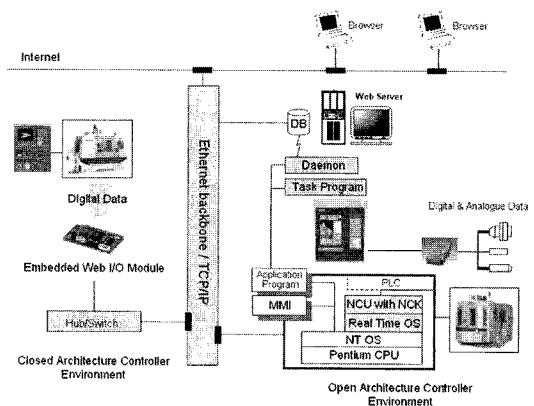

Fig. 11 Internet-based checking environment for variant CNC machines

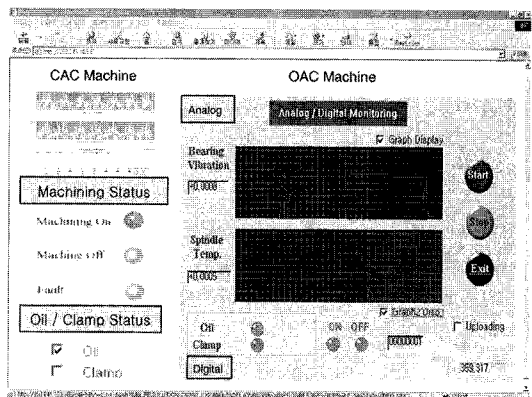

Fig. 12 Example of Internet-based remote checking for variant CNC machines

device server. The OAC machine area is designed to check analog data and digital data by using DAU and application programs such as a data acquisition module, a communication daemon module, and a web script module. The Internet-based remote checking for variant CNC machines through the proposed scheme is demonstrated in Fig. 12.

In the case of the CAC machine, a java applet was coded and downloaded in order to check the machine I/O data and to provide the checked result to clients through a web browser. The I/O addresses assigned between the java applet codes and the real I/O points of the machines was monitored and controlled from a remote site. The demonstrated content is the result of monitoring the I/O contact points associated with current machining on/off status. The CAC machine is now being operated by a cycle start button on a web browser.

In the case of the OAC machine, the acquired monitoring data from DAU were transmitted to an external server by the communication daemon and were serviced in a remote site. It was confirmed through a web browser that an oil sensor was activated and that the spindle temperature was 0.0007 (which is the analog value with the range from 0 to 1.5 V).

Results show that the former case, CAC, is advantageous in that it can easily realize the Internet-based checking system by utilizing the web-function embedded device in the hardware. However, the maximum sizes of the user-defined application programs and the downloading data are limited to 512 Kbytes. The latter case has merit in that its convenient development environment can easily implement many various application programs in the CNC domain without additional devices. However, user-defined application programming works for the purpose of implementing communications and web services are required more than in the former case

## 7. Conclusion

This paper proposes a new scheme for Internet-based checking for variant CNC machines

with both the conventional CAC and the recently popularized OAC in the machine shop-floor. For efficient Internet-based checking of CAC machines, a signal checking method using a web I/O embedded device module that can support Internet application environment was suggested because of the difficulties involved in implementing user-defined application programs to a CNC domain in which the CAC environment is dependent on CNC vendor specification.

For Internet-based checking of OAC machines, the digital and analog signals checking method, which does not require additional web I/O embedded devices for Internet application, was suggested because implementing user-defined application programs to the CNC domain is easy due to the convenient OAC environment. This method simply utilized DAU to acquire I/O data in hardware respect and the acquired data were transmitted to an external server for remote checking through a web browser at a remote site.

Subsequently, the checking methods for CAC and OAC machines were compared. Through this research, for the global management of CNC machines with variant CNC architecture such as a CAC and an OAC in manufacturing system, a suitable environment for Internet-based checking of variant CNC machines was designed for an integrated operation. The results of this research may be a base model for global monitoring and remote control in integrated manufacturing systems with variant CNC machines.

Future work should tackle the following problems. First, researchers should investigate the design and realization of a superior remote checking environment that can utilize sufficient downloading codes in the embedded device. Second, further research is needed on the standardization and development of optimized application programs that can more simply integrate and operate variant CNC machines.

## Acknowledgment

The authors would like to acknowledge the financial support provided by the Industrial Renovation Technology Project (The Ministry of



Commerce, Industry, and Energy).

## References

Advantech, 2002, Total Solution for PC-based Automation, Solution Guide Vol. 20.

Hong, W. P., Lee, S. W., Choi, H. Z. and Yang, M. Y., 2003, "Simultaneous 3D Machining with Real-Time NURBS Interpolation," *KSME International Journal*, Vol. 17, No. 3, pp. 336~342.

Hyun, W. K., Chung, S. C. and Shin, D. S., 1998, "Remote Fault Diagnosis and Maintenance System for NC Machine Tools," *Journal of KSPE*, Vol. 15, No. 1, pp. 19~25.

Jung, M. S., Park, H. S. and Kim, B. S., 2001, "Architecture of Web-based Real-time Monitoring System," *Journal of ICASE*, Vol. 7, No. 7, pp. 632~639.

Kang, D. C. and Kang, M. J., 1999, "A Study on an Internet-based Remote Diagnosis System for Machine-Tool Failures," *Journal of KSPE*, Vol. 16, No. 9, pp. 75~81.

Kim, D. H. et al., 2002, "Development of Switching Function Generator for Fault Reasons of CNC Machine-Tool," *Proceeding of KSMTE Spring Conference*, pp. 48~52.

Kim, D. H., Kim, D. Y., Kim, S. H. and Koh, K. S., 2003, "Web Service Application for Machine-Tool Failure with Open Architecture CNC," *Proceeding of KSPE Spring Conference*,

pp. 29~32.

Kim, S. H., Kim, D. H. and Park, K. T., 2000, "Open Manufacturing System using MMS Service and Object Oriented Manufacturing Devices," *Journal of KSPE*, Vol. 17, No. 10, pp. 41~48.

Kwon, Y. C., Han, G. S. and Kim, J. H., 2000, "The Implementation of Modularized Open CNC," *Journal of KSPE*, Vol. 17, No. 5, pp. 34~40.

Lee, D. J., Kim, S. H. and Ahn, J. H., 2004, "Breakage Detection of Small-Diameter Tap Using Vision System in High-Speed Tapping Machine with Open Architecture Controller," *KSME International Journal*, Vol. 18, No. 7, pp. 1055~1061.

Oldknow, K. D. and Yellowley, I., 2001, "Design, Implementation and Validation of a System for the Dynamic Reconfiguration of Open Architecture Machine Tool Controls," *International Journal of Machine Tools & Manufacture*, Vol. 41, pp. 795~808.

Rober, S. J. and Shin, Y. C., 1995, "Modeling and Control of CNC Machines using a PC-based Open Architecture Controller," *Mechatronics*, Vol. 5, No. 4, pp. 401~420.

Sena Technologies, 2000, Starter Kit for Hello Device.

Wright, P. K., 1995, "Principles of Open-Architecture Manufacturing," *Journal of Manufacturing Systems*, Vol. 14, No. 3, pp. 187~202.