

Removal of Phenolic Compounds by Electro-assisted Advanced Process for Wastewater Purification

Zucheng Wu[†], Yanqing Cong, Minghua Zhou, Qian Ye and Tianen Tan

Department of Environmental Engineering, Zhejiang University, Hangzhou 310027, China
(Received 5 April 2002 • accepted 20 June 2002)

Abstract—Electro-assisted advanced process was developed for wastewater treatment of phenolic compounds. A series of correlative experiments were carried out: the degradation of phenol by the advanced electrochemical oxidation process, the degradation of chlorophenol by the photo-electrocatalysis, and the degradation of chlorophenol by pair electrodes. It was found that phenol and chlorophenol could be removed rapidly and effectively at initial concentration of 100-400 mg L⁻¹, current density of 3.2-27.5 mA cm⁻², and applied voltage of 2-5 V. The combination of electrocatalytic and UV radiation greatly accelerated the removal efficiency. The dechlorination of chlorophenol could be achieved under cathodic reduction so that it could be further oxidized more quickly and completely. The mechanism of dechlorination was proposed to be the indirect dechlorination by atomic hydrogen. The electro-assisted advanced processes were suitable for the treatment of the phenolic compounds.

Key words: Electro-assisted Process, Chlorophenol, Dechlorination, Phenolic Compounds, Degradation

INTRODUCTION

Wastewater containing phenolic pollutants has been found in many industries, such as oil refineries, chemical and plastic plants. As is well known, those compounds are toxic even at low concentration [Verschueren, 1977], and they are the representatives of aromatic compounds. Especially for chlorinated phenols (CPs), they are widely found in the environment and are significant contaminants at many sites selected for cleanup on the USEPA priorities list of the superfund program [Lin and Tseng, 1999]. It is very important to treat such contaminants; therefore, chlorophenol and phenol were chosen as model pollutants in our work.

The method for treating phenolic compounds encompasses investigations of advanced oxidation processes (AOPs), which are characterized by production of the hydroxyl radical ($\cdot\text{OH}$) as a primary oxidant to remove organic matters and to purify water for its recovery. Examples of AOPs include the use of UV/H₂O₂, UV/O₃, UV-Fenton, electrochemical oxidation and etc. [Choi et al., 2001; Park et al., 2001]. Some of these AOPs have been applied for practical use in industrial wastewater treatment, and others have still been investigated.

Advanced Electrochemical Oxidation Processes (AEOPs) are newly developed AOPs that have attracted many investigators [Lee et al., 1999; Comninellis and Nerini, 1995; Lee and Langer, 1995; Rajeshwar et al., 1994]. They can produce hydroxyl radicals directly or indirectly by electrode reactions that have catalytic activity at normal temperature and atmospheric pressure, and thereby can degrade the wastes that cannot be treated by biological action [Grega et al., 1994]. AEOPs provide the promising approaches for sustainable development and the prevention of pollution problems. The inherent advantage is its environmental compatibility for the fact that the main reagent, the electron, is a "clean reagent." In addition,

it is also attractive because of its versatility in treating various wastewater, amenability to automation, and high selectivity to prevent the production of unwanted by-products [Juttner et al., 2000].

The objective of this paper was to explore the possibility of water purification by using an electro-assisted advanced process to remove phenolic compounds from wastewater. A series of correlative experiments were carried out: the degradation of phenol by the advanced electrochemical oxidation process; the degradation of chlorophenol by the photo-electrocatalysis; the degradation of chlorophenol by pair electrodes. The relationships among them were discussed.

EXPERIMENTAL

1. Apparatus

During the degradation of phenol by the electrochemical oxidation process, the anode of $\beta\text{-PbO}_2$ and the cathode of Ni-Cr-Ti alloy grid (20 mesh) were concentrically assembled into the undivided electrolytic reactor with final volume of about 0.33 dm³. The anode used here was a modified $\beta\text{-PbO}_2$ electrode ($\Phi 45 \times 200$ mm), which was co-deposited with fluorine resin on a cylindrical ceramic tube. The details of the anode preparation were given in our previous work [Wu and Zhou, 2001]. The supporting electrolyte of 1 g L⁻¹ Na₂SO₄ and a certain concentration of phenol pollutant was pumped through the reactor and then returned to the reservoir for recycling. The reservoir was placed in a water bath to regulate the reaction temperature desired. Constant current was maintained at the desired level with only minor adjustments of the applied voltage.

During the degradation of chlorophenol by the photo-electrocatalysis, the wastewater containing a certain concentration of chlorophenol compounds and supporting electrolytes were circulated between the electrocatalytic cell and the photo-reactor by a circulating pump. The schematic diagram of the experimental setup is shown in Fig. 1. Irradiation was achieved by using an 8W UV lamp with main wavelengths 254 nm. The lamp was covered by a cylindrical immersion tube, which is made of a quartz glass that has a

[†]To whom correspondence should be addressed.
E-mail: wuzc@zju.edu.cn

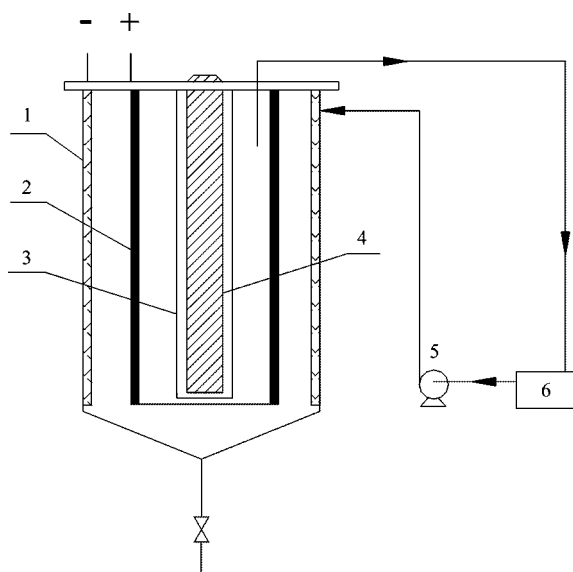

Fig. 1. Schematic diagram of the photo-electrocatalysis.

- | | |
|----------------|--------------|
| 1. Cathode | 4. UV lamp |
| 2. Anode | 5. Pump |
| 3. Quartz tube | 6. Reservoir |

high transmission for UV light. The volume of the electrocatalytic cell was about 1,000 ml. The others were the same as the above.

During the degradation of chlorophenol by pair electrodes, the electrolytic cell of the reactor was divided into three parts by two perpendicular table-flaps. The simulated wastewater was circulated around the table-flaps between the cell and the reservoir by a circulating pump. The anode and cathode were installed in both sides and no electrode was in the middle part. The wastewater flowed into the cathodic region, then passed through the middle part, and entered the anodic region in sequence. The cathode used here was nickel, which has high hydrogen over-potential and is a good catalyst in the hydrogenation reaction. The anode was carbon.

2. Analysis

During each run, samples were taken from the sampling port in the reactor for analysis at appropriate intervals. Analyses of model pollutants and their intermediate products were carried out on a high-performance liquid chromatograph (HPLC, Gilson, France). Aliquots of 25 μL were injected to the HPLC, running with mobile phase of acetonitrile, water, and an additional 2 ml of concentrated H_3PO_4 per liter of solution. The separation was performed by using an ODS-18 reversed phase column (Alltech, USA) at the flowrate of 1.5 mL min^{-1} and column temperature of 25 $^\circ\text{C}$. A UV detector was used with the wavelength set at 254 nm. Organic acids were determined by ion chromatography (IC, Alltech, USA and/or IC 1000 Techcomp, Shanghai) with a mobile phase of sodium carbonate (0.85 mmol L^{-1})/sodium bicarbonate (0.9 mmol L^{-1}) at a flowrate of 1.5 mL min^{-1} . The detector was an Alltech 550 conductivity detector at 35 $^\circ\text{C}$. The COD (chemical oxygen demand) was determined according to the standard methods for examination of water and wastewater [APHA, 1995].

RESULTS AND DISCUSSION

1. To Remove Phenol from Wastewater

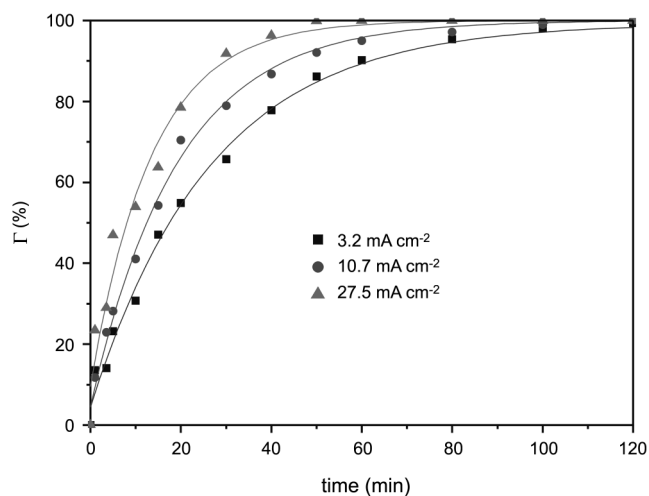

Fig. 2. Effect of current density on phenol removal efficiency. Operational conditions: initial phenol concentration 100 mg L^{-1} ; circulating rate 1,800 mL min^{-1} ; K_2SO_4 1.0 g L^{-1} ; temperature 25 $^\circ\text{C}$; pH 5.6.

Fig. 2 shows the effect of current density on phenol degradation efficiency. From the figure, it can be seen that the increase of current density greatly accelerated the removal rate of phenol. When the current density is 27.5 mA cm^{-2} , the phenol is almost removed after 60 min treatment; while when the current density is 3.2 mA cm^{-2} , the phenol cannot be removed until 120 min treatment. After 40 min treatment, the removal efficiency is about 77%, 85%, 95% at a current density of 3.2 mA cm^{-2} , 10.7 mA cm^{-2} , and 27.5 mA cm^{-2} , respectively. Therefore phenol removal will be faster at higher current density.

Fig. 3 shows the effect of initial phenol concentration on the phenol degradation efficiency. From the figure, it can be seen that low initial phenol concentration resulted in higher removal rate. After 90 min treatment, the removal efficiency at 100 mg L^{-1} initial concentration can reach 92%, while it is only 68% for 400 mg L^{-1} . Such

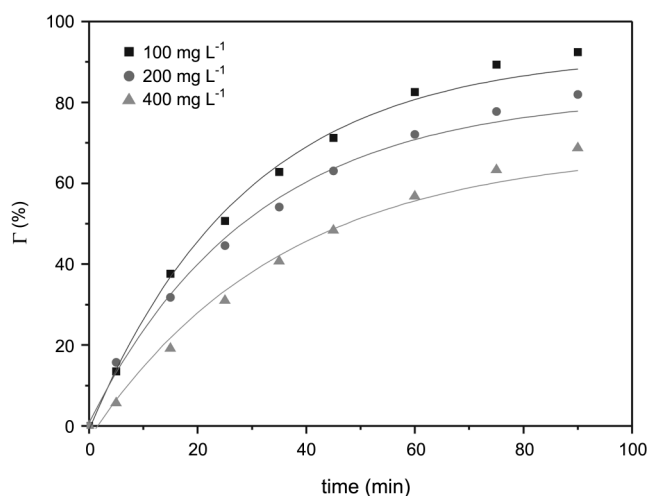

Fig. 3. Effect of initial phenol concentration on phenol removal efficiency. Operational conditions: circulating rate 1,800 mL min^{-1} ; temperature 25 $^\circ\text{C}$; K_2SO_4 1.0 g L^{-1} ; current density 7.5 mA cm^{-2} ; pH 5.6.

a decrease in the phenol removal efficiency is apparently attributable to an increase in the oxidation load at high initial phenol concentration. However, a large amount of phenol can be removed at higher initial concentration. The total phenol removal is 92 mg L^{-1} for a 100 mg L^{-1} initial concentration at 90 min treatment, for example, while it reaches 272 mg L^{-1} for a 400 mg L^{-1} solution. In view of this, the oxidation process would be suitable for the treatment of higher concentration pollutants.

Benzoquinone (BQ) and aliphatic carboxylic acids such as maleic acid and oxalic acid are the main intermediates of phenol degradation. Practically, the complete oxidation of phenol to carbon dioxide by electrochemical treatment will not be economical due to high-energy consumption. Partial oxidation of phenol was suggested [Wu and Zhou, 2001]—that a ring opening reaction of phenol could result in organic acids of a biological nutrient, which requires less energy consumption. Thus, the partial oxidation of phenol will provide us a valuable pretreatment technique for subsequent cheap biological treatment.

2. The Degradation of Chlorophenol by the Photo-electrocatalysis

Photocatalysis is one of the most investigated AOPs. It is very effective on degrading many organic pollutants [Hugul et al., 1999; Chen et al., 1997; Lu and Chen, 1997]. Recently, it has been a trend that some combined processes of AOPs are used to treat the wastewater. To achieve synergetic effects, a combined process of photo-electrocatalysis was employed to accelerate the chlorophenol removal.

Three different processes (individual photocatalysis, individual electrocatalysis, and their combination) were used to degrade the wastewater containing the chlorophenol. Fig. 4 shows the change of COD with time. As shown in Fig. 4, it is obvious that the process of the combination has a better effect than the individual process. After 120 min treatment, the COD decreases from 162 mg L^{-1} to 19 mg L^{-1} , and about 90% COD is removed for the combination of electrocatalysis and photocatalysis. Whereas, the COD removal rate is only 26% for the individual photocatalysis and it is 47% for the individual electrocatalysis. It is evident that the combined process of electrocatalytic and photocatalysis has synergetic

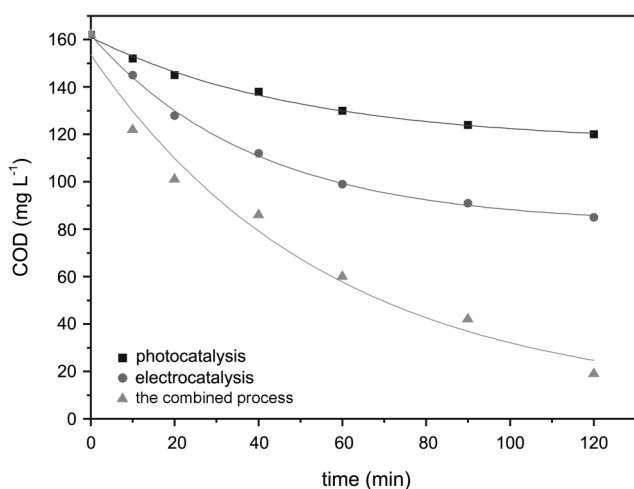

Fig. 4. The comparison of three processes. Operational conditions: initial chlorophenol 100 mg L^{-1} ; pH 6.5; K_2SO_4 5 g L^{-1} ; volume $1,000 \text{ ml}$.

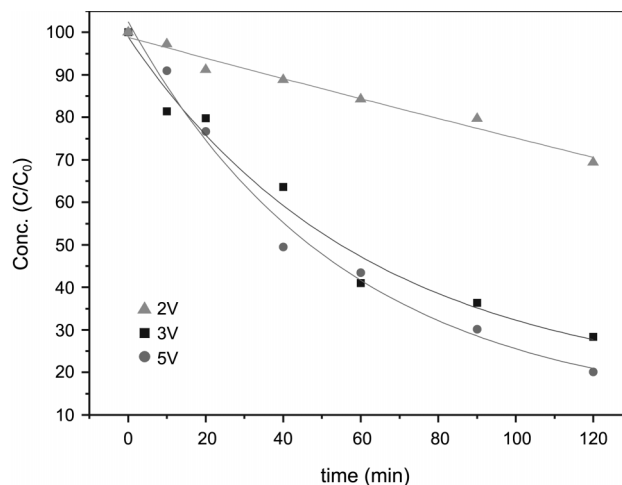

Fig. 5. Effect of voltage on chlorophenol removal. Operational conditions: initial chlorophenol 50 mg L^{-1} ; pH 6.5; volume $1,000 \text{ ml}$; K_2SO_4 5 g L^{-1} ; operated with anodic-cathodic electrocatalysis.

effects in improving the rate of chlorophenol removal in contrast with the individual photocatalysis or individual electrocatalysis. The possible mechanism for the synergetic effects is the electrochemical generation of active species such as H_2O_2 that are further turned into strong oxidant of hydroxyl radicals under the irradiation of UV, and therefore phenolic compounds can be degraded more effectively and rapidly [Zhou et al., 2002].

Fig. 5 shows the effects of applied voltage on chlorophenol removal. From the figure, it can be seen that higher voltage has remarkable effect on the degradation of chlorophenol. At 2 V, the removal rate of chlorophenol is slow and the efficiency is only 28% after 120 min treatment. The removal efficiency can reach 80% at 5 V in the same time. However, the efficiency increased insignificantly when voltage reached a certain level. From Fig. 5, it can be seen that the removal efficiency at 5 V is close to that at 3 V. The energy consumption will be higher by applying higher voltage. Thus, the observations suggested that it is important to operate in a reasonable voltage range to improve the current efficiency.

The combinative photo-electrocatalysis proved to have synergetic effects in enhancing the rate of chlorophenol removal rate, and it was certainly a positive method for achieving quick mineralization. The combined process provided a novel alternative to the rapid degradation of biorefractory compounds for wastewater treatment.

3. The Degradation of Chlorophenol by Pair Electrodes

Chlorophenol is difficult to degrade because of the existence of chlorine. Oxidation could destroy the phenyl and make the chlorinated aromatic compounds degraded, but incomplete dechlorination is an annoying problem because the incomplete dechlorination indicates the presence of chlorinated intermediates, in which chlorine could still be bound in aliphatic structure [Hirvonen et al., 2000]. It is very possible that the toxicity of the compounds does not decrease or even increase. To avoid this secondary pollution, it is a wonderful method to completely dechlorinate by cathodic reduction before the chlorinated compounds are oxidized.

Fig. 6 shows the effects of current on the degradation of chlo-

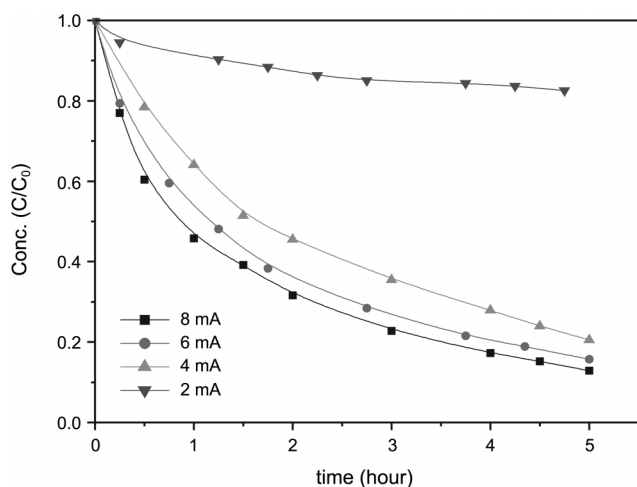

Fig. 6. The effect of current on the degradation of chlorophenol. Operating conditions: initial chlorophenol concentration 100 mg/L; pH 6; Na₂SO₄ 5 g/L; volume 60 ml.

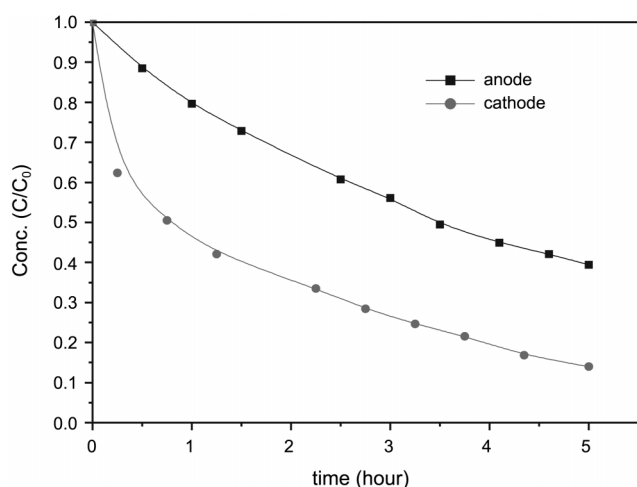

Fig. 7. Chlorophenol degradation on anode and cathode. Operating conditions: initial chlorophenol concentration 100 mg/L; pH 6; Na₂SO₄ 5 g/L; current 6 mA; volume 60 ml.

rophanol. It is obvious that current has great effect on the removal rate of chlorophenol. The higher the current is, the faster the removal rate is. For a current of 2 mA (terminal voltage is 3 V), the removal rate is so slow that it is not more than 20% after 5 hrs treatment. For a current of 4 mA, 6 mA and 8 mA (5 V-9 V), the tendency of degradation is very similar. The treatment effect is 8 mA > 6 mA > 4 mA. Higher current requires higher voltage; however, higher voltage is unfavorable for the electrode life. Therefore, current is controlled in the appropriate range in this work.

Fig. 7 shows the degradation of chlorophenol on different electrodes. As shown, the cathode has better effect on the degradation of chlorophenol than the anode. The removal efficiency is 87% in 5 hrs on the cathode, while it is only 62% on the anode during the same time. This phenomenon occurs in the entire current range from 2 mA to 8 mA.

During the degradation of chlorophenol, phenol and organic acids were detected, in which phenol was the main product. Little bub-

bles were observed to be emitted from the surface of the electrode. Through the verification, they were hydrogen. The electrochemical mechanism of dechlorination of chlorophenol was tentatively proposed as the following:

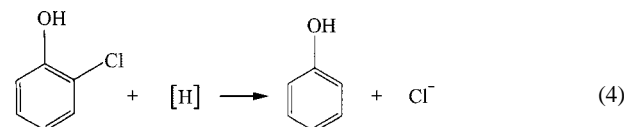
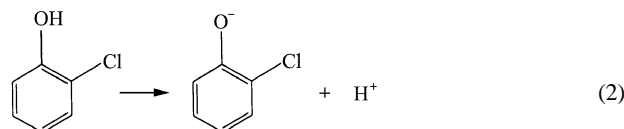

In general, two pathways that may be available to contribute the dechlorination are widely discussed [Lin and Tseng, 1999; Ross et al., 1997]. As shown in Fig. 8, the first pathway involves the chlorinated compound being adsorbed on the surface of metal and the reduction occurs by direct electron transfer from (Fig. 8A). The second pathway involves the formation of atomic hydrogen on the surface of the metal and this can mediate the reduction of the chlorinated compounds (Fig. 8B). Direct electron transfer mechanism is not suggested here because proton was reduced to hydrogen rapidly at the controlled potential and the little bubbles were found to be releasing from the surface of the electrode. In addition, adsorption of the organic substrate on the metal surface is the first step for the direct electron mechanism so that electrons can directly transfer. High pH (about 10) was measured in the region of the cathode, and low pH (about 3) was observed at the anode. Under the alkaline condition, the chlorophenol existed predominantly in the ionized form; thus the chlorophenol with negative charge was against the surface of cathode. In a word, indirect dechlorination by atomic hydrogen would be the degrading mechanism.

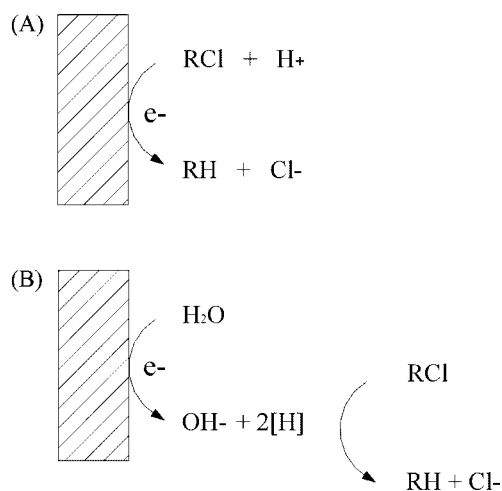

Fig. 8. The proposed pathways for the dechlorination.

(A) Direct electron transfer at the electrode surface; (B) Indirect dechlorination by the atomic hydrogen.

CONCLUSIONS

The removal rate of phenol is rapid at high current density and low initial phenol concentration. However, large amount of phenol removal was achieved at higher initial phenol concentration. The complete oxidation of phenol to carbon dioxide by electrochemical treatment would not be economical due to high-energy consumption, and it was preferable that phenol could be partially oxidized to organic acids of a biological nutrient, which required less energy consumption.

The photo-electrocatalysis process could accelerate the degradation of chlorophenol. A comparison with three kinds of oxidation processes proved that the combined process of electrocatalysis and photocatalysis has significant synergetic effects, and suitable applied voltage is 3 V.

Pair electrodes were very effective for removing the chlorophenol by the combination of reductive dechlorination and oxidation. The proposed mechanism would be indirect dechlorination by atomic hydrogen.

The electro-assisted advanced processes to degrade phenolic compounds in wastewater offer advantages over simple, high efficient, moderate reaction conditions, and relatively low energy-consumption. It is a feasible method in treating organic matter for water purification.

ACKNOWLEDGEMENTS

This work was financially supported by Foundation of Educational Ministry of China and Natural Science Foundation of Zhejiang Province (No 200043).

REFERENCES

- APHA, AWWA, WEF, "Standard Method for the Examination of Water and Wastewater (19th Ed);" Washington DC, 515 (1995).
- Chen, J., Rulkens, W. H. and Bruning, H., "Photochemical Elimination of Phenols and Cod in Industrial Wastewaters;" *Wat. Sci. Tech.*, **35**, 231 (1997).
- Choi, W., Kim, S., Cho, S., Yoo, H. I. and Kim, M. H., "Photocatalytic Reactivity and Diffusing OH Radicals in the Reaction Medium Containing TiO₂ Particles;" *Korean J. Chem. Eng.*, **18**, 898 (2001).
- Comminellis, C. and Nerini, A., "Anodic Oxidation of Phenol in the Presence of NaCl for Wastewater Treatment;" *J. Appl. Electrochem.*, **25**, 23 (1995).
- Grega, M. D. La, Buckingham, P. L. and Evans, L. C., "Hazardous Waste Management;" McGraw-Hill, New York (1994).
- Hirvonen, A., Trapido, M., Hentunen, J. and Tarhanen, J., "Formation of Hydroxylated and Dimeric Intermediates during Oxidation of Chlorinated Phenols in Aqueous Solution;" *Chemosphere*, **41**, 1211 (2000).
- Hugul, M., Boz, I. and Apak, R., "Photocatalytic Decomposition of 4-Chlorophenol over Oxide Catalysts;" *J. Hazardous Materials B*, **64**, 313 (1999).
- Juttner, K., Galla, U. and Schmieder, H., "Electrochemical Approaches to Environmental Problems in the Process Industry;" *Electrochim. Acta*, **45**, 2575 (2000).
- Lee, J. and Langer, S. H., "Mathematical Analysis and Experimental Results of Applying Enhanced-Surface-Area Packed-Bed Electrodes in Electrogenerative Sulfur Dioxide Oxidation;" *Korean J. Chem. Eng.*, **12**, 168 (1995).
- Lee, K. R., Lim, J. H., Lee, J. K. and Chun, H. S., "Reduction of Carbon Dioxide in 3-Dimensional Gas Diffusion Electrodes;" *Korean J. Chem. Eng.*, **16**, 829 (1999).
- Lin, C. H. and Tseng, S. K., "Electrochemically Reductive Dechlorination of Pentachlorophenol Using a High Overpotential Zinc Cathode;" *Chemosphere*, **39**, 2375 (1999).
- Lu, M. C. and Chen, J. N., "Pretreatment of Pesticide Wastewater by Photocatalytic Oxidation;" *Wat. Sci. Tech.*, **36**, 117 (1997).
- Park, D. R., Ahn, B. J., Park, H. S., Yamashita, H. and Anpo, M., "Photocatalytic Oxidation of Ethylene to CO₂ and H₂O on Ultrafine Powdered TiO₂ Photocatalysts: Effect of the Presence of O₂ and H₂O and the Addition of Pt;" *Korean J. Chem. Eng.*, **18**, 930 (2001).
- Rajeshwar, K., Ibanex, J. G. and Swain, G. M., "Electrochemistry and the Environment;" *J. Appl. Electrochem.*, **24**, 1077 (1994).
- Ross, N. C., Spackman, R. A., Hitchman, M. L. and White, P. C., "An Investigation of the Electrochemical Reduction of Pentachlorophenol with Analysis by HPLC;" *J. Appl. Electrochem.*, **27**, 51 (1997).
- Verschueren, K., "Handbook of Environmental Data on Organic Chemicals;" Van Nostrand Reinhold Co., New York (1977).
- Wu, Z. C. and Zhou, M. H., "Partial Degradation of Phenol by Advanced Electrochemical Oxidation Process;" *Environ. Sci. Technol.*, **35**, 2698 (2001).
- Zhou, M. H., Wu, Z. C., Zhu, J., Ye, Q. and Fu, J., "p-Nitrophenol Degradation by Homogeneous Photochemical Oxidation Combined with Electrocatalysis;" *Chinese J. of Catalysis*, **23**, in press (2002).