

Dynamic analysis of thermally coupled distillation sequences with unidirectional flows for the separation of ternary mixtures

Juan Gabriel Segovia-Hernández[†], Adrián Bonilla-Petriciolet* and Luis Ignacio Salcedo-Estrada**

Universidad de Guanajuato, Facultad de Química, Noria Alta s/n, Guanajuato, Gto., México

*Instituto Tecnológico de Aguascalientes, Departamento de Ingeniería Química, Av. López Mateos, Aguascalientes, Ags., México

**Universidad Michoacana de San Nicolás Hidalgo, Facultad de Ingeniería Química, Santiago Tapia 403, Morelia, Mich., México

(Received 17 October 2005 • accepted 14 March 2006)

Abstract—The Petlyuk distillation system has been considered with special interest because of the high energy savings it can provide with respect to the operation of sequences based on conventional columns. The original design of the Petlyuk structure, however, shows two interconnections that seem to affect its operational and controllability properties. To overcome this problem, two alternate structures have been suggested that use unidirectional flows of the vapor or liquid interconnecting streams. In this work, a comparative analysis of the control properties of the Petlyuk column and the alternate arrangements with unidirectional interconnecting flows is presented. Through a singular value decomposition analysis, it is shown that the alternate schemes provide better theoretical controllability properties than the Petlyuk system. Closed loop tests using proportional-integral controllers were also carried out, and the results showed that, in most of the cases considered, the alternate arrangements improved the dynamic responses of the Petlyuk column. Such arrangements, therefore, show promising perspectives for its practical consideration.

Key words: Thermally Coupled Distillation, Distillation Control, Petlyuk Column

INTRODUCTION

Distillation is one of the most important separation methods. It can even be said that perhaps it is the most widespread method in the industrial area, so we have a great deal of information about it. One of its most important and well-known properties is that a considerable amount of energy is needed to separate something into its compounds by distillation. For decades the main purpose of the researchers working in this area was to develop as easy and profitable arrangements for different separations as possible. Several strategies have been adopted to improve the energy performance of distillation systems. Non-conventional distillation sequences involve the use of thermal couplings in which heat transfer is accomplished by direct contact of material flows between the columns of the system. In the case of ternary mixtures, these thermally coupled arrangements include the side stripper (TCDS-SR; Fig. 1a), the side rectifier (TCDS-SS; Fig. 1b) and the fully thermally (Petlyuk scheme; Fig. 1c) coupled column, among others. In general, the studies for the analysis of the structures of Fig. 1 showed that expected savings of minimum internal vapor flows, and therefore of minimum energy requirements, of up to 30 percent could be obtained with respect to the operation of conventional direct and indirect distillation sequences [Tedder and Rudd, 1978; Cerda and Westerberg, 1981; Glinos and Malone, 1988; Fidkowski and Krolikowski, 1991; Finn, 1993; Annakou and Mizsey, 1996]. The savings depend on the amount of the intermediate component in the feed mixture, and are more noticeable for feeds with low or high contents of the intermediate component. More recent works [Hernández and Jiménez, 1996, 1999a; Grossmann et al., 1999; Yeomans and Grossmann,

2000; Kim, 2000; Amminudin et al., 2001; Muralikrishna et al., 2002; Kim et al., 2002] have reported the use of optimization strategies for TCDS to detect designs with minimum energy consumption under un-pinched (finite reflux) conditions. When the performance of the three integrated schemes has been compared, it has been found that in general the Petlyuk system offers better energy savings than the systems with side columns. The energy savings of TCDS sequence can be explained in terms of the internal composition profiles of the intermediate component [Triantafyllou and Smith, 1992; Hernández et al., 2003]. Despite the well-established potential of TCDS in terms of their energy savings, these structures had not been considered for industrial implementation until recent times [Kaibel and Schoenmakers, 2002; Kim et al., 2003], largely because of the lack of operational experience and to the expectations that they might be rather difficult to control [Dünnebiel and Pantelides, 1999]. To promote a stronger potential for its industrial implementation, a proper understanding of the operation and control properties of the TCDS schemes is needed to complement the energy savings results. Clearly, the expectation that the dynamic properties of TCDS columns may cause control difficulties, compared to the rather well-known behavior of the conventional direct and indirect sequences for the separation of ternary mixtures, has been one of the factors that has contributed to their lack of industrial implementation. Recent efforts have been reported towards the understanding of the dynamic properties of the TCDS columns [Wolff and Skogestad, 1995; Abdul-Mutalib and Smith, 1998; Serra et al., 1999, 2003; Hernández and Jiménez, 1999b; Jiménez et al., 2001; Segovia-Hernández et al., 2002a, b, 2004, 2005; Hernández et al., 2005; Cardenas et al., 2005], and in general they have shown that some of these integrated options are controllable, so that the predicted savings in energy would probably not be obtained at the expense of operational and control problems. Further development in this area is still needed. Another line

[†]To whom correspondence should be addressed.

E-mail: gsegovia@quijote.ugto.mx

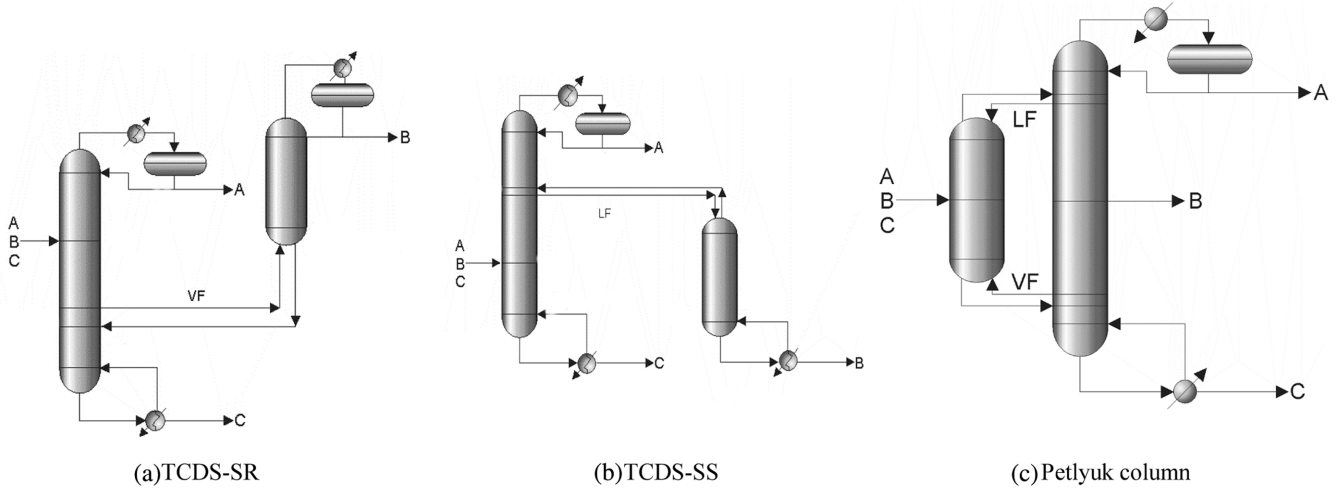

Fig. 1. Three thermally coupled distillation schemes for the separation of ternary mixtures.

of research has been observed in recent times, in which efforts to generate alternate structures to the systems of Fig. 1, but with more promising expectations as far as their control perspectives, have been suggested. For instance, Annakou et al. [1996], Agrawal and Fidkowski [1998, 1999], Rong and Kraslawski [2002, 2003] and Emtir et al. [2003] have reported some newer configurations for TCDS that appear to have some operational advantages over the expected dynamic properties of the designs of Fig. 1. In particular, the Petlyuk column is the most energy-efficient option, but its structure poses two interesting features. One, it has the highest number of interconnections, and two, the streams in the vapor phase (and therefore also in the liquid phase) flow in the two directions, back and forth between the columns. These aspects affect not only the design but also the control properties of the Petlyuk system. Alternative options can be developed through the correction of each of these two items. Thus, through a reduction on the number of interconnections, or through the use of unidirectional interconnecting flows, one can conceptually generate simpler schemes, in principle easier to control. Six alternative schemes to the Petlyuk column that arise from such modifications have been recently analyzed and reported to show similar energy savings as the original arrangement [Jiménez et al., 2003]. These results open a wide interest for the analysis of the dynamic properties of such new schemes. If the options with similar energy efficiencies are proved to provide better controllability properties than the Petlyuk system, then their potential for industrial implementation would be clearly enhanced. In this work a set of two modifications of the Petlyuk system that use unidirectional flows of both interconnecting streams are considered to analyze their control behavior. The explicit aim of the study is to show if such design modifications may lead to an improvement on the control properties of the original Petlyuk arrangement.

DESIGN AND MODEL OF THE PETLYUK COLUMN

A model was first developed for the Petlyuk system. Consider a generic equilibrium stage as shown in Fig. 2. The model for the distillation system is based on the following set of equations (with all symbols defined in the Nomenclature section).

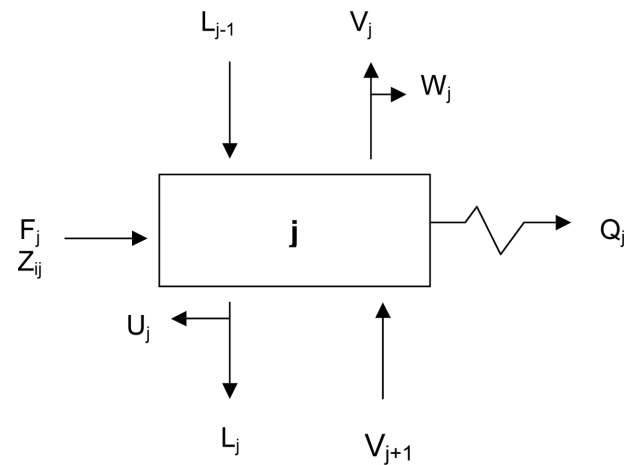

Fig. 2. A generic equilibrium stage for the model of the Petlyuk system.

Total mass balance:

$$\frac{dM_j}{dt} = L_{j-1} + V_{j+1} + F_j^L + F_j^V - (L_j + U_j) - (V_j + W_j) \quad (1)$$

Component mass balance:

$$\frac{d(M_j X_{ij})}{dt} = L_{j-1} X_{i,j-1} + V_{j+1} Y_{i,j+1} + F_j^L Z_{ij}^L + F_j^V Z_{ij}^V - (L_j + U_j) X_{ij} - (V_j + W_j) Y_{ij} \quad (2)$$

Energy balance:

$$\frac{d(M_j \bar{U}_{ij})}{dt} = L_{j-1} \bar{h}_{j-1} + V_{j+1} \bar{H}_{j+1} + F_j^L \bar{h}_j^L + F_j^V \bar{H}_j^V - (L_j + U_j) \bar{h}_j - (V_j + W_j) \bar{H}_j + Q_j \quad (3)$$

Equilibrium relationships:

$$Y_{ij} = K_{ij} X_{ij} \quad (4)$$

Summation constraints:

$$\sum_{i=1}^{NC} K_{ij} X_{ij} - 1.0 = 0 \quad (5)$$

Stage hydraulics (Francis weir formula):

$$L_j = k_f L_{wf} (h_{ow})_j^{3/2} \quad (6)$$

As written, this set of equations provides the dynamic model for the Petlyuk column. Since a design for the column must first be obtained, the same set of equations but written for steady state conditions provides the basis for such a design problem. In any case, the model shows a coupled structure because of the recycle streams between the two columns such that the full set of equations must be solved simultaneously.

The complete design of the Petlyuk system should provide the tray structure of each column, the tray positions for the interconnecting streams, and the operating conditions (such as pressure and reflux ratios or values of the interconnecting streams) that minimize a given objective function, for instance the total yearly cost. This case yields a complicated optimization problem, which would require a mixed-integer nonlinear programming formulation. To overcome such a situation, a sequential solution on the tray structure and oper-

ating conditions was implemented. For the tray structure, a base design is obtained from the information provided by a conventional distillation system (design methods for conventional distillation systems are well known) consisting of a prefractionator followed by two binary separation columns. Fig. 3 shows how the six tray sections of the conventional sequence are related to the structure of the Petlyuk system; such sections perform similar separation tasks in both arrangements. Therefore, the design of the conventional sequence, readily obtained through the use of shortcut methods, provides the tray distribution for the integrated system. The design depends on the operating pressure, which can be set such that the use of refrigerants in the condenser is avoided. Once the design (tray structure) is obtained, it needs to be validated. Steady state rigorous simulations are then conducted to test the preliminary design. If the design specifications (product compositions) are met with the tray structure obtained with the section analogy procedure, the preliminary design is successful; otherwise, proper arrangements in the tray structure are implemented until the specified product compositions

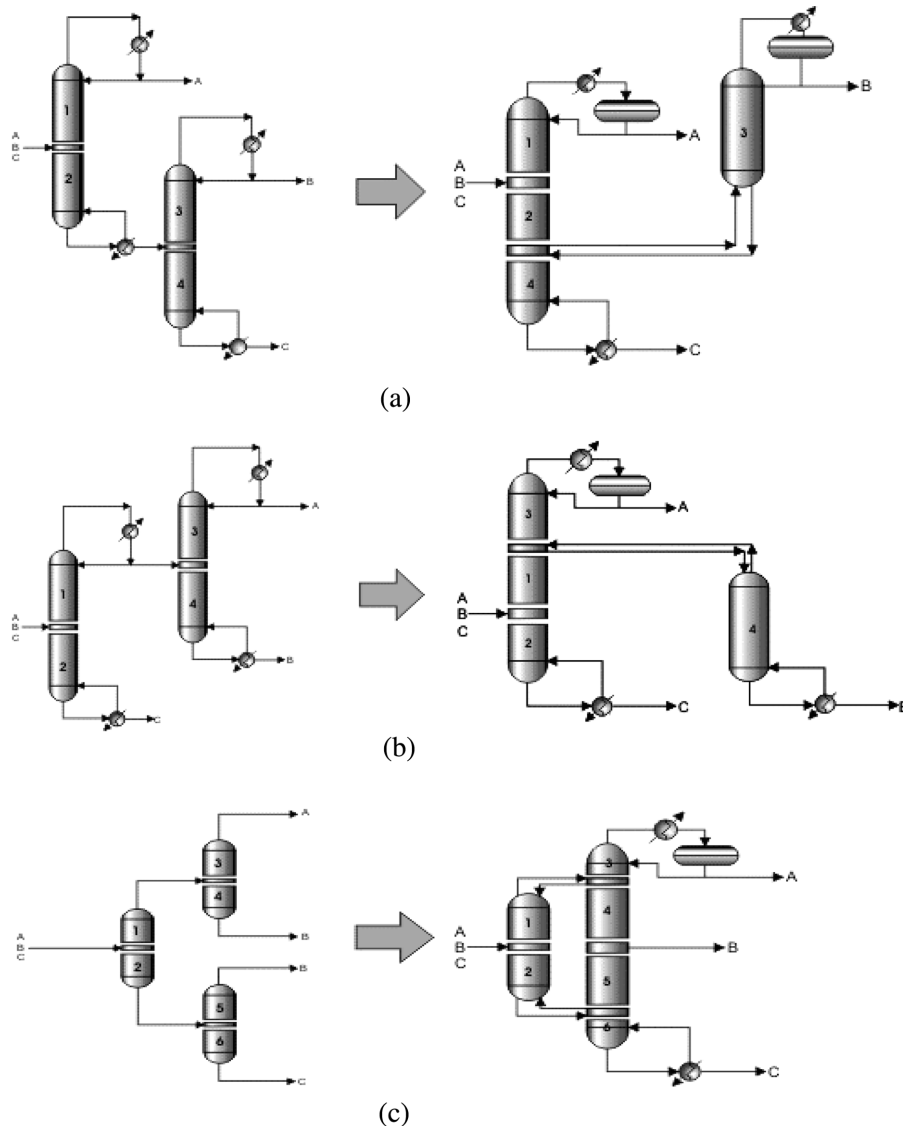

Fig. 3. Rearrangement of the conventional distillation sequences into thermally coupled distillation columns.

are obtained.

To complete the design, the validated structure of the Petlyuk system is finally subjected to an optimization procedure to obtain the operating conditions that minimize the energy consumption required for the separation task. Two degrees of freedom remain at this stage, which are used as search variables for the optimization process. The selected search variables are the interconnecting streams of the Petlyuk column (LF and VF, see Fig. 1c). Further details on this design procedure are available in Hernández and Jiménez [1999a].

MORE OPERABLE THERMALLY COUPLED DISTILLATION SEQUENCES

As mentioned earlier, the Petlyuk column (Fig. 1c) poses potential operational problems because of the two directions of the interconnecting vapor streams. The overhead interconnecting stream of the prefractionator, in the vapor phase, goes from a high pressure point of the prefractionator to a low pressure point of the main column, but the recycle vapor stream from the second column requires a higher pressure of the main column with respect to the prefractionator. This creates an operational conflict since the pressure of neither column can be set higher or lower than the other one. This problem could be avoided, in principle, by implementing unidirectional

flows in the interconnecting streams in an alternate arrangement. Agrawal and Fidkowski [1998, 1999] have proposed some of such modifications; two of them are taken in this work for their analysis. Fig. 4b shows a modified Petlyuk arrangement with unidirectional liquid interconnecting streams from the first column to the second one, while Fig. 4c shows the second option of a modified arrangement with unidirectional vapor interconnecting streams. In the remainder of this work, an analysis on the energy requirements and control properties of the unidirectional alternative schemes of Figs. 4b and 4c is conducted, with a comparison shown with respect to those required by the Petlyuk column.

The design of the alternative arrangements is carried out through a section analogy procedure with respect to the design of the Petlyuk system. The system shown in the Fig. 4b is built by moving tray section 3 from the Petlyuk column (Fig. 4a) along with the condenser to the top of the first column (with a liquid stream) and at the bottom of the first column (with another liquid stream). Both thermal couplings are preserved, but both liquid flows go from the first column to the second column. We identify this configuration as a fully coupled arrangement with liquid flows (PUL). Similarly, one can remove the bottom tray section of the Petlyuk column (section 6 of Fig. 4a) with the reboiler and imple-

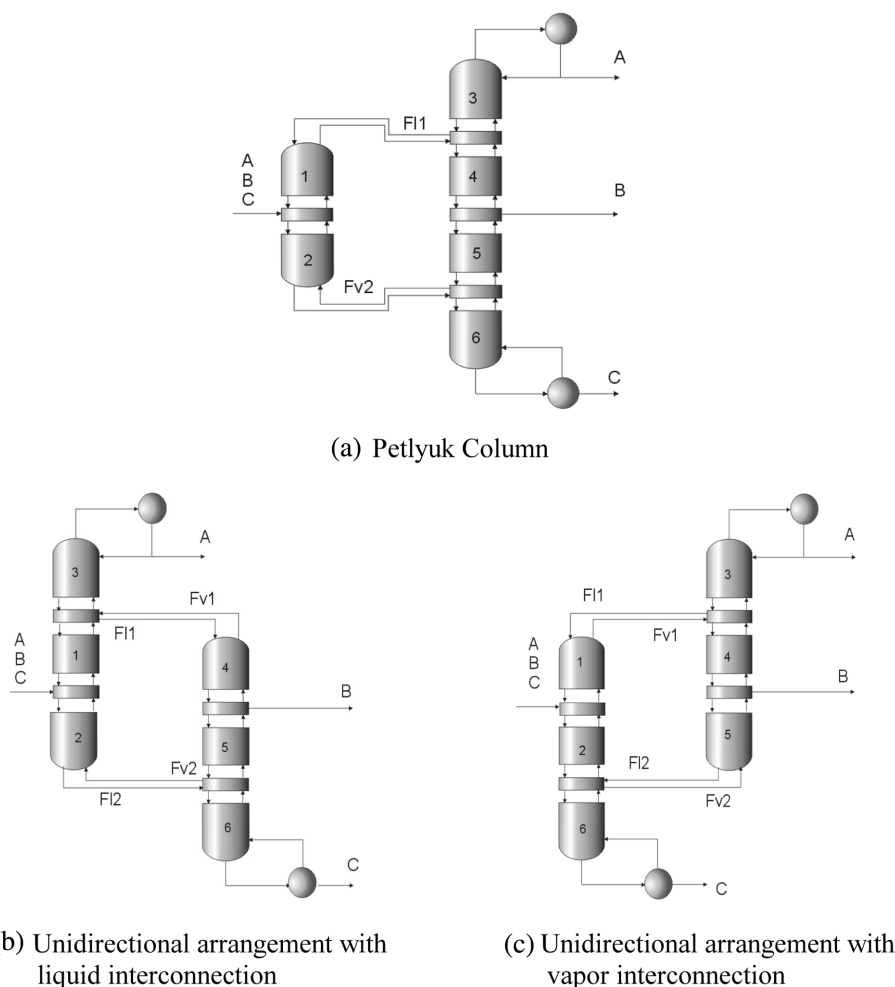

Fig. 4. Alternative schemes to the Petlyuk column.

ment them in the bottom part of the first column to produce a fully coupled arrangement with vapor streams (PUV, Fig. 4c). The resulting structures with unidirectional interconnecting flows also show two degrees of freedom each, which can be used to find out the operating conditions under which minimum energy consumptions are obtained.

ENERGY CONSUMPTION

To carry out the analysis, a case study of the separation of a ternary mixture of n-pentane (A), n-hexane (B) and n-heptane (C) with a feed composition low in the intermediate component (A, B, C equal to 0.4, 0.2, 0.4) was considered. The selected composition reflects typical values for which significant energy savings of TCDS have been reported. Design specifications included 98.7% purity in A, 98% purity in B and 98.6% purity in C. A feed flowrate to the sequence of 100 lb-mol/hr, available as a saturated liquid, was taken. To avoid the use of refrigerants that would have a high impact on the economics of the separation sequence, the design pressure for each column was chosen such that all condensers could be operated with cooling water. The thermodynamic properties of the mixture were estimated with the Chao-Seader correlation [Henley and Seader, 1981].

The first part of the analysis was conducted to detect the designs with minimum energy consumption for the integrated sequences. Once a validated design (tray structure) was obtained, an optimization procedure was carried out on the recycle streams for each of the three coupled sequences to detect the operating conditions under which each design was more energy efficient.

Table 1 shows the values of the minimum energy consumption obtained for the two systems with unidirectional flows and compares them to the one obtained for the Petlyuk system. It can be noted that similar energy requirements are obtained for the three options. The energy consumption of the structure with interconnecting vapor streams was slightly higher, but probably because of numerical convergence aspects. The results are consistent with those presented by Jiménez et al. [2003], who conducted a more exhaustive study on the energy consumption of these types of sequences and reported that the new structures have similar energy consumption levels as the Petlyuk scheme. The new sequences are therefore suitable candidates for a complementary analysis on their dynamic properties.

CONTROL BEHAVIOR

The controllability analysis was conducted in two parts. The theoretical control properties of the three schemes were first predicted through the use of the singular value decomposition (SVD) technique, and then closed-loop dynamic simulations were conducted to analyze the control behavior of each system and to compare those results with the theoretical predictions provided by SVD.

1. Singular Value Decomposition

Table 1. Minimum energy requirements (Btu/h) for each arrangement

	Petlyuk column	PUL	PUV
	1,772,479	1,777,537	1,834,960

The application of the SVD technique provides a measure of the controllability properties of a given dynamic system. More than a quantitative measure, SVD should provide a suitable basis for the comparison of the theoretical control properties among the thermally coupled sequences under consideration. To prepare the information needed for such a test, each of the product streams of each of the thermally coupled systems was disturbed with a step change in product composition and the corresponding dynamic responses were obtained. A transfer function matrix relating the product compositions to the intended manipulated variables was then constructed for each case. The transfer function matrix can be subjected to SVD:

$$G = V \Sigma W^H \quad (7)$$

where $\Sigma = \text{diag}(\sigma_1, \dots, \sigma_n)$, σ_i = singular value of $G = \lambda_i^{1/2}(GG^H)$; $V = (V_1, V_2, \dots)$ matrix of left singular vectors, and $W = (w_1, w_2, \dots)$ matrix of right singular vectors. Two parameters of interest are the minimum singular value, σ_n , and the ratio of maximum to minimum singular values, or condition number:

$$\gamma^* = \sigma^* / \sigma_n \quad (8)$$

The minimum singular value is a measure of the invertibility of the system and therefore represents a measure of the potential problems of the system under feedback control. The condition number reflects the sensitivity of the system under uncertainties in process parameters and modeling errors. These parameters provide a qualitative assessment of the dynamic properties of a given design. The objective is to identify the systems with higher minimum singular values and lower condition numbers; those systems are expected to show the best dynamic performance under feedback control. A nice feature of the SVD test is that it is independent of the type of controller to be implemented; the basic idea is that the controllability properties of the system are instead limited or imposed by its inner dynamic structure.

The full application of the SVD method should consider a range of frequencies sufficiently high to give a complete coverage on the behavior of minimum singular values and conditions numbers, as shown by Hernández and Jiménez [1999b] and by Jiménez et al. [2001] for their controllability analysis of some conventional and non-conventional distillation systems. As a preliminary attempt, however, the SVD analysis was conducted in this work only at zero frequency. Such analysis requires only the steady-state gain matrix, and gives the theoretical controllability properties of each system around its nominal operating point, in this case around the point for which a minimum energy consumption was obtained. This information should be sufficient at this point for the intended comparative analysis on the controllability properties of the three thermally coupled systems.

Table 2 shows the results obtained from the application of the SVD at zero frequency for each sequence. The PUL column has

Table 2. Minimum singular value and condition number for each arrangement

Sequence	σ_n	γ^*
Petlyuk column	0.0055	1,260.47
PUL	0.4383	14.33
PUV	0.0363	252.68

the lowest value of the condition number, which implies that this sequence is better conditioned to the effect of disturbances than the other two integrated systems; it also presents the highest value of σ_s , which means that the sequence is expected to show the lowest control effort. Therefore, from this initial analysis, it is apparent that the PUL scheme will show the best operational properties of the three options under consideration. On the other hand, it is interesting to notice that the Petlyuk column offers the worst theoretical control properties (lowest minimum singular value and highest condition number), which supports the notion that the new arrangements may indeed improve the control properties of the Petlyuk system through the correction of the bidirectionality of the vapor interconnecting streams observed in the original design.

2. Closed-loop Simulations

To supplement the SVA analysis, rigorous dynamic simulations under closed loop operation were carried out. For the closed-loop analysis, several issues must be defined first, such as the control loops for each system, the type of process controller to be used, and the values of the controller parameters. Several techniques, such as the relative gain array method, can be used to fix the loops for a control system. In the case of distillation columns, however, such loops are fairly well established and used successfully in practice, at least for conventional columns. A well-known structure is based on energy balance considerations, which yields to so-called LV control structure in which the reflux flowrate L and the vapor boilup rate V (affected directly by the heat duty supplied to the reboiler) are used to control the distillate and bottom outputs compositions (see for instance Häggblom and Waller, 1992). The control loops for the integrated systems were chosen from extensions of the practical considerations observed for conventional distillation columns. The control objective was to preserve the output streams at their design purity specifications. Two control loops arise naturally from the experience on the operation of conventional columns. For the control of product stream A, which is obtained as an overhead product, the reflux flowrate was used, whereas for the control of product stream C, which is obtained as a bottom product, the reboiler heat duty was chosen. Product stream B is obtained as a side stream for the integrated arrangements, and in the lack of operational experience, its control was simply set through the manipulation of the side stream flow rate. It should be mentioned that such control loops have been used with satisfactory results in previous studies we have conducted on thermally coupled systems [Jiménez et al., 2001; Segovia-Hernández et al., 2002a, b, 2004]. The choice of the type of controller was based on the ample use that the Proportional-Integral (PI) mode has

Table 3. Parameters of the PI controllers for each control loop

Sequence	τ_i	κ_c
Petlyuk column	A=30	A=20
	B=5	B=130
	C=10	C=20
PUL	A=60	A=80
	B=150	B=140
	C=10	C=100
PUV	A=70	A=20
	B=5	B=40
	C=30	C=180

for distillation systems in industrial practice. Also, since this is the first reported analysis on the controllability properties of the alternative schemes of Figs. 4b and 4c, the choice may also provide a basis upon which the use of more elaborated control laws can be compared. As for the selection of the parameters of the PI controllers, care was taken to provide a common method for each of the sequences under comparison. A tuning procedure that involved the minimization of the integral of the absolute value (IAE) for each loop of each scheme was used [Stephanopoulos, 1984]. Therefore, for each loop, an initial value of the proportional gain was set; a search over the values of the integral reset time was conducted until a local optimum value of the IAE was obtained. The process was repeated for other values of the proportional gain. The selected set of controller parameters was then the one that provided a global

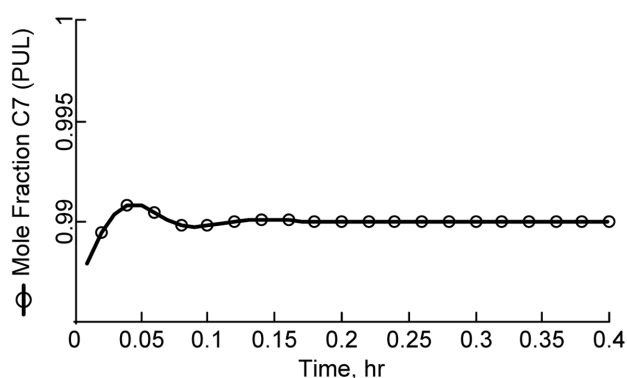

(a) PUL Column

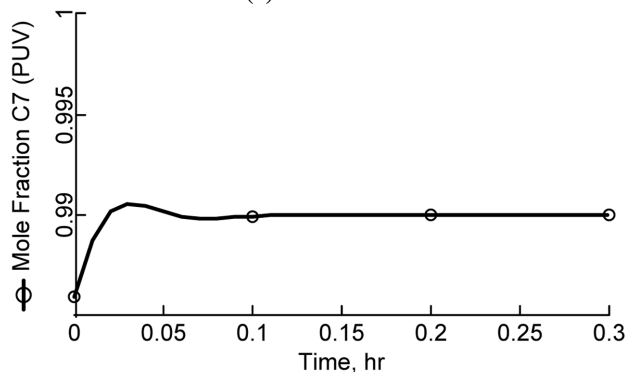

(b) PUV Column

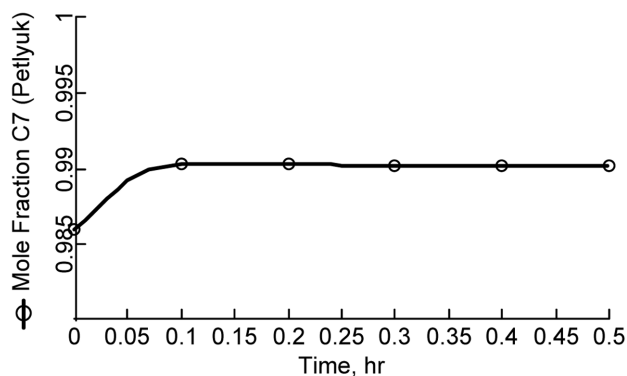

(c) Petlyuk Column

Fig. 5. Closed loop responses for a set point change in the composition of the heavy component.

minimum value of the IAE. Although the tuning procedure is fairly elaborate, the control analysis is conducted based on a common tuning method for the controller parameters; Table 3 shows the parameters obtained for the control of each product stream.

The simulations involve the solution of a rigorous tray-by-tray model of each sequence, given by Eqs. (1) to (6), together with the standard equations for the PI controllers for each control loop (with the parameters obtained through the minimization of the IAE criterion). The objective of the simulations is to find out how the dynamic behaviors of the systems compare under feedback control mode. To carry out the closed-loop analysis, two types of cases were considered: i) servo control, in which a step change was induced in the set point for each product composition under SISO feedback con-

trol, and ii) regulatory control, in which a feed disturbance with a 5% change in the composition of one component (with a proportional adjustment in the composition of the other components to keep the same total feed flowrate) was implemented.

2-1. Dynamic Behavior of the Heavy Component (Set Point Change)

When a set point change from 0.986 to 0.99 for the heavy component (C) was considered, the responses shown in Fig. 5 were obtained. The three options show good dynamic responses, with relatively low values of settling times, lower than 0.1 hours. The systems with unidirectional flows show some overshooting, while the Petlyuk system offers a more sluggish response.

In addition to the visual observations of the dynamic responses, a quantitative measure is needed to provide a better comparison. With such an objective, IAE values were evaluated for each closed-loop response. The PUL option shows the lowest IAE value of 5.607×10^{-5} , while the value for the Petlyuk column turns out to be 2.35×10^{-4} . Therefore, the results of the test indicate that, for the SISO control of the heaviest component of the ternary mixture, the PUL option provides the best dynamic behavior and improves the performance of the Petlyuk column. Such result is consistent with the prediction provided by the SVD analysis.

2-2. Dynamic Behavior of the Light Component (Set Point Change)

The results of the dynamic test for a positive change in the set point of the light component (A) are displayed in Fig. 6. For a change in the set point from 0.987 to 0.991, the three systems are shown to be controllable and reach a new value of product composition, although the PUL scheme shows a quicker adjustment. IAE values were also calculated for each response; the two best IAE values correspond to the new arrangements: 4.20×10^{-5} for the PUL system, and 6.10×10^{-5} for the PUV system. The IAE value for the Petlyuk column was 2.35×10^{-4} , which again shows a case in which the dynamic properties of the Petlyuk system are improved through the modifications that provide unidirectional flows of the interconnecting streams.

2-3. Dynamic Behavior of the Intermediate Component (Set Point Change)

Fig. 7 shows the dynamic responses obtained when the set point for the intermediate component was changed from 0.98 to 0.984. One may notice the better response provided by the Petlyuk column in this case, which is faster than the other two systems and without oscillations. When the IAE values were calculated, a remarkable difference in favor of the Petlyuk system was observed: 2.87×10^{-4} for the Petlyuk column, compared to 0.0011 for the PUL system and 0.0017 for the PUV system. The results from this test may seem unexpected, since the new arrangements have been proposed to improve the operation capabilities of the Petlyuk column. The SISO control of the intermediate component, interestingly, seems to conflict with that of the other two components in terms of the preferred choice from dynamic considerations.

2-4. Feed Disturbance Analysis

The last set of tests conducted in this work had to do with the implementation of feed disturbances. The regulatory control tests consisted of a change in the feed composition with the same nominal feed flowrate. Under such a scenario, it is clear that the feed composition of all components must change, but the component with the highest change (of 5 percent) was used to identify the tests. Fig. 8 shows the results obtained when a feed disturbance in the com-

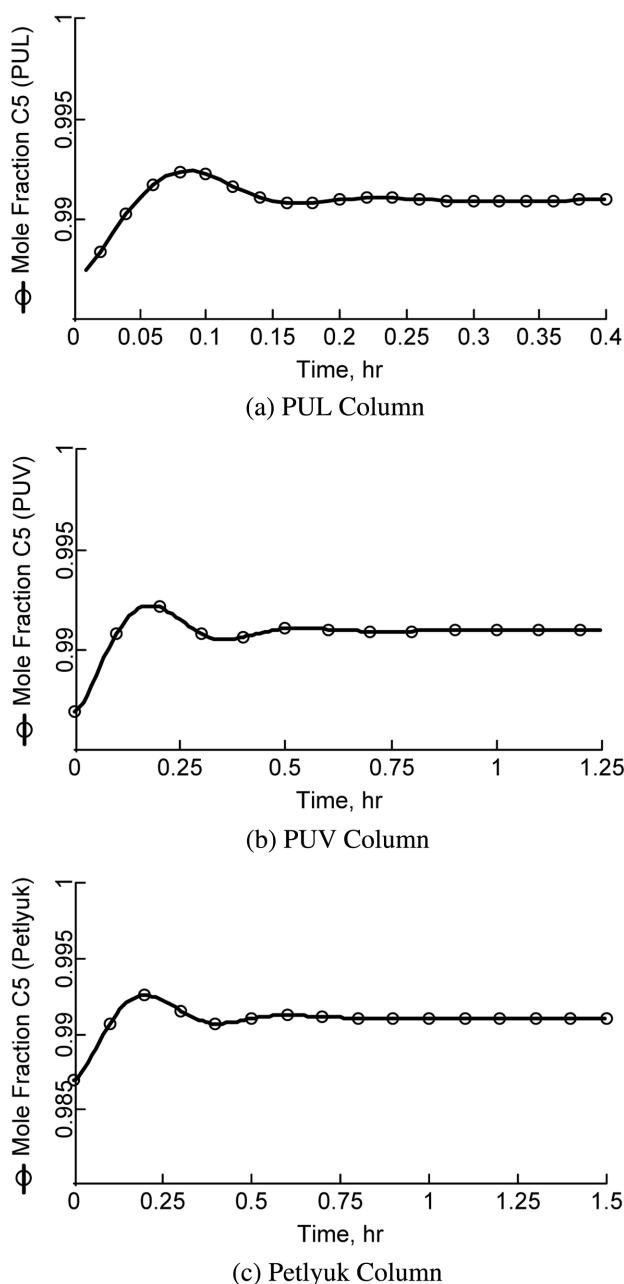

Fig. 6. Closed loop responses for a set point change in the composition of the light component.

position of component A was implemented. The PI controllers successfully rejected the feed disturbance for each of the separation systems, although the settling times are higher than those obtained for the servo tests. It can be observed that, consistent with the SVD results, the best response of the three alternatives is provided by the PUL system, which also implies a lower control effort. When the systems were compared according to their IAE values, the Petlyuk column showed the highest value of 0.0018.

The results for this test and for the responses to disturbances in feed compositions of B and C are summarized in Table 4. A consistent trend with the servo tests was observed, in the sense that one option provides the best common choice for the control of the system under feed disturbances on the extreme components of the mix-

ture, but a different arrangement yields superior dynamic performance for the control task under a feed disturbance on the intermediate component. From Table 4, the IAE values indicate that the

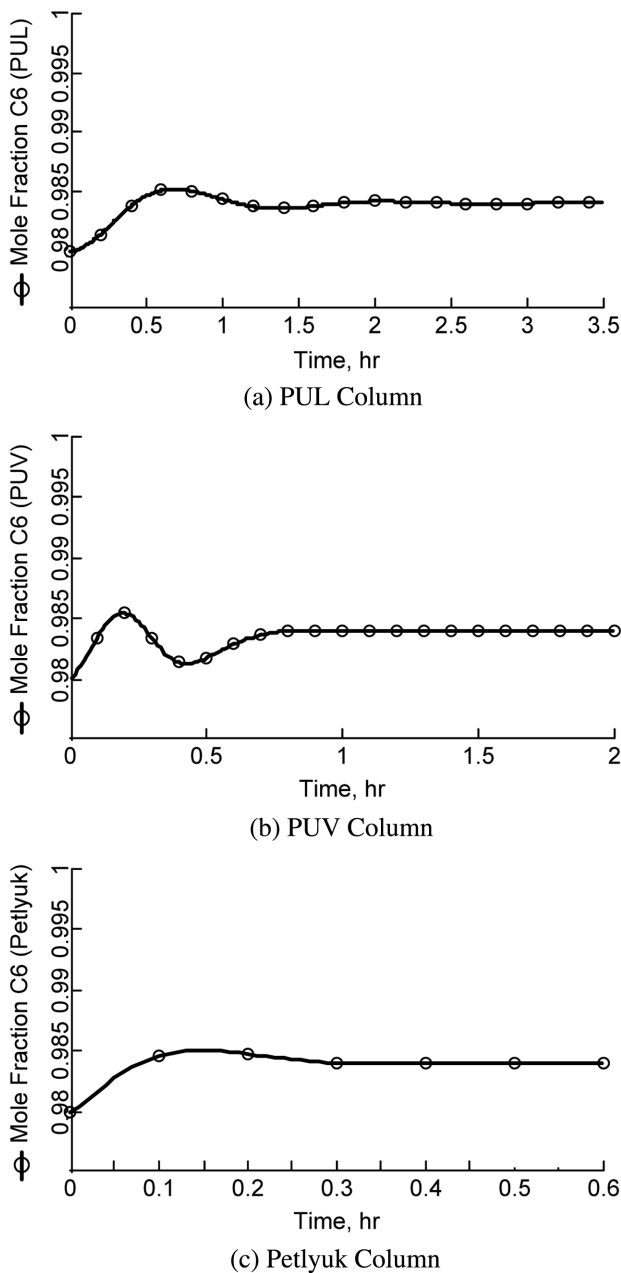

Fig. 7. Closed loop responses for a set point change in the composition of the intermediate component.

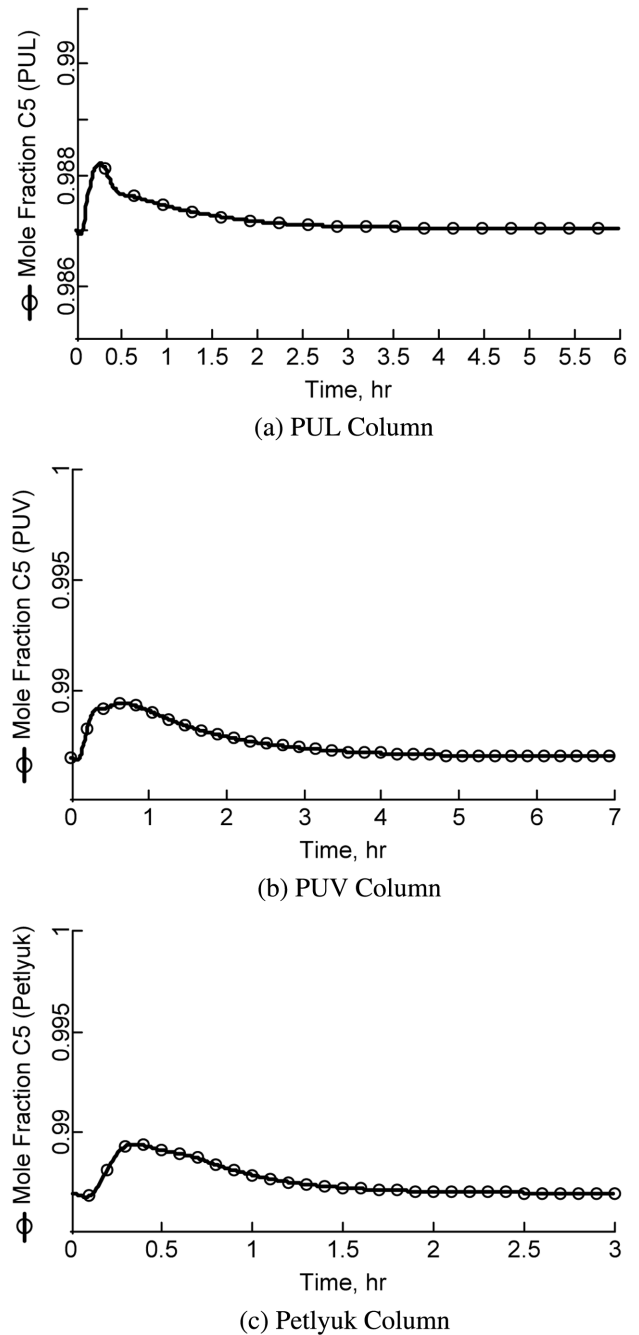

Fig. 8. Closed loop responses for feed disturbance in the composition of the light component.

Table 4. IAE values for the feed disturbance tests

Sequence	A	B	C
Petlyuk	0.0018	1.66×10^{-4}	5.83×10^{-4}
PUL	3.63×10^{-4}	0.0059	9.60×10^{-5}
PUV	0.0011	1.50×10^{-4}	6.20×10^{-4}

PUL system shows the best behavior for feed disturbances in the light and heavy component. However, the PUL arrangement shows the worst response when the feed disturbance in the intermediate component was considered, in which case both the Petlyuk and the PUV systems show fairly similar rejection capabilities.

CONCLUSIONS

An analysis on the dynamic properties of the two alternate schemes with unidirectional flows of the interconnecting streams has been conducted in this work and compared to the behavior of the original Petlyuk arrangement. A simplified analysis via singular value decomposition at zero frequency indicates that alternate arrangements may improve the controllability properties around the nominal operating point with respect to the Petlyuk system. The closed loop simulations were based on an SISO control strategy, and the results showed an interesting trend. The control behavior of the Petlyuk column was improved by the new options when the control tasks called for the control of the extreme components (A or C) of the ternary mixture. However, when the control of the intermediate component was considered, the Petlyuk column provided a better dynamic performance. Overall, the results here obtained show that the arrangements with unidirectional interconnections provide interesting choices for further consideration. For one thing, they seem to preserve the energy efficiency of the original Petlyuk system; for another, they were shown to offer proper controllability properties. In particular, the structure with unidirectional liquid interconnections provided the best theoretical control properties and yielded the best overall dynamic behavior under the operation scenarios considered in this work.

NOMENCLATURE

F	: feed flowrate
\bar{H}	: enthalpy of vapor
\bar{h}	: enthalpy of liquid
h_{ow}	: liquid height on weir
K	: equilibrium constant
L	: liquid flowrate
L_w	: weir length
M	: moles of liquid retained
Q	: heat added or extracted
t	: time
U	: liquid side stream
\bar{U}	: internal energy of liquid retained
u	: manipulated input
V	: vapor flowrate
W	: vapor side stream
X	: mol fraction in liquid phase
Y	: mol fraction in vapor phase

Superscripts

L	: liquid
V	: vapor

Subscripts

i	: component
j	: stage

ACKNOWLEDGMENTS

The authors acknowledge financial support received from PROMEP, México.

REFERENCES

- Abdul Mutalib, M. I. and Smith, R., "Operation and control of dividing wall distillation columns. Part I: Degrees of freedom and dynamic simulation," *Trans IChemE*, **76**, Part A, 308 (1998).
- Agrawal, R. and Fidkowski, Z., "More operable arrangements of fully thermally coupled distillation columns," *AIChE J.*, **44**(11), 2565 (1998).
- Agrawal, R. and Fidkowski, Z., "New thermally coupled schemes for ternary distillation," *AIChE J.*, **45**(3), 485 (1999).
- Amminudin, K. A., Smith, R., Thong, D. Y.-C. and Towler, G. P., "Design and optimization of fully thermally coupled distillation columns. Part I: Preliminary design and optimization methodology," *Trans IChemE*, **79**, Part A, 701 (2001).
- Annakou, O. and Mizsey, P., "Rigorous investigation of heat pump assisted distillation," *Heat Recovery Syst. CHP*, **15**(3), 241 (1995).
- Annakou, O. and Mizsey, P., "Rigorous comparative study of energy-integrated distillation schemes," *Ind. Eng. Chem. Res.*, **35**, 1877 (1996).
- Annakou, O., Meszaros, A., Fonyo, Z. and Mizsey, P., "Operability investigation of energy integrated distillation schemes," *Hung. J. Ind. Chem.*, **24**, 155 (1996).
- Cardenas, J. C., Hernández, S., Gudiño-Mares, I. R., Esparza-Hernández, F., Irianda-Araujo, C. Y. and Domínguez-Lira, L. M., "Analysis of control properties of thermally coupled distillation sequences for four-component mixtures," *Ind. Eng. Chem. Res.*, **44**, 391 (1996).
- Cerda, J. and Westerberg, A. W., "Shortcut methods for complex distillation columns. I. Minimum reflux," *Ind. Eng. Chem. Process Des. Dev.*, **20**, 546 (1981).
- Dünnebier, G. and Pantelides, C., "Optimal design of thermally coupled distillation columns," *Ind. Eng. Chem. Res.*, **38**, 162 (1999).
- Emtir, M., Mizsey, P., Rev, E. and Fonyo, Z., "Economic and controllability investigation and comparison of energy-integrated distillation schemes," *Chem. Biochem. Eng. Q.*, **17**(1), 31 (2003).
- Fidkowski, Z. and Krolkowski, L., "Energy requirements of nonconventional distillation systems," *AIChE J.*, **36**(8), 1275 (1991).
- Finn, A., "Consider thermally coupled distillation," *Chem. Eng. Prog.*, **10**, 41 (1993).
- Glinos, K. and Malone, M. F., "Optimality regions for complex column alternatives in distillation systems," *Chem. Eng. Res. Des.*, **66**, 229 (1988).
- Grossmann, I. E., Caballero, J. A. and Yeomans, H., "Advances in mathematical programming for automated design, integration and operation of chemical processes," *Korean J. Chem. Eng.*, **16**, 407 (1999).
- Hägglblom, K. E. and Waller, K. V., *Control structures, consistency, and transformations, in practical distillation control*, Edited by W. L. Luyben, Van Nostrand Reinhold, NY (1992).
- Henley, E. J. and Seader, J. D., *Equilibrium-stage separation operations in chemical engineering*, Wiley, New York (1981).
- Hernández, S. and Jiménez, A., "Design of optimal thermally-coupled distillation systems using a dynamic model," *Trans IChemE*, **74**, Part A, 357 (1996).

- Hernández, S. and Jiménez, A., "Design of energy-efficient petlyuk systems," *Comput. Chem. Eng.*, **23**(8), 1005 (1999a).
- Hernández, S. and Jiménez, A., "Controllability analysis of thermally coupled distillation systems," *Ind. Eng. Chem. Res.*, **38**(10), 3957 (1999b).
- Hernández, S., Pereira-Pech, S., Jiménez, A. and Rico-Ramírez, V., "Energy efficiency of an indirect thermally coupled distillation sequence," *Can. J. Chem. Eng.*, **81**(5), 1087 (2003).
- Hernández, S., Gudiño-Mares, I. R., Cárdenas, J. C., Segovia-Hernández, J. G and Rico-Ramírez, V., "A short note on control structures for thermally coupled distillation sequences for four-component mixtures," *Ind. Eng. Chem. Res.*, **44**, 5857 (2005).
- Jiménez, A., Hernández, S., Montoy, F. A. and Zavala-García, M., "Analysis of control properties of conventional and nonconventional distillation sequences," *Ind. Eng. Chem. Res.*, **40**(17), 3757 (2001).
- Jiménez, A., Ramírez, N., Castro, A. and Hernández, S., "Design and energy performance of alternative schemes to the petlyuk distillation system," *Trans IChemE*, **81**, Part A, 518 (2003).
- Kaibel, G and Schoenmakers, H., *Process Synthesis and Design in Industrial Practice. European Symposium on Computer Aided Process Engineering-12*, (J. Grievink y J. V. Schijndel, Eds.), Elsevier, Holland, 9 (2002).
- Kim, Y. H., "Design of fully thermally coupled distillation column based on dynamic simulations," *Korean J. Chem. Eng.*, **17**, 570 (2000).
- Kim, Y. H., Nakaiwa, M. and Hwang, K. S., "Approximate design of fully thermally coupled distillation column," *Korean J. Chem. Eng.*, **19**, 383 (2002).
- Kim, Y. H., Choi, D. and Hwang, K. S., "Industrial application of an extended fully thermally coupled distillation column to BTX separation in naphtha reforming plant," *Korean J. Chem. Eng.*, **20**, 755 (2003).
- Meszaros, I. and Fonyo, Z., "A new bounding strategy for synthesizing distillation schemes with energy integration," *Comput. Chem. Eng.*, **10**, 545 (1990).
- Mizsey, P. and Fonyo, Z., "Energy integrated distillation system design enhanced by heat pumping distillation and absorption," *Inst. Chem. Eng.*, B69 (1992).
- Muralikrishna, K., Madhavan, K. P. and Shah, S. S., "Development of dividing wall distillation column design space for a specified separation," *Trans IChemE*, **80**, Part A, 155 (2002).
- Rong, B. G and Kraslawski, A., "Optimal design of distillation flowsheets with a lower number of thermal couplings for multicomponent separations," *Ind. Eng. Chem. Res.*, **41**, 5716 (2002).
- Rong, B. G and Kraslawski, A., "Partially thermally coupled distillation systems for multicomponent separations," *AIChE J.*, **49**, 1340 (2003).
- Segovia-Hernández, J. G., Hernández, S. and Jiménez, A., "Control behaviour of thermally coupled distillation sequences," *Trans IChemE*, **80**, Part A, 783 (2002a).
- Segovia-Hernández, J. G., Hernández, S. and Jiménez, A., "Análisis dinámico de secuencias de destilación térmicamente acopladas," *Información Tecnológica*, **13**, 103 (2002b).
- Segovia-Hernández, J. G., Hernández, S., Rico-Ramírez, V. and Jiménez, A., "A comparison of the feedback control behavior between thermally coupled and conventional distillation schemes," *Comput. Chem. Eng.*, **28**, 811 (2004).
- Segovia-Hernández, J. G., Hernández, S., Jiménez, A. and Femat, R., "Dynamic behavior and control of the petlyuk scheme via a proportional-integral controller with disturbance estimation," *Chem. Biochem. Eng. Q. J.*, **19**(3), 243 (2005).
- Serra, M., Espuña, A. and Puigjaner, L., "Control and optimization of the divided wall column," *Chem. Eng. Process.*, **38**, 549 (1999).
- Serra, M., Espuña, A. and Puigjaner, L., "Controllability of different multicomponent distillation arrangements," *Ind. Eng. Chem. Res.*, **42**, 1773 (2003).
- Stephanopoulos, G., *Chemical process control: An introduction to theory and practice*, Prentice Hall, Englewood Cliffs, NJ (1984).
- Tedder, D. W. and Rudd, D. F., "Parametric studies in industrial distillation: Part I. Design comparisons," *AIChE J.*, **24**, 303 (1978).
- Triantafyllou, C. and Smith, R., "The design and optimization of fully thermally coupled distillation columns," *Trans Inst. Chem. Eng.*, **70**, Part A, 118 (1992).
- Wolff, E. and Skogestad, S., "Operation of integrated three-products (petlyuk) distillation columns," *Ind. Eng. Chem. Res.*, **34**(6), 2094 (1995).
- Yeomans, H. and Grossmann, I., "Optimal design of complex distillation columns using rigorous tray-by-tray disjunctive programming models," *Ind. Eng. Chem. Res.*, **39**(11), 4326 (2000).