

## Nobel Lecture in Physiology or Medicine—1988<sup>1</sup>

### THE PURINE PATH TO CHEMOTHERAPY

GERTRUDE B. ELION

*Wellcome Research Laboratories, Burroughs Wellcome Co., 3030 Cornwallis Road  
Research Triangle Park, North Carolina 27709*

When I joined the Wellcome Research Laboratories in 1944, World War II was in progress. Since the work I am about to discuss covers a period of some 40 years, it may be pertinent to consider the "state of the art" at that time. Our ultraviolet absorption spectra were measured with a Bausch and Lomb spectrograph which had a carbon arc as the light source and photographic plates for recording the amount of light absorbed at each wavelength. There was no paper or ion-exchange chromatography, and purines were isolated and separated as copper and silver salts, or picrates, by fractional crystallization. Tritium and <sup>32</sup>P were available, but no <sup>14</sup>C or <sup>35</sup>S. Geiger counters were used for counting radioactivity; scintillation counters came much later. Some heavy isotopes, e.g., <sup>15</sup>N and <sup>13</sup>C were obtainable but required the use of a mass spectrometer, which few laboratories had. The state of knowledge of nucleic acids was rather rudimentary. We knew they contained purines and pyrimidines but the sequences were not known. The prevailing theory was that there were two purines and two pyrimidines in each tetranucleotide and that these tetranucleotides were strung together in some fashion. However, the nature of the internucleotide linkage had not been established and the helical structure of DNA had not yet been proposed.

In 1940 Woods and Fildes (1,2) had put forth the antimetabolite theory to explain the action of sulfonamides on bacteria, suggesting that the sulfonamides interfered with the utilization of a necessary nutrient, para-aminobenzoic acid. Hitchings theorized that, since all cells required nucleic acids, it might be possible to stop the growth of rapidly dividing cells (e.g., bacteria, tumors, protozoa) with antagonists of the nucleic acid bases. One might hope to take advantage of the faster rate of multiplication of these cells compared with normal mammalian cells and eventually sort out the biochemical differences between various types of cells by the way they responded to these antimetabolites (3,4). It was my assignment to work on purines, pteridines, and some other condensed pyrimidine systems.

It was, of course, necessary to have some biological systems to determine the potential activities of the new compounds. Essentially nothing was known at that time about the anabolic pathways leading to the utilization of purines for nucleic acid synthesis. A number of catabolic

enzymes were known: nucleases, nucleotidases, nucleosidases, deaminases (for guanine, adenine, adenosine and adenylic acid), xanthine oxidase and uricase. In 1947 Kalekar described the reversibility of nucleoside phosphorylase (5). The enzymes guanase and xanthine oxidase were useful in our laboratory to examine the purines as substrates or inhibitors of these enzymes (6,7). However, it was the microorganism *Lactobacillus casei* upon which we mainly relied. It could grow on adenine, guanine, hypoxanthine or xanthine, provided the pyrimidine thymine was added. It could also synthesize purines and thymine, if given a source of folic acid in the form of liver powder. [The structure of folic acid was not elucidated until 1946 by the Lederle group (8)]. Hitchings and Falco had devised a screening test in which it was possible to determine whether a compound could substitute for thymine (9) or a natural purine (4,10) or inhibit its utilization, and could also determine whether a compound was a folic acid antagonist (11,12).

Few chemists were interested in the synthesis of purines in those days and I relied mainly on methods in the old German literature. The transformation reactions were carried out mainly by the methods of Emil Fisher and the syntheses from pyrimidine intermediates by the methods of Traube. The direct replacement of oxygen by sulfur by the method of Carrington (13) also proved to be exceedingly useful for synthesizing the mercaptopurines (14,15).

In 1948 we found that 2,6-diaminopurine inhibited the growth of *L. casei* very strongly and that the inhibition was reversed specifically by adenine, but not by the other natural purines (4,16). However, low concentrations of diaminopurine could also be reversed by folic acid, an attribute which diaminopurine had in common with other diaminopyrimidines and diaminopyrimidine condensed systems (10). Studies on a diaminopurine-resistant strain of *L. casei* revealed that it grew poorly on adenine as a source of purine. We deduced that adenine and 2,6-diaminopurine must be anabolized by the same enzyme, and that the product of diaminopurine anabolism interfered with purine interconversion (17). That enzyme was reported by Kornberg in 1955 to be adenylate pyrophosphorylase (adenine phosphoribosyltransferase) (18). When tested on mouse tumors and the AKR mouse leukemia (19) or tumor cells in tissue culture (20) diaminopurine proved to be strongly inhibitory. It

<sup>1</sup> The Nobel Foundation 1989.

produced two good clinical remissions in chronic granulocytic leukemia in adults but produced severe nausea and vomiting, as well as severe bone marrow depression in two other patients (21). Interestingly, diaminopurine showed activity against vaccinia virus, a DNA virus, *in vitro* (22), but its toxicity in animals led us to abandon that possible utility.

#### ANTILEUKEMIC DRUGS

By 1951 we had made and tested over 100 purines in the *L. casei* screen (23) and discovered that the substitution of oxygen by sulfur at the 6-position of guanine and hypoxanthine produced inhibitors of purine utilization. 6-Mercaptopurine (6-MP) and 6-thioguanine (TG) were tested at the Sloan-Kettering Institute, with whom we had established a collaboration, and were found to be active against a wide spectrum of rodent tumors and leukemias. Of special interest was the finding by Clarke (24) that 6-MP-treated tumors, although they had not regressed completely in the host mouse, were not transplantable into other mice. After some animal toxicology studies by Philips et al. (25), Burchenal proceeded rapidly to clinical trial with 6-mercaptopurine (6-MP) in children with acute leukemia (26). At that time the only drugs available for the treatment of these terminally ill children were methotrexate and steroids and the median life expectancy was between 3 and 4 months; only 30% lived for as long as one year. The findings that 6-MP could produce complete remissions of acute leukemia in these children, although most of them relapsed at various intervals thereafter, led the Food and Drug Administration to approve the drug for this use in 1953, a little more than two years after its synthesis and microbiological investigation. A symposium on 6-MP was held at the New York Academy of Sciences in 1954 (27). The addition of 6-MP to the antileukemia armamentarium increased the median survival time to 12 months in these children, and a few remained in remission for years with 6-MP and steroids. This convinced us, as well as many other investigators in the cancer field, that antimetabolites of nucleic acid bases were fruitful leads to follow. Today 6-MP remains one of the dozen or more drugs found useful in the treatment of acute leukemia. With the use of combination chemotherapy with three or four drugs to produce and consolidate remission, plus several years of maintenance therapy with 6-MP and methotrexate, almost 80% of children with acute leukemia can now be cured.

Although we felt we were on the right track in 1952, there were still many unanswered questions. How did 6-MP work? What was the reason for its differential effect on neoplastic cells? How could one improve this differential effect? Reversal studies with 6-MP in *L. casei* did not pinpoint antagonism for any single purine. The inhibition was reversed by hypoxanthine, adenine, guanine and xanthine (28). However, studies with a 6-mercaptopurine-resistant strain of *L. casei* revealed that 6-MP was unable to utilize hypoxanthine for growth (29). Again, as with the earlier studies with 2,6-diaminopurine, we concluded that 6-MP and hypoxanthine were

anabolized by the same enzyme and that interference with purine interconversions at the nucleotide level were involved (30). In 1955, (two years after the introduction of 6-MP into clinical use) the enzyme which converts hypoxanthine and 6-MP to their respective nucleotides was identified as hypoxanthine phosphoribosyltransferase (HGPRT) (18). Also in the mid-fifties the pioneering work of Greenberg (31) and of Buchanan (32,33) revealed the pathways of the biosynthesis of purines and the importance of hypoxanthine ribonucleotide (inosinic acid, IMP) as the first purine nucleotide formed in this biosynthetic pathway. It took a number of investigators and a period of years to unravel all of the pathways in which the nucleotide of 6-MP, thioinosinic acid (TIMP), and nucleotides derived from TIMP participated as substrates and inhibitors (34). These are summarized in Figure 1. Based on our current knowledge of enzyme inhibition constants and the concentrations of the various nucleotides achieved with the therapeutic regimens, the principal sites of action appear to be feedback inhibition of *de novo* purine synthesis (particularly by methylthioinosinic acid), inhibition of inosinate dehydrogenase, and incorporation into DNA in the form of thioguanine (35). Selectivity for neoplastic cells probably depends on the levels of the individual anabolic and catabolic enzymes. Catabolic enzyme levels are generally much lower in tumor cells than in normal cells. In addition, mitotic rate, drug transport and metabolite pool sizes can be responsible for selective toxicity.

While these biochemical studies were going on, we studied the metabolic fate of 6-MP, first in mice (36) and then in humans (37). Pharmacokinetic and metabolic studies were then in their infancy, perhaps because the methodology for separation of metabolites and the counting of radioactive samples as thin films in a flow Geiger counter were so tedious and time-consuming. Nevertheless, using Dowex-1 and Dowex-50 ion-exchange columns and paper chromatography, we investigated the fate of 6-MP *in vivo* and attempted to discover whether it was possible to modify this metabolism and thus improve the efficacy of 6-MP. We continued to synthesize derivatives of 6-MP and thioguanine and investigate structure-activity relationships (38-40). Thioguanine, which we had synthesized earlier than 6-MP, was more active but also more toxic (25). It was also more difficult to synthesize and, since its mechanism of action appeared to be similar to that of 6-MP, its metabolic fate and clinical activity was explored somewhat later (41-43). Thioguanine later found its main utility in the treatment of acute myelocytic leukemia in adults, in combination with cytosine arabinoside.

Studies of the urinary metabolites of 6-MP revealed that extensive metabolic transformations occurred *in vivo* (36,37,44-46). The single product present in highest amount was 6-thiouric acid, formed by the action of xanthine oxidase on 6-MP. In addition, there were various substances in which the sulfur had been methylated, and the methylthio derivative had been oxidized on the sulfur or on the purine ring. A considerable amount of the sulfur had been removed and converted by oxidation to

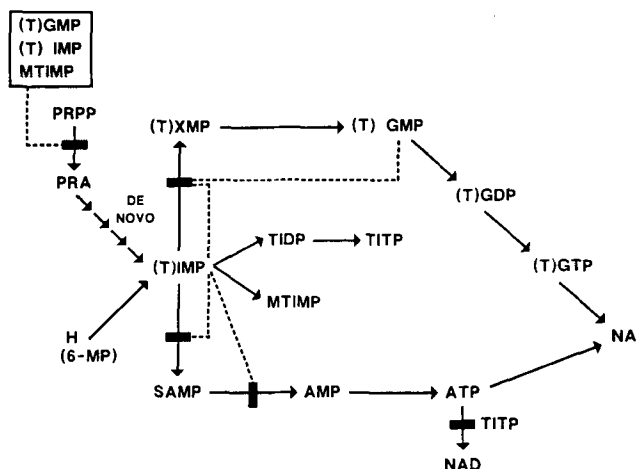

FIG. 1. Pathways in the anabolism of 6-MP and loci of action of the nucleotides derived from 6-MP. In addition, TGDP is converted to dTGDP and dTGTP for incorporation into DNA.

inorganic sulfate, which also appeared as ethereal sulfates. Very little 6-MP was excreted unchanged.

In an attempt to modify the metabolism of 6-MP, we introduced substituents at the 2 and/or 8 positions of the purine ring and on the ring nitrogens. This led to the loss of antitumor activity, with the exception of the 2-amino-6-mercapto derivative, thioguanine, which we had previously found to have strong antimetabolic activity. Attempts were then made to protect the sulfur from oxidation and hydrolysis by blocking groups which might be removed intracellularly to release 6-MP, hopefully by some tumor-specific enzyme. The most successful compound to emerge from this approach was the 1-methyl-4-nitro-5-imidazolyl derivative, the compound now known as azathioprine (Imuran®). This compound acts as a pro-drug for 6-MP which, due to the proximity of the ortho-nitro group, is subject to attack by sulphydryl groups and other nucleophiles (45-49) (Figure 2). In particular, the glutathione present in red cells reacts with azathioprine, releasing 6-MP back into the plasma (47). This compound had a better therapeutic index in mice bearing adenocarcinoma 755, being as active as 6-MP but less toxic (59). In patients with leukemia, however, the chemotherapeutic index of 6-MP and azathioprine were similar (51).

#### IMMUNOSUPPRESSION AND TRANSPLANTATION

In 1958 a new horizon appeared. Robert Schwartz, working with William Dameshek in Boston, investigated the effect of 6-MP on the immune response, based on the rationale that the immunoblastic lymphocyte formed during an immune response, closely resembled leukemic lymphocytes. Schwartz showed that when 6-MP was administered to rabbits for several days, beginning with the time of injection of a foreign antigen, e.g. bovine serum albumin, they were unable to mount an antibody response to that antigen (52). He worked out the importance of drug dose and timing and showed that 6-MP was most effective when treatment was started at the

time of antigen administration (52,53). He also demonstrated that animals could be made tolerant to a particular antigen while still retaining immunological reactivity to other antigens (54). At Schwartz's instigation, we set up an immunological screening test that consisted of measuring the antibody response of mice to sheep red cells (55,56). It enabled us to identify new active agents, synergistic combinations of drugs, and to show that immunosuppression was greater at higher doses of antigen and of drug.

Roy Calne, a young British surgeon, stimulated by Schwartz's papers, decided to examine the effect of 6-MP on kidney transplant rejection in dogs. He obtained a 44-day survival of a kidney from an unrelated donor in a dog given daily doses of 6-MP (57). This was considerably longer than the expected 9 to 10 day graft survival in control animals. When Calne asked us for compounds related to 6-MP which he might investigate, we suggested that azathioprine might have some advantages. The studies which followed showed azathioprine to be superior to 6-MP for preventing rejection of canine kidney homografts (58,59). Successful transplantation of kidneys to unrelated recipients became a reality in man in 1962, with regimens of immunosuppression consisting of azathioprine and prednisone (60). By 1977, the Kidney Registry had records of 25,000 kidney transplants done between 1965 and 1972 (61) and the numbers have continued to increase yearly (62,63). Today the procedure is considered therapeutic rather than experimental, and the importance of histocompatibility matching is recognized (63). Other organ transplants, e.g. liver, heart and lung, have likewise become possible. Other immunosuppressive drugs e.g., Cyclosporin, have come into use in recent years, but azathioprine remains a mainstay in kidney transplantation.

The immunosuppressive effects of azathioprine have been studied in a wide variety of immunological systems. The earlier work is reviewed in (64) and more recent studies in (65). Immunosuppressive drugs have also shown utility in the treatment of autoimmune disease. Remissions with 6-MP, thioguanine and azathioprine have been reported in autoimmune hemolytic anemia,

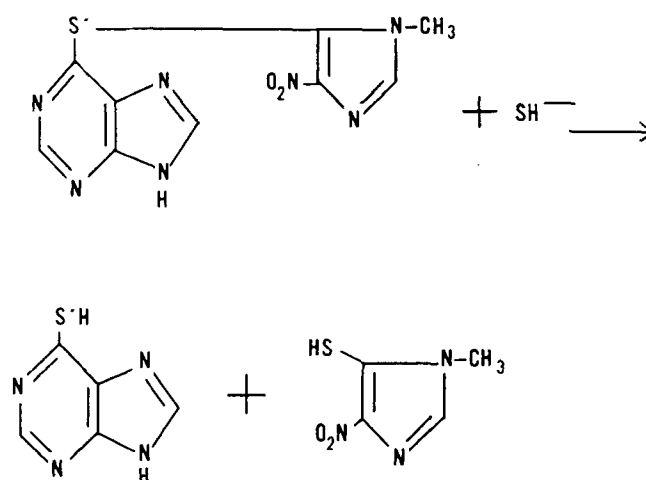

FIG. 2. Reaction of sulfhydryl ion upon azathioprine to release 6-MP. Reproduced from (46) with permission.

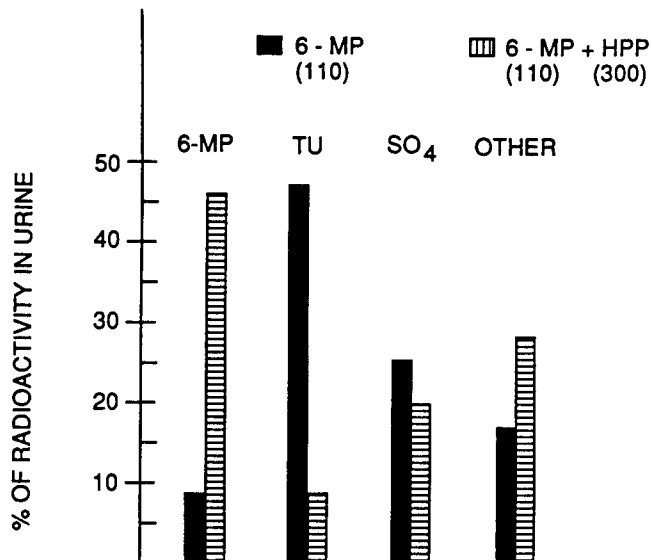

FIG. 3. Radioactive metabolites in the urine following administration of <sup>35</sup>S-6-MP (110 mg) to a patient with and without 300 mg of allopurinol (HPP). TU = thiouric acid. Reproduced from (71) with permission.

systemic lupus, and chronic active hepatitis (65). Azathioprine is now an approved drug for the treatment of severe rheumatoid arthritis (66).

#### GOUT AND HYPERURICEMIA

It was time now to try a new approach to the potentiation of 6-MP activity. Since we knew from metabolic studies that 6-thiouric acid was one of the principal products of 6-MP catabolism, it seemed possible that we could interfere with this oxidation by inhibiting the enzyme responsible for it, xanthine oxidase. In the early days of seeking antimetabolites for the natural purines in our laboratory, xanthine oxidase had been one of test enzymes. Doris Lorz had identified many substrates as well as inhibitors of this enzyme (7). These compounds had also been tested on *L. casei* and on animal tumors. To test for xanthine oxidase inhibition *in vivo*, we chose a compound that had no inhibitory effects on bacteria or tumors, was non-toxic, but which was a potent inhibitor of xanthine oxidase. This compound was the hypoxanthine analog, 4-hydroxypyrazolo (3,4-d) pyrimidine (allopurinol). When allopurinol was given to mice together with 6-MP, it did indeed inhibit the oxidation of 6-MP and potentiated the antitumor and immunosuppressive properties of 6-MP three to fourfold (45,67,68). Moreover, the toxicity of 6-MP to mice appeared to be potentiated only two-fold, so that the chemotherapeutic index of 6-MP had been increased. Was it possible that the same phenomenon would occur in man? With the collaboration of Wayne Rundles, we explored this possibility in patients with chronic granulocytic leukemia in whom the efficacy and metabolism of 6-MP could be investigated. As had happened in mice, the oxidation of 6-MP to thiouric acid was inhibited in a dose-related

manner and the antileukemic activity of 6-MP was potentiated proportionally (45,69-71). Figure 3 illustrates the four-fold reduction in thiouric acid and increase in 6-MP when 300 mg allopurinol was given together with 110 mg 6-MP. Later investigations (72) showed that the increased activity of 6-MP was accompanied by a proportional increase in toxicity. Thus, although less 6-MP was required to produce an antileukemic effect, the therapeutic index of 6-MP for leukemia remained unchanged.

Xanthine oxidase is responsible not only for the oxidation of 6-MP, but also for the formation of uric acid from hypoxanthine and xanthine (Fig. 4). Consequently, treatment with allopurinol produces a marked decrease in both serum and urinary uric acid (69,71,73,74). This presented the possibility of a unique approach to the treatment of gout and other forms of hyperuricemia.

It was recognized at the outset that the inhibition of an enzyme like xanthine oxidase *in vivo* might present some difficulties. First, there was the question as to whether the inhibitor had a sufficiently long half-life in the body to produce a persistent reduction in uric acid production. There was also the possibility that the inhibition would result in an unacceptable accumulation of the intermediates, hypoxanthine and xanthine, the latter compound being about as insoluble as uric acid. Moreover, it was possible that more enzyme would be induced by the presence of excess amounts of the intermediates, leading to the need for ever-increasing amounts of inhibitor. Finally, one had to consider carefully the long-term effects of this inhibitor, since gout patients would probably continue to take the drug for life. All of these possibilities were thoroughly examined, first in animals and then in man.

Allopurinol is not only a potent competitive inhibitor of xanthine oxidase but it is also a substrate (75) the oxidation resulting in the corresponding xanthine analog, oxypurinol (called alloxantine, oxoallopurinol, or oxipurinol in early papers) which is also a xanthine

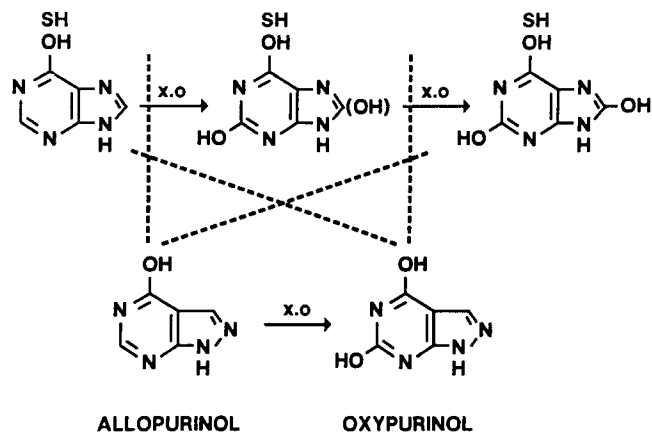

FIG. 4. Pathways in the oxidation of hypoxanthine and 6-MP by xanthine oxidase (x.o.) inhibited by allopurinol and oxypurinol. For 6-MP the intermediate is 8-hydroxy-6-MP; for hypoxanthine the intermediate is 2,6-dihydroxypurine (xanthine).

oxidase inhibitor (Fig. 4). Oxypurinol also has the unusual property of binding very tightly to the reduced form of the enzyme, thereby inactivating it (75,76). The enzyme activity can be restored by oxidation, which takes place slowly in the presence of air (76,77). Although allopurinol itself has a short half-life in plasma (about 90 to 120 minutes) oxypurinol has a very long half-life, 18 to 30 hours (75,78,79). This is due to the fact that oxypurinol is reabsorbed in the proximal tubule of the kidney (80). Consequently, steady-state levels of oxypurinol are achieved in a few days and uric acid concentrations can be maintained at the desired level by proper dose-adjustment (80). Because allopurinol is completely absorbed orally, whereas oxypurinol is not, allopurinol remains the ideal pro-drug for oxypurinol.

The fate of the intermediate oxypurines, hypoxanthine and xanthine, turned out to be a fascinating one. These oxypurines do not accumulate in the serum. In fact, their serum levels rise very little during allopurinol treatment (79,81). There are two reasons for this. One is that both hypoxanthine and xanthine can be reutilized for nucleic acid synthesis via the enzyme hypoxanthine-guanine phosphoribosyltransferase (HGPRT) (82,83). The nucleotides formed, IMP and XMP, are the normal intermediates for adenine and guanine nucleotides (AMP, GMP). Through a process of feedback inhibition IMP, AMP and GMP can reduce the *de novo* synthesis of purines by inhibiting PRPP-amidotransferase (84). Thus, the salvage of hypoxanthine and xanthine serves to regulate purine biosynthesis, reducing it when it is excessive. When the oxypurines are not reutilized, they are excreted by the kidney by glomerular filtration, since they are not reabsorbed by the kidney tubule to any significant degree (85,86).

Long-term studies with allopurinol in animals and in man have shown that new enzyme is not induced and that allopurinol is a safe and effective drug for long-term treatment (87). A few percent of patients develop a rash when taking allopurinol. Patients with poor kidney function require lower doses of drug because of the pharmacological properties of oxypurinol and its long half-life (88).

Allopurinol helps to alleviate several of the clinical problems associated with gout. The hyperuricemia of gout produces deposits of small crystals of uric acid in joints which results in extreme pain, or large deposits, tophi, which result in gouty arthritis and restricted joint movement. In patients who excrete excessive amounts of uric acid in the urine, urate stones often form in the kidney. With allopurinol it has been possible to prevent and reduce the tophaceous deposits and to prevent urate stone formation (74,81,87,89,90). Likewise, the secondary hyperuricemia which is associated with the therapy of malignancy can be reduced with allopurinol treatment (91).

#### ANTIPROTOZOAL EFFECTS OF ALLOPURINOL

I would like to digress at this point, to describe another use for allopurinol which materialized about 10 years

later, because it typifies the kind of chemotherapeutic selectivity which can be achieved with purine analogs as the result of differences in the specificities of parasitic and mammalian enzymes. The finding by Joseph Marr (92) that allopurinol inhibits the replication of *Leishmania donovani* led us into an extended collaboration with Marr to discover the biochemical basis for this unexpected activity (93-101). Leishmaniae and trypanosomes, like many other unicellular parasites, lack the ability to synthesize purines *de novo*. They do, however, have ample quantities of salvage enzymes which enable them to utilize preformed purines and nucleosides present in the mammalian blood stream. Leishmaniae and trypanosomes have large amounts of the enzyme HPRT capable of utilizing allopurinol as a substrate to a much greater extent than does the human enzyme (97). Moreover, the enzyme adenylosuccinate synthetase which has as its function the conversion of IMP to SAMP, the intermediate for AMP, has a broader substrate specificity than does the mammalian enzyme (96,101). The protozoal enzymes consequently convert allopurinol ribonucleotide to the adenylate analog, 4-aminopyrazolopyrimidine ribonucleotide, which is then converted to a di- and tri-phosphate and incorporated in RNA (93,94,98,100). In

#### MAJOR METABOLIC PATHWAYS OF ALLOPURINOL IN *TRYPANOSOMA* AND IN MAN

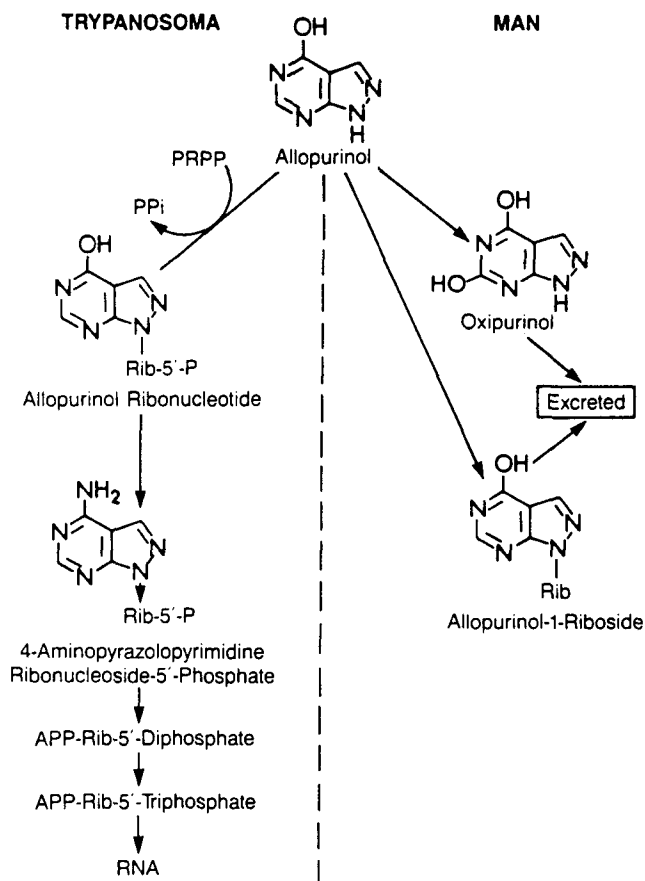

FIG. 5. Metabolic pathways of allopurinol in trypanosoma and man.

the mammalian host this amination does not occur and allopurinol is not incorporated into nucleic acids (102). The differences in the metabolism of allopurinol by the mammalian host and the trypanosomes is illustrated in Figure 5. Allopurinol has shown activity in the treatment of Leshmaniasis (103) and of Chagas' disease (caused by *Trypanosoma cruzi*) (104). Allopurinol riboside, a minor urinary metabolite of allopurinol in man, can likewise be converted by leishmaniae in this way (94), whereas allopurinol riboside is not further metabolized in man.

#### ANTIVIRAL DRUGS

In 1968 we decided to return to a path which had intrigued us as early as 1948, the path to antivirals. The antiviral activity of 2,6-diaminopurine had been provocative (22), although its toxicity had been discouraging. Meanwhile, the pursuit of 6-MP, thioguanine, azathioprine and allopurinol had occupied 20 years. When it was discovered that adenine arabinoside (ara-A) inhibited the growth of both DNA and RNA viruses (105), the information started a train of thought. Would the arabinoside of 2,6-diaminopurine be equally active? After all, diaminopurine had mimicked adenine in many reactions and could be converted to a nucleoside and nucleotide by adenine-metabolizing enzymes. Moreover, diaminopurine riboside was a poorer substrate for adenosine deaminase than was adenosine. It therefore seemed possible that the arabinoside might persist longer than ara-A, a compound which is rapidly deaminated *in vivo*.

Diaminopurine arabinoside was synthesized by Janet Rideout, and, since we did not have a virus laboratory on site at the time, we sent the compound to our colleague, John Bauer, in the Wellcome Research Laboratories in the U.K. for antiviral screening. In a few weeks he informed us that this compound was highly active against both herpes simplex virus and vaccinia virus. Moreover, the compound was less cytotoxic to mammalian cells than ara-A. Thus began our antiviral odyssey. For several years my group pursued studies on the purine arabinosides, exploring structure-activity relationships, seeking better synthetic methods, and doing metabolic studies in mice (106). Bauer and Collins studied the activity of these compounds in rabbits and mice (106). We found that diaminopurine arabinoside (ara-DAP) was deaminated to guanine arabinoside in mice and that the guanine derivative (ara-G) was as active an antiviral as ara-DAP. In this respect, ara-G had an advantage over the deamination product of ara-A, hypoxanthine arabinoside, which had very poor antiviral activity. We were not certain whether this advantage was sufficient to warrant the full-scale development of ara-DAP.

In 1970 our laboratories moved to North Carolina and Howard Schaeffer joined us as head of the Organic Chemistry Department. He had been studying analogs of adenosine as substrates and inhibitors of the enzyme adenosine deaminase, and had examined a variety of acyclic side chains on the 9-position of adenine to determine what changes the enzyme would tolerate in a substrate (107). He found that 9-(2-hydroxy-

ethoxymethyl)adenine could still serve as a substrate for adenosine deaminase. This suggested that other enzymes might also recognize such a side chain as a pentose and that nucleoside analogs of this kind might have antimetabolite properties.

When the acyclic adenosine analog was tested in the antiviral screen, it showed antiherpetic activity *in vitro* at about twice the concentration of ara-A. The antiviral program now concentrated on the acyclic nucleoside analogs, with the syntheses conducted by Schaeffer and Beauchamp, the antiviral testing by Bauer and Collins, and the mechanisms of action, enzymology and *in vivo* metabolism by my group (108,109). As was the case with the purine arabinosides, the 2,6-diaminopurine analog proved highly active on herpes simplex virus *in vivo* as well as *in vitro*. However, unexpectedly, the guanine analog, acyclovir (acycloguanosine), was over 100 times as active as the diaminopurine compound (109). Acyclovir is a metabolic product of the diaminopurine derivative, formed by the action of adenosine deaminase and is undoubtedly responsible for the antiviral activity of the diaminopurine compound observed *in vivo* (110-112).

#### ACYCLOVIR

One of the most intriguing aspects of the antiviral activity of acyclovir (ACV) is not only its high potency but its unusual degree of selectivity (Figure 6) (108,109,113-115). It is highly active against herpes simplex virus, types 1 and 2, and varicella zoster virus. It has activity against several other herpes type viruses, e.g., Epstein-Barr virus, pseudorabies, but only slight activity against the human cytomegalovirus (HCMV). It is not cytotoxic to the mammalian cells in which these viruses are grown at concentrations hundreds of times greater than the concentrations required for antiviral activity. Moreover, the compound is inactive against other DNA viruses, e.g. vaccinia, as well as RNA viruses (109). We decided that it was highly important to determine the reason for this unusual selectivity, since this would undoubtedly offer exploitable information about the herpes viruses. In order to do these biochemical studies effectively, we set up a virus laboratory in-house with Phillip Furman as its head. Radioactive acyclovir labeled in the 8-position of the guanine with  $^{14}\text{C}$  or with  $^3\text{H}$  in the

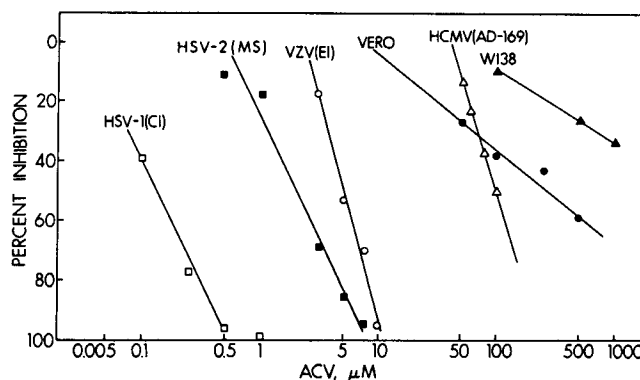

FIG. 6. Dose response curves of various viruses and cells to ACV. Reproduced from (108) with permission.

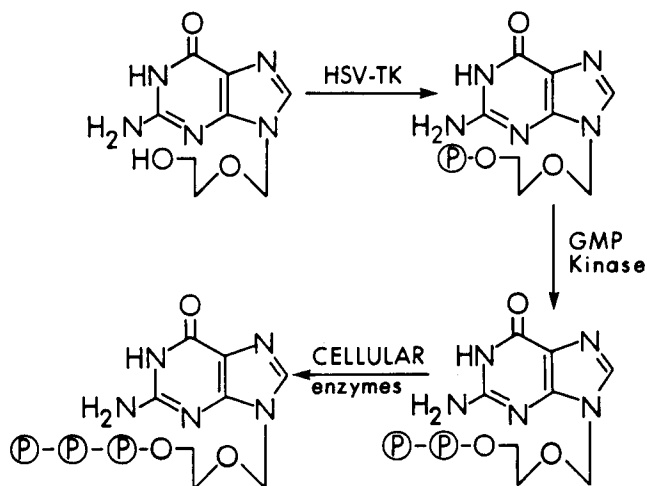

FIG. 7. Pathways for the formation of ACV mono-di- and triphosphates. Reproduced from (108) with permission.

side chain was synthesized. Vero cells, uninfected or infected with herpes simplex virus type (HSV-1), were incubated with both types of radioactive acyclovir for 7 hours. Extracts of these cells were then examined by high pressure liquid chromatography. The extracts of the uninfected cells showed only the presence of unchanged acyclovir. In the HSV-infected cells three new radioactive compounds were formed (108). These products were identified by enzymatic methods as the mono-, di and triphosphates (ACV-MP, ACV-DP, ACV-TP) of acyclovir, and this was later confirmed by comparison with authentic synthetic samples. The enzyme responsible for the conversion of acyclovir to its monophosphate was laboriously isolated, purified and identified by James Fyfe as a herpesvirus-specified thymidine kinase (108,116). While this enzyme had been reported to be formed in herpesvirus-infected cells, it was unexpected that an acyclic nucleoside of guanine could serve as its substrate. Nevertheless, this proved to be the case. A similar enzyme is specified by the varicella zoster virus. Once the first phosphate has been added, the second phosphate is added by cellular guanylate kinase (117) while several other cellular kinases can add the third phosphate (118). Since the cellular thymidine kinase can not use acyclovir as a substrate, very little ACV-TP is formed in uninfected cells (108,119). The small amount of phosphorylation which occurs in normal cells is due to a 5'-nucleotidase (120). The pathways for the formation of ACV-TP are shown in Figure 7.

When it was apparent that the active antiviral compound was ACV-TP, the interaction of this compound with viral and cellular DNA polymerases was investigated. ACV-TP proved to be a more potent inhibitor of the herpes virus DNA polymerase than of cellular DNA polymerase- $\alpha$  (121,122). The quantitative aspects of these differences in the amounts of ACV-TP formation and DNA polymerase inhibition ( $K_i$  value) by ACV-TP in virus-infected cells and uninfected cells are illustrated in Figure 8 (123). Moreover, ACV-TP serves as a substrate for the herpes virus DNA polymerase but chain termination occurs when it is

incorporated, because of the absence of the 3'-hydroxyl group needed for chain elongation (113). Thus, only very small fragments of viral DNA are formed (124). In addition, ACV-TP serves not only to inhibit, but also to inactivate, the viral DNA polymerase following the formation of the enzyme-template-acyclovir monophosphate complex (125). This inactivation does not occur with cellular DNA polymerase.

The high selectivity of acyclovir for those herpes viruses which induce a herpes-specified thymidine kinase can thus be explained. This enzyme has proved to be a very useful tool for determining the structural requirements for other potential substrates of this enzyme (126). Its absence or alteration also explains the resistance of some herpes virus isolates to acyclovir (127,128,129). On the other hand, transfection of cells with a portion of the herpesvirus genome containing the HSV thymidine kinase gene transforms normally resistant cells to ACV-sensitive cells (130). Resistance to ACV may also result from mutations in the viral DNA polymerase (127,128,129).

Epstein-Barr virus and human cytomegalovirus infection do not induce a specific kinase capable of phosphorylating acyclovir. However, the DNA polymerase of Epstein-Barr virus is exquisitely sensitive to the small amount of ACV-TP formed in EBV-infected cells (131). Interestingly, although HCMV-infected cells do not phosphorylate acyclovir to any extent, they do phosphorylate the closely related acyclovir derivative, ganciclovir, (formerly called BW B759U, DHPG, and 2'NDG) which has an extra hydroxymethyl group on the side chain. Consequently, ganciclovir has proven to be a much better inhibitor of HCMV replication than acyclovir (132-134).

Investigation of the pharmacokinetics and metabolism of acyclovir in several animal species and then in man revealed that it was a remarkably stable compound. Only two metabolites were found, the 2-carboxymethoxymethylguanine (CMMG) and 8-hydroxyacyclovir (135). In man, the carboxy derivative CMMG accounted for 9-14% of an intravenous

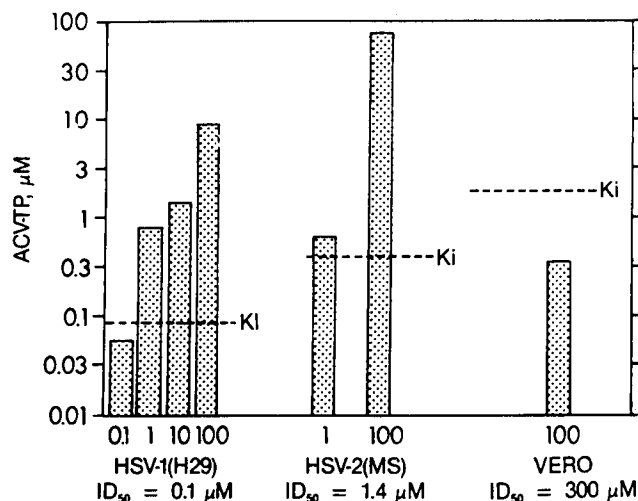

FIG. 8. Amounts of ACV-triphosphate formed in uninfected, HSV-1 and HSV-2 infected Vero cells in the presence of varying concentrations ( $\mu\text{M}$ ) of ACV. Dotted lines represent the  $K_i$  values for the individual DNA polymerases.  $\text{ID}_{50}$  values are concentrations for 50% inhibition of plaque formation. Reproduced from (123) with permission.

TABLE 1  
EFFECT OF ACV ON FIRST EPISODES  
ON GENITAL HERPES

Route	Median duration in days (ACV/placebo)			Ref.
	Virus Shedding	Pain	Healing	
i.v.	2/13	3/7	9/21	(144)
p.o.	1/13	4/8	6/11	(145)
p.o. <sup>a</sup>	3.9/13.4	2.8/3.4	9.5/13.7	(146)

<sup>a</sup>Women only. Mean duration.

dose of acyclovir, while essentially none of the 8-hydroxy metabolite appeared in the urine (136,137). In other species there were somewhat increased amounts of both metabolites (135,137,138). Acyclovir has a plasma half-life of approximately three hours (139) so that an intravenous infusion is generally given every eight hours. Because acyclovir is excreted at about twice glomerular filtration rate and has a limited solubility in water (2.5 mg/ml at 37° C) it is administered as a one-hour intravenous infusion rather than as a bolus injection. The compound is also active topically and orally. Although the oral bioavailability is limited, the blood levels attained by oral administration of acyclovir are adequate for therapeutic efficacy against herpes simplex and varicella zoster viruses (140).

The compound is distributed in all body tissues and crosses the blood-brain barrier (109,135,141). Toxicology studies in mice, rats and dogs showed the drug to be non-toxic as doses well above those required for therapeutic efficacy (142).

Acyclovir has now been in clinical use for about eight years and it seems appropriate to mention some of the areas in which it has decreased suffering and saved lives. First episodes of genital herpes infections are characterized by pain, prolonged viral excretion, and slow healing of lesions. Acyclovir given by either the intravenous or oral routes produces a significant alleviation of symptoms and decreases the time of viral shedding and time to healing (Table 1) (143). Recurrent episodes of genital herpes are generally much shorter and less severe than the initial one. Therefore, the benefits of acyclovir treatment appear to be less dramatic. However, in a study in which patients initiated oral therapy, there was a significant difference in new lesion formation, 23% on placebo, 6.5% on ACV (147). For patients with frequently recurring genital herpes, e.g., once a month, of several years duration, it has been possible to decrease the frequency of recurrence to a mean of 1.8 episodes during the first year and 1.4 episodes during the second year by oral prophylaxis with acyclovir

TABLE 2

EFFECT OF INTRAVENOUS ACV IN HSV INFECTIONS  
IN IMMUNOCOMPROMISED PATIENTS

Patients	Median duration in days (ACV/placebo)		
	Virus Shedding	Pain	Healing
all (97)	2.8/16.8	8.9/13.1	13.7/20.1
Bone marrow transplants (34)	3/17	10/16	14/28

(148). The percentage of patients having no recurrences in a year of oral prophylactic therapy was 45-50% (149).

Herpes zoster, commonly known as shingles, is caused by a reactivation of latent varicella zoster virus. It produces severe pain during the acute two to three week episode, as well as a post-herpetic neuralgia months later in about 10 percent of patients. Acyclovir causes a significant decrease in the duration of acute pain but has little effect on the post-herpetic neuralgia (150). In immunocompromised individuals, herpes zoster can produce serious sequelae in the form of progressive skin dissemination and visceral disease. The latter can be fatal in a small percentage of patients. Intravenous treatment with acyclovir has effectively prevented this dissemination (151).

Herpes simplex infections in immunosuppressed individuals is a serious medical problem. Virus continues to be shed for a long time and healing is slow. In two studies which involved 97 immunocompromised patients (152) with a variety of diseases and 34 bone marrow transplant recipients (153) the effects of intravenous acyclovir treatment on viral shedding, pain and time to healing were highly significant (Table 2). In bone marrow transplant patients and in leukemic patients, prophylaxis with acyclovir has made it possible to prevent the reactivation of latent virus during therapy so that the patients can remain free of herpetic episodes during the period of maximum immunosuppression (154,155). The treatment of herpes encephalitis, a frequently fatal disease, with intravenous acyclovir has been successful in a large percentage of patients if begun the patient is comatose (156,157).

In addition to the clinical utility of acyclovir, the lessons learned from its development have proven to be extremely valuable for future antiviral research. In depth studies of mechanisms of action have led to a better understanding of the enzymatic differences between normal and virus-infected cells. It has given impetus to the search for other viral-specific enzymes which are capable of therapeutic application.

In my attempt to cover 40 years of research on purines and purine analogs, I have been able to give you only a bird's eye view. However, I hope that I have successfully conveyed our philosophy that chemotherapeutic agents are not only ends in themselves but also serve as tools for unlocking doors and probing Nature's mysteries. This approach has served us well and has led into many new areas of medical research. Selectivity remains our aim and understanding its basis our guide to the future.

#### REFERENCES

1. D. D. Wood, *Brit. J. Exp. Pathol.* **21**, 74 (1940).
2. P. Fildes, *Lancet* **1**, 955 (1940).
3. G. H. Hitchings, G. B. Elion, E. A. Falco, P. B. Russell, M. B. Sherwood, H. VanderWerff, *J. Biol. Chem.* **183**, 1 (1950).
4. G. H. Hitchings, G. B. Elion, E. A. Falco, P. B. Russell, H. VanderWerff, *Ann. N.Y. Acad. Sci.* **52**, 1318 (1950).
5. H. M. Kalckar, *J. Biol. Chem.* **167**, 461 (1947).
6. G. H. Hitchings, E. A. Falco, *Proc. Natl. Acad. Sci. U.S.A.* **30**, 294 (1944).
7. D. C. Lorz, G. H. Hitchings, *Fed. Proc.* **9**, 197 (1950).
8. R. B. Angier, J. H. Boothe, B. L. Hutchings, et al. *Science* **103**, 667 (1946).
9. G. H. Hitchings, E. A. Falco, M. B. Sherwood, *Science* **102**, 251 (1945).
10. G. B. Elion, G. H. Hitchings, *J. Biol. Chem.* **185**, 651 (1950).
11. G. H. Hitchings, G. B. Elion, H. VanderWerff, H., E. A. Falco, *J. Biol. Chem.* **174**, 765 (1948).



12. G. H. Hitchings, G. B. Elion, H. VanderWerff, *J. Biol. Chem.* **174**, 1037 (1948).
13. H. C. Carrington, *J. Chem. Soc.* 124 (1944).
14. G. B. Elion, E. Burgi, G. H. Hitchings, *J. Am. Chem. Soc.* **74**, 411 (1952).
15. G. B. Elion, G. H. Hitchings, *J. Am. Chem. Soc.* **77**, 1676 (1955).
16. G. B. Elion, G. H. Hitchings, *J. Biol. Chem.* **187**, 511 (1950).
17. G. B. Elion, H. VanderWerff, G. H. Hitchings, M. E. Balis, D. H. Levin, J. B. Brown, *J. Biol. Chem.* **200**, 7 (1953).
18. A. Kornberg, I. Lieberman, E. S. Simms, *J. Biol. Chem.* **215**, 417 (1955).
19. J. H. Burchenal, A. Bendich, J. B. Brown, G. B. Elion, G. H. Hitchings, C. P. Rhoads, et al. *Cancer* **2**, 119 (1949).
20. J. J. Biesele, R. E. Berger, A. Y. Wilson, G. H. Hitchings, G. B. Elion, *Cancer* **4**, 186 (1951).
21. J. H. Burchenal, D. A. Karnofsky, E. M. Kingsley-Pillers, et al. *Cancer* **4**, 549 (1951).
- 22a. R. L. Thompson, M. L. Wilkin, G. H. Hitchings, G. B. Elion, E. A. Falco, P. B. Russell, *Science* **110**, 454 (1949).
- 22b. R. L. Thompson, M. L. Price, S. A. Menton, Jr., G. B. Elion, G. H. Hitchings, *J. Immunol.* **66**, 529 (1950).
23. G. B. Elion, G. H. Hitchings, H. VanderWerff, *J. Biol. Chem.* **192**, 505 (1951).
24. D. A. Clarke, F. S. Phillips, S. S. Sternberg, S. S., C. C. Stock, G. B. Elion, G. H. Hitchings, *Cancer Res.* **13**, 593 (1953).
25. F. S. Phillips, S. S. Sternberg, L. Hamilton, D. A. Clarke, *Ann. N.Y. Acad. Sci.* **60**, 283 (1954).
26. J. H. Burchenal, M. L. Murphy, R. R. Ellison, et al. *Blood*, **8**, 965 (1953).
27. 6-Mercaptopurine, Ed. C. P. Rhoads, *Ann. N.Y. Acad. Sci.* **60**, 183 (1954).
28. G. B. Elion, S. Singer, G. H. Hitchings, *Ann. N.Y. Acad. Sci.* **60**, 200 (1954).
29. G. B. Elion, S. Singer, G. H. Hitchings, *J. Biol. Chem.* **204**, 35 (1953).
30. M. E. Balis, D. H. Levin, G. B. Brown, G. B. Elion, H. C. Nathan, G. H. Hitchings, *Arch. Biochem. Biophys.* **71**, 358 (1957).
31. G. R. Greenberg, J. Jaenicke, L. In: *The Chemistry and Biology of Purines*. G. E. W. Wolstenholme, C. M. O'Connor (Churchill, London, 1957) pp. 204-232.
32. J. M. Buchanan, J. G. Flaks, S. C. Hartman, B. Levenberg, L. N. Lukens, L. Warren, in: *The Chemistry and Biology of Purines*, Ed. G. E. W. Wolstenholme and C. M. O'Connor (Churchill, London, 1957) pp. 233-252.
33. J. B. Buchanan, S. C. Hartman, *Adv. Enzymol.* **21**, 199 (1959).
34. G. H. Hitchings, G. B. Elion, in: *Cancer Chemotherapy II, Twenty-Second Hahnemann Symposium*, Ed. I. Brodsky, S. B. Kahn, J. H. Moyer, (Grune and Stratton, New York, 1972) pp. 23-32.
35. G. B. Elion, in: *Pharmacological Basis of Cancer Chemotherapy (Williams and Wilkins, Baltimore, 1975) pp. 547-564.*
36. G. B. Elion, S. Bieber, G. H. Hitchings, *Ann. N.Y. Acad. Sci.* **60**, 297 (1954).
37. L. Hamilton, G. B. Elion, *Ann. N.Y. Acad. Sci.* **60**, 304 (1954).
38. G. B. Elion, *Proc. Royal Soc. Med.* **50**, 7 (1957).
39. D. A. Clarke, G. B. Elion, G. H. Hitchings, C. C. Stock, *Cancer Res.* **18**, 445 (1958).
40. G. B. Elion, I. Goodman, W. Lange, G. H. Hitchings, *J. Am. Chem. Soc.* **81**, 1898 (1959).
41. G. B. Elion, S. Bieber, G. H. Hitchings, *Cancer Chemother. Rep.* **8**, 36 (1960).
42. G. B. Elion, S. W. Callahan, G. H. Hitchings, G. H., R. W. Rundles, *Cancer Chemother. Rep.* **8**, 47 (1960).
43. G. B. Elion, S. W. Callahan, G. H. Hitchings, R. W. Rundles, in: *Proc. VIIIth International Congress Hematology*, Vol I (Pan-Pacific Press, Tokyo, 1961) pp. 642-645.
44. G. B. Elion, S. Mueller, G. H. Hitchings, *J. Am. Chem. Soc.* **81**, 3042 (1959).
45. G. B. Elion, S. Callahan, R. W. Rundles, G. H. Hitchings, *Cancer Res.* **23**, 1207 (1963).
46. G. B. Elion, *Fed. Proc.* **26**, 898 (1967).
47. P. de Miranda, L. M. Beacham, III, T. H. Creagh, G. B. Elion, *J. Pharmacol. Exp. Ther.* **187**, 588 (1973).
48. G. B. Elion, G. H. Hitchings, G. H., in: *Antineoplastic and Immunosuppressive Agents, Handbook of Experimental Pharmacology*. Vol. **38/2**, Ed. A. C. Sartorelli, D. G. Jones (Springer-Verlag, Berlin, 1975) pp. 404-425.
49. P. de Miranda, L. M. Beacham, III, T. H. Creagh, G. B. Elion, *J. Pharmacol. Exp. Ther.* **195**, 50 (1975).
50. G. B. Elion, S. Callahan, S. Bieber, R. W. Rundles, *Cancer Chemother. Rep.* **14**, 93 (1961).
51. R. W. Rundles, J. Laszlo, T. Itoga, G. B. Hobson and F. E. Garrison, Jr., *Cancer Chemother. Rep.* **14**, 99 (1961).
52. R. Schwartz, J. Stack, W. Dameshek, *Proc. Soc. Exp. Biol. Med.* **99**, 164 (1958).
53. D. Chanmougan, R. S. Schwartz, *J. Exp. Med.* **124**, 363 (1966).
54. R. Schwartz, W. Dameshek, *Nature* **183**, 1682 (1959).
55. H. C. Nathan, S. Bieber, G. B. Elion, G. H. Hitchings, *Proc. Soc. Exp. Biol. Med.* **107**, 796 (1961).
56. S. Bieber, G. B. Elion, G. H. Hitchings, D. C. Hooper, H. C. Nathan, *Proc. Soc. Exp. Biol. Med.* **111**, 334 (1962).
57. R. Y. Calne, *Lancet* **I**, 417 (1960).
58. R. Y. Calne, *Transplant Bull.* **28**, 65 (1961).
59. R. Y. Calne, G. P. J. Alexandre, J. E. Murray, *Ann. N.Y. Acad. Sci.* **99**, 743 (1962).
60. J. E. Murray, J. P. Merrill, J. H. Harrison, R. E. Wilson and G. J. Dammin, *N. Engl. J. Med.* **268**, 1315 (1963).
61. The Twelfth Report of the Human Renal Transplant Registry, Advisory Committee to the Renal Transplant Registry. *J. Am. Med. Assoc.* **233**, 787 (1975).
62. S. T. Perdue, P. I. Terasaki, S. Cats, M. R. Mickey, *Transplantation* **36**, 658 (1983).
63. H. Takiff, D. J. Cook, N. S. Himaya, M. R. Mickey and P. I. Terasaki, *Transplantation* **45**, 410 (1988).
64. G. H. Hitchings, G. B. Elion, *Pharmacol. Rev.* **15**, 365 (1963).
65. G. Wolberg, in: *Pharmacology of Lymphocytes Handbook of Experimental Pharmacology*, Vol. **85**, Ed. M. A. Bray and J. Morley, (Springer-Verlag, Berlin, 1988) pp. 517-533.
66. T. Hunter, M. B. Urowitz, D. A. Gordon, H. A. Smythe, M. A. Ogrzyzlo, *Arthritis Rheum.* **18**, 15 (1975).
67. G. B. Elion, S. W. Callahan, G. H. Hitchings, R. W. Rundles, J. Laszlo, *Cancer Chemother. Rep.* **16**, 197 (1962).
68. G. B. Elion, S. Callahan, H. Nathan, S. Bieber, R. W. Rundles, G. H. Hitchings, *Biochem. Pharmacol.* **12**, 85 (1963).
69. R. W. Rundles, J. B. Wyngaarden, G. H. Hitchings, G. B. Elion and H. R. Silberman, *Trans. Assoc. Am. Physicians* **76**, 126 (1963).
70. R. W. Rundles, *Ann. Rheum. Dis.* **25**, 615 (1966).
71. G. H. Hitchings, G. B. Elion, *Cancer Res.* **45**, 2415 (1985).
72. W. R. Volger, J. A. Bain, C. M. Huguley, Jr., H. G. Palmer, Jr., M. E. Lowrey, *Am. J. Med.* **40**, 548 (1966).
73. G. H. Hitchings, *Ann. Rheum. Dis.* **25**, 601 (1966).
74. Symposium on Allopurinol, Ed. J. T. Scott, *Ann. Rheum. Dis.* **25**, 599 (1966).
75. G. B. Elion, *Ann. Rheum. Dis.* **25**, 608 (1966).
76. V. Massey, H. Komai, G. Palmer, G. B. Elion, *J. Biol. Chem.* **245**, 2837 (1970).
77. V. Massey, H. Komai, G. Palmer, G. B. Elion, *Vitam. Horm.* **28**, 505 (1970).
78. G. B. Elion, A. Kovensky, G. H. Hitchings, E. Metz, R. W. Rundles, *Biochem. Pharmacol.* **15**, 863 (1966).
79. G. B. Elion, in: *Uric Acid, Handbook of Experimental Pharmacology*, Vol. **51**, Ed. W. N. Kelley and I. M. Wiener (Springer-Verlag, Berlin, 1978) pp. 485-514.
80. G. B. Elion, T.-F. Yu, A. B. Gutman, G. H. Hitchings, *Am. J. Med.* **45**, 69 (1968).
81. T.-F. Yu, A. B. Gutman, *Am. J. Med.* **37**, 885 (1964).
82. R. Pomales, S. Bieber, R. Friedman, G. H. Hitchings, *Biochim. Biophys. Acta.* **72**, 119 (1963).
83. R. Pomales, G. B. Elion, G. H. Hitchings, *Biochim. Biophys. Acta.* **95**, 505 (1965).
84. J. B. Wyngaarden, D. M. Ashton, *J. Biol. Chem.* **234**, 1492 (1959).

85. S. Goldfinger, J. R. Klinenberg, J. E. Seegmiller, *J. Clin. Invest.* **44**, 623 (1965).
86. J. R. Klinenberg, S. E. Goldfinger, J. E. Seegmiller, *Ann. Intern. Med.* **62**, 639 (1965).
87. R. W. Rundles, *Arch. Intern. Med.* **145**, 1492 (1985).
88. G. B. Elion, F. M. Benezra, T. D. Beardmore, W. N. Kelley, in: *Purine Metabolism in Man III A*, Ed. A. Rapado, R. W. E. Watts, C. H. M. M. DeBruyn, (Plenum, New York, 1980) pp. 263-267.
89. R. W. Rundles, E. Metz, H. R. Silberman, *Ann. Intern. Med.* **64**, 229 (1966).
90. A. deVries, M. Frank, U. A. Liberman, O. Sperling, *Ann. Rheum. Dis.* **25**, 691 (1966).
91. I. H. Krakoff, *Arthritis Rheum.* **8**, 896 (1965).
92. M. A. Pfaller, J. J. Marr, *Antimicrob. Agents Chemother.* **5**, 469 (1974).
93. D. J. Nelson, C. J. I. Bugge, G. B. Elion, R. L. Berens, J. J. Marr, *J. Biol. Chem.* **254**, 3959 (1979).
94. D. J. Nelson, S. W. LaFon, J. V. Tuttle, et al. *J. Biol. Chem.* **254**, 11544 (1979).
95. J. Marr, R. Berens, D. Nelson, *Science* **201**, 1018 (1978).
96. T. Spector, T. E. Jones, G. B. Elion, *J. Biol. Chem.* **254**, 8422 (1979).
97. T. A. Krenitsky, G. W. Koszalka, J. V. Tuttle, J. V., D. L. Adamczyk, G. B. Elion, J. J. Marr, in: *Purine Metabolism in Man III B*, Ed. A. Rapado, R. E. Watts, C. H. M. M. DeBruyn, (Plenum, New York, 1980) pp. 271-276.
98. R. L. Berens, J. J. Marr, D. J. Nelson, *Biochem. Pharmacol.* **29**, 2397 (1980).
99. S. W. LaFon, D. J. Nelson, R. L. Berens, J. J. Marr, *Biochem. Pharmacol.* **31**, 231 (1982).
100. R. L. Berens, J. J. Marr, F. Steele De Cruz, D. J. Nelson, *Antimicrob. Agents Chemother.* **22**, 657 (1982).
101. T. Spector, R. L. Berens, J. J. Marr, *Biochem. Pharmacol.* **31**, 225 (1982).
102. D. J. Nelson, G. B. Elion, *Biochem. Pharmacol.* **24**, 1235 (1975).
103. P. A. Kager, P. H. Rees, B. T. Welde, et al. *Trans. R. Soc. Trop. Med. Hyg.* **75**, 556 (1981).
104. C. I. Meirovich, H. L. Montrull, R. H. Gallerano, R. R. Sosa, *Arq. Bras. Cardiol.* **45**, 217 (1985).
105. F. M. Schabel, Jr. *Chemotherapy* **13**, 321 (1968).
106. G. B. Elion, J. L. Rideout, P. de Miranda, P. Collins, D. J. Bauer, *Ann. N.Y. Acad. Sci.* **255**, 468 (1975).
107. H. J. Schaeffer, S. Gurwara, R. Vince, S. Bittner, *J. Med. Chem.* **14**, 367 (1971).
108. G. B. Elion, P. A. Furman, J. A. Fyfe, P. de Miranda, L. Beauchamp, H. J. Schaeffer, *Proc. Natl. Acad. Sci. U.S.A.*, **74**, 5716 (1977).
109. H. J. Schaeffer, L. Beauchamp, P. de Miranda, G. B. Elion, D. J. Bauer, P. Collins, *Nature* **272**, 583 (1978).
110. S. S. Good, P. de Miranda, *Fed. Proc.* **41**, 1733 (1982).
111. H. C. Krasny, S. H. T. Liao, S. S. Good, B. Petty, P. S. Lietman, *Clin. Pharmacol. Ther.* **33**, 256 (1983).
112. T. Spector, T. E. Jones, L. M. Beacham, III, *Biochem. Pharmacol.* **32**, 2505 (1983).
113. G. B. Elion, *Am. J. Med.* **73**(1A), 7 (1982).
114. P. Collins, *J. Antimicrob. Chemother.* **12**(Suppl. B), 19 (1983).
115. G. B. Elion, *J. Antimicrob. Chemother.* **12**(Suppl. B) 9 (1983).
116. J. A. Fyfe, P. M. Keller, P. A. Furman, R. L. Miller, G. B. Elion, *J. Biol. Chem.* **253**, 8721 (1978).
117. W. H. Miller, R. L. Miller, *J. Biol. Chem.* **255**, 7204 (1980).
118. W. H. Miller, R. L. Miller, *Biochem. Pharmacol.* **31**, 3879 (1982).
119. P. A. Furman, P. de Miranda, M. H. St. Clair, G. B. Elion, *Antimicrob. Agents Chemother.* **20**, 518 (1981).
120. P. M. Keller, S. A. McKee, J. A. Fyfe, *J. Biol. Chem.* **260**, 8664 (1985).
121. P. A. Furman, M. H. St. Clair, J. A. Fyfe, J. L. Rideout, P. M. Keller, G. B. Elion, *J. Virol.* **32**, 72 (1979).
122. M. H. St. Clair, P. A. Furman, C. M. Lubbers, G. B. Elion, *Antimicrob. Agents Chemother.* **18**, 741 (1980).
123. G. B. Elion, in: *Antiviral Chemotherapy: New Directions for Clinical Application and Research*, Ed. J. Mills, and L. Corey (Elsevier, New York) (1986) pp. 118-137.
124. P. V. McGuirt, J. E. Shaw, G. B. Elion, P. A. Furman, *Antimicrob. Agents Chemother.* **25**, 507 (1984).
125. P. A. Furman, M. H. St. Clair, T. Spector, *J. Biol. Chem.* **259**, 9575 (1984).
126. P. M. Keller, J. A. Fyfe, L. Beauchamp, et al. *Biochem. Pharmacol.* **30**, 3071 (1981).
127. L. E. Schnipper, C. S. Crumpacker, *Proc. Natl. Acad. Sci. U.S.A.* **77**, 2270 (1980).
128. P. A. Furman, D. M. Coen, M. H. St. Clair, P. A. Schaeffer, *J. Virol.* **40**, 936 (1981).
129. K. K. Biron, J. A. Fyfe, J. E. Noblin, G. B. Elion, *Am. J. Med.* **73**(1A), 383 (1982).
130. P. A. Furman, P. V. McGuirt, P. M. Keller, J. A. Fyfe, G. B. Elion, *Virology* **102**, 420 (1980).
131. J. S. Pagano, J. W. Sixbey, J.-C. Lin, *J. Antimicrob. Chemother.* **12**(Suppl. B) 113 (1983).
132. W. T. Ashton, J. D. Karkas, A. K. Field, R. L. Tolman, *Biochem. Biophys. Res. Commun.* **108**, 1716 (1982).
133. Y. C. Cheng, S. P. Grill, G. E. Dutschman, K. Narayama, K. F. Bastow, *J. Biol. Chem.* **258**, 12460 (1983).
134. K. K. Biron, S. C. Stanat, J. B. Sorrell, et al. *Proc. Natl. Acad. Sci. U.S.A.* **82**, 2473 (1985).
135. P. de Miranda, H. C. Krasny, D. A. Page, G. B. Elion, *J. Pharmacol. Exp. Ther.* **219**, 309 (1981).
136. P. de Miranda, S. S. Good, O. L. Laskin, H. C. Krasny, J. D. Connor, P. S. Lietman, *Clin. Pharmacol. Ther.* **30**, 662 (1981).
137. P. de Miranda, S. S. Good, H. C. Krasny, J. D. Connor, O. L. Laskin, P. S. Lietman, *Am. J. Med.* **73**(1A), 215 (1982).
138. S. S. Good, P. de Miranda, *Am. J. Med.* **73**(1A), 91 (1982).
139. P. de Miranda, R. J. Whitley, M. R. Blum, et al. *Clin. Pharmacol. Ther.* **26**, 718 (1979).
140. P. de Miranda, M. R. Blum, *J. Antimicrob. Chemother.* **12**(Suppl. B) 29 (1983).
141. M. R. Blum, S. H. T. Liao, P. de Miranda, *Am. J. Med.* **73**(1A), 186 (1982).
142. W. E. Tucker, *Am. J. Med.* **73**(1A), 27 (1982).
143. G. B. Elion, *Cancer Res.* **45**, 2943 (1985).
144. L. Corey, J. Benedetti, C. Critchlow, et al. *J. Antimicrob. Chemother.* **12**(Suppl. B), 79 (1983).
145. A. E. Nilsen, T. Aasen, A. M. Halsos, et al. *Lancet* **2**, 571 (1982).
146. Y. J. Bryson, M. Dillon, M. Lovett, et al. *N. Engl. J. Med.* **308**, 916 (1983).
147. R. C. Reichman, G. J. Badger, D. C. Mertz, et al. *J. Am. Med. Assoc.* **251**, 2103 (1984).
148. G. J. Mertz, L. Eron, R. Kaufman, et al. *Am. J. Med.* **85**(2A), 14 (1988).
149. H. R. Mattison, R. C. Reichman, J. Benedetti, et al. *Am. J. Med.* **85**(2A), 20 (1988).
150. B. Bean, C. Braun, *Lancet* **2**, 118 (1982).
151. H. H. Balfour, K. A. McMonigal, B. Bean, *J. Antimicrob. Chemother.* **12**(Suppl. B), 169 (1983).
152. J. D. Meyers, J. C. Wade, C. D. Mitchell, et al. *Am. J. Med.* **73**(1A), 229 (1982).
153. J. C. Wade, B. Newton, C. McLaren, et al. *Ann. Intern. Med.* **96**, 265 (1982).
154. R. Saral, W. H. Burns, O. L. Laskin, et al. *N. Engl. J. Med.* **305**, 63 (1981).
155. R. Saral, R. F. Ambinder, W. H. Burns, et al. *Ann. Intern. Med.* **99**, 773 (1983).
156. B. Skoldenberg, M. Forsgren, K. Alestig, et al. *Lancet* **2**, 707 (1984).
157. R. J. Whitley, C. A. Alford, M. S. Hirsch, et al. *N. Engl. J. Med.* **314**, 144 (1986).