

Electrical conductivity of skeletal muscle tissue: experimental results from different muscles *in vivo*

F. L. H. Gielen W. Wallinga-de Jonge K. L. Boon

Twente University of Technology, Department of Electrical Engineering, Bio-Information Group, PO Box 217,
7500 AE Enschede, The Netherlands

Abstract—For a quantitative EMG analysis reliable and unique values of the electrical conductivities of skeletal muscle tissue *in vivo* are indispensable. Literature values do not satisfy these criteria. In the paper experimental results of conductivity measurements (four-electrode technique) on muscles *in vivo* on which quantitative EMG experiments are also carried out, are reported. Depending on the interelectrode distance (IED) in the four-electrode technique the results appear to be either frequency dependent (IED = 0.5 mm) or frequency independent (IED ≤ 3.0 mm). The anisotropy value obtained with an IED of 0.5 mm is frequency dependent in the frequency range of EMG signals. Experimental results of different muscle types (white muscle, EDL rat and red muscle, soleus rat) appear to be significantly different.

Keywords—Electrical conductivity, Four-electrode technique, Skeletal muscle

Med. & Biol. Eng. & Comput., 1984, 22, 569–577

1 Introduction

THE potential measured at a certain distance from an electrophysiological source can be described by the electrical volume conduction theory (LORENTE DE NO, 1947; PLONSEY, 1969; ROSENFALCK, 1969). The results of such a theoretical description strongly depend on the spatial and temporal properties of the source and on the electrical properties of the surrounding medium. For this reason the theoretical description of signals such as the EMG, ECG and EEG is quite different.

For the study of EMG several specific models are reported in the literature (DIMITROV and DIMITROVA, 1974; GRIEP *et al.*, 1978; BOYD *et al.*, 1978; WANI and GUHA, 1980). The basic concepts of electrical volume conduction theory have been used in all these models. Furthermore, special attention has been paid to the sensitivity of the models for specific parameters such as

- parameters that describe source characteristics, e.g. dipole or tripole sources (GRIEP *et al.*, 1978; PLONSEY, 1977; ROSENFALCK, 1969)
- the electrical conductivity of skeletal muscle tissue, e.g. the anisotropy (DIMITROV and DIMITROVA, 1974)
- spatial parameters, e.g. the geometry of the endplate region (GRIEP *et al.*, 1978)
- temporal parameters, e.g. the time synchronisation between single fibre action potentials (BOYD *et al.*, 1978; WANI and GUHA, 1980)
- properties of the measuring method, e.g. uni- or bipolar registration (GRIEP *et al.*, 1978).

In general, it is not yet possible to determine a reliable quantitative relationship between the values of all the relevant parameters, and so a quantitative comparison of measured and computed EMG signals is troublesome. In a

first approach to obtain a quantitative description of the motor unit action potential (MUAP) (GRIEP *et al.*, 1982) it turned out that some parameter values show such a large spread in the literature that no unique quantitative MUAPs could be obtained. An example of such a parameter is the electrical conductivity of skeletal muscle tissue. An overview of literature values was reported by GEDDES and BAKER (1967). Here we only summarise the values obtained with the four-electrode method.

conductivity parallel to the muscle fibres ($= \sigma_L$):

$$0.33 < \sigma_L < 0.80 (\Omega\text{m})^{-1}$$

conductivity transverse to the muscle fibres ($= \sigma_T$):

$$0.04 < \sigma_T < 0.15 (\Omega\text{m})^{-1}$$

anisotropy $\left(= \frac{\sigma_L}{\sigma_T} \right)$ per author:

$$2.04 < \frac{\sigma_L}{\sigma_T} < 15.33$$

To obtain unique and more reliable values for the electrical conductivities we decided to measure the conductivities of the same muscle on which we also carried out our EMG experiments (m. extensor digitorum longus and m. soleus in the hind limb of the rat, *in vivo*). The experiments were carried out with the four-electrode method.

We were interested in electrical conductivities in relation to the interpretation of EMG signals. For this reason the interesting frequency range is associated with the frequency components of EMG signals. This range runs from 10 Hz to about 20 kHz (GATH and STALBERG, 1975; ANDREASSEN and ROSENFALCK, 1978; GRIEP *et al.*, 1982). Our experiments with respect to the determination of electrical conductivities were carried out in a frequency range between 10 Hz and 100 kHz.

First received 21st July and in final form 8th November 1983

© IFMBE: 1984

Our preliminary results from measurements on the EDL showed unexpected results (see Section 4). To interpret these results we developed a model (GIELEN and CRUTS, 1982) which predicted that the results of conductivity measurements depend on the interelectrode distance (IED) in the four-electrode technique. To check this prediction experiments were also carried out on a larger muscle (m. erector spinae in the back of the rabbit). This allowed measurements with a relatively small IED as well as a relatively large IED. This last IED corresponds to IEDs used in experiments reported in the literature.

2 Theory of the measuring method

The usual method for the measurement of the electric conductivity of biological tissues is the four-electrode technique, which eliminates the effects of electrode polarisation (SCHWAN, 1968). The basic principle is shown in Fig. 1.

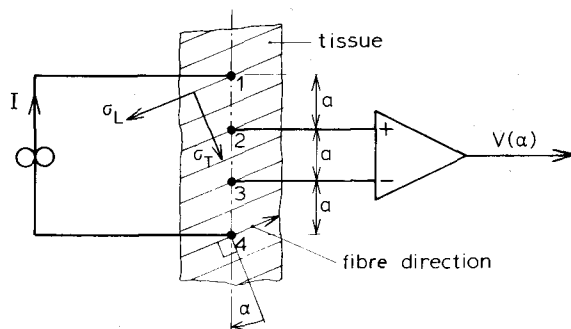

Fig. 1 Schematic representation of the four-electrode method
a = interelectrode distance (IED)

Current is applied to electrode 1 with respect to electrode 4. The ensuing voltage distribution in the tissue is measured by electrodes 2 and 3, which are connected to an amplifier with a high input impedance. For an anisotropic tissue the relationship between the measured voltage and applied current is given by RUSH (1962). It is supposed here that the four electrodes are placed on the surface of the muscle, parallel to the muscle fibres.

$$V(\alpha) = \frac{I}{2\pi a} \frac{1}{\left(\sigma_L \sigma_T \left(\cos^2 \alpha + \frac{\sigma_T}{\sigma_L} \sin^2 \alpha\right)\right)^{1/2}} \quad (1)$$

where

- $\sigma_L; \sigma_T$ = electrical conductivities parallel and transverse to the muscle fibres, respectively
- α = angle between the direction transverse to the muscle fibres and the orientation of the four-electrode array (Fig. 1)
- I = alternating current injected into the tissue
- $V(\alpha)$ = voltage caused by the current I in the tissue
- a = inter electrode distance (Fig. 1).

Eqn. 1 shows that the angle α is an important parameter with regard to the determination of σ_L and σ_T . BURGER and VAN DONGEN (1960), RUSH *et al.* (1963) and GIELEN and BOON (1980) pointed out that for a high anisotropy the results of conductivity measurements are very sensitive to a small misalignment around $\alpha = 90^\circ$.

In general the electrical conductivity in biological tissues can be written as $\sigma = \sigma_0 + j\omega\epsilon$, where σ_0 represents the resistive (= real) and $\omega\epsilon$ the capacitive (= imaginary)

component of the complex electrical conductivity (PLOWSEY and HEPPNER, 1967). Accordingly σ_L and σ_T can be written as:

$$\sigma_L = \sigma_{oL} + j\omega\epsilon_L \quad \text{and} \quad \sigma_T = \sigma_{oT} + j\omega\epsilon_T$$

Eqn. 1 still holds for complex electrical conductivities. In this paper the real and imaginary parts of the conductivity will be presented. In this context the following notation for $V(\alpha)$ and I will be used:

$$V(\alpha) = V(\omega, \alpha) = V_0(\omega, \alpha) \exp[-j(\omega t + \phi(\omega, \alpha))] \quad (2)$$

$$I = I(\omega) = I_0(\omega) \exp[-j\omega t] \quad (3)$$

where

- $V_0(\omega, \alpha)$ = amplitude of $V(\omega, \alpha)$
- $I_0(\omega)$ = amplitude of $I(\omega)$
- $\phi(\omega, \alpha)$ = phase shift between $V(\omega, \alpha)$ and $I(\omega)$
- ω = angular frequency
- t = time
- $j = (-1)^{1/2}$

A combination of eqns 1, 2 and 3 leads to

$$\sigma_T = \frac{I_0(\omega)}{V_0(\omega, 90)} \frac{1}{2\pi a} \exp[j\phi(\omega, 90)] \quad (4)$$

$$\sigma_L = \left\{ \frac{I_0(\omega)}{V_0(\omega, 0)} \right\}^2 \frac{V_0(\omega, 90)}{I_0(\omega)} \frac{1}{2\pi a} \times \exp[j(2\phi(\omega, 0) - \phi(\omega, 90))] \quad (5)$$

Eqns. 4 and 5 were used to determine the real and imaginary parts of σ_T and σ_L .

In the literature it is suggested that the quantities $\omega\epsilon_T/\sigma_{oT}$ and $\omega\epsilon_L/\sigma_{oL}$ are small compared with unity, which means that the tissue is purely resistive. Our experimental results show, however, that skeletal muscle tissue is not purely resistive in the frequency range covered by EMG signals (Section 4).

3 Methods and materials

3.1 Animal and muscle preparation

The experiments were carried out on the EDL and soleus muscle in the right hind limb of the rat, and on the m. erector spinae in the back of the rabbit.

The rats (Wistar; male; 0.3–0.4 kg; 3–8 months old) and the rabbits (Chinchilla and New Zealand-White; 2.5–4 kg) were anaesthetised intraperitoneally with Nembutal (sodium pentobarbitone, Abbott). The first dose for the rabbit was intravenous.

For the rats the muscle was prepared free, but the blood supply was unimpaired. We used soleus and EDL muscle in separate experiments with different rats. For the EDL preparation the n. ischiadicus was cut approximately 3 cm from the muscle. The n. peroneus communis innervating the EDL was isolated from the rest of the n. ischiadicus. For the soleus preparation the n. ischiadicus was also cut approximately 3 cm from the muscle. The n. tibialis innervating the soleus was isolated from the rest of the n. ischiadicus. Then the rat was placed on a heating module ($37 \pm 0.5^\circ\text{C}$) to keep its temperature constant.

Either the EDL or the soleus muscle was attached with the insertio tendon to an isometric force transducer (Harvard Apparatus Inc., model 383). The origo tendon was fixed in a clamp. All experiments were carried out at optimal twitch

length. This ensured a reproducible muscle length for our measurements (WALLINGA-DE JONGE *et al.*, 1980). The twitch was generated by means of a supramaximal stimulation of the nerve to the muscle of interest.

For the rabbits only the surface of the muscle at the periphery of the animal was prepared free. The structure of the tendon and the fixation of the tendon is so complex that we kept it unimpaired; consequently the conditioning of the muscle length was rather inaccurate. This was done by keeping the back of the animal in a straight position during the experiments.

Since the electrical conductivity depends on temperature the temperature of the muscle was controlled by a warm airstream across the muscle. This airstream was at $37 \pm 1^\circ \text{C}$ and saturated with water vapour. The muscle temperature was checked regularly with a small thermistor probe on the surface of the muscle. The conditioning of the muscle surface appeared to be important. Histochemical experiments on slices of the muscles made after finishing the physiological experiments showed a damaged outermost muscle fibre layer. The cross-sections of the fibres were much larger and rounder than normal. We related this effect to an increase of σ_T as observed in some of our experiments, especially at the lower frequencies.

Parallel to this increase the anisotropy decreased down to approximately unity in exceptional cases. To avoid these problems the experiments were carried out as quickly as possible. Furthermore, the final layer of connective tissue was removed just before the start of the measurements. In this context a proper conditioning of the warm airstream is important to avoid condensation of water on the muscle or electrode as well as dehydrating of the muscle surface. Osmotic processes caused by condensation could be the reason for the swelling of the cells as observed in histochemical pictures. These cells showed deviating histochemical characteristics compared with normal cells.

To keep the damage of the small muscles minimal the four-electrode array was placed on the surface of the muscle; but this resulted in a serious problem: a short circuiting of the electrodes by electrolytes on the surface of the muscle. Minimisation of this effect required good conditioning of the muscle surface and its surroundings.

3.2 Experimental procedure

The first measurement was always carried out with the four electrodes placed parallel to the muscle fibres. Using a stereomicroscope it was possible to achieve an accurate positioning. For the electrode with an IED of 0.5 mm it was possible to obtain an orientation within less than 4° from a parallel alignment relative to the fibres visible at the muscle surface. This misalignment was within 2° for an electrode with an IED of 3 mm. A parallel measurement was directly followed by a transverse measurement. A special element of the micromanipulator used to place the four-electrode array on the muscle surface permitted accurate rotation of the electrode. The positions of the four-electrode array in subsequent parallel and transverse measurements were such that the pick-up area of the four-electrode array covered about the same volume of the muscle tissue.

For every frequency, starting with 10 Hz and changed stepwise to 100 kHz, the current amplitude ($I_0(\omega)$), the amplitude of the voltage ($V_0(\omega, \alpha)$) and the phase shift ($\phi(\omega, \alpha)$) were recorded. Usually this procedure was carried out for at least ten parallel and ten transverse positions per muscle and took between 1.5 and 2.5 h. After every pair of parallel and transverse measurements the electrode array was moved over a distance between one and two times the IED along the belly axis of the muscle. In the muscles of

interest this did not coincide with the fibre direction. The position of the electrode array was such that the pick-up area of the four-electrode configuration (ROBBILARD and POUSSART, 1979) was expected to lie completely within the muscle body (Section 3.3.1).

3.3 Experimental setup

The experimental setup is shown in Fig. 2.

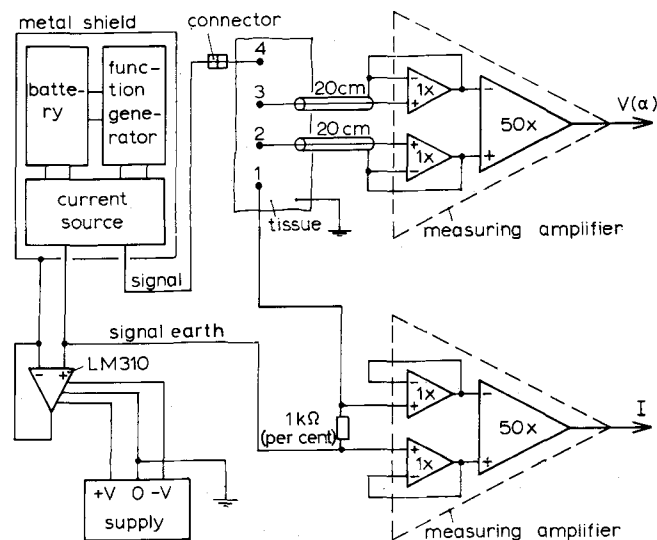

Fig. 2 Schematic representation of the experimental setup. Three main elements can be distinguished: the floating current source, the tissue with the four electrodes and the measuring amplifiers for current and voltage registration

3.3.1 *The electrode.* To minimise possible damage of the muscle we used a surface electrode array. In view of the small dimension of the EDL and the soleus muscle in the rat we chose an IED of 0.5 mm. Theoretically this value corresponds to a sufficiently small pick-up area (ROBBILARD and POUSSART, 1979). We checked this pick-up area experimentally by moving the four-electrode array to the bottom of a relatively large glass vessel containing a saline solution with the lowest conductivity expected in muscle tissue ($0.1(\Omega \text{ m})^{-1}$). It turned out that the measured voltage only changed significantly within a distance of 1.3 mm between vessel bottom and electrode array. This value is significantly smaller than the diameter of rat EDL and soleus muscle (approximately 3 mm).

Eqn. 1 has been derived for point-shaped electrodes and is therefore only valid if the IED ($a = 0.5 \text{ mm}$) is large compared with the electrode diameter ($D = 0.1 \text{ mm}$). For our electrode array ($D/a = 0.2$), eqn. 1 deviated only 2–4 per cent (for an anisotropy $\sigma_l/\sigma_T = 10$) from the exact calculated value for electrodes with a finite area (RUSH, 1962). This deviation was easily corrected for by means of a calibration experiment (Section 3.5).

For electrodes with a small IED (0.5 mm) the electrode material was specially treated iridium (GIELEN and BERGVELD, 1982). For electrodes with a large IED (3 mm; these electrodes were used in rabbit experiments) it was stainless steel. The electrodes were embedded in an epoxy resin except for the tips. They were arranged in such a way that the capacitance between the electrode wires was minimised. The actual capacitance between the electrode wires (this could not be compensated for electronically by bootstrapping techniques) was between 0.06 and 0.6 pF. The DC resistance between the electrodes was larger than 6 GΩ.

To minimise short circuiting by electrolytes at the muscle

surface the ends of the electrode wires (length 1 mm) were not embedded in epoxy resin but only isolated with a thin layer of Isonel (Isonel 31M; AK249). Repeated dipping in liquid Isonel yielded small Isonel bulbs at the electrode tips (bulb diameter approximately 0.3 mm) which were hardened by heating in an oven. After removing the Isonel from the very tips of the electrode wires, which in addition had been point shaped by electrolytic etching, the exposed electrode diameter was near 0.07 mm.

The current electrodes were connected to the current source with single-core wires of 0.25 m length. The voltage-sensing electrodes were connected to the measuring amplifier with bootstrapped shielded cables of 0.2 m length.

3.3.2 The current source. The output of the current source was a sinusoidal current. The frequency was adjustable stepwise between 3 Hz and 100 kHz. This frequency range covered the range of frequency components in EMG signals. The maximum current density at the injecting electrodes caused no direct stimulation of muscle fibres. It is obvious that eqn. 1 only holds if the current I enters and leaves the tissue through electrodes 1 and 4 (Fig. 1). This implies that the current has to be provided by a floating source with no significant leakage (capacitive leakage included) to earth. By means of bootstrapping techniques it was achieved that the battery-powered current source had no significant capacitive and resistive leakage to earth (see Fig. 2 for the schematic setup). The main specifications of the source were:

output impedance: 100 M Ω /15 pF
 output current: 0.1 μ A < $I_0(\omega)$ < 10 μ A
 frequency range: 3 Hz < f < 100 kHz
 harmonic distortion: < 1 per cent.

3.3.3 Measuring amplifier. The measuring amplifier was a special-purpose design, suitable for our experiments. Care was taken to minimise the input capacitance (GIELEN and BERGVELD, 1982). A low input capacitance was achieved using bootstrapping techniques.

The specifications of the amplifier were:

input impedance (including 0.2 m input cable): 200 M Ω /0.3 pF
 bandwidth: DC-130 kHz (-3 dB)
 common mode rejection ratio: > 60 dB (DC-30 kHz).

3.4 Registration procedure

The applied current was also passed through a resistor (Fig. 2). The voltage over this resistor ($V_I(\omega)$) was detected by a measuring amplifier as described in Section 3.3.3.

The voltages $V(\omega, \alpha)$ and $V_I(\omega)$ were displayed on an oscilloscope (HP 1201A) using its monitor function as a Lissajous figure. The RMS values were measured with digital voltmeters (Flucke, 8000 A).

To reduce biological noise and to ensure accurate phase detection $V(\omega, \alpha)$ was passed through a bandpass filter (Krohn-Hite 6400) tuned to the signal frequency. Then the phase shift between $V(\omega, \alpha)$ and $V_I(\omega)$ was measured by means of a phase meter (Krohn-Hite, 3400). It was established that no significant additional phase shift was caused by this procedure.

3.5 Calibration experiments

The measuring equipment was calibrated by conductivity measurements of saline solutions with exactly known electrical conductivities in the same range as expected in skeletal muscle tissue.

The conductivity of a saline solution was measured simultaneously in the same relatively large glass vessel with

our system and with a special-purpose conductivity meter (Radiometer-Copenhagen; type CMM-2f; Celltype CDC 104). It is known that a saline solution is purely resistive in the frequency range involved.

Calibration experiments should therefore be frequency independent and no phase shift should be detected. It turned out that our total system deviated less than 5 per cent from theoretical values in the total frequency range involved and about 1 per cent in the frequency range from 30 Hz to 30 kHz. The phase shift was less than 5° between 10 Hz and 30 kHz. These deviations were constant for a particular conductivity, and changed only slightly as a function of the conductivity of the saline solution. Therefore the calibration experiments resulted in a slightly frequency-dependent calibration factor by means of which the small imperfections in the measuring setup were eliminated. The calibration experiments showed that no electrode polarisation effects occurred. Furthermore, it appeared that the distortion of the current field by the voltage-sensing electrodes caused no serious deviation from the theoretically expected conductivity values (see also Section 3.3.1). Every parallel or transverse measurement was calibrated using calibration factors obtained for a saline conductivity equal to the mean (in the frequency range between 30 Hz and 30 kHz) of the uncalibrated measured conductivities.

The accuracy of the complete experimental system was determined from repeated calibration experiments in a saline solution. It turned out that the complete system permitted the determination of conductivities to within 0.005 (Ω m)⁻¹ and of phase differences to within 0.5° for frequencies higher than 30 Hz. For 10 Hz this was 0.01 (Ω m)⁻¹ and 1° respectively. The actual experimental results from measurements on muscle tissue showed a much larger variation (Section 4, Figs. 3-10).

4 Results

The results reported in this paper were obtained from a series of experiments (eight m. EDL rat, seven m. soleus rat,

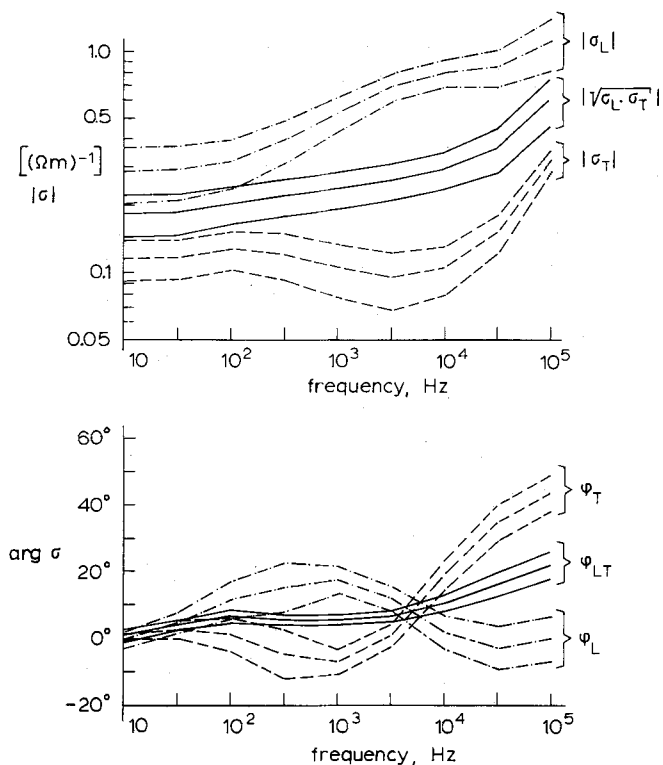

Fig. 3 Mean conductivity values of all measurements of one characteristic experiment
 m. EDL rat, IED = 0.5 mm, N = 10

five m. erector spinae rabbit). In every experiment at least ten parallel and ten transverse sets of measurements were performed at 10, 30, 100, 300, 1000, 3000, 10 000, 30 000 and 100 000 Hz. From calibrated results several quantities could be deduced using eqns. 4 and 5.

The quantities of interest were

- $\sigma_T(f)$ electrical conductivity obtained with the four-electrode array parallel to the muscle fibres
- $(\sigma_L \sigma_T)^{\frac{1}{2}}(f)$ electrical conductivity obtained with the four-electrode array transverse to the muscle fibres

- $\sigma_L(f)$ electrical conductivity parallel to the muscle fibres computed from $\sigma_T(f)$ and $(\sigma_L \sigma_T)^{\frac{1}{2}}(f)$
- $\sigma_L / \sigma_T(f)$ anisotropy in the electrical conductivities
- $\omega \epsilon_T / \sigma_{oT}(f)$ quotient of the imaginary and real parts of $\sigma_T(f)$
- $\omega \epsilon_L / \sigma_{oL}(f)$ quotient of the imaginary and real parts of $\sigma_L(f)$.

All these quantities depend on the frequency, and were analysed (with IED as a parameter)

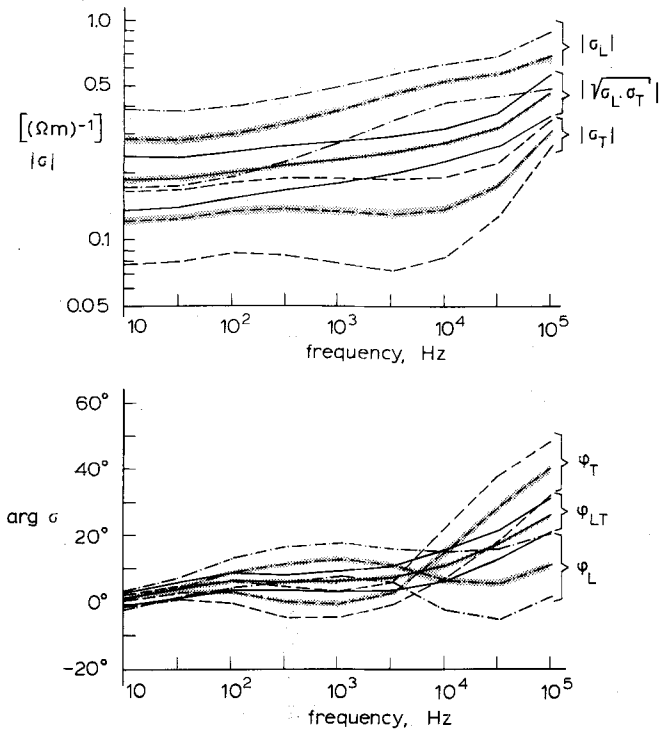

Fig. 4 Mean conductivity values of all measurements of eight experiments
m. EDL rat, IED = 0.5 mm, N = 82

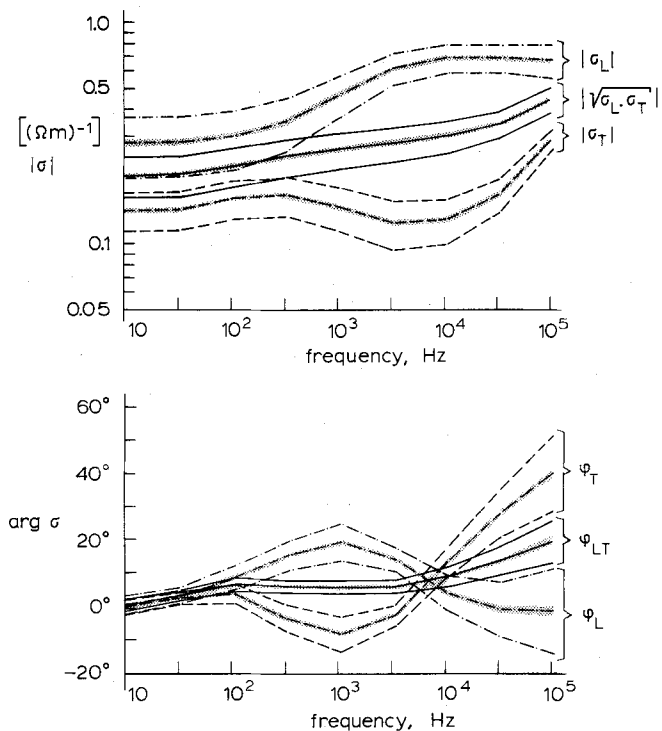

Fig. 6 Mean conductivity values of all measurements of seven experiments
m. soleus rat, IED = 0.5 mm, N = 80

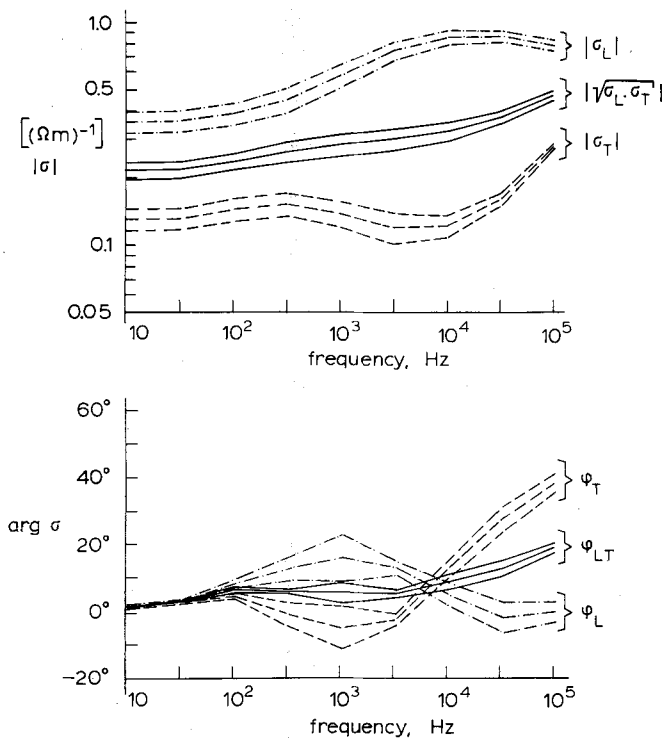

Fig. 5 Mean conductivity values of all measurements of one characteristic experiment.
m. soleus rat, IED = 0.5 mm, N = 10

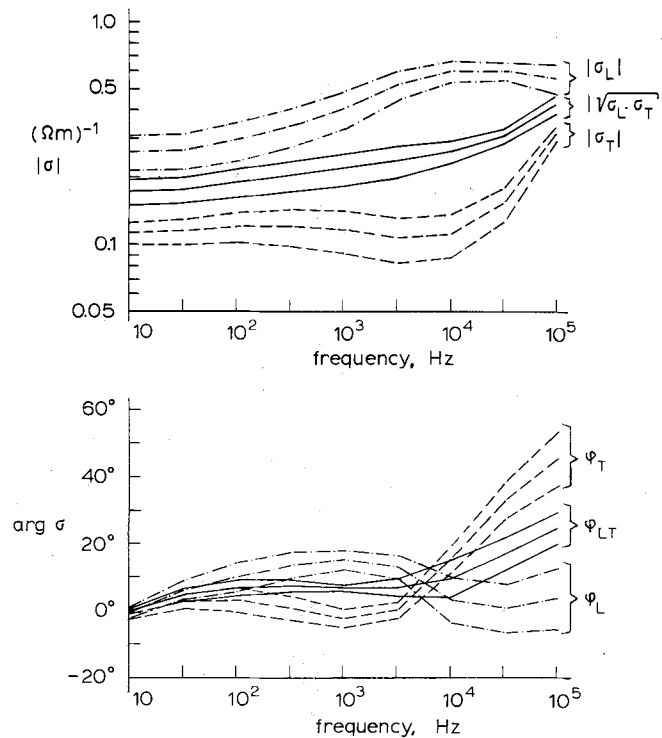

Fig. 7 Mean conductivity values of all measurements of one characteristic experiment
m. erector spinae rabbit, IED = 0.5 mm, N = 11

- (a) per measurement
- (b) as a mean per experiment, indicating the variability in one muscle
- (c) as a mean for all experiments per muscle, indicating the variability in muscles of one type (m. EDL, m. soleus, m. erector spinae).

Because of the lack of objective criteria for omitting extreme data from measurements or experiments, mean values were computed using *all* measurements or experiments.

Mainly based on the course of an experiment and on the relatively small standard deviations belonging to it, we selected examples that we think are 'characteristic results' for the different muscles and IEDs (see Figs. 3, 5, 7, 9a and 9b).

In Figs. 4, 6, 8 and 10 a mean of *all* measurements per muscle per IED is shown.

In all these Figures the horizontal axis in the upper as well as the lower part applies to the frequency in Hz. The vertical axis in the upper part indicates the absolute value of the complex conductivity in $(\Omega m)^{-1}$. The vertical axis in the

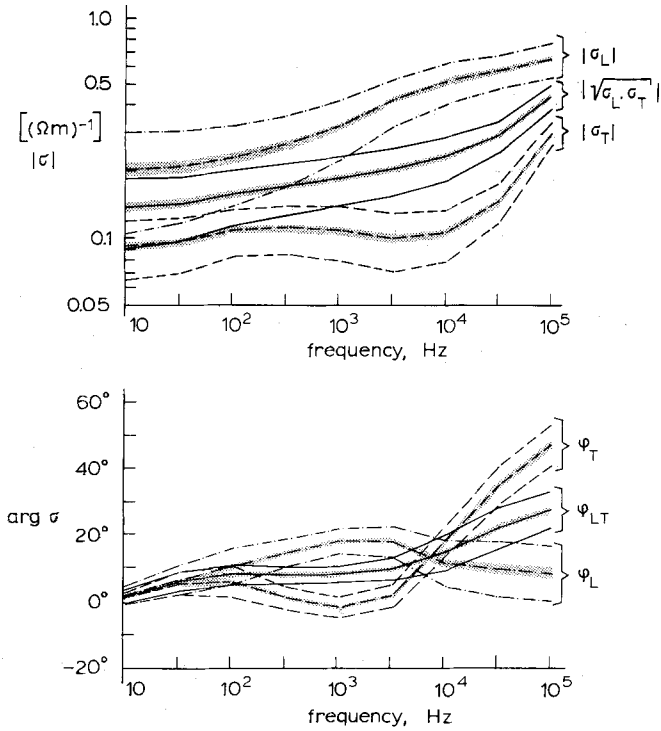

Fig. 8 Mean conductivity values of all measurements of five experiments
m. erector spinae rabbit, IED = 0.5 mm, N = 44

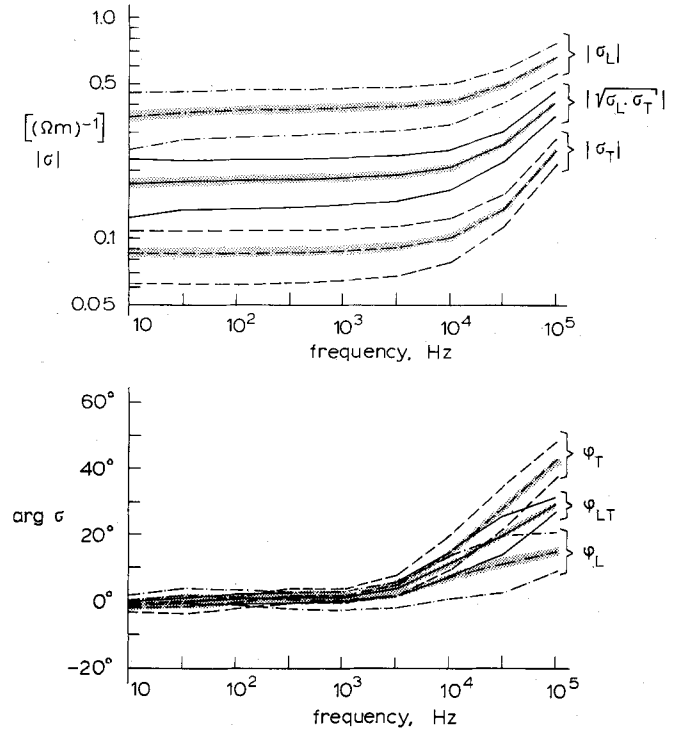

Fig. 10 Mean conductivity values of all measurements of five experiments
m. erector spinae rabbit, IED = 3 mm, N = 27

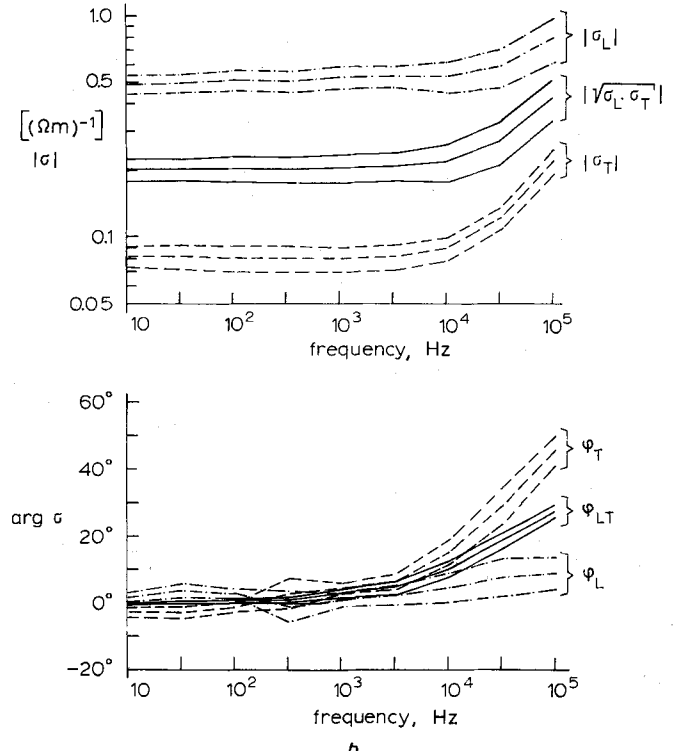
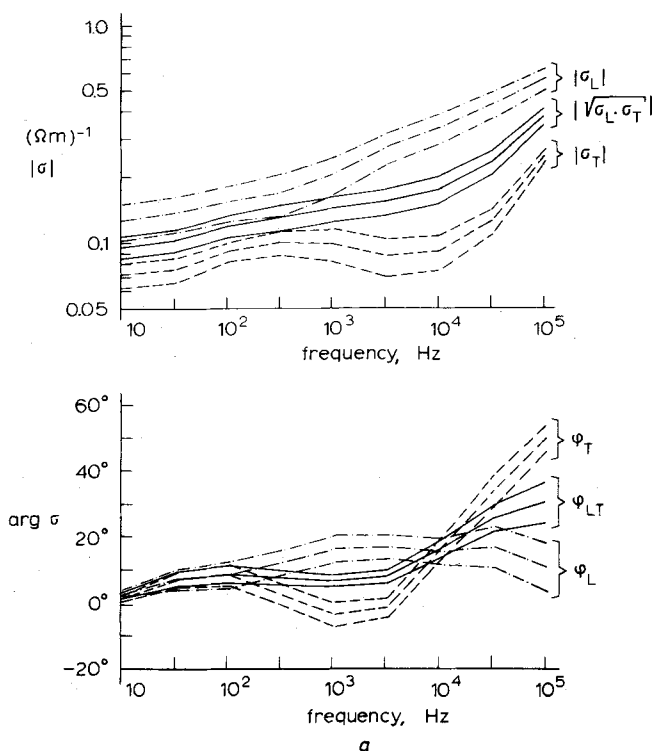

Fig. 9 Mean conductivity values of all measurements of one experiment, *m. erector spinae* rabbit:
(a) IED = 0.5 mm, N = 11,
(b) IED = 3 mm, N = 5

lower part indicates the argument of the complex conductivity (in degrees) (eqns. 4 and 5). In these Figures three sets of curves are given, designated by σ_T or ϕ_T and $(\sigma_T\sigma_L)^{1/2}$ or ϕ_{TL} , respectively, for values obtained with the electrode array parallel and transverse to the muscle fibres. The curves indicated with σ_L or ϕ_L were computed from the former two sets. Every set of curves displays the mean value and the mean value plus or minus the standard deviation. The shaded area represents the standard error of the mean. The number N in the legends of the Figures represents the number of measurements per electrode orientation.

5 Discussion

At first the experimental results will be briefly summarised.

- Conductivities calculated using eqns. 4 and 5 and obtained with an IED of 0.5 mm appeared to be frequency dependent, whereas those obtained with an IED of 3 mm were independent of frequency in the frequency range involved.
- The anisotropy in conductivity (σ_L/σ_T) and permittivity (ϵ_L/ϵ_T) also appeared to be frequency dependent. The value of σ_L/σ_T was somewhat smaller than suggested in the literature.
- The values of $\omega\epsilon_L/\sigma_{oL}$ obtained with an IED of 0.5 mm were not small compared with unity in the frequency range of interest.

5.1 Reliability of the results

As usual for these kinds of measurements our experimental setup was based on the four-electrode technique. VAN OOSTEROM *et al.* (1979) showed that the electrical conductivity of heart muscle changed in ischaemic parts of the heart. Therefore we decided to measure the electrical conductivities *in vivo*.

M. EDL and m. soleus in the hind limb of the rat (*in vivo*) were the subject of investigation in this paper. We also measured the electrical conductivity of the m. erector spinae in the rabbit, which allowed the use of relatively small as well as large IEDs at the same muscle (see also Section 1). The measurements of electrical conductivity in small muscles such as m. EDL and m. soleus caused several specific problems. The pickup area of the four-electrode array (ROBBILARD and POUSSART, 1979) should be, for instance, completely within the muscle belly. Therefore the four-electrode array had a relatively small IED (= 0.5 mm), which caused problems because of stray capacitances in the measuring system (GIELEN and BERGVELD, 1982). Also, the conditioning of the muscle surface was an important factor concerning the reliability and accuracy of the results (Section 3.1). Especially if small IEDs (small pickup area) had to be used, special care was taken to minimise this problem (Section 3.3.1). Histochemical pictures showed that the fibres at the muscle surface were slightly damaged, which we attributed to imperfect conditioning of the muscle surface. This may have caused the change of the values of the measured conductivities in the course of the experiments (Section 3.1). Experiments carried out within 2 h were barely affected (Figs. 4, 6 and 8). The above could have resulted in a small underestimation of the mean anisotropy values (σ_L/σ_T) as shown in Figs. 5, 7 and 9.

5.2 Comparison of our results with literature results

Experimental results obtained with such small IEDs as ours (0.5 mm) have never been reported in the literature for skeletal muscle tissue.

Literature results concerning skeletal muscle tissue as reported in a review by GEDDES and BAKER (1967) and

recently by EPSTEIN and FOSTER (1983); also those for heart muscle tissue (WEIDMANN, 1970; CLERC, 1976; VAN OOSTEROM *et al.*, 1979) are *independent* of frequency between 10 Hz and 5 kHz. However, our results obtained with an IED of 0.5 mm *depend on frequency* not only in that frequency range but also between 5 kHz and 100 kHz, whereas those obtained with an IED of 3 mm are *frequency independent* between 10 Hz and 10 kHz but *frequency dependent* between 10 kHz and 100 kHz (see Section 4). The phase differences correspond to values of $\omega\epsilon_T/\sigma_{oT}$ and $\omega\epsilon_L/\sigma_{oL}$ which are not small compared with unity, as would be the case in a purely resistive tissue. Therefore the assumptions made by PLONSEY and HEPPNER (1967), who assumed the tissue to be purely resistive, are invalid for skeletal muscle tissue.

Except for the dependence on frequencies, our conductivity values are comparable with previously reported values concerning skeletal muscle tissue. Especially, the resemblance between our data obtained with an IED of 3 mm and those recently reported by EPSTEIN and FOSTER (1983) (IED > 10 mm) is fairly good, despite the fact that they did not measure *in vivo*. According to the data of VAN OOSTEROM *et al.* (1979) this results in an underestimation of the values of the conductivities. Although EPSTEIN and FOSTER (1983) used an effectively one-dimensional configuration, whereas we used a three-dimensional one, the electrical conductivities obtained with both methods are the same. This is because the pickup areas of both configurations are large compared with inhomogeneities caused by anatomical structure at a cellular level. Their anisotropy values (σ_L/σ_T) as well as ours are smaller than those reported by BURGER and VAN DONGEN (1960) and RUSH *et al.* (1963), but their values of the dielectric permittivity, both ϵ_T and ϵ_L , show a good agreement with ours.

With respect to the somewhat smaller anisotropy values it is interesting to notice that, despite the apparently reliable and relatively high values of σ_L/σ_T reported by BURGER and VAN DONGEN (1960) and RUSH *et al.* (1963), in EMG models relatively small anisotropy values (~ 5) have always been used.

5.3 Interpretation of the results

Our results were obtained using eqns. 4 and 5, which were based on eqn. 1, deduced by RUSH (1962) for a homogeneous, anisotropic, infinite extended tissue. With regard to the homogeneity of the tissue it is doubtful whether an IED of 0.5 mm is large enough, compared with characteristic distances in skeletal muscle, to satisfy the assumption of homogeneity.

Recently PLONSEY and BARR (1982) proposed a revised theory with respect to the interpretation of results obtained with the four-electrode technique. They showed that for small as well as large IEDs it is correct to use eqn. 1 (cylindrical symmetric conductivities in skeletal muscle tissue), but the conductivities σ_L and σ_T have to be considered as space-averaged electrical conductivities. This interpretation suggests that results will depend on the IED used. The relationship between IED and results obtained with the four-electrode technique has also been discussed in a model proposed by GIELEN (1983).

These models are both based on a redistribution of injected current from initially only extracellular positions to, depending on IED and characteristic electrical distances in the tissue (space constants), extra- as well as intracellular positions. Cell membrane properties appear to be important in this redistribution process.

To study the main effects of this redistribution PLONSEY and BARR (1982) used purely resistive membrane properties. If, however, more realistic membrane properties are used

(FALK and FATT, 1964; WEIDMANN, 1970; MOBLEY and EIDT, 1982) the space constants appear to be frequency dependent (GIELEN, 1983) as contrasted with those given by PLONSEY and BARR (1982). This offers the possibility of measuring the quantities as given by PLONSEY and BARR (1982, eqns. 41 and 46, which are in fact special cases of eqn. 1) using *only one* IED and changing the frequency of the injected current. This is possible due to the frequency-dependent space constant of the tissue. The space constant decreases with increasing frequencies. This is demonstrated theoretically by GIELEN (1983) and experimentally in this paper.

For a tissue with a cylindrical symmetric anisotropy such as skeletal muscle the quantities g_{ix} , g_{iy} , g_{iz} , g_{ox} , g_{oy} and g_{oz} defined by PLONSEY and BARR (1982) can be written as

$$\begin{aligned} g_{ix} &= g_{iL} \\ g_{ox} &= g_{oL} \\ g_{iy} &= g_{iz} = g_{iT} \\ g_{oy} &= g_{oz} = g_{oT} \end{aligned}$$

Here the subscripts *L* and *T* denote parallel and transverse, respectively, to the muscle fibres. Actually, we did not measure the value of $I_0/2\pi SV_L$ corresponding to a large IED (PLONSEY and BARR, 1982, eqn. 46) due to the fact that this

value corresponds to a frequency outside the frequency range tested. To a first approach we assumed this value to be equal to $0.67 (\Omega m)^{-1}$. (This is based on the course of σ_T values at high frequencies as given by EPSTEIN and FOSTER, 1983.)

Making use of this assumption the following values can be derived from Fig. 5 using eqns. 41 and 46 given by PLONSEY and BARR (1982).

$$\begin{aligned} g_{oT} &= 0.134 (\Omega m)^{-1} \\ g_{oL} &= 0.285 (\Omega m)^{-1} \\ g_{iT} &= 0.536 (\Omega m)^{-1} \\ g_{iL} &= 0.447 (\Omega m)^{-1} \end{aligned}$$

It is clear that these values do not agree with the assumption of equal anisotropy ratios as proposed by PLONSEY and BARR (1982).

Finally, it is obvious that our present results cannot be used in a straightforward fashion in electrical volume conduction models such as those mentioned in Section 1. For a correct interpretation of many EMG signals (e.g. single fibre EMG) these results are, however, essential. For this reason it would be of interest to find solution methods for volume conduction problems in which these results can be incorporated.

References

- ANDREASSEN, S. and ROSENFALCK, A. (1978) Recording from a single motor unit during strong effort. *IEEE Trans.*, **BME-25**, 501–508.
- BOYD, D. C., LAWRENCE, P. D. and BRATTY, P. J. A. (1978) On modeling the single motor unit action potential. *Ibid.*, **BME-25**, 236–243.
- BURGER, H. C. and VAN DONGEN, R. (1960) Specific electric resistance of body tissues. *Phys. in Med. & Biol.*, **5**, 431–447.
- CLERC, L. (1976) Directional differences of impulse spread in trabecular muscle from mammalian heart. *J. Physiol.*, **225**, 335–346.
- DIMITROV, G. and DIMITROVA, N. (1974) Extracellular potential field of a single striated muscle fibre immersed in anisotropic volume conductor. *Electromyogr. Clin. Neurophysiol.*, **14**, 423–436.
- EPSTEIN, B. R. and FOSTER, K. R. (1983) Anisotropy in the dielectric properties of skeletal muscle. *Med. & Biol. Eng. & Comput.*, **21**, 51–55.
- FALK, G. and FATT, P. (1964) Linear electrical properties of striated muscle fibres observed with intracellular electrodes. *Proc. R. Soc. London. Ser. B. (Biol. Sci.)*, **160**, 69–123.
- GATH, I. and STALBERG, E. (1975) Frequency and time domain characteristics of single muscle fibre action potentials. *Electroenceph. and Clin. Neurophysiol.*, **39**, 371–376.
- GEDDES, L. A. and BAKER, L. E. (1967) The specific resistance of biological material. A compendium of data for the biomedical engineer and physiologist. *Med. & Biol. Eng.*, **5**, 271–293.
- GIELEN, F. L. H. and BOON, K. L. (1981) Measurements on the (complex) electrical conductivity and the anisotropy in skeletal muscle; a new electrode configuration. Proceedings of the Vth International Conference on Electrical Bio-Impedance, August 1981, Tokyo, Japan, 191–194.
- GIELEN, F. L. H. and BERGVELD, P. (1982) Comparison of electrode impedances of Pt, PtIr (10% Ir) and Ir-AIROF electrodes used in electrophysiological experiments. *Med. & Biol. Eng. & Comput.*, **20**, 77–83.
- GIELEN, F. L. H. and CRUTS, H. E. P. (1982) Anatomical structure and electrical conductivity of skeletal muscle tissue. Proceedings of World Congress on Medical Physics and Biomedical Engineering, Hamburg, 2.28.
- GIELEN, F. L. H. (1983) Electrical conductivity and histological structure of skeletal muscle. Thesis, Twente University of Technology, The Netherlands.
- GRIEP, P. A. M., BOON, K. L. and STEGEMAN, D. F. (1978) A study of the motor unit action potential by means of computer simulation. *Biol. Cybernetics*, **30**, 221–230.
- GRIEP, P. A. M., GIELEN, F. L. H., BOOM, H. B. K., BOON, K. L., HOOGSTRATEN, L. L. W., POOL, C. H. and WALLINGA-DE JONGE, W. (1982) Calculation and registration of the same motor unit action potential. *Electroenceph. & Clin. Neurophysiol.*, **53**, 388–404.
- LORENTE DE NO, R. (1947) A study of nerve physiology. *Studies Rockefeller Inst. Med. Res.*, **132**, 384–477.
- MOBLEY, B. A. and EIDT, G. (1982) Transverse impedance of single frog skeletal muscle fibres. *Biophys. J.*, **40**, 51–59.
- PLONSEY, R. and HEPPNER, D. B. (1967) Considerations of quasi-stationarity in electrophysiological systems. *Bull. Math. Biophys.*, **29**, 657–664.
- PLONSEY, R. (1969) *Bio-electric phenomena*. McGraw-Hill, New York.
- PLONSEY, R. (1977) Action potential sources and their volume conductor fields. *Proc. IEEE*, **65**, 601–611.
- PLONSEY, R. and BARR, R. (1982) The four-electrode resistivity technique as applied to cardiac muscle. *IEEE Trans.*, **BME-29**, 541–546.
- ROBBILARD, P. N. and POUSSART, D. (1979) Spatial resolution of four electrode array. *Ibid.*, **BME-26**, 465–470.
- ROSENFALCK, P. (1969) Intra- and extracellular potential fields of active nerve and muscle fibres. *Acta Physiol. Scand.*, Suppl. 321, 1–168.
- RUSH, S. (1962) Methods of measuring the resistivities of anisotropic conducting media *in situ*. *J. Res. Nat. Bur. Stand.*, **66C**, 217–222.
- RUSH, S., ABILDSKOV, J. A. and MCFEE, R. (1963) Resistivity of body tissues at low frequencies. *Circ. Res.*, **12**, 40–50.
- SCHWAN, H. P. (1968) Electrode polarization impedance and measurements in biological materials. *Ann. NY Acad. Sci.*, **48**, 191–209.
- VAN OOSTEROM, A., DE BOER, R. W. and VAN DAM, R. Th. (1979) Intramural resistivity of cardiac tissue. *Med. & Biol. Eng. & Comput.*, **17**, 337–343.
- WALLINGA-DE JONGE, W., BOOM, H. B. K., BOON, K. L., GRIEP, P. A. M. and LAMMERÉE, G. C. (1980) Force development of fast and slow skeletal muscle at different muscle lengths. *Am. J. Physiol.*, **239**, C98–C104.

WANI, A. M. and GUHA, S. K. (1980) Synthesising of a motor unit potential based on the sequential firing of muscle fibres. *Med. & Biol. Eng. & Comput.*, **18**, 719-726.

WEIDMAN, S. (1970) Electrical constants of trabecular muscle from mammalian heart. *J. Physiol.*, **210**, 1041-1054.

Authors' biographies



Frans L. H. Gielen was born in Emmeloord, The Netherlands in 1951. He received the B.A. degree in Physics (Cryogenics) from Twente University of Technology in 1976, and the M.Sc. degree in Physics (Biophysics) from the same university in 1979. His Ph.D. research was granted by the Dutch Society for Scientific Research (ZWO-Biofysika) and was performed between 1979 and 1983 in the Biomedical Engineering Group of the Department of Electrical Engineering of Twente University of Technology. His special interests are electrophysiology and electric volume conduction theory with respect to EMG signals. He joined Department of Physics & Astronomy of Vanderbilt University, Nashville, Tennessee, USA in February 1984 where his research is on electric and magnetic measurements and models based on electromagnetic theory, which are used for the interpretation of experimental results.



Willemien Wallinga-de Jonge was born in Veendam, The Netherlands in 1945. She received the M.Sc. degree in Biology from the University of Groningen in 1968 and her Ph.D. in Biomedical Engineering from Twente University of Technology, Enschede, in 1980. She is a senior staffmember of the Biomedical Engineering Group, Department of Electrical Engineering of Twente University of Technology. Her research activities there involve the electrical activity of muscle in general and the intracellular and extracellular single fibre activity in particular.

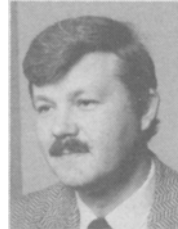

Kasper L. Boon was born in Amsterdam, The Netherlands in 1944. He received an M.Sc. degree in Physics in 1967 from the Technical University of Eindhoven and a Ph.D. in Biomedical Engineering from the Twente University of Technology in 1974. He is a senior staffmember of the Biomedical Engineering Group, Department of Electrical Engineering of the Twente University of Technology. His research activities are mainly directed towards electromyography.