

Newly Designed Occluder Pin for Presacral Hemorrhage

Vito M. Stolfi, M.D., Jeffrey W. Milsom, M.D., I. C. Lavery, M.D.,
John R. Oakley, M.D., James M. Church, M.D., Victor W. Fazio, M.D.

From The Cleveland Clinic Foundation, Cleveland, Ohio

Conventional hemostatic measures are often unsatisfactory in presacral venous bleeding occurring during surgical mobilization of the rectum. We designed a new type of hemorrhage occluder pin, with a ridged shaft, which may be rapidly placed into the sacrum to control hemorrhage. The aims of this study were 1) to assess the best pin shaft length by measuring the thickness of human sacral vertebral bodies, 2) to measure the forces needed to pull the newly designed pin out of the human sacrum compared with conventionally shaped titanium thumbtacks, and 3) to assess clinically the efficacy of the new device. Four fresh cadaveric pelvis were isolated and cut on a sagittal plane, and the thickness of each vertebral body was measured. Titanium pins, both with ridged and with smooth shafts, were used. Twelve-millimeter-shaft pins were used for S1 and S2, and 7-mm pins were used for S3, S4, and S5. Pins were inserted into each sacral vertebra, and the forces needed to extract them from the bone were measured by computerized dynamometry. Significantly more force was required to extract ridged *vs.* smooth pins, both with 12-mm and with 7-mm shafts. There was no significant difference between the forces needed to pull out 12-mm *vs.* 7-mm pins. The new pin was successfully used to stop presacral hemorrhage in three patients with no complications one, three, and six months after surgery. This newly designed hemorrhage occluder pin may represent an improved method of controlling presacral venous hemorrhage. [Key words: Presacral hemorrhage; Occluder pin; Hemostasis]

Stolfi VM, Milsom JW, Lavery IC, Oakley JR, Church JM, Fazio VW. Newly designed occluder pin for presacral hemorrhage. *Dis Colon Rectum* 1992;35:166-169.

The rectum is mobilized from its sacral attachments in the performance of most rectal surgical procedures. In the process, the presacral venous plexus, which lies posterior to the fascia propria of the rectum and just below the presacral fascia, will usually be exposed. Inadvertent entry into the presacral fascia may result in massive bleeding from this venous plexus¹⁻⁴ and from sacral basivertebral veins.² Although this problem is unusual, measures to control it using conventional techniques are often unsatisfactory. In such in-

stances, bleeding may quickly require transfusion, and fatalities have been reported.^{2,5}

Owing to the brief clinical reports of the success of thumbtacks in the management of this important clinical problem,^{2,3} we designed a new type of titanium hemorrhage occluder pin with a ridged shaft (Fig. 1) which may be rapidly placed into the bony substance of the anterior sacrum to control hemorrhage from this area.

The aims of this study were 1) to evaluate the optimum shaft length of an occluder pin which can be safely inserted into the sacral vertebral body without entering the vertebral canal, 2) to measure the forces needed to pull the newly designed, ridged occluder pin out of the human sacrum, compared with conventionally designed titanium thumbtacks, and 3) to evaluate whether this new device is effective in controlling presacral venous bleeding.

MATERIALS AND METHODS

We designed a new hemorrhage occluder pin with a beveled shaft (Fig. 1) which we designated as "ridged." The characteristic of this shaft is the presence of monodirectional beveled grooves which facilitate the insertion while reducing the possibility of the pin being dislodged afterward. As a control, we used conventionally designed thumbtacks made of titanium. The pins were manufactured and generously provided by Surgin, Inc. (Placentia, CA), together with a malleable applicator to hold the pin during insertion (Fig. 2).

Cadaver Study

Four fresh human cadaveric pelvis (two males and two females) were used. The sacrum was isolated and cut in a sagittal medium plane. The thickness of each sacral vertebral body was measured to determine optimal shaft length and avoid entry of the pin into the vertebral canal.

The stability of pins in bone was extrapolated by

Poster presentation at the meeting of The American Society of Colon and Rectal Surgeons, Boston, Massachusetts, May 12 to 17, 1991.

Address reprint requests to Dr. Milsom: Department of Colorectal Surgery, The Cleveland Clinic Foundation, 9500 Euclid Avenue, Cleveland, Ohio 44195-5044.

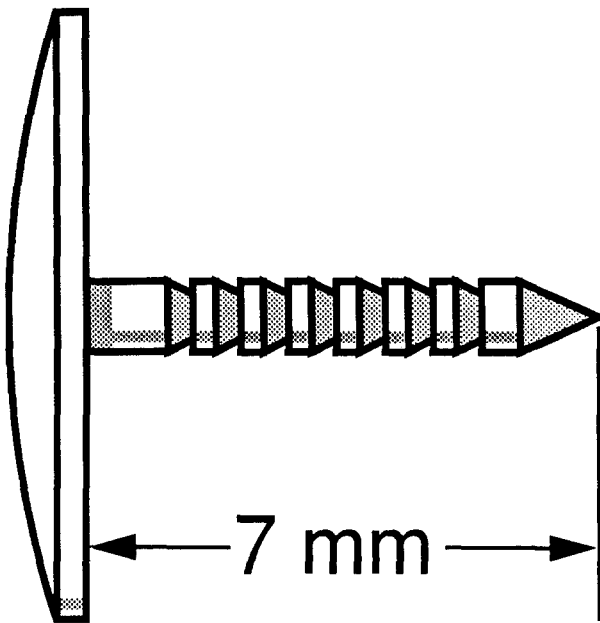

Figure 1. Sketch of the new hemorrhage occluder pin. Its characteristic is the presence on the shaft of circumferential monodirectional beveled grooves which reduce the possibility of the pin being dislodged after insertion.

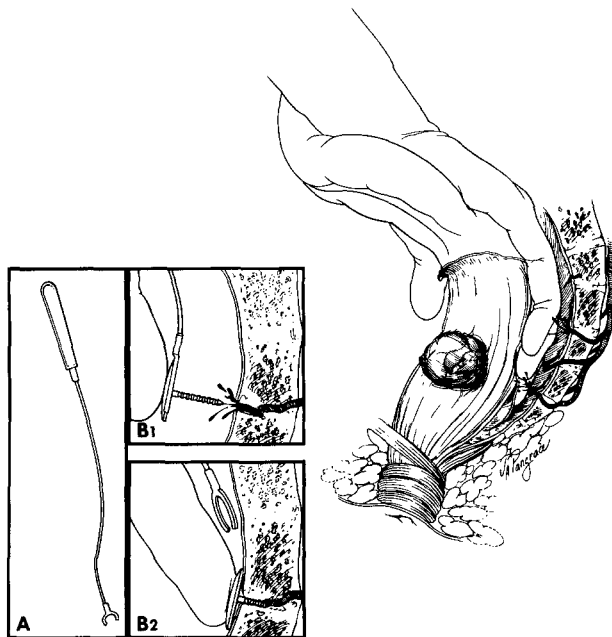

Figure 2. The most likely mechanism of injury to the presacral veins is traction on the veins related to blunt mobilization of the rectum. A. Malleable applicator (11.5 inches) designed to allow precise positioning of the pin in the pelvis. B. Close-up view of pin insertion into the sacrum.

measuring the forces (in newtons) needed to pull out both the ridged and the conventional pin types after insertion into each sacral vertebral body using a computerized dynamometer (858 Bionix Test

System, MTS Systems, Minneapolis, MN). Seven-millimeter pins were tested in all sacral vertebrae; 12-mm pins were tested only in S1 and S2. A trial of 36 pullout measurements was performed for each pin type. Paired data were analyzed by signed rank test. Student's *t*-test was used to determine significance between the ridged and smooth pins in the pullout trials.

Patient Study

Three patients (a 36-year-old female, a 37-year-old female, and a 70-year-old male) developed presacral venous hemorrhage after rectal mobilization for ulcerative colitis (first two patients) and cancer, respectively.

The clinical guidelines used in applying the pins were as follows.

Indications. Pins are applied for control of localized presacral bleeding in patients undergoing surgery when other techniques (cautery and suture) are ineffective.

Surgical Technique. 1) Apply direct fingertip pressure to the bleeding area and note the ability to control bleeding using this technique. 2) If controlled, mount one pin on the malleable applicator, clear surgical fields of blood and clot, and retract adjacent organs for optimal visualization of the presacral area. 3) Rapidly withdraw the hemostatic finger and place the occluder pin directly over the area; seat into the bone so that the head of the pin is flush with the bony cortex. 4) If bleeding continues, consider placement of a second pin if bleeding appears to be emanating from a separate site. Try not to allow overlapping of pin heads.

Contraindications. These include 1) bleeding deemed controllable by direct suture or electrocautery; 2) diffuse hemorrhage from the presacral area, not controllable by fingertip pressure or related to a systemic coagulation disorder; and 3) bleeding greater than 2 cm from the midline or whenever the bleeding point appears to originate from a sacral neural foramen or a vital structure such as the ureter, rectum, or vagina.

RESULTS

The measured thicknesses of the cadaveric sacral vertebral bodies (Table 1) indicate that 7-mm pins could be safely used in all sacral vertebrae. Twelve-millimeter pins could potentially enter the vertebral canal below S2 with injury of the dura mater and subsequent possible meningitis.

The pullout trials ($n = 36$ per pin type), performed by computerized dynamometry, showed that significantly more force was required to extract ridged pins compared with smooth pins either with 12-mm or with 7-mm shafts ($P < 0.01$ in both series) (Table 2). There was no significant difference between the forces needed to pull out 12-

mm- vs. 7-mm-shaft pins of the same design (smooth or ridged) (Table 2).

Finally, the three patients undergoing proctectomy were treated with the newly designed, ridged-shaft pins for presacral venous hemorrhage. The insertion of such pins at the bleeding point achieved immediate hemostasis, and no patient showed any complications or complaints one, three, and six months after surgery. Lateral pelvic radiographs in the patients after these periods of time showed the pins to be intact in the sacrum (Figs. 3A and B).

Table 1.

Sacral Vertebral Body Widths Measured in Four Cadaveric Pelves to Assess the Best Pin Shaft Length to Avoid Entry into the Vertebral Canal

Vertebra	Width (mm)
S1	27 ± 7
S2	18 ± 1
S3	12 ± 1
S4	9 ± 1
S5	8 ± 1

Values are mean ± SE.

Table 2.

Results of the Pullout Trials for 12-mm- and 7-mm-Shaft Pins, Both Ridged and Smooth

Pin Length	Pin Type	Force* (N)
12 mm (n = 36)	Ridged	33 ± 4
	Smooth	13 ± 2
7 mm (n = 36)	Ridged	29 ± 4
	Smooth	12 ± 4

Values are mean ± SE.

n = number of pullout trials.

* Force required to extract pin from bone (N = newtons).

With both shaft lengths, the difference between smooth and ridged was significant ($P < 0.01$). There was no significant difference between the forces needed to pull out a 7-mm pin vs. a 12-mm pin of the same design.

DISCUSSION

The most common cause of presacral hemorrhage is probably related to blunt dissection of the posterior rectal wall from its sacral attachments.²⁻⁴ This complication can be associated with premature breaching of Waldeyer's fascia at the level of the midsacrum, causing denuding of the mid and inferior portions of the sacrum. Tearing of the presacral veins and bleeding may ensue.⁴ A safer method may be sharp dissection in the plane between the fascia propria of the rectum and the presacral fascia. This preserves an intact fascia over the sacrum, leaving the presacral vessels less vulnerable to rupture. The most likely area of injury to these veins is the lower sacrum, where Waldeyer's fascia, running cephalad from the anorectal junction to sacral segments 3 and 4, may be thick and tough and may directly attach to the presacral fascia.⁶

The source of most bleeding in the presacral area is the presacral venous plexus (Fig. 2). This

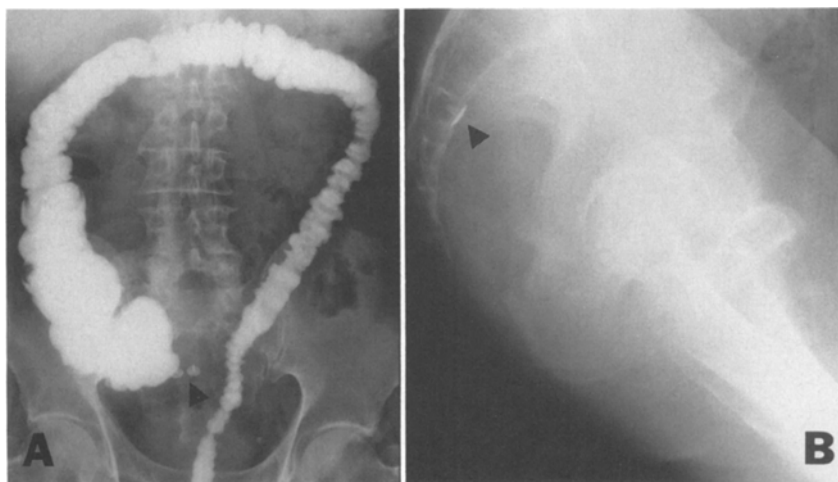

Figure 3. Frontal (A) and lateral (B) x-rays, of a 70-year-old patient in whom two pins were used to stop a presacral hemorrhage, taken three months after the procedure.

plexus is part of the vertebral venous system extending along the entire length of the spine and consisting of external and internal systems, outside and inside the vertebral canal, respectively.^{7,8} The external vertebral system consists of anterior and posterior plexus; the presacral venous plexus is the lowest portion of the anterior external vertebral plexus, and it is generously anastomosed with the internal venous plexus through the basivertebral veins emerging from several large sacral foramina (often 2 to 5 mm in diameter) located usually on the third, fourth, and fifth sacral vertebral bodies.² These veins have no valves, and so the blood flow between these two systems is bidirectional.^{2,9-11} It has been observed that the adventitia of these veins is continuous with and therefore fixed to the sacral periosteum, thereby increasing its propensity to tear, especially when a faulty plane of dissection is struck.² The incidence of major presacral hemorrhage during rectal surgical procedures is rather low, but, when it happens, the hemorrhage may be massive and even fatal.¹⁻⁴ When bleeding is encountered in this region, attempts at ligation, electrocautery, or application of thrombogenic agents are usually futile. Ligation or embolization of the internal iliac arteries is not efficacious in such cases, since the bleeding is venous and the vessels anastomose with the internal vertebral plexus² and the gluteal and obturator veins. The embolization technique may be complicated by perineal and bladder necrosis¹² and paresis.¹³ Pelvic gauze packing is efficacious in achieving and maintaining hemostasis in presacral hemorrhage,⁴ but disadvantages of packing are the need for reoperation and the risk of pelvic sepsis,⁴ coupled with the prolonged hospital stay and wound healing time.

The use of upholstery tacks, briefly described in the literature,^{2,3} appears to be an effective and more practical method of controlling presacral hemorrhage. The new type of ridged occluder pin described in this study is significantly more secure in bone than are conventionally shaped thumbtacks, hopefully reducing any danger of displacement of the pin over time with the potential injury of pelvic organs. The pullout trials showed that 12-mm- and 7-mm-shaft pins are equally secure in bone. For simplicity, we recommended that 7-mm, ridged occluder pins be used in all sacral vertebrae for venous plexus hemorrhage. A malleable pin applicator, currently under development, may allow for more facile pin placement.

In conclusion, owing to the results of the anatomic and dynamic study on cadaveric pelvis and the three clinical cases reported, we believe that the newly designed hemorrhage occluder pin tested in this study may be a rapid, effective, and improved method of controlling presacral hemorrhage.

ACKNOWLEDGMENTS

The authors thank Theodore Wortrich and Armand Maaskamp of Surgin, Inc. (Placentia, CA) for contributing to the design of and for manufacturing the titanium pins used in this study.

REFERENCES

1. Bacon HE, Gutierrez RR. Cancer of the rectum and colon: review of 2,402 personal cases. *Dis Colon Rectum* 1967;10:61-4.
2. Qinyao W, Weijin S, Youreh Z, Wenging Z, Zhengrai H. New concepts in severe presacral hemorrhage during proctectomy. *Arch Surg* 1985;120:1013-20.
3. Nivatvongs S, Fang DT. The use of thumbtacks to stop massive presacral hemorrhage. *Dis Colon Rectum* 1986;29:589-90.
4. Zama N, Fazio VW, Jagelman DG, Lavery IC, Weakley FL, Church JM. Efficacy of pelvic packing in maintaining hemostasis after rectal excision for cancer. *Dis Colon Rectum* 1988;31:923-8.
5. Krause U, Pahlman L, Phoren L. Abdominoperineal excision. *World J Surg* 1982;6:549-53.
6. Crapp AR, Cuthbertson AM. William Waldeyer and the rectosacral fascia. *Surg Gynecol Obstet* 1974;138:252-6.
7. Edwards EA, Malone PD, Macarthur JD. Operative anatomy of abdomen and pelvis. Philadelphia: Lea & Febiger, 1975:73-5.
8. Crock HV, Yoshizawa H. The blood supply of the vertebral column and spinal cord in man. Chicago: RR Donnelly & Sons, 1977:66-9.
9. Norgore M. Clinical anatomy of the vertebral veins. *Surgery* 1945;17:606-11.
10. Gargano FP, Meyer JD, Sheldon JJ. Transfemoral ascending lumbar catheterization of the epidural veins in lumbar disc disease. *Radiology* 1974;111:329-39.
11. O'Dell CW, Cole MN, Ignelzi RJ, *et al.* Ascending lumbar venography in lumbar-disc disease. *J Bone Joint Surg [Am]* 1977;59:159-63.
12. Andriole GL, Sugarbaker PH. Perineal and bladder necrosis following bilateral internal iliac artery ligation: report of a case. *Dis Colon Rectum* 1985;28:183-4.
13. Hare WS, Holland CJ. Paresis following internal iliac artery embolization. *Radiology* 1983;146:47-51.