

IMAGES OF RATE AND OPERATIONAL UNDERSTANDING OF THE
FUNDAMENTAL THEOREM OF CALCULUS[†]

ABSTRACT. Conceptual analyses of Newton's use of the Fundamental Theorem of Calculus and of one 7th-grader's understanding of distance traveled while accelerating suggest that concepts of rate of change and infinitesimal change are central to understanding the Fundamental Theorem. Analyses of a teaching experiment with 19 senior and graduate mathematics students suggest that students' difficulties with the Theorem stem from impoverished concepts of rate of change and from poorly-developed and poorly coordinated images of functional covariation and multiplicatively-constructed quantities.

John Dewey once said that theory is the most practical of all things (Dewey, 1929). Theory is the stuff by which we act with anticipation of our actions outcomes and it is the stuff by which we formulate problems and plan solutions to them. It is in this sense that I consider this theoretical investigation of students' calculus concepts to be a highly practical endeavor. Mine is a theoretical paper driven by practical problems. The theoretical side has to do with imagery and operations in the constitution of students' understanding of the Fundamental Theorem of Calculus; the practical side is motivated by our general lack of insight into the poor quality of calculus learning and teaching in the United States.

A primary theme I will develop is that students' difficulties with the Fundamental Theorem of Calculus can be traced to impoverished images of rate. To develop this theme I will need to make several digressions – one to explicate my use of “image”, one to explain what I mean by images of rate, and a third to clarify issues surrounding the Fundamental Theorem itself.

IMAGERY AND OPERATIONS

By “image” I mean much more than a mental picture. Rather, I mean “image” as the kind of knowledge that enables one to walk into a room full of old friends and expect to know how events will unfold. An image is constituted by coordinated fragments of experience from kinesthesia, proprioception, smell, touch, taste, vision, or hearing. It seems essential also to include the possibility that images entail fragments of past affective experiences, such as fearing, enjoying, or puzzling, and fragments of past cognitive experiences, such as judging, deciding, inferring, or imagining.¹ Images are less well delineated than are schemes of actions or operations (Cobb and von Glasersfeld, 1983). They are more akin to

figural knowledge (Johnson, 1987; Thompson, 1985) and metaphor (Goldenberg, 1988). A person's images can be drawn from many sources, and hence they tend to be highly idiosyncratic.

The roots of this overly-broad characterization of image go back to Piaget's ideas of praxis (goal-directed action), operation, and scheme. I discuss these connections more fully in other papers (Thompson, 1985, 1991, in press a). For the present purpose I will focus on Piaget's idea of an image and its relationship to mental operations.

Piaget distinguished among three general types of images. The distinctions he drew were based on how dependent upon the image were the actions of reasoning associated with it. The earliest images formed by children are an "internalized act of imitation ... the motor response required to bring action to bear on an object ... a *schema* of action" (Piaget, 1967, p. 294). By this I take Piaget to have meant images associated with the creation of objects, whereby we internalize objects by acting upon them. We internalize them by internalizing our actions. Piaget's characterization was originally formulated to account for object permanence. It can also provide insight into a person's creation of mathematical objects (Dubinsky, 1991; Sfard, 1991; Thompson, 1985), and when the development of a person's imagery is halted at this early level it can lead to mathematical understandings that are nothing more than internalized patterns of action (Boyd, 1992).

A later kind of image people create is one having to do with primitive forms of thought experiments. "In place of merely representing the object itself, independently of its transformations, this image expresses a phase or an outcome of the action performed on the object. ... [but] the image cannot keep pace with the actions because, unlike operations, such actions are not coordinated one with the other" (Piaget, 1967, p. 295). It is advantageous to interpret Piaget's description broadly. If by actions we include ascription of meaning or significance, then we can speak of images as contributing to the building of understanding and comprehension, and we can speak of understandings-in-the-making as contributing to ever more stable images.

A third kind of image people come to form is one that supports thought experiments, and supports reasoning by way of quantitative relationships. An image conjured at a moment is shaped by the mental operations one performs, and operations applied within the image are tested for consistency with the scheme of which the operation is part. At the same time that the image is shaped by the operations, the operations are constrained by the image, for the image contains vestiges of having operated, and hence results of operating must be consistent with the transformations of the image if one is to avoid becoming confused.²

[This is an image] that is dynamic and mobile in character ... entirely concerned with the transformations of the object. ... [The image] is no longer a necessary aid to thought, for the actions which it represents are henceforth independent of their physical realization and consist only of transformations grouped in free, transitive and reversible combination... In short, the image is now no more than a symbol of an operation, an imitative symbol like its precursors, but one which is constantly outpaced by the dynamics of the transformations. Its sole function is now to express certain momentary states occurring in the course of such transformations by way of references or symbolic allusions." (Piaget, 1967, p. 296.)

Piaget's ideas of image are similar to those of Kosslyn (1980), and Johnson (1987), but in different degrees. Kosslyn dismisses the idea of images as mental pictures (Kosslyn, 1980, p. 19), characterizing images as highly processed perceptual data that only resembles what is produced during actual perception. On the other hand, Kosslyn's is a correspondence theory, whereby images *represent* features of an objective reality. Piaget's theory assumes no correspondence; it takes objects as things constructed, not as things to be represented (von Glasersfeld, 1978). Also, Kosslyn's notion of image seems to be much more oriented to visualization than is Piaget's. Piaget was much more concerned with ensembles of action by which people assimilate objects than with visualizing an object in its absence. Finally, Kosslyn focuses on images as the PRODUCTS of acting. Piaget focuses on images as the products of ACTING. So, to Kosslyn, images are data produced by perceptual processing. To Piaget, images are residues of coordinated actions, performed within a context with an intention, and only early images are concerned with physical objects.

Piaget's idea of image is remarkably consistent with Johnson's (1987) detailed argument that rationality arises from and is conditioned by the patterns of our bodily experience. Johnson takes to task realist philosophy and cognitive science (which together he calls "Objectivism") in his criticism of their attempts to capture meaning and understanding within a referential framework.³

Piaget maintained throughout his career that all knowledge originates in action, both bodily and imaginative (Piaget, 1950, 1968, 1971, 1976, 1980). While Johnson's primary purpose was to give substance to this idea in the realms of everyday life, Piaget was primarily concerned with the origins of scientific and mathematical reasoning – reasoning that is oriented to our understandings of quantity and structure. For example, while Johnson focused on the idea of balance as an image schema emerging from senses of stability and their projection to images of symmetric forces (Johnson, 1987, pp. 72–98), it requires a nontrivial reconstruction to create an image of balance as involving countervailing twisting actions – where we imagine the twisting actions themselves in such a way that it occurs to us that we might somehow measure them. It seems to involve more than a metaphorical projection of balance as countervailing pushes to have an image of balance that entails the understanding that any of a class of weight-distance pairs on one side of a fulcrum can be balanced by any of a well-determined class of weight-distance pairs on the other side of a fulcrum.

I should note that the meaning of "image" developed here is only tangentially related to the idea of concept image as developed by Vinner (Tall and Vinner, 1981, Vinner, 1987, 1989, 1991, 1992, Vinner and Dreyfus, 1989). Vinner's idea of concept image focuses on the coalescence of mental pictures into categories corresponding to conventional mathematical vocabulary, while the notion of image I've attempted to develop focuses on the dynamics of mental operations. The two notions of image are not inconsistent, they merely have a different focus.

The construct of image portrayed here – as dynamic, originating in bodily actions and movements of attention, and as the source and carrier of mental operations – will be fundamental to analyses of students understanding of integral

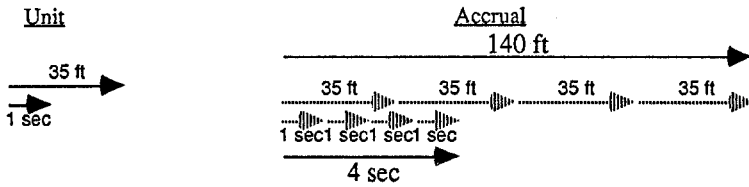

Distance and time accrue simultaneously and in proportional correspondence. One speed-distance or part thereof is made while moving for 1 time-unit or corresponding part thereof. Moving for one time-unit or part thereof implies moving one speed-distance or corresponding part thereof.

Distance and time accrued simultaneously and continuously. Each speed-distance is a fractional part of the total accrued distance. Each time-unit is a fractional part of the total accrued time.

Fig. 1. Speed as a rate. Distance and time accrue simultaneously and continuously, and accruals of quantities stand in the same proportional relationship with their respective total accumulations. This image supports proportional correspondence, that $\frac{a}{b}$ ths of one accumulation corresponds to $\frac{a}{b}$ ths of the other accumulation.

and derivative. It will provide the orientation needed to speculate about what the “something” is that students have in mind when they speak of something changing or of something accumulating.

IMAGES OF RATE

The development of images of rate starts with children’s image of change in some quantity (e.g., displacement of position, increase in volume), progresses to a loosely coordinated image of two quantities (e.g., displacement of position and duration of displacement), which progresses to an image of the covariation of two quantities so that their measures remain in constant ratio (Thompson, in press a; Thompson and Thompson, 1992).

The development of mature images of rate involves a schematic coordination of relationships among accumulations of two quantities and accruals by which the accumulations are constructed. For example, in the case of constant speed, the total distance traveled in relation to the duration of the trip can be imagined as each having accumulated through accruals of distance and accruals of time so that at any moment during the trip the total distance traveled at that moment in relation to the total time of the trip is the same as the accrual of distance in relation to the accrual of time (Figure 1).

Rates which involve time seem to be the most intuitive, but time as a quantity which can be imagined to vary proportionally with another quantity is a non-trivial construction for students (Thompson and Thompson, in press; Thompson, in press a). A further abstraction is required to develop an image of rate that entails the covariation of two non-temporal quantities (e.g., volume and surface area) and the notion of average rate of change of some quantity over some range of an independent quantity (e.g., average rate of change of luminance with respect to the displacement of a light source from 9.2 meters to 9.5 meters away from a target, which might be measured in (candela/cm²)/meter).

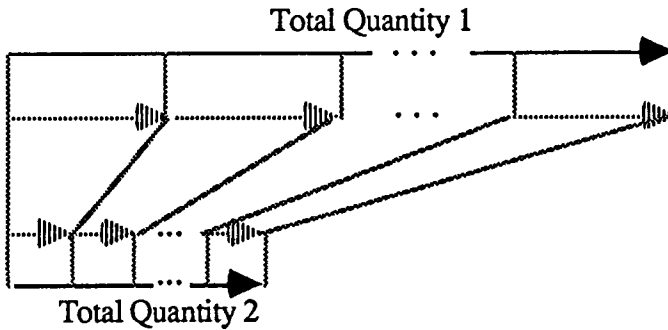

Fig. 2. An image of rate that entails proportionality between total accumulations in relation to accumulations of accruals. The two quantities vary in relation to each other so that the fractional part of Total Quantity 1 made by any accumulation of accruals or parts thereof within Total Quantity 1 is the same as the fractional part of Total Quantity 2 made by a corresponding accumulation of accruals or parts thereof within Total Quantity 2.

A general scheme for rate entails coordinated images of respective accumulations of accruals in relation to total accumulations. The coordination is such that the student comes to possess a preunderstanding that the fractional part of any accumulation of accruals of one quantity in relation to its total accumulation is the same as the fractional part of its covariant’s accumulation of accruals in relation to its total accumulation. More formally, this can be expressed as

$$\frac{\text{accumulated accruals 1}}{\text{total accumulation 1}} = \frac{\text{accumulated accruals 2}}{\text{total accumulation 2}}$$

although expressing it this way does not capture the dynamics of an image of covariation that I am trying to convey. I have tried to capture this image of covariation in constant ratio in Figure 2. Another way to interpret the diagram in Figure 2 is that it is the product of one’s coordination of iterable units (Steffe, 1991 and in press).

A significant aspect of mature images of rate is that accruals and accumulations are two sides of a coin. Two quantities which change in measure (accumulate) so that they remain in constant ratio do so through simultaneous accruals which adhere to the ratio; two quantities which change through accruals in constant ratio have total accumulations which themselves adhere to the ratio. A hallmark of a mature image of rate is that accrual necessarily implies accumulation and accumulation necessarily implies accrual.⁴

THE FUNDAMENTAL THEOREM OF CALCULUS

The Fundamental Theorem of Calculus, developed independently by Newton and Leibniz in the late 1600’s, provides what Courant called “the root idea of the whole of differential and integral calculus” (Courant, 1937, p. 111). Its creation made possible the algorithmic development of what we know now as

the calculus. It also created a cultural necessity for deeper examinations of, and ultimately the resolution of, relationships between conceptions of discrete and continuous magnitudes, whence the formalization of the real number system (Baron, 1969; Boyer, 1959; Wilder, 1981). While the history of the Fundamental Theorem and the developments it fostered are rich and fascinating as topics in their own right, I will focus on ways of thinking that might make it intelligible to individuals reflecting on relationships between derivative and integral. The relationship between derivative and integral is often stated today as follows:

FUNDAMENTAL THEOREM OF CALCULUS

Suppose f is continuous on a closed interval $[a, b]$.

Part I. If the function G is defined by

$$G(x) = \int_a^x f(t)dt$$

for every x in $[a, b]$, then G is an antiderivative of f on $[a, b]$.

Part II. If F is any antiderivative of f on $[a, b]$, then

$$\int_a^b f(x)dx = F(b) - F(a)$$

(Swokowski, 1991, p. 283)

I shall focus on what Swokowski calls *Part I* of the Fundamental Theorem. This says that if some quantity A has a measure t that ranges from a to b , and if some quantity B has a measure $f(t)$ that is conceived as being a function of the measure of A , and if AB is a quantity made multiplicatively from quantities A and B , then as quantity AB accumulates with variations of A (and hence B), the accumulation of quantity AB changes at a rate that is identical with the measure of quantity B at the upper end of AB 's accumulation.⁵

The Fundamental Theorem of Calculus – the realization that the accumulation of a quantity and the rate of change of its accumulation are tightly related – is one of the intellectual hallmarks in the development of the calculus. Prior to Newton's and Leibniz' realization of the Fundamental Theorem, what we now call integration was conceived primarily as the determination of a cumulative amount of some quantity, such as arc length, area, volume, or mass; what we now call differentiation was conceived primarily as the determination of angular velocity, tangency, and curvature (Baron, 1969). But these two classes of problems were conceived separately, and each was developed with techniques limited to the type of problem being addressed.

Although both classes of problems are readily seen to be separately capable of inversion, thus, given the area under the curve or the tangent to the curve in terms of abscissa or ordinate, to find the curve, the relation between tangent method and quadrature [area] is not so immediately obvious. The relation between tangent and arc ultimately became one of the most significant links between differential and integral processes and, for this and other reasons, the problem of rectification became crucial in the seventeenth century. The inverse nature of the two classes of

problems was approached in terms of a geometric model by Torricelli, Gregory and Barrow but only with Newton did the relation emerge as central and general. (Baron, 1969, p. 4)

The focus on the two classes of problems mentioned by Baron developed as a natural outgrowth of the realization by Apollonius, Oresme, Viète, Descartes, and Fermat that covariation of two magnitudes can be depicted graphically, so that any problem having to do with accumulation could be represented as the determination of an area and that any problem having to do with rate of change could be represented as the determination of tangency (Boyer, 1959). That is, initial development of ideas of the calculus was being done by mathematicians who had a strong preunderstanding that even though they were focusing explicitly on tangents to curves or areas bounded by curves, they were in fact looking for general solutions to any problem of accumulation or change that could be expressed analytically.

Accounts by Baron (1969) and by Boyer (1959) suggest that Newton became aware of the Fundamental Theorem by way of a very definite image of cumulative variation: that accumulations happen by a process of accrual.⁶

Here [in Newton's development of relationships between derivative and integral] we have an expression for area which was arrived at, not through the determination of the sum of infinitesimal areas, nor through equivalent methods which had been employed by Newton's predecessors from Antiphon to Pascal. Instead, it was obtained by a consideration of the momentary increase in the area at the point in question. In other words, whereas previous quadratures had been found by means of the equivalent of the definite integral defined as a limit of a sum, Newton here determined first the rate of change of the area, and then from this found the area itself by what we should now call the indefinite integral [antiderivative] of the function representing the ordinate. It is to be noted, furthermore, that the process which is made fundamental in this proposition is the determination of rates of change. In other words, what we should now call the derivative is taken as the basic idea and the integral is defined in terms of this. (Boyer, 1959, p. 191)

It is worthwhile to mention that Newton envisioned fluxions (rates of change in quantities) and fluents (flowing quantities made by fluxions) as what we would today call functions. This is one reason why his insight was so important. His method was to start with an analytic expression for a function f that gives the rate of change of some quantity and derive an analytic expression for a function F that gives the cumulative amount of that quantity.

What images might have supported Newton's insight? First, Newton was committed to an image of dynamic quantities, in continual flux, instead of to the more common notion of quantities in fixed, indeterminate states (Kaput, in press). Second, as noted by Baron (1969, pp. 263–266), Newton understood motion as being the unifying concept for his methods to determine tangency (rate of change), curvature, arc length, and quadrature (accumulation). Third, he felt quite comfortable thinking of a continuum as being composed of infinitesimals – quantities as small as one pleases which may be discounted when held in comparison to a quantity which is an order of magnitude larger (Boyer, 1959, pp. 198–200).⁷

Here is one way to take these notions in combination so that the Fundamental Theorem is intuitively clear: In a changing, multiplicative quantity, the total accumulation changes at the rate of the accruals of the constitutive quantities.

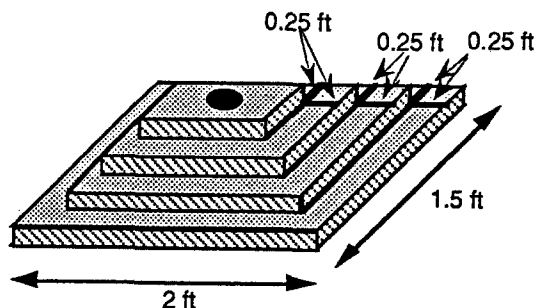

Fig. 3. A mold made of tiers with square bases. Each corner of a tier is offset 0.25 ft perpendicularly from the nearest edge of the tier below it.

For example, suppose you have driven a car for x miles, and that in the next 0.0001 seconds you average 93 km/hr. During that 0.0001 seconds, your *total* driving distance is changing at the rate of 93 km/hr – regardless of how far you have driven. If we imagine that during each infinitesimal period of time you drove at some average speed, and if we could know each of those average speeds, we could reconstruct your total driving distance at each infinitesimal moment of time. Thus, if we were to have an analytic expression which gave us your speed during each infinitesimal period of time, we could, in principle, recover your “distance function.” The problem is now one of technique – construct an analytic function whose rate of change differs at most infinitesimally from the rates of change we know you had. This method is not unique to speed and distance, but will apply to any quantity constructed multiplicatively from a rate and another quantity.

A second example will highlight the interrelationships among accumulation of a quantity, accruals in its constituents, and rate of change: Suppose that liquified plastic is being poured into a hollow mold, shown in Figure 3, through a hole in its top. Each corner of a tier is offset 0.25 feet perpendicularly from the nearest edges of the tier below it. Let $v(h)$ represent the volume of plastic in the mold as a function of the plastic’s height h from the bottom of the mold. At what rate is $v(h)$ changing with respect to h when the plastic is filling the third tier? The *total* volume is changing at the average rate that the third tier is filling, which is simply the volume of the tier divided by the height of the tier, which in turn is $(A(\text{base}) \cdot \text{height})/\text{height}$.

These examples bring out two important images: (1) thinking of quantities as being composed multiplicatively of two other quantities, and (2) thinking in terms of infinitesimals.⁸ In the first example, increments of distance are conceived of being made by traveling for some small amount of time at some speed. In the second example, increments of volume are conceived as being made by taking some base area to a varying height. In either case, the accumulating quantity is imagined to be made of infinitesimal accruals in the quantities which, composed multiplicatively, make up the accruals in the accumulating quantity. When one

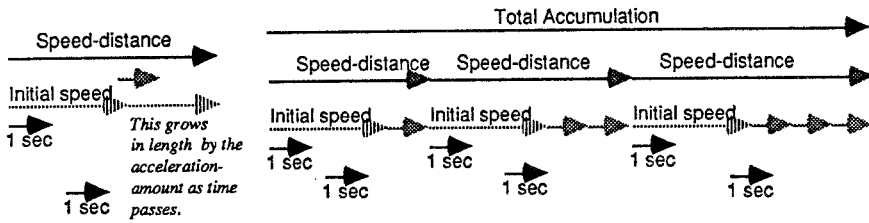

Fig. 4. Acceleration – the rate at which the speed-distance per time-unit grows. Image is of acceleration happening in jumps.

of those quantities is the rate at which the quantity changes over an infinitesimal interval, then the total accumulation changes over any infinitesimal interval at the quantity’s rate of change over that infinitesimal interval.

EARLY IMAGES OF THE FUNDAMENTAL THEOREM OF CALCULUS

While we cannot expect students to recreate the discoveries of Newton, we can look for kinds of reasoning which would provide us with starting points to develop instructional and curricular approaches oriented at students’ development of imagery and forms of expression to support their later insight into important ideas in the calculus. In this section I will report one teaching experiment which attempted to do this. The teaching experiment was with Sue, a seventh-grader, and the content of the teaching experiment were the ideas of speed and acceleration.

An image of acceleration is that “speed grows with time.” I have depicted this image in Figure 4. The quantification of acceleration is the determination of by how much the speed-distance grows with each passing unit of time. The complication that acceleration introduces in students’ comprehension of situations is not so much in the accrual as in imagining the accumulation.

I depicted the accumulation in Figure 4 as happening only in whole-increments of time. This depiction seems justified not as an accurate portrayal of the most sophisticated understanding of acceleration, but as an intermediate image that becomes refined through the study of limiting processes typically developed in calculus.

Sue’s work on a problem having to do with acceleration is presented below. I had already established that Sue possessed the scheme of operations entailed in Figure 2 in the context of a unit on reasoning about speed as a rate (Thompson, in press a).

EXCERPT 1

- 1.1 Pat: Imagine this. I’m driving my car at 50 mi/hr. I speed up smoothly to 60 mi/hr, and it takes me one hour to do it. About how far did I go in that hour?
- 1.2 Sue: *(Long pause. Begins drawing a number line.)*
- 1.3 Pat: What are you doing?

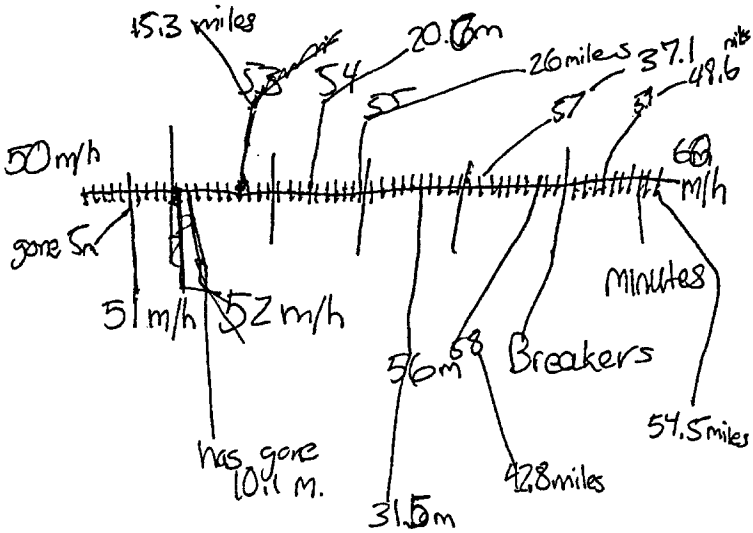

approx. 54.5 miles in that hour

$\frac{150 \text{ m/h}}{6 \text{ min}} = 51$

Fig. 5. Sue's scratch work for "How far did I go while I took one hour to speed up from 50 mi/hr to 60 mi/hr?" .

- 1.4 Sue: I figure that if you speed up 10 miles per hour in one hour, that you speeded up 1 mile per hour every 6 minutes. So I'll figure how far you went in each of those six minutes and then add them up. (See Figure 5.)
- 1.5 Pat: (After Sue is finished.) Is this the exact distance I traveled?
- 1.6 Sue: No ... you actually traveled a little farther.
- 1.7 Pat: How could you get a more accurate estimate?
- 1.8 Sue: (Pause.) I could see how far you went every time you speed up a half mile per hour.

Figure 5 shows Sue's work. She assumed that Pat accelerated at the rate of 10 (mi/hr)/hr, which would be equivalent to $1 \text{ (mi/hr)/}\frac{1}{10} \text{ hr}$. She then assumed Pat drove for one-tenth of an hour (6 minutes) at 50 mi/hr, then one-tenth hour at 51 mi/hr, and so on. She then determined how far Pat would go in each of these one-tenth hour periods.

Sue's solution to estimating the distance I traveled while accelerating has the

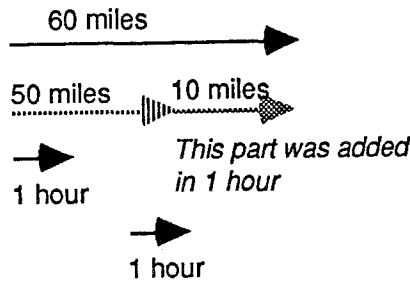

Fig. 6. Sue’s image of increasing a car’s speed from 50 miles per hour to 60 miles per hour as being the result of increasing the speed-distance by 10 miles at a uniform rate of 1 mile every one-tenth of an hour.

structure of a Riemann sum. It would be expressed formally as

$$\Delta V = \text{final speed} - \text{initial speed} \quad (\text{a number of miles per hour})$$

$$\Delta T = \text{final time} - \text{initial time} \quad (\text{a number of hours})$$

$$\Delta t = \frac{\Delta T}{\Delta V} \quad (\text{a number of hours})^9$$

$$\Delta v = 1 \text{ mi/hr}$$

$$d = \sum_{i=0}^{n-1} (\text{initial speed} + i\Delta v)\Delta t \quad (\text{a number of miles}),$$

which says that you first imagine that the increase in speed is distributed evenly across the number of hours you take to speed up, then pretend that you go at a constant speed within each increment of time and add up how far you go in each of them.

What I wish to draw attention to is Sue’s initial inference that Pat’s speed increased by one mile per hour every one-tenth of an hour. This seems to be the crucial inference that got her going, and this inference seems to be based on an image of total acceleration like that shown in Figure 6.

Sue’s inference was that since 10 mi/hr was added to Pat’s speed in one hour, this was the same as adding 1 mile per hour to Pat’s speed every one-tenth of an hour.¹⁰ This suggests an image of acceleration that falls between a concept of speed and a concept of continuously accelerated speed.

While we can be inspired by the sophistication of Sue’s reasoning, we should take care not to read too much into it. Evidently, Sue had an operational rate scheme, as evidenced by her coordination of acceleration, velocity, and distance, but she had not yet formalized these coordinations so that she could express them analytically. In Excerpt 1, Sue’s construction of distance traveled while accelerating for one hour was for a specific increase in speed over a specific amount of time. She was not able to express the general structure of her approach as I did in my summary after Figure 5. To accomplish such a summary, Sue would

have needed to encapsulate her method within a language so that her entire process is captured by an expression which describes local behavior of the process.

Another aspect of Sue's reasoning which will be important in the sequel is that her image of the situation seemed not to entail the continuous growth of velocity, and hence of distance, *during* the periods of acceleration. She did not realize that the questions I asked her could have been asked about *any* moment of time during the two respective periods of acceleration, and that her calculational method would, in principle, yield an approximate distance traveled at *each* moment while accelerating. This is not to disparage Sue's reasoning. Rather, it is to point out a significant difference between Newton's and Sue's perspectives. Sue saw completed growth. Newton saw cumulative growth varying immediately as a function of time.

The inspiration we can draw from Sue's example is that there are early forms of imagery which we might draw upon pedagogically in teaching ideas of the calculus. It remains an open question as to how we might provide occasions for students to transform those images into others which are propitious for insight into the calculus.

A TEACHING EXPERIMENT ON THE FUNDAMENTAL THEOREM OF CALCULUS

To study students' insights into the Fundamental Theorem of Calculus I devised a teaching experiment for a group of students enrolled in a course on computers in teaching mathematics. I had two reasons for choosing this group of students. The first was serendipity – this course is structured to have students first experience what it means to conceptualize important ideas in mathematics deeply and then devise instruction to foster the same experiences with their students. A focus on the Fundamental Theorem fits naturally within this structure. The second reason is that I hoped to gain insight into the kinds of understandings and orientations students take with them from introductory calculus and into secondary mathematics classrooms.

The Students

The group was composed of 7 senior mathematics majors, 1 senior elementary education major, 10 masters students in secondary mathematics education, and 1 masters student in applied mathematics. Seventeen students had completed 3 semesters of calculus with grades of B or better, while the other two had grades of C. Seven students had taken advanced calculus and four were currently enrolled in advanced calculus.

In a preliminary assessment only one student, a teacher of Advanced Placement calculus, gave a satisfactory definition of the definite integral of a function; the expression $x^{n+1}/(n+1)$ was the most common response. Only four students gave a satisfactory definition of the derivative of a function; statements about the slope of a tangent were the most common response. In response to the question

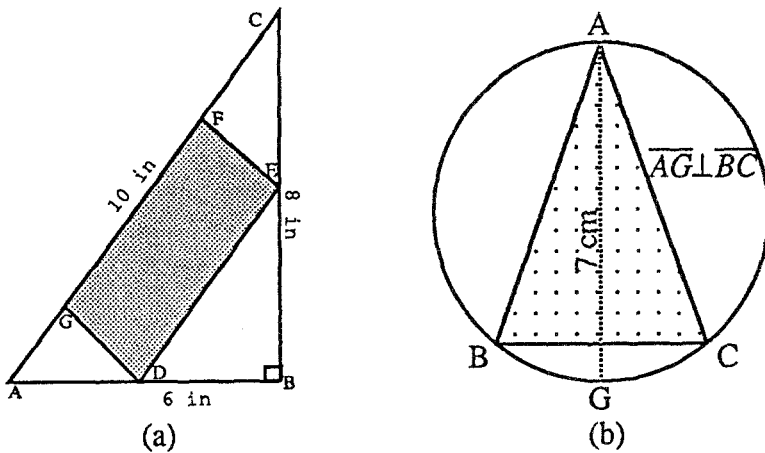

Fig. 7. Diagrams accompanying this problem: Use a graphing program to find the dimensions of the rectangle in (a) and the triangle in (b) which produce the largest possible area.

“What letter goes in the blank to define this function: $F(_) = \int_a^x f(t)dt$,” 16 students said that the letter t goes in place of the blank. Fifteen of 19 students solved a simple optimization problem, and 10 of 19 solved a complex optimization problem. Both optimization problems were taken from a calculus text.

The concept of function was problematic for many students. Six of 19 students could express the area of the rectangle in Figure 7a or the area of the triangle in Figure 7b as a function of some quantity (e.g., area of the rectangle as a function of the length of \overline{AD} in Figure 7a) so that it could be graphed over a suitable domain by a graphing program. A common complaint was that there was not enough information to “solve for the area.” Four of 19 students gave satisfactory explanations for why the graph of $f(x) = \cos(8 \sin(3x))$, $x \in [-\pi, \pi]$, behaves as it does. Most explanations made no reference to the behavior of $8 \sin(3x)$ or to the fact that any function will be periodic if and only if its argument is periodic modulo some modulus.

Classroom conversations and self-reports of students’ high school and college mathematical experiences suggested that they and their instructors had engaged largely in “symbol speak” – talking about notations and notational actions without mentioning an interpretation of the notations themselves. As a result, students had learned to focus their attention on internalizing patterns of figural actions – the kinds of things to write, where to write them, and so on. Later excerpts will show the ways in which students expressed an orientation to notational action patterns sans interpretation during the teaching experiment.

The Teaching Unit

The class met twice weekly for 1.5 hours each meeting between February 2 and March 4, 1993, for a total of 10 meetings. Students had ready access to a computer lab or had a computer at home on which to work on assignments. The last two

meetings – those in which the Fundamental Theorem of Calculus was discussed – were videotaped and transcribed. A small-group session after the last meeting was also videotaped and transcribed.

The teaching experiment was structured to focus on four phases of conceptual development. These were:

- Phase I: Analyze behavior of functions' graphs; explain their behavior; Model situations using functions and derive information about situations from graphs (3 meetings)
- Phase II: Average rates of change; functions which give average rates of change over all intervals of a fixed length (2 meetings)
- Phase III: Accumulations of change: Riemann sums (2 meetings)
- Phase IV: Relationships among variable quantity, accumulation of change, and rate of change of accumulation (2 meetings)

The first phase focused on orienting students to reconstitute their images of function so that it would be based on images of covariation (Thompson, in press b). The second phase focused on having students enrich their notion of average rate so that they could express it as a difference quotient that reflected average rate of change over an increment of some quantity. The third phase focused on having students conceptualize Riemann sums as functions that describe an approximate accumulation of one quantity with respect to variations in another. The unit was intended to culminate in Phase IV by asking students to bring these separate developments together in the context of problems that highlighted the inverse relationship between accumulation and accrual so that they would have an occasion to construct, for themselves, the Fundamental Theorem of Calculus. It was my hope that students would construct the Fundamental Theorem of Calculus; the larger aim of the teaching experiment, however, was to highlight aspects of their conceptions and orientations that might facilitate or obstruct such a construction.

It is important to note that all through the teaching experiment I gave explicit attention to students' images of mathematical activity, with special reference to uses of notation and the construction of explanations. It was essential that they come to interpret notation as someone's attempt to say something – and hence they should reflect on what was intended to be said, and that they should use notation as a medium for expressing their images, inferences, and methods. But to express images, inferences, and methods it was also essential that they come to take these as important activities upon which to reflect. This was an uncommon orientation for most students, and the details of our contract were continually renegotiated.

I will briefly describe the teaching experiment's first three phases to illustrate the nature of instruction and orientation I took to the subject, and to give a sense of the students' orientations. I will describe the fourth phase in detail.

Phase I: Functions, Graphs, and Models (3 meetings)

Students were given two assignments aimed at their developing insight into the behavior of functions by examining the behaviors of their graphs. Examples

TABLE I

Sample tasks from Phase 1 of the teaching experiment. Roman numerals indicate assignment number during the teaching experiment

- I.2. Investigate the behavior of these functions. Explain *why* they behave the way they do. [Note: A good explanation is one which, if understood ahead of time, would have allowed you to *predict* the behavior of the function.]

$$f_2(x) = x \sin(1/x)$$

$$f_3(x) = \cos(x) + 0.01\text{abs}(\cos(100x))$$

$$f_6(x) = x^2 \bmod 2$$

Answer each of the following questions by constructing appropriate functions and then using Analyzer to graph the functions and estimate the question's answer. For each problem, hand in:

- a labelled diagram,
 - a statement of what the function represents,
 - an explanation of what the function's graph shows you about the situation,
 - a note about what you looked for in the graphs to answer the question.
- II.1. Jamie Johnson rides frequently with her father to Chicago. One one particular trip it took 2 hours for them to travel the 110 miles from home to Chicago. They made the trip in two parts. Jamie kept an eye on the speedometer and estimated that in the first part they averaged 40 miles per hour. She estimated that in the second part they averaged 60 miles per hour. About how long did they drive in each part of the trip?
- II.7. Statistical data from trucking companies suggests that the operating cost of a certain truck (excluding driver's wages) is $12 + x/6$ cents per mile when the truck travels at x miles per hour. If the driver earns \$6.00 per hour, what is the most economical speed to operate the truck on a 400 mile turnpike where the minimum speed is 40 miles per hour and the maximum speed is 65 miles per hour?

of tasks from these assignments are given in Table I. Classroom discussions emphasized that Cartesian graphs are made of points, and the points in a graph are positioned in a way that reflect each value of a function in relation to the argument that produces that value. Functions as models of dynamic situations were emphasized through problems like II.1 and II.7 (Table I).

Phase II: Average Rates and Functions (2 meetings)

The derivative of a function is typically developed pointwise. That is, it is defined with the understanding that x in the expression

$$f'(x) = \lim_{h \rightarrow 0} \frac{f(x+h) - f(x)}{h}$$

is fixed relative to h . My instruction on rates of change drew from an example developed by David Tall (Tall, 1986; Tall et al., 1988) wherein x in the definition of $f'(x)$ is free to vary for each value of h . This alternative approach to the

derivative has two very natural interpretations. The first is that for a fixed value of h , the function

$$f_h(x) = \frac{f(x+h) - f(x)}{h}$$

gives the average rate of change of f over every interval of length h contained in the domain of f . The second is that

$$f_h(x) = \frac{f(x+h) - f(x)}{h}$$

gives the slopes of every secant which connects the points $(x, f(x))$ and $(x+h, f(x+h))$. The second interpretation supports an image of a “sliding secant” – slide an interval of length h through the domain of f , thereby sliding the secant defined over that interval, and keep track of the secant’s slope. The relationship of either interpretation to the standard definition of the derivative is that as we let h approach 0 we produce a family of functions that converges to the function which gives the instantaneous rate of change of f at every value in the domain of f where the pointwise limit exists.

The reason for my taking this approach to the derivative is that the notion of function is always uppermost in any discussion of a function’s rate of change. It also encourages students to think of a function’s rate of change in concrete settings in ways that are consistent with ideas of rate of change over some interval. Finally, I intended that their image of a function’s average rate of change over a small interval would come into play when thinking of the relationship between accumulations and accruals in Phase IV.

Table II presents sample tasks from Phase II of the teaching experiment. The tasks here were oriented toward conceptualizing the derivative as a function that is approximated by a “Newtonian ratio,” a jargon phrase concocted during the teaching experiment to refer to $f_h(x)$.

I was surprised by the nature of students’ difficulty in interpreting the functions they defined for III.4 (Table II). Excerpt 3 provides an interchange between myself and two students in the computer lab after they had developed and graphed the function

$$r(x) = \frac{d(x+0.1) - d(x)}{0.1},$$

where $d(x)$ was defined as $d(x) = 16x^2$. Bob is a high school mathematics teacher, Alice is a mathematics education masters student.

EXCERPT 3

- 3.1 Bob: We’re having trouble making sense of what we’re looking at.
 3.2 Alice: Or even what we did!
 3.3 Pat: Okay, what is this function you typed? What does it represent?

TABLE II

Sample tasks from Phase 2 of the teaching experiment. Roman numerals indicate assignment number during the teaching experiment

-
- When an object falls from a resting start, the distance it has fallen t seconds after being released is given by the function $d(t) = 16t^2$ (assuming we ignore resistance).
- III.3. An engine fell off a DC 9. What was the engines average vertical speed between 3.1 seconds and 3.2 seconds after it started falling? Between 3.2 and 3.3 seconds? Between 3.15 and 3.25 seconds? (Answer these questions using just paper-and-pencil.)
- III.4. Use Analyzer to produce a graph of the engine's average vertical speed over every 1/10th second interval. (*Don't fall into the trap of thinking that the only 1/10th second intervals are $(0, 0.1]$, $(0.1, 0.2]$, $(0.2, 0.3]$, and so on.* In stead, think of a "sliding interval" that has every value in the domain as its left end point.)
- III.5. Generalize part (III.4) so that your function uses a parameter. Play around with different values of the parameter to generate a family of functions which approximate the function that gives the engine's vertical speed at every *instant* of time after it began falling.
- III.8. Jayne, the clas trouble maker, asked a question about (III.5). She said, "If we think of an object at an *instant* of time, then it didn't move any distance over that instant of time, and it didn't take any time to move nowhere. So, what can it possibly mean to talk about the object's *speed* at an instant of time when speed is about moving some distance in some amount of time?" Comment on Jayne's dilemma.
- III.10. Use the technique developed in [earlier problems] to define a function whose values approximate the instantaneous rate of change of the function $g(x) = \cos(x)e^{\sin(x)}$ at all values of x in $(-10, 10)$.
-

- 3.4 Alice: That's what we can't figure out.
- 3.5 Pat: How did you come up with it at all?
- 3.6 Bob: We just put letters in for numbers [referring to their solutions to III.3, Table II].
- 3.7 Pat: Okay, let's take it a piece at a time. What does $d(x + 0.1)$ represent?
- 3.8 Bob: How far it went in one tenth of a second.
- 3.9 Alice: How fast it is going.
- 3.10 Pat: Well ... I don't understand how you came up with your interpretations.
- 3.11 Alice: I was guessing (*laughs*).
- 3.12 Bob: It's like this ... $d(x)$ gives how far the engine dropped in x seconds, so $x + 0.1$ is another tenth of a second. So $d(x + 0.1)$ gives how far it went in that extra tenth.
- 3.13 Pat: How far it went in just that tenth of a second, or how far it fell altogether in $x + 0.1$ seconds?
- 3.14 Alice: Oh ... it has to be how far it fell in the whole amount of time.
- 3.15 Bob: I don't ... (*pause*)
- 3.16 Pat: Let's change the subject for a little while. If I were to tell you how far this engine fell in 7 seconds, what would you need to know to tell me how far it fell in the last two seconds?
- 3.17 Bob: (*Pause.*) How far it fell in the first 5 seconds.

- 3.18 Alice: Then you'd subtract.
- 3.19 Pat: You'd subtract what to get what?
- 3.20 Alice: Subtract how far it went in 5 seconds from how far it went in 7 seconds to get how far it fell in the last 2 seconds.
- 3.21 Pat: How would you calculate the engine's average speed during those last 2 seconds?
- 3.22 Bob: Divide by 2.
- 3.23 Pat: Divide what by 2?
- 3.24 Both: The distance it went in the last 2 seconds.
- 3.25 Pat: Now, tell me again what $d(x + 0.1)$ and $d(x)$ represent?
- 3.26 Bob: How far ... how far ...
- 3.27 Alice: How far it fell in $x + 0.1$ seconds and how far it fell in x seconds.
- 3.28 Pat: Okay, what does the difference of those two represent?
- 3.29 Bob: How far it fell in the last tenth of a second?
- 3.30 Pat: Not necessarily the last tenth, just the tenth of a second after x seconds of falling. (*Pause.*) Now, what does $r(x)$ represent?
- 3.31 Both: How fast it went during that tenth of a second.
- 3.32 Pat: Was it always going one speed during that tenth of a second? (*Long pause.*)
- 3.33 Alice: Oh ... its *average* speed during that tenth of a second!
- 3.34 Pat: Okay! Now, what does the graph of $r(x)$ represent?
- 3.35 Alice: How fast ... how fast ...
- 3.36 Bob: It's average speed ... after ... (*to himself*) when?
- 3.37 Alice: It's average speed ... over ... over ... every one-tenth interval ... one-tenth second. Over every one-tenth second interval of time!
- 3.38 Bob: Oh.
- 3.39 Pat: Okay (*enters "r(1.5)" at keyboard; program prints "49.60"*), this says that $r(1.5)$ is 49.6. What does that mean?
- 3.40 Bob: It was going 49.6 feet per second after one and a half seconds.
- 3.41 Alice: It went an average speed of 49.6 feet per second when it fell from 1.5 seconds to 1.6 seconds.

Bob's difficulty was not uncommon. Those students who experienced difficulty seemed to want to think of the difference quotient as "the derivative" and interpret it as "how fast it [the function] is changing," without interpreting the details of the expression as an amount of change in one quantity in relation to a change in another. Several students chose to write the difference quotient in their homework as

$$\frac{f(x+h) - f(x)}{(x+h) - x}$$

I presume this was a mnemonic to help them keep in mind that the denominator was also a difference and that the quotient evaluated a multiplicative comparison of changes.

My intention for Item III.8 (Table II) was to orient students to thinking of instantaneous velocity as a limit of average velocities. In fact, students' responses surprised me. Of the 12 responses turned in, all said essentially that they would

explain to Sue that “instant” was not really an instant, but an amount of time so small that it was virtually indistinguishable from zero seconds.

Phase III: Riemann Sums (3 meetings)

I introduced Phase III with a discussion of Sue’s problem and solution, as presented earlier in this article (Figure 5). I was struck by the direction taken by students: A consensus emerged that, had they been Sue’s teacher, they would have had Sue “discover” that she could just multiply the amount of time taken to speed up by the mean of the beginning and ending speeds. Sue’s solution method was, to them, a rather clumsy way to approximate “the correct answer.” I asked, “Does Sue’s solution have anything to do with calculus?” “No.” I then presented Sue’s problem with a variable acceleration, asking “Which method will generalize to this new setting – yours or Sue’s?” Eventually they demurred that there might have been more sophistication in Sue’s reasoning than they originally recognized.

Instruction during Phase III focused on conceptualizing a Riemann sum as a function and on conceptualizing dynamic situations as representable by Riemann sums (see Table III). A major difficulty for many students was to express functional relationships in situations analytically, and to coordinate their images of functional covariation of two quantities with an image of accumulation by way of accruing “chunks” of a quantity. The notion of a Riemann sum as presented in Phase III – an approximation to a variable accumulation – often conflicted with their images of definite integral and Riemann sum as applying only in situations involving *fixed* amounts of some quantity (the typical scenario in freshman calculus). This conflict revealed itself in a number of ways – a common one being that a student would write an expression for a Riemann sum, but with an image that what he or she was finding was a *total* amount of a quantity (e.g., total work, area, volume, etc.) instead of a varying amount of the quantity.

I gave special attention to items like IV.5 and IV.6 in Table III. The reason for this was to give students an occasion to reflect on the details by which the process of Riemannian summation assigns values to its argument. The first case (IV.5) corresponds to assigning a fixed subinterval length in any partition of the interval $[0, x]$. For $x \in [i\Delta x, (i + 1)\Delta x]$ the expression $[x/\Delta x]$ is constant, so

$$\sum_{i=1}^{x/\Delta x} f(i\Delta x)\Delta x$$

is constant over that interval,¹¹ and hence

$$\sum_{i=1}^{x/\Delta x} f(i\Delta x)\Delta x$$

produces a constant function over each of the subintervals through which x varies – a step function. The second case (IV.6) corresponds to assigning a fixed number of subintervals in any partition of $[0, x]$. As x varies, the number of subintervals

TABLE III

Sample tasks from Phase 3 of the teaching experiment. Roman numerals indicate assignment number during the teaching experiment

-
- IV.1. a. Use Analyzer and Riemann sums to produce a graph of the approximate velocity of a car during its first 10 seconds of accelerating from a standing start when it accelerates at the rate of 11.5 mi/hr/sec.
- b. Use Analyzer and Riemann sums to produce a graph of the approximate distance covered by a car during its first 10 seconds of accelerating from a standing start when it accelerates at the rate of 11.5 mi/hr/sec.

IV.2. Use Analyzer and Riemann sums to produce a graph of the volume of water in a conical storage tank that is 25 feet high and 30 feet wide at the top. Express the volume as a function of the height of the water above the tip of the cone.

- IV.5. a. How might you think of the expression

$$\sum_{i=1}^{x/\Delta x} \cos(i\Delta x)\Delta x$$

to understand that it defines a Riemann sum evaluated at every value of x in your domain?

- b. Explain why the Riemann sum defined this way *always* produces a step function, regardless of the value of Δx (assuming it is not zero).

- IV.6. a. How might you think of the expression

$$\sum_{i=1}^n \cos\left(i\frac{x}{n}\right)\frac{x}{n}$$

to understand that it defines a Riemann sum evaluated at every value of x in your domain?

- b. Explain why the Riemann sum defined this way *never* produce a step function, regardless of the value of n .
-

in the partition remains the same, but the subintervals “stretch” proportionally as x gets proportionally larger. In both cases I emphasized that they should try to imagine the process of Riemann summation as happening so rapidly that they could think of x varying freely and the process would keep up with it. That is, as x varies, the process of summation happens at each value of x , and the process happens “so rapidly that it doesn’t slow x down – you can slide x along its domain and not feel any resistance from the process as it tries to keep up.”

Phase IV: The Fundamental Theorem of Calculus (2 meetings)

I did not introduce the Fundamental Theorem of Calculus as such. Instead, I continued a discussion of one Riemann sum problem that students had found particularly troublesome. The problem was:

Hexane is a gas used for industrial purposes. Clentice Smith of Cargill Corp., Bloomington, IL in November, 1989 requested a graph that will give the approximate volume of hexane (measured in cubic inches) held by the tank shown in Figure 8. Use Analyzer and Riemann sums to produce

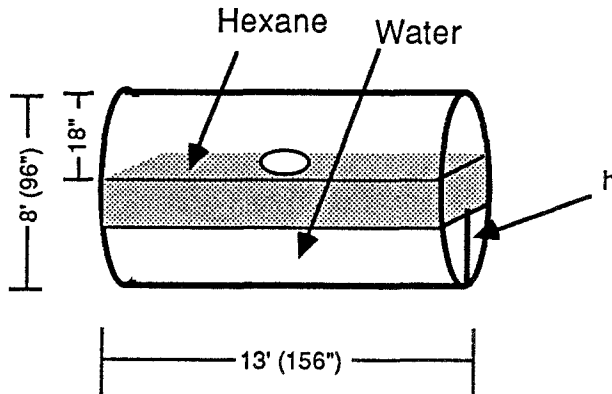

Fig. 8. A tank with water in the bottom and hexane sitting atop the water. The hexane always reaches the hole in the tank's side regardless of the height of the water.

such a graph. Express the volume of hexane as a function of the height of the water (measured in inches).

Assumptions

- The face of the tank is a disk (i.e., a region bounded by a circle)
- the shape of the tank is cylindrical
- the hexane sits atop the water
- the dimensions of the tank are as shown
- a hole in the tank resides 18" vertically from the top of the tank
- the hexane always reaches the bottom edge of the hole.

My intention with this problem was to recap students' solutions and use the discussion as a setting for asking about, what would turn out to be, the Fundamental Theorem of Calculus. I intended to do this by graphing the width of a horizontal slice of the tank's face as a function of the slice's height from the floor, graphing the area of the face's water-covered portion as a function of the water's height, and then ask about how fast the water-covered portion's area changes with respect to the water's height. I presumed that students would suggest a difference quotient to estimate the function which gives rate of change of area as a function of the water's height, and I planned then to graph this difference quotient and ask students to compare its graph with the graph of the horizontal-slice width as a function of height (anticipating that the two graphs will appear to be identical). The culminating question would be, "If this graph is of the width of a horizontal slice as a function of its height from the tank's bottom, and the other graph is of the rate of change of area as a function of the region's height from the tank's bottom, then why do they look the same? Is there some reason for it, or is it just coincidence?"

The session began with one student's, Blake's, presentation of his solution to the problem. He established that the main aspect of this problem was to express the area of the water-covered region of the tank's face as a function of the water's height from the bottom. Blake then defined a function to give the width of an

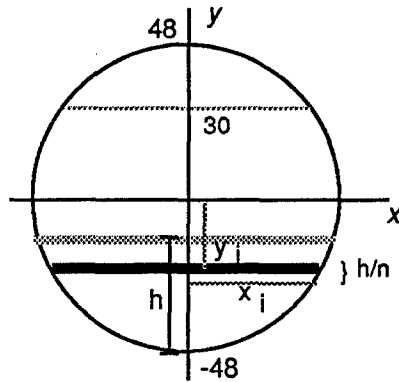

Fig. 9. Face of cylindrical tank. Water level is at height h measured from tank's bottom, with i th rectangle in partition highlighted; x_i and y_i are coordinates of the i th rectangular piece's lower-right corner.

arbitrary chord as a function of its height (Figure 9) and set up an appropriate Riemann sum as a function of the water's height.

After Blake had completed his presentation I displayed his equations on a projector screen.¹² They are presented below as Equation Set 1. The function $x(h)$ gives the x -coordinate of a chord's right endpoint expressed as a function of the chord's height above the bottom of the circular face (Figure 9). The function $w(h)$ gives the chord's width. The function $A(h)$ gives the approximate area of the water-covered portion of the tank's face as a function of water's height. The function $V(h)$ gives the approximate volume of the hexane as a function of the water's height.

$$n = 20 \quad \text{E1.1}$$

$$x(\mathbf{h}) = \sqrt{48^2 - (-48 + \mathbf{h})^2} \quad \text{E1.2}$$

$$w(\mathbf{h}) = 2x(\mathbf{h}) \quad \text{E1.3}$$

$$z = w(h) \quad \text{E1.4}$$

$$A(\mathbf{h}) = \sum_{j=1}^n w\left(j \frac{\mathbf{h}}{n}\right) \frac{\mathbf{h}}{n} \quad \text{E1.5}$$

$$y = A(h) \quad \text{E1.6}$$

$$\text{Total Area} = A(78) \quad \text{E1.7}$$

$$V(\mathbf{h}) = 156(\text{Total Area} - A[\mathbf{h}]) \quad \text{E1.8}$$

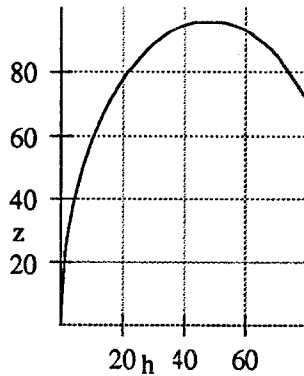

Fig. 10. Graph of $z = w(h)$, the width of a cross section as a function of the cross section's height above the cylinder's bottom.

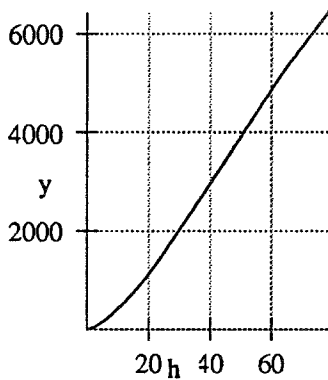

Fig. 11. Graph of $y = A(h)$, the approximate area of the tank face's water-covered portion as height of water increases.

$$v = V(h)$$

E1.9

Equation Set 1: Blake's system of equations and functions for the Hexane problem.

We discussed Figure 9 and its relationship to the functions $x(h)$ and $w(h)$, shown above as E1.2 and E1.3, and we discussed the graph of $w(h)$ [Figure 10].

The discussion of $A(h)$ first centered around interpreting its construction, which was not straightforward for some who still had questions. After I was satisfied that everyone understood the construction of $A(h)$ and $V(h)$, I displayed a graph of $y = A(h)$ (Figure 11) and then redirected the focus of the lesson by asking about the rate of change of area of the face's water-covered portion as the water's height increases. The ensuing discussion is given in Excerpt 4.

EXCERPT 4

- 4.1 Pat: Let me back up a little [*scrolls back to equation E1.5*]. I want to ask you a question. We had this area function [*highlights E1.5*]. Suppose that I ask you the question, “How could we get a function that approximates how fast the area is changing as the height increases?” [*moves hand upward to indicate an increasing water height.*]
- 4.2 *Long pause.*
- 4.3 Student: Tangent to the slope of the line.
- 4.4 Bob: You basically take a tangent at any point on the curve ... on your area function.
- 4.5 Pat: Okay. Do you know how to do that?
- 4.6 Bob: *Pause.* Basically, by taking limits ... I’m trying to remember this stuff.
- 4.7 Jim: Isn’t it just that limiting thing that we’ve been doing?
- 4.8 Pat: That limiting thing?
- 4.9 *Laughter.*
- 4.10 Alf: It’s just the difference quotient, isn’t it?
- 4.11 Pat: Alf?
- 4.12 Alf: The difference quotient, where
- 4.13 Jim: The moving secant line.
- 4.14 Alf: Yeah.
- 4.15 Alice: Oh yeah!
- 4.16 Alf: It would be f of x plus h minus f of x all over h .
- 4.17 Pat: What would that give you?
- 4.18 Student: The speed.
- 4.19 Pat: The speed of what?
- 4.20 Alf: The speed for how fast the area is changing.
- 4.21 Pat: How does this give you what you say?
- 4.22 Jane: It’s like average speed.

My question about how fast the area changes with respect to height appeared to take them by surprise. The first two responses seemed to emanate from a concept image of derivative as slope of a tangent. Only when Alf spoke of the difference quotient (§ 4.10) did the idea of average rate of change over a small interval of height emerge.

How to express the difference quotient of change in area in relation to change in height was problematic for a number of students, despite Alf’s suggestion (§ 4.16). After a consensus emerged on how to express the difference quotient, I entered the equations shown in Equation Set 2 and displayed a graph of the approximate rate of change in area with respect to height (Figure 12).

$$dA(\mathbf{h}) = \frac{A(\mathbf{h} + \Delta h) - A(\mathbf{h})}{\Delta h} \quad \text{E2.1}$$

$$\Delta h = 0.01 \quad \text{E2.2}$$

$$q = dA(h) \quad \text{E2.3}$$

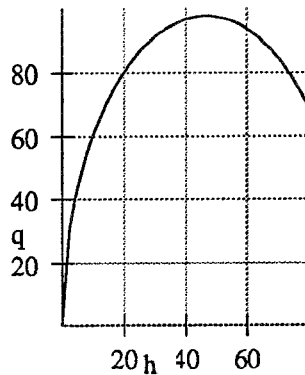

Fig. 12. Graph of $q = dA(h)$, the approximate rate of change of the water-covered portion's area as a function of the water's height.

Equation Set 2: Equations to define and graph the difference quotient which gives the approximate rate of change of the water-covered portion's area with respect to the water's height.

Excerpt 5, below, presents the discussion immediately following my presentation of Figure 12. It began with “what does this graph show us,” but quickly moved to why it appears to be the same as the graph shown in Figure 10.

EXCERPT 5

- 5.1 Pat: What does this graph [Figure 12] show us?
- 5.2 Several: The rate at which the area is changing.
- 5.3 Pat: What shows me the rate at which the area is changing when the height is 20 inches.
- 5.4 Alice: It's whatever q is when h is 20.
- 5.5 Pat: Does this graph look familiar?
- 5.6 Jane: It looks like the ... the uh ... the base of the rectangle that we had.
- 5.7 Roy: Oh ... of course.
-
- 5.8 Pat: *Moves the graphs shown in Figure 12 and Figure 10 so that they are side by side on the projector screen.*
-
- 5.9 Bob: What was the one on the left again [Figure 10]?
-
- 5.10 Alf: The derivative of ... [several students speak at once] ...
- 5.11 Pat: That's how fast the area is changing as a function of h .
- 5.12 Bob: And it's changing in the same respect as that thing [pointing to diagram shown in Figure 9] is getting wider.
- 5.13 Alice: [to herself] That makes sense.
- 5.14 Pat: *Pause.* Why?
- 5.15 Bob: *Pause.* Why? Because that's what you multiplied it by!

- 5.16 Pat: What do you mean, “That’s what I multiplied it by?”
- 5.17 Bob: You’re taking the change in x [*spreading his hand apart horizontally*] and multiplying it by as it changes here [*holding his thumb and forefinger slightly apart vertically*] ... as the chord length changes ... the change in x gives you one of those little rectangular boxes we’ve been talking about.
- 5.18 Pat: Yeah.
- 5.19 Bob: Now, as that changes, as it gets larger, then the area is going to get larger. Now, I know ... I got it in my mind but it’s not coming out my mouth.
- 5.20 Pat: Can anyone reinterpret what Bob is saying? *Pause.*
- 5.21 Alice: I’m having the same problem ... how to say it.

Bob’s remarks (beginning in ¶ 5.12) seem to have emanated from a loosely articulated collection of images. It appears that he had an image of a chord moving up (¶’s 5.12, 5.17, 5.19), getting wider as it moves up (¶ 5.19). Bob referred to a “change in x ” (¶ 5.17), but it seems more like he had in mind what might more appropriately be called “a changed x ”, “a changing x ”, “another x ,” or even perhaps “a bigger x ” – where “ x ” referred to either a chord or the length of a chord. In (¶ 5.17), Bob referred to getting “one of those little rectangular boxes.” In (¶ 5.19) Bob referred to the area changing as “that” changes, presumably meaning that the area changes by moving the chord upward, thereby accumulating another “little rectangular box.”

Bob’s image, as described in the previous paragraph, gives him insight into the accumulation of area, but it is not an image of the rate of change of area with respect to height. Bob still needed to relate the change in area to the change in height – in the same way that one would relate a change in distance to a change in time to develop insight into speed as rate of change of distance with respect to time.

Bob quit his attempt to explain what he had in mind. Alf and Alice then entered the discussion. Alice eventually hypothesized that the two were somehow identical because they were both changing because of being functions of the height.

EXCERPT 6

- 6.1 Alf: Isn’t it that the area function is the change ...
- 6.2 Alice: The area function changes the ...
- 6.3 Alf: The area function is actually the change ... or the rate of change ... for the ... [*spreads hands apart*]
- 6.4 Bob: What’s staying the same in both?
- 6.5 Alice: When you change the height, you change the area, and when you change the height the width changes also ... so therefore ... did you follow that?
- 6.6 Pat: Go ahead.
- 6.7 Alice: So therefore ... when you want to find the rate of change of the area that’s going to go along with the rate of change of the width ... since they’re both a function of the height, they’re going to change the same ... together.
- 6.8 Pat: Paul, did you follow what Alice was saying?

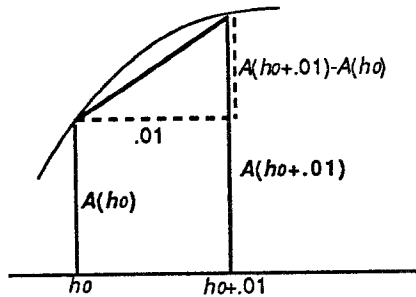

Fig. 13. Increase in area in relation to increase in h of 0.01 inches.

6.9 Paul: I doooooon't knooooow.
Laughter

Alice's hypothesis regarding the source of similarity between the two graphs (§ 6.5, 6.7) led eventually to rampant confusion. Students began to misinterpret graphs (e.g., saying that the graph of $z = w(h)$ shows the rate of change of the width, or that the graph of $q = dA(h)$ shows the area as a function of height) and to confuse volume with area. I decided to redirect the discussion to try to emphasize rate of change.

EXCERPT 7

- 7.1 Pat: Perhaps it would be helpful to come back to the area function [points at E1.5] and its graph [draws a section of the graph of $y = A(h)$ on the blackboard]. In terms of the graph, what we're doing at each value of h is to find the slope of a secant over an interval of length 0.01 [see Figure 13]. Let's label this point h_0 and this point $h_0 + 0.01$. What is this value [indicates vertical segment at h_0 ; note that Figure 13 shows all labels, but the vertical magnitudes were not yet labeled during this exchange]?
- 7.2 Bob: V of h .
- 7.3 Pat: Actually, it's A of h_0 – this is the graph of area as a function of height. What is this value [indicates right vertical segment]?
- 7.4 Several: A of h naught plus point zero one.
- 7.5 Pat: Okay. And this [indicates excess of $A(h_0 + 0.01)$ over $A(h_0)$ in Figure 13] is the difference between the two ... $A(h_0 + 0.01) - A(h_0)$. [Writes expression on blackboard. Diagram on blackboard now matches Figure 13].
- 7.6 We're looking at a little bit of area ... on the surface of that disk. So here is, if you like, $A(h_0 + 0.01)$ [draws diagram with \\\ hash marks; see Figure 14] and here is $A(h_0)$ [drawn //// hash marks: see Figure 14]. When you subtract $A(h_0)$ away [sweeps hand across //// hashed region], you're left with $A(h_0 + 0.01) - A(h_0)$. What is this [sweeps hand across difference region]? [Pause.] This is approximately the width at h_0 times the height of this little piece. The height is approximately what?
- 7.7 Student: Delta h .

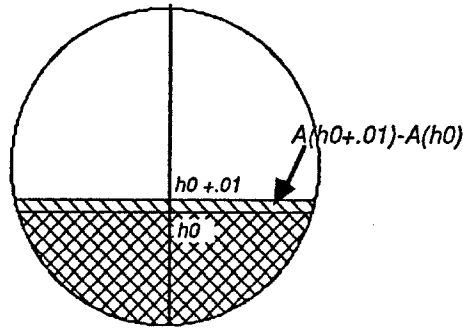

Fig. 14. "A little bit of area."

$$\underline{dA}(h_0) = \frac{\overbrace{A(h_0 + .01) - A(h_0)}^{w(h_0) \Delta h}}{\Delta h} \approx \frac{w(h_0) \cancel{\Delta h}}{\cancel{\Delta h}}$$

Fig. 15. Expression for approximating the average rate of change of region's area over the interval $[h_0, h_0 + \Delta h]$.

- 7.8 Pat: Point zero one, but in principle your right, it's delta h . [*Writes $w(h_0)\Delta h$ next to difference region.*] So this [*puts a bracket above $A(h_0 + 0.01) - A(h_0)$*] is approximately the width at h_0 times delta h [*writes $w(h_0) \times \Delta h$ above bracket*].
- 7.9 Alf: Divide that by delta h .
- 7.10 Pat: Yeah ... [*writes fraction bar under $A(h_0 + 0.01) - A(h_0)$, then Δh under fraction bar*] divide that by delta h , and guess what?
- 7.11 Alf:
Bob: You get the width.
- 7.12 Pat: You get approximately the width at h_0 . [*See Figure 15.*]
- 7.13 Jane: Hmmm.

My presentation in Excerpt 7 was too didactic to glean anything now about how students understood the role of rate in linking $w(h)$ and $dA(h)$. Also, in retrospect, I can see that the idea of rate of change moved to the background, becoming implicit in my remarks. I will return to this point later, in my discussion of the teaching experiment.

The next problem, IV.2 in Table III, asked for a Riemann sum that gives the approximate volume of water in a conical storage tank as a function of the water's height. Students had worked this problem earlier with little difficulty. The functions produced in that solution were $A(h) = \pi(\frac{15}{25}h)^2$, which gives the area of a cross-sectional disk as a function of the disk's height from the bottom of the cone, and $V(h) = \sum_{j=1}^n A(jh/n)(h/n)$, which gives the approximate volume of water when its height is h . I graphed $y = A(h)$ and $z = V(h)$, and then asked, as before, how we could express the approximate rate of change of the

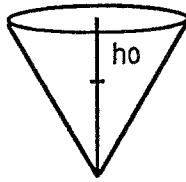

Fig. 16. Initial diagram in discussion with Sally.

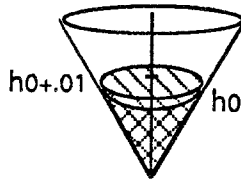

Fig. 17. Diagram of difference between volume at height $h_0 + 0.01$ and volume at height h_0 .

water’s volume as a function of its height. Several students suggested graphing the function.

$$DV(h) = \frac{V(h + \Delta h) - V(h)}{\Delta h}.$$

The graph of $DV(h)$ appeared identical to the graph of $A(h)$, and the discussion moved to trying to understand why we should expect them to be the same.

Many of the confusions seen in discussions of the previous problem surfaced again. Students confused “changing” with “rate of change,” and confused amount and change in amount. One student, Sally, eventually suggested that we “use the same argument as the last one.”

EXCERPT 8

- 8.1 Pat: Go ahead and say more.
- 8.2 Sally: With ... except for now we would have $\frac{V(h_0 + 0.01) - V(h_0)}{0.01}$.
- 8.3 Pat: So ... what kind of diagram should we use?
- 8.4 Sally: Visualize ... oh.
- 8.5 Pat: Here’s the cone [Figure 16]. How should I shade in $V(h_0)$?

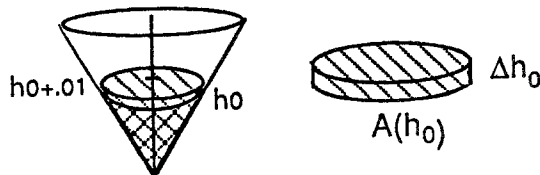

Fig. 18. Difference of $V(h_0 + \Delta h)$ and $V(h_0)$ approximated by product of area of base times height of cylinder.

- 8.6 Sally: So it would be the disk there with Δh as its height?
- 8.7 Pat: Just $V(h_0)$.
- 8.8 Sally: The disk ...
- 8.9 Pat: *Draws a disk centered at h_0 . You said a disk. Now, what is $V(h_0)$?*
- 8.10 Sally: *Pause.*
- 8.11 Pat: That's the volume of the cone from the bottom up to h_0 . [*Sweeps hand upward over diagram.*]
- 8.12 Sally: Oh ... okay.
- 8.13 Pat: So that's everything ... everything up to h_0 . [*Shades diagram. Writes " $V(h_0) = \backslash\backslash\backslash$ "*]
- 8.14 Sally: So ... V of h_0 plus point zero one or something would be just a little bit above it and would be everything underneath that?
- 8.15 Pat: All right. [*Writes " $V(h_0 + 0.01) = \backslash\backslash\backslash$ "*] So I would go up [*marks $h_0 + 0.01$*] ... this is $h_0 + 0.01$ [*draws disk at that height; shades in region below disk; see Figure 17*] and take everything under that. And what would we get?
- 8.16 Sally: And so when you subtract them you would get ... just a little chunk ... of volume.
- 8.17 Pat: That's right. We would get just a little bit of volume [*draws inset of difference; see Figure 18*]. How high is this chunk?
- 8.18 Sally: 0.01.
- 8.19 Pat: 0.01. Or ... let's use Δh .
- 8.20 Sally: Yeah, Δh .
- 8.21 Pat: So, it's Δh high. *Pause.* And this is ... [*indicates base of inset*]?
- 8.22 Alf: The area.
- 8.23 Jim: The area.
- 8.24 Pat: $A(h_0)$, isn't it? So, $V(h_0 + \Delta h) - V(h_0)$ is ... the volume of this little chunk. So, how could we express that given what we know over here [*points to diagram shown in Figure 18*]? Jim?
- 8.25 Jim: $A(h)$ times Δh .
- 8.26 Pat: [*Completes previously started sentence. Writes $V(h_0 + \Delta h) - V(h_0) \approx A(h_0)\Delta h$.*] So, what happens when we divide by Δh ?
- 8.27 Several: You just get the area.

As in the discussion of the previous problem, I allowed the idea of rate of change to move to the background, becoming implicit in my remarks. It is not clear from Excerpt 8 whether students understood that the expression

$$\frac{V(h_0 + \Delta h) - V(h_0)}{\Delta h}$$

evaluated an *average* rate of change of volume with respect to height of a cylinder over the interval $[h_0, h_0 + \Delta h]$, which in turn gave the average rate of change with respect to height of the total volume over that interval. We will see that it is unlikely that they understood the discussion to be about rates.

I met a small group of students after class – the number varied during the meeting, starting with four and ending with seven. The purpose of the meeting

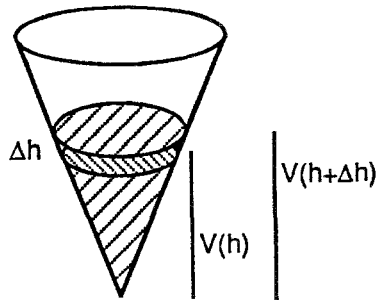

Fig. 19. Students' diagram for identifying amount of change in volume as water rises in height within a conical storage tank.

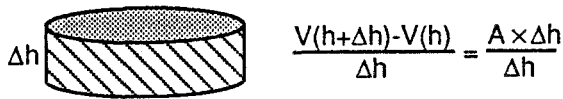

Fig. 20. Students' reproduction of diagram drawn during class discussion.

was for students to ask questions and discuss their confusions. Blake, Roy, Adam, and Fred had already begun discussing the “cone” problem, and had drawn Figure 19 and Figure 20 on the blackboard before I joined them.

The four of them had been discussing “how the surface area and volume are related.” Blake spoke to me as I joined the group.

EXCERPT 9

- 9.1 Blake: I'm not getting the connection I mean, in my mind I understand how they're the same. It's kind of like, to put it in words, how the surface area is related to the volume. How ... see, we're talking about the surface area ... the graph of that is the same as the rate of change of the volume ... they're both changing because they're both functions of ... delta h , the change in h .
-
- 9.2 Blake: To me, it's almost the same thing as when Alf was talking about when you take the derivative of something and then you want to go backwards to it. But they're both ... it's ... it's like I know what I'm thinking, but I can't say it. [Long pause.] Uh ... like how are they related? They're related because they're both functions of the height ...
- 9.3 Pat: Yeah, they're both functions of the height.
- 9.4 Blake: [Places thumb and forefinger over cylinder on blackboard; see Figure 20.] ... of how this disk is changing, I guess [spreads thumb and forefinger apart]. As the disk changes, because ... this height ... this delta h always stays the same [indicates thickness of cylinder with thumb and forefinger] but the surface area is changing [sweeps finger in a circular motion over the top of the cylinder].
- 9.5 Long pause. Paul joins the group.
- 9.6 I guess it's stupid to say that it's just common sense. As that surface area gets bigger [moves hands and fingers to show a “growing circle”] so that in one graph you're looking at the surface area ... the surface area ... that's ... there's no other way that the volume can change. [Pause.]

- 9.7 Pat: Is except by ...?
 9.8 Blake: As a function of the area. [*Pause.*]
 9.9 Pat: As a function of the surface area?
 9.10 Blake: Yeah, the surface area.

Blake's remarks suggest he was struggling with two sources of meaning for the identity between a cross-section's area and the rate of change of volume with respect to height. In (¶ 9.2) Blake referred to a remark made by Alf, during class, regarding a connection between the derivative of a distance function and the antiderivative of a speed function. This suggests Blake remembered something about an integral of a derivative somehow returning you to an original function. On the other hand, in (¶'s 9.1, 9.4–9.10), Blake appeared to be thinking of a circular disk moving upward, so that the surface area of the disk becomes larger while at the same time water fills the space generated by moving the disk upward. This image resembled Bob's remarks (Excerpt 5, ¶'s 5.17–5.19) and Alice's remarks (Excerpt 6, ¶'s 6.5–6.7) during class about the water-covered area of a tank's face changing as a chord gets wider. Adam's and Fred's comments in the ensuing conversation (Excerpt 10, below) follow Blake's predominant direction of thought – that the two graphs are identical because the two quantities are changing simultaneously.

EXCERPT 10

Discussion continues from Excerpt 9.

- 10.1 Pat: Okay. [*Pause. Speaks to Blake.*] So the volume changes ... here's where I'm not clear on what you're saying. It sounds like you're saying that volume changes as the surface area changes.
Alf joins the group.
- 10.2 Adam: [*Walks up to the board and points at the top cross section in Figure 19. Turns to Pat.*] Are you just thinking about this as a slab floating on top of the water ... as this [*the slab*] goes up [*moves hand upward*] ... as the surface area gets bigger [*moves hands apart to indicate a growing circle*] ... the volume underneath [*sweeps hand across region below the slab*] is going to change ... the same ... type of rate [*moves hand up and down in front of diagram in Figure 19*]. What I ... I just don't know how to explain it.
- 10.3 Pat: Same type of rate?
- 10.4 Adam: Well, it's ... this [*slab*] is changing ... is getting bigger [*shows growing circle with hands and fingers*] as you're going up, and this [*volume under slab*] is getting bigger as you're going up [*moves hands as if pushing the slab upward*].
- 10.5 Pat: Okay ... so they're both getting bigger.
- 10.6 Fred: But ... why is it that they're both the same?
- 10.7 Pat: Yes, that's the key question. Why is it that area turns out to be exactly the same as the rate of change of the volume? [*Pause.*] There's a qualitative similarity in that, yes, they are both getting bigger. But Fred asked the key question, "Why is it that they're identical?"
- 10.8 Fred: I don't know [*laughter*]. [*Very long pause.*]
- 10.9 Blake: Is it so simple that we're just overlooking it, or is it really that hard?
- 10.10 Pat: Well, it's partly in front of you.

- 10.11 Fred: I can see it algebraically when you put it in this kind of form [Figure 20], but I guess I have trouble visualizing it.

Adam's remarks in (§'s 10.2–10.4) are telling in two ways. First, he appears to have, like Blake and others, an image of a circular disk moving upward, thereby increasing its area, while the generated space increases in volume. Second, he seems to have identified “rate” with “change,” so that he ended up saying things like “as the surface area gets bigger ... the volume underneath is going to change ... the same ... type of rate” (§ 10.2). If Adam was indeed thinking of a rate, then it was the rate of change of volume with respect to area of the circular cross section. It appears, however, that by “same type of rate” he meant that the two quantities change simultaneously and in the same direction (increase) instead of as an amount of change in one quantity in relation to an amount of change in the other.

Fred's comments (§'s 10.6–10.11) are also telling in several ways. First, he appears not to have an articulated image of “they” in “But ... why is it that *they*'re the same?” (§ 10.6). If, as were Adam and Blake, Fred thought of “they” as “changing area” and “changing volume,” then his confusion is understandable. He was thinking of two things that are not the same. Second, if he was thinking of changing area in relation to changing volume, then it is evident why he could not visualize what is expressed in the formulation

$$\frac{V(h + \Delta h) - V(h)}{\Delta h} = \frac{A \times \Delta h}{\Delta h} \quad (\text{¶ 10.11}).$$

He was not thinking of the slab (Figure 20) as an accrual of volume – composed multiplicatively of disk area and height – in comparison to a change in height. Instead, Fred seemed to imagine the slab as that which defined the upper bound of the water.

I sensed the confusion between “both changing” and one quantity having the same value as the rate of change of the other, and attempted to refocus their attention on the ideas of rate of change of volume on the one hand and area of the disk on the other hand. This exchange is given in Excerpt 11.

EXCERPT 11

- 11.1 Pat: Well, here, let's try this. What I hear is a little mixing of the ideas of area, change in the area, and change in the volume. You're right that the volume only gets bigger when the area gets bigger. But thinking of it that way ... I don't see much hope in that giving us insight into why the rate of change of the volume is actually the same as the area function. [Pause.] The idea that as one gets bigger the other gets bigger doesn't seem to help much.
- 11.2 Blake: It doesn't mean that they necessarily have to be the same.
- 11.3 Fred: Is it something to do with this rate [indicates vertical change in water level] being exactly the same as that rate [indicates change in radius of circular cross section; see Figure 19]?
- 11.4 Pat: [Pause.] Uh ... I don't think they're the same.
- 11.5 Fred: The same ... proportion.

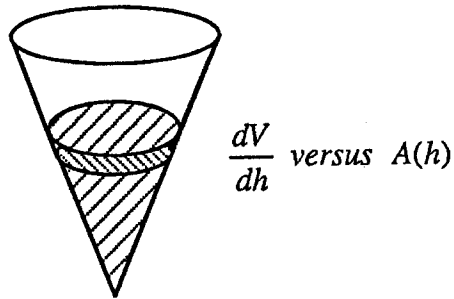

Fig. 21. Figure 19, revised during discussion.

- 11.6 Blake: Yeah ... those segments are proportional, but the rates of change are different. [Pause. Erases Figure 20.] Here's what we're comparing. We're comparing [writes " dV/dh "] the rate of volume with respect to h , versus area as a function of h [writes " $A(h)$ "]. See, over here [points to $A(h)$] we're not talking about any kind of rate of change; we're just talking about area of a cross section as a function of its height from the bottom of the cone. Over here [points to " dV/dh "] we're talking about a rate of change. [Long pause. Figure 20 is now erased from the board. Figure 19 is changed, appearing now as in Figure 21.]

In Excerpt 11 I attempted to point out that what was the same (the graphs of cross-sectional area as a function of height and rate of change of volume with respect to height) were expressions of two different concepts – cross-sectional area and rate of change of volume. The ensuing discussion makes it evident that my formal expression of rate of change of one thing versus an amount of something else was not assimilated in the way I had intended.

EXCERPT 12

- 12.1 Alf: Am I thinking of this right. This [points to " $A(h)$ "] is the area of the disk at some particular point [moves hand up and down as if along vertical axis through middle of the cone] ...
- 12.2 Pat: Yes, this is the area of a circular cross section.
- 12.3 Alf: At h [points to " $A(h)$ "].
- 12.4 Pat: At ... [moves hand vertically upward and then stops as if to show movement to a spot] at h .
- 12.5 Alf: At h ... so ... then ... if you were thinking about this [holds thumb and forefinger apart and next to top circular cross section in Figure 21, as if to measure its thickness] ... the change in volume [moves thumb and forefinger together, as if squeezing cylindrical slab, diminishing its height] ... as delta h gets small, the change in volume ... delta h ... let me think.
- 12.6 Pat: Go ahead and express the change in the volume, and then the rate of change in the volume with respect to height.

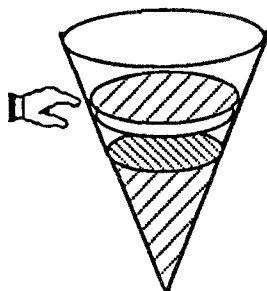

Fig. 22. Alf's addition to Figure 18. The hand depicted here represents Alf's hand; it was not part of Alf's drawing.

- 12.7 Alf: Okay, the change in volume [*holds thumb and forefinger apart; long pause before he approaches diagram in Figure 21*] ... [*places thumb and forefinger slightly apart next to top circular cross section in Figure 21*] ... the change in the volume would be some minute [*minuscule*] ... distance in height ...
- 12.8 Pat: Go ahead and draw it in.
- 12.9 Alf: [*Draws new circular cross section; diagram now appears as in Figure 22.*] See ... I can almost picture in my mind that as delta h goes to zero [*moves thumb and forefinger together next to top circular cross section in Figure 22*] that that becomes the exact area disk that we're talking about. I mean that's ... that's ... In other words, as I shrink that height, this [*top of cylinder*] and this [*bottom of cylinder*] becomes [*pushes hands together one atop the other, as if squeezing something between them*] ... exactly that [*holds out one hand flat, parallel to floor, moving it side to side as if stroking the top of a table*] ... like a disk with no thickness. And when you write it out as a volume ... let's see, I don't remember the notation we used ... how did we write it ... it would be

$$\frac{V(h + \Delta h) - V(h)}{\Delta h}$$

- 12.10 Fred: Equals.
- 12.11 Alf: And this would be the change in volume.
- 12.12 Blake: And you're saying that as delta h approaches zero, then we have, basically, ...
- 12.13 Alf: I see that as *being* the area

Despite my attempt in Excerpt 11 and in Excerpt 12, ¶ 12.6, to orient students to think about rate of change of volume, Alf persisted in thinking about an increment in volume unrelated to any increment in height. Moreover, he began to think of a limiting process whereby, figurally, when you diminish the accrual's incremental thickness, you *get* an area. Alf seemed to be thinking of making the cylinder shorter and shorter, until top meets bottom. His image could be described formally as

$$\lim_{\Delta h \rightarrow 0} V(h + \Delta h) - V(h) = A(h),$$

which would have meant that

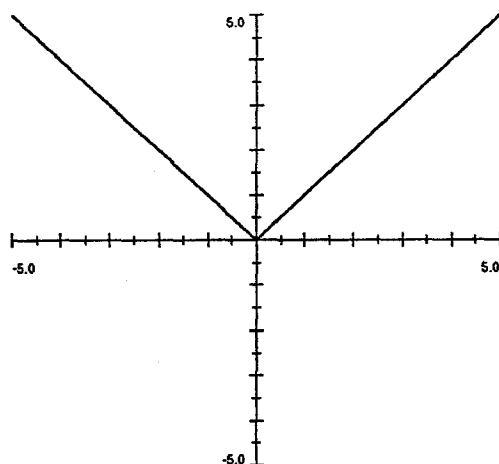

Fig. 23. Graph to accompany follow-up assessment item 2.

$$\lim_{\Delta h \rightarrow 0} \frac{V(h + \Delta h) - V(h)}{\Delta h} = \lim_{\Delta h \rightarrow 0} \frac{A(h)}{\Delta h},$$

an equality I cannot interpret. The “ Δh ” in the denominator of Alf’s difference quotient seemed insignificant to him. Perhaps this was because his focus was on the accrued “chunk” instead of on a meaning for the difference quotient that defined the function whose graph raised the issue in the first place.

There is a very natural interpretation of $[V(h + \Delta h) - V(h)]/\Delta h$ in regard to rate of change of accumulation. It is that it represents the average rate of change of volume over the interval $[h, h + \Delta h]$, where volume is *defined* by the value of the Riemann sum. Over the interval $[h, h + \Delta h]$, volume accrues by “stretching vertically” the cylinder having base area $A(h)$ – the area of the cross-sectional disk at height h .¹³ Since the base area of the cylinder is constant over $[h, h + \Delta h]$, the volume grows at the rate $A(h)$. This is analogous to the case of speed. If we are considering a total accumulation of distance as a function of time, and if we assume that over some increment of time the distance is accruing at a constant rate, then regardless of how distance has accumulated prior to this increment of time, the *total* accumulated distance is changing at that constant rate over this increment of time.

Follow-up Assessment

Students took an exam two meetings after the end of the teaching experiment. I included four items to clarify possible sources of difficulty – two items on interpreting a difference quotient and two items on Riemann sums as functions. The difference quotient items were:

TABLE IV

Students' responses to Test Item 3. Note: Responses regarding information and responses regarding unit do not necessarily correspond within rows. The columns are presented independently of one another

Information given by $x(t)$		Unit	
Response	Frequency	Response	Frequency
Ave. rate of change of volume	4	Cubic meters per hour	7
Derivative	6	Hours	2
Rate of change of cooling	5	Degrees/hour	3
Average volume	1	0.1	1
Average change in volume	1	Square meters	1
Surface area	1	Volume/time/time	1
No answer	1	Other	4

2. a. The graph in Figure 23 is of $f(x) = |x|$, $-5 \leq x \leq 5$. Sketch a graph of $h(x) = [f(x + \Delta x) - f(x)]/\Delta x$ over the same domain with $\Delta x = 0.5$. Use the coordinate system provided in the graph. *Hint: Imagine a sliding interval.*
- b. Suppose you let Δx become progressively smaller. Explain what happens to the graph of $h(x)$.
3. a. The volume in cubic meters of a cooling object t hours after removing a heat source is given by the function $v(t)$. Suppose a function $x(t)$ is defined as

$$x(t) = \frac{v(t + 0.1) - v(t)}{0.1}.$$

State precisely what information $x(t)$ gives about this object. (That is, don't tell me what $x(t)$ approximates. Tell me what information it actually gives.)

- b. What is the unit of $x(t)$?

On Test Item 2 (difference quotient of absolute value function) 17 of 19 students drew a graph of the derivative of $|x|$. Only two students attended to the behavior of the function between -0.5 and 0 . In follow-up interviews of each student, the 17 who drew a graph of the derivative of $|x|$ admitted thinking "derivative". The two who attended to $h(x)$'s behavior around 0 did not think of a rate of change or slope of a secant, but instead evaluated the function at different values of x and just happened to try values between -0.5 and 0 .

The results of Item 3 are given in Table IV. Four students referred to an average rate of change of volume. Two others referred to an average, but not an average rate. Six students said that $x(t)$ is a derivative; five said that it is a rate of change, but of cooling. Only seven students gave an appropriate unit for $x(t)$.

The Riemann sum items were:

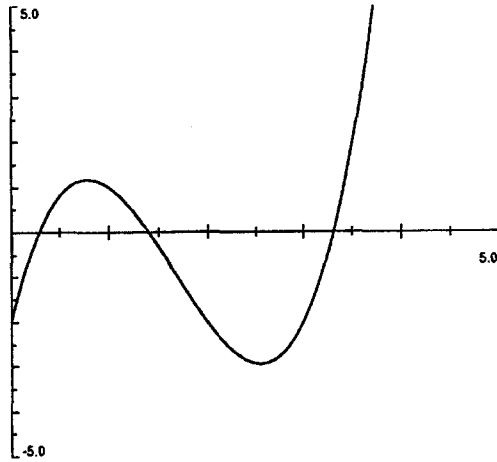

Fig. 24. Graph to accompany follow-up assessment item 4.

4. a. The graph in Figure 24 is of a function $q(x)$ defined over the interval $[0, 5]$. Sketch a graph of

$$z(x) = \sum_{i=1}^n q\left(\frac{i}{n}x\right) \frac{x}{n} \text{ for } n = 1000 \text{ and } x \text{ in } [0, 5].$$

Use the coordinate system provided in the graph.

- b. For what values of x (approximately) will $z(x)$ achieve a local maximum or a local minimum? Explain.
6. Let $q(t)$ be defined by

$$q(t) = \sum_{i=1}^{t/\Delta t} f(i\Delta t)\Delta t.$$

Explain the process by which the expression

$$\sum_{i=1}^{t/\Delta t} f(i\Delta t)\Delta t$$

assigns a value to $q(t)$ for each value of t in the domain of f .

Responses to Item 4 were difficult to interpret. Eight students sketched appropriate graphs. They claimed to have identified the Riemann sum as “area” and to have proceeded from that basis. Interviews with each student revealed a variety of reasons for inappropriate graphs. One student said “derivative” just popped into his head; several said that they didn’t know how to proceed when they didn’t know what the actual function was (i.e., they did not have an analytic definition of the function). Another student thought he should try to sketch a graph of the areas of each of the 1000 rectangles you would get for $z(5)$.

Responses to Item 6 showed that the coordination of images involved in

understanding Riemann sums as functions was a complex act. One student wrote:

First the value of a certain chunk is measured by $i\Delta t$. This is then multiplied by the change which is Δt . This is repeated for every value of t and then added up. Each value of t is cut up into $t/\Delta t$ intervals, and added. $t/\Delta t$ is the number of intervals the piece is to be divided up into.

This student evidently had a number of problems, one being that he was imagining a “chunk” of a quantity independently of the analytic expression that established its measure – $i\Delta t$ does not “measure” the chunk, it just puts you at the right place to make it. The expression $f(i\Delta t)\Delta t$ gives the chunk’s measure. A more serious problem, though, is that this student appeared to be imagining t and i varying simultaneously instead of as first i varying from 1 to $t/\Delta t$ for a fixed value of t and then varying t .

Another student wrote:

- Here Δt represents the size of each interval that f is being broken up into.
- So $t/\Delta t$ equals the number of intervals the graph of f is broken up into.
- So our i starts out at 1 and then goes to $t/\Delta t$.
- The expression first finds f and then it finds the i th interval of f that we are dealing with. Then it finds the value of the function f at that interval and then multiplies by Δt . This finds the area of that particular rectangle. Then we add it to the previous areas found and plot that point. You then connect all the points to get your curve.

The first sentence in this student’s explanation, “...the size of each interval that f is being broken up into,” suggests that she was imagining a Riemann sum over a fixed interval, which would normally correspond to an approximation of a definite integral $\int_a^b f(t)dt$ instead of the indefinite integral $\int_a^x f(t)dt$. Her last three sentences suggest that she, too, sometimes imagined i and t varying simultaneously.

Seven of 19 students expressed an appropriate order of variation for the index variable of the Riemann sum and the argument of the function. Five students appeared to have mixed images of definite and indefinite integrals. The remaining seven students had confounded the two variations so that everything was happening at once.

DISCUSSION

I structured the teaching experiment so that students were presented with a phenomenon requiring explanation: That when they graphed a function $f(x)$, defined the Riemann sum $g(x)$ as

$$g(x) = \sum_{i=1}^n f\left(i\frac{x}{n}\right) \frac{x}{n}$$

then graphed the function

$$Dg(x) = \frac{g(x + \Delta x) - g(x)}{\Delta x},$$

the graphs of $g(x)$ and $Dg(x)$ appeared identical for suitably large n and suitably small Δx . The functions were grounded in concrete settings, and explanations attempted by students' drew from their images and conceptions of the settings. My discussion will have three parts: Students' images as expressed during the teaching experiment and their contribution to students' difficulties, issues of notation, and implications of the present teaching experiment for standard approaches to the Fundamental Theorem and introductory calculus in general.

Students' Images

There seemed to be a confluence of images behind students' difficulties in construction and explanation for the problem of explaining an apparent relationship between $f(x)$, $g(x)$, and $Dg(x)$ as defined in the previous paragraph. These have to do with their images of function, their fixation on accrual as a solitary object, and a weak scheme for average rate of change. I conclude this section by relating the teaching experiment to Piaget's levels of imagery.

Images of Function

Students repeatedly made remarks that suggested a figural image of function – an image of a short expression on the left and a long expression on the right, separated by an equal sign (Thompson, in press b). This was not the only image students could conjure, but it seemed to be many students' "working image" – what came to mind without conscious effort whenever "function" was mentioned. This often oriented them away from grappling with conceptual connections entailed in situations dealing with covarying quantities.

In reviewing my notes and students work on assignments in Phase I, I noticed that students' explanations of the behavior of functions often spoke of the function's behavior as if it could be analyzed independently of its argument. Remarks were oriented to "the function" (often meaning the visual object called its graph) and not to a covariation of two variables. The analyses often referred to just one thing varying, this thing called "the function." Difficulties caused by an orientation to function as an idea with no interior showed up especially clearly when the function to be analyzed was a composition of functions. In analyzing the behavior of $f(g(x))$ it is critical to take into account the behavior of $g(x)$ in relation to x , for the variation of $g(x)$ is the variation of f 's argument.

Finally, it seems that students' images of Riemann sums were insufficient to support their reasoning about a sum's rate of change. I suspect they were thinking of a Riemann sum as being static – that even though its argument could change, and the Riemann sum could be evaluated with a new argument, it was still a sum of unvarying "chunks" and a change in its argument was more like substituting a new value for the argument than a continuous change in its value. Their images of a Riemann sum seem not to have entailed a sense of motion, either in its argument or in its value.

Accruals as Solitary Objects

Students' remarks regarding a relationship between the *rate of change of a Riemann sum* and a *constituent quantity* in an accrual to the sum¹⁴ always focused on the accrual as a solitary object (see especially Excerpt 12). To see a relationship between the two they needed either to conceptualize the accrual as itself accruing at a constant rate with respect to the independent quantity (e.g., height) or to conceptualize it as the average rate of increase in the accumulation over an increment in the independent quantity. In either case, it is necessary to have clearly in mind that accruals to the sum are constructed multiplicatively. In the first case, the accrual itself accruing at a constant rate, the accumulative quantity must be imagined to be constructed incrementally, where each increment is made by an increase in the quantity at a constant rate of change. In the second case, the accruals coming in "chunks", each accrual must be imagined to be a multiplicative combination of quantities (e.g., area and length) that will have increased at an *average* rate of change.

Students' fixation on accrual as a solitary object – simply as a thing with no constituent quantities – resembles young children's difficulties in constructing speed as a rate of change of distance with respect to time. Young children tend to think of speed as a distance – a measuring stick by which to measure other distances (Thompson and Thompson, in press; Thompson, in press a; Thompson and Thompson, 1992), and not something that grows in relation to a growing duration. This is not to say that the students in this teaching experiment understood speed in the same way as young children. Rather, it suggests that their schemes for rate and average rate were not operational to the extent that they could assimilate any covariate change to them.

Scheme for Average Rate of Change

A final source of difficulty, to which I already alluded in the previous section, was that students apparently did not have operational schemes for average rate of change. What do we mean by average rate of change of a quantity? We typically mean that if a quantity were to grow in measure at a constant rate of change with respect to a uniformly changing quantity, then we would end up with the same amount of change in the dependent quantity as actually occurred. An average speed of 55 km/hr on a trip means that if we were to repeat the trip traveling at a constant rate of 55 km/hr, then we would travel precisely the same amount of distance in precisely the same amount of time as had been the case originally. This notion is highly related to the Mean Value Theorem for derivatives, which says, in effect, that all differentiable functions do have an average rate of change over an interval and it is equal to some instantaneous rate of change within that interval. In the case of a Riemann sum, the rate of change of the sum for x within an interval $[q, q + \Delta q]$ is equal to the average rate of change of the quantity $f(t)\Delta t$ for some t in $[q, q + \Delta q]$ and for Δt varying from q to $q + \Delta q$ – which is just $f(t)$.

Coordination of Actions

As noted in the introduction, Piaget characterized his second level of imagery as, “In place of merely representing the object itself, independently of its transformations, this image expresses a phase or an outcome of the action performed on the object. ... [but] the image cannot keep pace with the actions because, unlike operations, such actions are not coordinates one with the other” (Piaget, 1967, p. 295). This seems to capture the nature of some students’ understanding of Riemann sum, and other students’ understanding of Riemann sum in relation to rate of change. Some students had not come to coordinate the variations of upper limit of summation and the variations in the index of the summation; some students had not coordinated the actions of forming a sum and multiplicatively constructing an accrual to a sum. Other students had mastered both of these coordinations but could not coordinate that ensemble of actions with the action of comparing multiplicatively the growth in an accrual with growth in one of its constituent quantities. As Piaget said, their actions outpaced their images because their actions were not coordinated. Operational understanding of the Fundamental Theorem entails the coordination of these actions so that the scheme remains in balance. Operational understanding of the Fundamental Theorem allows one to hold simultaneously in relation to one another the mental actions of forming accruals, accumulating accruals, and comparing an accrual to one of its constituent quantities multiplicatively.

Notation

I should point out that the above discussion is colored by one serious matter. This is that students often acted from an orientation which led them to use notation opaquely. We discussed this tendency during class on several occasions. A common remark was that this seemed, from their point of view, the most efficient way to cope with what they thought had been expected of them, both in high school and in college. When students did interpret notation, it often came as an afterthought, and they often tended to read into the notation what they wanted it to say, without questioning how what they actually wrote might be interpreted by another person. More often, though, students would not interpret the notation with which they worked, but would instead associate patterns of action with various notational configurations and then respond according to internalized patterns of action. Their orientation toward notational opacity, while having nothing to do with conceptual difficulties with the Fundamental Theorem of Calculus as such, certainly contributed to their not having grappled with key connections.

Implications for Contemporary Treatments of the Fundamental Theorem

The approach taken within this teaching experiment resembles Anton’s (1992, pp. 320–323) intuitive development of the Fundamental Theorem, with the exception that Anton does not employ Riemann sums and focuses exclusively on the case of area bounded by a function’s graph. Anton’s intuitive development is

not oriented at students' conceptualizing the Fundamental Theorem so much as to motivate his upcoming focus on techniques of antidifferentiation.¹⁵ A focus on techniques of antidifferentiation is historically accurate – Newton's and Leibniz' motivation for constructing the Fundamental Theorem was so that they could make algorithmic the process of constructing analytic expressions for areas under curves. However, Anton switches, unannounced, to another conceptualization in justifying the Fundamental Theorem – he bases it on the mean value theorem for integrals. The mean value theorem for integrals says that continuous functions have an average value over an interval, where the average value f_{av} over $[a, b]$ of a continuous function f is defined as $f_{av} = (b - a)^{-1} \int_a^b f(x)dx$ (Swokowski, 1991, p. 281). On the other hand, the mean value theorem for derivatives says that if f is continuous on a closed interval $[a, b]$ and differentiable on the open interval (a, b) , then there exists a number c in (a, b) such that $f'(c) = [f(b) - f(a)]/(b - a)$ (Swokowski, 1991, p. 179). The mean value theorem for integrals allows a formal proof of the Fundamental Theorem to go smoothly – we can substitute the average value of the integrated function for the integral of the function over the increment in its argument. On the other hand, the mean value theorem for derivatives supports a conceptualization of what is going on – the accumulation (integral) of the multiplicatively-constructed quantity $f(t)dt$ is changing at an average rate of change that is equal to $f(t)$ for some t in $[x, x + \Delta x]$.

A typical proof of the Fundamental Theorem goes something like this: Let $f(x)$ be a continuous function defined on $[a, b]$. Define $F(x)$ as $F(x) = \int_b^x f(t)dt$. Then

$$\begin{aligned} F'(x) &= \lim_{h \rightarrow 0} \frac{\int_a^{x+h} f(t)dt - \int_a^x f(t)dt}{h} \\ &= \lim_{h \rightarrow 0} \frac{\int_x^{x+h} f(t)dt}{h} \\ &= \lim_{h \rightarrow 0} \frac{f(z)h}{h} \text{ for some } z \in [x, x + h]. \end{aligned}$$

The last line is where the mean value theorem for integrals is used. The integral $\int_x^{x+h} f(t)dt$ is equal to $f(z)h$ for some z in the interval $[x, x + h]$. That is, the integral is equal to the average value of the function over the interval times the width of the interval. Then, as $h \rightarrow 0$, $z \rightarrow x$, and so $F'(x) = f(x)$.

The problem with the typical proof is not so much in the proof as that it is presented as modeling a static situation. It is presented in such a way that nothing is *changing*. If students are to understand $F'(x)$ is a rate of change, then something must be changing. But as soon as we bring in the idea of motion, then the mean value theorem of integrals becomes a conceptual misfit – it doesn't fit the image of $\int_a^x f(t)dt$ as a dynamic accumulation of a quantity. We must rely on the mean value theorem for derivatives to support the idea of rate of accumulation.

However, this teaching experiment suggests that a great deal of image-building regarding accumulation, rate of change, and rate of accumulation must precede their coordination and synthesis into the Fundamental Theorem.

NOTES

[†] Research reported in this paper was supported by National Science Foundation Grants No. MDR 89-50311 and 90-96275, and by a grant of equipment from Apple Computer, Inc., Office of External Research. Any conclusions or recommendations stated here are those of the author and do not necessarily reflect official positions of NSF or Apple Computer. Also, I wish to thank Paul Cobb and Guerchon Harel for their helpful reactions to an earlier draft of this article.

¹ Tom Kieren and Susan Pirie (Kieren and Pirie, 1990, 1991; Kieren, 1989; Pirie and Kieren, 1991) make it evident that the act of imagining can itself inform our images.

² The Latin root of "confused" is *confundere*, to mix together. Thus, one way to think of being in a state of confusion is that we create inconsistent images while operating.

³ Winograd and Flores (1986) give similar criticisms of referential meaning in cognitive science.

⁴ I should point out that when students speak of "rate" as in "distance equals rate times time," they need not be speaking of anything having to do with rate as I use the term. They may be engaging in mere "symbol speak," having no imagistic content except for the imagery of notational actions (Hayes, 1973).

⁵ This is a nonstandard interpretation. I am actually anticipating discussions regarding Newton's development of the Fundamental Theorem.

⁶ Here I must stress that I am talking about images and not about logical demonstration. The notion of accrual, when made rigorous, poses many problems regarding continuity of change and relationships between discrete and continuous quantities (this is the well-known problem of infinitesimals). But that is beside the present point – what sorts of images make the Fundamental Theorem *intelligible*.

⁷ We must keep in mind that during Newton's time all functions were thought to be continuous and differentiable almost everywhere. It was only later that pathological functions and Fourier series showed that these ideas could be pushed beyond a point where they became insufficient as a foundation for the calculus (Kuhn, 1970; Wilder, 1967, 1968).

⁸ I must stress once more that this is not a rigorous development. Rather, it is about images that might support the "obviousness" of the Fundamental Theorem. Also, it seems that Newton sensed the inadequacies of infinitesimals as a logical foundation for his calculus and eventually disavowed them (Boyer, 1959, p. 213). Nevertheless, it seems clear that his initial insights were facilitated by his acceptance of infinitesimals.

⁹ It is important to note that, formally, the unit of $\Delta T/\Delta V$ should be $hr/(mi/hr)$, but Sue evidently reasoned that $1/\Delta V$ ths of the total change in velocity should correspond to $1/\Delta V$ ths of the time in which the change in velocity occurred. Therefore each increment of the total time would be $\Delta T/\Delta V$ ths of one hour. This is the kind of reasoning about rates depicted in Figures 1 and 2.

¹⁰ In a later problem, "about how far does a rock fall on the moon in its fourth second of falling if on the moon falling things speed up at the rate of 6 ft/sec every second," Sue concluded that at the beginning of the fourth second the rock would be falling 18 ft/sec, and that each one-tenth of a second thereafter the rock would speed up by 0.6 ft/sec.

¹¹ A more accurate representation of the Riemann sum would be to have $[x/\Delta x]$, the greatest integer less than or equal to $x/\Delta x$, in the upper limit of the summation. However, our graphing program used the convention that the upper limit of a summation is truncated to an integer, so it was only necessary to put $x/\Delta x$ as the upper limit of the summation.

¹² My class presentations were with a Macintosh Powerbook connected to an LCD projection panel. I used Theorist, which allows expressions and functions to be displayed in standard mathematical notation and which allows graphs, diagrams, etc. to be placed anywhere on the computer screen. The function definitions and graphs presented here are taken directly from my class presentation.

¹³ See the discussion of Figure 3.

¹⁴ By an "accrual" to a Riemann sum I mean the thing whose measure is $f(t_i)\Delta t$. So by "constituent quantity" I mean the thing measured by $f(t_i)$ in $f(t_i)\Delta t$.

¹⁵ An antiderivative of $f(x)$ is a function $g(x)$ such that $g'(x) = f(x)$. Antidifferentiation is the process of finding an antiderivative.

REFERENCES

- Anton, H.: 1992, *Calculus with Analytic Geometry*, John Wiley and Sons, New York.
- Baron, M.: 1969, *The Origins of Infinitesimal Calculus*, Pergamon Press, New York.
- Boyd, B. A.: 1992, *The Relationship between Mathematics Subject Matter Knowledge and Instruction: A Case Study*, Masters Thesis, San Diego.
- Boyer, C. B.: 1959, *The History of the Calculus and Its Conceptual Development*, Dover, New York.
- Cobb, P. and von Glasersfeld, E.: 1983, 'Piaget's scheme and constructivism', *Genetic Epistemology* 13, 9–15.
- Courant, R.: 1937, *Differential and Integral Calculus*, Interscience, New York.
- Dewey, J.: 1929, *The Sources of a Science of Education*, Liveright Publishing, New York.
- Dubinsky, E.: 1991, 'Reflective abstraction in advanced mathematical thinking', in D. Tall (ed.), *Advanced Mathematical Thinking*, pp. 95–123, Kluwer, Dordrecht, The Netherlands.
- Goldenberg, E. P.: 1988, 'Mathematics, metaphors, and human factors: Mathematical, technical, and pedagogical challenges in the educational use of graphical representation of functions', *Journal of Mathematical Behavior* 7, 135–173.
- Hayes, J. R.: 1973, 'On the function of visual imagery in elementary mathematics', in W. G. Chase (ed.), *Visual Information Processing*, pp. 177–214, Academic Press, New York.
- Johnson, M.: 1987, *The Body in the Mind: The Bodily Basis of Meaning, Imagination, and Reason*, University of Chicago Press, Chicago, IL.
- Kaput, J. J.: in press, 'Democratizing access to calculus: New routes to old roots', in A. H. Schoenfeld (ed.), *Mathematics and Cognitive Science*, Mathematical Association of America, Washington, D.C.
- Kieren, T. and Pirie, S.: 1990, April, 'A recursive theory for mathematical understanding: Some elements and implications', Paper presented at the Annual Meeting of the American Educational Research Association, Boston, MA.
- Kieren, T. and Pirie, S.: 1991, 'Recursion and the mathematical experience', in L. P. Steffe (ed.), *Epistemological Foundations of Mathematical Experience*, pp. 78–101, Springer-Verlag, New York.
- Kieren, T. E.: 1989, 'Personal knowledge of rational numbers: Its intuitive and formal development', in J. Hiebert and M. Behr (eds.), *Number Concepts and Operations in the Middle Grades*, pp. 162–181, National Council of Teachers of Mathematics, Reston, VA.
- Kosslyn, S. M.: 1980, *Image and Mind*, Harvard University Press, Cambridge, MA.
- Kuhn, T. S.: 1970, 'Logic of discovery or psychology of research', in I. Lakatos and A. Musgrave (eds.), *Criticism and the Growth of Knowledge*, pp. 1–22, Cambridge University Press, Cambridge, U.K.
- Piaget, J.: 1950, *The Psychology of Intelligence*, Routledge and Kegan-Paul, London.
- Piaget, J.: 1967, *The Child's Concept of Space*, W. W. Norton, New York.
- Piaget, J.: 1968, *Six Psychological Studies*, Vintage Books, New York.
- Piaget, J.: 1971, *Genetic Epistemology*, W. W. Norton, New York.
- Piaget, J.: 1976, *The Child and Reality*, Penguin Books, New York.
- Piaget, J.: 1980, *Adaptation and Intelligence*, University of Chicago Press, Chicago.
- Pirie, S. and Kieren, T.: 1991, April, 'A Dynamic Theory of Mathematical Understanding: Some features and implications', Paper presented at the Annual Meeting of the American Educational Research Association, Chicago, IL.
- Sfard, A.: 1991, 'On the dual nature of mathematical conceptions: Reflections on processes and objects as different sides of the same coin', *Educational Studies in Mathematics* 22, 1–36.
- Steffe, L. P.: 1991, 'Operations that generate quantity', *Journal of Learning and Individual Differences* 3, 61–82.
- Steffe, L. P.: in press, 'Children's multiplying and dividing schemes: An overview', in G. Harel and J. Confrey (eds.), *The Development of Multiplicative Reasoning in the Learning of Mathematics*, SUNY Press, Albany, NY.

- Swokowski, E. W.: 1991, *Calculus*, PWS-Kent, Boston, MA.
- Tall, D.: 1986, *Building and Testing a Cognitive Approach to the Calculus Using Interactive Computer Graphics*, Doctoral dissertation, University of Warwick.
- Tall, D., Van Blokland, P., and Kok, D.: 1988, *A Graphic Approach to the Calculus*, Computer Program for IBM and Compatibles, Warwick University, Warwick, U.K.
- Tall, D. and Vinner, S.: 1981, 'Concept images and concept definitions in mathematics with particular reference to limits and continuity', *Educational Studies in Mathematics* 12, 151–169.
- Thompson, A. G. and Thompson, P. W.: in press, 'Talking about rates conceptually: A teacher's struggle', *Journal for Research in Mathematics Education*.
- Thompson, P. W.: 1985, 'Experience, problem solving, and learning mathematics: Considerations in developing mathematics curricula', in E. Silver (ed.), *Teaching and Learning Mathematical Problem Solving: Multiple Research Perspectives*, pp. 189–243, Erlbaum, Hillsdale, NJ.
- Thompson, P. W.: 1991, 'To experience is to conceptualize: Discussions of epistemology and experience', in L. P. Steffe (ed.), *Epistemological Foundations of Mathematical Experience*, pp. 260–281, Springer-Verlag, New York.
- Thompson, P. W.: in press a, 'The development of the concept of speed and its relationship to concepts of rate', in G. Harel and J. Confrey (eds.), *The Development of Multiplicative Reasoning in the Learning of Mathematics*, SUNY Press, Albany, NY.
- Thompson, P. W.: in press b, 'Students, functions, and the undergraduate mathematics curriculum', *Research in Collegiate Mathematics Education* 1.
- Thompson, P. W. and Thompson, A. G.: 1992, April, 'Images of rate', Paper presented at the Annual Meeting of the American Educational Research Association, San Francisco, CA.
- Vinner, S.: 1987, 'Continuous functions: Images and reasoning in college students', in *Proceedings of the Annual Meeting of the International Group for the Psychology of Mathematics Education*, PME Montréal, Canada.
- Vinner, S.: 1989, 'Avoidance of visual considerations in calculus students', *Journal of Mathematical Behavior* 11, 149–156.
- Vinner, S.: 1991, 'The role of definitions in the teaching and learning of mathematics', in D. Tall (ed.), *Advanced Mathematical Thinking*, pp. 65–81, Kluwer, Dordrecht, The Netherlands.
- Vinner, S.: 1992, 'The function concept as a prototype for problems in mathematics learning', in G. Harel and E. Dubinsky (eds.), *The Concept of Function: Aspects of Epistemology and Pedagogy*, pp. 195–214, Mathematical Association of America, Washington, D.C.
- Vinner, S. and Dreyfus, T.: 1989, 'Images and definitions for the concept of function', *Journal for Research in Mathematics Education* 20, 356–366.
- von Glasersfeld, E.: 1978, 'Radical constructivism and Piaget's concept of knowledge', in F. B. Murray (ed.), *Impact of Piagetian Theory*, pp. 109–122, University Park Press, Baltimore.
- Wilder, R.: 1967, 'The role of axiomatics in mathematics', *American Mathematical Monthly* 74, 115–127.
- Wilder, R.: 1968, *Evolution of Mathematical Concepts: An Elementary Study*, Wiley, New York.
- Wilder, R.: 1981, *Mathematics as a Cultural System*, Pergamon Press, New York.
- Winograd, T. and Flores, F.: 1986, *Understanding Computers and Cognition: A New Foundation for Design*, Ablex, Norwood, NJ.

Patrick W. Thompson,
 Center for Research in
 Mathematics and Science Education
 San Diego State University,
 6475 Alvarado Rd. #206,
 San Diego, CA 92120, USA