

Level One Representations of the Simple Affine Kac-Moody Algebras in Their Homogeneous Gradations

Denis Bernard and Jean Thierry-Mieg*

Groupe d'Astrophysique Relativiste, CNRS, Observatoire de Paris-Meudon,
F-92195 Meudon, France

Abstract. Using the central charge of the Virasoro algebra as a clue, we recall the known constructions of the A , D , E algebras and discuss new Bosonic constructions of the non simply laced affine Kac-Moody algebras: the twisted A , D , E and the B , C , F , and G algebras. These involve interacting Fermions and a generalization of the Frenkel-Kac sign operators which do not form a 2-cocycle when the horizontal algebra has more than one short simple root.

Contents

Introduction	182
A. Tools	183
A.1. Classification of Kac-Moody Algebras	183
A.2. The Virasoro Algebra and Its Unitary Representations	194
A.3. Application: The $A_1^{(1)}$ Algebra	198
A.4. Two-Dimensional Conformally Invariant Q.F.T. and Algebras.	201
B. Free Field Constructions	208
B.1. $K=1$ Representations of $A_1^{(1)}$	208
B.2. $K=1$ Representations of the Simply Laced Algebras	210
B.3. $K=1$ Representations of $B_n^{(1)}$	212
B.4. $K=1$ Representations of $D_{n+1}^{(2)}$, First Construction	215
B.5. Fermionic Constructions of the Twisted Algebras $A_\ell^{(2)}$, $D_{2\ell+1}^{(2)}$, and $E_6^{(2)}$	216
B.6. Bosonic Constructions of the Twisted Algebras $A_{2\ell-1}^{(2)}$, $D_{\ell+1}^{(2)}$, and $E_6^{(2)}$	219
B.7. Bosonic Construction of the Twisted Algebra $A_{2\ell}^{(2)}$	223
B.8. Two Constructions of $D_4^{(3)}$	224
C. Interacting Field Constructions.	228
C.1. Construction of the Auxiliary Virasoro Algebras.	229
C.2. Representations of $A_1^{(1)}$ of Arbitrary Level.	231
C.3. $K=1$ Representations of $B_\ell^{(1)}$, $G_2^{(1)}$, and $A_2^{(2)}$	233
C.4. $K=2$ Representations of $A_\ell^{(1)}$, $D_\ell^{(1)}$, and $E_\ell^{(1)}$	235
C.5. $K=1$ Representations of $F_4^{(1)}$ and $C_\ell^{(1)}$	237
D. Character Identities	238

* Address from 9-86 to 8-88: DAMTP, Silver Street, Cambridge, England

Conclusion	242
Appendix: The Chevalley Structure Constants.	243
References.	244

Introduction

The theory of affine Kac-Moody algebras [1, 2] once more illustrates the conspiracy of mathematics and physics. It appeared in the late sixties, in mathematics with the abstract classifications of Kac [3] and Moody [4], and in physics with the development of current algebra [5], string theory [6], and the discovery of the Virasoro algebra [7].

During the seventies, the theory underwent a slow but steady development with several landmarks: in physics, the discovery of the superstring by Neveu-Schwarz and Ramond [8], the first construction of Kac-Moody modules (the level one representation of the untwisted affine unitary and orthogonal algebras) by Bardakci and Halpern [9], and the understanding of the boson-fermion correspondence [9, 10]; in mathematics, the generalization by Kac of the Weyl character formula [11] and his analysis of the Verma module representations of the Virasoro algebra [12].

These two currents merged in 1980 when Lepowski and Wilson [13], Frenkel and Kac [14], and Segal [15], realized that the tachyon emission vertex operator of the Veneziano model can be used to represent the simply laced affine Kac-Moody algebras of level one.

Soon afterwards, Kac, Kazhdan, Lepowski, and Wilson [16] generalized the principal construction to all the A , D , E affine algebras, and Frenkel [17] and Witten [18] gave a new impetus to the boson-fermion correspondence.

Since, the theory of Kac-Moody algebras has become a major focus of interest in mathematics and physics, with applications in arithmetic, partial differential equations, statistical mechanics, and quantum field theory. Implicit in the early years, the modular group plays a central role in the two most impressive recent realizations: the construction of the moonshine module [19] and of the heterotic string theory [20].

A recent bibliography has been compiled by Benkart [21], and in the books of Kac [1] and of Schwarz [22].

The aim of this study is to review the theory of affine Kac-Moody algebras in a language accessible to the physicists and to solve a vexing riddle: the generalization of the Bosonic construction of Frenkel, Kac, and Segal to the non-simply laced algebras $A-D-E$ twisted, $B-C-F$, and G . The analysis of the associated Virasoro algebra is the key of our constructions.

Our paper is organized as follows. Chapter A provides a self contained introduction to affine Kac-Moody algebras. In Sect. A.1, which closely follows the notations of Kac [1], we classify the Kac-Moody algebras and study their gradations. In Sect. A.2, we introduce the associated Virasoro algebra, summarize the theory of its representations, and study in detail the energy of the vacuum. In Sect. A.3, we illustrate these considerations on the simple case of the algebra $A_1^{(1)}$. Section A.4 introduces the methods of quantum field theory, current algebra, and operator product expansions. Very many formulae, which will be continuously used in the sequel, are gathered in this chapter.

Chapter B describes the constructions of Kac-Moody modules such that the central charge of the associated Virasoro algebra is integral. We define two classes of constructions: bosonic and fermionic. In the bosonic, the Hilbert space carrying the representation is the Fock space of a set of free bosonic oscillators in one to one correspondence with the imaginary roots, tensored by the weight lattice of the horizontal algebra. By the theorem of Goddard, Kent, and Olive [23] this space is large enough, since the central charge of the Virasoro algebra is equal to the sum of the degeneracies of the imaginary roots. We prove irreducibility. The Frenkel-Kac construction [14] is recalled in Sects. B.1 and B.2 and generalized to the twisted algebras in Sects. B.4 and B.6–B.8. In the fermionic construction of the twisted algebras $g^{(\epsilon)}$, Sects. B.5 and B.8, the bosonic fields are averaged over an outer automorphism of g without fixed point. Hence, they lose their zero modes, and the weight lattice of the horizontal algebra is replaced by a finite dimensional spinor. The signs are provided by a system of generalized Dirac matrices. These constructions appear in Lepowski [24] and implicitly in Kac and Peterson [25].

Chapter C deals with modules such that the central charge of the Virasoro algebra is not integral. We rely on the methods of quantum field theory. Extending the results of Eguchi and Higashijima [26], we define in Sect. C.1 two complementary stress-tensors built upon the root system of an algebra of type A, D, E , and construct their primary fields which behave as generalized interacting fermions [27]. In the following sections, we use these fields to complete the vertex operators of the level two modules of A, D, E , and the level one modules of the affine algebra of type C, F , and G . These constructions are irreducible only as $(\text{Virasoro})' * (\text{Kac-Moody})''$ modules, where $(\text{Virasoro})''$ is one of the complementary stress-tensors.

The bosonic constructions of Chaps. B and C involve the ϵ operators, first considered by Frenkel and Kac [14], which map the square of the root lattice of the horizontal algebra g_0 onto $\{-1, +1\}$. When g_0 is of type A, B, D, E , and G , the ϵ form a two-cocycle, however, when g_0 has more than one simple short root (type C and F) they do not. Modified ϵ are defined in Sect. B.6. They only depend on g_0 , and we use the same ϵ in the constructions of Chaps. B and C even though the currents are very different.

Chapter D describes some amusing manipulations which illustrate the enormous symmetry of the affine Kac-Moody algebras.

A. Tools

A.1. Classification of Kac-Moody Algebras

Following the book of Kac [1], we recall in this section the main definitions and properties that we shall need throughout our discussion.

Consider an integral $(r + 1) * (r + 1)$ square matrix a_{ij} , called the Cartan matrix, satisfying the conditions:

$$\left. \begin{aligned} a_{ii} = 2, \quad a_{ij} \leq 0, \quad i \neq j, \\ a_{ij} = 0 \Rightarrow a_{ji} = 0. \end{aligned} \right\} \tag{A1-1}$$

The Kac-Moody algebra $g(a)$ is the Lie algebra generated by the $3(r + 1)$ elements,

$$\{h_i, e_i^+, e_i^-\}, \quad i = 0, 1, \dots, r,$$

satisfying the relations:

$$\begin{aligned}
 [h_i, h_j] &= 0, \\
 [h_i, e_j^\pm] &= \pm a_{ij} e_j^\pm, \\
 [e_i^+, e_j^-] &= \delta_{ij} h_j, \\
 (\text{Ad } e_i^\pm)^{1-a_{ij}} e_j^\pm &= 0,
 \end{aligned}
 \tag{A1-2}$$

and the Jacobi identity.

One should distinguish three cases:

i) Finite case. The Cartan matrix is invertible. Then, we shall prove that the algebra is one of the finite dimensional simple Lie algebras classified by Killing and Cartan.

ii) Tamed case. The Cartan matrix is of rank r . Then, the algebra is called an affine Kac-Moody algebra. It is infinite dimensional but not too difficult to study. The aim of our paper is to construct explicitly the “simplest” highest weight unitarizable representations of these algebras.

iii) Wild case. The Cartan matrix is of lower rank. Very little is known so far in this case although the lorentzian algebra E_{10} , which belongs to this family, is undoubtedly of great interest, to mathematicians and physicists alike.

The maximal commuting subalgebra H generated by the h_i is called the Cartan subalgebra. Its dual vector space H^* is the root space. To every generator e_i^\pm , we associate a vector α_i of H^* , called a simple root, by the relation:

$$\alpha_i(h_j) = a_{ji}.
 \tag{A1-3}$$

All information specific of a particular Kac-Moody algebra is coded in its Cartan matrix. It is very convenient to describe this matrix via its Dynkin diagram defined as follows:

i) to each simple positive root α_i associate a vertex,



ii) join every pair of vertices by $\max(|a_{ij}|, |a_{ji}|)$ lines, with an arrow pointing from i to j if $|a_{ij}| < |a_{ji}|$.

Two Cartan matrices which differ by the ordering of their index sets have the same diagram; they generate isomorphic algebras. If the Cartan matrix is indecomposable, the diagram is connected and vice versa. We restrict our attention to this case. If a Cartan matrix is not symmetric, the transposed matrix is also a Cartan matrix; its Dynkin diagram is obtained by reversing all the arrows of the original diagram.

Let us first consider the lowest ranks.

a) The unique rank-one simple Lie algebra is $A_1 = \text{su}(2)$: $a_{11} = 2$.

b) By inspection there exist three indecomposable regular Cartan matrices corresponding to the finite dimensional algebras:

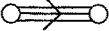
A_2	$a = \begin{bmatrix} 2 & -1 \\ -1 & 2 \end{bmatrix}$	
$B_2 = C_2$	$a = \begin{bmatrix} 2 & -1 \\ -2 & 2 \end{bmatrix}$	
G_2	$a = \begin{bmatrix} 2 & -1 \\ -3 & 2 \end{bmatrix}$	

and two tamed matrices corresponding to the affine algebras:

$$\begin{array}{ll}
 A_1^{(1)} & a = \begin{bmatrix} 2 & -2 \\ -2 & 2 \end{bmatrix} \\
 A_2^{(2)} & a = \begin{bmatrix} 2 & -1 \\ -4 & 2 \end{bmatrix}
 \end{array}$$

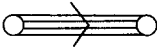
In higher rank, since every rank two subalgebra must be of finite type, the off-diagonal entries of the Cartan matrix satisfy the strong condition:

$$\text{if } r \geq 2, \quad i \neq j \quad \left\{ \begin{array}{l} \text{either } a_{ij} = a_{ji} = 0, \\ \text{or } \begin{cases} \min(-a_{ij}, -a_{ji}) = 1, \\ \max(-a_{ij}, -a_{ji}) \leq 3, \end{cases} \end{array} \right.$$

which shows that affine Dynkin diagrams and Cartan matrices are in one to one correspondence.

Since the rows of the Cartan matrix are linearly dependent, we can associate to each simple root α_i its Kac label k_i , and its dual Kac label k_i^\vee , defined by:

$$\min(k_i) = \min(k_i^\vee) = 1, \tag{A1-4}$$

$$\sum_{j=0}^r a_{ij} k_j = \sum_{j=0}^r k_j^\vee a_{ji} = 0.$$

The sums:

$$h = \sum_{i=0}^r k_i, \quad h^\vee = \sum_{i=0}^r k_i^\vee \tag{A1-5}$$

play an important role in the theory; they are called the Coxeter and dual Coxeter numbers of the algebra. Diagrammatically, every Kac label k_i is equal to half the sum of its neighbours k_j in the Dynkin diagram, weighted by the number of lines if j is on the larger side of an arrow.

By construction, the Cartan generator

$$k = \sum_{i=0}^r k_i^\vee h_i \tag{A1-6}$$

commutes with all the generators of the algebra, and hence with the whole algebra. It is called the central element, or central charge. Since the kernel of $[a]$ is one dimensional, this element is unique.

The classification of the affine Dynkin diagrams is now extremely easy. It is actually easier than the classification of the finite diagrams (which follows as a consequence) because an affine diagram cannot appear as a subdiagram of a larger one and because of the existence of a Kac labelling. Following these two rules, one immediately derives the classification given in Tables 1–3 where, for future convenience, the algebra are sorted according to their twist. By deleting a vertex, one recovers the finite diagrams shown in Table 4 [3, 4].

Let us now associate to each algebra a symmetric matrix g_{ij} satisfying:

$$\begin{aligned}
 g_{ij} &= g_{ji}, \\
 g_{ij} &= \lambda_i a_{ij}, \quad \lambda_i > 0,
 \end{aligned} \tag{A1-7a}$$

Table 1-3. Dynkin diagrams of the simple affine Kac-Moody algebras sorted according to their twist τ . Each diagram has $(\ell + 1)$ vertices. The numbers on the diagrams are the Kac labels k_i (A1-4)

Table 1

$\tau=1$: untwisted affine algebras

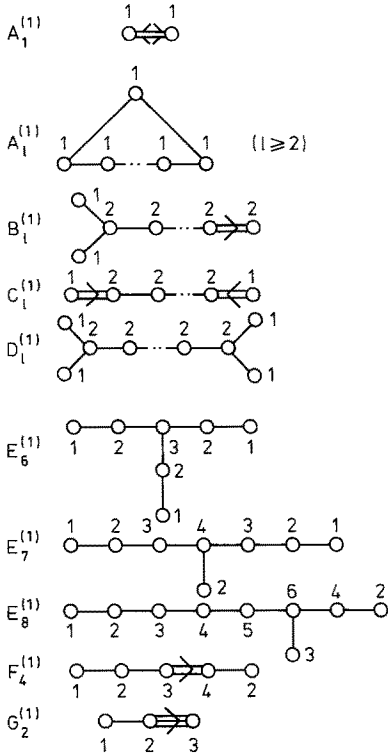

Table 2

$\tau=2$: 2-twisted affine algebras

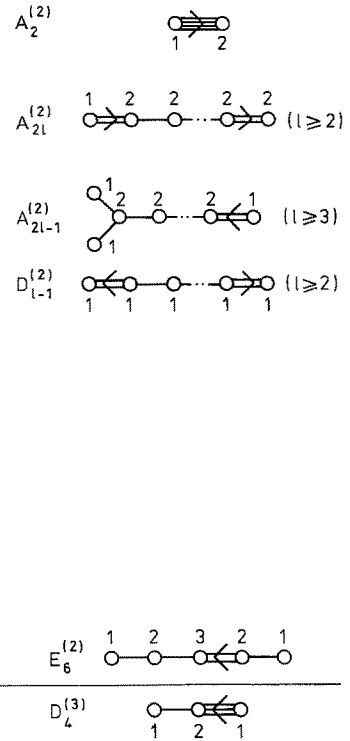

Table 3

$\tau=3$: 3-twisted affine algebras

and the normalization:

$$\max(g_{ii})=2.$$

This is always possible, since either the Cartan matrix is symmetric, or the Dynkin diagram contains no cycle. In the first case, called simply laced, we choose $g_{ij}=a_{ij}$. In the latter case, we start from the largest vertex, as indicated by the arrows of the diagram, and we symmetrize recursively. By inspection, we observe that:

$$\lambda^{-1}_i=1, 2, 3 \text{ or } 4. \tag{A1-7b}$$

The matrix g_{ij} defines a degenerate metric on the root space H^* [with long roots normed to $(\alpha, \alpha)=2$] through:

$$(\alpha_i, \alpha_j)=g_{ij}. \tag{A1-8}$$

Table 4. Dynkin diagrams of the simple finite dimensional Lie algebras (A1-4)

A_l	
B_l	
C_l	
D_l	
E_6	
E_7	
E_8	
F_4	
G_2	

In terms of this scalar product, the Cartan matrix can be written as:

$$a_{ij} = 2 \frac{(\alpha_i, \alpha_j)}{(\alpha_i, \alpha_i)}. \tag{A1-9}$$

The dual metric g_{ij}^\vee , which can be derived from the dual Dynkin diagram with short roots scaled to $(\alpha, \alpha)^\vee = 2$, defines a metric on H :

$$(h_i, h_j)^\vee = g_{ij}^\vee = 4 \frac{(\alpha_i, \alpha_j)}{(\alpha_i, \alpha_i)(\alpha_j, \alpha_j)}. \tag{A1-10}$$

The central charge k is a null vector for this metric:

$$(k, k)^\vee = \sum_{i,j} k_i g_{ij}^\vee k_j = 0, \tag{A1-11}$$

whereas there exists a root δ which is the null vector with respect to the metric g_{ij} :

$$(\delta, \delta) = 0, \quad \delta = \tau \sum_{i=0}^r k_i \alpha_i, \tag{A1-12}$$

where τ , the twist, is number of the Tables 1–3, where the diagram appears.

Because of these degeneracies, H and H^* are not dual to each other metricwise. It is therefore very interesting to introduce a new Cartan operator, denoted by d or L_0 , called the derivation or energy operator, and a new element A_0 of H^* , dual to the central element k . A_0 is called the highest weight of the basic representation.

$$\begin{aligned} \delta(k) &= 0, & A_0(k) &= 1, \\ \delta(d) &= 1, & A_0(d) &= 0. \end{aligned} \tag{A1-13}$$

The metric on H and H^* are extended to:

$$\begin{aligned} (d, d)^\vee &= 0, & (A_0, \delta) &= \tau, \\ (d, k)^\vee &= \frac{1}{\tau}, & (A_0, A_0) &= 0. \end{aligned} \tag{A1-14}$$

There remains, however, a great arbitrariness in the choice of the quantities

$$\alpha_i(d) = (d, h_i)^\vee = ?$$

which define recursively a gradation of the root space. Throughout this paper, we shall work in the homogeneous gradations that we define as follows:

- *) Call α_0 a root such that its Kac label is $k_0 = 1$.
- *) Delete this root; the remaining subdiagram generates a finite Lie algebra, called the horizontal algebra g_0 (see Table 5).
- *) The gradation is then defined by the relation:

$$[d, g_0] = 0, \tag{A1-15}$$

which implies that, $\alpha_i(d) = 0$ for $i = 1$ to r , and its dual counterpart, $A_0(h_i) = 0$ for $i = 1$ to r . The metrics on H and H^* are then completed by the definition

$$(h_i, d)^\vee = (A_0, \alpha_i) = 0, \tag{A1-16}$$

and can be extended to the whole algebra g .

Table 5. Decompositions of the Lie algebra g under the automorphisms σ of order τ corresponding to the homogeneous gradations of $g^{(r)}$ (A1-25)

g	τ	g_0	g_1	g_2	$\dim(g_1)$
A_{2n}	2	B_n			$n(2n + 3)$
A_{2n-1}	2	D_n			$2n^2 + n - 1$
		C_n			$2n^2 - n - 1$
D_{n+1}	2	$B_m \oplus B_{n-m}$	(\square, \square)		$(2m + 1)(2n - 2m + 1)$
E_6	2	C_4			42
		F_4			26
D_4	3	A_2			10
		G_2			7

Our definitions (A1-12) through (A1-16) differ from those of Kac [1]. In our notations the roots of the untwisted affine subalgebra of the twisted algebra are normalized exactly as in the untwisted affine algebra [thanks to the factor τ in (A1-12)]. Furthermore, if the Kac-Moody algebra is of type $g^{(\tau)}$, the automorphism σ which centralizes g_0 in g is of order τ (this is not the case for $A_{2\ell}^{(2)}$ in Kac, driving him into several complications).

The twisted algebras $A_{2\ell-1}^{(2)}$, $E_6^{(2)}$, and $D_4^{(3)}$ admit 2 homogeneous gradations, the $D_{\ell-1}^{(2)}$ several. We shall construct the level one representations of these algebras in each of these gradations.

A gradation can actually be associated to each conjugacy class of the Weyl group of g (112 in the case of E_8 [25]). Our homogeneous gradations correspond, in the untwisted case, to the class of the identity. The principal gradation, which is such that $\alpha_i(d) = 1/h$ for all the simple roots of g , corresponds to the class of the Coxeter element.

Geometrically, a modification of the gradation corresponds to a modification of the horizontal direction in the root space, see Figs. 1 and 2.

If we extend the Dynkin diagram of g according to (A1-13)–(A1-16), we obtain the over-extended Dynkin diagram with a single additional node connected to the root α_0 . The corresponding Cartan matrix is lorentzian, with one time and $r+1$ spatial directions (signature $-++++\dots$). As emphasized by Goddard and Olive [28], d corresponds, in the relativistic language, to the momentum of a photon, k to the conjugate null direction, and h^i to its transverse polarization.

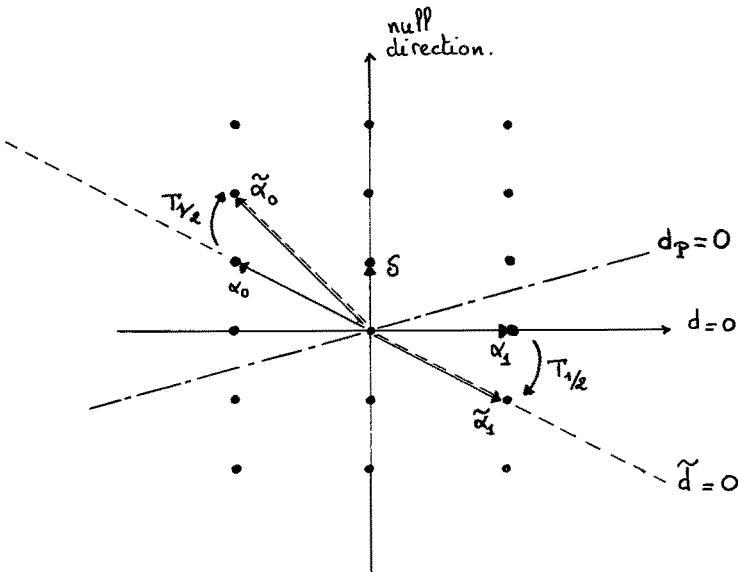

Fig. 1. Root diagram of the algebra $A_1^{(1)}$ (A1-13). (α_0, α_1) and $(\tilde{\alpha}_0, \tilde{\alpha}_1)$ are 2 systems of simple roots of $A_1^{(1)}$. δ is the null root. δ points in the null direction, but the dual direction $d=0$ can be chosen at will. Three examples are illustrated. d and \tilde{d} correspond to the 2 possible homogeneous gradations. They are exchanged by the outer automorphism $T_{1/2}$. d_p corresponds to the principal gradation

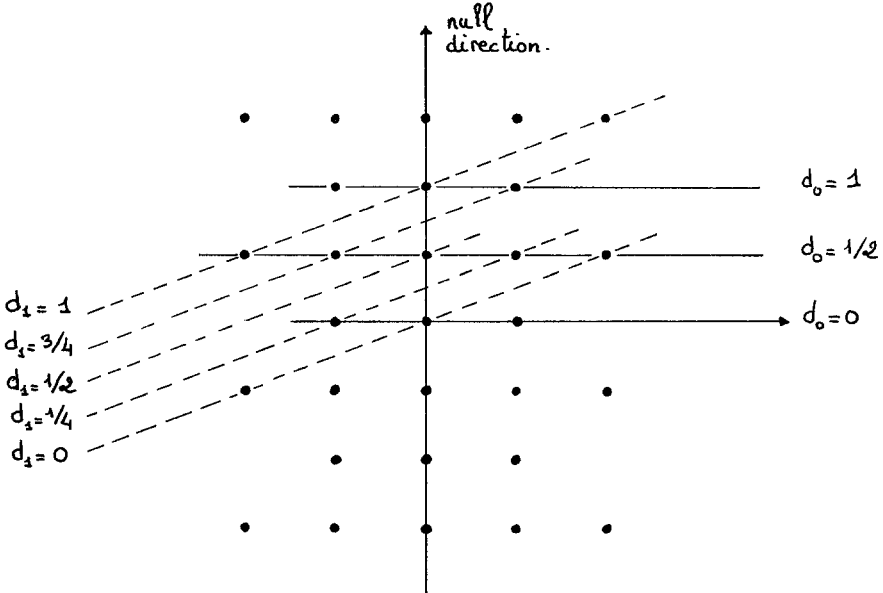

Fig. 2. Root diagram of the algebra $A_2^{(2)}$ (A1-30). The d_0 gradation corresponds to the outer automorphism of order 2 of A_2 , the d_1 gradation, to the automorphism of order 4

The Weyl group of $g(a)$ is the discrete group generated by the reflections R_i in the simple roots α_i :

$$R_i: H^* \rightarrow H^*, \tag{A1-17}$$

$$\lambda \rightarrow \lambda - 2 \frac{(\lambda, \alpha_i)}{(\alpha_i, \alpha_i)} \alpha_i.$$

This group is infinite and contains an abelian subgroup T isomorphic, in the simply laced case, to the root lattice of the horizontal subalgebra. The null root δ is Weyl invariant. The Weyl orbit of a real root has unbounded d -eigenvalues. However, since the metric on H^* is Weyl invariant by construction, the orbit of a weight A of level $k(A)=k$ lies on the paraboloid

$$P(A) = \{ \alpha + n\delta + kA_0, \alpha \in H_0^*, (\alpha, \alpha) + 2\tau nk = (A, A) \},$$

which is d -bounded from above if $k > 0$. The structure of the Weyl group will be more detailed, in the particular case of $A_1^{(1)}$, in Sect. A3.

Let us now give a realization of the untwisted and twisted algebras, describe explicitly their root systems and prove that our classification (see Table 4) of the finite Kac-Moody algebras is complete.

a) In the untwisted case, the Kac-Moody algebras can be realized as the central extension of the algebra $L(g_0)$ of the periodic map from the circle into the Lie algebra g_0 . Let $C[t, t^{-1}]$ be the algebra of Laurent polynomials in t , and $L(g_0)$ be the algebra $C[t, t^{-1}]g_0$ with the bracket

$$[t^m \otimes T^a, t^n \otimes T^b] = t^{m+n} \otimes [T^a, T^b]. \tag{A1-18}$$

The affine algebra is the algebra

$$\hat{g} = L(g_0) \oplus \mathbb{C}k \oplus \mathbb{C}d \tag{A1-19}$$

with the brackets:

$$\begin{aligned} [k, d] &= [k, t^m \otimes T^a] = 0, \\ [d, t^n \otimes T^a] &= -nt^n \otimes T^a, \\ [t^m \otimes T^a, t^n \otimes T^b] &= t^{m+n} \otimes [T^a, T^b] + mk(T^a, T^b)^\vee \delta_{m+n, 0}, \end{aligned} \tag{A1-20}$$

where $(T^a, T^b)^\vee$ is the standard Killing metric on g_0 .

Introducing the Chevalley basis of the algebra g_0 , and its structure constant $f(\alpha, \beta)$ [$f(\alpha, \beta) = \pm 1$ only in the cases A, D, B, E , and G], the commutation relations (A1-20) can be written as:

$$[t^m \otimes e_\alpha, t^n \otimes e_\beta] = \begin{cases} f(\alpha, \beta)t^{m+n} \otimes e_{\alpha+\beta} & \text{if } \alpha + \beta \text{ is a root of } g_0, \\ 0 & \text{if not,} \\ t^{m+n} \otimes h_\alpha + \frac{2m}{(\alpha, \alpha)} k \delta_{m+n, 0} & \text{if } \alpha + \beta = 0, \end{cases} \tag{A1-21}$$

$$\begin{aligned} [t^m \otimes h, t^n \otimes h'] &= m(h, h')^\vee k \delta_{m+n, 0}, \\ [t^m \otimes h, t^n \otimes e_\alpha] &= \alpha(h)t^{m+n} \otimes e_\alpha, \\ [d, k] &= 0. \end{aligned} \tag{A1-22}$$

It follows that the simple roots are the simple roots of the horizontal algebra completed by the root $(\delta - \phi)$, where ϕ is the highest root of the algebra g_0 . (The Cartan matrices of these simple root systems are effectively those of Table 1.) The roots of the untwisted algebra are then

$$\Delta = \{\alpha + n\delta, n \in \mathbb{Z}\} \cup \{n\delta, n \in \mathbb{Z}\}, \tag{A1-23}$$

where α is a root of the horizontal algebra. The roots, $\alpha + n\delta$, have positive norm and are called real roots. They are non-degenerate. The roots, $n\delta$, are r -times degenerate and have zero norm. They are called imaginary or null roots.

In this way, to any finite dimensional Kac-Moody algebra we can associate an untwisted affine algebra. Its Dynkin diagram must appear in Table 1; thus we prove that the classification given in Table 4 is complete.

b) The twisted algebras are associated to the outer-automorphism of the simple Lie algebras. Indeed, given a finite order automorphism of a Lie algebra g , say σ with $\sigma^M = 1$, one can define a gradation of the algebra g as:

$$g = \bigoplus_{\bar{k} \in \mathbb{Z}_M} g_{\bar{k}}, \quad [g_{\bar{k}}, g_{\bar{l}}] \subset g_{\overline{k+\bar{l}}}, \tag{A1-24}$$

where g_j is the eigenspace of σ for the eigenvalue $\omega^j = \exp(i2\pi j/M)$. The g_0 component is a Lie algebra. The $g_j, j > 0$, are representations of the g_0 algebra. It is possible to define a loop algebra $L(g, \sigma)$ associated to this automorphism by :

$$L(g, \sigma) = \bigoplus_{n \in \mathbb{Z}} (t^n \otimes g_{\bar{n}}). \tag{A1-25}$$

The affine algebra is then defined by the generalization of Eqs. (A 1-19) and (A 1-20). However, inner-automorphisms generate isomorphic algebras. Therefore, the twisted algebras are only related to the conjugacy classes of outer-automorphisms. These classes are isomorphic to the symmetries of the Dynkin diagram of g , which exist only in the cases A_ℓ, D_ℓ, E_6 . The g_0 algebras, the g_j representations and the order of the automorphism are listed in Table 5. The Dynkin diagram of g_0 is obtained by deleting from the Dynkin diagram of $g^{(\nu)}$ a node α_i with Kac label 1. The Dynkin weights of the g_0 -representation g_1 are equal, up to a rescaling, to the i^{th} line of the Cartan matrix of $g^{(\nu)}$ [compare with (A 1-9) and (A 1-35)]. It is easy to verify that a system of simple roots can be chosen to be the simple roots of the horizontal algebra g_0 together with the root $(\delta - \theta)$, where θ is the highest weight of the representation g_1 . As expected, the Cartan matrices of these root systems are those given in Tables 2 and 3. The Kac labels come from the decomposition of θ on the simple roots of g_0 .

The root diagram follows from this realization. Let $\Delta(g_0)$ denote the root system of g_0 and $\Delta(g_1)$ the non-zero weights of the g_0 -representation g_1 . The real roots of the twice twisted algebras are

$$\Delta^{re} = \{ \Delta(g_0) + \mathbb{Z}\delta \} \cup \{ \Delta(g_1) + (\mathbb{Z} + \frac{1}{2})\delta \}. \tag{A1-26}$$

They are non-degenerate. The imaginary roots are

$$\Delta^{im} = \{ \frac{1}{2}m\delta, m \in \mathbb{Z} \}. \tag{A1-27}$$

Their degeneracy is $\text{rank}(g_0)$ if m is even, and it is $(\text{rank}(g) - \text{rank}(g_0))$ if m is odd. Similarly, for $D_4^{(3)}$ the real roots are, in the homogeneous gradation with $g_0 = G_2$:

$$\Delta^{re} = \{ \alpha + \mathbb{Z}\delta, \alpha \in \Delta(G_2) \} \cup \{ \omega + (\mathbb{Z} \pm \frac{1}{3})\delta, 0 \neq \omega \in \mathcal{I} \text{ of } G_2 \} \tag{A1-28a}$$

or, in the homogeneous gradation with $g_0 = A_2$:

$$\begin{aligned} \Delta^{re} = & \{ \alpha + \mathbb{Z}\delta, \alpha \in \Delta(A_2) \} \\ & \cup \{ \omega + (\mathbb{Z} + \frac{1}{3})\delta, 0 \neq \omega \in \mathcal{I} \} \\ & \cup \{ \omega + (\mathbb{Z} - \frac{1}{3})\delta, 0 \neq \omega \in \overline{\mathcal{I}} \}. \end{aligned} \tag{A1-28b}$$

In both gradations, the imaginary roots are

$$\Delta^{im} = \{ \frac{1}{3}m\delta, m \in \mathbb{Z} \} \tag{A1-29}$$

with multiplicity equal to one if $m \neq 0 \pmod 3$ and to two if $m = 0 \pmod 3$. As in Figs. 1 and 2, the distinction between (A 1-28 a) and (A 1-28 b) corresponds to two choices of the horizontal direction in the same root diagram.

In Sect. C, we shall construct the level one representations of $A_{2\ell}^{(2)}$ in another gradation, corresponding to an outer-automorphism of order four of $A_{2\ell}$. The new horizontal algebra is the symplectic algebra C_ℓ . The relation between these two gradations is illustrated in Fig. 2, in the particular case of $A_2^{(2)}$. The $A_{2\ell}$ algebra decomposes with respect to this non-regular symplectic subalgebra as:

$$A_{2\ell} = (C_\ell)_0 + (\square)_1 + (\boxtimes + \bullet)_2 + (\square)_3. \tag{A1-30}$$

The real root system is then described by:

$$\Delta^{re} = \{ \frac{1}{2}\alpha_\ell + (\mathbb{Z} + \frac{1}{2})\delta \} \cup \{ \alpha_s + \frac{1}{2}\mathbb{Z}\delta \} \cup \{ \alpha_\ell + \mathbb{Z}\delta \}, \tag{A1-31}$$

where α_ℓ and α_s are the long and short roots of the C_ℓ algebra. The simple roots can be chosen to be the simple roots of C_ℓ and the root $(\delta - \theta)$ where θ is now the highest weight of the \square representation. This description $A_{2\ell}^{(2)}$ is the one used in the book of Kac [1].

It remains to be shown that every Kac-Moody algebra admits a unique Dynkin diagram, or equivalently, that the algebras corresponding to different Dynkin diagrams are not isomorphic. This follows from the fact that two distinct diagrams never have at the same time the same rank and the same Coxeter number.

Now consider the base A_i of H^* dual to the h_i :

$$A_i(h_j) = \delta_{ij}, \quad i, j = 0, 1, \dots, r. \tag{A1-32}$$

Their sum ϱ is the Weyl vector, usually defined in the finite case as the half sum of the positive roots. Again we need to specify

$$\Delta_i = A_i(d). \tag{A1-33}$$

A natural choice for these numbers will be given in Sect. A3. The A_i are called the fundamental weights. A vector A of H^* is called an integral weight if its contravariant components δ_i on the A_i basis are integers:

$$A = \sum \delta_i A_i, \quad A(h_i) = \delta_i \in \mathbb{Z}^+. \tag{A1-33}$$

The δ_i are called the Dynkin weights of A . They are used to label an important class of linear representations of the Kac-Moody algebra.

We consider, in a vector space \mathcal{H} , a vector $|A\rangle$ satisfying:

$$\begin{aligned} h_i |A\rangle &= \delta_i |A\rangle, \\ e_i^+ |A\rangle &= 0, \\ d |A\rangle &= \Delta |A\rangle. \end{aligned} \tag{A1-35}$$

The Verma module $V(A)$ is the linear span of the vectors obtained by repeated action of the negative generators e_i^- on $|A\rangle$. This space, carries a representation, usually reducible, of the Kac-Moody algebra, which is called a highest weight vector representation. The action of every generator follows from the definition (A1-35) and the commutation relations (A1-2).

It is well known that the only unitarizable highest weight representations of the finite Lie algebras have non-negative integral Dynkin weights. This condition is necessary also in the Kac-Moody algebras, since each δ_i is the Dynkin weight corresponding to the A_1 subalgebra $(h_i; e_i^+; e_i^-)$. According to Kac [1, Chaps. 9 and 11], the condition is sufficient. As a consequence, the eigenvalue k of the central element of the algebra, called the level of the representation, is also a positive integer

$$\begin{aligned} k |A\rangle &= \sum_{i=0}^r k_i \check{h}_i |A\rangle, \\ k = A(k) &= \sum_{i=0}^r \delta_i k_i \check{.} \end{aligned} \tag{A1-36}$$

By abuse of notation, we denote by the same symbol, k , the central element and its value in a given representation.

Note that $E_8^{(1)}$, $E_6^{(2)}$, and $D_4^{(3)}$ have a unique level one representation, whereas $D_4^{(1)}$ has four: called the scalar, vector and the two spinors, by the name of the representation of the horizontal subalgebra D_ℓ .

It is very important to note that the level of a representation is intrinsically defined, whereas the definition of g_0 , and hence the name of the representation, depends on the choice of the derivation operator, or Virasoro operator ($L_0 = d$). In the principal gradation, the 4 level one modules of $D_\ell^{(1)}$ become isomorphic, even as Virasoro-Kac-Moody modules.

A.2. The Virasoro Algebra and Its Unitary Representations

Let $g^{(\tau)}$ denote an affine Kac-Moody algebra, d a homogeneous gradation, g_0 the horizontal subalgebra. If we only consider the finite algebra g , the Casimir operator:

$$\text{Cas}_g = \sum_{a,b} K_{ab} e^a e^b \tag{A2-1}$$

commutes with g . In (A2-1), the summation is taken over all the generators of g , and K_{ab} is the standard Killing metric scaled to:

$$\text{Cas}_g(A) = (A, A + 2\varrho), \tag{A2-2}$$

where A is a highest weight and ϱ the Weyl vector. In the adjoint representation, with highest weight ϕ , we have $\text{Cas}(\phi) = 2h^\vee$, where h^\vee is the dual Coxeter number of g . Note that $h^\vee(g^{(\tau)})$ does not depend on τ .

In the case of the affine algebra $g^{(\tau)}$, there is an infinite number of generators and the summation must be regularized. In the homogeneous gradation (A1-15), we define a normal ordered product of generators as:

$$\circ e^a_m e^b_n \circ = \begin{cases} e^a_m e^b_n, & m < n, \\ \frac{1}{2}(e^a_m e^b_n + e^b_n e^a_m), & m = n, \\ e^b_n e^a_m, & m > n. \end{cases} \tag{A2-3}$$

Let $\tau = 1, 2$ or 3 denote the twist. We define the Virasoro generators as:

$$L_m = \frac{1}{2(k+h^\vee)} \sum_{a,b} \sum_{n \in \frac{\mathbb{Z}}{\tau}} K_{ab} \circ e^a_{m+n} e^b_{-n} \circ + v \delta_{m,0}, \tag{A2-4}$$

where v , the energy of the twisted vacuum, is equal to:

$$v = \frac{\tau - 1}{4\tau^2} \cdot \frac{k(\dim g - \dim g_0)}{k + h^\vee}. \tag{A2-5}$$

The L_n satisfy the Virasoro [7] algebra which is the central extension of the algebra of vector fields on the circle:

$$[L_m, L_n] = (m - n)L_{m+n} + \frac{c}{12}(m^3 - m)\delta_{m+n,0}, \tag{A2-6a}$$

$$[L_m, e^a_n] = -n e^a_{m+n}. \tag{A2-6b}$$

L_0 can be identified with the derivation d (A 1-13)–(A 1-16). The new central charge, c , is related to k , the dimension d of g and the dual Coxeter number h^\vee of g by the so-called Sugawara equation:

$$c = \frac{kd}{k + h^\vee}. \tag{A2-7}$$

The Virasoro generators can be defined in a similar way for the gradation corresponding to an arbitrary automorphism of order M of g (A 1-25). The central charge is not modified. It is an intrinsic characterization of the algebra. However, the energy v of the vacuum becomes [2]:

$$v = \frac{c}{4M^2} \sum_{j=0}^M j(M-j) \frac{\dim g_j}{\dim g}.$$

In a highest weight representation of $g^{(t)}$, the L_0 eigenvalue of the highest weight is given by:

$$\Delta = \frac{\text{Cas}_{g_0}(\Delta)}{2(k + h^\vee)j(g/g_0)} + v, \tag{A2-8}$$

where $j(g/g_0)$ is the Dynkin's index of the imbedding of g_0 in g . Hereby, we fix the coefficients Δ_i , left undetermined in the definition of the fundamental weights (A 1-32). Note that the normal order (A2-3) and hence the conformal weight Δ are gradation dependent.

The linear coefficient $(-mc/12)$ in (A2-6a) is not intrinsic. Let us define the "improved energy tensor" corresponding in the dual string models [22] to the subtraction of the intercept:

$$\tilde{L}_n = L_n - \frac{c}{24} \delta_{n,0}. \tag{A2-9}$$

The \tilde{L}_n satisfy the modified relations:

$$[\tilde{L}_m, \tilde{L}_n] = (m - n)\tilde{L}_{m+n} + \frac{c}{12} m^3 \delta_{m+n,0} \tag{A2-10}$$

in which the linear term $(-nc/12)$ has totally disappeared. The passage from L to \tilde{L} improves the modular properties of the characters of the representations of the Virasoro algebra and facilitates the evaluation of the asymptotics of the string functions [2].

Since the Virasoro algebra commutes with the horizontal algebra, the so-called string of weights:

$$S_\mu = \{\mu - n\delta, n \in \mathbb{N}, \mu \in V_A, \mu + \delta \notin V_A\} \tag{A2-11}$$

carries a representation of the Virasoro algebra L . By construction, μ is a highest weight of the Virasoro algebra. Furthermore, this representation is unitarizable whenever the representation of the Kac-Moody algebra is. The character of L_0 in the string, noted

$$C_A^\mu(q) = \text{Tr}_{S_\mu}(q^{\tilde{L}_0 - \tilde{R}^2/2k}), \tag{A2-12}$$

where $\bar{\mu}$ is the horizontal component of μ , is called the string function of the weight μ in the \mathcal{A} representation. Strings which are conjugated under the Weyl group of the affine algebra have identical string functions. Thus, there is only a finite number of string functions in a given representation. In particular, the level-one representations of the simply laced and twisted algebras, all of type A, D, E , have a unique string function. Since μ are eigenvectors of the horizontal Cartan subalgebra, the character of $V(\mathcal{A})$ follows from the knowledge of all string functions.

The exact form of the string functions is difficult to establish in the general case. Kac and Peterson [2] found a number of them using their covariance under the modular group. In this paper, we shall recover a number of their results and a few new ones by explicit constructions of the representations and by the analysis of non-regular subalgebras of Kac-Moody algebras (see Sect. D).

Consider a highest weight vector $|\Delta\rangle$:

$$\begin{aligned} L_0|\Delta\rangle &= \Delta|\Delta\rangle, \\ L_n|\Delta\rangle &= 0, \quad n > 0. \end{aligned} \tag{A2-13}$$

Define the Verma module as the completion of the linear span of vectors of the type

$$\prod_k (L_{-k})^{n_k} |\Delta\rangle. \tag{A2-14}$$

We wish to find a unitarizable representation, carrying a sesquilinear form such that

$$L_m^+ = L_{-m}. \tag{A2-15}$$

In particular Δ and c must be real positive since

$$\langle \Delta | L_n L_{-n} | \Delta \rangle = \left(2n\Delta + \frac{c}{24}(n^3 - n) \right) \langle \Delta | \Delta \rangle \geq 0. \tag{A2-16}$$

The Verma module is irreducible if it contains no invariant submodule. Kac [12] has shown that this happens if Δ is real positive and $c > 1$. Then the “improved” character of the Virasoro algebra is simply given by:

$$ch(\Delta, c)(q) = q^{\Delta - \frac{c}{24}} \varphi(q)^{-1}, \tag{A2-17}$$

where $\varphi(q)$ denotes the infinite product:

$$\varphi(q) = \prod_{n>0} (1 - q^n). \tag{A2-18}$$

When $c = 1$, the Verma module is reducible if $\Delta = n^2/4$, n integer, and contains a maximal submodule with $\Delta = (n+2)^2/4$ [12]. In this case the character is:

$$ch\left(\frac{n^2}{4}, 1\right) = \left(q^{\frac{n^2}{4}} - q^{\frac{(n+2)^2}{4}} \right) \eta(q)^{-1}, \tag{A2-19}$$

where $\eta(q) = q^{1/24} \cdot \varphi(q)$ is the Dedekind function. When $c = 0$, the only unitary representation is the trivial one. On the other hand, if $0 < c < 1$ the Verma module

contains points of negative norm. However, it follows from Kac's determinant formula [12] that for

$$c = 1 - \frac{6(p-q)^2}{pq},$$

$$\Delta = \Delta_{rs} = \frac{(rp - sq)^2 - (p-q)^2}{4pq},$$
(A2-20)

with p, q coprimes, the Verma module is reducible. Belavin et al. [29] noticed that these modules are relevant in statistical mechanics. This led Friedan, Qiu, and Shenker to the important discovery that, when $c < 1$, the only possibly unitary highest weight representations of the Virasoro algebra have c and Δ as in (A2-20), with $p - q = 1$. This theorem was announced in [30], the details can be found in [31]. In particular, we shall use the fact that, in these series, there is only a finite number of unitary weights given by (see Table 6):

$$c_m = 1 - \frac{6}{m(m+1)},$$

$$\Delta_{rs} = \frac{(r(m+1) - sm)^2 - 1}{4m(m+1)}, \quad 0 \leq r \leq s \leq m.$$
(A2-21)

Table 6. Lowest unitary conformal weights Δ_{rs} of the Virasoro algebra when the central charge c is less than 1 (A2-21)

$c = 1 - 6/m(m+1), \quad \Delta_{rs} = ((r(m+1) - sm)^2 - 1)/4m(m+1).$

$m=3, \quad c=1/2,$	<table style="border-collapse: collapse; margin: auto;"> <tr> <td style="border-right: 1px solid black; padding: 5px;">r</td> <td style="padding: 5px;">1</td> <td style="padding: 5px;">2</td> </tr> <tr> <td style="border-right: 1px solid black; border-bottom: 1px solid black; padding: 5px;">s</td> <td style="border-bottom: 1px solid black; padding: 5px;"></td> <td style="border-bottom: 1px solid black; padding: 5px;"></td> </tr> <tr> <td style="border-right: 1px solid black; padding: 5px;">1</td> <td style="padding: 5px;">0</td> <td style="padding: 5px;">1/2</td> </tr> <tr> <td style="border-right: 1px solid black; padding: 5px;">2</td> <td style="padding: 5px;"></td> <td style="padding: 5px;">1/16</td> </tr> </table>	r	1	2	s			1	0	1/2	2		1/16																		
r	1	2																													
s																															
1	0	1/2																													
2		1/16																													
$m=4, \quad c=7/10,$	<table style="border-collapse: collapse; margin: auto;"> <tr> <td style="border-right: 1px solid black; padding: 5px;">r</td> <td style="padding: 5px;">1</td> <td style="padding: 5px;">2</td> <td style="padding: 5px;">3</td> </tr> <tr> <td style="border-right: 1px solid black; border-bottom: 1px solid black; padding: 5px;">s</td> <td style="border-bottom: 1px solid black; padding: 5px;"></td> <td style="border-bottom: 1px solid black; padding: 5px;"></td> <td style="border-bottom: 1px solid black; padding: 5px;"></td> </tr> <tr> <td style="border-right: 1px solid black; padding: 5px;">1</td> <td style="padding: 5px;">0</td> <td style="padding: 5px;">7/16</td> <td style="padding: 5px;">3/2</td> </tr> <tr> <td style="border-right: 1px solid black; padding: 5px;">2</td> <td style="padding: 5px;"></td> <td style="padding: 5px;">3/80</td> <td style="padding: 5px;">3/5</td> </tr> <tr> <td style="border-right: 1px solid black; padding: 5px;">3</td> <td style="padding: 5px;"></td> <td style="padding: 5px;"></td> <td style="padding: 5px;">1/10</td> </tr> </table>	r	1	2	3	s				1	0	7/16	3/2	2		3/80	3/5	3			1/10										
r	1	2	3																												
s																															
1	0	7/16	3/2																												
2		3/80	3/5																												
3			1/10																												
$m=5, \quad c=4/5,$	<table style="border-collapse: collapse; margin: auto;"> <tr> <td style="border-right: 1px solid black; padding: 5px;">r</td> <td style="padding: 5px;">1</td> <td style="padding: 5px;">2</td> <td style="padding: 5px;">3</td> <td style="padding: 5px;">4</td> </tr> <tr> <td style="border-right: 1px solid black; border-bottom: 1px solid black; padding: 5px;">s</td> <td style="border-bottom: 1px solid black; padding: 5px;"></td> <td style="border-bottom: 1px solid black; padding: 5px;"></td> <td style="border-bottom: 1px solid black; padding: 5px;"></td> <td style="border-bottom: 1px solid black; padding: 5px;"></td> </tr> <tr> <td style="border-right: 1px solid black; padding: 5px;">1</td> <td style="padding: 5px;">0</td> <td style="padding: 5px;">2/5</td> <td style="padding: 5px;">7/5</td> <td style="padding: 5px;">3</td> </tr> <tr> <td style="border-right: 1px solid black; padding: 5px;">2</td> <td style="padding: 5px;"></td> <td style="padding: 5px;">1/40</td> <td style="padding: 5px;">21/40</td> <td style="padding: 5px;">13/8</td> </tr> <tr> <td style="border-right: 1px solid black; padding: 5px;">3</td> <td style="padding: 5px;"></td> <td style="padding: 5px;"></td> <td style="padding: 5px;">1/15</td> <td style="padding: 5px;">2/3</td> </tr> <tr> <td style="border-right: 1px solid black; padding: 5px;">4</td> <td style="padding: 5px;"></td> <td style="padding: 5px;"></td> <td style="padding: 5px;"></td> <td style="padding: 5px;">1/8</td> </tr> </table>	r	1	2	3	4	s					1	0	2/5	7/5	3	2		1/40	21/40	13/8	3			1/15	2/3	4				1/8
r	1	2	3	4																											
s																															
1	0	2/5	7/5	3																											
2		1/40	21/40	13/8																											
3			1/15	2/3																											
4				1/8																											

The characters of these representations can be found in Feigen and Fuchs [32] or in Rocha-Caridi [33]:

$$\begin{aligned}
 ch(c_m, \Delta_{rs}) &= \left(\prod_{n>0} (1 - q^n) \right)^{-1} \left(\sum_{n \in \mathbb{Z}} (-q^{an} + q^{bn}) \right), \\
 a_n &= \frac{(2m(m+1)n + (m+1)r + ms)^2 - 1}{4m(m+1)}, \\
 b_n &= \frac{(2m(m+1)n + (m+1)r - ms)^2 - 1}{4m(m+1)}.
 \end{aligned}
 \tag{A2-22}$$

Goddard, Kent, and Olive [34] and also Kac and Wakimoto [35] have completed the theorem of Friedan, Qiu, and Shenker and shown that all the representation of type (A2-10) with $p - q = 1$ are indeed unitary since they occur in the splitting of the product of the basic and the level $p - 2$ representation of $A_1^{(1)}$ with respect to the diagonal $A_1^{(1)}$. The demonstration is based upon a very elegant and simple observation of Goddard, Kent, and Olive [23]. Let h be a sub-algebra of the horizontal algebra g_0 and let us choose a basis of g_0 such that the first $(\dim h)$ generators form a basis of the h algebra. Denote by $L_n(h)$ the Virasoro generators of the affinization of h , and by $c(h)$ their central charge. Then, Eq. (A2-6) applied to g and h implies that:

$$[L_n(g) - L_n(h), h] = 0, \tag{A2-22}$$

and hence:

$$[L_n(g) - L_n(h), L_n(h)] = 0. \tag{A2-23}$$

As the $L(g)$ and $L(h)$ satisfy the Virasoro algebra, their difference does:

$$K_n(g/h) = L_n(g) - L_n(h). \tag{A2-24}$$

The central charge of the K algebra is the difference of the two central charges,

$$c(g/h) = c(g) - c(h). \tag{A2-25}$$

In the case of $g^{(1)} = A_1^{(1)}[k = m - 2] * A_1^{(1)}[k = 1]$ and $h^{(1)} = A_1^{(1)}[k = m - 1]$ -diagonal, using (A2-7) we find indeed:

$$c(g/h) = 3 \frac{m-2}{m} + 1 - 3 \frac{m-1}{m+1} = 1 - \frac{6}{m(m+1)}.$$

By computing the characters, one may verify that all the weights $\Delta_{r,s}$ occur in the decomposition [34, 35]. We shall use this construction repeatedly throughout our paper.

A.3. Application: The $A_1^{(1)}$ Algebra

As an illustration, we wish to give here a detailed description of the simplest Kac-Moody algebra, $A_1^{(1)}$, the affinisation of $su(2)$. The vertex operator constructions of its representations become more and more involved as the level k increases. They will be given in part B for $k = 1$ and 2 and in part C for arbitrary k .

The Cartan matrix of $A_1^{(1)}$ is:

$$A_{ij} = \begin{bmatrix} 2 & -2 \\ -2 & 2 \end{bmatrix}. \tag{A3-1}$$

The root system, in the homogeneous gradation is:

$$\Delta = \{\varepsilon\alpha + n\delta; \varepsilon = 0, +1, -1; n \in \mathbb{Z}\}, \tag{A3-2}$$

where α denotes the positive simple root of $su(2)$, $(\alpha, \alpha) = 2$, and δ the null vector of H^* , dual to the central charge, $\delta(k) = 1$. The adjoint representation neither has a highest weight, nor a lowest weight. The real roots, $\alpha + n\delta$, have positive norm $+2$, while the imaginary roots, $n\delta$, have zero norm. In $A_1^{(1)}$, all the roots are non-degenerate.

If we denote by e_n^\pm and by h_n the generators corresponding to the root $(\pm\alpha + n\delta)$ and $n\delta$, respectively, the non-trivial commutation relations of the algebra (A1-22) read:

$$\begin{aligned} [h_m, h_n] &= 2mk\delta_{m+n, 0}, \\ [h_m, e_n^\pm] &= \pm 2e_{m+n}^\pm, \\ [e_m^+, e_n^-] &= h_{m+n} + mk\delta_{m+n, 0}. \end{aligned} \tag{A3-3}$$

Note that any pair of real roots, say $\pm(\alpha + p\delta)$, generates a subalgebra A_1 of $A_1^{(1)}$:

$$[e_p^+, e_{-p}^-] = h_0 + pk. \tag{A3-4}$$

A system of simple roots defining a homogeneous gradation is:

$$\alpha_{(0)} = -\alpha + \delta, \quad \alpha_{(1)} = \alpha. \tag{A3-5}$$

The corresponding Cartan operators are:

$$h_{(0)} = -h_0 + k, \quad h_{(1)} = h_0. \tag{A3-6}$$

Since each Cartan operator corresponds to a finite $SU(2)$ subalgebra, a highest weight representation can be unitary only if $h_{(0)}$ and $h_{(1)}$ have non-negative integer eigenvalues, δ_0 and δ_1 . Therefore, $k = \delta_0 + \delta_1$, is a positive integer.

The Weyl group is, as usual, the group generated by the simple reflections:

$$\begin{aligned} R_\alpha: H^* &\rightarrow H^*, \\ x &\rightarrow R_\alpha(x) = x - 2(x, \alpha)/(\alpha, \alpha)\alpha. \end{aligned} \tag{A3-7}$$

Since the Cartan matrix is degenerate, the Weyl group is infinite with an Abelian component. It can be parametrized by:

a) the reflexions in α

$$R_\alpha(\varepsilon\alpha + n\delta) = -\varepsilon\alpha + n\delta, \tag{A3-8}$$

b) the translations parallel to δ

$$\begin{aligned} T_m &= R_{-\alpha + m\delta} \circ R_\alpha, \\ T_m(\varepsilon\alpha + n\delta) &= \varepsilon\alpha + (-2m\varepsilon + n)\delta, \end{aligned} \tag{A3-9}$$

with $\varepsilon = +1, -1, 0$.

Note that the imaginary roots are Weyl invariant. The translation $T_{1/2}$ is not an element of the Weyl group, but corresponds to the outer automorphism of $A_1^{(1)}$ which exchanges the simple roots $\alpha_{(0)}$ and $\alpha_{(1)}$ and thus, the spinor and the tensor representations (see below and Fig. 1).

Consider a representation $V(\Lambda)$ of level k with highest weight $|h, k\rangle = |\Lambda\rangle$:

$$\begin{aligned} h_{(0)}|\Lambda\rangle &= \delta_{(0)}|\Lambda\rangle = (k-h)|\Lambda\rangle, \\ h_{(1)}|\Lambda\rangle &= \delta_{(1)}|\Lambda\rangle = h|\Lambda\rangle, \\ e^-_{-n+1}|\Lambda\rangle &= e^+_n|\Lambda\rangle = 0, \quad n \geq 0. \end{aligned} \tag{A 3-10}$$

Let A_0 denote the fundamental weight, $\alpha_{(0)}(A_0) = \delta_{i0}$. The A_0 component of the weights of $V(\Lambda)$ is k . The α -component of the weights are integral in the tensor representations, and half integral in the spinor representations.

The action of the Weyl group on $V(\Lambda)$ looks very different from its action on the root diagram. If $\mu = (p\alpha - q\delta + kA_0)$ is a weight of $V(\Lambda)$, we have:

$$\begin{aligned} R_\alpha(\mu) &= -p\alpha - q\delta + kA_0, \\ T_m(\mu) &= kA_0 + (p + mk)\alpha - \left(q + \frac{(p + mk)^2 - p^2}{k} \right) \delta. \end{aligned} \tag{A 3-11}$$

If we project onto the weight lattice of A_1 , the Weyl group acts, when $k=1$, as the affine Weyl group of A_1 , i.e. as the group of automorphisms of the root lattice of A_1 , including the translation in α . On the other hand, as the Weyl group preserves the norm

$$(\mu, \mu) = (\alpha, \alpha)p^2 - 2kq, \tag{A 3-12}$$

all the weights of the representation $V(\Lambda)$ are inside the parabola:

$$P_\Lambda = \{ \mu, (\mu, \mu) = (\Lambda, \Lambda) \}. \tag{A 3-13}$$

The weights closest to the parabola are highest weights of the Virasoro algebra. In the case $|h=0, k>1\rangle$, $k(\alpha - \delta)$ is a highest weight of the Virasoro algebra. Since the Virasoro algebra commutes with the horizontal algebra A_1 , $(-k\delta)$ is also. However, the Verma modules ($c > 1, \Delta = 0$) and ($c > 1, \Delta = k$) are irreducible. Hence, the partition function of the string of weights of $A_1^{(1)}[k \geq 2]$ is larger than $1/\eta(q)$. In other words, the representation space is necessarily bigger than the Fock space of a single boson.

The outer automorphism $T_{1/2}$ maps the highest weight $|h=0, k=1\rangle$ of the basic representation, which consists solely of tensors of $so(3)$, onto the highest weight $|h=1, k=1\rangle$ of the spin representation, which consists solely of spinors of $so(3)$. As such, $T_{1/2}$ acts as a supersymmetry, but it does not commute with the energy operator L_0 (see Fig. 1).

It is easy to compute the multiplicity of a weight μ in the highest weight module $V(\Lambda)$ using the recursion equation of Racah:

$$0 = \sum_{w \in \text{Weyl}} \varepsilon(w) \text{mult}_\Lambda(\mu + \varrho - w(\varrho)) \tag{A 3-15}$$

for $(\mu + \varrho)$ not Weyl-conjugated to $(\Lambda + \varrho)$, and the initial condition

$$\text{mult}_\Lambda(\Lambda) = 1, \quad \text{mult}_\Lambda(\Lambda + \varrho - w(\varrho)) = 0.$$

This equation specializes in the case of $A_1^{(1)}$ to

$$\text{mult}_A(\mu) = \sum_{n \in \mathbb{Z}} (-1)^n \text{mult}_A \left(\mu + n\alpha + \frac{n(n-1)}{2} \delta \right). \tag{A3-16}$$

Using this formula, Feingold and Lepowski [36] proved that the string function (A2-12) of the basic module of $A_1^{(1)}$ is

$$C_A^A(q) = \eta(q)^{-1}. \tag{A3-17}$$

For future use, we establish in Fig. 3 that

$$\begin{aligned} \text{mult}_{3A_0}(3A_0 - 3\delta) &= 6, \\ \text{mult}_{A_0 + 2A_1}(3A_0 - \delta) &= 3. \end{aligned} \tag{A3-18}$$

A.4. Two Dimensional Conformally Invariant Q.F.T. and Algebras

We shall consider in this section the Kac-Moody and Virasoro algebras from the alternative point of view of two dimensional quantum field theory. We shall describe how the algebraic properties of a set of currents come from their operator product expansions (O.P.E.) [6, 29, 37].

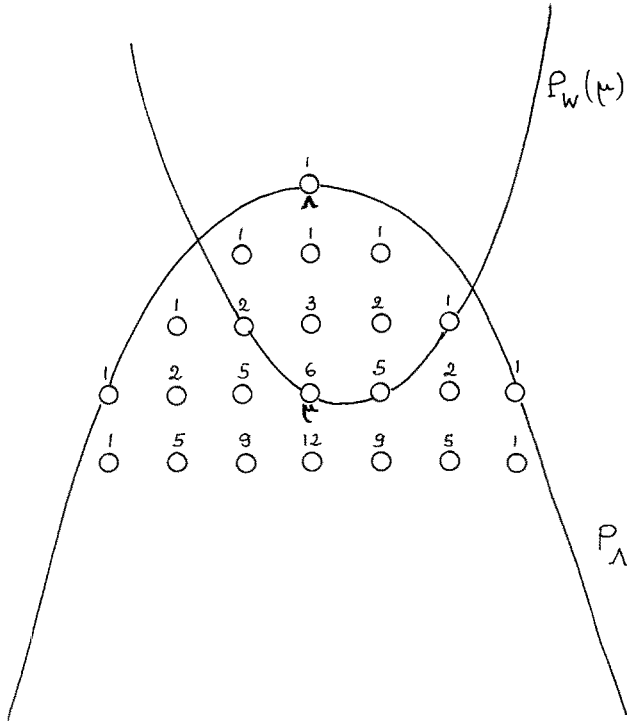

Fig. 3. The Racah construction (A3-18). The weight diagram of the representation $\begin{matrix} 3 \\ \circ \end{matrix}$ of $A_1^{(1)}$ is shown. Its envelope is the parabola P_A supporting the Weyl orbit of λ . $P_w(\mu)$ is the parabola $(\mu - \rho + w(\rho))$ used in the Racah recursion. The alternated sum of the multiplicities of the weights supported by this parabola is zero for every choice of μ

Consider a two dimensional field $\phi(\tau, \sigma)$. If it depends on σ and τ only through the complex coordinate $z, z = \exp(-\tau + i\sigma)$, it is called a chiral field.

Let $J^a(z)$ denote a set of chiral fields satisfying the operator product expansion:

$$J^a(z)J^b(w) = \frac{k\delta^{ab}}{(z-w)^2} + \frac{f^{ab}_c}{z-w} J^c(w) + \text{regular} \tag{A4-1}$$

defined for $|z| > |w|$ and, by analytic continuation, for all values of (z, w) except $z = 0, w = 0, z = w$. We assume that this expansion is even under permutation of $J^a(z)$ and $J^b(w)$:

$$J^a(z)J^b(w) = J^b(w)J^a(z). \tag{A4-2}$$

Then, define the Laurent coefficients of the J^i fields:

$$J^a_n = \oint_{C_0} \frac{dz}{2\pi i} z^n J^a(z), \quad J^a(z) = \sum_z J^a_n z^{-n-1}. \tag{A4-3}$$

The contour C_0 turns counter-clockwise around the origin of the z -complex plane. The commutation relations of the J^a_n operators follow from the O.P.E. (A4-1):

$$[J^a_m, J^b_n] = \left(\frac{1}{2\pi i}\right)^2 \left\{ \oint dz \oint dw - \oint dz \oint dw \right\} J^a(z)J^b(w)z^m w^n. \tag{A4-4}$$

$|z| > |w| \quad |z| < |w|$

At fixed w , the z -contour can be deformed in the region where the OPE is analytic and we just pick up, at fixed w , the poles located in between the 2 z -contours. In this method, it is essential that the OPE should have no cut and be of defined parity (A4-2) in order to be able to identify the two integrands occurring in the commutator. Let us illustrate it in the case of the $J^a(z)$ fields. The commutation relations become:

$$\begin{aligned} [J^a_m, J^b_n] &= \oint_{C_0} \frac{dw}{2\pi i} \oint \frac{dz}{2\pi i} z^m w^n J^a(z)J^b(w) \\ &= f^{ab}_c J^c_{m+n} + mk\delta^{ab}\delta_{m+n,0}. \end{aligned} \tag{A4-5}$$

The Kac-Moody commutation relations (A1-20) are equivalently reexpressed in the field theory language by the O.P.E. (A4-1). The hermitic conjugation relation,

$$(J^a_n)^+ = J^a_{-n} \tag{A4-6a}$$

is equivalent to the hermiticity property of the J^a field,

$$z \cdot J^a(z) = 1/z^* \cdot J^a(1/z^*). \tag{A4-6b}$$

The same techniques can also be applied to the Virasoro algebra. Let $T(z)$ be a stress tensor satisfying the O.P.E.:

$$T(z)T(w) = \frac{c/2}{(z-w)^4} + \frac{2}{(z-w)^2} T(w) + \frac{1}{z-w} \partial_w T(w) + \text{reg}_0. \tag{A4-7}$$

The Laurent coefficients of the stress tensor $T(z)$

$$T(z) = \sum_{n \in \mathbb{Z}} L_n z^{-n-2} \tag{A4-8}$$

satisfy the Virasoro algebra (A2-6) with central charge c .

Furthermore, the primary fields, $\phi_\Delta(z)$, of the Virasoro algebra (those which have a defined conformal weight), are defined by their commutation relations with the Virasoro generators:

$$[L_n, \phi_\Delta(z)] = z^n(z\partial_z + (n+1)\Delta)\phi_\Delta(z). \tag{A4-9}$$

Δ is the conformal weight. These commutation relations follow from the O.P.E.:

$$T(z)\phi_\Delta(w) = \frac{\Delta}{(z-w)^2}\phi_\Delta(w) + \frac{1}{z-w}\partial_w\phi_\Delta(w) + \text{reg.} \tag{A4-10}$$

In particular, the commutation relations (A2-6) between the Virasoro and the Kac-Moody generators mean that the currents $J^a(z)$ are primary fields for the Virasoro algebra defined in Eq. (A2-4), with conformal weight one.

Let us now consider the example of free bosonic or fermionic fields. Let A^* be a one dimensional lattice and let us denote by $|p\rangle$ its elements. Define on A^* the action of the Abelian translation group:

$$e^{iaq}|p\rangle = |p+\alpha\rangle. \tag{A4-11a}$$

Let x_n denote the modes of a harmonic oscillator

$$[x_m, x_n] = m\delta_{m+n, 0}. \tag{A4-12a}$$

We identify x_0 with the operator p , conjugated to q :

$$[p, q] = i, \tag{A4-11b}$$

$$x_0|p\rangle = p|p\rangle. \tag{A4-12b}$$

If we consider the conjugation $x_n^+ = x_{-n}$, and the normalization $\langle p|p\rangle = 1$, the sesquilinear form defined on the union of the Fock spaces constructed on the vacua $|p\rangle$,

$$\mathcal{H} = \bigoplus_{p \in A^*} \left(\prod_k (x_{-k})^{n_k} \right) |p\rangle \tag{A4-13}$$

is positive defined.

Over \mathcal{H} , we define a free Fubini-Veneziano field [6]:

$$X(z) = q - ip \text{Log} z - i \sum_{n \neq 0} x_{-n} \frac{z^n}{n}, \tag{A4-14a}$$

and its associated momentum operator:

$$P(z) = iz\partial_z X(z) = \sum_{n \in \mathbb{Z}} x_{-n} z^n. \tag{A4-14b}$$

Defining the normal order by:

$$\circ x_m x_n \circ = \begin{cases} x_m x_n, & m \leq n, \\ x_n x_m, & m \geq n \end{cases} \tag{A4-15a}$$

and

$$\circ pq \circ = \circ qp \circ = qp, \tag{A4-15b}$$

we obtain the O.P.E. of the $P(z)$ field

$$P(z)P(w) = \frac{zw}{(z-w)^2} + \text{:}P(z)P(w)\text{:} . \tag{A4-16}$$

Reciprocally, one could postulate the definitions (A4-14b) and (A4-16) and deduce (A4-12a).

To the X field, we can associate a free stress tensor which generates a free Virasoro algebra:

$$T^X(z) = \frac{1}{2} \text{:}\partial_z X(z)\partial_z X(z)\text{:} . \tag{A4-17}$$

The O.P.E. of $T(z)$ follows from Eq. (A4-16) and the Wick theorem. The central charge of this free Virasoro algebra is one.

On the other hand, let us consider two types of two-dimensional Majorana-Weyl fermion field Γ :

$$\Gamma(z) = \sum b_{-n} z^n , \tag{A4-18}$$

where the summation is over $n \in Z + 1/2$ in the Neveu-Schwarz case (N-S), and over $n \in Z$ in the Ramond case (R) [8]. Their Laurent coefficients satisfy the canonical anti-commutation relations

$$\{b_m, b_n\} = \delta_{m+n, 0} . \tag{A4-19}$$

Once more, the anti-commutation relations are equivalently expressed by the O.P.E. of the $\Gamma(z)$ fields,

$$\Gamma(z)\Gamma(w) = \Delta(z, w) + \text{:}\Gamma(z)\Gamma(w)\text{:} , \tag{A4-20}$$

where

$$\Delta(z, w) = \begin{cases} \frac{z+w}{2(z-w)} & \text{R.} \\ \frac{\sqrt{zw}}{z-w} & \text{N.S.} \end{cases} \tag{A4-21}$$

and where $\text{:}\text{:}$ denotes the fermionic normal ordering. In the Ramond case, the normal ordering of the zero modes is specified by:

$$\text{:}\Gamma(z)\Gamma(z)\text{:} = 0 .$$

Anti-commutation relations, instead of commutation relations, come from the odd parity of the two point functions $\Delta(z, w)$. The free stress tensor of the Γ field, which generates a Virasoro algebra, is:

$$z^2 T^\Gamma(z) = \frac{1}{2} \text{:}z\partial_z(\Gamma(z))\Gamma(z)\text{:} \pm \begin{cases} \frac{1}{16} & \text{R.} \\ 0 & \text{N.S.} \end{cases} \tag{A4-22}$$

Its Virasoro central charge is one half.

In the following sections, we shall construct representations of Kac-Moody algebras from these fields. These constructions extensively use the properties of the string vertex operators. Let $X^i(z)$, $i = 1$ to ℓ , be ℓ free bosonic fields. Then, define the

vertex operator $U(\alpha, z)$ as:

$$U(\alpha, z) = \circ \exp i\alpha \cdot X(z) \circ \\ = \exp \left[\sum_{n>0} \alpha \cdot x_{-n} \frac{z^n}{n} \right] e^{i\alpha \cdot q} z^{\alpha \cdot p} \exp \left[- \sum_{n>0} \alpha \cdot x_n \frac{z^{-n}}{n} \right], \quad (\text{A4-23})$$

where $\alpha = (\alpha^i, i = 1 \text{ to } \ell)$ is a ℓ dimensional vector, and we have used the normal ordering (A4-15b). A different ordering of the zero modes p and q , as used for example by Frenkel, implies several modifications of the next formulae.

Note that $U(\alpha, z)$ acts by translation on the zero modes, p^i . The $U(\alpha, z)$ fields satisfies the hermiticity properties

$$(z^{\alpha/2} U(\alpha, z))^+ = \bar{z}^{-\alpha/2} U \left(-\alpha, \frac{1}{\bar{z}} \right), \quad (\text{A4-24})$$

and also the famous O.P.E.

$$P^a(z)U(\alpha, w) = \frac{z}{z-w} \alpha^a U(\alpha, w) + \dots, \quad (\text{A4-25})$$

$$U(\alpha, z)U(\beta, w) = (z-w)^{\alpha \cdot \beta} \circ \exp i(\alpha \cdot X(z) + \beta \cdot X(w)) \circ.$$

This expression converges for $|z| > |w|$, and it can be analytically continued for $|z| < |w|$ except poles at $z=0$, $w=0$, and $z=w$. Note that its pole structure and symmetry under the exchange of α and β and z and w is controlled by the scalar product $\alpha \cdot \beta$. Equation (A4-25) has a well defined symmetry and no cut if and only if $\alpha \cdot \beta$ is integral.

The vertex operators $U(\alpha, z)$ are primary fields, of the free Virasoro algebra (A4-17), with conformal weight $\alpha \cdot \alpha/2$.

$$T(z)U(\alpha, w) = \frac{\alpha^2}{2(z-w)^2} + \frac{1}{z-w} \circ \partial_w U(\alpha, w) \circ. \quad (\text{A4-26})$$

The importance of this O.P.E. can be illustrated by the fermion-boson equivalence in two dimensional quantum field theory [9, 10, 17, 28]. Suppose that $\alpha \cdot \alpha = 1$, then from (A4-25):

$$\{B_m^\alpha, B_n^\alpha\} = 0, \quad \{B_m^\alpha, B_n^{-\alpha}\} = \delta_{m+n, 0}. \quad (\text{A4-27})$$

The modes B_n^α of the field $B(\alpha, z) = z^{1/2} U(\alpha, z)$ form a Clifford algebra.

The hermitic fermionic fields are defined, from the bosonic field, by:

$$\Gamma_+^\alpha(z) = \frac{1}{\sqrt{2}} (B(\alpha, z) + B(-\alpha, z)), \\ \Gamma_-^\alpha(z) = \frac{i}{\sqrt{2}} (B(\alpha, z) - B(-\alpha, z)). \quad (\text{A4-28})$$

If the momentum p belongs to the lattice $Z\alpha$, Γ_\pm^α is of Neveu-Schwarz type, whereas if p belongs to the shifted lattice $(Z + 1/2)\alpha$, Γ_\pm^α is a Ramond field. Reciprocally, from the fermionic fields Γ_\pm^α , one can define the bosonic field by

$$\alpha \cdot P(z) = \circ B(\alpha, z) B(-\alpha, z) \circ, \quad (\text{A4-29})$$

where the normal ordering \circledast is defined by Eq. (A4-21), namely,

$$B(\alpha, z)B(-\alpha, w) = \circledast B(\alpha, z)B(-\alpha, w) \circledast + A(z, w). \tag{A4-30}$$

In Sect. C, we describe how the bosonic and fermionic Virasoro algebras are related [relation (C1-1) particularized to the $su(2)$ algebra]. By evaluating the Virasoro character via the bosonic or fermionic description, one shows that this boson-fermion equivalence is related to the Jacobi identity:

$$\begin{aligned} \left(\sum_{n \in \mathbb{Z}} q^{n^2/2} \right) \prod_n (1 - q^n)^{-1} &= \prod_n (1 + q^{n+\frac{1}{2}})^2, \\ \left(\sum_{n \in \mathbb{Z} + \frac{1}{2}} q^{n^2/2} \right) \prod_n (1 - q^n)^{-1} &= 2\sqrt{q} \prod_n (1 + q^n)^2. \end{aligned}$$

It is also possible to formulate another boson-fermion equivalence which mixes the N-S. and R. fields. This fermionization, built upon a bosonic field of defined parity, will be the key of the constructions of the twisted affine algebras, Sect. B.5.

Consider a bosonic field $Y_{(-)}(z)$, containing only odd modes,

$$Y_{(-)}(z) = -i\sqrt{2} \sum_{n \in 2\mathbb{Z}+1} x_{-n} \frac{z^n}{n}, \tag{A4-31}$$

where the x_{2n+1} obey the usual commutation relations (A4-12). Its two point function is:

$$\langle Y_{(-)}(z)Y_{(-)}(w) \rangle = -\text{Log} \left(\frac{z-w}{z+w} \right). \tag{A4-32}$$

Now, define the vertex operators $U_{(-)}(r, z)$,

$$U_{(-)}(r, z) = \frac{1}{2} \circledast \exp ir \cdot Y_{(-)}(z) \circledast. \tag{A4-33}$$

Their O.P.E. read:

$$U_{(-)}(r, z)U_{(-)}(s, w) = \frac{1}{4} \left(\frac{z-w}{z+w} \right)^{r \cdot s} \circledast \exp i(r \cdot Y_{(-)}(z) + s \cdot Y_{(-)}(w)) \circledast, \tag{A4-34}$$

and fully characterize the algebraic properties of the $U_{(-)}(r, z)$ operators. In particular, if the ‘‘root’’ r has length one, the Laurent coefficients, U_n , of the $U_{(-)}(r, z)$ field,

$$U_n = \oint \frac{dz}{2\pi iz} z^n U_{(-)}(r, z)$$

satisfy the Clifford algebra:

$$\{U_m, U_n\} = \frac{(-1)^m}{2} \delta_{m+n, 0}. \tag{A4-35}$$

The hermitic conjugation, $\Gamma_{-n}^+ = (-1)^n \Gamma_n$, follows from the hermiticity property

$$(U_{(-)}(r, z))^+ = U_{(-)} \left(-r, \frac{1}{\bar{z}} \right) = U_{(-)} \left(r, -\frac{1}{\bar{z}} \right). \tag{A4-36}$$

The $U_{(-)}$ field, containing odd and even modes, can be written as the sum of two fermionic fields of defined parity, or in more usual notations, as the sum of a Ramond and a Neveu-Schwarz field:

$$\sqrt{2}U_{(-)}(r, z) = \Gamma_{\mathbf{R}}(z^2) + i\Gamma_{\mathbf{NS}}(z^2) \quad \text{with} \quad \Gamma(z^2)^+ = \Gamma(\bar{z}^{-2}). \quad (\text{A4-37})$$

This fermionization, contrary to the previous one, mixes the R. and N-S. fields. This boson-fermion equivalence is also illustrated by the bosonization relation:

$$P_{(-)}(z) = i\sqrt{2}z\partial_z Y_{(-)}(z) = 2i\sqrt{2}\Gamma_{\mathbf{NS}}(z^2)\Gamma_{\mathbf{R}}(z^2). \quad (\text{A4-38})$$

The fermionic field content of the $U_{(-)}$ operator appears again in its conformal properties. The Virasoro algebra of the $Y_{(-)}$ field

$$L^{(-)}_m = \frac{1}{4} \sum_{n \in 2\mathbb{Z}+1} :x_{-n}x_{2m+n}: + \frac{1}{16}\delta_{m,0} \quad (\text{A4-39})$$

has central charge one. It can also be written, via the boson-fermion equivalence, as the sum of the R. and N-S. stress tensors. This equivalence reflects the Jacobi identity

$$\prod_n (1 - q^{n+\frac{1}{2}})^{-1} = \prod_n (1 + q^n)(1 + q^{n+\frac{1}{2}}). \quad (\text{A4-40})$$

On the other hand, if $X_{(+)}$ (z) is an even field

$$X_{(+)}(z) = q - ip \log z^2 - i\sqrt{2} \sum_{n \in 2\mathbb{Z}} x_{-n} \frac{z^n}{n}, \quad (\text{A4-41})$$

its two point function is:

$$\langle X_{(+)}(z)X_{(+)}(w) \rangle = -\text{Log}(z^2 - w^2). \quad (\text{A4-42})$$

$|z| > |w|$

The vertex operators $U_{(+)}$ (r, z)

$$U_{(+)}(r, z) = \frac{1}{2} : \exp ir \cdot X_{(+)}(z) : = \left(U_+ \left(-r, \frac{1}{z} \right) \right)^+ \quad (\text{A4-43})$$

satisfy the O.P.E.:

$$U_{(+)}(r, z)U_{(+)}(s, w) = \frac{1}{4}(z^2 - w^2)^{r \cdot s} \exp i(r \cdot X_{(+)}(z) + s \cdot X_{(+)}(w)) : . \quad (\text{A4-44})$$

More generally, a bosonic field quantized in modes $x_n, n \in (\tau\mathbb{Z} \pm q)$, has two commuting Virasoro algebras $L^{(q)}$ and $L^{(\tau-q)}$ defined by:

$$L^{(q)}_m = \frac{1}{2\tau} \sum_{n \in \tau\mathbb{Z}+q} :x_{-n}x_{m+n}: + \frac{q(\tau-q)}{4\tau^2} \delta_{n,0}. \quad (\text{A4-45})$$

They have the same central charge, $c=1$, and the same vacuum energy, $v=q(\tau-q)/4\tau^2$.

B. Free Fields Vertex Operator Constructions

B.1. $K=1$ Representations of $A_1^{(1)}$

Let us first consider the algebra $A_1^{(1)}$, in the homogeneous gradation. Following Frenkel, Kac, and Segal [14, 15], we first define a graded Hilbert space, with the correct partition function. Let α denote the simple positive root of A_1 , normed to $\alpha \cdot \alpha = 2$. Consider the weight lattice W of the Lie algebra A_1 . Denote by $|p\rangle$ its elements, and define on W the action of the Abelian translation group by the formula:

$$e^{izq}|p\rangle = |p + \alpha\rangle. \tag{B1-1}$$

On the other hand, consider the affine $U(1)$, or Heisenberg, algebra, corresponding in the physical language to the canonical commutation relations of a free bosonic field

$$[x_m, x_n] = m\delta_{m+n, 0}. \tag{B1-2}$$

We identify x_0 with the variable p , conjugated to q ,

$$[p, q] = i, \quad x_0|p\rangle = p|p\rangle. \tag{B1-3}$$

If we consider the conjugation, $x_n^+ = x_{-n}$, and the normalization $\langle p|p\rangle = 1$, the union of the Fock spaces constructed on the vacua $|p\rangle$ of the weight lattice:

$$\mathcal{H} = \text{Fock}(x) \otimes W \tag{B1-4}$$

is a positive defined Hilbert space.

Over \mathcal{H} , we can construct the level one representations of the Kac-Moody algebra $A_1^{(1)}$ as follows:

i) Consider the Fubini-Veneziano field (A4-14):

$$X(z) = q - ip \text{Log } z - i \sum_{n \neq 0} x_{-n} \frac{z^n}{n}. \tag{B1-5}$$

The fields

$$\sqrt{2}z^{-1}P(z) = i \sqrt{2} \partial_z X(z), \tag{B1-6a}$$

and

$$e^\pm(z) = \text{:exp } i\alpha \cdot X(z)\text{:} \tag{B1-6b}$$

are primary fields of the free Virasoro algebra defined in Eq.(A4-17), with conformal weight one.

ii) Represent the $A_1^{(1)}$ algebra by the Laurent coefficients, h_n and e_n^\pm , of these fields:

$$h_n = \sqrt{2} \oint \frac{dz}{2\pi i} z^{n-1} P(z), \tag{B1-7}$$

$$e_n^\pm = \oint \frac{dz}{2\pi i} z^n e^\pm(z) = (e^\mp_{-n})^+.$$

One may check the commutation relations either in the current algebra language or in the oscillator modes language.

The central element, k , of the algebra is represented by one. Therefore, the highest weight should be either

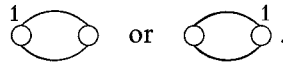

This can be read directly on the definitions of the operators; due to the presence of zero modes in the Fubini-Veneziano field, the field $e(z)$ contains a term $z^{\alpha p}$. This term is well defined if and only if the momentum $|p\rangle$ is integral, i.e. if $|p\rangle$ belongs to the weight lattice of A_1 . A highest weight vector must be annihilated by the two simple positive roots, e_0^+ and e_1^- :

$$\begin{aligned}
 e_0^+ |p\rangle &= \oint \frac{dz}{2i\pi} e^{\alpha \sum_{n>0} x - n \frac{z^n}{n}} |p + \alpha\rangle z^{\alpha p} = 0, \\
 e_1^- |p\rangle &= \oint \frac{dz}{2i\pi} e^{-\alpha \sum_{n>0} x - n \frac{z^n}{n}} |p - \alpha\rangle z^{1 - \alpha p} = 0.
 \end{aligned}
 \tag{B1-8}$$

This requires

$$0 \leq p \cdot \alpha \leq 1, \tag{B1-9}$$

leaving only two possibilities, $p=0$ and $p=\alpha/2$, which correspond to the basic and spin representation of $A_1^{(1)}$. Since there is no other highest weight vector, the space \mathcal{H} is not reducible any more. Therefore, the characters are:

$$ch(A_1^{(1)}, k=1)(q) = \frac{\Theta(q)}{\eta(q)}, \tag{B1-10}$$

where $\Theta(q) = \sum q^{\lambda \cdot \lambda/2}$; the sum \sum is over the root lattice, $Z\alpha$, in the basic representation, and over the spin coset, $(Z + 1/2)\alpha$, in the spin representation. η denotes the Dedekind function (A2-19).

We insist once more on the fact that these two representations are exchanged by the outer-automorphism $T_{1/2}$. In other words, all the weights of the basic representation, which are tensors of the horizontal $su(2)$ generated by e_0^+ , e_0^- , and h_0 , are spinors of the oblique $su(2)$ generated by e_1^- , e_{-1}^+ , and $k - h_0$. $T_{1/2}$ acts inside the module as a sort of supersymmetry. It does not commute with the Virasoro energy operator, since $T_{1/2}$ changes the definition of simple roots and hence the definition of the normal ordering (Fig. 1).

Our definition of the Virasoro generators as the Laurent coefficients of the stress tensor $T(z)$ does not coincide with the general definition (A2-4). However, following Goddard, Kent, and Olive, we remark that they have the same central charge, $c=1$. Hence, their difference, which also forms a Virasoro algebra, has central charge zero. Its only unitary representation is the trivial one. Hence, the two Virasoro algebras identify in the representation space. In higher level representations, the difference of these Virasoro generators will not be trivial, and the representations will necessarily involve additional fields besides the free boson field $X(z)$, associated to the Cartan subalgebra.

Consider the string of weights

$$S_A = \left\{ A - m\delta, m \in \mathbb{N}, A = \frac{n\alpha}{2} - \frac{n^2}{4}\delta \right\}.$$

This string carries a representation of the Virasoro algebra no larger than the Fock space of a single boson. On the other hand, the weight $\Omega = (n+2)\alpha/2 + (n+2)^2\delta/4$ which is Weyl-conjugated to A , is also a highest weight of the Virasoro algebra. Therefore, the vector $e_{-\alpha}|\Omega\rangle$, is also a Virasoro highest weight vector, since the Virasoro algebra commutes with g_0 . We recover in this way the fact that Verma module representation $|\Delta = n^2/4, c = 1\rangle$ of the Virasoro algebra are unitary and reducible, and that the partition function of the irreducible representations $|\Delta = n^2/4; c = 1\rangle$ are given by Eq. (A2-19).

B.2. $K = 1$ Representations of the Simply Laced Algebras

The generalization to higher rank algebras is straightforward except for a problem of signs in the definition of the commutators. Consider a simply laced algebra, A_ℓ , D_ℓ or E_ℓ of rank ℓ , and its root lattice A and weight lattice W . The Cartan matrix a_{ij} serves as a metric on A . All the roots have length $(\alpha \cdot \alpha) = 2$. To each element p of W we associate a vacuum vector $|p\rangle$, normalized to one, $\langle p|p\rangle = 1$. Over each of these vacua, we construct a Fock space in ℓ boson fields, $X^i(z)$, $i = 1$ to ℓ . The union of the resulting Fock spaces is the Hilbert space (A4-13)

$$\mathcal{H} = \text{Fock}(X^i) \otimes W. \tag{B2-1}$$

We consider now ℓ Fubini-Veneziano fields, $X^i(z)$, $i = 1$ to ℓ . The operators $P^i(z) = iz\partial_z X^i(z)$ represent the Heisenberg, or affine Cartan subalgebra, and the vertex operators, (A4-23),

$$U(\alpha, z) = \text{:exp}(i\alpha \cdot X(z))\text{:}, \tag{B2-2}$$

where α is a root of the A, D, E algebra, represent the current algebra up to the Klein sign factor. Indeed, from the O.P.E. of the $U(\alpha, z)$ fields, see Eq. (A4-23), one deduces that the modes U_n^α , and h_m^i ,

$$\begin{aligned} U_n^\alpha &= (U_{-n}^{-\alpha})^+ = \oint \frac{dz}{2\pi i} z^n U(\alpha, z), \\ h_m^i &= \oint \frac{dz}{2\pi i} z^m h^i(z) = \oint \frac{dz}{2\pi i} z^m P^i(z) \end{aligned} \tag{B2-3}$$

satisfy:

$$U_m^\alpha U_n^\beta - (-1)^{\alpha\beta} U_n^\beta U_m^\alpha = \begin{cases} 0, & \alpha \cdot \beta > 0, \\ U_{m+n}^{\alpha+\beta}, & \alpha \cdot \beta = -1, \\ \alpha \cdot h_{m+n} + m\delta_{m+n,0}, & \alpha = -\beta. \end{cases} \tag{B2-4}$$

These pseudo-commutation relations differ from commutators by a sign depending on the pair (α, β) .

To compensate this sign, Frenkel and Kac [14] have introduced a two cocycle $\varepsilon(\alpha, \beta)$:

$$\varepsilon : A \otimes A \rightarrow \{ +1, -1 \}, \tag{B2-5}$$

which can be constructed in the following way:

i) order the simple roots, α_i , of the finite Lie algebra in an arbitrary way and define $\varepsilon(\alpha_i, \alpha_j)$ in terms of the Cartan matrix a_{ij} by:

$$\varepsilon(\alpha_i, \alpha_j) = \begin{cases} -1, & \text{if } i=j, \\ +1, & \text{if } i < j, \\ (-1)^{a_{ji}}, & \text{if } i > j, \end{cases} \tag{B2-6}$$

ii) extend this definition to the whole root lattice by the bimultiplicativity law:

$$\begin{cases} \varepsilon(\alpha + \beta, \gamma) = \varepsilon(\alpha, \gamma)\varepsilon(\beta, \gamma), \\ \varepsilon(\alpha, \beta + \gamma) = \varepsilon(\alpha, \beta)\varepsilon(\alpha, \gamma). \end{cases} \tag{B2-7}$$

It automatically follows from (A1-7), (A1-8) that

$$\begin{aligned} \varepsilon(\alpha, \beta)\varepsilon(\beta, \alpha) &= (-1)^{\alpha \cdot \beta}, \\ \varepsilon(\alpha, \alpha) &= (-1)^{\alpha \cdot \alpha/2}. \end{aligned} \tag{B2-8}$$

The $\varepsilon(\alpha, \beta)$ trivially satisfy the cocycle condition

$$\varepsilon(\alpha, \beta)\varepsilon(\alpha + \beta, \gamma) = \varepsilon(\alpha, \beta + \gamma)\varepsilon(\beta, \gamma) \tag{B2-9}$$

and define a central extension \tilde{A} of the abelian group A by $\{ +1, -1 \}$,

$$1 \rightarrow \{ +1, -1 \} \rightarrow \tilde{A} \rightarrow A \rightarrow 1$$

with the definition

$$\begin{aligned} \alpha, \beta \in A, \quad a, b \in \pm 1, \\ (\alpha, a) \cdot (\beta, b) = (\alpha + \beta, \varepsilon(\alpha, \beta)ab). \end{aligned}$$

Let us now extend ε to $A \times W \rightarrow \{ +1, -1 \}$. Each equivalence class of W/A has a single representation inside the first affine Weyl chamber of A which is the highest weight λ^a of one of the fundamental representations of the algebra. If λ belongs to the equivalence class of λ^a , we define $\varepsilon_*(\alpha, \lambda)$ by:

$$\varepsilon_*(\alpha, \lambda) = \varepsilon(\alpha, \lambda - \lambda^a). \tag{B2-10}$$

Now, the Kac-Moody algebra is represented by the currents $V(\alpha, z)$:

$$V(\alpha, z) = U(\alpha, z)\hat{\varepsilon}_\alpha, \tag{B2-11}$$

where the cocycle operators $\hat{\varepsilon}_\alpha$ act on the state $|p\rangle$ as:

$$\hat{\varepsilon}_\alpha |p\rangle = \varepsilon_*(\alpha, p) |p\rangle. \tag{B2-12}$$

By construction, the $\hat{\varepsilon}_\alpha$ remove the sign factor in Eq. (B2-4). Indeed, from Eqs. (B2-8) and (B2-9), the new O.P.E. reads,

$$V(\alpha, z)V(\beta, w) = U(\alpha, z)U(\beta, w)\varepsilon(\alpha, \beta)\hat{\varepsilon}_{\alpha+\beta} \tag{B2-13}$$

from which it follows that the V_n^α and P_n^i modes close by commutation. The introduction of the cocycle operators modify the hermiticity properties. The V_n^α modes are now defined for α positive by:

$$V_n^\alpha = \oint \frac{dz}{2\pi i} z^n V(\alpha, z), \tag{B2-14a}$$

and for α negative by

$$V_n^\alpha = (V_{-n}^{-\alpha})^+ = \oint \frac{dz}{2\pi i} z^n V(\alpha, z). \tag{B2-14b}$$

Again, it is easy to check that the only highest weight vectors in \mathcal{H} are the fundamental weight vector $|\lambda^\alpha\rangle$ of the finite algebra. Therefore, \mathcal{H} is only finitely reducible and the string functions are equal to

$$c(q) = (\eta(q))^{-\ell}. \tag{B2-15}$$

The vertex operator $\exp(i\alpha X)$ first appeared in the dual string theory. This construction, including the necessary sign factor, is due to Frenkel and Kac [14] and to Segal [15]. It was explained very clearly to physicists by Goddard and Olive [28] and is incorporated in the heterotic string theory [20]. Of course, many other constructions, differing by the choice of the gradation, are possible [16, 25].

Specializing to the $D_n^{(1)}$ algebra, we note that it has only four level one representations, the scalar, the vector and the two spinors. They can be shifted one into another by changing the normal ordering in the Virasoro operators or, equivalently, the horizontal D_n algebra. The energy of the vacuum of the scalar, the vector and the two spinors are respectively:

$$\Delta = 0, 1/2, n/8. \tag{B2-16}$$

In the particular case of $D_4^{(1)}$, the outer-automorphism which exchanges the tensor and spinor representations, is an automorphism of D_4 , not only of $D_4^{(1)}$, known as the triality:

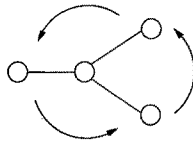

It follows that the vector and the spinor representations of $D_4^{(1)}$ have the same character; one recovers, using (B3-11), the famous identity of Jacobi:

$$\prod_n (1 + q^{n+\frac{1}{2}})^8 - \prod_n (1 - q^{n+\frac{1}{2}})^8 = 16\sqrt{q} \prod_n (1 + q^n)^8. \tag{B2-17}$$

B.3. $K=1$ Representations of the $B_n^{(1)}$ Algebra

The simplest example of non-simply laced affine algebra is $B_n^{(1)}$. The Dynkin diagram of the $B_n = so(2n+1)$ algebra has a double link (see Table 1). If we denote by ε_i an orthonormal frame in R^n the root system of B_n consists of $2n(n-1)$ long

roots, $\pm \varepsilon_i \pm \varepsilon_j$, generating a subalgebra $D_n = so(2n)$, and $2n$ short roots, $\pm \varepsilon_i$, generating the vectorial representation of D_n . The long roots are then normalized to $\alpha \cdot \alpha = 2$, the short ones to 1. The existence of the short roots is at the origin of new complications.

Given n Fubini-Veneziano fields, $X^i(z)$, the Cartan operators $P^i(z)$, and the vertex operators, $\exp(i\alpha X(z))$, associated to the long roots, represent the affine $D_n^{(1)}$ subalgebra of $B_n^{(1)}$. The vertex operators $\exp(i\varepsilon X(z))$ are rotated by the $D_n^{(1)}$ algebra as desired. However, they have several defects:

i) With respect to the free bosonic Virasoro algebra, the short root vertex operators, $\exp(i\varepsilon X(z))$, have as conformal weight one half rather than one.

ii) The O.P.E. of the short root vertex operators, $V(\varepsilon_i, z)V(-\varepsilon_i, w)$, have a simple pole in $(z - w)$ rather than a double one, and furthermore, this expression is antisymmetric rather than symmetric. In other words, the vertex operators, $V(\varepsilon_i, z)$, represent the affine Clifford algebra (see Sect. A.4), rather than the $((A_1)^n)^{(1)}$ subalgebra associated to the short roots.

iii) At the same time, in the level one representation, the central charge of Virasoro algebra [(A2-4) and (A2-7)] associated to $B_n^{(1)}$ exceeds by one half that of the n free Fubini-Veneziano fields.

To cure all these defects at once, we uniformly multiply the short root vertex operators by an auxiliary field, $\Gamma(z)$ say. In order not to impair the fact that the short roots form the vector representation space of the long D_n subalgebra, $\Gamma(z)$ must commute with the bosonic operators. The Γ -field itself should have an odd O.P.E. with a simple pole structure: in this way, the overall O.P.E. is again symmetric and has a double pole as desired. At last, Γ should contribute one half to the Virasoro central charge.

There are two possibilities: the fermionic Neveu-Schwarz or Ramond fields, explicitly defined in Sect. A.4, Eq. (A4-18).

The total Hilbert space of the model becomes in the NS and R cases:

$$\mathcal{H} = \text{Fock}(X^i, \Gamma) \otimes W(B_n). \tag{B3-1}$$

We define a 2-cocycle on the root lattice $\Lambda(B_n)$ as before (B2-5)–(B2-9), with one modification: the order of the roots is no longer immaterial, we order them from long to short. Since the metric g_{ij} on Λ and the Cartan matrix only differ in their last line $g_{ni} = a_{ni}/2$ (A1-9), we still have, when α is long and e short:

$$\varepsilon(\alpha, e)\varepsilon(e, \alpha) = (-1)^{\alpha \cdot e}. \tag{B3-2a}$$

However:

$$\varepsilon(e, f)\varepsilon(f, e) = (-1)^{1 + e \cdot f}. \tag{B3-2b}$$

Bimultiplicativity then yields:

$$\varepsilon(\alpha, \beta)\varepsilon(\beta, \alpha) = (-1)^{\alpha \cdot \beta + \alpha^2 \beta^2}. \tag{B3-3}$$

Thus, since $\alpha^2 \cdot \beta^2$ is odd only when both α and β belong to the vector coset $(e + \Lambda(D_n))$, we get an additional minus sign only in that case. This sign just provides for the symmetrization of the auxiliary NSR operators that we attach to the short roots [compare (A4-20), (A4-25), (B2-4), and (B3-4)]. Thus, to the short

roots, we associate the currents:

$$zJ(e, z) = z^{e^2/2} \circ \exp(ie \cdot X(z)) \circ \Gamma(z) \hat{e}_e, \tag{B3-4}$$

and to the long roots, the Frenkel-Kac currents (B2-11).

The weight lattice W of the B_n algebra splits with respect to \mathcal{A} into two classes:

$$W(B_n) = \mathcal{A}(B_n) \cup (s + \mathcal{A}(B_n)),$$

where s denotes the highest weight of the spin representation. The lattice \mathcal{A} is, of course, integral, therefore if p belongs to \mathcal{A} the scalar product $e \cdot p$ is integral. On the contrary, the scalar product $e \cdot s = 1/2$. Thus, as the zero modes of the Fubini-Veneziano fields contribute $z^{e \cdot p}$ to the currents (B3-4) whereas the prefactor $z^{e \cdot e/2}$ contributes $z^{1/2}$, the operators (B3-4) are well defined iff we use the N.-S. auxiliary field if p belongs to $\mathcal{A}(B_n)$, and the R. field if p is a spinor.

The currents (B2-11) and (B3-4) are primary fields with conformal weight one [(A4-9) and (A4-26)] with respect to the Virasoro algebra:

$$T(z) = T^x(z) + T^r(z).$$

The central charge is $c = n + 1/2$.

In the Hilbert space of the model (B3-1), there are three highest weight vectors. They correspond to the three possible level one modules; the spinor in the Ramond case, the scalar and the vector in the Neveu-Schwarz case. The later being separated by the eigenvalue of the Gliozzi-Scherk-Olive G-parity operator [38] which commutes with the currents (B3-4):

$$G = (-1)^{p^2 + N_F}, \tag{B3-5}$$

where N_F is the fermion number operator.

It follows that \mathcal{H} is finitely reducible, and that the three string functions can readily be evaluated:

$$\begin{aligned} C_{\text{Spin}}^{\text{Spin}}(q) &= q^{-\frac{n-1}{24}} \prod_{k>0} (1+q^k)(1-q^k)^{-n}, \\ C_{\text{Scalar}}^{\text{Scalar}}(q) &= \frac{1}{2} q^{-\frac{2n+1}{48}} \prod_{k>0} (1-q^k)^{-n} \left[\prod_{k \geq 0} (1+q^{k+\frac{1}{2}}) + \prod_{k \geq 0} (1-q^{k+\frac{1}{2}}) \right], \\ C_{\text{Scalar}}^{\text{Vector}}(q) &= \frac{1}{2} q^{-\frac{2n+1}{48}} \prod_{k>0} (1-q^k)^{-n} \left[\prod_{k \geq 0} (1+q^{k+\frac{1}{2}}) - \prod_{k \geq 0} (1-q^{k+\frac{1}{2}}) \right]. \end{aligned} \tag{B3-6}$$

The string functions of the vectorial representation follow from those of scalar representation by the outer-automorphism which rotates the fork of the Dynkin diagram of $B_n^{(1)}$:

$$C_{\text{Vector}}^{\text{Vector}} = C_{\text{Scalar}}^{\text{Scalar}}, \quad C_{\text{Vector}}^{\text{Scalar}} = C_{\text{Scalar}}^{\text{Vector}}. \tag{B3-7}$$

These representations can also be constructed just with fermionic fields. Each long root of the B_n algebra is the sum of two orthogonal short roots: $\alpha = e + f$ with $e \cdot f = 0$. The vertex operator, $V(\alpha, z)$ is then the product of two vertex operators:

$$\circ \exp i\alpha \cdot X \circ = \circ \exp ie \cdot X \circ \circ \exp if \cdot X \circ. \tag{B3-8}$$

Moreover, via the fermion-boson equivalence (see Sect. A.4), the short roots vertex operators, $V(e, z)$, can be written as a linear combination of the $2n$ fermionic fields, $\Gamma_{\pm}^e(z)$:

$$\begin{aligned} \Gamma_+^e(z) &= \frac{1}{\sqrt{2}}(e^{ie \cdot X(z)} + e^{-ieX(z)})_{\circ}, \\ \Gamma_-^e(z) &= \frac{i}{\sqrt{2}}(e^{ie \cdot X(z)} - e^{-ieX(z)})_{\circ}. \end{aligned} \tag{B3-9}$$

Together with the auxiliary fermion $\Gamma(z)$, they form a set of $2n + 1$ fermionic fields. The currents, $J_{\alpha}(z)$ and $J_e(z)$, then become the Bardakci-Halpern currents:

$$J^{ab}(z) = \frac{i}{\sqrt{2}} \Gamma^{[a}(z) \Gamma^{b]}(z) \tag{B3-10}$$

with $a, b = 1$ to $(2n + 1)$. It follows, in particular, that the affine D or B algebra quark model representation (B3-10) is finitely reducible. This property also follows from the factorization of the theta functions of the weight lattice $\Lambda^*(B_n)$:

$$\begin{aligned} \Theta_{\Lambda(B_n)}(q) &= \prod_{k>0} (1 - q^k)^n (1 + q^{k-\frac{1}{2}})^{2n}, \\ \Theta_{s+\Lambda(B_n)}(q) &= 2^n q^{n/8} \prod_{k>0} (1 - q^k)^n (1 + q^k)^{2n}. \end{aligned} \tag{B3-11}$$

This spinor construction first appeared in physics in the work of Bardakci and Halpern [9]. It was rediscovered by Kac and Peterson [39] and by Frenkel [40]. The mixed construction, with one fermion and n bosons can be found, in a somehow cryptic notation!, in Lepowski and Primc [41]. This paper was later translated by Alvarez, Mangano, and Windey [42].

B.4. $K = 1$ Representations of $D_{n+1}^{(2)}$, First Construction

The twisted algebra $D_{n+1}^{(2)}$ contains $B_n^{(1)}$ as a subalgebra and can be represented in a similar way. The root system of $D_{n+1}^{(2)}$ decomposes into two pieces:

The roots, which are at an integral δ -level, are isomorphic to the roots of the $B_n^{(1)}$ affine algebra. They can be represented by the currents $J(\alpha, z)$ and $J(\varepsilon^i, z)$, defined in the previous section. In particular, the currents associated to the roots contain an auxiliary fermionic field, Γ say.

The real roots which are at half integral δ -level, are isomorphic to the short real roots of $B_n^{(1)}$. Therefore, their associated currents can be represented by the product of vertex operators $V(\varepsilon^i, z)$ (those which also contribute to the $B_n^{(1)}$ currents), by another auxiliary fermionic field, Γ^* say. But, in order that the integer and the half integer currents be simultaneously single valued, the two fermionic fields, Γ and Γ^* , must be of opposite type. Then, the half integer imaginary roots, $(Z + 1/2)\delta$, can be represented by the product of the two auxiliary fermions, $\Gamma(z)\Gamma^*(z)$. As Γ and Γ^* are of opposite type, the $(Z + 1/2)$ modes of these currents are well-defined.

It is now easy to check that these currents close under O.P.E., and therefore that they represent the $D_{n+1}^{(2)}$ with central charge one.

Furthermore, the currents will be single valued if and only if $\Gamma(z)$ is of N.-S. (R.) type if the momentum p^i belongs to the tensor (spinor) coset of the weight lattice W of B_n . The irreducibility of the representation spaces:

$$\mathcal{H} = \text{Fock}(X^i, \Gamma, \Gamma^*) \otimes \left[A(B_n) + \begin{Bmatrix} 0 \\ s \end{Bmatrix} \right] \tag{B4-1}$$

which is the tensorial product of the Fock spaces of the boson (X^i) and fermion (Γ and Γ^*) by one of these cosets is directly shown by looking at the possible highest weight vectors. Note that $D_{n+1}^{(2)}$ only has 2 level one modules. This can be read from the Dynkin diagram and from the fact that the GSO projector (B3-4) does not commute with the currents corresponding to the half integral δ levels. It follows that the improved string functions of the level one representations of $D_{n+1}^{(2)}$ are all equal to:

$$C(q) = q^{-\frac{n+1}{24} + \frac{1}{16}} \prod_{k>0} \frac{(1+q^k)(1+q^{k-\frac{1}{2}})}{(1-q^k)^n}. \tag{B4-2}$$

The generalization of this construction to the other twisted algebras involves non-independent auxiliary fermionic fields; it is presented in the following sections.

It is, however, easy to generalize this construction to the other homogeneous gradations of $D_{n+1}^{(2)}$. Indeed, all the Kac weights attached to the Dynkin diagram of these algebras are equal to 1 (Table 2). According to the discussion (A1-15), we may associate a homogeneous gradation to each simple root and keep as horizontal algebra the subalgebra $B_p \oplus B_q$, with $p+q=n$. We represent the integrally graded subalgebra by the currents of Sect. B.3 and the half integral currents, which form a (vector, vector) representation of $B_p \oplus B_q$ by the product of the vector currents:

$$U(e, z) = z^{e^2/2} \circ \exp(ie \cdot X) \circ \hat{e}_e \tag{B4-3}$$

of each algebra. These currents are well defined if and only if one carries an integral power of z when the other is half integral. When p or q vanishes, the construction reduces to the previous one. The cocycle is the product of the cocycles on B_p and B_q . The Hilbert space is the product of a Fock space with $p+q=n$ bosons, one NS and one R field, by one of the cosets (vector spinor) or (spinor vector).

We obtain in this way the two level one modules of $D_{n+1}^{(2)}$ in these gradations.

B.5. Fermionic Construction

of the Twisted Kac-Moody Algebras $A_\ell^{(2)}$, $D_{2\ell+1}^{(2)}$, and $E_6^{(2)}$

In this section, a fermionic construction of the twice twisted Kac-Moody algebras due to Lepowski [24], is presented. In keeping with the spin-statistic principle this construction is fermionic in two respects:

*) It only involves odd moded Fubini-Veneziano fields $Y^{(-)}$ (A4-31), which are equivalent to a mixture of interacting Neveu-Schwarz and Ramond fields obeying anticommutation relations (the statistical aspect of fermions).

*) In the absence of zero modes, the group lattice Λ (B1-4) is replaced by the Dirac spinor representation of an $SO(M)$ algebra, and the cocycles (B2-5)–(B2-13) are replaced by a set of Dirac (Clifford) matrices Γ_α associated to the simple roots as shown in Fig. 4 (the spin aspect of fermions).

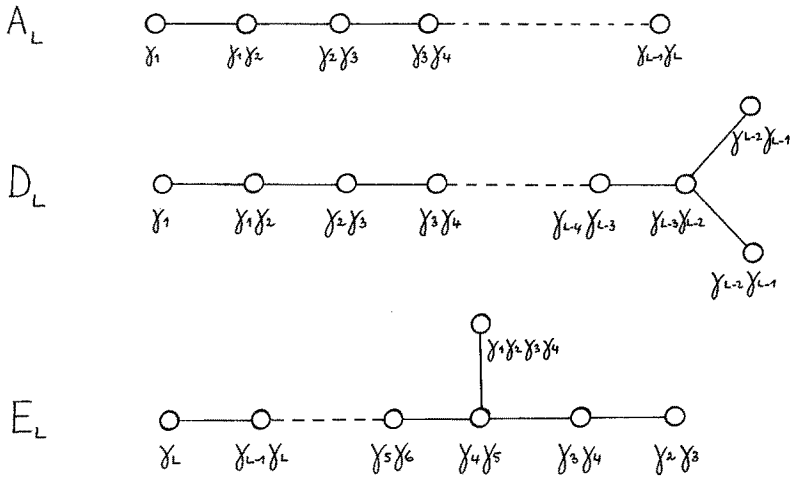

Fig. 4. Dirac matrices involved in the Fermionic construction of the 2-twisted algebras (B5-14)

This fermionic construction of $A_\ell^{(2)}$ will be used again in the next section as a piece of a new bosonic construction of the twisted algebras.

Let us first consider the A_ℓ case. Let σ be the involution, $\sigma = -1$, of the root diagram of the algebra $A_\ell = SU(\ell + 1)$. The σ -invariant generators,

$$e_\alpha + e_{-\alpha} \tag{B5-1}$$

generate the subalgebra $SO(\ell + 1)$, whereas the generators

$$e_\alpha - e_{-\alpha}, \quad h_\alpha \tag{B5-2}$$

generate the orthogonal complement corresponding to the irreducible traceless symmetric tensor of $SO(\ell + 1)$.

Let Λ denote the root lattice of A_ℓ . The quotient $\Lambda/2\Lambda$ is isomorphic to the finite group $(\mathbb{Z}_2)^\ell$

$$\frac{\Lambda}{2\Lambda} \simeq (\mathbb{Z}_2)^\ell. \tag{B5-3}$$

Let χ denote the Dirac spinor of $SO(\ell)$, a vector space of dimension $2^{\lfloor \ell/2 \rfloor}$. Consider the corresponding Dirac matrices $\gamma_i, i = 1, \dots, \ell$ generating the Clifford algebra

$$\gamma_i \in \text{End}(\chi), \tag{B5-4}$$

$$\gamma_i \gamma_j + \gamma_j \gamma_i = -2\delta_{ij}. \tag{B5-5}$$

There is a natural application Γ of the roots of $\Lambda/2\Lambda$ into $\text{End}(\chi)$:

$$\Gamma\left(\sum_i n_i \alpha_i\right) = \gamma_1^{\hat{n}_1} \prod_{i=2}^{\ell} (\gamma_{i-1} \gamma_i)^{\hat{n}_i}, \tag{B5-6}$$

where $\hat{n}_i \in \{0, +1\}$, α_i denote the simple roots of A_ℓ and $\tilde{\alpha} = \sum n_i \alpha_i$ is a distinguished representative of his class in $\Lambda/2\Lambda$. The product on the right-hand side is ordered in i , increasing from left to right.

We can now define a cocycle $\varepsilon(\alpha, \beta)$ through

$$\begin{aligned} \varepsilon \circ A/2A \otimes A/2A &\rightarrow \{+1, -1\}, \\ \Gamma_\alpha \Gamma_\beta &= \varepsilon(\alpha, \beta) \Gamma_{\alpha+\beta}. \end{aligned} \tag{B5-7}$$

By itself this definition of $\varepsilon(\alpha, \beta)$ imply the cocyclicity (B2-9). Furthermore, we have chosen (B5-6) in such a way that on the simple roots the $\varepsilon(\alpha_i, \alpha_j)$ satisfy the relations (B2-8)

$$\varepsilon(\alpha, \alpha) = (-1)^{\alpha \cdot \alpha/2}, \tag{B5-8a}$$

$$\varepsilon(\alpha, \beta) \varepsilon(\beta, \alpha) = (-1)^{\alpha \cdot \beta}. \tag{B5-8b}$$

One may verify bimultiplicativity

$$\varepsilon(\alpha + \beta, \gamma) = \varepsilon(\alpha, \gamma) \varepsilon(\beta, \gamma), \quad \varepsilon(\alpha, \beta + \gamma) = \varepsilon(\alpha, \beta) \varepsilon(\alpha, \gamma), \tag{B5-9}$$

and hence, (B5-8) extends to every pair $(\alpha, \beta) \in A/2A \otimes A/2A$.

Let us now introduce ℓ odd graded Fubini-Veneziano fields Y_{-}^i as in (A4-31) and consider the tensor product of the Fock space of the Y fields by the spin space χ :

$$\mathcal{H} = \text{Fock}(Y^i) \otimes \chi. \tag{B5-10}$$

The currents

$$\begin{aligned} h^i(z) &= \frac{1}{z} P^i_{(-)}(z) = i\sqrt{2} \partial_z Y^i_{(-)}(z), \\ U^i_{(-)}(\alpha, z) &= \frac{1}{2z} \circ \exp(i\alpha \cdot Y_{(-)}(z)) \circ \Gamma(\alpha), \\ \alpha &\in A_+(A_\ell), \quad \alpha \cdot \alpha = 2, \end{aligned} \tag{B5-11}$$

represent the affine algebra $A_\ell^{(2)}$, twisted by the root automorphism $\sigma = -1$.

The modes U_n^α ,

$$U_n^\alpha = \oint \frac{dz}{2\pi i} z^n U(\alpha, z) \tag{B5-12a}$$

for α positive and

$$U_n^\alpha = (U_{-n}^{-\alpha})^+ \tag{B5-12b}$$

for α negative, are even and odd. The even modes close by themselves and represent the subalgebra $SO(\ell + 1)^{(1)}$, i.e. $B_p^{(1)}$ if $\ell = 2p$ or $D_p^{(1)}$ if $\ell = 2p - 1$. The odd modes U_{2n+1}^α together with the odd modes h_{2n+1}^i ,

$$h_n^i = \oint \frac{dz}{2i\pi} z^{n-1} P^i_{(-)}(z) \tag{B5-13}$$

form a representation of the horizontal algebra $SO(\ell + 1)$ which, together with the even modes complete the construction of the twisted algebra $A_\ell^{(2)}$. The currents $h^i(z)$ and $U^i_{(-)}(\alpha, z)$ are primary fields, with conformal weight one, with respect to the Virasoro algebra $L^{(-)}$ (A4-39) whose central charge if ℓ .

The same construction (B5-11) can be applied to the other simply laced algebras E_ℓ and D_ℓ . We just need to modify (B5-6) and to choose the image Γ of the simple roots as shown in Fig. 4. The set of Γ_α matrices is defined from the Γ_{α_i} associated to the simple roots α_i . Namely, if $\alpha = \sum n_i \alpha_i$,

$$\Gamma(\alpha) = \prod_{i=1}^{\ell} \Gamma(\alpha_i)^{\tilde{n}_i}, \tag{B5-14}$$

where $\tilde{n}_i \equiv n_i \pmod{[2]}$, $\tilde{n}_i \in \{0, +1\}$. The product is also ordered in i from left to right.

In the case of $D_{2\ell}$, E_7 , E_8 the automorphism is inner, yielding a fermionic construction of the $D_{2\ell}^{(1)}$, $E_7^{(1)}$, $E_8^{(1)}$ in which the integrally graded subalgebra is isomorphic to $(D_\ell + D_\ell)^{(1)}$, $A_7^{(1)}$, $D_8^{(1)}$.

In the case of A_ℓ , $D_{2\ell+1}$, E_6 the automorphism is outer, yielding a homogeneous construction of the $A_\ell^{(2)}$, $D_{2\ell+1}^{(2)}$, $E_6^{(2)}$ in which the integrally graded subalgebra is respectively $SO(\ell+1)^{(1)}$, $(B_\ell + B_\ell)^{(1)}$, and $C_4^{(1)}$.

The character of L_0 in the carrier space (B4-10) is

$$\text{Tr}_{\mathcal{H}} q^{\bar{L}_0} = 2^{[M/2]} q^{\frac{\ell}{16} - \frac{\ell}{24}} \prod_{k>0} \frac{1}{(1 - q^{k - \frac{1}{2}})^{\ell}}, \tag{B5-15}$$

where ℓ is the rank of the algebra and $M = \ell$ in cases A_ℓ , E_ℓ or $M = \ell - 1$ in case D_ℓ (see Fig. 4).

Let us verify that \mathcal{H} is irreducible. The whole Fock space $\text{Fock}(x^i_{2n+1})$ is necessary to the definition of the currents. As the highest weight vector must be annihilated by the modes h_1^i , it must be a vacuum vector. The question is then the irreducibility of the $SO(M)$ Dirac spinor χ . By itself χ is the lowest eigenspace of L_0 and must therefore carry a representation of the horizontal algebra g_0 . The choice of the imbedding of $SO(M)$ in g_0 proves irreducibility and specifies the construction.

$A_{2\ell}^{(2)}$, $E_6^{(2)}$, and $E_8^{(1)}$ have a unique level one module. In these cases, $M = 2\ell, 6$, and 8 ; and χ is respectively identified with the irreducible Dirac spinor of $SO(2\ell+1)$, the fundamental of C_4 and the vector of D_8 .

$A_{2\ell-1}^{(2)}$ has two level one modules. Indeed, $SO(2\ell-1)$ has two imbedding in $SO(2\ell)$ such that the Dirac spinor χ of $SO(2\ell-1)$ is identified with one or the other chiral spinors of $SO(2\ell)$.

$E_7^{(1)}$ also has two level one modules. They differ by the identification of χ as the 8 or $\bar{8}$ of $SU(8)$.

In the case of $D_{2\ell+1}^{(2)} \supset B_\ell * B_\ell$, we identify χ as the spinor of either B_ℓ , yielding the two inequivalent basic modules.

At last, in $D_{2\ell}^{(1)} \supset D_\ell * D_\ell$ we identify χ with a chiral spinor of either chirality in either algebra.

B.6. Bosonic Construction

of the Twisted Kac-Moody Algebras $A_{2\ell-1}^{(2)}$, $D_{\ell+1}^{(2)}$, and $E_6^{(2)}$

In this section we present an alternative bosonic construction of the twisted algebras $g_N^{(v)} = A_{2\ell-1}^{(2)}$, $D_{\ell+1}^{(2)}$, $E_6^{(2)}$, $D_4^{(3)}$, based on the outer diagram automorphism of $g_N = A_{2\ell-1}$, $D_{\ell+1}$, E_6 , and D_4 centralizing $g_0 = C_\ell$, B_ℓ , F_4 , and

G_2 . The rank of g_0 is smaller than the rank of g_N by p units,

$$p = \text{rank}(g_N) - \text{rank}(g_0) = \text{rank}(g_N^{(1)}) - \text{rank}(g_N^{(\tau)}). \tag{B6-1}$$

However, in the affine Kac-Moody root diagram, the roots are not lost, they are just reorganized: the multiplicity of the root δ drops to $\text{rank}(g_0)$ whereas a new imaginary root $+\delta/\tau$ appears with multiplicity $p/(\tau - 1)$. Also, the short roots of g_0 are repeated every δ/τ [(A1-26)–(A1-28)].

$$\begin{aligned} A^{re}(g_N^{(\tau)}) &= \{ \Delta_{\text{long}}(g_0) + \mathbb{Z}\delta \} \\ &\cup \{ \Delta_{\text{short}}(g_0) + \mathbb{Z}\delta/\tau \}. \end{aligned} \tag{B6-2}$$

The long integrally graded subalgebra $g_L^{(1)}$ is respectively $(A_1^{(1)})^{(1)}$, $D_\ell^{(1)}$, $D_4^{(1)}$, and $A_2^{(1)}$. We read from the Dynkin diagram of g_0 that its short simple roots generate a regular subalgebra of type A_p , and we also note that g_0 has $ph/(\tau - 1)$ short roots organized into $p(p + 1)/2$ representations of g_L ; h denotes the common Coxeter number of g_N and g_0 (Table 7).

Dropping the case of $D_4^{(3)}$ till Sect. B.8, we are going to associate each of these representations to a positive root of the “short” A_p in the following way:

Let $\alpha_i^{(\ell)}$ and $\alpha_j^{(s)}$ denote the long, $\alpha^{(\ell)} \cdot \alpha^{(\ell)} = 2$, and short, $\alpha^{(s)} \cdot \alpha^{(s)} = 1$, simple roots of g_0 . We map $A(g_0)$ onto $A_+(A_p)$:

$$\begin{aligned} \varrho : A(g_0) &\rightarrow A_+(A_p), \\ \alpha &\rightarrow \tilde{\alpha} \end{aligned} \tag{B6-3}$$

by:

$$\begin{aligned} \alpha &= \sum_{i=1}^{N-p} m_i \alpha_i^{(\ell)} + \sum_{j=N-p+1}^N n_j \alpha_j^{(s)}, \\ \tilde{\alpha} &= \sum_{j=N-p+1}^N \tilde{n}_j \alpha_j^{(s)}, \end{aligned} \tag{B6-4}$$

with $\tilde{n}_j \in \{0, +1\}$ and $\tilde{n}_j \equiv n_j [2]$. Note that $(\alpha \cdot \beta \pm \tilde{\alpha} \cdot \tilde{\beta})$ is always integral.

If we represent the long integrally graded subalgebra $g_L^{(1)}$ of $g_N^{(\tau)}$ by the Frenkel-Kac currents (B2-13), the Frenkel-Kac currents associated to the short roots will have the wrong conformal weight and O.P.E., as explained in Sect. B.3. We are going to complete the Frenkel-Kac currents associated to the short roots by the Lepowski currents (B5-11) of the fermionic construction of $A_p^{(2)}$ by associating one rescaled Lepowski current to each representation of g_L .

Table 7. The horizontal (g_0), short (A_p), and long (g_L) regular subalgebras involved in the Bosonic construction of $g_N^{(\tau)}$ (B6-1)

g_N	$A_{2n-1} = SU(2n)$	$D_{n+1} = SO(2n+2)$	$E_6^{(2)}$	$D_4^{(3)}$
g_0	$C_n = Sp(2n)$	$B_n = SO(2n+1)$	F_4	G_2
A_p	$A_{n-1} = SU(n)$	A_1	A_2	A_2
g_L	$(A_1)^n$	$D_n = SO(2n)$	D_4	A_2

The construction is the following. Consider $(N - p)$ even graded Fubini-Veneziano fields and p odd graded ones:

$$X^i_{(+)}(z) = q - ip \operatorname{Log} z^2 - i\sqrt{2} \sum_{2\mathbb{Z}} x^i_{-n} \frac{z^n}{n}, \tag{B6-5}$$

$$Y^j_{(-)}(z) = -i\sqrt{2} \sum_{2\mathbb{Z}+1} x^j_{-n} \frac{z^n}{n}.$$

Let W denote the weight lattice of g_0 . We consider the Hilbert space

$$\mathcal{H} = \operatorname{Fock}(X^i, Y^i) \otimes W(g_0). \tag{B6-6}$$

We want to define as in Sects. B.2 and B.3, a map ε ,

$$\varepsilon: \mathcal{A} \otimes \mathcal{A} \rightarrow \{+1, -1\}. \tag{B6-7}$$

In the case of A, D, E the Jacobi identity implies that the Chevalley structure constants (A1-21) form a two-cocycle. However, in the case of Lie algebra with more than one short simple root, they do not, since there occur Jacobi identities with three non-vanishing double commutators. We modify the construction (B2-6)–(B2-9) as follows:

i) Order the simple root of g_0 from long to short and set

$$\varepsilon(\alpha_i, \alpha_j) = \begin{cases} -1, & \text{if } i=j, \\ +1, & \text{if } i < j, \\ (-1)^{a_{ji}}, & \text{if } i > j. \end{cases} \tag{B6-8}$$

ii) Extend their definition to the whole lattice by the distorted bimultiplicativity law:

$$\varepsilon(\alpha, \beta + \gamma) = \varepsilon(\alpha, \beta)\varepsilon(\alpha, \gamma), \tag{B6-9a}$$

$$\varepsilon(\alpha + \beta, \gamma) = \varepsilon(\alpha, \gamma)\varepsilon(\beta, \gamma)\xi(\alpha, \beta; \gamma), \tag{B6-9b}$$

with

$$\xi(\alpha, \beta; \gamma) = (-1)^{\overline{(\alpha+\beta-\tilde{\alpha}-\tilde{\beta})} \cdot \tilde{\gamma}}. \tag{B6-10}$$

ξ measures the deviation of q from being a homomorphism of additive groups. It is well defined since $(\overline{\alpha+\beta-\tilde{\alpha}-\tilde{\beta}})$ always belongs to $2\mathcal{A}(A_p)$.

The ε satisfy the distorted cocycle relation

$$\varepsilon(\alpha, \beta + \gamma)\varepsilon(\beta, \gamma) = \varepsilon(\alpha, \beta)\varepsilon(\alpha + \beta, \gamma)\xi(\alpha, \beta; \gamma) \tag{B6-11}$$

and,

$$\varepsilon(\alpha, \beta)\varepsilon(\beta, \alpha) = (-1)^{\alpha \cdot \beta + \tilde{\alpha} \cdot \tilde{\beta}}. \tag{B6-12}$$

The last equation can be proven by recursion. (B6-12) is true on the simple roots by construction (B6-8). Furthermore, either side of (B6-12) satisfies the distorted bimultiplicativity law (B6-9b). Restricted to the sublattice $\mathcal{A}(g_L)$, q is a homomorphism and ε coincides with the cocycle of Sect.. B.2.

We extend ε to $A \times W$ as usual [Eq. (B2-10)] and define on \mathcal{H} (B6-6) the operators:

$$\hat{\varepsilon}_\alpha : \hat{\varepsilon}_\alpha |p\rangle = \varepsilon(\alpha, p) |p\rangle. \tag{B6-13}$$

We represent

*) the Cartan currents by (B2-13)

$$h_{(+)}^i(z) = \frac{i}{2} \partial_z X_{(+)}^i(z). \tag{B6-14a}$$

These currents only have even graded modes.

*) The currents associated to the roots $(n + 1/2)\delta$, whose degeneracy is p , by the odd moded fields

$$h_{(-)}^j(z) = \frac{i}{2} \partial_z Y_{(-)}^j(z). \tag{B6-14b}$$

*) The currents associated to the positive roots of g_0 by

$$J(\alpha, z) = z^{2\alpha-1} U_{(+)}(\alpha, z) U_{(-)}(\tilde{\alpha}, z) \hat{\varepsilon}_\alpha = V(\alpha, z) \hat{\varepsilon}_\alpha, \tag{B6-14c}$$

where $U_{(+)}$ and $U_{(-)}$ are the even and odd moded vertex operators defined by (A4-43) and (A4-33). If α^ℓ is a long root, $\tilde{\alpha} = 0$ and $J(\alpha^\ell, z)$ only has even modes. If α^s is a short root, $J(\alpha^s, z)$ has even and odd modes. The operators $U_{(-)}(\alpha, z)$ are rescaled Lepowski currents (B5-11) which play the role of a set of non abelian interacting fermions. The O.P.E. of currents is

$$V(\alpha, z) V(\beta, w) = (z^2 - w^2)^{\alpha \cdot \beta} \left(\frac{z-w}{z+w} \right)^{\tilde{\alpha} \cdot \tilde{\beta}} : V(\alpha, z) V(\beta, w) :. \tag{B6-15}$$

Under the exchange $(\alpha, z) \rightarrow (\beta, w)$, this O.P.E. changes by a factor $(-1)^{\alpha\beta + \tilde{\alpha}\tilde{\beta}}$. The ε operators now play a double role. On the one hand, by Eq. (B6-12), they turn the commutators of the modes of the currents $J(\alpha, z)$ and $J(\beta, w)$ into a Cauchy integral (A4-5). On the other hand, when $\tilde{\alpha} \cdot \tilde{\beta} > 0$, i.e. when $(\tilde{\alpha} + \tilde{\beta}) \neq \tilde{\alpha} + \tilde{\beta}$, there may exist a pole at $z = -w$. This induces a parasite sign factor in the residue, since:

$$U_+(\alpha, -w) = U_+(\alpha, w) (-1)^{2\alpha \cdot p}. \tag{B6-16}$$

This sign is just compensated by the factor $\xi(\alpha, \beta; p)$ in the composition law (B6-11).

The fields (B6-14) are primary fields with conformal weight one with respect to the Virasoro algebra defined as the sum of the free Virasoro algebra (A4-45) of the even and odd oscillators.

As usual, we define the modes by

$$\alpha \in \Delta_+(g_0), \quad J_n^\alpha = (J^{-\alpha} -_n)^+ = \oint \frac{dz}{2\pi i} z^n J(\alpha, z), \tag{B6-17}$$

$$h_{(\pm)n} = \oint \frac{dz}{2\pi i} z^n h_{(\pm)}(z)$$

which close by commutation.

A highest weight p in \mathcal{H} is annihilated by all the positive simple roots of g_0 (thus all its Dynkin weights are positive or zero), and by Θ , the level $\delta/2$ simple root, which implies

$$|p \cdot \Theta| < 1 \tag{B6-18}$$

as a generalization of (B1-8). Therefore, in keeping with the Dynkin diagram rules (A1-6), \mathcal{H} has two components in case $A_{2\ell-1}^{(2)}$ with $p=0$ or p the highest weight of the \square representation of C_ℓ , two in $D_{\ell+1}^{(2)}$ with p the scalar or the spinor highest weight of B_ℓ , and a single one, $p=0$, in $E_6^{(2)}$.

In each case, there is an unique string function:

$$c(q) = q^{\frac{p}{16} - \frac{N}{24}} \prod_{n>0} (1 - q^n)^{p-N} (1 - q^{n-\frac{1}{2}})^{-p}. \tag{B6-19}$$

It should be noted that this construction reduces in the case of $D_{\ell+1}^{(2)}$ to the construction of Sect. B.4.

B.7. The Bosonic Construction of the $A_{2\ell}^{(2)}$ Twisted Algebra

The $A_{2\ell}^{(2)}$ twisted algebra contains the $A_{2\ell-1}^{(2)}$ twisted subalgebra and can be represented in a similar way. There exists a gradation of $A_{2\ell}^{(2)}$ (A1-30) corresponding to an outer-automorphism of $A_{2\ell}$ of order four, which extends the homogeneous gradation of the $A_{2\ell-1}^{(2)}$ subalgebra. The horizontal algebra is C_ℓ and the real root system (B6-2) is simply completed by the \square representation of C_ℓ at the levels $(2\mathbb{Z} + 1)\delta/4$.

$$\begin{aligned} \Delta_{re} = & \{ \alpha + \mathbb{Z}\delta, \alpha \in \Delta_\ell(C_\ell) \} \\ & \cup \{ \alpha + \mathbb{Z}\delta/2, \alpha \in \Delta_s(C_\ell) \} \\ & \cup \left\{ \frac{\alpha}{2} + (2\mathbb{Z} + 1)\delta/4, \alpha \in \Delta_\ell(C_\ell) \right\}. \end{aligned} \tag{B7-1}$$

The imaginary roots of $A_{2\ell-1}^{(2)}$: $\mathbb{Z}\delta$ with degeneracy ℓ and $(\mathbb{Z} + 1/2)\delta$ with degeneracy $(\ell - 1)$ are completed by an additional imaginary root $(\mathbb{Z} + 1/2)\delta$ corresponding to the C_ℓ singlet of (A1-30). To each imaginary root, we associate a free bosonic field: $\ell X^i_{(+)}$ and $(\ell - 1)Y^j_{(-)}$ as in Sect. B.6, plus a new odd field $Z_{(-)}$. The total central charge of the Virasoro algebra is 2ℓ and the energy of the vacuum is $\ell/16$.

We represent the imaginary roots by the currents (B6-14):

$$h^i_+ = i\partial_z X^i_{(+)}, \tag{B7-2}$$

$$h^j_- = i\partial_z Y^j_{(-)},$$

$$h_i = i\partial_z Z_{(-)}, \tag{B7-3}$$

the integrally graded long roots by the even Frenkel-Kac currents (A4-43):

$$J(\alpha, z) = zU_+(\alpha, z)\hat{e}_\alpha, \quad \alpha^2 = 2, \tag{B7-4}$$

and the $\mathbb{Z}/2$ graded short roots by the currents (B6-14c):

$$J(\alpha, z) = U_+(\alpha, z)U_-(\tilde{\alpha}, z)\hat{e}_\alpha, \quad \alpha^2 = 1. \tag{B7-5}$$

$\hat{\varepsilon}_\alpha$ is the ε operator of the weight lattice of C_ℓ defined in Sect. B.6. $\tilde{\cdot}$ maps the short roots $1/\sqrt{2}(\pm\varepsilon_i \pm \varepsilon_j)$ of C_ℓ onto the $\tilde{\alpha} = 1/\sqrt{2}(\varepsilon_i - \varepsilon_j)$ of $A_+(A_{\ell-1})$. In a consistent way, we map the roots $1/\sqrt{2}\varepsilon_i$ of the \square representation of C_ℓ onto the weights $\tilde{\omega}_i = \frac{1}{\sqrt{2}}\left(\varepsilon_i - \frac{1}{\ell}\sum \varepsilon_i\right)$ of the \square of $A_{\ell-1}$. For these roots, the conformal weight of a current of the type (B7-5) would be $\varepsilon^2/2 + \tilde{\omega}^2/2 = 1/4 + \frac{\ell-1}{4\ell}$. We complete these currents by an additional Z vertex operator:

$$J(\alpha, z) = U_+(\alpha, z)U_-(\tilde{\alpha}, z) \circ \exp i \sqrt{\frac{2\ell+1}{2\ell}} Z_{(-)} \circ. \tag{B7-6}$$

The factor $\sqrt{(2\ell+1)/2\ell}$ restores the local character and also produces the necessary double pole in the O.P.E.

Once more, one can check the existence of a unique highest weight A_ℓ in the representation space:

$$\mathcal{H} = \text{Fock}(X^i, Y^j, Z) \otimes W(C_\ell), \tag{B7-7}$$

and evaluate the string function:

$$C(q) = q^{-2\ell/24 + \ell/16} \prod_{n>0} (1 - q^n)^{-\ell} (1 - q^{n-1/2})^{-\ell}. \tag{B7-7}$$

B.8. Two Constructions of $D_4^{(3)}$

$D_4^{(3)}$ admits two homogeneous gradations such that the horizontal algebra is either A_2 or G_2 (see Sect. A.1). We shall construct in each case the unique level one module.

The construction with A_2 horizontal is parafermionic, and generalizes the fermionic construction of the 2-twisted algebras. We use four Fubini-Veneziano fields without zero modes. We average over the orbits of an automorphism σ of order three of the root lattice of D_4 without fixed point. 3×3 matrices generalizing the familiar Dirac matrices provide the necessary sign factors.

The construction with G_2 horizontal generalizes the bosonic construction of the 2-twisted algebras. We start from the Frenkel-Kac representation of the long roots of G_2 . This involves two Fubini-Veneziano fields with their zero modes included and the usual cocycle (B2-6). Then, we complete the currents associated to the short roots by auxiliary fields which are, up to a rescaling, the Kac-Kazhdan-Lepowsky-Wilson currents of the principal construction of $A_2^{(1)}$ [16].

Let us first recall this last construction. Consider a pair of $3Z$ graded fields

$$\psi_\omega(z) = -i \sum_{n \in \mathbb{Z}} (1 - \omega^n) x_{-n} \frac{z^n}{n}, \tag{B8-1}$$

where the x_n operators satisfy the canonical commutation relations (A4-12a) and $\omega = \exp(\pm 2i\pi/3)$.

Now consider the inner automorphism $\sigma, \sigma^3 = e$, of the root lattice of A_2 which rotates the first simple root into the second. The six roots of A_2 split into two orbits with representatives α_1 and $(-\alpha_1)$. The affine Kac-Moody algebra $A_2^{(1)}$, twisted by

this inner automorphism, is represented on the Fock space

$$\mathcal{H} = \text{Fock}(x_n; n \not\equiv 0 \pmod{3}) \tag{B8-2}$$

by the currents,

$$h_\omega(z) = i\partial_z \psi_\omega(z), \tag{B8-3}$$

and by the vertex operators,

$$V_\omega(z) = z^{-1} \circ \exp i\psi_\omega(z) \circ. \tag{B8-4}$$

There is no need for a cocycle because the O.P.E. of the V_ω are symmetric.

$$V_\omega(z)V_\omega(w) = \frac{(z-w)^2}{(z-\omega w)(z-\bar{\omega}w)} \frac{1}{zw} \circ e^{i(\psi_\omega(z) + \psi_\omega(w))} \circ, \tag{B8-5a}$$

$$V_\omega(z)V_{\bar{\omega}}(w) = \frac{(z-w)(z-\omega w)}{(z-\bar{\omega}w)^2} \frac{1}{zw} \circ e^{i(\psi_\omega(z) + \psi_{\bar{\omega}}(w))} \circ. \tag{B8-5b}$$

The eight generators of $SU(3)$ are reorganized as follows: six generators are represented by the $(3Z + m)$, $m = 0, 1, 2$, modes of V_ω and $V_{\bar{\omega}}$; the two others, by the h_ω which only have modes in the class $(3Z \pm 1)$.

There is in this construction a single level one module for the following reason. As explained in Sect. A, the distinction between the various level one modules of an affine algebra is gradation dependent. The principal gradation of $A_2^{(1)}$ that we are considering is symmetric in the 3 simple roots of $A_2^{(1)}$. In the notations of Sect. A, we have:

$$\alpha_i(d) = 1/3, \quad i = 0, 1, 2.$$

The three level one modules are therefore isomorphic even as Virasoro-Kac-Moody modules. The partition function of \mathcal{H} is

$$\begin{aligned} \text{Tr}_{\mathcal{H}}(q^{\tau_0}) &= q^{\frac{2}{18} - \frac{2}{24}} \prod_{n>0} (1 - q^{n-1/3})(1 - q^{n-2/3}) \\ &= \eta(q)/\eta(q^{1/3}). \end{aligned} \tag{B8-6}$$

The bosonic construction of $D_4^{(3)}$ corresponds to the gradation in which the horizontal algebra is G_2 . The root system given in (A1-28a) follows from the decomposition of D_4 with respect to G_2 ,

$$D_4 = G_2 + \bar{1} + \bar{1}. \tag{B8-7}$$

As G_2 has short roots normed to $\alpha \cdot \alpha = 2/3$, the standard vertex operators must be completed by auxiliary fields. By analogy with the $D_{\ell+1}^{(2)}$ case in which the auxiliary fields introduced in Sect. B.6 are the rescaled fields of $A_1^{(1)}$ principal, we introduce the rescaled fields of $A_2^{(1)}$ principal (B8-4) as auxiliary fields for $D_4^{(3)}$.

Thus, let us introduce the tensor product of the Fock space generated by two Fubini-Veneziano fields, $X_{(3)}^i(z)$, $i = 1, 2$, containing only modes modulo [3], by the Fock space (B8-2),

$$\mathcal{H} = \text{Fock}(X_{(3)}^i, \psi) \otimes W(G_2). \tag{B8-8}$$

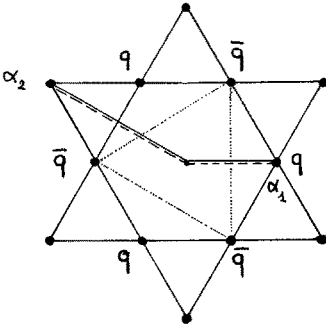

Fig. 5. Root diagram of G_2 (B8-9). α_0 and α_1 form a system of simple roots. The 6 short roots form the quark and antiquark representations of the long $SU(3)$ subalgebra

Note that $W(G_2)$, the weight lattice of G_2 , associated to the zero modes of the fields $X^i(z)$, coincides with the root lattice of G_2 .

Once more, we define the 2-cocycle, $\varepsilon(\alpha, \beta)$, on $A(G_2)$ by Eqs. (B2-6)–(B2-9). As $a_{ij}, i \neq j$, is always odd, we can choose any order in (B2-6). The long roots of G_2 generate an algebra A_2 . The short roots split into two representations of this A_2 : the quark and the antiquark as described in Fig. 5. By bimultiplicativity (B2-7), $\varepsilon(\alpha, \beta)$ is a two cocycle, and hence satisfies

$$\varepsilon(\alpha, \beta)\varepsilon(\beta, \alpha) = (-1)^{\alpha \cdot \beta - \frac{2}{3}t(\alpha)t(\beta)} = (-1)^{3\alpha \cdot \beta}, \tag{B8-9}$$

where $t(\alpha) = 0$ if α is a long root or $t(\alpha) = +1$ (-1) if α is in the (anti-)quark representation: t is the triality of $SU(3)$.

Let us now define the rescaled fields of $A_2^{(1)}$ principal,

$$W_\omega(z) = \circ \exp \left[\frac{\sqrt{2}}{3} \psi_\omega(z) \right] \circ, \tag{B8-10}$$

which satisfy the O.P.E. (B8-5) up to the power $(2/3)$.

The bosonic construction of $D_4^{(3)}$ is then given by the currents,

$$\begin{aligned} h^i(z) &= i\partial_z X^i(z), \quad i=1, 2, \\ h_\omega(z) &= i\partial_z \psi_\omega(z), \quad \omega = \exp(\pm 2i\pi/3), \\ J(\alpha, z) &= z^{3\alpha^2 - 1} \circ \exp i\alpha \cdot X_{(3)}(z) \circ W_\alpha(z) \hat{e}_\alpha, \\ \tilde{\alpha} &= \exp(2i\pi t(\alpha)/3). \end{aligned} \tag{B8-11}$$

The modes,

$$h_n^i = \oint \frac{dz}{2\pi i} z^{n-1} P^i(z), \tag{B8-12}$$

$$J_n^\alpha = \oint \frac{dz}{2i\pi} J(\alpha, z), \quad t(\alpha) = 0$$

appear only for $n \equiv 0$ [3], and represent $A_2^{(1)}$ of level one. The modes

$$J_n^\alpha = \oint \frac{dz}{2i\pi} J(\alpha, z), \quad t(\alpha) \neq 0 \tag{B8-13}$$

complete the $A_2^{(1)}$ representation to $D_4^{(3)}$. All the $n \equiv 0$ [3] modes represent the $G_2^{(1)}$ subalgebra of level one.

The Hilbert space \mathcal{H} is irreducible and contains the unique level one module of $D_4^{(3)}$. The highest weight is a scalar of the horizontal algebra G_2 . The string function of $D_4^{(3)}$ of level one reads,

$$C(q) = q^{2/18 - 4/24} \prod_{n>0} (1 - q^n)^2 (1 - q^{n-1/3}) (1 - q^{n-2/3}). \tag{B8-14}$$

The fermionic construction corresponds to the gradation having A_2 as horizontal algebra. It is defined by an outer automorphism σ of D_4 of order three without fixed point. σ is completely defined, up to a Weyl transformation, by imposing,

$$\alpha + \sigma\alpha + \sigma^2\alpha = 0 \tag{B8-15}$$

for every root α of D_4 . The σ -invariant algebra is A_2 .

By analogy with the construction B.5, which corresponds to the automorphism $\sigma = -1$, we introduce four Fubini-Veneziano fields $X^i(z)$ (A4-14a), and their associated σ -fields, $\chi_\sigma^i(z)$ and $\chi_{\sigma^2}^i(z)$, defined by

$$\begin{aligned} \alpha \cdot \chi_\sigma(z) &= \sum_{p=0}^2 (\sigma^p \alpha) \cdot X(\omega^p z), \\ \alpha \cdot \chi_{\sigma^2}(z) &= \sum_{p=0}^2 (\sigma^p \alpha) \cdot X(\bar{\omega}^p z). \end{aligned} \tag{B8-16}$$

The fields χ_σ and χ_{σ^2} commute,

$$[\chi_\sigma(z), \chi_{\sigma^2}(z)] = 0 \tag{B8-17}$$

and only contain modes $n \equiv \pm 1$ [3] [due to (B8-15)]. For the automorphism $\sigma = -1$, χ_σ reduces to the odd graded field introduced in B.5. The σ -vertex operators

$$U_\sigma(\alpha, z) = \frac{1}{\sqrt{3}} \circ \exp\left(\frac{i}{\sqrt{3}} \alpha \cdot \chi_\sigma(z)\right) \circ = U_\sigma(\sigma\alpha, \omega z) \tag{B8-18}$$

satisfy the O.P.E.

$$U_\sigma(\alpha, z) U_\sigma(\beta, w) = \prod_{p=0}^2 (z - \omega^p w)^{\sigma^p \alpha \cdot \beta} \circ U_\sigma(\alpha, z) U_\sigma(\beta, w) \circ. \tag{B8-19}$$

The fermionic construction is defined on the space

$$\mathcal{H} = \text{Fock}(\chi_\sigma) \otimes V \tag{B8-20}$$

tensor product of the Fock space of the fields χ_σ by a three dimensional vector space V . On the space V , we introduce a set of 3×3 matrices, E_α where α is a root of D_4 , satisfying

$$E_\alpha E_\beta = \varepsilon(\alpha, \beta) E_{\alpha + \beta}, \tag{B8-21}$$

with

$$\varepsilon(\beta, \alpha) \varepsilon^{-1}(\alpha, \beta) = \prod_{p=0}^2 (\omega^p)^{\alpha \cdot \sigma^p \beta}. \tag{B8-22}$$

They can be defined by,

$$E_\alpha = \prod_i (E_{\alpha_i})^{n_i} \quad \text{if } \alpha = \sum n_i \alpha_i \tag{B8-23}$$

from the matrices associated to the simple roots α_i of D_4 . Namely,

$$E_{\alpha_1} = \begin{bmatrix} 0 & 1 & 0 \\ 0 & 0 & 1 \\ 1 & 0 & 0 \end{bmatrix}, \quad E_{\alpha_2} = E_{\alpha_3} = \begin{bmatrix} 1 & 0 & 0 \\ 0 & \omega & 0 \\ 0 & 0 & \bar{\omega} \end{bmatrix}, \quad E_{\alpha_4} = \begin{bmatrix} 0 & \bar{\omega} & 0 \\ 0 & 0 & \omega \\ 1 & 0 & 0 \end{bmatrix} \tag{B8-24}$$

Now, the currents,

$$h_\sigma^i(z) = i\partial_z \chi_\sigma^i(z), \tag{B8-25a}$$

$$J_\sigma(\alpha, z) z^{-1} U_\sigma(\alpha, z) E_\alpha, \tag{B8-25b}$$

represent $D_4^{(3)}$ in the fermionic gradation. The modes,

$$h_{\sigma n}^i = \oint \frac{dz}{2i\pi} z^n h_\sigma^i(z) \tag{B8-26}$$

appear only for $n \equiv \pm 1$ [3], whereas the fields $J_\sigma(\alpha, z)$ contain all the integral modes,

$$J_\alpha^n = (J_{-\alpha}^{-n})^+ = \oint \frac{dz}{2i\pi} z^n J_\sigma(\alpha, z). \tag{B8-27}$$

The modes $n \equiv 0$ [3] represent $A_2^{(1)}$ of level three.

The Hilbert space is irreducible and contains the unique level one module of $D_4^{(3)}$: the space V identifies with the representation 3 of A_2 . The q -dimension of the representation is:

$$C(q) = 3q^{4/18 - 4/24} \prod_{n>0} (1 - q^{n-1/3})^2 (1 - q^{n-2/3})^2 = 3\eta(q)^2 \eta(q^{1/3})^{-2}. \tag{B8-28}$$

At last, the definition of the σ -vertex operator can be extended to an arbitrary automorphism σ of a simply laced algebra. This fermionic construction of $D_4^{(3)}$ is implicit in the work of Kac and Peterson [25]; the bosonic construction is completely new.

C. Interacting Field Constructions

The algebras $C_n^{(1)}$, $F_4^{(1)}$, and $G_2^{(1)}$ in their unique homogeneous gradation are the integrally graded subalgebras of $A_{2n-1}^{(2)}$, $E_6^{(2)}$, $D_4^{(3)}$. As such, their construction is implicit in Sect. B. However to disentangle the integrally from the non-integrally graded short roots we need to modify our construction quite drastically.

*) We construct, in Sect. C.1, an auxiliary Virasoro algebra with a fractional central charge (Table 8) and its primary fields (Sect. C.1).

***) We use these primary fields as auxiliary currents to construct $G_2^{(1)}$ and $A_2^{(2)}$ in Sect. C.3 and $C_n^{(1)}$ and $F_4^{(1)}$ in Sect. C.5.

Table 8. Decomposition of the central charge c of the Virasoro algebra of the level k module of $g^{(1)}$:

$$c = \text{rank}(g) + c_{\text{aux}}.$$

g_{aux} is the auxiliary Lie algebra used to construct an interacting stress tensor of type (1) or (2) with central charge c_{aux} (C1-3)

g	k	c	g_{aux}	$c_{(1)}$	$c_{(2)}$
A_1	N	$1 + 2(N-1)/(N+2)$	A_{n-1}	$2(N-1)/(N+2)$	
$g_p \begin{cases} A_p \\ D_p \\ E_p \\ B_p \\ C_p \\ F_4 \\ G_2 \end{cases}$	2	$p + hp/(h+2)$	g_p		$hp/(h+2)$
	1	$p + 1/2$	A_1	$1/2$	
	1	$p + p(p-1)/(p+2)$	A_{p-1}		$p(p-1)/(p+2)$
	1	$4 + 6/5$	A_2		$6/5$
	1	$2 + 4/5$	A_2	$4/5$	

***) As a side step, we need the level three and four representations of $A_1^{(1)}$, which are contained in $G_2^{(1)}$ and $A_2^{(2)}$ of level one, and the level two representations of $A_{n-1}^{(1)}$ which are contained in $C_n^{(1)}$ of level one. We actually solve a slightly more general problem: we construct the representations of $A_1^{(1)}$ of arbitrary level in Sect. C.2, and the representations of level 2 of A, D, E in Sect. C.4.

C.1. Construction of the Auxiliary Virasoro Algebras

As explained in Sect. B, the currents which generate the Kac-Moody algebras are constructed by completing the Frenkel-Kac vertex operators, corresponding to the Cartan subalgebra, with some auxiliary fields. These auxiliary fields must be primary fields with respect to the auxiliary Virasoro algebra, $L(g) - L(h)$, where h is the Cartan subalgebra of g . The central charges are given in Table 8. When the central charge is not a half integer, the Virasoro algebra cannot be represented by a free field stress-tensor. But, by completing the work of Eguchi and Higashijima [26], one can define the following stress-tensor:

$$\tilde{T}(z) = 2a \sum_{\tilde{\alpha} \in A} \circ(i\tilde{\alpha}\partial_z \tilde{X})^2 \circ + b \sum_{\tilde{\alpha} \in A} \circ e^{2i\tilde{\alpha} \cdot \tilde{X}} \circ. \tag{C1-1}$$

Here, $\tilde{\alpha}$ is a root of an A, D, E Lie algebra of rank p . $\tilde{\alpha}$ is normed to $\tilde{\alpha} \cdot \tilde{\alpha} = 1$. The fields $\tilde{X}^i(z)$ are p Z -graded Fubini-Veneziano fields (A4-11). $\tilde{T}(z)$ operates on the space Fock(\tilde{X}) * W , Eq. (A4-13). After a lengthy calculation, using extensively the relation [43]:

$$\sum_{\tilde{\alpha} \in A} \frac{(\tilde{\beta}, \tilde{\alpha})(\tilde{\alpha}, \tilde{\gamma})}{(\tilde{\alpha}, \tilde{\alpha})} = h(\tilde{\beta}, \tilde{\gamma})$$

(where h is the Coxeter number) one can show that $T(z)$ generates a Virasoro algebra if the coefficients a and b are:

$$\begin{aligned} a_{(0)} &= 1/4h, & b_{(0)} &= 0, \\ a_{(1)} &= 1/2h(h+2), & b_{(1)} &= 1/(h+2), \\ a_{(2)} &= 1/4(h+2), & b_{(2)} &= -1/(h+2). \end{aligned} \tag{C1-2}$$

The central charge of the three Virasoro algebras $L_{(0)}$, $L_{(1)}$, and $L_{(2)}$ are (Table 8):

$$c_{(0)}=p, \quad c_{(1)}=\frac{2p}{h+2}, \quad c_{(2)}=\frac{hp}{h+2}. \tag{C1-3}$$

$L_{(0)}$ is the Virasoro of the p free bosons (A4-17) and is also the sum of the two others,

$$L_{(0)}=L_{(1)}+L_{(2)}. \tag{C1-4a}$$

Furthermore, the generators $L_{(1)}$ and $L_{(2)}$ commute,

$$[L_{(1)}, L_{(2)}]=0. \tag{C1-4b}$$

The central charges $c_{(1)}$ for the Lie algebras $SU(N)$ correspond to the auxiliary central charges of the level N representation of $su(2)$ affine. They also correspond to the auxiliary central charges of the basic representations of $B_\ell^{(1)}$ and $G_2^{(1)}$ which contain representations of level 2 and 3 of $A_1^{(1)}$. It should be noted that for the algebras E_ℓ , A_2 , A_3 , the central charges $c_{(1)}$ are less than one. As expected, they belong to the unitary series $c=1-6/m(m+1)$. Their value are $c_{(1)}=6/7$, $7/10$, and $1/2$ for E_6 , E_7 , and E_8 respectively. The central charges $c_{(2)}$ are the auxiliary central charges of the level two representations of the $A^{(1)}$, $D^{(1)}$, $E^{(1)}$, and also of the basic representations of $F_4^{(1)}$ and $C_\ell^{(1)}$.

We shall now construct primary fields of these Virasoro algebras which may be used as auxiliary fields in the current algebras. For the $L_{(1)}$ algebras, primary fields can be constructed by means of vertex operators defined on the basic representations of the Lie algebras A, D, E . Namely, let us define the fields $\Gamma(z)$ as:

$$\Gamma_R(z)=\frac{1}{\sqrt{\dim(R)}} \sum_{\tilde{\omega} \in R} \circ e^{2i\tilde{\omega} \cdot \tilde{X}(z)} \circ, \tag{C1-5}$$

where the weights $\tilde{\omega}$ belong to a minuscule representation, noted R , of A, D, E Lie algebras. It is a primary field for both $L_{(0)}$ and $L_{(1)}$ with the same conformal weight Δ :

$$\Delta_{(0)}=\Delta_{(1)}=2\tilde{\omega}^2. \tag{C1-6}$$

In particular, for the vectorial representation of $su(N)$, noted \square , and for its complex conjugate $\bar{\square}$, the conformal weights are:

$$\Delta_{\square}=\Delta_{\bar{\square}}=\frac{N-1}{N}. \tag{C1-7}$$

Furthermore, by using the relation (C1-3) and the fact that the conformal weights with respect to $L_{(0)}$ and $L_{(1)}$ are equal, one deduces that the fields $\Gamma(z)$ commute with the third Virasoro algebra $L_{(2)}$. That property will be very useful in the study of the various Kac-Moody representations constructed below.

In the case of $su(2)$, the $\Gamma(z)$ fields reduce simply to fermionic fields (A4-28):

$$\Gamma(z)=\frac{1}{\sqrt{2}}[e^{i\tilde{X}}+e^{-i\tilde{X}}]. \tag{C1-8}$$

$\Gamma(z)$ is a N.-S. or R. field according to the lattice class to which the momentum belongs.

Primary fields of the $L_{(2)}$ algebras can be defined by:

$$\psi(\alpha, z) = \frac{i}{\sqrt{2}} [e^{i\tilde{\alpha} \cdot \tilde{X}} - e^{-i\tilde{\alpha} \cdot X}]. \tag{C1-9}$$

They are also primary fields of the $L_{(0)}$ algebras. Their conformal weights are equal to

$$A_{(0)} = A_{(2)} = \frac{\tilde{\alpha}^2}{2} = \frac{1}{2}, \tag{C1-10}$$

reflecting their fermionic character. As before, they commute with the last Virasoro algebra $L_{(1)}$.

C.2. Representations of $A_1^{(1)}$ of Arbitrary Level

The currents of the level N representations of $A_1^{(1)}$ will be written as the product of the Frenkel-Kac currents by some auxiliary fields that we shall now determine. In keeping with Weyl group properties (A3-11), the square of the root appearing in the Frenkel-Kac vertex operator must be normalized to $2/N$. Furthermore, as $su(2)$ is of rank one, it is sufficient to introduce only one auxiliary field and its complex conjugate. In order that the currents be primary fields of the total Virasoro algebra, $L^T = L_{\text{free}}(X) + L_{(1)}(A_{N-1})$, with a conformal weight equal to one, the auxiliary field must be a primary field of the $L_{(1)}$ algebra with $(N-1)/N$ as conformal weight. At the same time, the O.P.E. of the currents, product of the standard vertex operators by the auxiliary fields, are single valued if the auxiliary fields are primary fields for the $L_{(0)}$ algebra with the same conformal weight, $(N-1)/N$. Therefore, the fields $\Gamma_{\square}(z)$ and $\Gamma_{\bar{\square}}(z)$ [(C1-5) and (C1-7)] are respectable auxiliary field candidates. Their O.P.E. are inferred from the decomposition of the tensorial product of the $su(N)$ representation; $\square * \bar{\square} = \text{Adj} + 1$, and $\square * \square = \square\square + \bar{\square}$. They read:

$$\begin{aligned} \Gamma_{\square}(z)\Gamma_{\bar{\square}}(w) &= \frac{1}{N}(z-w)^{2/N-2} \\ &\times \left[\sum_{\tilde{\omega} \in \square} \circ e^{2i\tilde{\omega} \cdot (\tilde{X}(z) - \tilde{X}(w))} \circ + (z-w)^2 \sum_{\tilde{\omega} + \tilde{\omega}' \in \text{Adj}} \circ e^{i(\tilde{\omega} \cdot X(z) + \tilde{\omega}' \cdot \tilde{X}(w))} \circ \right], \\ \Gamma_{\bar{\square}}(z)\Gamma_{\square}(w) &= \frac{1}{N}(z-w)^{2-2/N} \\ &\times \left[\sum_{\tilde{\omega} \in \bar{\square}} \circ e^{2i\tilde{\omega} \cdot (\tilde{X}(z) + \tilde{X}(w))} \circ + (z-w)^{-2} \sum_{\tilde{\omega} \neq \tilde{\omega}'} \circ e^{i\tilde{\omega} \cdot \tilde{X}(z) + i\tilde{\omega}' \cdot \tilde{X}(w)} \circ \right]. \end{aligned} \tag{C2-1}$$

The level N representation of $A_1^{(1)}$ is defined as follows. Let $(\pm\alpha)$ denote the roots of A_1 rescaled to $\alpha \cdot \alpha = 2/N$, and $W(A_1)$ the associated weight lattice. Let $\tilde{W}(A_{N-1})$ denote the weight lattice of A_{N-1} , the roots of A_{N-1} being normed to $\tilde{\alpha} \cdot \tilde{\alpha} = 1$. Define also the bosonic fields, $X(z)$ and $\tilde{X}^i(z)$, $i=1$ to $(N-1)$, (A4-11), respectively associated to A_1 and $\tilde{A}_{N-1} \cdot A_1^{(1)}$ is represented on the Hilbert space,

$$\mathcal{H} = \text{Fock}(X, \tilde{X}^i) \otimes W(A_1) \otimes \tilde{W}(A_{N-1}). \tag{C2-2}$$

The currents associated to the real roots are

$$J(\alpha, z) = \Gamma_{\square}(z) \circ \exp i\alpha \cdot X(z) \circ, \tag{C2-3a}$$

$$J(-\alpha, z) = |z|^{-2} J\left(\alpha, \frac{1}{z}\right)^+ = \Gamma_{\square}(z) \circ \exp -i\alpha X(z) \circ, \tag{C2-3b}$$

whereas the imaginary roots are represented by the currents,

$$h_x(z) = iN\alpha \cdot \partial_z X(z). \tag{C2-4}$$

The commutation relations directly follow from the O.P.E. (A4-25) and (C2-1). $W(A_1)$ decomposes into two cosets: the tensor and the spinor weights. $W(A_{N-1})$ decomposes into N cosets which correspond to the N fundamental representations R_j of A_{N-1} ,

$$\tilde{W}(A_{N-1}) = \bigcup_{j=0}^{N-1} (\lambda_j + A(A_{N-1})), \tag{C2-5}$$

where λ_j is the highest weight of the R_j representation of A_{N-1} . The currents will be single valued if the momentum p of X and \tilde{p} of \tilde{X} satisfy

$$(2\tilde{\alpha}\tilde{p} + \alpha p) \in \mathbb{Z}. \tag{C2-6}$$

The absence of fractional power of $(z-w)$ in the O.P.E. of the currents reveals that these constraints commute with the currents.

As the $L_{(2)}$ algebra commutes with the currents (C2-3), these representations are infinitely degenerate. But, by looking at the representations of the product $L_{(2)} * A_1^{(1)}$, one reduces the degeneracy to a finite order. In particular, the highest weight vector of the $(n \circlearrowleft N-n) * L_{(2)}$ representation, $A = nA_1 + (N-n)A_0$, is the vacuum vector whose momentum p is the highest weight of the n^{th} representation of $su(2)$ and whose momentum \tilde{p} is a weight of the n^{th} representation of $su(N)$. The infinite set of highest weight vectors of $A_1^{(1)}$ is then generated by applying the $L_{(2)}$ generators to these vectors, i.e.: they belong to the $L_{(2)}$ -Verma module built upon these vectors.

In the case of $N \leq 3$, we can say more about the structure of the representations. Each string is a reducible representation of the total Virasoro algebra, $L^T = L_{\text{free}}(X) + L_{(1)}$. Let us define the quotients of the strings by the L_{free} -Verma module. On these spaces, the Virasoro algebra L^T identifies with the $L_{(1)}$ algebra. These quotient spaces are unitary representations of $L_{(1)}$. The string functions can thus be written as:

$$C_A^\mu(q) = \eta^{-1}(q) chL_{(1)}(q), \tag{C2-7}$$

where $chL_{(1)}$ are the character of the $L_{(1)}$ Virasoro algebra in the quotient spaces. In general, these quotient spaces can also be highly reducible. But in the $N \leq 3$ case, the auxiliary central charge is less than one, and hence the degeneracy is finite. If $A_{(1)}$ is the conformal weight, with respect to $L_{(1)}$, of the highest vector of the string, the conformal weight of the vectors of the quotient space are $(A_{(1)} + k)$, $k \in \mathbb{N}$. A new highest weight vector of $L_{(1)}$ occurs in the quotient space only if $(A_{(1)} + k)$ belongs to the set of unitary conformal weights (A2-21).

In the $N=2$ case, the central charge is one half. The unitary weights are 0, $1/2$, and $1/16$. Therefore the quotient spaces are irreducible, and the string functions read:

$$\begin{aligned} C_{20}^{20}(q) &= \eta^{-1}(q)chL_{(1)}(c=1/2, \Delta=0)(q), \\ C_{02}^{20}(q) &= \eta^{-1}(q)chL_{(1)}(c=1/2, \Delta=1/2)(q), \\ C_{11}^{11}(q) &= \eta^{-1}(q)chL_{(1)}(c=1/2, \Delta=1/16)(q), \end{aligned} \tag{C2-8}$$

where $C_{k\ell}^{ij}(q) = C^{iA_0 + jA_1}_{kA_0 + \ell A_1}(q)$.

The conformal weights $\Delta_{(1)}$ which occur in the $N=3$ case are for the $(1 \circlearrowleft \circlearrowright 0)$ representation, $\Delta_{(1)} = 1/15$ and $2/5$, and for the $(3 \circlearrowleft \circlearrowright 0)$ representation, $\Delta_{(1)} = 0$ and $2/3$. But the conformal weights $7/5$ and 3 are also unitary weights for $c=4/5$. Therefore, the quotient spaces in the strings having $\Delta_{(1)} = 0$ or $2/5$ can be reducible. The degeneracy in these strings can be evaluated by means of the Racah recursion (see Sect. A.3 and Fig. 3), and the representations with conformal weight 3 or $7/5$ do occur. Thus, the various string functions read:

$$\begin{aligned} C_{30}^{30}(q) &= \eta^{-1}(q)[ch(4/5, 0) + ch(4/5, 3)](q), \\ C_{30}^{12}(q) &= \eta^{-1}(q)ch(4/5, 2/3)(q), \\ C_{12}^{12}(q) &= \eta^{-1}(q)ch(4/5, 1/15)(q), \\ C_{12}^{30}(q) &= \eta^{-1}(q)[ch(4/5, 2/5) + ch(4/5, 7/5)](q). \end{aligned} \tag{C2-9}$$

It is quite puzzling to note that these combinations of the Virasoro characters coincide with those appearing in the 3-state Potts model [44].

This method of evaluation of the string functions of the representations of $A_1^{(1)}$ cannot be pursued for higher level. However, all the string functions of $A_1^{(1)}$ were evaluated in [45], from their modular properties.

C.3. $K=1$ Representations of $B_\ell^{(1)}$, $G_2^{(1)}$, and $A_2^{(2)}$

As the representations of $A^{(1)}$, $D^{(1)}$, $E^{(1)}$ follow from the representation of $A_1^{(1)}[k=1]$, the representations of $B_\ell^{(1)}$, $G_2^{(1)}$, and $A_2^{(2)}$ follow from the representations of $A_1^{(1)}$ with $k=2, 3$, and 4 respectively.

In the construction of $B_\ell^{(1)}$ given in Sect. B.3, the vertex operator associated to a short root is completed by an auxiliary free fermion $\Gamma(z)$. This field is equivalent to the $\Gamma_\square(z)$ of $SU(2)$ (C1-8), needed in the construction of $A_1^{(1)}[k=2]$. The string functions are trivially related, compare (B3-6) and (C2-8).

The root system of the G_2 algebra is described in Fig. 5. As the ratio of the square of the long roots by the square of the short ones is equal to three, the basic representation contains a level three representation of $su(2)$ affine (see Sect. D). On the other hand, the short roots belong to the \square and $\bar{\square}$ representations of the $su(3)$ regular subalgebra generated by the long roots. Therefore, the currents are naturally defined on the space,

$$\mathcal{H} = \text{Fock}(X^i, \tilde{X}^k) \otimes W(G_2) \otimes \tilde{W}(A_2), \tag{C3-1}$$

where $X^i(z)$, $i=1$ to 2 , are the Fubini-Veneziano fields associated to G_2 , and $\tilde{X}^k(z)$, $k=1$ to 2 are the auxiliary bosonic fields introduced in Sect. C.1 in the particular

case of $SU(3)$. The real roots currents are

$$J(\alpha, z) = \begin{cases} \circ \exp i\alpha \cdot X(z) \circ \hat{\varepsilon}_\alpha, & t(\alpha) = 0, \quad \alpha^2 = 2, & (C3-2a) \\ \Gamma_{\square}(z) \circ \exp i\alpha \cdot X(z) \circ \hat{\varepsilon}_\alpha, & t(\alpha) = 1, & (C3-2b) \\ \Gamma_{\square}(z) \circ \exp i\alpha \cdot X(z) \circ \hat{\varepsilon}_\alpha, & t(\alpha) = 2, & (C3-2c) \end{cases}$$

where $t(\alpha)$ and ε_α are the triality and the cocycle operators defined in Eqs. (B2-6) to (B2-9) and (B8-9) and the $\Gamma_{\square}(z)$ fields are defined in (C1-5). The imaginary roots are represented, once more, by the fields $i\partial_z X^i(z)$. From Eq. (C2-1), particularized to the $N=3$ case, it is easy to verify that these operators have the correct O.P.E. in order to represent the $G_2^{(1)}$ affine algebra.

The structure of the representation follows from the structure of the level three representations of $A_1^{(1)}$. First, the $L_{(2)}$ Virasoro generators commute with the currents (C3-2). Second, the auxiliary central charge is less than one. Therefore, the string functions of the 2 level one modules are:

$$\begin{aligned} C_{A_2}^{A_2}(q) &= C_{A_0}^{A_0}(q) = \eta^{-1}(q) C_{30}^{30}(A_1^{(1)})(q), \\ C_{A_2}^{A_0}(q) &= C_{A_0}^{A_2}(q) = \eta^{-1}(q) C_{30}^{12}(A_1^{(1)})(q). \end{aligned} \tag{C3-3}$$

The last algebra in which these auxiliary fields can be used, is the twisted affine algebra $A_2^{(2)}$. In Sect. B.4, a fermionic construction of this algebra was given in terms of odd fields. It was based on an automorphism of order two of A_2 yielding the Z_2 gradation:

$$A_2 = A_1 + \zeta. \tag{C3-4}$$

The root system given in Fig. 2 follows from that decomposition.

We now present a bosonic version of that construction. The construction is defined on the space

$$\mathcal{H} = \text{Fock}(X, \tilde{X}^k) \otimes (\square + \mathcal{A}(A_1)) \otimes (\square + \mathcal{A}(A_3)), \tag{C3-5}$$

where $X(z)$ is the Fubini-Veneziano field associated to the horizontal algebra A_1 , and the $\tilde{X}^k(z)$, $k=1$ to 3 are the bosonic fields associated to the auxiliary algebra $SU(4)$. $(\square + \mathcal{A}(A_p))$ is the coset of the weight lattice of A_p containing the fundamental representation.

The ratio of the square length of the simple roots is equal to four. The auxiliary fields, that must be introduced in front of the vertex operators of the short roots, are built upon an $su(4)$ algebra. We define the fields $\Gamma_{\square}(z)$ and $\Gamma_{\square}(z)$ by Eq. (C1-5). We define also the hermitic field $\Gamma_{\square}(z)$ constructed over the 6-representation of $su(4)$ by the same equation. The O.P.E. given in Eq. (C2-2) and the following ones:

$$\begin{aligned} \Gamma_{\square}(z)\Gamma_{\square}(w) &= \frac{1}{\sqrt{24}} \frac{1}{z-w} \\ &\times \left[\sum_{\tilde{w} + \tilde{w}' \in \square} \circ e^{2i(\tilde{w}\tilde{X}(z) + \tilde{w}' \cdot \tilde{X}(w)) \circ} + (z-w)^2 \sum_{\tilde{w} \cdot \tilde{w}' > 0} \circ e^{2i(\tilde{w} \cdot \tilde{X}_z + \tilde{w}' \cdot \tilde{X}_w) \circ} \right], \\ \Gamma_{\square}(z)\Gamma_{\square}(w) &= \frac{1}{6} \frac{1}{(z-w)^2} \\ &\times \left[\sum_{\tilde{w} \in \square} \circ e^{2i\tilde{w}(\tilde{X}_z - \tilde{X}_w) \circ} + (z-w)^2 \sum_{\tilde{w} \cdot \tilde{w}' \geq 0} \circ e^{2i(\tilde{w} \cdot \tilde{X}_z + \tilde{w}' \cdot \tilde{X}_w) \circ} \right], \end{aligned} \tag{C3-6}$$

show that the twisted $A_2^{(2)}$ algebra can be represented as follows. We normalize the roots α of A_1 to $\alpha \cdot \alpha = 1/2$. We consider the currents:

$$\circ e^{-2i\alpha \cdot X \circ}, \quad \Gamma_{\square} \circ e^{-i\alpha \cdot X \circ}, \quad \Gamma_{\square}, \quad \Gamma_{\square} \circ e^{i\alpha X \circ}, \quad \circ e^{2i\alpha X \circ}, \quad (C3-7a)$$

$$\Gamma_{\square} \circ e^{-i\alpha X \circ}, \quad i\partial_z X, \quad \Gamma_{\square} \circ e^{i\alpha X \circ}, \quad (C3-7b)$$

which are distributed in keeping with the root diagram of $A_2^{(2)}$, Fig. 2. The currents are primary fields for the Virasoro algebra $L^T = L_{\text{free}}(X) + L_{(1)}$. Its central charge is two in agreement with (A2-7).

When (p, \tilde{p}) belong to the (\square, \square) coset of the weight lattice of $A_1 \otimes A_3$, i.e. $p \in (Z + 1/2)\alpha$ and $\tilde{p} \in (\square + A(A_3))$, the currents (C3-7a) only have $(Z + 1/2)$ modes, the currents (C3-7b) only Z modes, the operators have no cuts and close by commutation. This restriction on p agrees with the Dynkin diagram where we can read that the highest weight of the basic module of $A_2^{(2)}$ must be a spinor of the horizontal A_1 algebra.

The string function cannot be evaluated from this construction because the central charge of the auxiliary Virasoro algebra is one. However, we already know from (B7-5) that $c(q) = \eta(\sqrt{q})^{-1}$.

C.4. $K=2$ Representations of $A_\ell^{(1)}$, $D_\ell^{(1)}$, and $E_\ell^{(1)}$

We shall construct in this section the level two representations of the affine A, D, E algebras, and then use them to construct the basic representations of $F_4^{(1)}$ and $C_n^{(1)}$. The $L_{(2)}$ Virasoro algebras defined by Eqs. (C1-1) and (C1-2) have the central charge expected for the auxiliary Virasoro algebras of the level two representations of the simply laced algebras (Table 8). At the same time, in keeping with the analysis of the Weyl group (Sect. A), we wish to normalize the real roots to $\alpha \cdot \alpha = 2/k = 1$. Therefore, the Frenkel-Kac vertex operators have conformal weight one half with respect to L_{free} and we need auxiliary fields with conformal weight one half with respect to $L_{(2)}$. Hence, the fields $\Psi(\alpha, z)$ defined in Eq. (C1-9) are reasonable candidates. But, the O.P.E. of the currents will be of defined parity – which is absolutely necessary in order to reduce the computation of the commutation relations to the evaluations of the poles of the O.P.E., see the discussion following (A4-4) – if some sign factors are incorporated in the definition of the auxiliary fields. Consider the auxiliary space, Fock $(X) * \tilde{W}$ (A4-13), where \tilde{W} is a second copy of the weight lattice of A, D, E . And let us define the fields $\Psi(\alpha, z)$ as:

$$\psi(\tilde{\alpha}, z) = \frac{1}{2} [e^{i\tilde{\alpha} \cdot X} + e^{-i\tilde{\alpha} \cdot X} \zeta_{\tilde{\alpha}}(-1)^{2\tilde{\alpha} \cdot \tilde{p}}], \quad (C4-1)$$

where $\tilde{\alpha}$ is a root of A, D, E and is normed to $\tilde{\alpha} \cdot \tilde{\alpha} = 1$. $\zeta_{\tilde{\alpha}} \in \{+1, -1\}$ is defined on $A/2A$ by the recursion:

$$\zeta_{\tilde{\alpha} + \tilde{\beta}} = \zeta_{\tilde{\alpha}} \zeta_{\tilde{\beta}} (-1)^{2\tilde{\alpha} \cdot \tilde{\beta}}. \quad (C4-2)$$

The fields $\Psi(\alpha, z)$ define a set of non-independent fermionic fields. Their O.P.E. read:

$$\begin{aligned} \psi(\tilde{\alpha}, z)\psi(\tilde{\beta}, w) &= \frac{1}{4}(z-w)^{\tilde{\alpha} \cdot \tilde{\beta}} \\ &\times [\circ e^{i\tilde{\alpha} \cdot \tilde{X}(z) + i\tilde{\beta} \cdot \tilde{X}(w)} \circ + \circ e^{-i\tilde{\alpha} \cdot \tilde{X}(z) - i\tilde{\beta} \cdot \tilde{X}(w)} \circ \zeta_{\tilde{\alpha} + \tilde{\beta}}(-1)^{2(\tilde{\alpha} + \tilde{\beta}) \cdot \tilde{p}}] \\ &+ \frac{1}{4}(z-w)^{-\tilde{\alpha} \cdot \tilde{\beta}} \\ &\times [\circ e^{i\tilde{\alpha} \cdot \tilde{X}(z) - i\tilde{\beta} \cdot \tilde{X}(w)} \circ \zeta_{\tilde{\beta}}(-1)^{2\tilde{\beta} \cdot \tilde{p}} + \circ e^{-i\tilde{\alpha} \cdot \tilde{X}(z) + i\tilde{\beta} \cdot \tilde{X}(w)} \circ \zeta_{\tilde{\alpha}}(-1)^{2\tilde{\alpha}(\tilde{p} + \tilde{\beta})}]. \end{aligned} \quad (C4-3)$$

The Virasoro generators for which the fields $\Psi(\tilde{\alpha}, z)$ are primary fields are those defined in Eq. (C1-1) up to simple sign factor modifications:

$$\tilde{T}(z) = a \sum_{\tilde{\alpha}} \circ 2(i\tilde{\alpha} \partial_z \tilde{X})^2 \circ + b \sum_{\tilde{\alpha}} \circ e^{2i\tilde{\alpha} \cdot \tilde{X}} \circ \xi_{\tilde{\alpha}}(-1)^{1+2\tilde{\alpha} \cdot \tilde{p}}. \tag{C4-4}$$

The coefficients a and b are the same as those previously defined (C1-2), and they also correspond to the same central charges (C1-3).

Let us now consider the space,

$$\mathcal{H} = \text{Fock}(X^i, \tilde{X}^k) \otimes W(g) \otimes \tilde{W}(g),$$

where g is of type A, D, E . This space is just the square of the Hilbert space of the level one module (Sect. B.2).

To each positive root α of A we associate the same root α in \tilde{A} , and we consider the real root currents:

$$J(\alpha, z) = \psi(\tilde{\alpha}, z) \circ e^{i\alpha \cdot X(z)} \circ \hat{e}_{\alpha}. \tag{C4-5}$$

\hat{e}_{α} is the cocycle of Sect. B.2 [Eqs. (B2-6) to (B2-9)]. As usual, the Cartan currents are the fields $[i\alpha \cdot \partial_z X(z)]$. The commutation relations follow from the O.P.E. (A4-25) and (C4-3). Thanks to the factor $\xi_{\tilde{\alpha}}(-1)^{2\tilde{\alpha} \cdot \tilde{p}}$, they are effectively of defined parity. The currents are single valued if the momenta p and \tilde{p} satisfy the constraint:

$$(\alpha p \pm \tilde{\alpha} \tilde{p}) \in \mathbb{Z}. \tag{C4-6}$$

We shall now detail the reducibility of these representations. The currents $J(\alpha, z)$ are primary fields of the $L_{\text{free}}(X) + \tilde{L}_{(0)}$ and $L_{\text{free}} + \tilde{L}_{(2)}$ Virasoro algebras. They commute with the $\tilde{L}_{(1)}$ Virasoro algebra, which can be identified with the algebra $K = L(g^{(1)}[k=1] * g^{(1)}[k=1]) - L(g^{(1)}[k=2])$ in the Goddard, Kent, and Olive construction (A2-24). As $L_{(1)}$ commutes with the currents $J(\alpha, z)$ we can study the reducibility of the representation of $\tilde{L}_{(1)} * g^{(1)}$. A highest weight vector of the algebras $\tilde{L}_{(1)}$ and $g^{(1)}$ is also a highest vector of the three Virasoro algebras, $\tilde{L}_{(1)}$, $\tilde{L}_{(2)}$, and $L_{\text{free}}(X)$. By (C1-4), it is also a highest weight vector for the free Virasoro algebras $\tilde{L}_{(0)} = L_{\text{free}}(\tilde{X})$. Hence, it is a vacuum vector of Fock (X, \tilde{X}) . Its momentum p and \tilde{p} are constrained by the condition (C4-6) and by the highest weight vector condition; they are given by:

$$p_{kj} = \omega_k + \omega_j, \quad \tilde{p}_{kj} = \pm(\omega_k - \omega_j), \tag{C4-7}$$

where ω_k are the weights of level one (with the convention $\omega_0 = 0$).

In particular, we cannot describe a representation whose highest weight is not a sum of two level one weights. These only occur when g is of type D or E . The representations of the $L_{(1)}$ algebra which correspond to these highest weights are characterized by their maximal conformal weight $\Delta_{(1)}[k, j]$. Knowing the value of the conformal weight Δ for the total Virasoro algebra, $L^T = L_{\text{free}}(X) + \tilde{L}_{(2)}$, we can evaluate $\Delta_{(2)}$ by using (A2-8):

$$\frac{\text{Cas}(j, k)}{2(h+2)} = \frac{p^2}{4} + \Delta_{(2)}. \tag{C4-8}$$

We obtain:

$$\Delta_{(1)}(k, j) = \frac{(\omega_k - \omega_j)^2}{2(h+2)}. \tag{C4-9}$$

In the case of the algebras $A_1, A_2,$ and $E_\ell,$ the central charge is less than one: these conformal weights (C4-9) belong to the family of unitary weights (A2-21).

In conclusion, each representation decomposes, with respect to the product $\tilde{L}_{(1)} * g^{(1)}$ as:

$$\tilde{L}_{(1)(c_{(1)}, A_{(1)}(k, j))} \otimes V(\hat{g}, A_k + A_j). \tag{C4-10}$$

Each of these components is twice degenerated due to the symmetry $p \rightarrow -p.$ Up to straightforward modifications, this decomposition can be reproduced for the other constructions presented in the previous sections.

C.5. Basic Representations of $F_4^{(1)}$ and $C_\ell^{(1)}$

The construction of these representations follows from the considerations of Sects. B.6 and C.4. Let g be of type F_4 or $C_\ell.$ Let A_p be the associated short algebra ($p = 2$ or $\ell - 1$) defined in (B6-1). To each root of g we associate a positive root $\tilde{\alpha} = \rho(\alpha)$ of A_p (B6-3). We normalize the long roots of g to $\alpha^{(\ell)} \cdot \alpha^{(\ell)} = 2,$ and those of A_p to $\tilde{\alpha} \cdot \tilde{\alpha} = 1.$ Observe the matching of the central charges of the Virasoro algebra of $g^{(1)}[k = 1],$ Cartan (g) and $L_{(2)}(A_p)$ [Eq. (C4-4)],

$$c(g^{(1)}[k = 1]) = \text{rank}(g) + c_{(2)}(A_p). \tag{C5-1}$$

We will complete the vertex operators associated to the short roots of g by the currents (C4-1), which have conformal weight one half with respect to $L_{(2)}.$

The representation space is,

$$\mathcal{H} = \text{Fock}(X, \tilde{X}) \otimes W(g) \otimes \tilde{W}(A_p). \tag{C5-2}$$

We represent the Cartan subalgebra as usual by $[i\alpha \cdot \partial_z X(z)],$ and the real roots by the currents

$$J(\alpha, z) = \psi(\tilde{\alpha}, z) U(\alpha, z) \hat{e}_\alpha, \tag{C5-3}$$

where the factors are defined by Eqs. (C4-1), (A4-23), and (B6-8)–(B8-12). The O.P.E. of the product $\Psi(\alpha, z)U(\alpha, z)$ is of defined parity, $(-1)^{\alpha\beta + \tilde{\alpha}\tilde{\beta}},$ as in (B6-15). The defect factor $\xi(\alpha, \beta; p)$ (B6-10) is needed here to compensate the extra p -dependent signs which occur when $\tilde{\alpha} \cdot \tilde{\beta} > 0.$ Indeed, in these cases, it is the second term of the O.P.E. (C4-3) which contributes to the poles.

The Virasoro algebra $L_{(1)}(A_p)$ (C1-1) commutes with $g^{(1)}$ and we look for a highest weight of $g^{(1)} \oplus L_{(1)}.$ The momenta (p, \tilde{p}) must satisfy the constraints

$$\forall \alpha, \quad \alpha \cdot p \pm \tilde{\alpha} \cdot \tilde{p} \in \mathbb{Z}. \tag{C5-5}$$

Up to the symmetry $p \rightarrow -p, L_{(1)} \oplus g^{(1)}$ has two and $(\ell + 1)$ highest weight vectors, in the case of F_4 and C_ℓ respectively. They are Fock vacua with momentum $(p, \tilde{p}): p$ a fundamental weight of g and \tilde{p} such that its Dynkin weights $\delta(\tilde{p})$ in A_p are just obtained by restricting the Dynkin diagram of g weighted by $\delta(p)$ to its short roots.

Since the central charge of $L_{(2)}(A_p)$ is more than one, we cannot directly extract the string functions.

D. Character Identities

The explicit constructions, in Chaps. B and C, of several Virasoro* Kac-Moody modules $V(A)$ has enabled us to evaluate a number of string functions

$$C_A^\mu(q) = q^{-\bar{\mu}^2/2k} \text{Tr}_{S_\mu} q^{\tilde{L}_0}. \tag{D-1}$$

Here, A denotes the highest weight of the Virasoro Kac-Moody module, and $\bar{\mu}$ is a weight of the horizontal algebra g_0 . The trace is evaluated over the μ eigenspace of the Cartan subalgebra of g_0 . \tilde{L}_0 denotes the improved Virasoro generator (Sect. A.2) satisfying the commutation relations

$$[\tilde{L}_m, \tilde{L}_n] = (m-n)\tilde{L}_{m+n} + \frac{c}{12} m^3 \delta_{m+n,0} \tag{D-2}$$

without linear dependence in m in the central extension.

The prefactor $q^{(-\bar{\mu}^2/2k)}$ is such that strings which are Weyl conjugated have identical string functions. But the most remarkable property is that string functions of level one module of A, D, E algebras, which are collected in Table 9, have excellent modular properties: they depend on q only through the Dedekind η function (A2-18). To verify Table 9, it is necessary to keep in mind the shift $q^{(-c/24)}$ (A2-9) and the prefactor $q^{(v)}$ corresponding to the energy of the twisted vacuum (A2-25) and (A4-25).

Comparing the bosonic and fermionic constructions of the affine algebras, we can compute several Θ functions.

Remember that, in a given weight diagram, a choice of gradation just corresponds to a choice of the horizontal $L_0 = 0$ hyperplane (Fig. 2). A modification of this choice cannot alter the string functions. Consider for example the

Table 9. Improved string functions of the level one modules of g . These functions do not depend on the gradation. If g_0 is horizontal, the q -dimension of the module is the product of the string function by the Θ function of g_0 (D-2)

$g^{(v)}$	String functions
$A_n^{(1)}, D_n^{(1)}, E_n^{(1)}$	$\eta(q)^{-n}$
$B_n^{(1)}$	$C_0^v = C_v^v = \frac{1}{2} \eta(q)^{-n} \left(\frac{\eta(q)^2}{\eta(q^2)\eta(\sqrt{q})} + \frac{\eta(\sqrt{q})}{\eta(q)} \right)$
	$C_0^v = C_v^0 = \frac{1}{2} \eta(q)^{-n} \left(\frac{\eta(q)^2}{\eta(q^2)\eta(\sqrt{q})} - \frac{\eta(\sqrt{q})}{\eta(q)} \right)$
	$C_s^s = \eta(q^2)\eta(q)^{-n-1}$
$D_{n+1}^{(2)}$	$\eta(\sqrt{q})^{-1} \eta(q)^{-n+1}$
$E_6^{(2)}$	$\eta(q)^{-2} \eta(\sqrt{q})^{-2}$
$A_{2\ell-1}^{(2)}$	$\eta(q)^{-1} \eta(\sqrt{q})^{-\ell+1}$
$A_{2\ell}^{(2)}$	$\eta(\sqrt{q})^{-\ell}$
$D_4^{(3)}$	$\eta(q)^{-1} \eta(q^{1/3})^{-1}$

bosonic construction of $E_6^{(2)}$ with F_4 horizontal. The string function $c(q)$ is given in (B6-19). If we rather consider the gradation with C_4 horizontal, the q -dimension of the basic module is the product of the same string function by the Θ function of the \square coset of the weight lattice of C_4 , scaled to $\alpha \cdot \alpha = 1$. On the other hand, the q -dimension of the same module is given by Eq. (B5-15) via the fermionic construction. Hence:

$$\Theta(\square + C_4)(q) = 8\sqrt{q} \prod_{n>0} (1 - q^{2n})^4 (1 + q^n)^4. \tag{D-3a}$$

In the same way, comparing (B8-6) and (B8-28) we get:

$$\Theta(\square + A_2)(q) = 3q^{1/3} \prod_{n>0} \frac{(1 - q^{3n})^3}{(1 - q^n)}. \tag{D-3b}$$

The same method, applied to $A_6^{(2)}$ yields the well known Θ functions of the orthogonal series B and D .

We shall now try to gain some information on the character of several higher representations by combining the method of Goddard, Kent, and Olive (A4-25) with the classical results of Dynkin.

Consider a finite Lie algebra g , a subalgebra h of g , and let $e(\beta)$ denote the generator of g corresponding to the highest weight of the adjoint representation of h . Equation (A1-20) particularized to the generators $e(\beta)$ and $e(-\beta)$,

$$[t^m \otimes e_\beta, t^n \otimes e_{-\beta}] = t^{m+n} \otimes (\beta \cdot h) + m(\beta, \beta) \gamma^k \delta_{m+n,0} \tag{D-4}$$

indicates the level k of the $h^{(1)}$ representation inside the $g^{(1)}$ representation of level k . Recalling that the standard bilinear form is normalized in such a way that the square of the long root ϕ of g is two, we find;

$$k_h = k_g \frac{(\phi, \phi)}{(\beta, \beta)} = k_g j(g/h), \tag{D-5}$$

where $j(g/h)$ is the Dynkin index of the embedding of h in g .

We may now evaluate the central charge of the Virasoro algebra of (g/h) (A2-25). If $c(g/h)$ is less than one, the g -module splits into a finite number of h -modules since in that case, $L(g/h)$ has a finite number of unitary conformal weights $\Delta_{r,s}$ [(A2-21) and Table 6].

Let A be the highest weight of the $g^{(1)}$ -module $V(A)$. Let $\Delta_g(A)$ denote its conformal weight with respect to the $g^{(1)}$ Virasoro algebra

$$\Delta_g(A) = \frac{\text{Cas}_g(A)}{2(k_g + h_g)}. \tag{D-6a}$$

If a weight μ of $V(A)$ is a highest weight of $h^{(1)}$, it is also a highest weight of $L(h)$ with conformal weight,

$$\Delta_h(\mu) = \frac{\text{Cas}_h(\mu)}{2(k_h + h_h)}. \tag{D-6b}$$

However, μ necessarily belongs to some unitary module of $L(g/h)$, with conformal weight $\Delta_{r,s}$. Hence,

$$\exists r, s / \Delta_g(A) - \Delta_h(\mu) - \Delta_{rs} \in \mathbb{N}. \tag{D-7}$$

When $c(g/h)$ is less than one, this constraint selects a small number of possible highest weights of $h^{(1)} * L(g/h)$ inside $V(A)$. One may check by computing the degeneracy of a few levels of $V(A)$ whether they occur.

Let us first illustrate this method in the case $c(g/h)=0$. Consider a maximal regular subalgebra h of a simply laced Lie algebra g . The Dynkin index is one and $c(g/h)$ automatically vanishes. For example, by looking at the subalgebra $D_8^{(1)}$ of $E_8^{(1)}$ in the homogeneous gradation, one obtains the decomposition,

$$ch(E_8, \text{basic}) = ch(D_8, \text{scalar}) + ch(D_8, \text{spin}). \tag{D-8}$$

Using the Bardakci-Halpern (B3-10) and the Frenkel-Kac constructions (B2-15), we derive the character identity:

$$\begin{aligned} \Theta_{E_8}(q) = & \left\{ \frac{1}{2} \left(\prod_{n>0} (1 + q^{n-1/2})^{16} + \prod_{n>0} (1 - q^{n-1/2})^{16} \right) \right. \\ & \left. + 128q \prod_{n>0} (1 + q^n)^{16} \right\} \prod_{n>0} (1 - q^n)^8. \end{aligned} \tag{D-9}$$

This identity plays an important role in the heterotic string models.

In the twisted construction of $E_8^{(1)}$ (Sect. B.5), we find the alternative identity:

$$\begin{aligned} ch(E_8, \text{basic}) = & ch(D_8, \text{vector}) + ch(D_8, \text{spin}) \\ = & 16\sqrt{q} \prod_{n>0} (1 - q^{n-1/2})^{-8}, \end{aligned} \tag{D-10}$$

which is equivalent to the Jacobi identity (B2-17).

Looking at non-regular subalgebras, we may obtain a large value of the Dynkin index, and hence a h -representation of high level. For instance, B_2 has an A_1 subalgebra of index 10 (Fig. 6). The three level one representations of $B_2^{(1)}$ decompose as

$$\tag{D-11}$$

All the possible highest weight A_h appear in the decompositions. Indeed, the first two representations are conjugated by the outer automorphism which exchanges the two long roots of $B_2^{(1)}$; this shows that the two representations of $A_1^{(1)}$ participate to these decompositions. The $B_2^{(1)}$ -spinor representation is real under this automorphism which implies that the two complex conjugate representations (3 \circ \circ 7) and (7 \circ \circ 3) are present in the decomposition. No other representations of level 10 of $A_1^{(1)}$ satisfies Eq. (D.7). These decompositions relate the string functions of a level ten representation of $A_1^{(1)}$ to those of a level one representation of $B_2^{(1)}$.

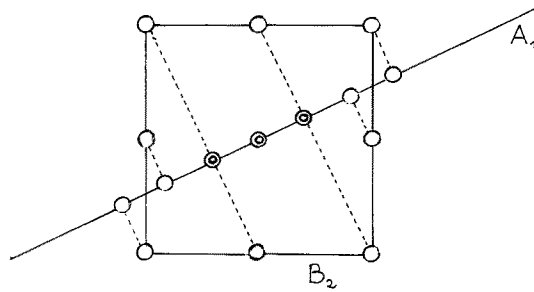

Fig. 6. The irregular subalgebra A_1^{10} of B_2 (D-11). This diagram shows the restriction $10 = 3 + 7$ of the adjoint representation of B_2 to A_1

Table 10. Irregular subalgebras of the exceptional Lie algebras such that the central charge of the Virasoro algebra $L(g/h)$ is less than 1. $j(g/h)$ is the index of the imbedding of h in g . $c(g/h)$ actually vanishes in all cases except $F_4 \subset E_6$

g	$h^{j(g/h)}$
G_2	A_1^{28}
F_4	$G_2^1 + A_1^8$
E_6	$A_2^9, G_2^3, C_4^1, G_2^1 + A_2^2, F_4^1$ ($c(g/h) = 4/5$)
E_7	$A_2^{21}, G_2^1 + C_3^1, F_4^1 + A_1^3, G_2^2 + A_1^7$
E_8	$G_2^1 + F_4^1, A_2^6 + A_1^{16}, B_2^{12}$

The work of Dynkin contains many more examples. We present in Table 10 part of his classification of the non-regular subalgebra of the exceptional Lie algebras which we read as the splitting of the level one modules of $g^{(1)}$ as level $j(g/h)$ modules of $h^{(1)}$. We have included those subalgebras such that the central charge of the Virasoro algebra $L(g/h)$ is less than one.

Let us first consider the decomposition of the E_6 with respect to F_4 , in which the central charge $c(g/h) = 4/5 < 1$. The highest conformal weight of the scalar representations of $E_6^{(1)}$ are 0 and $2/3$. Those of the scalar and 26 representations of $F_4^{(1)}$ are 0 and $3/5$. Therefore, we obtain the decompositions:

$$\begin{array}{l}
 \begin{array}{c} \circ - \circ - \circ - \circ \\ \quad \quad \quad \diagup \quad \diagdown \\ \quad \quad \quad \circ \quad \quad \circ \end{array} \quad \downarrow \quad \begin{array}{c} \circ - \circ - \circ - \circ \\ \quad \quad \quad \diagup \quad \diagdown \\ \quad \quad \quad \circ \quad \quad \circ \end{array} \quad \otimes \quad [(0) + (3)] \\
 \oplus \quad \begin{array}{c} \circ - \circ - \circ - \circ \\ \quad \quad \quad \diagup \quad \diagdown \\ \quad \quad \quad \circ \quad \quad \circ \end{array} \quad \otimes \quad [(2/5) + (7/5)] \\
 \hline
 \begin{array}{c} \circ - \circ - \circ - \circ \\ \quad \quad \quad \diagup \quad \diagdown \\ \quad \quad \quad \circ \quad \quad \circ \end{array} \quad \downarrow \quad \begin{array}{c} \circ - \circ - \circ - \circ \\ \quad \quad \quad \diagup \quad \diagdown \\ \quad \quad \quad \circ \quad \quad \circ \end{array} \quad \otimes \quad (2/3) \\
 \oplus \quad \begin{array}{c} \circ - \circ - \circ - \circ \\ \quad \quad \quad \diagup \quad \diagdown \\ \quad \quad \quad \circ \quad \quad \circ \end{array} \quad \otimes \quad (1/15)
 \end{array}
 \tag{D-12}$$

where (Δ) denotes the representation $(c = 4/5, \Delta)$ of the Virasoro algebra. Equation (D2-12) is sufficient to find the q -dimension of the level one representations of the affine algebra $F_4^{(1)}$.

As a last application, we consider the imbedding

$$E_8^{(1)} \supset F_4^{(1)} \oplus G_2^{(1)}. \tag{D-13}$$

The central charge $c = 8$ of the Virasoro algebra associated to the eight free fields involved in the Frenkel-Kac construction of $E_8^{(1)}$ (Sect B.2) splits into $(4 + 2)$ associated to the Cartan subalgebra of F_4 and G_2 , plus $(6/5 + 4/5)$ associated to the auxiliary A_2 algebra (Chap, C). It follows that the basic module of $E_8^{(1)}$ restricts to

$$\begin{array}{ccccc}
 \begin{array}{c} 1 \\ \circ - \circ - \circ \rightarrow \circ - \circ \end{array} & \otimes & \begin{array}{c} \circ \times \end{array} & \begin{array}{c} 1 \\ \circ - \circ \rightarrow \circ \end{array} & \\
 \oplus & & \otimes & & \\
 \begin{array}{c} \oplus \\ \circ - \circ - \circ \rightarrow \circ - \circ \end{array} & & \begin{array}{c} \circ \times \end{array} & & \begin{array}{c} 1 \\ \circ - \circ \rightarrow \circ \end{array}
 \end{array} \tag{D-14}$$

Comparing (D-12), (D-14) and the character of the level one modules of $E_8^{(1)}$ (Sect. B.2) and $G_2^{(1)}$ (Sect. C), we infer identities between the theta functions of the $E_6, E_8,$ and G_2 weight lattices.

The method can be applied to many, many examples ...

Conclusion

Using the methods of quantum field theory, we have constructed the level one modules of all the simple affine Kac-Moody algebras in all their homogeneous gradations. On the way, we have constructed several level two representations of the A, D, E algebras and the representations of $A_1^{(1)}$ of arbitrary level.

Chapter A is intended to provide a relatively self contained introduction to the Kac-Moody and their associated Virasoro algebras, in a language accessible to physicists. We follow quite closely the notations of the book of Kac [1] except in the analysis of the gradings of the twisted algebras (A 1-16).

The constructions are explained in Chaps. B and C. The crucial element is the value of the central charge, c , of the associated Virasoro algebra. When c is integral (Chap. B), we are able to construct a positive definite Hilbert space carrying an irreducible Kac-Moody module. We have defined two types of constructions: bosonic and fermionic. In the bosonic constructions, the horizontal Cartan subalgebra is represented by the zero modes of a system of free Fubini-Veneziano oscillators. The long roots are represented by the Frenkel-Kac vertex operators; the short roots, by a generalization of the Neveu-Schwarz-Ramond vertex operators involving entangled non-abelian Neveu-Schwarz and Ramond fields (A4-37), (B6-14). A major modification needed to generalize the work of Frenkel-Kac [14] to the twisted version of the A, D, E algebras (Sect. B.6) is the fact that the Chevalley structure constants no longer define a two-cocycle (B6-11). In the fermionic constructions, also considered by Lepowski [19, 24] and by Kac-Peterson [25], the oscillators have no zero modes and the vertex operators are completed by Dirac matrices (B5-14).

When c is not integral (Chap. C), our constructions are irreducible only as $(\text{Virasoro})' * (\text{Kac-Moody})$ modules, where $(\text{Virasoro})'$ denotes an auxiliary algebra defined as follows: We complete the Frenkel-Kac currents associated to the short roots by a set of primary fields of a Virasoro algebra L which can be regarded as the stress-tensor of an interacting field theory (Sect. C.1). $(\text{Virasoro})'$, defined in the same Hilbert space, appears as a complement of L commuting with the Kac-Moody algebras. We construct in this way the level one representations of the algebras $F_4^{(1)}$, $C_\ell^{(1)}$, and $G_2^{(1)}$, and the level two of the simply laced algebras. In their parallel work, Goddard et al. [47] introduce similar auxiliary fields, but an apparently different system of ε operators.

Chapter D illustrates how one may relate various constructions of the same modules and derive in this way arithmetical identities.

We hope that these constructions will prove useful in statistical mechanics and string theory.

Appendix. The Chevalley Structure Constants

The Chevalley structure constants $f(\alpha, \beta)$ are defined if and only if α , β , and $\alpha + \beta$ are roots of g by the relation:

$$[e_\alpha, e_\beta] = f(\alpha, \beta)e_{\alpha+\beta}. \tag{1}$$

By construction, they are antisymmetric:

$$f(\alpha, \beta) = -f(\beta, \alpha). \tag{2}$$

Furthermore, if all the double commutators are non-zero, the Jacobi identity implies:

$$f(\alpha, \beta)f(\alpha + \beta, \gamma) + f(\beta, \gamma)f(\beta + \gamma, \alpha) + f(\gamma, \alpha)f(\gamma + \alpha, \beta) = 0. \tag{3}$$

If g is of type A, D, E , the square length of every root is 2. Hence, α , β , and $\alpha + \beta$ are roots if and only if $\alpha \cdot \beta = -1$. Because of this constraint, the Jacobi identity involves only 2 terms and reduces to:

$$f(\alpha, \beta)f(\alpha + \beta, \gamma) = f(\alpha, \beta + \gamma)f(\beta, \gamma). \tag{4}$$

By inspection, this is also true for the algebras of type B and G . In these cases, we may recursively rescale the generators so that:

$$f_{\text{rescaled}}(\alpha, \beta) = \varepsilon(\alpha, \beta) = \pm 1 \tag{5}$$

and by (4) and (5), the ε define a 2-cocycle on $\Delta(g)$.

In contradistinction, if g has more than one short simple root (type C and F), Jacobi identities involving 3 non-vanishing double commutators occur. One may not reduce (3) and (4). The f do not form a 2-cocycle and cannot be rescaled to ± 1 . A modified construction is explained in Sect. B.6.

If g is of type A, B, D, E, G , we may choose the signs of the generators e_α in such a way that the ε are bimultiplicative:

$$\begin{aligned} \varepsilon(\alpha + \beta, \gamma) &= \varepsilon(\alpha, \gamma)\varepsilon(\beta, \gamma), \\ \varepsilon(\alpha, \beta + \gamma) &= \varepsilon(\alpha, \beta)\varepsilon(\alpha, \gamma). \end{aligned} \tag{6}$$

This choice considerably simplifies all calculations. However, despite [14], it is not possible to assume bimultiplicativity and $\varepsilon(\alpha, \alpha) = +1$ on all the roots. Indeed, if α , β , and $\alpha + \beta$ are roots, (6) implies:

$$\varepsilon(\alpha + \beta, \alpha + \beta) = -\varepsilon(\alpha, \alpha)\varepsilon(\beta, \beta). \quad (7)$$

This impossibility leads to a complication in the definition of Hermitic Frenkel-Kac currents [Eqs. (B2-3) and (B2-14)] which is usually overlooked.

Acknowledgements. It is a pleasure to thank Victor Kac and Jean-Bernard Zuber for so many explanations and suggestions all over the year. We are grateful to Alex Feingold, Claude Itsykson, Dale Peterson, Jim Patera, and J. Todorov for fruitful and interesting discussions and to Peter Goddard, David Olive, and Adam Schwimmer for stimulating comparisons of our results.

References

1. Kac, V.G.: Infinite dimensional Lie algebras. Cambridge: Cambridge University Press 1985
2. Kac, V.G., Peterson, D.H.: Infinite dimensional Lie algebras, theta functions, and modular forms. *Adv. Math.* **53**, 125–264 (1984)
3. Kac, V.G.: Simple graded Lie algebras of finite growth. *Funkts. Anal. Prilozh.* **1**, 82–83 (1967) [English transl. **1**, 328–329 (1967)]; Simple irreducible Lie algebras of finite growth. *Izv. Akad. Nauk. SSSR* **32**, 1323–1367 (1968) [English transl. **2**, 1271–1331 (1968)]
4. Moody, R.: Lie algebras associated with generalized Cartan matrices. *Bull. Am. Math. Soc.* **73**, 217–221 (1967); A new class of Lie algebras. *J. Algebra* **10**, 211–230 (1968)
5. Gell-Mann, M.: Symmetries of Baryons and Mesons. *Phys. Rev.* **125**, 1067–1084 (1962)
Coleman, S., Gross, D., Jackiw, R.: Fermions avatars of the Sugawara model. *Phys. Rev.* **180**, 1359–1366 (1969)
6. Veneziano, G.: Construction of a crossing symmetric, Regge behaved amplitude for linearly rising trajectory. *Nuovo Cimento* **57A**, 190–197 (1968)
Fubini, S., Veneziano, G.: Level structure of dual resonance models. *Nuovo Cimento* **64A**, 811–840 (1969)
Scherk, J.: An introduction to the theory of dual models and strings. *Rev. Mod. Phys.* **47**, 123–154 (1975)
7. Virasoro, M.: Subsidiary conditions and ghost in dual resonance models. *Phys. Rev. D* **1**, 2933–2936 (1970)
8. Ramond, P.: Dual theory for free fermions. *Phys. Rev. D* **3**, 2415–2418 (1971)
Neveu, A., Schwarz, J.: Factorizable dual model of pions. *Nucl. Phys. B* **31**, 86–112 (1971); Tachyon-free dual model with a positive intercept trajectory. *Phys. Lett.* **34B**, 517–518 (1971)
9. Bardakci, K., Halpern, M.: New dual quark models. *Phys. Rev. D* **3**, 2493–2506 (1971)
Halpern, M.: Quantum “solitons” which are $SU(N)$ fermions. *Phys. Rev. D* **12**, 1684–1699 (1975)
10. Skyrme, T.H.: A non-linear theory of strong interactions. *Proc. Roy. Soc. A* **247**, 260–278 (1958); Particles states of a quantized meson field. *Proc. Roy. Soc. A* **262**, 237–245 (1961)
Coleman, S.: Quantum sine-Gordon equation as the massive Thirring model. *Phys. Rev. D* **11**, 2088–2097 (1975)
Mandelstam, S.: Soliton operators for the quantized sine-Gordon equation. *Phys. Rev. D* **11**, 3026–3030 (1975)
11. Kac, V.G.: Infinite dimensional Lie algebras and Dedekind’s η function. *Funkts. Anal. Prilozh.* **8**, 77–78 (1974) [English transl. **8**, 68–70 (1974)]
12. Kac, V.G.: Contravariant form for infinite dimensional Lie algebras and superalgebras. *Group Th. Methods in Physics. Lecture Notes in Physics, Vol. 94.* Berlin, Heidelberg, New York: Springer 1979, pp. 441–445

13. Lepowski, J., Wilson, R.L.: Construction of the affine algebra $A_1^{(1)}$. *Commun. Math. Phys.* **62**, 43–53 (1978)
14. Frenkel, I., Kac, V.G.: Basic representations of affine Lie algebras and dual resonance models. *Invent. Math.* **62**, 23–66 (1980)
15. Segal, G.: Unitary representation of some infinite dimensional groups. *Commun. Math. Phys.* **80**, 301–342 (1981)
16. Kac, V.G., Kazhdan, D.A., Lepowski, J., Wilson, R.L.: Realization of the basic representations of the euclidean Lie algebras. *Adv. Math.* **42**, 83–112 (1981)
17. Frenkel, I.: Two constructions of affine Lie algebras. Representations and boson-fermion correspondence in Q.F.T. *Funct. Anal. Appl.* **44**, 259–327 (1981)
18. Witten, E.: Non-abelian bosonization in two dimensions. *Commun. Math. Phys.* **92**, 455–472 (1984)
19. Frenkel, I., Lepowski, J., Meurman, A.: A natural representation of the Fischer-Griess monster with the modular J function as character. *Proc. Natl. Acad. Sci. USA* **81**, 3256–3260 (1984); An E_8 approach to F_1 . *Contemp. Math.* **45**, 99–120 (1985)
20. Gross, D.J., Harvey, J.A., Martinec, E., Rohm, R.: Heterotic string theory I: The free heterotic string. *Nucl. Phys. B* **256**, 253–284 (1985)
21. Benkart, G.: A Kac-Moody bibliography and some related references. *Can. Math. Bull.* **5**, 111–135 (1986)
22. Schwarz, J. (ed.): *Superstrings, the first fifteen years*. New York: World Scientific 1985
23. Goddard, P., Kent, A., Olive, D.I.: Virasoro algebras and coset space models. *Phys. Lett.* **152 B**, 88–92 (1985)
24. Lepowski, J.: Calculus of twisted vertex operators. *Proc. Natl. Acad. Sci. USA* **82**, 8295–8299 (1985)
25. Kac, V.G., Peterson, D.H.: 112 constructions of the basic representations of the loop group E_8 . In: *Geometry, anomalies, topology*. Bardeen, W.A., White, A.R. (eds.). Singapore: World Scientific 1985
26. Eguchi, T., Higashijima, K.: Vertex operators and non-abelian bosonization. In: *Recent developments in Q.F.T.* Ambjorn, J. et al. (eds.). London: Elsevier 1985
27. Fateev, V.A., Zamolodchikov, A.B.: Parafermionic currents in the two dimensional conformal quantum field theory and self-dual critical point in Z_N -invariant statistical systems. *Zh. E.T.F.* **90**, 1553–1562 (1986)
28. Goddard, P., Olive, D.I.: Algebras, lattices, and strings. In: *Vertex operators in math. and phys.*, MSRI 3. Lepowski, J. et al. (eds.). Berlin, Heidelberg, New York: Springer 1984
29. Belavin, A.A., Polyakov, A.M., Zamolodchikov, A.B.: Infinite conformal symmetry in two-dimensional quantum field theory. *Nucl. Phys. B* **241**, 333–386 (1984)
30. Friedan, D., Qiu, Z., Shenker, S.: Conformal invariance, unitary and two-dimensional critical exponents. *Phys. Rev. Lett.* **52**, 1575–1578 (1984); and in *Vertex operators ...* p. 419
31. Friedan, D., Shenker, S., Qiu, Z.: Details of the non-unitary proof for highest weight representations of the Virasoro algebra. *Commun. Math. Phys.* **107**, 179–212 (1986) Langlands, R.: Montreal University preprint, June 1986
32. Feigen, B.L., Fuchs, D.B.: Invariant skew-symmetric differential operators on the line and Verma modules over the Virasoro algebra. *Funct. Anal. Appl.* **16**, 114–126 (1982); Verma modules over the Virasoro algebra. *Funct. Anal. Appl.* **17**, 241–242 (1983)
33. Rocha-Caridi, M.: Vacuum vector representations of the Virasoro algebra, in *Vertex operators ...* p. 451–473
34. Goddard, P., Kent, O., Olive, D.I.: Unitary representations of the Virasoro and super-Virasoro algebras. *Commun. Math. Phys.* **103**, 105–119 (1986)
35. Kac, V.G., Wakimoto, M.: Unitary highest weight representations of the Virasoro, Neveu-Schwarz, and Ramond algebras. In: *Proceedings of the symposium on conformal groups and structures*, Clausthal 1985. *Lecture Notes in Physics*. Berlin, Heidelberg, New York: Springer
36. Feingold, A.J., Lepowski, J.: The Weyl-Kac character formulae and power series identities. *Adv. Math.* **29**, 271–309 (1978)

37. Knizhnik, V.G., Zamolodchikov, A.B.: Current algebra and Wess-Zumino model in two dimensions. *Nucl. Phys. B* **247**, 83–103 (1984)
Friedan, D., Martinec, E., Shenker, S.: Conformal invariance, supersymmetry and string theory. Princeton preprint
38. Gliozzi, F., Olive, D.I., Scherk, J.: Supergravity and spinor dual model. *Phys. Lett.* **65 B**, 282–285 (1976)
39. Kac, V.G., Peterson, D.H.: Spin and wedge representations of infinite Lie algebras and groups. *Proc. Natl. Acad. Sci. USA* **78**, 3308–3312 (1981)
40. Frenkel, I.B.: Spinor representations of affine Lie algebras. *Proc. Natl. Acad. USA* **77**, 6303–6306 (1980)
41. Lepowski, J., Primc, M.: Structure of the standard modules for the affine Lie algebra $A_1^{(1)}$ in the homogeneous picture, in *Vertex operators ...* p. 143–162
42. Alvarez, O., Mangano, M., Windey, P.: Berkeley preprint 1986
43. Bourbaki, N., *Groupes et algèbres de Lie*, Chapitre 6. Paris: Hermann 1968
44. Itzykson, C., Zuber, J.B.: Two-dimensional conformal invariant theories on a torus. *Nucl. Phys. B* **275**, 580–592 (1986)
45. Kac, V.G., Peterson, D.H.: Affine Lie algebras and Hecke modular forms. *Bull. Am. Math. Soc.* **3**, 1057–1061 (1980)
46. Bais, F.A., Englert, F., Taormina, A., Zizzi, P.: Torus compactification for non simply laced groups. Preprint ULB-TH 85/05
47. Goddard, P., Nahm, W., Olive, D.I., Schwimmer, A.: Vertex operators for non-simply laced algebras. *Commun. Math. Phys.* **107**, 179–212 (1986)

Communicated by A. Jaffe

Received August 28, 1986