

The effect of rotation on the eutectic phase in hypoeutectic Al-Si alloy

P. S. BASAK, B. C. RAY, I. CHAKRABARTY

Department of Metallurgical Engineering, Indian Institute of Technology, Kharagpur 721 302, India

Numerous investigations have been made to visualize the effect of rotation and/or stirring during the solidification of molten Al-Si alloys [1-4]. Several beneficial effects can be achieved from this stirring; namely, elimination of macrosegregation as a result of an increase in interdendritic convection, finer grain structure, better surface finish, etc. Of the different modes of stirring, electromagnetic stirring results in spheroidization of α -phase and the development of a finer structure by fragmentation of dendrites in Al-7% Si and Al-4.2% Si alloys [3, 4]. The effect of centrifugal rotation of Al-5% Si was studied long ago [1]. Unfortunately, no encouraging results were obtained, probably due to the high rotational speeds. A low or moderate rotational speed appears to yield fruitful results. Little attention has been paid to studying such a range of rotational speeds for Al-9% Si alloys. Therefore, this study aimed to focus on the effect of low or moderate rotational speeds on the microstructural evolution of Al-9% Si alloy.

The alloy was melted in an electrical resistance furnace and poured into the mechanical rotating device at a pouring temperature of 750 °C. The metal mould was preheated at 250 °C. Fig. 1 shows a cross-sectional view of the device. The liquid alloy was subjected to different rotational speeds: 42, 61, 93 and 113 r.p.m. Transverse sections (from the middle portion) of the solidified castings were studied by optical and scanning electron microscopy (SEM). The fractions of eutectic phase were measured by quantitative metallography. The hardness profiles from the centre to the edge were measured on the Rockwell B scale.

The optical micrographs (Fig. 2) at the edges reveal a chilled structure at 42, 61 and 93 r.p.m., whereas the dendritic structure is apparent at a speed of 113 r.p.m., probably due to remelting at

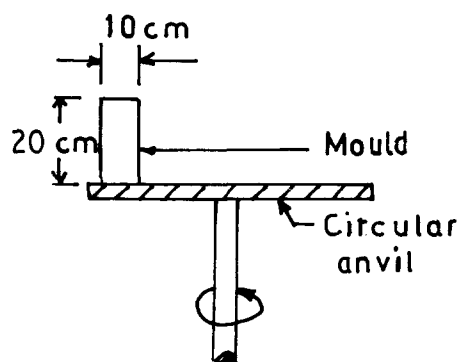

Figure 1 The mechanical rotating device.

the surface by a strong flow of liquid towards the outwards portion [5]. The micrographs (Fig. 3) at the centre show that the eutectic phase at first decreases and then rises with increasing rotational speed. This is supported by the fraction of eutectic phase measured, as illustrated in Fig. 4. The corresponding SEM micrographs (Fig. 5) indicate that the silicon plates are becoming broken and dispersed at the centres at increasing rotational speeds. There is hardly any difference between the SEM micrographs of centres and edges with rotational speeds of 42, 61 and 93 r.p.m. However, in the case of the higher rotational speed (113 r.p.m.) a marked difference between the centre and the edge could be observed. At the edge silicon becomes coagulated [6].

The hardness versus distance plots are shown in Fig. 6. The hardness profiles from the centre to the edge are in conformity with the microstructural

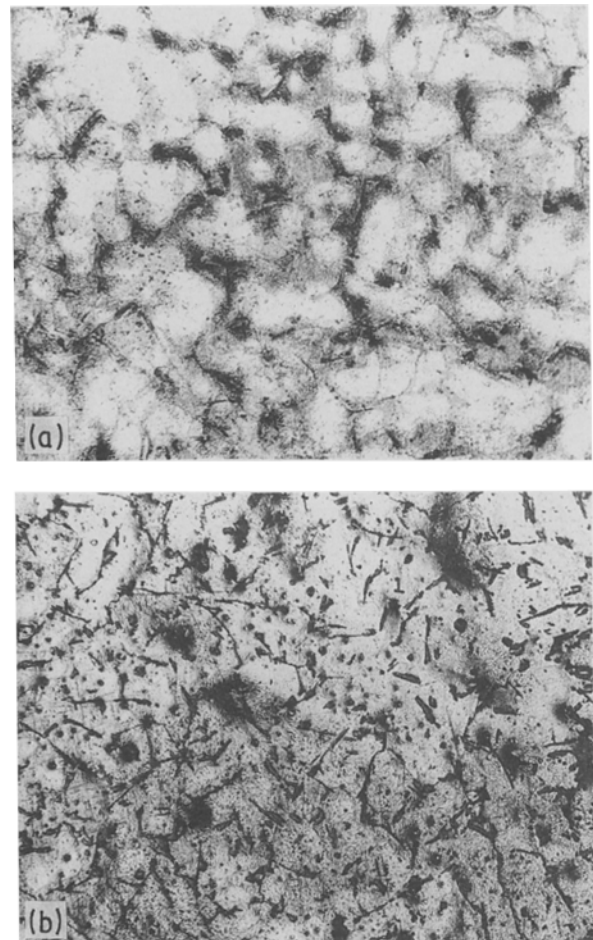

Figure 2 Optical micrographs at the edge at (a) 93 and (b) 113 r.p.m. ($\times 85$).

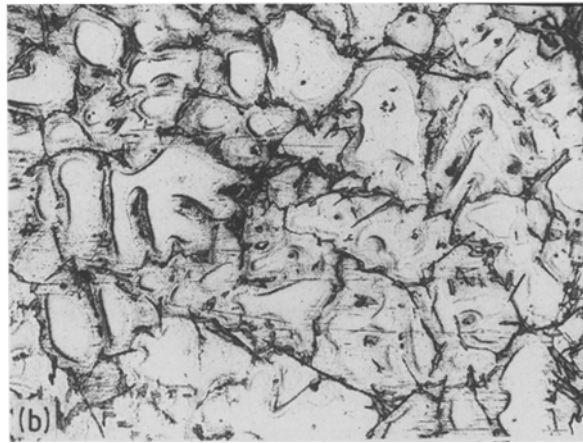
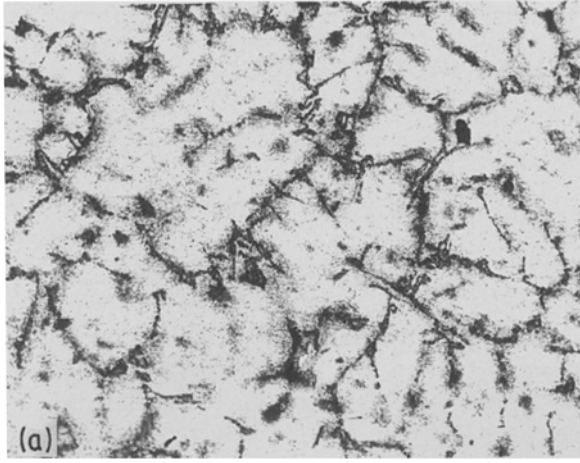

Figure 3 Optical micrographs at the centre at (a) 61 and (b) 113 r.p.m. ($\times 85$).

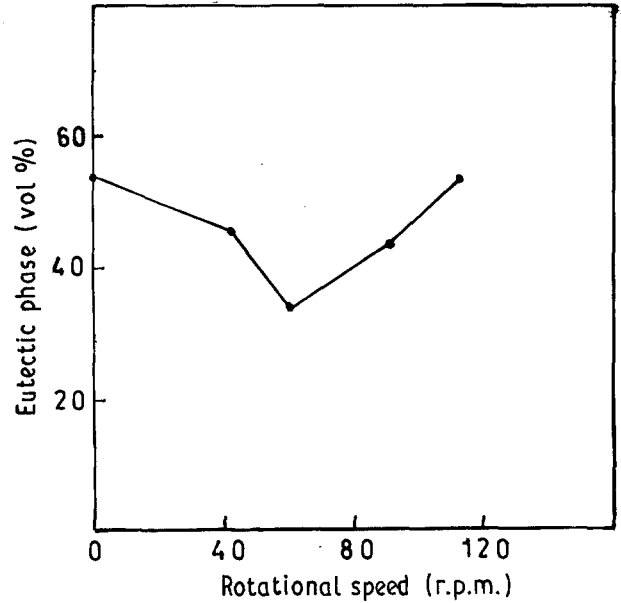

Figure 4 Plot of vol % eutectic phase versus rotational speed.

features. The hardness at the edge for the 113 r.p.m. casting was found to be higher than that of the others, due to agglomeration of silicon. It is evident that a uniform distribution of eutectic phase throughout the cross-section of a casting can be achieved by rotation with lower rotational speed. However, at higher speed the nature of the hardness profile suggests that the distribution profile is reversed, as observed in Sn-12% Pb alloy [5].

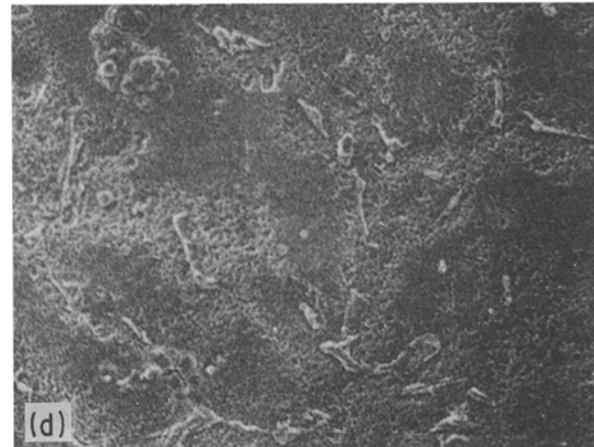
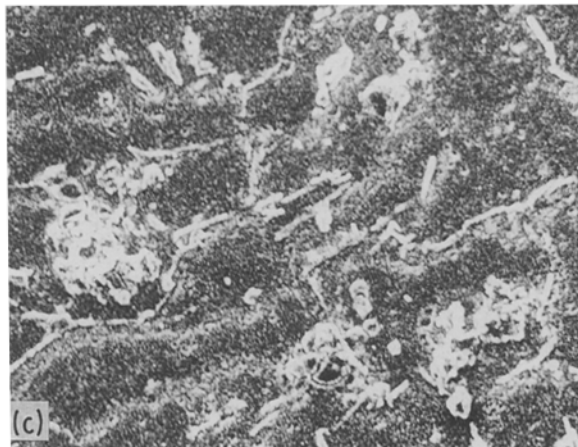
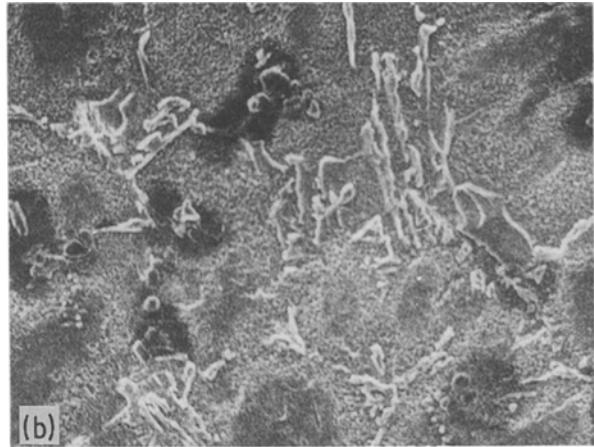
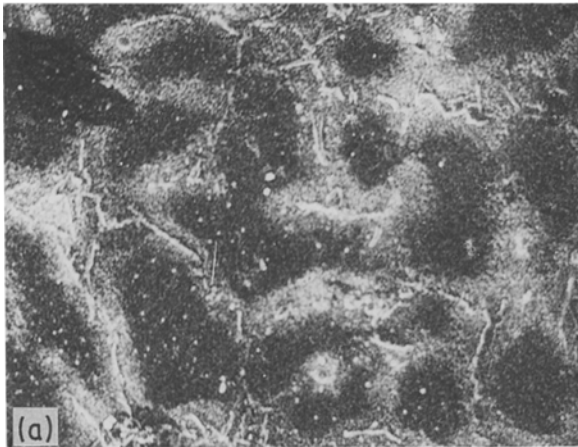

Figure 5 SEM micrographs of (a) edge at 93 r.p.m., (b) centre at 93 r.p.m., (c) edge at 113 r.p.m. and (d) centre at 113 r.p.m. ($\times 300$).

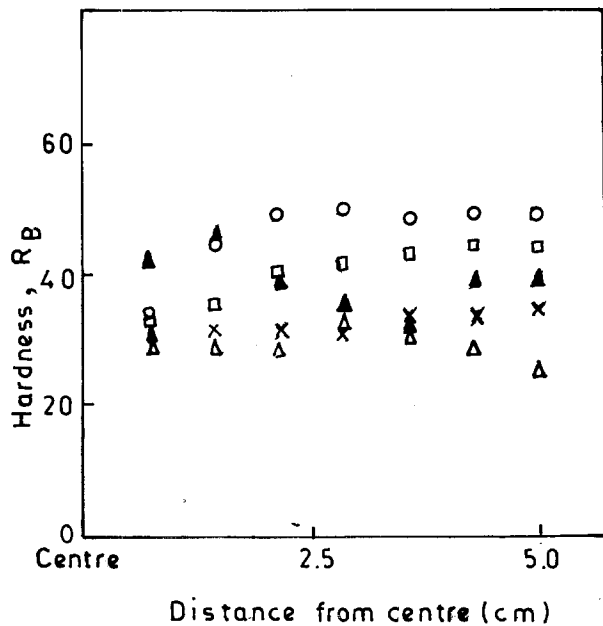

Figure 6 Variation of hardness with distance from the centre. Rotational speed: (○) 0, (□) 42, (×) 61, (△) 93 and (▲) 113 r.p.m.

The following conclusions can be drawn based on the experimental evidence. Rotation in liquid Al-9% Si alloy causes refinement of the eutectic morphology. Up to a certain critical speed the

homogeneity and dispersity of the eutectic structure increases with increasing rotational speed, but beyond that speed limit the coagulation of Si occurs at the surface, probably due to reversing of concentration profile.

Acknowledgement

The authors are greatly thankful to Professor B. Chakraborty, Department of Metallurgical Engineering, Jadavpur University, for valuable discussions.

References

1. A. COUTURE, *Trans AFS* **75** (1968) 42.
2. S. SARKAR, M. J. BANERJEE and A. K. SEAL, *Trans IIM* **38** (1985) 139.
3. N. FAT-HALLA, P. SECORDEL and M. SUERY, *J. Mater. Sci.* **23** (1988) 2419.
4. D. A. CURREY and C. A. PICKLES, *ibid.* **23** (1988) 3756.
5. S. KOU, D. R. POIRIER and M. C. FLEMINGS, *Met. Trans.* **9B** (1978) 711.
6. A. CLARO, J. FAVA and R. A. FLIME, *Trans AFS* **78** (1970) 324.

Received 6 April 1989
and accepted 7 July 1989