

A complex allorecognition system in a reef-building coral: delayed responses, reversals and nontransitive hierarchies

N. Chadwick-Furman¹ and B. Rinkevich²

¹ Interuniversity Institute, H. Steinitz Marine Biology Laboratory, PO Box 469, Eilat, Israel

² National Institute of Oceanography, Israel Oceanographic and Limnological Research, Tel-Shikmona, PO Box 8030, Haifa 31080, Israel

Accepted 19 May 1993

Abstract. A highly polymorphic and complex allorecognition system in the coral *Stylophora pistillata* was revealed in the field by assaying branch pair combinations among 11 colonies (181 assays) for 24 months. Replicates of between-colony combinations exhibited consistent outcomes, in both time scale and type of response. Different allogeneic combinations exhibited one of two main outcomes, either unilateral rejection, or an array of other incompatible reactions following a state of “non-fusion”. These responses were partially linked with color morphs (purple dominated yellow). An additional 22 isogenic grafts resulted in complete fusion. Unilateral rejection occurred 1–7 months following initial contact. Nonfusion usually developed into skeletal suture barriers after 3–9 months, and then into unilateral colony-specific overgrowths at 6–23 months with some reversals in direction at 18–22 months. During this process, small lesions usually developed on the tissue of the subordinate partner, which were either overgrown by the dominant partner or healed. After two years, a network of overgrowths among colonies was established with essentially hierarchical properties, but some nontransitive interactions also occurred. The colonies segregated into three distinct histocompatibility groups; within each group, colonies engaged in nonfusion. Between groups, colonies exhibited nonfusion or rejected each other in a group-specific manner. Based on the results, we discuss the terminology used for fusion versus rejection phenomena in scleractinian corals, the possible genetic background for self-nonsel self recognition in *Stylophora*, and the methodological artifacts associated with the use of short-term allorecognition assays.

Introduction

The study of invertebrate immunity, although still fragmentary, has revealed that discrimination between self and

nonsel self is a common biological characteristic for a variety of groups, from protozoans (Beale 1990) and sponges (Hildemann et al. 1979, 1980) to the most advanced invertebrates, the protochordates (Bancroft 1903; Sabbadin 1962; Scofield et al. 1982). Knowledge of the genetic basis for invertebrate histocompatibility may hold promising avenues for comparative immunological research. In several invertebrates, the capacity for self/nonsel self recognition among conspecifics resides in a single but remarkably polymorphic gene locus, either with multiple codominantly expressed alleles (as in botryllid ascidians: Oka and Watanabe 1960; Sabbadin 1962; Scofield et al. 1982; and in an athecate colonial hydroid: Hauenschild 1954) or with heterozygotic dominance (as in ciliates: Beale 1990). In other invertebrates, historecognition is controlled by several discrete haplotypes at two or more loci (as in solitary ascidians: Fuke and Nakamura 1985; Kingsley et al. 1989; Raftos and Briscoe 1990). These examples, which indicate the variety of genetic mechanisms in invertebrates, emphasize the need for additional information before comparing invertebrate and vertebrate immune systems.

Scleractinian reef-building corals are characterized by a surprising complexity of specific allorecognition responses (Hildemann et al. 1975; Potts 1976; Bak and Criens 1982; Rinkevich and Loya 1983a; Müller et al. 1984; Hidaka 1985; Willis and Ayre 1985). These precise histocompatibility responses require both an allorecognition system that is capable of detecting subtle differences among conspecifics, and sufficient genetic variation so that relatedness can be inferred reliably from shared parts of the genome (Grosberg and Quinn 1989). While allorecognition responses in cnidarians have been shown to be ecologically relevant (Potts 1976; Rinkevich and Loya 1983a, b, 1985; Willis and Ayre 1985; Cornesky 1991), they have attracted the interest of comparative immunologists, some of whom view coral histocompatibility elements as possible evolutionary precursors to vertebrate T-cell mediated allotransplantation responses (Burnet 1971; Hildemann et al. 1977).

Limited evidence (Rinkevich and Loya 1983a; Hunter 1985; Willis and Ayre 1985) suggests that allorecognition

in corals is genetically based. However, there is no evidence as to the nature of coral histocompatibility, in terms of the number of alleles or loci, or the extent of modification by the environment (Neigel and Avise 1983; Grosberg 1988).

It is generally agreed that the best method to determine the genetic basis of allorecognition is through breeding or inheritance studies (Grosberg 1988). However, at present the technology to raise lines of reef-building corals in controlled laboratory conditions or in the field is not available, because the generation time may be several years at least. Therefore, an alternative approach, albeit less promising, is to examine allorecognition responses within and between different outbred colonies in a natural coral population.

Histocompatibility in Stylophora pistillata

Stylophora pistillata is one of the dominant reef-building scleractinians in shallow habitats on Indo-Pacific coral reefs (Loya 1976; Resing and Ayre 1985). Studies on allorecognition responses of this species indicate the existence of colony specificity: while isografts (within-colony grafts) are always accepted, complete fusion between neighboring colonies (allografts) has never been observed in grafting assays in both eastern Australian (Resing and Ayre 1985; > 70 allografts) and Red Sea populations (Rinkevich and Loya 1983a; > 300 allografts). Several levels of intensity in allotypic responses have been documented, ranging from unilateral cytotoxicity (rejection) to the formation of skeletal barriers (sutures) and eventual overgrowth of one genotype by another (Rinkevich and Loya 1983a). Some effector mechanisms for transplant incompatibility in *S. pistillata* include the use of nematocysts which cause localized tissue destruction (rejection, Rinkevich and Loya 1993a) and the production of caustic enzymes that dissolve skeleton at the contact interface (Müller et al. 1984).

Allogeneic responses of *Stylophora pistillata* correlate partially with color forms (in which colonies of purple morphs are usually dominant over yellow morphs and competitively exclude them) and with the relative body size of interacting colonies (Rinkevich and Loya 1983a). However, a genetically based network of allogeneic interactions may also occur, in which, instead of cytotoxicity, some allotypic pairs form sectorial chimeras, with or without unilateral overgrowth (Rinkevich and Weissman 1987). A study with ¹⁴C labeled allografts revealed that one member of the chimera may parasitize the energy resources of the other (Rinkevich and Loya 1983b), with consequent negative effects on both partners in terms of somatic growth and sexual reproduction (Rinkevich and Loya 1985).

Here we present a two-year field study which indicates that allorecognition in the branching coral *S. pistillata* is characterized by self/nonself discrimination of considerable inter-colony diversity, and includes four distinct allogeneic reactions; rejection, nonfusion, suture formation and tissue overgrowth. Cytotoxicity in some cases is not apparent until 9 months after initial contact, and at 18–22 months reversals in overgrowth directions may occur. Based on these results, we discuss the terminology used for “fusion”

processes in corals, and the methodological artifacts associated with attempts to use short-term histocompatibility assays as a tool for distinguishing among coral genotypes.

Methods

All experiments were conducted with *Stylophora pistillata* (Esper) colonies, at 5–7 m depth on the coral reef adjacent to the Steinitz Marine Biology Laboratory (SMBL), Eilat, Israel. This species is one of the most abundant corals in the northern Gulf of Eilat (Loya 1976). It occurs in a variety of color forms that exhibit the same morphology, growth rate and sexual reproductive pattern, and thus are thought to comprise a single species (Rinkevich and Loya 1985). These color forms, which range from pale yellow to brownish pink and dark purple, cluster into two major morphs: the yellow morph (which includes all pale, yellow, to brown forms) and the purple morph (Rinkevich and Loya 1983a, b).

For the assays listed later, we used 11 mature *S. pistillata* colonies. Five large (> 10 cm diameter) colonies, two yellow (colonies B, D) and three purple (colonies C, E, F), were marked within a 20 × 20 m area near the SMBL. In addition, four large colonies, three yellow (colonies K, L, P) and one purple (colony M), were collected from a 20 × 20 m area at a reef 1 km north of the SMBL. They were detached carefully from the reef with a hammer and chisel, and transported in seawater to the SMBL site. Branches 3–5 cm in length were carefully broken from each colony with sidecutting pliers, and secured by plastic clothespins attached to concrete tiles, so that each branch tip was positioned < 1 mm from the tip of its partner. Tissue graft assays were set up among these 9 colonies, in all 36 possible pairwise combinations (all replicates of the combination DP were accidentally destroyed), with 3–7 replicates of each combination (144 successful pairs). Branches of two additional purple colonies from the SMBL site (colonies A, G) were further assayed in 11 more pairwise combinations with colonies B, C, D, E, and F (37 successful pairs). Combinations BC, CE, DM, KM, LP (see Table 1) were interrupted before overgrowth directionality could be established. Combinations AK, AL, AM, AP, DP, GK, GL, GM, GP were destroyed by storms or human activities, or were not performed because of the loss of the original colonies prior to the establishment of these assays. Two replicate pairs of control isogenic contacts were set up between branches within each of the 11 genotypes ($n = 22$ pairs). In addition, ten whole small colonies (< 5 cm diameter) were removed from the substratum at the SMBL site and matched in five interacting pairs on the tiles, < 1 mm apart within each pair. These pairs of whole colonies served as comparison assays for the time scale and types of interactions found in the branch pair assays.

The outcomes of all tissue contacts were observed weekly for the first two months, then each month for up to two years. In cases of unilateral tissue rejection, observations were discontinued after 8 months, at which time the final outcome was clear and irreversible.

Results

Five main outcomes of tissue contacts were recorded: (1) *rejection* (Fig. 1a): unilateral tissue destruction extending > 1 mm from the contact zone. This area of exposed skeleton was eventually covered by bacterial/algal turf, and appeared as a brown/black area in color; (2) *complete fusion*: characterized as continuous tissue and skeleton across the contact area, branches inseparable; (3) *nonfusion*: initial appearance of fusion, with almost continuous skeletal plates separated by only a microscopic gap, branches separable by slight force; developing later into skeletal projections called (4) *sutures* (Fig. 1b, c), which extended

Table 1. Patterns of alloreactivity in *Stylophora pistillata* and time scales (in months) for histocompatibility outcomes among 11 colonies in 46 pairwise colony combinations. See text for definition of outcomes

Colony combination	Time range (in months) to start of outcome (no. of replicates in parentheses)			
	Rejection	Nonfusion	Suture	Overgrowth
AB	–	4 (7)	5–8 (7)	A > B, 8–14 (6)
AC	–	2–3 (3)	6 (2)	A > C, 10 (1)
AD	–	3 (2)	6 (2)	A > D, 7 (2)
AE	–	2 (3)	7–9 (3)	A > E, 23 (3)
AF	–	2–3 (3)	6 (3)	A > F, 12 (3)
AG	–	2–4 (3)	6 (3)	G > A, 12 (3)
BC	–	2 (3)	9 (1)	^a
BD	–	3 (3)	6–7 (2)	D > B, 13 (1)
BE	–	2 (3)	6 (3)	B > E, 15 (1)
BF	–	2 (3)	6 (3)	F > B, 7 (3); B > F, 20–22 (3)
BG	–	2 (3)	3 (1)	B > G, 12 (1)
BK	K > B, 6–7 (3)	–	–	–
BL	L > B, 2 (3)	–	–	–
BM	–	3 (3)	6–7 (3)	B > M, 7 (2)
BP	B > P, 0.8 (3)	–	–	–
CD	–	4–5 (5)	5–8 (4)	C > D, 8–12 (4)
CE	–	3–4 (5)	4–7 (5)	^a
CF	–	3 (6)	4–6 (5)	C > F, 7–15 (5)
CG	–	2 (3)	3 (3)	G > C, 7–9 (3)
CK	C > K, 0.8–1 (6)	–	–	–
CL	C > L, 0.2–1.5 (6)	–	–	–
CM	–	3 (6)	7 (6)	M > C, 14–15 (4); C > M, 18–22 (4)
CP	C > P, 0.2–1.2 (6)	–	–	–
DE	–	2 (3)	6–7 (3)	E > D, 14–16 (2)
DF	–	3 (3)	4–5 (3)	F > D, 7–9 (3)
DG	–	2 (3)	3–6 (3)	G > D, 7–9 (3)
DK	K > D, 1–2 (3)	–	–	–
DL	D > L, 2–4 (2)	–	–	–
DM	–	2–4 (5)	4–6 (5)	^a
EF	–	4 (4)	5 (4)	E > F, 8–14 (3)
EG	–	2–3 (3)	3–6 (3)	G > E, 6–9 (3)
EK	E > K, 0.8–1.5 (6)	–	–	–
EL	E > L, 0.5–0.8 (6)	–	–	–
EM	–	3 (5)	4–7 (5)	E > M, 11 (1)
EP	E > P, 0.8 (3)	–	–	–
FG	–	2–4 (3)	7 (3)	G > F, 8 (1)
FK	F > K, 1.2 (5)	–	–	–
FL	F > L, 1.2 (5)	–	–	–
FM	–	3–4 (5)	4–8 (3)	M > F, 11–16 (2)
FP	F > P, 0.8 (3)	–	–	–
KL	–	3–4 (4)	6–8 (4)	L > K, 10–14 (2)
KM	M > K, 0.8–1.3 (4)	–	–	–
KP	–	3–7 (3)	6–9 (3)	^a
LM	M > L, 0.8 (6)	–	–	–
LP	–	3–6 (2)	6–9 (2)	^a
MP	M > P, 0.8 (3)	–	–	–

^a Assays that were accidentally destroyed (by storms or divers) before overgrowth directionality could be established

vertically from the surface of the branches, also termed filling (Potts 1976), cementation (Hildemann et al. 1975), border lines (Rinkevich and Loya 1983a), interdigitated surfaces (Chornesky 1991) skeletal ridges (Hidaka and Yamazato 1984), calcareous plugs (Müller et al. 1984), calluses (Hunter 1985), and lips of skeleton (Resing and Ayre 1985). This outcome was usually followed by (5) *overgrowth* (Fig. 1d) of one colony over the other (details in Rinkevich and Loya 1983a).

All within-colony (isogenic) grafts ($n = 22$) resulted in complete fusion. This was first observed 1–4 months from the start of contact, and persisted indefinitely (recorded up

to 2 years later). During this period, fused branches became so continuous that it was impossible to distinguish the original border between them. Contrary to isografts, no complete fusion was recorded in any of the 181 allografts assayed between the 11 colonies.

The nine colonies tested for all combinations fell into three distinct groups according to their color morphs and allogeneic outcome (Fig. 2). The two additional purple colonies A and G were not included in either groups 1 or 2 or clustered as an additional separate group, since we failed to establish their combinations against group 3 colonies (K, L and P). With all other colonies of groups 1

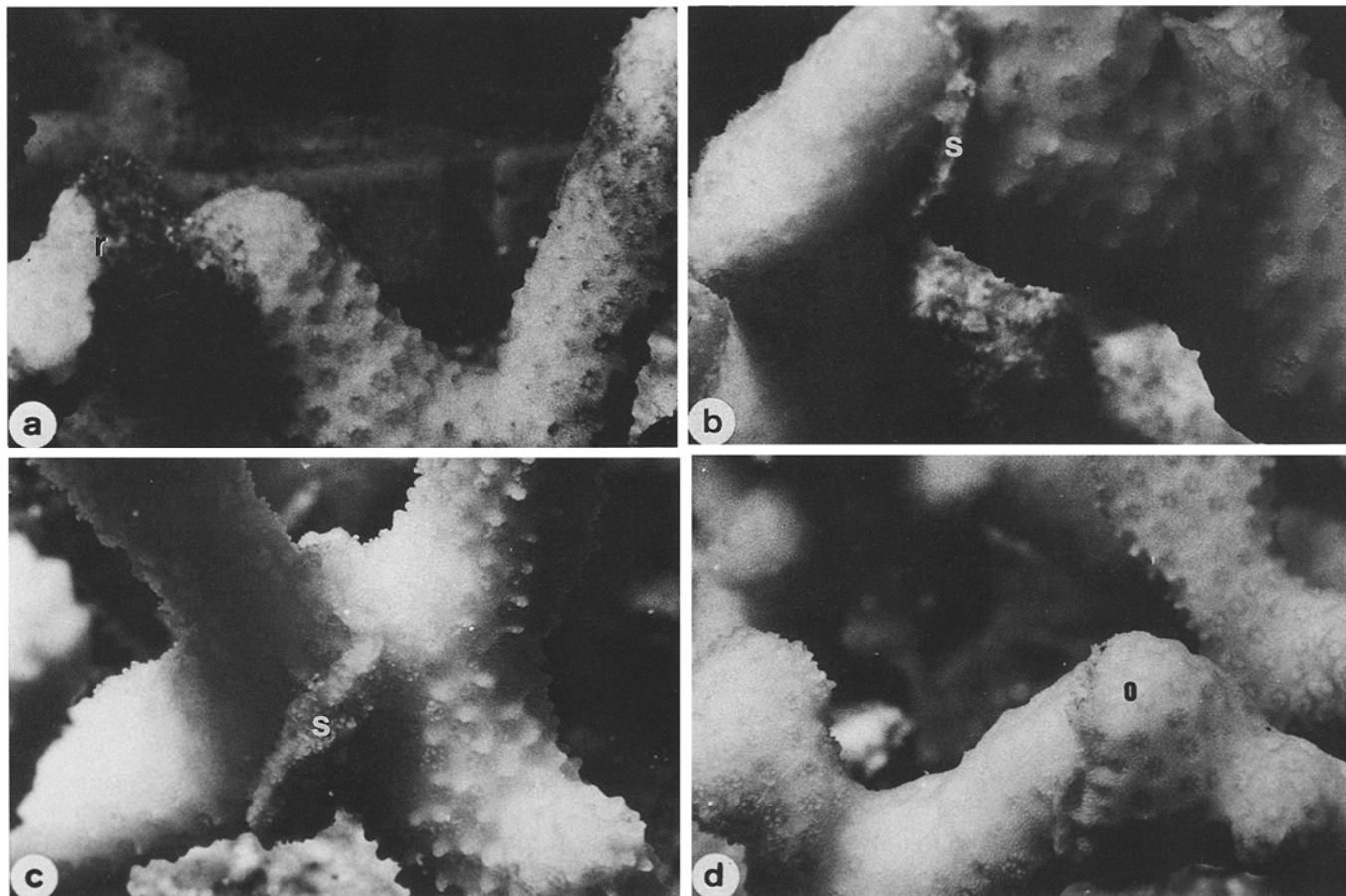

Fig. 1. Alloimmune reactions of the scleractinian coral *Stylophora pistillata*. **a** Unilateral rejection between branches from different colonies. The left colony is rejected by the right colony. The rejected area is covered by turf algae, bacteria and other microorganisms;

b nonfusion and suture formation between branches from different colonies; **c** a serpentine suture between allogeneic branches; **d** overgrowth of the right colony over the left one. Symbols: *o*, overgrowth; *r*, rejected tissue area; *s*, suture

and 2, colonies A and G responded with nonfusions (Fig. 2, Table 1). All four colonies in group 1 (purple), in all replicates, engaged in nonfusion with the two colonies of group 2 (yellow) and unilaterally rejected (Fig. 1a) the three colonies of group 3 (yellow). All combinations of group 2 versus group 3 (all yellow) resulted in rejections, with a direction specific to any given pair of colonies. All colonies within each group exhibited nonfusion (Fig. 1b,c) with each other (Fig. 2).

Unilateral rejections occurred in 17 (36.9%) of the 46 combinations (73 out of 144 assays), which included 12 purple versus yellow and 5 yellow versus yellow combinations (Table 1; Fig. 2). When purple (group 1) and yellow (group 3) colonies were assayed, purple always rejected yellow (Fig. 2). Rejections between colonies of unlike color morph proceeded rapidly, within a period of less than 2 months in all assays of all colony combinations (Table 1). The direction and time scale of rejections between the two groups of yellow colonies (groups 2 and 3; Fig. 2) varied with each colony combination. For example, while colony K of group 3 rejected both D and B colonies of group 2, colony D rejected colony L of group 3 (Table 1; Fig. 2). The time scale of yellow-yellow rejec-

tions also varied significantly between pairs of colonies (Kruskal-Wallis test, $H = 12.49$, $P < 0.05$, Fig. 2, Table 1). All rapid rejections (initiated at 1 month to < 4 months) occurred without prior nonfusion between contacts. In contrast, the delayed rejection between colonies K and B (at 6–7 months) began as a state of nonfusion. At 4 months, abundant mucus became evident along the contact area in the 3 studied pairs, followed by unilateral rejection of B by K, 2–3 months later.

Nonfusion (Fig. 1b,c) occurred between all combinations within each group (Fig. 2), and between all colony combinations of groups 1 and 2 [18 (51.4%) of the 35 successful pairwise colony combinations; Fig. 2, Table 1]. After an initial period (0–3 months) of no reaction between contacting pairs, nonfusion began at 2 and continued to 7 months, then proceeded to suture formation (starting at 3–9 months), and then to either walled suture formation or overgrowth (beginning at 7–24 months, Table 1). Twelve months after initial contact, some sutures (Fig. 1c) had grown in height up to 4 mm above branch surfaces (walled sutures), and many overgrowths (Fig. 1d) extended up to 2 cm over the branches of “subordinate” colonies.

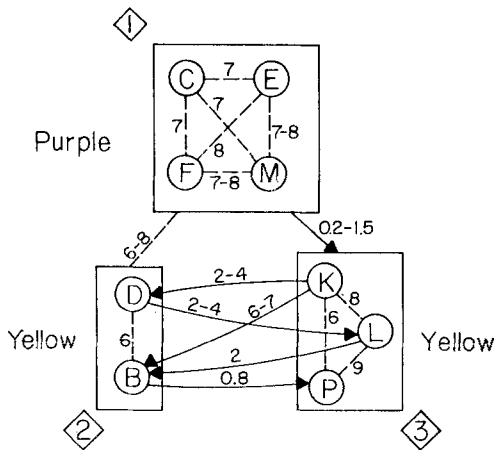

Fig. 2. Network of alloimmune reactions among 9 colonies of the scleractinian reef coral *Stylophora pistillata*, each represented by a circled letter. Colonies are assigned to 3 histocompatibility groups according to alloreactivity and color morph. The members of each group are enclosed in a box, designated by a number in a diamond at the outer corner of the box. Connections between boxes indicate that the same reaction occurs between all replicates of the colonies in one group and all those in the other. Numbers adjacent to the connections indicate the time intervals (in months) from the start of contact to the initiation of the reaction, either rejection or nonfusion. A → B indicates that A unilaterally rejects B. A --- B indicates that A initially exhibited nonfusion with B, then formed a suture along the contact region. Details in text

Beginning at 7 months, overgrowths of one colony over the other were observed among pairs in groups 1 and 2 that had formed sutures, and in some combinations with the two additional purple colonies (colonies A and G) from the SMBL site (Fig. 3). In many overgrowths, small areas of cytotoxicity developed on the tissue of the "inferior" partner (the overgrown genotype). These small lesions were overgrown by the "dominant" partner or partly healed. They did not develop into the large necrotic areas characteristic of rapid rejections.

The results indicate a network of overgrowths (which include linear hierarchies, circular interactions, as well as reversals, see later), in which the purple colonies G and A emerge as relative dominants, since each overgrew other colonies in 5/6 combinations (Fig. 3). The yellow colony D and the purple colony F are relative subordinates, since they overgrew in only 1/6 and 1/7 pairwise combinations, respectively. The other four colonies (B, E, C, M) interact as intermediates in a complex network (winners in 3/6, 3/6, 2/5 and 1/4 combinations, respectively; Fig. 3). Among the intermediate colonies, two sets of reversals (*sensu* Chornesky 1989) in overgrowth direction occurred at 18–22 months after initial contact. In colony combination FB (purple versus yellow, respectively), F overgrew B by 2–5 mm of skeleton at 7 months in all three branch pairs. Then at 16–19 months, they overgrew each other in interdigitating fingers of skeleton, each 2–5 mm long, in all three pairs. This mutual overgrowth slowly became unidirectional again at 20–22 months as B overgrew F by 5–10 mm, in all three pair replicates. A second reversal occurred in combination CM (both purples), in which M initially overgrew C at 14–15 months by 2–4 mm in four pairs. Then C overgrew M at 18–22 months by 2–5 mm in

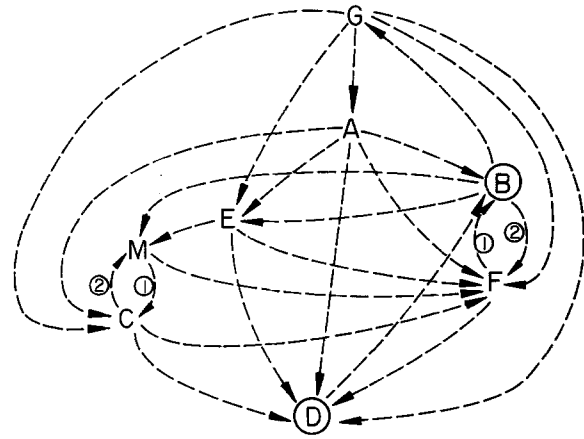

Fig. 3. A nontransitive hierarchy among 8 *Stylophora pistillata* colonies at 2 years after initiation of contact, following initial nonfusion and suture formation. Colonies B and D (in circles) are yellow, the rest are purple. Arrows indicate the direction of overgrowth. Circled numbers represent the sequence of overgrowth reversals between colony pairs. Combinations that were not established or that were evidently destroyed are listed in the materials and methods

three remaining pairs. The interaction appeared to slow down at 24 months when a suture border was observed between the colonies in two pairs, with no obvious overgrowth in either direction. The directionality of these overgrowth reversals is indicated by circled numbers in Fig. 3.

While seven of the colonies exhibited a linear hierarchy of overgrowth interactions (where colony G > A > E > M = C > F > D; Fig. 3), yellow colony B emerged as the one which changed this hierarchy to a nontransitive (= circular) hierarchy. This colony overgrew the dominant G and two other purple colonies (E and M) but was overgrown by both the subordinate yellow D and the dominant A (Fig. 3). Additionally, it participated in one of the two reversals observed during the two years of interactions (with colony F, Fig. 3).

All pairwise colony combinations exhibited the same direction of unilateral rejection ($n = 73$) or overgrowth ($n = 62$) (Figs. 2 and 3, Table 1). Purple colonies in most cases dominated yellow ones: group 1 purples rejected group 3 yellows in all 12 colony combinations and all assays ($n = 59$, Table 1). In addition, purple colonies overgrew the yellow colonies B and D in 66.7% of the nine colony combinations ($n = 24$ pairs, excluding pair BF).

The outcome and time scale of interactions between the detached branch ramets of large colonies did not differ from those between small whole colonies: the whole colony assays ($n = 5$ pairs) initiated nonfusion reactions at 2–5 months, suture formation at 4–7 months, and overgrowths at 8–24 months following initial contacts.

Discussion

Patterns of alloreactivity in Stylophora pistillata

The branching coral *Stylophora pistillata* possesses a highly polymorphic and complex allorecognition system. As a result, interacting genotypes rarely if ever completely

fuse. In the > 400 allogeneic combinations of *S. pistillata* monitored to date (Rinkevich and Loya 1983a; Resing and Ayre 1985; Fig. 2), complete fusion of tissues has not been observed, even between neighboring colonies. Each colony, therefore, appears to possess a unique histocompatibility identity, recognizable as nonself to most, if not all, other conspecific colonies.

Although fusion was not recorded in allogeneic encounters, the incompatible responses vary in accordance with the specific combination of the colonies in contact; the same colony may either reject, be rejected by, or engage in nonfusion with (and subsequently overgrow or be overgrown by) different conspecifics. For example, colony D rejected colony L, was rejected by colony K, was overgrown by five different colonies (A, C, E, F, G), and overgrew colony B (Figs. 2, 3). These outcomes are reproducible and consistent among all replicates of any given colony combination, in both direction and time scale (Table 1). Thus, it appears that alloreactivity in *S. pistillata* is under specific genetic control.

As demonstrated previously (Rinkevich and Loya 1983a) and confirmed in the present study, the intransitive hierarchy of outcomes is at least partly associated with the colony color: in most cases of purple versus yellow combinations, purple colonies either reject unilaterally or overgrow yellow ones. Similar linkage of alloreactivity to color pattern has been observed in allograft assays of the coral *Pavona cactus* (Willis and Ayre 1985) and the sea anemone *Actinia equina* (Brace and Reynolds 1989).

We clustered the tested colonies into three alloreactivity groups, depending on the outcome of contacts. Within each group, all corals engaged in nonfusion; between groups, corals exhibited nonfusion or rejection in a group-specific manner. Within this scheme, two cases of reversals in the direction of overgrowth developed, with reproducibility in both direction and time scale. Therefore, being "subordinate" or "dominant" in these reversals is clearly time-dependent, probably resulting from nongenetic factors and controlled by environmental and/or physiological parameters. Our results also indicate that historecognition in *S. pistillata* is expressed as at least three major morphologically distinct phenomena: fusion (only between isografts), rejection, and nonfusion (only between allografts). It is also possible to characterize additional allogeneic responses within the framework of the nonfusion reaction, such as unilateral overgrowth (Figs. 1d, 3), walled suture formation (Fig. 1c), and reversal.

The results of the present study may serve as first steps in the formulation of a genetic basis for allorecognition in *S. pistillata*. The ability of *Stylophora* colonies to respond selectively and reproducibly to different types of allogeneic genotypes (rejecting, being rejected by, being overgrown by, overgrowing) may suggest that this species distinguishes self from nonself by detecting the presence or absence of attributes that define nonself (*sensu* Neigel 1988). According to this idea, each specific genotype would acquire colony-specific nonself receptors. This would generate high polymorphism of nonself elements and result in complex allorecognition effector mechanisms, as revealed in this and earlier studies (Rinkevich and Loya 1983a, b, 1985). If this concept is correct, the capacity for self-nonself recognition in *Stylophora* cannot reside in a

single polymorphic gene locus but is probably controlled by several discrete haplotypes at two or more loci. This is further elucidated by the phenomena of delayed responses, nontransitive hierarchies and reversals in overgrowth directionality.

Terminology used and time scale for alloreactivity

Important aspects of the present study are involved with the time scale, terminology, and qualitative criteria used to classify coral graft reactions as fused or not fused. For example, do outcomes such as filling (Potts 1976), cementation (Hildemann et al. 1975), calcareous plugs (Müller et al. 1984), interdigitated surfaces (Chornesky 1991), and border lines (Rinkevich and Loya 1983a) indicate "fusion" or should they be grouped as "nonfusion responses"? We suggest that these various reactions, and others which may be discovered in future studies, should be grouped together under the title of "nonfusion", or should be regarded as consequent outcomes to the histoincompatibility state of "nonfusion". These represent one of the two recognition states of "nonself", the other being "rejection" which is characterized by extensive cytotoxicity and tissue necrosis at the contact interface. All of these responses may reflect the expression of a variety of effector mechanisms of antagonistic reactions, following a process of nonself discrimination. In contrast, the term "fusion" has been applied on the one hand to reactions between syngeneic tissues, and on the other hand to the formation of both cytotoxic and sectorial chimeras (Rinkevich and Weissman 1987). Additionally, some grafts between distinct individuals of the same species have been classified as complete fusions after only brief observation periods of < 5 months (Bak and Criens 1982; Jokiel et al. 1983; Heyward and Collins 1985; Heyward and Stoddart 1985; Resing and Ayre 1985). In the present study, clear sutures did not appear in some "apparently fused" pairs until 7–9 months after initial contact (Table 1). Short time periods therefore are clearly inadequate to detect possible resegregation of allografted tissues following initial nonfusions in scleractinian corals.

Several implications arise from this conclusion. The extent of cnidarian clones may be less than previously estimated using short-term grafting assays, because non-clonemate colonies may exhibit an initial appearance of fusion. Some allografts have been labeled as "non-scorable" because the outcomes were ambiguous, suggesting that the distinction between fusion and nonfusion in coral allografts is sometimes unclear (Resing and Ayre 1985; Willis and Ayre 1985). Even results drawn from grafts observed over longer periods of 6–10 months (Bothwell 1981; Neigel and Avise 1983; Willis and Ayre 1985) may be unreliable, because coral skeletal growth rates in some species, and thus the rate of barrier formation following initial fusion, may be slow or variable, in comparison with the relatively nonvariable growth pattern and rate of *Stylophora pistillata* (see Loya 1976). In the rapidly growing coral *Acropora palifera*, more than half of observed allograft outcomes changed during the 12 months following initiation of contact (Potts 1976). On the other hand, several years of observation may be required to determine final allograft outcomes in slow-growing species.

Thus, some corals may display a greater variety of allorecognition responses than the simple dichotomy of fusion and one type of massive rejection reported for certain species (Hildemann et al. 1977; Jokiel et al. 1983; Neigel and Avise 1983; Heyward and Stoddart 1985; Resing and Ayre 1985), such as the various "nonfusion" responses described here. Future observations on coral histocompatibility must take into account a possible gradation of alloresponses and the delayed appearance of phenomena at the morphological level. In order to be reliable, data collection must extend over adequate time scales and include sufficient replication to detect both within and between-colony variability in outcomes following allorecognition.

Acknowledgements. We thank B. Baumgratz, K. Joe, T. Liberman and J. Sutherland for diving assistance, H. Bernard for drawing Figs. 2 and 3, and the staff of the Steinitz Marine Biology Laboratory for their hospitality and technical support. Funds were provided by a postdoctoral fellowship at the Inter-university Institute of Eilat (N.C.F.), a Research Career Development Award from the ICRF-US (B.R.), and a grant from the GIF, German-Israeli Foundation for Scientific Research and Development (B.R.).

References

- Bak RPM, Criens SR (1982) Experimental fusion in Atlantic *Acropora* (Scleractinia). *Mar Biol Lett* 3:67–72
- Bancroft FW (1903) Variation and fusion of colonies in compound ascidians. *Proc Calif Acad Sci* 3:137–186
- Beale G (1990) Self and nonself recognition in the ciliate protozoan *Euplotes*. *Trend Genet* 6:137–139
- Bothwell AM (1981) Fragmentation, a means of asexual reproduction and dispersal in the coral genus *Acropora* (Scleractinia Asterozoa) – a preliminary report. *Proc 4th Int Coral Reef Symp* 2:137–144
- Brace RC, Reynolds HA (1989) Relative intraspecific aggressiveness of pedal disc colour phenotypes of the beadlet anemone, *Actinia equina*. *J Mar Biol Ass UK* 69:273–278
- Burnet FM (1971) Self-recognition in colonial marine forms and flowering plants in relation to the evolution of immunity. *Nature* 232:230–235
- Chornesky EA (1989) Repeated reversals during spatial competition between corals. *Ecology* 70:843–855
- Chornesky EA (1991) The ties that bind: inter-clonal cooperation may help a fragile coral dominate shallow high-energy reefs. *Mar Biol* 109:41–51
- Fuke MT, Nakamura I (1985) Pattern of cellular alloreactivity of the solitary ascidian, *Halocynthia roretzi*, in relation to genetic control. *Biol Bull* 169:631–637
- Grosberg RK (1988) The evolution of allorecognition specificity in clonal invertebrates. *Q Rev Biol* 63:377–412
- Grosberg RK, Quinn JF (1989) The evolution of selective aggression conditioned on allorecognition specificity. *Evolution* 43:503–515
- Hauenschild C (1954) Genetische und entwicklungshistologische Untersuchungen über Intersexualität und Gewebeverträglichkeit bei *Hydractinia echinata* Flem. *Wilhelm Roux Arch.* 147:1–141
- Heyward AJ, Collins JD (1985) Fragmentation in *Montipora ramosa*: the genet and ramet concept applied to a reef coral. *Coral Reefs* 4:35–40
- Heyward AJ, Stoddart JA (1985) Genetic structure of two species of *Montipora* on a patch reef: conflicting results from electrophoresis and histocompatibility. *Mar Biol* 85:117–121
- Hidaka M (1985) Tissue compatibility between colonies and newly settled larvae of *Pocillopora damicornis*. *Coral Reefs* 4:111–116
- Hidaka M, Yamazato K (1984) Intraspecific interactions in a scleractinian coral, *Galaxea fascicularis*: induced formation of sweeper tentacles. *Coral Reefs* 3:77–85
- Hildemann WH, Linthicum DS, Vann DC (1975) Transplantation and immunocompatibility reactions among reef-building corals. *Immunogenetics* 2:269–284
- Hildemann WH, Raison RL, Cheung G, Hull CJ, Akaka L, Okamoto J (1977) Immunological specificity and memory in a scleractinian coral. *Nature* 270:219–223
- Hildemann WH, Johnston IS, Jokiel PL (1979) Immunocompetence in the lowest metazoan phylum. Transplantation immunity in sponges. *Science* 204:420–422
- Hildemann WH, Bigger CH, Johnston IS, Jokiel PL (1980) Characteristics of transplantation immunity in the sponge *Callispongia diffusa*. *Transplantation* 30:362–367
- Hunter CL (1985) Assessment of clonal diversity and population structure of *Porites compressa* (Cnidaria, Scleractinia). *Proc 5th Int Coral Reef Congr* 6:69–74
- Jokiel PL, Hildemann WH, Bigger CH (1983) Clonal population structure of two sympatric species of the reef coral *Montipora*. *Bull Mar Sci* 33:181–187
- Kingsley EA, Briscoe DA, Raftos DA (1989) Correlation of histocompatibility reactions with fusion between conspecifics in the solitary urochordate *Styela plicata*. *Biol Bull* 176:282–289
- Loya Y (1976) The Red Sea coral *Stylophora pistillata* is an r strategist. *Nature* 259:478–480
- Müller WEG, Müller I, Zahn RK, Maidhof A (1984) Intraspecific recognition system in scleractinian corals: morphological and cytochemical description of the autolysis mechanism. *J Histochem Cytochem* 32:285–288
- Neigel JE (1988) Recognition of self or nonself. Theoretical implications and an empirical test. In: Grosberg RK, Hedgecock D, Nelson K (eds) *Invertebrate historecognition*. Plenum, NY, pp 127–142
- Neigel JE, Avise JC (1983) Clonal diversity and population structure in a reef-building coral, *Acropora cervicornis*: self-recognition analysis and demographic interpretation. *Evolution* 37:437–453
- Oka H, Watanabe H (1960) Problems of colony-specificity in compound ascidians. *Bull Biol Stn Asamushi* 10:153–155
- Potts DC (1976) Growth interactions among morphological variants of the coral *Acropora palifera*. In: Mackie GO (ed), *Coelenterate ecology and behavior*. Plenum, NY, pp 79–88
- Raftos DA, Briscoe DA (1990) Genetic basis of histocompatibility in the solitary urochordate *Styela plicata*. *J Heredity* 81:96–100
- Resing JM, Ayre DJ (1985) The usefulness of the tissue grafting bioassay as an indicator of clonal identity in scleractinian corals (Great Barrier Reef-Australia). *Proc 5th Int Coral Reef Congr* 6:75–81
- Rinkevich B, Loya Y (1983a) Intraspecific competitive networks in the Red Sea coral *Stylophora pistillata*. *Coral Reefs* 1:161–172
- Rinkevich B, Loya Y (1983b) Oriented translocation of energy in grafted reef corals. *Coral Reefs* 1:243–247
- Rinkevich B, Loya Y (1985) Intraspecific competition in a reef coral: effects on growth and reproduction. *Oecologia* 66:100–105
- Rinkevich B, Weissman IL (1987) Chimeras in colonial invertebrates: a synergistic symbiosis or somatic and germ-cell parasitism? *Symbiosis* 4:117–134
- Sabbadin A (1962) Le basi genetiche della capacità di diffusione fra colonie in *Bostryllus schlosseri*. *Atti Accad Naz Lincei Rend* 32:1031–1035
- Scofield VL, Schlumpberger JL, West LA, Weissman IL (1982) Protochordate allorecognition is controlled by an MHC-like gene system. *Nature* 295:499–502
- Willis BL, Ayre DJ (1985) Asexual reproduction and genetic determination of growth form in the coral *Pavona cactus*: biochemical, genetic and immunogenic evidence. *Oecologia* 65:516–525