

The Free Surface on a Liquid between Cylinders Rotating at Different Speeds

Part I

DANIEL D. JOSEPH & ROGER L. FOSDICK

Contents*

1. Introduction	321
2. Statement of the Problem	325
Chapter I. A Domain Perturbation Theory	330
3. Prescribed Domain Deformations: Generalization of Hadamard's Formula	330
4. Free Surface Domain Deformations: The Shape of the Free Surface on a Newtonian Liquid at Lowest Order	333
5. Generation of Secondary Motions	339
6. Secondary Motion When the Gap Is Small	342
Chapter II. The Free Surface on a Simple Fluid	352
7. Characterization of the Problem for Non-Newtonian Fluids	352
8. First Order Solution	354
9. Second Order Solution: The Free Surface Shape at Lowest Significant Order.	357
10. Third Order Solution	362
11. The Problem at Fourth Order	364
Chapter III. Surface Tension Effects	368
12. Effects of Surface Tension on the Shape of the Free Surface	368
13. Perturbation from the State of Rigid Rotation	372
14. Surface Tension Boundary Layers	376

1. Introduction

When a liquid in a vessel rotates as a rigid body, the free surface on top of the liquid is shaped by the requirements of a balance of forces arising from centripetal accelerations, gravity, and surface tension. In the absence of relative internal motion, the configuration of such a surface is independent of the way in which the fluid responds to stresses. For example, the free surface of a fluid without surface tension has a paraboloidal shape.

* Part I of this paper gives the basic theory for the free surface problem in general terms. In Part II we develop further those parts of the theory which express our most recent view of the principal balance of forces which shape the free surface on a simple fluid. Our most recent view evolves as a direct consequence of the experiments which we initiated in collaboration with G. S. BEAVERS and which are reported in Part II. We are persuaded that our theory of climbing, together with the experiments reported in Part II, form the basis for a standard laboratory test to determine certain characterizing constants for non-Newtonian fluids. The considerable degree to which this belief can be supported by results already obtained is put into evidence in Part II. Apart from this note, and a note at the end of Part I, we have not incorporated into Part I what we learned from our experiments; this part stands as originally written.

The situation is different when the liquid is in relative internal motion. In this case there will exist a stress field which also affects the shape of the free surface. Thus, the actual shape which a surface assumes in the presence of a relative internal motion is sensitive to the manner in which different liquids respond.

One of the most simple situations of relative internal motion which also involves a free surface is that of a liquid filling the semi-infinite space between two concentric cylinders which rotate at different steady speeds. When the liquid is non-Newtonian this situation is associated with the phenomenon of climbing; this phenomenon is one striking manifestation of the normal stress effect. Here, the shearing of the liquid induces stresses along and perpendicular to cylinder generators on planes which are perpendicular to the planes of primary shear. These normal stresses are larger where the primary shear is greatest; because of the presence of a free surface, in the regions of greatest shear the liquid is forced up along the cylinder generators.

Two previous studies of the climbing problem merit mention. * SERRIN's [13] analysis of an incompressible Reiner-Rivlin fluid relies on some simplifying assumptions; the velocity field is assumed to be independent of the coordinate along the axis of the cylinder, non-equilibrated shear stresses at the free surface are ignored, and the two material functions of the Reiner-Rivlin theory are replaced by constants. However, SERRIN does achieve a definite conclusion which is contained in our perturbation result at second order and which can be recovered when our result is specialized to the case treated by him (see Section 9). A second more general study, which apparently is due in principle to ERICKSEN [3], has been given by COLEMAN, MARKOVITZ, & NOLL [1] and TRUESDELL & NOLL [17] for a general simple fluid; in these studies the value of the normal stress along the axis is computed from the Couette flow field in an infinite cylinder. The direction of climbing is determined in a qualitative sense by replacing the true pressure distribution on a plane $z = \text{const.}$ with a constant pressure as on a true free surface. The overthrust of the normal stress on the fictitious plane of constant pressure is the basis for the approximate computation of the direction of climbing. Of course, since gravity and surface tension are not considered, a discussion of the mechanisms which shape the free surface are outside of the scope of these qualitative studies.

In the present work, we develop a systematic construction in series for the shape of the free surface above a simple fluid as well as for the induced secondary motion. Our best results are obtained from the perturbation of a state of rest. Here the perturbation parameter is essentially the prescribed angular velocity Ω of one of the cylinders. The perturbation analysis would be straightforward were it not for the fact that the free surface, and thus the fluid domain, depend on Ω .

Our analysis is based on the domain perturbation method [8] and the improved method [9] of JOSEPH. The general procedure used in [8] involves solving a boundary value problem in a given region of space by mapping it onto a standard region of simple shape. The mapped problem is then expanded in a power series in the parameter characterizing the domain deformation. The perturbation problems which arise in the expansion are then solved successively in the standard region, and the resulting series is mapped back into the original domain. The method of

* See our *Note Added in Proof* at the end, p. 380.

[8] was based upon having an explicit representation of the domain mapping (*i. e.*, the deformation) for all boundary *and* interior points of the domain. The improved method [9], which we further develop and apply in this paper, obviates the need for a definite characterization of the domain mapping function at interior points and makes essential use only of the deformation of points on the boundary. When this new method is applied to problems where the domain deformation is prescribed, as, for example, those treated in [8] and [10], it leads (as in [9] and here in Section 3) to a considerable simplification and operational convenience. The extension of the domain perturbation method to our problem, in which the shape of the deformed domain is unknown, constitutes a principal mathematical contribution of the present work.

The other contributions of the paper are most easily described in a preliminary survey of its organization. The table of contents gives an overview of this organization. In Section 2, we give a general formulation of our problem. In Sections 4 through 6, we shall develop the domain perturbation method and apply it to the problem of the free surface on the top of a Newtonian liquid in the absence of surface tension. We are not yet acclimated to the idea that this very classical problem seems so far to have escaped analysis. On the chance that this is in fact true and because the methods are more neatly exposed in this widely familiar context than in the intriguing simple fluid problem, we have developed in Sections 4, 5, and 6 a full analysis of the classical problem. The analysis is terminated just after the point where a secondary motion first appears.

The perturbation of the rest state is constructed as a series in powers of Ω , and there is a neat ordering of effects with each of the powers. At zeroth order there is a flat surface with atmospheric pressure above and hydrostatic pressure below. At order Ω , an azimuthal field appears without change of pressure. There is no deviation from a flat free surface at this order. At order Ω^2 , there is no velocity correction; but the first order azimuthal velocity field induces a pressure change through central forces. This pressure change produces the first deviation of the free surface from flatness. At order Ω^3 , a new z -dependent azimuthal velocity field is generated. This z -dependence is necessary to balance the unequilibrated circumferential shear stress which appears at the free surface when this surface deviates from flatness. The z -dependent azimuthal field appears at fourth order (Ω^4) as a non-conservative force which generates a general circulation as well as a further alteration of the pressure and the shape of the free surface.

In the case of perturbations of a state of rigid rotation with a small differential rotation (Section 13), all of the effects which were just mentioned pile up at first order.

In the case of perturbations from a state of rest the ordering of effects into even and odd powers of Ω is a consequence of symmetry properties of the problem with respect to a change in the sign of Ω . In general the changes in the azimuthal velocity component are associated with the odd powers of Ω and the changes in the azimuthal vorticity field, pressure, and free surface height with even powers of Ω .

The perturbation problems generated at the odd orders in Ω involve inverting ordinary differential equations of Bessel's type and the solutions can be given explicitly as Fourier-Bessel series.

The perturbation problems generated at even orders in Ω involve inverting a fourth order linear operator of the biharmonic type defined in the annulus.

The operators to be inverted at odd and even orders are those which appear first at third and fourth order; the only difference is in the inhomogeneous terms which are formed from the solutions of the problems at lower order. When the solution of the even order problems is known, the inhomogeneous terms for the odd order problems can be computed sequentially. The actual inversion of these odd order problems is trivial. It follows that the inversion of the fourth order problem is a key to the explicit solution of the perturbation problems at even orders and, therefore, at all orders.

It is then of interest that our problem at fourth order is reduced under approximation for small gaps (Section 6) to a biharmonic boundary value problem on a semi-infinite strip. This problem, which is essentially an edge problem in the theory of plane elasticity, is solved by a series of Papkovitch-Fadel functions. We know of no case in elasticity theory where the convergence of these series is proved. Fortunately, in Section 6 we are able to demonstrate convergence of the series for our problem.

In the second chapter of the paper, we turn our attention to simple fluids. It would be helpful if, by observing the way in which a simple fluid climbs in a Couette viscometer, one could obtain information about the viscometric functions. This possibility seems to have been largely discounted in the past; for example, COLEMAN, MARKOVITZ, & NOLL say (p. 48), "We do not expect any general qualitative relation between the viscometric functions and the magnitude of the climbing" and further (p. 67), "... there is no quantitative theory for (climbing), and thus it cannot be used in the evaluation of the viscometric functions."

The perturbation construction which we carry out in Chapter II does give a quantitative theory of climbing when the cylinder speeds are small. In fact, the coefficients of our series, through the fourth order, depend on the constitutive equation of the simple fluid only through constants that are properties of the three viscometric functions. It is not ruled out that this casting out of viscometric coefficients is true at all orders.

Our equation (9.21), which gives the shape of the free surface at second order, depends in a simple way on the second order viscometric coefficients and has a certain potential as a guide for experiments.

The analysis of the simple fluid is carried out in Sections 7-11 through order four; at order four, as in the Newtonian problem treated earlier, secondary motions first appear. The neat ordering of physical effects of slow rotation as well as the *form* of the operators which need to be inverted at each stage of the perturbation are unaltered by the non-Newtonian effects.

The third chapter of the paper is mainly given over to an examination of the effects of surface tension. In Section 12 it is shown how the perturbation analysis of the preceding sections can be extended to problems involving surface tension when a "neutral" wetting angle is prescribed. In Section 13 we consider the effect of perturbing a state of rigid rotation with a small differential shear. Our results in Section 13 are largely qualitative. The zeroth order problem here defines a base state of rigid rotation; with the inclusion of surface tension, this problem calls for solution of a non-linear second order ordinary differential equation for the free

surface profile. This fixes the domain in which all subsequent perturbation problems are to be solved. We derive the relevant first order problem and show that its solution necessarily involves a general circulation. In Section 14 we return to the zeroth order (*i.e.*, state of rigid rotation) and solve the free surface problem for small surface tension. The problem is of a singular perturbation type, and it leads to a boundary layer (corner layer) which scales with the square root of the capillary radius (this is proportional to the square root of the surface tension coefficient). The boundary layer scaling is not altered in the higher order perturbation problems of Section 13, but the boundary layer problems generated in the scaling appear to be very difficult.

We have not yet given the proof of convergence of the perturbation series which are used in the formal analysis in this paper.

2. Statement of the Problem

We shall consider the following problem: An incompressible fluid initially occupies the space \mathcal{V}_0 between two fixed concentric cylinders ($a \leq r \leq b$) and below the free surface $z = h_0(r)$ where it is exposed to pressure p_a of the atmosphere. The inner and outer cylinders are then made to rotate about their common axis with angular velocities Ω and $\lambda\Omega$. The free surface of the rotating fluid cannot retain its static shape and its final steady shape $z = h(r; \Omega)$ is determined by a complex balance of central forces, normal stresses, surface tension, and gravity (see Fig. 1). We seek a mathematical description of the shape of the free surface and of the fluid mechanics which determine this shape.

The following notational conventions will be employed:

$(r, \theta, z), (\mathbf{e}_r, \mathbf{e}_\theta, \mathbf{e}_z)$	Polar cylindrical coordinates, coordinate base vectors.
$T, \rho, \mu, p_a, \mathbf{g} = -\mathbf{e}_z g$	Surface tension, density, viscosity, atmospheric pressure, and gravity.
$p(r, z; \Omega), \bar{\Phi}(r, z; \Omega)$	Pressure, reduced pressure (see below (2.1 a)).
$\mathbf{u}(r, z; \Omega), (u, v, w)$	Velocity, physical components of velocity.
$\mathbf{S}(r, z, \Omega), \mathbf{T} = -p\mathbf{1} + \mathbf{S}$	Extra stress, Cauchy stress tensor.
$h(r; \Omega)$	The equation of the free surface is $z - h(r; \Omega) = 0$.
h', J	dh/dr , mean curvature (see (2.2)).
\mathbf{n}, \mathbf{t}	Outward unit normal to free surface, tangent vector in the intersection of the free surface and the plane $\theta = \text{const.}$ (see Fig. 1.)
\mathcal{V}_Ω	Fluid domain $a \leq r \leq b, z \leq h(r; \Omega)$.
$\mathbf{D} = \frac{1}{2}(\text{grad } \mathbf{u} + (\text{grad } \mathbf{u})^T)$	Stretching tensor.
\mathbf{S}_Γ	Γ^{th} order approximation to the fading memory response functional (2.6).
\mathbf{A}_Γ	Rivlin-Ericksen tensors defined by (2.8).

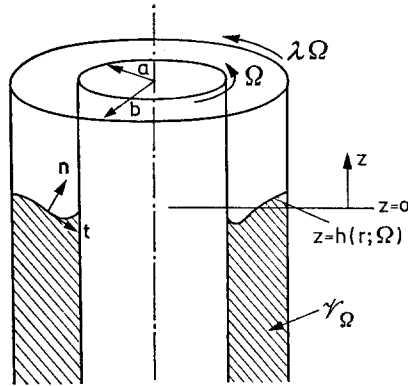

Fig. 1. The free surface between rotating cylinders

It will be assumed throughout that the problem is axisymmetric so that \mathbf{u} and h are independent of θ . A picture of the physical configuration is sketched in Fig. 1.

The problem to be treated in this paper satisfies the following field equations:

$$\rho(\text{grad } \mathbf{u})\mathbf{u} = -\text{grad } \Phi + \text{div } \mathbf{S}, \quad \text{div } \mathbf{u} = 0 \quad \text{in } \mathcal{V}_\Omega, \quad (2.1 a)$$

where

$$(\text{grad } \mathbf{u})\mathbf{u} \equiv (\mathbf{u} \cdot \nabla)\mathbf{u},$$

and for convenience we define

$$\Phi(r, z) \equiv p(r, z) + \rho g z \quad \text{in } \mathcal{V}_\Omega.$$

In addition, the boundary conditions at the cylinder walls are given by

$$\mathbf{u} = \begin{cases} \mathbf{e}_\theta \Omega a & \text{at } r = a, \\ \mathbf{e}_\theta \lambda \Omega b & \text{at } r = b, \end{cases} \quad (2.1 b)$$

and on the free surface of the fluid domain the normal components of the velocity as well as the shear traction vector is to vanish:

$$\mathbf{u} \cdot \mathbf{n} = S_{n\theta} = S_{nt} = 0 \quad \text{at } z = h(r; \Omega). \quad (2.1 c)$$

Moreover, far from the free surface we specify that the axial velocity field and the shear traction field on right cross-sectional planes vanish:

$$\mathbf{u} \cdot \mathbf{e}_z, S_{z\theta}, S_{zr} \rightarrow 0 \quad \text{as } z \rightarrow -\infty. \quad (2.1 d)$$

The problem so far given could be considered fully stated if the constitutive relations of the fluid were given and if the free surface profile $z = h(r; \Omega)$ were known in advance. Actually the particular surface profile which develops is the one which allows a balance between the normal component of the jump in stress

across the free surface and the surface tension. Thus, at $z=h(r; \Omega)$,

$$\mathbf{n} \cdot [-p\mathbf{I} + \mathbf{S}] \cdot \mathbf{n} = TJ = \frac{T}{r} (rh' / \sqrt{1+h'^2})' \tag{2.2a}$$

where J is the mean curvature written for surfaces of axial symmetry, and the square bracket gives the jump in stress across the free surface:

$$\begin{aligned} \mathbf{n} \cdot [-p\mathbf{I} + \mathbf{S}] \cdot \mathbf{n} &= [-p + S_{nn}] = (-p + S_{nn}) - (-p_a) \\ &= -\Phi + p_a + S_{nn} + \rho gh(r; \Omega) \quad \text{at } z=h(r; \Omega). \end{aligned} \tag{2.2b}$$

The normal traction acting on the free surface from above has been taken as atmospheric pressure. Equation (2.2a) is a second order inhomogeneous ordinary non-linear differential equation; it is to be solved subject to prescribed conditions for the slopes $h'(a; \Omega)$ and $h'(b; \Omega)$ (*i.e.*, the wetting angles are given). We observe that the scalar quantity Φ is included in (2.2a), but from (2.1) it is determined only up to an arbitrary additive constant. This constant, and the plane on which $z=0$, is fixed by the condition that the total volume below the free surface is conserved:

$$\int_a^b rh(r; \Omega) dr = 0. \tag{2.1e}$$

It will be convenient in the following to have expressions for the free surface conditions in terms of components appropriate to cylindrical coordinates. To this end, let α denote the angle between \mathbf{e}_z and \mathbf{n} ($-\frac{\pi}{2} \leq \alpha \leq \frac{\pi}{2}$) so that $\sin \alpha = h' / \sqrt{1+h'^2}$. Then

$$\mathbf{u} \cdot \mathbf{n} = (\cos \alpha) w - (\sin \alpha) u,$$

$$S_{n\theta} = (\cos \alpha) S_{z\theta} - (\sin \alpha) S_{r\theta},$$

$$S_{nr} = \sin \alpha \cos \alpha (S_{zz} - S_{rr}) + (\cos^2 \alpha - \sin^2 \alpha) S_{rz},$$

and

$$S_{nn} = S_{zz} \cos^2 \alpha + S_{rr} \sin^2 \alpha - 2 \sin \alpha \cos \alpha S_{zr}.$$

Noting that $S_{nr} = 0$ on $z=h(r; \Omega)$, we may eliminate S_{rz} between the last two equations to find that

$$S_{nn} = S_{zz} - S_{zr} \tan \alpha. \tag{2.3}$$

In summary, the most general mathematical problem to be considered is as follows:

$$\rho(\text{grad } \mathbf{u}) \mathbf{u} = -\text{grad } \Phi + \text{div } \mathbf{S}, \quad \text{div } \mathbf{u} = 0 \quad \text{in } \mathcal{V}_\Omega, \tag{2.4a, b}$$

$$\mathbf{u} = \begin{cases} \mathbf{e}_\theta \Omega a & \text{at } r=a, \\ \mathbf{e}_\theta \lambda \Omega b & \text{at } r=b, \end{cases} \tag{2.4c}$$

$$w - h'u = S_{z\theta} - h'S_{r\theta} = h'(S_{zz} - S_{rr}) + (1 - h'^2) S_{rz} = 0 \quad \text{at } z=h(r; \Omega), \tag{2.4d, e, f}$$

$$w = S_{z\theta} = S_{zr} = 0 \quad \text{at } z = -\infty, \tag{2.4g}$$

and

$$p_a - \Phi + S_{zz} - h'S_{rz} + \rho gh = \frac{T}{r} (rh' / \sqrt{1+h'^2})' \quad \text{at } z=h(r; \Omega), \tag{2.4h}$$

where $h'(a; \Omega)$ and $h'(b; \Omega)$ are given, and Φ is made definite by requiring the condition of constant volume (2.1 e). We are going to treat this problem both for Newtonian liquids and for simple fluids with fading memory.

For an incompressible Newtonian fluid, the constitutive relation has the form

$$S = 2\mu D, \quad (2.5)$$

where μ is the viscosity and D is the stretching tensor. A generalization which includes (2.5) is the concept of an incompressible simple fluid. TRUESDELL & NOLL [17] define this material through the constitutive assumption

$$S = \mathcal{J}_{s=0}^{\infty} [G(s)], \quad G(s) \equiv C_t(t-s) - \mathbf{1}, \quad (2.6a)$$

where the response functional \mathcal{J} satisfies the principle of frame indifference;

$$Q \mathcal{J}_{s=0}^{\infty} [G(s)] Q^T = \mathcal{J}_{s=0}^{\infty} [Q G(s) Q^T] \quad (2.6b)$$

for all fixed orthogonal tensors Q . Here, the symmetric tensor C_t is the relative right Cauchy-Green strain tensor. It is calculated from the relative deformation gradient tensor F_t through $C_t = F_t^T F_t$, where $F_t = \text{grad } \chi_t$ and $\xi \equiv \chi_t(\chi, \tau)$ denotes the point occupied at time $\tau \leq t$ by the particle which at time t is at the point x . Since the motion of an incompressible fluid is isochoric, the determinant of F_t (and, hence, of C_t) is constant and equal to one—its value at $\tau = t$. Further, since incompressibility requires the introduction of the scalar function p into the Cauchy stress tensor, \mathcal{J} cannot be uniquely defined for each incompressible fluid unless uniqueness is forced by convention. The usual convention adopted here is that p is the mean normal stress and, therefore, in addition to (2.6a) and (2.6b), we require

$$\text{tr } \mathcal{J}_{s=0}^{\infty} [G(s)] = 0. \quad (2.6c)$$

The problem (2.4), even for a Newtonian fluid (2.5), is too difficult to treat generally. However, it is possible to construct perturbation series solutions pivoted about the rest state ($\Omega = 0$) or the state of rigid rotation ($\lambda = 1$). Both of these states are, in fact, solutions of (2.4) for any given simple fluid. For either state, the relative strain history $C_t(\tau) \tau \leq t$ is always equal to its present value of $\mathbf{1}$ in all past configurations. Thus from (2.6) it follows that the extra stress S vanishes (see [1], p. 20). In addition, since rigid body steady rotation possesses an acceleration potential, in both cases Φ is determinate, and it remains only to integrate the reduced form of the surface tension equation (2.4 h).

In our analysis of simple fluids, we shall assume that the response functional \mathcal{J} is of the fading memory type. We note that since $\Omega = 0$ is a rest state, the steady velocity $u(x; \Omega)$ and the relative history

$$G(s; \Omega) = C_t(t-s; \Omega) - \mathbf{1} \quad (2.6d)$$

both vanish when $\Omega = 0$. Then assuming that

$$u(x; \Omega) = \Omega \tilde{u}(x; \Omega)$$

where $\tilde{u}(x, 0)$ is a bounded field (as is true when u is analytic), we note further that the relative motion $\xi = \chi_t(x, t-s)$ satisfies an autonomous differential system

$$\frac{d\xi(t-s)}{ds} = -\Omega \tilde{u}[\xi(t-s); \Omega], \quad \xi(t-s)|_{s=0} = x.$$

The solution of this problem is in the form

$$\xi(t-s) = \Psi[x, t-\Omega s; \Omega],$$

where

$$\Psi'[x, t-\Omega s; \Omega] = \tilde{u}[\xi(t-s); \Omega]$$

with the prime denoting differentiation with respect to the second place in Ψ and

$$\Psi(x, t; \Omega) = x.$$

Hence

$$x_t(x, t-s; \Omega) = \Psi(x, t-\Omega s; \Omega),$$

and G has the structure

$$G(s; \Omega) = H(\Omega s; \Omega) \equiv H_\Omega,$$

where H_Ω is the retardation (in the sense of COLEMAN & NOLL [2]) of $H(s; \Omega)$; $H(s; \Omega)$ is defined through (2.6d), (2.6a) and the definition of C_t (following (2.6b)).

Under certain technical conditions [2], which may be assumed here, a complete n^{th} order approximation to the response functional of a general simple fluid with fading memory is provided by the response function of a fluid of the differential type of grade n . We shall need the approximations up to grade 4, which are listed below:

$$S = S_1 + S_2 + S_3 + S_4,$$

where

$$S_1 = \mu A_1,$$

$$S_2 = \alpha_1 A_2 + \alpha_2 A_1^2,$$

$$S_3 = \beta_1 A_3 + \beta_2 (A_2 A_1 + A_1 A_2) + \beta_3 (\text{tr } A_2) A_1, \tag{2.7}$$

$$S_4 = \gamma_1 A_4 + \gamma_2 (A_3 A_1 + A_1 A_3) + \gamma_3 A_2^2 + \gamma_4 (A_2 A_1^2 + A_1^2 A_2) \\ + \gamma_5 (\text{tr } A_2) A_2 + \gamma_6 (\text{tr } A_2) A_1^2 + \gamma_7 (\text{tr } A_3) A_1 + \gamma_8 (\text{tr } A_2 A_1) A_1.$$

Here, $\mu, \alpha_1, \alpha_2, \beta_1, \beta_2, \beta_3, \gamma_1, \dots, \gamma_8$ are material constants; and A_Γ ($\Gamma = 1, \dots, 4$) represent the first four Rivlin-Ericksen tensors, which are defined in terms of the relative strain C_t by

$$A_\Gamma \equiv (-1)^\Gamma \frac{d^\Gamma}{ds^\Gamma} C_t(t-s)|_{s=0}. \tag{2.8}$$

We remark, in particular, that $A_1 = 2D$, as was recorded earlier. In general, it is necessary to include a multiple of $\mathbf{1}$ added on the right of the first of equations

(2.7) in order to satisfy (2.6c). However, this multiple may be absorbed into the constitutively indeterminate pressure p of T .

Not all of the material constants appearing in (2.7) are properties of the three viscometric functions which appear in studies on steady viscometric flows. Since we shall find in Chapter II that the series solution up to the highest order constructed (*i.e.*, Ω^4) depends on the material only through those constants in (2.7) which are characteristic of the viscometric functions, we feel a particular need to draw attention to the viscometric constants here.

In [17] it is shown that a complete kinematic characterization of the class of viscometric flows with shear rate κ is that the only non-zero Rivlin-Ericksen tensors are A_1 and A_2 ; moreover, these are given by

$$A_1 = \kappa(N + N^T), \quad A_2 = 2\kappa^2 N^T N. \quad (2.9)$$

$N = \mathbf{b}_1 \otimes \mathbf{b}_2$ is defined relative to an orthonormal basis $(\mathbf{b}_1, \mathbf{b}_2, \mathbf{b}_3)$ where \mathbf{b}_1 denotes the local direction of shear and \mathbf{b}_2 denotes a unit normal to the local shearing surface. In such flows the extra-stress for an incompressible simple fluid reduces to the form

$$S = \tau(\kappa)(N + N^T) + \sigma_1(\kappa)N^T N + \sigma_2(\kappa)NN^T, \quad (2.10)$$

where τ , σ_1 and σ_2 denote the shear and two normal stress viscometric functions, respectively. Thus, by substituting (2.9) into (2.7) and comparing with (2.10) it follows that (see page 495 of [17])

$$\begin{aligned} \tau(\kappa) &= \mu\kappa + 2(\beta_2 + \beta_3)\kappa^3 + o(\kappa^3), \\ \sigma_1(\kappa) &= (2\alpha_1 + \alpha_2)\kappa^2 + 4(\gamma_3 + \gamma_4 + \gamma_5 + \frac{1}{2}\gamma_6)\kappa^4 + o(\kappa^4), \\ \sigma_2(\kappa) &= \alpha_2\kappa^2 + 2\gamma_6\kappa^4 + o(\kappa^4). \end{aligned} \quad (2.11)$$

With these preliminaries aside, we are ready to consider the domain perturbation theory. Though our main concern is with free surface problems in which the fluid domain is sought as an unknown, it is instructive to give brief consideration to problems in which the deformation of the domain is prescribed. These prescribed domain deformation problems are considered next.

Chapter I. A Domain Perturbation Theory

3. Prescribed Domain Deformation; Generalization of Hadamard's Formula

The following elementary eigenvalue problem arises in the theory of hydrodynamic stability [14] and in the theory of small vibrations of incompressible elastic plates [11]:

$$\begin{aligned} \Delta \mathbf{u} + \lambda \mathbf{u} + \text{grad } p &= 0, \quad \text{div } \mathbf{u} = 0 \quad \text{in } \mathcal{V}, \\ \mathbf{u} &= 0 \quad \text{on } \partial \mathcal{V}. \end{aligned} \quad (3.1 \text{ a, b, c})$$

Here, \mathcal{V} denotes the bounded open three-dimensional configuration of the body and $\partial\mathcal{V}$ its boundary. One problem of interest to study in these theories is the dependence of the eigenvalues and eigenfunctions on the domain. In the present section, we shall briefly describe how this can be accomplished using a domain perturbation method.

Suppose that the problem (3.1) is difficult to solve for in the domain \mathcal{V} but that the eigenvalues and eigenfunctions can be found in another domain \mathcal{V}_0 of simple shape. To study (3.1) in \mathcal{V} , we imbed \mathcal{V} in a one (τ) parameter family of domains \mathcal{V}_τ . The problem (3.1) in \mathcal{V}_τ is then mapped onto \mathcal{V}_0 where it may be studied using all the simplifying features which apply in \mathcal{V}_0 . These simplifying features are particularly nice when the problem is studied by perturbation theory. Then it is possible to construct eigenvalues and eigenfunctions by developing the mapped problem in \mathcal{V}_0 into a Taylor series in τ . The advantage is that the coefficients for the Taylor series are determined as solutions of linear boundary value problems obtained by successively differentiating the mapped problem with respect to τ and evaluating the resulting equations at $\tau=0$, that is, in \mathcal{V}_0 .

We want next to exhibit the formal procedure by which we simplify the calculation of derivatives of eigenvalues and eigenfunctions with respect to τ . Our purpose in treating a *prescribed* domain deformation problem at this early stage is to exhibit the basic ideas unencumbered by largely extraneous free surface complications. It is perhaps appropriate to remark that prescribed domain deformation problems are generic in mathematical science and of considerable independent interest. The basic ideas which we need are found already in the procedure which was first developed in [9] and which is used below to calculate $d\Lambda/d\tau$.

We first select an arbitrary admissible mapping of $\mathcal{V}_0 + \partial\mathcal{V}_0 \rightarrow \mathcal{V}_\tau + \partial\mathcal{V}_\tau$: $\mathbf{x} = \mathbf{x}(x_0, \tau)$ where $x_0 \in \mathcal{V}_0 + \partial\mathcal{V}_0$ and $\mathbf{x} \in \mathcal{V}_\tau + \partial\mathcal{V}_\tau$, and introduce the associated substantial derivative

$$\frac{d(\cdot)}{d\tau} \equiv \frac{\partial(\cdot)}{\partial\tau} + [\text{grad}(\cdot)]V_\tau, \quad (3.2)$$

where $V_\tau \equiv \frac{d\mathbf{x}}{d\tau}$ is the deformation rate of the mapping. The motivation for this initial step lies in the observation that $\frac{d^n}{d\tau^n}\{(3.1)\} = 0$, since (3.1) is an identity in τ . Since the field equations of (3.1) are also identities in $\mathbf{x} \in \mathcal{V}_\tau$, it follows that $\frac{\partial^n}{\partial\tau^n}\{(3.1 \text{ a, b})\} = 0$ in \mathcal{V}_τ .

Thus, for $n=1$, we have

$$\Delta \mathbf{u}_\tau + \Lambda \mathbf{u}_\tau + \dot{\Lambda} \mathbf{u} + \text{grad } p_\tau = 0, \quad \text{div } \mathbf{u}_\tau = 0 \quad \text{in } \mathcal{V}_\tau, \quad (3.3 \text{ a, b})$$

where we have used the notation $\mathbf{u}_\tau \equiv \frac{\partial \mathbf{u}}{\partial \tau}$ and $\dot{\Lambda} \equiv \frac{d\Lambda}{d\tau}$. Since the full substantial derivative must be used on the boundary, (3.1 c) becomes

$$\frac{d\mathbf{u}}{d\tau} = \mathbf{u}_\tau + (\text{grad } \mathbf{u})V_\tau = 0 \quad \text{on } \partial\mathcal{V}_\tau. \quad (3.3 \text{ c})$$

We shall now show that for any τ ,

$$\dot{\Lambda}(\tau) = - \frac{\int_{\partial \mathcal{V}_\tau} \left| \frac{\partial \mathbf{u}}{\partial n} \right|^2 \mathbf{V}_\tau \cdot \mathbf{n} da}{\int_{\mathcal{V}_\tau} |\mathbf{u}|^2 dv}, \tag{3.4}$$

where $\mathbf{V}_\tau \cdot \mathbf{n}$ denotes the domain deformation rate in the outer normal direction to the boundary $\partial \mathcal{V}_\tau$. Before obtaining this result, however, it is convenient to observe that (3.4) represents a generalization of the well known Hadamard (1908) formula for elastic membranes. Our result implies that $\Lambda(\tau)$ decreases as the domain \mathcal{V}_τ is enlarged (i.e., $V_n > 0$). In fact, globally it shows that $\Lambda(\tau_2) < \Lambda(\tau_1)$ whenever \mathcal{V}_{τ_1} is entirely contained in \mathcal{V}_{τ_2} . The monotonicity of Λ with \mathcal{V} could be obtained directly from the variational characterization of eigenvalues Λ as minimum problems, but, of course, (3.4) goes much further.

We now turn to the derivation of (3.4). It readily follows from (3.3a, b), (3.1), and application of the divergence theorem that

$$\begin{aligned} 0 &= \int_{\mathcal{V}_\tau} (\Delta \mathbf{u}_\tau + \Lambda \mathbf{u}_\tau + \dot{\Lambda} \mathbf{u} + \text{grad } p_\tau) \cdot \mathbf{u} dv \\ &= \dot{\Lambda} \int_{\mathcal{V}_\tau} |\mathbf{u}|^2 dv - \int_{\mathcal{V}_\tau} \mathbf{u}_\tau \cdot \text{grad } p dv - \int_{\partial \mathcal{V}_\tau} (\text{grad } \mathbf{u}) \mathbf{n} \cdot \mathbf{u}_\tau da. \end{aligned} \tag{3.5}$$

Substituting the boundary information (3.3c) into the last integral in (3.5), we see that the integrand is equivalently $-(\text{grad } \mathbf{u}) \mathbf{n} \cdot (\text{grad } \mathbf{u}) \mathbf{V}_\tau$. But on the boundary (3.1c) shows that $\text{grad } \mathbf{u} = \frac{\partial \mathbf{u}}{\partial n} \mathbf{n}$, so that the integrand becomes $-\left| \frac{\partial \mathbf{u}}{\partial n} \right|^2 \mathbf{V}_\tau \cdot \mathbf{n}$.

Thus, to complete the proof of (3.4), we must show that in (3.5)

$$\int_{\mathcal{V}_\tau} \mathbf{u}_\tau \cdot \text{grad } p dv = 0.$$

To see this we start with the observation from (3.1 b, c) and the divergence theorem that

$$\int_{\mathcal{V}_\tau} \mathbf{u} \cdot \text{grad } p dv = 0$$

is an identity in τ . Thus, by use of the properties of substantial differentiation,

$$0 = \frac{d}{d\tau} \int_{\mathcal{V}_\tau} \mathbf{u} \cdot \text{grad } p dv = \int_{\mathcal{V}_\tau} \frac{\partial}{\partial \tau} (\mathbf{u} \cdot \text{grad } p) dv + \int_{\partial \mathcal{V}_\tau} (\mathbf{u} \cdot \text{grad } p) \mathbf{V}_\tau \cdot \mathbf{n} da.$$

Since the latter integral is zero due to (3.1c), we reach

$$\int_{\mathcal{V}_\tau} (\mathbf{u}_\tau \cdot \text{grad } p dv = - \int_{\mathcal{V}_\tau} \mathbf{u} \cdot \text{grad } p_\tau dv.$$

Clearly the right-hand side above vanishes by application of the divergence theorem and (3.1 b, c). With this established, the result (3.4) follows.

We emphasize that the result (3.4) allows only the normal shift of a boundary to affect an associated change in the eigenvalue. In attaining this result, our argument justifies and simplifies that used by HADAMARD for his simpler problem.

We expect that HADAMARD's argument would also lead to (3.4), but it requires a somewhat less direct and partly intuitive approach.* The major advantage of the present method of derivation over that which could be constructed from the ideas of [8] is that here we avoid having to extend the domain mapping of the boundary specifically into the interior of \mathcal{V}_τ ; independence of the result on the interior mapping function is unquestionably clear.

In order actually to calculate $\dot{A}(\tau)$ using (3.4), we need the eigenvalue and associated eigenfunctions of (3.1) in \mathcal{V}_τ . Since these are more easily established in \mathcal{V}_0 , we are naturally motivated to construct the series

$$A(\tau) = A(0) + \tau \dot{A}(0) + \frac{\tau^2}{2} \ddot{A}(0) + \dots, \tag{3.6}$$

where now $A(0)$ is computable.

Calculation of $d^2A(\tau)/d\tau^2$ is more complicated; in particular, this calculation will require prior computation of the field \mathbf{u}_τ which solves (3.3). When A is simple, the unique solvability of (3.3) subject to an appropriate normalizing condition, say

$$\int_{\mathcal{V}_\tau} |\mathbf{u}|^2 dv = 1,$$

is guaranteed by (3.4) which is a form of the Fredholm alternative. Of course, if we cannot solve (3.1) in \mathcal{V}_τ , we could not hope to solve (3.3) there. In the domain \mathcal{V}_0 of simple shape, it may be easier; this observation suggests that we construct the series

$$\mathbf{u} = \mathbf{u}|_{\tau=0} + \tau \left. \frac{d\mathbf{u}}{d\tau} \right|_{\tau=0} + \dots \tag{3.7}$$

Of course, since the Taylor coefficients $\mathbf{u}|_{\tau=0}$ and $\left. \frac{d\mathbf{u}}{d\tau} \right|_{\tau=0}$ are determined in \mathcal{V}_0 , they are naturally functions of \mathbf{x}_0 . To obtain the solution in \mathcal{V}_τ , we need first to substitute the inverse functions $\mathbf{x}_0 = \mathbf{x}_0(\mathbf{x}, \tau)$ in the functions on the right-hand side of (3.7).

It serves no further purpose to continue the construction to higher orders in τ . The type of problem which is encountered at these higher orders is similar to that already mentioned above.

We have intentionally deferred any specific discussion of the domain mapping function to the following section where we develop the analogous domain perturbation method for the free surface problem, which is the subject of this paper.

4. Free Surface Domain Deformations. The Shape of the Free Surface on a Newtonian Liquid at Lowest Order

The free surface problem for a Newtonian liquid is given by (2.4) and (2.5). For the present we take $T=0$, fix λ and consider small values of Ω . Associated with the value $\Omega=0$ is the reference fluid domain \mathcal{V}_0 defined by the coordinates (r_0, θ_0, z_0) with $a \leq r_0 \leq b$, $0 \leq \theta_0 < 2\pi$, and $-\infty < z_0 \leq h^{[0]}(r_0)$. We shall see that

* GARABEDIAN [4] is a convenient reference.

when $T = \Omega = 0$ then $h^{[0]}(r_0) \equiv 0$. Associated with the value Ω is the domain \mathcal{V}_Ω with coordinates (r, θ, z) . As in the prescribed domain deformation problem considered in Section 3, we define a mapping

$$r = r_0, \quad \theta = \theta_0, \quad z = \phi(r_0, z_0; \Omega) \quad (4.1)$$

carrying \mathcal{V}_0 into \mathcal{V}_Ω .^{*} We assume that ϕ is invertible, even in Ω^{**} , and such that

$$\phi(r_0, z_0; 0) = z_0$$

and

$$\phi(r_0, 0; \Omega) = h(r; \Omega), \quad (4.2)$$

where $-\infty < \phi(r_0, z_0; \Omega) \leq h(r; \Omega)$. Here, $h(r; \Omega)$ denotes the height of the free surface of \mathcal{V}_Ω .

There is a formal similarity between (4.1) and (4.2) and material particle mappings. This similarity is further accentuated by the definition of a domain deformation rate field,

$$V_\Omega = V_\Omega e_z \equiv \frac{d\phi}{d\Omega} e_z, \quad (4.3)$$

and a related substantial derivative

$$\frac{d(\cdot)}{d\Omega} \equiv \frac{\partial(\cdot)}{\partial\Omega} + [\text{grad}(\cdot)] V_\Omega = \frac{\partial(\cdot)}{\partial\Omega} + V_\Omega \frac{\partial(\cdot)}{\partial z}. \quad (4.4)$$

The reader is enjoined not to confuse the mappings (4.1) and (4.2) and the associated formulas (4.3) and (4.4) with the analogous relations which hold relative to material particle mappings associated with Eulerian and Lagrangian coordinates. The deformation (4.1) is chosen *ab initio*, and any mapping satisfying the conditions (4.2) will suffice. For example, we could take $z = \phi(r_0, z_0; \Omega) \equiv z_0 + h(r; \Omega)$. The deformation (4.1) is independent of the interior motion of material particles and the velocity field \mathbf{u} which is associated with the material mapping.

The substantial derivative (4.4) is a key operator in the algorithm for constructing the perturbation series to follow; indeed,

$$\begin{Bmatrix} \mathbf{u} \\ \Phi \\ h \end{Bmatrix} = \sum_0^\infty \frac{1}{n!} \begin{Bmatrix} \mathbf{u}^{[n]} \\ \Phi^{[n]} \\ h^{[n]} \end{Bmatrix} \Omega^n, \quad (4.5)$$

where, for example,

$$\mathbf{u}^{[n]}(r_0, z_0) \equiv \left. \frac{d^n \mathbf{u}}{d\Omega^n} \right|_{\Omega=0}. \quad (4.6)$$

Of course, we seek the solution in \mathcal{V}_Ω rather than in \mathcal{V}_0 , and in order to achieve this goal, the independent variables (r_0, z_0) must be replaced by (r, z) via the inverse of the particular domain mapping $\mathcal{V}_0 \rightarrow \mathcal{V}_\Omega$ introduced in (4.1), (4.2). This suggests that the domain mapping function ϕ may enter the solution in \mathcal{V}_Ω .

^{*} Since the problems considered in the paper are axisymmetric, we shall drop all further explicit mention of the azimuthal coordinate θ .

^{**} Here it is natural to consider a domain mapping function that is an even function of Ω since the fluid domain is independent of the direction of rotation.

However, this entry can only be superficial since we know that the solution in \mathcal{V}_Ω is certainly independent of the domain mapping because there is no reference to any such thing in the statement of the problem. The concept of domain mapping is introduced only for convenience, and, therefore, it must follow that while the particular mapping function no doubt enters at various orders in the infinite perturbation series (4.5) when evaluated in \mathcal{V}_Ω , it does so only to be nullified in the full summation when its complete dependence through all orders is taken into account.

The following observation is central to our procedure for forming the perturbation series (4.5) for the solution. Since each of the equations (2.4) and (2.5) is an identity in Ω , (2.4) and (2.5) may each be substantially differentiated any number of times with respect to Ω . For example, we may write

$$\frac{d^n}{d\Omega^n}(\text{div } \mathbf{u}) = 0 \quad \text{in } \mathcal{V}_\Omega$$

and

$$\frac{d^n}{d\Omega^n}(S_{z\theta} - h' S_{r\theta}) = 0 \quad \text{at } z = h(r; \Omega). \tag{4.7}$$

A major simplification is possible because equations (2.4a, b, c) are also identities in z . From this fact it follows that

$$(2.4a, b, c)^{(n)} \equiv \frac{\partial}{\partial \Omega^n} (2.4a, b, c) = 0. \tag{4.8}$$

To prove this, consider for example (2.4b) and suppose that

$$\frac{\partial^{n-1}}{\partial \Omega^{n-1}} \text{div } \mathbf{u} = \text{div } \frac{\partial^{n-1} \mathbf{u}}{\partial \Omega^{n-1}} = \text{div } \mathbf{u}^{(n-1)} = 0 \quad \text{in } \mathcal{V}_\Omega. \tag{4.9}$$

Then, with the aid of (4.4),

$$\begin{aligned} \frac{d}{d\Omega} \text{div } \mathbf{u}^{(n-1)} &= \text{div } \mathbf{u}^{(n)} + V_\Omega \frac{\partial}{\partial z} \text{div } \mathbf{u}^{(n-1)} \\ &= \text{div } \mathbf{u}^{(n)} = 0 \quad \text{in } \mathcal{V}_\Omega. \end{aligned} \tag{4.10}$$

Thus, since (4.9) is true with $n=1$, we have by induction one of the results (4.8); and the others follow similarly. It is perhaps useful to note that since equations (2.4d, e, f, g) are evaluated on the free surface $z=h(r; \Omega)$, they are not identities in z and, therefore, do not share the property (4.8); substantial derivatives are required at the free boundary.

It will be convenient in the remainder of this paper to utilize the superscript notation of (4.8) with the additional requirement that after differentiation the result is evaluated at $\Omega=0$. Thus, analogous to the notation established in (4.6), we define

$$(\cdot)^{(n)} \equiv \left. \frac{\partial^n (\cdot)}{\partial \Omega^n} \right|_{\Omega=0}. \tag{4.11}$$

Also, instead of (r_0, z_0) , it will be convenient to write (r, z) when it is clear from the context that we mean points of \mathcal{V}_0 .

At zeroth order₁ ($\Omega=0$), the fluid body is in its basic state of rest. Thus, in the absence of surface tension it follows from (2.4), (2.5), and in the notation established above, that

$$\mathbf{u}^{[0]} = h^{[0]} = S^{[0]} = 0, \quad \Phi^{[0]} = p_a. \tag{4.12}$$

This gives the leading term in the power series solution (4.5), and we now want to establish the first order solution and show in particular that

$$h^{[1]} = 0. \tag{4.13}$$

At first order the following problem, which is obtained by differentiating (2.4) with respect to Ω , must be solved:

$$\rho [(\text{grad } \mathbf{u}) \mathbf{u}]^{(1)} = -\text{grad } \Phi^{(1)} + \mu \Delta \mathbf{u}^{(1)} = 0, \tag{4.14a}$$

$$\text{div } \mathbf{u}^{(1)} = 0 \quad \text{in } \mathcal{V}_0, \tag{4.14b}$$

where

$$\mathbf{u}^{(1)} = \begin{cases} \mathbf{e}_\theta a & \text{at } r = a, \\ \mathbf{e}_\theta \lambda b & \text{at } r = b \end{cases} \tag{4.14c, d}$$

and

$$w^{(1)} = S_{z\theta}^{(1)} = S_{rz}^{(1)} = 0 \quad \text{at } z = 0, -\infty \tag{4.14e, f, g}$$

This problem is a Stokes flow problem, and up to an indeterminate constant in $\Phi^{(1)}$ it has a unique single-valued solution in \mathcal{V}_0 given by

$$\mathbf{u}^{(1)} = \left(Ar + \frac{B}{r} \right) \mathbf{e}_\theta, \quad \Phi^{(1)} = \text{constant}, \tag{4.15}$$

where

$$A = \frac{b^2 \lambda - a^2}{b^2 - a^2}, \quad B = \frac{a^2 b^2 (1 - \lambda)}{b^2 - a^2}.$$

It follows from (4.4) and (4.12) that

$$\mathbf{u}^{[1]} = \mathbf{u}^{(1)} \quad \text{and} \quad \Phi^{[1]} = \Phi^{(1)}.$$

The value of $h^{[1]}$ and the constant in $\Phi^{(1)}$ can now be determined from the restriction that develops by taking the first Ω derivative of the condition of constant volume (2.1e) and the equation

$$-\Phi^{(1)} + S_{zz}^{[1]} - (h' S_{rz})^{[1]} + \rho g h^{[1]} = -\Phi^{(1)} + S_{zz}^{(1)} + \rho g h^{[1]} = 0,$$

which arises as the first Ω derivative of (2.4h) when $T=0$. Since (4.15) implies that $S_{zz}^{(1)}=0$, we must have $h^{[1]}=0$, and the constant in $\Phi^{(1)}$ is zero.

Since $h^{[1]}=0$, we have, using (4.2), (4.3), (4.4), and the notation of (4.5) and (4.11), that

$$\begin{aligned} (\cdot)^{[1]} &= \frac{d(\cdot)}{d\Omega} \Big|_{\Omega=0} = \frac{\partial(\cdot)}{\partial\Omega} \Big|_{\Omega=0} + h^{[1]} \frac{\partial(\cdot)}{\partial z} \Big|_{\Omega=0} \\ &= \frac{\partial(\cdot)}{\partial\Omega} \Big|_{\Omega=0} = (\cdot)^{(1)} \end{aligned} \tag{4.16}$$

on the free surface where the substantial derivative is essential. This result yields in the notation of (4.5) and (4.11) the following useful differentiation formulae which are valid at the free surface:*

$$\begin{aligned}
 (\cdot)^{[2]} &= (\cdot)^{(2)} + h^{[2]} \left\{ \frac{\partial(\cdot)}{\partial z} \right\}^{(0)}, \\
 (\cdot)^{[3]} &= (\cdot)^{(3)} + h^{[3]} \left\{ \frac{\partial(\cdot)}{\partial z} \right\}^{(0)} + 3h^{[2]} \left\{ \frac{\partial(\cdot)}{\partial z} \right\}^{(1)}, \\
 (\cdot)^{[4]} &= (\cdot)^{(4)} + h^{[4]} \left\{ \frac{\partial(\cdot)}{\partial z} \right\}^{(0)} + 4h^{[3]} \left\{ \frac{\partial(\cdot)}{\partial z} \right\}^{(1)} \\
 &\quad + 6h^{[2]} \left\{ \frac{\partial(\cdot)}{\partial z} \right\}^{(2)} + 3(h^{[2]})^2 \left\{ \frac{\partial^2(\cdot)}{\partial z^2} \right\}^{(0)}.
 \end{aligned}
 \tag{4.17}$$

We now consider the boundary value problems that arise at higher orders, the solutions of which determine the Taylor coefficients in the series representation (4.5). At order n , the appropriate problem which is obtained by differentiating (2.4) n times with respect to Ω is summarized below:

$$\rho[(\text{grad } \mathbf{u})]^{(n)} = -\text{grad } \Phi^{(n)} + \mu \Delta \mathbf{u}^{(n)} \quad \text{in } \mathcal{V}_0, \tag{4.18a}$$

$$\text{div } \mathbf{u}^{(n)} = 0 \quad \text{in } \mathcal{V}_0, \quad \mathbf{u}^{(n)} = 0 \Big|_{r=a, r=b} \tag{4.18b, c, d}$$

and at $z=0$,

$$\begin{aligned}
 (w - u h')^{[n]} &= (S_{z\theta} - h' S_{r\theta})^{[n]} \\
 &= (h' [S_{rr} - S_{zz}] - [1 - (h')^2] S_{rz})^{[n]} = 0.
 \end{aligned}
 \tag{4.18e}$$

In addition, from (2.4g) we shall also require that $w^{(n)}$, $S_{z\theta}^{(n)}$, and $S_{zr}^{(n)}$ vanish as $z \rightarrow -\infty$.

An important consequence of the fact that $\mathbf{u}^{(0)}$ and $h^{[1]}$ both vanish is that problem (4.18) is an inhomogeneous Stokes flow problem at any order n . The inhomogeneous terms are dependent only on the solutions at lower order than n . Thus, if the solutions at all orders less than n are known, then any single valued solution at order n is unique up to an additive constant in $\Phi^{(n)}$. In order to determine this additive constant, it is necessary to apply the free surface condition (2.4h) and the constant volume condition (2.1e), which at order n are, respectively,

$$(-\Phi + S_{zz} - h' S_{rz} + \rho g h)^{[n]} = 0 \quad \text{at } z=0 \tag{4.18f}$$

and

$$\int_a^b r h^{[n]} dr = 0. \tag{4.18g}$$

Thus, not only is the additive constant in $\Phi^{(n)}$ determined, but also the free surface correction coefficient $h^{[n]}$ at the n^{th} order is obtained.

Finally, in order to obtain the n^{th} order contribution to the series solution (4.5) in \mathcal{V}_Ω of any interior field quantity, we have still to calculate the substantial deriva-

* These formulae also apply to the interior of \mathcal{V}_0 if, for example, the domain mapping $z = \phi(r_0, z_0, \Omega) = z_0 + h(r_0; \Omega)$ is adopted.

tives of the various fields at order n using (4.4), and then to transform the final results from \mathcal{V}_0 to \mathcal{V}_Ω via the domain mapping (4.1).*

At second order ($n=2$), we find that

$$\begin{aligned} \rho [(\text{grad } \mathbf{u}) \mathbf{u}]^{(2)} &= -2\rho (v^{(1)})^2 e_r/r = -\text{grad } \Phi^{(2)} + \mu \Delta \mathbf{u}^{(2)}, \\ \text{div } \mathbf{u}^{(2)} &= 0 \quad \text{in } \mathcal{V}_0, \\ \mathbf{u}^{(2)} &= 0 \quad \text{at } r=a \quad \text{and } r=b. \end{aligned} \tag{4.19a}$$

The free surface conditions (4.18e, f) at order 2 can be written with the aid of the results of the zeroth and first order solutions as

$$w^{[2]} = S_{z\theta}^{[2]} = S_{rz}^{[2]} = -\Phi^{[2]} + S_{zz}^{[2]} + \rho g h^{[2]} = 0 \quad \text{at } z=0,$$

and these, in turn, by using the first of (4.17) may be reduced to

$$w^{(2)} = S_{z\theta}^{(2)} = S_{rz}^{(2)} = 0 \quad \text{at } z=0 \tag{4.19b}$$

and

$$-\Phi^{(2)} + S_{zz}^{(2)} + \rho g h^{[2]} = 0 \quad \text{at } z=0. \tag{4.19c}$$

We also note that $w^{(2)}$, $S_{z\theta}^{(1)}$, and $S_{rz}^{(2)}$ are to vanish as $z \rightarrow -\infty$. The solution of (4.19a, b) is

$$\mathbf{u}^{(2)} = 0 \quad \text{and} \quad \Phi^{(2)} = \rho \left(A^2 r^2 + 4AB \log \frac{r}{b} - \frac{B^2}{r^2} \right) + C_2, \tag{4.20a, b}$$

where C_2 is a constant and, by use of (4.4), (4.12), and (4.15),

$$\mathbf{u}^{[2]} = \mathbf{u}^{(2)}, \quad \text{and} \quad \Phi^{[2]} = \Phi^{(2)}.$$

The second order correction coefficient $h^{[2]}$ is found from (4.19c) as

$$h^{[2]} = \frac{1}{\rho g} \Phi^{(2)}, \tag{4.20c}$$

and the constant C_2 is fixed by the condition (4.18g):

$$0 = \int_a^b r h^{[2]} dr = \frac{1}{\rho g} \left\{ \frac{C_2(b^2 - a^2)}{2} + \rho \int_a^b r \left(A^2 r^2 + 4AB \log \frac{r}{b} - \frac{B^2}{r^2} \right) dr \right\}$$

This completes the solution at second order.

* Thus, the n^{th} order contribution to the infinite perturbation series solution (4.5) in \mathcal{V}_Ω of any interior field quantity will, in general, depend on the particular domain mapping function ϕ which is chosen. However, since the full series obviates this dependence, as remarked earlier, it would appear that all quantities at each order n that involve this dependence may as well be dropped from consideration, *a priori*. This suggests that for any interior field \mathbf{u} , say, the right-hand side of (4.5) may be replaced by the equivalent sum $\sum_0^\infty \frac{1}{n!} \mathbf{u}^{(n)} \Omega^n$, where $\mathbf{u}^{(n)}$ is the solution of (4.18) in \mathcal{V}_0 , and where we simply replace the independent variables (r_0, z_0) of this solution directly with (r, z) , respectively. We shall investigate the correctness of this procedure in a later paper, and in light of its nature of plausibility, defer its application.

Before proceeding to the more involved perturbation problems at higher orders, we shall summarize the results obtained so far:

$$\begin{aligned}
 \mathbf{u} &= \Omega \left(Ar + \frac{B}{r} \right) \mathbf{e}_\theta + O(\Omega^3), \\
 \Phi &= p_a + \rho \frac{\Omega^2}{2} \left\{ A^2 r^2 + 4AB \log \frac{r}{b} - \frac{B^2}{r^2} - \frac{2}{(b^2 - a^2)} \right. \\
 &\quad \left. \cdot \int_a^b r \left(A^2 r^2 + 4AB \log \frac{r}{b} - \frac{B^2}{r^2} \right) dr \right\} + O(\Omega^4), \\
 h(r; \Omega) &= \frac{\Omega^2}{2g} \left\{ A^2 r^2 + 4AB \log \frac{r}{b} - \frac{B^2}{r^2} - \frac{2}{(b^2 - a^2)} \right. \\
 &\quad \left. \cdot \int_a^b r \left(A^2 r^2 + 4AB \log \frac{r}{b} - \frac{B^2}{r^2} \right) dr \right\} + O(\Omega^4).
 \end{aligned}$$

We remark that this solution reduces to that appropriate for the state of rigid rotation when $B=0$ (i.e., $\lambda=1$). Further, the symmetries of the perturbation from rest are such that Φ and h are necessarily even functions of Ω .

5. Generation of Secondary Motions

We recall that the first order solution has associated with it a non-zero shear stress component $S_{r\theta}^{(1)}$ given by

$$S_{r\theta}^{(1)} = \mu r \frac{\partial(v^{(1)}/r)}{\partial r} = \mu r \frac{\partial}{\partial r} (B/r^2) = -2\mu B/r^2.$$

Although this stress does not act on surfaces $z=\text{constant}$, it does contribute to the existence of non-equilibrated shear stress on the *deformed* free surface $h(r; \Omega)$ at order Ω^2 , and this unequilibrated traction is corrected at third order by the generation of a new circumferential velocity field which depends on z . The pressure field and free surface shape are unaltered at third order.

At third order ($n=3$) the fundamental field equations are

$$\rho [(\text{grad } \mathbf{u}) \mathbf{u}]^{(3)} = 0 = -\text{grad } \Phi^{(3)} + \mu \Delta \mathbf{u}^{(3)}, \quad \text{div } \mathbf{u}^{(3)} = 0 \quad \text{in } \mathcal{V}_0.$$

At the cylinder walls $r=a$ and $r=b$ we must satisfy $\mathbf{u}^{(3)}=0$. Because of axial symmetry, there is no circumferential pressure gradient, so that for single valued $\Phi^{(3)}$ we have

$$\frac{1}{r} \frac{\partial}{\partial r} \left(r \frac{\partial v^{(3)}}{\partial r} \right) + \frac{\partial^2 v^{(3)}}{\partial z^2} - \frac{v^{(3)}}{r^2} = 0 \quad \text{in } \mathcal{V}_0.$$

Using (4.18e, f, g) when $n=3$ and the second of equations (4.17), we find that

$$w^{(3)} = S_{rz}^{(3)} = S_{z\theta}^{(3)} - 3h^{[2]'} S_{r\theta}^{(1)} = 0 \quad \text{at } z=0 \tag{5.1}$$

and

$$h^{[3]} = (\Phi^{(3)} - S_{zz}^{(3)})/\rho g.$$

In addition, we may use (4.20 b, c) to rewrite the last of (5.1) as

$$\frac{\partial v^{(3)}}{\partial z} + \frac{12B}{gr^3} \left(Ar + \frac{B}{r} \right)^2 = 0. \tag{5.2}$$

Thus, the solution in \mathcal{V}_0 of the third order problem, which satisfies (4.18 g) with $n=3$ and which is such that $w^{(3)}$, $S_{rz}^{(3)}$, and $S_{z\theta}^{(3)}$ vanish as $z \rightarrow -\infty$, is given by

$$\begin{aligned} u^{(3)} = w^{(3)} = \Phi^{(3)} = S_{zz}^{(3)} = h^{[3]} = 0, \\ v^{(3)}(r, z) = \sum_{n=1}^{\infty} A_n e^{\lambda_n z} \mathcal{C}(\lambda_n r), \end{aligned} \tag{5.3a}$$

where $\mathcal{C}(\lambda_n r)$ denotes the cylinder functions

$$\mathcal{C}(\lambda_n r) \equiv J_1(\lambda_n a) Y_1(\lambda_n r) - J_1(\lambda_n r) Y_1(\lambda_n a), \tag{5.3b}$$

λ_n are the positive roots of

$$\mathcal{C}(\lambda_n b) = 0, \tag{5.3c}$$

and the A_n are Fourier-Bessel coefficients chosen so that (5.3) will satisfy (5.2). We observe, using (4.4) and the lower order solutions (4.12), (4.15), and (4.20), that in \mathcal{V}_0

$$u^{[3]} = u^{(3)} \quad \text{and} \quad \Phi^{[3]} = \Phi^{(3)}.$$

The dependence of the circumferential velocity upon z at third order appears at fourth order as a non-conservative body force which generates a general circulation as well as a further alteration of the pressure and the shape of the free surface.

At fourth order ($n=4$), we have

$$\begin{aligned} \rho [(\text{grad } \mathbf{u}) \mathbf{u}]^{(4)} = -8\rho v^{(1)} v^{(3)} \mathbf{e}_r / r = -\text{grad } \Phi^{(4)} + \mu \Delta \mathbf{u}^{(4)}, \\ \text{div } \mathbf{u}^{(4)} = 0 \quad \text{in } \mathcal{V}_0, \end{aligned} \tag{5.4a, b}$$

and the boundary conditions $\mathbf{u}^{(4)} = 0$ at $r=a$ and $r=b$. In addition, using (4.18 e) for $n=4$ and the third of equations (4.17), we find that

$$w^{(4)} = S_{z\theta}^{(4)} = S_{rz}^{(4)} = 0 \quad \text{at } z=0 \tag{5.4c, d, e}$$

and

$$-\Phi^{(4)} + S_{zz}^{(4)} + h^{[4]} \rho g = 0 \quad \text{at } z=0. \tag{5.4f}$$

Although it is clear that the solution of the fourth order problem, which is single valued and satisfies $w^{(4)} = S_{z\theta}^{(4)} = S_{rz}^{(4)} = 0$ at $z \rightarrow -\infty$, has $v^{(4)} = 0$ in \mathcal{V}_0 , the rest of the problem needs further explanation. Toward this end we note that since $v^{(4)} = 0$ in \mathcal{V}_0 , then

$$\text{curl } \mathbf{u}^{(4)} = \boldsymbol{\zeta} = e_\theta \zeta$$

and

$$\text{curl curl } \boldsymbol{\zeta} = -\Delta \boldsymbol{\zeta} = -\frac{e_\theta}{r} \mathcal{L}(r\zeta), \tag{5.5}$$

where we have defined

$$\mathcal{L} \equiv \frac{\partial^2}{\partial z^2} + \frac{\partial^2}{\partial r^2} - \frac{1}{r} \frac{\partial}{\partial r}$$

and

$$\zeta \equiv \frac{\partial u^{(4)}}{\partial z} - \frac{\partial w^{(4)}}{\partial r}.$$

Now, by introducing the stream function $\psi(r, z)$ such that

$$u^{(4)} = \frac{1}{r} \frac{\partial \psi}{\partial z}, \quad w^{(4)} = -\frac{1}{r} \frac{\partial \psi}{\partial r} \quad \text{in } \mathcal{V}_0,$$

we identically satisfy (5.4b) and further find that

$$\zeta = \frac{1}{r} \frac{\partial^2 \psi}{\partial z^2} + \frac{1}{r} \frac{\partial^2 \psi}{\partial r^2} - \frac{1}{r^2} \frac{\partial \psi}{\partial r} = \frac{1}{r} \mathcal{L}^2 \psi$$

and

$$\text{curl curl } \zeta = -\frac{e_\theta}{r} \mathcal{L}^2 \psi. \tag{5.6}$$

Thus, defining the scalar function $\gamma(r, z)$ through

$$\gamma \equiv -8\rho v^{(1)} v^{(3)}, \tag{5.7}$$

and forming the curl of (5.4a), we find using (5.5) and (5.6) that

$$\mu \mathcal{L}^2 \psi = \frac{\partial \gamma}{\partial z} \quad \text{in } \mathcal{V}_0. \tag{5.8a}$$

When the boundary conditions are transformed to the function ψ , we find that at the cylinder walls

$$\psi = \frac{\partial \psi}{\partial r} = 0 \quad \text{at } r=a \quad \text{and } r=b \tag{5.8b, c}$$

and that the free surface conditions (5.4c, e) become

$$\frac{\partial \psi}{\partial r} = \frac{\partial^2 \psi}{\partial z^2} - \frac{\partial^2 \psi}{\partial r^2} = 0 \quad \text{at } z=0. \tag{5.8d, e}$$

In addition, the surface height coefficient $h^{[4]}$ is determined from (5.4f), which may be written as

$$-\Phi - \frac{2\mu}{r} \frac{\partial^2 \psi}{\partial r \partial z} + \rho g h^{[4]} = 0 \quad \text{at } z=0, \tag{5.8f}$$

and the condition of constant volume (4.18g) with $n=4$. Finally, to complete the characterization of the problem at fourth order, we add the conditions at infinity,

$$\frac{\partial \psi}{\partial r} = \frac{\partial^2 \psi}{\partial z^2} - \frac{\partial^2 \psi}{\partial r^2} = 0 \quad \text{as } z \rightarrow -\infty.$$

Using (4.3) and the symmetry of the domain mapping function, we verify that $V_\Omega = 0$ when $\Omega = 0$; then from (4.4) we have

$$(\cdot)^{(4)} = (\cdot)^{[4]}. \tag{5.9}$$

The solution $\psi(r, z)$ to (5.8) gives rise to a cross flow in planes $\theta = \text{constant}$; thus, at fourth order, the fluid begins to circulate up and down along the axial direction and in and out along radial lines.

We close this section with a brief examination of the perturbation problems at arbitrary order. We noted in the Introduction that symmetry of the problem with respect to a change in the sign of Ω requires that

$$v^{(2m)} = p^{(2m+1)} = h^{[2m+1]} = u^{(2m+1)} = w^{(2m+1)} = 0.$$

To prove this, assume that it is true when $m < n$. Then (4.18) shows that this must be true when $m = n$. Inspection of (4.18) also shows that the operators to be inverted when n is odd are those which appear at third order, and when n is even the operators which are to be inverted are just those which appear first at fourth order. Of course the inhomogeneous terms change with index but the unique invertibility of the operators for arbitrary inhomogenities is easy to establish. The inversion in the odd order problem in Fourier-Bessel series hardly needs explanation. It follows that the inverse operator defined at the fourth order is the key to the explicit resolution of the problem at all orders. This fourth order problem is most easily solved when the gap $(b - a)/(b + a)$ is small, and we shall consider this simpler problem in the next section.

6. Secondary Flow When the Gap Is Small

Let $\bar{r} = (a + b)/2$ be the mean radius, and let $2\delta = b - a$ be the gap. We shall simplify the calculations by treating the problem when the gap size δ/\bar{r} is sufficiently small*. Introducing the variable $y, r = \bar{r} + y$ where $-\delta \leq y \leq \delta$, when $\delta/\bar{r} \rightarrow 0$ we write

$$\text{grad} = e_y \frac{\partial}{\partial y} + e_z \frac{\partial}{\partial z}, \quad \Delta = \frac{\partial^2}{\partial y^2} + \frac{\partial^2}{\partial z^2}, \quad \text{etc.} \tag{6.1a}$$

and

$$F + G y = A r + \frac{B}{r}, \tag{6.1b}$$

where

$$F = A \bar{r} + \frac{B}{\bar{r}},$$

and

$$G \equiv A - B/\bar{r}^2.$$

The solution at third order may be simplified. Replacing (5.2) and (5.3), we get

$$\frac{\partial v^{(3)}}{\partial z} = -\frac{12B}{g\bar{r}^3} (F + G y)^2 \tag{6.2a}$$

and

$$v^{(3)} = \sum_{n=0} A_n e^{k_n z} \cos k_n y + \sum_{m=1} B_m e^{j_m z} \sin j_m y, \tag{6.2b}$$

* In many other problems in which the narrow gap approximation is used the approximation and the exact solution are often in reasonable agreement when $2\delta/\bar{r} < \frac{1}{2}$.

where for $n=0, 1, \dots$, and $m=1, 2, \dots$,

$$k_n = (2n + 1)\pi/2\delta, \quad j_m = m\pi/\delta,$$

$$A_n = \frac{-96B(-1)^n\delta}{g\bar{r}^3(2n+1)^2\pi^2} \left\{ F^2 + \delta^2 G^2 \left(1 - \frac{8}{(2n+1)^2\pi^2} \right) \right\},$$

and

$$B_m = \frac{48B(-1)^m\delta^2 FG}{g\bar{r}^3 m^2 \pi^2}.$$

The approximation of (5.4a) for small gaps is

$$e_y \frac{\gamma(y, z)}{\bar{r}} = -\text{grad } \Phi^{(4)} + \mu \Delta u^{(4)} \quad \text{in } \mathcal{V}_0, \tag{6.3}$$

where grad and Δ are as in (6.1a), and

$$\gamma = -8\rho v^{(1)}v^{(3)} = -8\rho(F + Gy) \left\{ \sum_{n=0} A_n e^{k_n z} \cos k_n y + \sum_{m=1} B_m e^{j_m z} \sin j_m y \right\}. \tag{6.4}$$

To obtain $u^{(4)}$ that satisfies (5.4b), we introduce the stream function $\hat{\psi}(y, z) = \psi(r, z)$, where

$$\bar{r} u^{(4)} = \frac{\partial \hat{\psi}}{\partial z}, \quad \bar{r} w^{(4)} = -\frac{\partial \hat{\psi}}{\partial y}. \tag{6.5}$$

The following boundary value problem for $\hat{\psi}$ is obtained as in (5.8):

$$\frac{\partial \gamma}{\partial z} = \mu \Delta^2 \hat{\psi} \quad \text{in } \mathcal{V}_0, \quad \hat{\psi} = \frac{\partial \hat{\psi}}{\partial y} = 0|_{y=\pm\delta}, \quad \hat{\psi} \rightarrow 0|_{z \rightarrow -\infty}, \tag{6.6a, b, c}$$

where $\Delta^2(\cdot) = \Delta\Delta(\cdot)$, and

$$\frac{\partial \hat{\psi}}{\partial y} = \frac{\partial^2 \hat{\psi}}{\partial z^2} - \frac{\partial^2 \hat{\psi}}{\partial y^2} = 0|_{z=0}.$$

Since $\partial \hat{\psi} / \partial y = 0|_{z=0}$ is an identity in y , we may replace these latter conditions with the conditions (6.6d, e) below:

$$\frac{\partial \hat{\psi}}{\partial y} = \frac{\partial^2 \hat{\psi}}{\partial z^2} = 0|_{z=0}. \tag{6.6d, e}$$

Given $\hat{\psi}(y, z)$, we may determine $\Phi^{(4)}$ by integrating the z component of (6.3). Thus defining $\Gamma(y, z)$ through

$$\frac{\partial \Gamma}{\partial z} = \hat{\psi} \tag{6.7}$$

and using (6.5), we may write

$$\Phi^{(4)} + \frac{\mu}{\bar{r}} \Delta \frac{\partial \Gamma}{\partial y} = 0. \tag{6.8}$$

To determine the fourth order correction coefficient $h^{[4]}$, we first note that in the approximation for narrow gaps we must replace (5.8f) with

$$-\Phi^{(4)} - \frac{2\mu}{\bar{r}} \frac{\partial^2 \hat{\psi}}{\partial z \partial y} + \rho g h^{[4]} = 0|_{z=0}.$$

This combines with (6.8) to give

$$h^{[4]} = \frac{\mu}{\rho g \bar{r}} \left\{ \frac{\partial^3 \Gamma}{\partial z^2 \partial y} - \frac{\partial^3 \Gamma}{\partial y^3} \right\} \Big|_{z=0}. \quad (6.9)$$

The problem (6.6) is at the edge of tractability. It may, however, be solved exactly by reducing it to a variant of an elasticity problem solved by SMITH [15]. To do this we shall first reduce (6.6) to the semi-infinite strip problem (6.11) below. Setting

$$\hat{\psi} = \frac{\rho}{\mu} (\Psi + \Theta) \quad \text{in } \mathcal{V}_0,$$

where Ψ is a solution of (6.6 a, b, c), but not necessarily of (6.6 d, e), we see that

$$\Delta^2 \Theta = 0 \quad \text{in } \mathcal{V}_0, \quad \Theta = \frac{\partial \Theta}{\partial y} = 0 \Big|_{y=\pm\delta}, \quad \Theta \rightarrow 0 \Big|_{z \rightarrow -\infty}, \quad (6.11a, b, c)$$

and

$$\frac{\partial}{\partial y} (\Theta + \Psi) = \frac{\partial^2}{\partial z^2} (\Theta + \Psi) = 0 \Big|_{z=0}. \quad (6.11 d, e)$$

The problem (6.11) has been studied by SMITH [15]. His results are expressed in the variables

$$t \equiv \frac{y}{\delta} \quad \text{and} \quad x \equiv -\frac{z}{\delta}, \quad (6.12)$$

and he gives an algorithm for calculating the "Fourier" coefficients of the Papkovitch-Fadle series which formally solve the following biharmonic semi-infinite strip problem in the domain $-1 < t < 1$, $0 < x < \infty$:

$$\frac{\partial^4 \Theta}{\partial t^4} + 2 \frac{\partial^4 \Theta}{\partial t^2 \partial x^2} + \frac{\partial^4 \Theta}{\partial x^4} = 0, \quad \Theta = \frac{\partial \Theta}{\partial t} = 0 \Big|_{t=\pm 1}, \quad \Theta \rightarrow 0 \Big|_{x \rightarrow \infty},$$

and

$$\frac{\partial^2 \Theta}{\partial x^2} = f(t), \quad \frac{\partial^2 \Theta}{\partial t^2} = g(t) \quad \text{at } x=0. \quad (6.13 a, b, c, d, e)$$

In his work, the given edge data $g(t)$ is required to satisfy the consistency conditions

$$\int_{-1}^1 g dt = \int_{-1}^1 t g dt = 0, \quad (6.14)$$

with the side wall boundary data (6.13 b). The consistency conditions hold for our problem (6.11). SMITH also proves the convergence of his series under very restrictive conditions on the data $f(t)$ and $g(t)$ which do *not* hold for (6.11 d, e). However, we shall find explicit representations for the coefficients (C_{1in} in (6.22) and (6.24)) in the series solution which allow us to prove the convergence of our series.

To carry out the calculation of SMITH's solution of our problem, we must first reduce the problem (6.6) to the problem (6.11). The required solution of

(6.6a, b, c) may be composed as follows:

$$\Psi = \sum_{i=1}^4 \sum_{n=0}^{\infty} A_{in} \Psi_{in}(y, z), \tag{6.15}$$

where for $n=0, 1, 2, \dots$, and for $B_0 \equiv 0$,

$$\begin{aligned} A_{1n} &= -8FA_n k_n, & \Psi_{1n} &= e^{k_n z} \chi_{1n}(y), \\ A_{2n} &= -8GB_n j_n, & \Psi_{2n} &= e^{j_n z} \chi_{2n}(y), \\ A_{3n} &= -8GA_n k_n, & \Psi_{3n} &= e^{k_n z} \chi_{3n}(y), \\ A_{4n} &= -8FB_n j_n, & \Psi_{4n} &= e^{j_n z} \chi_{4n}(y), \end{aligned}$$

$$\Theta = - \sum_{i=1}^4 \sum_{n=0}^{\infty} A_{in} \Theta_{in}(y, z), \tag{6.16}$$

where $\Theta_{in}(y, z)$ and $\chi_{in}(y)$ are to be determined. In fact, returning with $\hat{\psi} = \frac{\rho}{\mu}(\Psi + \Theta)$ to (6.6), we see that

$$J_n i \chi_{in} = q_{in}, \quad \chi_{in} = \chi'_{in} = 0|_{y=\pm\delta}, \tag{6.17 a, b}$$

where

$$J_{n1} = J_{n3} = \frac{d^4}{dy^4} + 2k_n^2 \frac{d^2}{dy^2} + k_n^4,$$

$$J_{n2} = J_{n4} = \frac{d^4}{dy^4} + 2j_n^2 \frac{d^2}{dy^2} + j_n^4,$$

$$q_{1n} = \cos k_n y,$$

$$q_{2n} = y \sin j_n y,$$

$$q_{3n} = y \cos k_n y,$$

$$q_{4n} = \sin j_n y,$$

and

$$\Delta^2 \Theta_{in} = 0, \quad \Theta_{in} = \frac{\partial \Theta_{in}}{\partial y} = 0|_{y=\pm\delta}, \quad \Theta_{in} \rightarrow 0|_{z \rightarrow -\infty},$$

$$\frac{\partial^2 \Theta_{in}}{\partial z^2} = \frac{\partial^2 \Psi_{in}}{\partial z^2} \quad \text{and} \quad \frac{\partial^2 \Theta_{in}}{\partial y^2} = \frac{\partial^2 \Theta_{in}}{\partial y^2} \quad \text{at} \quad z=0. \tag{6.18 a, b, c, d, e}$$

The solution of (6.17a, b) is given by

$$\begin{aligned} \chi_{1n}(y, k_n, \delta) &= -\frac{1}{8k_n^2} (y^2 - \delta^2) \cos k_n y, \\ \chi_{2n}(y, j_n, \delta) &= \frac{-1}{24j_n^2} \left\{ y \left(y^2 - \delta^2 - \frac{6}{j_n^2} \right) \sin j_n y + \frac{3}{j_n} (y^2 - \delta^2) \cos j_n y \right\}, \\ \chi_{3n}(y, k_n, \delta) &= \frac{-1}{24k_n^2} \left\{ y \left(y^2 - \delta^2 - \frac{6}{k_n^2} \right) \cos k_n y + \frac{3}{k_n} (y^2 - \delta^2) \sin k_n y \right\}, \\ \chi_{4n}(y, j_n, \delta) &= -\frac{1}{8j_n^2} (y^2 - \delta^2) \sin j_n y, \\ \chi_{20} &= \chi_{40} = 0. \end{aligned} \tag{6.17b}$$

To complete the solution in the form

$$\hat{\psi} = \frac{\rho}{\mu} \sum_{i=1}^4 \sum_{n=0}^{\infty} A_{in} (\Psi_{in} - \Theta_{in}), \tag{6.19}$$

we must find the solution of (6.18). To use SMITH's solution, we change variables as in (6.12) and scale the wave numbers according to

$$k_n = \gamma_n / \delta, \quad j_n = \mu_n / \delta.$$

Then, in the new variables $-1 < t < 1, 0 < x < \infty$, we must solve

$$\Delta^2 \Theta_{in} = 0, \quad \Theta_{in} = \frac{\partial \Theta_{in}}{\partial t} = 0|_{t=\pm 1}, \quad \Theta_{in} \rightarrow 0|_{x \rightarrow \infty}, \tag{6.20a, b, c}$$

with

$$\frac{\partial^2 \Theta_{in}}{\partial x^2} = f_{in}, \quad \frac{\partial^2 \Theta_{in}}{\partial t^2} = g_{in} \quad \text{at } x=0, \tag{6.20d, e}$$

where

$$f_{in} \equiv -\frac{\partial^2 \Psi_{in}}{\partial x^2}, \quad g_{in} \equiv \frac{\partial^2 \Psi_{in}}{\partial t^2} \quad \text{at } x=0. \tag{6.20f}$$

Here we use the notation

$$\begin{aligned} \Psi_{1n} &= e^{-\gamma_n x} \hat{\chi}_{1n}, & \hat{\chi}_{1n} &\equiv \delta^4 \chi_{1n}(t, \gamma_n, 1), \\ \Psi_{2n} &= e^{-\mu_n x} \hat{\chi}_{2n}, & \hat{\chi}_{2n} &\equiv \delta^5 \chi_{2n}(t, \mu_n, 1), \\ \Psi_{3n} &= e^{-\gamma_n x} \hat{\chi}_{3n}, & \hat{\chi}_{3n} &\equiv \delta^5 \chi_{3n}(t, \gamma_n, 1), \\ \Psi_{4n} &= e^{-\mu_n x} \hat{\chi}_{4n}, & \hat{\chi}_{4n} &\equiv \delta^4 \chi_{4n}(t, \mu_n, 1). \end{aligned} \tag{6.21}$$

With these preliminaries aside we may now form SMITH's solution of (6.20). It is convenient to introduce superscripts *e* and *o* which designate functions which are even or odd in the variable *t*. In the problem (6.20) the functions with *i* = 1, 2 are even in *t* and the ones with *i* = 3, 4 are odd functions of *t*. For even data $f=f^e, g=g^e$, SMITH's solutions are in the form

$$\begin{Bmatrix} \Theta_{1n} \\ \Theta_{2n} \end{Bmatrix} = \text{Re} \sum_{i=1}^2 \frac{1}{S_i^2} \begin{Bmatrix} C_{i1n} \\ C_{i2n} \end{Bmatrix} \Theta_i^e(t) e^{-S_i x}, \tag{6.22}$$

where Re means real part, the S_i are the first quadrant complex roots of the equation

$$2S_i + \sin 2S_i = 0, \tag{6.23a}$$

and

$$\Theta_i^e = S_i \sin S_i \cos S_i t - S_i t \cos S_i \sin S_i t. \tag{6.23b}$$

The "Fourier" coefficients of the Papkovich-Fadle series (6.22) are given by SMITH as

$$d_{iin} \equiv -4 \cos^4 S_i C_{iin} = \langle -g_{in} \tilde{\Theta}_i^e + \Theta_i^e (f_{in} + 2g_{in}) \rangle \quad (i=1, 2), \tag{6.23c}$$

where

$$\langle \cdot \rangle \equiv \int_{-1}^1 (\cdot) dt,$$

$$\tilde{\Theta}_i^e \equiv \Theta_i^e - 2 \cos S_i \cos S_i t, \tag{6.23d}$$

and

$$\frac{d^2 \tilde{\Theta}_i^e}{dt^2} = -S_i^2 \Theta_i^e. \tag{6.23e}$$

For the odd data we have

$$\begin{Bmatrix} \Theta_{3n} \\ \Theta_{4n} \end{Bmatrix} = \text{Re} \sum_{l=1}^1 \frac{1}{P_l^2} \begin{Bmatrix} C_{l3n} \\ C_{l4n} \end{Bmatrix} \Theta_i^o(t) e^{-P_l x}, \tag{6.24}$$

where the P_l are the first quadrant complex roots of the equation

$$2P_l - \sin 2P_l = 0, \tag{6.25a}$$

and

$$\Theta_i^o = P_l \cos P_l \sin P_l t - P_l t \sin P_l \cos P_l t. \tag{6.25b}$$

Here, the ‘‘Fourier’’ coefficients are given by

$$d_{iin} \equiv -4 \sin^4 P_l C_{lin} = [-g_{in} \tilde{\Theta}_i^o + \Theta_i^o (f_{in} + 2g_{in})] \quad (i=3, 4), \tag{6.25c}$$

where

$$\tilde{\Theta}_i^o = \Theta_i^o + 2 \sin P_l \sin P_l t, \tag{6.25d}$$

and

$$\frac{d^2 \tilde{\Theta}_i^o}{dt^2} = -P_l^2 \Theta_i^o. \tag{6.25e}$$

The calculation of the coefficients d_{iin} may be simplified in the following way. After (6.20 f), let $g = \partial^2 \Psi / \partial t^2$ and $f = \partial^2 \Psi / \partial x^2 = \gamma^2 \Psi$ at $x=0$, where we have temporarily dropped the subscripts. Recalling that $\Psi = d\Psi/dt = 0$ at $t = \pm 1$ and referring to (6.23 c), we find

$$\begin{aligned} d_{iin} &= \left\langle -\frac{d^2 \Psi}{dt^2} \tilde{\Theta}_i^o + \left(\gamma^2 \Psi + 2 \frac{d^2 \Psi}{dt^2} \right) \Theta_i^e \right\rangle \\ &= \left\langle -\Psi \frac{d^2 \tilde{\Theta}_i^o}{dt^2} + \gamma^2 \Psi \Theta_i^e + 2\Psi \frac{d^2 \Theta_i^e}{dt^2} \right\rangle. \end{aligned}$$

Now, using (6.23 c, d, e) and (6.21) with $x=0$, we get

$$d_{iin} = (\gamma^2 - S_i^2) \langle \hat{\chi}_{in} \Theta_i^e \rangle - 4S_i^2 \cos S_i \langle \hat{\chi}_{in} \cos S_i t \rangle, \tag{6.26}$$

where $i=(1, 2)$, and where $\gamma^2 = \gamma_n^2$ or μ_n^2 depending on whether $i=1$ or 2. In the same way we find

$$d_{iin} = (\mu^2 - P_l^2) \langle \hat{\chi}_{in} \Theta_i^o \rangle + 4P_l^2 \sin P_l \langle \hat{\chi}_{in} \sin P_l t \rangle, \tag{6.27}$$

where $i=(3, 4)$, and where $\mu^2 = \gamma_n^2$ or μ_n^2 depending on whether $i=3$ or 4. The functions $\hat{\chi}_{in}$ are defined by (6.21) and (6.17 c).

To shorten the writing we may suppress the subscripts l and n : $d_{iin} = d_i$, $\hat{\chi}_{in} = \hat{\chi}_i$, $P_l^2 = P^2$, etc. Inserting (6.23 b) into (6.26) and (6.25 b) in (6.27), and using

(6.23a) and (6.25a), we get

$$\begin{aligned} \frac{d_1 \sin S}{S} &= F_1(\gamma, S, \sin^2 S) I_1 + F_2(\gamma, S) I_{1,s} = -\frac{d_1}{\cos S}, \\ \frac{d_2 \sin S}{S} &= F_1(\mu, S, \sin^2 S) I_2 + F_2(\mu, S) I_{2,s} = -\frac{d_2}{\cos S}, \\ \frac{d_3 \cos P}{P} &= H_1(\gamma, P, \cos^2 P) I_3 + H_2(\gamma, P) I_{3,P} = \frac{d_3}{\sin P}, \\ \frac{d_4 \cos P}{P} &= H_1(\mu, P, \cos^2 P) I_4 + H_2(\mu, P) I_{4,P} = \frac{d_4}{\sin P}, \end{aligned} \quad (6.28a, b, c, d)$$

where we have defined

$$\begin{aligned} I_i &\equiv \langle \hat{\chi}_i \cos St \rangle \quad (i=1, 2), \\ I_i &\equiv \langle \hat{\chi}_i \sin Pt \rangle \quad (i=3, 4), \\ I_{1,s} &\equiv \frac{\partial I_1}{\partial S} \quad \text{etc.} \end{aligned} \quad (6.29)$$

In these equations we have also used the following definitions:

$$\begin{aligned} (\gamma^2 - S^2) \sin^2 S - 4S \cos S \sin S &= (\gamma^2 - S^2) \sin^2 S + 4S^2 \\ &\equiv F_1(\gamma, S, \sin^2 S), \\ (\gamma^2 - P^2) \cos^2 P + 4P \sin P \cos P &= (\gamma^2 - P^2) \cos^2 P + 4P^2 \\ &\equiv H_1(\gamma, P, \cos^2 P), \\ (\gamma^2 - S^2) \cos S \sin S &= -S(\gamma^2 - S^2) \equiv F_2(\gamma, S), \\ -(\gamma^2 - P^2) \cos P \sin P &= -P(\gamma^2 - P^2) \equiv H_2(\gamma, P). \end{aligned} \quad (6.30a, b, c, d)$$

Equations (6.30) show that

$$F_1(\cdot, \cdot, \cdot) = H_1(\cdot, \cdot, \cdot), \quad F_2(\cdot, \cdot) = H_2(\cdot, \cdot).$$

We may further simplify (6.28) by introducing the functions

$$\begin{aligned} J(\alpha, S) &\equiv \langle \cos \alpha t \cos St \rangle \\ &= \frac{2\alpha}{\alpha^2 - S^2} \sin \alpha \cos S - \frac{2S}{\alpha^2 - S^2} \cos \alpha \sin S, \\ K(\alpha, S) &\equiv \langle \sin \alpha t \sin St \rangle \\ &= \frac{2S}{\alpha^2 - S^2} \sin \alpha \cos S - \frac{2\alpha}{\alpha^2 - S^2} \cos \alpha \sin S. \end{aligned} \quad (6.31a, b)$$

To complete the calculations of the d_i given by (6.28) we must evaluate (6.29) with $\hat{\chi}_i = \hat{\chi}_{i,n}$ defined by (6.21) and (6.17c). We find that

$$\frac{8\gamma^2}{\delta^4} I_1 = J_{,\gamma\gamma} + J,$$

$$\frac{24\mu^2}{\delta^5} I_2 = -J_{,\mu\mu\mu} - \left(1 + \frac{6}{\mu^2}\right) J_{,\mu} + \frac{3}{\mu} (J_{,\mu\mu} + J),$$

$$\frac{24\gamma^2}{\delta^5} I_3 = K_{,\gamma\gamma\gamma} + \left(1 + \frac{6}{\mu^2}\right) K_{,\gamma} - \frac{3}{\gamma} (K_{,\gamma\gamma} + K),$$

and

$$\frac{8\mu^2}{\delta^4} I_4 = K_{,\mu\mu} + K, \tag{6.32a, b, c, d}$$

where a comma followed by a subscript denotes differentiation with respect to the first argument in J and K . In addition, (6.32a, c) are evaluated at $\alpha = \gamma = \gamma_n = (2n + 1)\pi/2$, and (6.32b, d) are evaluated at $\alpha = \mu = \mu_n = n\pi$. Thus, I_i ($i = 1, 2, 3, 4$) are determined by differentiation of (6.31) as prescribed by (6.32); the constants $d_i = d_{i i n}$ may be found from (6.28), and $C_{i i n}$ follow from the definitions (6.23c) and (6.25c). A straightforward but tedious calculations yields the following:

$$C_{11n} = -\frac{(-1)^n \gamma_n S_i^2 \delta^4}{(\gamma_n^2 - S_i^2)^3 \cos^2 S_i}, \tag{6.33a}$$

$$C_{12n} = \frac{(-1)^n S_i^2 \mu_n \delta^5}{(\mu_n^2 - S_i^2)^4 \cos^4 S_i} \{(\mu_n^2 - S_i^2) \cos^2 S_i - 4S_i^2\}, \tag{6.33b}$$

$$C_{13n} = \frac{(-1)^n P_i^2 \gamma_n \delta^5}{(\gamma_n^2 - P_i^2)^4 \sin^4 P_i} \{(\gamma_n^2 - P_i^2) \sin^2 P_i - 4P_i^2\}, \tag{6.33c}$$

and

$$C_{14n} = -\frac{(-1)^n \mu_n P_i^2 \delta^4}{(\mu_n^2 - P_i^2)^3 \sin^2 P_i}. \tag{6.33d}$$

With the expressions (6.33) we have completed the solutions of (6.19) in the form of Papkovitch-Fadle series (6.22) and (6.24). We next consider the convergence of these series.

The values of S_i (6.23a) and P_i (6.25a) have been given by ROBBINS & SMITH [12] and HILLMAN & SALZER [6], respectively. Asymptotic values for large l ($= 1, 2 \dots$) are of the forms

$$2S_i = (2l - \frac{1}{2})\pi + i \log(4l - 1)\pi$$

(6.34)

and

$$2P_i = (2l - \frac{3}{2})\pi + i \log(4l - 3)\pi.$$

These asymptotic formulas are already good approximations when $l > 2$ and good to eight figures when $l > 10$. To leading order ($0 \leq t \leq 1$),

$$\sin S_i t = \frac{i}{2} [(4l - 1)\pi]^{\frac{t}{2}} e^{-i(t-1/4)\pi t} + O(l^{-\frac{t}{2}}),$$

$$\sin P_i t = \frac{i}{2} [(4l - 3)\pi]^{\frac{t}{2}} e^{-i(t-3/4)\pi t} + O(l^{-\frac{t}{2}}),$$

$$\cos S_1 t = \frac{1}{2} [(4l-1)\pi]^{\frac{t}{2}} e^{-i(l-1/4)\pi t} + O(l^{-\frac{t}{2}}),$$

(6.35)

and

$$\cos P_1 t = \frac{1}{2} [(4l-3)\pi]^{\frac{t}{2}} e^{-i(l-3/4)\pi t} + O(l^{-\frac{t}{2}}).$$

Hence, we find that for large l ,

$$|C_{lin}| < \frac{K_{in}}{l^5},$$

where the K_{in} are constants independent of l . To leading order it follows from (6.23b) and (6.25b) that

$$\Theta_i^e(t) = O(l^2), \quad \Theta_i^o(t) = O(l^2)$$

at large l . Therefore the series (6.22) and (6.24) may be dominated term by term by K/l^5 for some constant K . The series (6.22) and (6.24) are therefore absolutely convergent, uniformly in t .

The situation in regard to convergence of the series for the free surface correction coefficient $h^{[4]}(y)$ appears less salubrious because of the three derivatives required in (6.9). However, these differentiated series do converge. To show convergence, we first define

$$\Gamma_{in} \equiv \delta \operatorname{Re} \sum_{i=1} C_{lin} \begin{cases} \frac{1}{S_i^3} \Theta_i^e(y/\delta) e^{\frac{S_i z}{\delta}} & (i=1, 2), \\ \frac{1}{P_i^3} \Theta_i^o(y/\delta) e^{\frac{P_i z}{\delta}} & (i=3, 4), \end{cases} \tag{6.36}$$

and

$$\begin{aligned} \hat{A}_{1n} &\equiv -8FA_n, & \hat{A}_{2n} &\equiv -8GB_n, \\ \hat{A}_{3n} &\equiv -8GA_n, & \hat{A}_{4n} &\equiv -8FB_n, \end{aligned} \tag{6.37}$$

and observe, with the aid of (6.15), (6.22) and (6.24), that $\hat{\psi}$ in (6.19) may be written as

$$\hat{\psi} = \frac{\partial \Gamma}{\partial z}, \tag{6.38a}$$

where

$$\Gamma \equiv \frac{\rho}{\mu} \sum_{i=1}^4 \sum_{n=0}^{\infty} (\hat{A}_{in} \Psi_{in} - A_{in} \Gamma_{in}). \tag{6.38b}$$

Thus, Γ satisfies (6.7), and with (6.9) we have

$$\begin{aligned} h^{[4]} = \frac{1}{g\bar{r}} \sum_{i=1}^4 \sum_{n=0}^{\infty} \left\{ \hat{A}_{in} \left(\frac{\partial^3}{\partial z^2 \partial y} - \frac{\partial^3}{\partial y^3} \right) \Psi_{in} \right. \\ \left. - A_{in} \left(\frac{\partial^3}{\partial z^2 \partial y} - \frac{\partial^3}{\partial y^3} \right) \Gamma_{in} \right\} \Big|_{z=0}. \end{aligned} \tag{6.39}$$

Using (6.36), we now show that the formal series for $\left(\frac{\partial^3}{\partial z^2 \partial y} - \frac{\partial^3}{\partial y^3} \right) \Gamma_{in}$ at $z=0$ is absolutely and uniformly convergent for $-\delta \leq y \leq \delta$. Toward this end,

we observe, using (6.23b) and (6.25b), that

$$\left(\frac{\partial^3}{\partial z^2 \partial y} - \frac{\partial^3}{\partial y^3} \right) \left\{ \begin{array}{l} \frac{1}{S_l^3} \Theta_l^e(y/\delta) e^{\frac{S_l z}{\delta}} \\ \frac{1}{P_l^3} \Theta_l^o(y/\delta) e^{\frac{P_l z}{\delta}} \end{array} \right\} \Bigg|_{z=0} \tag{6.40}$$

$$= \frac{2}{\delta^3} \left\{ \begin{array}{l} -S_l \sin S_l \sin S_l \frac{y}{\delta} - 2 \cos S_l \sin S_l \frac{y}{\delta} - S_l \frac{y}{\delta} \cos S_l \cos S_l \frac{y}{\delta} \\ P_l \cos P_l \cos P_l \frac{y}{\delta} - 2 \sin P_l \cos P_l \frac{y}{\delta} + P_l \frac{y}{\delta} \sin P_l \sin P_l \frac{y}{\delta} \end{array} \right\}.$$

Thus, for each fixed $y \in [-\delta, \delta]$ it follows from (6.34) and (6.35) that the magnitude of the right-hand side of (6.40) is $O(l^{\frac{3+|y/\delta|}{2}})$ for sufficiently large integer l . Since we concluded earlier that $|C_{lin}| = O(l^{-5})$, it follows that the magnitude of the l^{th} term in either of the series for $\left(\frac{\partial^3}{\partial z^2 \partial y} - \frac{\partial^3}{\partial y^3} \right) \Gamma_{in}$ at $z=0$ as formally calculated from (6.36) is $O(l^{\frac{|y/\delta|-7}{2}})$. Thus, these series may be dominated by terms of the form Kl^{-3} , where K is independent of l and y . Whence the absolute and uniform convergence of the formal series for $\left(\frac{\partial^3}{\partial z^2 \partial y} - \frac{\partial^3}{\partial y^3} \right) \Gamma_{in}$ at $z=0$ in $-\delta \leq y \leq \delta$ is established. We remark in passing that while the series is rapidly convergent for any $y \in [-\delta, \delta]$, we get faster convergence when $y = |\delta|$. In this case, (6.23a) and (6.25a) show that the right-hand side of (6.40) may be replaced with

$$\frac{2}{\delta^3} \left\{ \begin{array}{l} \pm S_l \\ -P_l \end{array} \right\}, \quad y = \pm \delta.$$

Thus, with (6.34), we see that at $y = |\delta|$ the magnitude of the right-hand side of (6.40) is $O(l)$, and with the earlier result that $|C_{lin}| = O(l^{-5})$ we conclude with the aid of (6.36) that the formal series for $\left(\frac{\partial^3}{\partial z^2 \partial y} - \frac{\partial^3}{\partial y^3} \right) \Gamma_{in}$ at $z=0, y = |\delta|$, may be dominated by terms of the form Kl^{-4} , where K is independent of l .

We now consider the convergence of (6.39). Due to the fact that $A_{in} \sim \frac{(-1)^n}{n}$ from (6.15) and (6.2b), and that $C_{lin} \sim \frac{1}{n^5}$ from (6.33), it readily follows that the series involving the coefficients A_{in} in (6.39) converges. Turning next to the series with the coefficients \hat{A}_{in} , we note from (6.37) and (6.2b) that $A_{in} \sim \frac{(-1)^n}{n^2}$. Using (6.15) and (6.17c), we show that $\left(\frac{\partial^3}{\partial z^2 \partial y} - \frac{\partial^3}{\partial y^3} \right) \Psi_{in}|_{z=0} \sim n$. Thus, the series in (6.39) which involves the coefficients \hat{A}_{in} is conditionally convergent, and we have shown the convergence of the series representation for $h^{[4]}$.

The convergence of our series solution in the interior is very rapid; it may, in fact, be regarded as a solution of the ‘‘Saint Venant’’ type. The four decay factors

for the solution are of the form

$$\begin{aligned}
 e^{k_n z}, & \quad k_n = (2n + 1)\pi/2\delta & (n = 0, 1, 2 \dots), \\
 e^{j_n z}, & \quad j_n = n\pi/\delta & (n = 1, 2, \dots), \\
 e^{S_1 z/\delta}, & \quad S_1 = 2.106 + i2.106, & S_2 = 5.356 + i1.1552,
 \end{aligned}$$

and

$$e^{P_1 z/\delta}, \quad P_1 = 3.749 + i1.384, \quad P_2 = 6.950 + i1.676.$$

As z is decreased the entire solution decays exponentially. The most persistent part of the remaining solution is the part containing the smallest decay factor $e^{k_0 z}$ as a factor. It follows that the solution (6.19), or equivalently (6.38), decays rapidly to

$$\hat{\psi} = \frac{\rho}{\mu} A_{10} \Psi_{10}$$

as z is decreased through a distance of order δ .

Chapter II. The Free Surface on a Simple Fluid

7. Characterization of the Problem for Non-Newtonian Fluids

The general problem to be studied in this chapter of the paper is characterized as follows: given a simple fluid with fading memory whose constitutive assumption for the extra stress S satisfies (2.6), find the fields $h(\cdot)$, $u(\cdot)$, $p(\cdot)$ and $S(\cdot)$ in \mathcal{V}_Ω such that the field equations (2.4 a, b), are satisfied subject to the condition of constant volume (2.1 e) and the boundary conditions (2.4 c, d, e, f, g). As in the earlier work with Newtonian liquids (Sections 4–6), we shall develop the solution in a perturbation series in powers of Ω . In order to carry out this construction, we shall draw upon the approximation theorem of COLEMAN & NOLL for retarded motions in materials with fading memory. A discussion of this theorem and its relation to the present study has already been given in Section 2.

To simplify our calculations, it is useful to introduce a notation which takes advantage of the axial symmetry of the problem. Thus, we define the "plane" gradient operator ∇ through

$$\nabla(\cdot) \equiv \frac{\partial(\cdot)}{\partial r} \otimes e_r + \frac{\partial(\cdot)}{\partial z} \otimes e_z, \tag{7.1 a}$$

where \otimes denotes the dyadic product, and let $\nabla \cdot$ denote the "plane" divergence operator based on this definition. The full gradient then has the form

$$\text{grad}(\cdot) = \nabla(\cdot) + \frac{1}{r} \frac{\partial(\cdot)}{\partial \theta} \otimes e_\theta. \tag{7.1 b}$$

It is also useful to decompose the velocity $u(\cdot)$ with physical components (u, v, w) as follows:

$$u \equiv v(r, z) e_\theta + q \tag{7.2}$$

and

$$q \equiv u(r, z) e_r + w(r, z) e_z. \tag{7.3}$$

Moreover, equation (2.4b) shows that \mathbf{q} may be found from a stream function $\psi(r, z)$:

$$\mathbf{q} = \mathbf{e}_\theta \times \frac{1}{r} \nabla \psi. \tag{7.4}$$

By use of the polar symmetry of $\mathbf{u}(\cdot)$ and the constitutive assumption (2.6a, b), it follows that the physical components of the extra stress \mathbf{S} are also independent of θ . It is convenient to decompose \mathbf{S} :

$$\mathbf{S} = S \mathbf{e}_\theta \otimes \mathbf{e}_\theta + \mathbf{t} \otimes \mathbf{e}_\theta + \mathbf{e}_\theta \otimes \mathbf{t} + \boldsymbol{\pi}. \tag{7.5}$$

Here, \mathbf{t} denotes a vector in a plane perpendicular to \mathbf{e}_θ , and $\boldsymbol{\pi}$ denotes a symmetric tensor in this plane; the physical components of $\mathbf{t}(t_r, t_z)$ and $\boldsymbol{\pi}(\pi_{rr}, \pi_{rz} = \pi_{zr}, \pi_{zz})$ as well as the scalar S are all independent of θ .

Now, using the identity

$$\operatorname{div}(\mathbf{v} \otimes \mathbf{w}) = (\operatorname{grad} \mathbf{v}) \mathbf{w} + \mathbf{v} \operatorname{div} \mathbf{w}$$

and the notation established in (7.1) gives

$$\operatorname{div} \mathbf{S} = -\frac{1}{r} S \mathbf{e}_r + \left(\nabla \cdot \mathbf{t} + \frac{2}{r} t_r \right) \mathbf{e}_\theta + \operatorname{div} \boldsymbol{\pi}, \tag{7.6}$$

where $\operatorname{div} \boldsymbol{\pi}$ is a vector perpendicular to \mathbf{e}_θ . In a similar manner it is straightforward to show that the acceleration vector $(\operatorname{grad} \mathbf{u}) \mathbf{u}$ may be written as

$$(\operatorname{grad} \mathbf{u}) \mathbf{u} = -\frac{1}{r} v^2 \mathbf{e}_r + \left(\nabla v \cdot \mathbf{q} + \frac{uv}{r} \right) \mathbf{e}_\theta + (\nabla \mathbf{q}) \mathbf{q}. \tag{7.7}$$

Substituting the results of (7.6) and (7.7) into the θ component of the dynamic equation (2.4a) and employing the definition,

$$\Phi \equiv p + \rho g z \quad \text{in } \mathcal{V}_\Omega, \tag{7.8}$$

given earlier we find that

$$-\frac{1}{r} \frac{\partial \Phi}{\partial \theta} + \nabla \cdot \mathbf{t} + \frac{2}{r} t_r = \rho \left(\nabla v \cdot \mathbf{q} + \frac{uv}{r} \right) \quad \text{in } \mathcal{V}_\Omega.$$

Thus, since Φ is to be single-valued in \mathcal{V}_Ω , we see that $\Phi = \Phi(r, z)$, independent of θ , and that the dynamic equation (2.4a) may be replaced by the equivalent set of equations:

$$\begin{aligned} \nabla \cdot \mathbf{t} + \frac{2}{r} t_r &= \rho \left(\nabla v \cdot \mathbf{q} + \frac{uv}{r} \right), \\ -\nabla \Phi - \frac{1}{r} S \mathbf{e}_r + \operatorname{div} \boldsymbol{\pi} &= \rho \left(-\frac{1}{r} v^2 \mathbf{e}_r + (\nabla \mathbf{q}) \mathbf{q} \right) \quad \text{in } \mathcal{V}_\Omega. \end{aligned} \tag{7.9}$$

We take these equations as the fundamental field equations of our problem; \mathbf{t} , S , and $\boldsymbol{\pi}$ are defined in terms of the extra stress \mathbf{S} through (7.5) and \mathbf{q} is related to the stream function ψ through (7.4).

The boundary condition of the present problem are the same as those recorded in (2.4). In terms of the variables introduced above, we may write these in the absence of surface tension as follows:

$$v = \begin{cases} \Omega a & \text{at } r = a, \\ \lambda \Omega b & \text{at } r = b, \end{cases} \quad \psi = \frac{\partial \psi}{\partial r} = 0 \quad \text{at } r = a, b, \quad (7.10a, b, c, d)$$

$$\begin{aligned} \frac{\partial \psi}{\partial r} + h' \frac{\partial \psi}{\partial z} &= t_z - h' t_r = h' [\pi_{zz} - \pi_{rr}] + [1 - (h')^2] \pi_{rz} & (7.10e, f, g, h) \\ &= p_a - \Phi + \pi_{zz} - h' \pi_{rz} + \rho g h = 0 \quad \text{at } z = h, \end{aligned}$$

$$\frac{\partial \psi}{\partial r} = t_z = \pi_{zr} = 0 \quad \text{at } z = -\infty, \quad (7.10i)$$

and

$$\int_a^b r h dr = 0. \quad (7.10j)$$

Finally, we note that the constitutive assumption for the extra stress S from which S , t and π are to be calculated is given by the complete fourth order approximation formula of COLEMAN & NOLL which is recorded in Section 2;

$$S = \sum_{\Gamma=1}^4 S_{\Gamma}, \quad (7.11)$$

where S_{Γ} are defined in terms of the Rivlin-Ericksen tensors A_{Γ} through equations (2.7). For later reference we shall need the recursion formula for the Rivlin-Ericksen tensors for steady motion:

$$\begin{aligned} A_{\Gamma+1} &= (\text{grad } A_{\Gamma}) \mathbf{u} + A_{\Gamma} \text{grad } \mathbf{u} + (A_{\Gamma} \text{grad } \mathbf{u})^T, \quad \Gamma \geq 0 \\ A_0 &= \mathbf{1}. \end{aligned} \quad (7.12)$$

8. First Order Solution

It will turn out, not unexpectedly, that the first order solution for simple fluids is exactly the same as that given earlier in Section 4 for the Newtonian fluid at first order. However, since with the present scheme of analysis the mechanics of developing a solution as well as certain formulae that are derivable at the first order recur at all higher orders, economy is achieved by developing the first order problem in detail.

Using the notation established in Section 4 and recalling that the rest state solution (4.12) also applies for simple fluids, we have again

$$\begin{aligned} h^{[0]} = \mathbf{u}^{[0]} = S^{[0]} &= 0, \\ \Phi^{[0]} &= p_a. \end{aligned} \quad (8.1)$$

According to the general scheme outlined in Section 4, here the first order problem is derived by evaluating the first Ω derivatives of (7.9) and (7.10) at $\Omega = 0$.

Using the zeroth order solution (8.1), we obtain

$$\begin{aligned} \nabla \cdot \mathbf{t}^{(1)} + \frac{2}{r} t_r^{(1)} &= \rho \left(\nabla v \cdot \mathbf{q} + \frac{uv}{r} \right)^{(1)} = 0, \\ -\nabla \Phi^{(1)} - \frac{1}{r} S^{(1)} \mathbf{e}_r + \operatorname{div} \boldsymbol{\pi}^{(1)} &= \rho \left(-\frac{v^2}{r} \mathbf{e}_r + (\nabla \mathbf{q}) \mathbf{q} \right)^{(1)} = 0 \quad \text{in } \mathcal{V}_0, \end{aligned} \tag{8.2a, b}$$

$$v^{(1)} = \begin{cases} a & \text{at } r=a, \\ \lambda b & \text{at } r=b, \end{cases} \quad \psi^{(1)} = \frac{\partial \psi^{(1)}}{\partial r} = 0 \quad \text{at } r=a, b, \tag{8.2c, d, e, f}$$

$$\frac{\partial \psi^{(1)}}{\partial r} = t_z^{(1)} = \pi_{rz}^{(1)} = -\pi_{zz}^{(1)} + \Phi^{(1)} - \rho g h^{[1]} = 0 \quad \text{at } z=0, \tag{8.2g, h, i, j}$$

$$\frac{\partial \psi^{(1)}}{\partial r} = t_z^{(1)} = \pi_{zr}^{(1)} = 0 \quad \text{at } z = -\infty, \tag{8.2k}$$

$$\int_a^b r h^{[1]} dr = 0. \tag{8.2l}$$

In these equations, $\mathbf{t}^{(1)}$, $S^{(1)}$ and $\boldsymbol{\pi}^{(1)}$ are related to the extra stress derivative $S^{(1)}$ through (7.5),

$$S^{(1)} = S^{(1)} \mathbf{e}_\theta \otimes \mathbf{e}_\theta + \mathbf{t}^{(1)} \otimes \mathbf{e}_\theta + \mathbf{e}_\theta \otimes \mathbf{t}^{(1)} + \boldsymbol{\pi}^{(1)}, \tag{8.3}$$

and $S^{(1)}$ is related to the motion through the constitutive assumption (7.11),

$$S^{(1)} = S_1^{(1)} + S_2^{(1)} + S_3^{(1)} + S_4^{(1)}, \tag{8.4}$$

where S_r is defined in (2.7). With the view toward calculating $S^{(1)}$, we first observe from (7.12) and (8.1) that

$$A_{r+1}^{(0)} = 0 \quad (\Gamma \geq 0), \quad A_{r+1}^{(1)} = 0 \quad (\Gamma \geq 1) \tag{8.5a, b}$$

and that

$$A_1^{(1)} = \operatorname{grad} \mathbf{u}^{(1)} + (\operatorname{grad} \mathbf{u}^{(1)})^T. \tag{8.6}$$

These results in combination with (8.4) and (2.7) show that

$$S_2^{(1)} = S_3^{(1)} = S_4^{(1)} = 0$$

and that

$$S^{(1)} = S_1^{(1)} = \mu A_1^{(1)}. \tag{8.7}$$

Now, by use of the notation established in (7.1) it readily follows that since $\mathbf{u}^{(1)} = v^{(1)} \mathbf{e}_\theta + \mathbf{q}^{(1)}$, $\mathbf{q}^{(1)} \equiv u^{(1)} \mathbf{e}_r + w^{(1)} \mathbf{e}_z$, then

$$\operatorname{grad} \mathbf{u}^{(1)} = \mathbf{e}_\theta \otimes \nabla v^{(1)} - \frac{v^{(1)}}{r} \mathbf{e}_r \otimes \mathbf{e}_\theta + \nabla \mathbf{q}^{(1)} + \frac{u^{(1)}}{r} \mathbf{e}_\theta \otimes \mathbf{e}_\theta, \tag{8.8}$$

and with (8.6), (8.7) and (8.3) we find

$$\begin{aligned} S^{(1)} &= \mu \frac{2u^{(1)}}{r}, \quad \mathbf{t}^{(1)} = \mu \left(\nabla v^{(1)} - \frac{v^{(1)}}{r} \mathbf{e}_r \right), \\ \boldsymbol{\pi}^{(1)} &= \mu [\nabla \mathbf{q}^{(1)} + \nabla \mathbf{q}^{(1)T}]. \end{aligned} \tag{8.9a, b, c}$$

In addition, (7.4) yields

$$\mathbf{q}^{(1)} = \mathbf{e}_\theta \times \frac{1}{r} \nabla \psi^{(1)}. \quad (8.10)$$

Returning now with (8.9) to (8.2a), we obtain the field equation for the determination of $v^{(1)}$,

$$\nabla \cdot \nabla v^{(1)} + \frac{1}{r} \frac{\partial v^{(1)}}{\partial r} - \frac{v^{(1)}}{r^2} = 0 \quad \text{in } \mathcal{V}_0; \quad (8.11)$$

the boundary conditions,

$$v^{(1)} = \begin{cases} a & \text{at } r=a \\ \lambda b & \text{at } r=b' \end{cases} \quad t_z^{(1)} = \mu \frac{\partial v^{(1)}}{\partial z} = 0 \quad \text{at } z=0;$$

and the condition that $t_z^{(1)} \rightarrow 0$ as $z \rightarrow -\infty$.

It follows that

$$v^{(1)} = Ar + \frac{B}{r} \quad \text{in } \mathcal{V}_0, \quad (8.12a, b, c)$$

where

$$A = \frac{b^2 \lambda - a^2}{b^2 - a^2}, \quad B = \frac{a^2 b^2 (1 - \lambda)}{b^2 - a^2}.$$

It is clear from the field equation that a solution for $\Phi^{(1)}$ will not exist unless

$$\nabla \cdot \left\{ \mathbf{e}_\theta \times \left(\text{div } \boldsymbol{\pi}^{(1)} - \frac{1}{r} S^{(1)} \mathbf{e}_r \right) \right\} = 0 \quad \text{in } \mathcal{V}_0. \quad (8.13)$$

We now transform (8.13) into a differential equation for the determination of the stream function $\psi^{(1)}$. As a first step toward this end, we observe that with the aid of (7.1a) we may write

$$\nabla \mathbf{q}^{(1)} = \mathbf{e}_r \otimes \nabla u^{(1)} + \mathbf{e}_z \otimes \nabla w^{(1)}. \quad (8.14)$$

Thus, using the notation of (7.1b), we calculate

$$\begin{aligned} \text{div}(\nabla \mathbf{q}^{(1)} + \nabla \mathbf{q}^{(1)T}) &= \mathbf{e}_r \left(\nabla \cdot \nabla u^{(1)} + \frac{1}{r} \frac{\partial u^{(1)}}{\partial r} + \frac{u^{(1)}}{r^2} \right) \\ &\quad + \mathbf{e}_z \left(\nabla \cdot \nabla w^{(1)} + \frac{1}{r} \frac{\partial w^{(1)}}{\partial r} \right). \end{aligned} \quad (8.15)$$

Further, with the aid of (8.9a, c) it follows that

$$\begin{aligned} \text{div } \boldsymbol{\pi}^{(1)} - \frac{1}{r} S^{(1)} \mathbf{e}_r &= \mu \left\{ \mathbf{e}_r \left(\nabla \cdot \nabla u^{(1)} + \frac{1}{r} \frac{\partial u^{(1)}}{\partial r} - \frac{u^{(1)}}{r^2} \right) \right. \\ &\quad \left. + \mathbf{e}_z \left(\nabla \cdot \nabla w^{(1)} + \frac{1}{r} \frac{\partial w^{(1)}}{\partial r} \right) \right\}, \end{aligned} \quad (8.16)$$

and this result in combination with (8.10) and (8.13) after some elementary calculation yields

$$\nabla \cdot \left\{ \mathbf{e}_\theta \times \left(\text{div } \boldsymbol{\pi}^{(1)} - \frac{1}{r} S^{(1)} \mathbf{e}_r \right) \right\} = -\frac{\mu}{r} \mathcal{L}^2 \psi^{(1)} = 0 \quad \text{in } \mathcal{V}_0. \quad (8.17)$$

Here we have made use of the definition given earlier in Section 5 for the operator \mathcal{L} :

$$\mathcal{L}(\cdot) \equiv \left(\nabla \cdot \nabla - \frac{1}{r} \frac{\partial}{\partial r} \right) (\cdot) = \left(\frac{\partial^2}{\partial r^2} + \frac{\partial^2}{\partial z^2} - \frac{1}{r} \frac{\partial}{\partial r} \right) (\cdot). \quad (8.18)$$

The boundary conditions which $\psi^{(1)}$ is subject to are contained in (8.2e, f, g, i, k), and with the aid of (8.9) and (8.10) these reduce to

$$\begin{aligned} \psi^{(1)} = \frac{\partial \psi^{(1)}}{\partial r} = 0 \quad \text{at } r = a, b, \\ \frac{\partial \psi^{(1)}}{\partial r} = \frac{\partial^2 \psi^{(1)}}{\partial r^2} - \frac{\partial^2 \psi^{(1)}}{\partial z^2} = 0 \quad \text{at } z = 0 \quad \text{and } z = -\infty. \end{aligned} \quad (8.19)$$

Thus, the solution of (8.17) and (8.19) for $\psi^{(1)}$ is

$$\psi^{(1)} = 0 \quad \text{in } \mathcal{V}_0, \quad (8.20)$$

and from (8.2b) we see that $\Phi^{(1)}$ is constant:

$$\Phi^{(1)} = C_1 \quad \text{in } \mathcal{V}_0. \quad (8.21)$$

To complete the solution we must determine the constant C_1 and the height correction coefficient $h^{[1]}$. According to (8.2) we may set $\pi_{zz}^{(1)} = 0$ in (8.2j) and find that

$$\rho g h^{[1]} = C_1 \quad \text{at } z = 0.$$

Moreover, application of (8.2l) now shows that

$$h^{[1]} = C_1 = 0. \quad (8.22)$$

9. Second Order Solution: The Free Surface Shape at Lowest Significant Order

Proceeding in a manner established in Chapter I and continued in the preceding section, we may obtain the problem at second order by twice differentiating the general problem (7.9) and (7.10) with respect to Ω (using the substantial derivative on the free surface conditions), and evaluating all resulting equations at $\Omega = 0$. Thus, using the zeroth order solution (8.1), and taking account of the first order solution (8.12), (8.20), (8.21), (8.22), we obtain the following second order problem:

$$\nabla \cdot \mathbf{t}^{(2)} + \frac{2}{r} t_r^{(2)} = \rho \left(\nabla v \cdot \mathbf{q} + \frac{uv}{r} \right)^{(2)} = 0, \quad (9.1 \text{ a, b})$$

$$-\nabla \Phi^{(2)} - \frac{1}{r} S^{(2)} \mathbf{e}_r + \text{div} \pi^{(2)} = \rho \left(-\frac{v^2}{r} \mathbf{e}_r + (\nabla \mathbf{q}) \mathbf{q} \right)^{(2)} = -2\rho \frac{v^{(1)2}}{r} \mathbf{e}_r \quad \text{in } \mathcal{V}_0,$$

$$v^{(2)} = \psi^{(2)} = \frac{\partial \psi^{(2)}}{\partial r} = 0 \quad \text{at } r = a, b, \quad (9.1 \text{ c, d, e})$$

$$\frac{\partial \psi^{(2)}}{\partial r} = t_z^{(2)} = \pi_{rz}^{(2)} = -\pi_{zz}^{(2)} + \Phi^{(2)} - \rho g h^{[2]} = 0 \quad \text{at } z = 0, \quad (9.1 \text{ f, g, h, i})$$

$$\frac{\partial \psi^{(2)}}{\partial r} = t_z^{(2)} = \pi_{zr}^{(2)} = 0 \quad \text{at } z = -\infty, \tag{9.1j}$$

$$\int_a^b r h^{[2]} dr = 0. \tag{9.1k}$$

From (7.11),

$$S^{(2)} = S_1^{(2)} + S_2^{(2)} + S_3^{(2)} + S_4^{(2)}, \tag{9.2}$$

where the derivatives $S_\Gamma^{(2)}$ ($\Gamma = 1, 2, 3, 4$) are to be calculated using (7.12) and the definitions given in (2.7). In addition, the quantities $t^{(2)}$, $S^{(2)}$ and $\pi^{(2)}$ occurring in (9.1) are related to $S^{(2)}$ through (7.5):

$$S^{(2)} = S^{(2)} e_\theta \otimes e_\theta + t^{(2)} \otimes e_\theta + e_\theta \otimes t^{(2)} + \pi^{(2)}. \tag{9.3}$$

We now wish to calculate $S^{(2)}$ and to identify $S^{(2)}$, $t^{(2)}$ and $\pi^{(2)}$. Toward this end, using (7.12), (8.1) and (8.5), we observe that

$$A_{\Gamma+1}^{(2)} = 0 \quad (\Gamma \geq 2) \tag{9.4}$$

and that

$$A_1^{(2)} = \text{grad } u^{(2)} + (\text{grad } u^{(2)})^T \tag{9.5}$$

and

$$A_2^{(2)} = 2 \{ (\text{grad } A_1^{(1)}) u^{(1)} + A_1^{(1)} \text{grad } u^{(1)} + (A_1^{(1)} \text{grad } u^{(1)})^T \}. \tag{9.6}$$

Now, from the first order solution, $u^{(1)} = v^{(1)}(r) e_\theta$, it follows by use of (8.6) and (8.8) that

$$\begin{aligned} \text{grad } u^{(1)} &= \frac{dv^{(1)}}{dr} e_\theta \otimes e_r - \frac{v^{(1)}}{r} e_r \otimes e_\theta, \\ A_1^{(1)} &= \left(\frac{dv^{(1)}}{dr} - \frac{v^{(1)}}{r} \right) (e_r \otimes e_\theta + e_\theta \otimes e_r) = -\frac{2}{r^2} B(e_r \otimes e_\theta + e_\theta \otimes e_r), \end{aligned} \tag{9.7a, b}$$

and these results in combination with (9.6) give

$$A_2^{(2)} = 4 \left(\frac{dv^{(1)}}{dr} - \frac{v^{(1)}}{r} \right)^2 e_r \otimes e_r = \frac{16}{r^4} B^2 e_r \otimes e_r. \tag{9.8}$$

Thus, from (2.7) and (9.4)–(9.8) we see that

$$S_3^{(2)} = S_4^{(2)} = 0$$

and that

$$S^{(2)} = S_1^{(2)} + S_2^{(2)}, \tag{9.9}$$

where

$$S_1^{(2)} = \mu A_1^{(2)},$$

$$S_2^{(2)} = \alpha_1 A_2^{(2)} + 2\alpha_2 A_1^{(1)2} = \frac{8}{r^4} B^2 [(2\alpha_1 + \alpha_2) e_r \otimes e_r + \alpha_2 e_\theta \otimes e_\theta].$$

Following along the path laid out in deriving (8.8), (8.9) and (8.10), we note that since $u^{(2)} = v^{(2)} e_\theta + q^{(2)}$, $q^{(2)} \equiv u^{(2)} e_r + w^{(2)} e_z$ where

$$q^{(2)} = e_\theta \times \frac{1}{r} \nabla \psi^{(2)}, \tag{9.10}$$

then

$$\text{grad } \mathbf{u}^{(2)} = \mathbf{e}_\theta \otimes \nabla v^{(2)} - \frac{v^{(2)}}{r} \mathbf{e}_r \otimes \mathbf{e}_\theta + \nabla \mathbf{q}^{(2)} + \frac{u^{(2)}}{r} \mathbf{e}_\theta \otimes \mathbf{e}_\theta, \tag{9.11}$$

and using (9.3), (9.5) and (9.9), we obtain

$$S^{(2)} = \mu \frac{2u^{(2)}}{r} + \alpha_2 \frac{8}{r^4} B^2, \tag{9.12a, b, c}$$

$$\mathbf{t}^{(2)} = \mu \left(\nabla v^{(2)} - \frac{v^{(2)}}{r} \mathbf{e}_r \right),$$

and

$$\boldsymbol{\pi}^{(2)} = \mu (\nabla \mathbf{q}^{(2)} + \nabla \mathbf{q}^{(2)T}) + (2\alpha_1 + \alpha_2) \frac{8}{r^4} B^2 \mathbf{e}_r \otimes \mathbf{e}_r.$$

The boundary value problem which characterizes $v^{(2)}$ is now readily extracted from (9.12b) and (9.1). We obtain

$$\nabla \cdot \nabla v^{(2)} + \frac{1}{r} \frac{\partial v^{(2)}}{\partial r} - \frac{v^{(2)}}{r^2} = 0 \quad \text{in } \mathcal{V}_0, \tag{9.13}$$

$$v^{(2)} = 0 \quad \text{at } r = a, b, \quad t_z^{(2)} = \mu \frac{\partial v^{(2)}}{\partial z} = 0 \quad \text{at } z = 0, -\infty,$$

and therefore conclude that

$$v^{(2)} = 0 \quad \text{in } \mathcal{V}_0. \tag{9.14}$$

The problem that ultimately characterizes $\Phi^{(2)}$ and $\mathbf{q}^{(2)}$ is initiated with the observation from (9.1b) that $\Phi^{(2)}$ will not exist unless

$$\nabla \cdot \left\{ \mathbf{e}_\theta \times \left(\text{div } \boldsymbol{\pi}^{(2)} - \frac{1}{r} S^{(2)} \mathbf{e}_r + 2\rho \frac{v^{(1)2}}{r} \mathbf{e}_r \right) \right\} = 0 \quad \text{in } \mathcal{V}_0. \tag{9.15}$$

Since $v^{(1)}$ depends only on r , it easily follows from (9.12a, c) and in a manner equivalent to (8.14)–(8.17) that (9.15) reduces to

$$\frac{\mu}{r} \mathcal{L}^2 \psi^{(2)} = 0 \quad \text{in } \mathcal{V}_0, \tag{9.16}$$

where the operator \mathcal{L} is defined in (8.18). The boundary conditions for the function $\psi^{(2)}$ are contained in (9.1d, e, f, h, j) and with the aid of (9.10) and (9.12) they become

$$\psi^{(2)} = \frac{\partial \psi^{(2)}}{\partial r} = 0 \quad \text{at } r = a, b,$$

$$\frac{\partial \psi^{(2)}}{\partial r} = \frac{\partial^2 \psi^{(2)}}{\partial r^2} - \frac{\partial^2 \psi^{(2)}}{\partial z^2} = 0 \quad \text{at } z = 0, -\infty. \tag{9.17}$$

Thus, we find that $\psi^{(2)}$ must identically vanish,

$$\psi^{(2)} = 0 \quad \text{in } \mathcal{V}_0, \tag{9.18}$$

and this along with (9.1 b), (9.10) and (9.12) shows that $\Phi^{(2)}$ must satisfy

$$\nabla\Phi^{(2)} + 16B^2(3\alpha_1 + 2\alpha_2)\frac{1}{r^3}e_r = 2\rho\frac{v^{(1)2}}{r}e_r \quad \text{in } \mathcal{V}_0,$$

where $v^{(1)}$ is given by (8.12). Thus,

$$\Phi^{(2)} = \rho \left(A^2 r^2 + 4AB \log r - \frac{1}{r^2} B^2 \right) + 4B^2(3\alpha_1 + 2\alpha_2)\frac{1}{r^4} + C_2 \quad (9.19)$$

in \mathcal{V}_0 , and the constant C_2 is fixed by the condition

$$\int_a^b r\Phi^{(2)} dr = 0, \quad (9.20)$$

which arises from (9.1 i, k).

It is now possible to give a formula for the second order surface height coefficient;

$$\begin{aligned} h^{[2]} = \frac{1}{\rho g} \Phi^{(2)} = \frac{1}{g} \left\{ A^2 \left[r^2 - \frac{a^2 + b^2}{2} \right] \right. \\ \left. + 4AB \left[\log r + \frac{1}{2} - \frac{b^2 \log b - a^2 \log a}{b^2 - a^2} \right] - B^2 \left[\frac{1}{r^2} - \frac{2 \log b/a}{b^2 - a^2} \right] \right\} \\ + \frac{4}{\rho g} B^2(3\alpha_1 + 2\alpha_2) \left[\frac{1}{r^4} - \frac{1}{a^2 b^2} \right]. \end{aligned} \quad (9.21)$$

Collecting all the results achieved so far, we have

$$\begin{aligned} \mathbf{u} &= \Omega v^{[1]} \mathbf{e} + O(\Omega^3), \\ \Phi &= p_a + \frac{1}{2}\Omega^2 \Phi^{[2]} + O(\Omega^4), \end{aligned} \quad (9.22a, b, c)$$

and

$$h = \frac{1}{2}\Omega^2 h^{[2]} + O(\Omega^4).$$

Here, in the order terms, we have used the symmetry properties which are implied by sign reversal of Ω . In Section 8 we showed that $v^{[1]} = v^{(1)}$, and a short calculation starting from (4.4) shows that $\Phi^{[2]} = \Phi^{(2)}$.

We have shown that the shape of the free surface at lowest significant order depends on the material only through the viscometric constants α_1 and α_2 which are characteristic of the normal stress viscometric functions σ_1 and σ_2 of (2.11). Since these constants can be obtained from viscometric experiments, it follows that the "climbing effect" may be predicted quantitatively when Ω is small and α_1 and α_2 are given by viscometry.

Definite conclusions can be drawn at second order with respect to climbing of simple fluids. In stating these conclusions we shall compare Newtonian fluids, for which $\alpha_1 = \alpha_2 = 0$, to simple fluids with fading memory. Let

$$\delta h \equiv h_N - h_S \quad (9.23)$$

be the discrepancy in the height of the free surface on a Newtonian liquid (h_N) and a simple fluid (h_S). From (9.21) and (9.22c) we see that the height discrepancy

is given by

$$\delta h = -\frac{2\Omega^2}{\rho g} B^2 (3\alpha_1 + 2\alpha_2) \left[\frac{1}{r^4} - \frac{1}{a^2 b^2} \right] + O(\Omega^4) \quad (9.24)$$

and thus changes sign once as r varies from a to b . If $3\alpha_1 + 2\alpha_2 > 0$, the height discrepancy is negative at the inner cylinder and positive at the outer cylinder. Thus, the tendency for a simple fluid to climb the inner cylinder is established when $3\alpha_1 + 2\alpha_2 > 0$.*

Some of the conclusions which one can draw from (9.21)** are more conveniently obtained from the slope formula***

$$\frac{dh}{dr} = \frac{B^2 \Omega^2}{\rho g r^5} \left\{ \rho r^2 \left(1 + \frac{A}{B} r^2 \right)^2 - 8(3\alpha_1 + 2\alpha_2) \right\}, \quad (9.25)$$

where

$$\frac{A}{B} = \frac{b^2 \lambda - a^2}{b^2 a^2 (1 - \lambda)}, \quad B = \frac{a^2 b^2 (1 - \lambda)}{b^2 - a^2}.$$

This remarkable formula has a most interesting consequence when the inner cylinder radius a is small. In the limit as $a \rightarrow 0$, the slope of the free surface has a singularity at the inner radius; in fact, (9.25) has the representation

$$\left. \frac{dh}{dr} \right|_{r=a} = -\frac{8\Omega^2 (1 - \lambda)^2}{\rho g a} (3\alpha_1 + 2\alpha_2) \quad \text{at } a \rightarrow 0. \quad (9.26)$$

Thus, for sufficiently small a , and for $3\alpha_1 + 2\alpha_2 > 0$, the fluid surface will slope sharply up the inner cylinder. The height to which the fluid will rise at $r = a$ in the limit as $a \rightarrow 0$ can be computed with the aid of (9.21). We obtain

$$\lim_{a \rightarrow 0} h(a; \Omega) = -\frac{\lambda^2 b^2 \Omega^2}{4g} + \frac{2\Omega^2 (1 - \lambda)^2}{\rho g} (3\alpha_1 + 2\alpha_2). \quad (9.27)$$

The first term represents the standard paraboloidal depression at the center of the fluid surface due to rigid body rotation of the fluid domain $r \leq b$ of angular velocity $\lambda\Omega$. The second term is purely a non-Newtonian effect, and with $3\alpha_1 + 2\alpha_2 > 0$ it represents a rise or climb of the free surface at the small inner cylinder. If the outer cylinder is held fixed, then $\lambda = 0$ and (9.27) is totally of a non-Newtonian origin. It would be of interest to observe the climbing phenomenon for various cylinders of small radii in a large stationary vat of non-Newtonian fluid.

* This inequality is in good accord with the experiments of MARKOVITZ & BROWN (1963) on polyisobutylene-cetane solutions. This inequality is also substantiated by the experiments of TANNER [16] for polyisobutylene-cetane and polyethylene-oxide-water solutions. Several other experimental investigations by various authors are summarized in Table I of TANNER's paper. These results are also in agreement with this inequality.

** See our *Note Added in Proof* at the end, page 380.

*** SERRIN [13], in a paper which appears to have been largely overlooked in the literature, calculates the slope formula for a Reiner-Rivlin fluid by a procedure which relies on several approximations (*cf.* Section 1 of this paper) which, in retrospect, now appear valid. His slope formula is the same as our (9.25) if we set $\alpha_1 = 0$, as would be required for a Reiner-Rivlin fluid. There are two criteria which may be used to discuss the tendency to climb. The first criterion is associated with the sign of the height discrepancy, as in (9.24). A second criterion, used by SERRIN, is to interpret a negative slope at $r = a$ as a tendency to climb and a negative slope at $r = b > a$ as a tendency to fall. These two criteria need not be the same.

10. Third Order Solution

At third order there is a correction of the azimuthal component of velocity without further alteration of the free surface. The correction in the azimuthal component of velocity depends exclusively on the constants $\mu, 3\alpha_1 + 2\alpha_2, \beta_2 + \beta_3$ which are properties of the three viscometric functions given in (2.11). The results just summarized are derived below.

Differentiating the general problem (7.9) and (7.10) three times with respect to Ω and evaluating all resulting equations at $\Omega=0$ (using the substantial derivative on the free surface), we obtain the following problem at third order:

$$\begin{aligned} \nabla \cdot \mathbf{t}^{(3)} + \frac{2}{r} t_r^{(3)} &= \rho \left(\nabla v \cdot \mathbf{q} + \frac{uv}{r} \right)^{(3)} = 0, \\ -\nabla \Phi^{(3)} - \frac{1}{r} S^{(3)} \mathbf{e}_r + \operatorname{div} \boldsymbol{\pi}^{(3)} &= \rho \left(-\frac{v^2}{r} \mathbf{e}_r + (\nabla \mathbf{q}) \mathbf{q} \right)^{(3)} = 0 \quad \text{in } \mathcal{V}_0, \end{aligned} \tag{10.1 a, b}$$

$$v^{(3)} = \psi^{(3)} = \frac{\partial \psi^{(3)}}{\partial r} = 0 \quad \text{at } r = a, b, \tag{10.1 c, d, e}$$

$$\frac{\partial \psi^{(3)}}{\partial r} = t_z^{(3)} - 3h^{[2]} t_r^{(1)} = \pi_{rz}^{(3)} = -\pi_{zz}^{(3)} + \Phi^{(3)} - \rho g h^{[3]} = 0 \quad \text{at } z = 0, \tag{10.1 f, g, h, i}$$

$$\frac{\partial \psi^{(3)}}{\partial r} = t_z^{(3)} = \pi_{zr}^{(3)} = 0 \quad \text{at } z = -\infty, \tag{10.1 j}$$

$$\int_a^b r h^{[3]} dr = 0. \tag{10.1 k}$$

From (7.11) we have

$$\mathbf{S}^{(3)} = \mathbf{S}_1^{(3)} + \mathbf{S}_2^{(3)} + \mathbf{S}_3^{(3)} + \mathbf{S}_4^{(3)}, \tag{10.2}$$

where the derivatives $\mathbf{S}_\Gamma^{(3)}$ ($\Gamma = 1, 2, 3, 4$) are obtained from (7.12) and the definitions (2.7). Also, the quantities $\mathbf{t}^{(3)}, S^{(3)}$ and $\boldsymbol{\pi}^{(3)}$ in (10.1) are related to $\mathbf{S}^{(3)}$ through (7.5) according to

$$\mathbf{S}^{(3)} = S^{(3)} \mathbf{e}_\theta \otimes \mathbf{e}_\theta + \mathbf{t}^{(3)} \otimes \mathbf{e}_\theta + \mathbf{e}_\theta \otimes \mathbf{t}^{(3)} + \boldsymbol{\pi}^{(3)}. \tag{10.3}$$

It is now necessary to relate the above three quantities to the fluid motion, and we do so by calculating $\mathbf{S}^{(3)}$ and identifying the members of the decomposition (10.3). First, it follows from (7.12), (8.1), (8.5) and (9.4) that

$$A_{\Gamma+1}^{(3)} = 0 \quad (\Gamma \geq 3), \tag{10.4}$$

and that

$$A_1^{(3)} = \operatorname{grad} \mathbf{u}^{(3)} + (\operatorname{grad} \mathbf{u}^{(3)})^T, \tag{10.5}$$

and using, in addition, the result $\mathbf{u}^{(2)} = 0$ and (9.5), (9.7 a) and (9.8), we also obtain

$$A_2^{(3)} = A_3^{(3)} = 0. \tag{10.6 a, b}$$

Now, from (2.7) and the previously observed zero tensors in (8.5), (9.4) and (10.4), we see that

$$S_4^{(3)} = 0$$

and conclude, using $\mathbf{u}^{(2)}=0$, (10.6), $\mathbf{S}_2^{(3)}=0$, (9.7b) and (9.8), that

$$\mathbf{S}^{(3)} = \mathbf{S}_1^{(3)} + \mathbf{S}_3^{(3)},$$

where

$$\begin{aligned} \mathbf{S}_1^{(3)} &= \mu \mathbf{A}_1^{(3)}, \\ \mathbf{S}_3^{(3)} &= 3[\beta_2(\mathbf{A}_2^{(2)} \mathbf{A}_1^{(1)} + \mathbf{A}_1^{(1)} \mathbf{A}_2^{(2)}) + \beta_3(\text{tr } \mathbf{A}_2^{(2)}) \mathbf{A}_1^{(1)}] \\ &= -\frac{96}{r^6} B^3 (\beta_2 + \beta_3) (\mathbf{e}_r \otimes \mathbf{e}_\theta + \mathbf{e}_\theta \otimes \mathbf{e}_r). \end{aligned} \tag{10.7}$$

Finally, since $\mathbf{u}^{(3)} = v^{(3)} \mathbf{e}_\theta + \mathbf{q}^{(3)}$, $\mathbf{q}^{(3)} \equiv u^{(3)} \mathbf{e}_r + w^{(3)} \mathbf{e}_z$, we may write, analogous to (9.10) and (9.11),

$$\begin{aligned} \mathbf{q}^{(3)} &= \mathbf{e}_\theta \times \frac{1}{r} \nabla \psi^{(3)}, \\ \text{grad } \mathbf{u}^{(3)} &= \mathbf{e}_\theta \otimes \nabla v^{(3)} - \frac{v^{(3)}}{r} \mathbf{e}_r \otimes \mathbf{e}_\theta + \nabla \mathbf{q}^{(3)} + \frac{u^{(3)}}{r} \mathbf{e}_\theta \otimes \mathbf{e}_\theta, \end{aligned} \tag{10.8a, b}$$

and with (10.3), (10.5) and (10.7) conclude that

$$\begin{aligned} \mathbf{S}^{(3)} &= \mu \frac{2\mathbf{u}^{(3)}}{r}, \quad \mathbf{t}^{(3)} = \mu \left(\nabla v^{(3)} - \frac{v^{(3)}}{r} \mathbf{e}_r \right) - \frac{96}{r^6} B^3 (\beta_2 + \beta_3) \mathbf{e}_r, \\ \boldsymbol{\pi}^{(3)} &= \mu (\nabla \mathbf{q}^{(3)} + \nabla \mathbf{q}^{(3)T}). \end{aligned} \tag{10.9a, b, c}$$

The boundary value problem which characterizes $v^{(3)}$ is now easily extracted from (10.9b), (10.1a, c, g, j) and (9.22c), (9.23) and (8.9b), (8.12a). We obtain

$$\begin{aligned} \nabla \cdot \nabla v^{(3)} + \frac{1}{r} \frac{\partial v^{(3)}}{\partial r} - \frac{v^{(3)}}{r^2} &= -\frac{384}{r^7} B^3 \frac{(\beta_2 + \beta_3)}{\mu} \quad \text{in } \mathcal{V}_0, \\ v^{(3)} &= 0 \quad \text{at } r = a, b, \end{aligned} \tag{10.10a, b, c, d}$$

$$\begin{aligned} t_z^{(3)} - 3h^{[2]Y} t_r^{(1)} &= \mu \left\{ \frac{\partial v^{(3)}}{\partial z} + \frac{12B^3}{gr^7} \left[\left(1 + \frac{A}{B} r^2 \right)^2 r^2 - \frac{8(3\alpha_1 + 2\alpha_2)}{\rho} \right] \right\} = 0 \\ &\text{at } z = 0, \end{aligned}$$

$$t_z^{(3)} = \mu \frac{\partial v^{(3)}}{\partial z} = 0 \quad \text{at } z = -\infty.$$

The solution to problem (10.10) may be written as

$$v^{(3)} = v_p^{(3)} + v_H^{(3)} \quad \text{in } \mathcal{V}_0. \tag{10.11a}$$

Here

$$v_p^{(3)} = -\frac{16B^3(\beta_2 + \beta_3)}{\mu} \left[\frac{1}{r^5} + \frac{b^2 + a^2}{a^4 b^4} r - \frac{a^4 + b^4 + a^2 b^2}{a^4 b^4 r} \right], \tag{10.11b}$$

and $v_H^{(3)}$ satisfies the homogeneous field equation (10.10a) and the boundary conditions (10.10b, c, d). We find that

$$v_H^{(3)} = \sum_{n=1}^{\infty} B_n e^{\lambda_n z} \mathcal{C}(\lambda_n r), \tag{10.11c}$$

where $\mathcal{C}(\lambda_n r)$ are the cylinder functions defined in (5.3b), λ_n are the positive roots of (5.3c), and B_n are Fourier-Bessel coefficients chosen so that (10.11) will satisfy (10.10c). We note, using (4.4), that $v^{[3]} = v^{(3)}$ in \mathcal{V}_0 .

The boundary value problem that characterizes $\Phi^{(3)}$ and $q^{(3)}$ is observed from (10.9a, c) and (10.1) to be exactly the same as that problem encountered in Section 8 for $\Phi^{(1)}$ and $q^{(1)}$. Moreover, the final problem of calculating $h^{[3]}$ is also precisely the same as that treated in Section 8 for $h^{[1]}$. Thus, by analogy the results (8.20), (8.21) and (8.22) yield

$$\psi^{(3)} = \Phi^{(3)} = h^{[3]} = 0. \tag{10.12}$$

We close this section with an examination of the differences between the third order solution for Newtonian fluids given in Section 5 and the results just obtained. The non-Newtonian effects enter the third order solution at two points. The constant $3\alpha_1 + 2\alpha_2$ appears in the solution through the Fourier-Bessel coefficients B_n which are chosen so that (10.11) will satisfy (10.10c). When $3\alpha_1 + 2\alpha_2 = 0$, the function $v_H^{(3)}$ is exactly the third order correction of the azimuthal velocity component of a Newtonian fluid which was given in Section 5.

The constant $\beta_2 + \beta_3$ enters the solution at third order through $v_P^{(3)}(r)$. This function depends on r alone and does not arise as an effect of the free surface. Indeed, this same correction $v_P^{(3)}$ would appear as a third order correction in a power series solution of the problem of Couette flow of a simple fluid filling the whole annular space ($-\infty < z < \infty$) between rotating cylinders.

We have found that the material constants μ , $3\alpha_1 + 2\alpha_2$, and $\beta_2 + \beta_3$ enter the solution at third order; these constants belong to the set of constants (2.11) which characterize the three fundamental viscometric functions.

11. The Problem at Fourth Order

At fourth order the fluid motion departs from that of Couette type and, in addition to circulating around the axis of rotation, begins to move in the axial and radial directions as well. Thus, a cross flow in the planes $\theta = \text{constant}$ will be discernible. Moreover, the free surface profile will again be altered. The new circulation and consequent correction of the height of the free surfaces depends exclusively on characterizing constants of the viscometric functions; in addition to the viscometric constants μ , α_1 , α_2 , and $\beta_2 + \beta_3$ already present in the first, second and third order solutions, we now also find dependence on the two additional viscometric constants γ_6 and $\gamma_3 + \gamma_4 + \gamma_5 + \frac{1}{2}\gamma_6$ (cf. (2.11)). The results just summarized are derived below.

In order to obtain the problem at fourth order, we differentiate the general problem (7.9), (7.10) four times with respect to Ω (using the substantial derivative on the free surface) and evaluate all resulting equations at $\Omega = 0$. By use of the results at previous orders, this procedure yields

$$\begin{aligned} \nabla \cdot \mathbf{t}^{(4)} + \frac{2}{r} \mathbf{t}_r^{(4)} &= \rho \left(\nabla v \cdot \mathbf{q} + \frac{uv}{r} \right)^{(4)} = 0, \\ -\nabla \Phi^{(4)} - \frac{1}{r} S^{(4)} \mathbf{e}_r + \text{div } \boldsymbol{\pi}^{(4)} &= \rho \left(-\frac{v^2}{r} \mathbf{e}_r + (\nabla \mathbf{q}) \mathbf{q} \right)^{(4)} = -8\rho \frac{v^{(1)} v^{(3)}}{r} \mathbf{e}_r \quad \text{in } \mathcal{V}_0, \end{aligned} \tag{11.1 a, b}$$

$$v^{(4)} = \psi^{(4)} = \frac{\partial \psi^{(4)}}{\partial r} = 0 \quad \text{at } r = a, b, \tag{11.1c, d, e}$$

$$\frac{\partial \psi^{(4)}}{\partial r} = t_z^{(4)} = \pi_{rz}^{(4)} + 6h^{[2]} (\pi_{zz}^{(2)} - \pi_{rr}^{(2)}) = -\pi_{zz}^{(4)} + \Phi^{(4)} - \rho g h^{[4]} = 0 \tag{11.1f, g, h, i}$$

at $z = 0,$

$$\frac{\partial \psi^{(4)}}{\partial r} = t_z^{(4)} = \pi_{zr}^{(4)} = 0 \quad \text{at } z = -\infty, \tag{11.1j}$$

$$\int_a^b r h^{[4]} dr = 0. \tag{11.1k}$$

As in the earlier order problems, we have from (7.11) that

$$S^{(4)} = S_1^{(4)} + S_2^{(4)} + S_3^{(4)} + S_4^{(4)}, \tag{11.2}$$

where the derivatives $S_\Gamma^{(4)}$ ($\Gamma = 1, 2, 3, 4$) are obtained from (7.12) and (2.7), and we utilize the decomposition (7.5) to reach

$$S^{(4)} = S^{(4)} e_\theta \otimes e_\theta + t^{(4)} \otimes e_\theta + e_\theta \otimes t^{(4)} + \pi^{(4)}. \tag{11.3}$$

In order to obtain formulae for $S^{(4)}$, $t^{(4)}$ and $\pi^{(4)}$ in terms of the motion, we need to calculate various Rivlin-Ericksen tensor derivatives $A_\Gamma^{(4)}$, use (2.7) to calculate $S^{(4)}$, and identify the terms occurring in (11.3). Following this procedure, we observe directly from (7.12) that

$$A_1^{(4)} = \text{grad } \mathbf{u}^{(4)} + (\text{grad } \mathbf{u}^{(4)})^T, \tag{11.4}$$

and by a lengthy but straightforward calculation based upon (7.12) and the results at lower order, we find

$$A_2^{(4)} = -16 \frac{B}{r^2} \left(e_r \otimes \nabla v^{(3)} + \nabla v^{(3)} \otimes e_r - 2 \frac{v^{(3)}}{r} e_r \otimes e_r \right). \tag{11.5}$$

Further use of (7.12) together with the results (8.1), (8.5), $\mathbf{u}^{(2)} = 0$, and (10.6a) readily shows that

$$A_3^{(4)} = 0, \tag{11.6}$$

while (7.12) with the results (8.1), (8.5b), (9.4) and (10.6b) yields

$$A_4^{(4)} = 0. \tag{11.7}$$

Now, using (2.7) and the previously established results of (8.5), $\mathbf{u}^{(2)} = 0$, (10.6a) and (11.6), we find that

$$S_3^{(4)} = 0,$$

and with the additional aid of (9.4), (10.6b) and (11.7), we find

$$S^{(4)} = S_1^{(4)} + S_2^{(4)} + S_4^{(4)}, \tag{11.8a}$$

where

$$S_1^{(4)} = \mu A_1^{(4)}, \tag{11.8b}$$

$$S_2^{(4)} = \alpha_1 A_2^{(4)} + 4\alpha_2 (A_1^{(1)} A_1^{(3)} + A_1^{(3)} A_1^{(1)}), \quad (11.8c)$$

$$S_4^{(4)} = 6\gamma_3 A_2^{(2)2} + 12\gamma_4 (A_2^{(2)} A_1^{(1)2} + A_1^{(1)2} A_2^{(2)}) \\ + 6\gamma_5 (\text{tr } A_2^{(2)}) A_2^{(2)} + 12\gamma_6 (\text{tr } A_2^{(2)}) A_1^{(1)2} \\ + 12\gamma_8 (\text{tr } A_2^{(2)} A_1^{(1)}) A_1^{(1)}. \quad (11.8d)$$

With the aid of (9.7b), (10.5), (10.8b) and (11.5) we reduce the right-hand side of (11.8c) and obtain

$$S_2^{(4)} = -\frac{8}{r^2} B(2\alpha_1 + \alpha_2) \left(e_r \otimes \nabla v^{(3)} + \nabla v^{(3)} \otimes e_r - 2 \frac{v^{(3)}}{r} e_r \otimes e_r \right) \\ - \frac{16}{r^2} B\alpha_2 \left(\frac{\partial v^{(3)}}{\partial r} - \frac{v^{(3)}}{r} \right) e_\theta \otimes e_\theta. \quad (11.9)$$

Also, using (9.7b) and (9.8), we reduce $S_4^{(4)}$ in (11.8d) to

$$S_4^{(4)} = \frac{1536}{r^8} B^4 (\gamma_3 + \gamma_4 + \gamma_5 + \frac{1}{2} \gamma_6) e_r \otimes e_r + \frac{768}{r^8} B^4 \gamma_6 e_\theta \otimes e_\theta. \quad (11.10)$$

Finally, since $u^{(4)} = v^{(4)} e_\theta + q^{(4)}$, $q^{(4)} \equiv u^{(4)} e_r + w^{(4)} e_z$, we may write, analogous to (10.8), that

$$q^{(4)} = e_\theta \times \frac{1}{r} \nabla \psi^{(4)}, \\ \text{grad } u^{(4)} = e_\theta \otimes \nabla v^{(4)} - \frac{v^{(4)}}{r} e_r \otimes e_\theta + \nabla q^{(4)} + \frac{u^{(4)}}{r} e_\theta \otimes e_\theta \quad (11.11)$$

and thus conclude by reference to (11.3), (11.4), (11.8)–(11.11) that

$$S^{(4)} = \mu \frac{2u^{(4)}}{r} - \frac{16}{r^2} B\alpha_2 \left(\frac{\partial v^{(3)}}{\partial r} - \frac{v^{(3)}}{r} \right) + \frac{768}{r^8} B^4 \gamma_6, \\ t^{(4)} = \mu \left(\nabla v^{(4)} - \frac{v^{(4)}}{r} e_r \right), \quad (11.12a, b, c)$$

$$\pi^{(4)} = \mu (\nabla q^{(4)} + \nabla q^{(4)T}) - \frac{8}{r^2} B(2\alpha_1 + \alpha_2) \left(e_r \otimes \nabla v^{(3)} + \nabla v^{(3)} \otimes e_r - \frac{2v^{(3)}}{r} e_r \otimes e_r \right) \\ + \frac{1536}{r^8} B^4 (\gamma_3 + \gamma_4 + \gamma_5 + \frac{1}{2} \gamma_6) e_r \otimes e_r.$$

The boundary value problem which determines $v^{(4)}$ is readily seen from (11.12b) and (11.1a, c, g, j) to be exactly the same as that given in (9.13) for the determination of $v^{(2)}$. Thus,

$$v^{(4)} = 0 \quad \text{in } \mathcal{V}_0. \quad (11.13)$$

As in all earlier cases, to obtain the problem which characterizes $\Phi^{(4)}$ and $q^{(4)}$, we observe from (11.1b) that in order for $\Phi^{(4)}$ to exist, the following integrability condition must be satisfied:

$$\nabla \cdot \left\{ e_\theta \times \left(\text{div } \pi^{(4)} - \frac{1}{r} S^{(4)} e_r + 8\rho \frac{v^{(1)} v^{(3)}}{r} e_r \right) \right\} = 0 \quad \text{in } \mathcal{V}_0. \quad (11.14)$$

The terms involving $q^{(4)}$ in this equation lead to the operator \mathcal{L}^2 just as in the calculation leading to (8.17). Thus, using (11.12a, c), we simplify (11.14) to the following equivalent form:

$$\mu \mathcal{L}^2 \psi^{(4)} = -8 \frac{\partial}{\partial z} \left\{ \frac{4}{r^2} B(\alpha_1 + \alpha_2) \left(\frac{\partial v^{(3)}}{\partial r} - \frac{v^{(3)}}{r} \right) + \rho v^{(1)} v^{(3)} \right\} \quad \text{in } \mathcal{V}_0, \quad (11.15)$$

where $v^{(1)}$ is given in (8.12) and $v^{(3)}$ is given in (10.11). The boundary conditions which restrict $\psi^{(4)}$ are contained in (11.1d, e, f, h, j). Using (10.10c) and (9.12c) with $u^{(2)}=0$, we may considerably simplify these boundary conditions so that with (11.12c) we obtain

$$\psi^{(4)} = \frac{\partial \psi^{(4)}}{\partial r} = 0 \quad \text{at } r = a, b, \quad (11.16a, b, c, d)$$

$$\frac{\partial \psi^{(4)}}{\partial r} = \frac{\partial^2 \psi^{(4)}}{\partial r^2} - \frac{\partial^2 \psi^{(4)}}{\partial z^2} = 0 \quad \text{at } z = 0, -\infty.$$

Aside from the presence of the first term on the right-hand side of (11.15), the above boundary value problem for $\psi^{(4)}$ is the same as that encountered at fourth order for the Newtonian fluid (see (5.8)). All of the work of Section 6 directed toward the solution for a "narrow" gap also applies to the present situation; we need only take for the function γ appearing in Section 6 the form

$$\gamma = -8 \left\{ \frac{4}{r^2} B(\alpha_1 + \alpha_2) \left(\frac{\partial v^{(3)}}{\partial r} - \frac{v^{(3)}}{r} \right) + \rho v^{(1)} v^{(3)} \right\} \quad (11.17)$$

rather than that given earlier in (5.7). An explicit solution of the narrow gap approximation to the fourth order problem can now be set down merely by changing the definition of appropriate constants. It is easy to establish, as remarked at the end of Section 5, that in \mathcal{V}_0

$$q^{[4]} = q^{(4)} \quad \text{and} \quad \Phi^{[4]} = \Phi^{(4)}.$$

It remains for us to verify our claim that the solution at fourth order depends solely on characterizing constants of the three viscometric functions. To see this, note that the solution $\psi^{(4)}$ of (11.15), (11.16) depends on the material through constants already appearing in $v^{(3)}$ and in addition upon $\alpha_1 + \alpha_2$. Since $\psi^{(4)}$ is the stream function for the circulatory motion $q^{(4)}$, the whole motion at fourth order thus depends only on characteristic viscometric constants.

To show that $h^{[4]}$ also depends solely on constants which are related to the three viscometric functions, we observe from (11.1i), (11.12c) and (11.11) that $h^{[4]}$ is determined from

$$\frac{2\mu}{r} \frac{\partial^2 \psi^{(4)}}{\partial r \partial z} + \Phi^{(4)} - \rho g h^{[4]} = 0 \quad \text{at } z = 0 \quad (11.18)$$

once $\psi^{(4)}$ is known and $\Phi^{(4)}$ is obtained from integration of (11.1b). The arbitrary additive constant in $\Phi^{(4)}$ is fixed by (11.1k). Upon integrating (11.18), using (11.16a), we find

$$\int_a^b r \Phi^{(4)} \Big|_{z=0} dr = 0. \quad (11.19)$$

It is clear from (11.18) that $h^{[4]}$ depends only on those material constants that are present in $\psi^{(4)}$ and $\Phi^{(4)}$, the former of which has already been discussed. With regard to $\Phi^{(4)}$, it follows from (11.1 b) and the structure of $S^{(4)}$ and $\pi^{(4)}$ in (11.12) that the dependent material constants in addition to those on which $\psi^{(4)}$ depends are α_2 , γ_6 , and $\gamma_3 + \gamma_4 + \gamma_5 + \frac{1}{2}\gamma_6$. That these constants are preproperties only of the viscometric functions can be seen by reference to the formulae (2.11).

We close our analysis of Chapter II with a summary of the perturbation series through order four. We have found that

$$\begin{aligned} v(r, z; \Omega) &= \mathbf{u} \cdot \mathbf{e}_\theta = \Omega v^{(1)} + \frac{1}{6} \Omega^3 v^{(3)} + O(\Omega^5), \\ \mathbf{q}(r, z; \Omega) &= \mathbf{u} - \mathbf{e}_\theta v = \frac{1}{24} \Omega^4 \mathbf{q}^{(4)} + O(\Omega^6), \\ \Phi(r, z; \Omega) &= p_a + \frac{1}{2} \Omega^2 \Phi^{(2)} + \frac{1}{24} \Omega^4 \Phi^{(4)} + O(\Omega^6), \end{aligned} \quad (11.20)$$

and

$$h(r; \Omega) = \frac{1}{2} \Omega^2 h^{[2]} + \frac{1}{24} \Omega^4 h^{[4]} + O(\Omega^6),$$

where the fields $v^{(1)}(r_0)$, $v^{(3)}(r_0, z_0)$, $\Phi^{(2)}(r_0)$ and $h^{[2]}(r_0)$ are known exactly and explicitly. The fields $\mathbf{q}^{(4)}(r_0, z_0)$ and $\Phi^{(4)}(r_0, z_0)$ are known explicitly and approximately when the gap between the cylinders $(1 - a/b)$ is sufficiently small. We note that the left side of (11.20) is defined in \mathcal{V}_Ω and the right in \mathcal{V}_0 . To evaluate the right side of (11.20), we must invert the transformation $\mathcal{V}_\Omega \rightarrow \mathcal{V}_0$ (cf. the discussion following (4.4)).

Chapter III. Surface Tension

12. The Effects of Surface Tension on the Free Surface

In the remainder of this paper we shall extend our work to include a variety of effects due to surface tension. The present section is mainly devoted to the special case of "neutral wetting", and the effect of including surface tension in the previous perturbation analysis of the free surface profile. The governing equation which is used to determine the shape of the free surface was derived in (2.2) by balancing the normal component of the jump in stress across the free surface with the surface tension T in the surface film. For the present purposes it is most convenient to work with this fundamental balance law in the form (2.4h);

$$\frac{T}{r} (r h' / \sqrt{1 + h'^2})' - \rho g h - p_a + \Phi - S_{zz} + h' S_{rz} = 0 \quad \text{at } z = h. \quad (12.1)$$

In this second order differential equation the quantities Φ , S_{zz} and S_{rz} are supposed to be determined as part of the solution to the complete boundary value problem (2.4) for either a Newtonian fluid (2.5) or for some other simple fluid within the framework of (2.6).

Given the fields S_{zz} , S_{rz} and Φ and provided that suitable boundary conditions for h are prescribed, equation (12.1) determines the shape of the free surface.*

* The solution of (12.1) is clearly coupled to the fluid motion; the fields S and Φ cannot, in general, be given separately, and (12.1) and the fluid motion problem must be solved simultaneously.

Boundary conditions are usually prescribed in the form of contact angles (these are called wetting angles) at the junctions of the free surface and the container walls.* For the present case of rotational symmetry, in order to define the wetting angle ϕ at a point of contact between the fluid surface film and the wall, consider a tangent vector and a normal vector to the surface profile at the point of contact; the tangent vector is directed outward with respect to the adjacent wall and the normal vector is directed outward with respect to the fluid. The angle ϕ is the angle between this tangent vector and the wall and is measured in the direction of the normal, $0 \leq \phi \leq \pi$. With the above definition, we may regard the conditions

$$h'(a; \Omega) = \cot \phi_a, \quad h'(b; \Omega) = -\cot \phi_b \quad (12.2)$$

as prescribed, where ϕ_a and ϕ_b are the wetting angles at the inner and outer cylinder walls, respectively. When the wetting angle ϕ is in the interval $\left(\frac{\pi}{2}, \pi\right]$ the fluid is said to wet the wall, and when it is in the interval $\left[0, \frac{\pi}{2}\right)$ the fluid does not wet the wall. The situation $\phi = \frac{\pi}{2}$ is defined as neutral wetting.

When the fluid is in the rest state ($\Omega = 0$), then, as mentioned in Section 2, the extra stress S vanishes, and from (2.4a) we see that Φ is constant. The particular constant can be determined in terms of the boundary conditions (12.2) by multiplying (12.1) by r , integrating the result, and applying the condition of constant volume (2.1e). Thus, the boundary value problem for the free surface profile in the rest state is rendered explicit. If we multiply rh into the appropriate form of (12.1) for the rest state and integrate, we find with the aid of (2.1e) that

$$\rho g \int_a^b r h^2 dr + T \int_a^b \frac{r h'^2 dr}{\sqrt{1+h'^2}} - T \left[\frac{r h h'}{\sqrt{1+h'^2}} \right]_a^b = 0. \quad (12.3)$$

Thus we conclude that *the rest state has $h(r; 0) \equiv 0$ in $a \leq r \leq b$ when either (a) $T = 0$ or (b) $h'(a; 0) = h'(b; 0) = 0$.*

In both the rest state and, in fact, when $\Omega \neq 0$, one physical effect of the surface tension is to diminish the mean square deflection of the free surface from its average value by an amount equal to the value of the second integral in (12.3). The coefficient of surface tension also enters into the boundary term in (12.3), but the physics of the situation at the boundary is as much associated with the property of adhesion and its relation to the appropriate wetting angles as it is of surface tension

It is natural to expect that the adhesion conditions at the boundary are of minor importance in the general problem (2.4) when the shape of the free surface is influenced by strong forces associated with the interior fluid motion. In such circumstances surface tension still can be important and, in fact, even crucial. One striking example of such a case is exhibited in Figure 1.3 of the monograph of COLEMAN, MARKOVITZ & NOLL [1]. This figure, demonstrating the climbing effect

* The contact angles which actually develop in a given physical situation appear to depend on the history of the wetting [7]. These angles should be regarded as "prescribed", *a posteriori*, from experiment.

of non-Newtonian fluids between a rotating inner and fixed outer cylinder, shows a balloon or "hub" of fluid which surrounds the inner rotating cylinder and gradually merges through a necked down annular column with the main body of liquid below. The fluid balloon, being sheared at its free surface only by the frictional air drag, is probably in a nearly rigid body rotation. The whole configuration appears to be supported by normal stresses operating at the bottom of the necked down column, and, in fact, would come apart because of the action of the centrifugal forces if it were not contained by the action of tensile forces in the surface film.

The perturbation analysis which we constructed earlier is not convenient when surface tension is acting *and* the wetting angles at the cylinder walls are left arbitrary. Moreover, even if it were possible to carry out that analysis, we could not expect it to apply to phenomena like the one just described which is very far removed from the state of rest.

A main simplifying feature of the earlier perturbation work was that $h^{[0]} = h^{[1]} \equiv 0$. While the first condition implied that all subsequent perturbation problems at higher order were set in a domain with a flat top, $-\infty < z \leq h^{[0]} \equiv 0$, an important consequence of $h^{[1]} \equiv 0$ resulted from the formula (4.16). These simplifications were exploited in our analysis with $T=0$, and they also hold for neutral wetting films, to which we now turn.

The boundary conditions for neutral wetting,

$$h'(a; \Omega) = h'(b; \Omega) = 0 \quad \left(\phi_a = \phi_b = \frac{\pi}{2} \right), \quad (12.4)$$

are representative on the allowed range ($0 \leq \phi \leq \pi$). They are also mathematically convenient because they lead us to the results

$$h^{[0]} = h^{[1]} \equiv 0; \quad (12.5a, b)$$

(12.5a) is implied by (12.4) and property (b) of the remark following (12.3), and (12.5b) can be derived by developing the first order problem, either as in Section 4 or as in Section 8. The development leads to exactly the same equations as given previously except now we must satisfy also the surface tension equation and the related boundary conditions. To find the first order perturbation, we apply the substantial derivative to (12.1) and (12.4) and evaluate the result at $\Omega=0$; whence

$$\begin{aligned} \frac{T}{r} \{r h^{[1]'}\}' - \rho g h^{[1]} + \Phi^{(1)} - S_{zz}^{(1)} &= 0 \quad \text{at } z=0, \\ h^{[1]'} &= 0 \quad \text{at } r=a, b. \end{aligned} \quad (12.6a, b)$$

As previously demonstrated, it again follows here that $S_{zz}^{(1)}=0$, and $\Phi^{(1)}=C_1$ (constant). Using (8.2*l*), we have $C_1=0$, and (12.6a, b) then implies that $h^{[1]}=0$.

The effect of the boundary conditions for neutral wetting makes itself felt in the boundary conditions for the higher order problems. However, it can be shown that this effect appears in the boundary conditions for the determination of $u^{(l)}$ and $\Phi^{(l)}$ at order l only through quantities which are known from the solutions of the lower order problems, and thus $u^{(l)}$ and $\Phi^{(l)}$ can be obtained (up to an additive

constant in $\Phi^{(l)}$ without knowing $h^{[l]}$. The additive constant in $\Phi^{(l)}$ is determined by application of the constant volume condition (2.1e) in combination with the surface tension equation (12.1) and the boundary conditions (12.4), all derived at order l . This resulting set of equations has the following structure:

$$\begin{aligned} \frac{T}{r} \{r h^{[l]'}\}' - \rho g h^{[l]} + \Phi^{(l)} - S_{zz}^{(l)} \\ + \{\text{known function of } r \text{ from lower order solutions}\} = 0 \quad \text{at } z=0, \\ h^{[l]'} = 0 \quad \text{at } r=a, b, \quad \int_a^b r h^{[l]} dr = 0. \end{aligned} \quad (12.7a, b, c)$$

Because $h=0$ in $a \leq r \leq b$ is the only solution of the problem

$$(r h')' - \frac{\rho g}{T} r h = 0, \quad h' = 0 \quad \text{at } r=a, b, \quad (12.8)$$

it follows that the problem (12.7) is uniquely invertible.

The first and possibly most interesting non-trivial effect of the surface tension in the case of neutral wetting arises at second order ($l=2$). Here the problem, which determines the correction coefficient $h^{[2]}$ for the profile of the free surface of a simple fluid, is

$$\begin{aligned} \frac{T}{r} \{r h^{[2]'}\}' - \rho g h^{[2]} + \Phi^{(2)} = 0 \quad \text{in } a < r < b, \\ h^{[2]'} = 0 \quad \text{at } r=a, b, \quad \int_a^b r h^{[2]} dr = 0, \end{aligned} \quad (12.9a, b, c)$$

where from (9.19) $\Phi^{(2)}$ is given by

$$\Phi^{(2)} = \rho \left(A^2 r^2 + 4AB \log r - \frac{B^2}{r^2} \right) + \frac{4B^2}{r^4} (3\alpha_1 + 2\alpha_2) + C_2 \quad (12.9d)$$

and C_2 is a constant. Application of (2.9c) gives the same value of the constant C_2 as was obtained in the case of zero surface tension in Section 9. Thus, the second of equations (9.21) represents the correct function $\Phi^{(2)}$ which should be substituted into the differential equation (12.9a).

We write the solution of (12.9) in the form

$$h^{[2]} = \frac{1}{\rho g} \Phi^{(2)} + H, \quad (12.10)$$

where the first term on the right-hand side represents the free surface profile as calculated in (9.21) when surface tension effects are neglected, and where $H(r)$ denotes the alteration of the free surface profile due to the action of surface tension. It follows from (12.9) that $H(r)$ must satisfy the following boundary value problem:

$$\frac{T}{r} \{r H'\}' - \rho g H + \frac{T}{\rho g} \left\{ \frac{4\rho}{r^2} \left(A^2 r^2 - \frac{B^2}{r^2} \right) + \frac{64B^2}{r^6} (3\alpha_1 + 2\alpha_2) \right\} = 0 \quad (12.11a)$$

in $a < r < b$, with

$$H' + \frac{2}{gr} \left(Ar + \frac{B}{r} \right)^2 - \frac{16B^2}{\rho g r^5} (3\alpha_1 + 2\alpha_2) = 0 \quad \text{at } r = a, b. \quad (12.11 b)$$

The unique solution of (12.11) has the form

$$H = \alpha I_0 \left(\sqrt{\frac{\rho g}{T}} r \right) + \beta K_0 \left(\sqrt{\frac{\rho g}{T}} r \right) + H_p, \quad (12.12)$$

where H_p is a particular solution of (12.11 a) and may be represented in terms of modified Struve functions, where $I_0(\cdot)$ and $K_0(\cdot)$ denote modified Bessel functions and where the constants α and β must be chosen to satisfy (12.11 b). It would now be possible to determine the magnitude of H at the inner and outer cylinder walls and to assess the importance of surface tension and the assumptions of neutral wetting with respect to the climbing phenomenon of non-Newtonian fluids; we shall not consider this question further here, however.*

Each higher order perturbation also generates a problem of the form (12.9); at order l the problem is the same, except $\Phi^{(l)}$ is a different known function of r . Thus, it follows that the correction coefficient $h^{[l]}$ can be also written in the form given in (12.10) and (12.12).

An extension of the foregoing analysis to problems which do not satisfy the boundary conditions of neutral wetting can be achieved by a perturbation method. This would require replacing the single power series solution in Ω by a three parameter power series in Ω , $\phi_a - \pi/2$ and $\phi_b - \pi/2$. The calculation of the various corrections due to the deviation of the wetting angles from neutral is straightforward and will not be given here.*

We shall complete our discussion of the effects of surface tension with considerations which arise in the limit when T is considered small. These considerations are easily exposed but have more generality when the basic fluid motion is nearly a state of rigid rotation. Thus, in the following section we outline a perturbation analysis which is valid near the state of rigid rotation. In Section 14 we shall return to the surface tension problem for the limiting case $T \rightarrow 0$ and obtain boundary layer results based on a singular perturbation argument.

13. Perturbation from the State of Rigid Axial Rotation

We now consider the free surface problem as a perturbation problem from the base state of rigid body axial rotation. In the earlier perturbation analysis from the state of rest we found the following: at the zeroth order, a hydrostatic pressure and a flat surface (for either $T=0$ or for neutral wetting); at first order, a purely circumferential velocity field without change of pressure; at second order, a pressure change and free surface deflection without change of velocity; at third order, a z dependent correction of the circumferential velocity to balance the unequilibrated shear stress on the deflected free surface as well as to account for the non-Newtonian fluid behavior, without change of pressure; and, at fourth order, a general overturning of the fluid induced by a non-conservative central force associated with the third order correction. At the fourth order, an additional correction to the pressure and the free surface profile was predicted though not derived in detail.

* See Part II.

For the perturbation from the state of rigid axial rotation, we shall show now that all the effects which were just mentioned pile up at first order.

Mathematically, the general problem is again governed by the system (2.1), (2.2), except that here we consider Ω as arbitrary but fixed and λ as a parameter that is supposed to be close to the value 1; when $\lambda=1$, the fluid body is in the state of rigid axial rotation and it occupies the domain \mathcal{V}_0 which is contained between the two cylinders and is below the non-flat free surface. When $\lambda \neq 1$, then the two boundary cylinders rotate at different angular speeds and the fluid domain \mathcal{V}_0 takes on a new form $\mathcal{V}_{\lambda-1}$ ($\mathcal{V}_{\lambda-1}$ is equivalent to the domain \mathcal{V}_Ω which was introduced in earlier sections of this paper). In the present section we give a brief account of the associated domain perturbation problem. To do this, we introduce a domain mapping $\mathcal{V}_0 \rightarrow \mathcal{V}_{\lambda-1}$ just as in (4.1), (4.2) and (4.3), and define a substantial derivative operator $\frac{d(\cdot)}{d\lambda}$ such that on the free surface

$$\frac{d(\cdot)}{d\lambda} = \frac{\partial(\cdot)}{\partial\lambda} + \frac{dh}{d\lambda} \frac{\partial(\cdot)}{\partial z}. \tag{13.1}$$

Here, $h=h(r; \lambda-1)$ denotes the height of the free surface and is analogous to $h(r; \Omega)$ of the previous sections. This differential operator is crucial to the perturbation analysis since we seek a solution of (2.1) for a simple fluid in the form

$$\begin{Bmatrix} \mathbf{u} \\ \Phi \\ h \end{Bmatrix} = \sum_0^\infty \frac{1}{n!} \begin{Bmatrix} \mathbf{u}^{[n]} \\ \Phi^{[n]} \\ h^{[n]} \end{Bmatrix} (\lambda-1)^n, \tag{13.2}$$

where, for example,

$$\mathbf{u}^{[n]} = \left. \frac{d^n \mathbf{u}}{d\lambda^n} \right|_{\lambda=1},$$

the evaluation at $\lambda=1$ implying that the resulting independent variables are those of the reference domain \mathcal{V}_0 (*i.e.*, the state of rigid axial rotation).

For a simple fluid (2.6), the characterization of the problem given in Section 7 is equally valid here; we need to solve the field equations (7.9) in $\mathcal{V}_{\lambda-1}$ subject to the conditions (7.10). The only change is that here we shall consider the effects of surface tension, so that in place of (7.10h) we have to satisfy

$$p_a - \Phi + \pi_{zz} - h' \pi_{rz} + \rho g h = \frac{T}{r} \left(\frac{r h'}{\sqrt{1+h'^2}} \right)' \quad \text{at } z=h, \tag{13.3a}$$

subject to the wetting conditions (analogous to (12.2))

$$h'(a; \lambda-1) = \cot \phi_a, \quad h'(b; \lambda-1) = -\cot \phi_b. \tag{13.3b}$$

For λ close to 1 it is appropriate to apply the approximate constitutive equation (7.11) of COLEMAN & NOLL. As was remarked in Section 2 this formula requires that the fluid be of the fading memory type and, in addition, that the motion be slow in the sense of retardation. Here we may interpret $(\lambda-1)$ as the retardation

parameter, since when $\lambda=1$ there is no internal relative fluid motion, and in that case the extra stress S vanishes.*

We turn now to the problem at the zeroth order ($\lambda=1$), when the fluid body is rotating rigidly about the common axis of the two cylindrical containers. Here, as noted in Section 2, we have, in the notation of (13.2), $S^{[0]}=0$, so that from (7.5)

$$S^{[0]}=t^{[0]}=\pi^{[0]}=0 \quad \text{in } \mathcal{V}_0; \quad (13.4a, b, c)$$

since the motion is rigid, we have

$$\psi^{[0]}=0, \quad v^{[0]}=r\Omega \quad \text{in } \mathcal{V}_0. \quad (13.4d, e)$$

Now, all relevant conditions of (7.9) and (7.10) are satisfied except for the second of (7.9), which becomes

$$\nabla\Phi^{[0]}=\rho r\Omega^2 e_r \quad \text{in } \mathcal{V}_0,$$

and the condition of constant volume (7.10j). Thus, we have

$$\Phi^{[0]}=\frac{\rho\Omega^2}{2}r^2+c_0, \quad (13.5a)$$

where the constant c_0 is determined by application of (7.10j) to (13.3) after being reduced by (13.4); we obtain

$$c_0=p_a-\frac{\rho\Omega^2}{4}(b^2+a^2)+\frac{2T}{b^2-a^2}(b\cos\phi_b+a\cos\phi_a). \quad (13.5b)$$

Finally at zeroth order, the residual problem that governs the free surface profile in the state of rigid axial rotation is given by the non-linear second order differential equation

$$\begin{aligned} &\frac{\rho\Omega^2}{4}(b^2+a^2)-\frac{2T}{b^2-a^2}(b\cos\phi_b+a\cos\phi_a) \\ &-\frac{\rho\Omega^2}{2}r^2+\rho gh^{[0]}=\frac{T}{r}\left\{\frac{r h^{[0]'}}{\sqrt{1+h^{[0]'}{}^2}}\right\}' \quad (a < r < b), \end{aligned} \quad (13.6a)$$

subject to the boundary conditions

$$h^{[0]'}=\begin{cases} \cot\phi_a & \text{at } r=a, \\ -\cot\phi_b & \text{at } r=b. \end{cases} \quad (13.6b, c)$$

The solution to this problem fixes the domain \mathcal{V}_0 in which all subsequent perturbation problems are solved. It turns out that the general structure of these subsequent problems is already revealed at the first order to which we now turn.

At first order the relevant problem is obtained by differentiating the general problem (7.9), (7.10), (13.3) with respect to λ and evaluating all resulting equations at $\lambda=1$. In general the substantial derivative $\frac{d(\cdot)}{d\lambda}$ must be employed for both the

* The qualifying remarks made in Section 2 regarding the retarded motion associated with the parameter Ω can also be carried over here without modification for the parameter $\lambda-1$.

field equations and the boundary conditions since the domain $\mathcal{V}_{\lambda-1}$ is dependent on λ . However, since the field equations interior to $\mathcal{V}_{\lambda-1}$ are identities in their spatial dependence, partial differentiation of these with respect to λ will suffice.* Using the zeroth order solution (13.4), we derive the following first order problem from (7.9), (7.10) and (13.3):

$$\begin{aligned} \nabla \cdot \mathbf{t}^{(1)} + \frac{2}{r} t_r^{(1)} &= \rho \left(\nabla v \cdot \mathbf{q} + \frac{uv}{r} \right)^{(1)} = 2\rho \Omega u^{(1)}, \\ -\nabla \Phi^{(1)} - \frac{1}{r} S^{(1)} \mathbf{e}_r + \operatorname{div} \boldsymbol{\pi}^{(1)} &= \rho \left(-\frac{v^2}{r} \mathbf{e}_r + (\nabla \mathbf{q}) \mathbf{q} \right)^{(1)} \quad (13.7 \text{ a, b}) \\ &= -2\rho \Omega v^{(1)} \mathbf{e}_r \quad \text{in } \mathcal{V}_0, \end{aligned}$$

$$v^{(1)} = \begin{cases} 0 & \text{at } r=a, \\ \Omega b & \text{at } r=b, \end{cases} \quad \psi^{(1)} = \frac{\partial \psi^{(1)}}{\partial r} = 0 \quad \text{at } r=a, b, \quad (13.7 \text{ c, d, e, f})$$

$$\frac{\partial \psi^{(1)}}{\partial r} + h^{[0]'} \frac{\partial \psi^{(1)}}{\partial z} = t_z^{(1)} - h^{[0]'} t_r^{(1)} \quad (13.7 \text{ g, h, i})^{**}$$

$$= h^{[0]'} (\pi_{zz}^{(1)} - \pi_{rr}^{(1)}) + (1 - h^{[0]'/2}) \pi_{rz}^{(1)} = 0 \quad \text{at } z=h^{[0]},$$

$$\frac{\partial \psi^{(1)}}{\partial r} = t_z^{(1)} = \pi_{zz}^{(1)} = 0 \quad \text{at } z=-\infty, \quad (13.7 \text{ j})$$

$$-\Phi^{(1)} + \pi_{zz}^{(1)} - h^{[0]'} \pi_{rz}^{(1)} + \rho g h^{[1]} = \frac{T}{r} \left\{ \frac{r h^{[1]'}}{(1 + h^{[0]'/2})^{3/2}} \right\}' \quad \text{at } z=h^{[0]}, \quad (13.7 \text{ k})$$

$$h^{[1]'} = 0 \quad \text{at } r=a, b, \quad (13.7 \text{ l})$$

$$\int_a^b r h^{[1]} dr = 0. \quad (13.7 \text{ m})$$

In these equations $\mathbf{t}^{(1)}$, $S^{(1)}$, and $\boldsymbol{\pi}^{(1)}$ are related to the extra stress derivative $S^{(1)}$ through an expression equivalent to (8.3), and just as in Section 8, we also have here

$$S^{(1)} = S_1^{(1)} = \mu A_1^{(1)}, \quad (13.8)$$

where $A_1^{(1)}$ is given analogous to (8.6). Thus $\mathbf{t}^{(1)}$, $S^{(1)}$, $\boldsymbol{\pi}^{(1)}$, and $\mathbf{q}^{(1)}$ have the structure of (8.9 a, b, c) and (8.10).

Now, from (13.7a, b) it follows as in Section 8 that the two (mixed) field equations that govern the functions $v^{(1)}$ and $\psi^{(1)}$ are

$$\mu \left(\nabla \cdot \nabla v^{(1)} + \frac{1}{r} \frac{\partial v^{(1)}}{\partial r} - \frac{v^{(1)}}{r^2} \right) = 2\rho \Omega \frac{1}{r} \frac{\partial \psi^{(1)}}{\partial z} \quad \text{in } \mathcal{V}_0, \quad (13.9 \text{ a})$$

* In the spirit of the notation established in (13.2), we shall also use $(\cdot)^{(n)}$ to denote $\left. \frac{\partial^n (\cdot)}{\partial \lambda^n} \right|_{\lambda=1}$.

** These three boundary conditions are equivalent to $\frac{\partial \psi^{(1)}}{\partial \mathbf{t}} = t_n^{(1)} = \pi_{nt}^{(1)} = 0$ at $z=h^{[0]}$, where \mathbf{n} and \mathbf{t} denote the unit normal and tangent vectors to the free surface of \mathcal{V}_0 .

and

$$\frac{\mu}{r} \mathcal{L}^2 \psi^{(1)} = -2\rho\Omega \frac{\partial v^{(1)}}{\partial z} \quad \text{in } \mathcal{V}_0, \quad (13.9b)$$

where the operator \mathcal{L} is defined in (8.18). The boundary conditions for these equations are contained in (13.7c–j) and can easily be cast solely in terms of $v^{(1)}$ and $\psi^{(1)}$ by use of (8.9), though we shall not do so here. The solution for $v^{(1)}$ and $\psi^{(1)}$ guarantees the existence of $\Phi^{(1)}$ from (13.7b) up to an additive constant which is fixed by the requirement (13.7m). Finally, to complete the solution at first order, the inhomogeneous linear system (13.7k, 1) must be solved, where the inhomogeneities are known from previous calculations; this solution provides the first correction to the free surface profile.

If there is to be a general circulation present at first order, then $\psi^{(1)}=0$ in \mathcal{V}_0 cannot be a solution of the problem. To see this, observe from (13.9b) that if $\psi^{(1)} \equiv 0$, then $v^{(1)}$ would be independent of z in \mathcal{V}_0 , and (13.9a) has the general solution $v^{(1)} = \alpha r + \beta/r$ where α and β are constants. In this case (13.7c, d) shows that $\beta \neq 0$, and (13.7h) becomes $\beta h^{(0)'} = 0$ at $z = h^{(0)}$. This contradicts the requirements of (13.6) for the free surface profile at zeroth order.

An explicit general solution to the problem at first order seems beyond hope, but it may, in fact, prove tractable to boundary layer analysis in the limit $\Omega \rightarrow \infty$ (*i.e.*, large Ekman number). Eventually deep in the interior we would expect the solution to tend to the potential flow $\psi^{(1)}=0$, $\mathbf{u}^{(1)} = v^{(1)} \mathbf{e}_\theta$ with $v^{(1)} = 1/r$. This assumption of potential flow could not satisfy the free surface conditions, and a region of transition would be expected. In any region of gentle variation, large values of Ω will imply a very weak z -dependence for $\psi^{(1)}$ and the additional terms which make $v^{(1)}$ exact; also, a very weak z -dependence is not compatible with the conditions at the free surface. Hence, a boundary layer of the Ekman type would be natural to expect at the free surface.

Another type of boundary layer which is of interest in the free surface problem can be defined in the limit of small surface film tension $T \rightarrow 0$. This, of course, is a most important limit since nearly all of the work in the field of fluid *dynamics* with free surfaces sets $T=0$ from the outset. In the next section we shall briefly consider a singular perturbation analysis associated with this limit.

14. Surface Tension Boundary Layers

Situations in which the surface tension coefficient T is small are pervasive; even fluids which have a large surface tension coefficient in their pure state can have a drastically reduced value for T when contaminated with small amounts of soap or other wetting agents.

The mathematical problem associated with the limit as $T \rightarrow 0$ involves a singular perturbation, and it is natural to expect that $T=0$ approximates the situation in which T is small. The road to a regular perturbation analysis for small T is blocked by the fact that when $T=0$, it is not possible to satisfy the boundary conditions of prescribed wetting angle. Therefore, when T is small, the actual solution should be close to the one appropriate for $T=0$ except in narrow regions where the fluid surface is adjacent to its container; it is here that the wetting conditions will force rapid variations in the free surface height h .

The singular nature of the limit $T \rightarrow 0$ appears at each order in the perturbation series (13.2) but is most conveniently discussed at the zeroth order. At zeroth order an explicit formal boundary layer solution can be found. The analysis shows that the corner region in which surface tension is important is roughly the thickness of the capillary radius $\sqrt{T/\rho g}$, and thus this constant serves as a convenient scaling parameter.

The problem at zeroth order is stated in (13.6), and we shall be interested here in its solution for small T . Since we expect that the solution of (13.6) for $T=0$ is a valid approximation to the exact solution everywhere except near the cylinder walls $r=a$ and $r=b$, it will be convenient to introduce the difference between the exact solution and the solution for $T=0$ which is given by

$$h_0^{[0]} \equiv \frac{\Omega^2}{2g} \left(r^2 - \frac{a^2 + b^2}{2} \right). \quad (14.1)$$

In fact, since our interest is concerned with a boundary layer analysis near either $r=a$ or $r=b$, we shall henceforth choose the point $r=b$, to be specific, and work with the discrepancy function $H(r)$ defined according to

$$H(r) \equiv h^{[0]}(r) - h_0^{[0]}(b) = h^{[0]}(r) - \frac{\Omega^2}{4g} (b^2 - a^2). \quad (14.2)$$

This defines the actual free surface height as compared to the height that would be found at the wall $r=b$ in the absence of surface tension. Defining the non-negative constant ε through

$$\varepsilon \equiv \frac{T}{\rho g}, \quad (14.3)$$

it follows from (13.6) and (14.2) that H is governed by the problem

$$H + \frac{\Omega^2}{2g} (b^2 - r^2) - \frac{2\varepsilon}{b^2 - a^2} (b \cos \phi_b + a \cos \phi_a) - \frac{\varepsilon}{r} \left(\frac{rH'}{\sqrt{1+H'^2}} \right)' = 0 \quad \text{in } a < r < b, \quad (14.4a)$$

$$H' = \begin{cases} \cot \phi_a & \text{at } r=a, \\ -\cot \phi_b & \text{at } r=b. \end{cases} \quad (14.4b, c)$$

To study (14.4) in a neighborhood of $r=b$, we introduce the boundary layer coordinate x through

$$\varepsilon^m x = b - r. \quad (14.5)$$

Here, m is a positive real number that will be chosen so as to retain the (second) order of the boundary layer equation that approximates (14.4a) near $x=0$ for small ε . One overlying requirement of any analysis near $r=b$ (i.e., $x=0$) is that the boundary condition (14.4c) should retain its importance. This requirement motivates the scaling of $H(r)$ to $y(x)$ of the form

$$\varepsilon^m y = H, \quad (14.6)$$

and yields for (14.4c) the condition

$$y' = \cot \phi_b \quad \text{at } x=0. \tag{14.7}$$

With this established, the differential equation (14.4a) may be written as

$$\begin{aligned} \varepsilon^m y + \frac{\Omega^2}{2g} \varepsilon^m x(2b - x\varepsilon^m) - \frac{2\varepsilon}{b^2 - a^2} (b \cos \phi_b + a \cos \phi_a) \\ - \frac{\varepsilon^{1-m} y''}{(1 + y'^2)^{\frac{3}{2}}} + \frac{\varepsilon y'}{(b - x\varepsilon^m)\sqrt{1 + y'^2}} = 0 \quad (0 < x < \varepsilon^{-m}(b - a)). \end{aligned}$$

Thus, with the choice $m = \frac{1}{2}$, the most significant term for this equation at any fixed x and sufficiently small ε produces the following boundary layer equation:

$$y + F_R x - \frac{y''}{(1 + y'^2)^{\frac{3}{2}}} = 0 \quad 0 < x < \infty, \tag{14.8}$$

where we have introduced a Froude number

$$F_R \equiv \frac{\Omega^2 b}{g}. \tag{14.9}$$

We seek a solution of (14.8) and (14.7) which will match the boundary layer to the interior. The interior is defined by the asymptotic limit $\varepsilon \rightarrow 0$, $r \neq b$ fixed. In this limit $h^{(0)}(r) = h_0^{(0)}(r)$, which in combination with (4.1) yields

$$H + \frac{\Omega^2}{2g} (b^2 - r^2) = 0 \quad \text{for } 0 < \varepsilon \ll 1. \tag{14.10}$$

In terms of $y(x)$, this condition has for its most significant contribution in powers of ε the approximation

$$y + F_R x = 0 \quad \text{as } x \rightarrow \infty, \tag{14.11}$$

and this together with (14.7) and (14.8) completes the derivation of the boundary layer problem.

We now obtain two characterizing properties of the solution to the boundary layer problem and describe their physical implications:

- (i) $y(x) \rightarrow -F_R x$ monotonically as $x \rightarrow \infty$,
- (ii) if $\left\{ \begin{array}{l} \cot \phi_b + F_R < 0 \\ \cot \phi_b + F_R = 0 \\ \cot \phi_b + F_R > 0 \end{array} \right\}$, then $\left\{ \begin{array}{l} y(0) > 0 \\ y(0) = 0 \\ y(0) < 0 \end{array} \right\}$. (14.12)

In the absence of surface tension, the slope of the surface $y = -F_R x$ near the wall $x=0$ is determined by the ratio of centrifugal to gravitational forces ($F_R = \Omega^2 b/g$). Physically we regard (14.12) as characterizing the relative rise at the boundary due to prescribing a wetting angle for the film relative to the surface $y = -F_R x$ which is formed near $x=0$ when $T=0$.

The result (i) shows that the magnitude of the discrepancy is largest at the wall and decreases monotonically with distance from the wall. To prove (i), introduce

$$\tilde{y} \equiv y + F_R x \tag{14.13}$$

into (4.7), (4.8) and (4.11); we find that

$$\begin{aligned} \tilde{y} - \frac{\tilde{y}''}{\{1 + (\tilde{y}' - F_R)^2\}^{\frac{3}{2}}} &= 0 \quad (0 < x < \infty), \\ \tilde{y}' &= \cot \phi_b + F_R \quad \text{at } x=0, \\ \tilde{y} &= 0 \quad \text{as } x \rightarrow \infty. \end{aligned} \tag{14.14a, b, c}$$

Thus, \tilde{y}''/\tilde{y} is of positive sign for all x , so that \tilde{y} cannot have a positive maximum or a negative minimum. Three alternatives are now possible: either \tilde{y} has a positive minimum, a negative maximum, or is a monotone function. The first and second of these alternatives is excluded by the fact that in either case, the condition at $x \rightarrow \infty$ in (14.14c) could not be satisfied. The result (i) follows.

To obtain (ii), first suppose that ϕ_b satisfies $\cot \phi_b + F_R < 0$. Then (14.14b) shows that $\tilde{y}'(0) < 0$ and the conclusion $\tilde{y}(0) > 0$ follows from monotonicity and the condition (14.14c) as $x \rightarrow \infty$. Using (14.13), we see that $y(0) > 0$. If $\cot \phi_b = -F_R$, then (14.14b) shows that $\tilde{y}' = 0$ at $x=0$, and again, (i) and (14.14c) shows that $\tilde{y}(x) = 0$ for all x so that with (14.13) we reach $y(0) = 0$. Finally, if $\cot \phi_b > -F_R$, a similar argument shows that $y(0) < 0$. This completes the proof of (ii).

A study of the boundary layer problem in the form (14.14) shows that the explicit solution can be found in the form of elliptic functions. This solution has a simple asymptotic limit which may be obtained directly by linearizing (14.14) for large x . In this way we find that

$$\tilde{y} = k \exp\{-x(1 + F_R^2)^{\frac{3}{2}}\} \quad \text{as } x \rightarrow \infty,$$

where k is a constant. While there is little profit in exhibiting the full solution since its most interesting features are fairly well described in the remarks given above, it is relatively easy to obtain a first integral in the form

$$\frac{1}{2} \tilde{y}^2 - \frac{F_R(\tilde{y}' - F_R) - 1}{\sqrt{1 + (\tilde{y}' - F_R)^2}} = \text{constant} = \sqrt{F_R^2 + 1}, \tag{14.15}$$

where the constant has been evaluated from the conditions $\tilde{y} = \tilde{y}' = 0$ as $x \rightarrow \infty$. Thus, at the wall $x=0$; using (14.2), (14.6), (14.13) and (14.14b), we find that

$$|h^{[0]}(b) - h_0^{[0]}(b)|^2 = 2\varepsilon^2 \left\{ \sqrt{F_R^2 + 1} + \frac{F_R \cot \phi_b - 1}{\sqrt{1 + \cot^2 \phi_b}} \right\} \geq 0, \tag{14.16}$$

which gives the magnitude at $r=b$ of the height discrepancy between the actual height and the height that would exist without surface tension. An entirely analogous analysis of the boundary layer problem at $r=a$ will yield a similar result for the height discrepancy due to wetting at the cylinder wall $r=a$.

This completes the boundary layer analysis of the problem of wetting at the free surface and the adjacent cylinder wall when the fluid rotates as a rigid body and the surface tension T or, more exactly, the capillary radius $\varepsilon = T/\rho g$ is small. We found that the effects of the small surface tension are confined to a narrow layer of size $\varepsilon^{\frac{1}{2}}$ near the cylinder wall, and that this same $\varepsilon^{\frac{1}{2}}$ also scales the height discrepancy.

The interest of one of us (JOSEPH) in nonlinearly viscous fluids stems, in part, from a stimulating lecture of C. TRUESDELL on the meaning of viscometry delivered to meeting of the fluid mechanics division of the American Physical Society in 1971. TRUESDELL's lecture will be published in the 1973 volume of the Annual Reviews of Fluid Mechanics.

Our work was supported in part by U. S. National Science Foundation grants GK-12500 (D. D. J) and GK-25139 (R. L. F). We are indebted to Mr. JUNG YUL YOO for checking the calculation of Section 6 and for his very valuable assistance with the numerical calculations of Part II.

Note Added in Proof. Equation (9.21) has been recently obtained by Dr. ALAN KAYE ("The shape of a liquid surface between rotating concentric cylinders" presented at 6^e Congrès International de Rhéologie, Lyons, Septembre, 1972). KAYE's study of the climbing of second order fluids is carried out only to second order. His theoretical result (our 9.21) is not in agreement with his (or our) experiments because he has neglected surface tension (see Part II).

References

1. COLEMAN, B. D., H. MARKOVITZ, & W. NOLL, *Viscometric Flows of non-Newtonian Fluids*. Springer Tracts in Natural Philosophy. Vol. 5, 1966.
2. COLEMAN, B. D., & W. NOLL, An approximation theorem for functionals with applications in continuum mechanics. *Arch. Rational Mech. Anal.* **6**, 355-370 (1960).
3. ERICKSEN, J. L., Secondary flow phenomena in non-linear fluids. *TAPPI* **42**, 773-775 (1959).
4. GARABEDIAN, P., *Partial Differential Equations*. John Wiley & Sons, Inc. Chap. 15, Section 1, 1964.
5. HADAMARD, J., Mémoire sur le problème d'analyse relatif à l'équilibre des plaques élastiques encastrées. *Mémoires des Savants Etrangers* **33** (1908).
6. HILLMAN, A. P., & H. E. SALZER, Roots of $\sin z = z$. *Phil. Mag.* **39**, 575-577 (1943).
7. HUH, C., & L. SCRIVEN, Hydrodynamic model of steady movement of a solid contact line. *J. Colloid & Interface Science* **24**, 325-351 (1971).
8. JOSEPH, D. D., Parameter and domain dependence of eigenvalues of elliptic partial differential equations. *Arch. Rational Mech. Anal.*, **35**, 169-177 (1967).
9. JOSEPH, D. D., *Global Stability of Fluid Motion*. Springer Tracts in Natural Philosophy. To appear.
10. LICARI, J. P., & W. H. WARNER. Domain dependence of eigenvalues of vibrating plates. *SIAM Journ. Appl. Math.*, to appear (1973).
11. PAYNE, L., Isoperimetric inequalities and their applications. *SIAM Review*, **9**, 453-488 (1967).
12. ROBBINS, C. I., & R. C. T. SMITH, A table of roots of $\sin z = z$. *Phil. Mag.* **34**, 1004-1005 (1943).
13. SERRIN, J., Poiseuille and Couette flow of non-Newtonian fluids. *ZAMM* **39**, 295-299 (1959).
14. SERRIN, J., Stability of viscous fluid motions. *Arch. Rational Mech. Anal.* **3**, 1-13 (1959).
15. SMITH, R. C. T., The bending of a semi-infinite strip. *Australian Journ. Sci. Res.* **5**, 227 (1952).
16. TANNER, R. I., Some methods for estimating the normal stress functions in viscometric flows. *Trans. Soc. Rheology* **14**, 483-507 (1970).
17. TRUESDELL, C., & W. NOLL, *The Non-Linear Field Theories of Mechanics*. FLÜGGE's Handbuch der Physik, III/3. Berlin-Heidelberg-New York: Springer 1965.

Department of Aerospace Engineering
and Mechanics
University of Minnesota

(Received June 28, 1972)