

# Chapter 12

## Performance Improvement of OEM Brake Caliper by Manufacturing with Design Changes



Mauli Mirajkar, Parvathidevi Gurubaran, P. Jeevan Sunny, Armugasunder Konar, and P. K. Ambadekar

### Abbreviations

$W_T$	Weight transfer
$W$	Mass
$H$	Height of center of gravity
$L$	Wheel base
$g$	Acceleration due to gravity
$\mu$	Coefficient of friction b/w surface and tyre
$W_{FD}$	Front dynamic load
$W_{RD}$	Rear dynamic load
$B_{FF}$	Braking force front
$B_{TF}$	Braking torque front
$B_{FR}$	Braking force rear
$B_{TR}$	Braking torque rear
$F_{mc}$	Force on master cylinder
$A_{mc}$	Area of piston master cylinder

---

M. Mirajkar · P. Gurubaran (✉) · P. Jeevan Sunny · A. Konar · P. K. Ambadekar  
Department of Mechanical Engineering, SIES Graduate School of Technology, Navi Mumbai,  
India

e-mail: [parvathidevi.guru@gmail.com](mailto:parvathidevi.guru@gmail.com)

M. Mirajkar

e-mail: [mauli.mirajkar16@siesgst.ac.in](mailto:mauli.mirajkar16@siesgst.ac.in)

P. Jeevan Sunny

e-mail: [jeevansunny@yahoo.co.in](mailto:jeevansunny@yahoo.co.in)

A. Konar

e-mail: [skonar121306@gmail.com](mailto:skonar121306@gmail.com)

P. K. Ambadekar

e-mail: [pkaspa2018@gmail.com](mailto:pkaspa2018@gmail.com)

$P_{Mc}$	Pressure on master cylinder
$F_{p1}$	Pedal force
$F_{caliper}$	Force on caliper
$F_{disc}$	Force on disc

## Introduction

The foremost function of a braking system is to slow down a vehicle by conversion of its kinetic energy into heat through friction. In a hydraulic braking system, brake fluid generally containing ethylene glycol is used to transmit the pressure from the actuating mechanism to the braking mechanism. When the brake pedal in a hydraulic system is pressed the pushrod connected to it exerts force on the pistons inside the master cylinder (Fig. 12.1). This causes the fluid inside the reservoir to flow into the pressure chamber, resulting in an escalation in pressure of the entire hydraulic system. This forces the fluid to flow through the hydraulic lines or brake hose toward the caliper, thereby displacing the pistons of the caliper. The pistons of the caliper then apply force on the brake pads, pushing them against the rotating disc. The friction generated between the pads and the disc produces a braking torque which slows down the vehicle. Heat generated due to friction is either dissipated through vents and channels in the discs via convection or is conducted through the pads. When the brake pedal is released the springs in the master cylinder assembly return the piston back into its position. This action relieves the hydraulic pressure on the caliper and produces suction to the caliper piston causing it to move back into its casing and allowing the brake pads to release the disc. Brake caliper are of two types, namely floating and fixed. In a floating caliper (Fig. 12.2) the piston is on the inboard side of the caliper and the caliper is mounted on a guiding pin acting as a cylindrical

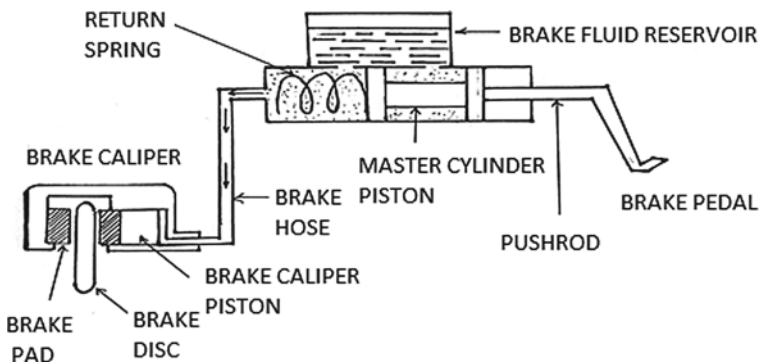
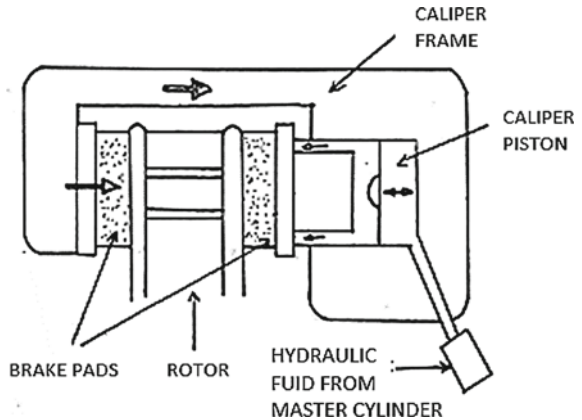

Fig. 12.1 Working of hydraulic disc braking system

**Fig. 12.2** Floating caliper



support. In a fixed caliper (Fig. 12.3) pistons are present on both sides of the disc and can be directly fixed to the mountings on the uprights.

The different components of a floating caliper are shown in Fig. 12.4 in order to explain the modifications in the design explicitly. The primary component of a caliper is the frame of the brake caliper which provides the function of casing all the components of caliper, viz., the piston, seals, brake pads, and bleeding screw in their position and enabling relative motion between them for effective working of the braking system. The banjo bolt is a hollow perforated bolt which transfers the brake fluid from the brake hose into the brake caliper. The caliper piston seal performs the dual function of sealing the piston bore and retracting the caliper piston after brakes are applied. The dust boot prevents the entry of any dust or foreign substance inside the caliper. The design of the seal groove assembly of a brake caliper highly influences the braking performance of the caliper. A bleed screw is a component

**Fig. 12.3** Fixed caliper

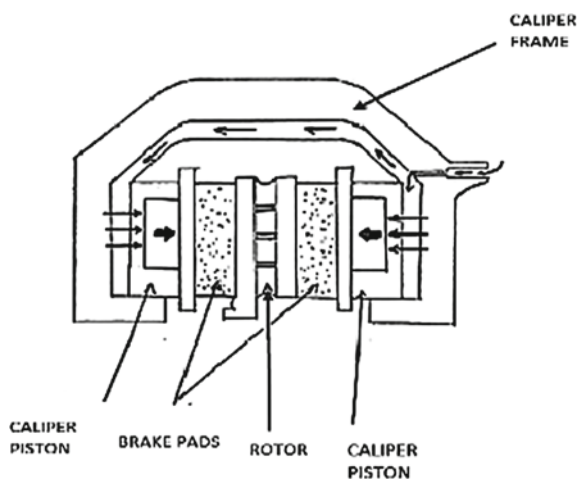

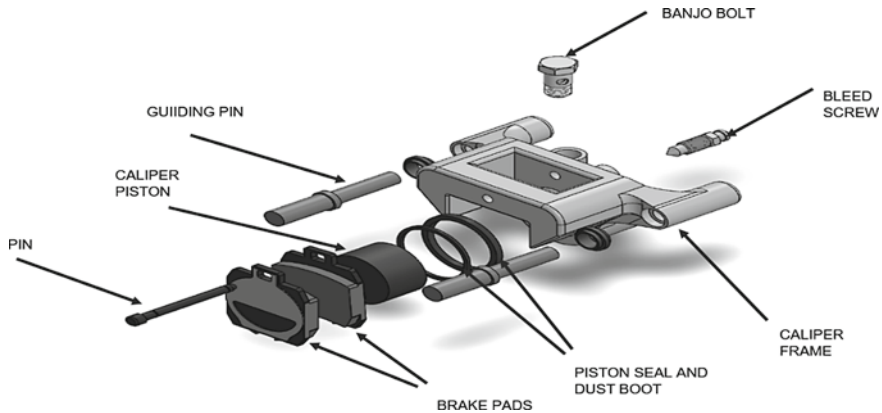

**Fig. 12.4** Components of floating caliper

which is used to create a temporary opening in a closed hydraulic system facilitating the removal of air or any other substance from the hydraulic system through the differences in pressure and density.

In order to have high-performance braking system, it is essential to have an efficiently functioning brake caliper. The efficiency of a brake caliper depends upon few parameters as explained further. The piston diameter should be sufficiently large to produce the required braking force. The hydraulic pressure generated inside the brake caliper should be high enough to ensure that adequate amount of force is applied on the brake pads. The pressure generated should not be lost due to leakages inside the caliper so that there is no pressure loss leading to inadequate clamping action. Removal of air from the hydraulic system is necessary because the presence of air bubbles in the brake system reduces the hydraulic pressure that is developed within the system due to the compressed air. Also, the bleeding screw hole in the caliper should open out at the topmost point of the bore to ensure complete removal of air from the hydraulic system.

The literature was studied to identify the presence of above-mentioned work. Phad et al. [1] studied the design and conducted optimization of brake caliper for the system for maximum performance. Anwana and Cai [2] demonstrated the caliper seal groove design and also established the mechanics behind the deformation of rubber confined to the prescribed boundaries of the seal groove. The force and friction analysis of disc brake and rotor was studied by Mishra et al. [3]. It helps to understand the force and also the amount of friction on the disc brake, and therefore, estimates the efficiency of the disc brake. Maleque and Rahman [4] explained the automotive brake mechanism and suggested that the widely used material is cast iron for the brake rotor. The author emphasized on the substitution of cast iron products by other lightweight materials. An idea to design a brake caliper which is lightweight and provides adequate braking torque required for efficient clamping over the brake disk of the vehicle in hostile racing environments was presented by Bokade and Jade [5]. Khairnar et al. [6] made predictions regarding the critical performance

parameters by taking into consideration the geometric design parameters for the seal groove design. Pishdad [7] focused on the optimization and analysis regarding a heavy-duty caliper and applications of asymmetric designs. According to Limpert [8] the braking force is the most important aspect. The clamping force generated should always be more than the required braking force to slow the vehicle down completely. The research of Amrish [9] was to analyze the different classifications of brake rotors. Brake rotor analysis includes the steady-state thermal analysis and the structural analysis regarding the same. This paper studies the heat dissipation and clamping force based on material variation for drilled disk rotor type brake disk (Negi et al. [10]) after initial testing of the braking setup and its implementation on the vehicle. The overall adjustability of the braking system meets the design goals of possessing better and responsive braking system. The other design objective of achieving minimum stopping distance was also achieved through the redesigned braking system. Doumiat et al. [11] suggested the normal forces and lateral load transfer estimation for the vehicle's safety experimental test. This study introduces the estimated wheel to ground contact normal forces, and also the load transfer effect. The method of testing is proposed based on the dynamic behavior of a vehicle. Vasseljen [12] explained the braking loads developed by a vehicle under sudden deceleration and related thermal analysis for the brake disk to sustain the high temperatures. Also, the integration methods between the caliper and uprights assembly are used for improving in-wheel packing. Grześ [13] aimed to take consideration regarding the temperature fields of the disc rotor during short and emergency braking conditions. This study concluded that in the domain of time the rotating speed of disc along with contact pressure with respect to specific material properties intensely affects the disc brake temperature fields. Pohane and Choudhari [14] discussed the use of finite element model to calculate static structural analysis and transient state analysis. A three-dimensional model of the brake pad and the disc would be required for the aforementioned analysis. Blumberg and Neto [15] explained the methodology for the analysis of the caliper in ANSYS software. This study uses the meshing parameters, regions to be constrained, and the input parameters for the static analysis.

On the basis of literature survey and practical understanding, certain drawbacks of original equipment manufacturer (OEM) caliper have been identified. The bleed screw of the caliper positions downward in direction when mounted on the right side of the vehicle. This increases the difficulty to remove the air bubbles present inside the hydraulic braking system and some air bubbles would remain at the top, and during the bleeding process complete air cannot be removed which causes inefficient braking. Generally, the automobile companies manufacture brake caliper for the left side and the right side separately. This adds up to the machining cost and time for the manufacturing of two separate designs of caliper. Additionally, the fluid entry passage of a brake caliper from the brake hose consists of an intricately drilled pathway which is inclined to all  $X$ ,  $Y$  and  $Z$  axes which makes the drilling process complicated and expensive. Further, due to the complicated geometry of the fluid entry passage, there are high chances of fluid leakage in the caliper leading to failure of the braking system. Also, in such calipers the fluid has to travel a longer distance to reach the caliper piston bore which increases the time taken for clamping action. Importantly,

the OEM calipers have standard piston diameters which does not have the provision of using varying diameter pistons. Due to these problems the braking efficiency of a vehicle is reduced and hence desirable performance like lesser stopping distance and stopping time are not achieved.

The primary objective of this study is to reduce the chances of leakages in the brake caliper and in the braking system and achieve lesser stopping distance and stopping time. The designed brake caliper is intended to have reduced weight with simplified design and geometry in order to decrease the unsprung mass of the vehicle. Also, the proposed study aims to design a caliper such that it can provide intermediate piston diameters according to the working pressure of the fluid and the braking force required to stop the vehicle. The remaining paper is organized as follows: material selection is discussed in Sect. 2, methodology in Sect. 3 and design in Sect. 4. The results are presented and analyzed in Sects. 5, and 6 describes the discussion of the results.

## Material Selection

The selection of material is crucial in order to meet the objectives. The caliper housing material must be rigid enough to sustain all the forces that would occur on it. Also, the material should have a lesser strength to weight ratio to make the caliper lighter. To maintain the required strength in the component aluminum 7075 T6 was selected for the housing with properties as provided in Table 12.1.

The caliper piston material selected was aluminum alloys as the thermal conductivity of aluminum is high ranging between 200 and 250 W/mK. This leads the heat to be transmitted through the piston which was generated due to the friction between rotor and friction pads, causing a fall in disc temperature. Pistons can also be made of titanium or phenol formaldehyde, but are not preferred because of their high cost compared to aluminum. To have a safe and efficiently functional braking system, it is necessary to have brake pads or friction materials with high coefficient of friction which is independent of temperature effects, velocity, pressure, wear, ambient conditions and corrosion. The friction material also has to be environment-friendly and of low cost. To satisfy these parameters we selected OEM metal composite brake pads with properties as shown in Table 12.2.

The piston seal is placed inside the bore of the caliper, and the factors like its compatibility with brake fluid, operating temperature range, fluid pressure sustainability range, hardness, working conditions, tensile strength, compressibility and failure modes are crucial considerations. Various materials available for seals are

**Table 12.1** Properties of aluminum 7075 T6

Mechanical properties	Yield strength	Modulus of elasticity	Poisson's ratio
Values	503 MPa	71.7 GPa	0.33

**Table 12.2** Brake pad properties

Modulus in compression	830 MN/m <sup>2</sup>
Ultimate shear strength	11 N/m <sup>2</sup>
Thermal conductivity	5796 Nm/hkm
Brinell hardness	14
Friction coefficient	0.35
Unit pressure	0.35–5.2 MN/m <sup>2</sup>

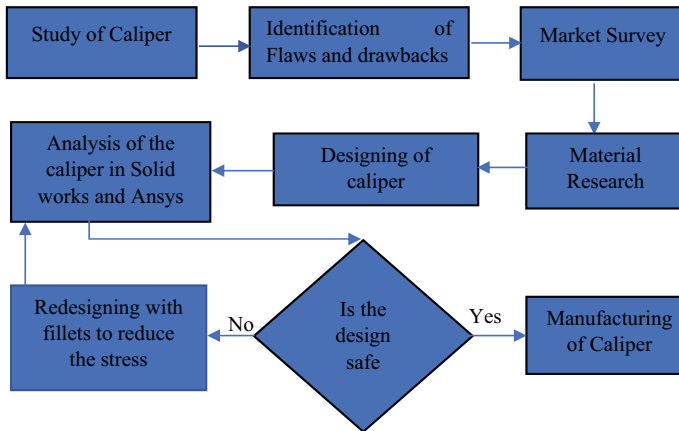

**Fig. 12.5** Methodology of proposed system

thermoplastic elastomers, rubber, rigid thermoplastics, and so on. Considering the properties of the brake fluid, rubber is the best suited material for the seals. It can operate up to 150 bar and can work within the range of  $-40$  to  $130$  °C having tensile strength up to 13 MPa.

## Methodology

The methodology followed to implement the proposed system is shown in Fig. 12.5.

## Design

The 3D model of a caliper as shown in Fig. 12.6 is created using the software SolidWorks 2016. The fluid entry port of the caliper is introduced directly into the bore of the caliper piston with a horizontally drilled pathway parallel to X-axis in order to simplify the geometry of the fluid entry port. The bleeding valve is positioned

**Fig. 12.6** CAD model of caliper

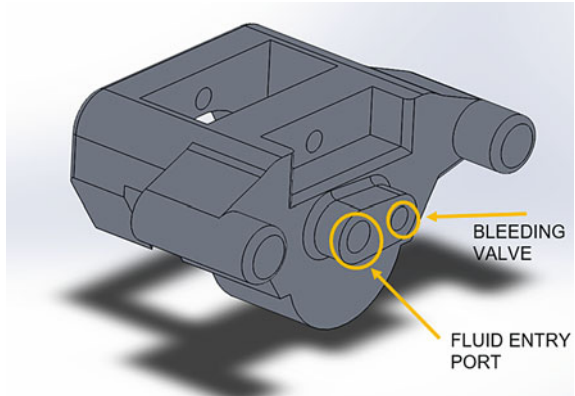

in the center to ensure that the bleed screw will not position in the downward direction irrespective of its mounting position. The caliper is designed in such a way that it can accommodate a piston bore of diameter ranging from 28 to 38 mm.

## Results and Analysis

### *Calculations*

The following calculations are done for designing the brake system. These calculations validate that the caliper design meets the necessary requirements. While braking, the generated braking torque on the rotor must be greater than the torque on the wheel due to weight transfer for efficient braking action.

Calculation of braking torque requirement:

$$\text{Weight transfer: } W_T = (H/L) * (W/g) * \mu * g$$

$$\text{Dynamic load: Front } W_{FD} = \text{Front Static load} + W_T$$

$$\text{Rear } W_{RD} = \text{Rear Static load} - W_T$$

$$\text{Required braking force and torque: } B_F = \mu_g * W_{FD} \quad (12.1)$$

$$B_T = B_F * \text{wheel diameter} \quad (12.2)$$

Calculation of generated braking torque:  $F_{mc} = F_{p1} * \text{pedal ratio}$



$$P_{Mc} = F_{mc} / A_{mc}$$

$$P_{mc} = P_{caliper}$$

$$F_{caliper} = P_{caliper} * A_{caliper}$$

Generated braking force and torque:  $F_{disc} = \mu_{pad} * F_{caliper}$  (12.3)

$$B_{TF} = F_{disc} * Radius_{disc}$$
 (12.4)

The braking torque that we get from Eq. (12.4) must be greater than that of the braking torque from Eq. (12.2) for effective braking action.

Design calculations were carried out for an ATV vehicle having kerb weight 250 kg. The parameters like static load of vehicle, wheel base, height of center of gravity are required for designing. Table 12.3 presents the design input variables. The master cylinder selected is Bosch tandem master cylinder having a bore diameter of 19.07 mm. The comparison of braking torque for above calculations is presented in Table 12.4.

The caliper designed has a piston diameter of 32 mm which produces sufficient torque necessary to stop an ATV of kerb weight 150 kg. But the caliper is designed in such a way that it can have a maximum of 38 mm diameter piston bore. Hence

**Table 12.3** Design input parameters

Parameters		Value
Weight of vehicle (including driver's weight)		250 kg
Static load	Front	103.5 kg
	Rear	116.5 kg
Wheel base		54 inch
CG height		19.97 inch
Coefficient of friction between tires and road surface		1
Pedal ratio		8:1
Master cylinder bore diameter		19.07 mm
Disc diameter	Front	165 mm
	Rear	180 mm
Coefficient of friction between the pad and the disc		0.35
Pedal force		300 N
Caliper piston diameter		32 mm

**Table 12.4** Comparison of braking torque for above calculations

Braking torque	Required braking torque (Nm)	Generated braking torque (Nm)
Front	265.275	343.00
Rear	100.85	413.910

**Table 12.5** Braking torque (Nm) of motorcycle

Master cylinder bore diameter (mm)	Caliper piston diameter (mm)			
	30	32	34	38
12.7	535.6811	609.486	688.05258	859.4705
15.87	343.0519	390.3169	440.63117	550.4078
19.07	237.5814	270.3148	305.16005	381.1861
25.4	133.9203	152.3715	172.01314	214.8676

**Table 12.6** Braking torque (Nm) of car

Master cylinder bore diameter (mm)	Caliper piston diameter (mm)			
	30	32	34	38
12.7	468.7209	533.3003	602.046	752.0367
15.87	300.1705	341.5273	385.55227	481.6068
19.07	207.8837	236.5254	267.01505	333.5378
25.4	117.1802	133.3251	150.5115	188.0092

it can produce greater torque which is enough to stop a vehicle of maximum kerb weight of 1000 kg. Tables 12.5 and 12.6 show the required braking torque to stop a vehicle and the braking torque provided by the designed caliper. Design calculations for motorcycle of kerb weight of 180 kg and braking torque of 360–400 Nm are shown in Table 12.5. Whereas calculations for a car of kerb weight of 1000 kg and a braking torque between 800 and 600 Nm are shown in Table 12.6.

## *Analysis*

In order to do analyze, the following properties of material were given as input to the software. The analysis of the CAD model of the caliper is done by varying the values of force and pressure. Software Ansys 18.1 is used to study the static structural analysis of the CAD model.

Material: Al 7075 T-6  
 Density: 2700 kg/m<sup>3</sup>  
 Young's modulus: 72 GPa

**Fig. 12.7** Meshing of caliper

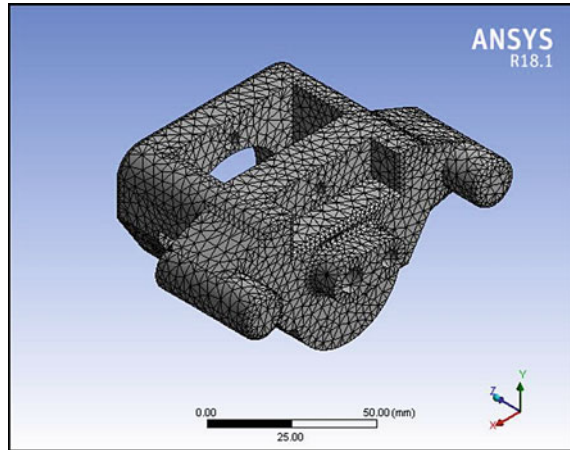

Ultimate tensile strength: 590 MPa.

Figure 12.7 shows the meshing of the caliper, and by using the default settings mesh quality (i.e., a coarse mesh with element size = 4 mm) 0.619 was obtained.

The body of the caliper is subjected mainly to two loads that are: (a) Force on the caliper due to the pressure applied at the back of the piston and (b) force on the caliper body due to clamping. Considering vehicle mass as 250 kg, weight distribution of 45% at front and 55% at rear, pressure force of piston area of 8.4 MPa, clamping force of 3000 N at the end of opposite pad and having a fixed support at the two mounting positions.

The design of caliper has FOS 2.1, total deformation is 0.9 mm, minimum equivalent stress is 0.02536 MPa. The results obtained from the analysis with ANSYS Workbench are as shown in Figs. 12.8 and 12.9.

After designing we machined the caliper with CNC machining. The machined caliper is then set up in a front/rear split brake system on a BAJA ATV for bleeding. The other brake components used are:

- Master cylinder—Bosch TMC (19.07 mm bore diameter, 30 mm stroke length)
- Brake hose—Stainless steel braided Teflon brake hose (5 mm inner diameter)
- Brake disc—SS 420 (front diameter 165 mm, rear diameter 180 mm)
- Pedal—Al 7075 pedal ratio 8:1.

### ***Iterations***

Several iterations were made to overcome the drawbacks faced during the bleeding of the caliper.

**Fig. 12.8** Deformation

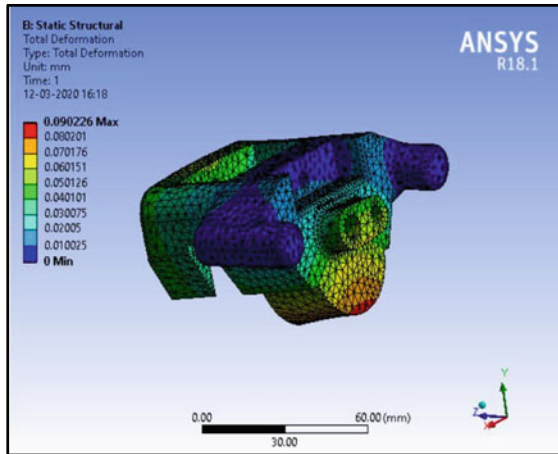

Total Deformation is 0.9 mm

**Fig. 12.9** Equivalent stress

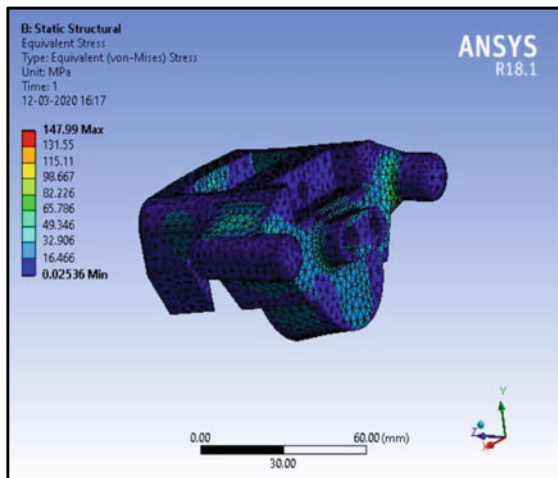

Min Equivalent stress is 0.02536 M Pa

Iteration 1:

The oil leaked from the piston bore during the bleeding process. This was because the oil seal rings could not properly accommodate the seal grooves. Hence the oil seal rings did not perform its function of preventing the oil leakage. Also, another function of the seal is to retract the piston backwards, which was not performed due to improper machining of the grooves.

Result: Improper clamping action.

Action Taken: Machining of grooves with proper tolerances.

**Fig. 12.10** Caliper mounted on gearbox (inboard braking)

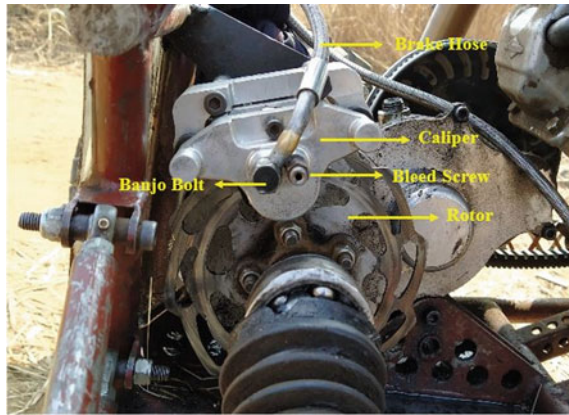

#### Iteration 2:

After designing the grooves with adequate tolerances, there were no leakages in the caliper. Also, the new caliper is designed such that the movements of brake pads are guided properly for clamping of the discs. Figure 12.10 shows the final design of caliper in rear inboard braking system of an ATV.

After bleeding the brake system, the vehicle was tested to run 150 ft on concrete surface for validating the stopping distance.

## Discussion

In the modified vehicle, custom brake caliper mountings can be incorporated based on upright assembly for different types of vehicle. Compactness of the model can be achieved so that in-wheel packing is easier and no hindrance to other subsystems is formed. According to the total curb weight of the vehicle, the modifications for the piston bore according to standard piston diameter can be adjusted. Just by keeping the main design as the same on each caliper and just by varying the piston diameter the caliper can be used for every type of vehicle segment (SUV, Hatchback, etc.). Taking into consideration the weight transfer of the vehicle, a compact brake disk having lesser diameter can be employed. By this method the required braking force can be achieved and excess forces are not developed so that it can lock the wheel immediately and cause the vehicle to skid. Also, as the system is made compact the total assembly weight is made less. By this, the unsprung mass of the vehicle at each individual wheel is reduced and the vehicle performance is not compromised. Furthermore, the handling characteristics of vehicle is not compromised when vehicle goes into bumps and droops. The bleed screw positioning is made such that complete air bubbles trapped in the system can be evacuated easily. And flow of air bubbles out of the system is faster so that bleeding process can be faster and clamping performance of the caliper is improved.

Material selected is Al-7075 T-6 for the caliper and SS-420 for brake disk. The specific gravity as well as cost is less and the performance is enhanced as lightweight assembly is designed. Also, the material chosen has good corrosion resistance and thus has longer lifespan. The proposed model is thus better than the available OEM and offers many benefits. The brake caliper bleed screw has been positioned upwards to facilitate easier for bleeding process. The piston diameter can be varied according to the required braking force for complete braking. The weight of the redesigned caliper is lesser than the OEM caliper of the same piston diameter. Due to the reduced weight of the caliper, the unsprung mass of the vehicle also reduces. This indirectly increases the stability of the vehicle. By using this caliper model, the time required for assembly of caliper is reduced.

## Conclusion

The design goal of the caliper model is to improve the braking efficiency of the system by making design changes in the geometry of the banjo valve and bleed screw valve. By employing a seal groove which has perfect tolerance the brake fluid won't exit the main piston chamber which would reduce the chances of leakage in the caliper. By using aluminum 7075-T6 as the standard material for manufacturing, the overall weight of the assembly would reduce, which would make the unsprung mass of the vehicle to reduce and the vehicle performance would not be restrained. The lightweight and compact design helps in improving the vehicle performance and stability. Based on the mounting points for the caliper on the vehicle upright, the caliper system can be easily modified so that serviceability is made easy and is less time-consuming. The simplified design of the caliper enables easy assembly and disassembly of the component. The calculated stopping distance of the vehicle was validated by testing it on concrete surfaces. The stopping distance achieved was 2.9 m. The designed caliper is suitable to be used in any motorcycle or any lightweight four-wheeler. This caliper can be easily used in any BAJA SAE vehicle due to its compliance with the design of the vehicle. In the proposed model the designed caliper can only be used for a vehicle with maximum kerb weight of 1000 kg. Beyond this weight, the caliper will be incapable of providing complete braking. With the designed caliper, a maximum of 38 mm piston diameter can be achieved. The caliper is manufactured with the process of CNC machining which is a relatively expensive process. The CNC machining does not ensure proper groove geometry to be machined in the caliper frame. This causes improper retraction of the piston by the seal. The piston seals are available only in diameter as per the OEM caliper diameter. Hence, there are no seals available for piston diameters other than the standard ones. This causes a problem in having the desired piston diameters of the caliper. With further modifications in caliper, like changing the dimensions of the caliper or increasing the number of pistons, the caliper can be used for heavier vehicles. With further advent in the manufacturing process due to mass production, the designed brake caliper can be die-casted. This process provides more strength to the caliper, reduces

the machining cost and ensures proper seal groove geometry. Further, an electronic brake distribution (EBD) system can be used to vary the amount of force applied on each wheel. Hence, providing adequate clamping action in each wheel.

## References

1. Phad D, Auti T, Joshi R (2015) Design and analysis of a Brake Caliper. *Int J Automob Eng Res Dev* 5(5):1–10
2. Anwana OD, Cai H, Chang HT (2002) Analysis of brake caliper seal-groove design. *SAE Trans* 111:1316–1324
3. Mishra YH, Deulgaonkar VR, Makasare PA (2015) Design and optimization of disc brake rotor (for two wheeler). *Int Eng Res J* 288–300
4. Maleque MA, Dyuti S, Rahman MM (2010) Material selection method in design of automotive brake disc. In: Ao SI, Len Gelman and David WL Hukins and Andrew Hunter Korsunsky AM (eds) *The 2010 international conference of computational intelligence and intelligent systems. Proceedings of the world congress on engineering WCE London, UK*, 3:2322–2326
5. Bodake A, Jade A (2018) Optimisation of hydraulic brake caliper of all-terrain vehicle. *Int J Sci Eng Res* 9(12):523–530
6. Khairmar HP, Phalle VM, Mantha SS (2017) Frictional coefficient depending on active friction radius with BPV and BTV in automobile disc braking system. *Int J Eng, Sci Technol* 9(3):41–50
7. Pishdad AR (2012) *Advanced design of brake calipers*. Politecnico di Milano, Italy
8. Limpert R (2011) *Brake design and safety, Edition III*. SAE International
9. Amrith PN (2016) Computer aided design and analysis of disc brake rotors. *Adv Automob Eng* 5(2):1–13
10. Negi V, Deshmuk N, Deshpande A (2017) Design of braking system of BAJA vehicle. *Int J Adv Eng Res Dev* 4(11):1059–1064
11. Doumiati M, Victorino A, Charara A, Lechner D (2009) Lateral load transfer and normal forces estimation for vehicle safety: experimental test. *Veh Syst Dyn: Int J Veh Mech Mobil* 47(12):1511–1533
12. Vasseljen B (2018) Brake caliper design for a formula student race car-on behalf of revolve NTNU. NTNU
13. Grześ P (2009) Finite element analysis of disc temperature during braking process. In: Viadero F, Ceccarelli M (eds) *New trends in mechanism and machine science* 3(4):36–42
14. Pohane R, Choudhari RG (2011) Design and finite element analysis of disc brake. *Int J Eng Res Ind Appl* 4(1):147–151
15. Blumberg R, Neto NF (2010) Design of high performance automotive brake caliper using ANSYS. Paper presented at ANSYS South American conference and esss users meeting, Atibaia SP, Brazil, 19–22 Oct 2010