

Chapter 27

MATLAB-Based Comparative Analysis of Alternative PV Models



Khamma Kanwar and Jayashri Vajpai

1 Introduction

In the recent decades, Solar Photovoltaic (PV) systems have become the fastest-growing alternative source of energy. These systems are environment friendly and require less maintenance. Photovoltaic effect converts the solar radiation into the electrical energy in solar cells. PV arrays have number of cells in series and parallel or a group of panels. PV systems require little maintenance and are pollution free. PV systems have standalone and grid connected applications such as, light sources, battery charging, solar water pumping stations, hybrid vehicles, military and satellite systems [1].

The nonlinear characteristic of PV cell can be modeled on the basis of Shockley equation. Both single diode and double diode models are commonly used to simulate PV characteristics. The single diode model simulates the PV cell characteristics accurately. The efficiency of the solar energy conversion is directly related with the maximum power extraction (MPP) from the PV system [2].

MPP is based on realizing the dynamic or static method of optimization. In the dynamic method, the MPP is achieved by tracking of position and movement of the sun. This approach may not be suitable for energy conversion at a small to medium power range due to its high cost and energy consumption. In the static method (for small power range), the MPP is tracked with the help of DC–DC converter by adjusting continuously the operating point. In the literature, many methods have been reported to track the MPP of PV generator. The Perturb and Observe (P&O) method is widely used approach for tracking MPP [3].

K. Kanwar · J. Vajpai (✉)
M. B. M. Engineering College, Jai Narain Vyas University, Jodhpur, India
e-mail: jvajpai@gmail.com

K. Kanwar
e-mail: kkjoya.jnvu@gmail.com

Table 1 Comparison of datasheet parameter of three different PV systems

	Mathematical model	Inbuilt PV array	User-defined PV array
Model	KC200GT	KC200GT	KC200GT
Maximum Power [W]	200.143	200.143	200.143
Open circuit voltage V_{oc} [V]	32.9	32.9	32.9
Short circuit current I_{sc} [A]	8.21	8.21	8.21
Voltage at MPP V_{mp} [V]	26.3	26.3	26.3
Current at MPP I_{mp} [A]	7.61	7.61	7.61
Diode saturation Current I_0 [A]	9.825×10^{-8}	$2.3246e^{-10}$	$8.9892e^{-16}$
Open-circuit voltage/temperature coefficient K_V [V/K]	-0.1230	-0.35502	-0.1230
Short-circuit current/temperature coefficient K_I [A/K]	0.0032	0.06	0.0032
Ideality constant a	1.3	0.97736	0.64611
Shunt resistance R_p [Ω]	415.405	150.6921	65.4647
Series resistance R_s [Ω]	0.221	0.34483	0.47804
Number of cell in series N_s	54	54	54

Over the last decades, many researchers have studied the characteristics of PV array by using simulation approach. Nguyen and Nguyen [4] have explained the step by step procedure of mathematical modeling of PV array in MATLAB/SIMULINK under different environment condition. Villalva et al. [5] have developed mathematical model to find out the best I–V equation for PV array by adjusting the I–V curve at three points, viz., open circuit voltage (V_{oc}), MPP and short circuit current (I_{sc}). Bouraiou et al. [6] have presented mathematical modeling of one diode and two diode models of PV array and carried out simulation under different temperature and irradiance conditions. The two algorithms have been compared experimentally by Houssamo et al. [7] to maximize the output power from a PV system for the given set of conditions using inbuilt PV array block in MATLAB. AbdelHady [8] has used the inbuilt PV array and developed a MATLAB Simulink model that evaluates the system performance when it is tied either with local grid or National grid. Some of the researchers have used inbuilt PV array block and others have developed the mathematical model of PV array. However, none of them has discussed which model gives the best response.

In this paper, the mathematical model of PV array has been simulated in MATLAB/SIMULINK on the basis of model equation. Then comparison of manufacture datasheet parameters and output response is made between the developed mathematical PV array model and inbuilt PV array block available in MATLAB/SIMULINK in order to verify the accuracy of the inbuilt model.

2 Methodology

The proposed comparative analysis of alternative PV models is carried out in the following subsections.

2.1 Mathematical Modeling of PV Array

An overview of PV system is shown in Fig. 1 [3]. It consists of PV array along with DC–DC Power converter that is connected to a PWM generator driven by MPPT algorithm.

The four parameters model equivalent circuit diagram of PV array comprises of a current source, a diode, a series resistance and a parallel resistance. The antiparallel diode with the photo current source represents the theoretical model of ideal PV cell. I–V characteristics may be expressed as follows [6]:

$$I = I_{pv} - I_0 \left[\exp\left(\frac{V + IR_s}{V_t a}\right) - 1 \right] - \frac{(V + IR_s)}{R_p} \tag{1}$$

where

- I_{pv} Photocurrent (A)
- I_0 Diode saturation current (A)
- $V_t = N_s k T / q$ Thermal voltage of the array
- N_s Number of cells connected in series
- q Electron charge ($1.60217646 \times 10^{-19} \text{C}$)
- k Boltzmann constant ($1.3806503 \times 10^{-23} \text{J/K}$)
- T Module operating temperature (K)
- a Diode ideality constant
- R_s Series resistance(ohm) and
- R_p Parallel resistance (ohm)

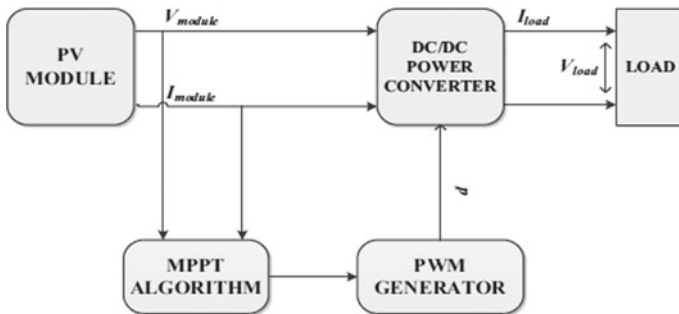

Fig. 1 Overview of PV system [3]

The photocurrent of the PV cell depends linearly on the solar irradiation and temperature according to the following equation:

$$I_{pv} = (I_{pv,n} + K_I \Delta T) \frac{G}{G_n} \quad (2)$$

where $I_{pv,n}$ photo current at the nominal condition generally 25 °C and 1000 W/m²,
 $\Delta T = T - T_n$

T_n Nominal temperatures (K)

G Irradiation on the device surface (W/m²), and

G_n Nominal irradiation

The diode saturation current is described by:

$$I_0 = \frac{I_{sc,n} + K_I \Delta T}{\exp\left(\frac{V_{oc,n} + K_V \Delta T}{aV_t}\right) - 1} \quad (3)$$

$I_{sc,n}$ Short circuit current at nominal condition (A)

$V_{oc,n}$ Open circuit voltage at nominal condition (V)

K_V Open circuit voltage/temperature coefficient K_V [V/K]

K_I Short circuit current/temperature coefficient K_I [A/K]

Using these equations, the mathematical model of PV array has been developed in MATLAB in many papers. The mathematical equation-based model of PV array is simulated in this paper for the purpose of comparison.

2.2 Maximum Power Point Tracking

The I–V characteristics of PV array are nonlinear and show unique MPP under a particular set of environment conditions, and this peak point keeps changing with solar irradiation and ambient temperature. The efficiency of PV systems is generally very low. For improvement of efficiency, the PV source impedance should match with the load impedance for every operating condition, thereby requiring Maximum power point tracking (MPPT) which optimizes the operating point [6].

The maximum power is set by adjusting the Duty Cycle of DC-DC converter. The MPP can be tracked by various algorithms like:

- Perturb and observe (P&O) method
- Incremental Conductance method
- Short circuit current method
- Open circuit voltage method
- Ripple correlation control method

P&O method is the most widely used MPPT technique on account of simplicity, easy implementation and effectiveness.

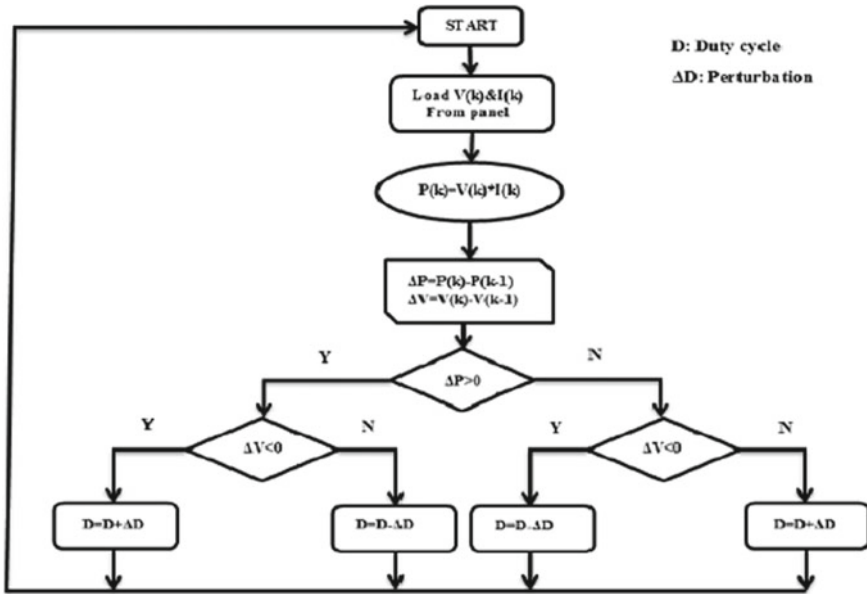

Fig. 2 The flowchart of the P&O algorithm[8]

Perturb and Observe—In this approach, the voltage from the array is adjusted in small bidirectional steps by the controller to observe the changes in the output power. Further adjustments are done in the direction in which the power increases. However, the P&O method can result in oscillations of power output due to the rise and fall of the curve of power against voltage below the MPP [7]. The flowchart of P&O algorithm is shown in Fig. 2 [8]

2.3 Modeling of DC/DC Converter

DC/DC converter is employed to convert a fixed voltage DC source into a variable-voltage DC output. It provides high efficiency, good acceleration control and fast dynamic response. There are mainly four basic topologies such as boost converter, buck converter, buck-boost converter and Cuk converter [9]. However, since the objective of this research work is comparison of models, the boost converter topology has been employed for simplicity. The input and output voltage relationship can be represented by following equation:

$$V_{out} = \frac{1}{1 - D} V_{in}$$

Here D is Duty Cycle, V_{in} is input voltage and V_{out} is output voltage.

3 Simulation in MATLAB/SIMULINK

The following table compares datasheet parameters of 200 W PV array model KC200GT with MATLAB inbuilt PV array block and user-defined model that have same reference parameters as per datasheet like maximum power, open circuit voltage, short circuit current, voltage and current at MPP and number of cells in series but remaining parameters are different. In user-defined model, there is provision to define parameters but some parameters are fixed and some parameters can be defined as per as datasheet. The mathematical model is developed in the preceding section using the manufacturer datasheet parameters. It is expected that proper selection of model may further improve the performance of model KC200GT.

3.1 Mathematical Modeling of PV Array in MATLAB/SIMULINK

In this research work, MATLAB software has been used to implement the equation of PV cell for developing a mathematical model of PV array KC200GT as shown in Fig. 3. This model was designed for supplying maximum power to resistive load with MPPT under particular environment conditions using Simulink blocks (Fig. 4).

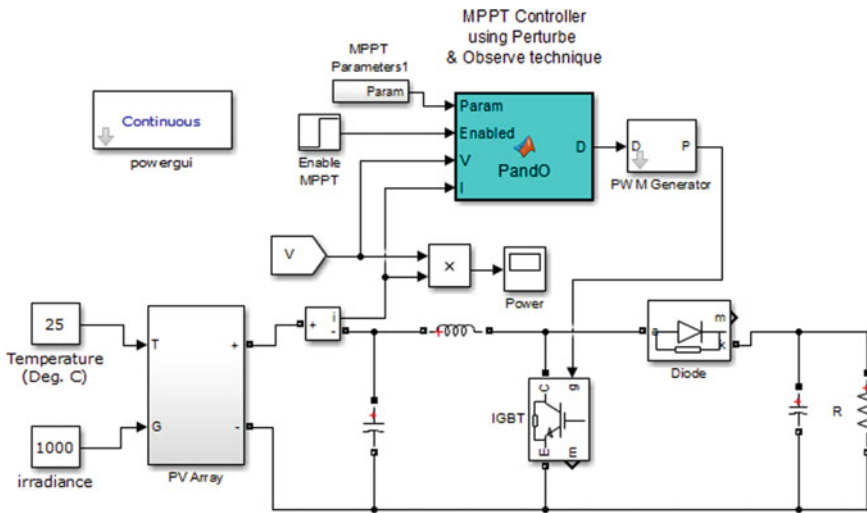

Fig. 3 MATLAB/Simulink model developed by employing mathematical equations of PV system

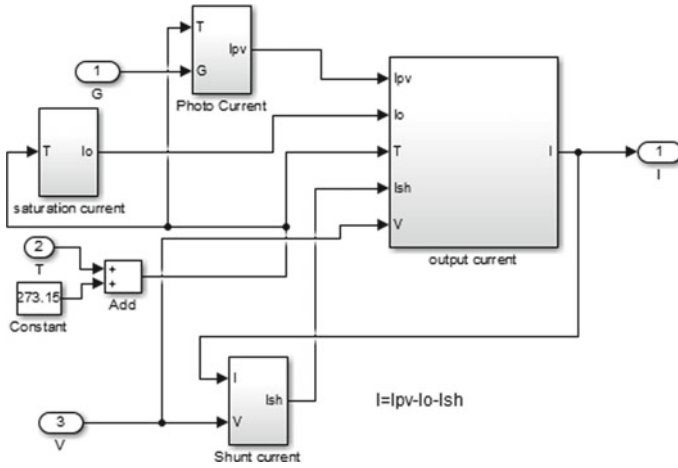

Fig. 4 Subsystem of PV array

3.2 Inbuilt PV Array Block Available in MATLAB/SIMULINK

The simulation was also carried out using the inbuilt PV array block model KC200GT already available in MATLAB as shown in Fig. 5. The operating conditions were designed for giving maximum power to the resistive load with MPPT. In this block, some parameters are different from datasheet. Hence it is implemented by employing

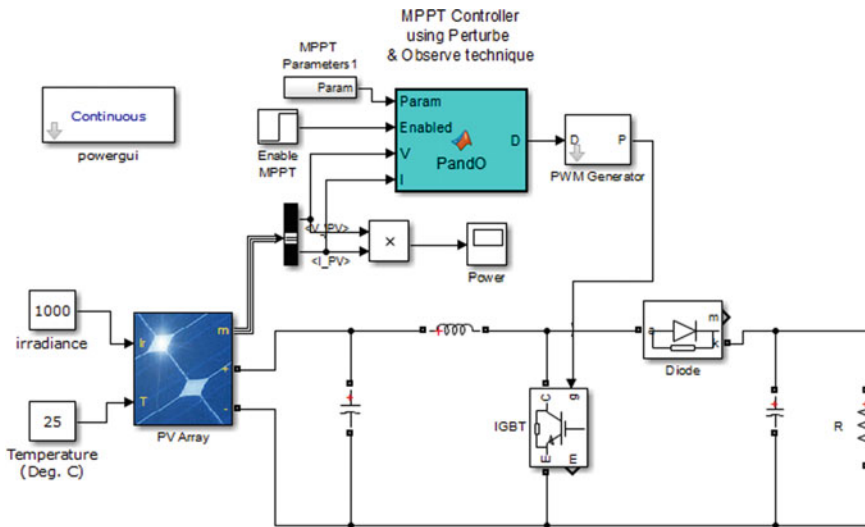

Fig. 5 PV system using Inbuilt PV array block

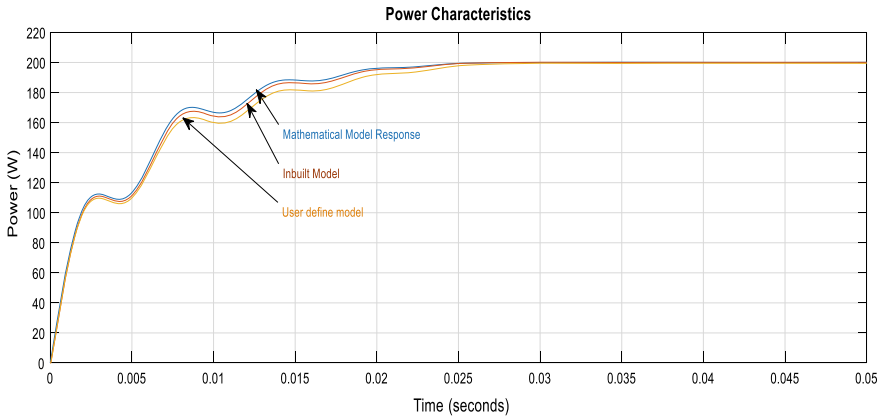

Fig. 6 Output power characteristics of three different systems

the user-defined model. The performance of the developed mathematical model is compared with the inbuilt PV array block model and user-defined PV models.

3.3 Simulation Results

The simulation is done for the three different systems as follows: In the first system, the PV model is implemented using mathematical equations in Simulink. In the second system, the PV model is implemented using inbuilt PV array block. In the third system, PV model is implemented using user-defined block. The simulated system output power characteristics are shown in Fig. 6.

It was found that the performance of PV model developed by using mathematical equations is better than the system designed by inbuilt PV array model and user-defined model.

4 Conclusions

The three different models of PV array KC200GT have been implemented in MATLAB Simulink. Then comparative analysis of datasheet parameters of these three different models of PV array has been carried out. The P&O algorithm is used for giving the maximum power to the constant load with the help of boost converter. The power characteristics obtained by mathematical equation-based modeling of PV array gives better result than remaining two models. It is expected that this comparative analysis will be useful for designing accurate models for research purpose.

References

1. Rahim KNA, Ping HW, Selvaraj J (2012) Photovoltaic module modeling using simulink/matlab. In: The 3rd International Conference on Sustainable Future for Human Security SUSTAIN, vol 17, pp 537–546. Elsevier (2013). <https://doi.org/10.1016/j.proenv.2013.02.069>
2. Surya Kumari J, Sai Babu Ch (2012) Mathematical Modeling and Simulation of Photovoltaic Cell using Matlab-Simulink Environment. *Int J Electr Computer Engineering (IJECE)* 2(1): 26–34, ISSN 2088-8708
3. Jazayeri M, Uysal S, Jazayeri K (2014) Evaluation of Maximum Power Point Tracking Techniques in PV Systems using MATLAB/Simulink, Sixth Annual IEEE Green Technologies Conference, pp 54–60. IEEE computer society. <https://doi.org/10.1109/GREENTECH.2014.21>
4. Nguyen XH, Nguyen MP (2015) Mathematical modeling of photovoltaic cell/module/ arrays with tags in Matlab/Simulink. <https://doi.org/10.1186/s40068-015-0047-9>
5. Villalva MG, Gazoli JR, Filho ER (2009) Comprehensive Approach to Modeling and Simulation of Photovoltaic Arrays, *IEEE TRANSACTIONS ON POWER ELECTRONICS*, 24, NO. 5, pp. 1198-1208, 2009. <https://doi.org/10.1109/tpel.2009.2013862>
6. A. Bouraiou, M. Hamouda, A. Chaker, M. Sadok, M. Mostefaoui, S. Lachtar: Modeling and Simulation of Photovoltaic Module and Array based on One and Two Diode Model Using Matlab/Simulink
7. I. Houssamo, F. Locment, M. Sechilariu: Experimental analysis of impact of MPPT methods on energy efficiency for photovoltaic power systems, Elsevier *Electrical Power and Energy Systems*, VOL. 46 pp. 98–107, <http://dx.doi.org/10.1016/j.ijepes.2012.10.048>
8. R. AbdelHady: Modeling and simulation of a micro grid-connected solar PV system, science direct water science, VOL. 31, pp. 1–10, 2017, <http://dx.doi.org/10.1016/j.wsj.2017.04.001>
9. Esram T, Chapman PL (2007) Comparison of Photovoltaic Array Maximum Power Point Tracking Techniques. *IEEE Trans Energy Convers* 22(2):439–449. <https://doi.org/10.1109/TEC.2006.874230>
10. A. Kumars, K. L. Ratnakar, B. S. Yogananda and B. R. Kamath.: Simulation of Photovoltaic Cell and MPPT Controllers and their Analysis, *International Journal of Engineering Science and Innovative Technology (IJESIT)* Vol. 4, pp. 253–263, 2015
11. Badii G, Ali H, Othman H, Rachid D (2014) Experimental Study of MPPT Algorithms for PV Solar Water Pumping Applications. <https://doi.org/10.5339/qfarc.2014.ITSP0107>
12. Saoud MS, Abbassi HA, Kermiche S, Ouada M (2013) Improved incremental conductance method for maximum power point tracking using cuk converter, *WSEAS Trans Power Syst* 8(3)