

# Implementation of a preamplifier-amplifier system for radiation detectors used in Mössbauer spectroscopy

A. A. Velásquez · M. Arroyave

Published online: 12 February 2013

© Springer Science+Business Media Dordrecht 2013

**Abstract** We report the assembly and testing of a preamplification and amplification system for pulses produced by gaseous radiation detectors commonly used in Mössbauer spectroscopy. The system is composed by a pair of commercial integrated circuits A203 and A206, which operate as charge sensitive preamplifier-shaping amplifier and linear amplifier-low level discriminator, respectively. The integrated circuits were interconnected in the unipolar output mode and placed inside a metallic shielding, which prevents noise amplification for a suitable signal-noise ratio. The system was tested by irradiating a proportional counter LND-45431 with characteristic X rays of 6.3 keV and gamma rays of 14.4 keV emitted by a Mössbauer radioactive source of  $^{57}\text{Co}$  (Rh). Unipolar pulses with Gaussian profile were obtained at the output of the linear amplifier, whose amplitudes were close to 0.4 V for 6.3 keV X rays and 1.4 V for 14.4 keV gamma rays. Pulse height spectra showed that the system allows a satisfactory identification of the X-rays and gamma rays emitted by the  $^{57}\text{Co}$  source, giving the possibility to make a good selection of the 14.4 keV peak for having a suitable signal-noise ratio in the Mössbauer spectra. Absorption percentages of 14 % were found by taking the Mössbauer spectra of a natural iron absorber. The assembly and tests of the system are presented through this paper.

**Keywords** Mössbauer spectroscopy · Preamplifier and amplifier system · Radiation detectors

---

Thirteenth Latin American Conference on the Applications of the Mössbauer Effect, LACAME 2012, Medellín, Columbia, 11–16 November 2012.

A. A. Velásquez (✉) · M. Arroyave  
Grupo de Electromagnetismo Aplicado, Universidad EAFIT, A. A 3300, Medellín, Colombia  
e-mail: avelas26@eafit.edu.co

## 1 Introduction

Pulse amplifiers play an important role in the signal conditioning systems used in spectrometry experiments, such as radiation gaseous detectors and solid state detectors [1–3]. The main function of these electronic systems is to convert in electrical pulses the electrical charges collected in the electrodes of the detectors after an ionizing event. The physical phenomenon that gives rise to the generation of electric charge inside the detector depends on the type of detector, as well as the energy of the incident radiation, being the photoelectric effect the main phenomenon exploited in the gaseous detectors, the production of electron–hole pairs exploited in the semiconductor detectors and the emission of fluorescent radiation exploited in the scintillation detectors. For certain ranges of energy and operating voltage, characteristics of each detector, the total charge generated by the interaction between the radiation and the material of the detector is proportional to the energy carried by the incident radiation. In order to obtain the best advantage of this sensing property is necessary to select a convenient amplification system, with the lowest possible noise level.

In an effort to develop efficient and low cost systems to satisfy the particular needs of our Mössbauer laboratory, we made the assembly of a preamplifier–amplifier system based on a charge sensitive preamplifier A203 and a linear amplifier A206 supplied by Amptek Inc. The integrated circuit A203 was connected in the unipolar mode to the output terminal of a proportional counter LND-45431, looking for the best ratios of voltage-charge and signal-noise for the output pulses. The linear amplifier A206 was connected in cascade with the A203 in order to obtain additional amplification. The whole system allowed us to obtain pulses with Gaussian profile, whose amplitudes are in the scale of 1 V, which were suitable for the pulse discriminator and single channel analyzer modules of our Mössbauer spectrometer. The system has a modular structure, allowing easy monitoring of the signals. The details of the circuit and the testing of the system are presented through this paper.

## 2 Experiment

### 2.1 The detection system

The system used for the detection of ionizing radiation is a gaseous proportional counter LND-45431 developed by LND, INC. [4]. The counting gas of this detector is 97 % Kr and the quenching gas is 3 % CO<sub>2</sub>, the internal pressure of the mixture is 800 Torr. The detector has an aluminum case and a beryllium window for the entry of the radiation. The high voltage applied to the electrodes of the detector was of 1.5 kV, which was supplied by a high voltage source Wissel, model HVS2 with range of 3 kV. The incidence of ionizing radiation over the detector generates, via photoelectric effect, primary electron-ion pairs, which are accelerated by the high voltage in opposite directions towards the electrodes of the detector. During their travel towards the anode, the primary electrons produce secondary ionizations in the filling gas, which amplify by a factor close to 10<sup>5</sup> the charge generated in the primary ionization.

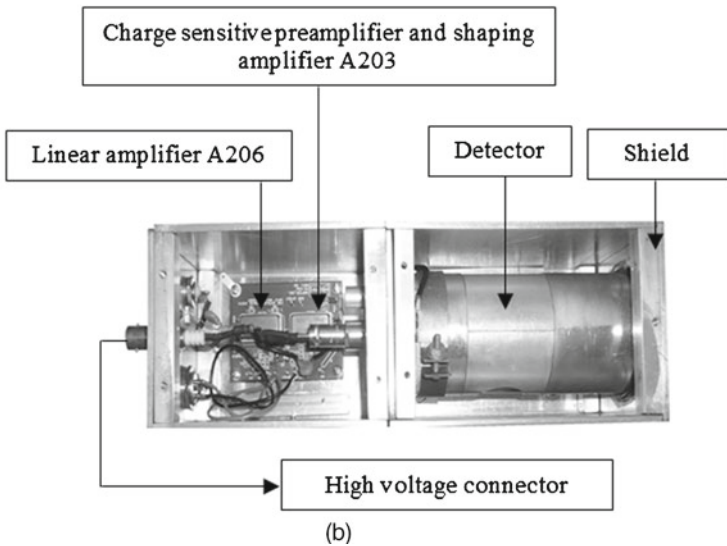
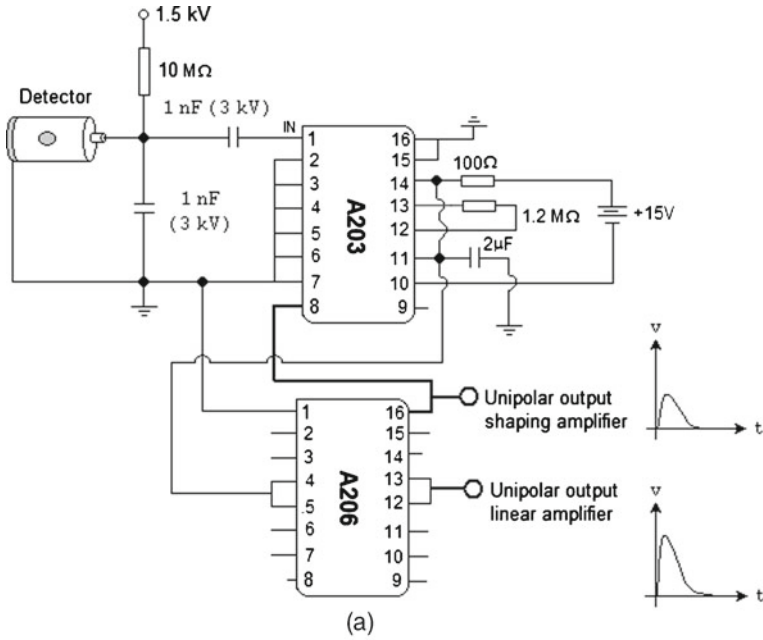

**Fig. 1** **a** Scheme of connections between the detection system and the amplification system, **b** view of the real system with the aluminum case

## 2.2 The preamplifier-amplifier pulses system

The charge sensitive preamplifier present in the integrated circuit A203 [5] collects the electrons accumulated in the anode of the detector after an ionizing event, and converts each discharge in a voltage pulse with cusp shape through a capacitive

circuit. The shaping stage of the A203 converts the cusp pulse in a pulse with Gaussian profile in order to reduce the harmonic content of the signal, allowing for an efficient propagation of the pulse through coaxial cables and prevent interference between consecutive pulses. The preamplifier also has other functions, among them to provide high input impedance for the detection system and low output impedance for driving coaxial cables and subsequent amplification stages.

In order to have suitable voltage levels for the pulse height analysis system, we use the linear amplifier A206, which amplifies by a factor of 10 the pulses obtained with the shaping amplifier stage. Integrated circuits A203 and A206 were connected in cascade in the printed circuit board PC-236, also supplied by Amptek [5]. The integrated A206 includes a lower level discriminator stage (LLD), which generates a logical pulse of 5  $\mu\text{s}$  width when the amplitude of a pulse in its input terminal exceeds a threshold voltage  $V_T$ , which can be adjusted by the user. This last module was not used in our implementation.

To prevent electromagnetic interference coming from external sources, the whole system A203-A206 was enclosed inside an aluminum box with walls of 2 mm thickness. The aluminum is one of the metals with best screening properties against electromagnetic interference of far field [6]. The scheme of the connections between the detector and the amplification system is presented in Fig. 1a, and a view of the real system is presented in Fig. 1b.

### 3 Results and discussion

#### 3.1 Irradiation of the detector with a $^{57}\text{Co}$ (Rh) Mössbauer source

We placed a Mössbauer source of  $^{57}\text{Co}$  (Rh) in front of the detection system, as shown in Fig. 2a. The output signal of the linear amplifier A206 was observed with a digital storage oscilloscope Tektronix TDS 3052B-500 MHz. A series of pulses captured and stored by the oscilloscope is presented in Fig. 2b. Four kinds of pulses were clearly identified in this signal, namely: pulses with amplitude close to 0.4 V correspond to X-rays of 6.3 keV coming from the deexcitation of  $^{57}\text{Fe}$  atoms after the electronic capture of  $^{57}\text{Co}$ ; pulses with amplitude close to 1.4 V correspond to gamma rays of 14.4 keV, coming from the deexcitation of the  $^{57}\text{Fe}$  from the first nuclear excited state with spin  $S = 3/2$  to the ground nuclear state with spin  $S = 1/2$ ; pulses with amplitude close to 2.0 V correspond to X-rays of 20.5 keV due to the deexcitation of the Rhodium atoms after their excitation by gamma rays of 122 keV and 136 keV, coming from decaying of the  $^{57}\text{Fe}$  from the nuclear excited state with spin  $S = 5/2$  to the nuclear state with spin  $S = 3/2$  and  $S = 1/2$ , respectively. The pulses with amplitude close to 0.2 V correspond to escape pulses of 1.8 keV, coming from electronic transitions in the Kr atoms after excitation by 14.4 keV gamma rays. Escape peaks have been reported in the pulses height spectra of Kr filled detectors irradiated by  $^{57}\text{Co}$  sources [7].

The ratio between the energy of the photons and the amplitude of the pulses is not constant because the detection efficiency of the proportional counter LND-45431 is a nonlinear function of the energy of the incident radiation [4], being its value close to 90 % for photons of 6 keV and 14.5 keV, lower than 20 % for photons with energies below 2 keV and lower than 65 % for photons with energies above 20 keV.

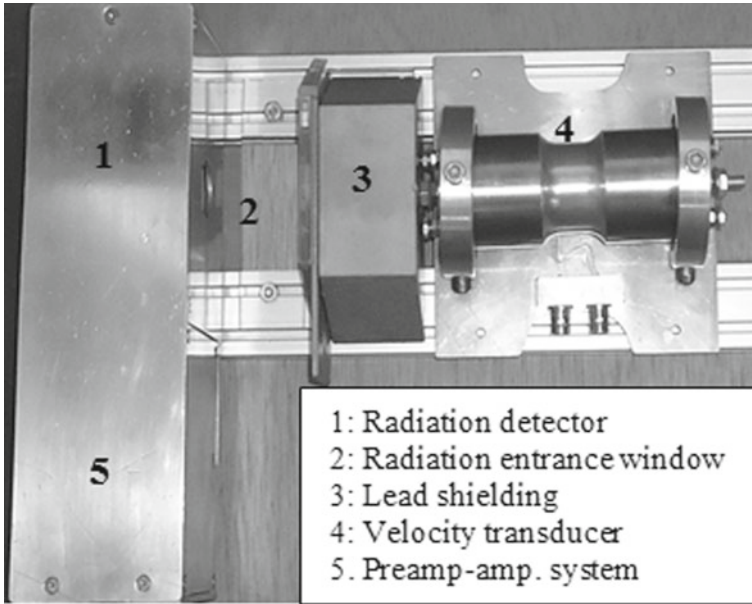

(a)

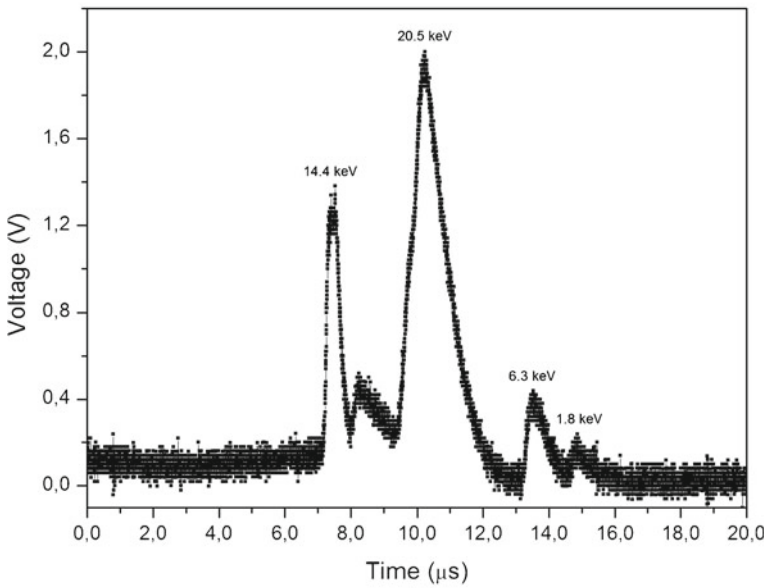

(b)

**Fig. 2** a Experimental component mounting, b voltage signal at the output of the linear amplifier, registered by a digital storage oscilloscope

The  $^{57}\text{Co}$  (Rh) source is threaded to the oscillation axis of a Doppler velocity modulator for Mössbauer effect, and can move within a lead shield to prevent user exposure to ionizing radiation it emits. The Doppler modulator was kept at rest

during the experiment and the distance between the source and the detector window was put at 6 cm to prevent the saturation of the preamplifier by high counting rates.

### 3.2 Pulse height analysis and Mössbauer spectra acquisition

A pulse height spectrum of the pulses obtained with the amplification system is presented in Fig. 3a. The pulse analysis system is integrated to the Multichannel Analyzer (MCA) developed by us in a previous work [8, 9]. In the spectrum is possible to observe the three kinds of pulses described before, with exception of the escape peak, because this does not overcome the noise gap voltage of 0.25 V selected in the circuit of our pulse height analyzer. The memory position where each pulse is counted, which is termed channel, is proportional to the amplitude of the pulse measured by the pulse height analyzer. Some nonlinearities may occur during the measurement of the pulse height, due to nonlinear elements used in the pulse height analysis circuit, among them diodes, in which the dynamic resistance decreases with the amplitude of the signal. These deviations from linearity generate some distortion of the positions of the peaks in the pulse height spectrum with respect to the original amplitudes of the pulses observed in Fig. 2b. However, these effects do not play an important role in Mössbauer spectroscopy because the main condition for making a satisfactory selection of the energy window is to have a well resolved Mössbauer peak in the pulse height spectrum, from which the nuclear resonant events can be determined and counted univocally.

From a graphic interface developed in the software LabVIEW [10], the user can select the 14.4 keV peak by dragging a system of bars labeled LL (Lower Level) and UL (Upper Level), located in the plot where the pulse spectrum is presented. Before acquiring a Mössbauer spectrum, the user sends from the computer to the MCA the values in channels indicated by the bars, which are placed at the ends of the 14.4 keV peak approximately, both values are converted to respective voltage levels by the Single Channel Analyzer (SCA) of the spectrometer in order to fix the limits of pulse discriminator, the details of the SCA operation are described in [8].

After selecting the Mössbauer peak in the pulse height spectrum, a standard absorber of  $\alpha$ -Fe with 28  $\mu\text{m}$  thickness was placed between the source and the detector and the velocity transducer was put in motion, the Mössbauer spectrum obtained is presented in Fig. 3b. The absorption percentage obtained for  $9 \times 10^5$  counts was close to 14 %, which is a satisfactory value for this sample.

Similar results can be obtained with commercial systems, such as the preamplifier-amplifier system PEA-6A developed by Wissel GmbH [11] and the preamplifier and amplifier systems 142PC and 575A, respectively, developed by ORTEC® [12]. However the system A203-A206 offers some advantages, such as no need to use bipolar voltage sources to supply power to the integrated circuits, only one voltage source with output between 10 V and 18 V is required; possibility of unipolar and bipolar outputs; the power consumption of the A203-A206 system is lower than 3 mA when operated at 15 V, being this current lower than several tens of mA required by commercial systems; the fall time of the pulses at the output of the preamplifier is 30  $\mu\text{s}$ , being this time lower than the time of 100  $\mu\text{s}$  characteristic of the commercial systems. This dynamic characteristic allows for an efficient counting of events, reducing the dead time of the counting system. Another important advantage of the linear amplifier A206 is the inclusion of a lower level discriminator (LLD) with

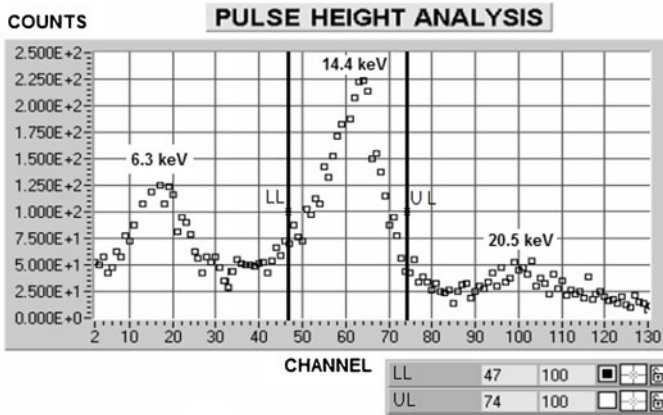

(a)

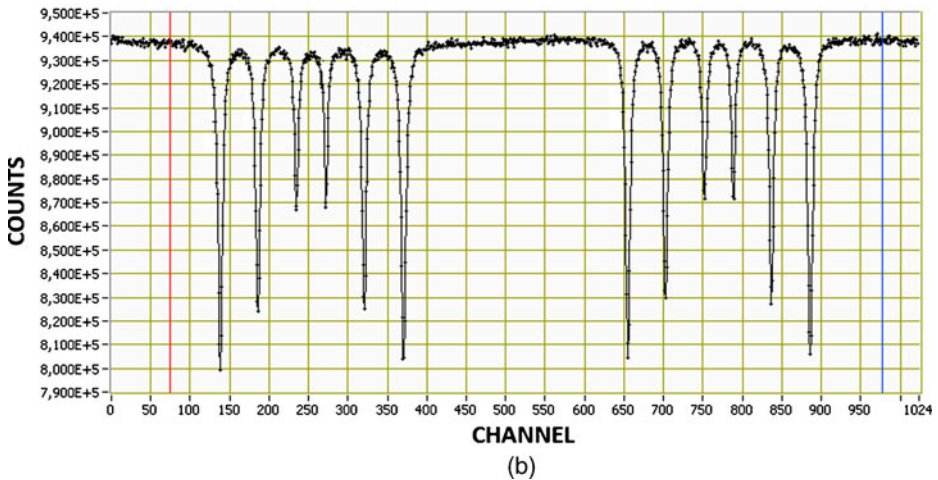

(b)

**Fig. 3** **a** Pulse height spectrum of a  $^{57}\text{Co}$  (Rh) source, **b** Mössbauer spectrum of a  $\alpha\text{-Fe}$  absorber obtained with the implemented system

logical pulses at the output, which can be used as a high pass energy filter in the Single Channel Analyzer of the spectrometer.

#### 4 Conclusions

From commercial integrated circuits, we have implemented a system for conditioning the electrical pulses produced by gaseous radiation detectors used in Mössbauer spectroscopy. The system allows to obtain a satisfactory signal-noise ratio, giving Gaussian profile pulses with amplitudes of the order of 1.4 V for the 14.4 keV Mössbauer gamma rays, which are suitable for the Pulse Height Analysis and Single Channel Analyzer modules of the Mössbauer spectrometer. A satisfactory absorption percentage, close to 14 %, was obtained for a natural iron absorber

by selecting the 14.4 keV peak in the pulse height spectrum. The system has a modular architecture, a simple implementation, easy tracking of the signals and a cost accessible for users of Mössbauer laboratories interested to develop their own instrumentation.

## References

1. Knoll, J.F.: Radiation Detection Measurement. Wiley, New York (1979)
2. Fabris, L., Madden, N.W., Yaver, H.: A fast, compact solution for low noise charge preamplifiers. Nucl. Instrum. Methods Phys. Res., Sect. A **424**, 545–551 (1999)
3. Bertuccio, G., Caccia, S.: Progress in ultra-low-noise ASICs for radiation detectors. Nucl. Instrum. Methods Phys. Res., Sect. A **579**, 243–246 (2007)
4. LND, INC.: 45431 beryllium side window proportional counter. <http://www.lndinc.com/products/pdf/41/> (2012). Accessed 12 May 2012
5. AMPTEK INC.: Charge sensitive preamplifier/shaping amplifier A203. <http://www.amptek.com/products.html> (2012). Accessed 12 Jul 2012
6. Pérez, M.A., Álvarez, J.C., Campo, J.C., Ferrero, F.J., Grillo G.J.: Instrumentación Electrónica, p. 789. Thomson, Madrid (2004)
7. SEE Co: User manual for the model W202. <http://www.seeco.us/uploads/W202UserGuide.pdf> (2011). Accessed 20 Jun 2011
8. Velásquez, A.A., Gancedo, J.R., Trujillo, J.M., Morales, A.L., Tobón, J.E., Reyes L.: Design and construction of an autonomous low-cost pulse height analyzer and a single channel analyzer for Mössbauer spectroscopy. AIP Conf. Proc. **765**, 389–384 (2005)
9. Velásquez, A.A., Trujillo, J.M., Morales, A.L., Tobón, J.E., Reyes, L., Gancedo, J.R.: Design and construction of an autonomous control system for Mössbauer spectrometry. Hyperfine Interact. **161**, 139–145 (2005)
10. National Instruments Corporation: LabVIEW user manual. <http://www.ebookbrowse.com/labview-user-manual-pdf-d318609414> (2013). Accessed 10 Jan 2013
11. Wissel GmbH: PEA-6A preamplifier+main amplifier. [http://www.wissel-instruments.de/index.php?option=com\\_content&task=view&id=44&Itemid=67](http://www.wissel-instruments.de/index.php?option=com_content&task=view&id=44&Itemid=67) (2013). Accessed 10 Jan 2013
12. ORTEC: 142PC preamplifier. <http://www-esd.fnal.gov/esd/catalog/main/egg/142pc.pdf> (2013). Accessed 10 Jan 2013