

Internal Differential Boomerangs: Practical Analysis of the Round-Reduced Keccak- f Permutation

Jérémy Jean^(✉) and Ivica Nikolić

Nanyang Technological University, Singapore, Singapore
{JJean, INikolic}@ntu.edu.sg

Abstract. We introduce internal differential boomerang distinguisher as a combination of internal differentials and classical boomerang distinguishers. The new boomerangs can be successful against cryptographic primitives having high-probability round-reduced internal differential characteristics. The internal differential technique, which follow the evolution of differences between *parts of* the state, is particularly meaningful for highly symmetric functions like the inner permutation Keccak- f of the hash functions defined in the future SHA-3 standard. We find internal differential and standard characteristics for three to four rounds of Keccak- f , and with the use of the new technique, enhanced with a strong message modification, show practical distinguishers for this permutation. Namely, we need 2^{12} queries to distinguish 7 rounds of the permutation starting from the first round, and approximately 2^{18} queries to distinguish 8 rounds starting from the fourth round. Due to the exceptionally low complexities, all of our results have been completely verified with a computer implementation of the analysis.

Keywords: SHA-3 · Keccak · Internal differential · Boomerang · Practical-complexity distinguisher

1 Introduction

The family of sponge functions Keccak [3] was one of the proposals for the hash function competition organized by NIST [29]. In 2012, Keccak was announced as the winner, and some hash functions from this family will officially become part of the SHA-3 standard [30], to complement the SHA-2 hash standard. As such, Keccak is among the most significant cryptographic primitives to date; its security is therefore of crucial importance.

In the past several years, Keccak has received significant amount of attention from the cryptographic community, both during the competition and after being announced as the winning algorithm. Analyses of round-reduced versions have

The authors are supported by the Singapore National Research Foundation Fellowship 2012 (NRF-NRFF2012-06). A long version of this paper is available in [18].

been proposed for the hash function, for the underlying permutation, and for various secret-key schemes based on this permutation. So far, the best attacks on the hash function in the standard model reach five rounds [14, 15], while in the keyed model reach up to nine rounds [16]. For the underlying permutation, the best analysis in terms of complexity reaches six rounds and requires 2^{11} queries [22], while in terms of number of rounds, the best is eight and requires 2^{491} queries [17].

In this paper, we present distinguishers for round-reduced versions of the permutation *Keccak-f* used in *Keccak* based on a new analysis technique called *internal differential boomerang distinguishers*. We stress that we propose distinguishers on the round-reduced permutation: the paper does not target a keyed mode using it, while the technique may encourage follow-up works. From a high-level perspective, this technique resembles classical boomerangs, but in one part of the boomerang it uses internal differentials, which consider differences between *part of* a state, rather than a difference *between* two states. As a result, our boomerang produces *pairs* of state values that have specific input internal and output differences, while classical boomerangs produce *quartets* of inputs.

More precisely, on the one hand, the classical boomerang starts with an input pair that has a specific internal difference, and the corresponding outputs are computed. Then, a second output pair is produced by XORing a specific difference to both output values, and finally, these values are inverted to a second input pair, and it is checked if this pair has the same specific input difference. On the other hand, the internal differential boomerang distinguisher framework depicted in this paper is slightly different than this classical boomerang scenario since it considers *internal* differences, which ultimately produces pairs of inputs rather than quartets. Specifically, an input with particular *internal* difference generates an output to which we apply a specific output difference. The second output is then inverted to a second input, and one checks whether it has the given input *internal* difference.

For both these kinds of boomerangs, the time complexity required to generate either a right quartet or a right pair depends on the probability of the differentials (internal differentials or regular differentials) used in the two parts of the primitive. Furthermore, in internal differential boomerangs, the part of the primitive covered by the internal differential is passed twice, whereas the part covered by the standard differential only once (in classical boomerang, both of the parts are passed twice). Thus, our technique outperforms the classical boomerangs when high-probability internal differentials exist for several rounds of the primitive. We further give an evaluation of the time complexity required to generate right quartets and pairs for both types of boomerangs, and discuss the use of the message modification technique to greatly reduce this complexity when we have the ability to choose bits of intermediate state values.

Interestingly, Dinur et al. [14] collision attacks on *Keccak* can be seen as an instance of our boomerangs: as they perform only forward queries, their attacks are in fact amplified version of our boomerangs. Thus, the boomerangs presented here can be seen as a generalization of [14].

We distinguish the round-reduced *Keccak-f* permutation by producing boomerang pairs. First, we find internal differential and standard differential characteristics that are used in the boomerangs. The characteristics span on three to four rounds and, as in some rounds the differences are truncated, have very high probabilities. We combine the characteristics according to the internal differential boomerang, and with the use of an enhanced message modification (which allows to pass deterministically the two low probability rounds in the middle of the boomerang), obtain boomerang pairs with low and practical complexity. We also provide a rigorous bound on the query complexity of producing such boomerang pairs in the case of a random permutation. As this complexity is much higher than what we need for round-reduced *Keccak-f*, we claim distinguishers.

Our internal characteristics depend on the round constants, thus we give distinguishers on the round-reduced *Keccak-f* permutation for two different cases: when the permutation starts¹ at round 0, and when it starts at round 3. In the first case, we can distinguish the permutation reduced to 6 rounds with 2^5 queries, and 7 rounds with 2^{13} queries. In the second case, we can distinguish 7 rounds with $2^{10.3}$ queries, and 8 rounds with $2^{18.3}$ queries.

We emphasize that the whole analysis, due to its exceptionally low complexity, has been implemented and successfully verified. We refer the reader to [18] for the outputs produced by our computer experiments. We also stress that our results do not threaten the security of the full-round *Keccak-f* permutation. A summary of previous analysis of *Keccak*, along with our new results, are given in Tables 1 and 2.

Application of the Internal Differential Boomerangs. The impact of this kind of boomerangs depends on the analyzed framework. When the subject of analysis is a block cipher, then the impact of the internal differential boomerangs is similar to that of the classical boomerangs, i.e. they immediately lead to distinguishers and possibly can be extended to key recovery attacks. On the other hand, in the framework of hash/compression functions and permutations, their significance depends on the quality of the internal differential and standard differential characteristics used to produce the boomerang pairs. For instance, if the input internal difference complies to the conditions of the input to the hash/compression function and the output difference has a low hamming weight, then an internal differential boomerang pair may lead to near collisions.

The internal differential boomerangs presented further in this paper only apply to the round-reduced *Keccak-f* permutation, but not to *Keccak*. This is due to the message modification used in the middle states, which results in inputs that do not comply to the inputs conditions to the sponge construction of *Keccak* where the values in the capacity part cannot be controlled. Similarly, it prevents applying the distinguishers to other keyed constructions, such

¹ Note that while the draft FIPS 202 [30] defines the r -round-reduced versions of *Keccak-f* as the last r rounds of *Keccak-f*, this paper allows the reduced permutation to start at any round number.

Table 1. Summary of attacks on Keccak.

Rounds	Complexity	Type	Technique	Reference
2	2^{33}	Collision	Differential	[31]
2	2^{33}	Preimage	Differential	[31]
3	2^{25}	Near-Collision	Differential	[31]
4	2^{221}	Preimage	Rotational	[26]
4	2^{25}	Distinguisher	Differential	[31]
4	practical	Collision	Differential	[15]
4	practical	Collision	Differential	[21]
4	2^{506}	Preimage	Rotational	[26]
5	2^{115}	Collision	Int. differential	[14]
5	2^{35}	Key recovery (MAC)	Cube attack	[16]
5	practical	Near-Collision	Differential	[15]
6	2^{52}	Distinguisher	Differential	[12]
6	2^{36}	Key recovery (Stream)	Cube attack	[16]
8	2^{129}	MAC forgery	Cube attack	[16]
9	2^{256}	Keystream prediction	Cube attack	[16]

Table 2. Distinguishers of reduced-round versions of Keccak- f .

Rounds	Complexity	Type	Technique	Reference
5	2^8	Distinguisher	Rebound	[17]
6	2^5	Distinguisher	Internal Diff. Boomerang	Section 4
6	2^{10}	Distinguisher	Zero-sum	[1,9]
6	2^{11}	Distinguisher	Self-symmetry	[22]
6	2^{32}	Distinguisher	Rebound	[17]
6.5	unknown	Distinguisher	Cube tester	[16]
7	2^{10}	Distinguisher^a	Internal Diff. Boomerang	Section 4
7	2^{13}	Distinguisher	Internal Diff. Boomerang	Section 4
7	2^{15}	Distinguisher	Zero-sum	[1,9]
7	2^{142}	Distinguisher	Rebound	[17]
8	2^{18}	Distinguisher^a	Internal Diff. Boomerang	Section 4
8	2^{18}	Distinguisher	Zero-sum	[1,9]
8	2^{491}	Distinguisher	Rebound	[17]
24	2^{1590}	Distinguisher	Zero-sum	[10]

^a: Start from round 3.

as Keyak [5] and Ketje [4]. Therefore, our internal differential boomerangs only allow to distinguish round-reduced Keccak- f from a random permutation. However, their impact relate to Keccak since it adopts the hermetic sponge strategy

as a design philosophy [2]. In its original formulation, this consists of using the sponge construction (providing security against generic attacks) and calling a permutation that should not have any properties (called structural distinguishers) besides having a compact representation. Our results disprove this requirement for the round-reduced *Keccak-f* by showing a non-random behavior.

2 Description of *Keccak-f*

In this section, we give a partial description of the hash functions that will be defined in the future *SHA-3* standard [30]. In particular, since the results in this paper only deal with the inner permutation (further denoted by *Keccak-f*), we do not recall the details of the sponge construction. For a complete description of this family of functions, we refer the interested reader to [3,30].

The *Keccak-f* permutation works on a state of $b = 25 \times 2^l$ bits, where $b \in \{25, 50, 100, 200, 400, 800, 1600\}$, and has $n_r = 12 + 2l$ rounds. We count the rounds starting from zero. The results in this paper consider round-reduced versions of *Keccak-f*[1600], where the full permutation has $n_r = 24$ rounds. As introduced in [30], we define by *Keccak-p* a round-reduced version of the *Keccak-f* permutation, where its $n \geq n_r$ rounds are the n last ones of *Keccak-f*. In this paper, we leverage the restriction on the starting round number and further introduce the notation *Keccak-p_{i,n}* to consider the n consecutive rounds of *Keccak-f*[1600] starting at round i ; that is, rounds $i, \dots, i + n - 1$. Using this notation, *Keccak-f*[1600] would be *Keccak-p_{0,24}*.

Each round of *Keccak-f*[b] is composed of five steps: the first three (θ , π and ρ , in this order) are linear and further denoted together by $\lambda = \pi \circ \rho \circ \theta$, the fourth step is non-linear and denoted by χ , and the last step ι adds round-dependent constants $RC[i]$, $0 \leq i < n_r$, to break symmetries. Each step applies to different parts of the state, which is seen as a three-dimensional array of bits of dimension $5 \times 5 \times b$. A bit $S[x, y, z]$ in a state S is addressed by its coordinates (x, y, z) , $0 \leq (x, y) < 5$ and $0 \leq z < b$. Furthermore, for fixed x, y and z , $S[x, y, \bullet]$ refers to a *lane* of b bits, and $S[\bullet, \bullet, z]$ to a *slice* of 25 bits.

We now discuss the details of each of the five steps on a given input state S :

The θ step operates on the slices of the state by performing the following operation at each coordinate (x, y, z) :

$$S[x, y, z] \leftarrow S[x, y, z] \oplus \left(\bigoplus_{y'=0}^4 a[x-1, y', z] \right) \oplus \left(\bigoplus_{y'=0}^4 a[x+1, y', z-1] \right).$$

This linear step brings diffusion to the state. For instance, it expands a single bit difference to 11 bits, while the inverse step θ^{-1} expands it to about $b/2$ bits.

The ρ step rotates the bits inside each lane. The rotation constants are independent of the round numbers, and they are different for each of the 25 lanes (refer to [3] for the actual values).

The π step operates on each slice independently by permuting the 25 bits. Namely, at each coordinate (x, y, z) , it applies:

$$S[x', y', z] \leftarrow S[x, y, z], \quad \text{where:} \quad \begin{pmatrix} x' \\ y' \end{pmatrix} = \begin{pmatrix} 0 & 1 \\ 2 & 3 \end{pmatrix} \begin{pmatrix} x \\ y \end{pmatrix}.$$

This step mixes the lanes and thus brings an additional diffusion to the state.

The χ step is the only non-linear operation in a round and it applies the same 5-bit S-Box to each 5-bit row $S[\bullet, y, z]$ of the internal state. In total, $b/5$ independent S-Boxes are applied, that is 320 in the case of Keccak- f [1600]. The S-Box has maximal differential probability 2^{-2} .

The ι step XORs the b -bit round-dependent constant $RC[i]$ at round i to the lane $S[0, 0, \bullet]$, $0 \leq i < n_r$.

3 The Internal Differential Boomerang Distinguisher

In this section, we introduce a new distinguisher called the *internal differential boomerang distinguisher*. As it combines internal differentials and the boomerang attack, we first give a brief overview of these two strategies, and then present the new technique.

3.1 The Internal Differential Attack

In the internal differential attack [32], the adversary observes the propagation of *the difference between the two halves of the same state* through the rounds of the cryptographic function/permutation. Similar to the case of classical differential analysis, the goal of the adversary is to show that the propagation of some particular internal difference happens with an unusually high probability.

Let F be a permutation, and the n -bit state S is split into two halves S^H and S^L . With this notation, it follows that $|S^H| = |S^L|$ and $S = S^H \parallel S^L$. The internal difference $\delta(S)$ of the state S is computed as the XOR of its two halves, i.e. $\delta(S) = S^H \oplus S^L$. Then, an internal differential for F is a pair of internal differences (Δ, ∇) , and its probability is defined as:

$$\Pr_S \left(\delta(F(S)) = \nabla \mid \delta(S) = \Delta \right).$$

In other words, this is the probability that a randomly chosen input state S with an internal difference Δ , after the application of F , will result in an output state with internal difference ∇ . Similarly to the standard differential attacks, we can define an internal differential characteristic as the propagation of the internal differences through the rounds of the permutation. Obviously, to each such internal differential characteristic, we can associate a probability that this propagation holds as expected.

3.2 The Boomerang Attack

In classical boomerang attacks [34]², the permutation F is seen as a composition of two permutations $F = g \circ f$, where each of them covers some rounds at the beginning and at the end of F . Even though a high-probability differential might not exist for F , if high-probability differentials do exist for the two permutations f and g , then one can attack F with the boomerang technique.

Let $\Delta \rightarrow \Delta^*$ be a differential for f that holds with a probability p and $\nabla \rightarrow \nabla^*$ be a differential for g that holds with a probability q . According to Fig. 1, the adversary starts with a pair of inputs $(P_1, P_2) = (P_1, P_1 \oplus \Delta)$ and, by applying F , produces a pair of corresponding outputs $(C_1, C_2) = (F(P_1), F(P_2))$. Then, the adversary produces a new pair of outputs $(C_3, C_4) = (C_1 \oplus \nabla^*, C_2 \oplus \nabla^*)$. For this pair, the adversary obtains the corresponding pair of inputs $(P_3, P_4) = (F^{-1}(C_3), F^{-1}(C_4))$. The main observation of the boomerang technique is that the difference $P_3 \oplus P_4$ would be Δ with a probability of at least p^2q^2 because:

1. The difference $f(P_1) \oplus f(P_2)$ is Δ^* with probability p .
2. The two differences $g^{-1}(C_1) \oplus g^{-1}(C_3)$ and $g^{-1}(C_2) \oplus g^{-1}(C_4)$ are both ∇ with probability q^2 .
3. When 1. and 2. hold, then the difference $g^{-1}(C_3) \oplus g^{-1}(C_4)$ is Δ^* (with probability pq^2), and therefore $f^{-1}(C_3) \oplus f^{-1}(C_4)$ is Δ with probability p^2q^2 .

The quartet of states (P_1, P_2, P_3, P_4) fulfilling the conditions $P_1 \oplus P_2 = P_3 \oplus P_4 = \Delta$ and $F(P_1) \oplus F(P_3) = F(P_2) \oplus F(P_4)$ is called a *boomerang quartet*. As shown above, the quartet can be found in time equivalent to $(pq)^{-2}$ queries to the permutations. On the other hand, finding the boomerang quartet in the case of a random permutation requires about 2^n queries. Consequently, the boomerang approach yields a distinguisher for F as soon as the adversary can find the two differentials for f and g such that $(pq)^{-2} < 2^{-n}$, that is $pq > 2^{-n/2}$.

It has been shown in [7, 8] that when F is a public permutation, a block cipher in the chosen-key attack framework, or a compression function, then the complexity of producing the boomerang quartet can be reduced with the use of the message modification technique. That is, the adversary can choose particular state words to ensure that some probabilistic differential transitions hold with probability one. Consequently, some rounds can be passed deterministically, so that their probabilities do not contribute towards the total probability $(pq)^2$. The number of such free rounds depends on how efficiently the message modification can be applied. In general, the modification is used in the rounds around the boomerang switch, i.e. the last few rounds of f and the first few rounds of g .

3.3 The Internal Differential Boomerangs

In this section, we show that the internal differential attack can be used in the boomerang setting: we call this combined analysis *the internal differential*

² The boomerang attack is closely related to higher-order differential techniques [20, 23].

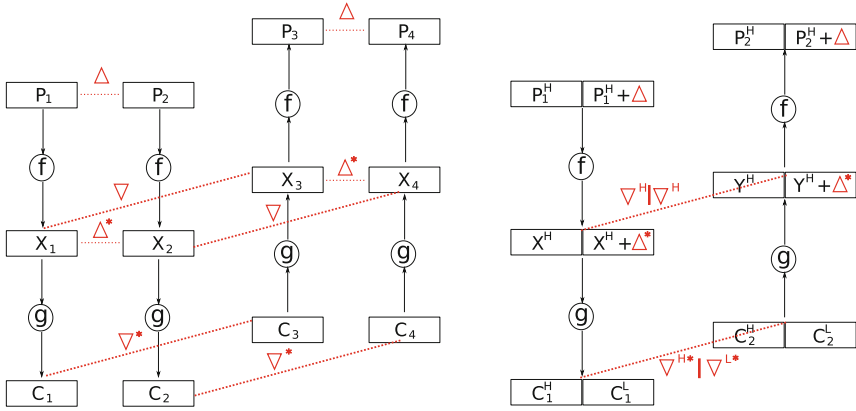

Fig. 1. The classical boomerangs (left). The internal differential boomerangs (right).

boomerangs. Although this new type of analysis shares similarity with the classical boomerangs based on standard differentials, we emphasize that there are a few differences between them. The first difference is in the number of differentials required to achieve the boomerang: the classical boomerang uses four differentials, whereas the internal differential boomerang works with only three. The second difference is in the type of differentials: the classical boomerang can use (almost) any two differentials for f and g , while for the internal differential boomerang, one of the differentials must have a special type.

Let F be a permutation that (similarly to the classical boomerang) is seen as a composition $F = g \circ f$. Let (Δ, Δ^*) be an *internal differential* for f that holds with probability p , and (∇, ∇^*) be a *standard differential* for g that holds with probability q , where the input difference ∇ has an internal difference of zero, i.e. $\delta(\nabla) = 0$. Then, the internal differential boomerangs can be described as:

1. Fix a random input P_1 with an internal difference Δ , i.e. $\delta(P_1) = \Delta$.
2. Produce the corresponding output $C_1 = F(P_1)$.
3. Produce another output C_2 such that $C_2 = C_1 \oplus \nabla^*$.
4. Produce the corresponding input $P_2 = F^{-1}(C_2)$.
5. Check if $\delta(P_2) = \Delta$. If it holds, output (P_1, P_2) , otherwise go to 1.

The probability that the condition at step 5 holds is at least p^2q . This is based on a reasoning illustrated in Fig. 1. Let $\nabla = \nabla^H \parallel \nabla^H$ and $\nabla^* = \nabla^{H*} \parallel \nabla^{L*}$ be the input and the output differences of the standard differential used in the function g . For a random input $P_1 = P_1^H \parallel (P_1^H \oplus \Delta)$, the output $X = f(P_1)$ will be $X^H \parallel (X^H \oplus \Delta^*)$ with probability p . Furthermore, for a pair of outputs (C_1, C_2) such that $C_1 \oplus C_2 = \nabla^* = \nabla^{H*} \parallel \nabla^{L*}$, after the inversion of g , the output pair (X, Y) will satisfy $X \oplus Y = \nabla = \nabla^H \parallel \nabla^H$ with probability q . Then,

$$Y = X \oplus \nabla = \left[X^H \parallel (X^H \oplus \Delta^*) \right] \oplus \left[\nabla^H \parallel \nabla^H \right] = Y^H \parallel (Y^H \oplus \Delta^*),$$

where $Y^H = X^H \oplus \nabla^H$. Therefore, the internal difference in Y is Δ^* , and after the inversion of f , it will become Δ with probability p . As a result, this algorithm outputs a pair of inputs with probability p^2q . We call such a pair an internal differential boomerang pair.

For a random n -bit permutation F , the pair can be found in around $2^{n/2}$ queries³ to F . Therefore, the internal differential boomerang yields a distinguisher if $p^2q > 2^{-n/2}$. Recall that the same condition for the classical boomerangs is $pq > 2^{-n/2}$. Consequently, it is beneficial to use the internal differential boomerang technique over the classical boomerang strategy only if the internal differential for f has a much higher probability than a differential for f .

Given a public permutation (or a compression function) $F = g \circ f$, we can start the internal differential boomerang in any round of f (but not in g), and from there produce the pair of inputs and the pair of outputs. It is usually beneficial to start at the end of f and, with the use of the message modification technique, to pass a few rounds around the boomerang switch for free (deterministically). Then, the formula for the probability of the boomerang becomes $p_*^2q_*$, where p_* and q_* are the differential probabilities of the non-linear parts of f and g respectively, that are passed probabilistically.

Dinur et al. Collision Attack. In [14], Dinur et al. present a collision attack on reduced variants of Keccak hash function by selecting message blocks in a small subspace⁴ such that a high-probability characteristic might map them to a small subspace after a certain number of rounds of Keccak- f . More precisely, they find round-reduced internal characteristics and they extend them for an additional 1.5 round. They call this extension *bounding the size of the output subset* and note that this is possible because the differences are quite sparse and the χ step has a slow diffusion.

We note that Dinur et al. collision attack is in fact based on the internal differential boomerangs presented in this paper. Their internal differential characteristics corresponds to the internal differential part of the boomerang, whereas the aforementioned extension is the standard differential part of the boomerang. Furthermore, Dinur et al. start the attack from the two inputs with specific internal differences and then check if the difference of the two outputs is as expected. This is precisely the variant of the boomerang attack called amplified boomerang [19], where the attacker only makes forward queries. Thus, Dinur et al.'s collision attack succeeds as after the amplification in the middle, the remaining 1.5 rounds are passed according to any standard differential that at the output has no active bits among those that comprise the hash value.

Truncated Differences. We further analyze the case when the input internal difference Δ and the output standard difference ∇^* of the boomerang are not fully determined, but are truncated. Namely, only some bits of these differences

³ In a random permutation, the boomerang will return P_2 with internal difference Δ with a probability $2^{-n/2}$.

⁴ A related subspace problem has been discussed in [24].

are determined, whereas the remaining bits can have any value. The lemma given below defines a lower bound on the complexity of finding such boomerang pair in the case of a random permutation. Note, in the lemma, we assume the output difference to be XOR difference, that is, the output difference is produced as an XOR of the two outputs.

Lemma 1. *For a random n -bit permutation π , the query complexity Q of producing an internal differential boomerang pair, with truncated input internal difference Δ determined in n_I bits and truncated XOR output difference ∇^* determined in n_O bits, satisfies:*

$$Q \geq \min(2^{n_I-2}, 2^{\frac{n_O}{2}-\frac{3}{2}}).$$

Due to space constraints, we refer the interested reader to [18] for the proof of this lemma.

4 Distinguishers for the Round-Reduced Keccak- f Permutation

In this section, we present internal differential boomerang distinguishers on the round-reduced permutation Keccak- f [1600], further denoted Keccak- $p_{i,n}$, where the starting round i and the number of rounds n is specified in the text for each case. In comparison to [30] where all the reduced variants simply called Keccak- p start at the first round, we allow the permutation to start at any number of round.

To describe our results, we first define the two differentials used in the boomerang: the internal differential used in the first rounds, and the standard differential used in the last rounds. Next, we show that a message modification can help to deterministically pass the two rounds that surround the boomerang switch. Finally, we present the actual distinguishers.

4.1 Internal Differential Characteristics

The 1600-bit state S of Keccak is composed of 25 lanes of 64 bits. The internal difference $\delta(S)$ of the state is defined as the XOR difference between the higher 32 bits and the lower 32 bits, for each lane. Hence, the internal difference is composed of 25 words of 32 bits, and can be seen as an 800-bit vector.

Let us scrutinize the behavior of the five round steps in regard to internal differences. The linear step θ may introduce an increase in the hamming weight of the internal difference, by a factor up to 11. The two steps ρ and π only permute the bits in the internal differences, but maintain their hamming weight. The non-linear step χ may increase the hamming weight of the internal difference. For instance, one-bit difference at the input (resp. output) of the S-box, may become a difference in more than 1 bit at the output (resp. input) of the S-box. However, a fixed 1-bit input difference can affect only up to three bits in the

we can fully compute the internal difference at the input of the characteristic, so that each of the 800 bits are fully determined. Therefore, the whole 3-round internal characteristic has 34 active S-Boxes (probability 2^{-68}), and in the first two rounds has only a single active S-Box (probability 2^{-2}).

The Internal Differential \mathcal{ID}_4 . We can construct a longer characteristic by going backwards one additional round. However, in this round the hamming weight of the internal difference at the input of χ^{-1} would be high (in the above \mathcal{I}_3 , the weight is 429). To avoid significant reduction of probability, we switch to truncated internal differences. That is, instead of trying to define completely the output difference of this χ^{-1} (that would be obtained with an extremely low probability), we specify the difference only in n_I bits out of 800 bits. The internal difference in each of these n_I specific bits can be either 0 or 1, but the probability of this event must be one. As a result, the probability of the first round of the characteristic would be one.

Once the truncated difference is fixed in n_I bits at the output of χ^{-1} , the remaining three *linear* steps of the round will keep the truncated property: π^{-1} and ρ^{-1} will only permute and rotate the truncated difference and thus at the output of these two steps still it will be defined in n_I bits, while at the output of θ^{-1} the internal difference will belong to a subspace of dimension $800 - n_I$. We note that with a minor modification of Lemma 1, the obtained input internal difference can be used to compare the query complexity to the generic case⁵ Therefore, to simplify the presentation of the input internal difference, in the further analysis, we omit the three linear steps of the first round.

The number of bits n_I in which the truncated difference at the output of χ^{-1} is defined with probability one depends on the round constants RC_i . For instance, if we start with round 0, then there is no bits in which the truncated difference is determined, i.e. $n_I = 0$. Only if we start with round 3, the number n_I will be sufficiently large to claim later (according to Lemma 1) that the complexity of producing boomerang pairs for $\text{Keccak-p}_{3,n}$ is lower than the generic complexity, with $n \in \{7, 8\}$.

The resulting 4-round internal differential characteristic \mathcal{I}_4 , that starts at round 3, is defined as:

$$\begin{array}{ccccccc}
 \left[\begin{array}{c} ? \\ 64 \end{array} \right] & \xleftarrow{\chi^{-1}} & \left[\begin{array}{c} 398 \\ 800 \end{array} \right] & \xleftarrow{\zeta_3^{-1}} & \left[\begin{array}{c} 397 \\ 800 \end{array} \right] & \xleftarrow{\lambda^{-1}} & \left[\begin{array}{c} \mathbf{5} \\ 800 \end{array} \right] & \xleftarrow{\chi^{-1}} & \left[\begin{array}{c} \mathbf{5} \\ 800 \end{array} \right] & \xleftarrow{\zeta_4^{-1}} & \left[\begin{array}{c} 0 \\ 800 \end{array} \right] & \xrightarrow{\lambda, \chi} & \left[\begin{array}{c} 0 \\ 800 \end{array} \right] & \xrightarrow{\zeta_5} & \left[\begin{array}{c} 2 \\ 800 \end{array} \right] & \xrightarrow{\lambda} & \left[\begin{array}{c} 22 \\ 800 \end{array} \right] & \xrightarrow{\chi, \iota_2} & \left[\begin{array}{c} ? \\ 800 \end{array} \right] \\
 \longleftarrow & & \longleftarrow & & \longleftarrow & & \longleftarrow & & \longleftarrow & & \longleftarrow & & \longrightarrow & & \longrightarrow & & \longrightarrow & & \longrightarrow & & \longrightarrow \\
 \text{Round 3} & & & & \text{Round 4} & & & & \text{Round 5} & & & & & & \text{Round 6} & & & & & & &
 \end{array}$$

The characteristic has been built by fixing a zero internal difference at the input of round 5. The forward propagation is similar to \mathcal{I}_3 . Backwards, after the addition of the constant $RC[4]$, the weight of the internal difference is five. Hence, χ of round 4 has at most five active S-Boxes, that can be passed probabilistically and would result in a state with internal difference of weight five. Then, the linear

⁵ That is, we use the subspace to claim distinguisher for the permutation. This is in line with our initial intention to show that the round-reduced permutation exhibits non-random properties.

steps λ^{-1} in round 4 and the addition of $RC[3]$ in round 3 increase the weight of the internal difference to 398. *In the following χ^{-1} , we switch to truncated differences.* Although the input difference has a weight of 398 (possibly, all 320 S-Boxes are active), at the output of χ^{-1} , the internal difference is 0 in 55 specific bits, and 1 in 9 other bits. In other words, $n_I = 55 + 9 = 64$ bits of the internal difference are defined deterministically and thus, the probability to pass this χ^{-1} is one. Note, the truncated characteristic in the first round holds with probability one only when moving backwards through the round.

The probability of the truncated internal differential characteristic \mathcal{I}_4 can be evaluated as follows: in round 3 the probability is 1, in round 4 there are 5 active S-Boxes, thus the probability is 2^{-10} , in round 6 there are no active S-Boxes, while in round 7 there are 22 active S-Boxes (probability is 2^{-44}). Hence, when going backwards through the rounds, the probability of the whole 4-round characteristic is 2^{-54} . Furthermore, the probability of the first three rounds is 2^{-10} .

Recall that the boomerangs can use differentials instead of characteristics. As the probability of a differential may be higher than the probability of a single characteristic, the complexity of producing boomerang pairs may be reduced. Therefore, let us build a 4-round differential \mathcal{ID}_4 by using the same approach as for \mathcal{I}_4 . That is, for all of the characteristics that belong to \mathcal{ID}_4 , we start at round 5 with zero internal difference. In the forward direction, we move deterministically through round 5 and at the input of χ in round 6, we have 22 active S-Boxes (i.e. all the characteristics are equally defined in this part of the differential). In the backward direction, all the characteristics are the same up to the input of χ^{-1} of round 4, but the five active S-Boxes in each of the characteristics results in different outputs. Then, for each of the outputs, we move through λ^{-1} of round 4, ι_3 , χ^{-1} of round 3, and at the output of χ^{-1} , we check if the truncated difference is defined in the same 64 bits as \mathcal{I}_4 . Therefore, all the characteristics of the differential \mathcal{ID}_4 have the same input truncated difference, and the same difference at the input of χ in round 6 (the output of this χ is irrelevant as before). We found experimentally the probability of \mathcal{ID}_4 for the first three rounds to be $2^{-4.6}$. This has to be compared to 2^{-10} , which is the probability of the first three rounds of the characteristic \mathcal{I}_4 .

4.2 Standard Differential Characteristics

Along with internal differential characteristics, the boomerang technique described in this paper uses standard differential characteristics. Recall that due to the special requirement of our boomerang, the standard characteristic cannot be of any form since it is connected to the two internal characteristics. This constraints the input difference ∇ of the standard characteristics to be symmetric, i.e. $\nabla = \nabla^H \parallel \nabla^H$, or $\delta(\nabla) = \nabla^H \oplus \nabla^H = 0$. Note, the standard characteristic (unlike the internal characteristic) does not depend on the round number, hence further we omit ι_i from the description of the characteristic.

The standard characteristic that we use relies on the already-known concept of parity kernels, which allows to minimize the number of S-Boxes in two consecutive rounds of Keccak- f . This notion has been described in the submission

document [3], and has been used in cryptanalytic results [12, 22, 31]. The behavior is possible due to two observations: first, a state-difference may be invariant of the θ step if there is an even number of active bits in each of the 320 column of the internal state; and second, an active S-Box in χ (or in χ^{-1}) leaves unchanged a 1-bit difference with probability 2^{-2} .

The 4-round standard differential characteristic \mathcal{C}_4 that we use in the boomerangs is defined as:

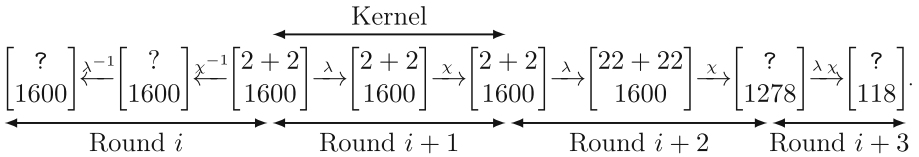

The notations used in the characteristic are the same as before. With “ $x+x$ ”, we emphasize that the states are comprised of $2x$ active bits, but the actual difference is symmetric, which implies that there are x active bits in each half of the state, with equal differences.

This differential characteristic has been constructed by selecting a symmetric difference of hamming weight four at the input of round $i + 1$ (note, this is the smallest possible weight of a symmetric parity kernel). In the backward direction, the step χ^{-1} has only 4 active S-Boxes, and results in a difference that is irrelevant as we further show in Sect. 4.3. In the forward direction, the selected 4-bit difference acts as a kernel and thus, after the λ step of round $i + 1$, results in a 4-bit difference. The same behavior of the following χ step is expected with probability 2^{-8} , so the input difference to round $i + 2$ still has a weight of four. The linear step in this round expands the difference to 44 active bits. Then, *we switch to truncated differences*. As a result, the difference in the following χ step is defined in 1278 bits, and after all the steps of round $i + 3$, the difference is still deterministically defined in 118 bits (78 zeros and 30 ones).

The differential characteristic \mathcal{C}_4 covers four full rounds of the permutation, and holds with probability 2^{-16} in the forward direction since there are a total of 8 active S-Boxes (four in each of the rounds i and $i + 1$).

We can define a 3-round differential characteristic \mathcal{C}_3 , which is basically the same as the first three rounds of \mathcal{C}_4 , but we start truncating from χ at round $i + 1$. That is, in \mathcal{C}_3 , we begin with 4-bit difference at round $i + 1$ and the backward round i is the same as \mathcal{C}_4 . However, the 4-bit input difference at χ of round $i + 1$ results in truncated output difference (with probability 1, instead of 2^{-8}), and after the steps λ and χ of round $i + 2$, the truncated difference can still be determined in 1278 bits. Therefore, the probability of \mathcal{C}_3 in the forward direction is only 2^{-8} as it has only four active S-Boxes in the first round.

4.3 Message Modification, Matching, and Neutral Bits

In our distinguishers, we start constructing the internal differential boomerang pairs from the middle by fixing some bits of the intermediate states, which allows

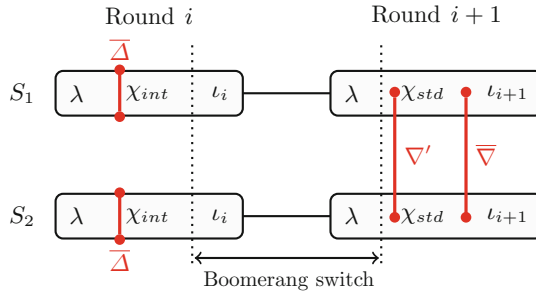

Fig. 2. The boomerang switch: middle of distinguishing structure where the differentials on the two halves of the primitive meet.

to pass low-probability events similarly to the rebound technique [25]. We define in particular the *boomerang switch* as the “middle” where we start constructing the state pairs to be the location where the two internal differential characteristics (or internal differentials) meet with the standard differential characteristic (see Fig. 2). Note that the two surrounding χ steps (denoted χ_{int} in the internal characteristic and χ_{std} in the standard characteristic on Fig. 2) usually have very low differential probabilities. However, since we start in the middle, we can fix partial state values such that these two steps are passed deterministically. Namely, this message modification technique allows to go through these two non-linear steps χ_{int} and χ_{std} without considering their probability.

Freedom Degrees. There are three conditions imposed on the state pair (S_1, S_2) at the boomerang switch: the first two come from the internal differential characteristics, i.e. $\delta(S_1) = \delta(S_2) = \overline{\Delta}$, while the third is from the standard characteristic, i.e. $S_1 \oplus S_2 = \overline{\nabla}$. Therefore, in total, we have 800 bits of freedom; that is, once we fix the first half of S_1 , then the second half of S_1 is fully determined, as well as the whole S_2 .

The limited degrees of freedom may lead to contradictions. For instance, if there is an active S-Box in the first halves of S_1 and S_2 , then the symmetry imposes that such S-Box must also be active in the second halves. If, in addition, these two halves differ in the bits that belong to the S-Boxes (which can occur when there is a non-zero internal difference at these bits), then it may not be possible to fix simultaneously the inputs to the S-Boxes in both of the halves.

Matching. To avoid such contradictions, we first have to make sure that *the internal characteristics and the standard characteristic can be matched*, i.e. there exist two states S_1 and S_2 at the boomerang switch (Fig. 2), that can pass the χ_{int} and χ_{std} steps and that can produce differences as specified by the characteristic. Our extensive computer experiments have shown that if the differences at the boomerang switch are not sparse, then the chance of a match is extremely low⁶.

⁶ This only confirms the fact that for boomerangs (both classical and internal differential), finding the two characteristics for f and g does not guarantee that the boomerang will work – see [28] for more details.

To overcome this issue, we find (S_1, S_2) that produce the required differences $\overline{\Delta}$ at the input of χ_{int} and $\overline{\nabla}$ at the output of the χ_{std} , but not necessarily have the correct differences right at the boomerang switch⁷. By relaxing the difference constraint at the boomerang switch, and by trying different standard characteristics⁸, we are able to match the characteristics.

Matching. This matching process is actually implemented by a message modification to partially fix values of the two states S_1 and S_2 to ensure that the boomerang can work by linking the two characteristics. As the output difference of χ_{int} is denser, we start the matching in the boomerang switch right at the output of χ_{int} (see Fig. 2). First, from the fixed output difference $\overline{\nabla}$ of χ_{std} , we produce all possible input differences ∇' , which defines the standard difference at the boomerang switch. We propagate each such difference to the output of χ_{int} , and then try to fix the values of all active S-Boxes of χ_{int} . If all the S-Boxes can be fixed, then the matching for χ_{int} is complete. During the matching, the values of some bits of the states S_1 and S_2 are being fixed, but there are still free (non-fixed) bits. We use the freedom of these bits to check if the active S-Boxes of χ_{std} can be passed. If so, then the matching is complete.

Neutral Bits. The above process fixes some bits of S_1 and S_2 but there are more free bits and they can be used as neutral bits [6]. Namely, if S_1 and S_2 have fixed bits according to the matching, then for any value of the free remaining bits, the active S-Boxes of χ_{int} and χ_{std} still produce the required differences.

4.4 Internal Differential Boomerang Distinguishers for Keccak- $p_{i,n}$

We use the internal differential boomerang technique to distinguish the round-reduced Keccak- f permutation. The boomerangs are based on the internal differentials and characteristics from Sect. 4.1, and the standard differential characteristics from Sect. 4.2. To produce a boomerang pair, we start at the boomerang switch, and we first find the values of the fixed bits of S_1 and S_2 according to the message modification, which allows to pass the two rounds that surround the boomerang switch. Then, we randomize the remaining neutral bits of the states and finally, from the two middle states, we produce the corresponding inputs and outputs. If the internal differences of each of the two inputs and the difference of the two outputs are as expected by the boomerang, then we have found the pair. Otherwise, we randomize again the neutral bits and repeat the procedure. An example of the overall description of the 8-round case is given in Fig. 3.

⁷ This is the reason why we have omitted specifying the differences at the output of the internal characteristics from Sect. 4.1, and at the input of the standard characteristics from Sect. 4.2.

⁸ The internal characteristic cannot be changed as its difference propagation is completely defined by the round constants RC_i . On the other hand, there are many different standard characteristics (built upon parity kernels) that hold with the same probability.

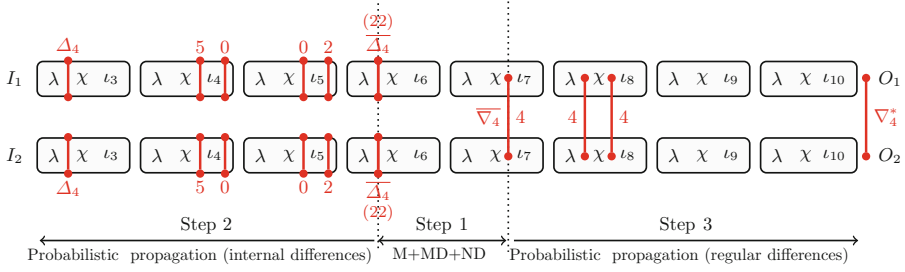

Fig. 3. Example of the internal boomerang distinguisher in the case of $\text{Keccak-p}_{3,8}$. In step 1, we first perform the matching (M), then the message modification (MD) and we use neutral bits (ND). We finish the construction of the pair of inputs (I_1, I_2) with the probabilistic propagations in Step 2 and 3.

The query complexity of producing a pair is determined by the differential probability of the characteristics in all the rounds but the middle two⁹. We claim distinguishers for $\text{Keccak-p}_{i,n}$ for some (i, n) because the complexity of finding a boomerang pair for $\text{Keccak-p}_{i,n}$ is significantly lower compared to the complexity of producing a boomerang pair (with the same conditions on the input and output differences) for a random permutation defined by Lemma 1. In the four boomerangs below, the input internal difference is determined either in 800 bits (when \mathcal{I}_3 is used) or in 64 bits (when \mathcal{ID}_4 is used), while the output difference is determined either in 1278 bits (when \mathcal{C}_3 is used) or in 118 bits (when \mathcal{C}_4 is used). Therefore, by Lemma 1, the query complexity of producing a boomerang pair in the case of a random permutation requires at least $2^{57.5}$ queries.

Depending on the starting round i of $\text{Keccak-p}_{i,n}$, the boomerang pairs are produced for two cases. First, when the permutation starts at round 0, for the boomerang we use the first internal differential characteristic \mathcal{I}_3 given in Sect. 4.1 and the standard characteristics $\mathcal{C}_3, \mathcal{C}_4$ given in Sect. 4.2. We can produce the boomerang pair for $\text{Keccak-p}_{0,6}$ by using the internal characteristic \mathcal{I}_3 and the standard characteristic \mathcal{C}_3 . As the probability of \mathcal{I}_3 without χ_{int} is 2^{-2} and the probability of \mathcal{C}_3 without χ_{std} is 1 (recall both of these two χ steps are passed with the message modification), we can produce the boomerang pair with $2 \cdot 2^2 \cdot 2^2 \cdot 1 = 2^5$ queries to the 6-round permutation. Similarly, we can produce boomerang pair for $\text{Keccak-p}_{0,7}$ (we combine \mathcal{I}_3 with \mathcal{C}_4) in $2 \cdot 2^2 \cdot 2^2 \cdot 2^8$ (the additional factor 2^8 is required to pass the 4 active S-boxes in the second round of \mathcal{C}_4), or approximately 2^{13} queries to the 7-round permutation.

Then, when the permutation starts at round 3, the boomerang uses the internal differential \mathcal{ID}_4 given in Sect. 4.1, and the standard characteristics $\mathcal{C}_3, \mathcal{C}_4$ from Sect. 4.2. The boomerang on $\text{Keccak-p}_{3,7}$, based on \mathcal{ID}_4 and \mathcal{C}_3 , produces a pair with $2 \cdot 2^{4.6} \cdot 2^{4.6} \cdot 1 = 2^{10.2}$ queries. For $\text{Keccak-p}_{3,8}$ (see Fig. 3), the

⁹ The cost of the message modification can be ignored because it is executed once, but it can be used for producing many boomerang pairs, thus on average it is negligible. The actual cost is around 2^8 .

Table 3. The internal differential boomerangs for $\text{Keccak-}p_{i,n}$ for $(i, n) \in \{(0, 6), (0, 7), (3, 7), (3, 8)\}$.

Rounds	Internal	Standard	Prob. of internal	Prob. of standard	Prob. of the boomerang	Complexity of finding a pair
6	\mathcal{I}_3	\mathcal{C}_3	2^{-68}	2^{-8}	2^{-140}	2^5
7	\mathcal{I}_3	\mathcal{C}_4	2^{-68}	2^{-16}	2^{-148}	2^{13}
7	\mathcal{ID}_4	\mathcal{C}_3	$2^{-48.6}$	2^{-8}	$2^{-105.2}$	$2^{10.2}$
8	\mathcal{ID}_4	\mathcal{C}_4	$2^{-48.6}$	2^{-16}	$2^{-113.2}$	$2^{18.2}$

boomerang is based on \mathcal{ID}_4 and \mathcal{C}_4 , and for producing a boomerang pair, we need $2 \cdot 2^{4.6} \cdot 2^{4.6} \cdot 2^8 = 2^{18.2}$ queries.

We have checked and confirmed the complexities of the four boomerangs given above. A summary of the distinguishers is given in Table 3.

5 Conclusions

We have presented the internal differential boomerang distinguishers, which are a combination of internal differentials and the boomerang technique. The new boomerangs can be used for cryptanalysis of functions and ciphers that have high-probability internal differentials. We have used the boomerangs to show non-randomness of reduced variants of the permutation $\text{Keccak-}f$. Based on truncated characteristics that hold with exceptionally high probability, and combined with a strong message modification, we have shown how to produce internal differential boomerang pairs for $\text{Keccak-}f$ reduced to 6 rounds with only 2^5 queries to the permutation, 7 rounds with 2^{13} queries, and up to 8 rounds with 2^{18} queries.

Our results significantly outperform in terms of practical complexity all the previous cryptanalysis of $\text{Keccak-}f$. We emphasize that the results do not pose threat to the security of the future SHA-3 standard as there is no known way to date to extend the proposed reduced-round permutation distinguishers to the full sponge construction based on the full 24-round $\text{Keccak-}f$ permutation. We were unable to extend our distinguishers to larger number of rounds while maintaining practical complexity. On the other hand, we leave as an open problem finding internal differential boomerang distinguishers that cover more rounds and that require theoretical complexity.

References

1. Aumasson, J.P., Meier, W.: Zero-sum distinguishers for reduced $\text{Keccak-}f$ and for the core functions of Luffa and Hamsi. rump session of Cryptographic Hardware and Embedded Systems-CHES 2009, 67 (2009)
2. Bertoni, G., Daemen, J., Peeters, M., Assche, G.V.: Cryptographic sponge functions (online)

3. Bertoni, G., Daemen, J., Peeters, M., Assche, G.V.: The Keccak reference (Version 3)
4. Bertoni, G., Daemen, J., Peeters, M., Assche, G.V., Keer, R.V.: Ketje v1. Submitted to the CAESAR competition, March 2014
5. Bertoni, G., Daemen, J., Peeters, M., Assche, G.V., Keer, R.V.: Keyak v1. Submitted to the CAESAR competition, March 2014
6. Biham, E., Chen, R.: Near-collisions of SHA-0. In: Franklin, M. (ed.) CRYPTO 2004. LNCS, vol. 3152, pp. 290–305. Springer, Heidelberg (2004)
7. Biryukov, A., Lamberger, M., Mendel, F., Nikolić, I.: Second-order differential collisions for reduced SHA-256. In: Lee, D.H., Wang, X. (eds.) ASIACRYPT 2011. LNCS, vol. 7073, pp. 270–287. Springer, Heidelberg (2011)
8. Biryukov, A., Nikolić, I., Roy, A.: Boomerang attacks on BLAKE-32. In: Joux, A. (ed.) FSE 2011. LNCS, vol. 6733, pp. 218–237. Springer, Heidelberg (2011)
9. Boura, C., Canteaut, A.: Zero-sum distinguishers for iterated permutations and application to KECCAK- f and Hamsi-256. In: Biryukov, A., Gong, G., Stinson, D.R. (eds.) SAC 2010. LNCS, vol. 6544, pp. 1–17. Springer, Heidelberg (2011)
10. Boura, C., Canteaut, A., De Cannière, C.: Higher-order differential properties of KECCAK and *Luffa*. In: Joux, A. (ed.) FSE 2011. LNCS, vol. 6733, pp. 252–269. Springer, Heidelberg (2011)
11. Canteaut, A. (ed.): FSE 2012. LNCS, vol. 7549. Springer, Heidelberg (2012)
12. Das, S., Meier, W.: Differential biases in reduced-round Keccak. In: [33], pp. 69–87
13. Dinur, I., Dunkelman, O., Shamir, A.: New attacks on Keccak-224 and Keccak-256. In: [11], pp. 442–461
14. Dinur, I., Dunkelman, O., Shamir, A.: Collision attacks on Up to 5 rounds of SHA-3 using generalized internal differentials. In: [27], pp. 219–240
15. Dinur, I., Dunkelman, O., Shamir, A.: Improved practical attacks on round-reduced Keccak. *J. Cryptology* **27**(2), 183–209 (2014)
16. Dinur, I., Morawiecki, P., Pieprzyk, J., Srebrny, M., Straus, M.: Practical complexity cube attacks on round-reduced Keccak sponge function. *IACR Cryptology ePrint Archive* 2014, 259 (2014)
17. Duc, A., Guo, J., Peyrin, T., Wei, L.: Unaligned rebound attack: application to Keccak. In: [11], pp. 402–421
18. Jean, J., Nikolic, I.: Internal differential boomerangs: practical analysis of the round-reduced Keccak- f permutation. *Cryptology ePrint Archive, Report* 2015/244 (2015)
19. Kelsey, J., Kohno, T., Schneier, B.: Amplified boomerang attacks against reduced-round MARS and serpent. In: Schneier, B. (ed.) FSE 2000. LNCS, vol. 1978, pp. 75–93. Springer, Heidelberg (2001)
20. Knudsen, L.R.: Truncated and higher order differentials. In: Preneel, B. (ed.) FSE 1994. LNCS, vol. 1008, pp. 196–211. Springer, Heidelberg (1995)
21. Kölbl, S., Mendel, F., Nad, T., Schläffer, M.: Differential cryptanalysis of Keccak variants. In: Stam, M. (ed.) IMACC 2013. LNCS, vol. 8308, pp. 141–157. Springer, Heidelberg (2013)
22. Kuila, S., Saha, D., Pal, M., Chowdhury, D.R.: Practical distinguishers against 6-round Keccak- f exploiting self-symmetry. In: [33], pp. 88–108
23. Lai, X.: Higher order derivatives and differential cryptanalysis. In: Blahut, R.E., Costello Jr., D.J., Maurer, U., Mittelholzer, T. (eds.) *Communications and Cryptography*, pp. 227–233. Springer, New York (1994)
24. Lamberger, M., Mendel, F., Schläffer, M., Rechberger, C., Rijmen, V.: The rebound attack and subspace distinguishers: application to Whirlpool. *J. Cryptology* **28**, 1–40 (2013)

25. Mendel, F., Rechberger, C., Schl affer, M., Thomsen, S.S.: The rebound attack: cryptanalysis of reduced Whirlpool and Gr stl. In: Dunkelman, O. (ed.) FSE 2009. LNCS, vol. 5665, pp. 260–276. Springer, Heidelberg (2009)
26. Morawiecki, P., Pieprzyk, J., Srebrny, M.: Rotational cryptanalysis of round-reduced Keccak. In: [27], pp. 241–262
27. Moriai, S. (ed.): FSE 2013. LNCS, vol. 8424. Springer, Heidelberg (2014)
28. Murphy, S.: The return of the cryptographic boomerang. IEEE Trans. Inf. Theory **57**(4), 2517–2521 (2011)
29. National Institute of Standards and Technology: Cryptographic Hash Algorithm Competition. <http://csrc.nist.gov/groups/ST/hash/sha-3/index.html>
30. National Institute of Standards and Technology: Draft FIPS 202: SHA-3 Standard: Permutation-Based Hash and Extendable-Output Functions
31. Naya-Plasencia, M., R ock, A., Meier, W.: Practical analysis of reduced-round KECCAK. In: Bernstein, D.J., Chatterjee, S. (eds.) INDOCRYPT 2011. LNCS, vol. 7107, pp. 236–254. Springer, Heidelberg (2011)
32. Peyrin, T.: Improved differential attacks for ECHO and Gr stl. In: Rabin, T. (ed.) CRYPTO 2010. LNCS, vol. 6223, pp. 370–392. Springer, Heidelberg (2010)
33. Pointcheval, D., Vergnaud, D. (eds.): AFRICACRYPT. LNCS, vol. 8469. Springer, Heidelberg (2014)
34. Wagner, D.: The boomerang attack. In: Knudsen, L.R. (ed.) FSE 1999. LNCS, vol. 1636, pp. 156–170. Springer, Heidelberg (1999)