

# How Did Dread Pirate Roberts Acquire and Protect his Bitcoin Wealth?

Dorit Ron<sup>(✉)</sup> and Adi Shamir

Department of Computer Science and Applied Mathematics,  
The Weizmann Institute of Science, Rehovot, Israel  
{dorit.ron,adi.shamir}@weizmann.ac.il

**Abstract.** The Bitcoin scheme is the most popular and talked about alternative payment scheme. One of the most active parts of the Bitcoin ecosystem was the Silk Road marketplace, in which highly illegal substances and services were traded. It was run by a person who called himself Dread Pirate Roberts (DPR), whose bitcoin holdings are estimated to be worth hundreds of millions of dollars at today's exchange rate. On October 1-st 2013, the FBI arrested a 29 year old person named Ross William Ulbricht, claiming that he is DPR, and seizing a small fraction of his bitcoin wealth. In this paper we use the publicly available record to trace the evolution of his holdings in order to find how he acquired and how he tried to hide them from the authorities. In particular, we trace the amounts he seemingly received and the amounts he seemingly transferred out of his accounts, and show that all his Silk Road commissions from the months of May, June and September 2013, along with numerous other amounts, were not seized by the FBI. This analysis demonstrates the power of data mining techniques in analyzing large payment systems, and especially publicly available transaction graphs of the type provided by the Bitcoin scheme.

**Keywords:** Bitcoin · Silk road · Dread pirate roberts · DPR

## 1 Introduction

Silk Road was an online marketplace which provided infrastructure for sellers and buyers to trade over the internet. In this sense it was similar to eBay, but with two major differences: most of the items offered for sale were illegal, and there was great emphasis on trying to ensure, as much as possible, the anonymity of both sellers and buyers. In particular, all the communication with the website was carried out through TOR (“The Onion Router”), in order to conceal the true IP addresses and therefore the identities of the network's users [1].

The Silk Road website was visited by hundreds of thousands of unique users from countries across the globe (about 30 % of whom indicated upon registration that they were from the United States) [2]. It grew rapidly, and in September 2013 had nearly 13,000 listings of drugs such as Cannabis, Ecstasy, etc. In addition, it offered a variety of services such as computer-hacking and items such as forged passports.

The only form of payment accepted on Silk Road was bitcoins. This is a decentralized form of electronic currency invented in 2008 by Satoshi Nakamoto [3]. In this scheme, all the transactions of all the users are publicly available (for instance via the so called block explorer [4]) but in an anonymous way [5,6]. Silk Road’s payment system essentially consisted of an internal bitcoin “bank”, where every Silk Road user had to hold at least one account in order to conduct transactions on the site. These accounts were stored on wallets maintained on servers controlled by Silk Road. Each user had to deposit bitcoins in advance into his Silk Road account, and then he was free to use them in order to buy multiple items on Silk Road. When a purchase was made, the appropriate number of bitcoins was first transferred to an escrow account maintained by Silk Road, pending completion of the transaction. When the transaction was completed, the buyers’ bitcoins were transferred from the escrow account to the Silk Road bitcoin address of the vendor involved in the sale. Silk Road also used a so-called “tumbler” which, as the site explained, “sent all payments through a complex, semi-random series of dummy transactions making it nearly impossible to link your payment with any coins leaving the site” [2].

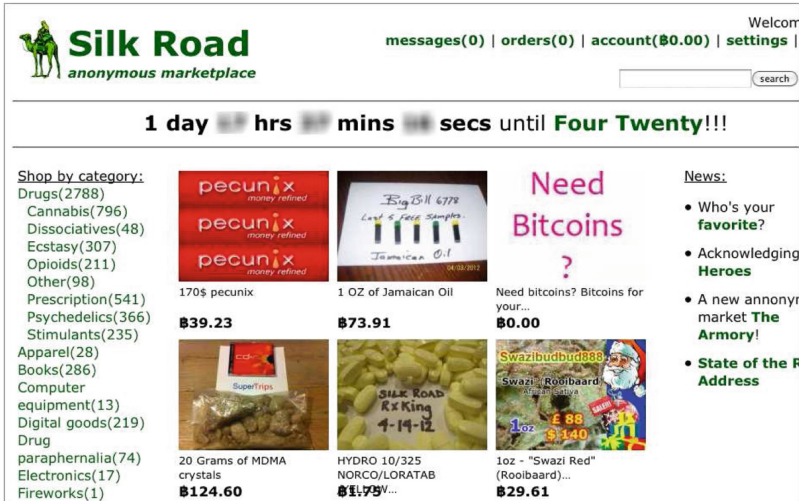
The paper is organized as follows. Section 2 describes what is known about the alleged owner and operator of the Silk Road marketplace website. In Sect. 3 we trace backwards all the accounts and amounts which are related to those which were seized by the FBI when they arrested Ulbricht and confiscated his computer, in order to better understand his financial activity and mode of operation. Finally, in Sect. 4 we discuss the power and limitations of such data mining techniques in various investigative scenarios.

## 2 Who Operated the Silk Road Marketplace?

The Silk Road marketplace opened in February 2011. Throughout its existence, it was operated by an unknown person who called himself Dread Pirate Roberts (DPR), who controlled every aspect of its operation: He acquired the computer infrastructure, maintained the Silk Road website, and determined vendor and customer policies (including deciding what can be sold on the site). He was paid a commission for each transaction, which varied depending on the size of the transaction: 10% for the first \$50 down to 1.5% for purchases over \$1000 [1]. On October 1-st 2013 the FBI arrested in San Francisco an American citizen named Ross William Ulbricht, claimed that he is DPR, and seized control of the Silk Road website (see Fig. 1). As expected, a different website calling itself “The New Silk Road” was opened on November 6, 2013 [7], offering a similar collection of illegal items for sale (see Fig. 2).

According to a press release from the United States attorney’s office [2], Silk Road was used during its two and a half year existence by several thousand drug dealers to distribute hundreds of kilograms of illegal drugs, to supply unlawful services to more than a hundred thousand buyers, and to launder hundreds of millions of dollars derived from these transactions. The site generated sales revenue of more than 9.5 million bitcoins and collected commissions from these

## The old site of the Silk Road



## Seized by the FBI on October 1<sup>th</sup> 2013



Fig. 1. The Silk Road's front page [1] and the seized FBI's announcement.

# Reopened on November 6th 2013



# The selection on the new Silk Road



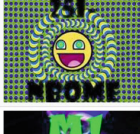
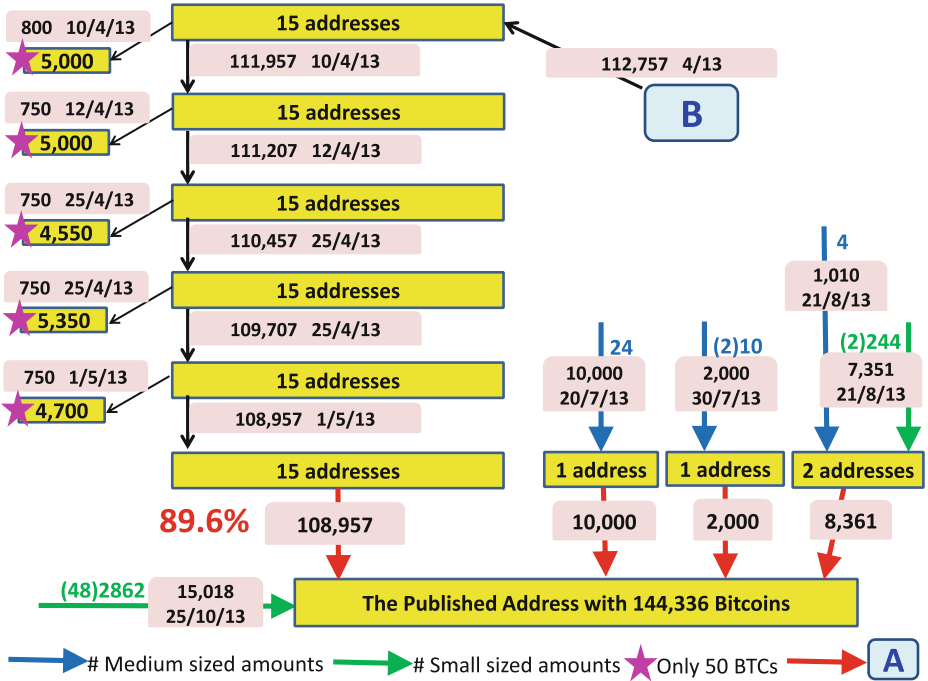
item	vendor	price	
 1g DMT Freebase	ringo deathstarr	B0.35672880	add to cart
 7g (1/4oz) P.Cubensis Powder	magicted	B0.16030500	add to cart
 FREE 25i-NBOMe 1mg blotter sample FREE	eternalpsy	B0.00000000	add to cart

Fig. 2. A message from the administrator of the new Silk Road announcing the reopening of the new site and its new front page [8].

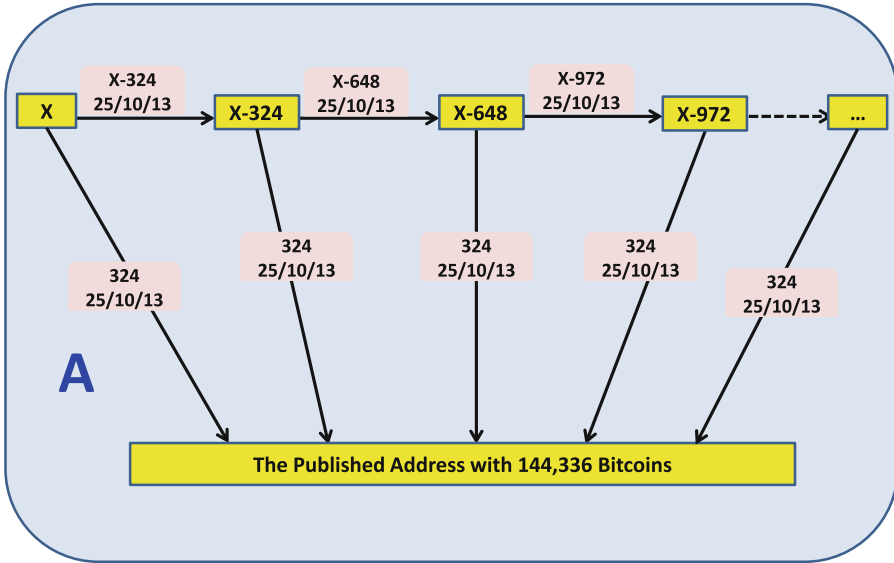


**Fig. 3.** The backtracking of the published address (at the bottom). 89.6% of the entire seized amount originated from only 19 addresses shown above the published address and connected to it by four red arrows, explained in Fig. 4. (The identities of the published address and the 19 directly connected to it are given in Appendix A). The remaining 10.4% was seized from 2,862 small accounts grouped into 48 transactions as shown in green to the left of the published address. In the (x)y notation on the arrows, x indicates the number of involved transactions and y indicates the number (not the sum!) of the transferred amounts. The sum and the associated date of the transfer are written on the arrow. If there is just one transaction with y “from” accounts, (x) is omitted. Green arrows are associated with multiple small amounts of less than 60 BTCs and blue arrows are associated with multiple medium amounts of less than 1,000 BTCs.

sales totaling more than 600,000 bitcoins. At the bitcoin exchange rate in effect when the Silk Road website was seized, these figures are roughly equivalent to \$1.2 billion in sales and \$80 million in commissions. At today’s exchange rate, DPR’s wealth is estimated to be several hundred million dollars, and only a small fraction of this amount was seized so far by the FBI.

### 3 Tracing Backwards the Published Account

At the time of his arrest on October 1-st 2013, Ulbricht was using a laptop computer, which was seized by the FBI. Through forensic analysis which lasted 25



**Fig. 4.** Each red arrow in Fig. 3 represents a large number of bitcoins found on DPR’s computer. It was seized by transferring it into an FBI-controlled account via a sequence of transactions, each moving exactly 324 bitcoins (except in the last transaction). Starting from the top-left with X bitcoins in a DPR-controlled account, 324 were seized and the remaining  $X-324$  were moved to an intermediate address from which again 324 were seized, etc., until the entire amount was seized. All these transactions took place on 25/10/13 between 01:27:54 and 06:50:27.

days, federal law enforcement agents found on this laptop a bitcoin wallet containing approximately 144,336 bitcoins [2]. Immediately afterwards, on October 25-th between 01:27:54 to 06:50:27, the FBI transferred the full amount (then worth about \$28 million) in a series of 446 transactions to a single new account that they created and controlled. Each one of the first 445 transactions transferred exactly 324 BTCs (which is the numeric equivalent of “FBI” on a phone’s keypad), and the last one transferred the remaining 156 BTCs, as described in Fig. 4. On the same day, they published the identity of the new account [9] which contained all the seized bitcoins, but even if they had refrained from doing so, the public nature of the Bitcoin scheme, the highly unusual series of identical transactions and the fact that the receiving address had one of the highest balances in the Bitcoin scheme, would have revealed its identity in any case. In the block explorer this address is titled “DPR Seized Coins”.

An interesting comment we would like to make is that the notion of seizing bitcoins from a suspect’s laptop is much trickier than the notion of seizing cash from a suspect’s safe, even if all the necessary keys are found by the FBI in both cases. In the case of cash, once the money is hauled away, it is no longer available to the suspect. However, let us assume that the Bitcoin community had noticed

the unusual activity, and had refused to pick up these FBI-initiated transactions for verification as part of the official block chain. In this case, it would not help the FBI that they set up the new account and had initiated those transfers - their holdings would not be recognized as valid, and thus they would not be able to exchange or auction them off. In addition, they could still be used by either the suspect or by any one of his accomplices who happens to know the secret key! Even if the community had been late in recognizing these events and some miners would have picked up those transactions in the meantime, a 51% majority of the computing power available to miners could have forked the block chain just before these transactions, and grown a longer side chain which would invalidate all the blocks that contain the FBI transactions. However, by now it is probably too difficult to take such measures, and the seized bitcoins are no longer usable by DPR.

Immediately after hearing about DPR's arrest, we decided to use the publicly available transaction data in the block chain in order to understand and analyze DPR's mode of operation, and in particular how he acquired and how he tried to conceal his bitcoin wealth. Our starting point was the FBI-controlled account, and we tried to trace it backwards. Out of the 446 incoming transactions into the FBI account, 48 had many sending accounts, and the remaining 398 had between one and four sending accounts. Figure 3 summarizes the structure of the accounts which were the immediate predecessors of the FBI account. The FBI address is shown at the bottom of the figure. The five arrows entering it, one green and four red, represent its entire incoming flow of bitcoins. The green arrow indicates many transactions involving relatively *small* amounts of less than 60 BTCs each, and the notation along it indicates that a total of 15,018 bitcoins were transferred on October 25-th 2013 in 48 transactions with a total number of 2,862 "from" addresses included in all of them (the same notation will be used later on for the blue arrows, which represent *medium* sized transfers of between 60 and 1,000 BTCs). When there is only a single transaction, we omit the (1) from the label of the edge. The other 398 transactions backtracked to precisely 19 addresses which contained 89.6% of the 144,336 bitcoins which were seized from DPR's wallet. As described in Fig. 3, the four rightmost addresses received a total of 20,361 bitcoins during July and August 2013 from 244 small amounts and 38 medium ones, but most of the bitcoins which were seized by the FBI were kept by DPR in the 15 accounts shown to the left. He moved all these bitcoins simultaneously from one set of 15 accounts into another set of 15 accounts several times in April and May 2013, but then kept them in the same set of 15 accounts created on May 1-st 2013 until his arrest on October 1-st 2013. Each of these 15 addresses were used to send on the same dates exactly 50 bitcoins to certain accounts. On the left we show five such addresses marked by magenta asterisk, meaning that all its incoming transactions are exactly of 50 bitcoins. Backtracking some of these 50-bitcoin-transactions leads to several accounts which had hundreds of transactions with a huge total volume of hundreds of thousands of bitcoins.



**Table 1.** Bitcoins seemingly received by DPR over time

Date	Amount	# of incoming transactions		# of small amounts	# of medium amounts	How much was seized	How much was moved
10/12	12,564	2	-	540	-	5,502	7,062
11/12	42,263	6	-	1,596	-	12,463	29,800
12/12	5,275	-	1	-	50	0	5,275
1/13	63,000	5	3	2,580	71	41,350	21,650
2/13	6,000	2	-	586	-	2,650	3,350
3/13	44,642	1	3	466	66	43,442	1,200
4/13	5,000	-	-	-	6	3,550	1,450
5/13	0	-	-	-	-	0	0
6/13	0	-	-	-	-	0	0
7/13	27,018	2,862	3	8,586	34	27,018	0
8/13	8,361	2	1	244	4	8,361	0
9/13	0	-	-	-	-	0	0
	<b>214,123</b>					<b>144,336</b>	<b>69,787</b>

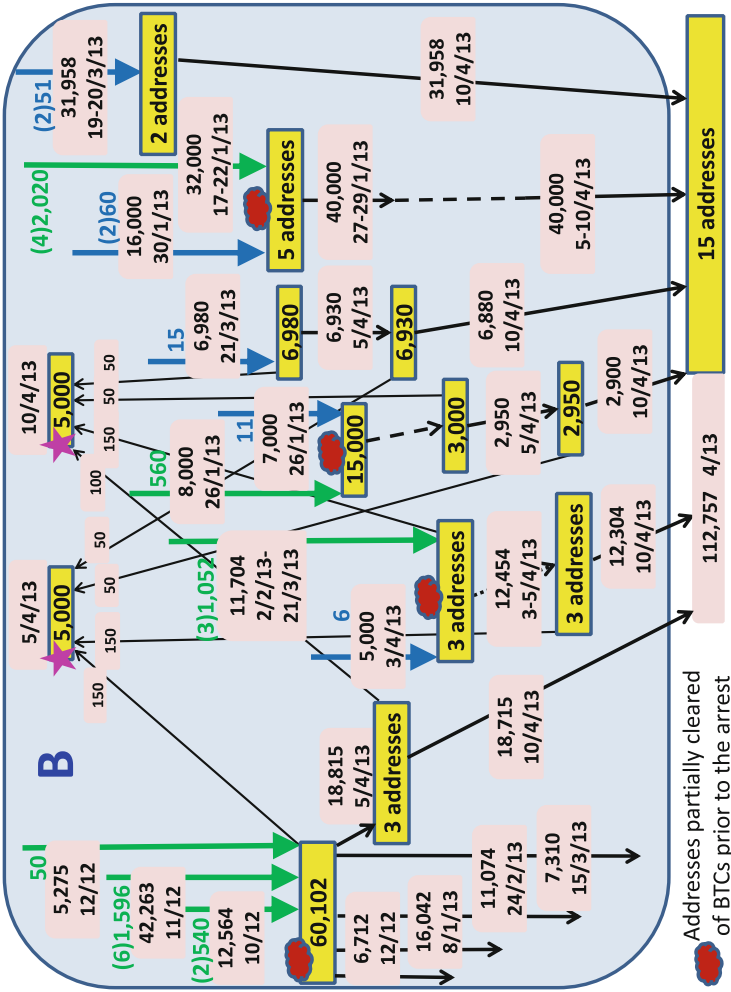
One of the largest among these accounts had more than 100,000 incoming BTCs and the last transaction in the account happened at 8AM on October 1-st 2013, just before DPR’s arrest. It is not clear whether they belong to DPR, and none of these bitcoins were seized by the FBI. Further backtracking of the 15 addresses which are believed by the FBI to belong to DPR are shown in Fig. 5.

The remaining 4 addresses at the bottom of Fig. 3 behave differently. From right to left are shown: two addresses which contributed 8,361 bitcoins which had been accepted on August 21, 2013 from one transaction of 1,010 bitcoins involving four medium sized amounts and two other transactions of 7,351 bitcoins involving 244 small amounts. Next to the left, there is one address with 2,000 bitcoins and another with 10,000, both originating in July, 2013.

Figures 3 and 5 summarize all the large-amount transactions which contributed bitcoins to accounts that the FBI believes were owned by DPR. We stopped the backtracking when the amounts became too small or when the number of involved addresses became too large. We traced 30 such origins: seven already appear in Fig. 3: six on the right on top of the published address and one entering it from the left. The other 24 are shown in Fig. 5. For instance, the nine transactions in the top-left took place already in 2012 and contributed 60,102 BTCs to a single address. Interestingly, four addresses had at some point many more bitcoins than the number finally seized by the FBI. These addresses are marked by a brown cloud.

In Table 1 we summarize all the incoming transactions which seemingly belonged to DPR that our analysis discovered. We arranged them according to the month (left most column) they entered the accounts. For each month,





**Fig. 5.** Further backtracking of the largest accounts that the FBI claims to be owned by DPR reveals additional chunks of bitcoins that were there at some point, but were transferred elsewhere before October 1-st 2013 and thus were not seized. The sum of all these amounts is about 70,000 BTCs as listed in Table 1. Most of it was included in the addresses marked with a brown cloud, and their identities are listed in Appendix B.

from left to right, we describe the total number of received BTCs; the total number of transactions (how many transactions involving only small amounts and how many involving medium amounts); how many accounts participated in those transactions (small and medium amounts); how many BTCs were seized on 25/10/12 and finally how many BTCs were moved by DPR prior to his arrest. An interesting observation is that there is a huge variability in the amount he earned which we are aware of, which is inconsistent with the reasonable assumption that the total volume of business carried out on Silk Road was increasing at a roughly constant rate. In particular, the months of May, June and September 2013 are completely missing from this list. Assuming that DPR continued to receive at least some commissions from Silk Road during these months, it seems likely that he was simply using a different computer during these periods, which the FBI had not found or was unable to penetrate. In addition, it is evident that about a third of the bitcoins in these accounts, were moved out prior to his arrest. As it is believed that the Silk Road marketplace generated sales revenue of more than 9.5 million bitcoins with an average commission rate of 6.67%, we can conclude that he received about 633,000 BTCs in commissions. Consequently, the amounts seized by the FBI represent only about 22% of these commissions, while the amounts that we have identified, which are depicted in our figures, seem to represent about a third.

## 4 The Power and Limitations of such Data Mining Techniques

Data mining is an increasingly popular technique to try to make sense out of huge graphs of entities and their relationships, such as the metadata of phone conversations or the friendship structure of social networks. In this paper we tried to use such techniques in order to analyze the behavior of a particular person named Ross William Ulbricht in the huge graph of all the bitcoin transactions carried out so far. This is a challenging task due to the (partial) anonymity provided by the Bitcoin scheme. However, in this particular case, the actions taken by the FBI in October 2013 had provided us with a plausible starting point in the form of 19 accounts that the FBI claimed (and Ulbricht initially denied and later admitted) belonged to him. It is reasonable to assume that the FBI had also used some data mining techniques to find its initial leads into the case, but the real evidence which would prove such an association beyond any reasonable doubt in a criminal case is likely to come only from the forensic analysis of Ulbricht's seized laptop, and not from the circumstantial graph-theoretic evidence.

Given such a starting point, our goal was to identify additional accounts which belonged to the same entity. Here we step into a potential minefield, since unlike the FBI we do not possess any forensic evidence and thus all our identifications are conjectured rather than proven. None of the conclusions in this paper can be presented as a smoking gun in a court of law, but they are quite convincing: For example, if we see several sets of 15 accounts whose bitcoins are all moved in parallel on the same day from one set to the next, the balance

of probability indicates that if the last set is known to belong to Ulbricht, then all the other sets are also likely to belong to him. However, it is still possible that someone else will come out of the blue and conclusively prove that he is the rightful owner of all the other sets.

One of the most interesting challenges in such a data mining project is to decide which pattern of behavior forms a sufficiently strong evidence to make a *prima facie* case that two accounts belong to the same entity (or alternatively, how careful should a privacy-conscious person be in diversifying his activities in order to avoid such identification). For example, credit card companies often use a particular pattern of ATM withdrawals (times, places, amounts, etc.) to try to fingerprint its customers, and to flag any deviation from such a pattern as a cause for suspicion (but not as a proof of guilt!). Can we claim that two bitcoin accounts which interact in very similar ways with the rest of the system necessarily belong to the same entity? Our personal opinion is that for the sake of an academic analysis, we do not need proofs beyond any reasonable doubt in order to draw such conclusions, provided that we carefully describe our methodology and explain why our conclusions are the best way to explain the currently available data. This is exactly the same level of assurance that all researchers in biology, medicine, and the social sciences are using when they discover a new correlation between two things such as eating substance A and getting disease B: This could be a complete coincidence, but it is still a noteworthy discovery which could have important consequences.

**Acknowledgments.** This research was supported by a research grant provided by the Citi Foundation. We would like to thank Ronen Basri, Uriel Feige, Michal Irani, Robert Krauthgamer, Boaz Nadler, Moni Naor and David Peleg from the Computer Science and Applied Mathematics Department of the Weizmann Institute of Science for many interesting and informative discussions. We would also like to thank Aharon Friedman for his help in acquiring and processing the bitcoin data base. Finally, we would like to thank all the members of the Bitcoin community that we talked to, and especially Meni Rosenfeld.

## Appendix A: The Identities of Some of the Addresses in Fig. 3

We list below the identities of the addresses appearing at the bottom of Fig. 3. The first one is the one with the 144,336 DPR Seized Coins. The next 19 are the addresses from which 89.6% of the above amount was received. In the figure, these 19 addresses are grouped (from left to right) in four subgroups of 15,1,1 and 2 addresses as listed below.

## Appendix B: The Identities of Some of the Addresses in Fig. 5

We list below the identities of the addresses marked with a brown cloud in Fig. 5. There are 10 addresses which are grouped (from left to right) in four groups of

DPR Seized Coins 1FfmbHfnpaZjKFvyi1okTjJJusN455paPH  
 1/15 1M2TBBkAESfyyKsmqDKsLxD6oC4bvM8WQx  
 2/15 1JwL9bWB4RJ29Cc3ccW6M1mWA8hrfidPzm  
 3/15 1NfvKnqRk8wSutfWitJdMSF1cAMfG4Q9sG  
 4/15 1FAVjwR4ZRRUYuZKdGwbWhDrfASP5Vg5vk  
 5/15 1B6UsR4HK5Zn7ggN4pUZkhwJt8c65Th67G  
 6/15 19XmwMdRspwNN55eYLincbf1xDenNajU8R  
 7/15 1Fdi7uUBiYQogFEgTEsPCQZv2qC8WRLwGD  
 8/15 1Nt6HwcysgRMehHHwoKV9KkswmBQSLmicQ  
 9/15 1HGVEWBZ4MBEUw9VGf6AbQNMtoCZ8BUyj3  
 10/15 1KQoi5wAq6zCuQmL67adAMipWZ8apui6hP  
 11/15 1Pt42pTpy1i4D1XfftvuvL7CMLMo4tVF8v  
 12/15 1AG6FDBg934ikpGPeeik3rabnSea8r6wGJ  
 13/15 1FvxZn2dkbz8AQnBkEgRq8ttH6czwADwQW  
 14/15 17YqeNog4t5YgbKLgh99UwSjUQAFEjuFtN  
 15/15 14xCmiFcdLuiTfeH6r1vgLUjro2qskCzp  
 1/1 19GUoeGq7hf9KyYfRVLx68SA4NJ4uDDQRF  
 1/1 1Az2kHto3AqCQmmnFAXtcPkGdLqNWRxnSV  
 1/2 1EdsvQfKkV8dWo179AgHMH52XAZ4gcco2  
 2/2 1Bbwcvmtx3xd1GDLJopCX4PgfT5PkqDfa

1,3,1 and 5 addresses. In the forth group there is actually only one interesting address, the one from which 8,000 BTCs were moved prior to the FBI’s action. These six relevant addresses are listed below.

1/1 1NnqM24fFeAGf7NWxmhhFkQAciPqeWo3L  
 1/3 1Gx49gkDDeGvPGuWNdzvVz7pP984VX1wf  
 2/3 14xrNSxfQ2FwmsaQNKAYY4ENMsrDnhQW4x  
 3/3 1FpzHKV3yeK1jh21VG1cq5emVPuS6z3wSS  
 1/1 1Esg7ZoXh1oytd7GwJagHoq3AijfSbAeLg  
 1/5 1HBxVRovvUW17wn8L9JGkxVeb5ibTU1bjs

**References**

1. Christin, N.: Traveling the Silk Road: a measurement analysis of a large anonymous online marketplace. In: Proceedings of the 22nd International World Wide Web Conference (WWW’13), Rio de Janeiro, Brazil, May 2013, pp. 213–224 (2013). <https://www.andrew.cmu.edu/user/nicolasc/publications/Christin-WWW13.pdf>
2. The United States attorney’s Office: Manhattan U.S. Attorney Announces Seizure of Additional \$28 Million Worth of Bitcoins Belonging to Ross William Ulbricht, Alleged Owner and Operator of Silk Road Website, 25 October 2013. <http://www.justice.gov/usao/nys/pressreleases/October13/SilkRoadSeizurePR.php>

3. Nakamoto, S.: Bitcoin: a peer-to-peer electronic cash system (2008)
4. The blockexplorer. <http://blockexplorer.com/>
5. Ron, D., Shamir, A.: Quantitative analysis of the full bitcoin transaction graph. In: Sadeghi, A.-R. (ed.) FC 2013. LNCS, vol. 7859, pp. 6–24. Springer, Heidelberg (2013)
6. Meiklejohn S., Pomarole M., Jordan G., Levchenko K., McCoy D., Voelker G.M., Savage S.: A fistful of bitcoins: characterizing payments among men with no names. In: Proceedings of the 2013 Conference on Internet Measurement Conference, pp. 127–140 (2013). <http://cseweb.ucsd.edu/~smeiklejohn/files/imc13.pdf>
7. Greenberg A.: ‘Silk Road 2.0’ Launches, Promising a Resurrected Black Market for the Dark Web, Forbes, 6 November 2013. <http://www.forbes.com/sites/andygreenberg/2013/11/06/silk-road-2-0-launches-promising-a-resurrected-black-market-for-the-dark-web/>
8. Cox, J.: Good News, Drug Users - Silk Road is Back!, 6 November 2013. <http://www.vice.com/read/good-news-drug-users-silk-road-is-back>
9. Greenberg A.: FBI Says It’s Seized \$28.5 Million in Bitcoins from Ross Ulbricht, Alleged Owner of Silk Road, Forbes, 25 October 2013. <http://www.forbes.com/sites/andygreenberg/2013/10/25/fbi-says-its-seized-20-million-in-bitcoins-from-ross-ulbricht-alleged-owner-of-silk-road/>