

Green Energy and Technology

Kasthurirangan Gopalakrishnan  
Wynand JvdM Steyn  
John Harvey *Editors*

# Climate Change, Energy, Sustainability and Pavements



 Springer

# **Green Energy and Technology**

More information about this series at <http://www.springer.com/series/8059>

Kasthurirangan Gopalakrishnan  
Wynand JvdM Steyn · John Harvey  
Editors

# Climate Change, Energy, Sustainability and Pavements

 Springer



*Editors*

Kasthurirangan Gopalakrishnan  
Department of Civil, Construction  
and Environmental Engineering  
Iowa State University  
Ames, IA  
USA

John Harvey  
Department of Civil and Environmental  
Engineering  
University of California  
Davis, CA  
USA

Wynand JvdM Steyn  
Department of Civil Engineering  
University of Pretoria  
Pretoria  
South Africa

ISSN 1865-3529

ISBN 978-3-662-44718-5

DOI 10.1007/978-3-662-44719-2

ISSN 1865-3537 (electronic)

ISBN 978-3-662-44719-2 (eBook)

Library of Congress Control Number: 2014951139

Springer Heidelberg New York Dordrecht London

© Springer-Verlag Berlin Heidelberg 2014

This work is subject to copyright. All rights are reserved by the Publisher, whether the whole or part of the material is concerned, specifically the rights of translation, reprinting, reuse of illustrations, recitation, broadcasting, reproduction on microfilms or in any other physical way, and transmission or information storage and retrieval, electronic adaptation, computer software, or by similar or dissimilar methodology now known or hereafter developed. Exempted from this legal reservation are brief excerpts in connection with reviews or scholarly analysis or material supplied specifically for the purpose of being entered and executed on a computer system, for exclusive use by the purchaser of the work. Duplication of this publication or parts thereof is permitted only under the provisions of the Copyright Law of the Publisher's location, in its current version, and permission for use must always be obtained from Springer. Permissions for use may be obtained through RightsLink at the Copyright Clearance Center. Violations are liable to prosecution under the respective Copyright Law.

The use of general descriptive names, registered names, trademarks, service marks, etc. in this publication does not imply, even in the absence of a specific statement, that such names are exempt from the relevant protective laws and regulations and therefore free for general use.

While the advice and information in this book are believed to be true and accurate at the date of publication, neither the authors nor the editors nor the publisher can accept any legal responsibility for any errors or omissions that may be made. The publisher makes no warranty, express or implied, with respect to the material contained herein.

Printed on acid-free paper

Springer is part of Springer Science+Business Media ([www.springer.com](http://www.springer.com))

# Editorial Advisory Board

To assure the highest quality, each chapter in this book has been carefully peer-reviewed by the Editors with assistance from the following members of the Editorial Advisory Board. The valuable contributions of these expert referees in assisting with the review process are greatly appreciated.

**Imad L. Al-Qadi** Illinois Center for Transportation, University of Illinois at Urbana-Champaign, Urbana, IL, USA

**Halil Ceylan** Institute for Transportation, Iowa State University, Ames, IA, USA

**Norbert Delatte** Civil and Environmental Engineering Department, Cleveland State University, Cleveland, OH, USA

**Thomas Harman** Pavement and Materials Technical Service Team (TST), FHWA Resource Center, Office of Technical Services, Baltimore, MD, USA

**Michael Heitzman** National Center for Asphalt Technology (NCAT), Auburn, AL, USA

**A. Veeraragavan** Department of Civil Engineering, Indian Institute of Technology (IIT), Madras, Chennai, India

**Peter C. Taylor** National Concrete Pavement Technology Center (CP Tech Center), Iowa State University, Ames, IA, USA

# Contents

<b>1</b>	<b>Pavement Life Cycle Assessment . . . . .</b>	<b>1</b>
	Yue Huang and Tony Parry	
<b>2</b>	<b>Application of LCA Results to Network-Level Highway Pavement Management . . . . .</b>	<b>41</b>
	John Harvey, Ting Wang and Jeremy Lea	
<b>3</b>	<b>The Product Process Service Life Cycle Assessment Framework to Estimate GHG Emissions for Highways. . . . .</b>	<b>75</b>
	Amlan Mukherjee and Darrell Cass	
<b>4</b>	<b>Anticipating and Responding to Pavement Performance as Climate Changes . . . . .</b>	<b>127</b>
	Andrew Dawson	
<b>5</b>	<b>Climate Change Scenarios and Their Potential Effects on Transportation Infrastructure Systems . . . . .</b>	<b>159</b>
	Wynand JvdM Steyn	
<b>6</b>	<b>Effect of Pavement Surface Conditions on Sustainable Transport. . . . .</b>	<b>173</b>
	Karim Chatti and Imen Zaabar	
<b>7</b>	<b>Permeable Pavements and Storm Water Management . . . . .</b>	<b>247</b>
	Miklas Scholz	
<b>8</b>	<b>Pervious Concrete. . . . .</b>	<b>261</b>
	John T. Kevern	

<b>9</b>	<b>Photocatalytic Pavements</b> . . . . .	275
	Joel K. Sikkema, James E. Alleman, Tom Cackler, Peter C. Taylor, Ben Bai, Say-Kee Ong and Kasthurirangan Gopalakrishnan	
<b>10</b>	<b>Warm Mix Asphalt.</b> . . . . .	309
	Martins Zaumanis	
<b>11</b>	<b>Sustainability Issues Surrounding Unpaved Roads</b> . . . . .	335
	Phil Paige-Green	
<b>12</b>	<b>Sustainable Airport Pavements</b> . . . . .	353
	Dominique M. Pittenger	
<b>13</b>	<b>Sustainable Pavement Management</b> . . . . .	373
	Gerardo Flintsch and James Bryce	
<b>14</b>	<b>Sustainable Pavement Preservation and Maintenance Practices</b> . . . . .	393
	Douglas D. Gransberg, Susan L. Tighe, Dominique Pittenger and Maria Catalina Miller	
<b>15</b>	<b>Reclaimed Waste Materials in Sustainable Pavement Construction.</b> . . . . .	419
	Animesh Das and Aravind Krishna Swamy	
<b>16</b>	<b>Cool Pavements</b> . . . . .	439
	K. Wayne Lee and Steven Kohm	
<b>17</b>	<b>Powering Traffic Intersections with Wind and Solar Energy.</b> . . . .	455
	Mo Zhao and Anuj Sharma	
<b>18</b>	<b>Energy Harvesting from Pavements.</b> . . . . .	481
	Andrew Dawson, Rajib Mallick, Alvaro García Hernandez and Pejman Keikhaei Dehdezi	

# Chapter 1

## Pavement Life Cycle Assessment

Yue Huang and Tony Parry

**Abstract** Efficient use of fuel and material resources, reduction in greenhouse gas emissions and control of environmental impacts have become important to the construction industry, including pavement engineering. Life cycle assessment, including carbon footprinting, is one important way of estimating the scale and environmental impacts of resource use and emissions to the environment. LCA results can be used for product development, benchmarking and policy making (e.g. investment decisions). Decision makers need to have confidence in the results of LCA studies and this will require that they are conducted in compliance with standards, in a consistent and transparent way. This chapter provides a short introduction to LCA before describing typical inputs and outputs required for pavement LCA and discussion of LCA standards as applied to road pavements. Some existing pavement LCA studies and tools are introduced and briefly reviewed. Finally, a framework for pavement LCA is suggested along with a checklist for conducting these studies and a note on challenges for developing the method in this area.

### 1.1 Introduction to Life Cycle Assessment

#### *1.1.1 Background: Why There Is a Need for Life Cycle Study*

The use of Life Cycle Assessment (LCA) for road pavement comes at a time when ‘sustainability’ is a common pursuit of the construction industry. Resource efficiency, energy conservation and carbon reduction now appear on the agenda of

---

Y. Huang (✉)

Liverpool John Moores University, Byrom Street, Liverpool L3 3AF, UK  
e-mail: y.huang@ljmu.ac.uk

T. Parry

Nottingham Transportation Engineering Centre, University of Nottingham, University Park,  
Nottingham NG7 2RD, UK  
e-mail: tony.parry@nottingham.ac.uk

© Springer-Verlag Berlin Heidelberg 2014

K. Gopalakrishnan et al. (eds.), *Climate Change, Energy, Sustainability and Pavements*,  
Green Energy and Technology, DOI 10.1007/978-3-662-44719-2\_1

public and private sector construction clients. The accuracy of financial information stipulated by reporting legislation such as the Sarbanes-Oxley Act (Sarbanes and Oxley 2002) may well be required for environmental performance too, such as the carbon footprint. The compliance cost is pushed higher, and in future the top management of companies could well be held liable for disclosing false information. The 'green' pursuit comes with a requirement for impartial and scientifically sound measurement of the environmental impacts, with a holistic approach. Well-defined targets and indicators, against which companies can measure their progress towards sustainable construction, are paving the way for delivery of sustainability objectives. To put a strategy into practice companies need to identify, by means of hard evidence, the priority areas for action and develop a set of targets and indicators for improvement in all aspects and dimensions of the business. These can then be communicated to stakeholders and the public, and/or used to benchmark their performance against competitors. LCA results can form an important component of this evidence.

#### **1.1.1.1 Requirements for Sustainable Road Pavement Construction**

A consensus was formed in 2005 around six key impact areas within the United Kingdom (UK) asphalt industry, based on the findings of an expert review set up by the Refined Bitumen Association (RBA), the Quarry Products Association (QPA) and the Highways Agency. The report was published by the Transport Research Laboratory (TRL). These impact areas are (Parry 2005):

- Design for long-life pavements: promote resource efficiency by adopting quality paving materials and innovative maintenance techniques;
- Increase re-use and recycling in road works: use recycled and secondary materials where possible;
- Whole life cost analysis: address the life-time, rather than the short-term cost, considering both the agency's and the users' cost when selecting materials, layer thickness, interval of maintenance and the service level to restore, etc.;
- Implement an effective Environmental Management System (EMS): reduce site emissions, pollution incidents and the waste volume; reduce water and energy use;
- Health and Safety (H&S): improve H&S of the work place; provide employees with training and equal opportunities; enhance staff's environmental awareness, and
- Responsible procurement, selling and marketing: know the clients' expanding expectation; engage suppliers and contractors in commitment to sustainable practice; provide unequivocal and evidence based statements for stakeholders.

Of the items above, some are obvious and paramount; others may be marginal and traded, in a project, against one another. Companies aiming for environmental labelling need to ensure that their pursuit of a 'green' product or practice will not end up with undesirable consequences caused by shifting problems elsewhere or

trading off one for another, possibly worse, impact. Claims of sustainable construction based simply on one aspect such as materials saving or energy reduction are disputable and hard to compare. An LCA approach to measuring a range of environmental impacts can help avoid this problem. Where standard practice is adopted the results can be used as part of decision making in specification and procurement.

### **1.1.1.2 Emerging Technologies**

A life cycle approach is gaining ground in meeting the needs of sustainable construction (Young et al. 2002). The increasing use of recycled and secondary materials in road pavements needs up-to-date studies on associated environmental impacts including the energy use, emissions and leaching, etc. Simply diverting the waste from other industries to use in roads is already questioned for not reducing but potentially increasing carbon dioxide (CO<sub>2</sub>) footprint (Wenzel 2006). For new materials (e.g. warm mix asphalt, roller compacted concrete) and emerging construction techniques (e.g. dual laying, in situ recycling) we need to ensure that the gains in reducing construction impacts will not be offset by potentially higher impacts at operation/maintenance stage or through the supply chain. Procurement documents for construction products can ask for prescriptive environmental assessment such as LCA (BRE 2009). Already accredited by a number of industries such as chemicals and automobiles, LCA is now being accepted and practiced by the road industry to measure and compare the key environmental impacts of its products and allied processes, throughout pavement life.

### **1.1.1.3 ‘Hot Spot’ Analysis**

To meet sustainability targets such as carbon reduction, companies need to first of all, review their supply chain and business activities, to identify the products and/or processes that cause the highest impacts. This is to ensure the most cost effective measures can be taken to meet that target, i.e. the ‘hot spot’ area can be tackled first where small changes may make a substantial difference. This is particularly important to companies whose activities are spread to wide geographic areas through the supply chain, or whose products have long standing effect on the environment. Figure 1.1 is an example of this ‘hot spot’ identification by the media industry.

## ***1.1.2 Introduction to LCA***

Developed in the 1970s, LCA is a relatively new environmental analysis technique. It quantifies the environmental burdens of a product across its life time from raw material acquisition, through production, transport, use and final disposal: a cradle-to-grave analysis. Figure 1.2 is a simple illustration of what a typical LCA of

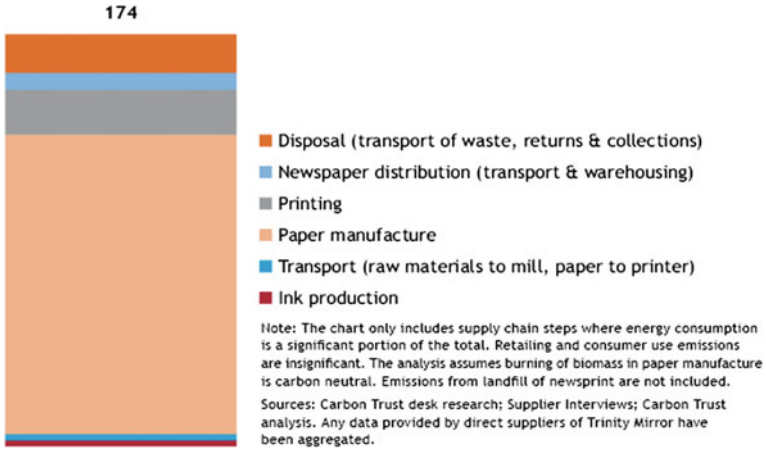

**Fig. 1.1** Carbon footprint of the Daily Mirror (g CO<sub>2</sub> per newspaper sold) (CarbonTrust 2006)

building projects includes. The Society of Environmental Toxicology and Chemistry (SETAC) worked on the coordinated development of LCA across Europe and the United States. International standards regarding LCA (ISO 14040 series) have existed since 1997. Through its growth, LCA is actively practiced by a number of industries to monitor and report their eco-efficiency and environmental stewardship.

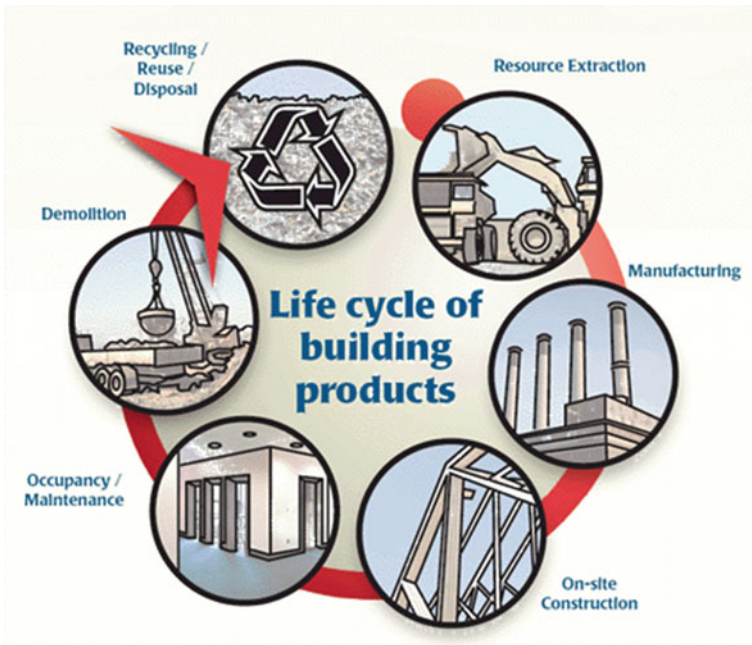

**Fig. 1.2** Life cycle of building projects (source Athena 2014)



Some early examples include house building materials in France (Peuportier 2001), the German automobile industry (Mildenberger and Khare 2000), and world renowned consumer goods companies (e.g. BASF, Proctor and Gamble). Application in civil engineering started initially as a tool for assessing waste management options. Besides giving knowledge of a product’s environmental performance, LCA results are also able to support marketing or environmental labelling. For instance, the Type III Environmental Product Declaration (EPD), which enables informed comparison between products fulfilling the same function, requires quantified environmental information based on independently verified LCA results (BSI 2006a).

### 1.1.2.1 The ISO 14040 Series

There are four phases in a LCA study. The main work includes the development of an inventory, in which all the significant environmental burdens (input and output) will be quantified and compiled. This is followed by an impact assessment, calculating and presenting results in a predefined way that supports comparison or further analysis. The four phases of LCA are illustrated in Fig. 1.3 and described below. For definitions of terms see the ISO standards. This chapter does not attempt a full introduction to the subject and more help for beginners can be found in the Hitch Hiker’s Guide to LCA (Baumann and Tillman 2004) and for more advanced users, the International Reference Life Cycle Data System (ILCD) Handbook (ILCD 2010).

1. Goal and Scope Definition—the first phase of LCA, setting the boundary, level of detail, and time frame of the study. It also influences assumptions and options made throughout the study such as system boundary, data sources and impact categories.

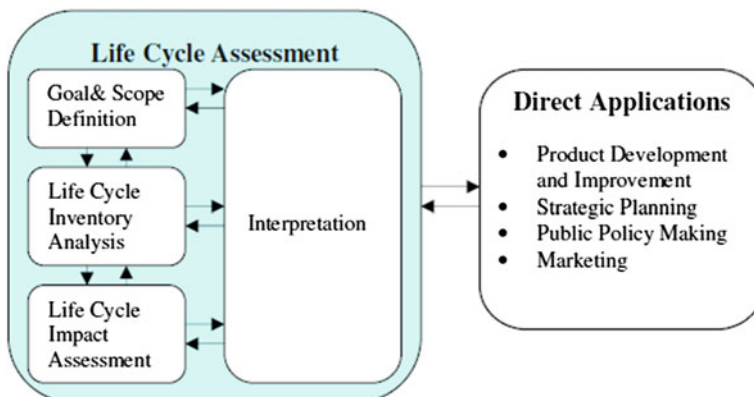

Fig. 1.3 Phases in life cycle assessment (BSI 2006b)

2. Life Cycle Inventory (LCI) analysis—a relatively objective step that collects and compiles data of environmental inputs (raw materials, energy, etc.) and outputs (emissions, leaching, solid waste, etc.) within the system defined previously.
3. Life Cycle Impact Assessment (LCIA)—evaluation of LCI results during which an indicator and a characterization model will be selected for each impact category. LCI results assigned to the category are calculated using the characterization model, and the results presented by the indicator. This is a phase of LCA where some subjective choices are made for a particular application. It consists of both mandatory and optional elements (an example of conducting the first three steps for a pavement LCA is shown in Table 1.3) that include:
  - (a) Impact Category Definition—select a set of categories to which LCI results are allocated, alongside the definition of category indicator and characterization model;
  - (b) Classification—assign LCI results to impact categories;
  - (c) Characterization—calculate indicator results within each impact category;
  - (d) Normalization (optional)—calculate the magnitude of indicator results relative to reference information;
  - (e) Grouping (optional)—assign impact categories into predefined groups (descriptive) and possibly rank them (normative);
  - (f) Weighting (optional)—convert and possibly aggregate indicator results across impact categories using numerical factors based on value choice, a further step towards a single-number result, and
  - (g) Data Quality Analysis (optional)—understand the reliability as well as limitations of data used in the study, and the sensitivity of indicator results in significant areas.
4. Interpretation—a phase to compile, check and evaluate the results from LCIA or LCI phase, to form conclusions and recommendations. In general, the results of LCA can assist in the following areas:
  - (a) Identify opportunities to improve the environmental performance of a product or process in the life cycle period;
  - (b) Decision-making in industry, government body or non-governmental organizations (e.g. strategic planning, priority setting, policy making), and
  - (c) Marketing (e.g. environmental labelling, reporting, and product declaration).

### 1.1.2.2 Life Cycle of a Road Pavement, Typical Inputs and Outputs

Road pavement construction and rehabilitation projects differ from one another in terms of materials and equipment use, transport and placement method. The construction of an asphalt road pavement can be characterized as having the following processes, as illustrated in Fig. 1.4, for a typical study. Other types of road pavement can be modelled in similar flowcharts.

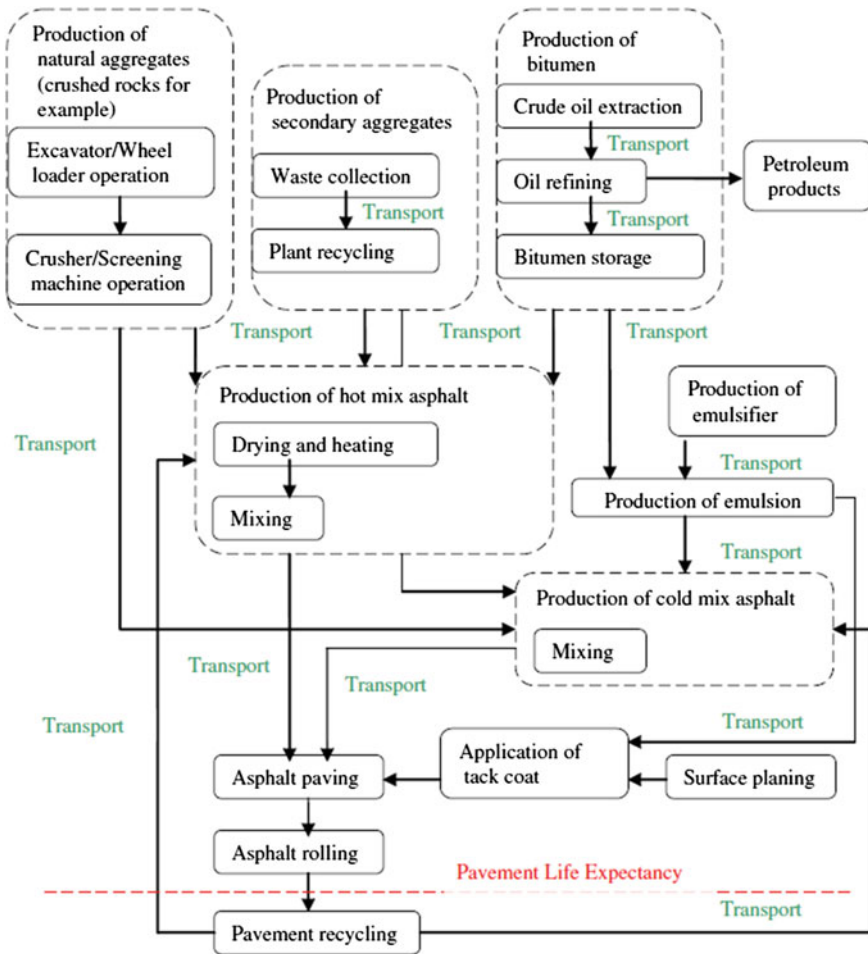

Fig. 1.4 Processes in the road pavement life cycle (Huang 2007)

- Raw and secondary materials sourcing and product manufacture (e.g. asphalt, concrete, recycled materials);
- Transport of raw materials to mixing plant, and products to site;
- Construction on site, including machinery use and office hire, and
- Maintenance and rehabilitation, including recycling or disposal of unserviceable materials, involving some or all of the same activities, usually on a smaller scale than original construction.

For each of the unit processes above, the task for LCA is to quantify the environmental inputs (e.g. aggregates in tonnes, diesel in litres) and outputs (e.g. CO<sub>2</sub> in kg). Table 1.1 is an example of data for energy consumption collected for

**Table 1.1** Energy inputs to hot mix asphalt production (Stripple 2000)

	Unit	A modern plant in Scandinavia	Sweden	EAPA <sup>a</sup>	Netherlands	UK
Electricity	MJ/tonne asphalt	25	36	18–29	38	32
Fuel oil	MJ/tonne asphalt	251	285	360	310	340

<sup>a</sup> EAPA European Asphalt Pavement Association

hot mix asphalt production. It demonstrates that there might be substantial differences between data from different sources.

The data collected for all unit processes will then be compiled and presented in an inventory. Associated processes ought to be separated for clarity, but for convenience of data, processes for which the inputs and/or outputs are impossible to separate are usually presented together. Table 1.2 is an example of the Life Cycle Inventory (LCI) for bitumen production, from research undertaken by the European bitumen association (Eurobitume).

The inventory results are difficult to interpret or compare, thus a LCA often needs to proceed to the impact assessment phase (although not every study will). During Life Cycle Impact Assessment (LCIA), the inventory results will go through classification and characterization (as a minimum). The output will be a characterization table (Table 1.3 is an example), with results presented by predefined impact category indicators, such as Global Warming Potential (GWP), usually over 100 years (measured as kg CO<sub>2</sub>-eq., the mass of CO<sub>2</sub> that would have the equivalent impact of the three gasses (CO<sub>2</sub>, CH<sub>4</sub> and N<sub>2</sub>O) in the inventory, see report by the Intergovernmental Panel on Climate Change (IPCC 2007), or Depletion of Fossil Fuels, measured in MJ (the energy released by burning the amounts of the various fuels used). A ‘carbon footprint’ is a LCA reporting GWP as the only impact category.

The Characterisation Factor, or Indicator, normalises the inventory outputs within each Impact Category, to a single number, generally by reporting the equivalent impact for one of the inventory items (e.g. CO<sub>2</sub>-eq).

### 1.1.3 Methodological Choices in Pavement LCA

In the Goal and Scope definition, some key decisions need to be made, such as system boundary, allocation method, data sources etc. It is vital to make the process transparent and justifiable, as methodological choices can potentially change the LCA results substantially. This is particularly important in a comparative LCA, comparing more than one product with the same function. Anyone using the results of LCA study should be able to find what these decisions were, and how they were made.

**Table 1.2** Life cycle inventory of bitumen (Eurobitume 2011)

Production of 1 tonne of bitumen (process without infrastructure)	Unit	Crude oil extraction	Transport	Refinery	Storage	Total
<i>Raw material</i>						
Crude oil	kg	1,000				1,000
<i>Consumption of energy resources</i>						
Natural gas	kg	18.9	0.4	0.58	0.19	20.1
Crude oil	kg	17.5	9.3	11.9	2.2	40.9
Coal	kg	0	0.21	0.49	0.33	1.03
Uranium	kg	0	0.00001	0.00003	0.00002	0.0001
<i>Consumption of non energy resources</i>						
Water	I	0	48	72	24	143
<i>Emissions to air</i>						
CO <sub>2</sub>	g	99,135	30,078	37,200	7,831	174,244
SO <sub>2</sub>	g	290	334	130	27	781
NO <sub>x</sub>	g	270	436	52	11	770
CO	g	524	70	16	3	613
CH <sub>4</sub>	g	548	16	25	6	595
Hydrocarbon	g	0.015	4.6	3.5	38.7	46.8
NMVOOC	g	297	15	15	3	331
Particulates	g	132.6	12.7	12.6	3.4	161.2
<i>Emissions to water</i>						
Chemical oxygen demand	g	0	130	176	30	336
Biological oxygen demand	g	0	128	166	30	324
Suspended solids	g	0	9.4	16.4	4.1	30.0
Hydrocarbon	g	6.9	40.9	52.5	9.5	109.8
Phosphorous compounds	g	0	2.52	6.77	4.79	14.1
Nitrogen compounds	g	0	0.95	4.40	1.51	6.86
Sulphur compounds	g	0	63	166	119	348
<i>Emissions to soil</i>						
Hydrocarbon (oils)	g	8.1	42.6	54.9	10.0	176

### 1.1.3.1 Scope/Boundary

Figure 1.5 illustrates the system boundary of a LCA study. Road pavement LCAs can be cradle-to-gate (raw materials to the gate of the product (asphalt, concrete) plant), to-laid (including construction), or to-grave (the whole lifecycle including maintenance, use and demolition). The choice of a cradle-to-grave LCA needs to consider the complexity of the use phase and uncertainty in disposal scenarios.

**Table 1.3** Characterization factors from literature (Huang 2007)

Impact category		Inventory loading	Characterisation factor	Figure	Source <sup>a</sup>
Depletion of minerals		Aggregates	Tonne minerals	1	
		Bitumen		1	
Depletion of fossil fuels		Energy (MJ)	Tonnes oil equivalent (TOE)	1/41868	BRE
Global warming potential		CO <sub>2</sub>	kg CO <sub>2</sub> -eq. (100 years)	1	IPCC
		N <sub>2</sub> O		23	
		CH <sub>4</sub>		296	
Stratospheric ozone depletion		CFC <sub>11</sub>	kg CFC <sub>11</sub> -eq.		WMO
Acidification		SO <sub>2</sub>	kg SO <sub>2</sub> -eq.	1	IIASA
		NO <sub>x</sub>		0.7	
		NH <sub>3</sub>		1.88	
Photo oxidant (ground-level ozone, or fog) formation		SO <sub>2</sub>	kg C <sub>2</sub> H <sub>4</sub> -eq.	0.048	CML
		NO <sub>x</sub>		0.028	
		CO		0.027	
		CH <sub>4</sub>		0.006	
		NMVOC		1.0	
Human toxicity	Emission to air	SO <sub>2</sub>	kg 1,4-dichlorobenzene-eq.	0.096	CML
		NO <sub>x</sub>		1.2	
		CO		2.4	
		HC		5.7E + 05	
		NMVOC		0.64	
		PM <sub>10</sub>		0.82	
		NH <sub>3</sub>		0.1	
		Heavy metals		5.1E + 05	
	Emission to fresh water	HC	2.8E + 05		
		Heavy metals	2.4E + 03		
Eco-toxicity	Emission to air	NMVOC	kg 1,4-dichlorobenzene-eq.	3.2E - 11	CML
		HC		1480	
		Heavy metals		8.6E + 05	
	Emission to fresh water	HC	1.1E + 04		
		Heavy metals	1.9E + 05		
Eutrophication		NO <sub>x</sub>	kg PO <sub>4</sub> -eq.	0.13	CML
		NH <sub>3</sub>		0.35	
		COD		0.022	
		Phosphate		1	

(continued)

**Table 1.3** (continued)

Impact category	Inventory loading	Characterisation factor	Figure	Source <sup>a</sup>
	Nitrate		0.1	
Noise	Noise/1000 vehicle * km	DALY	1.3E - 03	SAEFL
Depletion of landfill space	Solid waste	m <sup>3</sup> landfill space		

<sup>a</sup> BRE Building Research Establishment; IPCC Intergovernmental Panel on Climate Change; WMO World Meteorological Organisation; IIASA International Institute of Applied System Analysis; CML Institute of Environmental Sciences, Leiden University; SAEFL Swiss Agency for the Environment, Forests and Landscape

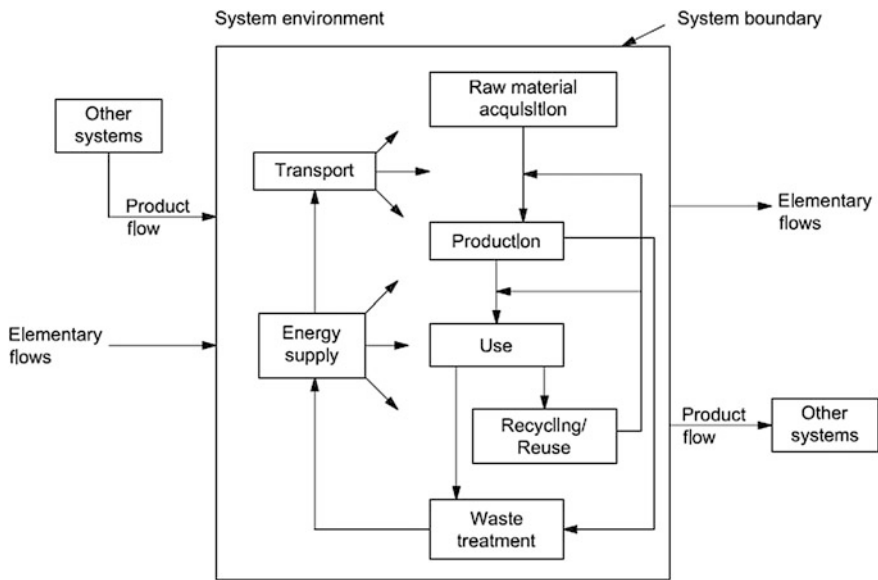

**Fig. 1.5** Methodological choices in LCA (BSI 2006b)

**1.1.3.2 Functional Unit**

Functional unit is defined in ISO 14040 as “quantified performance of a product system for use as a reference unit”. The function of a road pavement is to provide safe, durable, comfortable and economic driving. Functional unit in road pavement LCA can be defined as a length and width of the carriageway surface. The lane width will depend on the grade of the road and whether pavement of non-carriageway use (e.g. hard shoulder) is included. Durability, or pavement service life, is another important element in defining the functional unit, as is the traffic level carried. A well-defined functional unit might therefore, be a surface area of pavement to

carry a certain design traffic for a defined number of years (including necessary maintenance and rehabilitation). Typical flaws seen in the definition of function unit include:

- Functional unit defined in material quantity, such as a tonne of pavement material. This type of functional unit ignores the in situ performance of the material, e.g. stiffness, which will determine the thickness needed for a given design traffic, and
- Functional unit defined without consideration of material durability, such as a kilometre of road for 1 year. This type of functional unit ignores the durability which will determine how often the material needs to be replaced, and thus the quantity of waste and new materials needed, and associated transport and site activities.

### 1.1.3.3 Allocation

Allocation of environmental burdens, among co-products or at end-of-life (EOL) recycling, has been applied in road pavement LCA, and the allocation methods are likely to be put under the spotlight when the LCA results are reviewed or challenged (Chen et al. 2010; Sayagh et al. 2010). Allocation methods should be declared because they can make a significant difference to the results of an LCA study (Huang et al. 2013).

Co-product allocation is important for materials such as bitumen from a refinery, where a variety of other oil products are derived and the environmental impacts of the refinery will need to be split amongst the various products. For concrete where industrial by-products are introduced to partially replace the Portland cement, it should be considered how much of the impact, if any, of the primary product/process should be allocated to the by-product (e.g. for ground granulated blast furnace slag, where the slag is a by-product of iron smelting). ISO 14040 specifies that allocation can be made based upon physical (e.g. mass, volume) or economic value of the products.

Where materials are recycled at EOL an impact 'credit' may be included in the inventory to reflect the reduced impacts of using recycled rather than new materials. Recycling requires both the production and use of recyclable materials and their subsequent reuse. How the credit is allocated between the inventory of the original recyclable material and the recyclate varies between LCI and LCA studies. Assuming future recycling of materials in the LCI of their original production can have a significant impact and such an assumption is often made in industry data.



### ***1.1.4 Introduction to Different Types of LCA***

#### **1.1.4.1 Process Based Versus Input–Output Based**

A process based LCA analyses the environmental inputs and outputs of individual processes. It provides an insight into the impacts of the individual processes and can support ‘hot spot’ analysis, and if reported in enough detail, is transparent in terms of which processes generate which impacts. The limitation is that a boundary has to be drawn in terms of which processes are included and which not. This can be an arbitrary decision, often based upon practical aspects such as complexity or data availability. This is at a risk of eliminating some, possibly large, impact processes from the analysis (e.g. manufacture of production plant and equipment). This leads to ‘truncation error’ of unknown size.

As opposed to this ‘bottom-up’ approach, the input–output based approach is based on estimates of the total impacts of ‘aggregated’ processes, or economic sectors (e.g. construction). A factor relating economic value to environmental impact is derived for each sector and the impacts of a project are calculated based upon its value. This ‘top-down’ approach is less time consuming, and is able to undertake industry sector based analysis which would not be possible using the process based approach. However, it will not support detailed analysis and the methodology is still developing.

A third approach is a hybrid one, i.e. process based analysis for high impact processes or those under direct influence of those conducting the study, and input–output based analysis for other processes. There is methodological difficulty in setting the boundary, such that the benefits of both approaches can be utilized, and data collection can be practical. A good introduction to the three approaches is given using a carbon footprint example by Wiedmann (2009).

#### **1.1.4.2 Comparative LCA**

Broadly speaking, comparative LCA studies present results for two products fulfilling the same functions e.g. glass bottles and aluminium cans for beverage packaging, asphalt and concrete pavements for road transport. The main benefits of conducting comparative LCAs are that results are presented in a context and the magnitude is made easy to understand. Comparative LCAs call for uniformity in defining functional unit, data quality, impact assessment method and other methodological choices, for fairness. Comparative LCAs should always be carried out in conformity with the ISO 14040 series, especially when results are to be verified by third party and disclosed to the public (BSI 2006a). BS EN 15804 (BSI 2012) provides a useful guide to the information that should be disclosed about reported results.

### 1.1.4.3 Static Versus Dynamic

It is acknowledged that LCA results are not sensitive to time or location (Guinee 2002). That means that X tonnes of CO<sub>2</sub> released over 1 year in a plant will have the same characterization results as vehicles emitting X tonnes of CO<sub>2</sub> along the carriageway over 10 years. The use of a single time horizon provides only one perspective on the LCA outcomes which could introduce an inadvertent bias into LCA results, especially in toxicity impact categories, where severity of the incidents depending on both quantity and timing will affect to a great extent the health and safety (H&S) risk assessment outcome. The lack of temporal information is an important limitation of LCA. Guo and Murphy (2012) concluded that LCAs lacking explicit interpretation of the degree of uncertainty and sensitivity analyses are of limited value. A dynamic LCA approach is proposed to improve the accuracy of LCA by addressing the inconsistency of temporal assessment. This approach consists of first computing a dynamic Life Cycle Inventory (LCI), considering the temporal profile of emissions. Then, time-dependent characterization factors are calculated to assess the dynamic LCI for real-time impact scores for any given time horizon. A case study by Levasseur et al. (2010) demonstrated that the use of global warming potentials for a given time horizon to characterize greenhouse gas emissions, leads to an inconsistency in the time frame chosen for the analysis. Comparison of the results obtained with both traditional and dynamic LCA approaches shows that the difference can be important enough to change the conclusions.

### 1.1.5 The Use of LCA Results

The LCA results can be used in a number of ways, most notably in product development, environmental reporting or labelling. ISO 14040 (BSI 2006b) has indicated where the LCA findings can be used to demonstrate compliance with other ISO standards, such as:

- (a) Environmental management systems (e.g. ISO 14001) and environmental performance evaluation (e.g. ISO 14031), for example identification of significant environmental aspects of the products and services of an organization;
- (b) Environmental labels and declarations (e.g. the ISO 14020 series), or
- (c) Integration of environmental aspects into product design, development and communication, for example reporting carbon footprint (e.g. ISO 14064).

There are potentially a number of practical applications in private and public organizations. The ISO 14040 (BSI 2006b) recommends that the life cycle approach, principles and framework be applied to techniques, methods and tools such as:

- (a) Environmental Impact Assessment (EIA);
- (b) Environmental Management Accounting (EMA);

- (c) Assessment of policies (models for recycling, etc.);
- (d) Sustainability assessment: economic and social aspects are not included in LCA, but the procedures and guidelines could be applied by appropriate competent parties;
- (e) Substance and Material Flow Analysis (SFA and MFA);
- (f) Hazard and risk assessment of chemicals;
- (g) Risk analysis and risk management of facilities and plants;
- (h) Product stewardship, supply chain management;
- (i) Life Cycle Management (LCM);
- (j) Design briefs, life cycle thinking, and
- (k) Life Cycle Costing (LCC).

### 1.1.5.1 Product Development

Pavement construction requires large quantities of quarry materials, which in recent years are more and more being replaced by recycled or secondary materials. Binders like bitumen or cement come from dedicated manufacturing processes. Transport and placement of pavement materials uses a variety of trucks and machinery. It is difficult to estimate what process/product in this complex supply chain has the highest environmental impacts. LCA, due to its cradle-to-grave approach, will be able to answer such questions and prioritize action aimed at reducing the environmental impacts.

Comparative LCA studies, in particular, have the benefit of providing information for choosing the optimal materials/processes based on predefined criteria (e.g. carbon footprint, or Global Warming Potential) amongst others. Robust engineering design has to be carried out, to ensure the comparisons are made on a ‘level-playing field’, e.g. considering in situ performance and durability factors when defining the Functional Unit as discussed previously. Table 1.4 is an example of how LCA results have resulted in some key performance indicators (KPI) for five designs using different materials for constructing a road pavement. Note that these figures are per m<sup>2</sup>, which as previously stated, is not usually a complete Functional Unit.

**Table 1.4** LCA findings of road pavement designs, per m<sup>2</sup> pavement (Huang 2010)

Models <sup>a</sup>	Construction			Construction and maintenance		
	Energy (MJ)	CO <sub>2</sub> (kg)	Cost (£)	Energy (MJ)	CO <sub>2</sub> (kg)	Cost (£)
1: SFRC-RCC	130.3	78.9	31.2	173.4	90.4	55.7
2: Steel bar wet mix	84.8	148.4	63.2	127.9	160.0	87.8
3: SFR wet mix	235.3	121.1	55.4	278.4	132.6	80.0
4: Unreinforced Concrete	207.4	139.4	59.0	250.5	150.9	83.5
5: Flexible pavement	123.7	52.9	36.1	230.9	81.3	81.5

<sup>a</sup> SFRC-RCC Steel fibre reinforced concrete-roller compacted concrete, SFR Steel fibre reinforced

### 1.1.5.2 Company Reporting (e.g. PAS 2050)

Publicly Available Specification (PAS) 2050:2008, *Specification for the assessment of the life cycle greenhouse gas emissions of goods and services*, addresses the single-impact category of Global Warming Potential to provide a standardized and simplified implementation of process-based LCA methods for assessing greenhouse gas (GHG) emissions from products. The widespread interest in PAS 2050 from individuals and organizations, confirmed that there is a need for clarification, certainty, and specified requirements in the life cycle analysis of a product's carbon footprint. The use of PAS 2050 to refine, clarify, and simplify existing LCA methods and standards has resulted in specific tools for GHG assessment being developed (e.g. asPECT (Wayman et al. 2011), see Sect. 1.2.2.6). Climate science and GHG assessment techniques are both evolving areas and it will be necessary to review the approach taken by PAS 2050 in the future (Sinden 2009).

### 1.1.5.3 Marketing, Sustainability Rating Systems

LCA results can be used to label the environmental performance of a product or project. Carbon footprint is increasingly used for construction materials for sales purposes and benchmarking against competitors' products. In civil infrastructure projects, a lot more environmental impacts, together with social and economic ones are factored into sustainability rating systems.

#### CEEQUAL

The Civil Engineering Environmental Quality Assessment and Awards Scheme (CEEQUAL) was developed with the support of the UK Institution of Civil Engineers (ICE). It measures the sustainability performance of a civil infrastructure project in 12 areas, a total of 2,000 points are allocated to these areas, weighted as follows in the fourth version of scheme description and assessment process handbook (ICE 2008):

- Project management—10.9 %;
- Land use—7.9 %;
- Landscape—7.4 %;
- Ecology and biodiversity—8.8 %;
- Historic environment—6.7 %;
- Water resources and water environment—8.5 %;
- Energy and carbon—9.5 %;
- Material use—9.4 %;
- Waste management—8.4 %;
- Transport—8.1 %;
- Effects on neighbours—7.0 %, and
- Relations with local community and other stakeholders—7.4 %.

CEEQUAL is usually completed at the end of the design and construction when solid evidence to support the scoring is available. Interestingly, road projects

measured by CEEQUAL scored systematically low under the ‘energy and carbon’ criterion (Nicholson 2010). An investigation indicated that the low uptake of LCA may be the reason. In addition, LCA also helps to gain credits in some of the other areas (e.g. material use, waste management, transport).

### **Greenroads**

This sustainability rating system for road design and construction projects was developed by University of Washington and CH2M HILL to quantify the best practice of a road project in the following categories (Muench et al. 2011):

- Project requirements—mandatory;
  - I. Environment and water—21 points;
  - II. Access and equity—30 points;
  - III. Construction activities—14 points;
  - IV. Materials and resources—23 points;
  - V. Pavement technologies—20 points, and
- Custom credit—10 points.

The mandatory ‘project requirements’ are intended to capture the most critical ideals of sustainability. There are 37 ‘voluntary credits’ in five groups, each is assigned a point value (1–5 points) depending on its weighted impacts, for a total of 108 points. In addition, Greenroads allows a project to create and use ‘custom credit’, subject to approval by Greenroads, for a total of up to 10 points. LCA results are required by both the ‘project requirements’ (mandatory) and ‘materials and resources’ section.

Road authorities, design consultants and contractors may wish to use CEEQUAL or Greenroads point values or certification levels for new build projects, or as metrics by which they can measure and manage their sustainability efforts, that are either voluntary or prescriptive. As seen from above, the LCA (full or carbon) studies are identified as a means to gain credits in both sustainability rating schemes.

## **1.2 Review of Pavement LCA Studies and Resources**

### ***1.2.1 A Timeline of LCA Literature***

The US Environmental Protection Agency (EPA) is hosting an index of international LCA resources including books and journals, websites and conference proceedings, software and databases, and case studies since 1998 (EPA 2014a). EPA’s pilot study in the late 1990s demonstrated that LCA can help select the environmentally preferable method for asphalt pavement treatment, even on a tight budget and time schedule (Schenck 2000). A hybrid I–O (input–output) model was used in Japan looking at the life cycle emissions of CO<sub>2</sub> from a motorway covering both the

construction and operation stage (Inamura et al. 2000). The potential values of ‘generic data sets’, ‘technology assessment’ and ‘marketing’ are viewed by the cement industry as ‘high’ or ‘mid-high’ in using LCA (Young et al. 2002). In addition to compliance with the ISO standards, a robust LCA study must also be supported by good quality data, which normally come from LCA databases or previous studies.

- In 1993–1995, the Swedish Environmental Research Institute (IVL) developed a LCI model for road construction and maintenance. The second version was released in 2001 (Stripple 2001);
- In 1996, the Technical Research Centre of Finland (VTT) published a comparative LCA study on the environmental impacts of asphalt and concrete pavements (Hakkinen and Makela 1996). Later, in 2001, an LCA model was developed addressing the use of industrial by-products (coal fly ash (CFA), blast furnace slag (BFS), etc.) in roads (Mroueh et al. 2001);
- In 1997–1999, Eurobitume conducted a partial (cradle-to-gate) LCI study on paving grade bitumen (Eurobitume 1999). A new version in 2011 included Polymer-Modified Binder (PMB) and bitumen emulsion (Eurobitume 2011);
- Building for Environmental and Economic Sustainability (BEES) was developed by the US National Institute of Standards and Technology (NIST) in 2002. The model calculates the environmental and economic performance of nearly 200 building products using the LCA approach (Kneifel and Greig 2014);
- Pavement Life-cycle Assessment Tool for Environmental and Economic Effects (PaLATE) is an Excel-based tool developed by University of California, Berkeley in 2003. Cost, air pollutants and leaching outputs can be compared between different design, construction and maintenance options (Horvath et al. 2003).
- In 2005, an LCA model of road construction using bottom ash from municipal solid waste incinerator was developed by the Technical University of Denmark (DTU) (Birgisdóttir et al. 2006);
- In 2005–2007, Newcastle University developed an LCA model for UK asphalt pavements, with an extended system boundary that considered the traffic emissions incurred by road maintenance works (Huang et al. 2009b);
- In 2007, the Portland Cement Association published the LCI of cement and three concrete products: ready mixed, precast and concrete masonry (Marceau et al. 2007), and
- Commercial LCA software, such as GaBi and SimaPro, are also available with built-in sublicensed databases.

There are important findings from previous LCA studies, which can be taken as a starting point for further applying LCA to the road pavement. Nevertheless, simply applying one of those LCA models to a road project is at risk of generalizing findings that apply only to the methodological choices made by the model, or using outdated data or data not suitable to the project. For example, Huang outlined the problems of using pre-2007 road LCA models/tools to the UK road sector (Huang 2007). The barriers were grouped into five categories, see Table 1.5.

**Table 1.5** Limitations of some LCA resources to the UK road sector (Huang 2007)

Model/database	Sector	Origin	Year of release	Recycled material	Accessibility	Limitation <sup>a</sup>
BEES	Construction	NIST, USA	Current version: 4.0		Free	I, II
Boustead	Transport	Boustead Consulting Ltd, UK	Current version: 5.0		Commercial	I
BRE environmental profiles	Construction	BRE, UK	Data updated to: 2004		Free	I
LCI of asphalt pavements	Asphalt pavements	IVL, Sweden	Draft 3: 2005	RAP	EAPA internal use	II, V, VI
LCI of road	Road	VTT, Finland	2001	BFS, CFA	No access by public	II, IV, V, VI
PaLATE	Pavements	UC Berkeley, USA	Unknown	Unknown	No access by public	II, VI
Road-RES	Road	DTU, Denmark	2005	IBA	PhD thesis at DTU	II, IV, V

<sup>a</sup> Limitation codes refer to the texts above

### I. Relevance

- Low relevance to the road and asphalt industry, such as the BEES model, and
- Data from non-UK sources may not represent the UK's industry average. This is particularly a concern when applying the model to real case studies.

### II. Adaptability

- Some data are now old, or the underlying assumptions and calculation methods unknown, such as PaLATE, and
- Some data are for a fixed material recipe, haulage distance, production process or machinery that cannot be generalized for use in other studies.

### III. Compliance

- Model or database developed before the ISO 14040 was issued (in 1997) and revised (in 2006) may not fully comply with it. (Some more recent studies also do not comply, especially in terms of transparency of approach and assumptions.)

### IV. Scope

- Models largely focused on one or a few environmental impacts, such as energy and air emissions in VTT's model, and leaching in DTU's model, and
- The limited inclusion of recycled materials, such as recycled asphalt pavement (RAP) in the IVL model, municipal solid waste incinerator (MSWI) bottom ash in DTU's model.

### V. Availability

- Practical models are not accessible, due to commercial restriction.

## ***1.2.2 A Review of LCA Resources***

A number of tools are available to undertake a LCA study for road pavement. Some conduct a full LCA study (Sect. 1.2.2.1–1.2.2.4); others focus on the carbon footprint of road projects (Sect. 1.2.2.5–1.2.2.7). These resources are of varied transparency, ease of use and license requirements. Some are presented below with a brief discussion on the strength/weakness and applicability to roads.

### **1.2.2.1 SimaPro and GaBi**

The two commonly used commercial LCA software are SimaPro and GaBi. SimaPro uses a 'tree' to illustrate the structure of the model (Fig. 1.6a). GaBi allows user to build 'plans' (process groups) where they can visually see the flows from



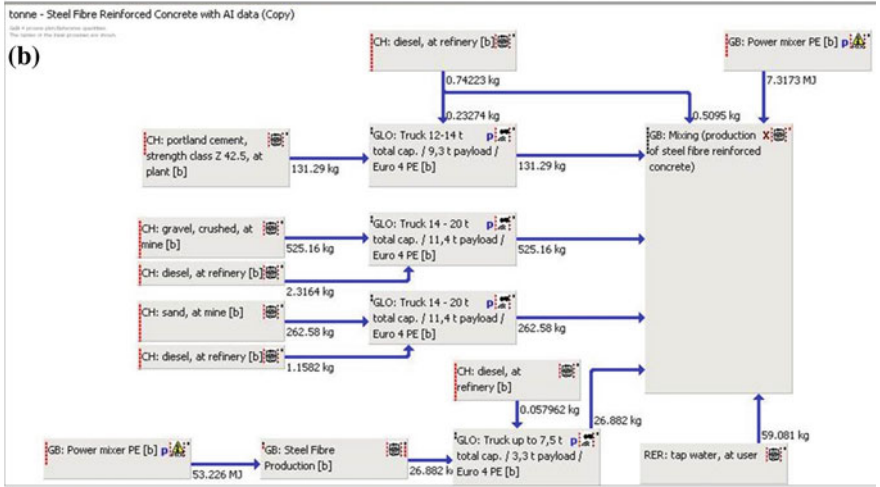
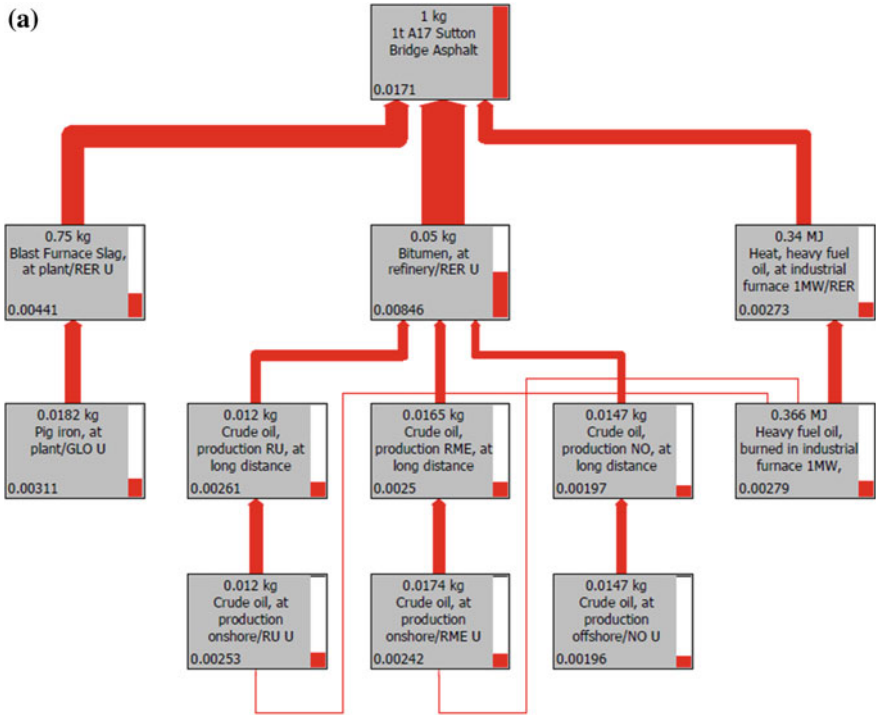

Fig. 1.6 a SimaPro. b GaBi

one process to another (Fig. 1.6b). There is similarity in the built-in databases and features between the two. Investment requirements are needed for license purchase, staff training and data renewal.

Some practical considerations in choosing which software to purchase:

- Built-in databases;
- Ease to learn and training offered by software provider;
- (For collaborative project use) which software other project partners are using;
- Open community with exchange of data between other software, e.g. tools in MS Excel, and
- The output format.

### 1.2.2.2 Portland Cement Association (Cement)

The report by the Portland Cement Association (Marceau et al. 2007) is the second update of *Environmental Life Cycle Inventory of Portland Cement Concrete*, originally published in 2000 and updated in 2002. The report presents the results of LCI analysis of three concrete products: ready mixed concrete, concrete masonry, and precast concrete. The system boundary, which defines the scope of the LCI, includes cement and slag cement manufacture, aggregate production, transportation of fuels, cement and aggregate to the concrete plant, and concrete plant operations. Data on fuels and electricity use at concrete plant are from confidential life cycle inventory surveys of concrete plants conducted in 2006. The report presents fuels and electricity use and emissions to air (carbon dioxide (CO<sub>2</sub>), carbon monoxide (CO), methane (CH<sub>4</sub>), nitrogen oxides (NO<sub>x</sub>), particulate matter (PM), sulphur dioxide (SO<sub>2</sub>), and volatile organic compounds (VOCs)), land and water. There are differences in the LCI figures between current and previous versions, due to newer plants with higher energy efficiency replacing older ones, revised measurement method and more accurate data (particularly for concrete plants and aggregate production).

### 1.2.2.3 Eurobitume (Bitumen)

In 2009 Eurobitume decided to update and enhance the bitumen LCI database originally published in 1999. The new study takes a cradle-to-gate system boundary. It covers the following processes. Some inventories take into account the construction of production facilities (infrastructure).

- Extraction of crude oil;
- Transport to Europe including pipeline and ship transport;
- Manufacturing of bitumen in a complex refinery, and
- Hot storage of the product.

The study (Eurobitume 2011) covers paving grade bitumen to the European bitumen standard EN 12591. The main bitumen production route is straight-run distillation (atmospheric distillation + vacuum distillation). In addition to bitumen, LCIs for Polymer Modified Bitumen (PMB) with 3.5 % polymer and bitumen

emulsion with 65 % bitumen were calculated. The report is based upon the most recent information available from the crude oil production and refining industry, European collated submissions and data collected by industry. The allocation between bitumen and other co-products made from crude oil is based on mass at the crude oil extraction and the transport stages. At the refining stage, the allocation is based on economic values. The LCI is shown as a list of emissions and resource used (see Table 1.2), and is available as an Excel file which enables it to be integrated into commercial LCA software. The report has been peer reviewed by an independent expert.

### 1.2.2.4 Athena Impact Estimator for Highways

The Athena team, with support from Environment Canada, the Cement Association of Canada and transportation engineers, has developed a LCA tool for road transport engineers, which is now freely available (Athena 2014). The *Athena Impact Estimator for Highways* provides LCA results including the materials manufacturing, roadway construction, vehicle use, and rehabilitation stages. It allows custom roadway design, or users can draw from a library of 50 existing designs (an example is seen in Fig. 1.7). The software sources data on materials from the Athena Institute and literature, and allows for comparison of alternative design options.

The tool supports nine regional locations in Canada and can model a host of road types from streets to multi-lane highways. Material data represent national or industry averages for the extraction, processing and manufacturing. Regional energy grids and transportation distances are applied to generate the regional average data. Roadway lifespan is variable and dictates rehabilitation schemes such as scheduled resurfacing. The inventory results comprise the energy and raw material flows, plus emissions to air, water and land. Results are reported on a gross roadway surface area (m<sup>2</sup>) basis. The tool follows the environmental impact assessment measures consistent with the US EPA’s Tool for the Reduction and Assessment of Chemical and Other Environmental Impacts (TRACI) methodology (EPA 2014b). Demolition and disposal are excluded, on the assumption that highways typically have long service lives.

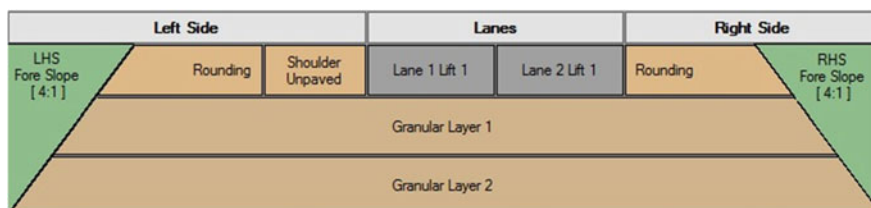

Fig. 1.7 Road structure for modelling in Athena highway impact factor (Athena 2014)

Moreover, the tool has an expanded system boundary modelling Pavement Vehicle Interactions (PVI), so designers can consider roadway roughness and pavement deflection in order to predict the fuel consumption by traffic (Athena 2014). Other studies have indicated that vehicle fuel consumption is largely determined by many factors other than pavement performance (Hammarstrom et al. 2009; Lepert and Brillat 2009), it will be interesting to see the results if some case studies carried out using this tool can be published in coming years.

### 1.2.2.5 PAS 2050

The UK publicly available specification PAS 2050 (BSI 2011) specifies requirements for assessing the life cycle GHG emissions of goods and services, and is finding wide use in the UK, Europe and elsewhere (Sinden 2009). Clearly steered towards the harmonization of measuring the carbon footprint of retail products, PAS 2050 includes a methodology that can also be used in other sectors, and some of the same methodological choices can be applied to conduct a full LCA. However, some methodological choices made by PAS 2050 give rise to questions of how and whether it is appropriate to apply them to road pavement LCAs:

- Capital goods and employee transport are excluded, but some administration activities (e.g. operation of premises) are included;
- Where necessary, allocation among co-products is made on a physical (e.g. mass) or economic basis; allocation for end-of-life (EOL) recycling (PAS 2050 Annex D) follows either the ‘recycled content’ or ‘approximation’ approach that gives 100 % benefits of recycling to one party in the supply chain;
- The 1 % ‘materiality threshold’ as a cut-off criterion needs discretionary screening prior to any analysis;
- For ‘business-to-business’ communication, the cradle-to-gate boundary is unable to account for the functionality of the product, such as the influence of pavement performance on vehicle fuel efficiency, or the cyclic rehabilitation work causing congestion and demanding future resources, and
- GHG emissions due to land use change are included but limited to the scenarios of change from forest/grassland to crop land (PAS 2050 Annex C).

### 1.2.2.6 asPECT

In 2011, the UK Transport Research Laboratory, in collaboration with the Highways Agency, Mineral Products Association and Refined Bitumen Association, published the latest version of the asphalt Pavement Embodied Carbon Tool (asPECT). This UK-based tool (TRL 2011), see Fig. 1.8, has been developed to produce PAS 2050-compliant cradle-to-grave carbon footprint reports for asphalt, except that for allocation, asPECT splits the benefits of recycling 60 %:40 % between the EOL user and original producer of recycled asphalt. The purpose

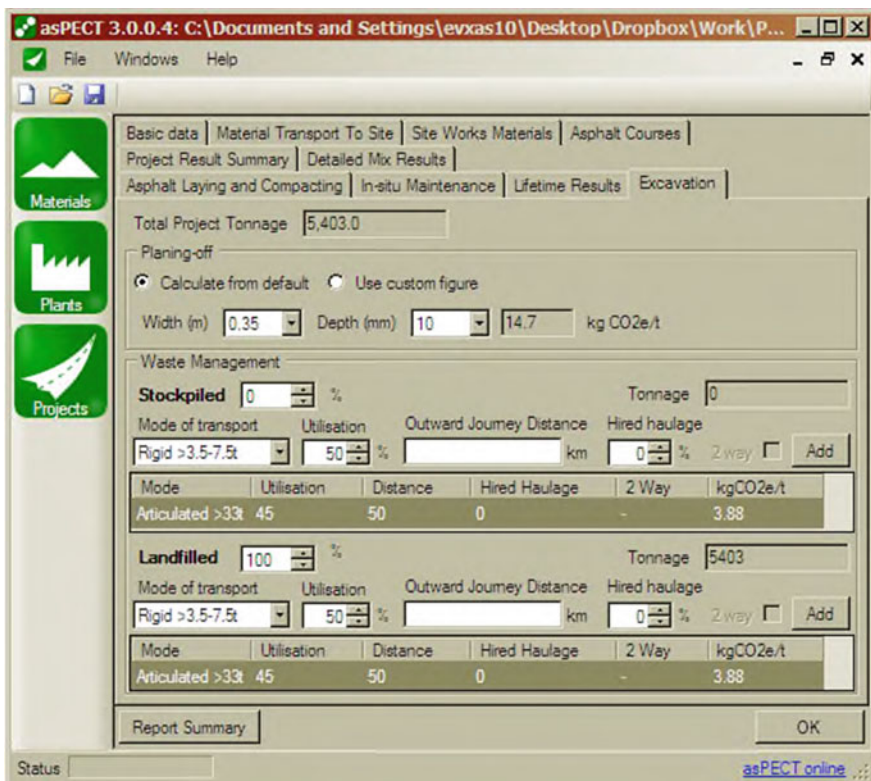

Fig. 1.8 asPeCT screenshot (TRL 2011)

according to the guidelines, is to encourage both parties in the product life cycle and meanwhile give more credit to the user in order to encourage industry recycling (Wayman et al. 2011).

### 1.2.2.7 CHANGER

CHANGER, the Calculator for Harmonised Assessment and Normalisation of Greenhouse-gas Emissions for Roads, was developed by the International Road Federation (IRF). The model is being developed with a view to elaborate an IRF standard and certification (Zammataro et al. 2011). The tool development, in partnership with contractors and design consultant, undertakes an iterative approach that includes data sourcing, initial analysis, feedback to data provider, and revisits the calculation, in accordance with ISO 14044 (BSI 2006c). The tool takes into account a range of emission sources during project life, and analyses at a project level to benchmark the carbon footprint per km of road construction. CHANGER

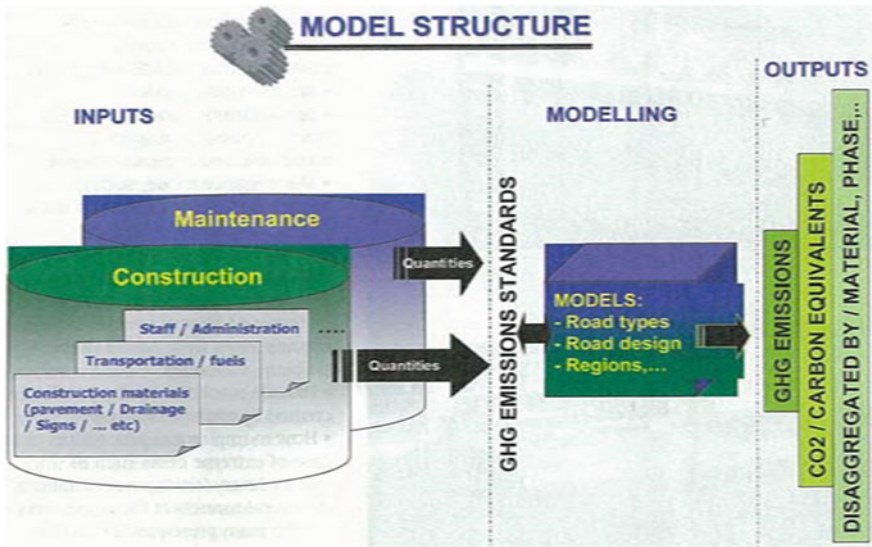

Fig. 1.9 Model structure of CHANGER (IRF 2007)

generates reports, either aggregated (total) or disaggregated (inherent to one or more steps of the process), that can be exported to Excel, Word, PDF and HTML. The datasets and the calculation have been validated by independent LCA experts (Bueche and Dumont 2009).

CHANGER adopts a typical process-based modelling approach (Fig. 1.9). The calculation model is based on a set of equations that enable accurate estimation of overall GHG emissions (outputs) generated by each identified and quantified source (inputs) (IRF 2007). Data will be sourced for the preconstruction (e.g. site clearance, cut and fill, deforestation), materials production, transport, and onsite construction activities. The current version of the model does not include maintenance activities, provision and powering of street lighting, road signs and barriers, and impact associated with traffic using the road. The model does not account for the loss of CO<sub>2</sub> absorption by removal of trees or other land use change. Huang et al. (2012) conducted case studies of using CHANGER to measure the carbon footprint of several major road projects in the UK, India and United Arab Emirates and recommended further development of the tool.

### 1.2.3 Summary of Current and Past Practice

The LCA of road pavements has been developing for more than 15 years. The framework of applying LCA to pavement was established in the late 1990s (Hakkinen and Makela 1996; Stripple 2001). The life cycle inventory of pavement materials has

been researched thoroughly by material associations (Eurobitume 2011; Marceau et al. 2007), comparing to early studies of just energy consumption (Zapata and Gambatese 2005). It is a challenge to use the findings, such as the LCI of cement or bitumen, in a LCA study of road project and maintain comparable levels of accuracy and industrial consensus. The early work has been strengthened by including recycled and secondary materials (Birgisdóttir et al. 2006; Huang et al. 2009b; Mroueh et al. 2001), a growing practice in response to stakeholders' call for sustainable construction. More recent LCA research is focused on the methodological choices, allocation for instance (Chen et al. 2010; Sayagh et al. 2010; Huang et al. 2013), and comparison of design options (Cross et al. 2011; Santero et al. 2011a).

Commercial LCA software will help the modelling with data support and presentation. Use of these tools will improve efficiency of modelling, and provides a means of communication between LCA practitioners. However, methodological choices made in LCA studies can change the conclusions, and thus need to be addressed in a coordinated way. Standard (sets of) rules, known as product category rules, need to be developed and accepted by the sector; see EN 15804 (BSI 2012). When time and budget allows, it is always advisable to cross-check the results from different tools, in order to test and calibrate the tools, and verify any benchmark figures for a typical construction in a specific country.

## 1.3 A Framework for Road Pavement LCA

### 1.3.1 System Boundary and Life Cycle Stages

Pavement life, typically greater than 20 years, is a function of design, materials durability, traffic and the environment. It may be defined as the time until structural rehabilitation is required but even then, not all pavement layers are replaced and so, the lifetime of a LCA study is a difficult decision. The difficulty in defining or predicting pavement life is compounded by the potential use of recycling, new materials (e.g. warm mix asphalt) and new construction techniques (e.g. use of geotextile), which has effectively confined the boundary of many LCA studies to cradle-to-gate (Hammond and Jones 2011), or to the point of first construction, cradle-to-laid (Wayman et al. 2011). Studies with long life cycles would benefit from dynamic LCA studies (Sect. 1.1.4.3).

In addition, it has been noted from the beginning of road LCA that traffic emissions can account for the majority of emissions from a road (Piantanakulchai et al. 1999; The Highways Agency 2003). The ratio has been quantified by recent European research to be in the range of 93–99 % (ECRPD 2010) or even higher (Milachowski et al. 2011). Because vehicle fuel consumption is affected by many factors other than pavement performance (Hammarstrom et al. 2009; Lepert and Brilllet 2009), traffic emissions are typically excluded from pavement LCAs, even though pavement evenness and layer stiffness can have an influence (Wang et al. 2012). There is a



further limitation, in that pavement rehabilitation and maintenance lead to not only additional construction activities, but traffic queuing or diversion at road works. Few studies have investigated the additional traffic emissions that can result, and have been constrained to simplified traffic modelling (Huang et al. 2009b) or hypothetical scenarios (Santero et al. 2011a), with no validation or sensitivity check on the impact of traffic flow or traffic management options, on the results.

These problems are related to system boundary settings. A cradle-to-gate scope can avoid the uncertainty associated with pavement use, at the expense of not taking into account any durability or recyclability. Traffic emissions under the free flow state can be estimated by multiplying the length of journey with average emission factors (e.g. kg CO<sub>2</sub> per vehicle kilometre), typically tied to the age, engine size and fuel type of the vehicles (DEFRA 2011), or they can be derived from commercial databases (e.g. Ecoinvent) (Milachowski et al. 2011). Managed traffic flows are better modelled in a micro-simulation tool coupled with an instantaneous emissions model, because this type of tool is able to relate the emission rates precisely to vehicle operation (e.g. driving pattern, speed profile) during a series of short time steps (Barlow et al. 2007), representing restricted flow or congestion that may be caused by road works. As a result, there is a need to expand the boundary of road LCA to fill this knowledge gap.

The purpose of providing road pavements is for traffic use and the geometry and engineering performance of the pavement does affect traffic fuel consumption. However, other factors impact on the fuel efficiency of the vehicles; many are outside the scope of pavement engineering, e.g. tire characteristics, vehicle aerodynamics, fuel type etc. Some research on the effect of pavement performance on vehicle fuel efficiency has concluded that quantifying these impacts is not straightforward (Hammarstrom et al. 2009). Due to the magnitude of the impacts, this remains an important challenge but could have a significant impact on research and industry practice.

In setting the boundary of a road pavement LCA, it is important to consider the goal of the study, including the stage of a project lifecycle at which it is being undertaken and for which its results may be used in making decisions. For instance, an LCA study for planning a new road might include different geometric options or junctions (Hughes et al. 2011). If the results were to be used to help make decisions about these options, then traffic emissions could be a very important part of the study; whereas predicted construction and maintenance works might only be included with much less rigor, due to uncertainties in future requirements. A study comparing different maintenance options for an existing pavement might only include the impact of maintenance works on traffic emissions and concentrate more on construction activities and durability of treatments, alongside future predicted maintenance requirements. A set of sustainability assessment tools, including carbon footprint calculators, reflecting these different emphases have recently been released by the Conference of European Directors of Roads (CEDR) (ERA 2014).



### ***1.3.2 Non-energy Related Emissions***

Most LCA studies include energy (and fuel) inputs in their inventories. In general, energy related emissions can be calculated with relatively high accuracy, by tracing the consumption back to the generation process (e.g. electricity from power station) and using standard national emissions factors. Non-energy related emissions (e.g. emissions from hot asphalt) however, are difficult to measure and quantify. For instance, fumes and dust are major concerns in environmental regulation of an asphalt plant (Read and Whiteoak 2003), yet they are generally not included in the life cycle inventory of the production of hot mix asphalt because relevant data are not available. However, the omission of non-energy use CO<sub>2</sub> emissions could lead to substantial over/under presentation of the inventory results (Masanet and Sathaye 2009).

The use of Reclaimed Asphalt Pavement (RAP) in pavement construction can conserve natural resources and reduce impacts (e.g. CO<sub>2</sub> emissions) on the environment. However, old pavements exposed to vehicle exhaust, tire and brake wear, and fuel spillage over many years, potentially contain hazardous substances. The contamination rate can be higher in urban areas where a large part of RAP derives from utility works, and the problems with contaminated RAP can be greater, for instance in Eastern Europe where the use of tar binder continued into the 1990s. Uncertainties regarding the performance of RAP (environmental, mechanical, etc.) currently results in a substantial part of it being mixed into unbound granular layers or other low-grade applications. In order to use RAP in high value applications such as surface course asphalt, one must be able to scientifically quantify the health and environmental risks associated with such applications. Re-Road, a European FP7 project, developed tools that can be used to assess these risks. The assessment encompasses the whole life cycle of RAP such as production (e.g. milling), processing and handling (e.g. crushing, screening and storage), mixing, use in pavement, and recycling. Risk Assessment and LCA are used to understand the potential health and environmental impacts of the processes involved. The project has investigated the leaching and fuming aspects of using asphalt planings in roads (Wayman et al. 2012). Once an inventory of emissions from processing and using RAP in road pavement is established, exposure assessment can be carried out for risk assessment, and sensitivity analysis undertaken to see how these impacts would vary across different stages in the lifecycle.

### ***1.3.3 Data Sources***

For a cradle-to-laid LCA of a road pavement, the environmental impacts of road projects may come mainly from three sources:

1. Materials' embodied impacts are determined by the type and quantity, including the manufacture and upstream processes, commonly referred to as 'cradle-to-gate' where the inventory data from previous LCA research on materials, such

as Portland Cement Association (Marceau et al. 2007) or Eurobitume (Eurobitume 2011) can be used. This unit inventory is then multiplied by the quantity of each type of material.

2. Impacts (e.g. fossil fuel consumption, emissions) from transport vehicles that bring raw materials and products to plant/site or unserviceable materials to a place of disposal (e.g. recycling, stockpile, landfill). UK Department for Environment, Food and Rural Affairs (Defra) has standard emission factors (limited to CO<sub>2</sub>, CH<sub>4</sub> and N<sub>2</sub>O) for an array of payloads and fuel types (DEFRA 2011), which is multiplied by tonnage and distance. Alternatively, emission limits on different combustion processes are specified in the EMEP/CORINAIR Emission Inventory Guidebook (EMEP/EEA 2013). These are however the ‘worst case scenario’ and eliminate the difference in practice by contractors.
3. Impacts from construction activities (e.g. excavation, paving, rolling) are calculated either for each individual process (Stripple 2001) or for a paving assembly as a whole (ECRPD 2010), which is then multiplied by dimension/quantity of the work on site. Emission limits of construction equipment can also be found in the CORINAIR emission guidebook.

Primary data should be used where possible but most studies will rely in part on secondary data. Data from different sources will be different in terms of quality, validity and methodology. ISO 14040 has definitions regarding the data quality, namely the temporal (time-related, age of data and the minimum length of time over which data are collected) and spatial (geographical area from which data are collected) characteristics. Due to the holistic nature of LCA, data will almost certainly be sourced from different places. Sensitivity analysis of data from different sources can be beneficial in understanding where efforts should be made to source high quality data and the confidence that it is possible to have in the results of the LCA study. Innovative asphalt materials and laying techniques continue to emerge, which calls for an expanding database for LCA practitioners that can accommodate new approaches. Where the required data for a unit process come from more than one source, the compatibility (date, boundary, underlying assumptions, etc.) of the data needs to be studied. Data acquisition for LCA can be hindered by commercial restriction on some proprietary data.

### *1.3.4 Allocation, Among Co-products*

Environmental burdens of petroleum products are advised by Wang et al. (2004) to be allocated at the ‘lowest possible sub-process level’ within a refinery. This involves the attribution of energy from different refinery units to intermediate product streams to develop a process-based allocation. This approach is considered by Keesom et al. (2009) to be vulnerable to lack of data on the yields and energy use at the fundamental processing level in the refinery, and the connection between

process units. Eurobitume's LCI uses two methods of allocation among petroleum products including bitumen (Eurobitume 2011):

- At crude oil extraction and transport stage, where the products are treated as raw materials, the allocation is based on mass, and
- At the refining stage, the allocation is based on economic value, i.e. market price of the outputs factored by their physical yields, partly because these outputs (diesel, bitumen, wax, etc.) are going to different uses.

A sensitivity check carried out by Eurobitume indicated that the CO<sub>2</sub> emissions of bitumen would be 23 % higher if allocation was 100 % by mass, or 45 % lower if 100 % by price (Eurobitume 2011). The Eurobitume inventory also provides data for bitumen production taking into account capital goods (infrastructure required to produce, transport and refine crude oil). Data in some commercial LCA databases also follow this approach, such as Ecoinvent that includes the provision of roads and vehicles in the inventory of transport services by trucks (Spielmann and Scholz 2005).

A paper looking at the partial replacement of cement with Ground Granulated Blast Furnace Slag (GGBS) or coal fly ash also indicated a high material embodied carbon due to mass allocation (Chen et al. 2010). Similarly, granulated Blast Furnace Slag (BFS) used as aggregate in the base and sub-base of a road with 30-year design life increased the project CO<sub>2</sub>-eq. by some 60 %, when the burdens of steel making allocated to BFS changed from 0 (treated as waste) to 20 % (allocation by mass) (Sayagh et al. 2010).

Recycling is topical to pavement engineers. Apart from resource efficiency, some products of high embodied CO<sub>2</sub> can be partially replaced by outputs from other industries that are often otherwise treated as waste. Huang et al. (2013) carried out a sensitivity analysis of the effect of allocation method on LCA results. Changing from industry chosen allocation methods (e.g. Eurobitume, asPECT) to 100 % mass or economic allocation leads to changes in results, which vary across impact categories. Allocation based on mass is found to consistently lead to the highest figures in all impact categories, believed to be typical for construction materials. While there is no right or wrong method of allocation amongst co-products, it is important to be transparent and consistent in the use of data, with clearly stated allocation methods, particularly in comparative LCA.

### ***1.3.5 Allocation, at End-of-Life Recycling***

Most pavement materials are recyclable at the end of design life. Allocation rules for EOL recycling can be defined based on whether the inherent properties of the material change as a result of recycling. Complex products such as buildings and cars have different disposal scenarios for components and thus recycling is product (assembly), rather than material, based; allocation at EOL recycling in this case usually involves both the open-loop (where materials are recycled into a different

product) and closed-loop (where materials are recycled into a similar product) scenarios, and is based on physical as well as economic relationships (Vogtländer et al. 2001). Products of less heterogeneous components such as road pavement materials, mostly deal only with material-based, closed-loop recycling.

The route taken by studies of recycled metals is worth referring to. For instance, the steel industry uses the ‘substitution’ method, which requires an assumption of EOL recovery rate and the ratio of steel to scrap yield (World\_Steel\_Association 2008), as shown by Eq. (1.1a). In this method, original production of the recyclable steel is given the full benefits of recycling at EOL. The aluminium industry bases its allocation on an economic aspect, such as the price elasticity for primary and secondary aluminium. Frees (2008) found that some 60–70 % of the demand for aluminium is made from primary source, and the avoided production by recycling will hence mainly be of primary aluminium. This ‘scrap’ deficit is similarly seen by the asphalt industry in Europe, where available reclaimed asphalt makes in general less than 35 % of a country’s annual production (EAPA 2009).

$$\text{LCI of steel production} = \text{LCI}_{\text{pr}} - R \times Y \times (\text{LCI}_{\text{pr}} - \text{LCI}_{\text{re}}) \quad (1.1a)$$

where<sup>1</sup>:

- R = recycling rate of the steel product;
- Y = process yield of the EAF (i.e. >1 kg scrap is required to produce 1 kg steel);
- $\text{LCI}_{\text{pr}}$  = cradle-to-gate LCI for 100 % primary metal production. This is a theoretical value for steel made in the BF/BOF, assuming 0 % scrap input, and
- $\text{LCI}_{\text{re}}$  = cradle-to-gate LCI for 100 % secondary metal production from scrap in the EAF (assuming scrap = 100 %).

Equation (1.1a) is equivalent to the ‘approximation’ method prescribed by PAS 2050 (Annex D), as shown by Eq. (1.1b) ( $R_2 = R$ ,  $E_V = \text{LCI}_{\text{pr}}$ ,  $E_R = \text{LCI}_{\text{re}}$ ) except that: (1) ‘Y’ is equal to 1 in PAS 2050, and (2) PAS 2050 includes the emissions of disposing of the material unable to be recycled. This rate ( $1 - R_2$ ) is considered low in general by the steel industry (World\_Steel\_Association 2008).

$$\text{Emissions/unit} = (1 - R_2) \times E_V + R_2 \times E_R + (1 - R_2) \times E_D \quad (1.1b)$$

It is noted, however, that unlike steel or aluminium, most bound pavement materials do not maintain the same inherent properties when recycled. LCA of road pavements thus tend to take the ‘cutoff’ method: each product is assigned only the burdens directly associated with it; in other words, all benefits of recycling are given downstream to using the recycled material, with no indication of the actual rate of, or potential for, recycling. This approach is also known as the ‘recycled

---

<sup>1</sup> EAF: electric arc furnace; BF: blast furnace; BOF: basic oxygen furnace.

content' method (Hammond and Jones 2011), prescribed by PAS 2050 as in Eq. (1.2) with parameters denoted the same as in Eq. (1.1b).

$$\text{Emissions /unit} = (1 - R_1) \times E_V + (R_1 \times E_R) + (1 - R_2) \times E_D \quad (1.2)$$

where:

- $R_1$  = proportion of recycled material input;
- $R_2$  = proportion of material in the product that is recycled at end-of-life;
- $E_R$  = emissions arising from recycled material input, per unit of material;
- $E_V$  = emissions arising from virgin material input, per unit of material, and
- $E_D$  = emissions arising from disposal of waste material, per unit of material.

LCA in its development has produced an array of allocation methods. They were firstly stated by Ekvall and Tillman (1997) and evolved by Nicholson et al. (2009) into five main categories including the 'cutoff' and 'substitution' described above, and three other routes with their rationale listed below. Frischknecht (2010) indicated that the 'cutoff' method presents lower uncertainty associated with EOL use. For that reason, it may be endorsed by highway authorities, whilst the 'avoided burden' (equivalent to 'substitution') method emphasises a short term perspective that is likely to be supported by material manufacturers because there is an immediate benefit. The 'closed loop' and 'loss of quality' methods require knowledge of the fate of the material that is usually beyond the analysis period of a road pavement LCA, and thus have not seen any use to date (Huang et al. 2013).

1. 50/50 method: supply and demand are both necessary to enable recycling. Half the benefits of recycling are hence allocated to using recycled material, and the other half to producing the recyclable material.
2. Closed-loop method: assumes that each product is equally responsible for the burdens associated with the entire product life cycle. The impacts are thus apportioned equally among products in the life cycle by the number of times recycling occurs.
3. Loss of quality method: similar to the 'closed loop' method except that each product is assigned the burdens based on its value in the product life cycle (weighting factor). The rationale is that each time recycling occurs, the material suffers a loss in quality which necessitates a certain level of upgrading to restore its function. Material pricing data are commonly used as a proxy for quality.

### ***1.3.6 Summary of Challenges and Way Forward***

In summary, the main challenges of applying LCA to pavement construction practice include the following aspects, which also highlight areas for further work:

- Include the non-energy (process) related emissions in the modelling;
- Establish inventory data on secondary materials, investigate the appropriate allocation methods;
- Predict the life expectancy, and the end-of-life disposal, of pavement layers made using recycled and other innovative materials;
- Include the effect of road maintenance works on traffic flow and the additional fuel use and emissions that result, helped by traffic modelling, and
- Explore the relations between pavement condition and vehicle fuel consumption.

Sensitivity analysis helps in understanding the impact of the methodological choices, e.g. allocation method, on the LCA results. A case study by Huang et al. (2013) gives some examples of how much road pavement LCA results can change based on the choice of allocation method. Some design and construction options can also be modelled in LCA to test sensitivity. For instance, the use of preventative maintenance, such as surface dressing/thin surfacing overlay to reduce/delay the more resource-demanding rehabilitation, and the traffic management options in the course of road maintenance. Some of these elements have been shown potentially to have a significant effect on the overall environmental impacts of pavements (Santero et al. 2011b). To answer these questions fully is likely to steer a pavement LCA in a project-specific direction, meaning that data and conclusions may not be generalised. As a result, different functional units may need to be defined in the LCA model, to deal with different construction, condition, climate, location and traffic. The results of these studies can then be used in generating sector-specific product category rules (including the use phase) that are required as a step towards comparability and transparency in road pavement LCA.

A case study by Huang et al. (2009a) confirms findings from previous work, that the additional traffic emissions due to road rehabilitation are significant but the quantity varies between the pollutants (e.g. CO, NO<sub>x</sub>, particulates). It also demonstrates the feasibility of using results from LCA and traffic simulation to measure and compare the key environmental impacts from a road during its life time. It gives highway authorities an objective method for quantifying the environmental impacts of road maintenance works, including effective traffic management (lane closure, traffic diversion) and phasing of the roadwork into off-peak hours (night shifts). The method can also be used to compare the advantages of using recycled materials, with the possible disadvantages of such work taking longer. More case studies of this type will help to elucidate the best approaches to take in future pavement LCA studies. The rules required to gain comparability and transparency will need to be agreed (or imposed by clients) at sector level and case studies, including sensitivity analysis, will be important in providing the evidence necessary in making methodological choices.

Despite the current climate change agenda and the fact that many LCA tools give CO<sub>2</sub> predominant attention, global warming is not the only environmental problem we face. Other impacts associated with a road (e.g. leaching, fuming, and noise) especially when recycled materials are increasingly used, should not be traded off for GHGs. The EU Framework Program 7 project ReRoad has made efforts in quantifying the non-energy related emissions from using recycled materials

(Wayman et al. 2012). Before the results can be applied widely and influence decision making, limitations will need to be addressed (e.g. no sensitivity analysis to time or location) along with ways of integrating with other design and sustainability tools/methods, such as risk assessment and whole life cost analysis. Companies aiming for environmental labelling need to ensure that their pursuit of ‘green’ construction is not simply based on a single aspect such as CO<sub>2</sub> reduction.

### ***1.3.7 A Checklist for Conducting and Assessing Pavement LCA***

#### **1. Set a Goal for the study, which could be;**

- ‘Green’ product development e.g. to generate a hotspot analysis of where major environmental impacts exist (perhaps cement or asphalt production and the use of secondary materials).
- Decision making e.g. a comparative study to help in product selection or rehabilitation strategy.
- Benchmarking e.g. selecting or reporting against performance indicators.

In each case it is important to decide who the audience for the study is. This will be necessary to decide how the results will be reported and what level of review is required. Published studies and those for third party decision makers will require a high degree of transparency.

#### **2. Set the study Scope;**

These decisions should become clear once the Goal has been carefully defined.

- Define the product system(s); for instance is the pavement foundation included; is it important to include traffic emissions?
- Define the environmental impacts to be considered, being careful to consider which are the most important and could limitation (e.g. a carbon footprint) lead to decisions that risk other impacts increasing?
- Consider which life cycle stages to include (cradle-to-gate, -laid or -grave) and consider which members of the supply chain will be consulted (material suppliers, paving contractors, highway authorities, vehicle manufacturers etc.).
- Consider if a static or dynamic study will be required.
- Consider if a process, input–output or hybrid study is required.

#### **3. Decide on the Functional Unit;**

Ensure that the FU meets the functional requirement that reflects the Goal and Scope of the study. This is particularly important for comparative studies. It might include:

- Pavement design thicknesses to meet the required traffic level of new or rehabilitated pavement.
- Lifetime often set as the pavement design life, or to include structural rehabilitation.

- Maintenance strategies, for instance those including different levels of preventative maintenance, or alternative maintenance treatments.
  - Recycling and EOL destinations of materials (recycled, re-used in a different function (e.g. unbound) or disposed to landfill).
4. Assess data quality while compiling the inventory. This can be done following guidelines in ISO 14040 series. Primary data should be used where time, cost and availability allow (including up and down the supply chain) but may make the study very specific to one situation if not representative. This should also include a comparison of secondary data sources. Using data which itself has been collected using different allocation, system boundary etc. may not be appropriate.
  5. During interpretation, sensitivity analysis of important assumptions, including:
    - Data quality, to decide which is most important to be of high quality.
    - Allocation method, to determine where it is important to gain consensus.
    - Traffic modelling technique, to decide what level of sophistication may be needed.
    - Durability of materials and pavement deterioration rates.
  6. Use a hot spot analysis, coupled with sensitivity analysis, to decide which are the most important data and lifecycle stages. Repeating studies a number of times, following hot spot analysis will help to refine the Goal, Scope and FU; these may need to change if the quality or availability of data will not allow them to be studied, or if initial results require a change in emphasis.
  7. For studies with long lifetimes, where sensitivity and/or hot spot analysis show that events in the future are important to the results, the degree of confidence in those results may need to be questioned. This may require sensitivity analysis of wider assumptions, where radical change may occur in the future, e.g. maintenance budgets, fuel/energy type (bio-diesel, renewables), traffic growth etc.
  8. Consider which tool to use, either an existing tool or creating a bespoke one. Whatever the decision, understand what the underlying assumptions are, including in-built datasets. Comparing results using more than one tool may give some interesting information on the importance of assumptions and on confidence in results.
  9. Where possible, publish case studies, containing not only results but considerations and decisions concerning the points above. Be transparent in the approaches taken. Try different approaches. Include the results of sensitivity analysis.
  10. Consider what the study approach and results can tell the wider pavement LCA community about the development of PCRs. These might define, data quality requirements, lifecycle stages, need for traffic modelling etc. The development of PCR(s), broadly accepted across the sector is possibly the most important step in allowing comparable and transparent pavement LCA results to be used in decision making.



## References

- Athena (2014). *The Athena impact estimator for highways* [Online]. Athena Sustainable Materials Institute. <http://www.athenasmi.org/our-software-data/impact-estimator-for-highways/>.
- Barlow, T. J., Boulter, P. G., & Mccrae, I. S. (2007). *Scoping study on the potential for instantaneous emission modelling: summary report*. Transport Research Laboratory.
- Baumann, H., & Tillman, A.-M. (2004). *The Hitch Hiker's guide to LCA: An orientation in life cycle assessment methodology and applications*. Lund: Studentlitteratur AB.
- Birgisdóttir, H., Pihl, K. A., Bhandar, G., Hauschild, M. Z., & Christensen, T. H. (2006). Environmental assessment of roads constructed with and without bottom ash from municipal solid waste incineration. *Transportation Research Part D: Transport and Environment*, 11, 358–368.
- BRE (2009). *BRE Environmental and sustainability standard—framework standard for the responsible sourcing of construction products*. UK: Building Research Establishment.
- BSI (2006a). Environmental labels and declarations: Type III Environmental declarations: Principles and procedures. *ISO EN BSI 14025*. British Standard Institution.
- BSI (2006b). Environmental management: Life cycle assessment: Principles and framework. *ISO EN BSI 14040*. British Standard Institution.
- BSI (2006c). Environmental management: Life cycle assessment: Requirements and guidelines. *ISO EN BSI 14044*. British Standard Institution.
- BSI (2011). PAS 2050: Specification for the assessment of the life cycle greenhouse gas emissions of goods and services. British Standards Institution.
- BSI (2012). Sustainability of construction works. Environmental product declarations. Core rules for the product category of construction products *BS EN 15804*. British Standard Institution.
- Bueche, N., & Dumont, A.-G. (2009). *IRF greenhouse gas calculator—analysis and validation*. Zurich: Traffic Facilities Laboratory, Swiss Federal Institute of Technology.
- CARBONTRUST (2006). Carbon footprints in the supply chain: The next step for business. *CTC 616*. London: The Carbon Trust.
- Chen, C., Habert, G., Bouzidi, Y., Jullien, A., & Ventura, A. (2010). LCA allocation procedure used as an incitative method for waste recycling: An application to mineral additions in concrete. *Resources, Conservation and Recycling*, 54, 1231–1240.
- Cross, S., Chesner, W., Justus, H., & Kearney, E. (2011). Life-cycle environmental analysis for evaluation of pavement rehabilitation options. *Transportation Research Record*, 2227, 43–52.
- DEFRA. (2011). *Guidelines to Defra/DECC's GHG conversion factors for company reporting: methodology Paper for emission factors*. Bristol: Department for Environment, Food and Rural Affairs.
- EAPA (2009). *Asphalt in figures 2009*. Brussels: European Asphalt Pavement Association.
- ECRPD (2010). *Energy conservation in road pavement design, maintenance and utilisation*. Grant Agreement: EIE/06/039/SI2.448265: Intelligent Energy—Europe.
- Ekvall, T., & Tillman, A.-M. (1997). Open-loop recycling: Criteria for allocation procedures. *The International Journal of Life Cycle Assessment*, 2, 155–162.
- EMEP/EEA (2013). *EMEP/EEA air pollutant emission inventory guidebook 2013: Technical guidance to prepare national emission inventories*. European Monitoring Evaluation Programme/European Environmental Agency.
- EPA (2014a). *LCA Resources* [Online]. United States Environmental Protection Agency. <http://www.epa.gov/nrmrl/std/lca/resources.html>.
- EPA (2014b). *Tool for the Reduction and Assessment of Chemical and Other Environmental Impacts (TRACI)* [Online]. United States Environmental Protection Agency. <http://www.epa.gov/nrmrl/std/traci/traci.html>.
- ERA (2014). *ERA-NET Road* [Online]. European Road Administration. <http://www.eranetroad.org/>.
- Eurobitume (1999). *Partial life cycle inventory or "eco-profile" for paving grade bitumen*. Brussels: European Bitumen Association.

- Eurobitume (2011). *Life cycle inventory: bitumen*. Brussels: The European Bitumen Association.
- Frees, N. (2008). Crediting aluminium recycling in LCA by demand or by disposal. *The International Journal of Life Cycle Assessment*, 13, 212–218.
- Frischknecht, R. (2010). LCI modelling approaches applied on recycling of materials in view of environmental sustainability, risk perception and eco-efficiency. *The International Journal of Life Cycle Assessment*, 15, 666–671.
- Guinee, J. B. (ed.) (2002). *Handbook on life cycle assessment—operational guide to the ISO standards*. Dordrecht: Kluwer Academic Publishers.
- Guo, M., & Murphy, R. J. (2012). LCA data quality: Sensitivity and uncertainty analysis. *Science of the Total Environment*, 435–436, 230–243.
- Hakkinen, T., & Makela, K. (1996). *Environmental adaptation of concrete—environmental impact of concrete and asphalt pavements*. Espoo: Technical Research Centre of Finland (VTT).
- Hammarstrom, U., Karlsson, R., & Sorensen, H. (2009). *Road surface effects on rolling resistance—coastdown measurements with uncertainty analysis in focus*. Deliverable D5(a) of the Energy Conservation in Road Pavement Design, Maintenance and Utilisation (ECRPD). Swedish National Road and Transport Research Institute (VTI).
- Hammond, G., & Jones, C. (2011). *Inventory of carbon and energy (ICE) version 2.0*. Bath: University of Bath.
- Highways Agency (2003). *Building better roads: Towards sustainable construction: The Highways Agency's contribution to sustainable development through the construction and maintenance of the strategic road network in England*.
- Horvath, A., Pacca, S., Masanet, E., & Canapa, R. (2003). *Consortium on green design and manufacturing—pavement life-cycle assessment tool for environmental and economic effects (PaLATE)* [Online]. <http://www.ce.berkeley.edu/~horvath/palate.html>.
- Huang, Y. (2007). Life cycle assessment of use of recycled materials in asphalt pavements. *PhD*, Newcastle University
- Huang, Y. (2010). Life cycle assessment in road construction. In *Sustainable measurement in road construction*. Loughborough, UK
- Huang, Y., Bird, R., & Bell, M. (2009a). A comparative study of the emissions by road maintenance works and the disrupted traffic using life cycle assessment and micro-simulation. *Transportation Research Part D: Transport and Environment*, 14, 197–204.
- Huang, Y., Bird, R., & Heidrich, O. (2009b). Development of a life cycle assessment tool for construction and maintenance of asphalt pavements. *Journal of Cleaner Production*, 17, 283–296.
- Huang, Y., Hakim, B., & Zammataro, S. (2012). Measuring the carbon footprint of road construction using CHANGER. *International Journal of Pavement Engineering*, 14, 590–600.
- Huang, Y., Spray, A., & Parry, T. (2013). Sensitivity analysis of methodological choices in road pavement LCA. *The International Journal of Life Cycle Assessment*, 18, 93–101.
- Hughes, L., Phear, A., Nicholson, D., Pantelidou, H., Soga, K., Guthrie, P., Kidd, A. & Fraser, N. (2011). Carbon dioxide from earthworks: a bottom-up approach. In *Proceedings of the ICE—Civil Engineering* [Online], (p. 164).
- ICE (2008). *CEEQUAL scheme description and assessment process handbook*. The Institution of Civil Engineers.
- ILCD (2010). *International reference life cycle data system: General guide for life cycle assessment—detailed guidance*. Luxembourg: European Commission—Joint Research Centre—Institute for Environment and Sustainability.
- Inamura, H., Piantanakulchai, M., & Takeyama, Y. (2000). A life cycle inventory analysis of carbon dioxide for a highway construction project using input-output scheme: A case study of the tohoku expressway construction works. In *8th International Conference on Input-Output Techniques*. Macerata, Italy.
- IPCC (2007). *Climate change 2007: The physical science basis*. Intergovernmental Panel on Climate Change.
- IRF (2007). Green path to climate neutral roads. In: *World highways November/December 2007*, (pp. 22–23). Alexandria: International Road Federation.

- Keesom, W., Unnasch, S., & MORETTA, J. (2009). *Life cycle assessment comparison of North American and imported crudes*. Jacob Consultancy Life Cycle Associates—prepared for Alberta Energy Research Institute—File no: AERI 1747.
- Kneifel, J., & Greig, A. L. (2014). *BEEES please questionnaire users guide*. Gaithersburg: National Institute of Standards and Technology.
- Lepert, P., & Brillet, F. (2009). The overall effects of road works on global warming gas emissions. *Transportation Research Part D: Transport and Environment, 14*, 576–584.
- Levasseur, A., Lesage, P., Margni, M., Deschênes, L., & Samson, R. (2010). Considering time in LCA: Dynamic LCA and its application to global warming impact assessments. *Environmental Science and Technology, 44*, 3169–3174.
- Marceau, M. L., Nisbet, M. A., & VanGeem, M. G. (2007). *Life cycle inventory of portland cement concrete*. PCA R&D Serial No. 3011. Portland Cement Association.
- Masanet, E., & Sathaye, J. (2009). Challenges and opportunities in accounting for non-energy use CO<sub>2</sub> emissions: an editorial comment. *Climatic Change, 95*, 395–403.
- Milachowski, C., Stengel, T., & Gehlen, C. (2011). *Life cycle assessment for road construction and use*. EUPAVE—European Concrete Paving Association.
- Mildenberger, U., & Khare, A. (2000). Planning for an environment-friendly car. *Technovation, 20*, 205–214.
- Mroueh, U.-M., Eskola, P., & Laine-Ylijoki, J. (2001). Life-cycle impacts of the use of industrial by-products in road and earth construction. *Waste Management, 21*, 271–277.
- Muench, S. T., Anderson, J. L., Hatfield, J. P., Koester, J. R., & Söderlund, M. (2011). *Greenroads Manual v1.5*. University of Washington & CH2MHill.
- Nicholson, A. L., Olivetti, E. A., Gregory, J. R., Field, F. R., & Kirchain, R. E. (2009) End-of-life LCA allocation methods: Open loop recycling impacts on robustness of material selection decisions. In *IEEE International Symposium on Sustainable Systems and Technology, 2009. ISSST '09* (pp. 1–6). May 18–20, 2009.
- Nicholson, I. (2010, February 02). The CEEQUAL assessment and award scheme. In *Sustainability measurement in road construction*. Loughborough: Loughborough University.
- Parry, A. R. (2005). A model set of asphalt sustainability indicators. *TRL Report 638*. Transport Research Laboratory.
- Peuportier, B. L. P. (2001). Life cycle assessment applied to the comparative evaluation of single family houses in the French context. *Energy and Buildings, 33*, 443–450.
- Piantanakulchai, M., Inamura, H., & Takeyama, Y. (1999). A life cycle inventory analysis of carbon-dioxide for a highway construction project using input–output scheme: A case study of the Tohoku expressway construction works. *Journal of Infrastructure Planning and Management of Japan Society of Civil Engineers, 16*, 411–418.
- Read, J., & Whiteoak, D. (2003). *The shell bitumen handbook* (5th ed.). London: Thomas Telford Publishing.
- Santero, N., Loijos, A., Akbarian, M., & Ochsendorf, J. (2011a). *Methods, impacts, and opportunities in the concrete pavement life cycle*. Massachusetts: Massachusetts Institute of Technology.
- Santero, N. J., Masanet, E., & Horvath, A. (2011b). Life-cycle assessment of pavements. Part I: Critical review. *Resources, Conservation and Recycling, 55*, 801–809.
- Sarbanes, P., & Oxley, M. (2002). The Sarbanes-Oxley Act. In: CONGRESS, T. U. S. (ed.).
- Sayagh, S., Ventura, A., Hoang, T., François, D., & Jullien, A. (2010). Sensitivity of the LCA allocation procedure for BFS recycled into pavement structures. *Resources, Conservation and Recycling, 54*, 348–358.
- Schenck, R. (2000). Using LCA for procurement decisions: A case study performed for the U.S. environmental protection agency. *Environmental Progress, 19*, 110–116.
- Sinden, G. (2009). The contribution of PAS 2050 to the evolution of international greenhouse gas emission standards. *The International Journal of Life Cycle Assessment, 14*, 195–203.
- Spielmann, M., & Scholz, R. (2005). Life cycle inventories of transport services: background data for freight transport (10 pp). *The International Journal of Life Cycle Assessment, 10*, 85–94.

- Stripple, H. (2000). Life cycle inventory of asphalt pavements. Gothenburg: Swedish Environmental Research Institute (IVL).
- Stripple, H. (2001). *Life cycle assessment of road—a pilot study for inventory analysis*. Gothenburg: Swedish Environmental Research Institute (IVL).
- TRL (2011). *Asphalt pavement embodied carbon tool* [Online]. Transport Research Laboratory. <http://www.sustainabilityofhighways.org.uk/>.
- Vogtländer, J., Brezet, H., & Hendriks, C. (2001). Allocation in recycling systems. *The International Journal of Life Cycle Assessment*, 6, 344–355.
- Wang, M., Lee, H., & Molburg, J. (2004). Allocation of energy use in petroleum refineries to petroleum products. *The International Journal of Life Cycle Assessment*, 9, 34–44.
- Wang, T., Lee, I.-S., Kendall, A., Harvey, J., Lee, E.-B., & Kim, C. (2012). Life cycle energy consumption and GHG emission from pavement rehabilitation with different rolling resistance. *Journal of Cleaner Production*, 33, 86–96.
- Wayman, M., Parry, T., Andersson-Sköld, Y., Bergman, R., Huang, Y., Raaberg, J., & Enell, A. (2012). Re-road—end-of-life strategies of asphalt pavements. Deliverable 3.4. Life cycle assessment of reclaimed asphalt. In: *A FP7 Collaborative Project Work programme: Sustainable Surface Transport: End of life strategies for vehicles/vessels and infrastructures*.
- Wayman, M., Schiavi-mellor, I., & Cordell, B. (2011). *Protocol for the calculation of whole life cycle greenhouse gas emissions generated by asphalt—part of the asphalt pavement embodied carbon tool (asPECT)*. Berkshire: Transport Research Laboratory.
- Wenzel, H. (2006). *An international review of life cycle comparison for key materials in the UK recycling sector*. Technical University of Denmark.
- Wiedmann, T. (2009). Editorial: Carbon footprint and input–output analysis—an introduction. *Economic Systems Research*, 21, 175–186.
- World\_Steel\_Association (2008). *Application of the worldsteel LCI data to recycling scenarios—worldsteel recycling methodology*.
- Young, S., Turnbull, S., & Russell, A. (2002). *Toward a sustainable cement industry (Substudy 6): What LCA can tell us about the cement industry*. World Business Council for Sustainable Development: Five Winds International
- Zammataro, S., Laych, K., Sheela, V., Rao, M. R., Huang, Y., & Hakim, B. (2011). Assessing greenhouse gas emissions in road construction: an example of calculation tool for road projects. In: *PIARC seminar on Reducing the Carbon Footprint in Road Construction*. New Delhi, India, February 17–19, 2011.
- Zapata, P., & Gambatese, J. A. (2005). Energy consumption of asphalt and reinforced concrete pavement materials and construction. *Journal of Infrastructure Systems*, 11, 9–20.

## Chapter 2

# Application of LCA Results to Network-Level Highway Pavement Management

John Harvey, Ting Wang and Jeremy Lea

**Abstract** Environmental life cycle assessment (LCA) is a method developed in the 1960s for identifying environmental objectives, defining the system to be analyzed, quantifying environmentally important inputs and outputs to the system over a life cycle, and assessing the impacts. The application of LCA to pavements is a relatively new development. Pavement management systems (PMS) have been developed and implemented since the 1970s to manage pavement network asset inventories, collect condition data, predict performance for various management decisions and report the results to support decision-making needed to meet performance and cost objectives. This chapter discusses the relationship between LCA and PMS and benefits of integrating LCA into PMS. An example is provided for the objective of reducing greenhouse gas emissions on a state highway network. Gaps in implementation are identified, and recommendations are made for future work.

---

J. Harvey (✉) · J. Lea

Department of Civil and Environmental Engineering, University of California Pavement Research Center, University of California, Davis, CA 95616, USA  
e-mail: jtharvey@ucdavis.edu

J. Lea

e-mail: jdlea@ucdavis.edu

T. Wang

Department of Civil and Environmental Engineering, AgileAssets Inc,  
3001 Bee Caves Rd Ste 200, Austin, TX 78746, USA  
e-mail: twang@agileassets.com

© Springer-Verlag Berlin Heidelberg 2014

K. Gopalakrishnan et al. (eds.), *Climate Change, Energy, Sustainability and Pavements*, Green Energy and Technology, DOI 10.1007/978-3-662-44719-2\_2

## 2.1 Framework, Objectives and Needs

### 2.1.1 *Background: Pavement Management Systems and Life Cycle Assessment*

#### 2.1.1.1 Pavement Management Systems

Pavements are a fundamental part of modern societies. Movement of goods and people, using vehicles that currently primarily burn fossil fuels, depends on networks of reliable highway pavements. The management of these networks to meet the objectives of a society within various constraints is an essential activity. Pavement management involves all the activities involved in planning, design, construction, maintenance and rehabilitation (M&R) for a network of roadways, in order to optimize the overall pavement conditions over the entire network, usually with constrained resources (Shahin 2005). Pavement management systems (PMS) have been developed and implemented since the 1970s to manage pavement network asset inventories, collect condition data, predict performance for various management decisions and report the results to support decision-making needed to meet performance and cost objectives. Since the 1980s, most road owning organizations in North America have moved towards performing this work through a PMS, and the use of asset management systems in general is increasingly required by law.

Pavement management systems and sustainability considerations are discussed in general in another Chapter of this book. The following introductory discussion of PMS is focused on background information for implementation of LCA in network level considerations, with particular focus on environmental impact trade-offs between materials production and construction for M&R treatments and vehicle use impacts.

A PMS has been defined as consisting of three major components:

1. a system to regularly collect highway condition data
2. a computer database to sort and store the collected data
3. an analysis program to evaluate repair or preservation strategies and suggest cost-effective projects to maintain highway conditions (Federal Highway Administration 2013a).

PMS analysis programs typically include a set of tools or methods which help to identify current pavement conditions, predict future pavement conditions, estimate costs, and identify and prioritize pavement M&R projects. Most PMS also include processes for regularly collecting and loading into the database information about construction (treatment type, structural change, location, date and cost), traffic and climate, as well as extensive software tools for visualization and reporting.

A generic PMS can be split into two main functions: storing data about the current and past conditions of the network, and tracking current and future projects

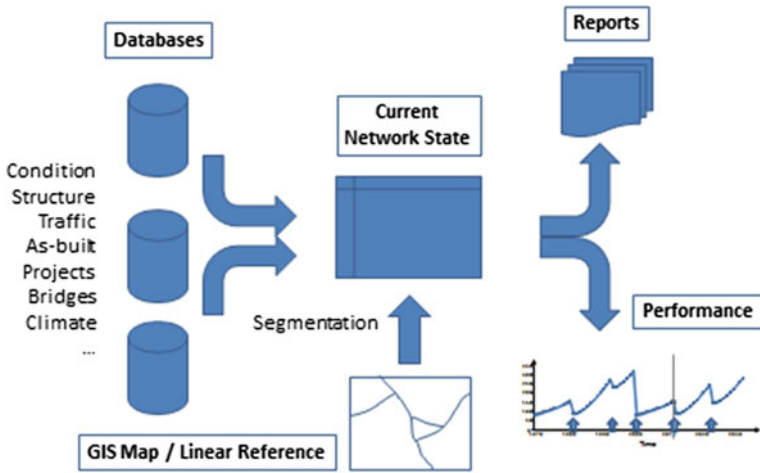

Fig. 2.1 Generic PMS

to change the network. Figure 2.1 shows the first aspect of a generic PMS, including the division of the network into segments with similar structure, traffic and climate, which is the level at which treatment decisions are made. Figure 2.2 shows the typical PMS work flow for the second aspect. This tracking of projects is performed continuously, both as the network changes and as projects are executed. However, most agencies work on an annual cycle to develop annual pavement repair/preservation programs with the goal of meeting the defined objectives for the pavement network within budget and political constraints. Defining those objectives and constraints and performing some sort of optimization is part of many PMS, and there are various kinds of objectives and optimization that are used, as is discussed later in this chapter.

Treatment decision-making at the network level in the PMS typically results in the selection of a general treatment type based on the data available. In the broader sense, pavement management also includes the policies, processes and tools used to perform in-depth evaluation and design for the network segments selected for treatment, which is referred to as project-level pavement management. Outcomes of project-level pavement management are the details of the treatment, such as material types and layer thicknesses, more precise cost estimates and construction specifications.

Data collected at the network level is typically selected from the following:

- Ride quality data in terms of the International Roughness Index (IRI). In some cases IRI is translated back to previous ride quality indices to provide continuity in time histories; and
- Surface distress data, which can include:

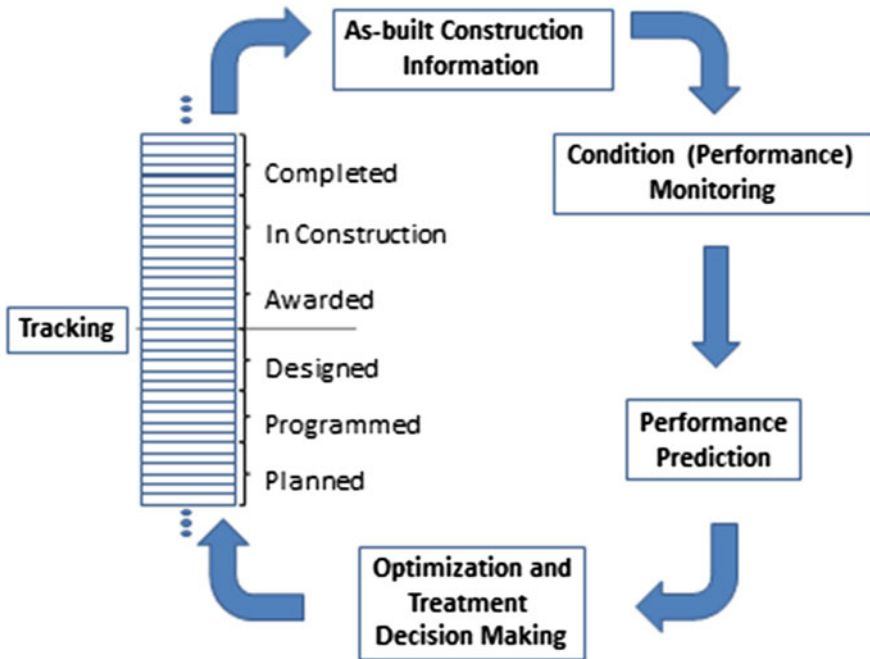

Fig. 2.2 Generic annual work flow of PMS

– Cracking

Traffic load related cracking in the wheelpaths and non-load related cracking out of the wheelpath for asphalt surfaced pavements caused primarily by environmental conditions such as low temperatures, rapid changes in temperature, and aging of the asphalt due to exposure to heat and air.

Various types of cracking (transverse, corner, longitudinal) for concrete surfaced pavement caused by interaction of traffic loading and environmental loading such as temperature gradients, drying shrinkage gradients.

- Load related surface problems such as rutting, raveling and potholes, often accelerated by moisture damage for asphalt surfaced pavements, and faulting and punchouts for different kinds of concrete surfaces.
- Other climate or materials related problems such as raveling for asphalt pavements and D-cracking for concrete pavements.

The data collected are dependent on the pavement management network-level objectives of the agency, and may also support other types of required reporting and improvement of project-level objectives. Research starting in the late 1950s at the AASHO Road Test (Highway Research Board 1961) has shown that the users of the pavement primarily care about the ride quality, and generally do not care much



about surface distresses unless they are severe. However, pavement engineers need to pay attention to surface distresses because ride quality is affected when they reach an advanced state, and because surface distresses lead to more rapid and serious deterioration of the pavement structure. Pavements can have poor ride quality from the time of construction, which can be managed through design and specifications for construction smoothness, whether it is new construction, rehabilitation or maintenance. Specifications that are based on measurement of IRI, as opposed to older methods of profile control, such as the profilograph, have been shown to be more effective in obtaining smooth pavement (Karamihas 2004). Ride quality is often not affected when initial cracking or other distress mechanisms first appear on the pavement surface, and only deteriorate rapidly when the surface distresses move to an advanced state. For this reason, ride quality is a lagging indicator of deterioration within the pavement.

Based on this relationship between ride quality and surface distresses, and the road users' concern about ride quality and not distresses, it might be surmised that treatment should only be applied when the ride quality is bad enough for the users to notice. However, the caveat is that the cost of treating a pavement to bring it to an acceptable ride quality condition when it is in an advanced state of deterioration is much higher than when damage mechanisms are just beginning to appear as surface distresses. The cost of a rehabilitation treatment can be approximately two to ten times greater than that of a maintenance treatment (Galehouse et al. 2003; Sinha et al. 2005; Smith et al. 2005). Applying treatments at about the time that cracking is appearing and before the cracks let water into the pavement and accelerate the damage process is referred to as "pavement preservation" (Federal Highway Administration 2005). Rough pavements also accelerate the damage process by inducing dynamic effects in the suspension of the heavy vehicles which causes them to bounce as they move down the pavement, applying heavier loads than would be indicated by the static load of the wheels, by as much as 20 % (OECD 1998; Cebon 1999). The difference in the cost of the treatments does not mean that the life cycle cost is two to ten times less for preservation than rehabilitation, because preservation treatments must be applied more frequently than rehabilitation treatments. However, research has provided preliminary indications that a strategy of applying several properly timed pavement preservation treatments between rehabilitation treatments can reduce life cycle cost by up to about 20 % (Smith et al. 2005; Lee 2010; Harvey et al. 2012b). Preservation treatments can also be used to help maintain the smoothness of the pavement surface, particularly when there is a construction smoothness specification.

Most state and provincial departments of transportation and some local government road agencies in North America use life cycle cost analysis (LCCA) to help them make decisions at the project level, such as selection of pavement structure type, design life and rehabilitation type. Life cycle cost considers the cost of the initial construction and project management, and the expected sequence of future maintenance and rehabilitation treatments that are dependent on the initial new pavement or rehabilitation decisions. LCCA may also include road user costs such as traffic delay or total road user costs including vehicle operating costs and safety

(Federal Highway Administration 1998; Bennett and Greenwood 2002). An example plot of life cycle costs is shown in Fig. 2.3 (Federal Highway Administration 2002). The plot includes the costs to the pavement owner of initial construction and the maintenance and rehabilitation that follow in the analysis period and whatever road user costs are included in the analysis. All of these costs are summed, typically considering a discount rate, either as the Net Present Value or an Equivalent Uniform Annual Cost. If the rehabilitation or maintenance retains value past the end of the analysis period then a “salvage value” is subtracted from the summation of the costs.

Although there has been a great deal of academic research on optimization in network level pavement management, selection of a program of treatments for a year or for a multi-year horizon in practice today typically does not include life cycle cost optimization directly. The reason for this is that LCCA requires a future stream of activities, but the goal of network-level PMS decision making is to determine this set of activities. There are no optimization algorithms that allow for the simultaneous selection of optimal future actions on a segment and the selection of actions across segments within a given time period. Network-level PMS research has focused on using generic performance models and treatment types to determine optimal intervention strategies (such as “place a thin overlay every eight years”, or “grind the pavement when the roughness reaches 170 in/mi”). These are then implemented within the software as decision trees that trigger a project when the criteria are met. This theoretically results in an optimal selection of projects across the network.

However, in most cases, the agency using the PMS is interested in determining specific locations in need of treatment and constraining the cost of treatment to some budget. As a result it is necessary to perform an additional constrained optimization within each time period to select the specific treatments to implement, and this requires some basis to rank treatments. For this purpose, many states and

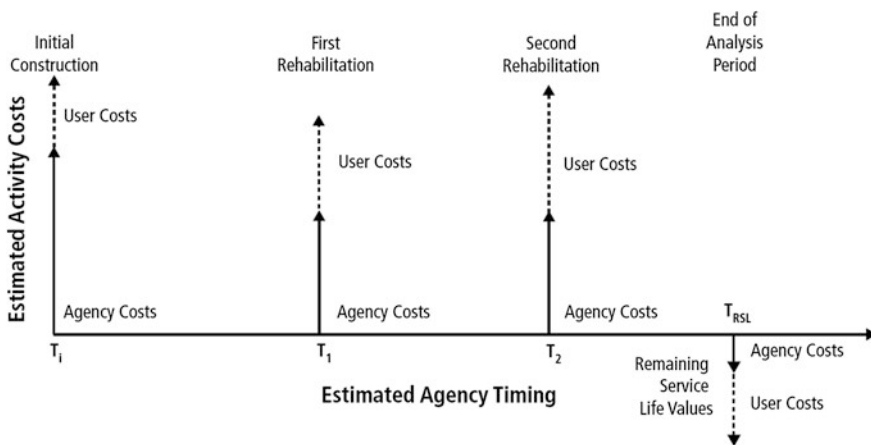

Fig. 2.3 Example LCCA plot (Federal Highway Administration 2002)

local agencies use various types of benefit/cost analysis, where the benefits are calculated in terms of the difference in pavement condition over the analysis time horizon between treating the pavement and not treating it, in terms ride quality or surface distresses or a combination of the two (Hudson et al. 2011). The difference in condition between treating and not treating the pavement is estimated using performance prediction equations, that are typically based on empirical regression of past ride quality and surface distress data.

### 2.1.1.2 Life Cycle Assessment

Environmental life cycle assessment (LCA) is a method developed in the 1960s for identifying environmental objectives, defining the system to be analyzed, quantifying environmentally important inputs and outputs to the system over a life cycle, and assessing the impacts (Guinée 2012). LCA is used to analyze the environmental impacts of an industrial product, and is used for the following four purposes (International Organization for Standardization 2006):

- Identifying opportunities to improve the environmental performance of products at various points in their life cycle.
- Informing decision-makers in industry, government or non-government organizations (e.g., for the purpose of strategic planning, priority setting, product or process design or redesign).
- The selection of relevant indicators of environmental performance, including measurement techniques.
- Quantifying product information (e.g., implementing an eco-labeling scheme, making an environmental claim, or producing an environmental product declaration).

LCA examines a product from cradle to grave, evaluating all the inputs and outputs from raw material production to the final end-of-life. LCA can be used for comparing products, and identifying the benefits and impacts of changes in the production, use and end-of-life (EOL) of a given product. LCA can help identify unintended negative consequences that can occur when making changes in a system or product, such as a pavement network, to help reduce the environmental impact. LCA helps identify unintended consequences of changes by applying the concepts of system analysis and consideration of effects over longer time horizons included in the decision-making process. LCA can also be used to support decision-making when tradeoffs between competing environmental goals must be considered.

The system boundaries for LCA are often determined by the goal of the assessment, which can be grouped into the following two categories, although both types of goals may be included in the assessment:

1. Modeling and quantitative assessment of the inputs and outputs from production and use of an industrial product that considers total system-wide environmental

burdens and the entire life cycle of the product, and then assesses the impacts on humans and the environment, referred to as *attributional analysis*, and

2. Modeling and quantitative assessment of the consequences of changes in the systems, through calculation of the resultant inputs and outputs over the life cycle and assessment of the corresponding impacts, referred to as *consequential analysis*.

For pavement environmental assessment, the life cycle includes the material production, construction, use, M&R, and end-of-life (EOL) phases. Figure 2.4 shows an example of a generic pavement life cycle for LCA.

The materials production and construction phases of both new pavement construction and M&R are discussed in detail in other chapters in this book. Practices for minimization of virgin materials use through recycling, shorter materials transportation distances, and use of lower impact materials are the primary means of reducing environmental impact. As can be seen in Fig. 2.4, there are a number of different sources of environmental impacts that can be considered in the use phase.

Decisions must be made when performing an LCA regarding what will be considered in the assessment and what will be left out, depending on the goal of the assessment. Of the impact sources shown in the figure, vehicle operation is the one that is applicable for all of the pavements in a road network, and is the primary one considered in this chapter. Lighting and heat island effects primarily have to do with selection and maintenance of the reflectivity of the pavement surface. Stormwater runoff can be influenced by pavement maintenance but is mostly affected by drainage and stormwater treatment design and maintenance. In the end-of-life

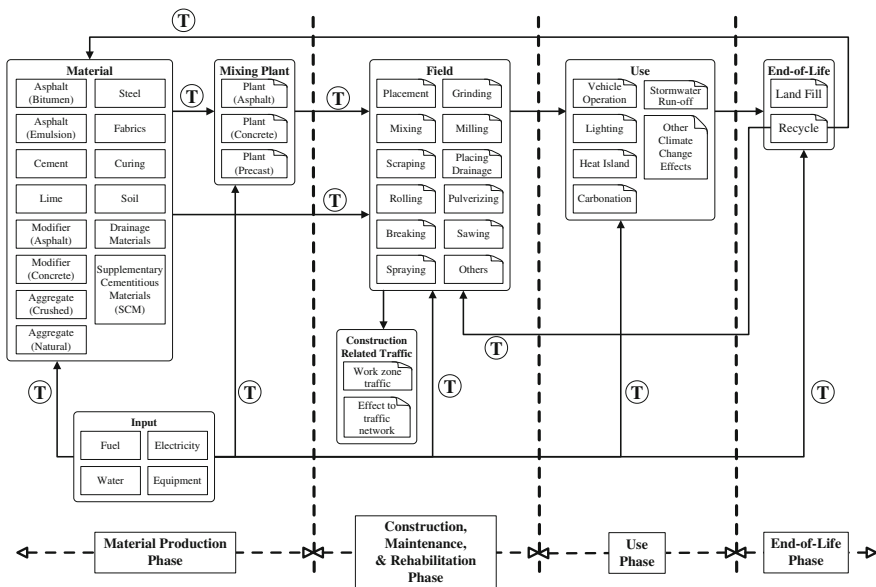

Fig. 2.4 Example diagram of generic pavement life cycle system (Wang et al. 2012a)

phase, recycling brings materials from the existing pavement or from other pavement sources into the new treatment and includes consideration of any transportation, processing and mixing with virgin materials during construction. Some materials remain in place for the entire analysis period.

Vehicle operation in the use phase is typically considered in terms of the effects of the pavement on the fuel efficiency and emissions of vehicles through three mechanisms which together can be called the pavement related rolling resistance, although that is not a precise definition of rolling resistance. The pavement influences can be summarized as follows:

1. Consumption of energy through the working of shock absorbers, drive train components, and deformation of tire sidewalls as the wheels pass over deviations from a flat surface with wavelengths between 0.5 and 50 m in the wheelpath—converting mechanical energy into heat which is then dissipated into the air—and thus requires greater work by the engine. This mechanism is managed by maintaining smoother pavement as measured by IRI. Models for this mechanism are well established and there has been validation by direct measurement.
2. Consumption of energy through viscoelastic working of the tire rubber in the tire/pavement contact patch as it passes over positive macrotexture of the pavement surface and converts it into heat that is dissipated into the tire and the air. Positive macrotexture is caused by stones or grinding/grooving features protruding above the average plane of the pavement surface. Pavements for high speed vehicles must have a minimum amount of macrotexture on the surface, and/or be permeable, in order to remove water films from the pavement surface and to provide frictional resistance for steering and braking. This mechanism is controlled by design of surface treatment, asphalt and concrete mixes and by concrete surface texturing. Raveling on asphalt surfaces and matrix loss on concrete surfaces can increase macrotexture after construction. Models for this mechanism are well established and there has been validation by direct measurement.
3. Consumption of energy in the pavement itself through viscoelastic deformation of pavement materials under passing vehicles, primarily heavy trucks, which has also been modeled in terms of the geometric relationship between the shape of the deflected pavement under the wheel and the wheel itself. The significance of this mechanism for different types of pavement, different vehicles and vehicle operations, and climate regions, has not been clearly established. Experiments have shown that this mechanism can have a significant effect for slow moving heavy vehicles operating on hot viscoelastic pavement, but the significance and models for other vehicles and conditions is not yet well verified. Models with different approaches have been developed, but have not been comprehensively compared or validated with direct measurement.

The relative importance of these mechanisms varies depending on pavement type, climate, materials, traffic characteristics (vehicle types, speeds, chain use) and surface roughness and texture management practices. Other effects of the pavement

on vehicle operation, such as the environmental impact of more frequent replacement of tires, vehicle components, and the life of the vehicles themselves are generally not considered, but could be.

### ***2.1.2 Objectives of Current Pavement Management Systems and Consideration of Environmental Objectives***

The objectives of a pavement management system can include many important goals, and are selected based on what is most important to each road owning agency. To a degree, traditional pavement management objectives can be grouped into two categories, with the titles borrowed from the Strategic Plan of the California Department of Transportation (Caltrans) (Caltrans 2007):

- Mobility, which can related to “functionality”, meaning keeping the pavement safe and efficient for the road user, which is what the user cares most about;
- Stewardship, which can be related to maintaining the structural condition of the pavement, which is what the owner often cares most about.

A review of the objectives of a sample of state and provincial pavement management systems by the authors revealed that the most common mobility objective is articulated in terms of ride quality, as quantified by the IRI. This can be included in the optimization and constraint functions of the PMS in terms of minimizing IRI over the network, IRI trigger values in decision trees for M&R, or maximization of IRI benefits for a given cost. Since mobility objectives have to do with maximizing the benefits of network operation for the road user, IRI objectives are sometimes weighted based on traffic levels. At a next level, total road user cost equations as a function of IRI and vehicle types in the traffic flow can be used for optimization (Harvey et al. 2012a). IRI is the pavement condition parameter that the states are required to report by the Federal Highway Administration (FHWA) as part of the Highway Performance Monitoring System (HPMS). The MAP-21 transportation funding legislation increases the scope of the National Highway System to include principal arterials, which might be managed by local government, and would require annual IRI measurements on these routes. In addition, MAP-21 requires performance based management of all roads receiving federal funding, and it is highly likely that IRI will be the primary performance measure used.

The most common stewardship objectives seen in state PMS implementation are articulated in terms of the level of surface distresses. These may be expressed in terms of particular distresses, such as load related cracking in the wheelpaths for asphalt surfaced pavements and cracking in concrete pavements, or in terms of an aggregation of surface distresses with various scales and weighting equations reported in terms of a Pavement Condition Index (PCI), typically normalized to a 100 (best condition) to zero (worst condition) scale. When the objectives are in terms of specific surface distresses, the implementation can be in terms of

constraints for maximum allowable extents for different severities of the most important surface distresses and optimization of the amount of the network with those distresses. Typical implementation of PCI based objectives is in terms of constraints for minimum PCI values, or optimization to maximize the PCI on the network.

Consideration of environmental indicators in pavement management is receiving increasing attention due to the growing concern regarding the environmental impact of pavement management and practices, particularly with regard to human causes of climate change. Currently, environmental indicators are generally not included in the evaluation of alternative strategies at the network level. Life cycle assessment is one of the approaches commonly adopted to evaluate environmental impacts. However, most effort to date has focused either on project level assessments, with most of those focused on the materials production and construction phases according to a relatively recent review by Santero et al. (2011b). Recent work has included more focus on environmental impacts of pavement condition and structure on vehicle use. Pilot studies have been performed to incorporate LCA results within the traditional cost-based framework in pavement management using multi-criteria optimization (Lidicker et al. 2013).

It will be seen in the remainder of this chapter that traditional mobility and stewardship objectives for PMS decision-making result in different environmental impacts, which can be dealt with through implementation of LCA at the network level.

### ***2.1.3 Selection of Objectives for Network-Level Analysis of Environmental Impacts***

According to ISO standards, a complete LCA study should include life cycle impact assessment (International Organization for Standardization 2006). Life cycle impact assessment is the part of LCA where various life cycle inventory results are translated into the evaluation of potential human health and environmental impacts. The LCA guideline published by the U.S. Environmental Protection Agency (EPA) has selected eleven commonly used life cycle impact categories (U.S. Environmental Protection Agency 2006), including:

1. Global warming
2. Stratospheric ozone depletion
3. Acidification
4. Eutrophication
5. Photochemical smog
6. Terrestrial toxicity
7. Aquatic toxicity
8. Human health
9. Resource depletion

10. Land use

11. Water use.

The ISO has used nine similar categories (International Organization for Standardization 2006). A number of studies have selected the commonly used impact categories and developed the detailed methodology for impact assessment, such as the TRACI impact assessment methodology (Bare 2011; U.S. Environmental Protection Agency 2012) and the CML methodology (Guinée et al. 2002). TRACI is the most commonly used methodology for impact assessment. The most recent version of TRACI (v2.1) was released in 2012, using midpoint indicators on ten impact categories and detailed methods for characterization. Normalization and weighting are not included in TRACI due to their high uncertainties. The CML methodology is another widely used global impact assessment method, with detailed guidelines regarding impact category selection, characterization, normalization and weighting.

As can be seen, there are a large number of impact categories that can be considered, and some assessment should be made in decision-making to check that optimization of one or more categories does not cause unintended large increases in others. However, it is clear that only a few objectives can formally be included in decision-making in a PMS and that many of the categories will not be significantly affected by most PMS decisions. Most LCA databases include information needed to consider most of these impact categories quantitatively although they often do not fully account for regional variability of impact and can become out of date as practice changes.

Many road owning agencies have developed objectives that are considered environmentally beneficial, but have not necessarily been tested in terms of their life cycle impacts, or in terms of their effects on the impact categories used by the US EPA and ISO that are listed above. Some typical objectives that can be seen today are for the amount of recycled material to be used, which is part of the life cycle that by itself does not determine how it affects the total life cycle impacts. For example, inclusion of some types of recycled materials into pavement treatments may result in increases in resource depletion as well as other impacts over the life cycle because the recycled material poses toxicity problems that prevent future recycling of the pavement, or it causes poor performance which results in more frequent need for treatment. For these reasons it is recommended that a life cycle analysis be performed, and that each impact category be at least cursorily considered in the assessment.

It can be argued that the most important impact category affecting all species of life and the underlying ecology of the entire planet is global warming, and that it has overlapping effects on many of the other categories such as acidification of ocean waters, photochemical smog (through increases in temperature), impacts on terrestrial and aquatic life (through changes in climate conditions), human health (through increases in temperature, severe weather events, climate change affecting agriculture and sea level rise) and water use (through climate induced drought reducing supply). Pavement management can have a definite impact on global



warming (and related energy use) and resource use (aggregate, asphalt, cement, lime, steel and other resources to a lesser degree), as two important measures of environmental impact affecting sustainability. Global warming reductions in the transportation sector caused by reductions in burning of vehicle fuels derived from oil will also have positive impacts on photochemical smog, terrestrial toxicity, aquatic toxicity, human health and resource depletion. Reductions in ethanol based fuels will also have positive impacts in other categories including land use, water use and human health through increases in food prices. Other impact categories are also important, with the importance varying depending on local conditions and practices which should be taken into consideration when prioritizing the goals of the LCA.

### ***2.1.4 PMS System Requirements to Meet Objectives***

#### **2.1.4.1 Network-Level Decisions**

A number of different decisions can be made to achieve network-level environmental impact objectives in the PMS. In each case the life cycle must be considered, including the effects of materials production, construction, performance in the use phase including the functional life, and the end-of-life considering the ability to recycle and any constraints on future decisions imposed by the current decision. The decisions can be supported by analyses performed directly in the PMS, or through analyses performed outside of the PMS and then included as policy in the PMS. Some types of decisions include:

- M&R design life selection for inclusion in the PMS decision trees, or comparison in the PMS of alternative design lives for each segment.
- M&R treatment selection for inclusion in the PMS decision trees, or comparison in the PMS of alternative design lives for each segment.
- M&R trigger levels based on pavement condition for inclusion in the PMS decision trees, or comparison in the PMS of alternative design lives for each segment.
- Allocation of funding for M&R of pavement versus other transportation investments; this decision would be made at the level of allocation of transportation funds, but the PMS can be used to compare the environmental impacts of pavement M&R versus other transportation investments to help determine pavement funding levels.

In all of these cases, the decisions need to be based on comparison of the environmental impacts of different treatments for the situations that occur in the network, considering pavement type and condition, traffic levels, climate and availability of materials and contractor capabilities. These will likely be very different between networks, as well as within networks.

### 2.1.4.2 Required Data and Modeling

Life cycle inventory (LCI) data is needed for the M&R treatments included in the PMS. LCI data is the “accounting” of inputs into the life cycle, such as materials, energy and other resources, and the environmental outputs of emissions, pollution and waste. These input and output data that are needed depend on the impact categories that are being quantitatively assessed.

The LCI data is typically organized by constituent materials, such as aggregate, asphalt and cement, used in pavement materials. Some of the current gaps in LCI data for pavement materials, as well as efforts and approaches to fill those gaps, are discussed elsewhere in this book, and in references such as Harvey et al. (2011), Santero et al. (2011a), Federal Highway Administration (2013b) and Lee (2013). LCI data for materials production and construction should be relevant to the region where the PMS has been implemented, and updated to consider changes in materials production and construction data over time. LCI for the use phase should be relevant to the vehicle fleet, traffic operating speeds, climate and other regional conditions.

Treatment selection and triggering models are also needed to determine what decisions regarding treatment will be made for different pavement conditions.

Pavement performance models are needed to determine when treatments will be triggered. Pavement performance models in many PMS are in terms of Pavement Condition Index. Additional performance models for roughness, texture and/or deflection are needed for the use phase for consideration of vehicle energy use, depending on which mechanisms of vehicle fuel use are being modeled.

Additional data may be needed to support models in the PMS including traffic data (volume, vehicle composition, speeds, and hourly flows) and climate data (temperatures and rainfall). Cost data are needed to be able to bring economic considerations into the environmental assessment, and can include road user costs as well as road owner costs.

## 2.2 Example Application to a PMS System

### 2.2.1 Goal, Impact Category and Network Considered

#### 2.2.1.1 Goal and Impact Category

The example is taken from a study performed for the California state highway network (Wang et al. 2014). Global warming is the focus of the example presented in this chapter, with energy use selected as a secondary impact category. The goal of the application is to develop the optimal roughness value (indicated by IRI) to trigger a maintenance treatment that brings the largest GHG emission reduction on the state highway pavement network in California compared to no strategic intervention on the pavement condition (*Do Nothing*), for inclusion in the PMS.

The GHG emission reduction were also calculated to compare with recently implemented Caltrans IRI trigger values.

In this example, a set of common M&R treatments used by California Department of Transportation (Caltrans) was included in the analysis. The set is not exhaustive, but the approach developed can be extended to consider other M&R treatments as data become available and as common practices change.

Global warming was selected in this example because of passage of California Assembly Bill 32 (AB 32) in 2006 which commits the state to meeting the following goals for reducing GHG emissions:

- By 2020: return to 1990 emission levels
- By 2050: reduce emissions to 20 % of 1990 levels.

It is clear from the Scoping Plan for AB 32 (California Air Resources Board 2013) that these goals cannot be met with a handful of strategies, and that they require contributions from nearly every sector of the economy. Lutsey indicated that meeting the 2050 goals will be difficult for the transportation sector with existing proposed strategies and that additional strategies are needed (Lutsey 2008). One strategy not previously considered is reducing fuel use by on-road vehicles caused by the three pavement mechanisms described previously, roughness, rough textures, and high deflections, which can have an important impact because of the large contributions to environmental degradation from road transportation in North America. An example is shown in Fig. 2.5, which shows GHG emissions produced

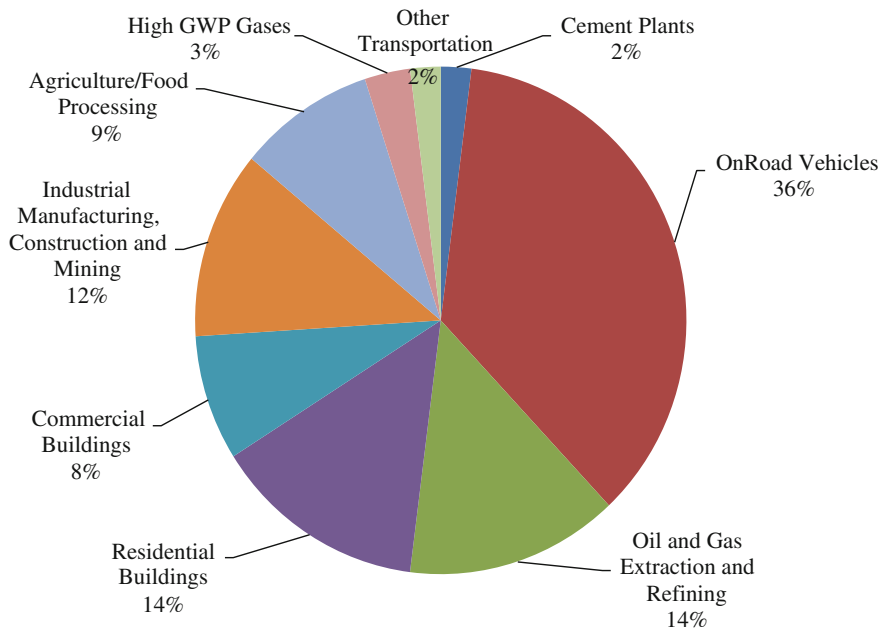

**Fig. 2.5** California’s greenhouse gas emissions (2002–2004 average), direct emissions based on end use (California Air Resources Board 2008)

in California by different industrial sectors in 2008 (California Air Resources Board 2008). Note that each state will exhibit a different distribution than is shown in Fig. 2.5, depending on climate, energy sources and other factors), and the US national average for on-road vehicles is about 22 % of total GHG emissions (U.S. Environmental Protection Agency 2013).

Pavement maintenance and rehabilitation treatments can reduce pavement roughness and positive surface texture, and pavement rehabilitation or reconstruction can reduce vehicle energy consumed by deflections, and therefore lower fuel use and GHG emissions in the on-road vehicle sector shown in Fig. 2.5. However, performing these treatments also requires energy and produces emissions. Specifically, maintenance, rehabilitation and reconstruction of pavement requires materials production and construction, which also contribute to the following three other GHG-emissions source categories shown in Fig. 2.5:

- Extraction and refining of oil: a portion of this sector's emissions come from the production of paving asphalt.
- Cement plants: a portion of this sector's emissions includes the manufacture of cement used for pavements.
- Industrial manufacturing, construction and mining: a portion of this sector's emissions includes some of the processes used for pavement M&R and reconstruction, including mining and transportation of aggregate, manufacture and transportation of lime and construction equipment operations.

As shown by Lidicker et al. (2013) and Wang et al. (2014), optimization of pavement treatments requires balancing of the GHG emissions caused by pavements needing treatment, and the emissions caused by performing those treatments.

GHG emissions are measured in terms of equivalent metric tons of carbon dioxide (CO<sub>2</sub>-e), which is the most common indicator used for global warming. This indicator is a midpoint indicator (as opposed to an endpoint indicator such as human health impacts due to sea level rise or damage to ecosystems), and its use is supported by various scientific studies (IPCC 2007a). Although energy consumption is closely tied to GHG emissions through the burning of fossil fuel, there are some situations where GHG emissions are not generated from burning fossil fuel, such as the pyro process in cement production and CH<sub>4</sub> emissions that occur during construction equipment usage. Each type of GHG can be converted to CO<sub>2</sub>-e based on its contribution to the radiative forcing compared with CO<sub>2</sub> (IPCC 2007b).

### 2.2.1.2 Description of the Network

Table 2.1 gives a brief description of the highway network based on the Caltrans PMS.

Figure 2.6 shows some descriptive statistics of the highway network in terms of pavement surface type, traffic levels and IRI. The traffic levels are in terms of passenger car equivalent (PCE), where each truck is 1.5 equivalent passenger cars (Transportation Research Board 2010). The different types of pavement and the

**Table 2.1** Summary statistics of the state highway network

Pavement type	Lane-miles	Maximum AADT	Minimum AADT	Mean AADT	AADT standard deviation
Asphalt	37,233	210,600	48	37.065	39.730
Concrete	10,721	225,551	675	79.708	37.988

Note: AADT = Average Annual Daily Traffic

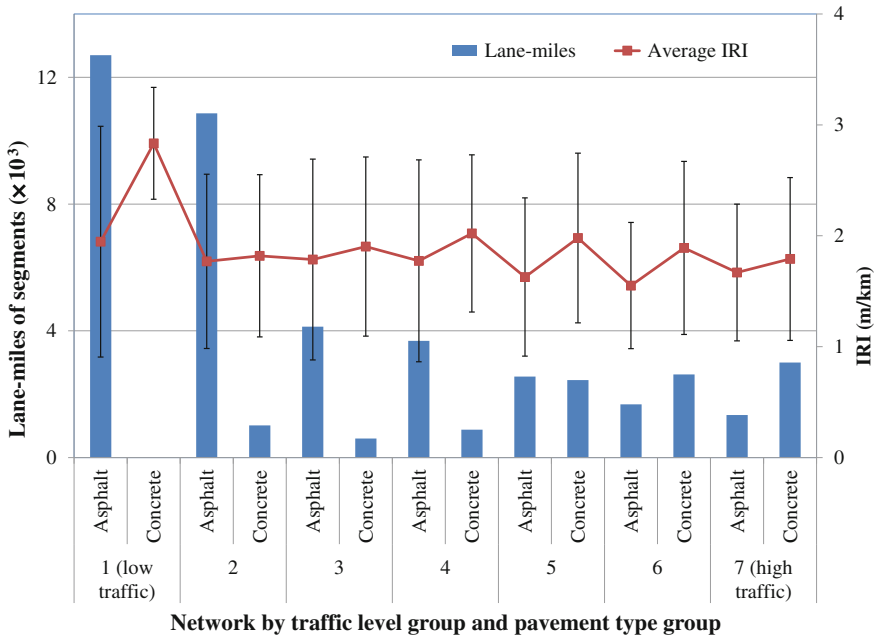

**Fig. 2.6** Descriptive statistics of IRI and lane-miles on each traffic level (PCE) group, *Note 1* Traffic level groups are *Group 1* PCE lower than 2,517; *Group 2* PCE from 2,517–11,704; *Group 3* PCE from 11,704–19,108; *Group 4* PCE from 19,108–33,908; *Group 5* PCE from 33,908–64,656; *Group 6* PCE from 64,656–95,184; *Group 7* PCE higher than 95,184., *2* The error bar shown with the average IRI value is the standard deviation of the IRI in each group., *3* There are only 0.9 lane-miles of concrete pavement in Group 1 (lowest traffic), so the average IRI value in that group combination is very high and may not be representative. *4* The PCE is only used to divide the network into groups. When calculating pavement deterioration and vehicle fuel economy, segment-specific algorithms and emission factors for each type of vehicle are applied

pavements in each traffic group have different demographics in terms of pavement age and time since last surface treatment. They also reflect some design practices used when much of the network was built in the 1950s through 1980s. The IRI values on the network were extracted from the 2011 Caltrans Automated Pavement Condition Survey (APCS) and used as the initial condition of the network in this example.

The relatively even distribution of IRI across the different pavement types and traffic categories shows the results of an historical use of a stewardship type PMS objective, where treatments were triggered based on the extent of surface cracking rather than IRI, with the traffic level primarily determining the type of treatment. This type of objective helped to ensure that the network was kept in reasonable structural condition regardless of traffic level. A mobility or functional type of PMS objective may have resulted in lower levels of IRI on segments with higher traffic levels, considering that many treatments for low-volume highways do result in much improvement in smoothness. If an IRI objective was traffic weighted, it would have likely resulted in lower IRI values for the higher traffic segments than for the lower traffic segments.

### ***2.2.2 Network-Level Considerations for GHG Example***

Previous studies have shown that performing an M&R treatment on a rough pavement can lead to significant energy savings and GHG reductions (Wang et al. 2012b). However, the question of what level of roughness should trigger the M&R activity so the GHG reduction can be maximized over an analysis period was unanswered. Figure 2.7 demonstrates this interaction: if the triggering roughness is set too low (Fig. 2.7a), the materials production and construction processes required to maintain a smooth pavement with frequent M&R treatments can exceed the CO<sub>2</sub>-e reduction from improved fuel economy in the use phase. On the other hand, if the triggering roughness is set too high (Fig. 2.7b), the additional CO<sub>2</sub>-e due to vehicles operating under rougher conditions may exceed the theoretical material and construction emissions that would occur from more optimal pavement M&R.

Considering the heterogeneity of the highway network, setting one IRI triggering value for the whole network may lead to large differences in environmental impact. Each segment in the network has its unique traffic level, traffic composition, and pavement characteristics, and theoretically, developing an IRI triggering value for each segment in the network within the PMS can improve the precision of the optimized result. However, such complexity may not be practical for an approach to be implemented at the network level at this time. The example summarized in this chapter adopted traffic level as the indicator to divide the network into groups as discussed in the last section, and then developed the triggering value for each group in the network for inclusion in decision trees.

To identify the optimal IRI trigger, each segment in the network is evaluated through two scenarios with a series of IRI triggers: the *M&R* scenario and the *Do Nothing* scenario. In the *M&R* scenario, when the IRI of a segment reaches the triggering value, a treatment is performed and brings down the IRI. The emissions from the material production and construction are calculated based on the material quantity and construction activity. The GHG emissions in the use phase are calculated based on vehicle operation under the corresponding pavement conditions. In the *Do Nothing* scenario, the pavement is preserved using routine maintenance

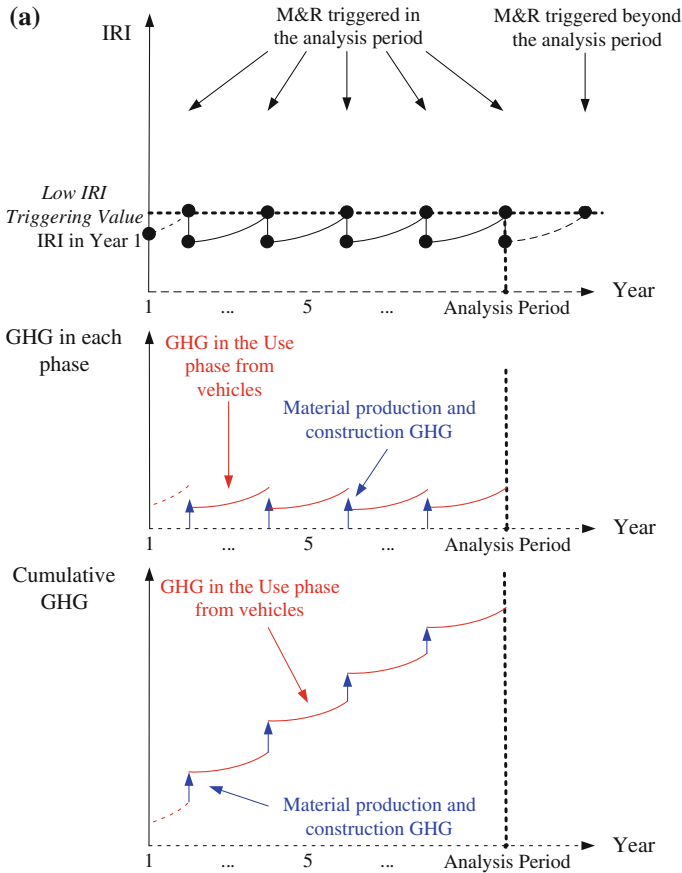

**Fig. 2.7** How IRI triggering value affects the M&R activities and the resultant GHG: **a** a low IRI triggering value; and **b** a high IRI triggering value

such as localized patching and digouts (patching of the wheelpaths) to maintain its current roughness and macrotexture. The environmental impacts from material production and construction phases are assumed to be zero. The use phase emissions for the *Do Nothing* scenario are calculated similarly to the *M&R* scenario. The difference in GHG emissions between these two scenarios is summed over the analysis period and all segments in each traffic group. The IRI trigger that leads to the highest GHG reductions is considered the optimal IRI trigger.

A ten-year analysis period, from the year 2012 to the year 2021, was chosen for this example. This is because this example focused on repeated pavement prevention treatments, and pavement prevention treatments have relatively short design lives compared to major rehabilitation treatments. Therefore, a ten-year analysis period is able to cover 1.2–1.5 times the common design life of the two main treatments, as recommended in *UCPRC Pavement LCA Guideline* (Harvey

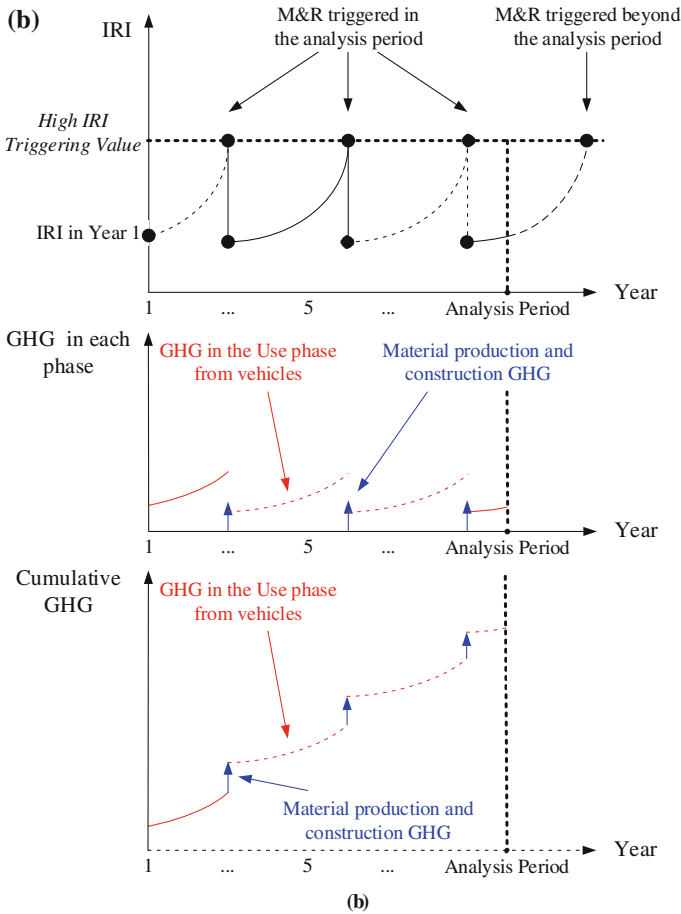

Fig. 2.7 continued

et al. 2011). Further, this example amortized the emissions from the last treatment event, and only included the parts of emissions that are within the analysis period. Therefore, this selection of analysis period was considered reasonable.

### 2.2.3 Specific Modeling and Data for the GHG Example

Some basic inputs are needed to evaluate the life cycle GHG emissions and energy consumption from pavement treatments on the network. These inputs include the emission factors for the treatments, emission factors from vehicles for different pavement IRI and macrotexture levels, pavement performance models for IRI and macrotexture (validated deflection models can be added to future analyses), traffic



data, and pavement type data which helped determine treatment types. Treatment cost and some road user cost data were also used to provide economic comparisons of different IRI trigger levels for M&R.

### 2.2.3.1 Emission Factors and Cost of Treatment

Considering the life cycle of pavement, the emission factor of a treatment usually covers the material production phase and construction phase and should be calculated separately for each phase. However, on the network-level, the emission factors from these two phases can be combined and represented using a reference construction activity, such as one metric ton of asphalt or one lane-mile of concrete that is diamond ground.

Due to the temporal and regional uncertainty of various LCI data sources, multiple data sources for each material are recommended to be included in the development of PMS applications when possible. Some major data sources for pavement include the pavement LCI produced by Stripple et al. in Sweden (Stripple 1998), the asphalt inventory produced by the Athena Institute in Canada (Athena Institute 2006), EcoInvent (Swiss Centre for Life Cycle Inventories 2011), the U.S. Life Cycle Inventory produced by the National Renewable Energy Laboratory (National Renewable Energy Laboratory 2011), and the cement LCI study by the Portland Cement Association (PCA) (Marceau et al. 2006). Because different sources represent different local conditions, technologies, and system boundaries, each item needs to be disaggregated to the process and then recalculated based on local conditions and specifications, such as fuel source, electricity mix, and car and truck emissions per unit of fuel used before being used as the data source (Lee 2013).

In the construction phase, fuel use and GHG emissions are controlled by both construction equipment (including trucks) and construction-related traffic. These need to be summarized for consideration at the network level. A two-step method can be used to assess the impact from construction equipment. The first step is to simulate the construction schedule and equipment activities for typical projects on the network. Various construction scheduling modeling tools can be used to achieve this goal, based on controlling parameters such as pavement structure design, lane closure tactics, and resource availability. The basic procedure of construction scheduling is to first identify the equipment types and then hours of operation typically needed for each treatment type. The second step is to convert the equipment operating hours to GHG emissions and energy consumption using emission factors of construction equipment. Emission models for on-road transportation (for hauling trucks) and off-road construction equipment based on local conditions can be used in this step.

Depending on the scope of a study, the construction-related traffic can be included in the analysis although this will be highly variable. The additional fuel consumption and emissions from work-zone traffic are then analyzed with fuel economy and emission factors from local on-road vehicle emission models.

With material production phase and construction phase data, the emission factors of a treatment can be usually calculated through analyzing a construction activity on a reasonable scale, and normalizing the results to the reference unit for application to the functional unit of a network segment. When put in network-level analysis, the emissions from each treatment can be scaled for lane-miles to be treated or another reasonable factor based on the emissions from the reference unit.

### 2.2.3.2 Vehicle Emission Factors

In assessing the life cycle impact from pavement, the vehicle emission factors are used to address the changes of vehicle emissions due to the deterioration and M&R of pavement. In network-level analysis, the vehicle emission factors are developed as a function of pavement characteristics affected by deterioration and construction activities, which change the roughness and rolling resistance placed on the vehicle engine, eventually affecting the energy power, energy consumption, and emissions. In practice, the vehicle emission factors are developed as a function of all these variables. A factorial approach can be used to develop the vehicle emission factors considering vehicle type, engine technology (gas, diesel, hybrid and electric) and vehicle speed. Of these variables, road type (urban or rural) and road access type (freeway or highway) control the characteristics of vehicle speed including congestion, while calendar year and vehicle type control the engine technology and emissions control requirements of vehicles, and pavement type and pavement surface characteristics control the impact of pavement on vehicles' rolling resistance. Table 2.2 shows an example of the combination of the factorial variables. In this example, the vehicle emission factor is developed for each combination of variables. Therefore, the total number of the combinations was 2 pavement types  $\times$  2 road types  $\times$  2 road access types  $\times$  10 years  $\times$  5 vehicle types = 400. The emissions factors were developed based on integration by Wang et al. (2012b) of HDM-4 fuel use equations calibrated by Zaabar and Chatti (2010) with emissions factors included in the US EPA's *MOVES* models (U.S. Environmental Protection Agency 2010).

**Table 2.2** Combination of the complete factorial variables used to develop the vehicle emission factors as a function of MPD and IRI

Pavement type	Road type	Road access type	Vehicle type mix	Pavement surface characteristics
Asphalt pavement; Concrete pavement	Urban roads; Rural roads	Restricted access road (freeway); Unrestricted access road (highway)	Passenger cars; 2-axle truck; 3-axle truck; 4-axle truck; 5 or more axle truck at Year 2012–2021 (10 years)	MPD and IRI
Categorical variable	Categorical variable	Categorical variable	Categorical variable	Continuous variable

### 2.2.3.3 Traffic

Traffic is a crucial input in evacuating the life cycle impact from pavement because traffic can affect the pavement from two perspectives: (1) pavement deterioration rate is a function of truck traffic; and (2) the pavement roughness affects fuel economy of every vehicle that uses it differently (both passenger cars and different types of trucks). Therefore, the traffic data acquired for network level pavement life cycle assessment needs to be able to reflect these two aspects. For the pavement performance models used in this example, the damaging effects of truck traffic were characterized in terms of 80 kN (18,000 lb) equivalent single axle loads (ESAL). Because different lanes carry different levels of truck traffic and therefore have different deterioration rates, the PMS uses lane-by-lane segmentation and the deterioration and emissions are calculated for each lane separately. Caltrans' traffic vehicle classification and flow data was set up to be used by the vehicle emissions equations, with lane assignments of trucks and cars for multi-lane roads made based on Caltrans' weigh-in-motion (WIM) data (Lu and Harvey 2006).

### 2.2.3.4 Pavement Data

Pavement data includes the initial pavement condition and pavement performance equations. For this example, these data include pavement surface characteristics (IRI and MPD) and cracking (used to determine concrete slab replacements or concrete lane replacement). The results from the 2011 Caltrans APCS were used as the initial conditions. Pavement performance equations characterize how pavement conditions progress under difference situations, and include the expected initial change in IRI, MPD and cracking due to treatment. Detailed performance models for IRI and macrotexture in the use phase sub-model can be found in Wang et al. (2014).

The main treatments considered in this example are two *Capital Preventive Maintenance* (CAPM) treatments used by the Caltrans: (1) a medium thickness asphalt overlay applied on all asphalt surfaced pavements, and (2) diamond grinding with slab replacement on concrete surfaced pavement with less than 10 % shattered slabs. This study also includes another treatment, although not in the CAPM category; concrete lane replacements with new concrete when there are more than 10 % shattered slabs. This last treatment is used far less often than the CAPM treatments.

The use phase sub-model did not consider rolling resistance due to pavement deflection, which is the subject of other current research. Reasonable assumptions are made that pavement deflections under traffic would change very little for application of the M&R treatments considered. Macrotexture was considered, although macrotexture values on the California state network are generally low on all but lightly traveled highways where chip seals are used, and chain wear only occurs over a few mountain passes.

### 2.2.4 Network-Level Results from the Optimization

Using the procedure described in the previous sections, this application develops the optimal roughness trigger for each traffic category for the treatments modeled. As examples of network-level implementation in the PMS, the GHG reductions that can be achieved compared with maintaining the network at current levels of roughness (*Do Nothing*) and current Caltrans IRI triggering levels across all segments were compared [see Wang et al. (2014) for this comparison]. The cost per ton of CO<sub>2</sub>-e reduction over a ten year analysis period compared to *Do Nothing* and current IRI triggering levels were also compared.

Figure 2.8 shows the result of GHG reduction in *M&R* scenario compared with *Do Nothing* scenario based on different triggering IRI values on each traffic group in the network. The x-axis shows the IRI value that triggers a treatment. The y-axis shows the total GHG reduction from the treatments compared to *Do Nothing* when a specific triggering value is implemented. It can be seen that if the triggering value is too low, the high GHG that comes with the frequent construction and material consumption can offset the GHG reductions during the use phase of pavement, even if the pavement is maintained at a very smooth level. If the triggering value is set too high, the pavement can get very rough which lowers the fuel economy of the

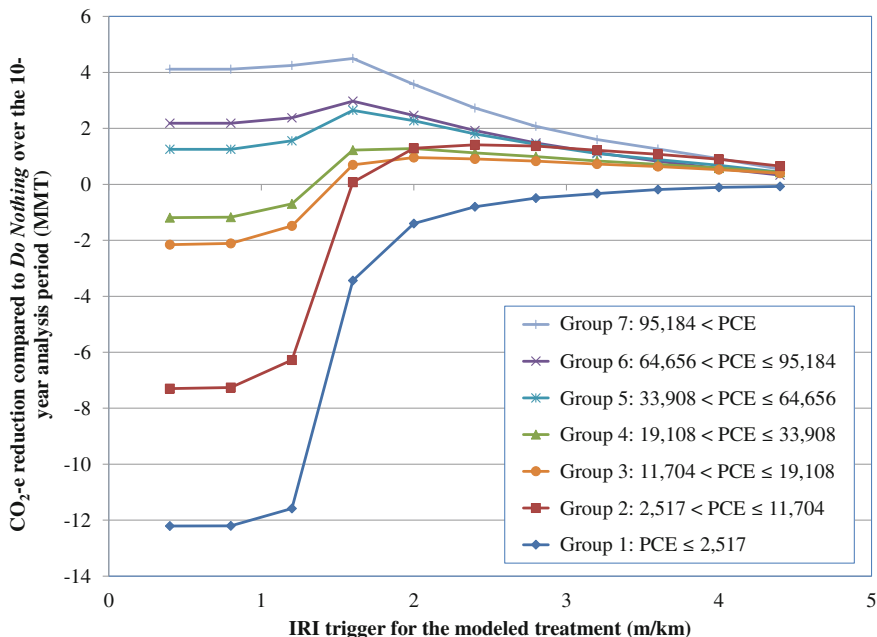

**Fig. 2.8** GHG reductions versus IRI triggering value for different traffic level over the 10-year analysis period for each traffic group

vehicles. Therefore, there is an optimal triggering IRI value that can lead to the highest GHG reduction.

This is the trade-off between the environmental impacts that occur in the material production and construction phases and those that occur in the use phase. The result shows that the highest GHG reduction that can be achieved through performing the analyzed treatments comes from using different IRI triggering values for different traffic level groups in the network. The higher the traffic level is, the lower the triggering IRI value it needs to achieve the maximum GHG reduction. Table 2.3 shows the highest GHG reduction for each group of segments in the network and its corresponding IRI triggering value. It can be seen in Fig. 2.8 and Table 2.3 that the 10 % of the network with the highest traffic (Group 7) provide nearly 35 % of the emission reductions, despite similar or lower current roughness than other traffic groups. For segments with a daily PCE lower than 2,517 the net GHG reductions are negative for any IRI triggering value, indicating the GHG during the material production and construction phases can never get paid back during the use phase within the 10-year analysis period. For these segments retention of Stewardship type PMS objectives is needed to maintain minimal funding for connectivity of the network.

The total amount of GHG reductions that can be achieved if these optimal IRI triggering values are implemented on corresponding traffic levels is 13.77 million metric ton (MMT) CO<sub>2</sub>-e over the 10-year analysis period compared to the *Do Nothing* scenario. For comparison, the California Air Resources Board has estimated that the average annual GHG from on-road vehicles is about 168.1 MMT CO<sub>2</sub>-e between the 2006 and 2020 (California Air Resources Board 2011). Therefore, the GHG reduction estimated from this study can contribute about a 0.8 % reduction compared to the baseline over the 10-year analysis period in the on-road vehicles.

The cost-effectiveness of each IRI triggering value is also shown in Table 2.3. The *modified total cost* shown is the *agency cost* subtracting the cost of saved fuel consumption from the road users due to the improved fuel economy on smooth pavement. Consideration of *total road user cost* including all costs of vehicle operation on rougher pavement as well as safety would reduce the cost per ton of GHG saved. It can be seen the greatest cost effectiveness comes from applying frequent M&R treatments on the pavements carrying the highest traffic volumes.

These results show that a management objective that focuses on traffic-weighted IRI using the optimized IRI values is the most cost-effective approach to reducing GHG emissions using pavement management. However, as noted previously, because IRI is a lagging indicator of pavement distress, a “stewardship” type pavement preservation constraint that addresses cracking before it progresses to the point that it affects IRI will likely increase the cost-effectiveness of the M&R program. A stewardship constraint that addresses low-volume segments is also needed to preserve the connectivity of the network and mobility for rural areas.

The inventory data, impact calculations for each segment over the analysis time horizon and reporting of GHG savings (or increases) that come from treating a pavement or letting it continue to deteriorate have been implemented in the Caltrans PMS.

**Table 2.3** IRI triggering value for the maximum energy and GHG reductions compared to *Do Nothing* over the 10-year analysis period for the entire network

Traffic group number	Daily PCE of directional segments	Total lane-miles in the network	Percentile range of lane-mile in the network (%)	Optimal IRI triggering value (m/km, inch/mile in parentheses)	Energy savings compared to <i>Do Nothing</i> (million MJ)	GHG reductions compared to <i>Do Nothing</i> (MMT CO <sub>2</sub> -e) <sup>1</sup>	Modified total cost-effectiveness (\$/metric ton CO <sub>2</sub> -e)
1	<2,517	12,068	0–25	—	0	0	N/A
2	2,517–11,704	12,068	25–50	2.4 (152)	1.43 × 10 <sup>4</sup>	1.41	1,169
3	11,704–19,108	4,827	50–60	2.0 (127)	1.01 × 10 <sup>4</sup>	0.96	857
4	19,108–33,908	4,827	60–70	2.0 (127)	1.40 × 10 <sup>4</sup>	1.28	503
5	33,908–64,656	4,827	70–80	1.6 (101)	2.94 × 10 <sup>4</sup>	2.64	516
6	64,656–95,184	4,827	80–90	1.6 (101)	3.33 × 10 <sup>4</sup>	2.97	259
7	>95,184	4,827	90–100	1.6 (101)	5.01 × 10 <sup>4</sup>	4.50	104
Total		48,271			1.51 × 10 <sup>5</sup>	13.77	416

*Note*N/A not applicable since no GHG reduction

## 2.3 Gap Analysis for Implementation

### 2.3.1 Survey from the PMS System Capabilities

As stated in the beginning of this chapter, very few road owning agencies have begun to integrate LCA into their PMS, either directly through incorporation of inventory data, impact models, and assessment reporting, or indirectly through inclusion of LCA results into the policies embedded in the PMS, such as decision trees. The criteria for selecting treatment options are usually based on benefit/cost analysis with benefits defined in terms of PCI reductions, reductions of specific types of cracking and other distresses, or reductions in IRI, often without traffic weighting. Remaining service life increases or other measures of estimated structural capacity are sometimes used. Life cycle cost with these pavement condition objectives is seldom used at the network level. As consideration of environmental concerns becomes more important, inclusion of environmental indicators of pavement performance in the analysis capabilities that are included in pavement management systems should receive increasing attention.

The PMS coupled with pavement LCA then provides a practical and powerful tool to understand and report the environmental ramifications of pavement management decisions, and the costs associated with achieving environmental as well as mobility and stewardship objectives. Figure 2.9 shows a possible integration of PMS with pavement life cycle modeling. With a variety of rich data sources provided by PMS to the pavement life cycle modeling, this integration can help to solve the optimization problem, where there are multiple objectives in the optimization (condition, cost and environmental impact) subjected to either a cost budget or emission target.

With PMS coupled with LCA modeling, the M&R frequency (such as setting the trigger value of performing an M&R) and intensity (such as the overlay thickness, or the selection of maintenance versus rehabilitation) can be optimized to reduce environmental impacts. Several research studies have developed case study approaches to achieve these goals. These studies, including Lidicker et al. (2013) and Zhang et al. (2010), attempt to minimize the environmental impacts in the pavement life cycle by optimizing the M&R frequency and intensity based on the selection and scheduling of M&R events.

Zhang's study treated the M&R scheduling as a multistage decision-making problem and used dynamic programming to optimize the environmental impacts on a small set of segments in the theoretical network. The biggest limitation with this study is that it includes a very complex optimization procedure, resulting in a high computational intensity when used on a larger network. Further, this optimization developed segment-specific M&R strategies, making it difficult to implement on the network level. In comparison, Lidicker's study used a Pareto optimal frontier for a single treatment type on a segment to determine the relationship between total life cycle cost (road owner and road user costs calculated separately and then summed over the life cycle) and corresponding GHG emissions. A Pareto optimal frontier is

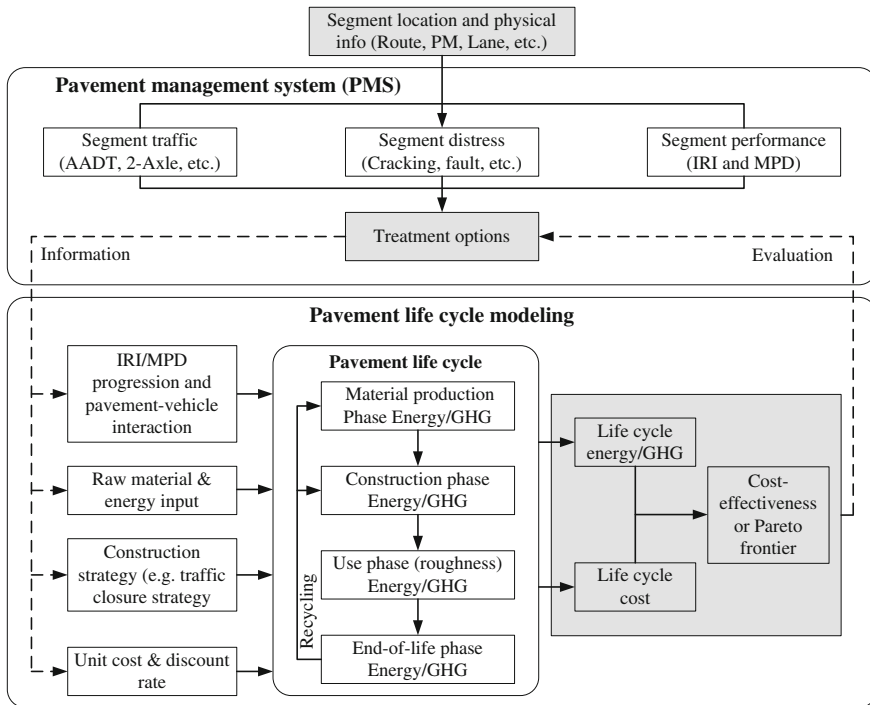

**Fig. 2.9** Integration of the pavement LCA model in the PMS for example of GHG emissions (can be expanded to other impact categories based on available models and inventory data)

a collection of points which are considered optimal from a societal point of view in that one variable (cost or GHG emissions in this case) must be decreased for the other to be increased. The decision as to what is the best combination of benefits then becomes a quantitatively supported decision, and the marginal change can also be determined, in this case the cost of further reducing GHG emissions. The advantage of this study is that it adopted the “triggering roughness” concept, an approach used by many agencies, and therefore has the potential to be integrated and implemented into current PMS. However, this study was only performed on the project level and used a relatively simple emission model. A network-level analysis based on this approach is to be expected in the near future.

### 2.3.2 What Needs to Be Done?

The most important gap in the ability to integrate LCA into PMS is the need for reduction of available life cycle inventory data into regionally applicable, up to date, and simplified form that can be readily implemented, understood and



maintained. Materials production are generally available, but must be related to treatments included in the PMS. This requires reviewing typical mix designs for pavement materials, sources of those component materials, transportation and other sources of resource use and emissions. Construction data can also be developed based on analysis of typical projects for each treatment type. These types of materials and construction databases take several years to implement initial results with an understanding of the uncertainty involved, and then can be steadily improved.

For local government to be able to incorporate LCA into PMS the following are some of the major gaps:

- Databases need to be expanded to consider the effects of utility maintenance on pavement performance.
- Where motorized vehicle use phase effects are considered, methods for collecting roughness at slow speeds for those pavements carrying sufficient traffic to warrant inclusion in the analysis.
- Additional use phase effects specific to wide-spread networks of pavements in urban areas should be evaluated to determine whether they warrant consideration.

Examples produced for project-level analysis are *Dubocalc* (Rijkswaterstaat 2012) produced by the national government of the Netherlands (Rijkswaaterstat) and *Ecorce* (IFSTTAR 2013) produced by the French national government (IFSTTAR). These types of databases can be the basis for developing the simplified data needed for PMS integration. Other agencies are working on similar databases in the United States and Canada. These databases need to be expanded to consider various end-of-life paths for pavements, and must be kept up to date as new technologies for re-using pavement materials are developed, and new materials are created. Allocation alternatives for assigning the environmental burdens for end-of-life scenarios must be turned into policy to be implemented in the PMS.

Use phase models for vehicle emissions based on roughness and macrotexture are available, such as those used in the example in this chapter. They can be expanded to consider other impact categories based on the energy sources used by the vehicles. Models for energy consumed by pavement deflection are available and are undergoing evaluation and calibration. Traffic data, including traffic volumes classified by vehicle type, speeds, congestion, and lane assignment data where the PMS uses lane by lane segmentation, are generally available within state department of transportation for use phase analysis.

From this review, it is clear that information is available. The main work is to review it and make it applicable to the specific agency, and then perform the work of integrating various data sources and implementing them within a PMS. Development of clear and politically supported objectives is also needed for each agency, since it is clear that only a few can be addressed in a PMS and not all impact categories are particularly relevant to pavement. The use of complete life cycle results is also important, since the performance of one phase in life cycle, such as recycling goals, may not produce the intended results in all cases.

## 2.4 Summary and Recommendations

### 2.4.1 Summary

The objective of this chapter is to demonstrate how LCA can be integrated into PMS to assess the environmental impacts from pavement and support network-level decision-making. The data required for such integration and the gap between current PMS and the implementation were also discussed. As an example, a simplified version of a life cycle assessment model was applied to the California state pavement network to evaluate a strategy of application of maintenance treatments and a small number of concrete lane replacements to rough pavement and its potential impact on GHG. The network was broken into different groups based on their traffic level. An IRI value for triggering CAPM treatment that can lead to the highest energy and GHG reductions was developed for each group.

### 2.4.2 Recommendations for Future Work

The LCA model and its application in the case studies and pavement network have shown that using LCA in pavement decision-making can be a powerful tool for assessing impacts of pavement M&R strategies on the environment. However, the results shown in the analysis are only the very beginning of this work for only one objective. Considerable work must be done to fill the gaps identified in this chapter. This work can be also be expanded to network-level management of rail and bridge networks. Project-level LCA studies have been performed for these that provide the basis for future databases and analysis frameworks.

## References

- Athena Institute. (2006). *A life cycle perspective on concrete and asphalt roadways: Embodied primary energy and global warming potential*. Prepared for the Cement Association of Canada.
- Bare, J. (2011). TRACI 2.0: The tool for the reduction and assessment of chemical and other environmental impacts 2.0. *Clean Technologies and Environmental Policy*, 13, 687–696.
- Bennett, C. R., & Greenwood, I. D. (2002). *Modelling road user and environmental effects in HDM-4*. The World Road Association.
- California Air Resources Board. (2008). *Climate change proposed scoping plan: A framework for change*. Sacramento: California Air Resources Board.
- California Air Resources Board. (2011). *Greenhouse gas inventory—2020 emissions forecast*. Sacramento: California Air Resources Board. Retrieved from 2013 <http://www.arb.ca.gov/cc/inventory/data/forecast.htm>
- California Air Resources Board. (2013). *Climate change scoping plan first update discussion draft for public review and comment*. Sacramento: California Air Resources Board.
- Caltrans. (2007). *Caltrans strategic plan 2007–2012*. Sacramento: California Department of Transportation.

- Cebon, D. (1999) *Handbook of vehicle-road interaction*. Lisse: Handbook of Vehicle-Road Interaction.
- Federal Highway Administration. (2002). *Life-cycle cost analysis primer*. FHWA-IF-02-047. Washington, D.C.: Federal Highway Administration.
- Federal Highway Administration. (2013a). *Pavement management primer*. Washington, D.C.: Federal Highway Administration.
- Federal Highway Administration. (2005). *Pavement preservation definitions*. Washington, D.C.: Federal Highway Administration. Retrieved from <http://www.fhwa.dot.gov/pavement/preservation/091205.cfm>
- Federal Highway Administration. (2013b). *Reference document for sustainable pavement systems (draft)*. FHWA-HIF-13-XXX. Washington, D.C.: Federal Highway Administration.
- Federal Highway Administration. (1998). *Life-cycle cost analysis in pavement design: In search of better investment decisions*. FHWA-SA-98-079. Washington, D.C.: Federal Highway Administration, United States Department of Transportation.
- Galehouse, L., Moulthrop, J. S., & Hicks, R. G. (2003). Principles of pavement preservation: definitions, benefits, issues, and barriers. *TR News*, 228, 4–9.
- Guinée, J. B. (2012). Life cycle assessment: Past, present and future. In *International Symposium on Life Cycle Assessment and Construction*. July 10–12, Nantes, France.
- Guinée, J. B., Gorrée, M., Heijungs, R., Huppes, G., Kleijn, R., & Ad, Koning. (2002). *Handbook on life cycle assessment: Operational guide to the ISO Standards*. Dordrecht: Kluwer Academic Publishers.
- Harvey, J., Kendall, A., Lee, I.-S., Santero, N., Dam, T.V., & Wang, T. (2011). *Pavement life cycle assessment workshop: Discussion summary and guidelines*. UCPRC-TM-2010-03. Davis and Berkeley: University of California Pavement Research Center.
- Harvey, J., Lea, J. D., Tseng, E., Kim, C., & Kwan, C. (2012a). *PaveM engineering configuration*. Davis and Berkeley: University of California Pavement Research Center.
- Harvey, J., Rezaei, A., & Lee, C. (2012b). Probabilistic approach to life-cycle cost analysis of preventive maintenance strategies on flexible pavements. *Transportation Research Record: Journal of the Transportation Research Board*, 2292, 61–72.
- Highway Research Board. (1961). *The AASHO road test*. Highway Research Board Special Report 61, National Academy of Sciences, Washington, D.C.
- Hudson, S. W., Strauss, K., Pilson, C., & Hudson, W. R. (2011). Improving PMS by simultaneous integration of MMS. In *8th International Conference on Managing Pavement Assets*. November 15–19, 2011, Santiago, Chile.
- IFSTTAR. (2013). Éco-comparateur ECORCE2. Bouguenais, France. Retrieved from 2013 <http://ecorce2.ifsttar.fr/>
- International Organization for Standardization. (2006). ISO 14044 *Environmental management—life cycle assessment—requirements and guidelines* (2nd ed.). ISO 14044:2006(E). Geneva: International Organization for Standardization.
- IPCC. (2007a). *IPCC fourth assessment report: Climate change 2007 (AR4): Synthesis report*. Geneva: Intergovernmental Panel on Climate Change.
- IPCC. (2007b). *IPCC fourth assessment report: Climate change 2007 (AR4): The physical science basis*. Cambridge: Cambridge University Press.
- Karamihas, S. (2004). Assessment of profiler performance for construction quality control with simulated profilograph index. *Transportation Research Record: Journal of the Transportation Research Board*, 1900, 12–18.
- Lee, C. Y.-H. (2010). *A probabilistic approach to the life-cycle cost assessment of preventive maintenance strategies on flexible pavements*. Ph.D. Dissertation, University of California, Davis, Davis, CA.
- Lee, I.-S. (2013). *Approaches to life cycle inventory development for sustainable highway infrastructure: Protocol development, regionalization, and new inventories*. Ph.D. Dissertation, University of California, Davis, Davis, California, United States.

- Lidicker, J., Sathaye, N., Madanat, S., & Horvath, A. (2013). Pavement resurfacing policy for minimization of life-cycle costs and greenhouse gas emissions. *Journal of Infrastructure Systems*, 19, 129–137.
- Lu, Q., & Harvey, J. T. (2006). Characterization of truck traffic in California for mechanistic-empirical design. *Transportation Research Record*, 1945, 61–72.
- Lutsey, N. (2008). Prioritizing climate change mitigation alternatives: Comparing transportation technologies to options in other sectors. Ph.D. Dissertation, University of California, Davis, Davis, CA.
- Marceau, M. L., Nisbet, M. A., & VanGeem, M. G. (2006). *Life cycle inventory of Portland Cement Manufacture*. SN2095b. Skokie: Portland Cement Association.
- National Renewable Energy Laboratory. (2011). U.S. life cycle inventory database. Golden: National Renewable Energy Laboratory. Retrieved from <http://www.nrel.gov/lci/>
- OECD. (1998). *Dynamic interaction between vehicles and infrastructure experiment (DIVINE) technical report*. DSTI/DOT/RTR/IR6(98)1/FINAL. Paris: Organisation for Economic Co-operation and Development.
- Rijkswaterstaat. (2012). *DuboCalc*. LA Utrecht, The Netherlands. Retrieved from [http://www.rijkswaterstaat.nl/zakelijk/duurzaam/duurzaam\\_inkopen/duurzaamheid\\_bij\\_contracten\\_en\\_aanbestedingen/dubocalc/](http://www.rijkswaterstaat.nl/zakelijk/duurzaam/duurzaam_inkopen/duurzaamheid_bij_contracten_en_aanbestedingen/dubocalc/)
- Santero, N. J., Masanet, E., & Horvath, A. (2011a). Life-cycle assessment of pavements Part II: Filling the research gaps. *Resources, Conservation and Recycling*, 55, 810–818.
- Santero, N. J., Masanet, E., & Horvath, A. (2011b). Life-cycle assessment of pavements. Part I: Critical review. *Resources, Conservation and Recycling*, 55, 801–809.
- Shahin, M. Y. (2005). *Pavement management for airports, roads, and parking lots* (2nd ed.). New York: Springer Science + Business Media, LLC,
- Sinha, K. C., Labi, S., Rodriguez, M., Tine, G. U., & Dutta, R. (2005). *Procedures for the estimation of pavement and bridge preservation costs for fiscal planning and programming*. FHWA/IN/JTRP-2005/17. West Lafayette: Department of Transportation and Purdue University.
- Smith, K., Titus-Glover, L., Darter, M., Von Quintus, H., Stubstad, R., & Scofield, L. (2005). Cost-benefit analysis of continuous pavement preservation design strategies versus reconstruction. *Transportation Research Record: Journal of the Transportation Research Board*, 1933, 83–93.
- Stripple, H. (1998). *Life cycle assessment of road* (Swedish). B1210. Stockholm: Swedish Environmental Research Institute (IVL).
- Swiss Centre for Life Cycle Inventories. (2011). *EcoInvent*. Dubendorf: Swiss Centre for Life Cycle Inventories.
- Transportation Research Board. (2010). *Highway capacity manual 2010*. Washington, D.C.: Transportation Research Board.
- U.S. Environmental Protection Agency. (2006). *Life cycle assessment: Principles and practices*. Washington, D.C.: U.S. Environmental Protection Agency.
- U.S. Environmental Protection Agency. (2010). *MOVES2010a user guide*. EPA-420-B-10-036. Washington, D.C.: U.S. Environmental Protection Agency.
- U.S. Environmental Protection Agency. (2012). *Tool for the reduction and assessment of chemical and other environmental impacts (TRACI)*. S-10637-OP-1-0. Washington, D.C.: U.S. Environmental Protection Agency.
- U.S. Environmental Protection Agency. (2013). *Inventory of U.S. greenhouse gas emissions and Sinks: 1990–2011*. Washington, D.C.: U.S. Environmental Protection Agency.
- Wang, T., Lee, I.-S., Harvey, J., Kendall, A., Lee, E. B., & Kim, C. (2012a). *UCPRC life cycle assessment methodology and initial case studies on energy consumption and GHG emissions for CAPM treatments with different rolling resistance*. UCPRC-RR-2012-02. Davis and Richmond: University of California Pavement Research Center (UCPRC).
- Wang, T., Lee, I. S., Kendall, A., Harvey, J., Lee, E. B., & Kim, C. (2012b). Life cycle energy consumption and GHG emission from pavement rehabilitation with different rolling resistance. *Journal of Cleaner Production*, 33, 86–96.

- Wang, T., Harvey, J., & Kendall, A. (2014). Reducing greenhouse gas emissions through strategic management of highway pavement roughness. *Environmental Research Letters* 9, 034007.
- Zaabar, I. & Chatti, K. (2010). Calibration of HDM-4 models for estimating the effect of pavement roughness on fuel consumption for US conditions. *Transportation Research Record*, 2155, 105–116.
- Zhang, H., Keoleian, G. A., Lepech, M. D., & Kendall, A. (2010). Life-cycle optimization of pavement overlay systems. *Journal of Infrastructure Systems*, 16, 310–322.

# Chapter 3

## The Product Process Service Life Cycle Assessment Framework to Estimate GHG Emissions for Highways

Amlan Mukherjee and Darrell Cass

**Abstract** This chapter introduces readers to the Product Process Service (PPS) Life Cycle Assessment (LCA) framework. This framework is founded in principals of pavement life cycle assessment and provides the basis for tools that can aid decision-makers in assessing pavement life cycle Greenhouse Gas (GHG) emissions. The chapter will discuss methodologies involved in the data collection process, emissions calculation and project inventory development that support the PPS framework.

### 3.1 Introduction

The construction sector accounts for 131 million metric tons of CO<sub>2</sub> equivalents (Mmt CO<sub>2</sub> equivalent) (EPA 2006). GHG emissions from constructing and rehabilitating highway infrastructure make up 13.22 % of the emissions in the construction sector (Truitt 2009). As the challenges posed by climate change mount, jurisdictions are considering strategies to reduce GHG emissions. At the state level, there has been a movement among Departments of Transportation (DOT) towards monitoring and reduction of GHG emissions of DOT operations. For example, California has legislatively mandated a reduction in emissions (CEPA 2006), Michigan and Washington are investigating the monitoring and reduction of GHG emissions in highway construction operations (MDOT 2011; WashDOT 2010). Other states are gravitating towards a broader emphasis on sustainability in transportation, with increasing focus on context sensitive solutions and livability.

---

A. Mukherjee (✉) · D. Cass  
Department of Civil and Environmental Engineering, Michigan Technological University,  
Houghton, MI 49931, USA  
e-mail: amlan@mtu.edu

D. Cass  
e-mail: Darrell.Cass@state.mn.us

*Present Address:*

D. Cass  
MnDOT, Metro State Aid 1500 W. County Road B-2, Roseville, MN 55113-3174, USA

At the Federal level there has been similar efforts with the Green Highways Partnership as well as a recently funded effort by the Federal Highway Administration (FHWA) investigating sustainable pavements (FHWA 2011). Unfortunately, the current state of knowledge in the field, that advises the development of assessment tools, is incomplete. The current body of work exhibits methodological deficiencies and incompatibilities that serve as barriers to the widespread utilization of LCA by pavement engineers and policy makers (Santero 2010).

Rating systems and LCA based approaches are both considered acceptable, although each has its limitations. Rating systems such as Green Roads™ (Muench et al. 2011) tend to be based on subjective estimates that prescribe best practices. LCA approaches on the other hand remain difficult. While the International Standards Organization (ISO) has developed the principles, framework, and guidelines necessary for conducting an LCA (ISO 2006a, b) there are few pavement life cycle inventories available and fundamental differences yet remain on how the goal and scope of an LCA are developed by researchers—particularly in the establishment of system boundaries and appropriate functional units.

This chapter outlines a study that developed and implemented a project based life cycle framework that can be used to estimate the carbon footprint for typical construction work items found in reconstruction, rehabilitation and Capital Preventive Maintenance (CPM) projects. The framework applies existing life cycle assessment methods and inventories using data collected from 14 highway construction, rehabilitation and maintenance projects in the State of Michigan. The carbon footprint for each of the projects was calculated in terms of CO<sub>2</sub> equivalents of GHG emissions. The primary emissions include life cycle emissions of products and processes involved in the raw material acquisition and manufacturing phase, and the pavement construction phase. The secondary emissions include emissions due to vehicular use, and maintenance operations during the service life of the pavements. The vehicular use emissions were estimated using the EPA MOVES traffic simulator, and pavement maintenance schedules were estimated using observed pavement performance data.

The two main contributions of the study are: (i) a method to calculate project level construction emission metrics was developed and illustrated using the observed projects, and (ii) a web based tool, the Project Emission Estimator (PE-2), was developed based on the emissions calculated from the observed project. PE-2 includes an emission estimator tool that can be used to benchmark GHG life cycle emissions for highway reconstruction, rehabilitation and preventive maintenance projects. The study also identified, ways of implementing the proposed framework within MDOT to help reduce the CO<sub>2</sub> footprint of highway construction projects. Ultimately the goal of the project is to provide operational and strategic guidelines to contractors and agencies to reduce GHG emissions associated with highway lifecycle phases. As the tool is project based in nature, it can also be applied to non-trunk road and airfield construction.

The chapter summarizes research that has been published in three peer-reviewed journals (Cass and Mukherjee 2011; Mukherjee and Cass 2012; Mukherjee et al. 2013).

## 3.2 Background: LCA Frameworks and Tools for Pavements

A LCA study involves the following steps: (i) development of goal and scope of the study, (ii) development of an exhaustive inventory of all energy and material inputs and the environmental outputs and emissions associated with each life cycle phase, (iii) analysis of relative impacts of specific identified materials or processes, and (iv) development of an appropriate interpretation of the analysis to support policy and decision-making. This “cradle-to-grave” accounting process ensures that all the environmental burdens associated with each of the life cycle phases are accounted for, and the most crucial impacts identified for mitigation. The process accounts for the inputs of raw materials and energy, and environmental outputs through all the life cycle phases of a product or process. The ISO have developed the general principles, framework, and guidelines necessary for conducting an LCA (ISO 2006a, b).

A pavement LCA accounts for the emissions from (i) the mining, manufacturing and production of the material products (materials and equipment) used to construct the pavement, (ii) the processes involved during the construction and maintenance of the pavement, and (iii) the service life/use phase of the pavement. The life cycle emissions of the pavement section can be estimated by summing up the emissions for each of these construction, maintenance and reconstruction projects, and the cumulative vehicular emissions during the service life of the pavements. When considering the project emissions, the life cycle emissions of all products, processes and services involved in the construction project are considered.

Pavement LCAs take advantage of existing sector-wide life cycle inventories and tools. Examples include the National Renewable Energy Laboratory NREL inventory—a database of individual gate-to-gate, cradle-to-gate and cradle-to-grave accounting of the energy and material flows into and out of the environment associated with producing a material, component, or assembly in the US (NREL 2009); input-output LCA tools such as the Environmental Input Output-Life Cycle Assessment; and process LCA tools such as SimaPro (PRe’Consultants 2009). However, there was a need to develop specific LCA methodology that lays down consistent framework pertaining to system boundaries and functional units as they apply to pavements. This motivated the University of California Pavement Research Center (UCPRC) and the University of California Institute of Transportation Studies to organize a pavement life cycle assessment workshop where the Pavement LCA guidelines document (UCPRC 2010a, b) was developed. It outlines the framework, system boundary assumptions, and assessment of data models and documentation requirements, along with a detailed pavement LCA checklist. At present, this provides a common starting point for pavement LCA frameworks, tools and inventories.

Recently, Santero et al. (2011a, b) surveyed currently available pavement LCA tools including pavement specific inventories that can be used to assess pavement life cycle emissions (Table 3.1). The survey also highlights the life cycle phases that



**Table 3.1** Source type fraction methodology

Source type ID	Source type name	HPMS vehicle class	HPMSV typeID	HPMSV type name
11	Motorcycle	1	10	Motorcycles
21	Passenger car	2	20	Passenger cars
31	Passenger truck	3	30	Other 2 axle-4 tire vehicles
32	Light commercial truck	3	30	Other 2 axle-4 tire vehicles
41	Intercity bus	4	40	Buses
42	Transit bus	4	40	Buses
43	School bus	4	40	Buses
51	Refuse truck	6	50	Single unit trucks
52	Single unit short-haul truck	5,6,7	50	Single unit trucks
53	Single unit long-haul truck	5, 6, 7	50	Single unit trucks
54	Motor home	5	50	Single unit trucks
61	Combination short-haul truck	8, 9, 10, 11, 12, 13	60	Combination trucks
HPMS class	Source types	Variable for fraction of HPMS class	Source type	Equation
1	11	x1	11=	x1
2	21	x2	21=	x2
3	31,32	x3	31=	x3/2
4	41,42,43	x4	32=	x3/2
5	52,53,54	x5	41=	Not used in rural
6	51,52,53	x6	42=	Not used in rural
7	52,53	x7	43=	x4
8	61,62	x8	51=	x6/3
9	61,63	x9	52=	$x5/3 + x6/3 + x7/2$
10	61,64	x10	53=	$x5/3 + x6/3 + x7/2$
11	61,65	x11	54=	x5/3
12	61,66	x12	61=	$(x8 + x9 + x10 + x11 + x12 + x13)/2$
13	61,67	x13	62=	$(x8 + x9 + x10 + x11 + x12 + x13)/2$

MOVES inputs must sum to 1

each of the tools addresses. Most of the tools (including CHANGER (IRF 2011), PaLATE (2004), asPECT (2010)) focus on the material acquisition/extraction impacts and equipment emissions.

The theoretical underpinning of the LCA framework presented in this chapter and its implementation in PE-2 (Mukherjee and Cass 2011) is based in the pavement LCA framework developed at the UCPRC workshop. It integrates emission factors and inventories from PaLATE, EIO-LCA, GreenDOT (Gallivan 2010), and EPA equipment and traffic emissions data, besides including upstream manufacturing of fuel combusted in equipment, on-highway transportation impacts, off-road transportation impacts, upstream manufacturing impacts of construction equipment, off-road equipment impacts, and batch plant and secondary materials processing impacts. In addition, PE-2 is one of the few systems that recognize the very significant role of the use phase or service life in pavement life cycle emissions. There is limited investigation of the role of pavement vehicle interaction, surface characteristics and albedo on pavement life cycle emissions.

### ***3.2.1 Survey of Available Tools***

Many of the currently available tools to assess the sustainability of pavements are based on LCA methods as discussed above. The rest of them are primarily point based rating systems that award points favoring specific construction practices, design and material choices. While such systems are easier to adopt by contractors and practicing engineers, they tend to be prescriptive in valuing specific material and design choices. The distribution of points across different award categories also tends to be subjective, disregarding context specific pavement performance. LCA and point based approaches are not mutually exclusive as point based systems tend to encourage the use of LCA as a best practice in choosing alternatives.

Based on their utility, the tools can be classified into one of the following: GHG emission calculators (for one or more pavement life cycle phases); or point-based tools that are either subjective or based on limited quantitative assessment. Systems such as SGEC, SMAQMD, GreenDOT, and e-Calc emphasize the measurement and reduction of GHG emissions due to construction and operations of state DOTs. PE-2 can be classified in this category. It provides a user-friendly web-based tool that can be applied to estimate life cycle emissions of the materials and equipment being used on a project. The targeted users of such systems are state agencies and highway construction stakeholders such as contractors.

Meanwhile, states like Illinois and New York have gravitated towards a broader emphasis on sustainability in transportation, with increasing focus on context sensitive solutions and livability. This has motivated the development of tools such as GreenRoads<sup>TM</sup>, GreenLITES and I-LAST that use a point-based system to support best practices that emphasize the operational and societal dimensions of sustainability. GreenRoads<sup>TM</sup> is conceptually similar to the Leadership for Energy and Environmental Design (LEED) rating standards for building construction.

It assesses sustainability for roadway construction by considering factors such as sustainable alignment, materials and resources, storm water management, energy and environmental control, impact of construction activities and innovation in design process. Promotion of sustainability along each of these dimensions is awarded with a specified number of credits and GreenRoads™ standard level from 36 total possible credits.

At the federal level, the Sustainable Highways Self-Evaluation Tool is a point based rating system that was developed by the FHWA (2011). It attempts to assess sustainability aspects of highway and other roadway projects and programs using a self-evaluated scorecard. Points are awarded to projects that reduce GHG emission throughout the project life cycle by reducing fossil fuel use, having off-road equipment meeting Tier 4 standards, and encouraging the use of recycled materials. It recognizes LCA approaches and other strategies to assess life cycle GHG emissions thus encouraging the use of LCA tools.

In summary, while there has been significant development of pavement LCA methodology, and the development of various assessment tools, few have found universal appeal. Given the current state of knowledge, this chapter introduces the PPS-LCA framework and its web-based implementation, PE-2, that builds on and extends the current state of knowledge.

### 3.3 Product, Process, Service Pavement LCA Framework

This research effort that this chapter is based on extends LCA methods to develop and implement a *project based* life cycle framework and methodology to benchmark, monitor and reduce life cycle emissions for pavement construction projects. This approach addresses various problems with conflicting system boundaries and choice of appropriate functional units. To start with, it does not aim to use LCAs to compare and contrast alternative pavement materials. Instead, it shifts the focus of the discussion to improving all round decision-making aimed at reducing GHG emissions of the products, processes and services that define the life cycle of a highway section regardless of pavement type.

The life of a pavement section is defined as the interval between consecutive major pavement reconstruction projects. This interval is usually punctuated by a few maintenance and rehabilitation projects. The project-based approach estimates the life cycle emissions of the pavement section by summing up the emissions for each of these construction, maintenance and reconstruction projects, and the cumulative vehicular emissions during service life of the pavements. When considering the project emissions, the life cycle emissions of all products and processes involved in the construction project are considered. This allows the consideration of highway sections as material products that provide important transportation services, within the context of various decision-making processes.

Most importantly, in each case it involves the consideration of relevant stakeholder interests. Hence, the usefulness of particular products at different points in

the pavement life cycle may differ given the levels of service provided, and the decision-making processes in place. This also shifts the discussion from greater suitability of a particular pavement type for a project to reducing the overall project emissions. It also provides incentives to contractors and DOT decision-makers to reduce life cycle emissions through consideration of innovative approaches in construction management, and pavement maintenance schedule management.

The goal of the proposed framework is as follows:

1. Provide a method to calculate project GHG emissions;
2. Develop an inventory of construction emission metrics that can be used to benchmark project emissions;
3. Provide a tool that can estimate emissions for future projects, and
4. Serve as a platform for identifying emission reduction best practices.

The intended users of this framework are state agencies, and construction contractors. It is expected that an implementation of this framework will allow them to calculate project emissions, and identify ways of reducing project GHG emissions. Agencies can use the framework to get a life cycle perspective of emissions from specific highway sections, including observed emissions from construction, maintenance, rehabilitation projects, and an estimate of emissions during the use phase. Contractors can use it to estimate GHG emissions for specific construction operations—particularly with the goal of identifying alternative materials or improvements in construction processes to reduce their emissions. In turn, this will encourage the adoption of low emission products and techniques into practice, thus indirectly including other stakeholders such as material suppliers and equipment manufacturers.

The approach takes advantage of existing methods of calculating GHG emissions, while emphasizing the collection of project data through the construction phase and the service life (use phase) of the pavement. It particularly accounts for the emissions from (i) the mining, manufacturing and production of the material products (materials and equipment) used to construct the pavement, (ii) the processes involved during the construction and maintenance of the pavement, and (iii) the service life/use phase of the pavement. In doing so, the research builds on methods and metrics in the literature that apply LCA to different stages of the pavement's life. Based on the objectives of the proposed framework, the boundaries of the system being studied in this framework can be described as a function of the product, process and service components.

### ***3.3.1 Product components***

This considers the impact of the pavement product itself—specifically accounting for the all pavement materials and equipment that contribute to the construction of the highway section. All materials listed in project pay items as per a specific agency (such as a state DOT) specifications, are accounted for, except materials that

are associated with bridge construction. For each of the materials, emissions for the mining and manufacturing phase are accounted for. In addition, the emissions of transporting the materials to the construction site are included. Both virgin materials and (where reported) recycled materials are accounted for. For example, recycled aggregate is considered explicitly. All equipment used during the construction and maintenance operations is accounted for, as well. For each equipment type, total energy use (gallons of fuel) on the construction site (as a function of total hours of usage) is accounted for. In addition, a fraction of the emissions from manufacturing of the equipment, proportional to the number of hours of use on a particular project is included. The product components are limited to involve only materials and equipment directly associated with the stakeholder's decision-making processes.

### ***3.3.2 Process components***

The process includes two components—the processes on site that are directly involved in the highway construction and maintenance operations, (e.g., construction schedule and operation design) and the processes that directly influence decisions of long-term pavement behavior (e.g., determination of maintenance schedules). The process components are limited to involve only processes that directly involve the stakeholder decision-making processes.

### ***3.3.3 Service life components***

Service life components of pavements can be quite difficult to determine and even more difficult to estimate. Therefore, a traffic simulation environment MOVES (EPA U.S.E.P.A 2010) is used to estimate use phase emissions due to on-road vehicular traffic. Excess emissions due to traffic delays and reduced speeds in construction zones are also considered. While this is a very limited consideration of the service life of pavements, it provides agency stakeholders a reasonable baseline to benchmark projects.

The product and process data will be directly observed from project sites, while the service phase data are estimated using traffic simulations. The pavement life cycle phases that this framework involves are:

1. Material Acquisition/Extraction Impacts (Product);
2. Upstream Manufacturing Impacts of Fuel Combusted in Equipment (Product);
3. Upstream Manufacturing Impacts of the Construction Equipment (Product);
4. On-Highway Transportation Impacts (Process);
5. Off-Road Transportation Impacts (Process);
6. Off-Road Equipment Impacts (Process);
7. Batch Plant and Secondary Material Processing Impacts (Process);

8. Construction Schedule (Process);
9. On-Road Vehicular Emissions (Service), and
10. Long Term Pavement Maintenance Schedules and Performance (Service).

The functional unit ‘emissions per lane mile’ has been used widely in the literature. However, this unit has various limitations—most importantly, it does not scale in any uniform fashion as the number of lane miles increase. One reason is that the length of shoulder does not increase in the same way as the number of lane miles increase. In addition, there is an impact of statistical smoothing as the denominator increases. As the proposed framework accounts for multiple pavement functionalities, it is not suitable as the *only* functional unit. Some of the other functionalities include:

1. Product performance (e.g. differences in emissions of alternative and/or recycled materials compared to virgin materials);
2. Process performance (e.g. savings in emissions through appropriate construction site layout, schedule and operation design), and
3. Services performance (e.g. increased emissions due to construction zone delays and emissions for different maintenance schedules and pavement life cycles).

In addition, it is important to note that while this framework is inspired by LCA approaches, its aim is not to compare products and processes—but to instead provide decision-support to strategically reduce GHG emissions for each of these functionalities. Hence, most of the units discussed in this section are intended to be decision metrics rather than pure functional units. Therefore, the choice of an appropriate functional unit/metric depends on the decision being considered. Various functional units have been discussed in a later section.

### 3.4 Hybrid Life Cycle Assessment Methodology

Applying LCA to study the environmental effects of products or processes requires systematic accounting for the different stages through the life cycle. The life cycle phases considered are the materials extraction phase, manufacturing/production stage, the use phase and the ultimate end-of-life/disposal and recycling phase. All inputs and outputs into a product or process are accounted for, and the environmental impacts of each are directly calculated to determine the total life cycle environmental impacts. This chapter focuses on using this method to calculate the GHG emissions—one component of all environmental impacts calculated by an LCA.

There are two ways to conduct an LCA—using an input-output based LCA, or a process based LCA. Economic input-output based LCAs are based on economic transactions and resource interactions between an exhaustive set of economic sectors. The system wide use of resources, as measured by economic input and output across all related sectors, is used as an indicator of emissions from industries in that sector. Input-output models identify emissions that are immediately related

to the product and/or process at hand, as well as emissions from related economic activity across sectors. Process-based LCA practitioners on the other hand, isolate processes using well-defined system boundaries and calculate direct emissions of all activities within the defined boundary. The inputs (materials and energy) along with the outputs (emissions) from each step in the product or process life cycle are itemized and accounted for.

A critical difference between these two methods is that input-output LCAs take into account multiple economy-wide interactions, attempting to provide a comprehensive assessment, while process LCAs tend to be detailed assessments of specific industrial processes that can be easily identified and isolated. All interactions defining the chain of specific processes that comprise the material extraction and production phase are difficult to account for. For example, the transportation impacts from raw material extraction sites to the manufacturing/production facility may fall beyond the system boundary of the process LCA and be excluded, and be difficult to estimate. In such cases, sector wide input-output LCAs are better suited for estimating average emissions associated with such system wide interactions.

A choice between one or the other LCA often involves trade-offs between accuracy and scope, and is sometimes dictated by availability and measurability of data sources. The advantages and disadvantages of these two methods are outlined in previous work (Hendrickson et al. 1997).

In the research effort that this chapter is based on, a hybrid LCA method was adopted. Hybrid LCAs have been previously considered for application to construction processes (Bilec et al. 2006). The method takes advantage of the structure of a process LCA to define the system boundaries of a construction process, and identify and inventory the associated resource (materials and equipment) inputs, and emission outputs. In order to estimate the GHG for all the materials and equipment inputs, an input-output and/or process LCA tool are used taking advantage of the most recent emission factors that have been reported in the process LCA literature, when applicable, as well as maximizing the advantages of an input-output LCA. In effect, an integrated hybrid LCA model is used to represent the life cycle impacts of the construction projects. In the model, the GHG emissions are quantified as a function of the construction and vehicle operations in terms of material/fuel usage.

The emission factors used in this chapter are from process LCAs reported in literature. They have been primarily from the Stripple (Stripple 2001), Athena (2006) and NREL (2009) inventories. These emission factors are usually expressed as tons of CO<sub>2</sub> equivalents per unit weight or volume. Therefore, given a bulk volume or weight of a material use on a particular project, the emissions can be calculated by using the emission factors.

The Economic Input Output-Life Cycle Assessment (EIO-LCA) is also used in the hybrid model. It is a model that defines the scope and number of environmental effects quantified in a LCA. Developed at Carnegie Mellon University (Hendrickson et al. 2006) it estimates the economic contribution, resource requirements and environmental emissions for a particular product, service, or activity. The model attempts to capture all the requirements to produce a product, service, or

activity, only for the life cycle stages of extraction/mining, transportation, and manufacturing. Construction activity, operation and maintenance activities, and end-of-life/disposal impacts of products are not accounted for in the EIO-LCA model, and have to be determined independently. EIO-LCA has been used for conducting LCAs to assess the sustainability of different kinds of pavements. For this study, EIO-LCA was used to account for manufacturing of the materials used in each project along with the manufacturing impacts of the fuel and equipment to be used in the construction project.

The usefulness of the EIO-LCA model is dependent on the accuracy of the material and equipment inventories developed for each pavement design and construction operation type. In addition, the outputs are reliant on the economic input of the identified materials and equipment in US\$ and based on the 2002 US Economy. Average cost for each material or item varies by region and the costs reported in the contracts are agency costs (cost to the DOT rather than cost of material production), which are inapplicable to EIO-LCA studies. Therefore, material prices must be isolated from agency's cost. It is important to use material prices (rather than estimated cost to the agency) that were reflected in the project to obtain the most accurate results in EIO-LCA. This can be used to investigate the impact of variability in pricing due to availability of regional materials on life cycle emissions. For this chapter, national average material prices were obtained through RS Means data (2009) (MDOT 2009) and then converted to 2002 US\$ using applicable cost indexes. (Cost indices were calculated using a base of 100 inch 1913, as per Engineering News Record data, e.g. 2010 cost index is 183.5).

### 3.5 Data Collection

This section describes the method used to collect highway construction data for the development of inventories of material and equipment associated with a project's product process and service components. Product and process data was collected directly from construction sites, while service data was simulated using highway characteristics and traffic data.

Construction product and process data collection led to the development of material and equipment inventories, which represent the construction and rehabilitation process. New construction, re-construction and different maintenance operations were considered. The primary challenge in collecting this data was eliciting co-operation and collaboration from project engineers, contractors and sub-contractors on site. Hence, it was imperative to take advantage of existing reporting methods, thus minimizing the burden of reporting. In addition, data were collected through direct field observation by researchers. For the service component, the Motor Vehicle Emission Simulator (MOVES) simulation was used to estimate on-highway vehicle emissions throughout the service life of the pavement. Results from the simulation were also used to investigate additional emissions due to



construction work zone delays. The MOVES simulator was developed by the United States Environmental Protection Agency (US EPA) (EPA 2010b).

MDOT requires the use of software called FieldManager™, a construction management and reporting software created by InfoTech Inc. (InfoTech 2009) on all their construction and rehabilitation contracts. The software maintains electronic reports of MDOT Inspector's Daily Records (IDR). Inspectors (on behalf of MDOT) use FieldManager™ to record, on a daily basis, information regarding general site conditions, contractor personnel and equipment on site, and quantities of different material installed on site. FieldManager™ was chosen for this research to take advantage of MDOT's existing process for tracking and monitoring all their construction and rehabilitation contracts. Hence, this method takes advantage of current field expertise, and reporting practices to support the data collection procedure. The IDRs were directly collected from the FieldManager™ database and used to accurately account for the product and process data collected for each of the projects surveyed. In the next sub-sections, each data category is explained in detail.

### ***3.5.1 Product Data***

Materials used on the construction site were recorded using the IDR, by tracking progress made on each pay item as specified in the construction contract. The location, station information and quantities of materials associated with each item installed were stored. The data were used to maintain an as-built record of procured and installed material. The collected data are considered highly accurate, as the contractors were paid based on these records. Using as-built quantities in the calculation of life cycle impacts and emissions is significantly more representative of project impacts compared to similar calculations done with estimated quantities.

Product data allowing for the estimation of impacts associated with the manufacturing of construction equipment were also collected. First, the purchasing price of general categories of construction equipment being used on the project was determined. The total impact for producing the machinery was then determined using three types of data pertaining to the equipment:

- Purchasing value of equipment (from online equipment vendors);
- Useful life of equipment (CAT 1999; Peurifoy 2002), and
- Hours used on specific project (from FieldManager™).

Using this information, the impacts were estimated for each individual piece of machinery, and then broken down further by applying the portion of the machinery's life that was reflected in the actual project. This was done using the number of hours used/total useful life ratio. For example, if the expected life of equipment is 10,000 h, and the number of usage hours on a particular project is 1,200 h, then only three twenty-fifths of the manufacturing impact of that equipment is considered for the project.

The development of this inventory was crucial to this project. It also has long-term implications. When available to other researchers, it can support the investigation of questions beyond the scope of this study but particularly relevant to the topic. It is expected in the long-run MDOT will continue to use this method to collect data across various construction projects. The data collected across similar and different construction projects can then be analyzed by cross classifying across pavement designs, construction operations and site-specific conditions to highlight sensitivity of impacts and emissions to local and regional variables.

The emissions from these material inventories were estimated from methods described in the section titled Materials Emissions.

### ***3.5.2 Process Data***

The contractor equipment inputs in the IDR were critical to quantifying project construction equipment emissions. Recent studies have shown that energy use and emissions of construction processes are primarily due to construction equipment use, which can account for 50 % of most types of emissions. Also, equipment larger than 175 hp made prior to 1996 tend to have higher emissions than more recent models (Guggemos and Horvath 2006). Therefore, data were collected to account for the use of equipment on construction operations. While the type and quality of construction equipment influence project emissions, the design of the operations—in particular travel distances on site—also influence project emissions. In this chapter, the emphasis has been on studying the processes that define the construction operations—with the goal of encouraging emission reduction through increased efficiency on construction sites.

In taking full advantage of fields specified in the IDR, inspectors were requested to identify equipment present on-site, how long the equipment worked, and the operation the equipment was performing. Inspectors recorded: (i) equipment characteristics such as model year, gross vehicle weight and mileage on the vehicle (Henceforth all this information is referred to as equipment type for brevity); and (ii) activity characteristics such as number of trips, one way distance, and return distance. Due to lack of complete cooperation from the inspectors, the data collected through the inspector reports were incomplete. Appropriate assumptions (explained later in the chapter) were made to account for the missing data. For more accurate assessment, there may be a need to standardize the reporting procedure for Inspectors when using FieldManager™. Information collected through FieldManager™ was also supplemented with information collected in collaboration with contractors. This included information regarding equipment specifics needed to calculate equipment emissions—such as the equipment model, year, make, type of fuel used (sulfur content) and engine type. In some cases, contractors were already tracking their equipment usage to monitor efficiency, and were willing to share the information. This information is highlighted in PE-2. Information collected from the contractor was used to support any assumptions made and the information

recorded in FieldManager™ IDR when applicable. In the future, if equipment emissions are to be monitored by MDOT, reporting standards for all inspectors must be developed for uniform reporting of on-site equipment use. In addition, it is expected that collaboration between agencies and contractors will increase so that relevant data can be correctly and exhaustively reported.

On-site travel distance data are an indicator of construction operation design efficiency. For example, inefficient design can result in longer operation cycle times as well as longer travel distances from batch plant location. Some of this data were obtained directly from on-site observation. In addition, material-testing orders provided by MDOT were used to calculate the distances travelled in transporting materials to the construction site. Researchers were able to map the site layout with respect to material stockpiles, batch plants, suppliers, etc.

The following outlines the data types collected to accurately account for on-site travel from hauling equipment:

1. Equipment Descriptions are categorized into generalized construction equipment categories (i.e. dozer, excavator, etc.);
2. Generalized equipment categories are assigned a fuel consumption rate and an hours per day operating rate, and
3. Quantify fuel used/combusted in equipment.

This process data also include travel distances and number of trips for the hauling equipment. This data were obtained from on-site observation material testing orders. To account for combustion process emissions, carbon content of diesel fuel was used and obtained from the US EPA (EPA 2008).

The data obtained from material testing orders were used to estimate emissions from hauling equipment traveling to and from material stockpiles and pits to provide the materials that make up the pavement designs. This data included the travel distances from the suppliers to site, from stockpiles and batch plants to site, and from stockpiles/suppliers to batch plants. The testing orders provided addresses of material suppliers along with limited descriptions of material stockpiles. Locations of these stockpiles were also obtained through correspondence with the contractors.

The following outlines data types collected to account for to-site travel from hauling equipment:

1. Site layout maps to estimate distances from material suppliers to site or batch plant locations;
2. Number of trips taken from suppliers or stock pit, and
3. Total travel distances on-site.

Emissions from equipment activity and to site transport are estimated using the methodology outlined in Equipment Emissions.

Additionally, the construction schedule process data were collected to investigate net increased emissions due to schedule delays. Particularly, two schedules were analyzed in performing this analysis; as-planned and as-built. Original progress schedules (MDOT Form 1130) were used to outline the as-planned schedule. The resource allocation for the as-planned schedule—particularly important for

calculation of as-planned production rates—was calculated from the project proposal’s estimate. The progress schedule outlines construction activities along with proposed starting and end dates for each activity. FieldManager™ was used to develop the as-built resource loaded schedule, by allocating pay items to activities outlined in the progress schedule and assessing the actual productivity (material and equipment usage) depicted in FieldManager™.

### 3.5.3 Service Data

Life cycle performance of highway sections plays a critical role in reducing GHG emissions. Long-life pavements that require little or no major rehabilitation promise to lower the overall life cycle GHG emissions. Pavements with minimal rehabilitation and maintenance can lower the overall life cycle GHG emissions. As part of this study, pavement condition and historical maintenance data are used to estimate maintenance schedules and overall pavement life cycle definitions.

In addition, emissions associated with the service provided by the pavement (referred to as the use phase emissions) must also be accounted for. The system boundary for the use phase is difficult to define. For the research that this chapter is based on, the scope was limited to emissions due to on-road vehicular traffic use of the pavement. Therefore, the data collected for this component are:

- Maintenance and rehabilitation records for the highway section investigated;
- Pavement condition data such as Distress or IRI measurements before and after maintenance;
- Quantity of material and equipment used for rehabilitating the roadway—this simply accounts for the product and process emissions of the maintenance and rehabilitation operations and are considered as a gross number in this phase;
- Highway traffic characteristics, and
- Emissions due to work zone delays.

It is important to note that, although not considered in this study, vehicle-pavement interaction will also influence life cycle GHG emissions. For example, increased fuel efficiency of vehicles on rigid pavements reduces life GHG emissions (Chatti 2010).

Service data collection lead to limited traffic scenarios that could adequately represent the highway sections investigated. In-use service data associated with highway section are used to estimate on-road vehicle emissions resulting from the service phase of the pavement section. As indicated, the US EPA MOVES model was used for this analysis. Types of service data used in this study are, but not limited to, the following:

- Fuel Composition data;
- Climate data;
- Vehicle Characteristics, and
- Traffic Class Distribution.

It is with these types of service data that the service component of the pavement LCA was assessed.

### ***3.5.4 Data Sources***

Data were collected from the following projects. Each of the projects was classified into four categories: New construction/major construction (R1), Reconstruction (R2), Major rehabilitation (M1), Rehabilitation (M2); based on size and type of the project. The projects that were investigated in this study are (MDOT 2009):

1. Project number 11056-50757 (R1): 3.27 mi of road reconstruction, ramps, culverts and permanent traffic recorders on US-31 northbound and southbound from the Michigan state line northerly to US-12, Berrien County. Alternate 1 is hot mix asphalt road reconstruction and related items and Alternate 2 is concrete road reconstruction and related items. The State DOT invited bids for the reconstruction on two alternative pavement designs; one using HMA and the other using concrete. The project was awarded to a bid that had the lowest life cycle cost, which in the competitive bidding process was the HMA design.
2. Project number 03033-75215 (R2): 6.94 mi of concrete overlay rehabilitation, pavement removal, concrete pavement reconstruction, culvert replacements, signing, pavement markings, median cable barrier installation, rest area demolition and construction, landscaping, concrete deck overlay, and railing replacement on I-196 from 71st street northerly to 118th avenue and on I-196 over 71st street, Allegan County.
3. Project number 44043-79776 (R1): 10.14 mi of concrete pavement and shoulder reconstruction, guardrail and drainage improvements, and bridge rehabilitation of 12 bridges on I-69 from east of M-15 easterly to east of M-24, Genesee and Lapeer Counties.
4. Project number 05071-79647 (R2): 3.00 mi of crack relief, asphalt crack relief layer, reconstruction, crushing and shaping with hot mix asphalt widening, miscellaneous drainage, safety improvements, decorative sidewalk, decorative lights, and tree planting on US-131 from Elder road northerly to M-66 and from north of Dale avenue to south of Division street in the village of Mancelona, Antrim County.
5. Project number 52041-80145 (R1): 3.02 mi of roadway reconstruction and realignment, drainage improvements, guardrail upgrading, and pavement markings on US-41/M-28 from Brown road westerly to the Marquette/Baraga County line, Marquette County.
6. Project number 55011-84193 (R1): 2.02 mi of street reconstruction including excavation, hot mix asphalt pavement, concrete curb and gutter, sidewalk, storm sewer, sanitary sewer, water main, traffic signals, permanent signing,

- pavement marking, and restoration on US-41 from 20th avenue northerly to 48th avenue in the city of Menominee, Menominee County (Data collected from year 1 of 2).
7. Project number 56021-105611 (M1): 4.16 mi of hot mix asphalt cold milling and overlay, joint repairs, shoulder upgrades behind the existing curb and gutter, sidewalk ramp upgrades, and other miscellaneous work on M-20 from west of Meridian road easterly to east of Vance road, Midland County.
  8. Project number 41031-105479 (M1): 0.81 mi of full depth concrete pavement joint and crack repairs on M-37 (Broadmoor Avenue) from north of 60th Street northwesterly to south of 52nd street, in the city of Kentwood, Kent County.
  9. Project number 51021-106248 (M1): 6.83 mi of hot mix asphalt cold milling and resurfacing on M-55 from west of Udell Hills road to west of Cooley bridge, Manistee County.
  10. Project number 02041-106939 (M1): 4.63 mi of concrete pavement repairs, hot mix asphalt cold milling and resurfacing, drainage structure repairs and sidewalk ramps on M-28 from east of Center street easterly to west of the Anna River bridge, in city of Munising, Alger County.
  11. Project number 51012-106238 (M2): 4.35 mi of overband crack filling, micro surfacing, centerline and shoulder corrugations, and pavement markings on US-31 from north of US-10 to south of Hansen road and from north of M-55 to south of M-22, Mason and Manistee Counties.
  12. Project number 11112-106504 (M2): 8.63 mi of transverse and longitudinal joint resealing with isolated transverse crack sealing on US-31 northbound and southbound from M-139 to Napier avenue, Berrien County.
  13. Project number 37014-106474 (M2): 12.76 mi of crack treatment and single course micro surfacing on US-127 from River road northerly to the Isabella/Clare County line, Isabella County.
  14. Project number 83033-106529 (M2): 7.10 mi of overband crack filling and single course micro surfacing on US-131 northbound and southbound from south of Boon road northerly to south of Old US-131, Wexford County.

For each of the above projects the data were collected for product and process components and organized in a database server that is hosted on a web server at Michigan Tech University.

### **3.6 GHG Emissions Calculation Using PPS LCA Methodology**

The three types of data described in the previous section supported the estimation of GHG emissions resulting from the construction and rehabilitation projects investigated. The following methods were used to estimate GHG emissions:

### 3.6.1 Product Component GHG Emissions

To estimate the GHG emissions from the product components using the hybrid LCA approach, researchers used various emission factors. For material acquisition/extraction emission of driving materials, emission factors were obtained from published process LCA data. For example, cement, binder, and aggregates are all represented using emission factors published in literature, and commonly used as representative emission factors for these materials. These factors were converted to represent units used by MDOT. The calculation is based on the amount of CO<sub>2</sub> emissions per unit of material used. Where published emissions could not be accessed, EIO-LCA was used to develop emission factors based on emissions associated with the industry sector that the product was classified under. An example calculation for using EIO-LCA is as follows:

- Material: Pavement Marking Waterborne Paint (gallon);
- EIO-LCA sector and model used: 325510 Paint and Coating Manufacturing represented in the US 2002 National Producer Price Model;
- Using \$1,000 as a baseline to estimate the material's Global Warming Potential (GWP) impact, the metric tons of CO<sub>2</sub> equivalent Emissions per \$1,000 purchased is 0.988;
- The unit price for 2009 for a gallon was US\$83.33. This is converted to a 2002 price using the factor 0.7146 (cost index 2002/cost index 2009 = 128.7/180.1);
- Therefore, if the project is using 500 gallons of pavement marking paint the estimated GHG emissions from producing the material is found to be (500 × 83.33 × 0.7146 × [0.988/1,000] =) 29.476 m CO<sub>2</sub> equivalent.

EIO-LCA was also used to determine impacts from manufacturing the fuel combusted in the construction equipment on site, and impacts associated with manufacturing the machinery utilized on the project. The former was quantified from construction equipment use reports generated from FieldManager™. The latter was estimated by first, determining the purchasing price of generalized construction equipment being used on the project, obtained from equipment vendor's websites. Once the price for the equipment representing the projects was determined, those prices were then converted to 2002 prices using the following formula.

$$EC_{2002} = EC_{2009} \times [1 + r]^n / [1 + i]^n$$

Where EC is the equipment cost,  $n = 6$  years,  $r$  is the discount rate assumed to be 5 %, and  $i$  is the inflation rate assumed to be 3 %.

The total impact for producing the machinery that was used on the projects was then determined using EIO-LCA. EIO-LCA is only capable of estimating the entire machine's impact. Therefore, using the information from EIO-LCA, the impact was broken down for each individual piece of machinery, and then broken down further by applying the portion of the machinery's life reflected in the actual project. This was done using the number of hours used/total useful life ratio. For example, if the

expected life of equipment is 10,000 h, and the number of usage hours on a particular project is 1,200 h, then only three twenty-fifths of the manufacturing impact of that equipment is considered for the project.

### ***3.6.2 Process Component GHG Emissions***

A combination of methods and tools were used to estimate the GHG emissions from process components of the hybrid LCA. It consisted of emissions from transporting materials to site, emissions from distances travelled on site during construction, batch plant emissions and increased emissions associated with delays in construction schedules.

On-Highway transportation impacts were considered by accounting for impacts due to hauling materials from the supplier to-site. Information on supplier locations was obtained from material testing orders procured through MDOT. The locations and distances were mapped using Google Maps. The mode of transportation was assumed an on-highway combination diesel transport truck fully loaded 30 metric tons. The corresponding emissions were calculated to be 0.386 m CO<sub>2</sub>/mi.

The emissions resulting from off-road transport and construction equipment usage was estimated using EPA approved methodologies. The Equipment was generalized based on the following premises:

- Equipment type categories, horsepower (hp), and load factors (% of hp used) classifications were obtained from the California Environmental Quality Act (CEQA) tool for assessing emission for road construction projects (2011);
- Load factors were estimated considering average operation level as a percentage of the engine manufacturer's maximum horsepower rating (CEPA 2010), and
- The same horsepower and load factor classifications were assigned to the equipment types used in the case studies.

Variability in year, make, and model are excluded from this analysis due to lack of adequate current data. The data set classifies the equipment into use types. On-site construction equipment is considered "stationary." Hauling equipment, transporting materials on and off site from stockpiles, batch plants, etc. are considered "hauling". All miscellaneous equipment such as the foreman's pick-up is considered "other". In some cases, division and section identification numbers classify the equipment. These represent the type of work being performed by the equipment. The identification numbers directly relate to division and sections of work outlined in MDOT's Standard Specifications for Construction (MDOT 2003). Analyzing this parameter allows the researcher to assess productivity and GHG emissions based on work type.

Estimated diesel fuel emissions from the equipment were based on fuel consumption. Recent studies have shown that fuel use emission factors have less variability than time-based emission rates (Frey et al. 2010). Therefore, gallons of fuel consumed were estimated using the following formula:



$$\text{Fuel Rate (gal/hr)} = \text{LF} \times \text{TF} \times \text{FF} \times \text{HP}$$

where: LF is load factor, TF is the time factor which was assumed to be 50 min/h in this study. FF is Fuel factor (diesel) and assumed to be 0.04 gal/(hp-hr) (Peurifoy 2011). HP is the average horsepower used for each equipment type. Based on the determination of fuel consumption, three GHG emissions were estimated ( $\text{CO}_2$ ,  $\text{N}_2\text{O}$ , and  $\text{CH}_4$ ) using the following equations:

$$\text{CO}_2 : \text{Emissions (mt)} = \sum_{i=1}^n \text{Fuel}_i \times \text{HC}_i \times \text{C}_i \times \text{FO}_i \times [\text{CO}_2/\text{C}] \text{ (EPA 2008)}$$

Where:  $\text{Fuel}_i$  = Volume of Fuel Type  $i$  Combusted,  $\text{HC}_i$  = Heat Content of Fuel Type  $i$ ,  $\text{CC}_i$  = Carbon Content Coefficient of Fuel Type  $i$ ,  $\text{FO}_i$  = Fraction Oxidized of Fuel Type  $i$ ,  $\text{CO}_2$  (m.w.) = Molecular weight of  $\text{CO}_2$ , C (m.w.) = Molecular Weight of Carbon.

The following values were used in the calculation of  $\text{CO}_2$  emissions and obtained from US EPA's guide on calculating GHG emissions from mobile sources (EPA 2008):

- $\text{HC}_i = 5.825$  mm Btu/barrel;
- $\text{C}_i = 19.95$  kg C/mm Btu;
- $\text{FO}_i = 1.0$ ;
- $\text{CO}_2$  (m.w.) = 44.01, and
- C (m.w.) = 12.01.

$$\text{N}_2\text{O and CH}_4 \text{ Emissions (g)} = \text{Fuel}_i \times \text{EF}_p$$

where:  $\text{Fuel}_i$  = Volume of Fuel Type  $i$  Combusted,  $\text{EF}_p$  = Emission Factor per pollutant type ( $\text{N}_2\text{O}$  or  $\text{CH}_4$ )

The following values were used in the calculation of  $\text{N}_2\text{O}$  and  $\text{CH}_4$  emissions and obtained from the US EPA's guide on calculating GHG emissions from mobile sources (EPA 2008):

$$\text{EF}_{\text{N}_2\text{O}} = 0.26 \text{ g/gal}$$

$$\text{EF}_{\text{CH}_4} = 0.58 \text{ g/gal}$$

After determining the various GHG emissions from equipment types estimated from the case studies, a total  $\text{CO}_2$  equivalent was calculated using the following Global Warming Potential (GWP) multipliers (EPA 2004):

$$\text{GWP}_{\text{N}_2\text{O}} = 296$$

$$\text{GWP}_{\text{CH}_4} = 23$$

This methodology is used to estimate CO<sub>2</sub> emissions from off-road transport and construction equipment usage for each observed project.

An alternative method to calculating on-site transportation emissions is to directly calculate the travel distances and number of trips for the hauling equipment using the site-specific location data directly observed from site. The number of trips is determined from the total amount of material placed on-site (from FieldManager<sup>TM</sup>), and the capacity of the hauling equipment and the design of the construction operation. Given the cycle times for driving operations (such as mainline paving), the volume and the number of trucks in use, the distances traveled to and from the batch plant, and the kind of hauling equipment used, the impacts associated with the equipment use during the operation can be calculated. This is strictly a function of the site design and operation logistics. Hot Mix Asphalt (HMA) hauling trucks were assumed to have a hauling capacity of 28 tons of HMA, and concrete hauling trucks were assumed to have a hauling capacity of 10 cubic yards of concrete.

The following formula establishes the method used to calculate the total distances travelled on-site for a particular scenario in which the batch plant location is placed at the Point of Beginning (POB) of the pavement section, and trucks hauled the concrete back and forth to the points at which it was placed. If the batch plant is located off-site, the additional distance to the POB of pavement section must be added. Assuming there was only one truck equivalent in the placement operation, the length of each truck trip was incremented by the distance that was paved by the volume of concrete carried in the truck. The calculation formulates to an arithmetic progression as follows:

$$D = [x \times n \times (n+1)]/5280$$

where  $D$  is the distance traveled on site in miles,  $x$  is the distance paved per truck trip in feet and  $n$  is the total number of truck trips. The assumption of using a single truck to calculate the number of truck trips is entirely reasonable, as the focus is not on the duration of the operation but only on the distance traveled. The total distance traveled can be used to estimate emissions using one of the various emission calculators described in this chapter.

Batch plant emissions were estimated using emission factors published in literature. The source of the emission factors used can be found in the emission factors table that can be accessed at (Mukherjee et al. 2011). Based on the total tonnage of composite material manufactured in the batch plant, emissions were estimated. Alternative technologies such as Warm-Mix Asphalt (WMA) were not investigated in this study.

The final process component to be analyzed is construction schedules. The motivation behind analyzing construction schedule is to recognize that inefficiencies in the activity scheduling process directly relate to increased construction site emissions. Inappropriate planning can result in delays and rework that in turn increases equipment and material use, thus increasing the total project emissions. Therefore, the as-planned schedule for a particular project that suffered significant

delays was compared to the as-built schedule, using information in FieldManager™, to identify the impact of construction delays on construction emissions.

Equipment usage was estimated based on the number of working days and the assumption of a 10 h working day. A combination of emission factors in the literature based in process LCAs and the Economic Input Output-Life Cycle Assessment (EIO-LCA) was used to estimate the impacts of materials through the life cycle stages of extraction/mining, transportation, and manufacturing. When using EIO-LCA, material costs were obtained through RS Means data (MDOT 2009) and then converted to 2002 US\$ using applicable cost indexes. When using SimaPro, the direct weight of the materials used was considered as inputs.

When assessing equipment emissions, the working days from both as-planned and as-built schedules were identified to establish extra equipment use. The make, model, type, and horsepower characteristics of each type of equipment were identified using fleet information provided from the contractor. Using the following equation, the emissions were estimated for each activity's controlling equipment type.

$$Emissions = O_t \times HP \times C_F \times \varepsilon$$

- Where  $O_t$  = Operating time factor, HP = Rated Horespower,  $C_F$  = Fuel Consumption Rate (gal/(hp\*hr), and  $\varepsilon$  = emission rate (lbs CO<sub>2</sub>/gal)

The following assumptions were made:

- Operating Time Factor was assumed to be 45 min/hr (0.75);
- Working Day = 10 h;
- Fuel Consumption Rate = 0.04 gal/(hp\*hr) (Peurifoy and Oberlender 2002), and
- Emission Rate = 221 bs CO<sub>2</sub>/gallon (EPA 2005).

### 3.6.3 Service Component GHG Emissions

Service component emissions were estimated in two ways:

- Assessment of pavement performance data to estimate the actual pavement maintenance schedules, that define the service life of the pavement, and
- Estimation of vehicle emissions by simulating and modeling vehicle-use scenarios using EPA MOVES model.

In the performance based approach the pavement use phase is defined by outlining the various preventative maintenance strategies that are implemented throughout the life of the highway section. Rehabilitation options are highlighted in MDOT's Capital Preventative Maintenance (CPM) manual (MDOT 2005). However, the time at which these options occur is not explicitly stated. In order to maintain the project-based perspective of this LCA application and account for

regional variations in pavement performance, it is suggested that maintenance schedules be based on historical performance of the pavement sections. This involves investigating historical pavement condition data to determine when rehabilitation strategies are being carried out. MDOT uses the Distress Index (DI) parameter to assess a pavement section's condition. It is a measure of the cracking distresses influencing the pavement's condition. This analysis can prove to be very beneficial in developing regional maintenance schedules that can be used as a guide to assess the environmental impacts of the maintenance phase of the LCA. Additionally, analysis like this can provide the essential timelines needed to define life cycle periods used in LCA. Performance based approaches like these promise to further the investigation of context sensitivity regarding the GHG emissions of highway construction and maintenance operations.

The use phase of the project consists of estimating the CO<sub>2</sub> equivalent emissions associated with different on-road vehicular traffic on the highway sections (Mukherjee et al. 2013). This is done using the EPA's current official model for estimating air pollution emissions from motor vehicles under different traffic scenarios, MOVES (Motor Vehicle Emission Simulator) (EPA 2010a). This tool replaces the previous EPA official estimator, MOBILE6. MOVES is used for estimating emissions from motor vehicles at the national, county, and project scale. For this study, MOVES is used to estimate CO<sub>2</sub> equivalent at the project scale. The project parameters are based on actual MDOT project information. The project scale allows for more detailed input parameters to be analyzed, which consequently creates a more accurate emission estimation of the particular roadway. The parameters used are specific sections of highway with unique attributes such as road type, length, speed, Average Daily Traffic (ADT), and meteorology. At the project level, all of these specific parameters are inputs into the MOVES database.

Two projects were evaluated using MOVES. The first project was US-41, which is a two lane major collector road located in Northern Michigan in Marquette County. This road type is classified in MOVES as a type 3 road, which is a rural unrestricted access roadway. The second project was I-69, which is an expressway located in southeast Lower Michigan in both Genesee and Lapeer County. This road type is classified as a type 2 road, which is a rural restricted access roadway. These projects were both actual MDOT road construction projects. The inputs for the project level analysis were very specific. They describe the unique project parameters. The inputs are fuel supply and fuel formulation, local meteorology, including temperature and relative humidity, vehicle/source type fraction for Vehicle Miles Travelled (VMT), vehicle population fraction, traffic speed, project length, road grade, ADT, and the driving schedule (traffic maintenance schedules during a maintenance scenario).

The fuel supply and formulation data were a default input generated from the MOVES database. This data include very specific information regarding the physical makeup and market share of gasoline and diesel fuel, explanation of which goes beyond the scope of the study that this chapter is based on.

The climate data include the temperature and relative humidity for a typical day in a month incremented by 1 h. Each of these 1 h meteorology snapshots is specific

to the county that is selected in the MOVES graphical user interface (GUI). MOVES also provides this detailed data within its database. Therefore the default data were used.

The vehicle type fraction data is the fraction of VMT that each vehicle type can be assigned. The user is required to assign fractions to each MOVES-specific vehicle type using the particular roadway. These fractions can be defined monthly, type of day or hourly. For this study an average fraction was assumed for each of the two road types. MOVES allows vehicle type fraction information to be imported from Highway Performance Monitoring System (HPMS). HPMS is a national level database maintained by FHWA detailing information about “the extent, condition, performance, use and operating characteristics of the nation’s highway” (FHWA). The information for HPMS vehicle class fraction was found at the Office of Transportation Data for the Georgia Department of Transportation, for vehicle classes 1, 2, and 3, for each specific road type (GDOT 2009). For the heavy truck classes 4 through 13, the default traffic fractions from the Mechanistic-Empirical Pavement Design Guide (ME-PDG) program were used. The choice of ME-PDG is based on its wide acceptance and general reliability as a pavement design tool. These fractions were combined using the assumed fraction that 15 % of the total traffic is heavy trucks. These fractions had to be reclassified in order to conform to the MOVES required source type. The HPMS vehicle classes were grouped into the MOVES source types. Some were matched directly, like motorcycles, while some MOVES source types contained multiple HPMS vehicle classes such as combination long haul trucks. The HPMS classes were fractioned and added up according to the MOVES source type they mapped on to. Table 3.1 outlines the vehicle type fraction data that was used from HPMS and input into MOVES to characterize the traffic in the simulation.

The variable fractions are uniformly distributed. For example,  $x_4$  indicates the fraction of traffic that belongs to HPMS class 4, which consists of vehicle source types 41, 42 and 43. As vehicle types 41 and 42 are not considered for rural scenarios, their representation in  $x_4$  is null. Hence, the fraction  $x_4$  is representative only of vehicle source type 43. Similarly, the vehicle source types 31 and 32 are represented equally in the fraction  $x_3$ , which represents HPMS vehicle type 3. Therefore, the representative variable for 31 and 32 is  $x_3/2$ . Intercity and transit busses were not factored into MOVES because they were assumed to not drive on rural roads or rural highways.

The vehicle age distribution is the fraction of vehicles on the road by how old they are for each of the MOVES source types. MOVES ranges from 0 to 30, new to 30 + years old respectively. This information was found at the EPA website as a default input ((EPA) 2010). The data were modified slightly to reflect the fraction of cars by age, which is a required input in MOVES, rather than the total number of cars by age.

The most crucial input into MOVES is the link input. This describes the project specifics, like road length, average speed, ADT, and percent grade. The length (in miles from POB to POE) of the projects were determined from project descriptions from MDOT, this is in miles from beginning to end. The average speed

was assumed to be the permanent speed limit set on the road. The ADT was found at the MDOT website and is specific to each section of road (MDOT 2009). This data were averaged if there were more than one ADT given on a single section of road. The ADT was broken down by the hour. For simplicity, the ADT was fractioned equally between all 24 h of the day. This becomes the average hourly traffic. The percent grade of the road for a particular project was calculated from a website that uses the elevation of two user-chosen points on a map (veloroutes.org 2010). The points used for these projects were the start and end of the particular project.

When determining the emissions from daily traffic during a construction or maintenance scenario, additional driving schedule information was used. The driving schedule reflects traffic management in a construction work zone, particularly the change in traffic speed as vehicles enter and exit a work zone. It was assumed that for the unrestricted road type a typical vehicle will come to a stop from 55 mph, and remain stopped for 10 min, (600 s—maximum allowable by MDOT), then speed up to the reduced speed through the construction zone (assumed to be 45 mph), and finally accelerate to a normal driving speed of 55 mph. A maintenance period driving schedule for a restricted road consists of all vehicles slowing down from 70 to 60 mph. For simplicity, the acceleration and deceleration of traffic was assumed constant. The second by second data were calculated using the following formulae for constant acceleration (based on time and distance respectively).

$$a = [v_f - v_i]/t \text{ \& } a = [v_f - v_i] [v_f - v_i]/[2 \times d]$$

where  $a$  = acceleration,  $v_f$  = final velocity,  $v_i$  = initial velocity,  $d$  = distance, and  $t$  = time. Each section where there is a change in driving pattern (due to the work zone) is considered to be a new “link” in the roadway. These had to be input as separate links in the link table as well. Each link had to be given a new average speed based on the acceleration, and a new length, which was calculated from the acceleration formula to solve for distance. Table 3.2 is an example of the driving schedule table and Table 3.3 of the link table.

MDOT’s project plans specify the distance before the work zone where a speed reduction sign is located. This distance  $D$ , was used to account for the deceleration of the vehicle as it approached the work zone (Santero et al. 2011). This distance varied with the speed limit of the road. The time values, when used, were estimated based on driving experience.

Once the data were estimated using MOVES it was put together into a spreadsheet to be analyzed and made useful. All the hours in a month were summed to form a typical days’ worth of CO<sub>2</sub> equivalent emission. Then each of these typical days in a month were multiplied by the number of days in the particular month and summed to estimate a typical year (typical Jan day\*31 + typical Feb day\*28.25 + ... + typical Dec day\*31). This total represents the total CO<sub>2</sub> emissions on a specific section of highway for one year. To calculate emissions for an average day, the total was divided by the number of days in a year, 365.25. This total annual emission can then be represented as a metric by fractioning the average

**Table 3.2** Driving Schedule Table

Link id	Second id	Speed	Grade
1	1	55.00	0
1	2	50.97	0
1	3	46.93	0
1	4	42.90	0
1	5	38.87	0
1	6	34.83	0
1	7	30.80	0
1	8	26.77	0
1	9	22.73	0
1	10	18.70	0
1	11	14.67	0
1	12	10.63	0
1	13	6.60	0
1	14	2.57	0
1	15	0.00	0
2	1	0.00	0
2	600	0.00	0
3	1	0.00	0
3	2	3.75	0
3	3	7.50	0
3	4	11.25	0
3	5	15.00	0
3	6	18.75	0
3	7	22.50	0
3	8	26.25	0
3	9	30.00	0
3	10	33.75	0
3	11	37.50	0
3	12	41.25	0
3	13	45.00	0
5	1	45.00	0
5	2	47.00	0
5	3	49.00	0
5	4	51.00	0
5	5	53.00	0
5	6	55.00	0

emissions per day by the length of the project and the ADT of the project. The units for this emission metric are metric tons of CO<sub>2</sub>e/day/mile/1,000 vehicles. This provides a functional unit for considering the emissions during the service life of pavements with equivalent functionality, as defined by traffic volume.

**Table 3.3** Link table

Link id	County id	Zone id	Road type id	Link length	Link volume	Link avg speed	Link description	Link avg grade (%)
1	26103	261030	3	0.10417	125	26.86	55–0	0
2	26103	261030	3	0.00000	125	0	Stopped	0
3	26103	261030	3	0.07500	125	22.5	0–45	0
4	26103	261030	3	2.77139	125	45	Drive through project	0
5	26103	261030	3	0.06944	125	50	45–55	0

Throughout the life cycle of the road, the total emissions were estimated using a 1 % growth in ADT each year (Santero et al. 2011). This growth factor for ADT directly correlates to the emission output and was backed up by a sample MOVES run at the national scale over a period of 20 years. The trend in the yearly data of this set was growing at slightly over 1.07 %. This result justified the assumption of 1 % growth in emissions per year.

### 3.6.4 Functional Units and Metrics

The functional unit ‘*emissions per lane mile*’ has been used widely in the literature. However, this unit has various limitations—most importantly, it does not scale in any uniform fashion as the number of lane miles increase. One reason is that the length of shoulder does not increase in the same way as the number of lane miles increase. In addition, there is an impact of statistical smoothing as the denominator increases. Therefore, for the sake of this study, it is not suitable as the *only* functional unit, as the proposed framework accounts for multiple pavement functionalities. The functionalities include:

1. Product performance (e.g. differences in emissions of alternative and/or recycled materials compared to virgin materials);
2. Process performance (e.g. savings in emissions through appropriate construction site layout, schedule and operation design), and
3. Services performance (e.g. increased emissions due to construction zone delays and emissions for different maintenance schedules and pavement life cycles).

In addition, it is important to note that while this framework is inspired by LCA approaches, its aim is not to compare products and processes—but to instead provide decision-support to strategically reduce GHG emissions for each of these functionalities. Hence, most of the units discussed in this section are intended to be decision metrics rather than pure functional units. Therefore, the choice of an



appropriate functional unit/metric depends on the decision being considered. Broadly, the following functional units were considered:

1. Product Component: Project level perspective
  - Average CO<sub>2</sub> equivalents per 100 m of cementitious and asphaltic materials (see explanation later);
  - Average overall CO<sub>2</sub> equivalents per MDOT material specifications as defined in Michigan DOT's material specifications denoted as Division 9, reported per lane mile;
  - Average overall CO<sub>2</sub> equivalents per construction category (e.g. Drainage, Earthwork) per lane mile;
  - Equipment manufacturing and upstream fuel production emissions per lane mile, and
  - Transportation emissions of raw materials to site per lane mile.
2. Process Component: All emissions expressed per working day of project—Construction activity/schedule level perspective
  - Composite materials production on site (e.g. batch plant emissions);
  - Secondary materials processing on site (e.g. RCA, RAP);
  - Emissions due to delays in construction schedule, and
  - Emissions related to construction operation design.
3. Service Component: Project/Network level
  - CO<sub>2</sub> equivalent emissions expressed in units of vehicle emissions per day per mile, where one unit of vehicle emissions per day per mile, is the daily emission (in mt) associated with a mile length of a highway section with Average Annual Daily Traffic (AADT) of 1,000. The emissions for a given highway section over a period can be derived by multiplying the metric, by the AADT and period being considered, and
  - Integrative life cycle emissions of a highway section per lane mile considering all the components and phases.

It is important to note that all the units discussed above are incomplete and must be taken as a whole. Strictly speaking, they *should not* be used to compare processes and materials. Rather, they should be used as metrics to establish benchmarks for representative project types and highway sections. In turn, these can be used as baselines to support decision-making and continuously increase efficiency.

Of the above metrics, the ones that were specifically investigated and developed were Average CO<sub>2</sub> equivalents per 100 m of cementitious and asphaltic materials (see explanation later), and the service component metrics. In both these cases, a calculated metric was derived as discussed next.

### 3.7 Average CO<sub>2</sub> Equivalents Per 100 m of Cementitious and Asphaltic Materials

This metric has been derived from a measure developed by ICF International Inc., as part of a recent study investigating GHG mitigation measures in Transportation Construction (Gallivan 2010). It expresses the material emissions per 100 m of cementitious or asphaltic materials. The definition of cementitious and asphaltic materials is as follows. Cementitious Material Emissions are defined as the emissions from the cementitious materials—cement, aggregate, fly ash, sand, steel, and curing compound—that go into a 15 ft. long by 12 ft. wide by 11 inch deep concrete panel that has 10 dowel bars spaced 12 inch. on center, and 6 tie bars spaced 30 inch. on center (As illustrated in Fig. 3.1). The concrete unit weight mix design and the weight of materials for such a panel are illustrated in Tables 3.4 and 3.5. The emissions from this panel were calculated to be 1.5417 m of CO<sub>2</sub> equivalents per panel or 13.88 m of CO<sub>2</sub> per 100 m of cementitious materials. This compares with GreenDOT’s metric of 15.484 m of CO<sub>2</sub> per 100 m of cementitious materials. Asphaltic Material Emissions are defined as the emissions from asphaltic materials—binder, aggregate, sand, RAP, and bond coat—that go into a 15 ft. long by 12 ft. wide by 12 inch. deep asphalt panel (as illustrated in Fig. 3.2). The HMA unit weight mix design and the weight of materials for such a panel is illustrated in Tables 3.6 and 3.7. The emissions from this panel were calculated to be 0.1532 m of CO<sub>2</sub> equivalents per panel or 1.294 m of CO<sub>2</sub> per 100 m of asphaltic materials. This does not compare with GreenDOT’s metric of 7.325 m of CO<sub>2</sub> per 100 m of asphaltic materials.

It is important to note that the terms ‘cementitious’ and ‘asphaltic’ are being used on purpose and are not to be confused with ‘concrete’ and ‘asphalt’. The terms

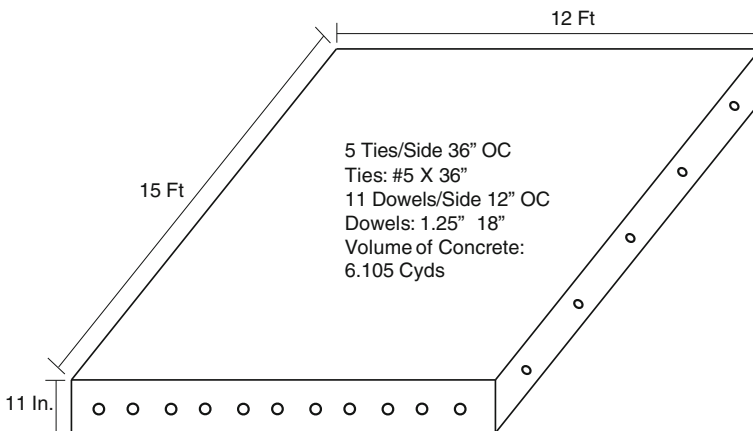

Fig. 3.1 Concrete panel design

**Table 3.4** Concrete unit weight mix design

Concrete unit weight mix design/cyd of concrete	*Unit/cyd of concrete	% of mix by weight	Emission factor	Unit
Cement *(ton)	0.240	12.037	8.42E-01	mt/ton
Aggregate *(ton)	0.951	47.758	6.16E-03	mt/ton
Sand (cyd)	0.376	30.554	1.08E-04	mt/cyd
Fly Ash *(ton)	0.042	2.124	1.78E-02	mt/ton
Water *(ton)	0.150	7.527	NA	
(0.45 W/C Ratio) (Unit Weight: 1.9914 tons Concrete/cyd Concrete)				
Overall Emissions (mt CO <sub>2</sub> )/cyd of Concrete	2.08E-01			

**Table 3.5** HMA unit weight mix design

HMA unit weight mix design/ton of HMA	*Unit/Ton of HMA	% of mix by weight	Emission factor	Unit
Binder *(ton)	0.053	5.32	1.57E-01	mt/ton
Aggregate *(ton)	0.331	33.14	6.16E-03	mt/ton
Sand (cyd)	0.292	47.34	1.08E-04	mt/cyd
RAP *(ton)	0.142	14.20	4.92E-03	mt/ton
Overall Emissions (mt CO <sub>2</sub> )/Ton of HMA	1.11E-02			

represent a conglomerate of materials based on the definition of the standard pavement panels. Therefore, they are representative of emissions associated with 100 m of such a panel. The pavement material bulk is then expressed as a function of such panels. For example a project with 500 m of asphaltic materials could be compared to five 100 m of a typical asphaltic panel as described. It is important to note that most major projects (and this is evident in a later section) can be expressed as a combination of asphaltic and cementitious panels. The choice of this unit is to develop a standard reference that all project materials can be expressed as—*thus providing the ability to compare the emissions of different projects, rather than compare the emissions of different pavement types.*

The Society of Environmental Toxicology and Chemistry (SETAC) guidelines for conducting a LCA, states that if the material comprises less than 1 % of the total product, it can be neglected in the LCA (SETAC 1994). Therefore, concrete admixtures such as air entrainer and set modifier along with HMA additives have been omitted from this calculation.

These emissions are estimated from the panel designs and can be compared to the metrics provided in a recent National Cooperative Highway Research Program

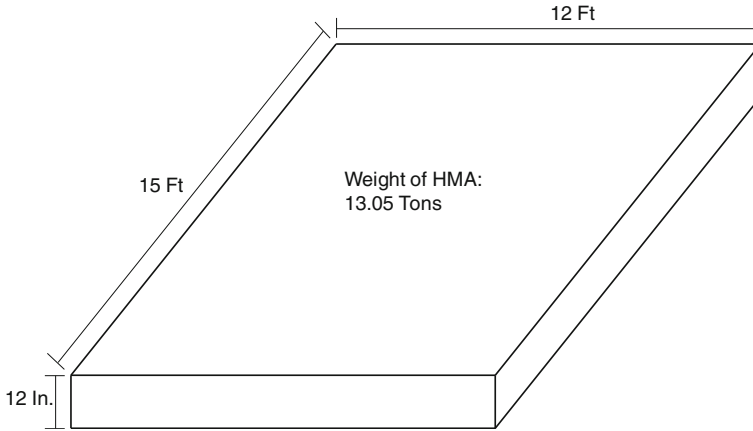

**Fig. 3.2** HMA panel design

**Table 3.6** Concrete panel mix design

Component	Weight/ volume	Unit	Emission factor	Unit
Cement	1.722	Tons	8.42E-01	mt/ton
Course agg	5.806	Tons	6.16E-03	mt/ton
Fine agg	2.293	Cyds	1.08E-04	mt/cyd
Steel	0.085	Tons	5.20E-01	mt/ton
Curing Compound	0.720	Gallons (\$18.30/Gal)	0.96	mt/\$1000
Equivalent to 6.105 cyds and Approximately 12.242 tons (11.105 mt) *Sand = 120 pcf				
Overall Emissions (mt CO <sub>2</sub> )/Panel			1.5417	
Overall Emissions (mt CO <sub>2</sub> )/100 mt			13.880	

(NCHRP—GreenDOT) study (Gallivan 2010). The metric for the cementitious materials is comparable. However, the discrepancies in the metric for asphaltic materials are due to choices of emission metrics used as described below:

1. Aggregate Factor:
  - Used in this research: 0.00616 m CO<sub>2</sub>/m
  - Used in NCHRP Study: 0.012 m CO<sub>2</sub>/m
2. Binder factor:
  - Used in this research: 0.157 m CO<sub>2</sub>/m
  - Used in NCHRP Study: 1.237 m CO<sub>2</sub>/m

These emissions factors were used because there is precedence of their use in other credible LCA studies (Athena 2006; Stripple 2001).

**Table 3.7** HMA panel mix design

Component	Weight/ volume	Unit	Emission factor	Unit
Binder	0.694	Tons	1.57E-01	mt/ton
Aggregate	4.325	Tons	6.16E-03	mt/ton
Sand	3.814	Cyds	1.08E-04	mt/cyd
RAP	1.853	Tons	4.92E-03	mt/ton
Bond Coat	0.800	Gallons (\$6.90/Gal)	1.45	mt/\$1000
Equivalent to 13.05 tons (11.838 m) HMA *Sand = 120 pcf				
Overall emissions (mt CO <sub>2</sub> )/Panel			0.1532	
Overall emissions (mt CO <sub>2</sub> )/100 m			1.294	

### ***3.7.1 CO<sub>2</sub> Equivalent Emissions of on-Road Vehicular Traffic***

CO<sub>2</sub> emission equivalents were estimated using a metric derived in the vehicle use scenarios modeled in MOVES. The metric used was m of CO<sub>2</sub> emissions/day/mile/1,000 vehicles—its calculation has been explained in a previous section.

### ***3.7.2 Life Cycle CO<sub>2</sub> Equivalent Emissions***

Life cycle GHG emissions can be estimated by summing all product, process, and service components described earlier in this chapter. The life cycle components for an analysis period of  $N$  can be summarized as follows:

1. Construction emissions (includes product, and process emissions plus the emissions due to traffic delays);
2. Maintenance emissions (includes product, and process emissions plus the emissions due to traffic delays). Total number of maintenance emissions is equal to the number of interventions over the analysis period. The number and timing of the maintenance operations can be estimated from the highway historical performance, and
3. Total service phase emissions (includes the emissions resulting from on-road vehicular traffic) as estimated using the MOVES simulator.

Sum of each of the above components provides the gross emissions,  $E$  for the pavement section over the entire time horizon of  $N$  years. The relevant metric is the

equivalent uniform annualized emissions expressed the same way as the equivalent uniform annualized cost is in a lifecycle cost analysis.

### 3.8 Inventory Assessment

This section outlines the general results that were observed from an assessment of the project emissions data. This section investigates the metrics described in the project based LCA framework under the following categories:

- Product Emissions: Primarily focusing on materials used in construction projects;
- Process Emissions: Primarily focusing on construction operations common to most highway projects, and
- Service Emissions: Primarily focusing on emissions during the service life of the pavement dependent on maintenance scheduling and vehicular traffic emissions.

#### 3.8.1 Product Emissions

The product emissions can be classified into the following categories:

- The cementitious material tonnage was calculated by summing all the material used for work in MDOT Sects. 901, 903, 905, 914, 915 and total tonnage of concrete in any other section (this is usually extremely small). The emissions observed for this material cluster was divided by the total tonnage for the cluster and multiplied by 100 to produce the observed emissions per 100 m of cementitious material, and compared with the theoretical value calculated in Sect. 4.5.1,  $u_{conc} = 13.88$  m per 100 m;
- The asphaltic material tonnage was calculated by summing all the material used for work in MDOT Sect. 904 and all volumes of HMA. The emissions observed for this material cluster was divided by the total tonnage for the cluster and multiplied by 100 to produce the observed emissions per 100 m of asphaltic material, and compared with the theoretical value calculated in Sect. 4.5.1,  $u_{asp} = 1.294$  m per 100 m;
- The earthwork emissions were calculated by summing emissions from the material used for work in MDOT Sects. 902, 910, 916 and 917;
- The drainage emissions were calculated by summing emissions from the material used for work in MDOT Sects. 909 and 913, and
- Materials in all other sections in Division 9 were classified as miscellaneous.

The purpose of breaking up total project emissions into these categories is to create a metric that can be used to benchmark material emissions, instead of comparing one material/pavement type to another. Hence, major concrete pavement

reconstruction projects had HMA use and vice versa. For all the observed projects the values were calculated as indicated in Table 3.8:

The values presented in Table 3.8 show that for construction and reconstruction projects (R1 and R2) all the different material categories are well represented. For the maintenance projects, (M1 and M2) the type of project influenced the distribution of emissions in each of the categories. *It is important to reiterate that the emissions for cementitious and asphaltic materials categories are representative of a particular collection of materials and should not be confused as a comparison between with concrete and asphalt pavements.* The metric that showed the most significant trend was a measure of the emissions per 100 m of cementitious materials and asphaltic materials as defined in Sect. 4.5.1. Specifically, an important trend was noticed, in the emissions per 100 m of cementitious material and asphaltic materials, across all the R1 and R2 projects, leading to the following notion:

The factors  $u'_{\text{conc}}$  and  $u'_{\text{asp}}$ , calculated from the observed data represents a consistent metric across all projects, comparable to the theoretical estimates of  $u_{\text{conc}}$  and  $u_{\text{asp}}$ . Where  $E_{\text{conc}}$  and  $E_{\text{asp}}$  are the emissions associated with concrete and asphalt materials (as calculated from observed site data), and  $M_{\text{conc}}$  and  $M_{\text{asp}}$  are the weights in meter of all the cementitious and asphaltic materials (as observed from site data), and

$$E_{\text{conc}} \times (1/ M_{\text{conc}}) = u'_{\text{conc}}; E_{\text{asp}} \times (1/ M_{\text{asp}}) = u'_{\text{asp}}$$

This notion could gain credibility if, the product of  $E_{\text{conc}}$  and  $(1/M_{\text{conc}})$  is constant across all observed projects. The constant then would be equal to  $u'_{\text{conc}}$ . Similarly, across all observed projects, the product of  $E_{\text{asp}}$  and  $(1/M_{\text{asp}})$  would be a constant and equal to  $u'_{\text{asp}}$ .

Figures 3.3, 3.4, 3.5 and 3.6 illustrate the plots of  $1/M_x$  versus  $E_x$  ( $x =$  cementitious or asphaltic materials), for the different project classifications (R1 and R2, and M1 and M2). As can be seen from the regression models illustrated in Table 3.9, the observed metric validates the notion described above. In addition, it is similar to the calculated metric thus further adding credibility to the observation. This is a step towards establishing a metric to benchmark emissions for future projects.

The exception is the case representing M1 and M2 projects involving cementitious materials. This may be possibly explained by the fact that the observed M1 and M2 projects were primarily asphalt pavements and had very limited use of cementitious materials. In general the reliable metrics are the observed and calculated values for cementitious and asphaltic materials for R1 and R2 project types.

It is important to reiterate that the purpose of this metric is not to compare asphalt and concrete materials. The definitions of asphaltic and cementitious materials are based on a clustering of specific material sections in Michigan DOT's material specifications, identified as Division 9 that contribute to asphalt and concrete pavement construction respectively. The significance of the metric is that it can be used to estimate emissions for new projects based on a material estimate. It is also very important to note that this metric represents only emissions of materials in

**Table 3.8** Total emissions in meter of CO<sub>2</sub> equivalents

Type	Job	Cementitious	Asphaltic	Earthwork	Drainage	Misc	Total	Lane miles
M1	Concrete patch repairs and HMA resurfacing	303	12	0	0	32	346	9
M1	Full depth concrete pavt joint and crack repairs	186	0	0	0	73	259	3
M1	HMA cold milling and resurfacing	0	141	8	0	104	253	14
M1	HMA cold milling and overlay	37	208	66	0	39	350	17
M2	Transverse and long. joint cutting and resealing (conc.)	72	0	0	0	53	125	35
M2	Microsurface	38	2593	70	93	174	2968	51
M2	Overband crack filling and micro surface	26	227	8	0	35	295	9
M2	Overband crack seal and microsurface	12	296	9	0	50	367	28
R1	HMA reconstruct	98	1164	215	404	588	2468	13
R1	Concrete reconstruct	32813	300	2066	865	1544	37588	41
R1	HMA reconstruct and roadway realignment	36.21	251.71	284	374	276	1222	6
R1	Road reconstruction HMA and concrete	572	171	122	1139	60	2064	4
R2	Unbonded concrete overlay	18635	685	852	1089	1936	23196	28
R2	Asphalt crack relief layer; reconstruction; crush and shape	332	309	143	198	47	1029	6



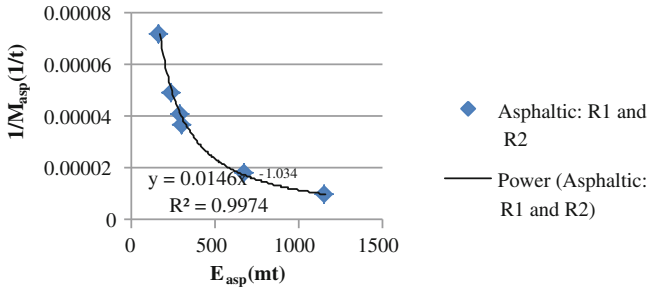

Fig. 3.3  $1/M_{asp}$  (y-axis) versus  $E_{asp}$  (x-axis) for R1 and R2 projects—Asphaltic

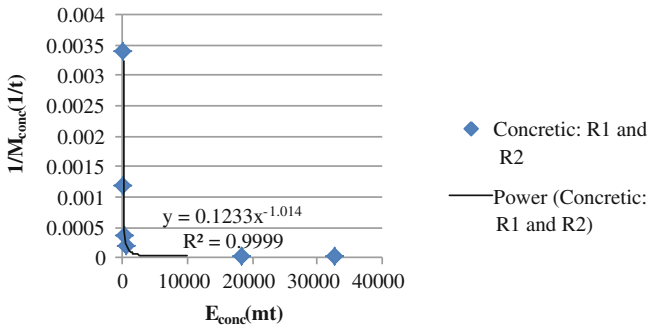

Fig. 3.4  $1/M_{conc}$  (y-axis) versus  $E_{conc}$  (x-axis) for R1 and R2 projects—Cementitious

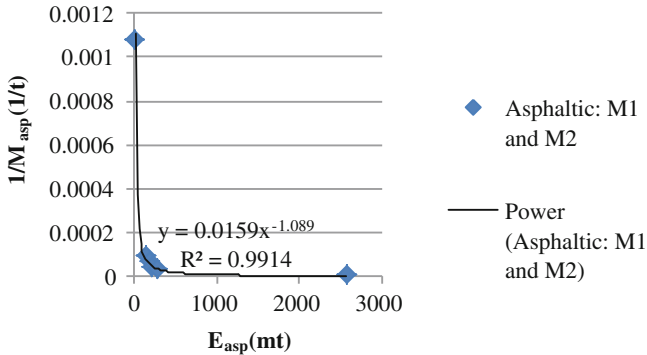
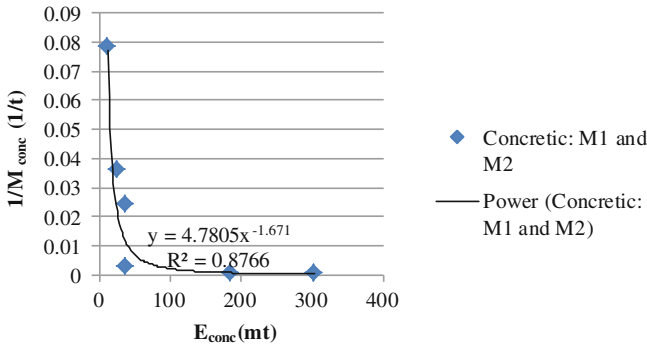

Fig. 3.5  $1/M_{asp}$  (y-axis) versus  $E_{asp}$  (x-axis) for M1 and M2 projects—Asphaltic

the pavement (product component)—and therefore is a reflection of only part of the pavement life cycle emissions. It strictly accounts for the cradle-to-gate emissions. The performance of a project and/or pavement accounts for emissions from the process and service components as well.



**Fig. 3.6**  $1/M_{conc}$  ( $y$ -axis) versus  $E_{conc}$  ( $x$ -axis) for M1 and M2 projects—Cementitious

**Table 3.9** Emission regression models, (metrics expressed in meter of CO<sub>2</sub> emissions/100 m of material weight)

Project type	Material type	Regression equation	R <sup>2</sup>	Observed metrics	Calculated metrics
R1 and R2	Cementitious material	$E_{conc}^{1.008} \times (1/M_{conc}) = 0.1233$	0.99	$u'_{conc} = 12.33$	$u_{conc} = 13.88$
	Asphaltic material	$E_{asp}^{1.034} \times (1/M_{asp}) = 0.0146$	0.99	$u'_{asp} = 1.46$	$u_{asp} = 1.296$
M1 and M2	Cementitious material	$E_{conc}^{1.59} \times (1/M_{conc}) = 4.7805$	0.87	$u'_{conc} = 478.05$	$u_{conc} = 13.88$
	Asphaltic material	$E_{asp}^{1.089} \times (1/M_{asp}) = 0.0159$	0.99	$u'_{asp} = 1.59$	$u_{asp} = 1.296$

### 3.8.2 Process Emissions

This section investigates the emission from construction operations and schedule delays on construction sites. A particular project was studied in depth to illustrate how inefficiencies in project planning and scheduling can increase project emissions. This analysis builds on the method to collect and analyze construction project emissions data, and calculates the associated GHG emissions by comparing the as-planned and as-built schedules. The purpose of this analysis is to identify the impact of construction delays on project emissions. The delays often result from unexpected circumstances that unfold during the project construction, that were not or could not have been anticipated during the project planning process. It is expected that reduction in such delays and rework can reduce additional resource usage—as compared to the as-planned resource usage—thus increasing total project emissions. The following analysis investigates this notion by comparing the emissions associated with the as-planned resource loaded schedule and the as-built resource loaded schedule.

Data collected from FieldManager™ were used to develop the as-built observed schedule. The as-planned schedule was developed using the progress schedule (MDOT Form 1130) that is submitted by the contractors to MDOT project delivery engineers, before the construction start date. Also used to develop the as-planned schedule was the project proposal's engineering estimate (bid tab). The progress schedule outlines construction activities along with proposed starting and end dates for each activity. Driving activities, defining the actual construction of the roadway were identified and used. Henceforth they are referred to as primary activities. These activities were assigned a division of work and section number as defined in MDOT's Standard Specifications for Construction (MDOT 2003). In addition, a controlling pay item was identified to represent each activity. These primary activities and controlling items were used to characterize the parameters in the schedule analysis.

It was necessary to identify primary activities and controlling items when assessing differences in schedule performance because the scope of this analysis is to investigate GHG emissions associated with the highway construction process in particular. The activities were chosen so that they are representative of typical highway construction projects. Therefore, mainline paving activities are considered as primary activities as they are common to all projects and variation in them due to site conditions can be compared across projects. However, traffic control activities were excluded, as there is limited data to support their inclusion.

The information from FieldManager™ was organized by tabulating the resources associated with each controlling item installed for each of the primary activities for each day of the project. The controlling item identification number (Pay Item #) identified in the as-planned schedule was also used generate as-built information from FieldManager™. Information representing daily activity and productivity information was analyzed. The controlling items were allocated to working dates, an identification number, quantities installed and equipment used. The importance of this data organization and classification is that it can be utilized to generate as-built schedules automatically from FieldManager™ data.

The data collected through FieldManager™ and outlined in the progress schedule and engineer's estimate were used to develop material, and fuel inventories for the as-planned and as-built schedules, which in turn can be used to calculate emissions from materials and equipment used throughout the schedules. Using the described methodologies the emissions were estimated comparing as built and as planned material consumption and equipment usage.

For a concrete reconstruction project that was studied, a comparison of the as-planned and as-built schedules shows a significant increase in equipment use on site, resulting in 7.8 m of extra CO<sub>2</sub> emissions. The impact of the extra materials used, as measured from their manufacturing phase, was approximately 807 m of CO<sub>2</sub> emissions (Figs. 3.7 and 3.8). The emissions due to extra equipment use on site (7.8 m of CO<sub>2</sub> emissions), is equivalent to the emissions produced in generating electricity to power an entire household for 1 year, or the emissions from 325 propane cylinders used for home barbeques (EPA 2010). The emissions due to extra materials installed due to rework, 807 m of CO<sub>2</sub> emissions, is equivalent to

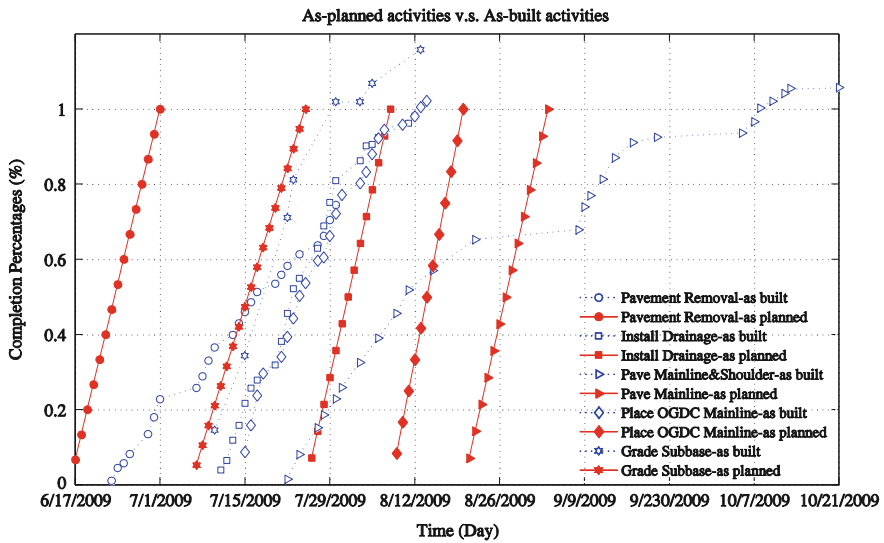

Fig. 3.7 As planned (red) versus As built (blue) schedule for a concrete reconstruction project

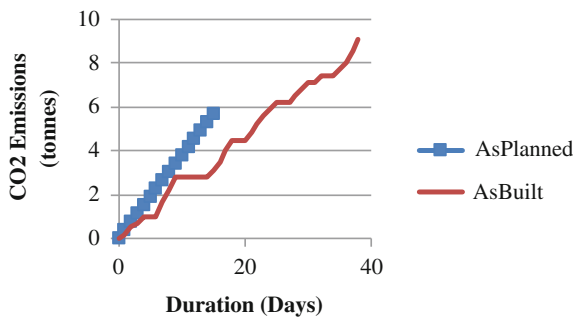

Fig. 3.8 Difference in As-built emissions versus as-planned emissions for a delayed pavement removal activity

providing electricity to 100 homes for an entire year or the emissions from 33,000 propane cylinders used for home barbeques (EPA 2010).

The result of this investigation shows that schedule delays and rework resulting from unexpected change orders during the construction process can lead to more than expected emissions on construction sites. Therefore, appropriate management of construction schedules and optimal use of materials and equipment on site during construction can significantly help in lowering emissions during highway construction. When considered for multiple construction projects across the nation, a focus on reducing emissions through better management of construction projects can result in significant savings. Management best practices developed in areas of

lean construction and lessons learned from construction operation simulations and planning can be transferred and applied very successfully to achieve these goals. This analysis presents a first step towards more detailed future research.

### ***3.8.3 Service Emissions***

Improved life cycle performance of highway sections plays a critical role in reducing GHG emissions. Long-life pavements that require little or no major rehabilitation throughout its life promises to lower the overall life cycle GHG emissions. With this in mind, designing long-term pavements considering durability and longevity will change the way highway sections are constructed. Long-life pavements can lead to lower overall life cycle GHG emissions. One study showed that 40 year designs compared to 20 year designs results in shorter return on environmental investment (Santero et al. 2011). However, long-term pavement performance studies are often limited due to limited regional availability of pavement construction performance data. Assessment of performance is critical to assess the long-term effectiveness of alternative materials (industrial by-products) and construction processes that promise to reduce the energy and greenhouse gas emissions (Muga et al. 2009). A FHWA Long Term Pavement Performance (LTPP) study identified some early trends that indicate the dependence of long-term pavement performance on design and site conditions (FHWA 1999). Ultimately, longer lasting pavements with reduced levels of maintenance can and will reduce life cycle GHG emissions. In this section, intervals of maintenance operation were investigated based on pavement condition to define a life cycle of flexible pavements in two regions of Michigan.

To define the overall pavement LCA, a life cycle period must be characterized outlining the various preventative maintenance strategies that will be implemented throughout the life of the highway section. Rehabilitation options are highlighted in MDOT's CPM manual (MDOT 2005), however, the time at which these options occur is not explicitly stated. Therefore, this research suggests deriving maintenance schedules based on historical performance of the pavement sections. This involves investigating historical pavement condition (Distress Index (DI)) data to determine when rehabilitation strategies are being carried out. The DI is a parameter used by MDOT to assess a pavement section's condition. It is a measure of the cracking distresses influencing the pavement's condition. A limited sub-set of data was used to investigate the performance of flexible pavements. For this analysis, regional variability was investigated. Distress index values were assessed over a 15 year period in two regions of Michigan and then compared to illustrate regional variability. The results of this analysis are outlined in Table 3.10. The third maintenance cycle was assumed to approach a DI of 35 before intervention.

From this limited performance/maintenance history analysis, the pavements in Region 2 reach a higher DI before maintenance operations are executed. In addition, the age at which the intervention occurs varies. The maintenance cycles occur

**Table 3.10** Regional performance and maintenance

Region 1			
<i>Maintenance operations</i>			
	Cycle 1	Cycle 2	Cycle 3
Age (years)	6.04	10.13	15.3
<i>Distress index (before/after)</i>			
Value	10.01/2.55	11.4/2.2	35/0
Region 2			
<i>Maintenance operations</i>			
	Cycle 1	Cycle 2	Cycle 3
Age (years)	7.44	12.75	15
<i>Distress index (before/after)</i>			
Value	27.3/11.4	24.7/17.5	35/0

in Region 2, on average, 1.44 years later than in Region 1. This could be a result of climate conditions in each region, local preferences, or other indicators such as IRI or rutting depth influencing when operations may occur.

This analysis can prove to be very beneficial in developing regional maintenance schedules that can be used as a guide to assess the environmental impacts of the maintenance phase of the LCA. Additionally, analysis like this can provide the essential timelines needed to define life cycle periods used in LCA. Performance based approaches like these promises to further the investigation of context sensitivity regarding the environmental impact of highway construction and maintenance operations.

### 3.9 Project Life Cycle Emission Estimation

A pavement's life cycle emissions are illustrated using the PE-2 estimator tool along with data from the observed MDOT projects. Figure 3.9 outlines a *conceptual plot* of the cumulative emissions associated with typical roadway's life cycle. It illustrates the sub-components of the service life of a pavement, namely initial construction, followed by vehicle use phases punctuated by maintenance operations and concluded by a final reconstruction. It is important to recognize that the life cycle illustrated here as well as the maintenance schedule is purely to illustrate the underlying method used. Indeed the PE-2 estimation tool allows users to test the life cycle emissions for life cycles and treatments of their own choice. The associated emission calculation components can be broken down as follows:

- Emissions from construction operations during reconstruction and successive maintenance and rehabilitation operations:
  - Emissions from the manufacturing and processing of virgin and recycled materials;

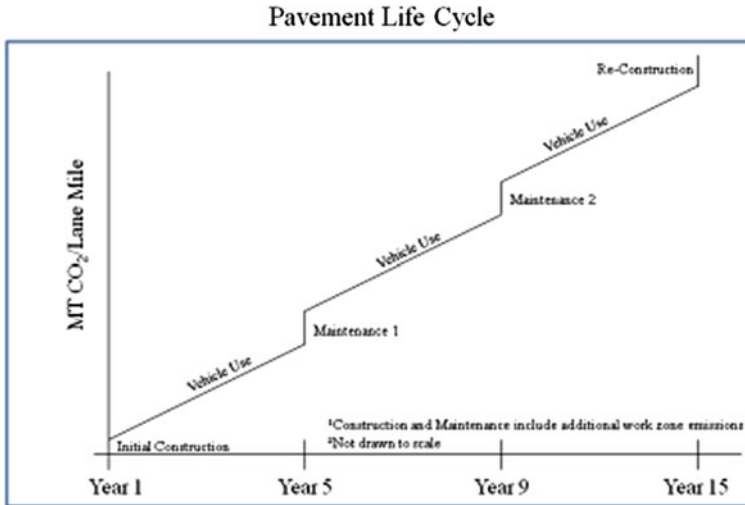

**Fig. 3.9** Conceptual illustration of pavement life cycle (MDOT 2011)

- Emissions from on-site construction equipment;
- Emissions from hauling equipment hauling materials to and from the project site;
- Upstream impacts for the manufacturing of the fuel combusted in the construction and hauling equipment, and
- Upstream impacts from the manufacturing of equipment being used on site.
- Work Zone Emissions during construction and maintenance operations:
  - Emissions associated with traffic delay throughout work zone durations.
- Use Phase Emissions:
  - Emissions associated with vehicle use of the roadway.

To illustrate the information outlined in Figure, the following example was modeled using the PE2 Life Cycle Tool and the following results were obtained:

General Project Information:

- Roadway Speed = 70 mph;
- Average Daily Traffic = 8,800 vehicles/day;
- Project Length = 10 miles, and
- Number of lanes = 4 (Results in 40 lane miles).

First intervention strategy:

- Emissions from US-31 HMA Reconstruct (PN50757) were used to account for year 1 initial construction and work zone emissions, and
- The duration of the project was determined to be 197 days.

Second intervention strategy:

- Emissions from US-31 Over band Crack seal and Micro surface (PN106529) were used to represent the first maintenance, and
- Defined at year 5, project duration determined to be 22 days.

Third intervention strategy:

- Emissions from M-20 HMA Cold milling and Overlay (PN105611) were used to represent the second maintenance, and
- Defined at year 9, project duration determined to be 95 days.

Final intervention strategy:

- Emissions from US-41 HMA Reconstruct and Realignment (PN80145) were used to represent the end-of-life, and
- Defined at year 15, project duration determined to be 283 days.

Results from the life cycle illustration are outlined in Table 3.11 and Fig. 3.10. Emissions associated with construction, maintenance and work zones are diminutive compared to emissions associated with vehicle use. Overall, annualized emissions per lane mile are approximately 511.27 m CO<sub>2</sub> Equivalent/year. In general, emissions from the use phase can represent 85–95 % of the pavement life cycle.

**Table 3.11** Life cycle emissions (MDOT 2011)

Year	Emissions/Year (Use)	Construction	Work zone	Total	Total Cum
1	418.2	365.37	8.31	791.88	791.88
2	422.39	–	–	422.39	1214.27
3	426.61	–	–	426.61	1640.88
4	430.88	–	–	430.88	2071.76
5	435.18	31.67	0.93	467.78	2539.54
6	439.54	–	–	439.54	2979.08
7	443.93	–	–	443.93	3423.01
8	448.37	–	–	448.37	3871.38
9	452.85	53.45	4.01	510.31	4381.69
10	457.38	–	–	457.38	4839.07
11	461.96	–	–	461.96	5301.03
12	466.58	–	–	466.58	5767.61
13	471.24	–	–	471.24	6238.85
14	475.95	–	–	475.95	6714.8
15	480.71	462.89	10.67	954.27	7669.07

Emissions are reported m CO<sub>2</sub> Eq/Lane mile



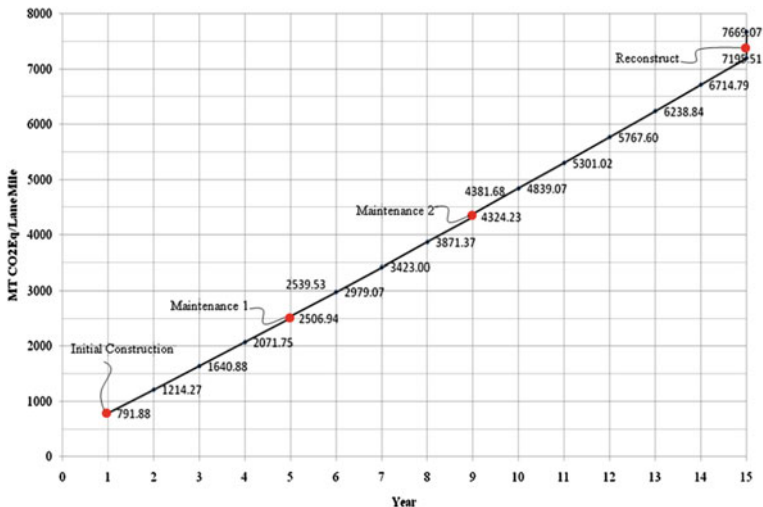

Fig. 3.10 Life cycle emissions (MDOT 2011)

### 3.10 Project Emissions Estimator (PE-2)

PE-2 is an interactive web-based service that was developed primarily using PHP: Hypertext Preprocessor (PHP)—a general purpose scripting language that is interpreted by a web server and used to dynamically generate web pages. PE-2 also uses Ajax technology—a combination of Javascript, CSS and HTML that create interactive web pages—to support a user-friendly interface primarily designed for contractors and agency decision-makers. The PE-2 tool can be accessed at [http://www.construction.mtu.edu:8000/cass\\_reports/webpage/](http://www.construction.mtu.edu:8000/cass_reports/webpage/). The goal of the PE-2 tool is two-fold:

1. Inventory Reporting: The PHP code queries the data server and calculates the GHG emissions using the methodology described earlier in this chapter. Hence, the user can choose a project, the PE-2 tool queries all relevant product and process data that was collected and dynamically creates a report for the particular project. The functional metrics are reported for each project as well.
2. Benchmarking & Estimating: The PE-2 web service provides an interactive web interface for decision-makers and contractors to aid them in benchmarking their projects. It uses the same methods used in calculating the emissions for the projects studied, as explained earlier in this chapter. However, it allows the user to provide the input through an easy to use interface. The input consists of materials and respective quantities, and the type, number and hours of estimated equipment usage (product and process). To make the interface easy to use, the user can choose the materials and equipment from a predefined list. In addition,

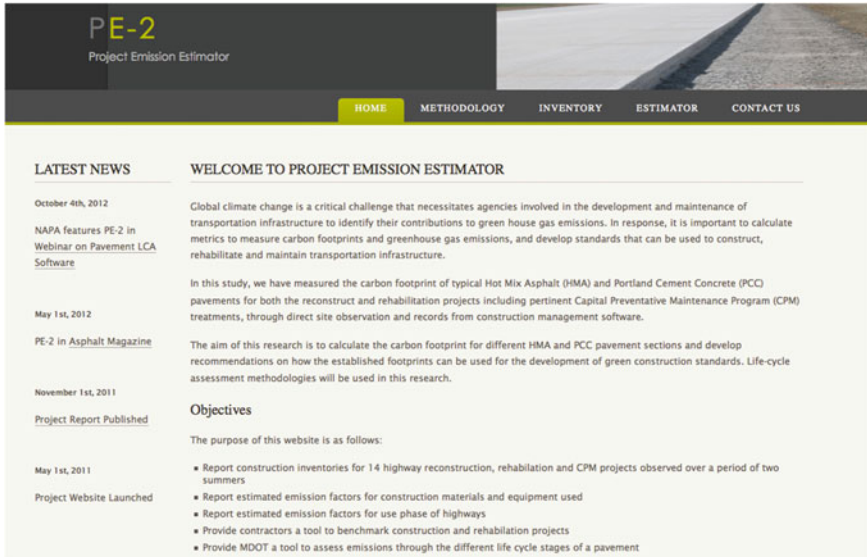

Fig. 3.11 PE-2 homepage

the material list in the drop-down menu is classified by MDOT pay-item specifications to allow for easy navigation. The estimator tool also allows users to benchmark equivalent annualized emissions for a project by providing traffic characteristics and an expected maintenance schedule. It uses benchmark values for emissions of construction, reconstruction and maintenance operations based on the 14 surveyed projects and the estimated emission metrics for the project section given the simulated trends from the MOVES simulator.

The PE-2 interface has four main tabs with the following functionalities:

1. Home: Introduction to the project and the purpose of the tool (Fig. 3.11);
2. Methodology: Introduction to the underlying methodology;
3. Inventory: This is the inventory reporting interface. It provides a summary of the product and process emissions calculated. For each project a report is generated (Fig. 3.12), and
4. Estimator: This is the estimator interface and has three components to it:
  - The materials estimator: Fig. 3.13 illustrates the interface that allows users to add materials to a list by choosing the material from a list of items classified by pay-item divisions specified by MDOT. As the list builds, the summation button at the bottom of the page sums up the total emissions and the page can be printed off as a report;
  - The equipment estimator: Fig. 3.14 illustrates the interface that allows users to add number of equipment and number of hours of estimated usage, to a

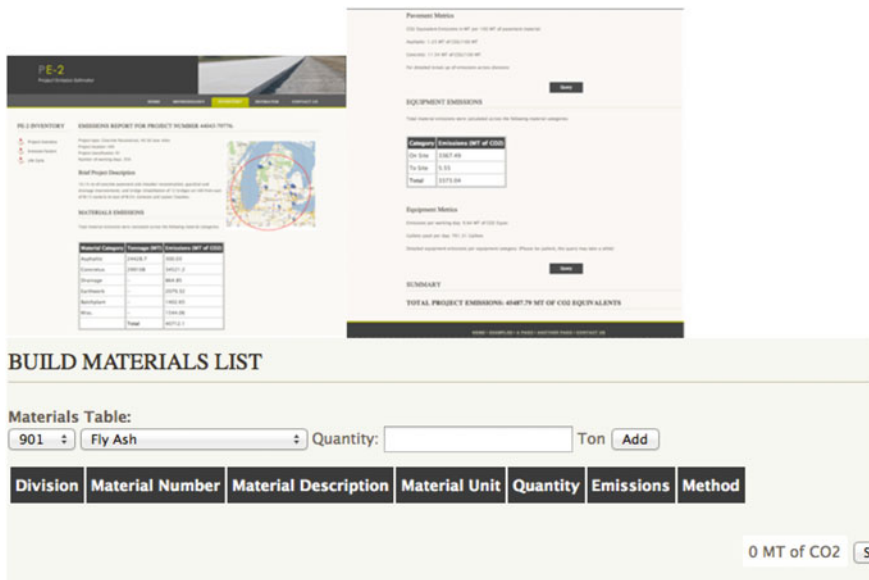

Fig. 3.12 Project inventory report

list by choosing the equipment from a list of classified by the activities that typically the items are associated with. As the list builds, the summation button at the bottom of the page sums up the total emissions and the page can be printed off as a report, and

- The life cycle estimator: Fig. 3.15 illustrates the interface that allows users to input project traffic characteristics and progressively build a construction and maintenance schedule to estimate the expected life cycle emissions. An example has been illustrated later in the chapter.

### 3.11 Discussion

The recommended application of the PE-2 tool is to monitor GHG emissions from construction projects, and to benchmark emissions for future projects. The PE-2 tool can be used at the project and the network levels.

At the project level, it can be used on all future projects to estimate and benchmark emissions. The first step would be to use the bill of materials and estimated material use to benchmark expected project emissions before the project starts. At the end of the project, PE-2 can be used to generate an emissions report using the actual data collected (data can be collected using FieldManager™ or

### BUILD EQUIPMENT LIST

The PE-2 Equipment Emission Estimator allows the user to generate emission reports based on the amount of equipment being used on site. Emission metrics are derived from fuel consumption. On-Site equipment is classified into 33 generalized equipment categories. The generated reports outline emissions and fuel used per working day of the contract per equipment category.

30 - Pressure Washers  Other  Number Used:  Hours:

Division	Fuel Rate	Equipment Description	Number Used	Hours	Emissions	Gallons Used
0 MT						

---

### GENERAL INFORMATION

Generalized Roadway Speed:  55mph  70mph

Average Daily Traffic (ADT):

Project Length (in miles):

Number of Lanes:

### BUILD LIFE CYCLE

M1  HMA Cold Milling and Overlay  Intervention Year:

Project Duration Days:

Year	Job Type	Type	Emissions per Lanemile	Project Duration Days
<input type="button" value="Get"/>				

Fig. 3.13 Material impact estimator

### BUILD EQUIPMENT LIST

The PE-2 Equipment Emission Estimator allows the user to generate emission reports based on the amount and durations of equipment being used on site. Emission metrics are derived from fuel consumption. On-Site equipment is classified into 33 generalized equipment categories. The generated reports outline emissions and fuel used per working day of the contract per equipment category.

30 - Pressure Washers  Other  Number Used:  Hours:

Division	Fuel Rate	Equipment Description	Number Used	Hours	Emissions	Gallons Used
0 MT of CO2 <input type="button" value="Sum Emissions"/>						

Fig. 3.14 Equipment impact estimator

**Fig. 3.15** Life cycle impact estimator

equivalent reporting software). Agencies should encourage contractors (through direct economic or equivalent incentive) to reduce the actual project emissions when compared to the benchmark for the project.

In addition, contractor's efforts at reducing GHG emissions during the project construction process (as measured by the difference between the as estimated and actual emissions) can be recognized through an incentive program. Contractors can beat their benchmarks through more efficient project site design and schedule planning or using alternative materials during the construction process.

When considering emission reduction strategies, it is crucial that agencies recognize that emission reduction is part of a broader goal of building more sustainable pavements. Therefore, all measures must consider the long-term socioeconomic outcomes as well. For example, an easy way of reducing equipment emissions would be to mandate the use of new and more expensive equipment that have reduced emission footprints. However, this would bias the playing field in favor of larger national contractors, crowding out smaller regional contractors who have fewer financial resources to purchase new equipment. Such socioeconomic impacts should be carefully considered. Reduction strategies should emphasize incentive based individual adoption based on win-win premises for all stakeholders, rather than top-down enforced standards that may disproportionately disadvantage certain stakeholders.

### 3.12 Conclusions

The highway construction industry is cautiously responding to challenges of emission reduction and related policy at the state and federal level. Even though cap-and-trade efforts have not gained significant political traction, the increased emphasis on sustainability is likely to influence decision-making and directly

impact their economic bottom-line. This has presented an opportunity for increased innovation in alternative low impact materials, and increased use of recycled materials and improved construction processes.

Within this context, a system like PE-2 intends to provide an easy to use web-based tool and a common platform to estimate project emission metrics and support sustainable decision-making. Contractors and state agencies can use these metrics to benchmark and monitor the life cycle emissions of products and processes associated with highway construction. In the end, it is expected that the metrics will provide the necessary justification for the use of alternative technologies, and have the potential for supporting decision-making at all levels.

It is important to note that the goal of the PE-2 platform is to support a decision-making method that accounts for project specific context and conditions, with the goal of reducing GHG emissions of the products, processes and services that define the pavement life cycle. The intention is not to compare and contrast alternative pavement materials, but instead, to promote improved decision-making, recognizing that the solutions for one project may not apply to another.

## References

- AsPECT. (2010). *Asphalt pavement embodied carbon tool (AsPECT)*. Retrieved March 30, 2011, from <http://www.sustainabilityofhighways.org.uk/>.
- Athena. (2006). *A life cycle perspective on concrete and asphalt roadways: Embodied primary energy and global warming potential*. Ottawa: The Athena Sustainable Material Institute.
- Bilec, M., Ries, R., Matthews, H. S., & Sharrard, A. L. (2006). Example of a hybrid life-cycle assessment of construction processes. *Journal of Infrastructure Systems*, 12(4), 207–215.
- Cass, D., & Mukherjee, A. (2011). Calculation of greenhouse gas emissions associated with highway construction projects. *Journal of Construction Engineering and Management, ASCE*, 137(11), 1015–1025.
- CAT (1999). *Caterpillar Performance Handbook*, Peoria: Caterpillar, Inc.
- CEPA (2006). *Assembly bill 32: Global warming solutions act*. Retrieved June 3, 2011, 2011, from <http://www.arb.ca.gov/cc/ab32/ab32.htm>.
- CEPA (2010). *Off-road emissions inventory*. California: California Environmental Protection Agency Air Resources Board.
- Chatti, K. (2010). Effect of Pavement Conditions on Rolling Resistance and Fuel Consumption. *Proceedings, Pavement Life Cycle Assessment Workshop*. California: University of California Pavement Research Center.
- EPA. (2004). *Unit Conversions, emissions factors, and other reference data*. US: Environmental Protection Agency.
- EPA (2005). *Emission facts: Average carbon dioxide emissions resulting from gasoline and diesel fuel*. Retrieved, from <http://www.epa.gov/oms/climate/420f05001.htm>.
- EPA (2006). *Life cycle assessment: Principles and practice*. National Risk Management Research Laboratory, US Environmental Protection Agency, EPA/600/R-06/060, May 2006.
- EPA. (2008). *Direct emissions from mobile combustion sources, climate leaders GHG inventory protocol core module guidance*. US: Environmental Protection Agency.
- EPA (2010a). *Greenhouse gas equivalencies calculator*. Retrieved October 30, 2010, from <http://www.epa.gov/cleanenergy/energy-resources/calculator.html>.
- EPA (2010b) Motor vehicle emission simulator (MOVES), version MOVES2010aUS Environmental Protection Agency.

- (EPA), U. S. E. P. A. (2010). MOVES2010 default age distributions (XLS).
- FHWA. (1999). *Preliminary evaluation of LTPP continuously reinforced concrete (CRC) pavement test sections*. Washington, D.C, US: Department of Transportation, Office of Highway Information Management.
- FHWA (2011). *Highway performance monitoring system*. Retrieved, from <http://www.fhwa.dot.gov/policyinformation/hpms.cfm>.
- FHWA (2011). *Sustainable highways self-evaluation tool*. Retrieved March 30, 2011, from <https://www.sustainablehighways.org/>.
- Frey, H., Rasdorf, W., & Lewis, P. (2010). Comprehensive field study of fuel use and emissions of nonroad diesel construction equipment. *Transportation Research Record: Journal of the Transportation Research Board*, 2158(-1), 69–76.
- Gallivan, F. (2010). *Greenhouse gas mitigation measures for transportation construction, maintenance, and operations activities*. ICF International. Inc.
- GDOT (2009). *2009 Vehicle classification by functional class, published by The Georgia Department of Transportation*. Retrieved from: [https://www.dot.ga.gov/informationcenter/statistics/TrafficData/Documents/ATRTrafficDataReports/2009\\_VehicleClassByFCandHour.pdf](https://www.dot.ga.gov/informationcenter/statistics/TrafficData/Documents/ATRTrafficDataReports/2009_VehicleClassByFCandHour.pdf).
- Guggemos, A. A., & Horvath, A. (2006). Decision-support tool for assessing the environmental effects of constructing commercial buildings. *Journal of Architectural Engineering*, 12(4), 187–195.
- Hendrickson, C. T., Horvath, A., Joshi, S., Klausner, M., Lave, L. B., & McMichael, F. C. (1997). Comparing two life cycle assessment approaches: a process model versus economic input-output-based assessment. *Proceedings of electronics and the environment, 1997. ISEE-1997., proceedings of the 1997 IEEE international symposium on*, pp. 176–181.
- Hendrickson, C., Lave, L., & Matthews, S. (2006). *Environmental life cycle assessment of goods and services: An input-output approach*. Washington: RFF Press.
- InfoTech (2009). *Field manager software*. Mysore: InfoTech Inc.
- IRF (2011). Calculator for harmonised assessment and normalisation of greenhouse-gas emissions for roads (CHANGER). Retrieved, March 30, 2011, from <http://www.irfghg.org/>.
- ISO (2006a). Life cycle assessment—Principles and framework. *Environmental management*. Geneva: International Organization for Standardization.
- ISO (2006b). Life cycle assessment—Requirements and guidelines. *Environmental management*. Geneva: International Organization for Standardization.
- MDOT (2003). *Standard specifications for construction*. Michigan: Michigan Department of Transportation.
- MDOT (2005). *Pavement design and selection manual*. Michigan: Michigan Department of Transportation.
- MDOT (2009). *2009 average daily traffic (ADT) maps*. Published by the Michigan Department of Transportation. Retrieved from: [http://www.michigan.gov/mdot/0,1607,7-151-9622\\_11033\\_11149\\_00.html](http://www.michigan.gov/mdot/0,1607,7-151-9622_11033_11149_00.html).
- MDOT (2009). *Various project proposals*. Retrieved, March 25th, 2011, from <http://mdotwas1.mdot.state.mi.us/public/bids/>.
- MDOT (2011). *Carbon footprint for hot mix asphalt and Portland cement concrete pavements*. Michigan: Michigan Department of Transportation.
- Muench, S. T., Anderson, J. L., Hatfield, J. P., Koester, J. R., & Söderlund, M. (2011). *Greenroads Manual v1.5.*, Seattle, WA: University of Washington.
- Muga, H., Mukherjee, A., Mihelcic, J., & Kueber, M. (2009). An integrated assessment of continuously reinforced and jointed plain concrete pavements. *Journal of Engineering, Design and Technology*, 7(1), 81–98.
- Mukherjee, A., & Cass, D. (2011). Carbon Footprint for HMA and PCC Pavements.” *Research Report RC-1553.*, Michigan Department of Transportation.
- Mukherjee, A., & Cass, D. (2012). Project emission estimator: Implementation of a project-based framework for monitoring pavement greenhouse gas emissions. *Transportation Research Record, Journal of the Transportation Research Board of the National Academies*, 2282, 91–99 (Washington, DC).



- Mukherjee, A., Cass, D., & Vana, J. (2011). *Project emissions estimator (PE-2)—A web-based highway construction project emissions inventory and emissions estimator*. Retrieved from, [http://www.construction.mtu.edu:8000/cass\\_reports/webpage/index.html](http://www.construction.mtu.edu:8000/cass_reports/webpage/index.html).
- Mukherjee, A., Stawowy, B., & Cass, D. (2013). Project emissions estimator (PE-2): Tool to aid contractors and agencies in assessing greenhouse gas emissions of highway construction projects. *Transportation Research Record, Journal of the Transportation Research Board, No. 2366*(1), 3–12 (Pavement Management).
- NREL (2009). “*US life-cycle inventory database*. US: National Renewable Energy Laboratory.
- PaLATE (2004). *Pavement life-cycle assessment tool for environmental and economic effects*. Retrieved from, March 30, 2011, <http://www.rmrc.unh.edu/Resources/CD/PaLATE/PaLATE.htm>.
- Peurifoy, R. A. O., G (2002). *Estimating construction costs*. New York: McGraw-Hill.
- Peurifoy, R. L. (2011). *Construction planning, equipment, and methods*. New York: McGraw-Hill.
- Consultants PRé. (2009, May). *SimaPro LCA software*. Retrieved from: <http://www.pre.nl/simaprof/>.
- Roadway Construction Emissions Model. (2011). Retrieved October 25th, 2010, from <http://www.airquality.org/ceqa/index.shtml>.
- Santero, N. (2010). *Life cycle assessment of pavements: A critical review of existing literature and research*. US: Portland Cement Association.
- Santero, N. J., Harvey, J., & Horvath, A. (2011a). Environmental policy for long-life pavements. *Transportation Research Part D: Transport and Environment, 16*(2), 129–136.
- Santero, N., Loijos, A., Akbarian, M., & Oschendorf, J. (2011b). Methods, impacts and opportunities in concrete pavement life cycle. *Report for Concrete Sustainability Hub*.
- SETAC (1994). “Guidelines for Life-Cycle Assessment.” *Environmental Science and Pollution Research, 1*(1), 55.
- Stripple, H. (2001). *Life cycle assessment of road—a pilot study for inventory analysis*. Gothenburg: IVL Swedish Environmental Research Institute.
- Truitt, P. (2009). *Potential for reducing greenhouse gas emissions in the construction sector*. A Sector Strategies Report, Published by the U.S. Environmental Protection Agency, Sector Strategies Program.
- UCPRC (2010a). *Pavement life cycle assessment workshop*. Retrieved April 4, 2011, from <http://www.ucprc.ucdavis.edu/p-lca/index.html>.
- UCPRC. (2010b). *UCPRC pavement LCA guideline*. Davis, Berkeley, CA: University of California Pavement Research Center.
- An online route planning & geo-analysis tool. Retrieved from <http://veloroutes.org/>.
- WashDOT (2010). *Washington state DOT 2010 sustainable transportation report*. Retrieved June 3, 2011, from <http://www.wsdot.wa.gov/SustainableTransportation/report.htm>.



# Chapter 4

## Anticipating and Responding to Pavement Performance as Climate Changes

Andrew Dawson

**Abstract** As climate changes, the performance of pavements can be expected to change too. More rainfall can be expected to lead to softer subgrades and less support to the pavement structure with consequences for more rapid cracking and rutting. Even if the amount of rainfall doesn't change, many places can expect the rain to fall in less frequent but more intense storms leading to challenges for current pavement drainage systems. If temperature rises, then asphaltic pavements may be expected to suffer from greater rutting in hot weather; but if the temperature rise causes greater evaporation then improved support conditions could arise; and if the temperature rise is in an area that historically experiences fully frozen conditions in the winter, then weak, thawing pavements could result. Predicting these and other effects of climate change involves an understanding of the sensitivity to climatic effects of both material properties and of overall pavement performance. In turn the predictions of such changes might indicate the need for adaptation in design, construction or materials selection—the extent of the need being dependent on the severity and risk associated with the predicted changes. In this way appropriate responses can be made to the challenges that future climate change will bring. In some places no change to practice may be required. However, for most authorities the immediate response should be to restate design codes and specifications with climate change in view. Mostly, the practices, techniques and tools for an adequate response are already available but users may need to employ adjusted practice if they don't want future maintenance demands to become excessive.

---

A. Dawson (✉)  
Nottingham Transportation Engineering Centre,  
University of Nottingham, Nottingham NG7 2RD, UK  
e-mail: andrew.dawson@nottingham.ac.uk

## 4.1 Introduction

Future climate change and its influence on the performance of the road network is an issue that is concerning more and more road authorities. This chapter seeks to give an overview of the anticipated changes in climate and their impacts on pavement behaviour. In many localities temperatures can be expected to rise and precipitation increase. Such changes can be expected to affect road performance in a negative way. To cope with these changes, present design, construction and maintenance practices may need to be amended.

## 4.2 Climate Change

### 4.2.1 What Is Climate Change?

According to Wikipedia (2013) “Climate change is a significant and lasting change in the statistical distribution of weather patterns over periods ranging from decades to millions of years”. Readers of the present document are probably interested in the decadal range and, in common usage, it is the progressive change in weather patterns that is usually referred to. At this point it is necessary, and important, to distinguish between weather and climate. Climate has to do with the long term average, seasonal distribution and annual variability of the weather, whereas a statement of the weather will need a description of the day-to-day temperature, wind, cloud cover, precipitation and so on.

Thus, even in an age of increasing mean global temperatures, and in a place on Earth where the local mean annual temperature is increasing, it is perfectly possible to have a year of cold weather. Indeed, if a climate change of increasing mean annual temperatures is associated with increasing temperature variability, then some years of colder weather should be expected alongside other years of warmer weather.

Although temperature is often the first issue to be considered when climate change is mentioned, it is far from the only issue to bear in mind. Increased global temperatures mean more energy in the atmosphere and warmer seas. These allow more evaporation of water to occur which leads to greater precipitation potential in many places, and allow more energetic winds engendering a greater likelihood of storms, in particular tropical storms. In general, but this may not be true of particular locations, the increasingly energetic atmosphere is expected to lead to more intense weather events (heavier rain and snow fall events, hotter hot weather and colder cold weather, drier droughts). Global temperature increase may also lead to climate redistribution. For example, coastal Californian winters are expected to be warmer and wetter yet its summers cooler (Lebassi et al. 2009; Neelin et al. 2013).

Climate change may also include change of distribution of weather across the seasons. Thus some locations might experience, on average, warmer winters and not warmer summers. In other places a wet season might, on average, become longer.

### 4.2.2 Why Does Climate Change Occur?

In the second half of the 20th Century it became increasingly obvious to scientists that the global climate was experiencing a steady increase in temperature, and that this increase was associated with increased levels of atmospheric carbon dioxide, CO<sub>2</sub>, and other gases that increase retention of solar radiated energy rather than reflecting it back into space. Collectively these gases have become known as greenhouse gases (GHG). Because CO<sub>2</sub> is the most common of these, they are usually quantified in “CO<sub>2</sub>equiv” being the mass of equivalent CO<sub>2</sub> (see Eq. 4.1):

$$\text{CO}_2\text{equiv (t)} = \frac{\sum(\text{Gas (t)} \times \text{GWP}_{\text{gas}})}{\text{GWP}_{\text{CO}_2}} \quad (4.1)$$

where GWP indicates the global warming potential of any particular gas or CO<sub>2</sub>, as appropriate, with masses being measured in tonnes (t). Most, but not all, scientific opinion attributes the increase in CO<sub>2</sub> to be the result of human activity (the burning of fossil fuels for heating, cooling and transport being the chief culprits). Hence, the associated climate change is termed “anthropogenic”.

Although, in general, particular climates will also experience rising temperatures, there will be considerable variation across the Earth. For example, greater arctic temperatures and consequent melting ice seem likely to cause the Atlantic Ocean Meridional Overturning Circulation (MOC) (known as the “Gulf Stream”) to slow during the 21st century leading to reduced temperatures in some parts of Europe. However, the consequent decrease in temperature there may be small compared to the warming caused by the much larger radiative effects of the increase in greenhouse gases (at least, until 2100).

The Intergovernmental Panel on Climate Change (IPCC) is the single most important source of information on climate change. Although it has been criticized in some quarters for being too political or technically biased, for most engineers it remains the first place to seek information on the topic. In the early 90s it made a prediction of future atmospheric CO<sub>2</sub> (Fig. 4.1) and this was instrumental in governments committing themselves to various CO<sub>2</sub> emission reduction actions. In May 2013 the Mauna Loa observatory in Hawaii first recorded mean global CO<sub>2</sub> concentrations at 400 mg/kg of the earth’s atmosphere (i.e. 400 parts per million by mass) which, as will be seen from Fig. 4.1, is towards the higher end of the predictions made more than 20 years earlier.

### 4.2.3 Predicting Future Climate Change

Figure 4.2 shows measured and predicted global mean temperature change from 1900 to 2100 (IPCC 1992) for different scenarios. As can be seen, there is a large range in the estimates for future mean global temperatures. In addition to the effects

**Fig. 4.1** Predictions of atmospheric CO<sub>2</sub> levels as made in 1992 (after IPCC 1992)

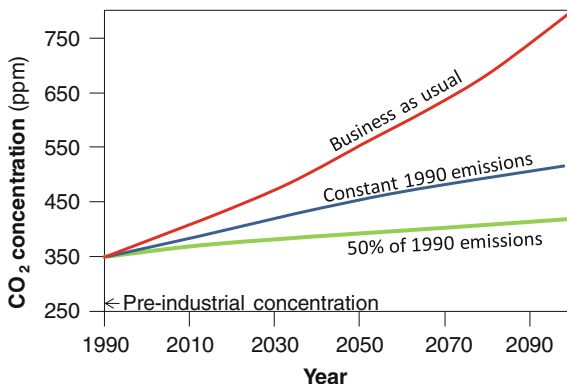

of the uncertainties about future green-house gas emissions, there are also many uncertainties in the science of prediction with some of the differences being due to the different theoretical and numerical models employed.

The most optimistic projection illustrated in Fig. 4.2 (B1) assumes an aggressive campaign to reduce CO<sub>2</sub> emissions while the most pessimistic is a “business as usual” scenario (A2), with other scenarios generally falling in between. Given the failure of society to limit GHG growth, and hence temperature rise, since nations

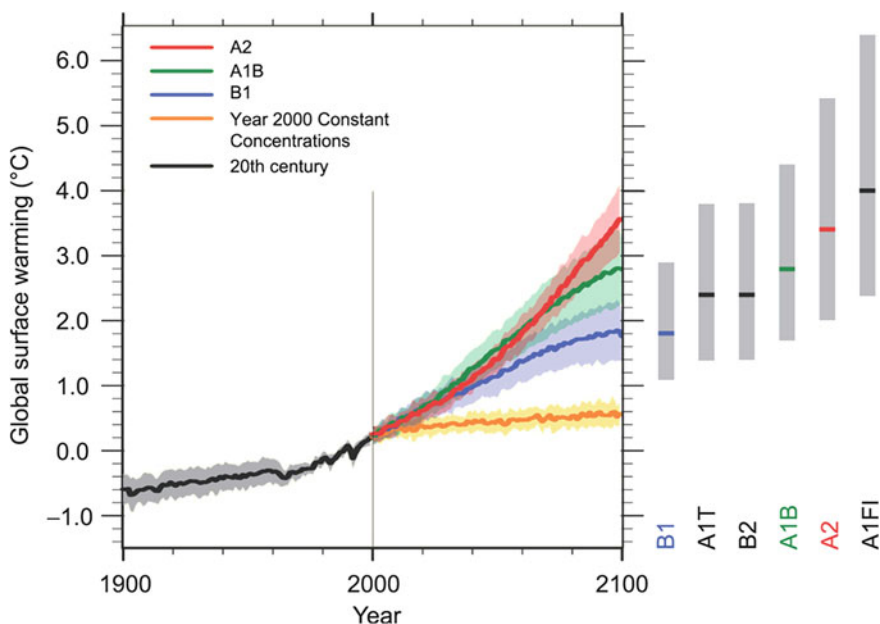

**Fig. 4.2** Historic and estimated future mean global surface warming 1900–2100 for differing green-house gas emission scenarios B1–A1FI (IPCC 2007). Grey bands indicate uncertainty of estimates

**Table 4.1** List of the main anticipated global climate-related changes

Most probable scenario	Quantification (by 2100)
Increase in temperature	1.1–6.4 °C
Increase of sea level	18–60 cm
Ice reservoirs melting	Not quantified <sup>a</sup>
Increased frequency and intensity of extreme weather events	Not quantified <sup>a</sup>
Increase in precipitation	Annual net in Europe: 0–15 % Annual net in USA: –20 to +20 %
Increase in radiative force	Anthropogenic: 0.6–6.4 W/m <sup>2</sup>
Increase of seasonally thawing layer thickness in high latitude soils	Not quantified <sup>a</sup>

<sup>a</sup> i.e. the effect is certain but the value has not been calculated reliably or varies too widely

began to be concerned about this (see Fig. 4.1) a pragmatic, conservative, engineering assumption for the foreseeable future may be to assume that climate change will continue to be associated with high estimates of future CO<sub>2</sub> emissions.

Taking the IPCC's data, mean surface temperatures will rise in the 21st century by between 1.1 and 6.4 °C with the probability, based on the foregoing, that the actual value will be nearer the top of this range than the bottom. The global changes are summarised in Table 4.1.

#### 4.2.4 Localizing Climate Change (“Downscaling”)

Even though there is uncertainty in predicting climate change at a global scale, road designers and owners need to know the change in climatic effect where their road is located. Thus global scale climate has to be localized, or ‘downscaled’. Again, numerical models have to be used, typically allowing climatic effects to be estimated over relatively large areas (perhaps 100 × 100 km or larger) for which climate is treated as being uniform. Software is readily available to provide this (e. g. MAGICC/SCENGEN (NCAR 2008)) but the reliability of downscaled predictions may not be as robust as required or, to state the same concern in a different manner, rather different downscaled predictions may be produced by different authors/methods.

Even so, micro-, or even meso-climate variations are not predictable by such methods, so local variations in climate due to topography, orientation to the sun, etc. will need to be handled outside of the broad localization calculations that are possible using generic software.

Because of the increased energy in the atmosphere, the amount of precipitation will probably increase at high-latitudes, while decreases are likely in most sub-tropical regions. Figure 4.3 shows these precipitation changes. In the Northern hemisphere, during winter, an increase in rainfall between 5 and 20 % is expected in

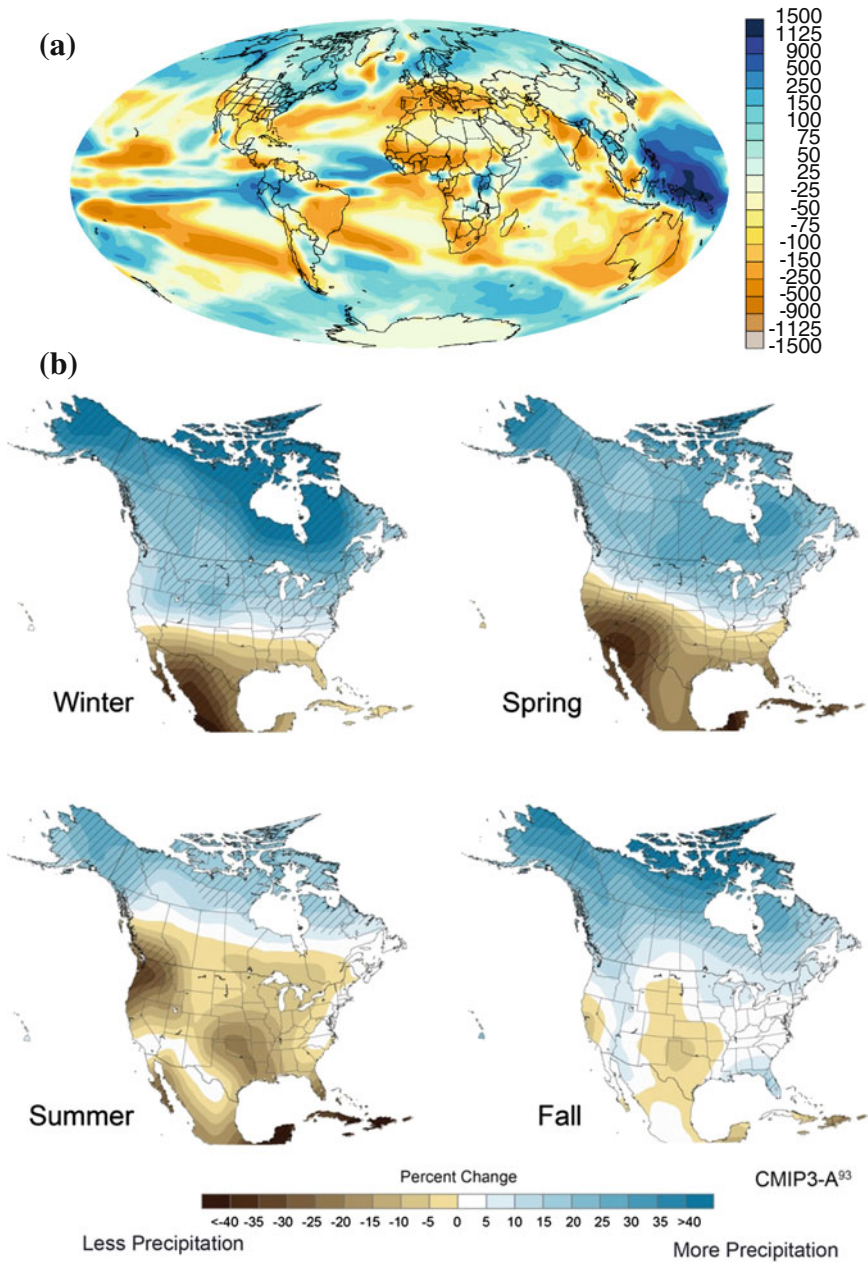

**Fig. 4.3** a Changes in global precipitation (in mm) over the 21st century (IPCC 2007); b Changes in N American precipitation (in %) over the 21st century (Karl et al. 2009)

the central-northern parts of Europe and much of Canada and the Northern USA, with reductions of the same amount in Southern Europe, the Southern USA, South-East Asia, Japan and North Africa. During summer, Scandinavian countries will see an increase in precipitation between 5 and 10 %, but the rest of Europe, North Africa, most of Canada and the US, Brazil, Southern Africa and Central Asia will have a decrease between 5 and 20 %. The seasonal differences can be easily seen in Fig. 4.3b. In Northern Climates the wetter winters act to counterbalance the summer drying, but in the some areas wetter summers and winters are expected (Indonesia for example) while in many equatorial areas both winters and summers can be expected to be dryer (e.g. the Caribbean, North Africa, Western Australia).

### 4.3 Induced Changes

Climate change will cause consequential changes to other aspects of the environment and it is doubtful whether all of these can be numerically predicted.

#### 4.3.1 *Water Levels*

Higher temperatures will lead to melting of ice masses on the Earth's surface which will cause increased sea levels—projected to be rise by 0.18–0.6 m in the 21st century, while more intense rainfall events can be expected to lead to more frequent flooding inland as larger volumes of water than in the past need to be transmitted through the same natural drainage pathways (streams, rivers, etc.).

Increased precipitation may lead to higher ground water levels, but this depends a lot on whether the increase is handled by sorption into the ground or by additional runoff. If increased rain falls in fewer, but more extreme, events then groundwater may fall. If summers are warmer then there may be greater evaporation or evapotranspiration causing groundwater levels to drop, at least seasonally.

#### 4.3.2 *Permafrost*

The IPCC 4th Assessment Report (IPCC 2007) also analysed the changes in frozen ground, which will mostly interest road owners in Alaska, Canada, Russia and the Northern zones of Europe. Permafrost has warmed in recent decades, mainly due to air temperature changes, but also due to secondary effects like a change in the insulation provided by snow (positive feedback). As an example, in the last decade the temperature of permafrost in Norway, at a depth of 15 m, has increased by about 0.3 °C. Thus there is a risk of permafrost degradation and even thawing due to the surface warming, with consequent ground surface subsidence. Typically, thaw

settlement does not occur uniformly, thus creating a chaotic surface with small hills and wet depressions called “thermokarst” terrain.

The thickness of the seasonally frozen ground (called “active layer”), i.e. the zone subject to freeze-thaw cycles, has been also monitored, demonstrating substantial inter-annual and inter-decadal fluctuations in thickness due to air temperature variations. In the last 60 years, there is evidence of an increase in active layer thickness and thermokarst development, indicating degradation of (warmer) permafrost (Brown and Coté 1992). In Eurasia, satellite images show that the date of thaw in spring became, on average, 5–7 days earlier and the date of freeze in autumn 5–7 days later, over the period 1988 to 2002 (Smith et al. 2004).

These climate changes will influence, somehow, many other different sectors, some of which can be, even if only indirectly, related to the road network. Among these there is vegetative growth, coastal erosion, ocean acidification and relocation of population and infrastructures.

### ***4.3.3 Vegetation Changes***

Climate change may lead to changes in vegetation and this may impact both groundwater levels and run-off. Warmer, dryer weather in already dry areas may lead to loss of ground cover allowing more easy erosion when rain does occur, allowing soil fines to wash into drainage systems.

### ***4.3.4 Traffic***

For many roads, climate change is likely to indirectly affect pavements to a greater degree than it will affect them directly. For example, demographic changes due to people’s desire to move away from low-lying flood-prone areas, from excessively hot climate areas, and towards areas where the climate has become more attractive, will change the sections of the pavement that are most trafficked. Responding to these induced changes in traffic pattern is likely to have a much greater impact on pavement maintenance and rehabilitation strategies than will (relatively) small temperature or moisture change over a particular period of interest.

In 2004, Austroads made a study aimed at investigating all the different aspects of the relationship between climate change and Australian roads. Using the scenarios produced by IPCC, they created 50 × 50 km maps of the continent describing monthly means of average, maximum and minimum temperature, precipitation, solar radiation, and potential and actual evaporation. The predictions show a land that is expected to become hotter and drier: annual temperatures will increase by 2°–6 °C by 2100, although not in a uniform way, but rather with more extremely hot days; for example, the number of days of winter days below 0 °C in Canberra is likely to drop from 44 at present to 6 to 38 by 2070. The Australian climate and



environment might be very different from other areas of interest to readers, and the problems they will encounter are almost certainly very different, nonetheless this study is very interesting because it includes a detailed description of the indirect impacts of climate change on road infrastructure. These indirect impacts are:

- Population and settlement patterns: fertility, mortality, and international and internal migration movements all influence the future network; for what concerns Australia, it is believed that coastal areas are likely to become more attractive, birth rate will decrease, while immigration will increase, and people will tend to move mostly in a few large cities. The same conclusions may not be applicable elsewhere, but the study does draw attention to the need to determine probable future “population patterns” for any area of interest.
- Road transport demand: it has been estimated that demand will increase mostly in those areas where population is expected to increase, with the proportion of heavy freight vehicles rising slightly and fewer vehicles transporting the same volume of freight. This means that, in Australia, average freight payload will rise by about 25 % from 2000 to 2100, and average ‘Equivalent Standard Axles’ (ESAs) per articulated truck will double due to higher axle mass limits. There may be a similar situation in many developed nations.

It is interesting to note the conclusions of the Australian study regarding the cities of Melbourne and Brisbane. In Brisbane, due to hotter summers, population will decrease by 4 % over a 100 year period compared to that which would be expected if climate remained constant. On the other hand, Melbourne will experience a warmer, and yet more desirable, climate. Accordingly growth in Melbourne will be 15 % greater than taking a non-climate change prediction. However, these have to be set against estimated population increases of 111 and 25 % respectively without climate change.

Thus the indirect, demographically induced, traffic impacts of climate change are expected to be significant (and almost certainly greater than the direct effects, at least in Melbourne), but even these effects are expected to be overtaken by the traffic induced by other factors (in Brisbane by a very large margin). Doubtless, these climate change-induced and population change-induced traffic effects will not be of the same order in other localities. But this data does help to put the effects of climate change into perspective.

The future increase in traffic has been also investigated by the U.S. Department of Transportation (2002), who predict that, by 2025, U.S. transportation energy use and emissions will be strongly influenced by the growth in light-duty trucks (pickup trucks, and vans, under 3850 kg gross vehicle weight rating). Also, according to the Federal Highway Administration’s Freight Analysis Framework, freight tonnage will grow by 70 % during the first two decades of the 21st century (US DOT 2002). Overall, these studies strongly suggest that climate-induced changes, though real, will likely be tiny compared to traffic change effects—whether or not that traffic change is due to population changes driven by climate change or by other demographic factors.

### 4.3.5 *Materials*

If changes in traffic loading indirectly caused by climate change need considering, so too will indirectly caused changes in materials availability. The desire to reduce fossil fuel consumption in order to limit climate change means that there is greater incentive to maximise the conversion of oil into fuel. This is leaving less oil from which to make bitumen. Therefore over the time-scales considered in this chapter it is possible that conventional bitumen might disappear, requiring pavement engineers to rely on recycled asphalt and/or biologically or agriculturally sourced bitumen replacements. As land to grow crops for fuel becomes in greater and greater demand, then an alternative scenario might be that flexible pavements as currently understood become replaced by (e.g.) pozzolanically—cemented pavements containing crumb rubber. There again, pressure to reduce burning of coal may restrict the availability of the most common pozzolan, coal fly-ash. Such ‘crystal-ball gazing’ is beyond the scope of this chapter, but these considerations of likely future constraints serve to show that changes in pavement behaviour due to climate change and the consequential response of design and maintenance engineers could turn out to be relatively unimportant.

## 4.4 Pavements as Climate Change Contributors and Mitigators

There are two types of responses to climate change, mitigation and adaptation. Most of this chapter is to do with adaptation—i.e. answering the question ‘how should a road owner adapt their practices to provide adequately performing and economic roads in the light of anticipated climate change?’. However, pavements may have a small role in generating and, potentially, mitigating (i.e. offsetting) climate change.

Like many man-made surfacings, pavements can act as solar heat collectors, assisting in increasing the Earth’s temperature. They are one of the contributors to the so-called Urban Heat Island (UHI) effect. Non-reflective surfacing (e.g. dark asphaltic pavements) will collect heat from the atmosphere, and particularly from solar radiation during daylight. Some experiments (Mallick et al. 2009; Bobes-Jesus et al. 2013) have been performed to exploit this characteristic and, in so doing, to obtain energy from a renewable source that would otherwise have been sourced from a fossil fuel source. To act efficiently, the pavement needs to be made of materials that will transmit the heat to the collector, and to have collector systems that are effective at transmitting that energy away from the pavement and to the point of use. Chapter 18 discusses these issues in detail.

Indirect structural solutions that reduce the pavement temperature are, however, more attractive. If water is stored in the pavement surface then warm weather will cause evaporation thereby lowering the pavement temperature compared to what it would otherwise have been, due to the consumption of latent heat energy. Some

initial research (Yamagata et al. 2008) into such a concept has been undertaken (e.g. in Japan) but is at its early stages. Another technique is to encourage greater reflection of solar gain by special surfacings (Li 2012). Both concepts are driven by the so called “Heat Island Effect” and not by pavement performance concerns. If pavements can be kept cooler so will the air around them. Thus urban populations, where there is a lot of paving, should experience less extreme summer temperatures leading to improved human health and comfort. Locally this will have a cooling effect although, globally, the wet-surfaced pavement simply moves water into the atmosphere for that heat to be released when the water condenses back to rain. Nevertheless, global benefit derives as less air conditioning use means less energy and, thus, less fossil fuel consumption and a consequential reduction in rate of greenhouse gas generation.

## 4.5 Response of Pavements

In this section are presented, in detail, the different effects that temperature and other climatic “triggers” can have on current roads. A final summary of the most likely future climatic changes that have been derived from the previous sections and the possible consequences on roads’ performance is listed in Table 4.2.

### 4.5.1 To Mean Temperature Change

Temperature is one of the main factors that affect asphalt performance. Its influence on the subgrade material is, instead, much smaller, almost negligible; temperature becomes of primary importance only when it is close to 0 °C, because, as will be discussed later, problems related to freezing and thawing can appear.

#### 4.5.1.1 High Temperatures

One of the main forms of asphalt deformation is rutting, caused by heavy traffic (especially when moving at slow speeds). At higher temperatures, the mastic is temporarily heated into a more plastic, deformable state. This has the effect of decreasing its binding strength and therefore, over time, repeated heavy loading will cause the mastic to thin and stretch. This takes on the appearance of grooves or ruts in the traffic lane, hence “rutting”.

Cracking due to thermal effects increases with aging-induced brittleness, therefore it is most related to hot climates, but it can occur in any climate. Large temperature variations between the day and the night or between summer and winter can also be detrimental due to daily, large strain extension and compression cycles.

**Table 4.2** Schematic of the main consequences to future road performance of likely climatic changes

Cause	Possible effects on highways	Effect
Increased mean temperatures in cold regions	Less pavement damage from frost heave	+
	More thawing periods with consequent loss of subgrade strength	-
	Ice roads unavailability	-
Increased mean temperatures in mild/warm climate zones	More evaporation leading to drier subgrades	+
	More rapid ageing increases embrittlement, with a consequent loss of waterproofing of the surface seal. Surface water can enter the pavement causing potholing and loss of surface condition	-
Increased extreme hot temperatures	Rutting	-
Rising sea level	Coastal erosion degrading the road platform	-
	Higher risk of floods	-
	Higher salinity may lead to debonding of asphalt and cement treated bases attack	-
Increased water availability during summer	Higher water table level, with consequent risk of lower subgrade modulus	-
Increased frequency and intensity of heavy rainfalls	Increased water on the road during or immediately after heavy rainfall events so pavement more susceptible to potholing and stripping	-
	Increase in subgrade moisture content reduces its stiffness	-
	Increased sedimentation/debris blocking water drainage system	-
	Inadequate culverts	-
	Erosion of road platforms	-
Increased temperature and rainfall variability	More difficult to plan and execute construction	-
	More difficult to plan and execute maintenance	-
	For extreme events, either more contingency/ reserve staff and equipment needed on standby, or must accept more losses because contingencies/ reserves aren't sufficient	-
Decrease of small rainfalls	Dryer environment	+
Higher solar radiation due to ozone hole	Reduction of asphalt stiffness, rutting	-
	Risk of oxidation = ageing	-
Increase in vegetation (in temperate zones)	Higher moisture content? in the near pavement zone	-
	Need for more maintenance	-
	More stability at the road sides?	+
Higher wind intensity	Traffic safety problems	-

(modified/supplemented from NIWA et al. 2004; Austroads 2004; Kinsella and McGuire 2005).

“+” = increased road performance, “-” = decreased road performance

### 4.5.1.2 Winter Climate

Whereas rutting and oxidation are problems more related to hot temperatures, thus they mainly affect roads in locations with hot summers, there are other effects that, in case of a global rise in temperature, can produce problematic subgrade responses in cooler climates, such as those of Scandinavia. In northern climates, long, cold winters usually freeze the ground, and this freezing draws water to the freezing front by a process known as cryo-suction, and this is associated with frost heave in the Fall loosening the freezing material. Once the temperatures rise again in the spring the ground will thaw. As the ground thaws from the surface down and bottom up, there remains a frozen layer in between that is effectively impervious. This means that the thawing soil above it is unable to drain and its moisture content increases as the ice melts, causing a severe drop in stiffness and bearing capacity.

If the road is then loaded for instance by a heavy truck, surface distress might occur. The phenomenon of the thawing is clearly explained in the following schematic (Fig. 4.4). For this reason, traffic boards in affected areas often set spring time traffic load restrictions for roads so as to reduce the damage (Van Deusen 1998, among others). However, if winter temperatures increase, thaw events could occur throughout the winter either necessitating long term load restrictions or, in their absence, permitting significant damage to the pavement.

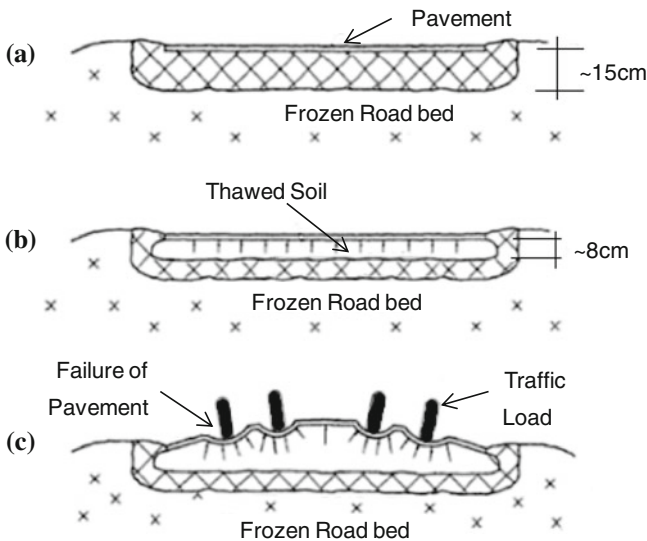

**Fig. 4.4** Process leading to damage of a road surface during a period of thawing (after Eigenbrod and Kennenpohl 1996): **a** Condensation during the fall creates ice-rich soil near the pavement base. **b** Excess water creates high pore pressure near pavement base. **c** High pore pressure reduces shear strength of soil, causing failure of pavement

A wetter Fall season in a frost-affected area can also be expected to be detrimental—providing a water supply to the freezing front so that more ice is available to melt in the following Spring.

### 4.5.2 To Changes in Solar Radiation

A distinction needs to be introduced between increasing levels of solar radiation and increasing temperature. Also caused by the changing climate, a variation in levels of solar radiation (World Resources Institute 2005) is usually accompanied by a similar variation in temperature. However, the two are not as strictly connected as one might think, because they depend on different factors, and different solar radiation values can be found in days with similar temperatures (and also vice versa). Figure 4.5 shows solar radiation and temperature data collected by the Fermilab Met Station during 1999. It can be observed that solar radiation is much more scattered than temperature, mostly because of the interaction of cloud cover. It can also be noticed that temperature trend is slightly delayed compared to that of the solar radiation, because temperature is mostly a reaction to solar radiance.

Although high temperatures aid in oxidation and, hence, premature asphalt aging, it is solar radiation which is the main driving force behind the process (Milani and Takallou 2009). In the process, a chemical reaction is undergone that combines elements within the bitumen with oxygen molecules in the air. This process may break long-chain molecules (dependent on the binder used) as well as increasing the viscosity of the mastic over time due, in part, to volatilization of solvent-type molecules. As brittle binders cannot tolerate the highest stresses, this leads to the onset of micro-cracking and later on more pronounced stress cracks will begin to appear. These are often referred to as “alligator cracking” or a series of interconnected cracks that form a pattern similar to an alligator’s skin.

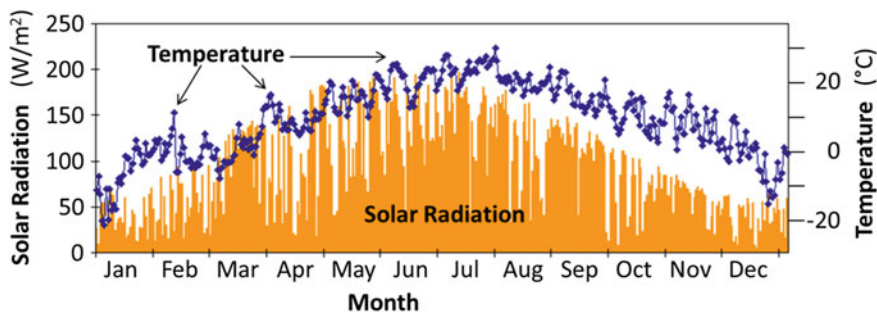

**Fig. 4.5** Comparison between solar radiation and air temperature (from Fermi National Accelerator Laboratory 1999)

### 4.5.3 To Mean Precipitation Change

Precipitation is another factor that can strongly affect the road's performance. While temperature mostly influences the asphalt layer (although it is of paramount importance for the subgrade when it is within a range that can cause thawing), water is one of the main reasons that can bring the subgrade to failure. This is because a change in precipitation can change the soil moisture content, and, thus, its modulus.

Simulations described in more detail in Sect. 4.6.3 showed that, in general, a relatively small change in rainfall pattern, i.e. average intensity and duration, not accompanied by increase in yearly amount of rainfall water, does not seem to affect sensibly the saturation level of the road structure. More extreme intensities or large changes in rainfall quantity can instead be an issue, as sub-base saturation increases to dangerous levels. As can be expected, clayey soils are the most problematic.

One of the most likely responses of asphalt to increased moisture content is loss of aggregate-bitumen bonding which can lead to *ravelling* and *cracking*. It results from a combination of aged brittle asphalt and standing water within the voids. Here, as traffic passes over the surface, compressive forces generate pressure, pushing the water up and out of the asphalt. As it leaves, this water will break some of the more brittle bonds between the aggregate and mastic, leading to aggregate-free asphalt patches on the road surface, and thus to a reduced grip for the vehicle. Surface water can enter the pavement causing potholing and loss of surface condition. Although ravelling can also be caused by premature aging of the asphalt, it is thought that standing water within the asphalt, as well as drainage patterns within traffic lanes, have a higher probability of causing ravelling damage (Wolters 2003). Maintaining asphalt quality in the light of climate change is also important as the asphalt provides the front line of defence against water ingress into underlying layers where, as will be shown, it can be very disadvantageous.

But probably the most important problem caused by excess precipitation is *base and subgrade destabilization*. In this situation, if water is not properly drained away from the road as it seeps through the asphalt and base layers, it can drain into the subgrade layer and increase the moisture content, causing the stiffness of the base and lower layers to drop. Also, it can cancel the positive effect of the suction very rapidly. Therefore, as traffic passes over the road above, it will not be the base and subgrade taking the stresses (as designed) but rather the thin asphalt binding and wearing course. This obviously leads to overstressing and cracking of the asphalt pavement. To avoid this, the drainage path for road runoff must prevent the base and sub-base layers from becoming too waterlogged. However, with the onset of higher intensity, shorter duration rainstorms, previous drainage designs may no longer be adequate (see Sect. 4.5.5.1).

A concern of many northern areas that experience harsh winters is the significant increase in winter precipitation. Depending on weather conditions, several responses to this might be seen. If a warmer winter occurs that fluctuates between extended periods of freezing and non-freezing air temperatures, rain could fall on to frozen roads causing *premature thawing* and destabilization of the road base as

discussed in Sect. 4.5.1.2. However, in a cold winter climate with only a few days above freezing, rain falling on those days could sink into the asphalt and freeze overnight. In this case, the water in the voids of the asphalt would expand as it froze and break apart the aggregate from the binder causing a combination of a cracking and ravelling effect. Also water held in the subgrade, in case of freezing, can *heave* and thus crack the asphalt surface above.

The water table below the road can change due to two main reasons: one is the sea level change due to the melting of ice, and the other is the change in precipitation. However, as the environment is a complex system, the groundwater table may be, in turn, be affected by many other factors. It is well demonstrated (Hall and Rao 1999) that a strong relationship exists between the groundwater table and the subgrade moisture content; if sea levels and/or rainfall tend to increase, as is expected, so too will the water table. It should be noted that, while precipitation is highly dependent on the geographic and topography, and the changes predicted still suffer uncertainty, the future sea level increase is almost certain. Higher water tables tend to increase the moisture content of the soil above, and also capillary action will increase the moisture content of pavements and decrease the suction force of the unsaturated zone, thus decreasing its modulus and accelerating the rate of pavement deterioration (Austroads 2004). Groundwater table becomes more and more important as it gets shallower, and, when close to the surface, it is the main factor responsible for determining the subgrade moisture content (Hall and Rao 1999).

#### ***4.5.4 To Extreme Temperature Events***

Extreme temperature and rainfall events are expected to become more common, though prediction of their prevalence does not appear to have been successfully attempted, as yet.

##### **4.5.4.1 High Temperatures**

According to Zuo et al. (2007), whenever average pavement temperatures are used to determine the asphalt stiffness, pavement life is overestimated (see also Kameyama et al. 2002). This is partly because asphalt softening also permits faster rutting and because less load spreading consequent on loss of stiffness leads to stress and strain increases inside the pavement—potentially causing cracking. Such overestimation of pavement life can even reach the 50–75 %. Thus, ‘higher-than-average’ and extremely high temperatures will have a disproportionate impact on pavement performance. For this reason, increased ‘heat waves’, though brief, may become very significant factors in reducing flexible pavement life.



#### 4.5.4.2 Cold Temperatures

Extreme cold spells, though perhaps not as likely as ‘heat waves’, can be expected to promote cold temperature cracking of asphalts in addition to their more general contribution to the freezing of the ground as discussed previously.

### 4.5.5 To Extreme Precipitation Events

#### 4.5.5.1 Heavy Rain

Higher intensity rainfalls and storms can lead to two main problems: the *erosion* of the road platforms or land adjacent to the road and the *blocking of the drainage system* due to the accumulation of debris (see Fig. 4.6). If rainfall remains similar but falls more heavily less often, then vegetative ground cover alongside the road may become less. Then, when heavier than past rain storms occur, the heavy rain may be able to wash soil onto the road surface and into drainage gullies rather easily. Also worth mentioning is the concern over improperly designed drainage culverts under roads. If these become inadequate to carry flows of future rainfall run-off events, then serious destructive damage can result.



**Fig. 4.6** Excessive run-off/seepage eroding the top of a drain following heavy rainfall (courtesy of Antero Nousiainen)

### **4.5.5.2 Heavy Snow**

While rain is of concern, heavier snow, occurring less frequently, can be expected in some countries in winter leading to the need for more competent winter maintenance equipment and operation teams which will be used less—with considerable economic consequences due to investment in inventory and training which is held ‘just-in-case’.

### **4.5.5.3 Drought**

Drought may be rather beneficial as it will usually be effective at lowering water tables and thus lead to a stiffening of pavement support conditions in the subgrade. However it could also result in plant die-off so that rain after a drought may be more destructive.

## ***4.5.6 To Other Climate-Induced Effects***

### **4.5.6.1 Flooding**

Locally, increased intensity of rainfall combined with current drainage provision is likely to result in greater surface water collection in low spots, leading to flooding. Such floods will provide large volumes of water to soak into pavement structures while preventing drainage layers from functioning until normal water levels are re-attained. Thus flooding can be expected to give rise to post-flooding soft-spots where pavement deterioration in the form of asphalt stripping, rapid fatigue cracking and structural rutting can all be expected to become much more prevalent.

Erosion of culverts, drainage ditches and other parts of the drainage system can be expected to occur when large flows are generated, thereby undermining road edges and culvert entrances and exits.

### **4.5.6.2 Sea Level Rise**

On the coast, low-lying roads may experience rising water tables as a consequence of rising sea levels. Rising groundwater levels will lead to reduced pavement support and greater risk of structural rutting. Unlike other pavements experiencing higher groundwater levels, the vertical proximity of the sea may make extra drainage an untenable solution. If the groundwater is saline then issues of durability of the pavement materials may arise.

### 4.5.7 Overall Impacts

While there seems little doubt that climate-induced impacts will be experienced by pavements, the time-scale for these impacts is relatively large compared to common pavement design lives. In the foregoing sections the time-scale of the changes under consideration was of the order of 90 years, whereas pavement engineers would only expect so-called “perpetual pavements” to still be in-service over this time-scale. Many pavements can be expected to have gone through 2 or even 3 full-scale reconstructions in that time period. Therefore, many of the potential impacts may not be experienced in practice before reconstruction takes place. Thus, at that time, appropriate features can be included in the reconstructed pavement to respond to the slower changes of the climate.

Computations performed as part of the P2R2C2 project (Hoff and Lalagüe 2010) used the AASHTO Mechanistic Empirical Pavement Design Guide (MEPDG)/Pavement-ME Design to compute pavement life and other characteristics for current and future climates at 6 locations across Europe from Northern Finland and Norway to Croatia and Atlantic France to Continental Poland. These exploited similarities with climates from Alaska to California and from Washington State to Montana. These studies aimed to incorporate the composite effect of temperature and precipitation change. The effect of increases in temperature of between 2 and 9 °C and precipitation changes of circa  $\pm 25\%$  were studied.

Three different pavement structures were analysed having between 5 and 36 cm of asphalt each over a 25 cm granular base. As a general rule, top-down cracking was very significantly increased when temperature increased with permanent deformation of asphaltic layers also showing large increases, although a little less, proportionately, than top-down cracking. Thermal cracking significantly reduced in locations currently experiencing cold winter climates. The MEPDG has no mechanism linking rainfall to moisture content in base and subgrade layers, so the P2R2C2 researchers reduced the modulus in these layers in line with estimated changes in moisture content (Bizjak 2010). For the thin structure a circa 25% increase in rainfall caused large increases in asphalt cracking because of the increased flexing of the aggregate and subgrade layers consequent on their lower stiffness, along with small increases in rutting due to increased permanent deformation of these lower layers. For the thicker pavements, effects of increased water content in the lower layers were much smaller.

Qiao et al. (2013b) also used the MEPDG software and made predictions of changed response for a pavement in Virginia, USA with 19 cm of asphalt over a 13 cm thick granular base and a 15 cm thick sand sub-base. Taking the three IPCC scenarios A1FI, A1B and B1 over a 40 year period, they obtained temperature rises of between 1.26 and 2.02 °C and precipitation increases of between 5.3 and 1.72%. As this was a road near sea level the authors assumed an equal rise in groundwater level as in predicted sea level rise of 13–16 cm—from a depth of 1.5 m.

Rather than compute the impacts directly, the authors separately considered a 5% change in the parameters of temperature, precipitation, wind speed, solar

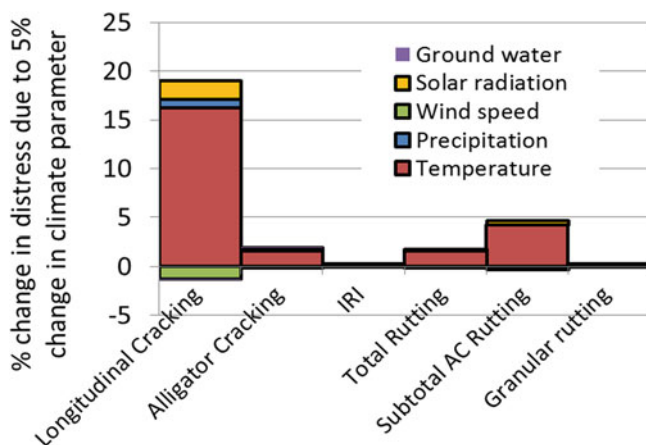

**Fig. 4.7** Sensitivity of Qiao et al. (2013b) Virginia pavement to MEPDG environmental factors (IRI = International Roughness Index); 5 % increase in groundwater level means depth is reduced to 95 % of previous value; 5 % increase in temperature means 1.05 times the previous temperature greater than  $-18^{\circ}\text{C}$

radiation and the ground water level. Their results are presented in Fig. 4.7. As can be seen, it is temperature that has the greatest effect and, with regard to longitudinal cracking, its effect is disproportionately high compared with the change in input. Other researchers (Kim et al. 2005; Hoff and Lalagüe 2010) have also made a similar observation. However this tendency is not expected for thin asphalt pavements in a warm climate (Hoff and Lalagüe 2010). In addition, it has been found that the layer thickness and modulus of the base has a significant influence on longitudinal cracking in the MEPDG (Graves and Mahboub 2006; Masad and Little 2004). These observations raise questions about the longitudinal cracking model in MEPDG (Hoff and Lalagüe 2010) that cannot be answered here, but suggest, at best, that the sensitivity of longitudinal cracking to temperature change in any other pavement structure might be significantly different. At worst it suggests that the sensitivity of longitudinal cracking to temperature change cannot be estimated using the MEPDG.

Overall, Qiao et al. (2013b) noted that although an increase in temperature tends to accelerate pavement deterioration, the impact was rather small for the chosen road, e.g. increased rutting over 40 years under the high emission scenario was predicted to be only 1.4 mm. However, this seemingly small increase may lead to a significant reduction in service life and earlier intervention maintenance (Qiao et al. 2013a). This is because of the way deterioration develops—quickly in the early stages then more slowly later on. Thus, if the intervention value of a particular measure is only reached late in the pavement’s life, a small change in that value could be associated with a large change in life (see Fig. 4.8). Conversely, a modest change in value of the intervention criterion would mean no need for any change in maintenance regime.

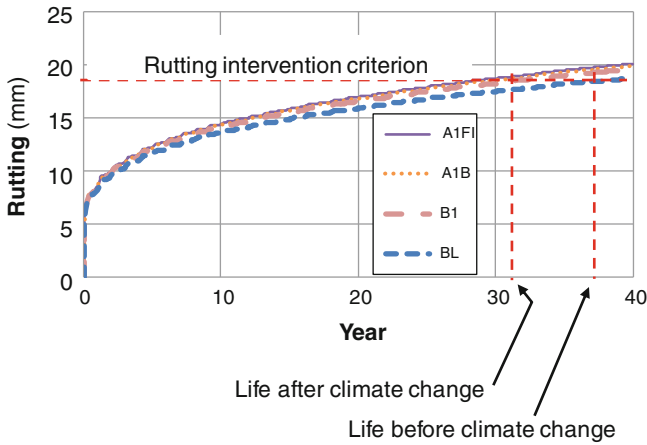
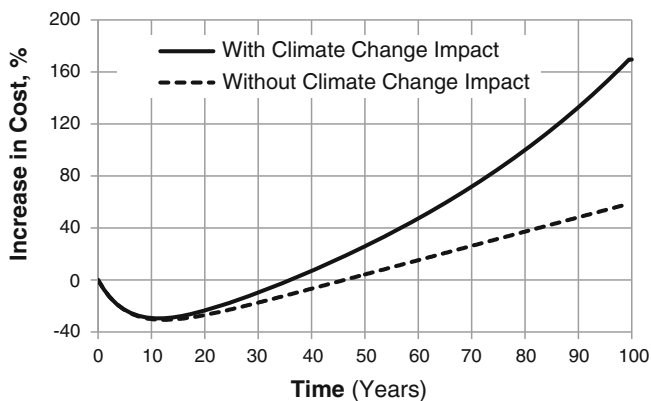

**Fig. 4.8** Sensitivity of Pavement life to small changes in deterioration (Qiao et al., in press) A1FI, A1B and B1 indicate IPCC predictions. BL indicates Baseline—i.e. current climate

Qiao et al. (2013b) determined that the distresses that are most influenced by temperature increase are longitudinal cracking, alligator cracking and (asphalt) rutting, while roughness (measured as IRI) and permanent deformation in unbound granular materials and subgrade are less affected. However, this is based on an overall sensitivity which is calculated using overall climate change and total distresses at the end of its design life. Thus this sensitivity will almost certainly not apply for a specific season/month/day.

Qiao et al’s studies were unable to fully address the impact of extreme events. Those authors identified high temperature and high solar radiation days as needing further study so as to increase the reliability of estimates of climate change in general and temperature in particular. Mallick et al. (2014) used a system dynamics approach to investigate the impact of climate change on pavement performance and maintenance costs—an approach that, in part, appears to allow the impact of extreme events (in these authors’ case the effects of changes in air temperature, rainfall, sea level rise and number of Category 3 hurricanes were incorporated). Figure 4.9 shows their estimate of increased costs as a result of climate change over that which is anticipated due to a constant climate.

The marked difference in findings between Mallick et al. (2014) and the earlier studies appears to be due to the incorporation of localized, extreme damage in the later predictions. So, taking all the research together leads to the implication that a large proportion of the network will not be damaged very much more than at present under the anticipated changes in climate, but there will be a few segments that will be damaged significantly more than is expected under the current climate regime and the economic consequences of that damage will be significant.



**Fig. 4.9** Estimated increase in pavement maintenance costs with and without climate change for some New England pavements (Mallick et al. 2012)

## 4.6 Adaptation

Where the deleterious impact of climate change on the pavement is such that change in engineering practice is warranted, there are several response options available to combat or ameliorate those impacts. Broadly these can be divided into changes to material selection, changes to design and construction (here covered in terms of structural and drainage modification) and changes to maintenance response.

### 4.6.1 Adapting Materials

As indicated above, many pavement materials have mechanical properties that are sensitive to environmental conditions, principally temperature and water content. With increased temperatures, asphaltic materials with harder binders may allow easy adaptation of pavement materials to climate change such that no net change in bituminous pavement behaviour occurs. Because the period of pavement replacement/rehabilitation is no longer, and often shorter, than the period over which climate change can be expected to cause a statistically detectable change in mean weather pattern, upgrading the binder may be a very effective way of dealing with higher mean temperatures as it will be able to address the additional deterioration, even under a high warming hypothesis (A1FI). Nevertheless, the costs associated with the binder upgrade may be rather high. Even if the unit change in cost of binder is low, the total costs for upgrading a road network can be high, considering the large areas involved.

However, if a greater range of temperature over the course of year is anticipated (and the increasing probability of short-term extremes of temperature suggests this eventuality), then a simple change of binder will not be the solution. Instead, binder

property manipulation may be needed, e.g. by the user of polymer modifiers, so as to give greater high temperature stiffness while not losing cold temperature ductility. Reinforcement of asphalts using polymeric grids is feasible, though probably not cost effective.

The lower parts of the pavement are often unbound. But their unbound nature doesn't indicate permeability. Indeed, graded unbound materials are often rather impermeable. With greater intensity rainfall events and, in some places, higher water tables, there could be a need to provide more permeable, drainable bases. Open graded drainage layers (OGDLs) have been in use for a long time, but haven't garnered a glowing reputation (Winkelman 2004; Hall and Correa 2003). So there is some uncertainty as to how to produce effective drains that act as good lower pavement layers unless they are first treated with Portland cement, bitumen or other binder—in effect producing weak no-fines concrete or porous asphalt, but as lower pavement layers.

### ***4.6.2 Adapting Structures***

A separate discussion has to be made for those areas that are geographically closer to the sea (Austroads 2004). Here, coastal erosion and floods can accelerate the degradation of the coastal platform. Also, a more elevated water table can create the problem of increased salinity. In hot climate areas, where evaporation is significant, water from the water table flows upwards in order to replace the water evaporated. This event can lead to a water movement upwards tens of metres above the phreatic surface and it can also lead to salts being lifted to the surface where they can affect the soil properties. It was shown by Chan (2001) that an increase in the salinity can have a significant impact on road systems, as it has the effect of hardening the bitumen and causing brittle cracking and even potholing. Salinity can also affect subgrade that has been treated with binders such as cement, and salt rusts the reinforcement in concrete structures.

As already discussed previously, the change in climate in Northern areas may lead to particular difficulties. There will, likely, be a loss of guaranteed frozen pavements during winter associated with a single, problematic spring thaw. This will be replaced with on-going near-surface freeze thaw cycles of several weeks. Unsealed roads have functioned well in the past, except during the thaw period. In the longer-term future they seem likely to perform less well over most of the winter, to suffer little or no traumatic spring thaw event and to exhibit their summer behaviour for longer (with associated dust problems). Countries to the south (northern Poland/Germany) which currently experience the type of weather which may be experienced in south/central Nordic countries in future rely on binding of the upper pavement layers (and associated post-winter maintenance) to see them through this type of climate. Therefore stabilisation of the upper, currently unsealed, pavement layers seems likely to be needed in future. This could be costly. As some recompense, major highways in the northern areas have frequently been

built on large thicknesses of crushed granular material so that the frost penetration never reaches deep enough to cause heave (and hence allow later thaw) of the subgrade. This thickness can be progressively reduced in future designs.

### 4.6.3 Adapting Drainage

2D numerical simulations were performed as part of the P2R2C2 project (Carrera and Dawson 2010) using a cross-section of a typical pavement substructures. Four models of roads were simulated: a typical European highly trafficked road, a road surfaced with porous asphalt, a low-volume traffic road and a highly cracked road. The cross section of the first of these is illustrated in Fig. 4.10. Because the pavement cross-section is symmetric, only half of the structure was modelled (see dashed lines in Fig. 4.10).

In order to maintain low saturation levels on the pavement structure it is essential to provide proper lateral subsurface drainage. This is constituted by a pipe at a level below the bed of the sub-base, where water can be collected, and by a draining aggregate that allows water to be conveyed from the adjacent soil, the surfaces and from around the sub-base into the pipe. The importance of applying, around the lateral drain, a geotextile able to allow water to pass through but to limit fine material from intermixing with the lateral draining aggregate was shown through the simulations.

A well-constructed, high volume traffic road with a surface that does not show cracks, was shown to be able to handle quite well changes in rainfall intensity and quantity. This stresses the importance of taking action promptly as soon as crack damage appears on the surface, or even before. The simulations show that the presence of a surface lateral drain, however, is going to be more and more important as future rainfall events are likely to be more extreme and thus a greater amount of

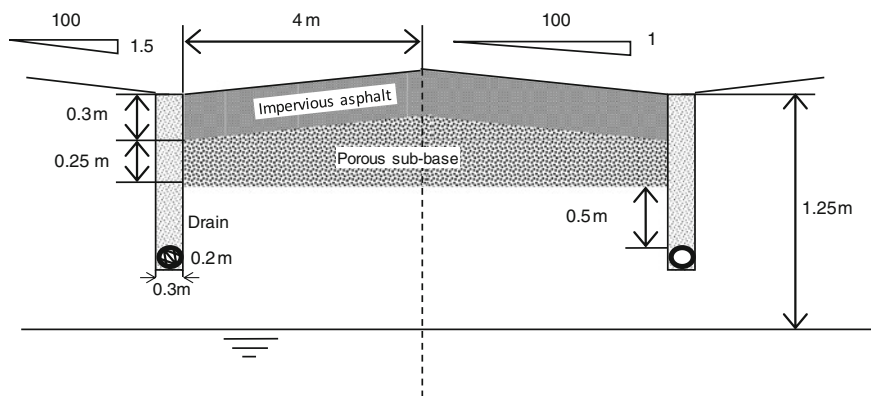

Fig. 4.10 Schematic of the high-volume traffic road simulated



runoff water will need to be conveyed and removed from the road surface to avoid flooding.

Also, porous asphalt seemed to perform well as a surface course even in the presence of intense rainfall patterns: only a slight increase of saturation level in the porous asphaltic layer on the sides of the road could be observed, with saturation not reaching the surface, while the sub-base did not show any significant increase in saturation level. Therefore, it seems to be a good option by which to remove free surface water during storms. Such pavements must be equipped with an impervious layer directly beneath the porous asphalt, and that layer must not be susceptible to cracking, otherwise the system will serve to introduce water into the pavement—the very thing which the drainage system should be aiming to avoid.

An issue that is likely to become more important in the future is the presence of a high water-table below the road structure; in this case, the saturation of the sub-base can reach levels that can considerably decrease the strength of the aggregate. When the water-table is shallow, the saturation of the sub-base is rather high, independently of the amount of rain falling. In these cases, an impermeable geotextile placed between the sub-base and the subgrade, coupled with a draining layer to let water flow from the subgrade into the lateral drain, seems to give very good results.

As for the previous cases, a secondary road, subjected to the same kind of analysis, did not seem to be particularly affected by medium-small changes in rainfall intensity, nor by changes in rainfall total quantity on a year. Again, it's the extreme cases that make a large difference. In these cases, a high level of saturation can be reached in the sub-base. The thickness of the sub-base layer does not seem to improve the situation though: even a thick layer can reach relatively high saturation levels; although, the presence of a thicker sub-base tends to increase the flow of water beneath the road surface.

The P2R2C2 project also determined that a cracked pavement surface is an issue for the stability of the sub-base independently of the rainfall intensity, as its water content tends to increase in all circumstances to dangerous levels, and the situation gets (obviously) worse in extreme cases such as heavy rainfalls. An inclined sub-base bed aimed at helping the outflow of the water towards the lateral drainage brings a slight improvement, but, as saturation is still too high, it cannot be considered as the only precaution to be taken. Also a thicker layer seems to bring some benefit, but again the difference is not very significant. Therefore, the coupling of a thick sub-base with an inclined bed is suggested along with greater permeability achieved, e.g., by stabilised open-graded materials (see Sect. 4.6.4).

Self-flushing and easily inspectable drain runs need to be constructed, too so that maintenance becomes much more practicable than at present (see Sect. 4.6.4).

Where changes to drainage systems are needed these should be considered for the next major rehabilitation of the pavement structure. It will be cost-prohibitive to make changes to deep pavement layers at any other time, and even provision of more permeable lateral drains and new porous surfacing (and the connected outfalls) will be beyond a simple inlay or overlay budget for most authorities.

It is not only internal drains that are of concern, the capacity of existing culverts and waterways may also prove inadequate and checks on capacity, particularly for

extreme events, must be performed. Adapting culverts for increased flows could, however, be extremely costly given that they may be at some depth beneath the road surface.

Because higher water tables can accelerate the rate of pavement deterioration due to capillary action with consequent increasing of the road subgrade moisture content, road agencies may sometimes need to raise the levels of existing embankments when pavements reach the ends of their useful lives.

Future designs for pavements and drainage systems will need to predict such changes and make adjustments to the construction (higher pavement levels, highly permeable underdrains, etc.). More generally, the need for better functioning drains and the possibility of raised water levels at outlets could cause local problems of inadequate falls along drainage runs. Therefore higher construction of pavements in low-lying areas is preferred.

#### ***4.6.4 Adapting Maintenance***

The Austroads (2004) project outlined some maintenance issues for the future:

- An increase of pavement maintenance and construction costs if the climate tends to become wetter.
- An accelerated rate of deterioration of seal binders where temperature increases, necessitating earlier re-application of surface dressings and seals.

Qiao et al. (2013a) predicted a significant budget increase for maintenance if current pavement construction and maintenance criteria and practices are continued, partly because of the sensitivity of intervention requirements to small changes in deterioration consequent on climate change. Furthermore, additional road user costs (particularly fuel consumption due to higher rolling resistance) might occur due to more rapid development of road roughness. In a successor paper, the same authors, using data from other pavements (Qiao et al., in press) indicated that, without maintenance, climate change will likely increase the user costs, although the increase would be not significant. Their study also showed that the impact on maintenance costs was very dependent on maintenance strategy.

With minimum maintenance, climate change may have significant impact on road maintenance planning. For the structures studied, treatment was necessitated 8–16 % earlier due to climate change, corresponding to an increase of approximately 1–2 % Net Present Value for agency costs. However, total Life Cycle Costs (LCC) might then be reduced if the earlier maintenance increased the average serviceability in the long term and thus reduced the user costs significantly as these usually dominate the total LCC.

For the example pavement they studied, and probably for many others, minor adjustments to maintenance trigger values could remove the need for any change in maintenance strategy and hence climate change would have no effect on costs.

### 4.6.5 *Adapting Standards*

In an article by Kinsella and Mc Guire (2005), the authors study the impact of the climate changes on the state highway network of New Zealand. The most significant effects are the rising sea level that causes coastal erosion, thus degrading the coastal platform, and the increase of coastal floods, which affects the maintenance of the roads nearby. The reduction of frost during winter reduces the pavement damage due to frost (which means less need of maintenance), but also increases the vegetation (which might be an issue instead). Increased heat during summer brings more rapid ageing of pavement. While in the west of the island an increase of rainfall is expected, with consequent increase of erosion and risk of landslides, in the east the rainfalls are supposed to reduce, leading to a minor need of maintenance. Finally, high wind gusts may affect traffic safety. They identified the most potentially vulnerable asset types to climate change impacts to be bridges, culverts, coastal roads, pavement surfaces, surface drainage and hillside slopes. Not all of these are of primary interest for this chapter, however, the two-stage assessment process used by these authors to identify those areas requiring action can be very useful:

- Stage 1: Assess the necessity of acting in the present to manage future potential climate change impacts (this depends on the level of certainty that the impact will occur to the magnitude predicted, the intended design life and the capacity of current practice to manage the climate change impact, see Fig. 4.11);
- Stage 2: Assess the feasibility of acting now to manage future potential climate change impacts (mostly related to the costs).

Three key approaches were analysed:

- The “do nothing” approach, which consists of continuing to use the current design specifications.
- The “total retrofit” option, which consists of retrofitting all potentially affected roads now to avoid future climate change impacts.
- The “future design” option, which consists of repairing the road when required, and in the meantime designing all new highways to accommodate future climate changes to 2080.

Taking the design of a bridge as an example, the analysis showed that, if the ‘Do Nothing’ option is considered, the annual costs of maintenance could increase by a factor of two for any 1 year; the cost of the ‘Total Retrofit’ option, whilst small in relation to the replacement cost of state highway bridges and culverts if no action is taken, is nonetheless significant. Thus, the results showed that the best solution was to repair the asset at a time when the specific loss or need became evident, as current asset management practice seems to be adequate to cope with most predicted climate change impacts.

For pavements, where the life cycle of a pavement surface (in civil engineering terms) is relatively short (e.g. 20 years), weather changes due to climate change are very unlikely to increase or decrease the pavement deterioration process in a

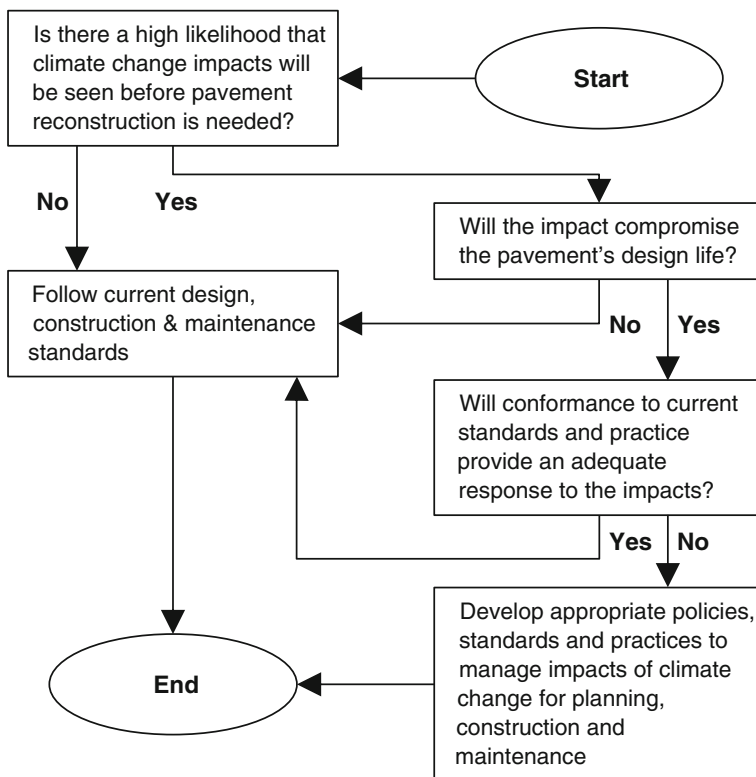

**Fig. 4.11** Initial climate change impact assessment framework (after Kinsella and McGuire 2005)

non-negligible way during that cycle. Non-negligible impacts are anticipated over a longer time-scale. Therefore the “future design” option will usually be the best. As the climate evolves, newly-built and substantially reconstructed roads should be designed and constructed taking into account up-to-date climate-related factors as well as traffic factors.

The exceptions are “perpetual” pavements. These pavements are expected to function, with only small maintenance interventions at their service, for more than 50 years. In future such pavements will need to be designed (using available design approaches) with a warmer-than-current design temperature and some “retrofitting” of surface materials may be necessary for existing perpetual pavements.

## 4.7 Conclusions

As a broad-brush generalization, climate is not expected to have a large effect on pavement performance. Studies by several authors (Dawson and Carrera 2010; Meagher et al. 2012; Qiao et al., in press) have shown that pavement response and

maintenance needs are insensitive to many changes in climatic loading or can be expected to be handled by routine maintenance intervention, albeit perhaps with slightly modified material properties so as to be ready for future climate changes. The implication of this is that standards need to be reviewed in the light of anticipated changes in climate, so that they no longer only rest on historic climate information. Such modifications will need to be regionally specific, but down-scaling uncertainties remain an issue in developing robust predictions on which to base those predictions, so some conservatism is likely.

Particular features of pavements (or of pavement design and materials formulation standards) that are expected to need some adaptation are:

1. design criteria regarding temperature and return period of storm flows,
2. drainage systems, particularly to make them self-cleaning and easily inspectible,
3. rut-resistance and stripping-resistance resurfacings on ‘perpetual pavements’,
4. modification of light pavements in high latitudes to resist more frequent winter thaws.

Overall, concentrating on these technical issues is unlikely to be a significant problem, nor a great economic challenge when compared to the necessary response from highway engineers to the wider social, economic, technical and political impacts on pavements and available pavement materials that can be guessed at over the same time-scales.

## References

- Austrroads (2004). Impact of Climate Change on Road Infrastructure, Report AP-R243.
- Bizjak, K. F. (2010). Soil wetting—drying study. Report 4, Pavement Performance of Remediation Requirements following Climate Change—P2R2C2. Retrieved from [http://www.eranetroad.org/index.php?option=com\\_docman&task=cat\\_view&gid=88&Itemid=53](http://www.eranetroad.org/index.php?option=com_docman&task=cat_view&gid=88&Itemid=53).
- Bobes-Jesus, V., Pascual-Muñoz, P., Castro-Fresno, D., & Rodriguez-Hernandez, J. (2013). Asphalt solar collectors: a literature review. *Applied Energy*, 102, 962–970.
- Brown, R. D., & Coté, P. (1992). Interannual variability of landfast ice thickness in the Canadian high Arctic, 1950–1989. *Arctic*, 45, 273–284.
- Carrera, A., & Dawson, A. R. (2010). Pavement response to rainfall changes, Report 9, Pavement Performance & Remediation Requirements following Climate Change project, Road ERA-Net, 50 pp. Retrieved from [http://www.eranetroad.org/index.php?option=com\\_docman&task=cat\\_view&gid=88&Itemid=53](http://www.eranetroad.org/index.php?option=com_docman&task=cat_view&gid=88&Itemid=53).
- Chan, I. (2001). *Soil salinity study*. Retrieved from [http://www.geocities.ws/wingian\\_chan/salinity/main.html](http://www.geocities.ws/wingian_chan/salinity/main.html).
- Dawson, A. R., & Carrera, A. (2010). Overall advice & summary, Report 11, Pavement Performance & Remediation Requirements following Climate Change project, Road ERA-Net, 23 pp. Retrieved from [http://www.eranetroad.org/index.php?option=com\\_docman&task=cat\\_view&gid=88&Itemid=53](http://www.eranetroad.org/index.php?option=com_docman&task=cat_view&gid=88&Itemid=53).
- Eigenbrod, K. D., & Kennepohl, G. J. A. (1996). Moisture accumulation and pore water pressures at base of pavements. *Transportation Research Record*, 1546, 151–161.
- Fermi National Accelerator Laboratory (1999). <http://www.esh.fnal.gov/Weather/SolarRadiation.htm>.

- Graves, R. C., & Mahboub, K. C. (2006). Pilot study in sampling-based sensitivity analysis of NCHRP design guide for flexible pavements. *Transportation Research Record*, 1947, 123–135.
- Hall, D. K., & Rao, S. (1999). Predicting subgrade moisture content for low-volume pavement design using in-situ moisture content data. *Transportation Research Record*, 1652, 98–107.
- Hall, K. T., & Correa, C. E. (2003). Effects of sub-surface drainage on performance of asphalt and concrete pavements, National Co-operative Highway Research Program, Report 499, Transportation Research Board.
- Hoff, A., & Lalagüe, A. (2010). Analysis of pavement structural performance, Report No. 7, Pavement Performance of Remediation Requirements following Climate Change—P2R2C2. Retrieved from [http://www.eranetroad.org/index.php?option=com\\_docman&task=cat\\_view&gid=88&Itemid=53](http://www.eranetroad.org/index.php?option=com_docman&task=cat_view&gid=88&Itemid=53).
- IPCC (1992). Policymaker summary of working group I (Scientific Assessment of Climate Change). In *First Assessment Report Overview and Policymaker Summaries and 1992 IPCC Supplement*, IPCC, June.
- IPCC (2007). Summary for policymakers. In S. Solomon, D. Qin, M. Manning, Z. Chen, M. Marquis, K. B. Averyt, M. Tignor & H. L. Miller (Eds.), *Climate Change 2007: The Physical Science Basis. Contribution of Working Group I to the Fourth Assessment Report of the Intergovernmental Panel on Climate Change*, Cambridge University Press, (pp. 18).
- Kameyama S., Kato M., Kawamura A., Himeno K., & Kasahara A. (2002). Effects of frost heave on the longitudinal profile of asphalt pavements in cold regions. 1–14. In *Ninth International Conference on Asphalt Pavements*, International Society for Asphalt Pavements, St. Paul, MN.
- Karl, T. R., Melillo, J. M., & Peterson, T. C. (Eds.). (2009). *Global climate change impacts in the United States*. Cambridge: Cambridge University Press.
- Kim, S., Ceylan, H., & Heitzman, M. (2005). Sensitivity study of design input parameters for two flexible pavement systems using the mechanistic-empirical pavement design guide. In: *Proceedings of the 2005 Mid-Continent Transportation Research Symposium*, Iowa, US.
- Kinsella, Y., & McGuire, F. (2005). Climate change uncertainty and the state highway network: a moving target, Transit New Zealand.
- Lebassi, B., Gonzalez, J., Fabris, D., Maurer, E., Miller, N., Milesi, C., et al. (2009). Observed 1970–2005 cooling of summer daytime temperatures in coastal California. *Journal of Climate*, 22, 3558–3573.
- Li, H. (2012). Evaluation of cool pavement strategies for heat Island mitigation, Institute of Transportation Studies, University of California, Davis, Research Report UCD-ITS-RR-12-33.
- Mallick, R. B., Chen, B-L., & Bhowmick, S. (2009). Reduction of urban heat Island effect through harvest of heat energy from asphalt pavements. In *Proceedings of 2nd International Conference Countermeasures to Urban Heat Islands*, Berkeley, California (pp. 20). Retrieved from <http://heatisland2009.lbl.gov/docs/211420-mallick-doc.pdf>.
- Mallick, R. B., Chen, B-L., & Bhowmick, S. (2012). Harvesting heat energy from asphalt pavements: Development of and comparison between numerical models and experiment. *International Journal of Sustainable Engineering*, 5(2), 159–169
- Mallick, R. B., Radzicki, M. J., Daniel, J. S., & Jacobs, J. M. (2014). Use of system dynamics to understand the long term impact of climate change on pavement performance and maintenance cost, *Transportation Research Record*, (submitted).
- Masad, S. A., & Little, D. N. (2004). *Sensitivity analysis of flexible pavement response and AASHTO 2002 design guide to properties of unbound layers*. Austin: International Center for Aggregates Research, the University of Texas at Austin.
- Meagher, W., Daniel, J. S., Jacobs, J. M., & Linder, E. (2012). A methodology to evaluate the implications of climate change on the design and performance of flexible pavements. *Transportation Research Record*, 2305, 111–120.
- Milani, F., Takallou, B. (2009). Oxidation and pyrolysis of asphalt its effects on the environment and asphalt performance. Retrieved from [http://www.apaca.org/magazine\\_article.shtml?action=view\\_single\\_mag\\_article&id=8&htitle=Asphalt%20Magazine&mag\\_id=4](http://www.apaca.org/magazine_article.shtml?action=view_single_mag_article&id=8&htitle=Asphalt%20Magazine&mag_id=4).

- NCAR (2008). MAGICC/SCENGEN software, version 5.3. User manual. Retrieved August 2013, from <http://www.cgd.ucar.edu/cas/wigley/magicc/UserMan5.3.v2.pdf>.
- Neelin, J. D., Langenbrunner, B., Meyerson, J. E., Hall, A., & Berg, N. (2013). California winter precipitation change under global warming in the coupled model intercomparison project phase 5 ensemble. *Journal of Climate*, 26, 6238–6256.
- NIWA et al. (2004). Climate Change Effects and Impacts Assessment: A Guide for Local Government in New Zealand, National Institute of Water and Atmospheric Research (Ministry for the Environment), MWH and Earthwise Consulting.
- Qiao, Y., Dawson A. R., Parry, T., & Flintsch, G. (2013b). Quantifying the effect of climate change on the deterioration of a flexible pavement, In *Proceedings of Bearing Capacity Roads & Railways Conference*, 2, June, (pp. 555–564).
- Qiao, Y., Dawson A. R., Parry, T., & Flintsch, G. (in press). Evaluating the effects of climate change on maintenance intervention strategies and Life-Cycle Costs, Submitted to Transportation Research Part D: Transport and Environment.
- Qiao, Y., Flintsch, G., Dawson, A. R., & Parry, T. (2013a) Examining the effects of climatic factors on flexible pavement performance and service life, *Jnl Transportation Research Board*, 2349, 101–107.
- Smith N. V., Saatchi, S. S., & Randerson, T. (2004). Trends in high latitude soil freeze and thaw cycles from 1988 to 2002. *Journal of Geophysics Research: Atmospheres*, 109(D12101).
- U.S. Department of Transportation. (2002). *Freight analysis framework*. Washington, DC: Federal Highway Administration.
- Van Deusen, D., Schrader, C., Bullock, D., Worel, B. (1998). Recent research on springtime thaw weakening and load restrictions in the state of Minnesota. *Journal of Transportation Research Board*, 1615, 21–28.
- Wikipedia (2013). *Climate change*, Retrieved from [http://en.wikipedia.org/wiki/Climate\\_change](http://en.wikipedia.org/wiki/Climate_change).
- Winkelman, T. J. (2004). Open-graded drainage layer performance in Illinois, Final Report, Physical Research Report No. 147, Illinois Department of Transportation, August.
- Wolters, R. O. (2003). Raveling of hot-mixed asphalt. Retrieved from [http://www.asphaltisbest.com/PDFs/Raveling\\_of\\_HMA\\_Oct03.pdf](http://www.asphaltisbest.com/PDFs/Raveling_of_HMA_Oct03.pdf).
- World Resources Institute (2005). Solar radiation and climate change. Retrieved from <http://www.wri.org/publication/content/7642>.
- Yamagata, H., Nasu, M., Yoshizawa, M., Miyamoto, A., & Minamiyama, M. (2008). Heat island mitigation using water retentive pavement sprinkled with reclaimed wastewater. *Water Science and Technology*, 57, 763–771.
- Zuo, G., Drumm, E. C., & Meier, R. W. (2007). Environmental effects on the predicted service life of flexible pavements. *Journal of Transportation Engineering*, 133(1), 47–56.

# Chapter 5

## Climate Change Scenarios and Their Potential Effects on Transportation Infrastructure Systems

Wynand JvdM Steyn

**Abstract** Various theories and understandings exist around climate change. Depending on the viewpoint taken, various scenarios can be generated for the potential effects of these scenarios on transport infrastructure systems. This chapter evaluates the process of developing such scenarios with the focus on transportation infrastructure systems, and the potential effects that the various scenarios has on the systems.

### 5.1 Introduction

Various theories and understandings exist regarding climate change and its potential effects on infrastructure. This chapter evaluates the basic definitions and concepts to enable a better understanding of the available literature and chapter contents in this book.

The focus of the chapter is on published information by international reputable bodies and associations, attempting to steer clear from controversial issues and statements around the level of climate change and the exact effects, as these issues are tackled in more detail in the remainder of this book. Therefore, it evaluates the concept and definitions of climate change, discuss how this relate to transportation infrastructure systems and evaluate the concept of scenario planning and how it link to climate change issues in transportation infrastructure systems.

The chapter starts with a discussion of the various concepts and definitions, and a global perspective on Green House Gasses (GHG) and related terminologies, followed by the general potential effects on transportation infrastructure systems. The concept and process of scenario planning is discussed and some examples of potential scenarios that may be of importance to transportation systems evaluated.

---

W.J. Steyn (✉)

Department of Civil Engineering, University of Pretoria, Pretoria, South Africa  
e-mail: wynand.steyn@up.ac.za

© Springer-Verlag Berlin Heidelberg 2014

K. Gopalakrishnan et al. (eds.), *Climate Change, Energy, Sustainability and Pavements*,  
Green Energy and Technology, DOI 10.1007/978-3-662-44719-2\_5

159



## 5.2 Concept and Definitions

It is essential to understand the concepts being discussed and agree on standard definitions for the terminology used to ensure that a fundamental discussion and opinion about a subject can be formed.

Various organizations and associations provide their own definitions of climate change. The World Road Association (PIARC) defines climate change as:

...a change in climate that is attributed directly or indirectly to human activity that alters the composition of the global atmosphere and that is in addition to natural climate variability over comparable time periods (PIARC 2012).

The Transportation Research Board (TRB) defines climate change as:

...a statistically significant variation in either the mean state of the climate or its variability over an extended period, typically decades or longer, that can be attributed to either natural causes or human activity. Weather refers to the familiar hour-by-hour, day-by-day changes in temperature, cloudiness, precipitation, and other atmospheric phenomena (TRB 2008).

Evaluation of these definitions indicates that most transportation related organizations agree that the changes in climate need human intervention, as opposed to accepted natural climate cycles.

FHWA (2012) defines climate change vulnerability as a function of the transportation system's exposure to climate effects, sensitivity to climate effects, and adaptive capacity, while Bredica (2002) defines it as: "... a susceptibility to incidents that can result in considerable reductions in road network serviceability. These incidents may be more or less predictable, caused voluntarily or involuntarily, by man or nature." Adaptation is defined as the "autonomous or policy-driven adjustments in practices, processes or structures to take account of changing climatic conditions" (PIARC 2012).

Obviously, the level of exposure will depend on the location of the transportation asset (coastal, inland, mountainous or flat area). The adaptive capacity of the infrastructure refers to the systems' ability to adjust in coping with climate variability and impacts.

## 5.3 Global Perspective on GHG and Related Technologies

Widespread agreement exists among international scientists and governments that the global climate is becoming warmer, these changes could cause severe and lasting impacts and that these changes are at least partly caused by human activity. Consensus exist that human activity contribution to climate change is mainly through release of GHGs that accumulate in the atmosphere and trap the earth's heat. Further, these activities reduce the ability of nature to absorb GHG emissions through forested lands to other uses (AASHTO 2008).

Numerous studies in recent years have attempted to measure the pace of global climate change and determine the role of human activities in causing that change. It has been concluded that temperatures are rising (with 11 of the 12 years from 1995 to 2006 ranking among the 12 warmest years for global surface temperature since 1850), sea levels are rising (global average sea level rise at an average rate of 1.8 mm per year since 1961) and that the arctic ice shelf is retreating (annual average extent of Arctic Sea ice has shrunk by 2.7 % per decade since 1978) (AASHTO 2008).

GHGs are atmospheric gasses (e.g. water vapor, CO<sub>2</sub>, CH<sub>4</sub>, N<sub>2</sub>O and O<sub>3</sub>) that absorb and emit radiation in the thermal infrared waveband, thereby playing a major role in global temperature balance. Although GHGs are naturally occurring, their concentrations in the atmosphere are greatly affected by human activity such as combustion of fossil fuels (GHG contributor) and deforestation (GHG sink).

Research is showing that GHG emissions are growing continuously despite increases in energy efficiency. This growth is attributed to global demographic, economic, and social changes, mainly driven by economic growth in developing countries. CO<sub>2</sub> emissions currently represent the majority of GHG emissions, and its growth rate is increasing. From a transportation infrastructure systems viewpoint this is a major concern, as the transportation sector contributes a large and increasing share of GHG emissions, with transportation related sources currently accounting for approximately 28 % of all GHG emissions in the US and growing (USDS 2010). Generally, GHG emissions are growing faster in developing countries than in developed countries, with total GHG emissions from developing countries projected to exceed those of developed countries by a substantial margin by 2030.

## 5.4 Relation to Transportation Infrastructure Systems

The focus of this book and chapter is on the specific effects of climate change on transportation systems, and thus it is important to keep the focus on those areas where these systems are specifically impacted on, and appreciate the level of such impacts. Obviously, impacts on the transportation system will have widespread secondary impacts on the economy and society, as these systems provide the logistic network for goods and passengers to travel between destinations and markets.

Literature indicates that the following five climate changes are viewed as being potentially important to transportation systems:

- Increases in very hot days and heat waves;
- Increases in Arctic temperatures;
- Rising sea levels;
- Increases in intense precipitation events, and
- Increases in hurricane intensity (AASHTO 2008).

From a transportation infrastructure viewpoint, increases in very hot days will compromise road pavement integrity (both asphalt and concrete pavements) and cause deformation of rail lines, while increases in Arctic temperatures will cause subsidence of permafrost, subsequently disrupting roads, rail lines and airports in the arctic regions. Rising sea levels specifically affect low lying coastal areas' vulnerability to flooding, while increased rainfall in general requires redesign and replacement of drainage structures, as well as changes in bearing capacity of granular pavement layers. More frequent and severe hurricanes cause potential disruption in transportation service in affected areas and tie up resources in evacuation and restoration efforts (AASHTO 2008).

One of the goals of climate change policy is to stabilize global average temperatures. As it is accepted that emission of Greenhouse Gasses (GHG) leads to increased temperatures, one major strategy involves slowing down, stabilizing and potentially decreasing the rate of GHG emissions and concentrations in the atmosphere. Various methods are being evaluated to achieve this goal, including carbon pricing or tax and cap and trade programs.

GHG emissions is of importance to the transportation system as it is estimated that approximately 33 % of GHG emissions in the United States originates from transportation (around 72 % of this originating from road use). This can be impacted through improved fuel economy, changes in fuel type, decreases in vehicle miles travelled and improved traffic operations and logistics (AASHTO 2009).

Transportation infrastructure is designed for typical weather patterns, reflecting local climate and incorporating assumptions about a reasonable range of temperatures and precipitation levels based on historical weather databases. The infrastructure will be affected most by those climate changes that cause environmental conditions to extend outside the range for which the system was designed (TRB 2008). Thus, one of the main effects is different operational conditions and thus responses to vehicular and environmental loads, as well as changes to current design inputs.

## **5.5 Scenario Planning and Its Link to Climate Change Issues in Transportation Infrastructure Systems**

In dealing with the effects and impacts of climate change issues on the transportation system, one of the tools that can be used is scenario planning. As the potential climate change events are not set, and various possibilities exist for different types of events to occur, with its respective probabilities, and also the effects of different types of adaptation and reaction to such events, it is important to use a method that can deal with the different types of outcomes.

Scenario planning is a method that allows for evaluation of future events and their impacts through understanding of the nature and impact of the most uncertain and important driving forces affecting the evaluated situation. The objective is to

develop a suite of diverging outcomes (scenarios), thereby increasing the knowledge of the environment and increasing the perception of possible future events. Thus, strategies can be developed for dealing with different outcomes, based partly on their respective probability of occurrence. Scenario planning is widely used as a strategic management tool, and can be adapted for use in situation like evaluation of climate change impacts on transportation systems (Börjesson 2007).

Scenario planning derives from the observation that, given the impossibility of knowing precisely how the future will play out, a good decision or strategy to adopt is one that plays out well across several possible futures. To find that strategy, scenarios are created in plural, such that each scenario diverges markedly from the others. These sets of scenarios are options of the future, each one modeling a distinct, plausible set of conditions. Thus, the purpose of scenario planning is to highlight large-scale forces that push the future in different directions to make these forces visible, thereby making better decisions. Scenario planning begins by identifying the focal issue or decision (Wilkinson 2009).

Scenario planning is a process that can help transportation professionals to prepare for what lies ahead. It provides a framework for developing a shared vision for the future by analyzing various forces that affect communities in terms of climatic change and its effects on transportation infrastructure systems. The technique was originally used by private industry to anticipate future business conditions and to better manage risk (FHWA 2011).

It thus creates guiding principles for future potential conditions. These principles become a basis for scenarios. Stakeholders compare scenarios, using either qualitative or quantitative methods. The ultimate outcome is a shared future vision that provides a framework for transportation priorities, goals, recommendations, and investments. Through comparing scenarios and discussing their possible outcomes, the technique helps participants to identify and challenge assumptions about the future, discuss tradeoffs, and make better decisions (FHWA 2011).

Scenarios help decision makers reconcile uncertainties and have the potential to improve awareness around issues that could become increasingly important to society through exploring plausible and predictable outcomes (Shell 2013).

Since scenarios are a way of understanding the dynamics shaping the future, it is important to identify the primary driving forces at work. These can be social dynamics, economic issues, political issues or technological issues. The point of listing the driving forces is to examine long-term forces that ordinarily work well outside current concerns. Once these forces are enumerated, some forces can be called predetermined (completely outside control). After identifying the predetermined elements, a number of uncertainties will be left. These are sorted to make sure they are critical uncertainties (key to the focal issue). The goals are twofold—better understanding of all uncertain forces and their relationships with each other and identifying those that are most important to the focal issue and most impossible to predict to float up to the surface (Wilkinson 2009).

Each scenario planning effort will differ depending on the issues addressed and the resources available. While scenario planning can be implemented in many ways, the key elements include:

- Use of scenarios to compare and contrast interactions between multiple factors, such as transportation, land use, and economic development;
- Analysis of how different land-use, demographic, or other types of scenarios could impact transportation networks;
- Identification of possible strategies that lead a state, community, region, or study area toward achieving elements of the preferred future, and
- Public engagement throughout the process (FHWA 2012).

## 5.6 Process for Scenario Planning

### 5.6.1 Introduction

Scenarios are narratives or sets of assumptions that explore plausible trajectories of change. They provide a means of visioning possible future changes and different policy and investment options. Stakeholders assess scenarios through qualitative comparison, brainstorming, use of visualization tools, application of travel demand models, and use of scenario analysis tools (FHWA 2012).

The TRB provides a decision framework for transportation professionals to use in addressing impacts of climate change on transportation infrastructure. It includes the following six steps:

- Assess how climate changes are likely to affect various regions of the country and modes of transportation;
- Inventory transportation infrastructure essential to maintaining network performance in light of climate change projections to determine whether, when, and where the impacts could be consequential;
- Analyze adaptation options to assess the trade-offs between making the infrastructure more robust and the costs involved. Consider monitoring as an option;
- Determine investment priorities, taking into consideration the criticality of infrastructure components as well as opportunities for multiple benefits (e.g., congestion relief, removal of evacuation route bottlenecks);
- Develop and implement a program of adaptation strategies for the near and long terms, and
- Periodically assess the effectiveness of adaptation strategies and repeat Steps 1–5 (TRB 2008).

As a good example of a scenario planning framework, the current proposed FHWA scenario planning framework is summarized. Although there are a host of frameworks available in literature, this version has been focused on transportation systems and as such is viewed /deemed as a good starting point for any organization interested in running such planning efforts.

### **5.6.2 FHWA Six-Phase Scenario Planning Framework**

#### Phase 1: Scope the effort and engage partners

Phase 1 focuses on initiating a scenario planning effort by identifying the major objectives of the process and the resources needed to support the effort. It engages partners and identifies ways to integrate scenario planning into existing agency policies and programs. The 3 steps for Phase 1 require agencies to identify:

- The objectives, anticipated goals and major components of the process;
- A scope and budget, and
- Roles and responsibilities for stakeholders involved.

The output of Phase 1 is a work plan to carry the scenario planning effort forward. This is a tool showing how the scenario planning effort will meet its stated goals and objectives within time and budget constraints. It should explicitly document the expected outcomes and objectives for the effort and define roles and expectations for leadership and involved stakeholders.

#### Phase 2: Establish a baseline analysis and identify factors and trends that affect the study area

Phase 2 focuses on collecting data to describe the study area. This includes information about the transportation system, demographics, environmental resources and constraints and land-use patterns related to the transportation system. The baseline data will be compiled into a baseline analysis to compare alternative scenario outcomes with current conditions and can also help agencies to tailor scenario analysis tools to reflect specific regional conditions. Phase 2 requires agencies to:

- Characterize the supply, suitability and demand for transportation and land use as it relates to the transportation system, and
- Consider how trends could impact these factors in the future.

Possible outputs of Phase 2 are analyses of baseline data that describe the supply, suitability, and demand of transportation and transportation-related land use in the region. The outputs could include an inventory of transportation systems, a land suitability analysis, or evaluations of historical population growth or land use.

#### Phase 3: Establish future goals and aspirations based on values of the study area

Phase 3 focuses on identifying values, goals, and aspirations with input from stakeholders. Values suggest priorities and help to clarify the study area's unique factors. Goals and aspirations focus on what stakeholders hope to change in the future. The values, goals and aspirations can also provide a framework for developing indicators to analyze scenario impacts. It represents a first step toward developing a comprehensive regional vision that depicts the region's long-term desired transportation and development patterns. Steps in Phase 3 require agencies to:

- Brainstorm and document key values and priorities for the study area, and
- Compile the preferences into a set of working principles for how the study area wants to move forward. These principles will provide a framework for developing scenarios.

Possible outputs of Phase 3 are working principles that document the broad values, goals, and aspirations expressed by study-area stakeholders. The principles provide a basic framework for scenario development, analysis, and the comprehensive vision.

#### Phase 4: Create baseline and alternative scenarios

Phase 4 focuses on developing multiple scenarios, including baseline and alternative scenarios, to assess how future changes could impact the transportation system as well as travel demands or needs. Scenarios combine the trends and variables identified in Phase 2 and values, goals, and aspirations identified in Phase 3 with appropriate policy and investment responses, creating plausible and distinct alternative pictures of how the community, region, or study area might look and function in the future. The scenarios provide a common framework for all parties to discuss the costs and benefits of transportation decisions while taking future uncertainties into consideration. The types of scenarios developed and the specific elements they include will vary depending on the focus and goals of the scenario planning process. Phase 4 requires agencies to:

- Identify needs for scenario development;
- Refine existing analysis tools;
- Prioritize trends and factors most important to transportation and land use in the region and assess interaction with goals, aspirations and values;
- Identify potential strategies or actions to address trends;
- Compile the trends and strategies identified into several scenarios. Each scenario offers a plausible alternative vision of how the future could evolve and how the study area could respond, and
- Communicate scenarios to stakeholders.

Phase 4 has several possible outputs, including identification of an appropriate scenario analysis tool. An additional possible outcome of Phase 4 is the development of several scenarios, including a scenario focused on baseline conditions and alternative scenarios that describe plausible, distinct futures for the study area.

#### Phase 5: Assess scenario impacts, influences, and effects

Phase 5 focuses on analyzing scenarios. Scenario analysis typically involves assessing the impacts, influences, and effects that various scenarios exert on selected indicators. Indicators are statistical values or groups of values that are used to compare two or more scenarios. Phase 5 requires agencies to:

- Develop or identify indicators to compare scenarios;
- Use indicators to identify scenario impacts, and
- Obtain feedback on analysis and refine scenarios as needed.

Phase 5 has several possible outputs, including a list of indicators to compare scenario outcomes and a qualitative or quantitative assessment of scenario impacts.

Phase 6: Craft the comprehensive vision and identify strategic actions and performance measures.

Phase 6 focuses on consolidating scenario impacts, as well as community preferences and priorities established in previous phases, into a comprehensive vision. The vision is grounded in realistic analysis and incorporates possible future changes. The vision provides a framework for building consensus on policies and strategies related to transportation, growth, land use, or other issues. An action plan is developed that details strategies for achieving the comprehensive vision. Potential strategies could include updates to proposed locations for new growth, policies and programs relevant to transportation, land use, economic development, environmental preservation, or design and specification changes. The action plan describes responsibilities for implementation and monitoring to guide progress toward the vision. Phase 6 requires agencies to:

- Craft a comprehensive vision;
- Validate and refine the vision, and
- Develop an action plan to implement the vision and continue monitoring outcomes over time.

Possible outputs for Phase 6 are a comprehensive vision that documents the preferences and desired future of the study area as well as an action plan, indicating implementation of the vision and guiding preferred actions and investments at all levels (FHWA 2011).

## **5.7 Example Scenarios and Impacts**

### ***5.7.1 Introduction***

In Sects. 5.5 and 5.6 the background and framework for scenario planning has been presented and discussed. In this section some potential examples of scenarios that may impact on transportation infrastructure systems are highlighted and briefly discussed. The idea is not to provide thorough scenario planning for these scenarios, but to state these as ideas that may be of importance to specific locations and systems. While some of the stated scenarios may be of immediate concern, some are provided as medium- to long-term scenarios. Further, examples from recent extreme event analyses are shortly discussed.



### ***5.7.2 Material Shortages***

Material shortages as a potential scenario is driven by sustainability, energy and climate change causes. Issues around sustainability are starting to put pressure on the provision of granular road construction materials and cementitious products in many countries, energy provision and the production of bituminous products from crude oils sources affects bitumen availability as climate changes cause potential problems in terms of the availability of potable water for road construction.

Sustainability issues focus on the prevention of wastage as well as the protection of natural resources. In many countries extraction of raw materials and gravels from new borrow pits are becoming a major challenge, causing dependence on virgin granular materials for road construction to be severely hampered. This leads to more reuse of reclaimed and existing materials, which may impact on the available design options, as these materials invariably have been stabilized before or already molded under heavy construction equipment and traffic over many years, which impact its properties.

GHG emissions from cement plants and power plants are putting strain on the provision of cement, fly-ash and other pozzolanic products from these sources. Attempts are made to clean up the production processes, which often leads to reduced availability of the traditional waste products, or move of these plants to remote areas with a resultant cost increase for these products. This puts a further strain on the costs of the provision and maintenance and rehabilitation of transportation infrastructure.

Focus on energy needs and the optimization of extraction of fuel and energy products from crude oil sources leads to strain on the supply of bituminous products worldwide. As bitumen is often viewed as a by-product of the provision of fuels, its supply is often minimized in more modern refineries. Further, the cost of crude oil, driven in part by demand and supply but also by political stability in many regions directly affect the cost of the bituminous products and the cost of transportation infrastructure. Moves away from carbon-based fuels to electric transportation can put further stress on the production of bitumen if the demands for these fuels decrease.

Climate change takes many forms, but one of these is lower rainfall and thus availability of potable water sources. In areas where drier and hotter climates are expected, the availability of potable water for road construction may hamper the construction process, as potable water is a major ingredient for road construction (typically between 150,000 and 200,000 l of water is required to construct a kilometer of conventional pavement (Paige-Green 2009)).

### ***5.7.3 Climate Change***

Climate change is obviously one of the major scenarios that need attention when evaluating the future of transport infrastructure systems. Some of these have already been discussed in brief in Sects. 1.3 and 1.4. Essentially, the focus falls on both

increases and decreases in temperatures as well as increases and decreases in rainfall.

Temperature changes affect mostly the surfacing and base layers of pavements with bituminous layers changing behavior between brittle and moldable conditions, while concrete experiences temperature gradients that causes warping and subsequent cracking. It is not only the long-term changes in climate that affect the performance of these materials, with the occurrence of extreme weather events that can run havoc on the behavior of the materials. Incidences of severe rutting of asphalt pavements on extremely hot days, and temperature related expansions and subsequent failure of concrete layers have been reported. In these cases the occurrence of the extreme events is more dangerous to the life of the transport infrastructure than longer term climate changes which can often be catered for through changes in the design inputs. The effect of extreme weather events is also quite costly, as the probability of occurrence is typically relatively low, although the effect caused by the event may be severe.

#### ***5.7.4 Traffic Change***

Changes in traffic patterns and properties are a potential scenario that is not often linked to climate change, energy and sustainability issues. However, there are conditions under which each of these issues may give rise to drastic changes in traffic demand, with resultant congestion or wastage in the provided facilities.

One of the often-stated results of climate change is rises in sea level in coastal areas. Some of the impacts of this on traffic demand are potential breaks in road and rail links through inundation of such links. These breaks affect the remainder of the network also, as traffic volumes and delays potentially increases, compromising network capacity.

Energy demands has already been shown to potentially change the availability and costs of fuels for current vehicles, as well as the demand for electric vehicles that are growing. This may affect the way in which commuters use their vehicles, through minimizing and optimizing trips and moves to public transportation options (where available). Changes in work habits due to the cost of transportation may also affect the demand for transportation infrastructure.

Sustainability issues are driving processes, mainly in metropolitan areas, where more emphasis is put on public transportation systems. Increased use of public transportation systems leads to demand for higher capacity and thus changes in the ratio of public transport facilities versus private transport facilities. Changes in demand also affect the type of facilities to be provided, with resultant changes in the vehicular loading on the available infrastructure (moving from a high number of light cars to a smaller number of heavy buses will affect the deterioration of the available road structures).

### ***5.7.5 Recent Extreme Events Analyses***

As investigations of climate change and extreme weather event effects on transportation infrastructure systems are becoming more prevalent, the literature on the topic is growing and the understanding on the way that it affects different communities are becoming clearer. Due to differences in geography, environment, population, travel patterns, infrastructure design and local materials, the effects differ. Further, the detail incorporated into an analysis process, and the focus of the analysis affects the complexity of the process, input requirements and applicability of the outcome. Two examples of some recent investigations are summarized in this section:

- Complex detailed scenario planning example—Vulnerability of Virginia transportation infrastructure, and
- Simplified pavement focused example—Potential effects of climate change on South African roads.

#### **5.7.5.1 Vulnerability of Virginia Transportation Infrastructure (Lambert and Haowen 2013)**

The first example evaluates a recent multi-disciplinary evaluation of a range of potential scenarios. A study was conducted in the Hampton Roads area in Virginia, USA, to evaluate the potential impacts of climate change on transportation infrastructure using a FHWA decision model. The area is quite vulnerable due to potential sea level rise impacts, and its large population and significant transportation infrastructure. In this case the focus was on climate change events that affect the water table and possible flooding effects (thus water related issues). Various studies have been conducted in the area before, and through this process the area was already identified as vulnerable to climatic change events.

The analysis attempted to also incorporate wider issues such as economic, regulatory, innovation and maintenance issues and their interdependence into the analysis, as the climate change effects typically do not happen in isolation. Further, various levels of transportation infrastructure system, including existing and planned new infrastructure and transportation zones were incorporated in the analysis. The analysis then attempted to evaluate the effect of the anticipated climate impact scenarios on prioritization of maintenance and new construction projects as affected by the different scenarios. Issues such as the sensitivity of the various projects to climate changes were evaluated, and it became clear that a multitude of factors affect the vulnerability of the various projects, and that the use of a scenario planning decision making method is essential to ensure that all relevant impacts and outcomes are incorporated into the evaluation process. The importance of access to

reliable scientific groundwork to ensure factually based input data has been demonstrated, and also the multi-disciplinary nature of the process, where economic conditions and the expected changes in socio-economic behavior of the population can change the outcome of scenarios (Lambert and Haowen 2013).

### 5.7.5.2 Potential Effects of Climate Change on Roads

The second example indicates a similar process where the environment is much different, the study area is extended and the focus is on very specific pavement life related issues. In a recent unpublished academic study (Steyn and Pretorius 2014) the potential effects of climate change on roads in South Africa was evaluated through evaluation of the response of selected flexible pavements to projected climate change for the period of 40 years. Six locations (in different climatic regions) were analysed for changes in monthly rainfall, minimum and maximum temperatures. Current climatic data were compared with data for the projected 40 year period.

The effect of the temperature and moisture changes on the elastic stiffness of the asphalt concrete surfacing and granular pavement layers, and the resultant effect on the expected lives of the pavement structures were evaluated. Although clear trends in the expected temperature and precipitation rates were observed, for the specific pavement structures and traffic loads, these climate changes did not result in significant changes in the expected lives of the pavement structures. This is in stark contrast to similar studies in parts of the northern hemisphere where significant decreases are expected in pavement lives due to increases in arctic temperatures (and subsequent ground thaw effects) (PIARC 2012). The importance of local climate conditions, material properties and traffic composition is thus essential in order to make valid predictions regarding the vulnerability of transportation infrastructure systems to climate change.

## 5.8 Conclusions/Summary

This section focused on scenarios for climate change and their potential effects on transportation infrastructure systems. Numerous resources exist on these topics, and the objective is to highlight the available literature and procedures and emphasize the options available to transportation officials in dealing with climate change. The importance of a clear understanding of the causes of climate change and the different ways in which it affects transportation infrastructure systems (depending on their location and properties) is demonstrated. The use of scenario planning as a tool for the evaluation of the potential range of effects of climate change is demonstrated.

## References

- AASHTO. (2008). *Primer on transportation and climate change*. Washington, DC: American Association of State Highway and Transportation Officials (AASHTO). PCRT-1. ISBN:978-1-56051-417-6.
- AASHTO. (2009). *Strategies for reducing the impacts of surface transportation on global climate change: A synthesis of policy research and state and local mitigation strategies*. Washington, DC: American Association of State Highway and Transportation Officials (AASHTO). NCHRP Project 20-24(59), National Cooperative Highway Research Program, Transportation Research Board.
- Börjesson, M. (2007). Scenario planning resources. Retrieved July 19, 2013 from [http://www.well.com/~mb/scenario\\_planning/](http://www.well.com/~mb/scenario_planning/)
- Bredica, K. (2002). An introduction to road vulnerability: What has been done, is done and should be done. *Transport Policy*, 9(2), 117–127.
- FHWA. (2011). *FHWA scenario planning guidebook*. Washington, DC: Office of Planning, Federal Highway Administration, US Department of Transportation.
- FHWA. (2012). *Climate change & extreme weather vulnerability assessment framework*. FHWA-HEP-13-005. Washington, DC.: Federal Highway Administration, US Department of Transportation.
- Lambert, J. H., & Haowen, Y. (2013). *Assessing vulnerability and risk of climate change effects on transportation infrastructure*. University of Virginia. Retrieved August 13, 2013, from [http://www.virginia.edu/crmes/fhwa\\_climate/files/finalReport.pdf](http://www.virginia.edu/crmes/fhwa_climate/files/finalReport.pdf)
- Paige-Green, P. 2009. *The use of natural resources for sustainable roads. The sustainable transport and mobility handbook* (Vol. 1). Cape Town: Alive2green.
- PIARC. (2012). *Dealing with the effects of climate change on road pavements*. 2012R06EN. Paris: World Road Association (PIARC).
- Shell. (2013). What are scenarios? Retrieved July 22, 2013, from <http://www.shell.com/global/future-energy/scenarios/what-are-scenarios.html>
- Steyn, W. J. vdM., & Pretorius, T. (2014). The potential effects of climate change on selected flexible South African pavements. In 3rd International Conference on Transportation Infrastructure (ICTI 2014). Pisa, Italy. ISBN:978-1-138-00147-3.
- TRB. (2008). Potential impacts of climate change on U.S. transportation. *TRB Special Report 290*. Washington, DC: Transportation Research Board. ISBN 978-0-309-11306-9.
- USDS (United States Department of State). (2010). *U.S. climate action report 2010*. Washington, DC: Global Publishing Services.
- Wilkinson, L. (2009). How to build scenarios. Retrieved July 22, 2013, from <http://www.wired.com/wired/scenarios/build.html>

# Chapter 6

## Effect of Pavement Surface Conditions on Sustainable Transport

Karim Chatti and Imen Zaabar

**Abstract** This chapter deals with the effect of pavement surface conditions on transport costs, including Vehicle Operating Costs (VOC) and damage to transported goods. The chapter starts with a brief introduction on the need for economic analysis of pavement projects in the context of sustainable pavement management strategies. Then, various user costs are presented, focusing on those cost components that are specifically affected by pavement surface conditions. These include fuel consumption, repair and maintenance, and tire wear (vehicle operating costs), and damage to transported goods/packaging costs (non-vehicle operating costs). The discussion differentiates between empirical and mechanistic models putting a vision for future mechanistic-based models. Finally, a section on trends in emerging vehicle and tire technology and how they affect future costs is presented. The discussion does not include details on the effect of pavement conditions on changes in travel time, safety-related or other implications of pavement conditions.

### 6.1 Background

Understanding the costs of highway construction, highway maintenance, and vehicle operation is essential to sound planning and management of highway investments, especially under increasing infrastructure demands and limited budgetary resources. While the infrastructure costs borne by road agencies are substantial, the cost borne by the road users are even greater. Therefore, Vehicle Operating Costs (VOC) should be considered by highway agencies when evaluating pavement investment strategies. For conventional vehicles, these costs are related to fuel and oil consumption, tire wear, repair and maintenance, and depreciation. However, emerging vehicle technologies may involve other cost items. These costs depend on the vehicle class and are influenced by vehicle

---

K. Chatti (✉) · I. Zaabar  
Department of Civil and Environmental Engineering, Michigan State University,  
East Lansing, USA  
e-mail: chatti@egr.msu.edu

technology, pavement-surface type, pavement condition, roadway geometrics, environment, speed of operation, and other factors.

Road user costs represent a portion of the transportation cost. These costs include VOC, travel time delay, safety, comfort and convenience, and environmental impacts. Figure 6.1 presents the different components of road user costs (Bennett and Greenwood 2003).

VOCs are the costs associated with owning, operating, and maintaining a vehicle, which include fuel consumption, oil and lubrication, tire wear, repair and maintenance, depreciation, and license and insurance. VOC components modeled include fuel and oil consumption, repair and maintenance costs, tire wear and vehicle depreciation. Each of these cost components are typically modeled separately and summed to obtain overall vehicle operating costs. Common to many of these relationships is a road roughness factor used to describe the condition of the road. One such roughness measure is the International Roughness Index (IRI) developed as part of the World Bank Highway Development and Management (HDM) standards studies (Sayers et al. 1986).

Road roughness is a broad term describing the range of irregularities from surface texture through road unevenness. To better characterize the influence of road roughness on VOCs, the total texture spectrum was subdivided into the four categories defined in Fig. 6.2 (Sandberg and Ejsmont 2002).

This categorization of roughness allows a better evaluation of the surface factors influencing fuel consumption. As with fuel consumption, road roughness influences repair and maintenance costs, tire replacement, and the market value of vehicles.

Barnes and Langworthy (2004) estimated VOCs using data from various sources. Figure 6.3 shows the costs of fuel, tire replacement and repair and maintenance expressed as a percentage of total operating expenses. Figure 6.3 shows that fuel cost is the primary cost component followed by maintenance and repair costs, and tire wear. Therefore, the focus of this chapter is only on estimating these costs. The models are either empirical or mechanistic-empirical models. This section briefly reviews some of the major VOC models that have been developed.

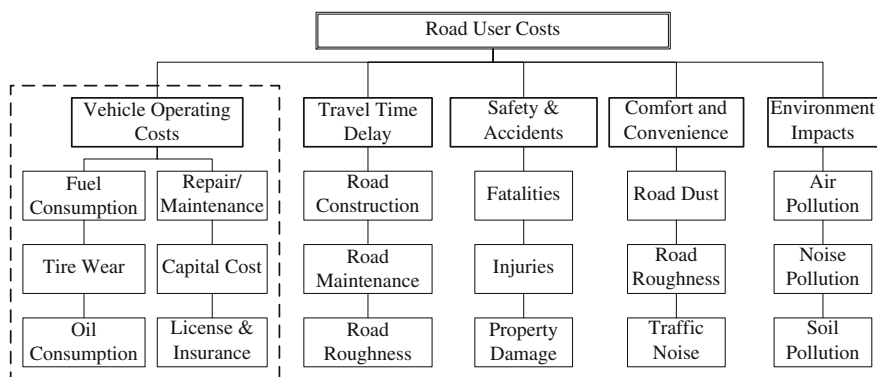
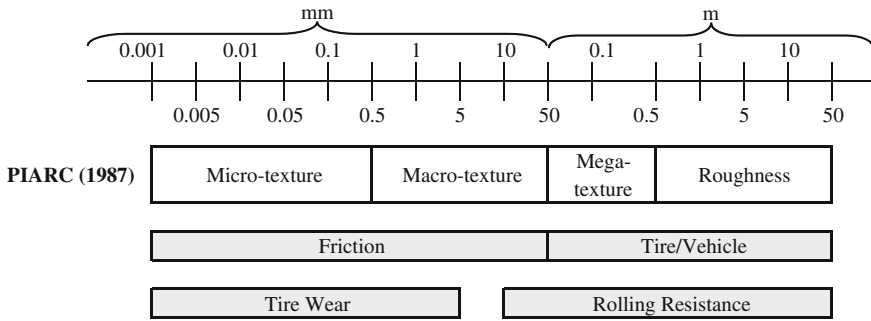

Fig. 6.1 Components of Road User Costs. Source adapted from Bennett and Greenwood (2003)



1 mm = 0.04 in, 1 m = 3.3 ft.

**Fig. 6.2** Ranges in terms of texture wavelength and their influence on pavement-tire interactions. *PIARC* permanent international association of road congresses. *Source* adapted from Henry (2000) and Sandberg and Ejsmont (2002)

**Fig. 6.3** Relative VOC costs for trucks. *Source* after Barnes and Langworthy (2004)

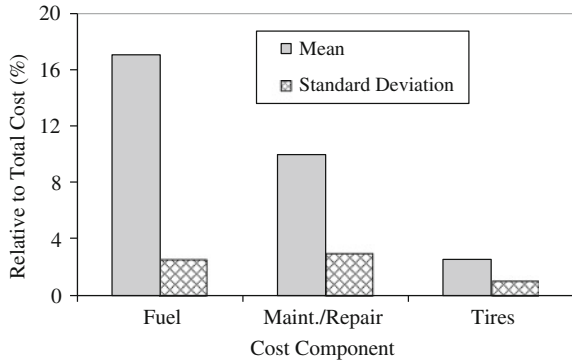

## 6.2 Vehicle Operating Costs Models

Based on the literature review, the major models that have been developed in various countries were identified. The most relevant models include:

- The World Bank’s HDM 3 and 4 VOC module (Bennett and Greenwood 2003);
- Texas Research and Development Foundation (TRDF) VOC model (Zaniewski et al. 1982);
- MicroBENCOST VOC module (McFarland et al. 1993);
- Saskatchewan VOC models (Berthelot et al. 1996);
- British COBA VOC module (British Department of Transportation 1993);
- Swedish VETO model (Hammarström and Karlsson 1991);
- Australian NIMPAC VOC module (National Association of Australian State Road Authorities 1978);
- ARFCOM model of fuel consumption (Biggs 1988);



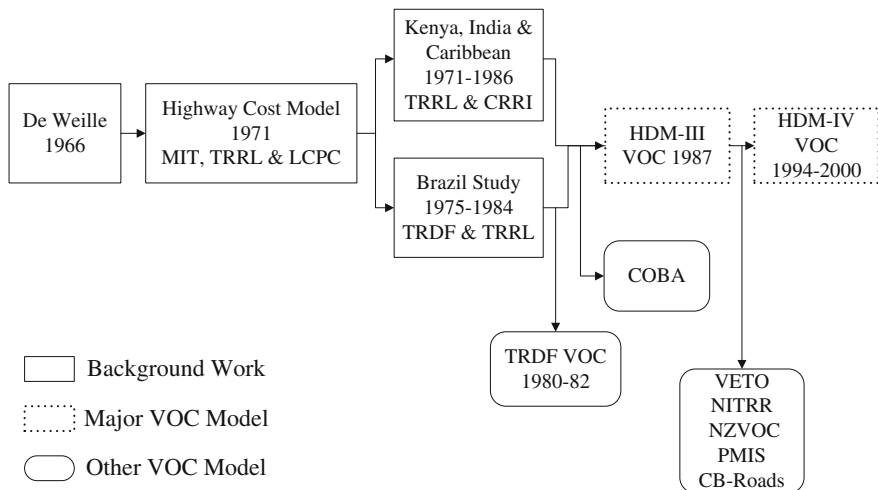

Fig. 6.4 World Bank VOC models development. Source Bein (1993)

- New Zealand NZVOC (Bennett 1989); and
- South African VOC models (du Plessis 1989).

Most of the present VOC models have benefited from the World Bank’s HDM research to some extent. Figures 6.4 and 6.5 outline the chronological development of these models. As shown in Fig. 6.4, the basis of HDM research dates back to a study by Weille (1966) for the World Bank, which lead to the development of the Highway Cost Model (Becker 1972) and subsequently to the most recent HDM 4 module.

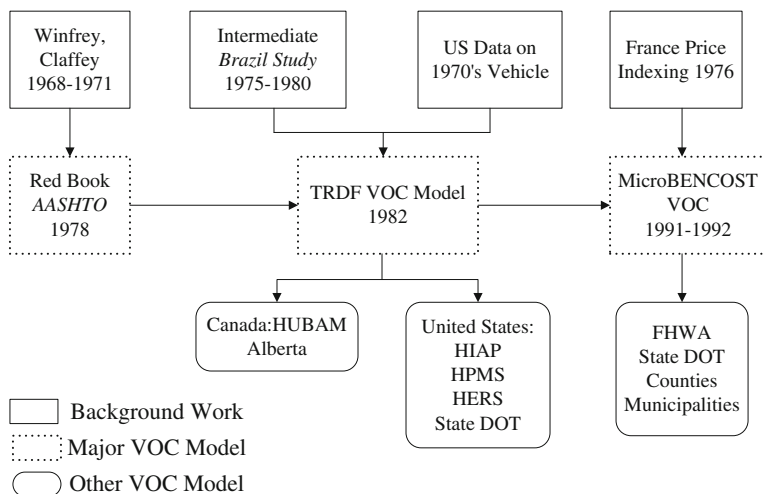

Fig. 6.5 VOC models development in the United States Source Bein (1993)

Figure 6.5 highlights the VOC research conducted in the United States, which was primarily initiated by Winfrey (1969) followed by Claffey (1971). These initial efforts laid the foundation for an assembly of VOC data and estimation models in the American Association of State Highway and Transportation Officials (AASHTO) Red Book by 1977. In 1982, Zaniewski et al. (1982) developed new VOC models as part of the Texas Research and Development Foundation (TRDF) study.

The TRDF models considered vehicle technology at that time and the effect of pavement roughness on VOC addressed in the Brazil HDM study (Chesher and Harrison 1987). These models were incorporated into the MicroBENCOST model which was intended to replace the AASHTO Red Book models. It should be noted that IRI was not an accepted roughness index at that time.

More recently, a user-friendly model for personal computers, “Vehicle/Highway Performance Predictor” (HPP), was developed for highway designers, planners, and strategists to estimate fuel consumption and exhaust emissions related to modes of vehicle operations on highways of various configurations and traffic controls (Klaubert 2001). This model simulates operations of vehicles by evaluating the vehicle external loads or propulsive demands determined by longitudinal and lateral accelerations, positive and negative road grades, rolling resistance, and aerodynamic drag for various transmission gears.

Table 6.1 summarizes the essential features of the existing VOC models. In summary, the majority of recent VOC models were developed in countries other than the USA. Many of these models are derived from previous models as a means for improving them. The most recent VOC model found in the literature is HDM 4 (Bennett and Greenwood 2003).

### **6.2.1 Fuel Consumption**

The models can be grouped into empirical- and mechanistic-based models. The only available USA models are those of the TRDF developed by Zaniewski et al.; an updated version of this model is in the MicroBENCOST VOC module (McFarland et al. 1993). The most recent models have been developed outside the U.S., and are mechanistic-empirical in nature. The relevant models are:

- The World Bank’s HDM 3 and 4 VOC models;
- Australian NIMPAC VOC models (adopted in HDM 3 with some modifications) and ARFCOM model of fuel consumption (adopted in HDM 4 with some modifications);
- Saskatchewan VOC models;

**Table 6.1** Categories of VOC Models (Empirical versus Mechanistic)

Feature	VOC models						
	HDM 3	COBA9	VETO	NIMPAC	ARFCOM	TRDF, MicroBENCOST	HDM 4
Empirical	✓	✓	–	✓	–	✓	–
Mechanistic	✓	–	✓	–	✓	–	✓
<i>Level of aggregation</i>							
Simulation	–	–	✓	–	✓	–	✓
Project level	✓	✓	✓	✓	✓	✓	✓
Network level	✓	✓	–	✓	✓	–	✓
<i>Vehicle operation</i>							
Uniform speed	✓	✓	✓	✓	✓	✓	✓
Curves	✓	–	✓	✓	✓	✓	✓
Speed change	–	–	✓	✓	✓	✓	✓
Idling	–	–	✓	✓	✓	✓	✓
Typical vehicles							
Default	✓	✓	✓	✓	✓	✓	✓
User specified	✓	–	✓	–	✓	–	✓
Modern truck	✓	–	✓	✓	✓	–	✓
<i>Road-related variables</i>							
Gradient	✓	✓	✓	✓	✓	✓	✓
Curvature	✓	✓	✓	✓	✓	✓	✓
Super-elevation	✓	–	✓	–	✓	–	✓
Roughness	✓	–	✓	✓	✓	✓	✓
Pavement type	✓	–	✓	✓	✓	–	✓
Texture	–	–	✓	–	✓	–	✓
Snow, water	–	–	✓	–	✓	–	✓
Wind, temperature	–	–	✓	–	✓	–	✓
Absolute elevation	✓	–	✓	–	✓	–	✓
<i>VOC components</i>							
Fuel, oil, tires, repair/maintenance, depreciation	✓	✓	✓	✓	✓	✓	✓
Interest	✓	–	✓	✓	–	–	✓
Cargo damage	–	–	✓	–	–	–	–
Overhead	✓	✓	✓	–	–	–	–
Fleet stock	–	✓	✓	–	–	–	–
Exhaust emissions	–	–	✓	–	–	–	✓

### 6.2.1.1 Empirical Models

Early work conducted in the USA established charts and tables for calculating fuel consumption cost based on vehicle class only (Winfrey 1969). Later Zaniewski et al. (1982) updated the fuel consumption tables based on empirical models derived from experimental field trials. Although this is the most comprehensive study conducted in the US to date, it did not treat all aspects of the problem. While fuel consumption tests were carried out for idling, acceleration, deceleration, and constant speed driving, the effect of pavement conditions on VOCs was only considered in the constant speed case. Constant speed mode was used for most of the experimental effort in these field trials, which also tested the effect of speed, grade, surface type, and pavement condition. No tests were carried out for larger truck combinations, and relations were assumed for a 3-S2 unit. Also the fuel consumption values were based on only one test vehicle in each class, except for the medium size car, where two identical vehicles were used so that the variance between the two identical cars could be used in the statistical analysis. However, the tests on the effect of pavement conditions showed no significant difference between the two identical cars, which means it was not necessary to do these tests after all (Zaniewski et al. 1982). According to Zaniewski's tables and charts, pavement conditions had a minor effect on fuel consumption. They found that grade, curvature, and speed were the major factors that affect fuel consumption.

The US Department of Transportation (USDOT) recently conducted a study to investigate highway effects on vehicle performance (Klaubert 2001). The study developed the following fuel consumption model based on regression analysis:

$$FC = \frac{1}{FE} \quad (6.1)$$

$$FE = a \left( \frac{T}{2} + b \right)^c \quad (6.2)$$

where:

- FC Fuel consumption in L/km
- FE Fuel economy (km/L)
- T Engine torque (N-m)
- a, b, c Regression coefficients, depending on gear number

### 6.2.1.2 Mechanistic Models

Mechanistic models predict that the fuel consumption of a vehicle is proportional to the forces acting on the vehicle. Thus, by quantifying the magnitude of the forces opposing motion one can establish the fuel consumption. Mechanistic models are an improvement over empirical models since they can allow for changes in the

vehicle characteristics and are inherently more flexible when trying to apply the models to different conditions. Some of the most recent mechanistic fuel consumption models are given below. The research team noted that most of the models are derived from earlier ones. The following models are discussed chronologically.

The South African fuel consumption model considers the total energy requirements governed by power and efficiency of the total engine (Bester 1981). Equation (6.3) shows the form of this model.

$$FC = 1000\beta \frac{P_{tot}}{v} \quad (6.3)$$

where:

- $FC$  Fuel consumption in mL/km
- $B$  Fuel efficiency factor in ml/kW/s or mL/KJ
- $P_{tot}$  Total power requirement in kW
- $V$  Vehicle velocity in m/s

The South African model assumes that the fuel efficiency of the vehicle is independent from the driving mode. However, a number of studies that were conducted in the early 1980s in Australia to model fuel consumption found that the fuel efficiency increases in the acceleration case (Biggs 1987). An improved mechanistic model was then developed to predict fuel consumption using the following relationship.

$$IFC = \alpha + \beta P_{tr} + \frac{\beta_2 M a^2 v}{1000} \quad (6.4)$$

where:

- $IFC$  Instantaneous fuel consumption in mL/s
- $\alpha$  Steady state fuel consumption in mL/s
- $\beta$  Steady state fuel efficiency parameter in mL/(KJm/s)
- $P_{tr}$  Tractive power in KW
- $\beta_2$  Acceleration fuel efficiency parameter in mL/(KJm/s<sup>2</sup>)
- $M$  Vehicle mass in kg
- $a$  Acceleration in m/s<sup>2</sup>
- $v$  Vehicle velocity in m/s

Some studies in the later 1980s in Australia found that the fuel efficiency is not only a function of tractive power but also a function of the engine power. The following mechanistic model (ARRB ARFCOM model) was developed to predict the fuel consumption as a function of the input (engine) and output power. The general form of the model is described by the following equations (Biggs 1988):

$$IFC = \max(\alpha, \beta * (P_{out} - P_{eng})) \quad (6.5)$$

$$\beta = \beta_b(1 + ehp * P_{out}/P_{max}) \quad (6.6)$$

where:

$P_{out}$  The total output power of the engine required to provide tractive force and run the accessories (KW)

$IFC$  Instantaneous fuel consumption in mL/s

$\alpha$  Steady state fuel consumption in mL/s

$\beta$  Steady state fuel efficiency parameter in mL/(KJm/s)

$P_{out}$  The total output power of the engine required to provide tractive force and run the accessories (KW)

$P_{eng}$  The total power of the engine required to run the engine and accessories (KW)

$\beta_b$  Base fuel efficiency parameter in mL/(KJm/s)

$ehp$  Proportionate decrease in efficiency at high output power

$P_{max}$  The rated power or the maximum power (KW)

The model predicts the engine and accessories power as a function of the engine speed. These relationships are from a regression analysis and are given below as Eqs. (6.7) and (6.8).

$$Pacs = EALC * \frac{RPM}{TRPM} + ECFLC * P_{max} \left( \frac{RPM}{TRPM} \right)^{2.5} \quad (6.7)$$

$$Peng = ceng + beng * \left( \frac{RPM}{1000} \right)^2 \quad (6.8)$$

where:

$Pacs$  The accessory power (KW)

$Peng$  The engine power (KW)

$EALC$  The accessory load constant (KW)

$ECFLC$  The cooling fan constant

$P_{max}$  The rated power or the maximum power (KW)

$RPM$  Engine speed

$TRPM$  Load governed maximum engine speed

$ceng$  Speed independent engine drag parameter

$beng$  Speed dependent engine drag parameter

However, Biggs (1988) noted that the determination of the parameter values for the engine drag equation was quite problematic with low coefficients of determination and high standard errors. Also, Biggs estimates the engine speed as a function of the vehicle speed in order to compute the engine power. There are two different equations in the engine speed model: One for a vehicle in top gear and the

other for a vehicle in less than top gear. However, these equations lead to a discontinuous relationship between vehicle speed and engine speed when the vehicle shifts into top gear. Such discontinuities lead to inconsistent fuel consumption predictions and should therefore be avoided (Biggs 1988).

Later, the World Bank updated the mechanistic fuel consumption model in the HDM-4 module (Bennett and Greenwood 2003). The model adopted is based on the ARRB ARFCOM mechanistic model (Australian model) described above, but with a change to the prediction of engine speed, accessories power, and engine drag. The general form of the model is expressed conceptually by Eq. (6.9).

$$IFC = f(P_{tr}, P_{accs} + P_{eng}) = \max(\alpha, \xi_b * P_{tot} * (1 + dFuel)) \quad (6.9)$$

where:

$IFC$	Instantaneous Fuel consumption in mL/s
$P_{tr}$	Power required to overcome traction forces (kW)
$P_{accs}$	Power required for engine accessories (kW)
$P_{eng}$	Power required to overcome internal engine friction (kW)
$\alpha$	Fuel consumption at Idling (mL/s)
$\xi$	Engine efficiency (mL/KW/s)

$$\xi_b \left( 1 + ehp \frac{(P_{tot} - P_{eng})}{P_{max}} \right)$$

$\xi_b$	Engine efficiency depends on the technology type (gasoline vs. diesel)
$P_{max}$	Rated engine power
$P_{tot}$	The total power required to provide tractive force and run the engine and accessories (KW)
$ehp$	engine horsepower (dimensionless)
$dFuel$	Excess fuel conception due to congestion

The engine efficiency decreases at high levels of output power, resulting in an increase in the fuel efficiency factor  $\xi$ . The total power required is divided into tractive power, engine drag, and vehicle accessories, respectively. The total requirement can be calculated by two alternative methods depending on whether the tractive power is positive or negative as shown in Table 6.2. The tractive power is a function of the aerodynamic, gradient, curvature, rolling resistance and inertial forces. The aerodynamic forces are expressed as a function of the air density and the aerodynamic vehicle characteristics and are given in Table 6.3. The gradient forces are a function of vehicle mass, gradient, and gravity. The curvature forces are computed using the slip energy method. The rolling resistance forces are a function of vehicle characteristics, pavement conditions, and climate. The inertial forces are a function of the vehicle mass, speed, and acceleration (Table 6.3).

Recently, Chatti and Zaabar (2012) calibrated the HDM 4 model to the U.S. conditions. The analysis showed that the HDM 4 fuel consumption model, after

**Table 6.2** Current HDM 4 fuel consumption model (2003)

Name	Description	Unit
Total power ( $P_{tot}$ )	$P_{tot} = \frac{P_{tr}}{edt} + P_{accs} + P_{eng} \text{ for } P_{tr} \geq 0, \text{ uphill/level}$ $P_{tot} = edtP_{tr} + P_{accs} + P_{eng} \text{ for } P_{tr} < 0, \text{ downhill}$	kW
edt	Drive-train efficiency factor	–
Engine and accessories power ( $P_{engaccs} = P_{eng} + P_{accs}$ )	$P_{engaccs} = KPea * Pmax * (Paccs\_a1 + (Paccs\_a0 - Paccs\_a1) * \frac{RPM - RPMIdle}{RPM100 - RPMIdle})$	kW
KPea	Calibration factor	–
Pmax	Rated engine power	kW
Paccs_a1	$Paccs\_a1 = \frac{-b + \sqrt{b^2 - 4 * a * c}}{2 * a}$ $\begin{cases} a = \zeta_b * ehp * kPea^2 * Pmax * \frac{100 - PctPeng}{100} \\ b = \zeta_b * kPea * Pmax \\ c = -\alpha \end{cases}$	–
$\zeta_b$	Engine efficiency depends on the technology type (gasoline versus diesel)	mL/kW/s
ehp	Engine horsepower	hp
$\alpha$	Fuel consumption at Idling	mL/s
Paccs_a0	Ratio of engine and accessories drag to rated engine power when traveling at 100 km/h	
PctPeng	Percentage of the engine and accessories power used by the engine (Default = 80 %)	%
Engine speed (RPM)	$RPM = a0 + a1 * SP + a2 * SP^2 + a3 * SP^3$ $SP = \max(20, v)$	Rev/min
v	Vehicle speed	m/s
a0–a3	Model parameter (Table 6.4)	–
RPM100	Engine speed at 100 km/h	Rev/min
RPMIdle	Idle engine speed	Rev/min
Traction power ( $P_{tr}$ )	$P_{tr} = \frac{v(Fa + Fg + Fc + Fr + Fi)}{1000}$	kW
Fa	Aerodynamic forces	N
Fg	Gradient forces	N
Fc	Curvature forces	N
Fr	Rolling resistance forces	N
Fi	Inertial forces	N

appropriate calibration, adequately predicted the fuel consumption of five different vehicle classes under different operating, weather, and pavement conditions. Also, because the key characteristics of representative vehicles used in the current HDM 4 model vary substantially from those used in the U.S., the current model (i.e., without calibration) predicted lower fuel consumption than actually consumed. The calibrated HDM 4 fuel consumption model is listed in Tables 6.8, 6.9, 6.10, 6.11, 6.12 and 6.13.



**Table 6.3** Current HDM 4 traction forces model (2003)

Name	Description	Unit
Aerodynamic forces (Fa)	$Fa = 0.5 * \rho * CDmult * CD * AF * v^2$	N
CD	Drag coefficient	–
CDmult	CD multiplier	–
AF	Frontal area	m <sup>2</sup>
$\rho$	Mass density of the air	Kg/m <sup>3</sup>
v	Vehicle speed	m/s
Gradient forces (Fg)	$Fg = M * GR * g$	N
M	Vehicle weight	Kg
GR	Gradient	radians
g	The gravity	m/s <sup>2</sup>
Curvature forces (Fc)	$Fc = \max(0, \frac{(\frac{Mv^2}{R} - M * g * e)^2}{Nw * Cs} * 10^{-3})$	N
R	curvature radius	m
Superelevation (e)	$e = \max(0, 0.45 - 0.68 * Ln(R))$	m/m
Nw	Number of wheels	–
Tire stiffness (Cs)	$Cs = KCS * [a0 + a1 * \frac{M}{Nw} + a2 * (\frac{M}{Nw})^2]$	kN/rad
KCS	Calibration factor	–
a0–a2	Model parameter (Table 6.5)	
Rolling resistance (F <sub>r</sub> )	$Fr = CR2 * FCLIM * (b11 * Nw + CR1 * (b12 * M + b13 * v^2))$	N
CR1	Rolling resistance tire factor	–
Rolling resistance parameters (b11, b12, b13)	$\begin{cases} b11 = 37 * Dw \\ b12 = \begin{cases} 0.067/Dw & \text{old tires} \\ 0.064/Dw & \text{latest tires} \end{cases} \\ b13 = 0.012 * Nw/Dw^2 \end{cases}$	–
Rolling resistance surface factor	$CR2 = Kcr2[a0 + a1 * Tdsp + a2 * IRI + a3 * DEF]$	–
Kcr2	Calibration factor	–
a0–a3	Model coefficient (Table 6.6)	–
Tdsp	Texture depth using sand patch method	mm
IRI	International roughness index	m/km
DEF	Benkelman Beam rebound deflection	mm
Climatic factor	$FCLIM = 1 + 0.003 * PCTDS + 0.002 * PCTDW$	–
PCTDS	Percentage driving on snow	–
PCTDW	Percentage driving on wet surface	–
Inertial forces (F <sub>i</sub> )	$Fi = M * (a0 + a1 * \arctan(\frac{av}{v})) * a$	N
a0–a2	Model parameter (Table 6.7)	–

**Table 6.4** Engine speed model parameters for the current HDM 4 model (2003)

Vehicle Type	Engine speed			
	a0	a1	a2	a3
Motorcycle	-162	298.86	-4.6723	-0.0026
Small car	1910	-12.311	0.2228	-0.0003
Medium car	1910	-12.311	0.2228	-0.0003
Large car	1910	-12.311	0.2228	-0.0003
Light delivery car	1910	-12.311	0.2228	-0.0003
Light goods vehicle	2035	-20.036	0.356	-0.0009
Four wheel drive	2035	-20.036	0.356	-0.0009
Light truck	2035	-20.036	0.356	-0.0009
Medium truck	1926	-32.352	0.7403	-0.0027
Heavy truck	1905	-12.988	0.2494	-0.0004
Articulated truck	1900	-10.178	0.1521	0.00004
Mini bus	1910	-12.311	0.2228	-0.0003
Light bus	2035	-20.036	0.356	-0.0009
Medium bus	1926	-32.352	0.7403	-0.0027
Heavy bus	1926	-32.352	0.7403	-0.0027
Coach	1926	-32.352	0.7403	-0.0027

Source Bennett and Greenwood (2003)

**Table 6.5** Cs model parameters for the current HDM 4 model (2003)

coefficient	≤2,500 kg		>2,500 kg	
	Bias	Radial	Bias	Radial
a0	30	43	8.8	0
a1	0	0	0.088	0.0913
a2	0	0	-0.0000225	-0.0000114
Kcs	1	1	1	1

Source Bennett and Greenwood (2003)

### 6.2.1.3 Effect of Pavement Conditions on Fuel Consumption

In this section, the sensitivity of fuel consumption (FC) to pavement conditions at 56, 89 and 112 km/h (35, 55 and 70 mph) is investigated. The pavement conditions considered are IRI, surface texture and pavement type. IRI is a measurement of “roughness” that has a wavelength of 0.5 m (1.65 ft) and more. Texture refers to the categories of microtexture, macrotexture, and megatexture, defined by Henry (Fig. 6.2).

**Table 6.6** CR2 model in the current HDM 4 model (2003)

Surface class	surface type	≤2,500 kg				>2,500 kg			
		a0	a1	a2	a3	a0	a1	a2	a3
Bituminous	AM or ST	0.5	0.02	0.1	0	0.57	0.04	0.04	1.34
Concrete	JC or GR	0.5	0.02	0.1	0	0.57	0.04	0.04	0
Unsealed	GR	1	0	0.075	0	1	0	0.075	0
Unsealed	–	0.8	0	0.1	0	0.8	0	0.1	0
Block	CB, BR or SS	2	0	0	0	2	0	0	0
Unsealed	SA	7.5	0	0	0	7.5	0	0	0

Source Bennett and Greenwood (2003)

**Table 6.7** Effective mass ratio model parameters for the current HDM 4 model (2003)

Vehicle type	Effect mass ratio model coefficients		
	a0	a1	a2
Motorcycle	1.1	0	0
Small car	1.14	1.01	399
Medium car	1.05	0.213	1260.7
Large car	1.05	0.213	1260.7
Light delivery car	1.1	0.891	244.2
Light goods vehicle	1.1	0.891	244.2
Four wheel drive	1.1	0.891	244.2
Light truck	1.04	0.83	12.4
Medium truck	1.04	0.83	12.4
Heavy truck	1.07	1.91	10.1
Articulated truck	1.07	1.91	10.1
Mini bus	1.1	0.891	244.2
Light bus	1.1	0.891	244.2
Medium bus	1.04	0.83	12.4
Heavy bus	1.04	0.83	12.4
Coach	1.04	0.83	12.4

Source Bennett and Greenwood (2003)

Chatti and Zaabar (2012) investigated the effect of pavement conditions using five instrumented vehicles to measure fuel consumption over different pavement sections with different pavement conditions. The analysis showed that the most important factor is surface roughness (IRI) followed by texture and pavement type. Table 6.14 presents the predictions by the calibrated HDM 4. The increase in FC was computed from the baseline IRI of 1 m/km (63.4 in./mile). The table was

**Table 6.8** Calibrated HDM 4 fuel consumption model (2012)

Name	Description	Unit
Fuel consumption (FC)	$FC = \frac{1000}{v} * (\max(\alpha, \zeta * P_{tot} * (1 + dFuel)))$	mL/km
v	Vehicle Speed	m/s
$\alpha$	Fuel consumption at idling (Table 6.10)	mL/s
Engine efficiency ( $\zeta$ )	$= \zeta_b \left( 1 + ehp \frac{(P_{tot} - P_{eng})}{P_{max}} \right)$	mL/kW/s
$\zeta_b$	Engine efficiency (Table 6.10)	mL/kW/s
Pmax	Rated engine power (Table 6.10)	kW
ehp	Engine horsepower (Table 6.10)	hp
dFuel	Excess fuel due to congestion as a ratio (default = 0)	Dimensionless
Total power ( $P_{tot}$ )	$P_{tot} = \frac{P_{tr}}{edt} + P_{accs} + P_{eng}$ for $P_{tr} \geq 0$ , uphill/level $P_{tot} = edtP_{tr} + P_{accs} + P_{eng}$ for $P_{tr} < 0$ , downhill	kW
edt	Drive-train efficiency factor (Table 6.10)	Dimensionless
$P_{eng}$	Power required to overcome internal engine friction (80 percent of the engine and accessories power)	kW
Engine and accessories power ( $P_{engaccs} = P_{eng} + P_{accs}$ )	$P_{engaccs} = KPea * P_{max} * (P_{accs\_a1} + (P_{accs\_a0} - P_{accs\_a1}) * \frac{RPM - RPM_{Idle}}{RPM100 - RPM_{Idle}})$	kW
KPea	Calibration factor (Table 6.10)	Dimensionless
Paccs_a1	$P_{accs\_a1} = \frac{-b + \sqrt{b^2 - 4 * a * c}}{2 * a}$ $\begin{cases} a = \zeta_b * ehp * kPea^2 * P_{max} * \frac{100 - PctPeng}{100} \\ b = \zeta_b * kPea * P_{max} \\ c = -\alpha \end{cases}$	Factor
Paccs_a0	Ratio of engine and accessories drag to rated engine power when traveling at 100 km/h (Table 6.10)	Dimensionless
PctPeng	Percentage of the engine and accessories power used by the engine (Default = 80 %)	%
Engine speed (RPM)	$RPM = a0 + a1 * SP + a2 * SP^2 + a3 * SP^3$ $SP = \max(20, v)$	Rev/min
a0–a3	Model parameter (Table 6.10)	
RPM100	Engine speed at 100 km/h	Rev/min
RPMIdle	Idle engine speed (Table 6.10)	Rev/min
Traction power ( $P_{tr}$ ) (Table 6.9)	$P_{tr} = \frac{v(Fa + Fg + Fc + Fr + Fi)}{1000}$	kW

generated at 17 °C (62.6 °F) when the mean profile depth is 1 mm (0.04 in.) and grade is 0 %.

The analysis assumed that there is no interaction between the effect of roughness (unevenness) and surface texture given that their wavelength ranges are independent. The model showed pavement surface texture has an effect on fuel consumption only for heavier trucks. For example, a 1 mm decrease in mean profile depth will result in decrease in fuel consumption of 2.25 and 1.5 % at 56 and 88 km/h (35 and 55 mph) speeds, respectively.

**Table 6.9** Calibrated HDM 4 traction forces model (2012)

Name	Description	Unit
Aerodynamic forces (Fa)	$Fa = 0.5 * \rho * CD * AF * v^2$	N
Mass density of the air ( $\rho$ )	$\rho = 0.0566 + 1.225 * (1 - 2.26 * 10^{-5} * ALT)^{4.225} - 0.00377 * TAIR$	Kg/m <sup>3</sup>
ALT	The altitude above sea level (Default = 200 m)	m
TAIR	Temperature of the air (Default = 15 °C)	°C
CD	Drag coefficient (Table 6.10)	dimensionless
AF	Frontal area (Table 6.10)	m <sup>2</sup>
Gradient forces (Fg)	$Fg = M * GR * g$	N
M	Vehicle weight (Table 6.10)	Kg
GR	Gradient	radians
g	Gravity (Default = 9.81)	m/s <sup>2</sup>
Curvature forces (Fc)	$Fc = \max(0, \frac{(M * R - M * g * e)^2}{Nw * Cs}) * 10^{-3}$	N
R	curvature radius (Default = 3000)	m
Superelevation (e)	$e = \max(0, 0.45 - 0.68 * Ln(R))$	m/m
Nw	Number of wheels (Table 6.10)	dimensionless
Tire stiffness (Cs)	$Cs = a0 + a1 * \frac{M}{Nw} + a2 * (\frac{M}{Nw})^2$	kN/rad
a0-a2	Model parameter (Table 6.10)	
Rolling resistance (Fr)	$Fr = CR2 * (b11 * Nw + CR1 * (b12 * M + b13 * v^2))$	N
CR1	Rolling resistance tire factor (Table 6.10)	factor
Rolling resistance parameters (b11, b12, b13)	$\begin{cases} b11 = 37 * WD \\ b12 = 0.064 / WD \\ b13 = 0.012 * Nw / WD^2 \end{cases}$	parameters
WD	Wheel diameter (Table 6.10)	m
CR2	$CR2 = Kcr2[a0 + a1 * Tdsp + a2 * IRI + a3 * DEF]$	factor
Kcr2	Calibration factor (Table 6.10)	factor
a0-a3	Model coefficient (Table 6.12)	dimensionless
Tdsp	Texture depth using sand patch method $Tdsp = 1.02 * MPD + 0.28$	mm
MPD	Mean Profile Depth	mm
IRI	International roughness index	m/km
Deflection (DEF)	$DEF = (TAIR/30) * (-0.05 + 0.415 * e^{-0.08847 * v})$	mm
Inertial forces (Fi)	$Fi = M * (a0 + a1 * \arctan(a2/v^3)) * acc$	N
Acc	Vehicle acceleration acceleration	m/s <sup>2</sup>
a0-a2	Model parameter (Table 6.13)	dimensionless

The analysis showed that there is no interaction between the effect of roughness and pavement type. The analysis also showed that the difference in fuel consumption between asphalt and concrete pavements could only be detected at low speed and for heavy and fully loaded light trucks in summer conditions. Heavy

**Table 6.10** Calibrated HDM 4 default values for engine, tire and vehicle characteristics

Vehicle class	Engine speed (RPM)			RPMIdle	$\alpha$ (mL/s)	$\xi_{\phi}$ (mL/kW/s)	ehp (hp)	Pmax (kW)	edt	
	a0	a1	a2							a3
SC	720.05	0.868	0.2006	-0.0007	800	0.65	0.096	0.05	130	0.91
MC	720.05	0.868	0.2006	-0.0007	800	0.65	0.096	0.05	130	0.91
LC	720.05	0.868	0.2006	-0.0007	800	0.65	0.096	0.05	130	0.91
LDV	589.6	-0.5145	0.0168	0.0019	500	0.65	0.072	0.05	90	0.91
LGV	589.6	-0.5145	0.0168	0.0019	500	0.65	0.072	0.05	90	0.91
FWD	982.37	3.6701	-0.1331	0.0019	500	0.65	0.072	0.25	95	0.91
LT	550.08	-3.0722	0.3798	-0.0018	500	0.7	0.062	0.1	150	0.86
MT	799.6	-5.3791	0.2077	0.00006	833.7	0.8	0.059	0.1	200	0.86
HT	799.6	-5.3791	0.2077	0.00006	833.7	0.9	0.059	0.1	350	0.86
AT	799.6	-5.3791	0.2077	0.00006	833.7	0.9	0.059	0.1	350	0.86
MiniB	720.05	0.868	0.2006	-0.0007	500	0.48	0.096	0.25	55	0.9
LB	550.08	-3.0722	0.3798	-0.0018	589.6	0.48	0.062	0.1	100	0.86
MB	799.6	-5.3791	0.2077	0.00006	833.7	0.7	0.059	0.1	200	0.86
HB	799.6	-5.3791	0.2077	0.00006	833.7	0.8	0.059	0.1	350	0.86
Coach	799.6	-5.3791	0.2077	0.00006	833.7	0.9	0.059	0.1	350	0.86

(continued)

Table 6.10 (continued)

Vehicle class	Paces_a0	PctPeng (%)	Fuel type	Number of axle	CD	AF (m <sup>2</sup> )	NW	M (tons)	WD (m)	Tire Type	CR1	Kcr2	Kpea
SC	0.2	80	P	2	0.42	2.16	4	1.9	0.62	Radial	1	0.5	0.25
MC	0.2	80	P	2	0.42	2.16	4	1.9	0.62	Radial	1	0.5	0.25
LC	0.2	80	P	2	0.42	2.16	4	1.9	0.62	Radial	1	0.5	0.25
LDV	0.2	80	P	2	0.5	2.9	4	2.54	0.7	Radial	1	0.67	0.49
LGV	0.2	80	P	2	0.5	2.9	4	2.54	0.7	Radial	1	0.67	0.49
FWD	0.2	80	P	2	0.5	2.8	4	2.5	0.7	Radial	1	0.58	0.56
LT	0.2	80	P	2	0.6	5	4	4.5	0.8	Radial	1	0.99	0.61
MT	0.2	80	P	2	0.6	5	6	6.5	0.8	Bias	1.3	0.99	0.61
HT	0.2	80	D	3	0.7	8.5	10	13	1.05	Bias	1.3	1.1	0.35
AT	0.2	80	D	5	0.8	9	18	13.6	1.05	Bias	1.3	1.1	0.35
MiniB	0.2	80	P	2	0.5	2.9	4	2.16	0.7	Radial	1	0.67	0.49
LB	0.2	80	P	2	0.5	4	4	2.5	0.8	Radial	1	0.99	0.61
MB	0.2	80	D	2	0.6	5	6	4.5	1.05	Bias	1.3	0.99	0.61
HB	0.2	80	D	3	0.7	6.5	10	13	1.05	Bias	1.3	1.1	0.35
Coach	0.2	80	D	3	0.7	6.5	10	13.6	1.05	Bias	1.3	1.1	0.35

SC, MC and LC Small, Medium and Large car; LDV and LGV Light delivery and goods vehicle; FWD Four wheel drive; LT, MT, HT and AT Light, Medium, Heavy and Articulated truck; MiniB, LB, MB and HB Mini, Light, Medium and Heavy bus; P petroleum; D diesel; Source Chatti and Zaabar (2012)

**Table 6.11** Parameters for tire stiffness (Cs) model in the calibrated HDM 4 model (2012)

Coefficient	<=2,500 kg		>2,500 kg	
	Bias	Radial	Bias	Radial
a0	30	43	8.8	0
a1	0	0	0.088	0.0913
a2	0	0	-0.0000225	-0.0000114

Source Chatti and Zaabar (2012)

**Table 6.12** Parameters for CR2 model in the calibrated HDM 4 model (2012)

Surface class	surface type	<=2,500 kg				>2,500 kg			
		a0	a1	a2	a3	a0	a1	a2	a3
Asphalt	AM or ST	0.5	0.02	0.1	0	0.57	0.04	0.04	1.34
Concrete	JC or GR	0.5	0.02	0.1	0	0.57	0.04	0.04	0

Source Chatti and Zaabar (2012)

**Table 6.13** Effective mass ratio model parameters for the calibrated HDM 4 model (2012)

Vehicle type	Effect mass ratio model coefficients		
	a0	a1	a2
Motorcycle	1.1	0	0
Small car	1.14	1.01	399
Medium car	1.05	0.213	1260.7
Large car	1.05	0.213	1260.7
Light delivery car	1.1	0.891	244.2
Light goods vehicle	1.1	0.891	244.2
Four wheel drive	1.1	0.891	244.2
Light truck	1.04	0.83	12.4
Medium truck	1.04	0.83	12.4
Heavy truck	1.07	1.91	10.1
Articulated truck	1.07	1.91	10.1
Mini bus	1.1	0.891	244.2
Light bus	1.1	0.891	244.2
Medium bus	1.04	0.83	12.4
Heavy bus	1.04	0.83	12.4
Coach	1.04	0.83	12.4

Source Chatti and Zaabar (2012)



**Table 6.14** The effect of roughness on fuel consumption

Speed	Vehicle class	Calibrated HDM 4 model																					
		Base (ml/km)		Adjustment factors from the base value						Base (mpg)		Adjustment factors from the base value											
		IRI (m/km)		2		3		4		5		6		1		2		3		4		5	
56 (km/h) or 35 (mph)	MC	70.14		1.03	1.05	1.08	1.10	1.13	33.53		0.97	0.95	0.93	0.91	0.88								
	Van	76.99		1.01	1.02	1.03	1.04	1.05	30.55		0.99	0.98	0.97	0.96	0.95								
	FWD	78.69		1.02	1.05	1.07	1.09	1.12	29.89		0.98	0.95	0.93	0.92	0.89								
	LT	124.21		1.01	1.02	1.04	1.05	1.06	18.94		0.99	0.98	0.96	0.95	0.94								
	AT	273.41		1.02	1.04	1.07	1.09	1.11	8.60		0.98	0.96	0.93	0.92	0.90								
	MC	83.38		1.03	1.05	1.08	1.10	1.13	28.21		0.97	0.95	0.93	0.91	0.88								
88 (km/h) or 55 (mph)	Van	96.98		1.01	1.02	1.03	1.04	1.05	24.25		0.99	0.98	0.97	0.96	0.95								
	FWD	101.29		1.02	1.04	1.07	1.09	1.11	23.22		0.98	0.96	0.93	0.92	0.90								
	LT	180.18		1.01	1.02	1.03	1.04	1.05	13.05		0.99	0.98	0.97	0.96	0.95								
	AT	447.31		1.02	1.03	1.05	1.06	1.08	5.26		0.98	0.97	0.95	0.94	0.93								
	MC	107.85		1.02	1.05	1.07	1.09	1.12	21.81		0.98	0.95	0.93	0.92	0.89								
	Van	128.96		1.01	1.02	1.03	1.03	1.04	18.24		0.99	0.98	0.97	0.97	0.96								
112 (km/h) or 70 (mph)	FWD	140.49		1.02	1.04	1.06	1.08	1.10	16.74		0.98	0.96	0.94	0.93	0.91								
	LT	251.41		1.01	1.02	1.02	1.03	1.04	1.02		1.02	1.03	1.04	0.97	0.96								
	AT	656.11		1.01	1.02	1.04	1.05	1.06	1.02		1.04	1.05	1.06	1.06	0.95	0.94							
	MC			1.01	1.02	1.04	1.05	1.06	1.02		1.04	1.05	1.06	1.06	0.95	0.94							

MC Medium Car; FWD Four Wheel Drive; LT Light Truck; AT Articulated Truck  
 Source Chatti and Zaabar (2012)

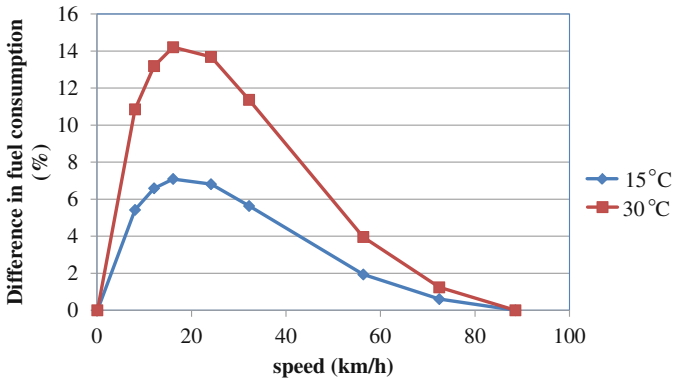

**Fig. 6.6** Difference between articulated truck fuel consumption driven over AC and PCC at 30 and 15 °C

trucks driven over AC pavements will consume about 4 % more fuel than over PCC pavement at 56 km/h (35 mph) in summer conditions as shown in Fig. 6.6. The effect of pavement type was statistically not significant at higher speeds. No data was available for heavy trucks in winter.

Reduction in vehicle fuel consumption is one of the main benefits that should be considered in technical and economic evaluations of road improvements considering its significance. Chatti et al. showed that a decrease in pavement roughness by 1 m/km (63.4 in./mile) will result in a 3 % decrease in the fuel consumption for passenger cars. This would save about 6 billion gallons of fuel per year of the 200 billion gallons consumed annually by the 255 million vehicles in the United States. In 2013, the average US gas price was about \$4/gallon, this translates to about \$24 billion dollars in savings.

### 6.2.2 Tire Wear

Although tire consumption is a significant component of the total VOC, especially for heavy vehicles, unlike fuel consumption, it has received much less attention. For example, it was found in New Zealand that tire costs constitute about 18 % of the VOC for heavy trucks, compared to only 5 % for passenger cars (Bennett and Greenwood 2003). Cost associated with tire wear has been affected by changes in tire design and technology in the tire manufacturing. Radial design and belted construction have increased the mileage life of tires, but increased prices have offset these gains to some extent (Zaniewski et al. 1982). There are two types of models which have been developed for predicting tire consumption: (1) empirical, which can be developed from fleet survey data, and (2) mechanistic, which relate tire consumption to the fundamental equations of motion and are developed from

controlled experiments. This section briefly reviews some of the major tire consumption models that have been developed.

### 6.2.2.1 Empirical Models

Winfrey developed tables for calculating tire wear cost per mile. The tire wear cost was a function of vertical and horizontal curves, and speed changes (Winfrey 1969). In 1973, the U.S. Forest Service funded a project to develop tire wear predictions (based on the slip energy concept) from measurable tire/road interactions for use in a VOC model for the national forest service road system. Zaniewski et al. (1982) developed a new model based on the slip energy concept to calculate tire wear and then present the results in tabular format. The most current models follow a mechanistic modeling approach to develop tread wear models.

### 6.2.2.2 Mechanistic Models

In the US, the tire wear model was developed by relating the volume of tread rubber worn to the amount of slip energy expanded at the pavement-tire interface. Equation (6.10) shows the form of the model:

$$V_{WR} = E_{SLIP}/S_{WE} \quad (6.10)$$

where:

- $V_{WR}$  Volume of worn tread rubber, in<sup>3</sup> (1 in<sup>3</sup> = 16.3871 mL)
- $E_{SLIP}$  Slip energy, lb-mi (1 lb-mi = 7,159 N m)
- $S_{WE}$  Slip energy-volume wear coefficient, (lb-mi)/in<sup>3</sup>

In this model two coefficients must be experimentally determined to be representative of specific tire and pavement surface types; these are slip and energy-volume wear coefficients.

The Saskatchewan Department of Highways and Transportation (SHT), Canada, adopted the following tire wear model.

$$TC = \frac{C_t N_t}{L_t K_{tr} K_{tt}} \quad (6.11)$$

where:

- $C_t$  Cost per tire, \$/tire
- $N_t$  Number of tires
- $K_{tr}$  Road roughness coefficient
- $K_{tt}$  Road texture coefficient
- $L_t$  Life of tire (km)

As shown in Eq. (6.11), the tire costs are a function of tire type, tire quality, road conditions, and tire maintenance practices. The effect of road surface on tire cost is primarily a function of road surface texture and roughness.

The World Bank HDM 3 model adopted the slip energy model to calculate the changes in tread wear as shown below:

$$\Delta TWT = K_0 \times \mu \times NFT \times \lambda \quad (6.12)$$

where:

$\Delta TWT$	Change in tread wear
$K_0$	Calibration factor reflecting pavement properties
$\mu$	Coefficient of friction
$NFT$	Normal force on the tire (N)
$\lambda$	Tire slip

For HDM 4, the model has been extended to include horizontal curvature force and traffic interaction effects, as shown below (Bennett and Greenwood 2003).

The general form of the tire consumption model is the following:

$$TC = \frac{NW * EQNT}{MODFAC} \quad (6.13)$$

where:

TC	Tire consumption per vehicle (%/km)
NW	Number of wheels
EQNT	Equivalent new tire (%/km)
MODFAC	Tire life modification factor

Tables 6.15, 6.16 and 6.17 summarize the HDM 4 tire wear model (Bennett and Greenwood 2003). The tire wear is a function of the forces applied on the tire. These forces are normal, lateral and circumferential forces. The latter include the aerodynamic, gradient and rolling resistance forces. These forces are functions of vehicle characteristics, pavement conditions, and climate. Bennett and Greenwood (2003) noted that, when testing the model, the values for C0tc (tire wear rate constant) were found to be too low and resulted in an unreasonably high tire life. Therefore, due to the problems with this model, an interim model was adopted for HDM 4. A constant was added to the EQNT equation in Table 6.15, which becomes as follows:

$$EQNT = \left( \frac{1 + RREC * NR}{1 + RTWR * NR} \right) * \frac{TWT}{VOL} + 0.0027 \quad (6.14)$$

**Table 6.15** The 2003 HDM 4 tire consumption model

Name	Description	Unit
Number of equivalent new tires (EQNT)	$EQNT = \frac{1+RREC*NR}{1+RTWR*NR} * \frac{TWT}{VOL}$	1/ 1,000 km
RREC	The ratio of the cost of retreads to new tires	–
RTWR	The life of a retreaded tire relative to a new tire	–
VOL	Tire volume	dm <sup>3</sup>
Number of retreading (NR)	$NR = \max(0, NR0 * e^{(-0.03224*RImod)} - 1)$	–
NR0	The base number of retreads for very smooth, tangent roads (Table 6.16)	–
RImod	Model Parameter (Table 6.16)	–
Total change in tread wear (TWT)	$TWT = C_{0tc} + C_{tcte} \times TE$	dm <sup>3</sup> / 1,000 km
C <sub>0tc</sub>	The tread <sup>3</sup> wear rate constant (Table 6.16)	dm <sup>3</sup> / 1,000 km
C <sub>tcte</sub>	The tread wear coefficient (Table 6.16)	dm <sup>3</sup> / MNm
The tire energy (TE)	$TE = \frac{CFT^2 + LFT^2}{NFT}$	MNm/ 1,000 km
The circumferential force on the tire (CFT)	$CFT = \frac{(1+CTCON*dFUEL)*(Fa+Fr+Fg)}{NW}$	N
CTCON	The incremental change of tire consumption related to congestion.	–
dFUEL	The incremental change of fuel consumption related to congestion	–
Fa	The aerodynamic forces	N
Fr	The rolling resistance forces	N
Fg	The gradient forces	N
The lateral force on the tire (LFT)	$LFT = \frac{Fc}{NW}$	N
Fc	The curvature forces	N
NW	Number of wheels	–
The normal force on the tire (NFT)	$NFT = \frac{M*g}{NW}$	N
M	Vehicle mass	kg
g	Gravity	m/sec <sup>2</sup>
Tire life medication factor (MODFAC)	$MODFAC = VEHFAC * TYREFA * CONFAC$	–
VEHFAC	A vehicle specific modification factor (Table 6.16)	–
TYREFAC	A tire type modification factor (see Table 6.17)	–
Congestion modification factor (CONFAC)	$CONFAC = \begin{cases} 0.7 & VCR < 0.85 \\ 1.0 & VCR \geq 0.85 \end{cases}$	–

Source Bennett and Greenwood (2003)

**Table 6.16** Tread wear rate constants for the 2003 HDM 4 tire consumption model

Vehicle type	$C_{0tc}$ ( $\text{dm}^3/1000 \text{ km}$ )	$C_{1cte}$ ( $\text{dm}^3/\text{MNm}$ )	RImod	NR0	VEHFAC
Motorcycle	0.00639	0.0005	IRI	1.3	2
Small car	0.02616	0.00204	IRI	1.3	2
Medium car	0.02616	0.00204	IRI	1.3	2
Large car	0.02616	0.00204	IRI	1.3	2
Light delivery car	0.024	0.00187	IRI	1.3	2
Light goods vehicle	0.024	0.00187	IRI	1.3	2
Four wheel drive	0.024	0.00187	IRI	1.3	2
Light truck	0.024	0.00187	IRI	1.3	2
Medium truck	0.02585	0.00201	min(7, IRI)	1.3	1
Heavy truck	0.03529	0.00275	7	1.3	1
Articulated truck	0.03988	0.00311	min(7, IRI)	1.3	1
Mini bus	0.024	0.00187	IRI	1.3	2
Light bus	0.02173	0.00169	IRI	1.3	2
Medium bus	0.02663	0.00207	7	1.3	1
Heavy bus	0.03088	0.00241	min(7, IRI)	1.3	1
Coach	0.03088	0.00241	min(7, IRI)	1.3	1

Source Bennett and Greenwood (2003)

**Table 6.17** Tire type modification factor

Tire type	Paved roads	Unpaved roads	
		IRI $\leq$ 6 m/Km	IRI $>$ 6 m/Km
Bias	1	1	1
Radial	1.25	1.2	1

Source Bennett and Greenwood (2003)

The tire life modification factors were proposed by Harrison and Aziz (1998). They depend on the roughness, tire type and congestion level and are calculated using the equation described in Table 6.15.

Recently, Chatti and Zaabar (2012) calibrated the HDM 4 model to the United States conditions. The analysis showed that the HDM 4 tire consumption model, after appropriate calibration, adequately predicted the tire consumption of two different vehicle classes. Also, because the key characteristics of representative vehicles used in the current HDM 4 model vary substantially from those used in the U.S., the current model (i.e., without calibration) predicted lower tire consumption than actually consumed. The calibrated HDM 4 tire wear model is listed in Tables 6.18, 6.19, 6.20, 6.21 and 6.22.

**Table 6.18** Calibrated HDM 4 tire consumption model

Name	Description	Unit
Number of equivalent new tires (EQNT)	$EQNT = \frac{TWT}{10 \times VOL}$	% new tire/km
VOL	Tire volume (Table 6.22)	dm <sup>3</sup>
Total change in tread wear (TWT)	$TWT = C_{0tc} + C_{tcte} \times TE$	dm <sup>3</sup> /1,000 km
C <sub>0tc</sub>	The tread wear rate constant (Table 6.22)	dm <sup>3</sup> /1,000 km
C <sub>tcte</sub>	The tread wear coefficient (Table 6.22)	dm <sup>3</sup> /MNm
The tire energy (TE)	$TE = \frac{CFT^2 + LFT^2}{NFT}$	MNm/ 1,000 km
The circumferential force on the tire (CFT)	$CFT = \frac{(1 + CTCON * dFUEL) * (Fa + Fr + Fg)}{NW}$	N
CTCON	The incremental change of tire consumption related to congestion (Default = 0)	Ratio
dFUEL	The incremental change of fuel consumption related to congestion (Default = 0)	Ratio
Fa	The aerodynamic forces (Table 6.19)	N
Fr	The rolling resistance forces (Table 6.19)	N
Fg	The gradient forces (Table 6.19)	N
The lateral force on the tire (LFT)	$LFT = \frac{Fc}{NW}$	N
Fc	The curvature forces (Table 6.19)	N
Nw	Number of wheels (Table 6.22)	Dimensionless
The normal force on the tire (NFT)	$NFT = \frac{M * g}{NW}$	N
M	Vehicle mass (Table 6.22)	kg
G	Gravity (Default = 9.81)	m/sec <sup>2</sup>

Source Chatti and Zaabar (2012)

### 6.2.2.3 Effect of Pavement Conditions on Tire Wear

In this section, the sensitivity of tire wear to pavement conditions at 56, 89 and 112 km/h (35, 55 and 70 mph) is investigated. The pavement conditions considered are IRI.

Table 6.23 presents the increase in tire wear as a function of IRI for all vehicle classes at 56, 88 and 112 km/h (35, 55 and 70 mph) caused by a change in IRI from the baseline condition of IRI = 1 m/km (63.4 in./mile). The table was generated at 17 °C (62.6 °F) when the mean profile depth is 1 mm (0.04 in.) and grade is 0 % using the calibrated HDM 4 model (Chatti and Zaabar 2012). These data show, for the same IRI value, that tire wear increases with increasing speed, and that the roughness effect is higher at higher speeds.

Chatti and Zaabar (2012) showed that a decrease in pavement roughness by 1 m/km (63.4 in./mile) will result in about 1 percent decrease in the tire wear for passenger cars. Assuming that the average annual kilometrage (mileage) for a

**Table 6.19** Calibrated HDM 4 traction forces model

Name	Description	Unit
Aerodynamic forces ( $F_a$ )	$F_a = 0.5 * \rho * CD * AF * v^2$	N
Mass density of the air ( $\rho$ )	$\rho = 0.0566 + 1.225 * (1 - 2.26 * 10^{-5} ALT)^{4.225} - 0.00377 * TAIR$	Kg/m <sup>3</sup>
$ALT$	The altitude above sea level (Default = 200 m)	m
$TAIR$	Temperature of the air (Default = 15 °C)	°C
$CD$	Drag coefficient (Table 6.22)	dimensionless
$AF$	Frontal (Table 6.22)	m <sup>2</sup>
Gradient forces ( $F_g$ )	$F_g = M * GR * g$	N
$M$	Vehicle weight (Table 6.22)	Kg
$GR$	Gradient	radians
$g$	Gravity (Default = 9.81)	m/s <sup>2</sup>
Curvature forces ( $F_c$ )	$F_c = \max(0, \frac{(\frac{Mv^2}{R} - M * g * e)^2}{Nw * Cs}) * 10^{-3}$	N
$R$	Curvature radius (Default = 3,000)	m
Superelevation ( $e$ )	$e = \max(0, 0.45 - 0.68 * Ln(R))$	m/m
$Nw$	Number of wheels (Table 6.22)	Dimensionless
Tire stiffness ( $C_s$ )	$C_s = a_0 + a_1 * \frac{M}{Nw} + a_2 * (\frac{M}{Nw})^2$	kN/rad
$a_0$ – $a_2$	Model parameter (Table 6.20)	
Rolling resistance ( $F_r$ )	$F_r = CR2 * (b11 * Nw + CR1 * (b12 * M + b13 * v^2))$	N
$CR1$	Rolling resistance tire factor (Table 6.22)	Factor
Rolling resistance parameters ( $b11, b12, b13$ )	$\begin{cases} b11 = 37 * WD \\ b12 = 0.064 / WD \\ b13 = 0.012 * Nw / WD^2 \end{cases}$	Parameters
$WD$	Wheel diameter (Table 6.22)	m
$CR2$	$CR2 = Kcr2[a_0 + a_1 * Tdsp + a_2 * IRI + a_3 * DEF]$	Factor
$Kcr2$	Calibration factor (Table 6.22)	Factor
$a_0$ – $a_3$	Model coefficient (Table 6.21)	Dimensionless
$Tdsp$	Texture depth using sand patch method $Tdsp = 1.02 * MPD + 0.28$	mm
$MPD$	Mean Profile Depth	mm
$IRI$	International roughness index	m/km
Deflection ( $DEF$ )	$DEF = (TAIR/30) * (-0.05 + 0.415 * e^{-0.08847 * v})$	mm

Source Chatti and Zaabar (2012)

passenger car is 24,000 km (15,000 miles) and the average price of a tire is \$100, the 255 million vehicles will consume about \$32.1 billion per year. Therefore, a decrease in IRI by 1 m/km (63.4 in./mile) will save 321 million dollars per year.



**Table 6.20** Parameters for tire stiffness (Cs) model in the calibrated HDM 4 model (2012)

coefficient	<=2,500 kg		>2,500 kg	
	Bias	Radial	Bias	Radial
a0	30	43	8.8	0
a1	0	0	0.088	0.0913
a2	0	0	-0.0000225	-0.0000114

Source Chatti and Zaabar (2012)

**Table 6.21** Parameters for CR2 model in the calibrated HDM 4 tire wear model (2012)

Surface class	Surface type	<=2,500 kg				>2,500 kg			
		a0	a1	a2	a3	a0	a1	a2	a3
Asphalt	AM or ST	0.5	0.02	0.1	0	0.57	0.04	0.04	1.34
Concrete	JC or GR	0.5	0.02	0.1	0	0.57	0.04	0.04	0

Source Chatti and Zaabar (2012)

### 6.2.3 Repair and Maintenance Costs

Vehicle repair/maintenance costs are mainly comprised of two components: Parts consumption and labor hours. The current models can be grouped into empirical- and mechanistic-based models. The only available U.S. models are also those of the TRDF developed by Zaniewski et al. (1982).

The most recent models have been developed outside the U.S. The relevant models are:

- The World Bank’s HDM 3 and 4 models;
- Saskatchewan models (Canada);
- South African model;
- Swedish VETO models.

This section briefly reviews some of the major repair and maintenance costs models that have been developed.

#### 6.2.3.1 Empirical Models

Winfrey (1969) presented maintenance costs based on the results of surveys. These were updated by Claffey (1971). Zaniewski et al. (1982) further updated costs for maintenance and repair at constant speed at level terrain in good condition by multiplying Winfrey’s costs by the ratio of current overall maintenance and repair costs to Winfrey’s overall costs and listing the costs in Tables. The results from the TRDF study were generated for a Pavement Serviceability Index (PSI) of 3.5 (IRI was not the accepted standard roughness index at that time). To include the effect of

**Table 6.22** Calibrated HDM 4 default values for tire and vehicle characteristics—Tire wear

Vehicle class	NW	M (tons)	Kcr2	CD	AF (m <sup>2</sup> )	WD	Tire Type	CR1	C0tc (dm <sup>3</sup> /1000 km)	Ctcte (dm <sup>3</sup> /MNm)	VOL (dm <sup>3</sup> )
SC	4	1.9	0.5	0.42	1.9	0.62	Radial	1	0.01747	0.001	1.4
MC	4	1.9	0.5	0.42	1.9	0.62	Radial	1	0.01747	0.001	1.4
LC	4	1.9	0.5	0.42	1.9	0.62	Radial	1	0.01747	0.001	1.4
LDV	4	2.54	0.67	0.5	2.9	0.7	Radial	1	0.01602	0.00092	1.6
LGV	4	2.5	0.58	0.5	2.8	0.7	Radial	1	0.01602	0.00092	1.6
FWD	4	4.5	0.99	0.6	5	0.8	Radial	1	0.01602	0.00092	1.6
LT	6	6.5	0.99	0.6	5	0.8	Bias	1.3	0.02999	0.00099	6
MT	10	13	1.1	0.7	8.5	1.05	Bias	1.3	0.03829	0.00135	8
HT	18	13.6	1.1	0.8	9	1.05	Bias	1.3	0.04328	0.00153	8
AT	4	2.16	0.67	0.5	2.9	0.7	Radial	1	0.01747	0.00092	1.6
MiniB	4	2.5	0.99	0.5	4	0.8	Radial	1	0.01747	0.00092	1.6
LB	6	4.5	0.99	0.6	5	1.05	Bias	1.3	0.02999	0.00099	6
MB	10	13	1.1	0.7	6.5	1.05	Bias	1.3	0.03829	0.00135	8
HB	10	13.6	1.1	0.7	6.5	1.05	Bias	1.3	0.03829	0.00135	8

SC, MC and LC Small, Medium and Large car; LDV and LGV Light delivery and goods vehicle; FWD Four wheel drive; LT, MT, HT and AT Light, Medium, Heavy and Articulated truck; MiniB, LB, MB and HB Mini, Light, Medium and Heavy bus; P petroleum; D diesel; Source Chatti and Zaabar (2012)

**Table 6.23** Effect of roughness on tire wear rates

Speed	Vehicle CLASS (number of wheels)	Baseline conditions (%/km)	Baseline conditions (%/mile)	Adjustment factors from the baseline conditions				
		IRI (m/km)						
		1	2	3	4	5	6	
56 (km/h) or 35 (mph)	Medium car (4)	0.0013	0.0021	1.01	1.01	1.02	1.02	1.03
	Van (4)	0.0011	0.0017	1.00	1.01	1.01	1.02	1.02
	SUV (4)	0.0011	0.0017	1.01	1.02	1.03	1.04	1.05
	Light truck (4)	0.0012	0.0020	1.01	1.02	1.03	1.04	1.05
	Articulated truck (18)	0.0006	0.0010	1.01	1.01	1.02	1.02	1.03
88 (km/h) or 55 (mph)	Medium car (4)	0.0014	0.0022	1.01	1.02	1.03	1.04	1.05
	Van (4)	0.0013	0.0021	1.01	1.01	1.02	1.03	1.04
	SUV (4)	0.0013	0.0021	1.01	1.03	1.05	1.06	1.08
	Light truck (4)	0.0018	0.0029	1.01	1.02	1.04	1.05	1.06
	Articulated truck (18)	0.0007	0.0012	1.01	1.02	1.03	1.04	1.05
112 (km/h) or 70 (mph)	Medium car (4)	0.0015	0.0025	1.01	1.03	1.04	1.06	1.08
	Van (4)	0.0018	0.0028	1.01	1.02	1.03	1.04	1.04
	SUV (4)	0.0017	0.0027	1.02	1.04	1.06	1.08	1.10
	Light truck (4)	0.0029	0.0046	1.01	1.02	1.04	1.05	1.06
	Articulated truck (18)	0.0009	0.0015	1.01	1.02	1.03	1.04	1.06

pavement condition, Zaniewski et al. (1982) compiled the two different relationships that were established as part of the Brazilian study (Watanatada 1987) to estimate parts and labor expenses as a function of surface roughness and calculated adjustment factors (Table 6.24).

Papagiannakis (2000) provided the results of a study into heavy truck parts consumption. It was noted that there is a significant increase in the maintenance costs with vehicle age, and at the same time the percentage of the costs due to labor decreases. This indicates, not unexpectedly, an increase in the number of parts replaced as the vehicle ages. The parts consumption was affected by road roughness even at low levels (<2 IRI m/km). Also, considering the effect of roughness on vehicle maintenance, SHT, Canada adopted a vehicle maintenance cost model that relates maintenance costs to roughness:

**Table 6.24** Repair and maintenance costs adjustment factors reported in Zaniewski et al. (1982)

Serviceability Index	IRI (m/km)	Passenger cars and pick up trucks	Single unit trucks	2-S2 and 3-S2 Semi trucks
1	8.94	2.3	1.73	2.35
1.5	6.69	1.98	1.48	1.82
2	5.09	1.71	1.30	1.5
2.5	3.85	1.37	1.17	1.27
3	2.84	1.15	1.07	1.11
3.5	1.98	1.00	1.00	1.00
4	1.24	0.90	0.94	0.92
4.5	0.59	0.83	0.90	0.86

1 m/km = 63.4 in./mile

$$MC = M_{cf}K_{mr} \tag{6.15}$$

where:

- MC Maintenance cost (\$/km)
- $M_{cf}$  Average maintenance cost (\$/km)
- $K_{mr}$  Road roughness coefficient

HDM 3 allowed users to predict VOC using relationships derived from road user cost studies in Brazil, India, Kenya, and the Caribbean (Watanatada et al. 1987). The Brazil relationships were the ‘standard’ relationships in HDM 3. Equations (6.16)–(6.20) show the Brazilian model.

$$PARTS = COSP \times CKM^{kp} \times \exp(CSPIRI \times IRI) \quad \text{for } IRI \leq IRIOSP \tag{6.16}$$

$$PARTS = CKM^{kp} (a_0 + a_1 \times IRI) \quad , \text{ for } IRI > IRIOSP \tag{6.17}$$

$$a_0 = COSP \exp(CSPIRI \times IRIOSP)(1 - CSPIRI \times IRIOSP) \tag{6.18}$$

$$a_1 = COSP \times CSPIRI \exp(CSPIRI \times IRIOSP) \tag{6.19}$$

$$LH = COLH PARTS^{CLHPC} \exp(CLHIRI IRI) \tag{6.20}$$

where:

- PARTS Standardized parts consumption as a fraction of the replacement vehicle price per 1,000 km
- CKM Vehicle cumulative kilometer and it is calculated as half the lifetime kilometreage
- $a_0, a_1$  Model parameters
- $kp$  Model Constant (Table 6.25)
- IRI Roughness in IRI m/km

**Table 6.25** HDM 3 maintenance model parameters

Vehicle class	Parts model parameters				Labor model parameters		
	kp	COSP ( $\times 10^{-6}$ )	CSPIRIP ( $\times 10^{-3}$ )	IRIOSP	COLH	CLHPC	CLHIRI
Passenger car	0.308	32.49	178.1	9.2	77.14	0.547	0
Utility	0.308	32.49	178.1	9.2	77.14	0.547	0
Large bus	0.483	1.77	46.28	14.6	293.44	0.517	0.0715
Light and medium truck	0.371	1.49	3273.27	0	242.03	0.519	0
Heavy truck	0.371	8.61	459.03	0	301.46	0.519	0
Articulated truck	0.371	13.94	203.45	0	652.51	0.519	0

Source Bennett and Greenwood (2003)

- IRIOSP Transitional roughness beyond which the relationship between parts consumption and roughness is linear
- COSP Parts model constant
- CSPIRIP Parts model roughness coefficient
- LH Number of labor hours per 1,000 km
- COLH Labor model constant
- CLHIRI Labor model roughness coefficient

The Brazilian model actually incorporates several vehicle classes including passenger cars, utility vehicles, buses and trucks. For example, the HDM 3 maintenance model suggests parameters for parts and labor for all the above vehicle classes, as shown in Table 6.25.

The structure of the parts model as shown above is quite complicated because trucks were found to have a linear response to roughness while passenger cars, utility vehicles, and buses had an exponential response. Therefore, a linear relationship was adopted above a certain roughness level (IRIOSP).

The Council for Scientific and Industrial Research (CSIR) in South Africa developed models for parts and labor consumption (du Plessis 1989). The research can be grouped into two areas: Speed and roughness effects on parts consumption as well as labor costs. Equation (6.21) presents the speed effect on the total cost. Equation 6.22 presents the roughness effect on parts consumption. Equations 6.23 and 6.24 present the South African labor hours' relationships.

The South African model includes two separate equations for buses and trucks when modeling labor costs:

$$PCST = a_1 + a_2 \times v + \frac{a_3}{S} + a_4 \times v^2 \quad (6.21)$$

$$PARTS = \exp(-3.0951 + 0.4514 \ln CKM + 1.2935 \ln(13 IRI)) \times 10^3 \quad (6.22)$$

$$LH = 0.763 \exp(0.0715 IRI) \left( \frac{PARTS}{NVPLT} \right)^{0.517} \quad \text{for buses} \quad (6.23)$$

$$LH = \max \left( 3, -0.375 + 0.0715 \left( \frac{PARTS}{NVPLT} \right) + 0.182 IRI \right) \quad \text{for trucks} \quad (6.24)$$

where:

PCST	Maintenance cost in cents/km
$v$	Speed (km/h)
$a_1$ – $a_4$	Model constants
PARTS	Standardized parts consumption as a fraction of the replacement vehicle price per 1,000 km
CKM	Vehicle cumulative kilometer and it is calculated as half the lifetime kilometrage
IRI	Roughness in IRI m/km
LH	Labor hours per 1,000 km
NVPLT	The replacement vehicle price less tires

The key problem with this model is that it is sensitive to the assumed average speed. In fact, du Plessis (1989) proved that there is a huge difference in the parts cost when assuming urban versus rural speed.

For HDM 4, the parts model was simplified over that used in HDM 3 (Bennett and Greenwood 2003). Equations (6.25)–(6.28) show the final model.

$$PARTS = (K0_{pc} [CKM^{kp} (a_0 + a_1 RI)] + K1_{pc})(1 + CPCON \times dFUEL) \quad (6.25)$$

$$RI = \max(IRI, \min(IRIO, a_2 + a_3 * IRI^{a_4})) \quad (6.26)$$

$$\begin{aligned} a_2 &= IRIO - a_5 \\ a_3 &= \frac{a_5}{IRIO^{\frac{IRIO}{a_5}}} \\ a_4 &= \frac{IRIO}{a_5} \end{aligned} \quad (6.27)$$

$$a_5 = IRIO - 3$$

$$LH = K0_{lh} (a_6 \times PARTS^{a_7}) + K1_{lh} \quad (6.28)$$

**Table 6.26** HDM 4 maintenance model parameters

Vehicle Type	Parts consumption model				Labor Model	
	CKM (km)	kp	$a_0 * 1E^{-6}$	$a_1 * 1E^{-6}$	$a_6$	$a_7$
Motorcycle	50,000	0.308	9.23	6.2	1161.42	0.584
Small car	150,000	0.308	36.94	6.2	1161.42	0.584
Medium car	150,000	0.308	36.94	6.2	1161.42	0.584
Large car	150,000	0.308	36.94	6.2	1161.42	0.584
Light delivery car	200,000	0.308	36.94	6.2	611.75	0.445
Light goods vehicle	200,000	0.308	36.94	6.2	611.75	0.445
Four wheel drive	200,000	0.371	7.29	2.96	611.75	0.445
Light truck	200,000	0.371	7.29	2.96	2462.22	0.654
Medium truck	240,000	0.371	11.58	2.96	2462.22	0.654
Heavy truck	602,000	0.371	11.58	2.96	2462.22	0.654
Articulated truck	602,000	0.371	13.58	2.96	2462.22	0.654
Mini bus	120,000	0.308	36.76	6.2	611.75	0.445
Light bus	136,000	0.371	10.14	1.97	637.12	0.473
Medium bus	245,000	0.483	0.57	0.49	637.12	0.473
Heavy bus	420,000	0.483	0.65	0.46	637.12	0.473
Coach	420,000	0.483	0.64	0.46	637.12	0.473

where,

- PARTS Standardized parts consumption as a fraction of the replacement vehicle price per 1,000 km
- $K0_{pc}$  Rotational calibration factor (default = 1.0)
- CKM Vehicle cumulative kilometer (Table 6.26)
- $a_0, a_1, kp$  Model Constants (Table 6.26)
- RI Adjusted roughness
- IRI Roughness in IRI m/km
- IRI0 Limiting roughness for parts consumption in IRI m/km (3 m/km)
- $a_2-a_5$  Model parameters
- $K1_{pc}$  Translational calibration factor (default = 0.0)
- CPCON Congestion elasticity factor (default = 0.1)
- dFUEL Additional fuel consumption due to congestion as a decimal
- LH Number of labor hours per 1,000 km
- $K0_{lh}$  Rotation calibration factor (default = 1)
- $K1_{lh}$  Translation calibration factor (default = 0)
- $a_6, a_7$  Model Constants (Table 6.26)

HDM 4 repair and maintenance model suggests parameters for parts and labor for all the above vehicle classes, as shown in Table 6.26.

**Table 6.27** Effect of operating conditions on VOC

VOC component	Effect on VOC component		
	Geometry	Roughness	Capacity
Fuel	✓	•	✓
Tire	–	✓	•
Oil	–	•	–
Parts	–	✓	•
Labor	–	✓	•
Depreciation and interest	✓	•	✓
Crew	✓	•	✓
Passenger time	✓	•	✓

*Index*—No effect • Minor effect ✓ Major effect

*Source* Papagiannakis (2000)

The model suggests eliminating the effects of roughness on parts consumption at low IRI. This is achieved by using Eqs. 6.26 and 6.27. However, Papagiannakis (2000) reported that even low magnitude roughness has an effect on parts consumption (Table 6.27).

### 6.2.3.2 Mechanistic Models

The only purely mechanistic model is the VETO model which was developed by the Swedish Road and Traffic Research Institute (VTI) (Hammarstrom and Karlsson 1991). It contains two approaches to the calculation of parts and maintenance labor: one empirical and one mechanistic. The former relies on the HDM Brazil relationships (Eqs. 6.16–6.20) while the latter employs a “wear index” for vehicle components. The mechanistic model is a detailed simulation of an idealized two-dimensional vehicle traveling over a surface with a specified profile. The model works on the basis that the wear and tear of components depends upon the product of the number of stress cycles they have been subjected to and the stress amplitude raised to the sixth power. The number of cycles is assumed to be constant per unit length of road (independent of roughness) while the stress amplitude for each component is proportional to the RMS value of the dynamic component of the wheel load. The model does not take into account the static load. The model was calibrated by looking at the life expectancy of different components. Only four components were studied and so the model does not yet provide a total cost calculation. Nevertheless, it is interesting to note that the change in vehicle wear with increasing roughness that it calculates is far higher than the change in parts cost predicted by the empirical model.

In spite of developing a complex model, Hammarström and Karlsson (1994) concluded that:



...it would probably be virtually impossible to develop a model which could be used for calculating the relationship between total repair costs and road unevenness, component by component.

Hammarström and Henrikson (1994) produced coefficients for calibrating HDM 3 to Swedish conditions. The study produced scaling constants (COSP) and was also able to examine how parts consumption changes with vehicle age (kp). However, it did not provide information on the effect of roughness on parts consumption.

### 6.2.3.3 Mechanistic-Empirical Models

Chatti and Zaabar (2012) developed a model that is a combination of a mechanistic-empirical (M-E) approach and updated TRDF study. The M-E approach to estimate the effect of pavement conditions on repair and maintenance costs only involves passenger cars and articulated trucks. Then, it uses the results from the 1982 TRDF study by Zaniewski et al. to estimate the costs for the other vehicle classes. The TRDF models were updated using macro-economic model corrections for overall (average) economic data (e.g., average labor hours for typical vehicles and average parts cost comparisons). This was done by multiplying the costs from the TRDF study (which take into account all the relevant factors; e.g. roughness, grade, speed) by the ratio of current overall maintenance and repair costs to those used in the TRDF study. Current overall Repair and Maintenance (R&M) costs were estimated using MDOT and TxDOT fleet databases. The inflation rate between 1982 and 2007 was calculated as the ratio of current overall average R&M costs to those reported in the TRDF study. Table 6.28 shows these costs, current R&M costs, and the inflation rate for different vehicle classes.

The 1982 database collected by Zaniewski et al. (1982) does not include medium trucks (6.350–11.793 metric tons or 14,000–26,000 lb) based on the US DOT Vehicle Inventory and Use Survey classification. However, the data collected as part of this study (especially the data collected from TxDOT) included all truck classes (light, medium, heavy and articulated trucks), and buses. Therefore, the average R&M costs for medium trucks and buses were assumed to be equal to those for heavy trucks.

The effect of roughness was accounted for using a similar approach used in Zaniewski et al. study (1982). First, the HDM 4 repair and maintenance equations were compiled for all vehicle classes for ranges of roughness levels (from 1 to 6 m/km by an increment of 0.5 m/km). Then, these values were compared to the baseline condition, which is assumed to be 2 m/km (PSI  $\approx$  3.5). The proportionate change from this baseline condition to the respective roughness level is the adjustment factor applied to the updated costs. Adjustment factors for each vehicle class and IRI value were calculated using Eqs. (6.29) and (6.30) and are summarized in Table 6.29. The HDM 4 model assumes no effect of roughness on parts consumption at low IRI (less than 3 m/km) which is achieved by using the smoothing relationship given in Eqs. (6.26) and (6.27) above. This assumption was

**Table 6.28** Repair and maintenance costs and inflation rates

Vehicle class	Average Cost (\$/km) × 10 <sup>-3</sup>		Average Cost (\$/mile) × 10 <sup>-3</sup>		Inflation ratio (1982–2007)	Average vehicle age † (yr)	Average vehicle odometer reading † (km)	Data points †
	Zaniewski et al. (1982)	Current cost † (2007)	Zaniewski et al. (1982)	Current cost † (2007)				
SC	21.44	40.23	34.3	64.37	1.56	9.23	96,215	680
MC	26		41.6					
	30.03		48.05					
Pick up	33.01	51.78	52.82	82.85	1.57	7.31	92,038	2764
LT	61.88	92.13	99	147.4	1.49	7.80	86,963	1536
MT	87.50 <sup>a</sup>	118.6	140 <sup>a</sup>	189.76	1.36	7.40	87,449	1831
HT	87.50	119.27	140	190.83	1.36	12.50	196,378	1735
AT	90.63	124.28	145	198.85	1.37	14.64	352,633	181
Buses	87.50 <sup>a</sup>	119.12	140 <sup>a</sup>	190.59	1.36	22.75	323,174	8

1 km = 0.62 mile

<sup>a</sup> Assumed equal to heavy truck cost

† Estimated using both Texas and Michigan DOT

SC, MC and LC small, medium and large car; LT, MT, HT and AT Light, medium, heavy and articulated truck

Source Chatti and Zaabar (2012)

**Table 6.29** Repair and maintenance costs adjustment factors

Vehicle Class	Adjustment factors										
	IRI (m/km)										
	1.0	1.5	2	2.5	3	3.5	4	4.5	5	5.5	6
SC	1.0	1.0	1.0	1.0	1.01	1.03	1.12	1.26	1.40	1.55	1.71
MC	1.0	1.0	1.0	1.0	1.01	1.03	1.12	1.26	1.40	1.55	1.71
LC	1.0	1.0	1.0	1.0	1.01	1.03	1.12	1.26	1.40	1.55	1.71
Pickup	1.0	1.0	1.0	1.0	1.01	1.03	1.12	1.26	1.40	1.55	1.71
LT	1.0	1.0	1.0	1.0	1.01	1.05	1.20	1.41	1.65	1.91	2.18
MT	1.0	1.0	1.0	1.0	1.01	1.04	1.15	1.32	1.50	1.69	1.90
HT	1.0	1.0	1.0	1.0	1.01	1.04	1.15	1.32	1.50	1.69	1.90
AT	1.0	1.0	1.0	1.0	1.01	1.03	1.14	1.29	1.45	1.62	1.80
Buses	1.0	1.0	1.0	1.0	1.02	1.06	1.24	1.52	1.83	2.17	2.53

1 m/km = 63.4 in./mile

SC, MC and LC Small, medium and large car; LT, MT, HT and AT Light, medium, heavy and articulated truck

Source Chatti and Zaabar (2012)

also reported in others studies (Poelman and Weir 1992) and was observed from the data that was collected as part of this study.

$$AF_i = \frac{COST(IRI_i)}{COST(2)} \tag{6.29}$$

$$COST(IRI_i) = PARTS(IRI_i) + LH(IRI_i) \tag{6.30}$$

where:

- $AF_i$  (%) Adjustment factor in percent
- $COST (IRI_i)$  Total cost per 1,000 km evaluated at  $IRI_i$
- $PARTS (IRI_i)$  Parts consumption per 1,000 km evaluated at  $IRI_i$  using Eq. (6.25)
- $LH (IRI_i)$  Labor cost per 1,000 km evaluated at  $IRI_i$  using Eq. (6.28)
- $IRI_i$  International Roughness Index in m/km

The mechanistic-empirical methodology consists of conducting fatigue damage analysis using numerical modeling of vehicle response. Its main assumption is that damage to vehicle suspension components follows a Miner’s rule type of fatigue accumulation (Poelman and Weir 1992; Hammarström and Henrikson 1994). A sensitivity analysis was performed to quantify the relationship between roughness level and vehicle suspension damage. The analysis consists of the following steps:

1. Generate an artificial road surface profile for a given roughness (IRI);
2. Estimate the response of the vehicle using numerical modeling of the vehicle;
3. Compute the induced damage to the vehicle suspension using a rainflow counting algorithm and Miner’s rule;
4. Repeat steps 1 through 3 for different roughness levels.

### Artificial Generation of Road Surface Profiles

Chatti and Zaabar (2012) used the following model to generate the pavement surface roughness profiles:

$$S_u(k) = c|k|^{-n} \quad (6.31)$$

where,

$S_u(k)$	Displacement spectral density, $m^3/cycle$
$N$	2.5
$K$	$\frac{n}{N\Delta} \quad n = 0, 1, \dots, (N - 1) = \text{Wavenumber}$
$N$	Number of samples in the profiles
$\Delta$	The distance interval between successive ordinates of the surface profile
$c$	Characterizes the roughness level

The constant  $c$  in Eq. (6.31) was found to be correlated with the IRI (Robson 1979) and could be estimated using Eq. (6.32):

$$c = 1.69 \times 10^{-8} (IRI)^2 \left( m^{1/2} cycle^{3/2} \right) \quad (6.32)$$

To generate a random road surface profile, a set of random phase angles uniformly distributed between 0 and  $2\pi$  is applied to the desired spectral density. Then, the inverse discrete Fourier transform was applied to the spectral coefficients (Cebon 1999).

### Dynamic Vehicle Simulation

As reported by Prem (2000) and Cebon (1999), several numerical models have been developed to predict the behavior of vehicles when traveling on irregular pavement surfaces. The models used by Chatti and Zaabar (2012) are based on quarter-vehicles represented by a second-order, two-degree-of-freedom, linear differential equation (Eq. 6.33), whereby the vehicle response is computed for the vertical orientation with the pavement surface profile as the excitation function (Fig. 6.7).

$$\begin{cases} m_u \ddot{x}_u - c_s (\dot{x}_s - \dot{x}_u) - k_s (x_s - x_u) + k_t (x_u - u) = 0 \\ m_s \ddot{x}_s + c_s (\dot{x}_s - \dot{x}_u) + k_s (x_s - x_u) = 0 \end{cases} \quad (6.33)$$

where,

$u(t)$	Road profile
$x_u$	Elevation of unsprung mass (axle)
$x_s$	Elevation of sprung mass (body)
$k_t$	Tire spring constant
$k_s$	Suspension spring constant

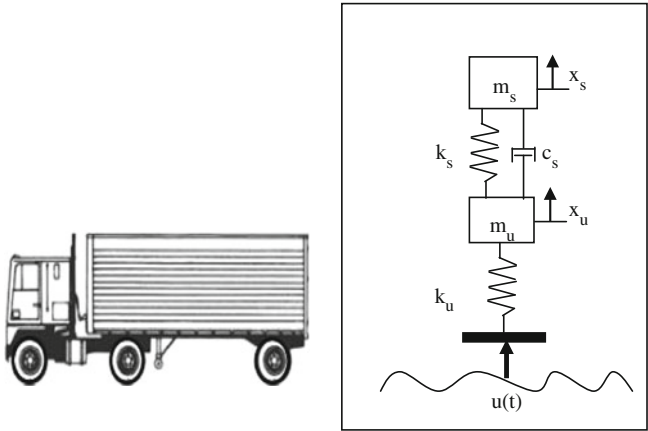
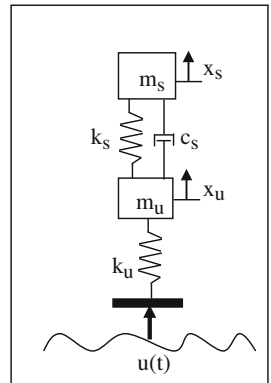

**Fig. 6.7** Schematic of two degrees of freedom quarter-car vehicle model. *Source* Chatti and Zaabar (2012)

- $m_u$     Unsprung mass
- $m_s$     Sprung mass
- $c_s$     Shock absorber constant

The ‘Quarter car’ parameters for a passenger car (Sayers and Karamihas 1998) and full truck with typical air and steel suspensions from (Cebon 1999) are given in Fig. 6.8.

Model parameters				
Constants		Truck		Car
Name	Unit	Steel	Air	-
$m_s$	Kg	4500	4500	250
$m_u$	Kg	500	500	40
$k_s$	MN/m	1	0.4	0.028
$k_t$	MN/m	2	2	0.125
$c_s$	KNs/m	20	20	2



**Fig. 6.8** Parameters for quarter-car vehicle model used. *Source* Chatti and Zaabar (2012)

### Vehicle Fatigue Damage Analysis

The total fatigue damage caused by the rainflow-counted load sequence is computed using Eqs. (6.34)–(6.36).

$$D = \sum_i \frac{1}{N_i} \quad (6.34)$$

$$N_i = C^{-1} U_i^{-\beta} \quad (6.35)$$

$$U_i = M_i - m_i^{RFC} \quad (6.36)$$

where,

$D$	Total fatigue damage
$N_i$	Number of cycles to failure at a given load level $i$
$U_i$	Load amplitude,
$C$	Fatigue limit
$B$	Fatigue exponent (Default 6.3)
$M_i^{RFC}$	Rainflow-counted load sequence

### Suspension Failure Threshold

Vehicle suspensions are generally replaced when certain signs of wear become evident to compromise the safety and comfort of drivers. Consequently, in Chatti and Zaabar (2012), the average life of car and truck suspensions for typical driving conditions was assumed to be about 160,000 km and 400,000 km, respectively. The amount of service life used up to that point was estimated using the following procedure:

1. Estimate the roughness (IRI) distribution of U.S. roads, with 1 m/km (63.4 in./mile) corresponding to a smooth road and 6 m/km to a very rough road.
2. Generate 30 road surface profiles for each of the IRI values;
3. Calculate the accumulated damage ( $D_{IRI}^i$ ) induced by each of the road profile generated in step 2 for a length of 1.6 km (1 mile) and assuming a value of 6.3 for  $\beta$  in Eq. (6.35).
4. Take the average value of the accumulated damage calculated for each profile set having the same IRI level.
5. Estimate the number of kilometers per IRI ( $L_{IRI}^i$ ) value using the distribution obtained in step 1 and assuming that the road length over which these vehicles are driven is 160,000 km (100,000 miles) and 400,000 km (250,000 miles) for cars and trucks respectively.
6. Compute the total accumulated damage using Eq. (6.37):

$$D_{replace} = \sum_{i=1}^N \left( \frac{\sum_{j=1}^{30} D_{IRI}^{ij}}{30} \times L_{IRI}^i \right) \quad (6.37)$$

Using the above procedure, the value reported in Chatti and Zaabar (2012) for  $D_{replace}$  is about 87.3 % at 112 km/h (70 mph) for cars and 62.2 % at 96 km/h (60 mph) for trucks.

### Repair and Maintenance Cost

The repair and maintenance cost for a given IRI level is calculated by dividing the accumulated damage corresponding to that IRI value by  $D_{replace}$  and multiplying the result by \$1,000 for cars and, \$3,000 and \$1,800 for air and steel suspensions of trucks, respectively. These costs corresponds to the price of a new suspension plus the required labor hours for replacement.

#### 6.2.3.4 Effect of Pavement Conditions on R&M

Table 6.30 and Fig. 6.9 summarize the increase in R&M costs per km for all vehicle classes due to IRI changes from the baseline condition of IRI = 1 m/km (63.4 in./mile) and grade of 0 %. The figure and the table indicates the following:

- The effect of roughness on repair and maintenance costs increases as speed increases.
- Roughness affects light trucks and SUV more than articulated truck s and passenger cars.

The results show that there is no effect of roughness up to IRI of 3 m/km. Beyond this range, an increase in IRI up to 4 m/km will increase R&M cost by 10 % for passenger cars and heavy trucks. At IRI of 5 m/km, this increase is up to 40 % for passenger cars and 50 % for heavy trucks. As an example, if we consider the IRI distribution of the U.S. road network, about 14 % of the roads have an IRI higher than 3 m/km. Assuming that the average annual mileage for a passenger car is 24,000 km (15,000 miles), and a total of 255 million cars travel on the US road network, the repair and maintenance cost for passenger cars in the U.S. can be estimated to be anywhere between 15 and 25 billion dollars per year (corresponding to vehicle speed ranging from 56 to 112 km/h, or 35 to 70 mph).

**Table 6.30** Effect of roughness on repair and maintenance costs

Speed	Vehicle Class	Average R&M cost <sup>a</sup> (\$/km)	Average R&M cost <sup>a</sup> (\$/mile)	Baseline conditions IRI (m/km)	Baseline conditions (\$/mile)	Adjustment factors from the baseline conditions					
						1	2	3	4	5	6
56 (km/h) Or 35 (mph)	MC	0.040	0.064	0.015	0.024	1.0	1.0	1.0	1.1	1.4	1.7
	Van	0.052	0.083	0.020	0.032	1.0	1.0	1.0	1.1	1.4	1.7
	SUV	0.052	0.083	0.020	0.032	1.0	1.0	1.0	1.2	1.7	2.3
	LT	0.058	0.092	0.021	0.034	1.0	1.0	1.0	1.2	1.7	2.2
	AT	0.124	0.199	0.046	0.074	1.0	1.0	1.0	1.1	1.5	1.8
88 (km/h) Or 55 (mph)	MC	0.040	0.064	0.019	0.030	1.0	1.0	1.0	1.1	1.4	1.7
	Van	0.052	0.083	0.025	0.040	1.0	1.0	1.0	1.1	1.4	1.7
	SUV	0.052	0.083	0.025	0.040	1.0	1.0	1.0	1.2	1.7	2.3
	LT	0.058	0.092	0.029	0.046	1.0	1.0	1.0	1.2	1.7	2.2
	AT	0.124	0.199	0.063	0.101	1.0	1.0	1.0	1.1	1.5	1.8
112 (km/h) Or 70 (mph)	MC	0.040	0.064	0.023	0.036	1.0	1.0	1.0	1.1	1.4	1.7
	Van	0.052	0.083	0.030	0.047	1.0	1.0	1.0	1.1	1.4	1.7
	SUV	0.052	0.083	0.030	0.047	1.0	1.0	1.0	1.2	1.7	2.3
	LT	0.058	0.092	0.035	0.057	1.0	1.0	1.0	1.2	1.7	2.2
	AT	0.124	0.199	0.077	0.123	1.0	1.0	1.0	1.1	1.5	1.8

1 m/km = 63.4 in./mile

<sup>a</sup> These costs are unit repair costs related only to damage from vibrations

Source Chhatti and Zaabar (2012)



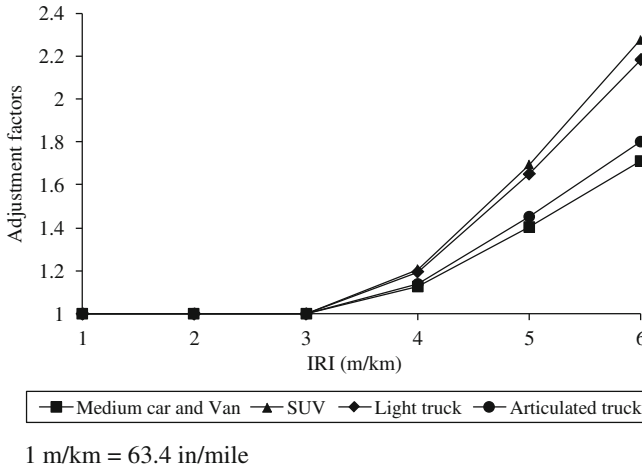

**Fig. 6.9** Effect of roughness on repair and maintenance costs. *Source* Chatti and Zaabar (2012)

## 6.2.4 Damage to Transported Goods

This section presents a methodology to estimate the effect of roughness features on damage to goods. A mechanistic-empirical approach to conduct fatigue damage analysis using numerical modeling of vehicle response and product vibrations is discussed. This is followed by case studies and results from the application of the mechanistic-empirical model.

### 6.2.4.1 Mechanistic-Empirical Approach

A sensitivity analysis was performed to quantify the relationship between roughness feature height and width to damage to goods. The analysis consists of the following steps:

1. Generate road surface profile and roughness features (transient events);
2. Estimate the vehicle response and the product vibration to these transient events;
3. Compute the induced damage to transported goods;
4. Repeat all steps for different heights and frequencies of roughness features.

#### Artificial Generation of Profiles and Roughness Features

The pavement surface roughness profiles were generated using Eqs. (6.31) and (6.32). The roughness features considered in this section are: faulting, breaks and curling in concrete pavements. To investigate their effect, these roughness features

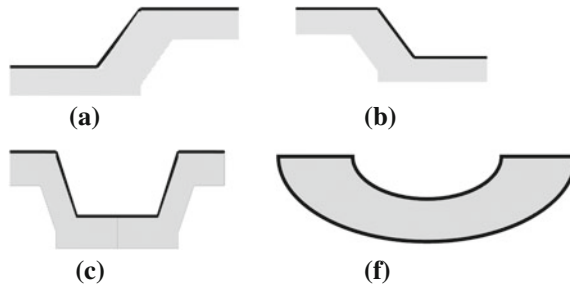

**Fig. 6.10** Schematic description of roughness features. **a** Curb, **b** step, **c** break, **d** curling

were artificially generated and superimposed on to the generated road surface profile (Zaabar and Chatti 2010). The resulting road profile over 1.6 km is:

$$u(x) = u_r(x) + u_f(x) \tag{6.38}$$

where,

$u(x)$  Total road surface profile

$u_r(x)$  Road surface profile

$u_f(x)$  Roughness features

$$\begin{cases} u_{jf}(x) & \frac{i*1600}{N} \leq x \leq \frac{i*1600}{N} + h; \quad i = 1 : N; \quad x + h < 1600 \text{ m} \\ 0 & \text{Otherwise} \end{cases}$$

$N$  Number of roughness features per 1.6 km

$H$  Width of the roughness features

$U_{jf}(x)$  Roughness feature (Fig. 6.10)

### Dynamic Vehicle Simulation

Trucks are modeled as a two-axle vehicle. Table 6.31 presents the parameter values for a “standard vehicle”.

### Product Vibration

In this section, we focused on the damage to horticultural produce. Models for horticultural produce are based on the principle of conservation of momentum (Fig. 6.11). They treat the collision of products in multi-layered packs with the surface as inelastic shocks.

**Table 6.31** Parameter Values for a “Standard Vehicle”

Name	Notation	Values	Unit
Moment of inertia about CG of body	I	31,000	Kg m <sup>-2</sup>
Mass of the vehicle body	M1	5,395	Kg
Distance from front axle to CG of body	R	3.5	m
Distance from rear axle to CG of body	S	1.09	m
Mass of front axle	M2	336	Kg
Mass of rear axle	M3	1,000	Kg
Front spring stiffness	K1	250,000	N m <sup>-1</sup>
Front spring viscous damping	C1 (bump) C1 (rebound)	1,000 4,000	N m <sup>-1</sup> s <sup>-1</sup>
Front spring Coulomb damping	B1	2,000	N
Rear spring stiffness	K2	1,295,000	N m <sup>-1</sup>
Rear spring viscous damping	C2 (bump) C2 (rebound)	4,000 4,000	N m <sup>-1</sup> s <sup>-1</sup>
Rear spring Coulomb damping	B2	4,000	N
Front tire stiffness	K3	1,564,000	N m <sup>-1</sup>
Front tire viscous damping	C3	1,000	N m <sup>-1</sup> s <sup>-1</sup>
Rear tire stiffness	K4	3,078,000	N m <sup>-1</sup>
Rear tire viscous damping	C4	2,000	N m <sup>-1</sup> s <sup>-1</sup>

Source Jones et al. (1991)

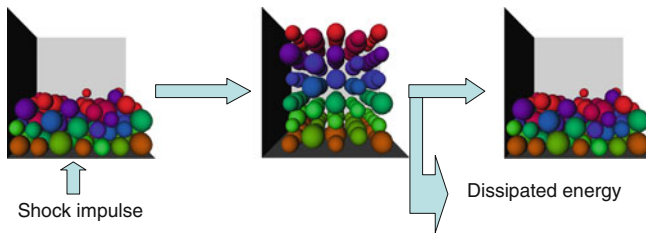
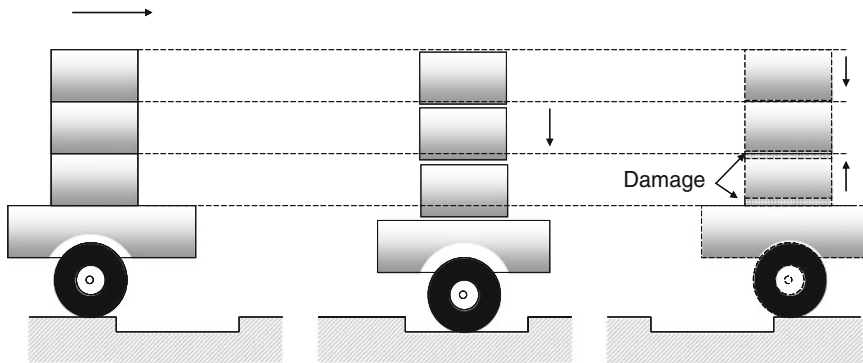

**Fig. 6.11** Collision of horticultural produce treated as inelastic shocks

**Product Damage Analysis**

According to the United States Department of Agriculture Economic Research Service, apples are the most popular in the United States, and no other fruit was consumed in as large of a quantity (Rich et al. 2008; Texas Department of Agriculture 2007). Therefore, only apples were considered in this section because including all products will be a cumbersome analysis.

The kinetic energy of the falling column is dissipated by bruising of apples at the various interfaces. The first collision will be between the truck bed and the first layer of the package. The second collision will be between the second layer and the layers beneath it (Fig. 6.12). This iterative process is repeated for all the layers. If



**Fig. 6.12** Road-vehicle-load interaction for multi-layered energy absorbing packages

the dissipated energy is larger than the energy resistance of the produce, damage will occur. If the percentage of the transported produce exceeds 5 %, then the height and/or the width of the roughness event are not acceptable. Apples are damaged when the frequency is less than 5 Hz and the dissipated energy into the apple exceeds  $6.4 \text{ ml J}^{-1}$  (Jones et al. 1991; Chesson and O'Brien 1971; Timm et al. 1998).

#### 6.2.4.2 Effect of Roughness Features on Damage to Transported Goods

To illustrate the various features of the method described above, the case study of US conditions has been examined. All road surface profiles were artificially generated at every 0.07 m. The generated road surface profiles were filtered out using a moving average filter with a baselength of 0.3 m for trucks representing the tire enveloping. Then, the truck model traveling at a constant speed of 110 km/h was applied to a 1.6 km of road surface profiles. For all case studies, the trip length was assumed constant and equal to the typical value in the US, i.e., 2,400 km (Hendrickson 2004). The effect of different combinations of roughness features magnitude and frequency for different trip lengths of concrete pavements on damage to goods was also investigated. Typical characteristics for trucks and packaging used to transport horticultural produce are given in Table 6.32.

#### Effect of Faulting on Damage to Goods

The first case study examines the effect of different combinations of faulting levels and frequencies per 1.6 km on damage to goods. The vehicle speed was the same for all the runs. Only jointed plain concrete pavement (JPCP) were considered in this analysis since Jointed Reinforced Concrete Pavement are no longer used in the US. The effect of suspension type on damage to goods was also investigated.

**Table 6.32** Summary of truck and packaging parameter values for horticultural produce

Parameter	Values
Trailer length (m)	16
Trailer width (m)	2.6
Trailer height (m)	4
Maximum allowable GVW (metric tonnes)	45.4
Maximum allowable payload (metric tonnes)	36.2
Packaging box length (m)	0.38
Packaging box width (m)	0.32
Packaging box height (mm)	0.38
Packaging box weight (kg)	10
Number of apples per box	120
Number of boxes per trailer	3,360
Packaging layout	Columns

**Fig. 6.13** Damage induced by different levels and counts of faulting

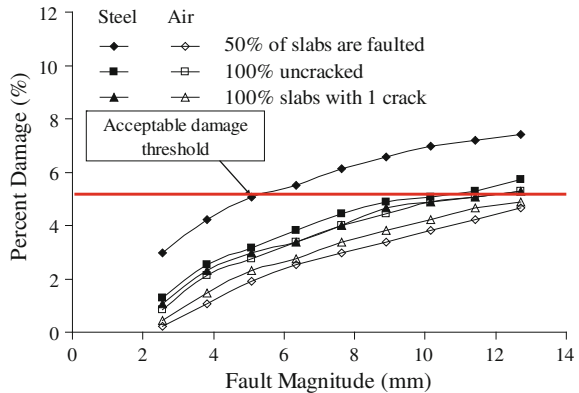
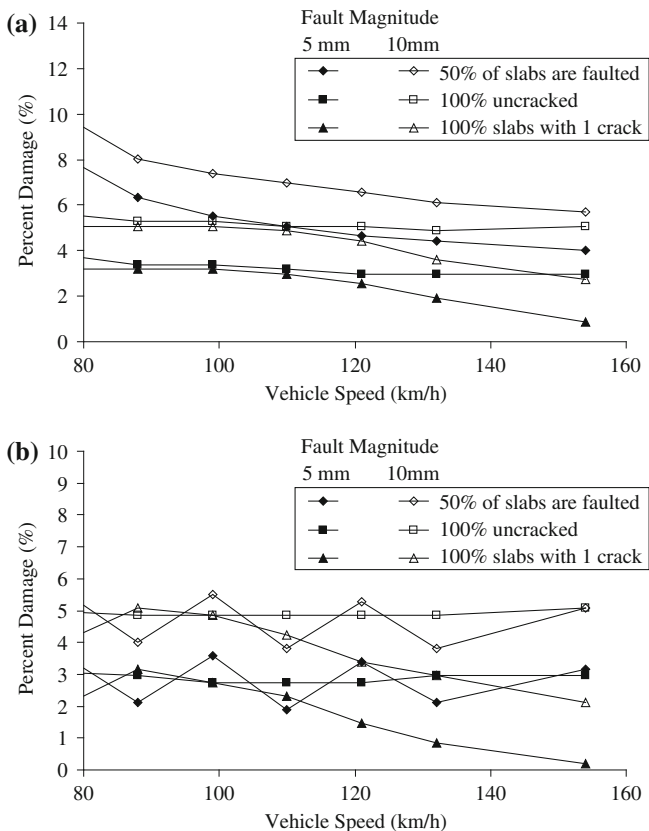

Figure 6.13 shows the increase in percent of damaged boxes as a function of fault magnitude.

It was noted that shorter spacing between faults in jointed concrete pavements will cause less damage to the goods transported in trucks with steel suspension. This observation is not true for trucks with air suspensions. It is believed that these observations were the result of the interaction between speed, profile wavelength content, resonant frequencies of trucks and goods. Figure 6.14 shows the effect of speed on damage to goods. It was observed:

*For trucks with steel suspensions (Fig. 6.14a)*

- High speed will cause less damage to goods than low speed except for the case where all the joints in the JPCP pavements are faulted.
- The difference between pavement conditions is even greater with lower speed.



**Fig. 6.14** Interaction effect between speed and fault counts on damage to apples. **a** Steel suspension, **b** air suspension

*For trucks with air suspensions (Fig. 6.14b)*

- In concrete pavements where 100 % of slabs are with 1 crack, high speed will cause less damage to goods than low speed.
- When all the joints in the JPCP pavements are faulted, the speed has no effect on damage to goods.

When 50 % of slabs are faulted, the multiple resonant frequencies of the truck model cause the curve to oscillate.

### Effect of Breaks on Damage to Goods

The second case study examines the effect of different combinations of breaks/potholes levels and frequencies per 1.6 km on damage to goods. The effect of truck suspensions (i.e., air and steel) is also investigated. The breaks were modeled as a

**Fig. 6.15** Damage induced by different levels and counts of breaks

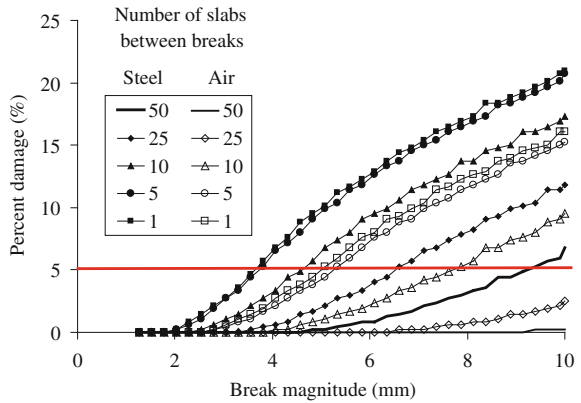

step function of variable amplitude and a length of 0.9 m. Figure 6.15 shows the increase in percent of damaged boxes as a function of break magnitude. As expected, more breaks in the roads will cause more damage to the cargo. Also, vehicles with air suspension cause less damage than those with steel spring suspension for apples. The difference in damage between steel and air suspensions is significant. Since the road isolation ability of air ride suspensions is higher than leaf spring suspensions, they will absorb more energy induced by the vertically accelerated wheel, allowing the frame and body to ride undisturbed while the wheels follow the bumps/depression in the road. This difference becomes less significant as the number of breaks increases.

**Effect of Curling on Damage to Goods**

The third case study examines the effect of different combinations of curling magnitude and frequencies for 1.6 km of concrete pavements on damage to goods. Curling is modeled as an ellipsoid of variable amplitude and width. The curling width is assumed as any value between 3 m (minimum) and slab length (maximum). Figure 6.16 shows damage as a function of curling magnitude. As expected, higher magnitudes and more curling in the roads will cause more damage to the cargo. Vehicles with air suspension cause even less damage for apples than those with steel spring suspension as compared to breaks. The difference in damage between steel and air suspensions is very significant. This difference becomes less significant as the number of curling increases.

**Effect of Interaction Between Roughness Features Magnitude, Frequencies and Trip Length on Damage to Goods**

For all previous case studies, the trip length was assumed constant and equal to the typical value in the US, i.e., 2,400 km. However, trip length ranges from 160 km

**Fig. 6.16** Damage induced by different levels and counts of curling

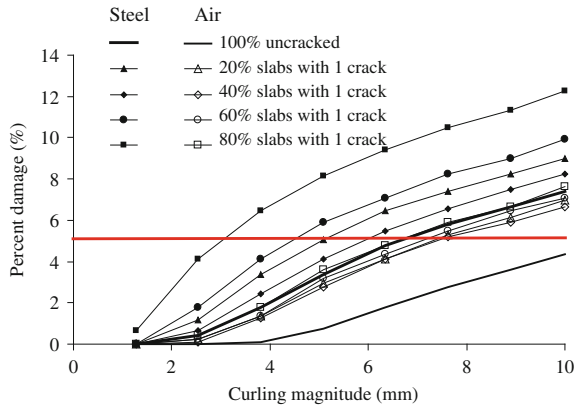

(local trip) to 2,400 km (Shipping from California). The fourth case study examines the effect of different combinations of roughness features magnitude and frequency for different trip lengths of concrete pavements on damage to goods. Figures 6.17 and 6.18 show the results for faulting and breaks.

### 6.3 Case Studies

This section shows examples on how the VOC models will be used in practice. Three different examples are presented for: (1) deterministic analysis, (2) project level analysis, and (3) network level analysis. The software developed by Chatti and Zaabar (2012) was used to generate the results presented below. For network analysis, data for traffic, environmental and pavement conditions (IRI, MPD and pavement type) is the input to the module. For project analysis, the surface profile is input to the module.

#### 6.3.1 Deterministic Analysis

In this example, the sensitivity of the total VOC to pavement conditions (IRI and texture) at 56, 89 and 112 km/h (35, 55 and 70 mph) is investigated.

##### 6.3.1.1 Effect of Roughness on VOC

The effect of pavement roughness (IRI) on VOC is estimated for all vehicle classes. Figures 6.19, 6.20 and 6.21 show examples of fuel, tire and repair and maintenance costs expressed in cents (¢) per kilometer. Table 6.33 presents examples of total



**Fig. 6.17** Damage induced by different fault magnitude and trip length. **a** 50 % of slabs are faulted, **b** 100 % of slabs are faulted

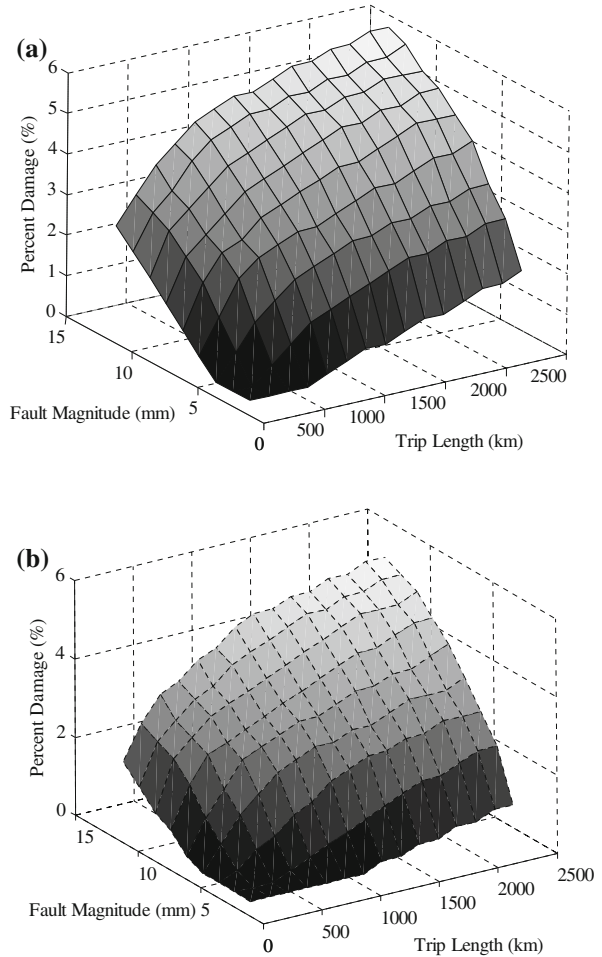

cost expressed in cents (¢) per kilometer. The figures and the table were generated at 17 °C (62.6 °F), with MPD of 1 mm (0.04 in.) and grade of 0 %.

**6.3.1.2 Effect of Texture on VOC**

The effect of pavement surface texture (MPD) on VOC is investigated for all vehicle classes. Table 6.34 presents examples of total cost expressed in cents (¢) per kilometer.

**Fig. 6.18** Damage induced by different break magnitude and trip length. **a** One break per 1.6 km, **b** three breaks per 1.6 km

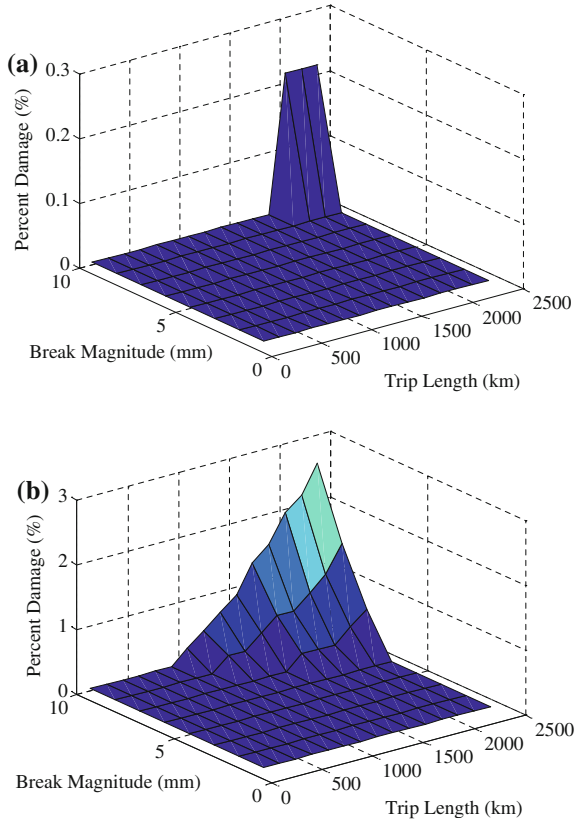

### 6.3.1.3 Discussion

The combined effect of MPD and IRI can be predicted by multiplying the roughness and texture factors. For example, if one would like to estimate the total VOC for IRI = 3 m/km (190 in./mile) and MPD = 2 mm, for an articulated truck at 88 km/h (55 mph), divide 57.2 by 56.5 from Table 6.34 (i.e., the table describes the effect of changing texture, holding IRI constant at 1 m/km), then multiply this ratio by 57.9 from Table 6.33. The cost obtained for these conditions is 58.6 cents/km (94 cents/mile).

### 6.3.2 Project Level Analysis

This example uses the mechanistic-based approach developed by Chatti and Zaabar (2012) to calculate the vehicle operating costs (fuel consumption, tire wear and repair and maintenance) for a 7.2 km long rigid pavement section on I-69 near

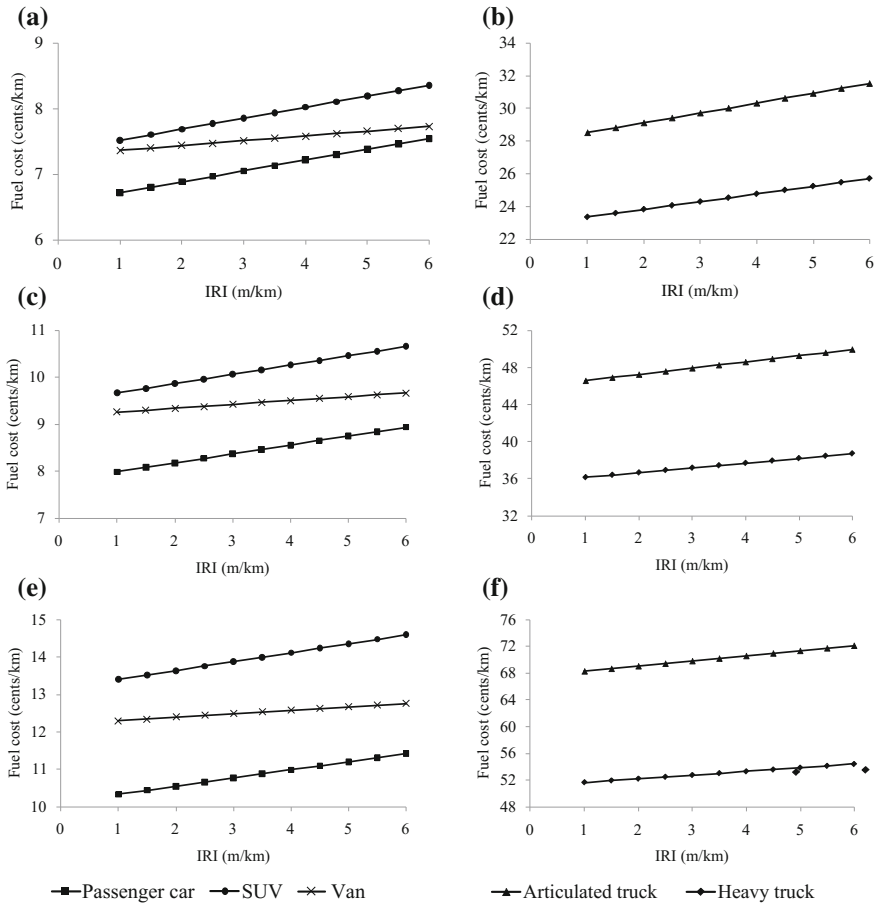
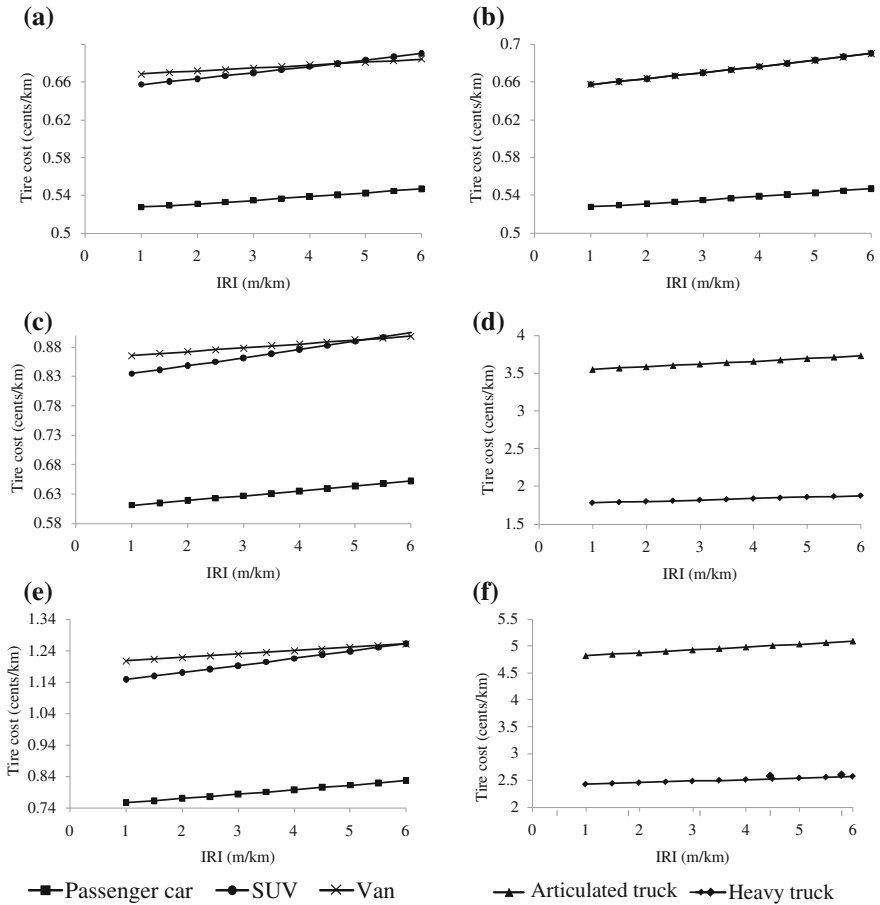

**Fig. 6.19** Effect of roughness on fuel costs. **a** Light vehicles at 56 km/h (35 mph), **b** trucks at 56 km/h (35 mph), **c** light vehicles at 88 km/h (55 mph), **d** trucks at 88 km/h (55 mph), **e** light vehicles at 112 km/h (70 mph), **f** Trucks at 112 km/h (70 mph)

Lansing, MI. The Average Daily Traffic (ADT) for this section is 29,145 in both directions, with 60 % passenger cars, 15 % commercial trucks, 10 % heavy trucks, 7 % SUV, 4 % vans, 2 % light trucks, and 2 % buses.

The pavement surface condition data were collected by the Michigan Department of Transportation (MDOT) using a Rapid Travel Profilometer and a Pavement Friction Tester. The grade was measured using a high precision GPS. Figure 6.22 shows the raw profile of the section. Figure 6.23 summarizes the distributions of its pavement conditions. The following procedure was followed to calculate VOC:

- For repair and maintenance costs, the profile was input to the computer program developed as part of this study. The software calculated the accumulated



**Fig. 6.20** Effect of roughness on tire costs. **a** Light vehicles at 56 km/h (35 mph), **b** trucks at 56 km/h (35 mph), **c** light vehicles at 88 km/h (55 mph), **d** trucks at 88 km/h (55 mph), **e** light vehicles at 112 km/h (70 mph), **f** Trucks at 112 km/h (70 mph)

damage in the suspension system which was translated into repair and maintenance costs.

- For fuel consumption and tire wear, the raw profile was divided into 0.16 km long (0.1 mile) subsections, and the IRI values were computed for each subsection. The other pavement conditions (grade, texture depth, and curvature) were input to the calibrated HDM 4 models (described in Chaps. 3 and 4) to estimate fuel consumption and tire wear.
- The total costs were calculated according to the proportion of vehicle class mentioned above, and assuming average environmental conditions (Temperature = 17 °C (62.6 °F)).

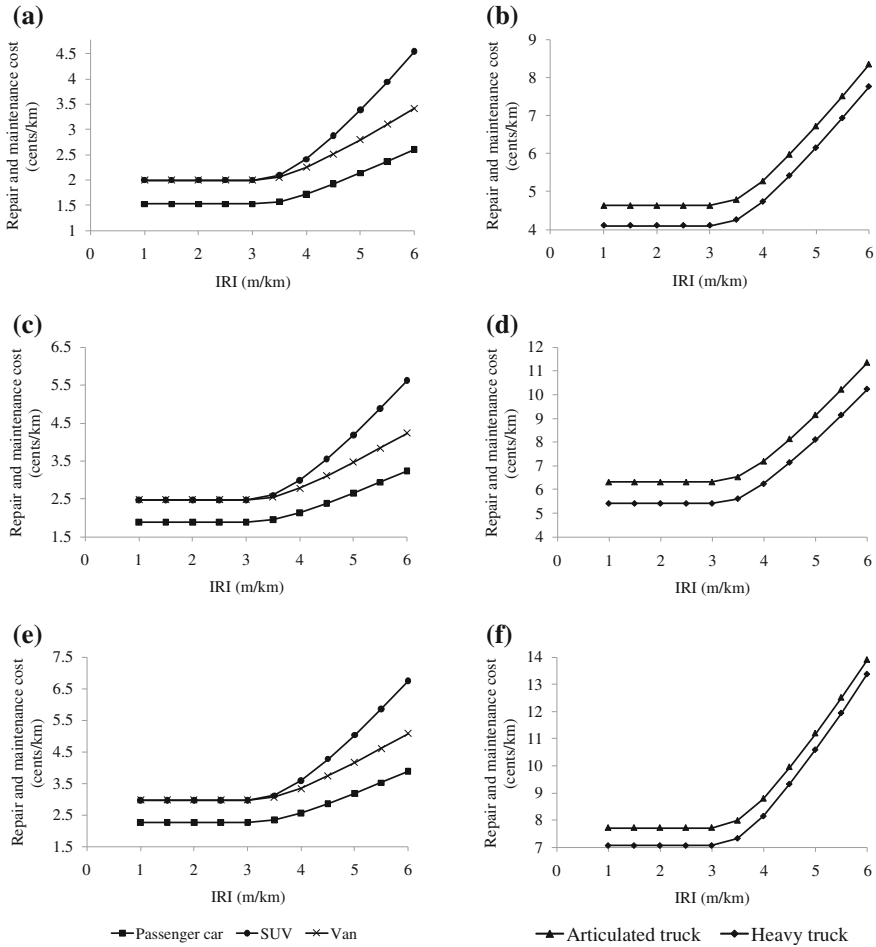

**Fig. 6.21** Effect of roughness on repair and maintenance costs. **a** Light vehicles at 56 km/h (35 mph), **b** trucks at 56 km/h (35 mph), **c** light vehicles at 88 km/h (55 mph), **d** trucks at 88 km/h (55 mph), **e** light vehicles at 112 km/h (70 mph), **f** Trucks at 112 km/h (70 mph)

Figure 6.24 shows the costs for each subsection (0.16 km or 0.1 mile) for the traffic distribution generated at 96 km/h (60 mph) for trucks and buses and at 112 km/h (70 mph) for passenger cars, vans and SUVs. Each point represents a subsection.

To estimate the reduction in VOC from rehabilitating the I-69 project, a raw profile of a newly overlaid pavement with an average IRI of 1 m/km (63.4 in./mile) was simulated. The generated road profile is shown in Fig. 6.25. It was assumed that the grade and texture distribution were not affected by the rehabilitation.

**Table 6.33** Effect of roughness on vehicle operating costs

Speed	Vehicle class	Total vehicle operating costs per vehicle (¢/km)										
		IRI (m/km)	1	1.5	2	2.5	3	3.5	4	4.5	5	5.5
56 (km/h) or 35 (mph)	PC	8.8	8.9	8.9	9.0	9.1	9.2	9.5	9.8	10.1	10.4	10.7
	Van	10.0	10.1	10.1	10.1	10.2	10.3	10.5	10.8	11.1	11.5	11.8
	SUV	10.2	10.3	10.3	10.4	10.5	10.7	11.1	11.7	12.3	12.9	13.6
	LT	15.0	15.1	15.1	15.2	15.3	15.5	15.9	16.4	17.0	17.6	18.2
	HT	28.8	29.1	29.3	29.6	29.8	30.2	30.9	31.8	32.8	33.8	34.9
	AT	35.9	36.2	36.5	36.9	37.2	37.6	38.4	39.5	40.5	41.6	42.8
89 (km/h) or 55 (mph)	PC	10.5	10.6	10.7	10.8	10.9	11.0	11.3	11.7	12.0	12.4	12.8
	Van	12.6	12.6	12.7	12.7	12.8	12.9	13.2	13.5	13.9	14.4	14.8
	SUV	13.0	13.1	13.2	13.3	13.4	13.6	14.1	14.8	15.5	16.3	17.2
	LT	21.8	21.9	22.0	22.0	22.1	22.3	22.9	23.6	24.4	25.2	26.1
	HT	43.3	43.6	43.8	44.1	44.4	44.8	45.7	46.9	48.1	49.4	50.8
	AT	56.5	56.8	57.2	57.5	57.9	58.4	59.5	60.8	62.1	63.6	65.1
112 (km/h) or 70 (mph)	PC	13.4	13.5	13.6	13.7	13.8	14.0	14.3	14.8	15.2	15.6	16.1
	Van	16.5	16.5	16.6	16.6	16.7	16.8	17.2	17.6	18.1	18.6	19.1
	SUV	17.5	17.6	17.8	17.9	18.0	18.3	18.9	19.7	20.6	21.6	22.6
	LT	30.3	30.4	30.5	30.6	30.7	31.0	31.6	32.5	33.4	34.4	35.5
	HT	61.1	61.4	61.7	62.0	62.3	62.9	64.0	65.4	67.0	68.7	70.4
	AT	80.9	81.3	81.7	82.1	82.5	83.2	84.4	85.9	87.6	89.3	91.1

1 km = 0.62 mile; 1 mm = 0.039 in; 1 m/km = 63.4 in./mile; MPD = 1 mm, Grade = 0 %; Temperature = 17 °C (62.6 °F)

**Table 6.34** Effect of texture on vehicle operating costs

Speed	Vehicle class	Total vehicle operating cost per vehicle (¢/km)										
		Mean profile depth (mm)										
		1	1.5	2	2.5	3	3.5	4	4.5	5	5.5	6
56 (km/h) or 35 mph	PC	8.8	8.8	8.8	8.8	8.8	8.9	8.9	8.9	8.9	8.9	8.9
	Van	10.0	10.1	10.1	10.1	10.2	10.2	10.3	10.3	10.3	10.3	10.4
	SUV	10.2	10.2	10.2	10.2	10.2	10.3	10.3	10.3	10.3	10.3	10.3
	LT	15.0	15.1	15.1	15.2	15.3	15.4	15.4	15.5	15.5	15.6	15.7
	HT	28.8	29.1	29.3	29.6	29.8	30.0	30.3	30.5	30.8	31.0	31.2
	AT	35.9	36.2	36.5	36.9	37.2	37.5	37.8	38.1	38.4	38.7	39.0
89 (km/h) or 55 (mph)	PC	10.5	10.5	10.5	10.5	10.6	10.6	10.6	10.6	10.6	10.7	10.7
	Van	12.6	12.6	12.7	12.7	12.8	12.8	12.9	12.9	12.9	13.0	13.0
	SUV	13.0	13.0	13.0	13.0	13.1	13.1	13.1	13.1	13.1	13.2	13.2
	LT	21.8	21.9	22.0	22.0	22.1	22.2	22.3	22.4	22.5	22.6	22.6
	HT	43.3	43.6	43.8	44.1	44.4	44.6	44.9	45.2	45.4	45.7	46.0
	AT	56.5	56.8	57.2	57.5	57.9	58.2	58.6	58.9	59.3	59.6	60.0
112 (km/h) or 70 (mph)	PC	13.4	13.4	13.4	13.4	13.4	13.5	13.5	13.5	13.5	13.6	13.6
	Van	16.5	16.5	16.6	16.6	16.7	16.7	16.8	16.8	16.9	16.9	17.0
	SUV	17.5	17.5	17.6	17.6	17.6	17.6	17.7	17.7	17.7	17.8	17.8
	LT	30.3	30.4	30.5	30.6	30.7	30.8	30.9	31.0	31.1	31.2	31.3
	HT	61.1	61.4	61.7	62.0	62.3	62.6	62.9	63.2	63.5	63.8	64.1
	AT	80.9	81.3	81.7	82.1	82.5	82.9	83.3	83.7	84.1	84.5	84.9

1 km = 0.62 mile; 1 mm = 0.039 in; 1 m/km = 63.4 in./mile; IRI = 1 m/km, Grade = 0 %; Temperature = 17 °C (62.6 °F)

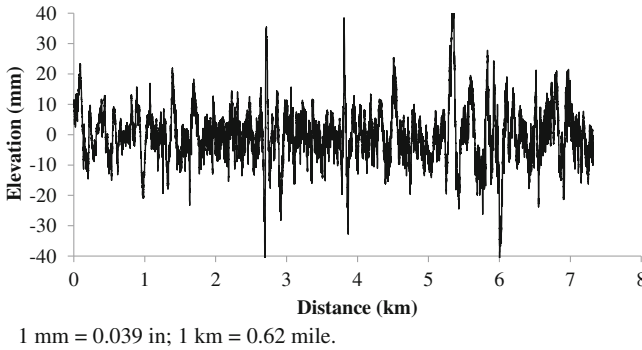

**Fig. 6.22** Raw profile of the analysis section

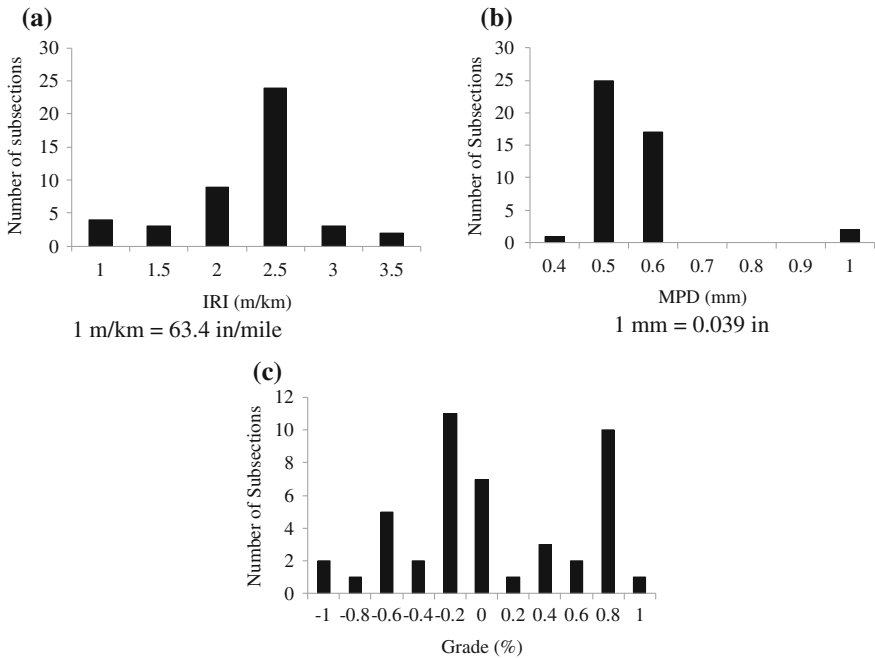

**Fig. 6.23** Pavement conditions of the analysis section. **a** IRI distribution, **b** texture distribution, **c** grade distribution

Figure 6.26 shows the reduction in VOC for each subsection. The total reduction in VOC from rehabilitating this project will be about \$2.46 million per year.

These costs could be considered in a life cycle assessment (LCA). This detailed analysis would help identify the segments of the pavement section that would result in higher operating costs. These segments would be considered for early maintenance.



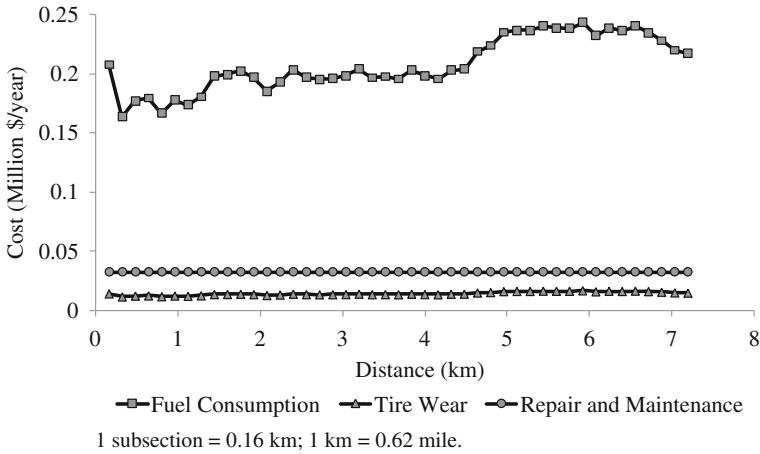

Fig. 6.24 Costs per year induced by subsection

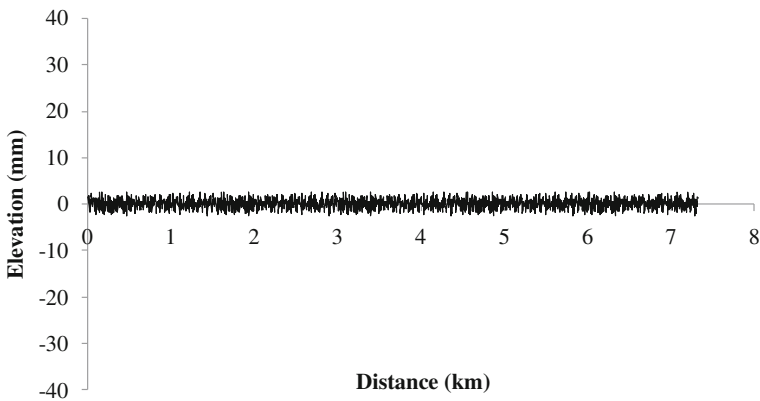
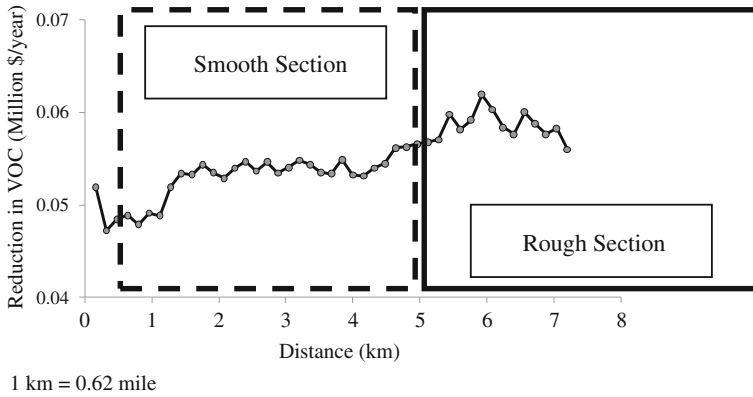

Fig. 6.25 Simulated raw profile with an average IRI of 1 m/km (63.4 in./mile)

### 6.3.3 Network Level Analysis

In this example, the models are used to compare the influence of maintaining the entire network versus maintaining a proportion of it (e.g. 50 or 90 %) for simulated pavement networks of urban interstate highways in different states. A roughness range of 1–5 m/km was assumed.

Figure 6.27 shows the assumed roughness distributions before and after rehabilitation. The distribution before rehabilitation was obtained by specifying a normal distribution with the desired IRI range. For the other two distributions, an IRI value of 1 m/km was assigned to rehabilitated sections. The remaining sections



**Fig. 6.26** Reduction in VOC from rehabilitating each section of the I-69 project

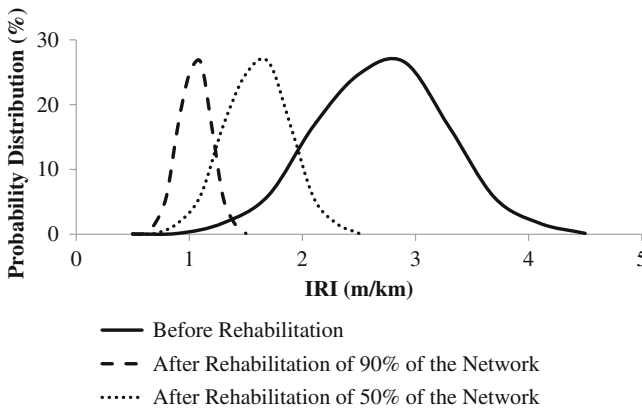

**Fig. 6.27** Assumed roughness distribution for network pavement

were then randomly assigned an IRI value from the original distribution. The Vehicle Kilometers Traveled (VKT) for each state was estimated using Table VM-3 and VM-1 from Highway Statistics (FHWA 2008). Table 6.35 shows the speed limit for trucks and cars by state used in this example (Governors Highway Safety Association 2011). Table 6.36 presents the estimated reduction in vehicle operating cost resulting from rehabilitating 50 versus 90 % of the network for each state.

According to a study conducted by the Pennsylvania Transportation Institute (Kilareski et al. 1990), 95 % of the road network in the U.S. are flat and straight (grade is 0 % and super-elevation is 0 %). Therefore, at the network level, assuming a grade of 0 % and a super-elevation of 0 % are reasonable assumptions to calculate VOC savings.

**Table 6.35** Speed limits by states

State	Urban interstates			
	Cars (km/h)	Trucks (km/h)	Cars (mph)	Trucks (mph)
Alabama	104	104	65	65
Alaska	88	88	55	55
Arizona	104	104	65	65
Arkansas	88	88	55	55
California	104	88	65	55
Colorado	104	104	65	65
Connecticut	88	88	55	55
Delaware	88	88	55	55
Dist. of Columbia	88	88	55	55
Florida	104	104	65	65
Georgia	104	104	65	65
Hawaii	80	80	50	50
Idaho	120	120	75	75
Illinois	88	88	55	55
Indiana	88	88	55	55
Iowa	88	88	55	55
Kansas	112	112	70	70
Kentucky	104	104	65	65
Louisiana	112	112	70	70
Maine	104	104	65	65
Maryland	104	104	65	65
Massachusetts	104	104	65	65
Michigan	112	96	70	60
Minnesota	104	104	65	65
Mississippi	112	112	70	70
Missouri	96	96	60	60
Montana	104	104	65	65
Nebraska	104	104	65	65
Nevada	104	104	65	65
New Hampshire	104	104	65	65
New Jersey	88	88	55	55
New Mexico	104	104	65	65
New York	88	88	55	55
North Carolina	112	112	70	70

(continued)

**Table 6.35** (continued)

State	Urban interstates			
	Cars (km/h)	Trucks (km/h)	Cars (mph)	Trucks (mph)
North Dakota	120	120	75	75
Ohio	104	104	65	65
Oklahoma	112	112	70	70
Oregon	88	88	55	55
Pennsylvania	88	88	55	55
Rhode Island	88	88	55	55
South Carolina	112	112	70	70
South Dakota	120	120	75	75
Tennessee	112	112	70	70
Texas	112	112	70	70
Utah	104	104	65	65
Vermont	88	88	55	55
Virginia	112	112	70	70
Washington	96	96	60	60
West Virginia	88	88	55	55
Wisconsin	104	104	65	65
Wyoming	96	96	60	60
U.S. Total	104	104	65	65

**Table 6.36** Estimated vehicle operating costs for different scenarios

State	Vehicle operating costs per year (\$ billions)			Reduction in VOC per year (\$ millions)	
	0 %	50 %	90 %	50 %	90 %
Alabama	2.49	2.47	2.46	25	34.9
Alaska	0.23	0.22	0.22	2.3	3.2
Arizona	2.02	2	1.99	20.2	28.3
Arkansas	1.33	1.31	1.31	13.3	18.6
California	23.42	23.18	23.09	234.3	327.5
Colorado	2.5	2.47	2.46	25	34.9
Connecticut	3.27	3.24	3.23	32.7	45.8
Delaware	0.43	0.42	0.42	4.3	6
Dist. of Columbia	0.14	0.14	0.14	1.4	2
Florida	8.41	8.32	8.29	84.1	117.6
Georgia	6.52	6.46	6.43	65.3	91.2
Hawaii	0.64	0.63	0.63	6.4	8.9
Idaho	0.43	0.42	0.42	4.3	6

(continued)

**Table 6.36** (continued)

State	Vehicle operating costs per year (\$ billions)			Reduction in VOC per year (\$ millions)	
	0 %	50 %	90 %	50 %	90 %
Illinois	7.66	7.58	7.55	76.6	107.1
Indiana	3.25	3.22	3.21	32.5	45.5
Iowa	0.87	0.86	0.85	8.7	12.1
Kansas	1.26	1.25	1.24	12.6	17.6
Kentucky	2.06	2.04	2.03	20.6	28.9
Louisiana	2.45	2.43	2.42	24.5	34.3
Maine	0.27	0.27	0.27	2.7	3.8
Maryland	4.51	4.47	4.45	45.2	63.1
Massachusetts	5.14	5.09	5.07	51.4	71.9
Michigan	5.24	5.19	5.16	52.4	73.2
Minnesota	2.9	2.87	2.86	29	40.6
Mississippi	1.19	1.18	1.17	11.9	16.6
Missouri	4.17	4.13	4.11	41.7	58.3
Montana	0.12	0.12	0.12	1.2	1.6
Nebraska	0.46	0.46	0.46	4.6	6.5
Nevada	1.19	1.17	1.17	11.9	16.6
New Hampshire	0.53	0.53	0.52	5.3	7.4
New Jersey	4.67	4.63	4.61	46.8	65.3
New Mexico	0.91	0.9	0.9	9.1	12.7
New York	7	6.93	6.9	70.1	97.9
North Carolina	4.77	4.72	4.7	47.7	66.7
North Dakota	0.13	0.13	0.13	1.3	1.8
Ohio	7.66	7.58	7.55	76.6	107.1
Oklahoma	1.59	1.57	1.56	15.9	22.2
Oregon	1.5	1.48	1.48	15	21
Pennsylvania	5.05	5	4.98	50.5	70.7
Rhode Island	0.59	0.59	0.58	5.9	8.3
South Carolina	2.06	2.04	2.03	20.6	28.8
South Dakota	0.21	0.21	0.21	2.1	2.9
Tennessee	3.9	3.86	3.84	39	54.5
Texas	13.48	13.34	13.29	134.9	188.5
Utah	2	1.98	1.97	20	27.9
Vermont	0.13	0.13	0.12	1.3	1.8
Virginia	5.13	5.08	5.06	51.4	71.8
Washington	3.65	3.61	3.59	36.5	51
West Virginia	1.06	1.05	1.04	10.6	14.8
Wisconsin	1.76	1.74	1.74	17.6	24.6
Wyoming	0.16	0.16	0.16	1.6	2.2
U.S. Total	162.47	160.85	160.2	1625.6	2272

## 6.4 Emerging Technologies and Their Effect on Vehicle Operating Costs

In recent years, growing world population and the increased demand for road transportation (with its associated energy requirements that are primarily derived from non-renewable fuels) has led to the consideration, design, and development of energy efficient vehicles and processes. To realize improvements in energy efficiency (with respect to road transportation), various engineering processes and/or technologies have been developed. Among these are: drag reducing vehicle designs, intelligent vehicle operating technologies (e.g., cruise control), use of alternative energy sources (e.g., electricity), and intelligent transportation systems that facilitate wireless communication between vehicles and transport infrastructure. These and other technological innovations help reduce vehicle operating costs (VOC) and energy consumption as well as carbon footprints. An overview of these technologies is provided in Appendix D. While emerging vehicle technologies can play a major role in reducing VOC and reducing environmental impacts, their impact on the effect of pavement conditions on VOC may not be as substantial. This section discusses the potential impact of such emerging vehicle technologies on the effect of pavement conditions on VOC. Few definitive conclusions could be reached about the effect of pavement conditions on VOC for emerging technologies.

### 6.4.1 Discussion

Mechanistic models are theoretically formulated to consider the main physical parameters and apply basic laws of physics/mechanics. By introducing a calibration factor in these models, the effect of emerging vehicle technologies on VOCs can be predicted. The following types of emerging technologies were investigated in this section:

1. Engine and combustion technologies to improve the engine efficiency of vehicles. These include engine friction reduction, gasoline direct injection, engine downsizing, variable valve actuation, cylinder deactivation, variable compression ratio, homogeneous charge compression ignition, integrated starter/generator systems, continuously variable transmission, automated manual transmission, and six+ speed gearboxes;
2. Alternative fuels and technologies. These include vehicles powered by natural gas, vehicles powered by electricity, hydrogen, biodiesel or ethanol, and hybrid vehicles;
3. Vehicle design. These include regenerative braking systems, electric motor drive/assist, lightweight materials, reducing vehicle aerodynamics, and intelligent transportation systems;
4. Automatic gear shift for heavy trucks; and,
5. Tire technologies. These include tire pressure monitoring systems, tire inner liners, use of nitrogen for filling tires, and low rolling resistance tires.

### 6.4.1.1 New Engine Technology

The change in fuel consumption as a function of change in roughness is calculated using Eqs. (6.39) and (6.40):

$$\%FC_{2-1} = \frac{FC_2 - FC_1}{FC_1} \quad (6.39)$$

$$FC_i = \xi \times P_i, \quad i=1 \text{ or } 2 \quad (6.40)$$

where:

- $\%FC_{2-1}$  Percent change in fuel consumption as a function of change in IRI
- $FC_i$  Fuel consumption due to roughness  $IRI_i$
- $\xi$  Fuel-to-power efficiency
- $P_i$  The total power required, (tractive power caused by  $IRI_i$ , engine drag, and vehicle accessories)

Because new engine technology will have a better engine efficiency, the same power will be delivered for lower fuel consumption. Therefore, percent change in power is a constant for a given roughness change if we assume that the fuel-to-power efficiency is not affected by roughness. By substituting new and old efficiency in Eq. (6.41), we obtain:

$$\%FC_{2-1}^{old} = \frac{\xi^{old} \times (P_2 - P_1)}{\xi^{old} \times P_1} = \frac{(P_2 - P_1)}{P_1} = \frac{\xi^{new} \times (P_2 - P_1)}{\xi^{new} \times P_1} = \%FC_{2-1}^{new} \quad (6.41)$$

Therefore, assuming that the efficiency is not affected by roughness, the new technology will affect only the absolute value of fuel consumption but it will have no effect on the contribution of roughness on fuel consumption. However, some of the hardware involved with new technologies might be sensitive to vehicle vibration that would require more maintenance under rougher roads than current technologies. In any case, it is likely that the effect of vibrations on the efficiency is secondary. The following savings in the fuel efficiency were reported:

1. Engine and combustion technologies (DoE 2010):
  - Gasoline direct injection will increase engine efficiency by up to 12 %.
  - Engine downsizing and cylinder deactivation will both increase engine efficiency by up to 7.5 %.
  - Variable valve actuation has the potential of increasing engine efficiency of up to 5 %.
  - Continuously variable and automated manual transmissions increases the engine efficiency by up to 6 and 7 %, respectively.
2. Alternative fuels and technologies: Fig. 6.28 shows the average fuel efficiency for passenger cars and light trucks in the United States with and without new

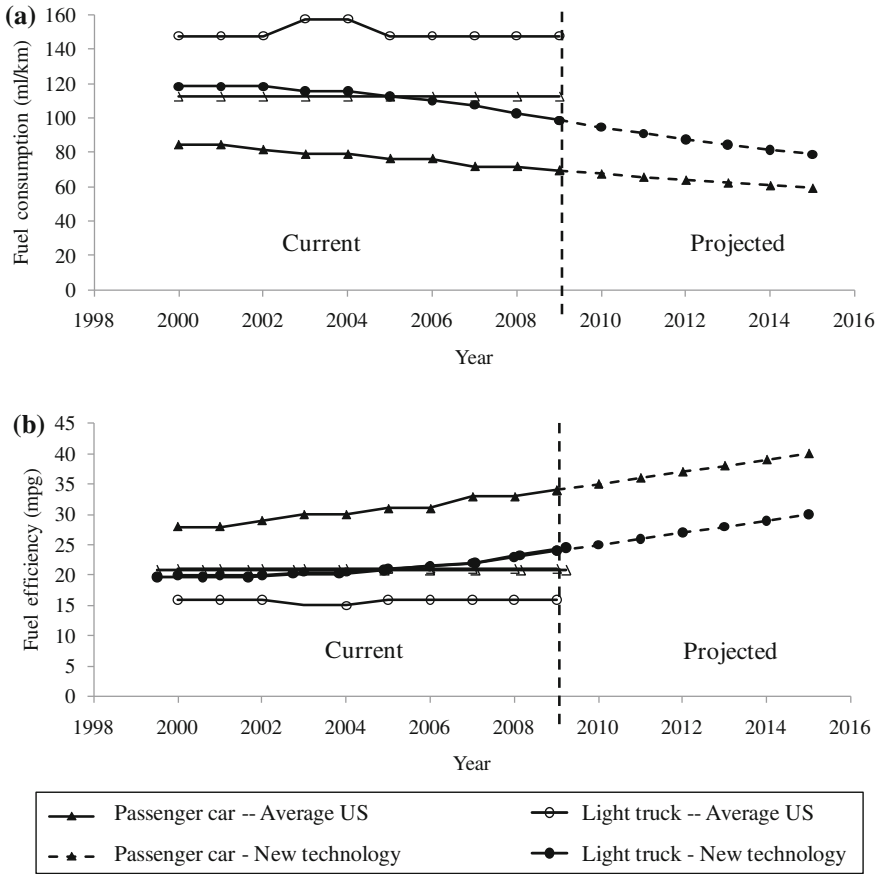

**Fig. 6.28** Current and projected average fuel consumption. **a** SI units, **b** U.S. customary units

technology (Bureau of Transportation Statistics 2010; U.S. Department of Transportation 2010), and the projected fuel efficiency from 2010 through 2015 (NHTSA 2009).

### 6.4.1.2 Vehicle Design

Vehicle manufacturers seek to minimize aerodynamics through vehicle design (smoothing vehicle shapes). In the United States, the drag coefficient has generally fallen in the current decade and vehicles have become smaller and more fuel efficient. Typical drag coefficients for current passenger cars range from 0.3 to 0.52 and is expected to range from 0.25 to 0.35 for future passenger cars (fuel economy.org 2010).



Truck Manufacturers Association and the U.S. Department of Energy conducted a two-year collaborative study to investigate a variety of design improvements that would reduce aerodynamic drag and significantly improve fuel efficiency (DoE 2006). The following technologies were identified:

- Gap enclosures that reduce aerodynamic drag in the gap between the tractor and trailer.
- Side skirts that improve aerodynamics and reduce airflow under the trailer in crosswinds.
- Side mirror designs that reconfigure shape and support systems to reduce aerodynamic drag.

When introducing all aerodynamic improvements in one vehicle, the reduction in aerodynamic drag could be as much as 23 %. Every 2 % reduction in aerodynamic drag will result in a 1 % improvement in fuel efficiency. Note, however, that these reductions in fuel consumption are believed to be little affected by pavement conditions.

#### 6.4.1.3 Automatic Gear Shift for Heavy Trucks

A study by SCANIA Inc. reported that automatic gearshift for heavy trucks could save as much as 10 % in fuel consumption (Lundstrom 2010). Note, however, that these reductions in fuel consumption are believed to be little affected by pavement conditions.

#### 6.4.1.4 New Tire Technology

Use of tires with lower rolling resistance coefficients than conventional tires will result in less fuel consumption. Equation 6.42 describes the rolling resistance model in the HDM 4 after calibration. The rolling resistance is a function of vehicle characteristics and pavement conditions.

$$Fr = CR2 \times (b11 \times Nw + CR1 \times (b12 \times M + b13 \times v^2)) \quad (6.42)$$

where:

b11–b13 A function of the wheel diameter

$$\begin{cases} b11 = 37 * WD \\ b12 = 0.064/WD \\ b13 = 0.012 * Nw/WD^2 \end{cases}$$

WD Wheel diameter in mm

Nw Number of wheels

M Mass of the vehicle in Kg

**Table 6.37** Calibration factor for rolling resistance force

Vehicle class	Kcr2
Medium car	0.5
SUV	0.58
Light truck	0.99
Van	0.67
Articulated truck	1.1

- $v$  Vehicle velocity in m/s
- CR1 Rolling resistance tire factor  
1.3 for cross-ply bias  
1.0 for radial
- CR2 Rolling resistance surface factor  
 $Kcr2[a0 + a1 * Tdsp + a2 * IRI + a3 * DEF]$
- Kcr2 Calibration factor (Table 6.37)
- Tdsp Texture depth from the sand patch method in mm  $1.02 \times MPD + 0.28$
- MDP Mean Profile Depth
- DEF Benkelman Beam rebound deflection in mm
- IRI International Roughness Index in m/km
- a0–a3 Model coefficient (function of the vehicle mass, surface class and type) (Table 6.38)

The effect of new tire technology on fuel and tire consumption could be accommodated by modifying some of the tire related variables in HDM 4 such as b11 through b13 and CR1. Alternatively, one could conduct limited field tests (e.g., coast down test) to estimate the new parameters a0–a3 for CR2. Finally, the coefficients  $C_{orc}$  and/or  $C_{irc}$  could be affected by new tire technologies. If one were to update these coefficients, a new calibration study would need to be conducted.

### 6.4.2 Summary

The growing demand for fuel efficient vehicles has accelerated the R&D efforts dealing with the use of alternative fuels in vehicle propulsion, combustion and propulsion processes, environmental issues, aerodynamic/pavement friction efficiency, and congestion impacts. The technologies presented in this section have the

**Table 6.38** Parameters for CR2 model with conventional tires

Surface class	<=2,500 kg				>2,500 kg			
	a0	a1	a2	a3	a0	a1	a2	a3
Asphalt	0.9	0.022	0.022	0	0.84	0.03	0.03	1.34
Concrete	0.9	0.022	0.022	0	0.84	0.03	0.03	0

potential of lowering VOC. The majority of current R&D efforts which focus on engine and combustion technologies (including alternative fuels) have the potential for significantly reducing energy loss from vehicle operation. The cost of retrofitting existing fleets and the expected decreasing cost of these vehicles will determine the validity of the predicted VOC savings.

In summary, new technologies dealing with engine and combustion, alternative fuels, vehicle design and maintenance, and tires will affect vehicle operating costs. The effect of pavement conditions on VOCs will also be influenced by some of these technologies, specifically:

1. **New Engine Technology:** The HDM 4 model could be updated by changing the engine efficiency of vehicle to take into account these technologies. It was reported in this study that new engine technologies will increase the engine efficiency by 5–12 %. It was also concluded that the effect of roughness on fuel consumption would likely to be unaffected by these technologies.
2. **Vehicle Design:** The HDM 4 model could be updated by changing the aerodynamic characteristics of vehicle to take into account these technologies. It was reported in this study that, when introducing all aerodynamic improvements in one vehicle, the reduction in aerodynamic drag could be as much as 23 %. Every 2 % reduction in aerodynamic drag will result in a 1 % improvement in fuel efficiency. Note, however, that these reductions in fuel consumption are believed to be little affected by pavement conditions.
3. **Automatic Gear Shift for Heavy Trucks** could save as much as 10 % in fuel consumption. Note, however, that these reductions in fuel consumption are believed to be little affected by pavement conditions.
4. **New Tire Technology:** The effect of new tire technology on fuel and tire consumption could be accommodated by modifying some of the tire related variables in HDM 4 such as b11 through b13 and CR1. Alternatively, one could conduct limited field tests (e.g., coast down test) to estimate the new parameters a0–a3 for CR2.

In addition, even though the new technologies will make vehicles more fuel efficient, the expenses of these technologies relative to current vehicles will be higher. Some of the hardware involved with new technologies might be sensitive to vehicle vibration that would require more maintenance under rougher roads than current technologies. On the other hand, newer technologies in suspension systems, axle designs, etc. could lead to less frequent maintenance. In either case, the mechanistic-empirical approach for repair and maintenance costs adopted by Chatti and Zaabar (2012) could offer a methodology to investigate this issue in the future.

## 6.5 Summary and Conclusions

The effects of pavement conditions on Vehicle Operating Costs (VOC) are essential to sound planning and management of highway investments, especially under

increasing infrastructure demands and declining budget resources. The recommended models reflect current vehicle technologies in the United States. The chapter focused only on the cost components that are mostly affected by pavement conditions, namely, fuel consumption, repair and maintenance costs and tire wear.

This chapter demonstrated that vehicle operating costs increase with pavement roughness across all classes of vehicles and types of pavements investigated. The most important cost components affected by roughness are fuel consumption followed by repair and maintenance, then tire wear.

### ***6.5.1 Fuel Consumption***

Among pavement conditions (other than grade and curvature), the most important factors are surface roughness (IRI), followed by pavement type and surface texture (MPD), which play a secondary effect that is observed only at lower speed:

An increase in IRI of 1 m/km (63.4 in./mile) will increase the fuel consumption of passenger cars by about 2 % irrespective of speed. For heavy trucks, this increase is about 1 % at normal highway speed (96 km/h or 60 mph) and about 2 % at low speed (56 km/h or 35 mph).

Surface texture (MPD) has no effect on fuel consumption for all vehicle classes with the exception of heavy trucks. An increase in MPD of 1 mm will increase fuel consumption by about 1.5 % at 88 km/h (55 mph) and about 2 % at 56 km/h (35 mph).

Pavement type has no effect on fuel consumption for all vehicle classes with the exception of heavy trucks. Heavy trucks driven over AC pavements will consume about 4 % more fuel than over PCC pavement at 56 km/h (35mph) in summer conditions. The effect of pavement type was statistically not significant at higher speeds. No data was available for heavy trucks in winter.

### ***6.5.2 Repair and Maintenance***

There is no effect of roughness up to IRI of 3 m/km. Beyond this range, an increase in IRI up to 4 m/km will increase R&M cost by 10 % for passenger cars and heavy trucks. At IRI of 5 m/km, this increase is up to 40 % for passenger cars and 50 % for heavy trucks.

### 6.5.3 Tire Wear

Only the effect of roughness was considered. An increase in IRI of 1 m/km (63.4 in./mile) will increase the tire wear of passenger cars and heavy trucks by 1 % at 88 km/h (55 mph).

### 6.5.4 Damage to Goods

A novel approach was proposed to estimate the damage induced to transported goods by roughness features. The proposed approach uses a mechanistic-empirical method to conduct product fragility assessment using numerical modeling of vehicle and product vibration response. A half-truck model was used to simulate vehicle vibrations. The principle of conservation of momentum (inelastic shocks) was used to estimate damage to goods. The analysis of three case studies for horticultural produce showed that:

- Air suspensions cause less damage to the transported goods than steel suspensions.
- Shorter spacing between faults in jointed concrete pavements will cause less damage to the transported goods in trucks with steel suspension.
- Low speed will cause more damage to transported goods in trucks with steel suspensions than higher speed.
- More breaks on the road will cause more damage to the transported goods.

The approaches reported in this chapter could help in better estimating vehicle operating costs at the project and network levels. For routine application, a highway agency would need to run a given profile (for a given project) through the program developed in this study.

## References

- Barnes, G., & Langworthy, P. (2004). Per mile costs of operating automobiles and trucks. *Transportation Research Record, 1864*, 71–77.
- Becker, M. A. (1972). Selection of optimal investment strategies for low volume roads (MS dissertation, Department of Civil Engineering, Massachusetts Institute of Technology, June 1972).
- Bein, P. (1993). VOC model needs of a highways department. *Road and Transport Research, 2*, 40.
- Bennett, C. R. (1989). *The New Zealand vehicle operating cost model, RRU Bulletin B2*. Wellington: Transit New Zealand.
- Bennett, C. R., & Greenwood, I. D. (2003), Volume 7: Modeling road user and environmental effects in HDM-4, Version 3.0, international study of highway development and management tools (ISOHDM), World Road Association (PIARC). ISBN: 2-84060-103-6.
- Berthelot, C. F., Sparks, G. A., Blomme, T., Kajner, L., & Nickeson, M. (1996). Mechanistic-probabilistic vehicle operating cost model. *Journal of Transportation Engineering, 122*(5), 337–341.

- Bester, C. J. (1981). Fuel consumption of highway traffic (Ph.D. dissertation, University of Pretoria, South Africa).
- Biggs, D. C. (1987). Estimating fuel consumption of light to heavy vehicles, ARRB internal report AIR 454-1, Australian Road Research Board, Nunawading.
- Biggs, D. C. (1988). ARFCOM—Models for estimating light to heavy vehicle fuel consumption, research report ARR 152, Australian Road Research Board, Nunawading.
- British Department of Transportation. (1993). *COBA user's manual*. UK: Department of Transport.
- Bureau of Transportation Statistics. (2010). Highway statistics, Washington, D.C.: Annual Issues, Table VM-1.
- Cebon, D. (1999). *Handbook of vehicle-road interaction*. Lisse, Netherlands: Swets & Zeitlinger.
- Chatti, K. & Zaabar, I. (2012). Estimating the effects of pavement condition on vehicle operating costs, report 720, national cooperative highway research program, Transportation Research Board.
- Chesher, A., & Harrison, R. (1987). *Vehicle operating cost: evidence from developing countries*. Washington, D.C.: World Bank Publications.
- Chesson, J. H., & O'Brien, M. (1971). Analysis of mechanical vibration of fruit during transportation". *Transactions of ASAE*, 69–628.
- Claffey, P. J. (1971). Running cost of motor vehicles as affected by road design and traffic, NCHRP report No. 111, national cooperative highway research program, Transportation Research Board, Washington, DC, United States, 1971.
- du Plessis, H. W. (1989). *An investigation of vehicle operating cost relationships for use in South Africa, road roughness effects on vehicle operating costs—Southern Africa relations for use in economic analyses and road management systems*. Pretoria: CSIR.
- Federal Highway Administration. (2008). Highway statistics, US department of Transportation. <http://www.fhwa.dot.gov/policy/ohpi/hss/index.htm>.
- Governors Highway Safety Association. (2011). Retrieved May 2011, from <http://www.motorists.org/speed-limits/state-chart>.
- Hammarström, U., & Karlsson, B. (1991). VETO a computer program for calculating transport costs as a function of road standard. English translation of VTI Report 501. Linköping: Swedish Road and Traffic Institute.
- Hammarström, U., & Henrikson, P. (1994). Reparationskostnader för bilar Kalibrering av Varldsbankens HDM-3-samband för svenska förhallanden. VTI Meddelande Nr. 743. Linköping: Swedish Road and Traffic Institute.
- Harrison, R., & Aziz, S. (1998). *HDM 4 Tyre relationships*. Memorandum to ISOHDM Secretariat: Center for Transportation Research, the University of Texas at Austin, USA.
- Hendrickson, J. (2004). *Energy use in the U.S. food system: A summary of existing research and analysis*. UW-Madison: Center for Integrated Agricultural Systems. <http://www.cias.wisc.edu/wp-content/uploads/2008/07/energyuse.pdf>.
- Henry, J. J. (2000). *NCHRP synthesis 291: Evaluation of pavement friction characteristics*. Washington, D.C.: Transportation Research Board, National Research Council.
- Jones, C. S., Holt, J. E., & Schoorl, D. (1991). A model to predict damage to horticultural produce during transport. *Journal of Agriculture Engineering Research*, 50, 259–272.
- Kilareski, W. P., Mason, J. M., Gittings, G. L., Antle, C. E., Wambold, J. C., & et al. (1990). U.S. A. road surface and use characteristics catalog, prepared for chrysler motors corporation, The Chrysler Challenge Fund, Pennsylvania Transportation Institute, PTI 9018, April 1990.
- Klaubert, E. C. (2001). Highway effects on vehicle performance, FHWA-RD-00-164, U.S. Department of Transportation, Federal Highway Administration, Washington D.C, 2001.
- Lundstrom, A. (2010). The challenges for heavy vehicles. Presentation at the *11th International Symposium on Heavy Vehicle Weights and Dimensions, Melbourne, Australia*, 14–17 March 2010.
- McFarland, William F., Memmott, Jeffrey L., & Chui, Margaret L. (1993). *Microcomputer evaluation of highway user benefits, NCHRP Project 7–12, College Station*. TX: Texas Transportation Institute.

- National Association of Australian State Road Authorities. (1978). A study of the operation of large combination vehicles (road trains), working party report No. I, National Association of Australian State Road Authorities.
- National Highway Traffic Safety Administration. (2009). 49 CFR Parts 531 and 533 Docket No. NHTSA-2009-0042. [http://www.nhtsa.gov/DOT/NHTSA/Rulemaking/Rules/Associated%20Files/CAFE\\_MY2020\\_ProductPlanInfoReq.pdf](http://www.nhtsa.gov/DOT/NHTSA/Rulemaking/Rules/Associated%20Files/CAFE_MY2020_ProductPlanInfoReq.pdf).
- Papagiannakis, T. (2000). Methodology to improve pavement-investment decisions. NCHRP project 1-33, NCHRP.
- Poelman, M. A., & Weir, R. P. (1992). Vehicle damage induced by road surface roughness. In J. J. Henry & J. C. Wambold (Eds.), *Vehicle, tire, pavement interface, ASTM STP 1164* (pp. 97–111). American Society for Testing and Materials: Philadelphia.
- Prem, H. (2000). *A road profile-based truck ride index*. Sydney: Austroads. Austroads Publication No. AP-R177/00.
- Rich, P., Van Pelt, T., Enshayan, K., & Cook, E. (2008) Food duel and freeways: An Iowa perspective on how far food travels, fuel usage and greenhouse gas emissions, June 2001:1. Leopold Center for Sustainable Agriculture, 27 February, 2008 from [http://www.leopold.iastate.edu/pubs/staff/ppp/food\\_mil.pdf](http://www.leopold.iastate.edu/pubs/staff/ppp/food_mil.pdf).
- Robson, J. D. (1979). Road surface description and vehicle response. *International Journal of Vehicle Design*, 1(1), 25–35.
- Sandberg, U., & Ejsmont, J. A. (2002). *Tyre/road noise reference book*. Kisa, Sweden: Informex. ISBN 91-631-2610-9.
- Sayers, M. W., Gillespie, T. D., & Paterson, W. D. O. (1986). Guidelines for the conduct and calibration of road roughness measurements. World Bank Technical Paper No. 46. Washington, D.C.: The World Bank.
- Sayers, M. W., & Karamihas, S. M. (1998). *The little book of profiling*. Ann Arbor: UMTRI.
- Texas Department of Agriculture. (2007). Texas agriculture packs a punch. Texas agriculture facts, go Texan program. Retrieved July 12, 2007 from [http://www.gotexan.org/gt/channel/render/items/0,1218,1670\\_1693\\_0\\_0,00.html](http://www.gotexan.org/gt/channel/render/items/0,1218,1670_1693_0_0,00.html).
- Timm, E. J., Bollen, A. F., Dela Rue, B. T., & Woodhead, I. M. (1998). Apple damage and compressive forces in bulk bins during orchard transport. *Applied Engineering Agriculture*, 14, 165–172.
- U.S. Department of Energy. (2006). Road map and technical white papers. 21st century truck partnership.
- US Department of Energy. (2010). Energy efficient technologies—engine technologies, Energy Efficiency and Renewal Energy, Washington D.C. Retrieved September 2010, from [http://www.fueleconomy.gov/feg/tech\\_engine\\_more.shtml](http://www.fueleconomy.gov/feg/tech_engine_more.shtml).
- U.S. Department of Transportation. (2010). National highway traffic safety administration, average fuel economy standards, passenger cars and light trucks, MY 2011–2015.
- Watanatada, T. (1987). Highway design and maintenance standards model (HDM) model description and user's manual—Release II. *Transportation, water and telecommunications department report*. Washington, D.C.: The World Bank.
- Watanatada, T., Harral, C. G., Paterson, W. D. O., Dhareshwar, A. M., Bhandari, A., & Tsunokawa, K. (1987). *The highway design and maintenance standards model*, Vol. 1—Description. John Hopkins University Press: The World Bank.
- Weille, D. (1966). *Quantification of Road User Savings*. Washington, DC: World Bank Staff Occasional Paper.
- Winfrey, R. (1969). *Economic analysis for highways*. Scranton, PA: International Textbook Company.
- Zaabar, I., & Chatti, K. (2010). Identification of localized roughness features and their impact on truck durability. *11th International Symposium on Heavy Vehicle Weights and Dimensions, Melbourne, Australia*, March 14–17 2010.
- Zaniewski, J. P., Butler, B. C., Cunningham, G., Elkins, G. E., Paggi, M. S., & Machemehl, R. (1982). *Vehicle operating costs, fuel consumption, and pavement type and condition factors, FHWA-PL-82-001*. Austin: Texas Research and Development Foundation.

# Chapter 7

## Permeable Pavements and Storm Water Management

Miklas Scholz

**Abstract** The purpose of this book chapter is to summarize the recent literature on permeable pavements and related systems, highlighting current trends in research and practice, and to recommend future areas of research and development. Note that permeable pavements are also known as porous and pervious pavements depending on the industry and country of origin. The development of permeable pavements using concrete pavers as an integral part of sustainable drainage systems is reviewed in the context of traditional and modern urban drainage. Emphasis is given to detailed design, maintenance and water quality control aspects. The advantages and disadvantages of different pavement surfaces are discussed with the help of recent and relevant case study findings. The latest innovations are explained, and their potential for further research work is outlined. Current research regarding the development of systems combining geothermal heating and cooling, water treatment and recycling, and pavement is promising.

### 7.1 Pavement Systems Within the Sustainable Drainage Context

Most cities of the developed world rely on under-sized below-ground pipe network systems, which have frequently been developed in the 19th century. Traditional systems capture storm runoff, and subsequently distribute it to nearby watercourses or sewer systems. Some of these systems have become ineffective, inefficient and a liability to the environment. Furthermore, they are usually very expensive (Schlüter and Jefferies 2004; Scholz 2006a, 2010). Instead of focussing on ‘end-of-pipe’ treatment, novel sustainable drainage systems challenge the traditional approach of

---

M. Scholz (✉)

Civil Engineering Research Group, School of Computing, Science and Engineering,  
The University of Salford, Newton Building, Salford M5 4WT, England, UK  
e-mail: m.scholz@salford.ac.uk



wastewater treatment by optimising the resource utilisation and development of novel and more productive technologies (Balkema et al. 2002).

Various types of permeable pavement systems are suitable for a wide variety of residential, commercial and industrial applications, yet are frequently confined to light duty and infrequent usage, even though the capabilities of these systems frequently allow for a much wider range of usage (Scholz and Grabowiecki 2007; Scholz 2013). Note that permeable pavements are also called porous or pervious pavements depending on the surface type (e.g., pavers, asphalt and concrete, respectively) and sometimes on the country of application or origin. The general types of surfaces can be classified as permeable pavers, pervious concrete, porous asphalt and concrete with drainage holes cast in them. Where there is any concern about the possible migration of pollutants into the groundwater, any permeable pavement system should be constructed with an impermeable membrane, and the treated storm water should subsequently be discharged into a suitable drainage system (Wilson et al. 2003).

## 7.2 Permeable Pavement Systems

This sub-chapter is mainly concerned with permeable pavement systems using concrete pavers in the context of storm water management. However, reference is made to other surface types if and when considered to be relevant.

Modular interlocking concrete blocks of the internal drainage cell type are pre-cast or cast-in-place lattice or castellated pavers of concrete or plastic, which contain open cells. Soil mixed with grass seeds or porous aggregates usually fill the cells. Modular interlocking concrete blocks with external open drainage cells are also available on the market. Open cells are formed when blocks are assembled in an interlocking manner and filled with clean gravel (Scholz and Grabowiecki 2007).

Sustainable drainage systems such as various types of permeable pavement systems (e.g., with interlocking concrete paver surfaces as shown in Fig. 7.1) have evolved from a growing recognition that traditional storm water management systems have limitations due to growing rates and volumes of storm water runoff, mainly caused by increased urbanization and changing weather patterns (Dierkes et al. 2002; Schlüter and Jefferies 2004).

Permeable pavement designs vary greatly. In addition to supporting traffic loads, the general principle of permeable pavement systems is simply to collect, treat and infiltrate freely any surface runoff to support groundwater recharge (CIRIA 2007). In comparison to traditional drainage systems, storm water retention and infiltration is a sustainable and cost effective process, which is suitable for urban areas (Anderson et al. 1999; Dierkes et al. 2002). Moreover, permeable pavement systems have many potential benefits such as reduction of runoff, recharging of groundwater, saving water by recycling and prevention of pollution (Pratt et al. 1999; Scholz 2013).

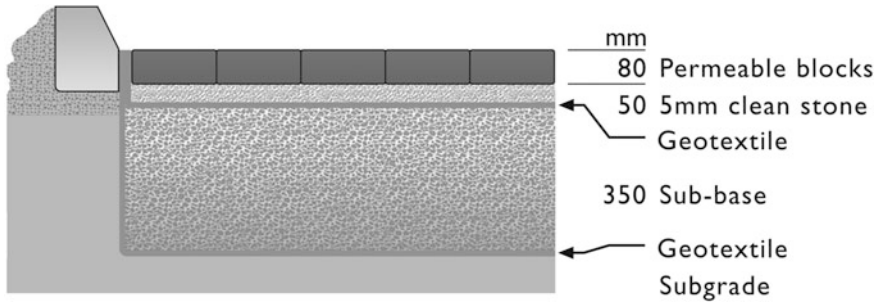

**Fig. 7.1** Layout of a permeable pavement system with concrete paver surface and permeable clean stone and sub-base (typical for the United Kingdom)

Permeable pavement systems have not only been established as a sustainable drainage solution, but also as a technology for pollutant control concerning surface runoff from areas used as roads or parking spaces, where contaminated water may infiltrate into the underlying soil. Harmful pollutants such as hydrocarbons and heavy metals in surface runoff have the potential to endanger soil and groundwater resources when they are not sufficiently biodegraded and/or removed during infiltration (Brattebo and Booth 2003; Dierkes et al. 2002).

Reductions in suspended solids, biochemical oxygen demand, chemical oxygen demand and ammonia levels in comparison to highway gullies not only demonstrate the high treatment efficiency of various permeable pavement systems, but also that there is no need for frequent maintenance, unlike with gully pots, which are collection chambers for road runoff (Pratt et al. 1999; Scholz 2010).

Moreover, hydrocarbon pollution and mineral oil deposition onto urban surfaces have been problems most effectively addressed by permeable pavements. Research has also shown that the structure itself can be used as an effective in situ aerobic bioreactor (Scholz 2006).

### 7.3 Porous Pavements and the Challenge of Clogging

Porous pavements (i.e. pavements with pores rather than a surface made up of pavers) are a more recent and special type of permeable pavement (generic terminology) system. They have also been developed to reduce the runoff rates and growing volumes of storm water collected in those urbanized areas, which become more built-up. Moreover, they should also meet storm water demands while providing a hard surface, which can be utilized in urban areas (Schlüter and Jefferies 2004; Scholz 2006).

Various new and traditional materials can be used as porous pavements; e.g., porous asphalt (or macadam pavement) looks similar to conventional asphalt, but has a higher permeability. It consists of open graded asphalt over an open graded

aggregate base located above well-draining soil. In comparison, porous concrete pavement contains aggregates and a portland cement binder over an open graded aggregate base. The porosity of the top layer is provided by the omission of fine aggregates.

Porous concrete and asphalt products can function as pollution sinks, because of their particle retention capacity during filtration. The high porosity of porous concrete leads to good infiltration and air exchange rates. Filtered out pollutants can sometimes be removed by cleaning of the pavement (Dierkes et al. 2002). Various designs and technologies including vacuum cleaners have been proposed (see Sect. 1.5).

Some of the earlier developed porous asphalt and porous concrete pavement systems are prone to clogging, usually within a few years after installation, if not properly maintained. Due to clogging of the voids, these systems can experience a loss of porosity. Clogging is usually caused by sediment being ground into the porous pavement by traffic before being washed off, waterborne sediment, which drains onto pavements and clogs pores before being washed off, and shear stress caused by numerous breaking actions of vehicles at the same spot, which results in collapsing pores (Scholz and Grabowiecki 2007).

If the porous surface is totally clogged, it has to be removed and subsequently replaced by a new layer. Frequent replacement of heavy polluted surfaces renders porous pavements impractical and expensive. However, modular interlocking concrete blocks (Fig. 7.1) are also associated with a minor risk of clogging by sediment and may produce a low quality effluent. Therefore, permeable pavement systems comprising large gaps between solid concrete pavers are usually preferred for most applications where the runoff is contaminated with a lot of solids (Scholz and Grabowiecki 2007).

## 7.4 Designs to Reduce Clogging and Improve Water Quality

This sub-chapter is only concerned with general design principles aiming at reducing the risk of clogging and improving the outflow water quality of permeable pavement systems used for storm water treatment. The treated water may be infiltrated into the ground, recycled or transferred to a nearby watercourse. For complete design manuals regarding different surface types and corresponding hydraulic guidelines for the entire systems, the reader may refer to relevant organizations located within his or her own country and research papers specifically concerned with concrete, asphalt and interlocking concrete paving; e.g., Kayhanian et al. (2012a) and Li et al. (2012) discuss guidelines used in the USA.

Permeable pavement systems used for runoff control and treatment usually comprise the following four distinct components (James and von Langsdorf 2003): Pavers and bedding layer (coarse filtration processes); unsaturated zone of the base material (volume for additional water storage during storms); saturated zone of the

base material (runoff treatment by extended storage); and subgrade (recipient of treated runoff if infiltration is allowed). In addition, various aggregates that may impact on the runoff treatment efficiency can be incorporated into permeable pavement systems. For example, Nishigaki (2000) described specially designed blocks for permeable paving using recycled melted slag. No metal leaching was detected in practice.

It is generally accepted that pavement surfaces are inert, and do not significantly contribute to permeable pavement clogging and diffuse pollution. Kayhanian et al. (2010) concludes that chemicals solely generated from pavement surface material are negligible and pollutants in road runoff are mostly related to other road and land use sources. Therefore, this sub-chapter focuses on pollutants originating from outside the pavement system.

Scanned image analysis and porosity profile of pavement systems have shown that most clogging occurs near the surface of the pavement (Kayhanian et al. 2012a). This indicates the relatively high importance of the surface (and its maintenance; see Sect. 1.5) in comparison to the corresponding subgrade. Considering the challenge of clogging as a system failure criteria, the lifespan of surfaces that let water pass through them depends predominantly on the size of the air voids in the media used for construction. Considering the reasons for structural failure of asphalt, the more possibilities for oxidation, the less durability can be achieved (Choubane et al. 1998).

Long-term studies assessing both clogging and structural failure modes in addition to water quality improvements are relatively rare. Four commercially available permeable pavement systems were evaluated by Booth and Leavitt (1999) after 6 years of daily parking usage for structural durability, ability to infiltrate precipitation, and impacts on infiltrate water quality. All pavement systems showed no major signs of wear. Virtually all rainwater infiltrated through the permeable pavement systems, with almost no surface runoff. The infiltrated water had significantly lower levels of copper and zinc than the direct surface runoff from the asphalt area. Furthermore, Roseen et al. (2012) assessed the water quality and hydrologic performance of a porous asphalt pavement as a system for runoff treatment in a cold climate. They observed exceptional water quality treatment performance for petroleum hydrocarbons, zinc, and total suspended solids.

In addition to the standard design of permeable pavements, geotextiles such as filter fabrics help to prevent clay and silt from migrating into the base of permeable pavement systems (Scholz 2013). In a permeable bituminous-stabilized base course, the presence of geotextile helps to reduce the rutting depth and rate of block breakage, maintaining a good level of pavement serviceability such as easy cleaning. A geotextile with a sufficient fiber area weight such as 60 g/m<sup>2</sup> may be applied (Omoto et al. 2002). Furthermore, most geotextiles can help to retain and degrade oil, if clogging (e. g. silting) is not a problem (Newman et al. 2004; Scholz 2006b, 2013).

Tests have shown that evaporation, drainage and retention within the permeable structures were mainly influenced by the particle size distribution of the bedding material, and by the retention of water in the surface blocks (Andersen et al. 1999; Scholz 2006a). Movement of water through the permeable pavement installation is

controlled by surface runoff, infiltration through the pavement stones, percolation through the unsaturated zone, lateral drainage at the base and deep percolation through the subgrade. There are three possible fates for precipitation reaching the surface of a permeable pavement installation (James and Langsdorf 2003; Scholz 2006b): Infiltration to subgrade; evaporation; and runoff (overland flow).

In designing a permeable pavement installation, it is fundamentally important to provide and maintain surface infiltration and storage capacity to allow an adequate volume of storm water to be captured and treated by the facility. James and von Langsdorf (2003) describe the underlying method and function of a computer program, which uses the United States Environmental Protection Agency Storm Water Management Model for the hydraulic design of permeable pavement installations.

In comparison to impermeable asphalts, tanked permeable pavement systems, which are used to store and treat runoff before release, provide more effective peak flow reductions (up to 42 %) and longer discharging times. There is also a significant reduction of evaporation and surface water splashing (Abbot and Comino-Mateos 2003; Booth and Leavitt 1999; Pagotto et al. 2000; Scholz 2006a).

## 7.5 Maintenance to Enhance Infiltration

This sub-chapter is concerned with general maintenance issues to enhance infiltration at above freezing temperatures. For pavement operation in cold climates, readers may refer to papers by Backstrom (2000) and Roseen et al. (2012). However, it is relevant to note that porous pavements seem to be more resistant to freezing than standard pavements, because of their disconnection to subsurface moisture and because they thaw more rapidly due to infiltration of melt water (Backstrom 2000).

Houle et al. (2013) compared maintenance costs, labor demands and system performances for various sustainable drainage systems with conventional storm water management systems. The findings indicate that sustainable drainage systems have lower maintenance burdens and higher runoff treatment capabilities as a function of pollutant removal performance.

Infiltration through well-maintained pavement surfaces that let water through is usually modeled using the complex Green-Ampt equations, which have physically-based parameters that can be predicted. Infiltration is thus related to the volume of water infiltrated, and to the moisture conditions in the porous pavers and bedding layer (James and von Langsdorf 2003). The accumulation of unwanted material such as silt and debris should be prevented to maintain the hydraulic design properties.

Green and Ampt provided an approach that is based on fundamental physics, but also gives results that match empirical observations in the laboratory. However, the set of equations is difficult to apply to the field or landscape scale; e.g. the suction forces at the wetting front cannot be accurately described (Scholz and Grabowiecki 2007).

Moreover, physical clogging and biochemical processes (e.g., biological degradation of organic matter such as leaves) associated with poor maintenance are not considered. The presentation of any equations is beyond the scope of this sub-chapter.

Percolation or trickling represents the vertical flow (by gravity alone) of water from the unsaturated zone (i.e. voids filled with air) to the saturated zone (i.e. voids filled with water) of the base layer, and is the only inflow source to the saturated zone assuming that there is no water exchange with the surrounding environment below the ground level. Subgrade discharge represents lateral flow from the saturated zone of the base to the receiving water. Deep percolation represents a lumped sink term for not quantified losses from the saturated zone of the base. Two primary losses are assumed to be percolation through the confining layer and lateral outflow to somewhere other than the receiving water (James and von Langsdorf 2003).

The surface infiltration rates of 48 permeable pavement sites were tested in North Carolina, Maryland, Virginia and Delaware (Bean et al. 2004). Maintenance consisted of removing residual material located on top of the pavement system. The specific locations of pavements, and their usage and associated maintenance types and regimes influenced infiltration rates greatly.

Concrete grid pavers and permeable interlocking concrete pavers were tested with pavement ages ranging between 0.5 and 20 days (Bean et al. 2004). Analysis of the data showed that maintenance (i.e. cleaning of pavers at the end of each experiment) improved permeability on 13 out of 14 sites at a confidence level of 99.8 %. Fine particles had infiltration rates significantly less than sites free of loose fines. Even the minimum existing infiltration rates were comparable to those of a grassed sandy loam soil. The findings are interesting, but the short interval times do not represent reality well.

Kayhanian et al. (2012a) undertook permeability measurements and scanning images to investigate clogging of pervious concrete pavements in parking lots. The age of the parking lot was the predominant factor influencing the permeability. Statistical analysis revealed that fine sediment, number of days at relatively high temperature and the amount of vegetation next to the parking lot were important variables influencing clogging. The research confirms the importance of location and associated boundary conditions (Bean et al. 2004).

If locally acceptable, vacuum maintenance vehicles can be used to remove fine sediment. This is a common practice for relatively large pervious pavements. In comparison, similar devices are used for permeable pavers, but the removed sand between the pavers is usually replaced to avoid clay, silt and detritus entering the subgrade.

Infiltration supports groundwater recharge, decreases groundwater salinity, allows smaller diameters for sewers (resulting in cost reduction) and improves water quality of receiving waters, because pollutants and high peak flow are effectively controlled. On the other hand, pollutants in runoff originating from domestic and industrial emissions and traffic threaten soil and groundwater, if they are not removed from runoff before it infiltrates into the ground (Dierkes et al. 2002; Scholz 2006a).

## 7.6 Water Quality Improvements

This sub-chapter is predominantly concerned with the water quality of the runoff treated by permeable pavement systems, and removed from the reservoir base layers either for recycling or disposal. The quality of water infiltrating into the native subgrade and any associated potential groundwater contamination is not within the scope of this sub-chapter.

In contrast to permeable pavement surfaces, impervious surfaces have a high potential for introducing pollution to watercourses. Possible water quality variables of concern include the following (D'Arcy et al. 1998; NCDENR 2005; Scholz 2006b, 2010): sediment and suspended solids (including phosphorus and some metals); organic waste with high biochemical oxygen demand; dissolved nutrients and pollutants (including nitrogen, heavy metals, solvents, herbicides and pesticides); oil and grease; and fecal pathogens.

Permeable pavement systems have a good track record at removing suspended solids and nitrogen. Their water quality improvement potential has also been successfully modeled using self-organizing maps (Tota-Maharaj and Scholz 2013a). However, pavement systems, which do not rely on below ground infiltration or the use of an under drain system, are unlikely to be successful in the removal of nitrogen. When an under drain system is incorporated into the pavement design, storm water tends not to infiltrate into the soil, but into the under drain, where it can be denitrified or removed by plant uptake (NCDENR 2005).

Kayhanian et al. (2012b) reviewed highway runoff characteristics from different continents. Most metal pollutants and phosphorus were present in both particulate and dissolved forms. Strong correlations were observed between solids and hydrocarbons and between solids and metals. Furthermore, Dierkes et al. (2002) summarized possible ranges of pollutant concentrations in road runoff and rain, taken from more than 60 sites throughout Europe. Hydrocarbons, lead and copper show the highest pollutant concentrations in road runoff. Rain may contain 5 day biochemical oxygen demand (1–2 mg/l), sulfate (0.56–14.40 mg/l), chloride (0.2–5.2 mg/l), ammonia (0.1–2.0 mg/l), nitrate (0.1–7.4 mg/l), total phosphate (0.01–0.19 mg/l), copper (1–355 µg/l) and zinc (5–235 µg/l). Phosphorous and inorganic nitrogen concentrations are generally lower than those of organic substances. These pollutants are potentially harmful to receiving waters (Dierkes et al. 2002).

Brattebo and Booth (2003) detected oil and diesel fuel contamination at relatively high levels on non-permeable surfaces. In comparison, these contaminants were not detected on permeable pavement surfaces. Hydrocarbons can endanger soil and groundwater, if they are not removed sufficiently during infiltration through the surface layer (Dierkes et al. 2002). Many pollutants such as polycyclic aromatic hydrocarbons, metals, phosphorous and organic compounds are absorbed onto suspended solids. Models have been designed to estimate the suspended solids load and its dynamics during rainfall events, leading to better understanding of receiving waters being polluted by hydrocarbons (Rossia et al. 2005).



Concerning various pavement systems, Booth and Leavitt (1999) showed that infiltrated water had significantly lower levels of copper and zinc in comparison to the direct surface runoff from an impermeable asphalt area. Motor oil was detected in 89 % of samples from the asphalt runoff, but not in any outflow water sample from the permeable pavement system. Diesel fuel was not detected in any sample.

Various types of permeable pavements can operate as efficient hydrocarbon traps and powerful *in situ* bioreactors. Coupe et al. (2003) found out that a pavement system specifically inoculated with hydrocarbon-degrading micro-organisms does not successfully retain a viable population of organisms for the purpose of increased hydrocarbon degradation over many years. Naturally developed microbial communities (i.e. no inoculation with allochthonous microorganisms) degrade oil successfully.

For the successful biodegradation of polycyclic aromatic hydrocarbons, certain environmental conditions need to be met. Degradation takes place when prolonged aerobic, sulfate reducing and denitrifying conditions occur (Lei et al. 2005). Very large hydrocarbon spills can be contained due to absorption by media and accumulated particles within the permeable pavement (Newman et al. 2004).

Wilson et al. (2003) incorporated an oil interceptor into a porous surface construction. Tests were carried out for worst-case scenarios such as the worst possible combined pollution and rainfall event to assess how the system retains pollutants within its structure. The results successively demonstrated that this system can contain hydrocarbons, and can therefore offer outflow with improved water quality. However, where certain detergents are present in the pavement system, they can cause contamination of the outflow water, which may require secondary treatment to improve its water quality.

Studies have shown an improvement of water quality by filtration through permeable pavement systems, which work well in removing suspended solids and particularly heavy metals from runoff. For example, Legret et al. (1996) showed that suspended solids and lead can be reduced by permeable systems by up to 64 and 79 %, respectively.

Permeable pavement treatment performance could be enhanced by adding organic filter media. For example, Kellems et al. (2003) showed that enhanced filtration using organic media was an effective alternative to chemical precipitation for the treatment of storm water. Filtration through a specific adsorbent organic medium can remove about 95 % of dissolved copper and zinc.

In comparison to pavements made of impermeable asphalt, concentrations of zinc, copper and lead were significantly lower on permeable pavement structures (Brattebo and Booth 2003; Scholz 2006a). Lead concentrations were in fact undetectable. A permeable pavement system should regularly be kept clean to prevent clogging and accumulation of metals on the surface.

Particles usually accumulate in geotextiles and on permeable pavement surfaces. Geotextiles usually separate micro-pollutants such as cadmium, zinc and copper from the underlying soil, therefore preventing groundwater from becoming contaminated (Legret et al. 1996; Scholz 2013).



All types of permeable pavement systems are potentially powerful in situ bioreactors (biodegradation due to extended storage), which can reduce hydrocarbon contamination by 98.7 %. Biodegradation in permeable pavements is enhanced by bacteria and fungi (Coupe et al. 2003; Scholz 2013). When inoculated with microorganisms, the protozoan population diversity increases more rapidly than in similar non-inoculated system. Pavements contain testate amoebae, ciliates, flagellates and gymnamoebae. The understanding of microbial biodiversity helps to interpret biodegradation mechanisms (Coupe et al. 2003).

Permeable pavement systems have the capacity to degrade large quantities of clean motor oil. Commercially available oil-degrading microbial mixtures will frequently not degrade oil any better than the local microbial biomass established within the pavement over a long period of time. However, the local microbial biomass can only achieve high degradation rates, if there is adequate supply of nutrients (i.e. nitrogen and phosphorous) in the feed. Monitoring of biofilm development through scanning electron microscopy has revealed that a permeable pavement can obtain a high degree of biodiversity due to the development of complex microbial compositions (Newman et al. 2002).

The assessment of the microbiological water quality has been an important process in preventing waterborne diseases when recycling runoff treated by permeable pavement systems. The two most common tests carried out are for coliforms and *Escherichia coli*, or fecal coliforms (Barrell et al. 2000). Total coliforms, fecal coliforms, fecal streptococci, heterotrophs, fungi, *Pseudomonas aeruginosa*, *Legionella*, salmonellae and viruses are often analyzed in an attempt to determine the temporal distribution of bacterial pathogens and viruses in storm water runoff. However, findings usually show that it is not possible to accurately predict the time when peak microbial populations including human pathogens occur in recycled runoff waters.

## 7.7 Innovations and Future Research

Concerning porous concrete pavements, silica fume and super plasticizer can be added to standard porous concrete ingredients. This should improve the pavement allowing for higher loads, depending on the individual application conditions (Yang and Guoliang 2003; CIRIA 2007).

An additional layer of heat-bonded geotextile was introduced Newman et al. (2004) to the Formpave Sub-base of a permeable pavement system. This liner slowed down the release of small oil spillages, and their subsequent transport through the system. In case of an emergency, however, this solution cannot be used to protect large volumes of released oil, although the oil trap may significantly reduce the released amount of oil.

Permeable pavements can be combined with water recycling technology. The purpose is to collect treated runoff in a tanked belowground collection system for subsequent recycling. Applications may include car washing, garden sprinkling and

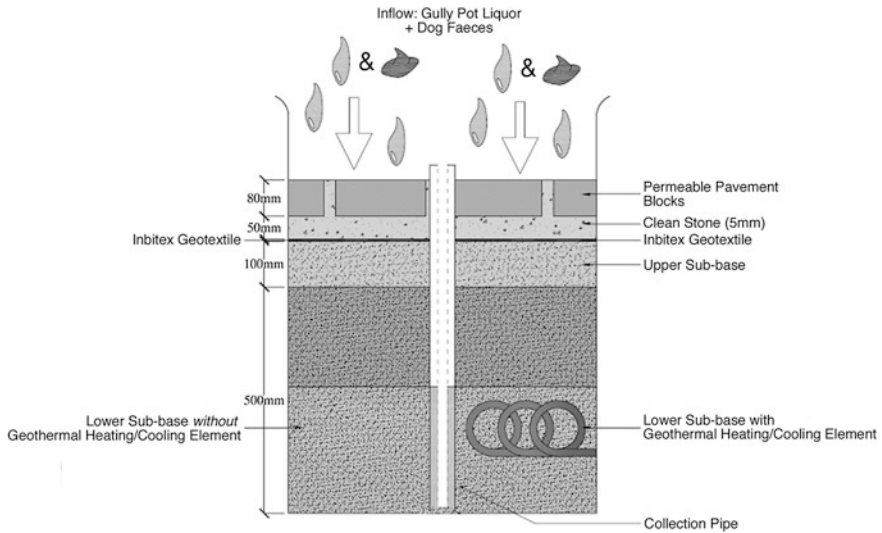

**Fig. 7.2** Combined pavements and geothermal heating/cooling system (*right hand-side*) and standalone pavement system (*left hand-side*); after Tota-Maharaj and Scholz (2010)

toilet flushing (Scholz and Grabowiecki 2007). If the treatment is insufficient for indoor recycling, additional purification is required. Therefore, Tota-Maharaj and Scholz (2013b) combined permeable pavements with photocatalytic titanium dioxide oxidation systems for urban runoff treatment and disinfection. The additional treatment resulted in recycled runoff fit for indoor applications such as toilet flushing.

More recently, pavement systems have been combined with ground source heat pumps. Tota-Maharaj and Scholz (2010) and Tota-Maharaj et al. (2010) reported on the impact on water quality by combining pavements and ground-source heat pumps with each other (Fig. 7.2). In addition to the obvious benefit of either heating or cooling nearby buildings, no significant effect on water quality deterioration due to a change in temperature within the water-logged sub-base was noted. No significant increase in potentially pathogenic organisms due to an increase in temperature within the sub-base was recorded by Tota-Maharaj et al. (2010).

Further research on the short- and long-term effects of contaminants that remain in the pavement system should be undertaken. The sustainability of these relatively new systems in comparison to traditional pavements requires further assessment.

Finally, as permeable pavements are becoming established as environmental friendly engineering techniques, there is a need for the development of simple computer-based decision support tools for engineers and planners. Attempts to incorporate modern pavement systems into a sustainable drainage decision support model were made by Scholz et al. (2006), and Scholz and Uzomah (2013).

## 7.8 Conclusions

This chapter summarized the literature on modern permeable pavement systems and related structures. Permeable pavement systems have become an important integral part of sustainable drainage systems, particularly in Europe. In comparison, porous pavements are sometimes associated with clogging problems.

Design, maintenance and water quality control aspects relevant to the practitioner were outlined for permeable pavements using concrete pavers and related systems. The most important target pollutants were suspended solids, hydrocarbons, heavy metals and nutrients (i.e. nitrogen and phosphorus). More recent focus is on fecal coliforms introduced to porous paving via dog droppings. The advantages and disadvantages of different pavement surface systems were discussed with the help of case studies concerning different water quality aspects.

Recent innovations were highlighted and explained, and their potential for further research work was outlined. Further work on the assessment of the sustainability of permeable pavement systems (including their maintenance) used for water quality control and runoff recycling is encouraged.

## References

- Abbot, C. L., & Comino-Mateos, L. (2003). In-situ hydraulic performance of a permeable pavement sustainable urban drainage system. *Journal of the Chartered Institution of Water and Environmental Management*, 17, 187–190.
- Andersen, C. T., Foster, I. D. L., & Pratt, C. J. (1999). The role of urban surfaces (permeable pavements) in regulating drainage and evaporation: Development of a laboratory simulation experiment. *Hydrologic Process*, 13, 597–609.
- Backstrom, M. (2000). Ground temperature in porous pavement during freezing and thawing. *Journal of Transportation Engineering*, 126, 375–381.
- Balkema, A. J., Preisig, H. A., Otterpohl, R., & Lambert, F. J. D. (2002). Indicators for the sustainability assessment of wastewater treatment systems. *Urban Water*, 4, 153–161.
- Barrell, R. A. E., Hunter, P. R., & Nichols, G. (2000). Microbiological standards for water and their relationship to health risk. *Communicable Disease and Public Health*, 3, 8–13.
- Bean, E. Z., Hunt, W. F., & Bidelsbach, D. A. (2004). Study on the surface infiltration rate of permeable pavements. In G. Sehlke, D. F. Hayes, & D. K. Stevens (Eds.), *Proceedings of the American Society of Civil Engineers and EWRI 2004 World Water and Environmental Resources Congress (27/06-01/07/2004)*. USA: Salt Lake City, UT.
- Booth, D. B., & Leavitt, J. (1999). Field evaluation of permeable pavement systems for improved storm water management. *American Planning Association Journal*, 65, 314–325.
- Brattebo, B. O., & Booth, D. B. (2003). Long-term storm water quantity and quality performance of permeable pavement systems. *Water Research*, 37, 4369–4376.
- Choubane, B., Page, G. C., & Musselman, J. A. (1998). Investigation of water permeability of coarse graded superpave pavements. *Journal of the Association of Asphalt Paving Technologists*, 67, 254–276.
- CIRIA (2007). *The SuDS manual*. London: Construction Industry Research and Information Association (CIRIA).
- Coupe, S. J., Smith, H. G., Newman, A. P., & Puehmeier, T. (2003). Biodegradation and microbial diversity within permeable pavements. *European Journal of Protistology*, 39, 495–498.

- D'Arcy, B. J., Usman, F., Griffiths, D., & Chatfield, P. (1998). Initiatives to tackle diffuse pollution in the UK. *Water Science Technology*, 38, 131–138.
- Dierkes, C., Kuhlman, L., Kandasamy, J., & Angelis, G. (2002). Pollution retention capability and maintenance of permeable pavements. In E. W. Strecker (Ed.), *Proceedings of the 9th International Conference on Urban Drainage (8–13 Sept 2002)*. USA: Portland.
- Houle, J. J., Roseen, R. M., Ballesterio, T. P., Puls, T. A., & Sherrard, J. (2013). Comparison of maintenance cost, labor demands, and system performance for LID and conventional stormwater management. *Journal of Environmental Engineering*, 139, 932–938.
- James, W., & von Langsdorf, H. (2003). Computer aided design of permeable concrete block pavement for reducing stressors and contaminants in an urban environment. In *Proceedings of the 7th International Conference on Concrete Block Paving (PAVE AFRICA, 12-15/10/2003)*, Sun City, South Africa.
- Kayhanian, M., Vichare, A., Green, P. G., Alaimo, C., Hwang, H. M., Signore, J. M., et al. (2010). Water quality evaluation of leachate produced from pavement specimens under controlled laboratory conditions. *Road Materials and Pavement Design*, 11, 9–28.
- Kayhanian, M., Anderson, D., Harvey, J., Jones, D., & Muhunthan, B. (2012a). Permeability measurement and scanning images to investigate clogging of pervious concrete pavements in parking lots. *Journal of Environmental Management*, 95, 114–123.
- Kayhanian, M., Fruchtman, B., Gulliver, J. S., Montanaro, C., & Raniere E (2012b) Review of highway runoff characteristics: comparative analysis and universal implications. *Wat Res*, 46, 6609–6624.
- Kellems, B. L., Johnson, P. E., Sanchez, F., & Crowser, H. (2003). Design of Emerging Technologies for Control and Removal of Storm water Pollutants. In P. Bizier & P. DeBarry (Eds.), *Proceedings of the Water World and Environmental Resources Congress (23-26/06/2003)*. USA: Philadelphia, PA.
- Legret, M., Colandini, V., & LeMarc, C. (1996). Effects of a porous pavement with reservoir structure on the quality of runoff water and soil. *Science of Total Environment*, 190, 335–340.
- Lei, L., Khodadoust, A. P., Suidana, M. T., & Tabak, H. H. (2005). Biodegradation of sediment-bound PAHs in field contaminated sediment. *Water Resource*, 39, 349–361.
- Li, H., Harvey, J., & Jones, D. (2012). Developing a mechanistic-empirical design procedure for fully permeable pavement under heavy traffic. *Transport Research Record: Journal of Transport Research Board*, 2305, 83–94.
- NCDENR (2005). Updated draft manual of storm water best management practices. Public Consultation Document DOC—7-1. North Carolina Department of Environment and Natural Resources (NCDENR), Division of Water Quality, NC, USA.
- Newman, A. P., Coupe, S. J., Puehmeier, T., Morgan, J. A., Henderson, J., & Pratt, C. J. (2002). Microbial ecology of oil degrading porous pavement structures. Global solutions for urban drainage. In E.W. Strecker (Eds.), *Proceedings of the 9th International Conference on Urban Drainage (08-13/09/2002)*, (pp. 1–12), Portland, OR, USA.
- Newman, A. P., Puehmeier, T., Kwok, V., Lam, M., Coupe, S. J., Shuttleworth, A., et al. (2004). Protecting groundwater with oil retaining pervious pavements: Historical perspectives, limitations and recent developments. *Quarterly Journal of Engineering Geology*, 37, 283–291.
- Nishigaki, M. (2000). Producing permeable blocks and pavement bricks from molten slag. *Waste Management*, 20, 185–192.
- Omoto, S., Yoshida, T., & Hata, S. (2002). Full-scale durability evaluation testing of interlocking block pavement with geotextile. *Proceedings of the 7th International Conference on Concrete Block Paving (PAVE AFRICA, 12-15/10/2003)*, Sun City, South Africa.
- Pagotto, C., Legret, M., & Le Cloirec, P. (2000). Comparison of the hydraulic behaviour and the quality of highway runoff water according to the type of pavement. *Water Research*, 34, 4446–4454.
- Pratt, C. J., Newman, A. P., & Bond, P. C. (1999). Mineral oil biodegradation within a permeable pavement: Long term observations. *Water Science Technology*, 39, 109–130.

- Roseen, R. M., Ballesterro, T. P., Houle, J. J., Briggs, J. F., & Houle, K. M. (2012). Water quality and hydrologic performance of a porous asphalt pavement as a storm-water treatment strategy in a cold climate. *Journal of Environmental Engineering*, 138, 81–89.
- Rossia, L., Krejcia, V., Rauch, W., Kreikenbauma, S., Fankhausera, R., & Gujera, W. (2005). Stochastic modeling of Total Suspended Solids (TSS) in urban areas during rain events. *Water Research*, 39, 4188–4196.
- Scholz, M. (2006a). Practical sustainable urban drainage system decision support tools. *Proceedings of the Institution of Civil Engineers—Engineering Sustainable*, 159, 117–125.
- Scholz, M. (2006b). *Wetland systems to control urban runoff*. Amsterdam: Elsevier.
- Scholz, M. (2010). *Wetland systems—storm water management control: Green energy and technology*. Berlin: Springer.
- Scholz, M. (2013). Water quality improvement performance of geotextiles within permeable paving systems: a critical review. *Water*, 5, 462–479.
- Scholz, M., & Grabowiecki, P. (2007). Review of permeable pavement systems. *Building and Environment*, 42, 3830–3836.
- Scholz, M., & Uzomah, V. (2013). Rapid decision support tool based on novel ecosystem service variables for retrofitting of permeable pavement systems in the presence of trees. *Science Total Environment*, 458–460, 486–498.
- Scholz, M., Corrigan, N. L., & Kazemi-Yazdi, S. (2006). The Glasgow SUDS management project: case studies (Belvidere hospital and celtic FC stadium areas). *Environmental Engineering Science*, 23(6), 908–922.
- Schlüter, W., & Jefferies, C. (2004). Modeling the outflow from a porous pavement. *Urban Water*, 4, 245–253.
- Tota-Maharaj, K., & Scholz, M. (2010). Efficiency of permeable pavement systems for the removal of urban runoff pollutants under varying environmental conditions. *Environmental Progress and Sustainable Energy*, 29, 358–369.
- Tota-Maharaj, K., & Scholz, M. (2013a). Modeling of permeable pavements for treatment of urban runoff using self-organizing maps. *Environmental Engineering Management Journal*, 12, 2273–2287.
- Tota-Maharaj, K., & Scholz, M. (2013b). Combined permeable pavement and photocatalytic titanium dioxide oxidation system for urban runoff treatment and disinfection. *Water Environmental Journal*, 27, 338–347.
- Tota-Maharaj, K., Scholz, M., Ahmed, T., French, C., & Pagaling, E. (2010). The synergy of permeable pavements and geothermal heat pumps for stormwater treatment and reuse. *Environmental Technology*, 31, 1517–1531.
- Wilson, S., Newman, A. P., Puehmeier, T., & Shuttleworth, A. (2003). Performance of an oil interceptor incorporated into a pervious pavement. *Proceedings of the Institution of Civil Engineers—Engineering Sustainability*, 156, 51–58.
- Yang, J., & Guoliang, J. (2003). Experimental study of pervious concrete pavement materials. *Cement and Concrete Research*, 33, 381–386.

# Chapter 8

## Pervious Concrete

John T. Kevern

**Abstract** The applications and benefits of using pervious concrete are immense and include everything from the common stormwater mitigation to more uncommon applications such as permafrost mitigation. This chapter will discuss the fundamental properties and behaviors of pervious concrete to provide background for future designs. Since stormwater management is covered in detail in the permeable pavements chapter, this chapter will discuss the aspects and applications unique to pervious concrete.

### 8.1 Background and Review of Important Functions

Pervious concrete has become a fundamental component to the creation of sustainable and resilient infrastructure. The primary applications as a pavement allow reduced stormwater volume, delay hydrologic peak flow, and improved stormwater quality all within the footprint of a conventional pavement (ACI 2010). Experience and observations from a vast number of installations have resulted in the realization of a number of significant unanticipated ancillary benefits. The interconnected pores allow for a potential reduction in the urban heat island while providing a quiet surface (Haselbach et al. 2011; Kevern et al. 2009a; Li 2012; Schaefer et al. 2010). When cement containing photocatalytic titanium dioxide has been included in pervious concrete the large surface area resulted in enhanced pollutant removal compared with conventional, impervious, photocatalytic pavement (Asadi et al. 2012). Its ability to pond melting water has shown a reduction in slip and fall potential (Kevern et al. 2012; King et al. 2013). The high pH and calcium levels provide heavy metal removal from stormwater (Haselbach et al. 2014). A wide variety of other applications like slope stabilization, manure dewatering and use as

---

J.T. Kevern (✉)

Department of Civil and Mechanical Engineering, School of Computing and Engineering, the University of Missouri-Kansas City, Kansas City, MO, USA  
e-mail: kevernj@umkc.edu

greenhouse floors help to highlight the range of successful uses (Luck and Workman 2007; Kevern 2006).

All permeable pavements, including pervious concrete, function as a load carrying surface and a high permeability conduit to infiltrate stormwater through the pavement surface. When designing and consideration permeable pavements, the surface material is only part of the entire permeable pavement system, which includes, at a minimum, a water storage layer and some amount of soil column beneath the storage layer. Depending on the soil type, additional drainage and/or non-woven geotextile fabric may be included in the design. The Chapter entitled, Permeable Pavements and Stormwater Management, broadly overviews the fundamental components and benefits provided by all permeable pavements. Consequently, this chapter will focus specifically on the unique properties and benefits of the Portland cement-based permeable pavement, pervious concrete.

## 8.2 Pervious Concrete Properties

The fundamental difference between conventional concrete and pervious concrete are the large interconnected void spaces. These void spaces control the resulting properties and performance far more than traditional considerations such as water-to-cement ratio ( $w/c$ ), cement content, or use of supplementary cementitious materials. Pervious concrete is unique in that a single set of mixture proportions can be compacted to a broad range of void contents. As the void content increases, the amount of material available for load transfer decreases. As the ability of the mixture to transfer load between the cement paste-coated aggregates decreases, the strength, elastic modulus, and durability also decrease (ACI 2010; Kevern and Montgomery 2010; Crouch et al. 2007). Correspondingly, with increased void content comes increased permeability (Meininger 1988; Kevern and Montgomery 2010).

To illustrate the importance of void content on material properties, Figs. 8.1, 8.2 and 8.3 show results from a single mixture compacted to five void contents. The mixture contained rounded river gravel coarse aggregate with 5 % sand (by both mass and volume) and had a volumetric paste-to-aggregate ratio ( $p/a$ ) of 0.22. All data points represent an average of three samples. Detailed information on the compaction density relationship for pervious concrete can be found in Meininger (1988) and Kevern et al. (2009a, b), Kevern and Montgomery (2010).

All pervious concrete mixtures produce a linear compaction density relationship, as shown in Fig. 8.1. Relationships can be defined for fresh or hardened concrete. The only notable difference is at a corresponding void content, a hardened sample will be significantly lighter than the fresh sample. The weight loss is caused by the evaporation of extra water contained in the aggregates and the water not used in hydration. Unit weight is highly effective for quality control and quality assurance, however the state of the sample (fresh or hardened) must be clearly stated (Kevern and Montgomery 2010; ACI 2013). Figure 8.2 shows corresponding samples tested for compressive strength at 7-days and permeability using a falling head device

**Fig. 8.1** Compaction density relationship for a single mixture

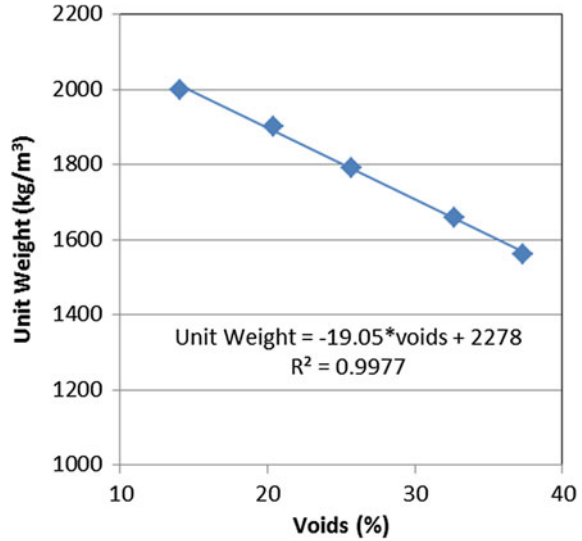

**Fig. 8.2** Strength and permeability relationship for a single mixture

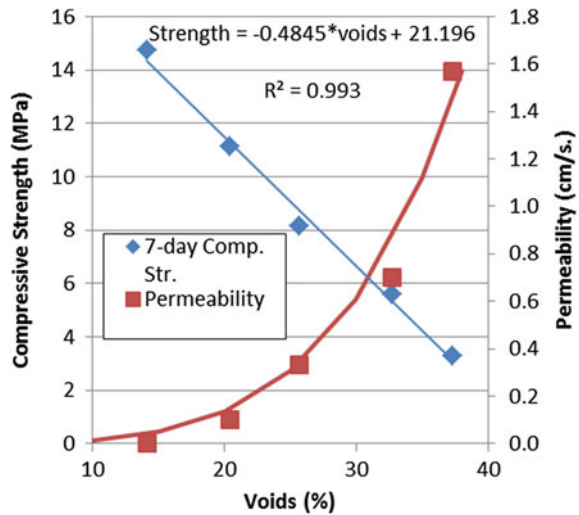

with a flexible membrane to minimize sidewall effects (Kevern 2014a). Strength decreases linearly with increased void content, while permeability follows the well-established Karmen-Cozeny relationship (Montes and Haselbach 2006). Figure 8.3 shows the same mixtures tested for freeze-thaw durability using ASTM C666A, the fully saturated, rapid freezing technique (ASTM 2003). Again as the void content increases and the strength correspondingly decreases, so does freeze-thaw durability. It should be noted that wide-spread freeze-thaw distresses have not been observed in the field with freeze-thaw durability issues only present when clogging



**Fig. 8.3** Freeze-thaw performance for a single mixture

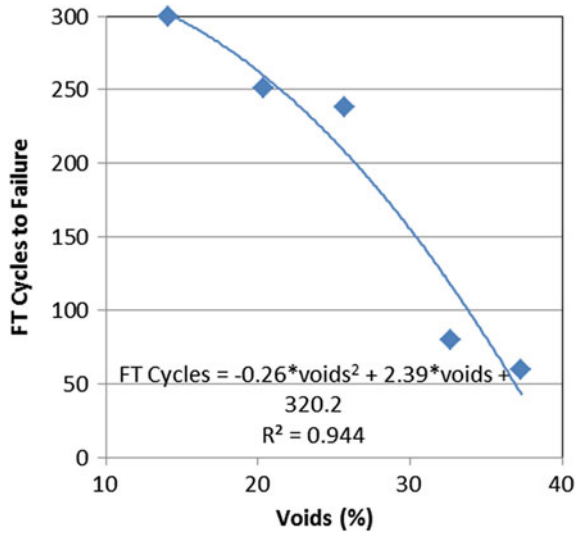

or poor construction practices and curing were observed (Delatte et al. 2007; Vancura et al. 2012).

One of the most persistent and incorrect assumption is the lack of freeze-thaw durability. Significant early work on the freeze-thaw durability of pervious concrete was performed by Anne Beeldens at the Dutch Road Research Institute and John Kevern currently at the University of Missouri-Kansas City. Research results have shown that the single biggest component to enhanced freeze-thaw durability is the inclusion of a small portion of sand (5–7 %) into the aggregate gradation (Beeldens 2001; Kevern et al. 2008b). Other components shown to improve freeze-thaw durability, in addition to fine aggregate and compaction, include:

- Durable coarse aggregate (Kevern et al. 2010)
- Air entrainment (Kevern et al. 2008c, 2009c)
- Polypropylene or cellulose, fibers (Kevern et al. 2008b, 2014)
- Latex admixtures (Beeldens 2001; Kevern et al. 2008b)
- Supplementary cementitious materials (Kevern et al. 2008a, 2011)
- Lightweight aggregate for internal curing (Kevern 2014b)
- Adequate curing (Kevern et al. 2009d).

### 8.3 Pervious Concrete Materials

Pervious concrete is comprised of basically the same components than conventional concrete of hydraulic cement, water, and aggregate. The permeability is achieved by using a coarse aggregate with around 40 % compacted void space and balancing

**Fig. 8.4** Pervious concrete surface texture



the volume of mortar to result in around 20 % porosity. While pervious concrete has been produced from sand sized to 19 mm (3/4 in.) aggregate, the most common aggregate size is around 9.75 mm (3/8 in.) (ACI 2010; Kevern et al. 2010). Figure 8.4 shows a close view of the surface texture of pervious concrete.

Mixture proportions for pervious concrete vary with regional experience and application. The cementitious materials, water, sand, and chemical admixtures are proportioned to produce a mortar which coats the coarse aggregate particles without draining off and without blocking the water-permeable pore space. The amount of water and chemical admixture dosage is directly related to the placement conditions and equipment. Since the mortar workability is designed to prevent paste mobility causing draindown, pervious concrete must be deposited near to the final location. Therefore the delivery vehicle must have access to the site or fresh concrete must be transported via belt-placing equipment or using small dump devices (Fig. 8.5). Stiffer mixtures may be successfully placed using mechanical equipment, while

**Fig. 8.5** Pervious concrete construction using a belt placer



hand placed application require a much more workable mixture. Generally, stiff, high paste content mixtures are most appropriate for heavy mechanized placement, and highly workable mixtures are used when the pervious concrete construction uses minimal compaction, such as roller-screed equipment. Matching the mixture to the application and construction placement technique is critical to a successful placement.

Typically the cementitious materials content ranges from 265 to 385 kg/m<sup>3</sup> (450 to 650 pcy) with water-to-cement ( $w/c$ ) ratios from 0.26 to 0.40 (ACI 2010). A small portion of fine aggregate (5–7 %) of the total aggregate gradation provides improved strength and durability (Beeldens 2001; Kevern et al. 2008b). The small portion of sand does reduce the overall porosity of the aggregate structure and is accounted in the volumetric proportioning of cementitious paste. The amount of coarse aggregate depends on the specific gravity, desired void content of the mixture, and paste-to-aggregate ( $p/a$ ) ratio. Most pervious concrete is proportioned with  $p/a$  from 0.19 to 0.24 (ACI 2010; Kevern 2006; Delatte et al. 2007).

While pervious concrete can be produced without admixtures, water reducing, air entraining, and hydration stabilization admixtures are most commonly used. The relatively low  $w/c$  combined with the high proportion of coarse aggregate results in a high abrasive environment when delivered using concrete mixer transit vehicles. The combination of cement grain size reduction and heat generation often result in sticky mixtures delivered to the site undergoing premature hydration (Kevern 2011a). Polycarboxylate High Range Water Reducing admixtures (HRWR) are included to provide additional workability required for proper placement. Hydration stabilizing admixtures are often included to help prevent premature hydration and allow redosing of water at the site if needed (NRMCA 2007). Air-entraining admixtures are included in cold climates to improve freeze-thaw durability (Kevern et al. 2008c). Viscosity Modifying Admixtures (VMAs) are often included to allow a higher  $w/c$  without causing draindown. The extra water allows better hydration and workability with moderate reduction in HRWR. Correct admixture selection is crucial to achieving.

One recent improvement to pervious concrete mixture proportioning has been the inclusion of internal curing materials. The low  $w/c$  and high exposed surface area make pervious concrete mixtures ideal for these techniques which allow the inclusion of more water to the mixture without significantly altering the paste workability. Prewetted lightweight fine aggregate and super absorbent polymers are the most common methods for internal curing of pervious concrete. When a lightweight fine aggregate is used the entire volume of conventional sand is replaced with prewetted fine aggregate. The absorption of lightweight fine aggregates range from around 15 % to up to 40 %. During hydration the water contained within the lightweight particles is drawn out to aid in curing. Results have shown that even though conventional sand is replaced with weaker, lightweight sand, the resulting pervious concrete is stronger and has improved freeze-thaw durability (Kevern 2014b). Super absorbent polymers are typically crystalline salts that can absorb many thousands of times their weight in water and also have a strong affinity for water. When super absorbent polymers are include in pervious concrete, that affinity for water reduces evaporation, improves the

degree of hydration, and durability (Kevern and Farney 2012). Of all the recent improvements to pervious concrete mixture proportioning, internal curing has shown great promise for improving strength and durability.

## 8.4 Pervious Concrete Applications

The most common pervious concrete applications are parking lots, sidewalks, and recreation trails for stormwater volume reduction (NRMCA 2007). Less common applications include low-volume roads and drains in the parking stalls of conventionally-paved roadways. For the vast majority of installations the pervious concrete is installed to manage stormwater volume. The additional benefits of urban heat island mitigation, permafrost protection, slip and fall reduction, or noise reduction are usually just ancillary. Figure 8.6 shows a pervious concrete pavement where foot traffic was present before plowing. The air contained in the pervious concrete and aggregate storage layer, combined with the earth warmth, caused the snow compacted by pedestrian traffic to preferentially melt.

Noise reduction and skid resistance is another benefit of pervious concrete pavement and when used as a high-speed roadway, a primary benefit. The first pervious concrete overlay for noise reduction and improved skid resistance was constructed in Minnesota, USA, in 2008. The 100 mm (4 in.) section was constructed over an existing concrete pavement without any active bonding technique. The concrete mixture contained 50 % replacement of cement with supplementary cementitious materials, sand, two types of fibers, and a highly durable aggregate (Kevern et al. 2011). The pavement section possessed high infiltration rate and was very quiet. Results ranged from a 50 to 100 % reduction in noise below a conventional quiet pavement of 100 dB using the on-board sound intensity technique (Schaefer et al. 2010). Figure 8.7 shows the pervious concrete overlay section after several years of service.

**Fig. 8.6** Reduced slip and fall potential of snow-covered pervious concrete



**Fig. 8.7** Pervious concrete overlay for noise reduction



One type of pervious concrete with limited use, but great future potential is precast pervious concrete. The modi slab in the Netherlands was the first commercial precast pervious product. The modi slab consists of a prestressed conventional concrete pavement topped with pervious concrete (Kevern 2008). The product was targeted for noise reduction and skid resistance for highway pavements. Full-depth prestressed pervious concrete panels are currently being used in Wisconsin (U.S.) as an alternative to cast in place pervious concrete. Figure 8.8 shows the installation of the hollow core, prestressed pervious concrete slabs. The production consistency and ability to provide near optimal curing at the crucial early ages, result in highly uniform surface texture and durability. Precast pervious concrete may be a highly desirable product, especially where trained contractors routinely placing pervious concrete are not available.

Since pervious concrete, and all permeable pavements, are both pavements and stormwater filters, long-term performance relates to both the structural performance as well as the environmental performance. Generally structural failure of pervious concrete has not been observed. Good structural performance has been observed in areas with routine truck loading indicating that the current pavement and base

**Fig. 8.8** Installation of precast hollow core pervious concrete pavement panels





thickness designs are adequate for the intended applications (Kevern 2008; Schaefer et al. 2010; Goede and Haselbach 2012; ACPA 2010). The most common distress observed on pervious concrete is raveling, where individual aggregate particles become dislodged from the surface (Kevern 2011b). Raveling typically does not impact the structural capacity, however, surface appearance and disabled person access may be negatively impacted. Also, the raveled particles further degrade the surface from additional friction between the tires and pavement, increasing the amount of fine particles on the surface to cause clogging. From an environmental standpoint long-term performance relates to the ability to infiltrate water through the surface. Chapter 1 discusses maintenance options for improving infiltration rates. Partial restoration of clogged pavements is possible, however some capacity will be permanently lost. As a best practice, pervious concrete should be protected from clogging during construction when unstabilized areas are present (Tong 2011).

Pervious concrete has been successfully utilized in parking areas, sidewalks, driveways, low volume roads, pedestrian areas, and many other locations. Good long term performance is directly related to the quality of the surface curing and protection of the pavement from excessive solids loading. Within these two considerations several notable uses to avoid include:

- Avoid areas of heavy turning traffic. Heavy turning traffic will cause raveling on sections with poor surface curing. Heavy turning traffic can also cause aggregate polishing and potential slipping hazards on mixtures using hard aggregate.
- Avoid areas with high impervious to pervious contributing area ratio. Areas with greater than 5:1 impervious to pervious contributing area tend to clog quickly and require frequent maintenance (Kevern 2011b).
- Avoid areas with known high suspended solids loading. Pervious concrete is a filter and areas with high solids loading also require more frequent maintenance.

## 8.5 Innovations and Future Research

While for the foreseeable future, pervious concrete will be utilized primarily for stormwater management, unique innovations will increase use for the ancillary benefits. Anecdotal evidence and limited laboratory testing has indicated that steel-reinforced pervious concrete may be more resistant to corrosion than conventional concrete. Figure 8.9 shows a reinforced pervious concrete wall located in Chicago, Illinois that was constructed in the early 1900s. Corrosion is only observed where conventional concrete has been used to patch spalled sections. Another potential non-pavement application is the use of pervious concrete as a retaining wall. The high permeability would prevent build-up of excess pore water pressure and reduce the potential for failure from clogged drains. Figure 8.10 shows a prototype pervious concrete retaining wall block used as a weep section.

One use of pervious concrete with great potential is as a stormwater best management practice installed on high shoulders. Using the shoulder as a linear

**Fig. 8.9** Reinforced pervious concrete walls



**Fig. 8.10** Pervious concrete retaining wall block



drain may allow stormwater volume reduction and treatment without requiring additional land area. A project funded by the Missouri Department of Transportation and the Federal Highway Administration developed hydraulic design procedures for pervious concrete shoulders and installed test sections in St. Louis, Missouri. Results indicate that a typical 4 m (12 foot) wide high shoulder paved with pervious concrete can successfully infiltrate water from three travel lanes at a variety of design storm depths (Cackler et al. 2012; Grahl et al. 2013; This is adequately referenced by Grahl et al. 2013, FHWA paper).

## 8.6 Conclusions

This chapter discussed the design, material behavior, current uses, and future applications of pervious concrete. The benefits of using pervious concrete are numerous and it is clear that this technology is crucial to long-term sustainable

development. Pervious concrete functions well as a stormwater management tool for water volume reduction. Additional benefits such as water treatment, urban heat island mitigation, reduced slip and fall potential, and as a quiet pavement have also been noted.

Pervious concrete performance is directly related to the resulting porosity of the mixture. Higher porosity mixtures have better flow properties, however, lower strength and durability. For typical pavement applications a balance of strength and permeability is observed around 20 % voids.

The most common applications are parking areas, while sidewalks and pedestrian areas are also common. Pervious concrete has been successfully utilized in high truck traffic areas where results show it is a very quiet pavement. The most common installation technique is cast-in-place which is sensitive to proper curing for good surface durability. Precast pervious concrete has also been successfully utilized in both low and high traffic applications. The future of pervious concrete is promising with many structural and pavement applications on the horizon.

## References

- American Concrete Institute (ACI) Pervious concrete. (2010). 522-R10: ACI 522 Committee Report, ACI, Farmington Hills, MI.
- American Concrete Institute (ACI) Pervious concrete. (2013). 522.1-13: Specification for pervious concrete pavement, p. 7. Farmington Hills, MI: ACI.
- American Concrete Pavement Association (ACPA). (2010). *Pervious pave technical guidance*. Chicago, IL: American Concrete Pavement Association.
- Asadi, S., Hassan, M., Kevern, J.T., Rupnow, T.R. (2012). Development of photocatalytic pervious concrete pavement for air and stormwater improvements. *Transportation Research Record: Journal of the Transportation Research Board*, No. 2290, pp. 161–167. Washington, D.C.: Transportation Research Board of the National Academies. doi: [10.3141/2290-21](https://doi.org/10.3141/2290-21).
- ASTM, Standard C-666. (2003). *Standard test method for resistance of concrete to rapid freezing and thawing*. Annual book of ASTM standards. (Vol. 4, No. 2), West Conshohocken, PA: ASTM International.
- Beeldens, A. (2001). *Behavior of porous PCC under freeze-thaw cycling*. Paper presented at the tenth international congress on polymers in concrete, Honolulu.
- Cackler, T., Alleman, J., Kevern, J.T., Sikkema, J. (2012). *Technology demonstrations project: environmental impact benefits with “TX active” concrete pavement in Missouri DOT two-lift highway construction demonstration*. A report from the National Concrete Pavement Technology Center (CP Tech Center) for FHWA, pp 119. Ames, IA: Iowa State University.
- Crouch, L., Pitt, J., & Hewitt, R. (2007). Aggregate effects on pervious portland cement concrete static modulus of elasticity. *ASCE Journal of Materials in Civil Engineering*, 19(7), 561–568.
- Delatte, N., Miller, D., Mrkajic, A. (2007) Field performance investigation on parking lot and roadway pavements: final report, pp 79. RMC Research & Education Foundation.
- Goede, W., & Haselbach, I. (2012). Investigation into the structural performance of pervious concrete. *ASCE Journal of Transportation Engineering*, 138(1), 98–104.
- Grahl, N., Kevern, J.T., Richardson, J. (2013). Hydraulic design of pervious concrete shoulders. *International concrete sustainability conference, National Ready Mixed Concrete Association*, May 6–8, San Francisco, CA.
- Haselbach, L., Boyer, M., Kevern, J.T., Schaefer, V.R. (2011). Cyclic heat island impacts in traditional versus pervious concrete pavement systems. *Transportation Research Record*:



- Journal of the Transportation Research Board, No. 2240, pp. 107-115. Washington, D.C.: Transportation Research Board of the National Academies. doi: [10.3141/2240-14](https://doi.org/10.3141/2240-14).
- Haselbach, L., Poor, C., Tilson, J. (2014). Dissolved Zinc and Copper retention from stormwater runoff in ordinary portland cement pervious concrete. *Construction Building Materials* 53, 652–657 (accepted at time of print).
- Kevern, J. T. (2006). Mix design determination for freeze-thaw resistant portland cement pervious concrete. *Master's thesis*. Ames, IA: Iowa State University.
- Kevern, J.T., Wang, K., Schaefer, V. R. (2008a). Pervious concrete in severe exposures development of pollution-reducing pavement for northern cities. *ACI Concrete International Magazine*, 30, 43–49.
- Kevern, J.T., Schaefer, V.R., Wang, K., Suleiman, M.T. (2008b). Pervious concrete mixture proportions for improved freeze-thaw durability. *Journal of ASTM International* 5(2) doi [10.1520/JAI101320](https://doi.org/10.1520/JAI101320).
- Kevern, J. T., Wang, K., Schaefer, V. R. (2008c). A novel approach to determine entrained air content in pervious concrete. *Journal of ASTM International* 5(2), doi [10.1520/JAI101434](https://doi.org/10.1520/JAI101434).
- Kevern, J.T. (2008). Advancements in pervious concrete technology. *Ph.D. Dissertation*. Ames, IA: Iowa State University.
- Kevern, J.T., Schaefer, V.R., Wang, K. (2009a). Temperature behavior of a pervious concrete system. Transportation Research Record: Journal of the Transportation Research Board (TRB), Concrete Materials, No. 2098, pp. 94–101. Washington D.C.: Transportation Research Board of the National Academies. doi [10.3141/2098-10](https://doi.org/10.3141/2098-10).
- Kevern, J.T., Schaefer, V.R., Wang, K. (2009b). Predicting performance of pervious concrete using unit weight, NRMCA Concrete infocus Magazine, Reprinted from the *Proceedings of the 2009 NRMCA Concrete Technology Forum – Focus on Performance Prediction*, Silver Springs, MD, Nov–Dec.
- Kevern, J.T., Wang, K., Schaefer, V.R. (2009c). Test methods for characterizing air void systems in portland cement pervious concrete. *Journal of ASTM International Selected Technical Papers STP 1511 Recent Advancements in Concrete Freezing and Thawing (FT) Durability*, Vol. 6, No. 9, October.
- Kevern, J. T., Schaefer, V. R., Wang, K. (2009d). The effect of curing regime on pervious concrete abrasion resistance. *Journal of Testing and Evaluation* 37(4), JTE101761.
- Kevern, J.T., & Montgomery, J. (2010). Hitting the mark: A case study of a pervious concrete quality assurance program. *ACI Concrete International Magazine*, March.
- Kevern, J. T., Wang, K., Schaefer, V. R. (2010). The effect of coarse aggregate on the freeze-thaw durability of pervious concrete. *American Society of Civil Engineers Journal of Materials in Civil Engineering* 22(5), 469–475.
- Kevern, J.T., Schaefer, V.R., Wang, K. (2011). Mixture proportion development and performance evaluation for pervious concrete for overlay applications. *ACI Materials Journal*, July–August, Title No. 108-M47, 108(4), 439–448.
- Kevern, J.T. (2011a). Design of pervious concrete mixtures. Design software distributed by the National Pervious Concrete Paving Association (NPCPA) <http://www.npcpa.org/>, V3.0, CD-ROM.
- Kevern, J.T. (2011b). Operation and maintenance of pervious concrete pavements. 90th Annual Transportation Research Board Annual Meeting, p. 16, Washington D.C., January 23–27, 2011.
- Kevern, J.T., & Farney, C. (2012). Reducing curing requirements for pervious concrete using a superabsorbent polymer for internal curing. Transportation Research Record: Journal of the Transportation Research Board, No. 2290, pp. 115–121. Washington, D.C.: Transportation Research Board of the National Academies. doi [10.3141/2290-15](https://doi.org/10.3141/2290-15).
- Kevern, J. T., King, G. W., & Bruetsch, A. (2012). Pervious concrete surface characterization to reduce slip-related falls. *American Society of Civil Engineers Journal of Performance of Constructed Facilities*,. doi:[10.1061/\(ASCE\)CF.1943-5509.0000263](https://doi.org/10.1061/(ASCE)CF.1943-5509.0000263).
- King, G. W., Bruetsch, A., & Kevern, J. T. (2013). Slip-Related characterization of gait kinetics: investigation of pervious concrete as a slip-resistant walking surface. *Safety Science*, 57, 52–59. doi:[10.1016/j.ssci.2013.01.023](https://doi.org/10.1016/j.ssci.2013.01.023).

- Kevern, J.T. (2014a). Evaluating Permeability and Infiltration Requirements for Pervious Concrete. *ASTM Journal of Testing and Evaluation* (accepted at time of print).
- Kevern, J.T., Biddle, D., Cao, Q. (2014). Effect of macro-synthetic fibers on pervious concrete properties. *ASCE Journal of Materials in Civil Engineering* (accepted at time of print).
- Kevern, J.T. (2014b). Reducing the curing requirements of pervious concrete using prewetted lightweight aggregate for internal curing. Report from the University of Missouri-Kansas City to the Expanded Clay, Shale, and Slate Institute, p. 14.
- Li, H. (2012). Evaluation of cool pavement strategies for heat island mitigation (improving outdoor thermal environment in hot climates through cool pavement design strategies), p. 389. *Ph.D. Dissertation*, Department of Civil and Environmental Engineering, University of California, Davis, Research Report UCD-ITS-RR-12-33.
- Luck, J., & Workman, S. (2007). Effect of pervious concrete on potential environmental impacts from animal production facilities. Portland Cement Association, PCA R&D No. 2993a, Skokie, IL.
- Meininger, R. C. (1988). No-fines pervious concrete for paving. *Concrete International* 10, 20–27.
- Montes, F., & Haselbach, L. M. (2006). Measuring hydraulic conductivity in pervious concrete. *Environmental Engineering Science* 23, 960–969.
- National Ready Mixed Concrete Association (NRMCA). (2007). Text reference for pervious concrete contractor certification, publication 2PPCRT, p. 60. NRMCA: Silver Spring, MD.
- Schaefer, V.R., Kevern, J.T., Izevbekhai, B., Wang, K., Cutler, H., Wiegand, P. (2010). Construction and performance of the pervious concrete overlay at MnROAD. Transportation Research Record: Journal of the Transportation Research Board (TRB), Concrete Materials, No. 2164, pp. 82–88. Washington D.C.: Transportation Research Board of the National Academies, doi [10.3141/2164-11](https://doi.org/10.3141/2164-11).
- Tong, B. (2011). Clogging effects of portland cement pervious concrete. *M.S. Thesis*. Iowa State University: Ames, IA.
- Vancura, M., MacDonald, K., Khazanovich, L. (2012). Location and depth of pervious concrete clogging material before and after void maintenance with common municipal utility vehicles. *ASCE Journal of Transportation Engineering* 138(3), 332–338.

## Chapter 9

# Photocatalytic Pavements

Joel K. Sikkema, James E. Alleman, Tom Cackler, Peter C. Taylor,  
Ben Bai, Say-Kee Ong and Kasthurirangan Gopalakrishnan

**Abstract** Pavements which have been blended, coated, sprayed, etc., with photocatalytic TiO<sub>2</sub> additives have attracted world-wide interest during the past decade-plus period based on their environmentally beneficial abilities to provide reactive (i.e., ‘smog-eating pavement’ plus ‘self-cleaning’) and reflective (i.e., ‘cool pavement’) impacts. The former ‘reactive’ capabilities notably involve a de-polluting property where TiO<sub>2</sub> irradiation with UV-A spectrum light is able to oxidatively convert a variety of problematic organic and inorganic pollutants within both atmospheric and aqueous runoff zones. This suite of transportation-generated amenable contaminants notably includes NO<sub>x</sub> residuals which otherwise represent a serious environmental and human-health challenge within high traffic density, inner-urban highway locations with high-density adjacent resident populations. Multiple laboratory-level photo-reactor studies published over the past several decades have demonstrated this photocatalytic NO<sub>x</sub>-removal capability, while at the same time scientifically exploring and elucidating key relationships between NO<sub>x</sub> abatement and various environmental factors (e.g., light wavelength and intensity, ambient relative humidity and surface moisture, pavement temperature, surface soiling impacts, etc.). Field monitoring, albeit in more limited fashion, has provided similarly supportive findings at a number of locations involving not only TiO<sub>2</sub>-bearing pavements but also locations paved with blocks, pavers, bricks, etc. which have been sprayed or coated with TiO<sub>2</sub>-enriched admixtures. This chapter, therefore, provides an overview of the related literature covering academic, industrial, patent, and related perspectives and both experimental and full-scale findings. While this existing body of knowledge is substantial, complementary

---

J.K. Sikkema

Engineering Department, Dordt College, Sioux Center, IA Ames, USA

J.E. Alleman (✉) · B. Bai · S.-K. Ong · K. Gopalakrishnan

Department of Civil, Construction and Environmental Engineering, Iowa State University,  
Ames, IA 50011, USA

e-mail: jea@iastate.edu

T. Cackler · P.C. Taylor

National Concrete Pavement Technology Center, Institute for Transportation, Iowa State  
University, Ames, IA, USA

© Springer-Verlag Berlin Heidelberg 2014

K. Gopalakrishnan et al. (eds.), *Climate Change, Energy, Sustainability and Pavements*,  
Green Energy and Technology, DOI 10.1007/978-3-662-44719-2\_9

275

conclusions are also provided regarding recommendations for additional research which appears warranted to pragmatically strengthen the future understanding of TiO<sub>2</sub>-related pavement performance.

## 9.1 Application Overview

Titanium dioxide (TiO<sub>2</sub>) is a natural, mineral compound whose unusual chemical properties have led to a diverse range of commercial and industrial applications ranging from whitening additives used in paints, food colorings, candy coatings, toothpastes, reflective sun screen materials, etc., or as surface ‘wetting’ and anti-fogging agents, or as photo-reactive chemical catalysts. Within the latter category, there are a large and rapidly escalating number of commercial TiO<sub>2</sub> applications where this chemical’s use is intended to advance a variety of positive environmental benefits, including:

- ‘De-polluting’ pavement air- or water-cleaning applications where TiO<sub>2</sub>-reactive surfaces are able to oxidatively convert air, water, and even surface-bound contaminants which might otherwise induce environmental fouling;
- ‘Cool’ pavement applications where a TiO<sub>2</sub> treated surface provides a seemingly brighter-white and more reflective (i.e. higher albedo) top boundary, such that its use within pavement, roofing, wall, etc. surfaces might be expected to reduce the absorption and subsequent convective re-release of solar radiation which might lead to undesirable urban heat island impacts, and
- ‘Self-cleaning’ pavement or architectural concrete applications (i.e., used on buildings, patios, walkways, sidewalks, courtyards, bridge deck-surface-barrier surfaces, etc.) which are capable of chemically cleaning contaminants which might otherwise foul and discolor their surfaces.

Table 9.1 accordingly provides a general overview of the broad ranging beneficial areas where products and/or application areas are based on TiO<sub>2</sub>-based reactive, reflective, and even super-hydrophilic, de-fogging technologies.

## 9.2 Historical Background

Keidel (1929) is believed to have published the earliest reference to TiO<sub>2</sub>’s sun-light-induced chemical reaction capabilities, where he observed and reported on degradation of fabrics incorporating TiO<sub>2</sub>. Goodeve and Kitchener (1938) subsequently reported another study showing TiO<sub>2</sub>-related photo-bleaching of dyes. By the 1960s, Fujishima and Honda (1972) carried out what is believed to have been the seminal research demonstration of TiO<sub>2</sub>’s potential for practical photocatalytic applications. Their study found that light (at a wavelength below 415 nm) induced a

**Table 9.1** Overview of current commercial environmental application areas for TiO<sub>2</sub>

Application area	Policy barriers
Air purification	Air pollutant treatment
	Deodorization
Water purification	Water pollutant treatment
	Disinfection
Vehicle windows and mirrors	Glass anti-fogging
Architectural and outdoor art structures	Self-cleaning exterior surfaces
Residential	Interior—curtains, wallpaper, windows
	Exterior—paint, tile, glass, tent
Agricultural	Residual pesticide removal
	Deodorization
	Hydroponic culture systems
Medical	Cancer treatment room purification
	Catheters and operating room purification
Electric appliances and lighting	Refrigerator purification
	Interior and exterior fluorescent lights
	Tunnel lighting
Highway pavements and paver walkway, patios, etc.	NO <sub>x</sub> removal via reactive TiO <sub>2</sub> surface treatments with pavement, noise barriers, crash barriers, etc.
	Cool pavement enhanced solar irradiation reflectivity which then reduces urban heat island impacts
Energy	Solar cells
	Water splitting and hydrogen evolution

photocurrent between TiO<sub>2</sub> and platinum electrodes immersed in an aqueous solution, resulting in oxygen and hydrogen evolution.

While the initial research following these prior discoveries tended to focus on enhancements to improve water decomposition, by Frank and Bard (1977) researchers started studying yet another set of environmental applications whose outcomes harkened back to the very earliest TiO<sub>2</sub>-catalyzed chemical degradation studies. For example, Frank and Bard (1977) employed TiO<sub>2</sub> as a photocatalyst to oxidize cyanide ions (a frequent, problematic industrial processing residual). In this study, a sample's cyanide concentration was reduced by up to 54 % when illuminated by a xenon lamp for 30 min in the presence of TiO<sub>2</sub>. Furthermore, when samples were placed in sunlight for 2 days, removal levels exceeding 99 % were observed. These new findings channeled interest towards environmental applications that address aqueous and airborne pollutants.

A chronological overview of TiO<sub>2</sub> photocatalysis technical publications is commensurately provided in Fig. 9.1, as based from a chronological summary published by Hashimoto et al. (2005).

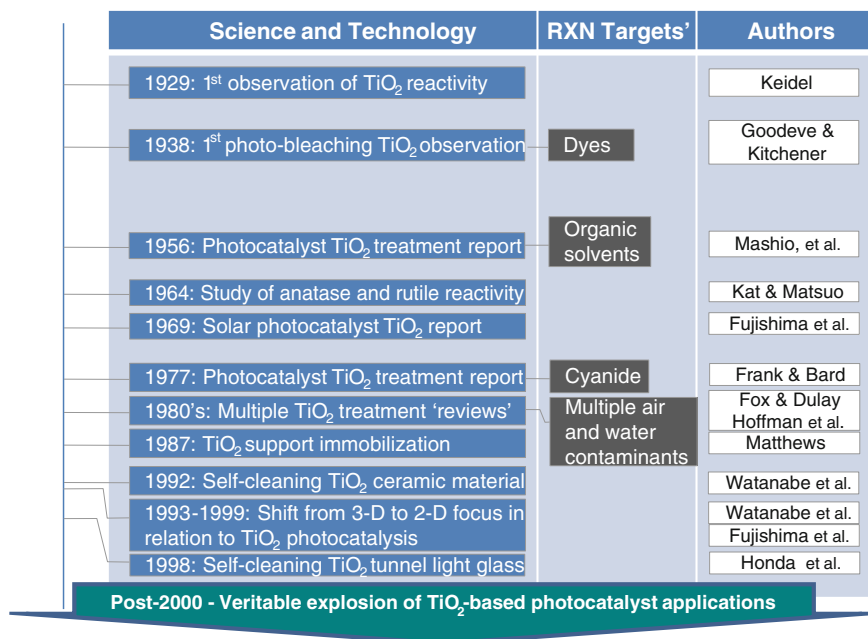

**Fig. 9.1** Evolution of TiO<sub>2</sub> photocatalysis technology [Note Extracted from Hashimoto et al. (2005)]

### 9.3 Literature Review Summary of TiO<sub>2</sub> De-Polluting Capabilities

The published literature documenting the gas-phase 'de-polluting' capabilities of TiO<sub>2</sub> photocatalysis, as covered in Table 9.2, shows prospective pavement-related environmental benefits which nearly cover the entire spectrum of National Ambient Air Quality Standards (NAAQS) criteria, excluding only the general category of particulate materials. Even then, it is certainly noteworthy that VOC removal would have additional benefits with lowering otherwise problematic near-road ozone given that VOCs are a precursor to problematic tropospheric ozone formation.

### 9.4 Regulatory Drivers for Considering TiO<sub>2</sub> Pavements

Within the United States, one of primary drivers for considering the use of TiO<sub>2</sub>-related pavements is that of reducing the atmospheric presence of NO<sub>x</sub> from motor vehicles. This motivation is tied to the US National Ambient Air Quality Standards (NAAQS), which receive their authority from the Clean Air Act (CAA) and subsequent amendments (Clean Air Act 2008). Nitrogen dioxide (NO<sub>2</sub>) is understandably

**Table 9.2** Emissions and TiO<sub>2</sub>-based photocatalytic reactions for mobile source pollutant indicators

Pollutant <sup>1</sup>	Selected associated species	TiO <sub>2</sub> -based photocatalytic reactions	References
Carbon monoxide	CO	$\text{CO} + \text{O}^{*2} \rightarrow \text{CO}_2$	Hwang et al. (2003)
Lead	Pb(II)	$\bullet\text{R}^3 + \text{Pb(II)} \rightarrow \text{R}_{\text{OX}} + \text{Pb(I)}$ (inhibited by oxygen, best suited for aqueous treatment)	Murrini et al. (2008)
Nitrogen oxide(s)	NO <sub>2</sub> , NO	$\text{NO}_2 + \bullet\text{OH} \rightarrow \text{NO}_3^- + \text{H}^+$ , $\text{NO} + 2\bullet\text{OH} \rightarrow \text{NO}_2 + \text{H}_2\text{O}$	Dalton et al. (2002)
Volatile organic compounds (VOCs)	C <sub>4</sub> H <sub>6</sub> , C <sub>6</sub> H <sub>5</sub> CH <sub>3</sub> , C <sub>8</sub> H <sub>10</sub> , CH <sub>2</sub> O, C <sub>4</sub> H <sub>9</sub> OH, (CH <sub>3</sub> ) <sub>2</sub> CO, CH <sub>3</sub> (CH <sub>2</sub> ) <sub>2</sub> CHO	Multiple reactions possible	Obee and Brown (1995), Peral and Ollis (1992)
Sulfur dioxide	SO <sub>2</sub> , HOSO <sub>2</sub>	$\bullet\text{OH} + \text{SO}_2 \rightarrow \text{HOSO}_2$ , $\text{HOSO}_2 + \text{O}^{*2} \rightarrow \bullet\text{OH} + \text{SO}_3$	Zhao et al. (2009)

included within this NAAQS list given that human exposure can cause infections, bronchitis, and emphysema (USEPA 2008). NO<sub>x</sub> also presents other environmental concerns. For example, small particles formed by the reaction of NO<sub>x</sub> with moisture and ammonia cause lung damage, and NO<sub>x</sub> represents a critical step in formation of tropospheric ozone which might similarly raise another layer of detrimental impacts on natural ecosystems and human respiratory systems. VOC emissions, while not regulated by NAAQS, are also of similar concern because NO<sub>x</sub> and VOC reactions in the presence of sunlight generate ozone (USEPA 1999).

The USEPA's NAAQS primary standards for NO<sub>x</sub> (i.e., which protect public health) (Clean Air Act 2008, § 7409(b)) were revised and strengthened in 2010 by supplementing the existing annually average 53 ppbv NO<sub>2</sub> primary and secondary standard with a new primary standard which designates an area as 'nonattainment' if the 3-year average of the 98th percentile of the annual distribution of the daily maximum 1-h average NO<sub>2</sub> concentrations exceeds 100 ppbv (Primary National Ambient Air Quality Standards for Nitrogen Dioxide: Final Rule 2010).

Near-road environments represent an area of particular concern. This concern arises from the fact that approximately 34 % of NO<sub>x</sub> emissions are from on-road motor vehicles (USEPA 2001) and that an estimated 35 million people (i.e., more than 10 % of the U.S. population) live within 100 m (300 ft) of major sources of these emissions (Thoma et al. 2008). Furthermore, multiple health studies have linked an increase in the observation of negative health effects with the proximity of populations to major roadways (Brauer et al. 2002; Brunekreef et al. 1997; Finkelstein et al. 2004; Garshick et al. 2003; Kim et al. 2004). Having identified that elevated exposure occurs in near-road environments, the 2010 final rule also required installation of near-road NO<sub>2</sub> monitors by 2013. These monitor must be located within 50 m of a road segment that is selected on the basis of Annual

Average Daily Traffic (AADT), but placement also requires consideration of “fleet mix, congestion patterns, terrain, geographic location, and meteorology” (USEPA 2010b). In these near-road locations,  $\text{NO}_2$  concentrations are 30–100 % higher than area-wide concentrations (USEPA 2010c). When developing the regulation’s impact assessment, USEPA did not have adequate data to predict which areas may violate the new 100 ppbv standard after these monitors are installed. The agency concluded “the possibility exists that there may be *many more* (emphasis added) potential nonattainment areas than have been analyzed” (Primary National Ambient Air Quality Standards for Nitrogen Dioxide: Final Rule 2010).

Conventional efforts to mitigate transportation sector air pollution focus on alternative vehicles and fuels, transportation policy, and emissions control technologies (Clean Air Act 2008; USEPA 2007). Many of these strategies have reached a point, though, where additional improvements in air quality will require novel approaches and significant expense (e.g., urea-based selective catalytic reduction). In the case of ambient  $\text{NO}_x$  pollution, documented negative health effects for those who live in near-road microenvironments indicate that further reductions in  $\text{NO}_x$  still needs to be sought. The substantial anticipated expense required to address current  $\text{NO}_x$  pollution indicates that mitigation strategies that fall outside of the current paradigm should be considered. Advances in photocatalytic concrete pavement performance may provide a new pathway to improve the sustainability of transportation by reducing the negative impacts associated with vehicle emissions. In turn, there is a motivation to further advance this technology with upcoming laboratory and field research.

## 9.5 $\text{NO}_x$ Emission and $\text{TiO}_2$ Photocatalysis Science Overview

As noted,  $\text{TiO}_2$ -based photocatalytic reactions oxidatively promote a variety of organic and inorganic pollutant degradations and related environmental benefits (Beeldens et al. 2011). In particular, the specific photocatalysis of  $\text{NO}_x$  from on-road motor vehicles has recently generated a substantial amount of research interest. Therefore, while these pavements catalyze oxidations for a variety of pollutants, this review places focus on reactions with  $\text{NO}_x$ . Pavement-specific literature refers to  $\text{NO}_x$  degradation as the ‘de $\text{NO}_x$ -process.’ This reactive mechanism has one stage for  $\text{NO}_2$ , two stages for  $\text{NO}$ , and is schematically illustrated in Fig. 9.2. The process begins when  $\text{NO}_x$  adsorbs on sites where  $\bullet\text{OH}$  is generated by exposed  $\text{TiO}_2$ . Adsorbed  $\text{NO}$  is oxidized to  $\text{NO}_2$  by the  $\bullet\text{OH}$ .  $\text{NO}_2$ , both adsorbed from the air and formed by oxidation of  $\text{NO}$ , is oxidized to nitrate ( $\text{NO}_3^-$ ). It is possible for  $\text{NO}_3^-$  to be bound to pavement surface by an alkali, but it is most probable that this product is flushed by water from the surface (Hüsken et al. 2009). The high probability that  $\text{NO}_3^-$  will be washed from the surface can be attributed to another unique photo-induced  $\text{TiO}_2$  property, super-hydrophilicity. Under sunlight,



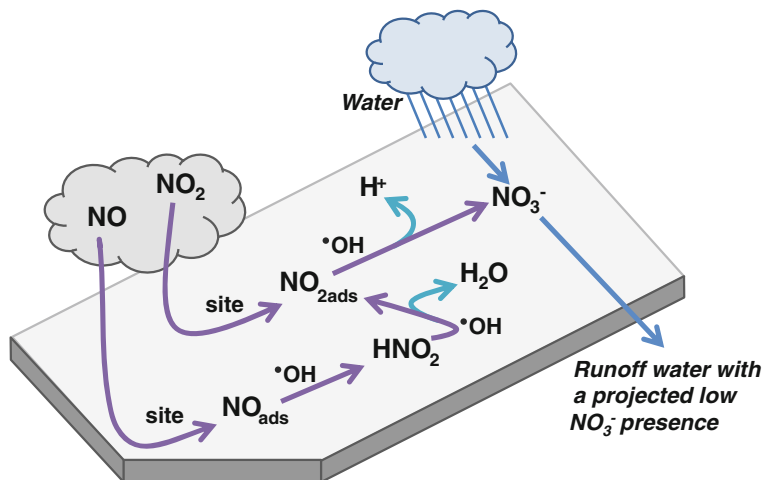
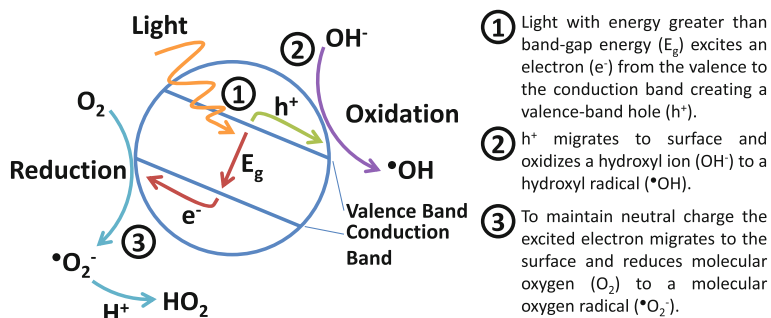

**Fig. 9.2** Photocatalytic oxidation of NO and NO<sub>2</sub> by concrete pavement surfaces which contain TiO<sub>2</sub>

water on the surface of a pavement containing TiO<sub>2</sub> spreads into a thin film with a contact angle of nearly 0°. This low contact angle allows water to penetrate between the pavement's surface and adsorbed material. This penetration lifts and flushes this material from the surface (Fujishima and Zhang 2006). Concentration of reaction products (i.e., NO<sub>2</sub><sup>-</sup> and NO<sub>3</sub><sup>-</sup>) has not been measured in the field, but one report estimates a maximum concentration of 1.2 mg/L-N, a value far below USEPA's 10 mg/L-N standard for drinking water (City Concept 2004; USEPA 2009).

While other photocatalytic materials are known to exist Ohama and Van Gemert (2011) have reported that the anatase crystal form of TiO<sub>2</sub> is the most effective option. The unique photocatalytic oxidation properties of TiO<sub>2</sub> are chiefly due to generation of hydroxyl radicals (•OH) under UV-A illumination (i.e., wavelength range of ~300–400 nm) (Fujishima and Zhang 2006). As illustrated in Fig. 9.3, when nanoscale TiO<sub>2</sub> particles absorb light with energy greater than the gap between valence and conduction bands (i.e., 1–3.3 electron volts), valence band electrons are excited and move to the conduction band (Tompkins et al. 2005).

This electron movement produces electron-hole pairs. TiO<sub>2</sub> particles, which are n-type semiconductors, contain sufficient numbers of mobile electrons that generation of electron-hole pairs do not significantly upset thermodynamic equilibrium. Therefore, the energy from light can be stored without compromising TiO<sub>2</sub> particle integrity. Once produced, electron holes tend to recombine with an electron, eliminating the hole-pair and releasing the stored energy as thermal energy or radiation. However, if the electron hole migrates to the particle surface, oxidative reactions are possible. In the typical photocatalytic oxidation process, an electron



**Fig. 9.3** Photocatalytic oxidation steps [i.e., adapted from Tompkins et al. (2005)]

from a hydroxyl ion fills the  $TiO_2$  particle's electron hole, creating a  $\bullet OH$ . This radical is highly reactive and can then oxidize various pollutant molecules (Fujishima et al. 2000).

Photocatalytic oxidation causes the  $TiO_2$  particle to gain electrons. A net gain of electrons threatens the continued usability of the particles for photocatalytic oxidation because a negative charge will develop if too many electrons are gained. This state has not been observed in practice. Research indicates that in many cases, a neutral charge is maintained when electrons leave  $TiO_2$  particles via reduction of molecular oxygen to radical oxygen (also illustrated in Fig. 9.3). The electron holes have a greater oxidizing power than the reducing power of excited electrons. Therefore, reduction of molecular oxygen does not cancel out the  $TiO_2$ 's oxidizing power. Of note, radical oxygen when reacted with hydrogen produces the hydroperoxyl radical, which also can oxidize certain molecules (Fujishima et al. 1999). Optimization of  $TiO_2$  for use as a photocatalyst is the subject of ongoing research. Anatase has the highest photocatalytic activity levels of common  $TiO_2$  mineral forms due to comparatively higher surface area and surface density of sites available for photocatalysis (Herrmann 1999). Although anatase  $TiO_2$  displays a comparatively high level of photo-activity, it only absorbs UV light (which represents approximately 5 % of sunlight). Enhanced photocatalytic activity could be obtained if the spectrum of light that  $TiO_2$  absorbs is increased. Efforts to achieve this result have included coupling with semiconductors, doping with metal, preparing  $TiO_2$  that is oxygen deficient, and doping with non-metal anions (Fujishima et al. 2008). Non-metal anion doping shows the greatest potential to achieve development of visible-light photocatalysts. Publications have reported that doping with nitrogen, carbon, sulfur, boron, phosphorus, and fluorine increases the spectrum of light that  $TiO_2$  absorbs to the visible range (Fujishima et al. 2008). These developments increase photocatalytic generation of  $\bullet OH$ , thereby increasing photocatalytic degradation of various pollutants. Undoubtedly, future developments will also enhance photo-degradation of  $NO_x$  by pavement containing  $TiO_2$ .

## 9.6 Commercial Development and Application Options

A summary of patents connected with TiO<sub>2</sub> photocatalytic air-cleaning applications was published by Paz (2010). This paper generally notes, “*that the number of scientific publications dedicated to photocatalytic air-cleaning is significantly lower ...*” than those connected with water treatment. Paz’s (2010) paper informatively provided a general review of various pavement-type applications and issues, including: (a) extruded block materials (i.e., in 1998 and 1999), spray-on applications (i.e., in 2002), shear-resistant materials (i.e., in 2005 and 2006), bituminous void-filling with reactive cement mortar (i.e., in 2007), and paint-related uses (e.g., in 2009). Table 9.3 summarizes eleven (11) patents believed to have been secured in direct relation to TiO<sub>2</sub>-bearing pavement (or similar paver, brick, tile, etc.) materials.

## 9.7 Published Test Results with Laboratory-Scale TiO<sub>2</sub> Pavement-Related Evaluations

*Laboratory-Scale Testing Systems* Laboratory-level studies completed using pavement-type laboratory samples tested within a flow-through photoreactor constitute a significant portion of this technology’s published body of literature. The employed test methods to evaluate oxidation of nitric oxide by photocatalytic pavements are provided by international, Japanese, and Italian standards (ISO 2007; JIS 2010; UNI 2007). Each standard provides a similar scope for a test method to determine removal of nitric oxide by photocatalytic ceramic materials. Although written to provide a standard testing approach for ceramics, the international standard has been similarly employed by a number of researchers for their assessment of photocatalytic concrete. NO<sub>x</sub> removal is determined by measuring the amount of pollutant removed from a test gas after it passes over a photocatalytic material housed within a flow-through photo-reactor (Fig. 9.4). The standard provides equations to determine the net number of moles of NO removed from the test gas by the sample, however, the bulk of publications report NO<sub>x</sub> removal as calculated by the following equation:

$$NO_x \text{ removal (\%)} = \frac{C_{NO_{xi}} - C_{NO_x}}{C_{NO_{xi}}} \times 100\%$$

The apparatus required to complete this determination are divided into the following groups: test gas supply, photoreactor, light source, and pollutant analyzer. The international ISO standard method (ISO 2007) proposes the following operating conditions: 1.0 ppmv NO input concentration, 50 % relative humidity, 3.0 L min<sup>-1</sup> flow rate, 50 mm photoreactor width, 5.0 ± 0.5 mm air pathway height, and 5 h sample irradiation duration. In order to test NO<sub>x</sub> reduction under various

**Table 9.3** Patent synopsis relative to TiO<sub>2</sub>-bearing pavement, block, tile, brick, etc. materials

#	Patent number	Date	Inventors and assignee	Topic
1	EP 0,786,283	1997	Murata et al. (2003)	NO <sub>x</sub> -Cleaning paving block <i>(Note involved a double-layer paving block having enhanced NO<sub>x</sub>-cleaning capability)</i>
2	US 6,117,229	2000	Cassar and Pepe (2000), (2002a, b), (2010)	Use of organic additives for the preparation of cementitious compositions with improved properties of constancy of color <i>(Note the use of photocatalytic anatase kept the 'white' luminance, purity (intensity of hue) and tonality of hue intact over time)</i>
3	6,406,536	2002	Cassar and Pepe (2000), (2002a, b), (2010)	Organic additives for the preparation of cementitious compositions with improved constancy of color <i>(Note Use of photocatalyst TiO<sub>2</sub> anatase "able to oxidize, in presence of light, air, and ambient humidity, pollutant substances in the environment"; "enables cementitious compositions to be obtained which are particularly suitable for being applied by brush, sprayer, or roller"; "It should be pointed out that the photocatalytic action need not necessarily be fast, in that the fouling of the product by environmental pollutants takes place slowly over time. For this reason, even extremely small percentages of photocatalysts may produce a very high effect of conservation of colour over time."; "Not to be excluded are also inorganic compounds, such as oxides of nitrogen NO<sub>x</sub> which may be oxidized to nitrates.")</i>
4	US 6,409,821	2002	Cassar and Pepe (2000), (2002a, b), (2010)	Hydraulic binder and cement compositions containing photocatalyst particles <i>(Note Covers hydraulic binder, dry premixes, and cement compositions... where these "compositions contain, in bulk, particles of a photocatalyst capable of oxidizing polluting substances in the environment in the presence of light, oxygen, and water...having improved property to maintain, after the installation, for longer time periods the brilliance and the colour quantity."</i>

(continued)

**Table 9.3** (continued)

#	Patent number	Date	Inventors and assignee	Topic
5	US 6,824,826	2004	Amadelli and Cassar (2004)	Use of photocatalytic preparations of colloidal titanium dioxide for preserving appearance of cementitious, stone, or marble products <i>(Note TiO<sub>2</sub> being used to preserve surface characteristics)</i>
6	US 7,300,514	2007	Bonafous et al. (2007)	Photocatalytic granular mixture for mortar and concrete and its use <i>(Note Using “at least two granular classes with different B.E.T. specific surfaces. It has a photocatalytic activity greater than that of a monodisperse photocatalyst...” and by which the new material “whose aptitude for self-cleaning, for the reduction of odors, and for the depollution of ambient air, is considerably improved.”)</i>
7	EP 1,600,430	2010	Cassar and Pepe (2000), (2002a, b), (2010)	Paving tile comprising a hydraulic binder and photocatalytic particles
8	US 7,960,042	2011	Cassar et al. (2011)	Cement-based paving blocks for photocatalytic paving for the abatement of Urban pollutants <i>(Note Cement-based paving block for photocatalytic paving for the abatement of urban pollutants (PAH, aldehydes, benzene, carbon black RE: PM10, oxides of nitrogen and sulfur, carbon monoxide...)</i>
9	US 8,039,100	2011	Cucitore et al. (2011)	High durability photocatalytic paving for reducing Urban polluting agents <i>(NOTE: prolonged capability even in the face of high mechanical stress caused by heavy traffic)</i>
10	US 8,092,586	2012	Ancora et al. (2012)	Titanium dioxide based photocatalytic composites and derived products on a Metakaolin support <i>(Note “...possible to obtain binders and derived products with high photocatalytic efficiency, even when using photocatalyst quantities which are lesser than those present in products of prior technical art.”)</i>

(continued)

**Table 9.3** (continued)

#	Patent number	Date	Inventors and assignee	Topic
11	US 20,120,270,721	2012	Guerrini (2012)	Cementitious products and articles of manufacture containing Carbon-doped titanium dioxide  (Note This patent addresses an improvement to the prior art with titanium dioxide in photocatalytic cementitious products, where, "... product articles of manufacture containing it have a high and efficient photocatalytic action.")

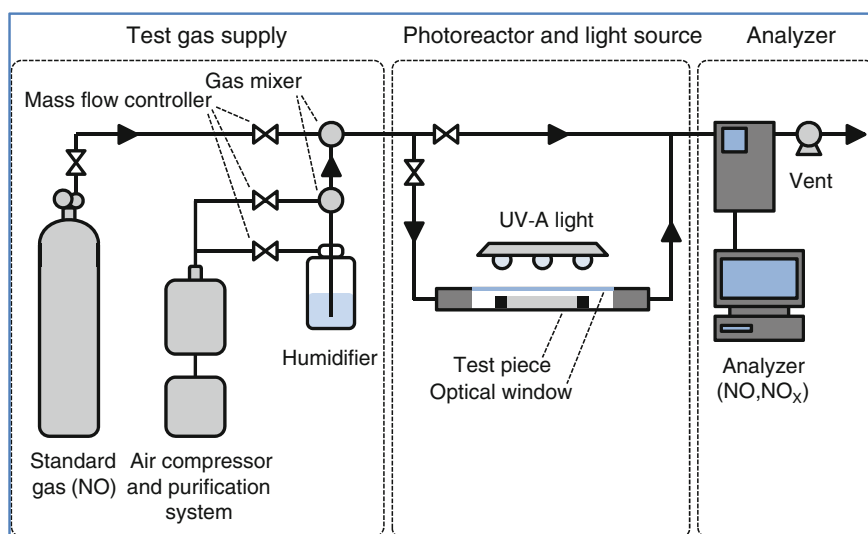
**Fig. 9.4** Schematic of experimental apparatus (adapted from ISO 2007)

environmental conditions, however, these conditions are frequently modified by various research teams.

*Laboratory-Scale General Testing Conditions and Results* To predict the performance of photocatalytic pavements under field conditions, researchers use photoreactor tests to measure NO<sub>x</sub> reduction under various environmental, material, and operation conditions. The earliest publications varied environmental variables of irradiance, relative humidity, NO<sub>x</sub> concentration, NO<sub>2</sub>/NO<sub>x</sub> fraction, and flow rate and the material variable, TiO<sub>2</sub> content. Table 9.4 provides an overview of the previously published lab-level experimental findings in regards to environmental conditions, material properties, and operational variables which impact NO<sub>x</sub> removal efficiency.

**Table 9.4** Summary of published lab-level photoreactor tests with mortars containing TiO<sub>2</sub>

Independent variable	Values tested		NO <sub>x</sub> removal (%)		Test conditions						TiO <sub>2</sub> (wt%)	Reference
	High	Low	High	Low	E (W m <sup>-2</sup> )	RH (%)	NO <sub>x</sub> (ppmv)	NO <sub>2</sub> /NO <sub>x</sub>	Q (L min <sup>-1</sup> )			
Irradiance (W m <sup>-2</sup> )	12	0	87 <sup>d</sup>	10 <sup>d</sup>		50	1.0	0	3	NR	Murata et al. (2000)	
	13	0.3	25 <sup>d</sup>	5 <sup>d</sup>		50	1.0	0	3.0	NR	Hüsken et al. (2009)	
	12.1	2.1	45.8	12.6		49.9 49.6	1.04	0.52	3	5.9 <sup>i</sup>	Ballari et al. (2011)	
Relative humidity (%)	80	10	52 <sup>d</sup>	87 <sup>d</sup>	6		1.0	0	3	NR	Murata et al. (2000)	
	80	10	13.6	32.3	10.0		1.0	0	3.0	NR	Hüsken and Brouwers (2008), Hüsken et al. (2009)	
	80	30	14 <sup>d</sup>	43 <sup>d</sup>	NR		0.41	0	NR	5	Dylla et al. (2010)	
NO <sub>x</sub> conc. (ppmv)	69.0	10.2	37.9	84.6	10.1		0.52	0	3	5.9 <sup>i</sup>	Ballari et al. (2011)	
	5.0 <sup>d</sup>	0.05	44 <sup>d</sup>	90 <sup>d</sup>	6	50		0	3	NR	Murata et al. (2000)	
	1.0	0.1	36.9	68.4	10.0	50		0	3.0	NR	Hüsken and Brouwers (2008), Hüsken et al. (2009)	
NO <sub>2</sub> /NO <sub>x</sub>	1.0	~0.1	20.5	64.29	10	50		0.01 and 0.02	3	NR	Ballari et al. (2010)	
	1.0	0.11	34.9	71.8	10	50.0		0	3	5.9 <sup>i</sup>	Ballari et al. (2011)	
	1.3	0.1	38 <sup>d</sup>	82 <sup>d</sup>	16	23, 24		0	3	NR	Sikkema et al. (2012)	
NO <sub>2</sub> /NO <sub>x</sub>	1	0	36.5	34.9	10.0	50.0, 49.8	1.01 0.99		3	5.9 <sup>i</sup>	Ballari et al. (2011)	
	0.70	0.0	41 <sup>d</sup>	74 <sup>d</sup>	20	20	0.55		3	5	Dylla et al. (2011a, b)	

(continued)

Table 9.4 (continued)

Independent variable	Values tested		NO <sub>x</sub> removal (%)		Test conditions					TiO <sub>2</sub> (wt%)	Reference
	High	Low	High	Low	E (W m <sup>-2</sup> )	RH (%)	NO <sub>x</sub> (ppmv)	NO <sub>2</sub> /NO <sub>x</sub>	Q (L min <sup>-1</sup> )		
Q (L min <sup>-1</sup> )	5	1	22.1	66.6	10.0	50	1.0	0		NR	Hüsken and Brouwers (2008), Hüsken et al. (2009)
TiO <sub>2</sub> (% by binder weight)	5	3	15.7	21.1	10	50	~1	0.2		NR	Ballari et al. (2010)
	9	3	21 <sup>d</sup>	61 <sup>d</sup>	NR	NR	0.41	0		5	Dylla et al. (2010)
	10	3	18.1	6.2	10	50	1	0	3		Hüsken et al. (2009)
TiO <sub>2</sub> (% by binder weight)	5	3	61 <sup>d</sup>	56 <sup>d</sup>	NR	?	0.41	0	3		Dylla et al. (2010)
	5	3	26.9	18.0	NR	50	0.41	0	9.0		Hassan et al. (2010a, b, c)

*d* = digitized from figure

NR = not reported

*i* = % by total weight



While Table 9.4 lists published  $\text{NO}_x$  removal percentages cited within each of these referenced laboratory studies, the published literature unfortunately does not provide a comparative evaluation of actual specific  $\text{NO}_x$  removal rates by which the expected real-world  $\text{NO}_x$  ‘de-polluting’ performance of these surfaces might be projected. An unpublished assessment of the latter reported laboratory literature (Sikkema 2013), though, concludes that the observed specific  $\text{NO}$  removal rates range from 6.2 to 46 nmol/s per square meter. Assuming that there is 12 h/day of available UV light, these values equate to  $\sim 8$ –62 tons  $\text{NO}$ /year per square mile of paved  $\text{TiO}_2$ -bearing paved surface. Within the United States, there are approximately 93,000 lane-miles of urban Interstate highways (FHWA 2011). Assuming a 12 ft lane width, this value represents 210  $\text{mi}^2$  of pavement. On a comparative basis, therefore, if all US urban Interstate highways were re-paved with photocatalytic pavements, and if their observed photocatalytic activities were within the aforementioned surficial activity range, this cumulative removal capacity would appear to be capable of oxidizing between 1,700 and 13,000 tons  $\text{NO}_x$ /year.

*Laboratory-Scale Results Relative to  $\text{TiO}_2$  Application Level and Mineral Types Plus Properties* An increase in the amount of  $\text{TiO}_2$  contained in the photocatalytic material (often measured as a percentage of binder mass) would be expected to increase  $\text{NO}_x$  removal (Dylla et al. 2010; Hassan et al. 2010a, b, c; Hüsken et al. 2009). Although this positive correlation is supported by literature, the relationship does not appear to follow a linear correlation. Studies of VOC oxidation by Strini et al. (2005) and Watts and Cooper (2008) have actually found that catalytic activity diminishes with increases in  $\text{TiO}_2$  content and have proposed that optimal  $\text{TiO}_2$  content falls between 1 and 5 %. This diminished return was attributed to aggregation and segregation of  $\text{TiO}_2$  grains at the material’s surface that resulted in a decrease in  $\text{TiO}_2$  concentration. Due to the nature of this relationship, it is not apparent whether this benefit is justified by the unit cost of  $\text{TiO}_2$  (Dylla et al. 2010). In this regard, it is also worth noting that  $\text{TiO}_2$  content is not frequently reported in photocatalytic pavement studies. Within patents governing this technology,  $\text{TiO}_2$  content as a percentage of binder appears to range from 2 to 10 % (Paz 2010). The circumstance where specific values are not available might be related to efforts intended to protect competitive commercial advantages. In turn, though, application stakeholders would assumedly then need to rely on the research and development process of the patent holders and on available data verifying the product’s performance. In addition to the content, the properties of  $\text{TiO}_2$  contained within a photocatalytic pavement also impact  $\text{NO}_x$  removal.  $\text{TiO}_2$  occurs in a variety of mineral forms, including anatase, brookite, and rutile. Although each mineral form is photocatalytically active, direct comparison finds that anatase is best-suited for photocatalytic oxidation applications because anatase is superior in both the rate at which electron-hole pairs are generated and has a better ability to adsorb reactants (Sclafani and Herrmann 1996). Although anatase is a superior photocatalyst, mixtures of rutile and anatase (e.g., Degussa P-25, which contains anatase and rutile at a 3:1 ratio) reportedly garner the greatest photo-activity due to interaction between the minerals (Ohno et al. 2001). In addition to an appropriate mixture of mineral forms, high specific surface area values have also been demonstrated to

enhance photocatalytic activity (Hüsken et al. 2009). Further discussion of TiO<sub>2</sub> properties which enhance photocatalytic activity falls outside of the scope of this review. If of interest to the reader Carp et al. (2004) would serve as a good starting point. As noted by Carp et al. (2004), particular research needs include ongoing and future research to develop special photocatalysts that can be activated by visible light (i.e., via innovative chemical doping) and are selective in the pollutants that are oxidized. Stakeholders considering use of photocatalytic pavements would be wise to follow developments in TiO<sub>2</sub> photocatalysts and if possible select a catalyst which incorporates worthwhile research developments.

*Laboratory-Scale Results Relative to UV Irradiance* Increased UV irradiance on a photocatalytic surface would be expected to increase the rate at which electron holes are created. An increase in electron-hole generation results in increased production of hydroxyl radicals, which oxidize NO<sub>x</sub>. Multiple publications report that the relationship between irradiance and pollutant oxidation can be divided into two regimes. These regimes are divided into a linear relationship below the regime division point and a non-linear relationship above this point (Herrmann et al. 2007; Jacoby et al. 1995; Kumar et al. 1995; Lim et al. 2000; Obee and Brown 1995). Jacoby et al. (1995) explains that under the linear regime, electron holes are filled by reactions with species on the photocatalytic surface (e.g., OH<sup>-</sup>) faster than by recombination with excited electrons. In contrast, under the non-linear regime, holes are filled by recombination at a faster rate than by reaction other species. Although these publications are in consensus that this regime is identifiable, reports of the regime division point irradiance value range from 10 to 250 W m<sup>-2</sup> (Herrmann et al. 2007; Lim et al. 2000). Photocatalytic pavement studies, which investigated the relationship between irradiance and NO<sub>x</sub> reduction, have not confirmed this linear regime at irradiance values ranging from 0.1 to 13.1 (Ballari et al. 2009; Hüsken et al. 2009; Murata et al. 2000). For each of these studies, the relationship can be described by a power law ( $R^2 > 0.98$  for each study). A linear relationship can only be assumed if measurements at low irradiance values are excluded. However, the number of points that must be excluded to obtain a  $R^2 > 0.95$  differs between studies, with the greatest value being 5 W m<sup>-2</sup>. As reported by Grant and Slusser (2005), mean daytime UV-A irradiance from the most northern (Fairbanks, Alaska, latitude 65.1 °N) and southern (Homestead, FL, latitude 25.4 °N) locations of a United States Department of Agriculture (USDA) climate monitoring network ranged from 10.5 to 22.3 W m<sup>-2</sup>. These values all fall in the area where the linear or nonlinear regime applies. However, in urban areas NO<sub>x</sub> ambient concentration follows a diurnal pattern associated with traffic. Urban background monitoring in London, UK, found that NO<sub>2</sub> peaks both in early morning and late afternoon and NO, which oxidizes quickly to NO<sub>2</sub> during daylight hours, peaks in early morning (Bigi and Harrison 2010). At these peaks, irradiance values are substantially lower than the mean daytime value. Improving the efficiency at which photocatalytic pavement mitigates atmospheric NO<sub>x</sub> pollution requires greater photo-activity and additional laboratory study at these low irradiance values.

*Laboratory-Scale Results Relative to Relative Humidity* Photocatalytic degradation of  $\text{NO}_x$  by pavement containing  $\text{TiO}_2$  occurs when  $\text{NO}_x$  is oxidized by  $\bullet\text{OH}$  (Fig. 9.2). These  $\bullet\text{OH}$  are generated by oxidation of a hydroxyl ion by an electron hole (Fig. 9.3), and water vapor serves as the original atmospheric source for these  $\text{OH}^-$  ions. While intuition would consequently suggest that increased humidity would result in increased  $\text{NO}_x$  reduction, the published literature suggests that the opposite is true. In addition to photocatalytic properties, materials containing  $\text{TiO}_2$  also exhibit photo-induced super-hydrophilicity (i.e., water on the surface has a contact angle of nearly  $0^\circ$ ) (Fujishima et al. 2008). Due to this unique property, adsorbed water vapor would then dispersedly spread across a surface, effectively blinding the passage of UV-A light across these photocatalytically active sites (Beeldens 2007). Data from photocatalytic pavement studies indicate a linear relationship with a negative slope (Table 9.4). One such plot of this seemingly linear, inverse correlation between higher relative humidity and  $\text{NO}_x$  degradation rate was developed by Husken et al. (2009). One noteworthy aspect of these laboratory-scale humidity studies is that they all occurred at room temperature, thereby allowing direct comparisons of these results according to relative humidity. In contrast, though, field applications could exhibit substantial variations in temperature which would then result in significant changes in the amount of water that can be present in the atmosphere. For field studies, specific humidity (the ratio of water vapor mass to total air mass) might consequently provide a better comparison. At  $20^\circ\text{C}$ , 10 and 80 % relative humidity (the extremes of laboratory data) convert to specific humidity values of 1.44 and  $11.6 \text{ g water (kg moist air)}^{-1}$  respectively (at 101.1 kPa). The intertwined importance of field temperature and humidity might then be important for those locations experiencing high specific humidity conditions. For example, four of the five locations identified with peak, urban  $\text{NO}_2$  concentrations (i.e., where as part of the rule making process, the USEPA used 2006–2008 data to determine ambient  $\text{NO}_2$  concentration in the form of the 2010-promulgated  $\text{NO}_2$  standard for counties within the United States, including Cook, IL, San Diego, CA, Los Angeles, CA, and Erie, NY) are all apt to experience high specific humidity conditions.

*Laboratory-Scale Results Relative to Temperature* The available laboratory-scale literature is vague in regards to the impact of temperature changes on  $\text{NO}_x$  photocatalytic performance. Assertions are general and in most cases state that  $\text{NO}_x$  reduction efficiency increases with higher temperature (Beeldens et al. 2011) and that only large differences in temperature (i.e., summer vs. winter) are significant (Dylla et al. 2011a, b). In addition to being vague, the literature also is contradictory and one source reports a decrease in oxidation rate with increased temperature (Chen and Chu 2011). Cold temperature climates, such as those that occur in northern and continental areas of the United States, may substantially be expected to experience lower photocatalytic rates. As with the preceding issue of ambient humidity, therefore, future full-scale evaluation of this temperature factor appears warranted.

*Laboratory-Scale Results Relative to  $\text{NO}_x$  Concentration* Photocatalytic laboratory-scale pavement studies display a clear negative correlation between inlet

NO<sub>x</sub> concentration and percent NO<sub>x</sub> reduction (Ballari et al. 2010, 2011; Hüsken and Brouwers 2008; Hüsken et al. 2009; Murata et al. 2000; Sikkema et al. 2012). Herrmann (1999) reports that reaction kinetics fall into a low-concentration first-order regime and a high-concentration zero-order regime. Under the zero-order regime, the reaction rate is controlled by reactions between adsorbed molecules. As applied to NO<sub>x</sub> reduction by photocatalytic pavements, the overall rate of NO<sub>x</sub> reduction will remain constant as input concentration increases, therefore the percent NO<sub>x</sub> reduction will decrease. As compared to the zero-order regime, the decrease in percent NO<sub>x</sub> reduction is dramatic within the first-order regime because the availability of active sites for decreases with increased concentration. Many photoreactor studies follow the ISO method and thereby assess NO<sub>x</sub> reduction at 1 ppmv. This value is an order of magnitude greater than even the highest value USEPA NO<sub>2</sub> standard and cannot be considered representative of environments where this technology may see application. Although photoreactor studies do evaluate the relationship between input concentration and NO<sub>x</sub> reduction, data points are often evenly distributed between high and low concentrations. As research moves to field application, it will need to be complemented by photoreactor studies that place focus on NO<sub>x</sub> reduction at low-concentration values.

*Laboratory-Scale Results Relative to NO<sub>2</sub>/NO<sub>x</sub> Ratio* Photocatalytic USEPA emissions estimates used for national trends assume a NO<sub>2</sub>/NO<sub>x</sub> ratio of 1 because NO is freely oxidized in the atmosphere (USEPA 2001). Within near-road environments assumed and measured NO<sub>2</sub>/NO<sub>x</sub> values for initial emissions in near-road environments fall between 0.05 and 0.31 (Wang et al. 2011). Photocatalytic pavement research has not established the relationship between NO<sub>2</sub>/NO<sub>x</sub> ratio and NO<sub>x</sub> reduction. Dylla et al. (2011a, b) asserts a negative correlation. The data set from Ballari et al. (2011) does not support this claim, listing NO<sub>x</sub> reduction of 34.9 and 36.5 at NO<sub>2</sub>/NO<sub>x</sub> ratios of 0 and 1 respectively. Settling these conflicts within the literature will require additional photoreactor studies that focus on near-road NO<sub>2</sub>/NO<sub>x</sub> ratios, which were identified in Wang et al. (2011).

*Laboratory-Scale Results Relative to Surface Contact Time [i.e., Laboratory-Reactor Flow Rate]* NO<sub>x</sub> reduction within a specific volume of test gas increases proportionally to the residence time over a photocatalytic surface because greater time exists for pollutants to absorb and be oxidized at active sites. As a result, literature demonstrates a clear negative correlation between NO<sub>x</sub> reduction and flow rate. In each case the relationship appears linear, but each publications supplies at most 3 data points (Ballari et al. 2010; Dylla et al. 2010; Hüsken and Brouwers 2008; Hüsken et al. 2009). Tested flow rates (1–9 L min<sup>-1</sup>) do not vary substantially from the 3 L min<sup>-1</sup> specified in the ISO (2007) standard. If the standard's reactor dimensions are also used, air velocity over the photocatalytic surface would measure 0.2 m s<sup>-1</sup>. Although considerable variation in wind velocity occurs within the field, in a relatively unobstructed environment, a reasonable expectation would set wind velocities at least an order of magnitude greater than the value specified by the standard (approximately 7 km h<sup>-1</sup>). Wind velocity of this magnitude would significantly reduce the effectiveness of field applications of photocatalytic pavements, especially if the wind carried pollutants in a direction perpendicular to the

roadway. Street canyons may represent an optimal location for photocatalytic pavements. The structures that border each side of these streets reduce natural ventilation and in many cases air pollution rises well above background concentrations (Vardoulakis et al. 2003). While this reduced airflow provides suitable site conditions for photocatalytic pavement, application of this technology within a street canyon must take into account decreased irradiance during periods when buildings obstruct sunlight.

## 9.8 Published Performance Results with Field-Scale TiO<sub>2</sub> Surface Evaluations

*Field-Scale General Testing Conditions and Results* Multiple field studies of photocatalytic pavements do exist but this documentation is significantly less extensive than that of the laboratory-scale research findings. Available field research can be categorized as those that compare photocatalytic and control sections, measure NO<sub>3</sub><sup>-</sup> deposition as evidence of photocatalytic activity, and attempt to model observations. These categories of field research are summarized in Tables 9.5 and 9.6.

*Field-Scale Results Evaluation* Table 9.5 summarizes the field studies that reported a percentile change in NO<sub>x</sub> concentration between control and photocatalytic sections. For the studies listed, the Borgo Palazzo reports (Italcementi 2009; Guerrini and Peccati 2007) provide the most detailed data. The proposed locations for the control and photocatalytic locations were monitored prior to the study, verifying that each section demonstrated similar characteristics for NO<sub>x</sub> pollution concentration and variation with time (Guerrini and Peccati 2007). During low irradiance hours, the observed concentrations at each section were not measurably different. For daylight hours, when both irradiance and traffic markedly increased, the change in concentration between the control and photocatalytic sections ranged from 20 to 66 %. The report also noted that soiling caused by construction traffic caused a decreased in photocatalytic activity.

In addition to general observations, which comport well with their laboratory data, the report from Guerrini and Peccati (2007) also provided new insights specific to field applications. As evidenced by the 1-h standard promulgated by the USEAP in (2010a, b, c) short-term exposure to NO<sub>x</sub> is particularly damaging to human health. The control location data displays peaks in NO<sub>x</sub> concentration that correspond with high traffic volumes. These peaks are substantially diminished in observations from the photocatalytic section. Furthermore values of percent difference for these instances are substantially above average reports, indicating that photocatalytic pavement is particularly effective as a tool to mitigate short-term spikes in air pollution. Laboratory data has established that photocatalytic pavements oxidize NO<sub>x</sub> when a small volume of NO<sub>x</sub> is passed over the pavement surface, but it is difficult to extrapolate this laboratory data to large areas.

**Table 9.5** Summary of published field-scale photoreactor tests and NO<sub>x</sub> change percentiles reported for paved surfaces containing TiO<sub>2</sub>

Location	Installation type	Pavement type	Surface area (m <sup>2</sup> )	Traffic volume	NO <sub>x</sub> conc. change (%)	Measurement approach for NO <sub>x</sub> change	Reference
Antwerp, Belgium	Parking lanes of urban road	Paving blocks	10,000		20	Avg.	Beeldens (2007, 2008)
Via Morandi, Segrate, Italy	Urban road	Thin mortar overlay	7,000	1,000 vehicles d <sup>-1</sup>	60	Max.	Italcementi (2006), Esstrocc (2008), Italcementi(2009)
					50	Avg.	
Calusco d'Adda, Bergamo, Italy	Industrial site road	Paving blocks	8,000		45	Avg.	Italcementi (2006, 2009)
Porpora Street, Milan, Italy	Road within tunnel	Concrete, TiO <sub>2</sub> ceiling paint	728 (concrete)	30,000 vehicles d <sup>-1</sup>	23	Min. UV irradiance	Italcementi (2006)
Borgo Palazzo, Bergamo, Italy	Urban	Paving blocks	7,000	400 cars h <sup>-1</sup>	40	Max.	Italcementi (2009)
					20	Min.	
					66	Max.	
					20	Min.	
Rue Jean Bleuzen, Vanves, France	Urban road	Concrete overlay	6,000	13,000 cars d <sup>-1</sup>	20	Min.	Italcementi (2009)
Milan, Italy	Urban road	Sprayed asphalt	4,000		49	Surface <i>in-situ</i> chamber test	Crispino and Vismara (2010)
					46		
					14		
Forli-Cesena, Italy	Urban road	Sprayed asphalt	2,500		49	Surface <i>in-situ</i> chamber test	Crispino and Vismara (2010)
Cantu and Monza, Italy	Urban road	Sprayed asphalt			50	Surface <i>in-situ</i> chamber test	Crispino and Vismara (2010)

(continued)

Table 9.5 (continued)

Location	Installation type	Pavement type	Surface area (m <sup>2</sup> )	Traffic volume	NO <sub>x</sub> conc. change (%)	Measurement approach for NO <sub>x</sub> change	Reference
Ferrara, Italy	Urban road	Sprayed asphalt	13,000		42	Uncertain	Crispino and Vismara (2010)
Vanves (near Paris), France	Urban road	Paving block	250 m length	14,000 cars d <sup>-1</sup>	40–50	Uncertain	Gignoux, et al. (2010)
		Thin bonded concrete overlay	250 m length	14,000 cars d <sup>-1</sup>	40–50		
St-Denis, France	Urban road	Concrete overlay	2,000		30 10	Measured respectively @ 2 and 20 m height	Rousseau et al. (2009)

**Table 9.6** Additional published field-scale test sites with paved surfaces containing TiO<sub>2</sub>

Location	Installation type	Pavement type	Surface area (m <sup>2</sup> )	Reference
Hengelo, Netherlands	Urban road	Paving blocks	750–1,200	Overman (2009)
Milan, Italy	Parking garage	Spray coating on asphalt	4,000	Crispino and Vismara (2010)
Forli-Cesena, Italy	Highway	Spray coating on asphalt	2,500	Crispino and Vismara (2010)
Cantù and Monza, Italy	Urban road	Spray coating on asphalt		Crispino and Vismara (2010)
Ferrara, Italy	Urban road	Spray coating on asphalt	13,000	Crispino and Vismara (2010)
Milan, Italy	Road within tunnel	Spray coating on asphalt	11,000	Crispino and Vismara (2010)
Multiple locations, Japan	Sidewalks and urban roads	Paving blocks	25,000	Beeldens and Cassar (2011)
Baton Rouge, LA, United States	Urban road	Spray coating on concrete		Hassan and Ok-eil (2011)
Den Hoek 3, Wijnegem, Belgium	Industrial site road	Concrete, two-lift construction		Beeldens and Boonen (2012)

Observations by Guerrini and Peccati (2007) begin to provide this extrapolation by providing measurements at 0.3 and 1.8 m. While measurements at the lower observation point indicate greater NO<sub>x</sub> reduction, even at 1.8 m the photocatalytic section values are on average 20 % lower than at the control location.

At the Baton Rouge site, NO<sub>x</sub> concentration was also measured simultaneously for a concrete section coated sprayed with a TiO<sub>2</sub> aqueous solution and a control section (Hassan and Ok-eil 2011). To compare the two sections, in one figure the authors reported total daily NO<sub>x</sub> reduction in units of ppb. For each data point, the reported value was greater than 1,000 ppb. The statistical approach used is difficult to understand and does not facilitate comparisons with other field or laboratory studies. Considering that this value is an order of magnitude greater than the USEPA 1-h standard, it is highly improbable that the statistic is the difference between locations. Regardless, the report does provide evidence that the pavement oxidizes NO<sub>x</sub> in field applications.

Hassan and Okiel (2011) work also draws correlations between environmental factors and NO<sub>x</sub> reduction observed. In concert with laboratory data, the authors observed that NO<sub>x</sub> reduction was negatively correlated to relative humidity and wind speed and positively correlated to irradiance. The aspect of wind direction warrants additional discussion. A number of full-scale test applications have involved street canyon situations where both natural ventilation is reduced and heavy traffic represents the major portion of NO<sub>x</sub> pollution. For the geometric configuration of a street canyon, longitudinal winds flush the area, preventing accumulation of NO<sub>x</sub>. Under transverse winds, the residence time of the pollutant



molecule is increased, permitting more time for photocatalytic oxidation and thereby resulting in increased percent  $\text{NO}_x$  reduction. Hassan and Okiel's findings indicated that  $\text{NO}_x$  reduction was higher when winds were in a longitudinal direction than when winds blew transversely. The result can be explained by the sites geometric conditions. Unlike anticipated applications, this study occurred in an area free from buildings which would prevent natural ventilation. Instead of flushing the surface and diminishing  $\text{NO}_x$  reduction, longitudinal winds are associated with the highest  $\text{NO}_x$  residence time at this particular location. Of particular interest, the authors found that transverse winds were especially negative. These winds carry the pollutant off of the pavement. Future stakeholders will need to take time to consider where the install pavements. As mentioned previously, a street canyon may be especially good location. Due to a lack of natural ventilation residence time of the pollutant above the photocatalytic surface is increased, enhancing photocatalytic oxidation.

Available field studies that compare photocatalytic and control sections of pavement highlight multiple factors that influence photocatalytic oxidation and the difficulty in providing data that provides sufficient evidence that will persuade stakeholders to adopt this technology. The reported studies are worthwhile, but additional work must provide more detailed data and data that is collected for a longer duration than that of the present work.

## 9.9 Overview of $\text{TiO}_2$ -Bearing Pavement Performance Factors

*Mix Design* Even if the most photocatalytically efficient photocatalyst is selected for use in a pavement application, substantial care needs to be taken in designing a mix and surface treatment in order to garner the maximum removal of ambient  $\text{NO}_x$ . In cementitious systems some pavements can be made photocatalytic with addition of a thin mortar placed on the surface or a non-photocatalytic component.  $\text{TiO}_2$  is added to either the cement or water components of the mortar mix. Laboratory research indicates that  $\text{TiO}_2$  is more homogeneously distributed, resulting in greater  $\text{NO}_x$  removal, when  $\text{TiO}_2$  is mixed with water (Hüsken et al. 2009). The researchers' quality control may not be achievable in ready-mix plants. It is possible a more consistent distribution of  $\text{TiO}_2$  in a photocatalytic mortar may be realized by tasking cement suppliers with the supplying photocatalytic cement. A second method to produce a cementitious photocatalytic pavement is to simply substitute photocatalytic cement in place of Type I cement when pouring concrete. With present technology, this practice is expensive. The cost can be reduced to an extent by using a two-lift pavement construction. Using widely accepted construction practice, a top layer could be reduced a 4 cm thickness (Hall et al. 2007). This technique does substantially increase costs (e.g., it requires two paving plants, two paving machines, and additional labor), but opens up new opportunities to use

lower-quality less expensive concrete in the bottom lift. Reportedly, these savings may be sufficient to offset the additional costs (Cable and Frentress 2004).

Another option to produce photocatalytic pavement is to simply spray a water-based  $\text{TiO}_2$  coating on an existing concrete surface (a process developed PURETI). This process may be economical and laboratory testing indicates that it produces similar levels of  $\text{NO}_x$  removal as a 5 %  $\text{TiO}_2$  content (by binder weight) mortar coating (Hassan et al. 2010b). It would seem probable that a water-based spray coating would dissipate over time with exposure to roadway environments. Simulated weathering did not confirm this expectation (Hassan et al. 2010b). However, given that coating pavement in this fashion is not common, additional laboratory research complemented by field testing is recommended.

*Surface Treatments* Surface treatments also can enable greater  $\text{NO}_x$  removal. Sand blasting and mixes in which aggregated sized less than 300  $\mu\text{m}$  in diameter were removed, treatments which both increase the pavement specific surface area, each increase  $\text{NO}_x$  removal (Dylla et al. 2010; Hüsken et al. 2009; Poon and Cheung 2007). A rapidly developing advancement holding substantial promise is the development of pervious photocatalytic concrete, which has approximately 6 times more surface area exposure to sunlight (Asadi et al. 2012). Under the same testing conditions, pervious concrete with a  $\text{TiO}_2$  depth of 2 inches or greater provided at minimum 11 % greater  $\text{NO}$  removal than non-pervious photocatalytic concrete.

*Pavement Aging and Soiling* As noted above, materials that interfere with catalytically active sites can cause decreases in  $\text{NO}_x$  reduction performance. Sufficient data do not exist to establish whether photocatalytic activity also decreases with pavement age. One report notes that activity lasts for a least 1 year, but acknowledges that longer duration tests are not complete (Cassar 2004). Theoretically, the pavement should maintain photocatalytic activity because  $\text{TiO}_2$  is not consumed by the  $\text{NO}_x$  reduction process. Furthermore, any abrasion that results from traffic should expose new  $\text{TiO}_2$  particles. Nevertheless, these assertions have not been verified with robust laboratory or field data. United States stakeholders will not progress with any large-scale projects unless research establishes that pavement age does not have a significant impact on activity (Berdahl and Akbari 2007).

*Wash-off and Surface Reactivity Regeneration* Efficient use of photocatalytic pavement requires strategies to address a decrease in  $\text{NO}_x$  reduction rate which appears likely to occur over time after the pavement is installed in a near-road environment. Researchers have suggested shearing airflow, surficial burning and stripping of chemi-sorbed carbon species, simulated rainfall, and road brushing and cleaning (Beeldens et al. 2011; Demeestere et al. 2008; Zhao and Yang 2003). Demeestere et al. (2008) found that airflow was a completely ineffective regeneration mechanism. While surface burning may be economical for some small-scale applications, it is impractical for pavements. Some sources claim that rain or surface washing is sufficient to regenerate photocatalytic activity (Beeldens 2008; Beeldens et al. 2011). One source noted the beneficial effect of rain, but still recommended surface washing at an interval of 2 months (Yu 2002). However, another researcher found that washing with a brush and deionized water did not cause a statistically

significant change (or increase) in the activity of photocatalytic paving blocks that had been partially deactivated by outdoor exposure in a near-road environment for a period of months (Yu 2003). The conflicts that exist in published literature point to a need for research that determines effective washing mechanisms to regenerate the photocatalytic activity of these pavements. This research could be expected to provide guidance on beneficially tailoring washing mechanisms to the factors that cause  $\text{NO}_x$  reduction rate reductions, as well as elucidating the required washing frequency to maintain desired  $\text{NO}_x$  reduction performance.

*Ecological Nitrate Wash-Off Impact Assessment* Although the  $\text{NO}_3^-$  product that results from  $\text{NO}_x$  PCO can be used as a plant nutrient, within the United States,  $\text{NO}_3^-$  is a water pollutant where excessive concentrations in aquatic environments causes eutrophication (The Cadmus Group 2009). Research on this possible unintended pollution is limited, but appears to suggest that concentrations are at levels that do not warrant ecological concern. One example calculation yielded a concentration of 5.3 mg/L  $\text{NO}_3^-$  (City Concept 2004). A second publication asserts that  $\text{NO}_3^-$  becomes bound inside the concrete matrix as calcium nitrate ( $\text{CaNO}_3$ ) and that dissolution into runoff water would be at a concentration 10 times less than the first pollution level (PICADA 2011). Another publication seemingly acknowledges that a water pollution problem is possible by proposing that  $\text{NO}_3^-$  can be extracted from runoff with a standard sewage plant (Husken et al. 2009). This solution may be practical in the authors' country of residence (the Netherlands) but within the United States, the majority of road runoff travels directly to surface water. Potential stakeholders require laboratory and field data that confirms  $\text{NO}_3^-$  in runoff will not exacerbate current water pollution problems (Berdahl and Akbari 2007).

*Pavement Blinding* The air-purifying effectiveness of photocatalytic pavements is hindered by reductions in  $\text{NO}_x$  PCO rate in comparison to the initial PCO rate (i.e., the rate when the pavement was installed). Pavement-specific literature attributes observed reductions to a decrease in irradiance reaching  $\text{TiO}_2$  caused by fine dust and organism adhesion (Beeldens et al. 2011) and interference from roadway contaminants such as dirt, de-icing salt, and motor oil (Dylla et al. 2011a, b). Other  $\text{TiO}_2$  studies attributed reductions in photocatalytic activity to blinding by the accumulation of oxidation products and intermediates (Beeldens 2008; Demeestere et al. 2008; Ibusuki and Takeuchi 1994; Zhao and Yang 2003). These observed reductions in  $\text{NO}_x$  reduction performance are significant. A study in which photocatalytic paving blocks set in an outdoor environment and then tested in a photoreactor at set intervals observed a 50 % decrease in removal efficiency over a 5-month period (Murata and Tobinai 2002). This decrease was attributed to dust and organism adhesion. A similar test reported a 36–78 % decrease in removal efficiency over 4 months and a 22–88 % decrease with 12 months of exposure (Yu 2003). After observing accumulation of particulate matter, oil, and chewing gum, and scratches on the pavement surface, the researchers credited a reduction in photocatalytic surface area as the cause for the decrease. To maximize the air-cleaning performance of photocatalytic concrete the primary factors that cause reductions in  $\text{NO}_x$  reduction must be identified. Dylla et al. (2011a, b) used

laboratory tests to determine the influence of dirt, de-icing salt, and motor oil on  $\text{NO}_x$  reduction. Each material significantly reduced oxidation efficiency, but the study did not compare the amount of material applied to test pieces to amounts observed on installed pavements. This study also did not assess whether the oxidized product ( $\text{NO}_3^-$ ) caused a reduction in oxidation efficiency. To ensure long-term performance of photocatalytic pavement, photoreactor studies must determine the primary factors that cause the field observed decrease in  $\text{NO}_x$  reduction performance.

*Field Assessment Observations* The comparative approach, which evaluates photocatalytic pavement with reference to a control section, requires significant expenses of both time and money. Furthermore, the data obtained can be difficult to evaluate since many complex factors influence both the concentration of  $\text{NO}_x$  pollution in an area and the effectiveness of photocatalytic oxidation. An alternative approach measures  $\text{NO}_3^-$  (the final product of  $\text{NO}_x$  photocatalytic oxidation) that accumulates on the surface of a pavement containing  $\text{TiO}_2$ . For photoreactor tests, this approach is described by an international standard (ISO 2007). Osborn et al. (2012) applied this approach in an effort evaluate to photocatalytic pavements in the field. A section of the pavement surface was isolated and soaked with water. This water was then analyzed for  $\text{NO}_3^-$  concentration. For a 7 day observation period,  $\text{NO}_3^-$  concentration on the photocatalytic section averaged  $0.04 \text{ mg l}^{-1}$  as N whereas the control section averaged  $0.003 \text{ mg l}^{-1}$  as N. While the method holds promise, deficiencies must be addressed in order to use this approach to evaluate photocatalytic pavements. Lingering concerns remain that this procedure may not remove all  $\text{NO}_3^-$  from the pavement surface and/or provide a washing effectiveness factor to account for the amount of  $\text{NO}_3^-$  that remains on the surface following use of the washing technique. Additionally, it is also unknown whether all  $\text{NO}_3^-$  originally oxidized on the photocatalytic surface remains at that location, or whether water is the only factor which can mobilize and remove this product.

*Field Modeling Efforts: Comparative field studies* and studies that measure products of  $\text{NO}_3^-$  on the photocatalytic surface represent worthwhile steps to validate photocatalytic pavements in the field. However, it is probable that the most useful tool to persuade future stakeholders will be models that can accurately predict  $\text{NO}_x$  concentration for photocatalytic and non-photocatalytic pavements. This type of model, would then serve as a tool by which a particular area could be evaluated as a candidate for photocatalytic pavement. After determining an expected decrease in  $\text{NO}_x$  concentration for the area, the stakeholders could then determine whether the cost of constructing a photocatalytic roadway outweighs other pollution mitigation options.

Based on field data Hassan and Okeil (2011) provide a nonlinear regression model governed variables of traffic volume, relative humidity, wind speed, temperature, and irradiance factors. Considering the multiple factors involved, the model's reported  $0.70 R^2$  value appears quite high. However application to other test locations is severely limited because upper boundaries are set at values of  $52 \text{ vehicle h}^{-1}$ ,  $2.7 \text{ ms}^{-1}$ , and  $20 \text{ }^\circ\text{C}$  for traffic volume, wind speed, and temperature respectively. Furthermore, the model does not distinguish whether the output result

is for the breathing height of an adult or directly at the pavement surface. Although a stakeholder will be regulated by the concentration recorded at a near-road or area-wide monitor, true concern is human welfare. Therefore, models should allow users to determine an estimate of concentration at the breathing heights of both children and adults.

A deliverable from the PICADA project provides a second option to predict the  $\text{NO}_x$  abatement effectiveness of photocatalytic materials (Barnpass et al. 2006). The fluid dynamics-based model was developed for photocatalytic coatings on buildings, but could be adapted for photocatalytic pavements. A reference scenario is developed with inputs of street and building dimensions, wind speed and direction, and average observed  $\text{NO}_x$  concentration. The scenario is then adjusted for photocatalytic oxidation of  $\text{NO}_x$  by inclusion of a deposition velocity variable. Incorporating all environmental factors that influence photocatalytic oxidation into a single variable severely limits the model. As noted by the authors this model should only be used as a “rough guide”.

Overman’s two-dimensional model is based on both fluid dynamics and kinetic equations for photocatalytic oxidation and atmospheric reactions (Overman 2009). The fluid dynamics components are governed by building and street geometry along with wind speed and direction. The photocatalytic oxidation kinetics component is based data obtained by Ballari et al. (2010) and includes inputs to account for irradiance, relative humidity, and  $\text{NO}$  and  $\text{NO}_2$  concentration. In addition, with input of  $\text{O}_3$ , the model accounts atmospheric photolysis of  $\text{NO}_2$  by UV irradiance. This model was applied to a road in Hengelo, Netherlands, with predicted reduction ranging from 2–6 to 10–19 % for  $\text{NO}$  and  $\text{NO}_2$  respectively. The two-dimensional component of the model allows for prediction of concentration at varied heights. However, wind direction is always assumed to be transverse. To account for other wind directions, a three-dimensional model would be required. Unfortunately, while calibrated against observations prior to photocatalytic pavement installation, a report is not available that assesses the predicted results after construction. This follow-up modeling effort would provide substantial.

## 9.10 Summary

Photocatalytic pavements have generated high interest from researchers and potential stakeholders. With an ever-increasingly stringent regulatory environment, it is highly probable that new approaches will be needed to mitigate  $\text{NO}_x$  pollution. Furthermore, while this review places focus on photocatalytic reactions with  $\text{NO}_x$ , benefits exist that cause oxidation of other pollutants detrimental to both the human welfare and the natural environment. At present, multiple areas exist in both laboratory and field research for which additional knowledge is needed. While the body of literature is substantial, future research must use strengthen the link between photoreactor and field studies, determine the environmental variables with the greatest impact on  $\text{NO}_x$  reduction, and develop models to facilitate selection of

roadways for which maximum NO<sub>x</sub> reduction can be achieved. While the field is novel and fascinating to study, the amount of work to be overcome is still significant. Multiple researchers are needed to address this problem and each will only be able to incrementally move the state of knowledge forward.

**Acknowledgement** The authors wish to thank the National Concrete Pavement Technology Center, the United States Department of Transportation, Essroc (Italcementi Group), and Lehigh Hanson, Inc. (Heidelberg Cement Group) for providing funding to pursue this review. In addition, the authors are grateful for in-kind services provided by the Missouri Department of Transportation and Fred Weber, Inc.

## References

- Amadelli, R., Cassar, L., & Pepe, C. (2004). U.S. Patent No. 6,824,826.
- Ancora, R., Borsa, M., & Cassar, L. (2012). U.S. Patent No. 8,092,586.
- Asadi, S., Hassan, M. M., Keavern, J. T., & Rupnow, T. (2012). Development of Photocatalytic Pervious Concrete Pavement for Air and Stormwater Improvements. *Transportation Research Record*.
- Ballari, M. M., Hunger, M., Hüsken, G., & Brouwers, H. J. H. (2009). Heterogeneous photocatalysis applied to concrete pavement for air remediation. *Nanotechnology in Construction 3, Proceedings*, (pp. 409–414).
- Ballari, M. M., Hunger, M., Hüsken, G., & Brouwers, H. J. H. (2010). NO<sub>x</sub> photocatalytic degradation employing concrete pavement containing titanium dioxide. *Applied Catalysis B-Environmental*, 95(3–4), 245–254. doi:10.1016/j.apcatb.2010.01.002.
- Ballari, M. M., Yu, Q. L., & Brouwers, H. J. H. (2011). Experimental study of the NO and NO<sub>2</sub> degradation by photocatalytically active concrete. *Catalysis Today*, 161(1), 175–180. doi:10.1016/j.cattod.2010.09.028.
- Barmpass, P., Moussiopoulos, N., & Vlahocostas, C. (2006). De-pollution prediction tool and integrated economic assessment *PICADA Project*.
- Beeldens, A. (2007, October 8–9). *Air purification by road materials: results of the test project in antwerp*. Paper presented at the International RILEM Symposium on Photocatalysis, Environment and Construction Materials—TDP 2007, Florence, Italy.
- Beeldens, A. (2008). *Air purification by pavement blocks: final results of the research at the BRRC*. Slovenia: Ljubljana.
- Beeldens, A., & Boonen, E. (2012). *A double layered photocatalytic concrete pavement: a durable application with air-purifying properties*. Paper presented at the 10th International Conference on Concrete Pavements, Quebec City, Canada.
- Beeldens, A., Cassar, L., & Murata, Y. (2011). Applications of TiO<sub>2</sub> photocatalysis for air purification. In Y. Ohama & D. Van Gemert (Eds.), *Application of titanium dioxide photocatalysis to construction materials* (1st ed.). Berlin: Springer
- Berdahl, P., & Akbari, H. (2007). Evaluation of Titanium Dioxide as a Photocatalyst for Removing Air Pollutants.
- Bigi, A., & Harrison, R. M. (2010). Analysis of the air pollution climate at a central urban background site. *Atmospheric Environment*, 44(16), 2004–2012. doi:10.1016/j.atmosenv.2010.02.028.
- Brauer, M., Hoek, G., Van Vliet, P., Meliefste, K., Fischer, P. H., Wijga, A. et al. (2002). Air pollution from traffic and the development of respiratory infections and asthmatic and allergic symptoms in children. *American Journal of Respiratory and Critical Care Medicine*, 166(8), 1092–1098. doi:10.1164/rccm.200108-007OC.

- Brunekreef, B., Janssen, N. A. H., deHartog, J., Harssema, H., Knappe, M., & vanVliet, P. (1997). Air pollution from truck traffic and lung function in children living near motorways. *Epidemiology*, 8(3), 298–303.
- Cable, J. K., & Frentress, D. P. (2004). *Two-Life Portland Cement Concrete Pavements to Meet Public Needs*. Ames, IA: Center for Portland Cement Concrete Pavement Technology.
- Carp, O., Huisman, C. L., & Reller, A. (2004). Photoinduced reactivity of titanium dioxide. [Review]. *Progress in Solid State Chemistry*, 32(1–2), 33–177. doi:10.1016/j.progsolidstchem.2004.08.001.
- Cassar, L., & Pepe, C. (2000). U.S. Patent No. 6,117,229.
- Cassar, L., & Pepe, C. (2002a). U.S. Patent No. 6,406,536.
- Cassar, L., & Pepe, C. (2002b). U.S. Patent No. 6,409,821.
- Cassar, L. (2004). Photocatalysis of cementitious materials: Clean buildings and clean air. [Article]. *MRS Bulletin*, 29(5), 328–331.
- Cassar, L., & Pepe, C. (2010). European Patent No. 1,600,430.
- Cassar, L., Cucitore, R., & Pepe, C. (2011). U.S. Patent No. 7,960,042.
- Chen, M., & Chu, J. W. (2011). NO(x) photocatalytic degradation on active concrete road surface— from experiment to real-scale application. *Journal of Cleaner Production*, 19(11), 1266–1272. doi:10.1016/j.jclepro.2011.03.001.
- City Concept. (2004). D-NOx: The concrete paving block for atmospheric purification. Tessenderlo, Belgium.
- Clean Air Act (2008). 42 U.S.C. § 7401 et seq.
- Control of emissions from new and in-use highway vehicles and engines, 40 C.F.R. pt. 86.007-11 (2008).
- Crispino, M., & Vismara, S. (2010). *Innovative Photocatalytic Pavements Presentation at International Sustainable Pavements Workshop*. VA: Airie.
- Cucitore, R., Cangiano, S., & Cassar, L. (2011). U.S. Patent No. 8,039,100.
- Dalton, J. S., Janes, P. A., Jones, N. G., Nicholson, J. A., Hallam, K. R., & Allen, G. C. (2002). Photocatalytic oxidation of NOx gases using TiO2: a surface spectroscopic approach. *Environmental Pollution*, 120(2), 415–422. doi:10.1016/s0269-7491(02)00107-0.
- Demeestere, K., Dewulf, J., De Witte, B., Beeldens, A., & Van Langenhove, H. (2008). Heterogeneous photocatalytic removal of toluene from air on building materials enriched with TiO2. *Building and Environment*, 43(4), 406–414. doi:10.1016/j.buildenv.2007.01.016.
- Dylla, H., Hassan, M. M., Mohammad, L. N., Rupnow, T., & Wright, E. (2010). Evaluation of environmental effectiveness of titanium dioxide photocatalyst coating for concrete pavement. *Transportation Research Record: Journal of the Transportation Research Board*, 2164(-1), 46–51. doi:10.3141/2164-06.
- Dylla, H., Hassan, M. M., Schmitt, M., Rupnow, T., & Mohammad, L. N. (2011a). Laboratory Investigation of the Effect of Mixed Nitrogen Dioxide and Nitrogen Oxide Gases on Titanium Dioxide Photocatalytic Efficiency in Concrete Pavements. *Journal of Materials in Civil Engineering*, 23(7), 1087–1093. doi:10.1061/(asce)mt.1943-5533.0000248.
- Dylla, H., Hassan, M. M., Schmitt, M., Rupnow, T., Mohammad, L. N., & Wright, E. (2011). *Effects of roadway contaminants on titanium dioxide photodegradation of NOx*. Paper presented at the Transportation Research Board 90th Annual Meeting, Washington, DC.
- Essroc. (2008). LEED-NC<sup>®</sup> 2.2 Guide: Using TX Arca<sup>®</sup> and TX Aria<sup>®</sup> Photocatalytic Cements for New Construction and Major Renovations Nazareth, PA.
- FHWA (2011). Our Nation's Highways: Highway Finance Data Collection, Office of Highway Policy Information, Federal Highway Administration (FHWA), Washington, D.C. Available online: <https://www.fhwa.dot.gov/policyinformation/pubs/hf/pl11028/chapter1.cfm>. Accessed 28 Aug 2014.
- Finkelstein, M. M., Jerrett, M., & Sears, M. R. (2004). Traffic air pollution and mortality rate advancement periods. *American Journal of Epidemiology*, 160(2), 173–177. doi:10.1093/Aje/Kwh181.
- Frank, S. N., & Bard, A. J. (1977). Heterogeneous Photocatalytic Oxidation of Cyanide Ion in Aqueous-Solutions at TiO2 Powder. *Journal of the American Chemical Society*, 99(1), 303–304.



- Fujishima, A., Hashimoto, K., & Watanabe, T. (1999). *TiO<sub>2</sub> photo catalysis: fundamentals and applications*. Tokyo: BKC Inc.
- Fujishima, A., & Honda, K. (1972). Electrochemical photolysis of water at a semiconductor electrode. [doi:[10.1038/238037a0](https://doi.org/10.1038/238037a0)]. *Nature*, 238(5358), 37–38.
- Fujishima, A., Rao, T. N., & Tryk, D. A. (2000). Titanium dioxide photocatalysis. *Journal of Photochemistry and Photobiology C: Photochemistry Reviews*, 1(1), 1–21. doi:[10.1016/s1389-5567\(00\)00002-2](https://doi.org/10.1016/s1389-5567(00)00002-2).
- Fujishima, A., & Zhang, X. T. (2006). Titanium dioxide photocatalysis: present situation and future approaches. *Comptes Rendus Chimie*, 9(5–6), 750–760. doi:[10.1016/j.crci.2005.02.055](https://doi.org/10.1016/j.crci.2005.02.055).
- Fujishima, A., Zhang, X. T., & Tryk, D. A. (2008). TiO<sub>2</sub> photocatalysis and related surface phenomena. [Review]. *Surface Science Reports*, 63(12), 515–582. doi:[10.1016/j.surfrep.2008.10.001](https://doi.org/10.1016/j.surfrep.2008.10.001).
- Garshick, E., Laden, F., Hart, J. E., & Caron, A. (2003). Residence near a major road and respiratory symptoms in US veterans. *Epidemiology*, 14(6), 728–736. doi:[10.1097/01.ede.0000082045.50073.66](https://doi.org/10.1097/01.ede.0000082045.50073.66).
- Gignoux, L., Chirstory, J. P., & Petit, J. F. (2010). *Concrete roadways and air quality—Assessment of trials in Vanes in the hear of the Paris region*. Paper presented at the 12th International Symposium on Concrete Raods, Sevilla Spain.
- Goodeve, C. F., & Kitchener, J. A. (1938). Photosensitisation by titanium dioxide. *Transactions of the Faraday Society*, 34, 570–579.
- Grant, R. H., & Slusser, J. R. (2005). Estimation of ultraviolet-A irradiance from measurements of 368-nm spectral irradiance. *Journal of Atmospheric and Oceanic Technology*, 22(12), 1853–1863. doi:[10.1175/jtech1823.1](https://doi.org/10.1175/jtech1823.1).
- Guerrini, G. L. (2012). U.S. Patent No. 20,120,270,721.
- Guerrini, G. L., & Peccati, E. (2007, October 8–9). *Photocatalytic cementitious roads for depollution*. Paper presented at the International RILEM Symposium on Photocatalysis, Environment and Construction Materials—TDP 2007, Florence, Italy.
- Hall, K., Dawood, D., Vanikar, S., Tally, R., Cackler, T., Correa, A. et al. (2007). Long-Life Concrete PAvements in Europe and Canda: Federal Highway Administration.
- Hashimoto, K., Irie, H., & Fujishima, A. (2005). TiO<sub>2</sub> photocatalysis: A historical overview and future prospects. *Japanese Journal of Applied Physics, Part 1: Regular Papers and Short Notes and Review Papers*, 44(12), 8269–8285.
- Hassan, M. M., Dylla, H., Mohammad, L. N., & Rupnow, T. (2010a, April). *Durability of titanium dioxide photocatalytic layer for pavement surfaces*. Paper presented at the 46th Annual Conference of the Associated Schools of Construction, Boston, Massachusetts.
- Hassan, M. M., Dylla, H., Mohammad, L. N., & Rupnow, T. (2010b). *Effect of application methods on the effectiveness of titanium dioxide as a photocatalyst compound to concrete pavement*. Paper presented at the Transportation Research Board 89th Annual Meeting, Washington, D.C.
- Hassan, M. M., Dylla, H., Mohammad, L. N., & Rupnow, T. (2010b). Evaluation of the durability of titanium dioxide photocatalyst coating for concrete pavement. *Construction and Building Materials*, 24(8), 1456–1461. doi:[10.1016/j.conbuildmat.2010.01.009](https://doi.org/10.1016/j.conbuildmat.2010.01.009).
- Hassan, M. M., & Okeil, A. (2011). *Field and laboratory investigation of photocatalytic pavements: Final report*. Baton Rouge, LA: Gulf Coast REsearch Center for Evacuation and Transportation Resiliency.
- Herrmann, J. M. (1999). Heterogeneous photocatalysis: fundamentals and applications to the removal of various types of aqueous pollutants. *Catalysis Today*, 53(1), 115–129.
- Herrmann, J. M., Péruchon, L., Puzenat, E., & Guillard, C. (2007, October 8–9). *Photocatalysis: From fundamentals to self-cleaning glass applications*. Paper presented at the International RILEM Symposium on Photocatalysis, Environment and Construction Materials—TDP 2007, Florence, Italy.
- Hüsken, G., & Brouwers, H. J. H. (2008, June 16–20). *Air purification by cementitious materials: Evaluation of air purifying properties*. Paper presented at the International Conference on Construction and Building Technology, Kuala Lumpur, Malaysia.



- Husken, G., Hunger, M., & Brouwers, H. J. H. (2009). Experimental study of photocatalytic concrete products for air purification. *Building and Environment*, 44(12), 2463–2474. doi:10.1016/j.buildenv.2009.04.010.
- Hüsken, G., Hunger, M., & Brouwers, H. J. H. (2009). Experimental study of photocatalytic concrete products for air purification. *Building and Environment*, 44(12), 2463–2474. doi:10.1016/j.buildenv.2009.04.010.
- Hwang, S., Lee, M. C., & Choi, W. (2003). Highly enhanced photocatalytic oxidation of CO on titania deposited with Pt nanoparticles: kinetics and mechanism. *Applied Catalysis B-Environmental*, 46(1), 49–63. doi:10.1016/s0926-3373(03)00162-0.
- Ibusuki, T., & Takeuchi, K. (1994). Removal of low concentration nitrogen-oxides through photo assisted heterogeneous catalysis. *Journal of Molecular Catalysis*, 88(1), 93–102. doi:10.1016/0304-5102(93)e0247-e.
- ISO. (2007). Fine ceramics (advanced ceramics, advanced technical ceramics)—Test method for air-purification performance of semiconducting photocatalytic materials—Part 1: Removal of nitric oxide (Vol. 22197-1:2007): ISO.
- Italcementi. (2006). TX Active by Italcementi. Bergamo, Italy.
- Italcementi. (2009). *TX active, The photocatalytic active principle*, Technical report. Bergamo, Italy.
- Jacoby, W. A., Blake, D. M., Noble, R. D., & Koval, C. A. (1995). Kinetics of the oxidation of trichloroethylene in air via heterogeneous photocatalysis. *Journal of Catalysis*, 157(1), 87–96. doi:10.1006/jcat.1995.1270.
- JIS. (2010). *Fine ceramics (advanced ceramics, advanced technical ceramics)—Test method for air-purification performance of semiconducting photocatalytic materials—Part 1: Removal of nitric oxide*. (JIS R 1701-1:2010). Tokyo, Japan.
- Kat, S., & Masou, F. (1964). *Kogyo Kagaku Zasshi*, 67, 1136.
- Keidel, E. (1929). *Farben-zeitung*, 34, 1242.
- Kim, J. J., Smorodinsky, S., Lipsett, M., Singer, B. C., Hodgson, A. T., & Ostro, B. (2004). Traffic-related air pollution near busy roads—The East Bay children’s respiratory health study. *American Journal of Respiratory and Critical Care Medicine*, 170(5), 520–526. doi:10.1164/rccm.200403-2810C.
- Kumar, P., Dushenkov, V., Motto, H., and Raskin, I. (1995). Phytoextraction—the use of plants to remove heavy-metals from soils. *Environmental Science and Technology*, 29(5), 1232–1238. doi:10.1021/es00005a014.
- Lim, T. H., Jeong, S. M., Kim, S. D., & Gyenis, J. (2000). Photocatalytic decomposition of NO by TiO<sub>2</sub> particles. *Journal of Photochemistry and Photobiology a-Chemistry*, 134(3), 209–217. doi:10.1016/s1010-6030(00)00265-3.
- Murata, Y., Kamitani, K., & Takeuchi, K. (2000). *Air purifying blocks based on photocatalysis*. Paper presented at the Japan Interlocking BLock Pavement Engineering Association World Congress 2000, Tokyo, Japan.
- Murata, Y., Tawara, H., Obata, H., & Murata, K. (2003). European Patent No. 0,786,283.
- Murata, Y., & Tobinai, K. (2002). Influence of various factors on NO<sub>x</sub> removal performance of permeable interlocking block based on photocatalysis. *Journal of Structural and Construction Engineering (Transactions of AIJ)*, (555), 9–15.
- Murrini, L., Conde, F., Leyva, G., & Litter, M. I. (2008). Photocatalytic reduction of Pb(II) over TiO<sub>2</sub> (2): New insights on the effect of different electron donors. *Applied Catalysis B-Environmental*, 84(3–4), 563–569. doi:10.1016/j.apcatb.2008.05.012
- Obee, T. N., and Brown, R. T. (1995). TiO<sub>2</sub> Photocatalysis for indoor air applications—effects of humidity and trace contaminant levels on the oxidation rates of formaldehyde, toluene, and 1,3-butadiene. *Environmental Science and Technology*, 29(5), 1223–1231. doi:10.1021/es00005a013.
- Ohama, Y., & Van Gemert, D. (2011). Introduction. In Y. Ohama & D. Van Gemert (Eds.), *Application of titanium dioxide photocatalysis to construction materials* (1st ed.). Berlin: Springer.

- Ohno, T., Sarukawa, K., Tokieda, K., & Matsumura, M. (2001). Morphology of a TiO<sub>2</sub> photocatalyst (Degussa, P-25) consisting of anatase and rutile crystalline phases. *Journal of Catalysis*, 203(1), 82–86. doi:10.1006/jcat.2001.3316.
- Osborn, D., Hassan, M. M., & Dylla, H. (2012). Quantification of NO<sub>x</sub> reduction via Nitrate accumulation on a TiO<sub>2</sub> photocatalytic concrete pavement. *Transportation Research Record* 12-1832.
- Overman, H. T. J. (2009). *Simulation model for NO<sub>x</sub> distributions in a street canyon with air purifying pavement*. (Master: Civil Engineering and Management), University of Twente, Enschede, Netherlands.
- Paz, Y. (2010). Application of TiO<sub>2</sub> photocatalysis for air treatment: Patents' overview. *Applied Catalysis B-Environmental*, 99(3–4), 448–460. doi:10.1016/j.apcatb.2010.05.011.
- Peral, J., & Ollis, D. F. (1992). Heterogeneous photocatalytic oxidation of gas-phase organics for air purification—acetone, 1-butanol, butyraldehyde, formaldehyde, and meta-xylene oxidation. *Journal of Catalysis*, 136(2), 554–565. doi:10.1016/0021-9517(92)90085-v.
- PICADA. (2011). Guideline for end-users, GROWTH Project GRD1-2001-40449.
- Poon, C. S., & Cheung, E. (2007). No removal efficiency of photocatalytic paving blocks prepared with recycled materials. *Construction and Building Materials*, 21(8), 1746–1753. doi:10.1016/j.conbuildmat.2006.05.018.
- Primary National Ambient Air Quality Standards for Nitrogen Dioxide: Final Rule, 75 Fed. Reg. 6474 (2010) (to be codified at 40 C.F.R. pts. 50 and 58).
- Rousseau, P., Drouadaine, I., & Mazé, M. (2009, May-June). Le procédé NOxer® : du développement aux mesures de dépollution sur site. *Revue générale des routes et de l'aménagement*.
- Sclafani, A., & Herrmann, J. M. (1996). Comparison of the photoelectronic and photocatalytic activities of various anatase and rutile forms of titania in pure liquid organic phases and in aqueous solutions. *Journal of Physical Chemistry*, 100(32), 13655–13661. doi:10.1021/jp9533584.
- Sikkema, J. K. (2013). *Photocatalytic degradation of NO<sub>x</sub> by concrete pavement containing titanium dioxide*. (Unpublished doctoral dissertation). Iowa State University, Ames, IA.
- Sikkema, J. K., Alleman, J. E., Ong, S. K., Koziel, J. A., Taylor, P. C., & Bai, H. (2012, September 18–21). *Photocatalytic concrete pavements: Decrease in NO<sub>x</sub> oxidation due to reaction product blinding*. Paper presented at the International Conference on Long-Life Concrete Pavement-2012, Seattle, Washington.
- Strini, A., Cassese, S., & Schiavi, L. (2005). Measurement of benzene, toluene, ethylbenzene and o-xylene gas phase photodegradation by titanium dioxide dispersed in cementitious materials using a mixed flow reactor. *Applied Catalysis B-Environmental*, 61(1–2), 90–97. doi:10.1016/j.apcatb.2005.04.009.
- The Cadmus Group, I. (2009). *Nutrient Control Design Manual: State of Technology Review Report*.
- Thoma, E. D., Shores, R. C., Isakov, V., & Baldauf, R. W. (2008). Characterization of near-road pollutant gradients using path-integrated optical remote sensing. *Journal of the Air and Waste Management Association*, 58(7), 879–890. doi:10.3155/1047-3289.58.7.879.
- Tompkins, D. T., Lawnicki, B. J., Zeltner, W. A., & Anderson, M. A. (2005). Evaluation of photocatalysis for gas-phase air cleaning—Part 1: Process, technical, and sizing considerations. *Ashrae Transactions* 2005, Vol 111, Pt 2, 111, 60–84.
- UNI. (2007). *UNI 1247:2007*. Italy: Milan.
- USEPA. (1999). *Technical bulletin: Nitrogen oxides (NO<sub>x</sub>), why and how they are controlled*. (EPA-456/F-99-006R). Research Triangle Park, NC.
- USEPA. (2001). *National air quality and emissions trends report, 1999*. (EPA 454/R-01-004). Washington, D.C.
- USEPA. (2007). *Summary of current and historical light-duty vehicle emission standards*. Washington, D.C. Retrieved from <http://www.epa.gov/greenvehicles/detailedchart.pdf>.
- USEPA. (2008). *Average annual emissions and fuel consumption for gasoline-fueled passenger cars and light trucks*. (EPA420-F-08-024). Washington, D.C.: Retrieved from <http://www.epa.gov/otaq/consumer/420f08024.pdf>.
- USEPA. (2009). *National primary drinking water regulations*. (EPA 816-F-09-004). Washington, D.C.

- USEPA. (2010a). *Design values (Average 1-H 98th Percentiles over 3 Years) by county for nitrogen dioxide*. Research Triangle Park, NC: Retrieved from [http://www.epa.gov/oaqps001/nitrogenoxides/pdfs/NO2\\_final\\_designvalues\\_0608\\_Jan22.pdf](http://www.epa.gov/oaqps001/nitrogenoxides/pdfs/NO2_final_designvalues_0608_Jan22.pdf).
- USEPA. (2010b). *Fact sheet: final revisions to the national ambient air quality standards for nitrogen dioxide*. Research Triangle Park, NC: Retrieved from <http://www.epa.gov/oaqps001/nitrogenoxides/pdfs/20100122fs.pdf>.
- USEPA. (2010c). *Final regulatory impact analysis (RIA) for the NO<sub>2</sub> national ambient Air quality standards (NAAQS)*. Research Triangle Park, NC: Retrieved from <http://www.epa.gov/ttnecas1/regdata/RIAs/FinalNO2RIAfulldocument.pdf>.
- Vardoulakis, S., Fisher, B. E. A., Pericleous, K., & Gonzalez-Flesca, N. (2003). Modelling air quality in street canyons: a review. *Atmospheric Environment*, 37(2), 155–182. doi:10.1016/s1352-2310(02)00857-9.
- Wang, Y. J., DenBleyker, A., McDonald-Buller, E., Allen, D., & Zhang, K. M. (2011). Modeling the chemical evolution of nitrogen oxides near roadways. *Atmospheric Environment*, 45(1), 43–52. doi:10.1016/j.atmosenv.2010.09.050.
- Watts, M. J., & Cooper, A. T. (2008). Photocatalysis of 4-chlorophenol mediated by TiO<sub>2</sub> fixed to concrete surfaces. *Solar Energy*, 82(3), 206–211. doi:10.1016/j.solener.2007.08.001.
- Yu, J. C. (2002). *Ambient Air Treatment by Titanium Dioxide (TiO<sub>2</sub>) Based Photocatalyst in Hong Kong*.
- Yu, J. C. (2003). *Deactivation and Regeneration of Environmentally Exposed Titanium Dioxide (TiO<sub>2</sub>) Based Products Hong Kong*.
- Zhao, Y., Han, J., Shao, Y., & Feng, Y. (2009). Simultaneous SO<sub>2</sub> and NO removal from flue gas based on TiO<sub>2</sub> photocatalytic oxidation. *Environmental Technology*, 30(14), 1555–1563. doi:10.1080/09593330903313786.
- Zhao, J., & Yang, X. D. (2003). Photocatalytic oxidation for indoor air purification: a literature review. *Building and Environment*, 38(5), 645–654. doi:10.1016/s0360-1323(02)00212-3.

# Chapter 10

## Warm Mix Asphalt

Martins Zaumanis

**Abstract** Warm Mix Asphalt (WMA) technologies have potential to reduce the application temperature of Hot Mix Asphalt (HMA) and improve workability without compromising the performance of asphalt pavement. This promises various benefits, e.g. a reduction in greenhouse gas emissions, decreased energy consumption and costs, improved working conditions, better compaction, extended paving season, higher reclaimed asphalt content, earlier opening to traffic, etc. These benefits as well as the potential concerns are discussed in this chapter. Mix design considerations and possible specializations of WMA technologies are summarized. Different WMA production technologies are reviewed with an emphasis on practical applications.

### 10.1 Introduction

The concept of using lower temperatures to produce asphalt mixes dates back to the 1950s (Vaitkus et al. 2009). The modern WMA was born in Germany in the mid-1990s with the use of waxes as viscosity modifiers for mastic asphalt. Since then a variety of new technologies has been developed in Europe and in 2002 WMA was introduced in the US (D'Angelo et al. 2008). During the last decade the US has become the world leader in implementing WMA technologies (EAPA 2013). Here since 2009 the WMA use has increased by 416 % and in 2012 78.7 million tonnes or 26 % of asphalt mixtures were produced by applying one of the warm mix asphalt technologies (Hansen and Copeland 2013). There are many reasons for such advance, the most important of which are reduced energy consumption, limited emissions, and, perhaps most importantly, improvement in asphalt workability at similar or even lower temperatures compared to HMA.

---

M. Zaumanis (✉)

Worcester Polytechnic Institute, Institute Road 100, Kaven Hall, Worcester, MA 01609, USA  
e-mail: jeckabs@gmail.com

In Europe the use of WMA has not become as widespread as in the US and currently only a small portion of asphalt pavements is produced as WMA (EAPA 2012). European countries use WMA more as a niche product for special applications rather than a replacement for conventional HMA. The specific applications often include projects that require improved workability, fast opening times (airfields, night work, junctions), and environmentally critical areas.

The different products fall into one or more of the three general WMA production techniques:

- Foaming technologies, including mechanical foaming and water bearing minerals.
- Organic or wax technologies.
- Chemical additives.

Some of these technologies involve permanent or temporary altering of the binder properties, such as reducing the viscosity. Others rely on improving the coating of aggregates by chemically improving the adhesion between binder and aggregates or introducing surface active agents to improve the aggregate wettability. In the US foaming technologies with the use of nozzles are the most popular among the WMA products accounting for 88 % of the market (Hansen and Copeland 2013). This is likely due to their satisfactory performance and the lowest costs among WMA technologies.

## 10.2 Overview of WMA

Warm Mix Asphalt technologies use technological advances that allow a reduction in the mixture temperature while improving the workability and compaction when compared to hot mix asphalt. Besides these come multiple other benefits over traditional hot-mix asphalt that, along with some potential concerns, are summarized in this Section in four categories:

- Paving.
- Production.
- Environmental.
- Economic.

### 10.2.1 Paving

At a given temperature WMA technologies improve workability when compared with hot mix asphalt. Thus they are often used as a compaction aid, to provide the necessary density of stiff mixes. Typically WMA has better workability compared to HMA even at lower temperature. In this case the reduced difference between mix

and ambient temperature means the mixture is cooling slower thus providing longer window for compaction compared to HMA. As a result, WMA technologies are often used as compaction aids to ensure cold weather paving, which can extend the paving season or enable night-time and high altitude paving.

Similar to cold weather paving, longer haul distances are possible because mixtures can be compacted at lower temperature. Construction sites a long distance from the plant can be served without losing workability, when WMA technology is used to produce mixtures at traditional HMA temperatures. This means expanded market areas, decreased mobilization cost and accessibility to large urban areas.

Finally, WMA technologies can reduce pavement cooling time if paved at lower temperature. There are reports (Lee 2008) of opening the road to traffic as soon as 2 h after the paving operation. This can be particularly useful at airports, where the time window for construction can be very tight. In a reconstruction project at Frankfurt airport, the existing concrete runway was successfully repaved using WMA and working at night between 10:30 pm and 6:00 am, with the runway temperatures at the opening less than 80 °C (Drüschner 2009).

Software “Multi-Cool” has been developed at the University of Minnesota for the University of California (NAPA 2014). It allows for calculation of optimum paving temperature and the available compaction window based on the environmental conditions and asphalt mixture temperature. It is a useful tool for planning WMA application, especially for cold weather paving.

### ***10.2.2 Production***

WMA can be produced with existing asphalt plants by retrofitting the required equipment for a particular technology. One major advantage of production using WMA technologies is the potential to increase the Reclaimed Asphalt Pavement (RAP) and Reclaimed Asphalt Shingles (RAS) content in mixture (Bonaquist 2011a; Zaumanis and Mallick 2013; Kristjansdottir 2007). Since mixture workability is increased even at reduced temperature, less superheating is required for virgin aggregates when adding RAP and RAS. The lower production temperature also reduces the undesirable aging of the already stiff RAP binder.

Some concerns have been recognized for production of WMA as well:

- Residual moisture left from foaming technologies can increase moisture susceptibility (Bonaquist 2011a).
- When RAS and RAP is used in production, the temperature must be sufficient to activate the hard, aged binder (Bonaquist 2011a).
- Plant burners may need tuning to account for lower output due to reduced temperature. This will allow an increase in burner efficiency, reduced fuel consumption, reduced stack emissions and avoiding mixture contamination with liquid fuel. (Harder 2008; West et al. 2014)

- Because of the lower production temperature, the aggregate exposure to the flame in the heating drum can potentially be reduced thus increasing production rate. However, this should be done with caution, because insufficient time of exposure to heat may leave residual moisture in the aggregates and result in insufficient coating of the aggregates with binder.
- The lowered temperatures during production of WMA can lead to condensation in the baghouse which can result in damp baghouse fines and corrosion. The proposed methods to keep the baghouse temperatures high enough are described in details by Prowell et al. (2012) and include:
  - Preheating the baghouse.
  - Insulating the baghouse and ductwork.
  - Removing veiling flights.
  - Increasing air flow by opening the exhaust damper.
  - Adding a duct heater.
  - Installing a variable frequency drive on drum drive or slinger.
  - Ensuring complete aggregate drying.
  - Insulating the dryer shell.

### ***10.2.3 Environmental Benefits***

The reduction of production temperature when using WMA and the increased workability of the mixtures provide a potential for significant reduction in energy consumption resulting in lower emissions and reduced carbon footprint of asphalt industry. Reports on the environmental benefits are summarized here.

#### **10.2.3.1 Energy Use**

One of the most significant benefits of WMA is the decrease in energy use. Young (2007) has approximated that for every 6 °C reduction in temperature, fuel consumption is reduced by 2–3 %. Figure 10.1 demonstrates results of thermodynamics calculation of energy consumption based on production temperature and another critical parameter, aggregate moisture content. The results of these calculations are confirmed by various practical studies. A scanning report of European WMA production sites demonstrated a 20 to 35 % decrease in fuel use (D'Angelo et al. 2008). Prowell et al. (2012) have summarized the energy consumption from fifteen WMA projects, representing six technologies and report an average measured fuel consumption reduction of 23 %. Similarly, the NCHRP 9-47A draft final report (West et al. 2014) shows savings of 22.1 % for an average temperature reduction of 27 °C at five different production plants. The project results also indicate that the theoretical calculations underestimate the actual fuel savings at an average by 45 %. The additional reduction is attributed to casing losses—heat radiated through the

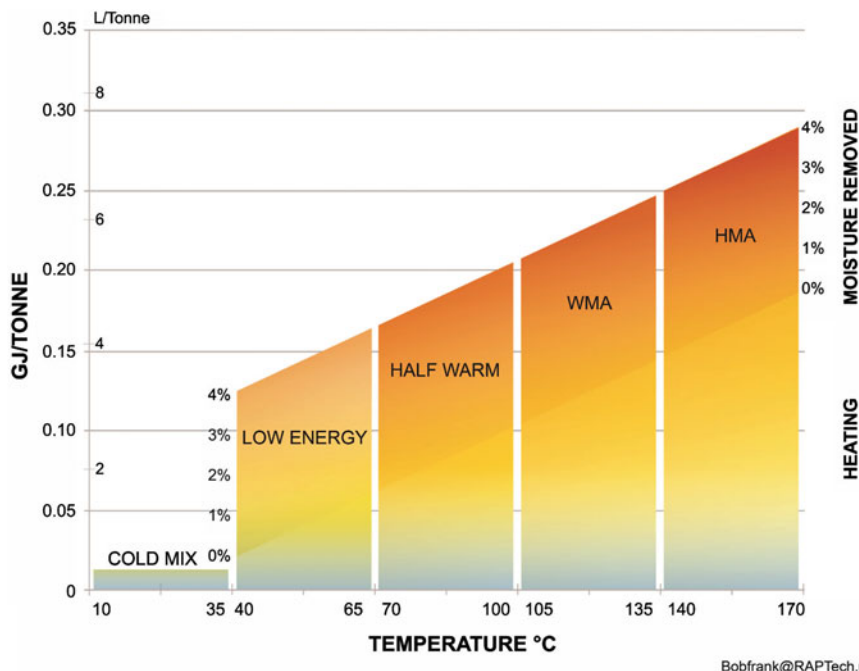

**Fig. 10.1** Asphalt production energy consumption (specific heat factors from (WALTOW 2011), kJ/kg-°C: limestone 0.909, granite 0.804, basalt 0.837, sand 0.8, bitumen 1.675, water 4.187, steam 2.01, air 1.005. Latent heat of vaporization for water 2257.2 kJ/kg.) (courtesy of B. Frank)

drum, ductwork, and baghouse or otherwise lost. Zaumanis et al. (2012a) have calculated energy consumption in the entire production cycle and 7 to 18 % reduction in energy use has been reported, with the conclusion that the savings are strongly linked with the production temperature. Practical field measurements have shown that if technologies that allow WMA production close to the boiling point of water are utilized (for example Low Emission Asphalt), the energy savings in production can be greater than 50 % (Prowell et al. 2008).

### 10.2.3.2 Reduction of Emissions

As expected from the reduction of fuel consumption, the vast majority of reports indicate reduction of CO<sub>2</sub> emissions due to use of WMA. This has often allowed for the use of WMA technologies in non-attainment areas (often large metropolitan areas) where HMA application is limited. The relationship between fuel and CO<sub>2</sub> reductions is shown to be linear (Frank et al. 2011). This concurs with the NCHRP report 9-47A draft that evaluated seven different technologies at three locations and reports an average 20 % reduction in CO<sub>2</sub> emissions resulting from a 21 % reduction in fuel use for a mean temperature reduction of 29 °C (West et al. 2014).



Data provided by UK Carbon Trust (2010) allows calculations which show that switching to WMA production would provide CO<sub>2</sub> savings of 9 %. D'Angelo et al. (2008) reports plant stack emission reduction of CO<sub>2</sub> in the range of 15 to 40 %, SO<sub>2</sub>—20 to 35 %; nitrous oxides (NOX)—60 to 70 %, volatile organic compounds (VOC) up to 50 %, and carbon monoxide (CO)—10 to 30 %. Frank et al. (2011), however, notes that the CO and VOC emissions are a part of broader plant practices and may not be directly related to the use of WMA.

The reduced temperature in some cases may require plant burner tuning. As reported in NCHRP 9-47A draft it can be difficult to properly adjust the burner to maintain the optimum fuel/air ratio over the whole firing range. Incomplete combustion will result in both increased fuel use and higher emissions (West et al. 2014). The unburned fuel may cause contamination of the produced asphalt and an increase in the VOC and/or CO emissions (Harder 2008; West et al. 2014).

The reduction of aerosols and fumes is also beneficial to paving crews as visible in Fig. 10.2. Keeping the emissions low is especially important in unfavorable settings like tunnels or underground garages. The results of a study by Kriech et al. (2011) showed average reduction in total organic matter (TOM) of 36 % compared to HMA. The authors also noted that different asphalt binders exhibit significantly different breathing zone exposure levels, thus the effects of lowering the temperature may vary from site to site. A report by D'Angelo et al. (2008) indicate reductions of aerosols/fumes and polycyclic aromatic hydrocarbons (PAHs) in the range of 30–50 %. McClean et al. (2012) reports reduced dermal absorption of polycyclic aromatic compounds (PACs) metabolites when reducing temperature from 154 to 121 °C. It has also been recognized that use of WMA is very beneficial for application of mastic asphalt, polymer or rubber modified mixtures. These types of pavements are placed at much higher temperatures compared to HMA and thus exhibit higher emissions. It has been demonstrated by Spickenheuer et al. (2011) that a 10 °C increase in application temperature results in a 20 % increase in concentrations of vapors and aerosols at the typical mastic asphalt application range of 216–270 °C.



**Fig. 10.2** Paving of WMA (left) using foaming technology and HMA (right)

### 10.2.3.3 Life Cycle Analysis

Due to the production specifics of WMA, it may promise several benefits that are indirectly related to the reduction of atmospheric pollution. Reduction of fuel used for asphalt production aids in reducing the demand of non-renewable fuel extraction and dropping the carbon footprint of fuel production and transportation. Lowering of bitumen viscosity in the production process allows the incorporation of a higher percentage of reclaimed asphalt pavement (RAP), thus further reducing the need of natural resources. The reduced aging of binder during the production and paving process may increase pavement durability, thus reducing the life cycle cost of WMA (research is ongoing in this area).

There are concerns that some of the environmental benefits may be offset due to the carbon footprint embodied in the production of additives and/or any additional equipment supporting the production of WMA. It must also be realized that the degree of emission reductions depends on the technology used for producing WMA and the type of fuel burned in the process. Additionally, because of the relatively short implementation period, there are still some concerns about the WMA long term performance compared to Hot Mix Asphalt (HMA). If the longevity of the pavement is shorter than that of HMA, the life cycle emissions and also economic costs for WMA will likely negate any benefits that are gained during production. For this reason agencies often require firm proof of the performance of each technology before allowing its use in construction projects.

Use of life cycle assessment tool to calculate environmental effects may be beneficial for showing the environmental effects from WMA use and for comparing different products. Many calculators have been developed for such evaluation. The user must decide what phases of the asphalt life to consider in the calculations. For example, NAPA provides a simple calculator (NAPA 2012) with a gate-to-gate analysis of the asphalt production phase. The user only needs to input the fuel consumption data of the plant and the equipment used. The calculator utilizes its existing database for reporting the emissions as CO<sub>2</sub> equivalent. It also rewards the use of RAP and RAS in mix design. Other calculators could also include the production of raw materials, construction, maintenance of pavement over a pre-defined period, use phase, and end of life solutions. However, care must be given to uncertainties in the calculations that can introduce bias into the conclusions (Capitao et al. 2012).

### 10.2.4 Costs

The use of WMA, can result in both reductions and increases in production expenses, depending on the circumstances. The calculations should be based on several important variables, which are summarized in this section.

### 10.2.4.1 Savings

Different techniques of producing Warm Mix Asphalt promise various energy savings for production. The economic benefit from energy savings should be addressed together with the cost and type of energy used, as higher energy prices promise greater savings. Most contractors report a burner fuel usage decrease of 10 to 15 % and savings ranging from \$0.10 to \$0.80 per ton depending on the fuel type and temperature decrease (West 2013). It is estimated that the production of 47 million tons of WMA in 2010, saved 30 million gallons of fuel worth more than \$80 million (Nadau 2012). In the UK, it is estimated that for a typical asphalt plant the WMA technology installation costs are low compared to other means of reducing emissions and the payback period is up to 1 year (Carbon trust 2010). Higher RAP use, which may be realized by the use of WMA, can also significantly reduce the material costs of asphalt mixtures.

Economic benefits should be evaluated together with environmental effects. If stricter emission standards are implemented, there may be higher economic incentive for WMA use. In this case the potential savings may not be immediately quantifiable and should be evaluated together with potential changes in environmental regulations.

Some indirect economic benefits can be ensured in paving process. The ability to work at colder ambient temperatures can extend the paving season thus providing contractors to additional profits. Due to the improved workability contractors are also more likely to reach the required density, thus avoiding the penalties for unsatisfactory compaction. These reduced compaction risks, if realized, can provide longer lasting pavements that can far exceed additional costs for WMA production.

### 10.2.4.2 Cost Increases

The savings from WMA production may be offset by the additional costs of WMA production. Each specific case must be evaluated to determine if reduced energy consumption will reduce the overall costs of WMA production. Different WMA technologies will require various additional costs depending on the process and existing plant. Increase in costs may arise from (Zaumanis and Smirnovs 2011):

- Investment and the depreciation of plant modification.
- Costs of the additives.
- Costs for technology licensing.

## 10.3 WMA Technologies

WMA technologies rely on temporary or permanent alteration of binder properties or modification of bitumen-aggregate interaction. The market currently consists of three different production techniques that can be found individually or in combination with each other:

- Foaming technologies, including mechanical foaming and water bearing minerals.
- Organic or wax technologies.
- Chemical additives.

Currently there is no industry standard definition of WMA production temperatures and therefore the classification primarily depends on the user. In practice many contractors produce WMA at temperatures that are very similar to HMA to aid in compaction.

Classification of the technologies by the degree of temperature reduction aids evaluation of the possible energy savings and economic benefits of WMA and allows comparing the temperature reduction potential of specific technologies. Often a temperature reduction of 30 °F (17 °C) has been recognized as the threshold for defining asphalt as a warm mix (FHWA 2012). However, this classification greatly depends on the type of binder used and the mixing temperature of the reference hot mix asphalt. A situation can arise when WMA has a higher production temperature than a different hot mix, for example when a modified binder is used in WMA. For this reason classification by the resulting mix temperature is mentioned in some sources (D'Angelo et al. 2008):

- Cold mix (up to 30 °C).
- Half warm asphalt (65–100 °C).
- Warm mix asphalt (100–140 °C).
- Hot mix asphalt (above 140 °C).

### ***10.3.1 Foaming Technologies***

Foaming technologies use small amounts of cold water introduced into the hot binder or directly in the asphalt mixing chamber. This can be accomplished by using foaming nozzles, by adding zeolite, or by introducing a portion of wet aggregates (Zaumanis 2010). The water rapidly evaporates and is encapsulated in the binder, producing large volume of foam which slowly collapses before the binder reverts to its original characteristics (Capitao et al. 2012). The foaming action in the binder temporally increases its volume and lowers its viscosity, which improves coating of aggregates and enhances mix workability. In the foaming processes enough water must be added to cause foaming action, without adding too much to cause stripping.

The properties of the foamed bitumen can be characterized by two parameters (Jenkins 2000):

- Expansion ratio—ratio of maximum volume of foamed bitumen to the original volume of bitumen.
- Half-life—time measured in seconds for the foamed bitumen to subside from its maximum volume to half of the maximum volume.

The optimum foaming water content is generally identified as the amount in percentage of the foamed asphalt content that would achieve the highest expansion ratio and longest half-life. A higher expansion ratio promises larger surface area to coat the aggregates and a longer half-life will provide lower viscosity for a longer period ensuring enough workability of the mixture (Ozturk and Kutay 2013).

Several different methods of introducing water into the mixture have been used. Mechanical foaming uses some type of nozzle (or series of nozzles) as illustrated in Fig. 10.3 to inject a small amount of cold water into the asphalt binder stream. Most water injection systems add 1–2 % water by weight of asphalt binder. The water creates steam which is encapsulated in the binder resulting in foaming and a large volume increase of the binder. This decreases the viscosity thus allowing it to coat the aggregates at lower temperatures (Perkins 2009). The nozzles are computer controlled to allow adjusting the foaming rate.

Another way of foaming the binder is by adding water bearing mineral in the mixture at the same time as the binder. This foams the binder and reduces the viscosity. Finely powdered synthetic zeolite that has been hydro-thermally crystallized (Fig. 10.4) is often used. It contains about 20 % water of crystallization which is released by increasing the temperature above 85 °C. When the additive is added to hot binder a fine mist provides 6 to 7 h of increased workability (Chowdhury and Button 2008; D'Angelo et al. 2008). Zeolites are typically added at 0.25–0.30 % by weight of mixture.

There are two widely used foaming technologies that require additional explanation since they use unique technological processes.

Low Emission Asphalt (LEA) uses sequential mixing technology as illustrated in Fig. 10.5. The coarse aggregate and a portion of fine aggregate are heated to normal HMA temperatures (approx. 150 °C) and mixed with the total amount of binder containing coating and adhesion additives. After the coarse aggregate is coated with the binder, it is mixed with the cold, wet fine aggregate, ideally containing 3–4 % moisture. It results in foaming action that aids in the coating of the fine aggregate (Perkins 2009; D'Angelo et al. 2008). The resulting mix temperature is less than 100 °C. In a drum plant, the fine aggregate can be added through the reclaimed

**Fig. 10.3** Double barrel green nozzle

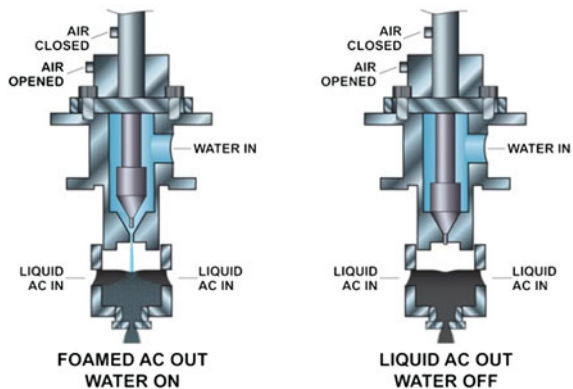

**Fig. 10.4** Advera zeolite

asphalt pavement (RAP) collar (D'Angelo et al. 2008). LEA-CO has also developed a LEA production kit that can be attached to a batch plant (Chowdhury and Button 2008).

WAM-Foam uses a two component binder system. The aggregate is heated to about 130 °C and then coated with a soft binder, which is typically 20 to 30 % of the total binder. A hard binder at about 180 °C is then foamed into the mixture by adding cold water (2–5 % of mass of the hard bitumen). Initial coating with the soft binder satisfies the asphalt binder absorption of the coarse aggregate that may not otherwise occur with the stiffer binder at a low temperature. At a drum plant the additional binder line is fitted along with the existing line but is not extended deep inside the drum, allowing the soft binder to first coat the aggregate. For a batch plant compressed air must be run through the water expansion chamber after each batch to prevent clogging (D'Angelo et al. 2008; Chowdhury and Button 2008).

### 10.3.1.1 Production Technology

**Foaming system** WMA technology producers offer their own production kit that can be fitted to contractors' plants. An example is illustrated in Fig. 10.6. The foaming nozzle must be installed in-line with the binder addition system. It must be supported by a water supply system (water pump, reservoir tank) and water metering system. A bitumen expansion chamber is required in most cases. The water addition processes can be controlled through a control unit from the plant operation center. Special attention should be given to maintain the ability to easily switch between the WMA and HMA production systems. The maintenance of the nozzles is another important issue as they may require special treatment and/or cleaning between the batches or after each production.

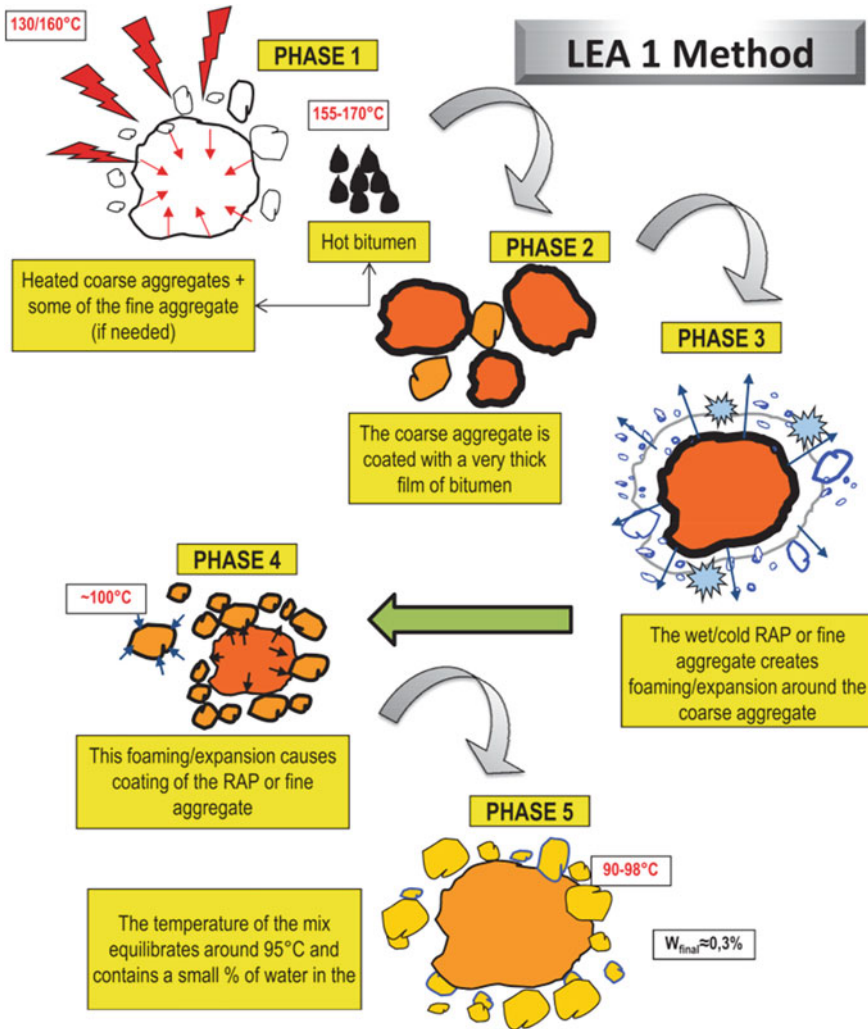
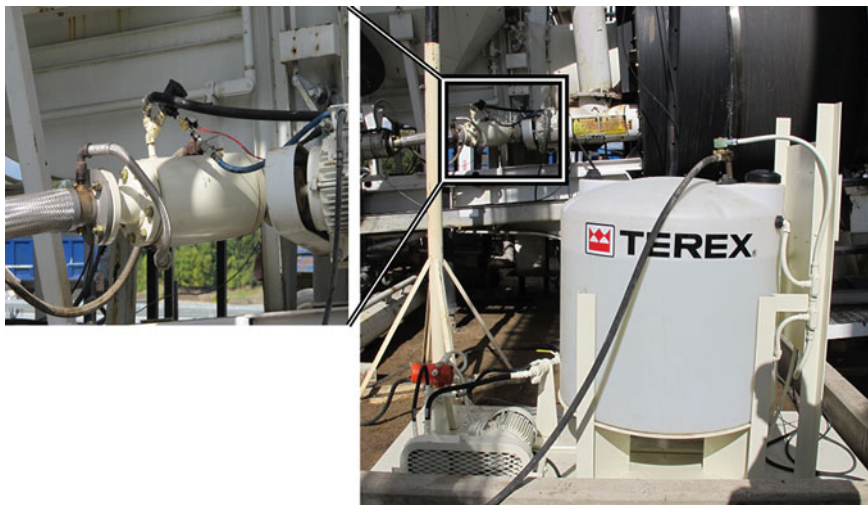

Fig. 10.5 Functional diagram of low energy asphalt (courtesy of LEA)

**Zeolite additives** in a batch plant can be added into the pugmill using a weight bucket or by blending in line with the binder. In a drum mix plant, they can be pneumatically fed into the drum via the RAP collar or using a specially built pneumatic feeder that introduces the additive in the binder line. The additive develops into a dispersed steam when it comes in contact with hot binder; therefore it must be introduced to the binder directly before addition of the aggregates.





**Fig. 10.6** Warm Mix Asphalt System water tank with water pump (*right*) and foam expansion chamber (*left*)

### 10.3.2 Organic Additives

Above their melting point organic (wax) additives reduce the viscosity and increase the lubricity of binder. In the mixing process this allows coating of the aggregates at lower temperatures, as illustrated in Fig. 10.7. After the pavement has cooled and the additives crystallize, they tend to increase the stiffness of the binder and asphalt's resistance against plastic deformation. The type of wax must be carefully selected to ensure that its melting point is higher than the expected in-service temperature and to minimize embrittlement of the asphalt mixture at low temperatures. A temperature reduction range of 10–30 °C can be expected compared to HMA (Zaumanis 2010).

Sasobit is one of the most widely used organic additives. It is a Fischer-Tropsch (FT) wax in the form of white powder or granulate (Fig. 10.8). It is a long-chain aliphatic hydrocarbon wax with a melting range between 85 and 115 °C, high viscosity at lower temperatures, and low viscosity at higher temperatures. According to Drüschner (2009), with the addition of 3 % Sasobit by binder mass, the binder softening point is decreased by 20–35 °C and the penetration falls by 15–25 1/10 mm. This accounts for the reported increased resistance to rutting of Sasobit-modified mixes (D'Angelo et al. 2008; Chowdhury and Button 2008). In the U.S. the most common introduction of additive is at 1.5 % by mass of binder. Some reports note slightly reduced low temperature cracking resistance when wax additives are used. Qin et al. (2014) report a 2.0 to 3.5 °C increase in the limiting low temperature grade when Sasobit was used at a 1.5 to 3.0 % dose. Other waxes have similar effects on binder as the described product.



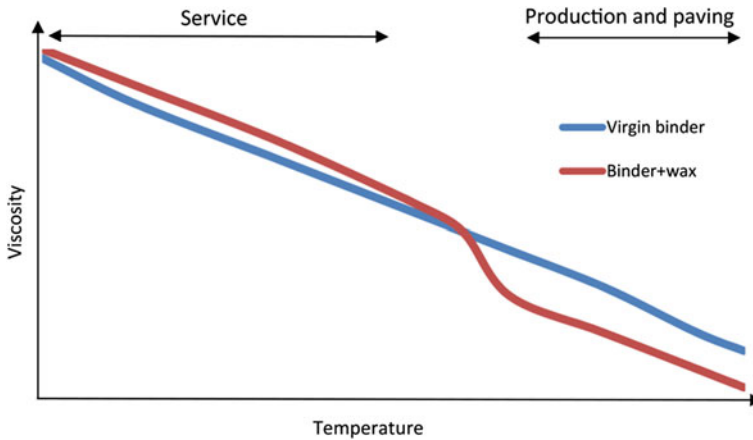

**Fig. 10.7** Viscosity change of wax-modified binder

**Fig. 10.8** Sasobit addition to binder in laboratory



### 10.3.2.1 Production Technology

Wax additives are usually delivered in granular form. They can be added to asphalt mixtures in several different ways. The most effective method for ensuring homogeneous mixing is pre-blending with bitumen at a refinery, a terminal, or an asphalt plant. It must be ensured that the wax is stable and stays homogeneous in the binder storage tank. In another method, the wax additives can be heated in a separate tank and injected in a liquid state in-line with the binder addition. The granular form of the additives also allows direct addition of the additive into the asphalt mix using a pneumatic feeder, a weight hopper or an existing fiber addition system. In this case it must be ensured that the additive is homogeneously distributed and well blended

with binder. To guarantee this it may be necessary to extend mixing time (especially in batch plants).

### ***10.3.3 Chemical Additives***

Chemical additives are the third type of WMA technology that is commonly used. A variety of chemical packages are used for different products. They usually include a combination of emulsification agents, surface active agents, polymers and additives to improve coating, mixture workability, and compaction. These products generally improve the adhesion of binder and aggregates thus eliminating the need for additional adhesion additive. Most additives are designed to not change the grade of the binder. Chemical additives may reduce the asphalt mixing and production temperature by up to 30 °C (EAPA 2010; Capitao et al. 2012).

#### **10.3.3.1 Production Technology**

Chemical additives are most often provided in a liquid state and are readily soluble in asphalt binder. This results in relatively minor modifications to the asphalt plant. Additives can frequently be easily added to the binder using existing plant equipment, such as the liquid anti-strip additive in-line injection system. If no such equipment is available, a volumetric pump with a precise metering system can be installed. In some cases the additive may require heating to ensure flow. Liquid additives are mostly stable in the binder and can therefore be added at the binder terminal, or the storage tank at the asphalt plant. A stirring unit for bitumen is necessary if additive is introduced into the bitumen tank. The additive may also be pre-blended by the producer and delivered in the form of bitumen emulsion. Some products are delivered in granular form (Fig. 10.9) and can be added similarly to waxes.

### ***10.3.4 Choosing a WMA Product***

In 2013 there are more than 30 products to choose from in the market and the list is constantly increasing. The advantages of using a particular WMA production method can be different from product to product. Therefore, a careful evaluation of the benefits for choosing one method over another for a particular situation is necessary. The critical aspects to consider for choosing WMA technology for the use in specific project are:

- Warm Mix Asphalt performance.
- Cost of the WMA additives and/or equipment.

**Fig. 10.9** Rediset WMX granules



- Production and compaction temperature.
- Planned production rates.
- Existing plant equipment.
- Environmental regulations.
- Local performance test requirements.

### ***10.3.5 WMA Technology Acceptance***

Due to the rising popularity of WMA, the number of new products is constantly increasing. This requires a standard methodology for the approval of new technologies. The use of WMA should be allowed only if it can provide the same or better mechanical characteristics and long-term performance as HMA. This requirement cannot usually be met by performing laboratory tests alone; therefore field trial with performance monitoring is included. Such requirements have been developed by several agencies and a list of approved technologies is published in some regions. However, the fact that most states require different approaches makes approval of new products costly. A national standard with clear requirements for certification would be very beneficial for increasing competition, and thereby reducing costs of WMA technologies.

The European WMA scanning report (D'Angelo et al. 2008) indicates that in Germany there is an evaluation system to assess and approve new products. This process combines laboratory performance tests and field trials with consecutive monitoring of performance. The trials must meet the following conditions: high traffic volume, right hand (slow) lane, and section lengths of more than 500 m.

During the specified 5 year evaluation period, the sections are monitored for transverse profile, layer thickness, and surface condition. The test sections are constructed in conjunction with a control section.

## **10.4 WMA Mix Design Considerations**

Warm Mix Asphalt has been used in all types of asphalt materials, including dense graded, stone mastic, porous, and mastic asphalt. It has been used with different aggregates, various grades of binder, polymer modified and rubberized bitumens, as well as for producing mixtures containing RAP and RAS. A variety of layer thicknesses and traffic levels have been applied to WMA. Based on these findings, there are generally no restrictions on WMA implementation. There are, however, some considerations regarding WMA design procedures that may be different from HMA and should be taken into account to ensure performance equal to that of Hot Mix Asphalt (HMA).

### ***10.4.1 Binder Content***

Mixture designed as WMA, may exhibit less binder absorption due to lower temperatures. Together with increased workability this may result in a lower amount of air voids and, according to mix design practices, require a reduction in binder content. However, there is consensus in the industry that this would result in a stiffer mix that is susceptible to cracking, raveling (Jones et al. 2012), accelerated oxidative aging, and moisture susceptibility. Therefore, the current practice is to use an approved HMA mix design binder content and substitute the WMA process without changes in the binder content. For these reasons the WMA is often designed using the “drop in” method. That is, the mixture is designed according to HMA standard mix design practices and WMA technology is introduced without changes in other mix design parameters.

### ***10.4.2 Binder Grade***

As described above, bitumen exhibits less aging in the WMA production process. If the difference in production temperature is very large it may be necessary to bump the high temperature PG in order to compensate for the less aged WMA binder and avoid plastic deformations of the pavement soon after opening to traffic.

NCHRP report No.691 (Bonaquist 2011a) recommends considering an increased high performance grade if the difference in PG between the binder extracted from HMA and WMA exceeds 3 °C. Since various binders exhibit different susceptibilities

to aging, a fixed reduction in temperature for which the binder grade should be increased cannot be determined. For a typical binder with average aging susceptibility, a temperature difference between HMA and WMA production temperatures of more than 30 °C would require a change in the high binder grade. The same report suggests that the low temperature grade should not be altered, since changes between HMA and WMA in resultant low PG temperature are relatively small.

### 10.4.3 Mixing in Laboratory

Laboratory mixing of WMA with organic and chemical technologies does not require modifications, other than the addition of the right amount of additives. There are two methods of introducing additives into the mixture:

- Addition to binder before mixing with aggregates simulates pre-blended binder.
- Adding additives together with binder simulates the in-line addition process.

Production of WMA with foaming technologies in the laboratory is rather challenging and three production technologies can be distinguished:

- Foaming additives can be introduced to aggregates together with binder and will offer a limited time of improved workability. Precaution must be used because of the water steam in the process.
- Water injection with nozzles is technology dependent and will vary by type of nozzle, addition rate, water pressure, etc. There are several commercially available foamers for simulation of this process (Fig. 10.10) albeit precise replication of the full-scale operation is challenging.
- Sequential addition of materials to simulate processes of WAM-Foam and LEA may be impossible in the laboratory because of an inability to simulate the strict full-scale technological operations in the laboratory.

**Fig. 10.10** Wirtgen WLB 10 S (*left*) and Pavement Technology's The Foamer (*right*) laboratory foaming units



### 10.4.4 Production and Compaction Temperature

For normal paving grade binders the production technology can be determined based on the required binder viscosity. WMA technologies use various methods to increase the binder workability, improve “wettability” of aggregates and “lubricity” of binders. Therefore evaluation of the binder alone will not enable determination of the optimum compaction temperature. Moreover, WMA processes are often hard to replicate in the laboratory which means the optimum mixing and compaction temperature should preferably be determined in field conditions.

One method for determining the optimum temperature in laboratory is by comparing the bulk density of reference HMA with that of WMA at different temperatures but equal compaction forces. The temperature at which both densities are the same can be determined. This can be defined as the optimum compaction temperature. This is illustrated in Fig. 10.11. However, the Superpave gyratory compactor has been recognized as relatively insensitive to temperature changes and therefore may not be suitable for this purpose (Hurley and Prowell 2006).

If RAP or RAS is used in the mix design the minimum production temperature must also be adjusted to facilitate melting of the hard binder. To ensure sufficient mixing of virgin and aged binders NCHRP project 9-43 (Bonaquist 2011a) suggests to limit the minimum WMA paving temperature above the high temperature Performance Grade (PG) of RAP or RAS. The same project showed that PG of RAP recovered binder typically does not exceed 94 °C, meaning that most warm mix technologies allow incorporation of RAP at the producer specified WMA temperature. However, the recovered high PG temperature for tear off shingles can exceed 130 °C, thus potentially limiting the reduction of temperature.

### 10.4.5 RAP and RAS Content

Due to the binder viscosity reduction in WMA, stiff mixes, such as those containing a high percentage of Reclaimed Asphalt Pavements (RAP), can be made easier to work with. The reduced viscosity is beneficial to the workability of the mixture and

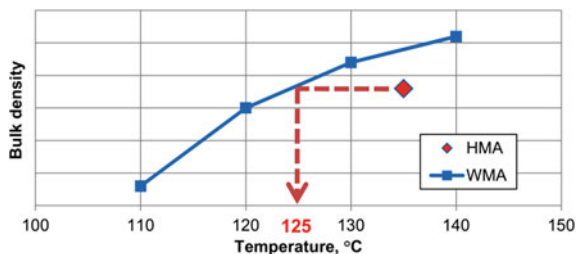

Fig. 10.11 Example of determination of compaction temperature from bulk density

the decreased aging of the binder compensates for the stiffer RAP binder, reducing the cracking potential. According to the NCHRP research project No. 691 (Bonaquist 2011a) the RAP amount in an asphalt mixture can be increased by 10 % if, due to the reduced oxidation, the low performance grade is 0.6 °C lower than that of conventional asphalt. For a typical asphalt binder this can be achieved through a reduction of the production temperature by 28 °C.

It was reported by NAPA research (Gandhi 2008) that for mixes containing high percentages of RAP, the compaction effort was reduced by 40 % when using Sasobit. In Germany, a study (D'Angelo et al. 2008) was presented in which 45 % RAP was used in the base course containing Aspha-min WMA. In the Netherlands LEAB Warm Mix Asphalt is routinely produced with 50 % unfractionated RAP (D'Angelo et al. 2008). A study in Maryland (Kristjansdottir 2007) concluded that the use of Sasobit allowed an increase in the amount of RAP from 25 % for HMA to 45 % for WMA. A course of 5 km was placed and it was estimated that the financial benefits of a higher RAP content can compensate for the additional costs of the WMA technology.

#### **10.4.6 Laboratory Aging**

It is recognized that while the physical properties of binders may initially be the same, their properties change when exposed to heat and other external factors. Short term aging occurs during mixing with aggregates, transportation and the laying processes. If the WMA mixtures are produced at significantly lower temperatures the aging may be reduced. Moreover, there are evidences (Lee 2008) showing that short term laboratory aging is more critical for WMA as compared to HMA and can influence the testing results to a large extent.

The NCHRP report 691 (Bonaquist 2011a) suggests using 2 h aging (instead of the four used for HMA) at planned field compaction temperature before running performance tests, which is supported by other research (Hurley and Prowell 2006). These conditions are believed to more closely simulate actual aging during production than the conventional HMA aging of 4 h at 135 °C according to AASHTO R30.

For the products that involve foaming actions to reduce bitumen viscosity and allow better workability of the mix, additional aging time may be necessary to allow dissipation of the added moisture before performing the tests.

### **10.5 Performance**

The performance of WMA, like that of HMA, can vary based on specific application circumstances, such as mix type, WMA technology, and production temperature. This section broadly presents general tendencies of WMA performance as compared to a similar HMA.

### ***10.5.1 Density***

Because of lower initial temperature warm mixes cool at a slower rate than HMA which provides a longer compaction window. The pavement in most cases also requires a smaller compaction effort even at a reduced temperature. However, the periods of mix tenderness are also generally longer and may require holding back the breakdown roller (Jones et al. 2012). For example, in Germany 3 % Sasobit was used for WMA and after only one roller pass at a 125 °C a compaction of 96 % was obtained (D'Angelo et al. 2008). The benefit of better workability has also been used for stiff HMA to overcome problems with reaching the desired compaction degree. In Massachusetts Sasobit was used as a compaction aid (Mogawer and Austerman 2008). The target density of 96 % could not be achieved with contractors' equipment. Addition of 1.56 % of Sasobit not only allowed to lower the temperature by 10 °C, but the target density was also achieved using less compaction effort compared to HMA. The rolling, however, must be finished before the wax starts to crystallize to avoid damaging the asphalt binder structure.

In the quality control of eleven WMA field trial sections (Brown 2011a, b) NCAT has not observed major differences in HMA and WMA compactability and the required density was generally achieved with both hot and warm mix asphalt. In Virginia (Diefenderfer and Hearon 2010) field trials with Sasobit and Evotherm included assessment of compaction during a period of 2 years to determine whether further compaction after placement is a problem for WMA. The results show that although the air void content varied, no correlation between time and void content was established and no significant differences between any of WMA sections and control sections of HMA were observed. Similar results are reported by NCAT who has monitored multiple construction sites for periods of 1 to 2 years but has not observed differences between HMA and WMA in-site densification (NCAT 2013).

There have been cases when the WMA technologies have shown lower compaction (Kvasnak et al. 2010; Jones et al. 2008). This is probably connected with the reduction of compaction temperature below workability limits. The air void content for field cores in these two projects was 1.3–6.0 % higher than for the control HMA test section and did not reach the required density.

### ***10.5.2 Moisture Susceptibility***

Moisture susceptibility may be an important issue for WMA technologies and in many cases it has been reported different for WMA and HMA even if the same constituent materials are used. There are two reasons for this. If the moisture contained in the aggregates does not completely evaporate during mixing due to low mix temperatures, water may be retained in the aggregate which could in turn lead to increased susceptibility to moisture damage (Jones et al. 2012). This is even more critical for foaming WMA technologies, because of possible residual moisture left behind by the microscopic foaming process. Most research studies report



reduced moisture resistance when a foaming process is used (Hurley and Prowell 2006; Jones et al. 2011) and for this reason most foaming technology suppliers advise the use of antistripping additives to improve adhesion. Hydrated lime as well as amines have proven to be effective in increasing the adhesion for WMA mixtures but care should be given to product choice since the lower temperatures used for WMA production may reduce the effectiveness of some antistripping additives (Perkins 2009). NCHRP project 9-43 (Bonaquist 2011a) reports that for WMA mixtures that did not use an antistrip additive the tensile strength ratio (TSR) (according to AASHTO T 283) decreased in 79% of the mixes compared to the control HMA. When adhesion promoter was used, the TSR increased in 67 % of the cases and was never lower than that of HMA. Many WMA chemical technologies already use antistripping additives and therefore eliminate the need for introduction of an additional adhesion agent.

Based on the considerations above, moisture sensitivity testing should always be a part of WMA mix design. The draft for WMA mixture design in AASHTO R 35 standard suggests testing of WMA moisture susceptibility with no modification compared to the HMA test methodology. If the minimum requirement of 0.8 TSR dry to saturated ratio cannot be met, antistrip additives should be used. The Hamburg wheel tracking test in water and the stripping inflection point is another proven method for the evaluation of stripping resistance and the test method is reported to be sensitive to factors that are important for WMA, including binder stiffness, length of short-term aging, compaction temperature, and anti-stripping treatments (Aschenbrener 1995).

### ***10.5.3 Cracking***

Because of its reduced production temperature, WMA binder has often not aged as much as HMA and therefore may have improved fatigue and low temperature cracking performance. This may be especially beneficial for mixtures containing RAP and RAS. The less aged WMA binder compensates for the hard RAP or RAS binder, thus reducing susceptibility to cracking.

Due to reduced aging, the low temperature PG may be somewhat lower for WMA compared to HMA extracted binder. Bonaquist (2011b) reports low temperature grade reduction between 0.5 to 3 °C, depending on the technology and production temperature, which promises increased resistance to low temperature cracking of asphalt pavement. However, while Bonaquist's study did not show such an effect, some other studies have reported that the addition of wax might increase the low temperature grade by 2–3 °C (Wanger et al. 2008; Chowdhury and Button 2008) and Fraas temperature by 1–5 °C (Zaumanis et al. 2012b).

NCAT summary of WMA performance in field studies (Brown 2011b) show that in terms of cracking, WMA technologies have performed similarly to HMA between 1 and 5.5 years of age. In most of the eleven evaluated projects there was only small amount of cracking observed in both HMA and WMA. In a St. Louis

project a severe reflective cracking was observed for both HMA and WMA. In two projects with Sasobit, slightly more cracking was recorded compared to HMA after 3.5 and 4.8 year of service.

### **10.5.4 Rutting**

Since WMA binder exhibits less aging, the resultant binder is less stiff and thus potentially more prone to rutting early in service life. The exception from this trend is the technologies that use waxes because wax stiffens the mixture at in-service temperatures thus ensuring high rutting resistance. For other technologies reduced rutting resistance has been shown in numerous laboratory studies (Hurley and Prowell 2006; Lee 2008). However, while the laboratory performance in many cases shows an increase in plastic deformations, the actual field rutting resistance has been reported as very similar to hot mix asphalt and generally no rutting problems have been observed. For example, the maximum rutting that was observed by NCAT from thirteen field trials with various climatic conditions and service periods of up to 5.5 years was 6 mm which was equal to the hot mix asphalt control sections (Brown 2011b). The effect of reduced aging on increased pavement rutting is likely limited to applications of thicker WMA pavements (e.g. 120 mm) in hot climates for the first months in heavy traffic (Jones et al. 2012).

Based on the fact that the laboratory performance test results often do not reflect the actual field observations, several US state agencies have reduced their requirements for laboratory rutting resistance when WMA technologies are used. For example, in order to better reflect the warm mix aging, NCHRP report 691 (Bonaquist 2011a) recommends conditioning at WMA compaction temperature and the aging time is reduced to 2 h compared to 4 h for hot mix asphalt. These changes lead to reduced rutting resistance. Therefore, the minimum flow number requirement (rutting resistance criteria) has been reduced to reflect field performance. If the requirements cannot be passed, bumping of binder grade can be considered as disused earlier in Sect. 10.4.2.

## **10.6 Conclusion**

There is a number of benefits from using WMA technologies, including the ability to enhance compaction, reduce the amount of greenhouse gas emissions from production, reduce energy consumption, increase the RAP content, open traffic earlier, pave in cold weather and consecutively increase paving season. These benefits along with competitive costs have caused rapid increase in the use of WMA and most states in the US have adopted specifications allowing WMA use in construction of public roads.

Monitoring of the pavement performance of WMA construction projects has shown that with adequate mix design, production and paving technology, the pavement performance is equal to that of conventional hot mix asphalt. The major considerations for ensuring WMA performance include the necessity of adding adhesion additives to enhance moisture resistance when using foaming technology WMA and accounting for reduced aging in order to avoid the formation of plastic deformations. The “drop in” method for the design of WMA mixtures has proven to be a good choice for ensuring pavement performance. That is, design the mixture as HMA and introduce the WMA process in the production plant.

The upcoming challenges for ensuring WMA quality and encouraging further spread of the technology include developing of a WMA standard design procedure in the laboratory, establishing methodology for determination of the optimum temperature for a particular technology, development of test methods or criteria that reflect WMA in-service performance, and the use of a life-cycle assessment methodology to highlight the environmental benefits of WMA. The procedure for approving new WMA technologies needs to be unified in order to further encourage design of new and better technologies and to increase competition.

**Acknowledgments** The help by Erik Olesen, Erik Nielsen, and Robert Frank, in providing insights of WMA, and Rudy Pinkham for technical assistance is greatly appreciated.

## References

- Aschenbrener, T. (1995). Evaluation of Hamburg wheel-tracking device to predict moisture damage in hot mix asphalt. *Transport Research Record*, 1492, 36–45. (Washington D.C.).
- Bonaquist, R. (2011a). Mix design practices for warm mix asphalt. NCHRP Report 691, Washington, D.C.
- Bonaquist, R. (2011b) Mix design practices for warm mix asphalt. In: *Second International Warm Mix Conference, NCHRP 9-43, St. Louis, MO*.
- Brown, R. (2011a). Status of implementation. [http://www.warmmixasphalt.com/submissions/149\\_20121112\\_6%20Status%20of%20Implementation-Workshop.pdf](http://www.warmmixasphalt.com/submissions/149_20121112_6%20Status%20of%20Implementation-Workshop.pdf). Cited 23 Mar 2013.
- Brown, R. (2011b). Performance of warm mix asphalt. [http://www.warmmixasphalt.com/submissions/148\\_20121112\\_5%20Performance%20of%20WMA,%20Atlanta%20WMA%20Workshop.pdf](http://www.warmmixasphalt.com/submissions/148_20121112_5%20Performance%20of%20WMA,%20Atlanta%20WMA%20Workshop.pdf). Cited 3 Mar 2013.
- Capitao, S. D., Picado-Santos, L. G., Matinho, F. (2012). Pavement engineering materials: Review on the use of warm-mix asphalt. *Construction and Building Materials*, 36, 1016–1024. <http://dx.doi.org/10.1016/j.conbuildmat.2012.06.038>.
- Carbon trust. (2010). Guide to the asphalt sector. In: *Industrial energy efficiency accelerator*. London, UK.
- Chowdhury, A., & Button, J. (2008). *A review of warm mix asphalt*. Springfield, VA: Texas Transportation Institute.
- D’Angelo, J., Harm, E., Bartoszek, J., et al. (2008). Warm-mix asphalt: European practice, FHWA-PL-08-007, Washington, DC.
- Diefenderfer, S. D., Hearon, A. J. (2010). Performance of Virginia’s warm-mix asphalt trial sections, FHWA/VTRC 10-R17, Charlottesville, VA.
- Drüschner, L. (2009). Experience with warm mix asphalt in Germany. NVF-rapporter, Sønderborg, Denmark.

- EAPA. (2013). *Asphalt in figures*. Brussels: European Asphalt Pavement Association. <http://www.eapa.org/userfiles/2/Asphalt%20in%20Figures/Asphalt%20in%20figures%2022-11-2013.pdf>.
- EAPA. (2010). *The use of warm mix asphalt*. Brussels: European Asphalt Pavement Association—position paper.
- FHWA. (2012). *Warm mix asphalt FAQs*. <http://www.fhwa.dot.gov/everydaycounts/technology/asphalt/faqs.cfm#tab2> Cited 3 Oct 2013.
- Frank, B., Prowell, B. D., Hurley, G. C., West, R. C. (2011). Warm mix asphalt (WMA) emission reductions and energy savings. In: *2nd International Warm-Mix Conference, St.Louis, MO*.
- Gandhi, T. (2008). Effects of warm asphalt additives on asphalt binder and mixture properties. *Doctor dissertation thesis*. Clemson University, Clemson, SC.
- Hansen, K. R., Copeland, A. (2013). *Annual asphalt pavement industry survey on recycled materials and warm-mix asphalt usage: 2009–2012*. National Center for Asphalt Technology. Information series 138. Lanham, MD.
- Harder, G. A. (2008). *LEA half-warm mix paving report, 2007 Projects for NYSDOT*. Cortland, NY: McConaughay Technologies.
- Hurley, G., & Prowell, B. (2006). Evaluation of potential processes for use in warm mix asphalt (With Discussion). *Journal of Association of Asphalt Paving Technologists*, 75, 41–90.
- Jenkins, K. J. (2000). Mix design consideration for cold and half-warm bituminous mixes with emphasis on foamed bitumen. *Doctoral Dissertation*. University of Stellenbosch, South Africa.
- Jones, C., West, R., Julian, G., et al. (2011). Evaluation of warm mix asphalt in Walla Walla, Washington. NCAT Report 11-06, Auburn, AL.
- Jones, D., Wu, R. Z., Tsai, B., Barros, C., Peterson, J. (2012). Accelerated loading, laboratory, and field testing studies to fast-track the implementation of warm mix asphalt in California. In: D. Jones (Ed.), *Advances in pavement design through full-scale accelerated pavement testing*. London: Taylor & Francis Group.
- Jones, D., Wu, R., Tsai, B. W., et al. (2008) Warm-mix asphalt study: Test Track Construction and First-Level Analysis of Phase 1 HVS and Laboratory Testing. UCPRC-RR-2008-11, Berkley, CA.
- Kriech, A., Osborn, L., Prowell, B., et al. (2011). Comparison of worker breathing zone exposures between hot mix asphalt and warm mix asphalt applications. In: *2nd Warm Mix Conference, St. Louis, MO*.
- Kristjansdottir, O. (2007). Warm mix asphalt technology adoption. NVF 33 Annual Meeting, Trondheim, Norway.
- Kvasnak, A., Moore, J., Taylor, A. et al. (2010). Preliminary evaluation of warm mix asphalt field demonstration: Franklin, Tennessee. NCAT Report 10-01, Auburn, AL.
- Lee, R. (2008). A Summary of Texas' experience with warm mix asphalt. In: *Presentation at Louisiana Warm-Mix Demonstration*. Shreveport, LA.
- Mogawer, W. S., Austerman, A. J. (2008). Laboratory and field evaluation of warm mix asphalt technology. In: *International Symposium on Asphalt Pavements and Environment*, (pp. 173–184). Zurich, Switzerland.
- McClellan, M. D., Osborn, L. V., Snawder, J. E., et al. (2012). Using urinary biomarkers of polycyclic aromatic compound exposure to guide exposure-reduction strategies among asphalt paving workers. *Annual Occupational Hygiene*, 56(9), 1013–1024. doi:10.1093/annhyg/mes058.
- Nadau, G. (2012). Warm mix takes off. *Asphalt Pavement Magazine*, 17(1), 16–21.
- NAPA. (2012) Greenhouse Gas Calculator. <http://www.asphaltpavement.org/ghgc/ghgcv4.html> Cited 19 Mar 2013.
- NAPA. (2014) How to determine mix cooling time. [http://www.asphaltpavement.org/index.php?option=com\\_content&view=article&id=178&Itemid=331](http://www.asphaltpavement.org/index.php?option=com_content&view=article&id=178&Itemid=331). Cited 19 Mar 2013.
- NCAT. (2013). NCHRP 9-47A Offers Recommendations for WMA Mix Design Changes. *Asphalt Technology E-News*, 25, 1. <http://www.ncat.us/info-pubs/newsletters/spring-2013/recommendations-for-wma-mix-design-changes.html>. Cited 22 Sep 2013.
- Ozturk, H. I., & Kutay, M. E. (2013). A Novel testing procedure for assessment of quality of foamed warm mix asphalt binders. *Journal of Materials in Civil Engineering*,. doi:10.1061/(ASCE)MT.1943-5533.0000924.

- Perkins, S. (2009). Synthesis of warm mix asphalt paving strategies for use in Montana highway construction. FHWA/MT-09-009/8117-38, Bozeman, MT.
- Prowell, B., Kvasnak, A., Hurley, G., et al. (2008). Engineering properties, emissions, and field performance of warm mix asphalt technologies. NCHRP 9-47, Lexington, KY.
- Prowell, B., Hurley, G., Frank, B. (2012). *Warm-mix asphalt: Best practices* (3<sup>rd</sup> ed.). Lunham, MD.
- Quin, Q., Farrar, M. J., Pauli, A. T., & Adams, J. J. (2014). Morphology, thermal analysis and rheology of Sasobit modified warm mix asphalt binders. *Fuel*, 115, 416–425.
- Spickenheuer, A., Ruhl, R., Hober, D., et al. (2011). Levels and determinants of exposure to vapours and aerosols of bitumen. *Archives of Toxicology*, 85(Suppl. 1), S21–S28.
- Vaitkus, A., Čygas, D., Laurinavičius, A., & Perveneckas, Z. (2009). Analysis and Evaluation of Possibilities for the Use of Warm Mix Asphalt in Lithuania. *Baltic Journal of Road Bridge Engineering*, 4(2), 80–86. doi:10.3846/1822-427X.2009.4.80-86.
- WALTOW. (2011). *Application Guide. Physical properties of solids, liquids and gases*. Chicago, IL.
- Wanger, M., Stangl, K., Blab, R. (2008). Fischer-tropsch paraffin modified bitumen—performance parameter and reduction of energy consumption. In: *ISAP International Symposium on Asphalt Pavements and Environment 197-206*. Zurich, Switzerland.
- West, et al. (2014). Properties and performance of warm mix asphalt technologies: Draft. National Center for Asphalt Technology-Auburn University. NCHRP Project 9-47A.
- West, R. (2013). Overview and discussion of warm mix asphalt technologies. In: *Advanced Mix Design course, NCAT*. Auburn, AL.
- Young, T. J., (2007). Energy conservation in hot-mix asphalt production. Quality Improvement Series 126, NAPA.
- Zaumanis, M., Jansen, J., Haritonovs, V., et al. (2012a). Development of calculation tool for assessing the energy demand of warm mix asphalt. *Procedia - Social and Behavioral Sciences*, 48, 163–172. doi:10.1016/j.sbspro.2012.06.997.
- Zaumanis, M., Olesen, E., Haritonovs, V., et al. (2012b). Laboratory evaluation of organic and chemical warm mix asphalt technologies for SMA asphalt. *Baltic Journal of Road Bridge Engineering*, 7(3), 191–197. doi:10.3846/bjrbe.2012.26.
- Zaumanis, M., Smirnovs, J. (2011). Analysis of possibilities for use of warm mix asphalt in Latvia. In: *Proceedings of Civil Engineering. International Scientific Conference*, (pp. 57–64). Jelgava, Latvia.
- Zaumanis, M. (2010). Warm mix asphalt investigation. *Master of Science thesis*. Kgs. Lyngby. Technical University of Denmark in cooperation with the Danish Road Institute.
- Zaumanis M., Mallick R.B. (2013). Review of very high-content reclaimed asphalt use in plant-produced pavement: state of the art. *International Journal of Pavement Engineering*. doi:10.1080/10298436.2014.893331

# Chapter 11

## Sustainability Issues Surrounding Unpaved Roads

Phil Paige-Green

**Abstract** The majority of the road networks in developing countries and large percentages in most developed countries are currently unpaved. This results in the road surface being directly exposed to traffic and the environment with a consequent continual loss of gravel, which needs to be replaced at regular intervals. This has severe environmental and sustainability implications and is totally unacceptable in these respects in the long term. Alternatives to this need to be developed such that the materials are either protected against environmental loss or are treated to an extent that the annual loss is significantly reduced. The optimum solution is to pave all roads with either a bituminous or concrete surfacing such that the material imported into the road is preserved against loss by erosion and abrasion. This is, however, probably not financially viable in most developing countries. The alternative is to treat the materials in some way that will reduce the annual loss. Research has indicated that, firstly by selecting the most appropriate materials and secondly, by improving construction methods, significant reductions in material loss are possible. To supplement this, methods of chemical or physical treatment can be considered to minimize material loss. Essentially, the status quo is no longer sustainable and a paradigm shift in this respect is urgently necessary. The impact of the use of water during the construction and maintenance of unpaved roads should also not be neglected.

### 11.1 Introduction

An analysis of international statistics related to road networks indicates vast differences in estimates of the length of roads in the world. However, it is clear that the majority of the world's roads are unpaved (weighted average of 51 % ([www.nationmaster.com](http://www.nationmaster.com) (2013)) out of a total length of about 102.3 million kilometres

---

P. Paige-Green (✉)

Tshwane University of Technology, Pretoria, South Africa  
e-mail: paigegreenconsult@gmail.com

© Springer-Verlag Berlin Heidelberg 2014

K. Gopalakrishnan et al. (eds.), *Climate Change, Energy, Sustainability and Pavements*,  
Green Energy and Technology, DOI 10.1007/978-3-662-44719-2\_11

335

([www.cia.gov](http://www.cia.gov) 2013). These estimates range over the years between 2000 and 2010 but are probably highly conservative (known figures from South Africa alone are underestimated by about 50 %). However, it can be safely assumed that the unpaved roads are typically constructed using in situ materials or materials imported from nearby local sources. Many of the unpaved roads consist of in situ materials or earth roads, which will at some stage require the application of a gravel layer in order to avoid the formation of canal-like structures, which do not guarantee all-weather passability.

Unpaved roads are generally constructed from virgin materials over which traffic passes. These roads are therefore subject to abrasion directly by traffic (high friction forces between the rotating wheels and the road) resulting in a gradual loss of material from the road surface. The quantity of gravel lost annually by traffic wear is a function of various factors as described later, as well as significant losses due to environmental factors. The loss on typical unpaved roads is about 20–25 mm per year. If this factor is applied to the total unpaved road network in the world (25 % of 102 million km assuming an average of 6 m wide), a minimum of about 3.34 million m<sup>3</sup> of gravel are lost per annum internationally. Based on the conservative road length figures discussed earlier, the actual figure is probably significantly more than this.

This material mostly ends up as dust in the atmosphere, eroded material in drainage courses or unusable gravel alongside the roads with mostly unknown consequences. In order to manage and maintain an unpaved road network in a balanced state, the average quantity of material lost each year should be replaced each year. Replacement of less than that lost annually means that the road network quality is deteriorating and more than this means that the network is being over-supplied with gravel. However, most road authorities have not been replacing material at the required rate and any overall positive addition of material would mostly be used to catch up with past replacement inefficiencies.

This estimated 3.34 million plus m<sup>3</sup> of gravel that needs to be replaced annually is usually obtained from local sources adjacent to the roads (typically within a maximum haul distance of about 5 km). The material is most cost-effectively obtained within the upper 1–5 m in borrow pits (after removal of top-soil and unsuitable overburden) and the actual layer worked is seldom more than about 2–3 m thick. Obtaining the necessary quantity of gravel thus requires the disturbance of more than 1.1 million m<sup>2</sup> (or about 1,000 square km) of property (often including indigenous vegetation in developing areas) per annum as well as significant transport requirements with their own environmental implications. These are definitely not sustainable scenarios and techniques to reduce the area of permanently disturbed land and the associated transport implications need to be urgently implemented.

The loss of gravel is not the only sustainability problem, especially in arid areas. In order to construct an unpaved road to the highest standards, significant quantities of relatively good quality (preferably potable) water are required for compaction. It is often difficult to justify this use of large volumes of water when local communities are spending much energy acquiring quality water for their daily needs.



## 11.2 Sustainability Options

Sustainability issues related to construction materials essentially revolve around minimizing the use of virgin soil and rock materials that are either limited locally or could be more beneficially used for other construction purposes at a later stage. Unlike minerals that are generally of limited extent and are mined to fulfil specific human needs, soils and rock for construction are generally considered to be ubiquitous. Experience in South Africa, for example, has shown that the injudicious use of certain selected construction materials (particularly pedocretes) has almost led to their depletion and materials of a lesser quality now need to be utilized in their place (Paige-Green 2011). In the case of unsealed roads, this has led to poorer performance and higher road user costs as well as aspects such as increased dustiness, erosion and gravel replacement frequencies.

As discussed generally above, a 6 m wide unsealed road typically requires about 900 m<sup>3</sup> of selected wearing course gravel per kilometre (compacted in a 150 mm thick layer) with specific properties to ensure optimum performance. The gravel surface on such a road carrying about 200 vehicles per day would normally last about 6 or 7 years (perhaps up to 10 years depending on the material properties) before it is lost by abrasion, whip-off, erosion or blown away and requires replacement. The material that is lost ends up as dust on vehicles, vegetation and in rivers, as eroded material in water courses and as non-reusable segregated material along the edge of the road.

A more sustainable option would thus be to provide a bituminous seal which would preserve the material for a period of at least 20 years after which time it could be reused (recycled) as a new structural layer in the rehabilitated road as discussed later.

Even for paved roads, a number of more sustainable alternatives exist. The prize option would be to use existing waste materials in the area such as mine wastes that are present locally. These are often widely available and although they may have specific problems (e.g. high sulphide or salt contents), these can usually be overcome using appropriate construction techniques.

The use of thinner pavement layers constructed of higher quality materials instead of thick lower quality layers can also have sustainability benefits, requiring less imported material. The identification of locally available marginal quality materials that can be treated with cementitious, bituminous or possible certain proprietary stabilizers should also be considered.

For lightly trafficked roads, the use of bituminous sand seals constructed using suitable sands extracted from large, mostly intermittent, rivers can be considered as a sustainable option. Such sands are replenished each year during flooding of the river (they are thus arguably considered as renewable resources) and can of ten be successfully used instead of conventional aggregates that require mining, crushing and screening of rock aggregate.

A common problem observed is the construction of excessively wide road pavements. Where materials are scarce, recommendations should be made regarding a



possible reduction in the road width—a 7 m wide road would reduce the material requirements by more than 20 %, for instance over a 9 m wide road.

Greater consideration should also be taken in areas of limited high quality road construction gravels to design highways such that they can be effectively maintained without requiring significant additional materials over a 40 or 50 year period instead of the current practice of designing the road to “fail” and be either reconstructed or require significant rehabilitation every 15 or 20 years. Those materials that are more likely to be successfully recycled in future (e.g. quartzitic gravels) should be proposed for use rather than those materials that are likely to be subjected to decomposition (e.g. basic crystalline rocks) and disintegration (e.g. sandstones and gneisses).

During road construction, the quality of the rock being removed from cuttings and its potential for use as road or concrete aggregate or other construction materials should always be assessed and noted, such that as much of the material extracted as possible can be used for other aspects of the project. These materials should preferably be targeted for replacing high quality materials in the more expensive pavement layers (asphalt, crushed stone base or concrete). Recommendations on the use of different construction techniques (e.g. light versus heavy blasting or ripping) to optimize the type of material produced should also be considered.

In order to optimize the benefits and sustainability it is essential that the geo-technical investigator and designer have a common understanding of the needs, alternatives and specific characteristics of the pavement for which engineering geological investigations are being carried out so that specific attention can be applied to sustainability issues.

### 11.3 Gravel Loss from Unpaved Roads

The actual loss of gravel from a road depends on a number of factors and various models have been developed to estimate this loss. Factors such as traffic and precipitation probably have the dominant effect, but the properties of the material used for construction of the gravel wearing course also play an important role. One of the most popular models to predict gravel loss is that included in the World Bank/PIARC Highway Development and Management system (HDM 4 2000).

This model (HDM 4 2000) includes a number of material, climatic, traffic and road geometry parameters to predict the annual material loss (MLA in mm/year) as shown in Eqs. 11.1 and 11.2. This model can have calibration factors built in for local conditions (Bennett and Paterson 2000).

$$MLA = Kgl3.65(3.46 + 2.46 * MMP * RF * 10 - 4 + KT * AADT) \quad (11.1)$$

where

MLA is the predicted annual material loss (mm/year), RF is the average vertical gradient of the road (%), MMP is the mean monthly precipitation (mm/month), AADT is the annual average daily traffic (vehicles/day), KT is the traffic induced material whip-off coefficient, and Kgl is the local material loss calibration factor.

$$KT = Kkt * \text{MAX} [0, 0.022 + 0.969(HC/57300) + 0.00342(MMP/1000) (P075) - 0.0092(MMP/1000)(PIj) - 0.101(MMP/1000)] \quad (11.2)$$

KT is expressed as a function of rainfall, road geometry, and material characteristics, where, HC is the average horizontal curvature of the road (degrees/km), PIj is the plasticity index of material, P075 is the amount of material passing the 0.075 mm sieve, and Kkt is the traffic induced material whip-off calibration factor.

Another model used to predict gravel loss in southern Africa (Paige-Green 1989) includes similar parameters for the annual material loss (AGL in mm/year) as shown in Eq. 11.3.

$$AGL = 3.65[ADT(0.059 + 0.0027N - 0.0006P26) - 0.367N - 0.0014PF + 0.0474P26] \quad (11.3)$$

where,

ADT is the average daily traffic in both directions, N is the Weinert N-value, which ranges from 1 in wet areas to more than 10 in arid areas and incorporates annual precipitation and evaporation, P26 is the percentage passing the 26.5 mm sieve, and PF is the product of plastic limit and percentage passing the 0.075 mm sieve. The best prediction model for this data did not include the road geometry (although the radius of curvature and grade were part of the data set analysed) nor maintenance practices.

Various other models (Visser 1981; Jones 1984; Giummarra et al. 2007; Henning et al. 2008) have been developed for local application in specific countries.

Predictions of the gravel loss on a number of roads carrying negligible volumes of traffic (less than 10 or 15 vehicles per day) indicate that relatively high gravel losses (about 12 mm per annum) still occurred and these losses were attributed to environmental effects. In fact 1 mm of the loss was due to traffic and 11 mm due to rainfall, erosion and wind loss.

## 11.4 Implications

As stated previously, the material generated from unpaved roads finds its way into the atmosphere and water courses resulting in air pollution, increased siltation of small dams and blockage of underground and surface services in urban areas.

Many other consequences (not related to the road use or user) that have not been fully examined or researched occur as a result of airborne dust: These include:

- The possibility of chest and lung problems in communities living or active close to unpaved roads.
- The discomfort and unknown effects of the presence of excess dust in homes, clinics, schools and other community centres as well as in local water supplies.

- The effects of dust on crops and vegetation adjacent to unpaved roads.
- The effects of dust on livestock adjacent to roads. For example, cases of excessive wear of the teeth of sheep and high mortality rates in chickens adjacent to dusty unpaved roads have been identified.

## 11.5 Possible Solutions

There are various options for mitigating against gravel loss. These include:

- Selecting the most suitable materials;
- Good construction practices and quality control;
- Treatment of the materials with chemical stabilizers; and
- Preserving the layers with a bituminous or concrete surfacing.

However, none of the most effective options are cheap and it is, in fact, highly unlikely that even a small proportion of the world's existing unpaved road network is likely to be treated in any way that will significantly reduce gravel loss. However, attempts at implementing any of these possible options will contribute to reducing material loss and usage.

### 11.5.1 Material Selection

Experience has shown that by selecting the most appropriate materials, the loss of material from the road under traffic and climatic effects can be minimised. An extensive investigation into the performance of unpaved roads (Paige-Green 1989; CSRA 1990) yielded a performance-related specification to optimise riding quality and minimise road user costs, that has been widely implemented in South Africa and many other countries with exceptional results (van Zyl et al. 2007). This specification necessitates that both particle size distribution and cohesiveness (plasticity) requirements are fulfilled, together with various material and aggregate strength limits (Table 11.1 and Fig. 11.1).

However, although the performance criteria such as “erodible”, “corrugates” and “ravels” as shown in Zones A, B and C are indicative of materials with a potential for high material losses, the parameters used for material selection do not necessarily minimise gravel loss. In fact, materials with a large percentage of aggregate between 37.5 and 100 mm have significantly lower annual gravel losses, but result in extremely poor riding quality and high vehicle operating costs. They are also difficult to maintain effectively using routine grader balding. A compromise therefore needs to be achieved based on Fig. 11.1 which is the main priority in terms of providing a cost-effective road but adjusting these properties as far as possible to ensure sustainability.

**Table 11.1** Summary of material requirements for unpaved wearing courses (Paige-Green 1989)

Property	Specification limits
Maximum size	37.5 mm
Oversize index <sup>a</sup>	≤5 %
Shrinkage product <sup>b</sup>	100–365 (preferably < 240)
Grading coefficient <sup>c</sup>	16–34
CBR	≥15 % at 95 % AASHTO T180 maximum dry density

<sup>a</sup> Oversize index = Percentage retained on 37.5 mm sieve

<sup>b</sup> Shrinkage product = Linear shrinkage × percentage passing 0.425 mm sieve

<sup>c</sup> Grading coefficient = (Percentage passing 26.5 mm–percentage passing 2.0 mm) × percentage passing 475 mm sieve/100

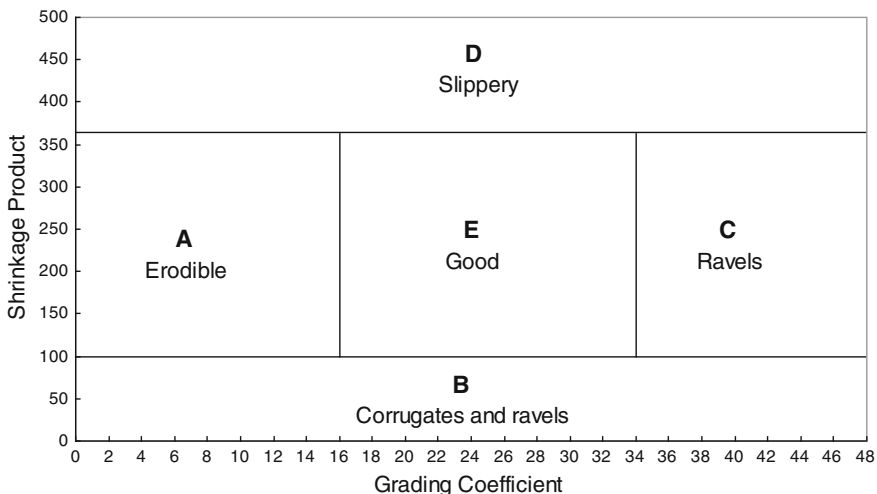
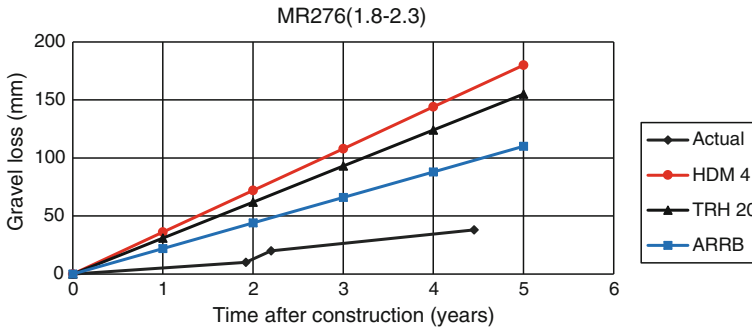

**Fig. 11.1** Material selection and performance criteria (Paige-Green 1989)

### 11.5.2 Good Construction Practice

Implementation of the material specifications and construction guidelines recommended in TRH 20 (CSRA 1990) has resulted in a vast reduction in the maintenance requirements for unpaved roads. This includes a significant reduction in the gravel loss from the roads, related to both a reduction in traffic and environmental losses as well as innovations in the maintenance techniques that reduce gravel losses.

When the optimum materials are selected, according to Table 11.1 and Fig. 11.1, and the materials are processed in order to reduce the quantity and dimensions of oversize material the riding quality has been found to improve significantly and the rate of deterioration of the riding quality decreases. The additional cost of removing oversize materials (by screening, crushing or a combination of the two) is rapidly



**Fig. 11.2** Plot of actual versus predicted gravel loss for a road carrying up to 350 vpd (van Zyl et al. 2007)

recovered in reduced road user costs. In addition, if the recommendations in TRH 20 (CSRA 1990) regarding compaction of the layer are followed, the gravel loss has been found to be reduced by up to 50 % (actual loss in Fig. 11.2 compared with predicted losses using various models).

In addition to the greater care been taken for material selection and processing, a lot of the benefit is achieved by good construction practice. This includes achieving the optimum moisture content (OMC) for the material, spreading it to the correct line and level (making use of string lines) and then compacting it to at least 95 % of the maximum dry density as determined using AASTO T180 (AASHTO 2008). Typical compaction makes use of a tamping roller followed by a vibrating steel drum roller (at least 12 tonnes) or a large pneumatic tyred roller (>20 tonnes). If grid rolling is used to break down some of the softer materials, this should always be followed by ripping and mixing of the layer in order to ensure that the broken particles are separated and do not remain in the layer as a broken but effectively single particle.

Thus by selecting the best materials, processing them to meet the required specification and constructing the road to the highest standards, the inevitable gravel loss can be significantly reduced. The additional costs involved in the construction are easily recovered in terms of the total life-cycle costs of the road.

### 11.5.3 Material Treatment

The treatment (stabilization) of materials in order to reduce the gravel loss has been investigated widely in recent years. This can be done using conventional soil stabilizers (lime, cement or bitumen) or by using some of the wide range of proprietary soil stabilizers currently on the market.

### 11.5.3.1 Conventional Stabilizers

The use of conventional stabilizers has had mixed results. There is no doubt that lime or cement stabilization strengthens the relevant soils significantly. However, both of these stabilizers produce calcium silicate hydrates as the reaction product and need a residual calcium hydroxide (hydrated lime— $\text{Ca}(\text{OH})_2$ ) component to retain the pH of the material above about 12.0 in order to maintain the stability of the materials produced. In the unpaved road scenario, the surface of the layer is exposed to the atmosphere as well as continual changes in humidity and moisture content. These conditions are perfect for the carbonation of the free lime which returns to its original form ( $\text{CaCO}_3$ ) with a reduction in pH, at which point the stabilization reaction products become unstable and break down.

When used for unpaved roads, the result is a weakening of the road surface material, the generation of the fine materials as well as the calcium carbonate that has formed, as thick clouds of white dust and unsafe driving conditions. In addition, the stabilized layer becomes relatively stiff and brittle, which makes it difficult to maintain using conventional grader methods. The layer soon becomes uneven, and unmaintainable, resulting in the need for reconstruction, with a material that now has lost any cohesion that it had prior to stabilization.

A number of the proprietary soil stabilizers are cement based and similar results have been seen with such products, especially when the application rate is in excess of about 3.5 or 4 % stabilizer. No successful projects using lime, cement or cement-based products have been observed by the author.

The use of bitumen too has had mixed results, but some successful projects have been achieved. Bitumen can be used either in the form of bitumen emulsion or as a foamed bitumen. Both of these products have been developed to assist with the spreading and mixing of the bitumen into the material and they can be applied using conventional grader or plough mixing or using purpose-built recycling machines. The latter have been seen to be more consistent in terms of the depth control and mixing, provided experienced operators and controllers are used. The main objective is to achieve uniform mixes and good “joins” between adjacent runs of the equipment.

Unlike cement or lime, where the soil particles are bonded to each other by chemical reaction products, bitumen treatment essentially glues the individual soil and aggregate particles together with a thermo-elasto-plastic adhesive. It is thus still possible to carry out routine grader maintenance on bitumen treated roads. Recent monitoring and observation of bitumen treated road experiments by the author have shown that the gravel loss can be significantly reduced.

### 11.5.3.2 Non-traditional Soil Stabilizers

Over the last 3 or 4 decades there has been a proliferation of proprietary soil stabilizers aimed at treating in situ or local materials as structural layers or wearing courses for unpaved roads.

In excess of 100 such products are or have been being marketed internationally, with mixed success. Despite the number of these chemicals and their aggressive marketing, little independent research has been carried out on their use and benefits. One of the problems in this regard is the wide range of basic chemical and action that takes place, resulting in each product, or type of products requiring individual investigations. The stabilizers include concentrated liquid chemicals, so called “enzymes”, solid crystals, cement or lime-based products, bitumen based products, natural and synthetic polymers and a host of unknown “chemicals”. It has been very difficult to group many of these into single types but in general the following grouping of the main products can be used (Jones et al. 2013).

### Hygroscopic (or Deliquescent) Materials

These are used mostly for dust palliation but they can have some surface stabilization effects, reducing the gravel loss. Their mechanism of action is the absorption by the chemicals of atmospheric moisture to maintain the road surface in a slightly moist condition and retain the fines by soil suction forces. Reductions in gravel loss as a result of using these chemicals have been noted.

### Natural Non-petroleum Based Organic Polymers and Chemicals

These products are usually obtained as by-products of other industries such as paper pulping, leather tanning, sugar refining, etc., and include lignosulphonates, tannin, molasses and tree resins. Their soil stabilization actions relies on weakly gluing the finer soil particles together. Their main use is as dust palliatives, although they do have a weak soil stabilizing effect and have been seen to reduce gravel loss to some extent. They are highly soluble in water.

### Petroleum Resins

These are usually based on diluted bitumen emulsions. These are often blended with chemical polymers and bind the soil particles together. In principle they should reduce the gravel loss but there is little experience with controlled monitoring to support this.

### Synthetic Polymer Emulsions

These products are manufactured as by-products of the petro-chemical industry and consist of monomers that are polymerised in an aqueous medium. Similar to the “breaking” of bitumen emulsions, once the water evaporates, the residual “glue” binds the soil particles together. A number of investigations into these products

have been carried out but in general, the gluing action is rather weak and the wearing course deteriorates under traffic. Only when high additive contents are used (5 % plus) are benefits in gravel loss reduction realised or for roads carrying very low traffic.

### Mineral Oils

These products include base fluids, mineral oils and formulations of synthetic organic compounds. They are usually used as dust palliatives and little is known about their ability to reduce gravel loss.

### Sulphonated Oils and Electrochemical Products

These are probably the most commonly marketed products, which consist of surfactants that “bind” to certain clay minerals, cause cation exchange and neutralising their deleterious effects on road construction materials. The products depend on the presence of active 2:1 clays (predominantly those of the smectite group) for their effectiveness. Good results have been obtained using some of these chemicals on certain materials, but it is essential that the compatibility of the product with the material to be utilised is confirmed. Table 11.2 shows some results from testing of five soils with a range of these products. The inconsistency of the results is clearly apparent. They are highly concentrated and the effect of small changes in their application rates can also be significant (Paige-Green and Bennett 1993).

### Enzymes

Little information is available on the exact nature of these widely-available products although they are described by the suppliers as being a catalyst that assists in neutralising the deleterious effects of clay on construction materials. Their material requirements and application rates and processes are generally identical to sulphonated oils.

**Table 11.2** Effects of different ionic soil stabilizers on the CBR of various soils

Material/Product	Diabase	Black clay	CBR (%) laterite	Chert	Shale
Untreated	32	2	181	51	33
Product B	76	2	137	39	42
Product G	65	2	144	41	37
Product C	72	–	–	85	45
Product D	69	–	–	46	38



## Cement and Lime-Based Products

A number of products have appeared on the market that are based on traditional cementitious stabilizers but have various chemicals, additives or “fibres” added to reduce volume changes and shrinkage and increase flexibility. Their behaviour on unpaved roads, however, is expected to be similar to the use of conventional cement or lime. No additives to inhibit or reduce carbonation are apparently included in their formulation.

### 11.5.3.3 Use of Non-traditional Soil Stabilizers

The use of the non-traditional soil stabilizers will depend on the objective of the stabilization—whether they are to increase the strength or modify the properties of the construction material or solely to reduce the generation of dust from unpaved roads. Any reduction in the loss of gravel from a road can be considered as a bonus.

Various full-scale experimental sections using different stabilizers designed to assess methods of reducing gravel loss in a large nature conservation area where gravels are becoming problematic to obtain have been carried out recently. The only technique that showed any promise with the specific materials (a low plasticity weathered granite and a moderately plastic weathered basalt) was the use of bitumen emulsion.

If any non-traditional stabilization products are considered or shown to be viable, their application to reduce gravel loss from unpaved roads can be beneficial both technically and economically, but a balance needs to be obtained between the two. Numerous examples of effective use of such products have been observed although very little has been written up or published.

Unfortunately, it is difficult to simulate gravel loss (by abrasion or erosion) in the laboratory and only properly controlled and monitored full scale field trials can provide adequate answers.

The possible use of such products must be considered in line with good engineering knowledge and experience as well as a high degree of “engineering judgment”. Many of the products are marketed on the premise that they can be used to treat the upper 150 or 200 mm of in situ materials and thus produce a “strong, durable road” that will carry, for example, 400 tonne mine trucks for 20 years or millions of standard axles. This will not be the case for unpaved roads where natural and traffic attrition will continue to abrade the road.

## 11.5.4 Surfacing

Irrespective of the treatments applied to unpaved roads, the roads remain unpaved with direct frictional abrasion under tyres, traffic loads and wind and water effects. The loss of gravel could possibly be reduced as discussed above, but the roads

remain unpaved and will continue to lose material with time, albeit possibly at a reduced rate.

Application of a bitumen or concrete surface that is in contact with traffic and the environment is the only real long-term method of isolating the material pavement gravel from these abrasive agents.

Life cycle cost analyses can be carried out to determine the break-even traffic count at which it is economically viable to pave or upgrade the unpaved road. These analyses, however, are purely based on the road agency costs (construction, maintenance and regravelling) and the road user costs (vehicle operating, time and safety). No account is generally taken of the social, environmental or sustainability costs.

Techniques for assessing social costs are being developed and it is possible to put a value to environmental costs that may directly affect communities, for example, the effects of dust, pollution of water, etc. However, the sustainability costs are a much larger problem (Paige-Green 2011). All natural materials have an intrinsic value in nature and once removed and placed on a road, they cannot be replaced. Taxes such as nominal aggregate taxes as used in certain countries do attempt to place a value on these materials in terms of their sustainability—it can never be compared with a replacement value, for instance. Different materials in different topographic, geological or geomorphic environments will have different values, depending on such characteristics as their permeability or porosity, their nutrients for plant growth or agricultural use, their mineral constituents (it is not possible to know which minerals may become important or economically significant in future), etc.

In order to make paved roads more cost-effective, they need to be built at costs considerably less than conventional pavement structures. Generally, the upgrading of unpaved to paved roads will be at relatively low traffic counts and the pavement structures can be thinner and make use of lower standard local materials than conventionally used. Designs should also make the optimum use of the expected in situ moisture regimes (Gourley and Greening 1999; Pinard and Paige-Green 2013). Considerable work in this area has been carried out recently and is reported elsewhere (Paige-Green and Pinard 2012; Pinard and Paige-Green 2013).

The use of these appropriate pavement structures should be combined with more appropriate surfacing types and these have been well documented (Sabita 2012). Bituminous surfacings using local materials such as graded aggregates in Otta seals (Overby 1999) and river sands in sand seals (Louw and Schoeman 2004), have been shown to perform extremely well on such low volume roads.

There will always be areas where concrete roads are the only practical solution, particularly on steep grades and adjacent to low water crossings. This type of road, although costly cannot be ignored. Concrete roads are also extremely suitable for labour based construction and maintenance.

## 11.6 Water Usage

Every time an unpaved road is regravelled, ripped and recompactd or often even heavily bladed using a motor grader, water is required to assist compaction of the layer.

Like the materials used for unpaved wearing courses, water used for construction can be classified as a non-renewable material, as water resource depletion can occur rapidly, particularly in drier areas. Although the normal hydrological cycle will ultimately return much of the construction water used to the soil, this takes time and can affect local groundwater usage, as well as possibly resulting in contamination of the water.

Water is a precious resource, and this is nowhere more notable in rural semi-arid to arid areas, where a large proportion of the daily energy use of the communities is dedicated to acquiring and transporting water for household use.

The compaction of a typical unpaved road requires that the material should be at or close to the optimum moisture content for that material. Good unpaved wearing course gravels, by their nature, have some plasticity, which increases the optimum moisture content required for their successful compaction and thus necessitates a somewhat larger need for compaction water. In broad terms, effective compaction typically requires the use of about 200 l of water per cubic metre of material (or between 150 and 200 thousand litres of water per 150 mm thick layer per kilometre of material constructed). The amount of water required to reach OMC is increased more so in arid areas where the natural moisture content of soil is very low and high temperatures result in a significant loss of water by evaporation during the mixing and compaction process. Thus in semi-arid and arid areas the cost of supplying water for construction projects has been known to comprise up to 25 % of the total construction cost.

Thornthwaite's Moisture Index is a useful indicator of the quantity of water in the ground, with any value of less than zero indicating that more water is lost annually by evapotranspiration than is admitted to the ground (soil) from precipitation. In other words, in these areas, unless the groundwater is augmented by streams or distant water resources (highly unlikely), the water table will drop with time and water used for construction will exacerbate this drop. The injudicious use of water during construction can thus result in the local depletion of a natural resource.

Figure 11.3 shows a generalised map of the semi-arid and arid areas of the world indicating those areas with an annual water deficiency. It can be seen that the majority of Africa, Australia, the Middle East and western Asiaas well as large parts of the western areas of North and South America fall within the arid areas of Thornthwaite's map (Thornthwaite 1948; Meigs 1953). Over 40% of the earth's land area is thus arid and one third of the world's population lives in these arid areas (MEA 2005). The upgrading, construction and maintenance of infrastructure in these arid areas is therefore unavoidable., The likely increase in the extent of arid areas as a result of global climate change is expected to compound these problems.

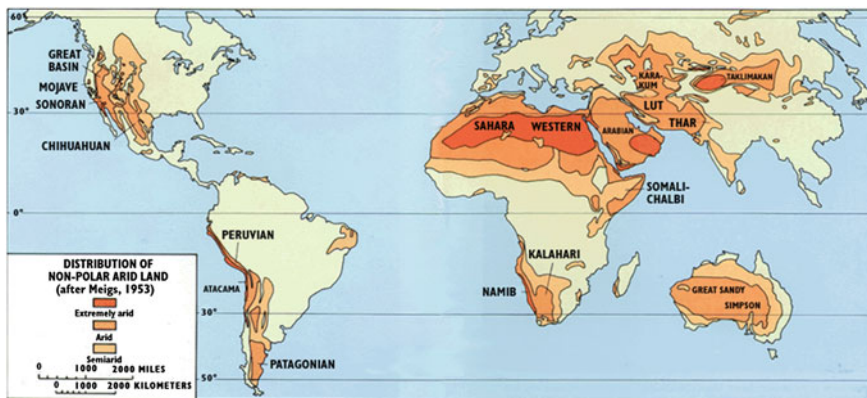

**Fig. 11.3** Map showing arid areas classified according to Thornthwaite’s moisture index (Source <http://pubs.usgs.gov/gip/deserts/what/world.html>)

Research and experience have shown that alternative methodologies can be used to reduce the impact of road construction on water resources (Leyland and Paige-Green 2009). These include, for instance, the use of a road recycler for application of the water and mixing of the material which requires less water than conventional construction, the potential use of nano-materials to change the structure of materials to enable the effective use of non-potable water and the use of innovative techniques to allow soil compaction at low moisture contents. Although many of these techniques still require research and refinement it is important that the construction industry as a whole becomes aware of the problem and begins to review current construction practices.

The consideration of novel techniques should also take into account the energy cost of providing (abstracting, transporting and mixing) potable water in rural areas. The embodied energy of the final product should thus guide the decision regarding optimal construction methods. It would also be a location-specific alternative, as in areas with abundant potable groundwater, it may be more suitable (cost and energy-wise) for conventional wet compaction.

## 11.7 Conclusions

The current practice of using natural gravels and aggregates for the enormous world network of unpaved roads is totally unsustainable with millions of cubic metres of material being extracted from borrow pits annually to replace the material lost from roads by traffic whip-off, erosion and as dust. This material all has to be replaced (typically every 6 to 10 years) in order to ensure all-weather passability of the roads and appropriate levels of comfort for the road users. This requires the exploitation and excavation of large areas of natural landscape to provide these materials,

leaving severe scarring of the countryside and an irreplaceable loss of local material, clearly an unsustainable situation. This chapter summarises the problem and briefly reviews various options for attending to the problem, although costs are likely to prohibit large scale implementation of many of the solutions. Unpaved roads, unless sealed with a bituminous or concrete surfacing will always lose material and the best that can be done is probably to reduce this loss as far as possible.

A similar situation exists over large parts of the world classified as arid where the widespread use of groundwater for construction purposes can also be considered unsustainable. The full consideration of the use of water during construction is ultimately required not only to reduce the impact of construction on water resources but also to optimise the use of the available water and ensure sustainability.

## References

- AASHTO. (2008). *T180: Moisture-density relations of soils using a 4.54 kg (10 lb) rammer and a 457 mm (18 in.) drop*. Washington, DC: American Association of State Highway and Transportation Officials.
- Bennett, C. R., Paterson, W. D. O. (2000). A guide to calibration and adaptation. In: The highway development and management series. international study of highway development and management (Vol. 5). Paris: World Road Congress (PIARC).
- Committee of State Road Authorities (CSRA). (1990). The structural design, construction and maintenance of unpaved roads. Draft TRH 20. Pretoria: Department of Transport.
- Giummarra, G. J., Martin, T., Hoque, Z., Roper, R. (2007). Establishing deterioration models for local roads in Australia. *Proceedings of 9<sup>th</sup> International Low Volume Roads Conference, Austin, Texas*. Washington: Transportation Research Board.
- Gourley, C. S., Greening, P. A. K. (1999). *Performance of low volume sealed roads: Results and recommendations from studies in Southern Africa*. Report PR/OSC/167/99. Crowthorne: Transport Research Laboratory.
- Henning, T. F. P., Giummarra, G. J., Roux, D. C. (2008). The development of gravel deterioration models for adoption in a New Zealand gravel road management system. *Land Transport New Zealand research Report 348*. New Zealand: Wellington.
- Highways Development and Management (HDM-4). (2000). *World Road Association* (Vols. 1–5). Paris, Washington, DC: World Bank.
- [http://www.nationmaster.com/graph/tra\\_roa\\_pav\\_of\\_tot\\_roa-transportation-roads-paved-of-total](http://www.nationmaster.com/graph/tra_roa_pav_of_tot_roa-transportation-roads-paved-of-total). Retrieved August 2013.
- <https://www.cia.gov/library/publications/the-world-factbook/fields/2085.html>. Retrieved August 2013.
- <http://pubs.usgs.gov/gip/deserts/what/world.html>. Retrieved August 2013.
- Jones, T. E. (1984). *The Kenya maintenance study on unpaved roads*. TRRL laboratory Report 1111. Crowthorne: TRRL.
- Jones, D., Bolander, P., Paige-Green, P. (2013). *New developments in selecting chemical treatments for gravel roads*. Paper presented at 92nd Transportation Board Annual Meeting, TRB, Washington.
- Leyland, R., Paige-Green, P. (2009). *Minimising groundwater extraction for infrastructure construction*. Proceedings of Ground Water Conference. Retrieved November 2009. Stellenbosch.
- Louw, K., Schoeman, S. (2004). Performance of sand seals in the Kruger National Park. *Proceedings of 8th Conference Asphalt Pavements for Southern Africa* (pp. 906–913). South Africa: Sun City.

- Meigs, P. (1953). World distribution of arid and semi-arid homoclimates. In *UNESCO: Reviews of research on arid zone hydrology* (pp. 203–201). Paris: UNESCO.
- MEA (Millennium Ecosystem Assessment) (2005). *Ecosystems and Human Well-being: Wetlands and Water Synthesis*. Washington, DC: World Resources Institute.
- Overby, C. (1999). *A guide to the use of Otta Seals*. Oslo, Norway: Publication 93, Directorate of Public Roads.
- Paige-Green, P. (1989). The influence of geotechnical properties on the performance of gravel wearing course material. PhD Thesis, University of Pretoria.
- Paige-Green, P. (2011). Sustainability issues related to the engineering geology of long linear developments. *Journal of Mountain Science*, 8(2), 321–327.
- Paige-Green, P., Bennett, H. (1993). The use of sulphonated petroleum products in roads: State of the art. *Proceedings Annual Transportation Convention* (Vol. 4C), Pretoria.
- Paige-Green, P., Pinard, M. I. (2012). Optimum design of sustainable sealed low volume roads using the Dynamic Cone Penetrometer (DCP). *Proceedings 25th ARRB Conference*. Perth, Australia.
- Pinard, M. I., Paige-Green, P. (2013). A new approach for the optimal design of sealed low volume roads using the Dynamic Cone Penetrometer (DCP). *6th Africa Transportation Technology Transfer (T2) Conference* (pp. 187–203). Botswana: Gaborone. March 2013.
- Sabita (2012). *Bituminous surfacings for low volume roads and temporary deviations*. Manual 10, South African Bitumen Association (Sabita), Cape Town.
- Thornthwaite, C. W. (1948). An approach toward a rational classification of climate. *Geographical Review*, 38(1), 55–94.
- van Zyl, G., Henderson, M., Uys, R. (2007). Applicability of existing gravel road deterioration models questioned. *9<sup>th</sup> International Conference on Low-Volume Roads*, Austin, Texas, June 2007.
- Visser, A. T. (1981). An evaluation of unpaved road performance and maintenance. PhD Thesis, University of Texas, Austin.

# Chapter 12

## Sustainable Airport Pavements

Dominique M. Pittenger

**Abstract** Sustainability is increasingly becoming a priority issue, as well as the foundation for future prosperity, in the global aviation community. Pavement structures are an airport's greatest asset and greatest liability, and along with their associated management systems, involve an intensive, expensive enterprise and consume massive amounts of nonrenewable resources at every airport. Pavement sustainability includes assessing various pavement strategies on the basis of economic, environmental, operational and societal impact throughout the pavement's life cycle. Getting the most benefit for the least cost is a key attribute of pavement sustainability. This chapter presents an overview of the practices that are fundamental to sustainable airside pavements, as well as some of the life cycle considerations. It includes pavement topics such as pavement condition, treatment types, traffic and climate, as well as life cycle cost, life cycle emissions and energy use and pavement management.

### 12.1 Introduction

Airports are a significant contributor to the global economy and play a key and increasing role in moving people and goods (Federal Aviation Administration (FAA) 2012). However, the aviation industry is challenged to meet the growing demand because of shrinking budgets, limited resources and aging infrastructure issues, like those associated with airport pavements (Shafer and 2012; Eagan et al. 2009). Sustainability, which can address these issues, has been identified as being a critical issue in aviation (Eagan et al. 2009). Airports have been implementing a number of sustainable practices consistently over the last few decades (Eagan et al. 2009; Berry et al. 2008; Aviation Industry Commitment to Action on Climate Change 2008; Introduction to Sustainability 2010; Going Greener 2010). However,

---

D.M. Pittenger (✉)

College of Engineering, University of Oklahoma, 202 West Boyd Street,  
Norman, OK 73019, USA  
e-mail: dominiquep@ou.edu

progress in sustainability implementation is increasingly being demanded due to the current level of public scrutiny and airport policy and regulation (Eagan et al. 2009; Berry et al. 2008; Aviation Industry Commitment to Action on Climate Change 2008; Introduction to Sustainability 2010; Going Greener 2010; Ricondo Associates Inc. et al. 2011). Stakeholder concerns and the global push for sustainability have added a sense of urgency (Eagan et al. 2009; Berry et al. 2008; Aviation Industry Commitment to Action on Climate Change 2008; Sustainable Aviation Guidance Alliance 2010; Airports Council International—North America 2010).

Sustainability progress is also becoming a priority to airport owners and operators because of the cost effectiveness benefit derived from sustainable approaches (Touran et al. 2009). The Air Transport Action Group's (ATAG) attributes some of the improvements in aviation environmental performance to greater operational efficiency, an important sustainability factor for airport owners and operators (Eagan et al. 2009; 2010). The Greater Toronto Airports Authority goal, for example, is to increase operational efficiency (profit) while maintaining safety and environmental practices, whereby gaining competitive advantage (2010).

*Sustainability* has not been universally defined by the aviation community. Airport pavement sustainability generally involves consideration of the net benefit of interrelated environmental, economic, operational and societal impacts of decisions and activities that occur in every phase of the pavement life cycle (Eagan et al. 2009; Berry et al. 2008; Ricondo Associates Inc. et al. 2011). For example, the ATAG *Aviation Industry Commitment to Action on Climate Change* document calls for implementing greenhouse gas reduction measures “wherever they are cost-effective” (Aviation Industry Commitment to Action on Climate Change 2008). Getting the most benefit for the least cost over the pavement life cycle is a key attribute of pavement sustainability.

## 12.2 Airport Pavement

Pavement represents an airport's greatest asset and greatest liability and therefore represents a considerable portion of research and funding in this area (AirTap 2005). Much of the US Federal Aviation Administration (FAA) Research and Development funding supports research “to improve the design, construction, rehabilitation, and repair of airfield pavements to aid in the development of safer, more cost effective, and more durable airfield pavements” (Federal Aviation Administration (FAA) 2010a). Pavement advancement in the highway sector provides a valuable resource to the aviation community; however, there are managerial, engineering and operational issues that are unique to airport pavements that must be considered for sustainability (Applied Research Associates Inc 2011; Hajj et al. 2008; Hanson et al. 2009). This chapter will focus on airport-specific and airside-pavement-specific topics.

Increasing traffic demand is a sustainability challenge because it is resulting in airside congestion and costly user delay (USDOT 2001; Loizos et al. 2006).



Pavement load type is also evolving due to new generation aircraft and associated complex gear loading configurations, impacting pavement design and management (Loizos et al. 2006; Rangan Gopalakrishnan and Thompson 2006). An implementation challenge for some sustainable activities is that historical methods and specifications have not fully evolved with airport pavement sustainability (Loizos et al. 2006; Rangan Gopalakrishnan and Thompson 2006; Muench et al. 2010). Preserving and maintaining aging pavement assets are also sustainability imperatives (Wade et al. 2001; Galehouse et al. 2003; Vreedenburgh 1999; Galehouse 2010). Airfield pavement deterioration and distresses are caused primarily by weathering, but also aircraft traffic (Hanson et al. 2009). Airside pavements are also exposed to jet fuel, jet blast and deicing agents. An important concern of airport pavement engineers is the potential for foreign object debris (FOD) due to delamination, which increases with pavement age and can cause aircraft damage and lead to in-flight catastrophic failure (i.e. airplane crashes) and loss of life (Federal Aviation Administration (FAA) 2010b).

Additionally, airports have unique business structures and management strategies and vary greatly in size and service. They are publicly and/or privately owned and are regulated by various agencies. Therefore, funding and regulatory mechanisms for capital development/improvement and asset management vastly differ, impacting the manner in which airport pavements are planned, designed, constructed and maintained.

### 12.3 Fundamental Elements of Pavement Sustainability

Substantial effort has been put forth by government, industry and academia in the global community to quantify sustainability. Sustainability frameworks and rating/reporting systems have been disseminated and implemented (Muench et al. 2010; Chicago Department of Aviation 2011; Mukherjee and Cass 2012; Zietsman et al. 2011). Tools and frameworks, such as life cycle cost analysis and life cycle assessment models are being developed to assist in decision justification (Muench et al. 2010; Pittenger 2011). At the time of this writing, there are no standard tools being used throughout the aviation community to assess pavement sustainability. Although the results of the global effort to quantify sustainability are often discipline-specific and limited in their application across sectors, they do provide a plethora of resources to enable airport owners and operators make progress towards sustainability and organizational goals.

There are practices that are collectively considered fundamental to pavement sustainability (Muench et al. 2010), and eight are specifically applicable to airside pavements (Pittenger 2011), as shown in Fig. 12.1. Three practices involve information gathering and analysis during the planning and design phases to support decision making. The remaining practices involve creating and executing strategies to manage and maintain pavements throughout the pavement life cycle.



**Fig. 12.1** Fundamental practices for pavement life cycle sustainability

Collectively, the practices support the evaluation and implementation of sustainable activities that yield cost effective pavement durability based upon the net benefit between the sustainability elements. The process of managing these life cycle activities is intended to be iterative for the purpose of continuously improving pavement sustainability within an organization (Chicago Department of Aviation 2011). Implementation of these activities can allow airports to address sustainability needs, regulatory requirements and enhance stewardship and customer relations (Berry et al. 2008).

### ***12.3.1 Decision Making Sustainability Fundamentals***

Three sustainability fundamentals involve information gathering and analysis during the planning and design phases. They include life cycle cost analysis (LCCA), life cycle assessment (LCA) and environmental review. They collectively contribute to informed decision making by providing a means to assess a pavement project's sustainability (Muench et al. 2010).

#### **12.3.1.1 Life Cycle Cost Analysis**

The fundamental premise of economic evaluation of pavement projects is that selection is constrained by available funding (Sinha and Labi 2007). Some airports

implement LCCA in the decision making process (Pittenger 2011). Because of the considerable investments airports have in their pavements, “the potential savings from following a cost-effective approach to meeting an agency’s performance objectives for pavements are significant” (Peshkin et al. 2004). Economic analysis, specifically LCCA, is a sustainable approach to assessing pavement projects that can allow airports to stretch the budget by spending limited funds more effectively (Sinha and Labi 2007). Use of LCCA “will undoubtedly continue to grow as long as the public and policy makers demand better management of scarce resources in the long run” (Ozbay et al. 2004).

LCCA requires various input data, including pavement costs and performance data, like the type of data contained in an airport pavement management system (APMS), which is discussed in a later section. An example of LCCA mechanics for asphalt pavement is shown in Fig. 12.2. Facilitating LCCA with localized pavement performance data may reduce the level of inherent uncertainty associated with service life assumptions and can yield insight to an alternative’s performance and cost-effectiveness (Reigle and Zaniewski 2002). If actual airport pavement data is not considered when determining cost-effectiveness, the results may be biased (Bilal et al. 2009).

Operational and societal sustainability issues are often difficult to quantify, but can contribute to the value of LCCA output (Applied Research Associates Inc 2011; Pittenger 2011; Bilal et al. 2009). Although very little guidance exists on airport LCCA, it has been suggested that user costs be incorporated into analyses by quantifying operational delays (Applied Research Associates Inc 2011; Pittenger 2011). These user costs could vary greatly depending upon factors such as airport

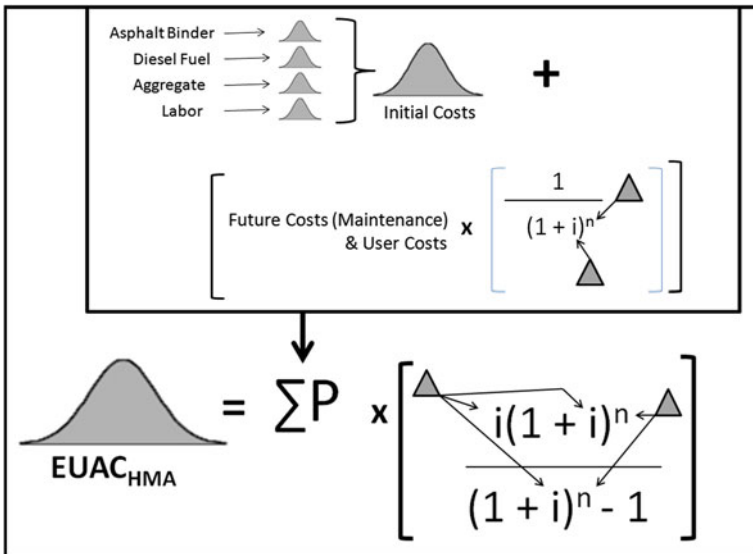

Fig. 12.2 Life cycle cost analysis example: equivalent uniform annual cost (EUAC)

size, time of day, pavement location or construction paving sequence. For example, pavement construction or maintenance activities scheduled during night hours or on a non-primary pavement may have little associated operational disturbance and may not justify any user costs being included in the LCCA. Furthermore, excluding user costs in these cases may be appropriate if it skews the analysis so that the pavement alternative with the least short-term inconvenience is preferred over the better long-term solution, undermining LCCA objectives (Gransberg and Scheepbouwer 2010). However, if the operational disturbance is significant, then user costs should be quantified and included in the analysis. An airport shut down one of its two runways for reconstruction and quantified the total operational impact on the airlines at \$30,000 per hour (Duval 2007). This value should be used in the LCCA because it would significantly impact the output if the pavement alternatives being considered had varying construction durations. This type of analysis may provide the justification necessary to select a higher priced accelerated construction technique over a traditional one (Peshkin et al. 2006).

LCCA output can potentially demonstrate net benefit and could provide justification for selecting an alternative on the basis of sustainability rather than just lowest initial cost. Results should be coupled with other factors such as “risk, available budgets, and political and environmental concerns” (U.S. Department of Transportation Federal Highway Administration Office of Asset Management (FHWA) 2002). For example, LCCA and life cycle assessment (LCA) results can be coupled to furnish the pavement engineer crucial insight about a pavement’s life cycle impact (Rangan Gopalakrishnan and Thompson 2006).

### 12.3.1.2 Life Cycle Assessment

A life cycle assessment (LCA) is a cradle-to-grave approach to quantifying material flow, emissions and energy consumption of processes and systems. ISO 14040 offers guidance on conducting life cycle assessments. Although this process would provide relative environmental impact of alternatives being considered, there are currently no standard models for airport pavement engineers to use (Pittenger 2011). A study’s survey results indicated that airports were not conducting this type of analysis (Pittenger 2011). Additionally, there is currently no literature regarding airport LCA use.

Various LCA models and methodologies do exist in other industries (Muench et al. 2010). Data from life cycle inventory databases could serve to supply analysis input values (Muench et al. 2010). The aviation industry is also quantifying airport energy and emissions data to create inventories that could support airport LCA. Calculators are available to assess individual pavement project impacts from material extrusion to installation. This type of quantifiable information could potentially justify funding for the sustainable design and construction practices that the aviation community is seeking to implement (Pittenger 2011).

### **12.3.1.3 Environmental Review Process**

The objective of the environmental review process is to evaluate the impact of a given pavement project to facilitate decision making (USDOT 2001). Environmental assessments may have to be conducted by some airports to meet regulatory requirements (USDOT 2001). A comprehensive review yields detailed information on all potential impacts, including environmental, economic, societal and operational impacts for the pavement project at hand (Muench et al. 2010). Specifically, the process seeks to determine and document the types and extents of impacts (Muench et al. 2010). This qualitative process compliments the two quantitative processes, LCCA and LCA. They collectively contribute to informed decision making by providing pavement engineers a means to assess a pavement project's sustainability (Muench et al. 2010).

### ***12.3.2 Project Execution Sustainability Fundamentals***

The fundamental sustainability practices that address pavement durability via contractor-developed plans are already in place at many airports (Pittenger 2011). The goal of these plans is to address construction quality, waste handling and pollution prevention, consistent with specifications and regulatory requirements where applicable. Pavement durability is an important element of pavement sustainability. The goal of the quality control plan is to ensure pavement durability through proper workmanship and materials. The plan involves defining quality for each item of work, assigning roles for quality management and monitoring construction quality through inspection and testing. The goal of the waste management plan is to divert construction/demolition waste from landfills. It essentially outlines the various types of waste expected to be generated from a pavement project, as well as strategies for disposal or recycle/reuse. The pollution prevention plan is often a regulatory requirement and addresses materials and procedures for preventing pollution stemming from construction activities. Activities include items such as installation, inspection and maintenance of erosion control measures to control sedimentation and pollution of storm water discharge.

### ***12.3.3 Pavement Management Sustainability Fundamentals***

Two sustainability fundamentals involve pavement management during the operations and maintenance (O&M) phase. They include having a site maintenance plan and an airport pavement management system (APMS) in place.

### 12.3.3.1 Site Maintenance Plan

A site maintenance plan is fundamental to pavement sustainability because it provides strategies and procedures for ensuring specified levels of service and safety for airside pavements. There is no uniform airport site maintenance plan, however, airports do have and implement various plans to cover the essential elements (Chicago Department of Aviation 2011). Site maintenance includes schedules and inspection frequencies, as well as roles and responsibilities, for maintenance activities. Additionally, it outlines procedures for maintaining navigational aids (NAVAIDs), stormwater management systems, landscaping and erosion control. Additionally, there are provisions for pavement surface monitoring to mitigate precipitation, aircraft tire rubber deposits and FOD.

### 12.3.3.2 Airport Pavement Management System

Having an APMS or program in place is considered fundamental to airport pavement sustainability because it supports preservation of an airport's large pavement investment (Hajek et al. 2011). APMS promotes proactive pavement maintenance to extend a structurally sound pavement's service life (Hajek et al. 2011). Because APMS fosters improvement in airport safety, operational efficiency and effective use of funds, it has been implemented by many airports (Hajek et al. 2011). APMS accommodates network and project level activities and includes an inventory of an airport's pavements. Additionally, each pavement's condition is continuously monitored. The ultimate goal of using an APMS is to "(a) determine pavement [maintenance] needs, (b) optimize the selection of projects and treatments over a multiyear period, and (c) evaluate the long-term impacts of project priorities" (Tighe and Covalt 2008). It includes cost and performance data capturing for pavements and treatments that can be used to predict life cycle cost and remaining service life to prioritize projects and optimize the use of funds, therefore yielding better decisions and justification (Wade et al. 2001). The US Federal Aviation Administration imposes the APMS program requirement as a condition of funding because failing to preserve pavements can result in extensive reconstruction costs. The real value of using a pavement management approach to airport owners and operators is realized through the reduction of operational disturbances and demonstration of return on investment (Peshkin et al. 2004). Because an APMS can contribute to extension of service life of capital assets, it can potentially offset much of its cost (Peshkin et al. 2004).

The APMS will take a more prominent role in pavement management with the emergence of asset management (AM) policies at airports (GHD Inc. 2012). An ISO standard for AM framework is being developed at the time of this writing. The goal of the AM system is to capture asset life cycle cost and technical data for all of an organization's assets and use that data to make rational decisions regarding prioritization of both capital and preventive maintenance project funding (GHD Inc. 2012). Additionally, airports can benefit from "the holistic integration of asset

management processes, practices, and tools across the airport organization (public and private), as a means to improve the return on investment in airport assets and infrastructure, in terms of financial sustainability, risk exposure, and levels of service to customers and stakeholders” (GHD Inc. 2012). An APMS contains the necessary information to support the pavement class in the AM system and justify preventive maintenance and ensure extended pavement service life and level of service on a smaller budget (GHD Inc. 2012).

## 12.4 Airport Pavement Life Cycle Sustainability Considerations

Sustainable practices, strategies and performance metrics for various project life cycle phases are being identified and catalogued and serve as a resource for the aviation community (Berry et al. 2008; Introduction to Sustainability 2010). Although not all practices will be applicable to a specific airport or adhere to local policies and regulatory requirements, each practice can be “evaluated by the user and by selected stakeholders for their suitability” (Touran et al. 2009). A strategic, comprehensive plan can be developed and implemented to support the sustainability goals of an airport, like the City of Chicago’s *Sustainable Airport Manual* (Chicago Department of Aviation 2011). This type of plan should consider pavement sustainability and all phases of the project life cycle.

### 12.4.1 Planning and Design Sustainability Considerations

The power to influence project sustainability is greatest in the planning and design phases. Airport pavements involve an intensive, expensive enterprise and consume massive amounts of nonrenewable resources and energy (Berry et al. 2008; Introduction to Sustainability 2010). For the aviation community, there are resources that catalog methodologies to reduce environmental, economic, operational and societal impact (Berry et al. 2008; Introduction to Sustainability 2010). Selection of appropriate methodologies for a specific airport will be influenced by various organizational and sustainability goals, as well as by policy and regulatory requirements. Items listed in Table 12.1 have been attributed to pavement sustainability during the planning and design phases (Muench et al. 2010; Peshkin et al. 2006; AirTAP 2003; Nowak 2011).

Additionally, sustainability activities at the planning level include reviewing aviation demand forecasts and planning capital improvements to enhance airport operations by maintaining specified levels of service and safety. Airport expansion is a common activity initiated in the planning phase to increase capacity of airports. Zoning issues include both land use and airspace planning (AirTAP 2003). Zoning in and around airside pavements primarily includes requirements to ensure safe

**Table 12.1** Sustainability considerations during planning and design project phases

Consideration	Sustainability benefit
Life cycle cost analysis	Quantify economic/operational impact
Life cycle assessment	Quantify environmental impact
Environmental review process	Quantify sustainability impact
Pavement technologies	Reduce economic/environmental impact
Material resources/recycling	Reduce economic/environmental impact
Climate change adaption	Increase pavement durability
Land use/zoning	Ensure public safety and welfare
Noise control	Ensure public safety and welfare
Light pollution reduction	Ensure public safety and welfare
Stormwater MGMT/erosion control	Reduce environmental impact
Energy alternatives/efficiency	Reduce environmental impact
Emission impact mitigation	Reduce environmental impact
Water use efficiency	Conserve resources
Electronic document submission	Conserve resources (paper)
Outreach and stakeholder plan	Increase awareness

approach and landing operations on runways. Airspace zoning includes consideration of development around the airport, often limiting the height of surrounding buildings to ensure safe aircraft operations (AirTAP 2003). An important sustainable planning activity is to consider zoning in a manner that any future airport expansion would be accommodated under the current ordinances. Considering optimal use of the airfield when designing the geometry of new pavements can enhance sustainability by reducing potential encroachment of existing runway safety zones when work requires adjacent pavement closures (Peshkin et al. 2006; Nowak 2011).

The ultimate goal of the airport pavement engineer is to design a structurally and functionally sufficient airside pavement to support the load rating of the heaviest aircraft expected in the specific climate in which it is being built (Rangan Gopalakrishnan and Thompson 2006). Sustainability strategies support design goals by enhancing durability and safety while reducing cost, operational disturbance and environmental impact. For example, the goal of climate change adaption in design is to employ proper means, materials and methods to mitigate the impact of climate change on the pavement structure and materials so that it can maintain its structural and functional efficacy. However, specifications, policy and regulation can constrain pavement design and often inhibit incorporation of emerging sustainability strategies. But as the viability and safety of these strategies become validated, governing requirements will likely be updated.

Pavement design will have an impact on construction materials and procedures, as well as future maintenance requirements and pavement performance. Therefore, involving construction and O&M personnel during this phase may enhance the design process and make the pavement more sustainable over its life cycle. The pavement design will also impact site drainage. Deicing agents are a major concern for airport



operators because they can contaminate stormwater runoff. Therefore, pavement and stormwater systems must be compatibly designed to mitigate it.

Various pavement technologies are available to address airport sustainability goals. They include technologies such as:

- long life pavement,
- recycled pavement,
- warm mix asphalt,
- cool pavement,
- quiet pavement and
- permeable (porous) pavement (Muench et al. 2010).

All of the technologies can be used in landside applications and most can be used airside. The exceptions include permeable and quiet pavement technologies. Permeable pavements are generally not allowed airside due to traffic and FOD constraints. Quiet pavements were designed to reduce vehicle tire noise, but derive no benefit in an aircraft noise environment. Long life pavement earns its sustainability credibility by being designed to yield an extended service life (Tighe and Covalt 2008). Airport pavements are generally designed to have a service life of 20 years (Applied Research Associates Inc 2011). However, long life pavements are designed to provide a performance period of forty or more years (Applied Research Associates Inc 2011). Enhanced durability reduces operational disruptions and life cycle costs by reducing the frequency of pavement interventions. This in turn, enhances safety and minimizes the environmental footprint associated with more frequent rehabilitations. Recycle content in recycled pavements is limited to subsurface layers of aircraft-traveled pavements, and is generally limited to a specified percentage. Because materials production can have 20 times the impact of construction (Muench et al. 2010), the demand for increasing recycled material content in pavements is growing (Hajj et al. 2008).

Airside pavements are designed with asphalt and concrete. Pavements can be all asphalt, all concrete or composite. Warm Mix Asphalt (WMA) is in use at Boston's Logan Airport. Additionally, reclaimed asphalt pavement (RAP) has been used in the subsurface mix courses to reduce the impacts from extraction and processing of virgin materials like aggregate and asphalt binder. Research has demonstrated the efficacy of pavements that contain RAP (Hajj et al. 2008). However, care must be exercised when RAP is obtained from airside pavements because it may contain coal tar sealer, which is used to inhibit damage from aircraft fuel, but may have a deleterious effect when incorporated into a new mix (Hajj et al. 2008). Use of modified asphalt binders and fuel resistant binders enhance pavement performance. Asphalt shingles and slag can be used in landside pavements but are not currently allowed in primary airside pavements (Touran et al. 2009). Concrete pavements can serve as cool pavements. Concrete mix designs can incorporate supplementary cementitious materials (SCMs) to reduce the amount of cement required. SCMs are waste products, like fly ash and slag, which are generated from certain industrial activities. Reclaimed concrete pavement can also be used in subsurface mix to reduce the impacts from extraction and processing of virgin aggregate.

### ***12.4.2 Construction Sustainability Considerations***

Although most of the sustainability strategies are relegated to the planning and design phases, many activities can enhance sustainability in the construction phase (Ricondo Associates Inc. et al. 2011). Like in other pavement industries, they include reusing and recycling construction waste, using sustainable and local materials, minimizing site disturbances and monitoring construction quality (Ricondo Associates Inc. et al. 2011). Additionally, some airports are implementing “anti-idling campaigns” to reduce emissions from construction vehicles and equipment (Ricondo Associates Inc. et al. 2011). Other strategies involve fuel and chemical spill/leak mitigation. However, unlike in other sectors, noise pollution generated from construction operations is generally a moot point due to mitigation measures in place to reduce aircraft noise. There are other airport-specific construction activities detailing means and methods, logistics, etc., that have been cataloged and can be implemented by an organization so that it can meet its sustainability goals (Ricondo Associates Inc. et al. 2011).

### ***12.4.3 Operations and Maintenance Sustainability Considerations***

The bulk of airport pavement manager effort will occur in this phase since most airports’ infrastructure is in place and the focus has shifted to preserving the pavement network. A pavement is considered to be in the maintenance phase if it is structurally sound and requires maintenance to sustain only the functional, or serviceability, component. If the structural capacity is below a specified level, then the pavement is no longer a candidate for maintenance intervention and requires rehabilitation or reconstruction, as discussed in the next section. Figure 12.3 illustrates these phases.

Major activities in this phase include tracking and evaluating pavement condition to determine maintenance strategies and prioritization, as well as to predict future pavement performance for planning and budgetary purposes, all of which can be facilitated by an APMS (Hajek et al. 2011). An APMS can aid in systematically identifying short term (<5 years) and long term maintenance (>5 years) needs based upon the specified levels of service that *trigger* maintenance and rehabilitation (M&R) interventions in the system for both rigid and flexible pavements (Hajek et al. 2011).

#### **12.4.3.1 Airport Pavement Maintenance**

An airport pavement manager must inspect and maintain certain functional pavement characteristics over the pavement life to ensure safety and serviceability. These include correcting minor pavement distresses, addressing presence of FOD,

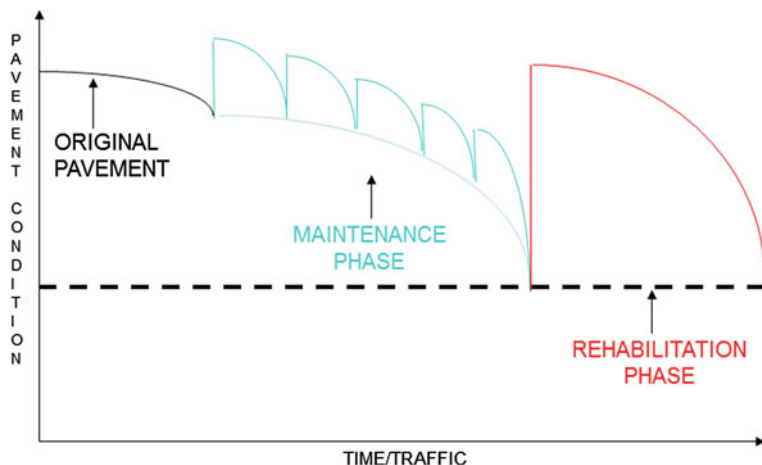

Fig. 12.3 Pavement phases over pavement life

mitigating roughness and maintaining surface friction and other issues, such as maintaining pavement-related NAVAIDs (Hajek et al. 2011). In addition to these engineering issues, project evaluation will increasingly require assessment of all aspects of sustainability. Many pavement treatments may be appropriate solutions to the engineering problem at hand. However, the goal is to determine which treatment provides the greatest net benefit when collectively considering the environmental, operational, societal and economic impact.

It is estimated that 85 % of airfield pavement surfaces are asphalt (Hanson et al. 2009). Common airfield asphalt pavement distresses include rutting, weathering, raveling and cracking (Hajek et al. 2011). Different types of cracking, like longitudinal and transverse cracking, are common distresses in pavements. However, block cracking is a unique type of cracking mainly found in airfield pavements and is attributed to thermal forces (Hanson et al. 2009). Additionally, some unique conditions found at airports can adversely impact asphalt pavement, like jet fuel and jet blast, and can be addressed through treatment selection (Hajek et al. 2011). Table 12.2 lists some common asphalt pavement treatments used on runways and taxiways to maintain serviceability and safety.

Engineering judgment and analyses are required to assess pavement distress and appropriate maintenance action. For example, minor surface cracking may be adequately addressed by crack sealing, but major surface cracking only by an HMA mill and inlay or hot (or cold)-in-place recycle (HIPR/CIPR) action.

Airfield concrete pavement distresses are common to all concrete pavements and include joint seal and spalling, faulting, corner breaks and cracking (Hajek et al. 2011). Specific types of cracking include longitudinal, transverse, diagonal and map cracking. Some of these distresses are caused by ASR. Additionally, some unique conditions found at airports can adversely impact concrete pavement, like deicers and other chemical treatments, and can be addressed through pavement and

**Table 12.2** Common asphalt pavement treatments used on airside pavements

Surface treatment	Chemical treatment	Mechanical treatment
Crack seal/fill	Chemical deicers	Pavement retexturing using shotblasting
Patching (isolated areas)	Asphalt rejuvenator	Pavement retexturing using abrading
Fog seal		Pavement retexturing using a flat headed planing (milling) technique
Microsurfacing		Pavement retexturing using transverse grooving
Ultra-thin bonded wearing course		Diamond grinding
Slurry seal		Watercutting/blasting
Thin (<1.5") HMA overlay		
Thin (<1.5") HMA mill-inlay		
Whitetopping (PCC overlay)		
Hot-in-place recycle (HIPR)		
Cold-in-place recycle (CIPR)		

**Table 12.3** Common concrete pavement treatments used on airside pavements

Surface treatment	Chemical treatment	Mechanical treatment
Crack seal	Chemical deicers	Pavement retexturing using shotblasting
Joint seal		Pavement retexturing using abrading
Patching (isolated areas)		Pavement retexturing using transverse grooving
		Diamond grinding
Partial/full depth repair		Water-cutting/water blasting
Microsurfacing		Load transfer (slab jacking/stabilization, dowel bar retrofits, joint/crack stitching)
Thin (<1.5") HMA mill-inlay		
Thin (<1.5") HMA overlay		
Bonded PCC overlay		

treatment material selection. Table 12.3 lists some common concrete pavement treatments used on runways and taxiways to maintain serviceability and safety.

Pavement treatments serve vital functions with regard to runway serviceability and safety, much the same way as in highway applications. Many of the pavement treatments used to maintain highway pavements can be used in airside applications, as listed in Tables 12.2 and 12.3, to address distresses, roughness and friction. There are some notable exceptions, like chip seals and permeable friction courses, which are not used due to the potential for FOD. Grinding treatments can reduce runway roughness to minimize impact on aircraft fatigue and braking. Pavement surface friction enhances an aircraft’s ability to stop on wet pavements. Tables 12.2 and 12.3 show various mechanical techniques for ensuring friction, such as

abrading and shotblasting. Surface friction deteriorates over time due in part to the effect of aircraft traffic as it mechanically wears aggregate. Rubber deposits on runways are left by landing aircraft and also have a deleterious effect on friction (Gransberg 2008). Transversely-grooved runways enhance macrotexture and microtexture, two components of surface friction. However, increased friction means increased rubber deposit left by aircraft upon landing on runway (Gransberg 2008). It must be periodically removed using one of the available methods: waterblasting, chemical removal, shotblasting or other mechanical means. Ideally, an operator should remove rubber without detriment to existing pavement grooves. Pavement managers must also ensure that snow and ice is removed from runways. Chemical treatments are commonly used to maintain safe runway operations. Some European airports have installed geothermal systems to control pavement temperature.

#### 12.4.3.2 Airport Pavement Preservation

Pavement preservation (also referred to as preventive maintenance) is a proactive approach to pavement maintenance and it can be implemented to address aging pavement asset issues. The goal is to extend pavement service life, whereby reducing the frequency and impacts of pavement interventions by *keeping good pavement good* instead of allowing it to deteriorate to a point where costly maintenance or reconstruction is necessary (Galehouse et al. 2003). Preventive maintenance increases the availability and safety of airport pavements to users and reduces associated operational costs due to delay and disruption (Vreedenburgh 1999). It also provides enhanced fiscal stewardship through the cost effective use of scarce public funds and minimizes the environmental footprint associated with more frequent full scale construction (Galehouse 2010). An APMS can provide the much needed justification for preservation funding requests and demonstrate return on investment (ROI) within an organization's capital improvement and/or asset management plan (Hajek et al. 2011; GHD Inc. 2012).

#### 12.4.3.3 Airport Pavement Operations

Pavement maintenance and management activities can support an airport's environmental management system (EMS). Some airports have implemented EMS (Pittenger 2011). An EMS, like the framework outlined in ISO 14001, is used to capture the measurement and improvement of an airport's impact on the environment to help it achieve and account for its sustainability goals. It involves developing and disseminating an environmental policy that contains objectives and goals, roles and responsibilities, and regulatory requirements and compliance (Muench et al. 2010). It also involves the systematic monitoring of daily preventive and corrective activities and procedures that impact the environment. Sustainable pavement activities can contribute to the progress captured in an EMS.

### ***12.4.4 Reconstruction and Rehabilitation Considerations***

When a pavement has exceeded its structural life, reconstruction or rehabilitation is necessary. The pavement intervention can range from thick asphalt or concrete overlays to full depth reconstruction. Some of the sustainability considerations listed in Table 12.1 are applicable during this phase, such as the decision making processes, pavement technologies and material resources and recycling. All of the sustainable construction activities are applicable.

One sustainability option available during this phase is to use in situ methodologies. Full depth reclamation (FDR) involves recycling and reusing the existing pavement structure as a treated base for the new pavement structure. Rubblizing concrete pavement is another methodology. These sustainability solutions can reduce the economic and environmental impact by reducing material costs and hauling, which can have up to 5 times the impact on the environment as the construction (Muench et al. 2010).

## **12.5 Conclusion**

Demand for airport pavement sustainability strategies, practices and tools will continue to grow as airport owners and operators grapple with “how to do more with less”, meet stakeholder and customer needs and comply with policy and regulations. Effort will be invested in implementing methods, such as life cycle cost analysis and life cycle assessment, as well as improving data availability and quality for analyses, for the purpose of effectively quantifying the net benefit, or trade-offs, between the sustainability aspects of a given pavement project (Muench et al. 2010).

Asset management plans will likely become an essential component of airport infrastructure management strategies over the next decade for the purpose of strategically managing asset investment, performance and liabilities (GHD Inc. 2012). Airport pavement management systems, which support AM, will evolve from an implementation phase to an improvement phase (Hajek et al. 2011). Improved ways of assessing functional and structural condition of pavements will assist pavement managers in determining optimum timing for pavement intervention, enhancing safety and cost effectiveness.

Pavement technologies, materials, means and methods will also continue to evolve. Innovative pavement technologies will flourish in an effort to make pavements more durable, cost effective and ecofriendly. There will be wider use of recycled materials in airfield pavements, such as RAP and reclaimed concrete pavement (Hajj et al. 2008). The list of pavement treatments will continue to expand. Pavement preservation will continue to thrive and will extend pavement service lives (Galehouse et al. 2003). In situ methodologies to rehabilitate and reconstruct airfield pavements will also continue to increase.



- Greater Toronto Airports Authority. (2010). *Outside, Inside, Upside. A Three-Dimensional Look at Corporate Social Responsibility* (p 9). Greater Toronto Airports Authority 2007. Accessed March 2, 2010 from <http://gtaa.com/local/files/en/Community/Publications/CorporateSocialResponsibilityReport2008-07-23.pdf>
- Gransberg, D. D., Scheepbouwer, E. (2010). *Infrastructure Asset Life Cycle Cost Analysis Issues*. AACE, TRK.01, May 2010.
- GHD Inc. (2012). *Asset and Infrastructure Management for Airports*, ACRP Report 69. Transportation Research Board, National Academies, Washington, D.C.
- Gransberg, D. D. (2008). *Impact of airport rubber removal techniques on runways*. ACRP Synthesis 11, Washington, D.C: Transportation Research Board, National Academies.
- Hajek, J., Hall, J. W., Hein, D. K. (2011). *Common airport pavement maintenance practices—a synthesis of airport practice*. ACRP Synthesis 22, Transportation Research Board, National Academies, Washington, D.C.
- Hajj, E. Y., Sebaaly, P. E., Kandiah, P. (2008). Use of Reclaimed Asphalt Pavements (RAP) in Airfield HMA Pavements, AATP Report 05–06, Airfield Asphalt Pavement Technology Program, Auburn, Alabama.
- Hanson, D. I., King, G., Buncher, M., Duval, J., Blankenship, P., Anderson, M. (2009). Techniques for prevention and remediation of non-load related distresses on hma airport pavements, AATP Report 05–07, Airfield Asphalt Pavement Technology Program, Auburn, Alabama.
- Loizos, A., Charonitis, G., Katsoulas, P. (2006). Rating the aircraft load and reporting the bearing capacity of rigid airport pavements, *Road Materials and Pavement Design* (Vol. 7—No. 3/2006, pp. 349–367).
- Muench, S. T., Anderson, J. L., Hatfield, J. P., Koester, J. R., Söderlund, M. et al. (2010). In J. L. Anderson & S. T. Muench (Eds.), *Greenroads rating system v1.0*. Seattle, WA: University of Washington
- Mukherjee, A., Cass, D. (2012). A project based framework for monitoring and controlling greenhouse gas emissions. *Transportation Research Record, Journal of the Transportation Research Board*, Washington DC.
- Nowak, G. (2011). *Airfield pavement design and construction*, Presentation to CAPTG Workshop, Montreal.
- Ozbay, K., Jawad, D., Parker, N. A., Hussain, S. (2004). Life cycle cost analysis: state of the practice versus state of the art. *Transportation Research Record: Journal of the Transportation Research Board* (No. 1864, pp. 62–70). Washington, D.C: TRB, National Research Council.
- Peshkin, D. G., Hoerner, T. E., Zimmerman, K. A. (2004). *National Cooperative Highway Research Program, NCHRP, Report 523 Optimal Timing of Pavement Preventive Maintenance Treatment Applications*, Transportation Research Board, TRB, National Research Council, Washington, D.C.
- Peshkin, D. G., Bruinsma, J. E, Wade, M., Delatte, N. (2006). Accelerated practices for airfield concrete pavement construction, Innovative Pavement Research Foundation, Airport Concrete Pavement Technology Program. Skokie, Illinois.
- Pittenger, D. M. (2011) Evaluate airport pavement maintenance/preservation treatment sustainability using life-cycle cost, raw material consumption and ‘greenroads’ standards. *Transportation Research Record, Journal of the Transportation Research Board* (Issue 2206, pp 61–68), National Academies, Washington D.C.
- Rangan Gopalakrishnan, K., & Thompson, M. R. (2006). Severity effects of dual-tandem and dual-tridem repeated heavier aircraft gear loading on pavement rutting performance. *International Journal of Pavement Engineering*, 7(3), 179–190.
- Reigle, J. A., Zaniewski, J. P. (2002). *Risk-Based Life-Cycle Cost Analysis for Project-Level Pavement Management*. Transportation Research Record 1816, Paper No. 02-2579.
- Shafer, G. R. et al. (2012). *Guidebook for Developing General Aviation Airport Business Plans*. ACRP Report 77. Washington, D.C: Transportation Research Board, National Academies.
- Sustainable Aviation Guidance Alliance. (2010). Introduction to Sustainability. Retrieved April 18, 2010 from <http://www.airportsustainability.org/>



- Sinha, K. C., Labi, S. (2007) *Transportation Decision Making: Principles of Project Evaluation and Programming* (pp. 199–211). Hoboken, New Jersey: John Wiley and Sons, Inc.
- Tighe, S., & Covalt, M. (2008). *Implementation of an airport pavement management system, transportation research circular E-C127*. Washington, D.C: Transportation Research Board.
- Touran, A., Gransberg, D. D., Molenaar, K. R., Bakshi, P., Ghavamifar, K. (2009). *A Guidebook for the selecting airport capital project delivery methods* (p. 101), ACRP Report 21, Transportation Research Board, National Academies, Washington, D.C.
- U.S. Department of Transportation Federal Highway Administration Office of Asset Management (FHWA). (2002). *Life Cycle Cost Analysis Primer*. Washington, D.C.
- USDOT. (2001). Report to the U.S. congress on environmental review of airport improvement projects, Retrieved March 3, 2013 from [http://www.faa.gov/airports/resources/publications/reports/environmental/media/enviro\\_review\\_airport\\_improvement\\_projects\\_report.pdf](http://www.faa.gov/airports/resources/publications/reports/environmental/media/enviro_review_airport_improvement_projects_report.pdf)
- Vreedenburgh, M. (1999). *Airport operational efficiency*. ICAO Airport Privatization Seminar for the NAM/CAR/SAM Regions. Guatemala City. Retrieved December 13–16, 1999.
- Wade, M., Wolters, A., Peshkin, D., Broten, M (2001). Prioritization of airfield pavement rehabilitation projects. *Advancing Airfield Pavments*, American Society of Civil Engineers (ASCE), ISBN (print): 978-0-7844-0579-6, 27th International Air Transportation Conference, Chicago, Illinois, United States.
- Zietsman, J., Ramani, T., Potter, J., Reeder, V., DeFlorio, J. (2011). *NCHRP Report 708: A Guidebook for Sustainability Performance Measurement for Transportation Agencies*, National Cooperative Highway Research Program, Transportation Research Board.

# Chapter 13

## Sustainable Pavement Management

Gerardo Flintsch and James Bryce

**Abstract** Sustainable pavement management as a business practice is about facilitating pavement investment trade-offs considering the triple bottom line of sustainability during the design, construction, maintenance, and rehabilitation of pavements. This chapter discusses the basic principles of pavement management and the changes necessary to help pavement manager make more sustainable decisions. It discusses the various levels of pavement management decisions, the importance of pavement management as a key asset management business process, and the data needed to support the various levels of analysis. A more sustainable decision-making process requires tools for analyzing the economic, environmental, and social impacts, as well as for comparing the pavement investment trade-offs. The chapter reviews some of these tools, provides guidelines for incorporating sustainability into the various levels pavement management decision making, and recommendations for making pavement management systems sustainable within an organization.

### 13.1 Introduction

Sustainable pavement management is an emerging field within infrastructure management that is concerned with maintaining acceptable condition of pavements while also considering the tradeoff between cost, environmental impacts and social impacts of pavement investments. Generally the tradeoff between economic, environmental and social factors requires that the agency in charge of managing pavements maintains an accurate database that includes the pavement condition and

---

G. Flintsch (✉) · J. Bryce  
Center for Sustainable Transportation Infrastructure, Virginia Tech Transportation Institute,  
3500 Transportation Research Plaza, Blacksburg, VA 24061, USA  
e-mail: flintsch@vt.edu

J. Bryce  
e-mail: jmbp54@vt.edu

models to predict the resulting impacts of pavement management decisions on each of the factors. In many cases, assumptions must be made about the environmental and social impacts, and therefore pavement management decisions must reflect the level of certainty that the agency has in the assumptions. Consequently, a high level of uncertainty in many cases tends to lead the agency to only consider economic considerations within pavement management, and environmental mitigation techniques are employed after the selection of the intervention or design of the pavement is complete.

## 13.2 Sustainable Infrastructure

Infrastructure can be seen as the foundation that connects the natural environment to the economy and social systems by facilitating the movement of goods, services, and people. The consequence of this connection is that the quality of infrastructure has a direct impact on the economy, the quality of the natural environment and the quality and equity of societies. This is what is generally known as the triple bottom line of sustainability (balancing economic, environmental and societal impacts). In light of this, sustainable infrastructure can be viewed as infrastructure that maximizes the quality of life of a society and its economic benefits while also minimizing detrimental impacts on the natural environment.

The American Society of Civil Engineers (ASCE) has defined sustainability as; “A set of environmental, economic and social conditions in which all of society has the capacity and opportunity to maintain and improve its quality of life indefinitely without degrading the quantity, quality or the availability of natural, economic and social resources” (ASCE 2012). Thus, to promote a truly sustainable transportation network, decisions made about the treatment and expansion of the network should take into account environmental and social factors, along with economic and technical considerations. In order to implement sustainability into civil infrastructure, ASCE has applied the definition of sustainability to sustainable development as, “the process of converting natural resources into products and services that are more profitable, productive, and useful, while maintaining or enhancing the quantity, quality, availability and productivity of the remaining natural resource base and the ecological systems on which they depend”(ASCE 2012).

## 13.3 Pavement Management

Sustainable pavement management is the application of sustainability considerations to traditional pavement management practices. Thus, an understanding of pavement management principles is essential to understanding how to management pavement assets more sustainably. It is well known that maintaining pavements by merely rehabilitating pavements that are in the worst condition is not an

economically optimal strategy (Hudson et al. 1997). Instead, a balance must be made between rehabilitating pavements in poor condition and preserving pavements in good condition, often in the face of limited funding. Finding the optimal maintenance and rehabilitation (M&R) strategy given several pavement assets in varying conditions and several M&R options is the foundation of pavement management. More formally, pavement management is a systematic, objective, and consistent procedure to assess the current condition and predict future condition of pavements given certain constraints (e.g. budgetary) and M&R options (Shahin 2005). This follows the terminology provided by Hudson et al. (1997), which defined management as, “the coordination and judicious use of means and tools, such as funding and economic analysis to optimize output or accomplish a goal of infrastructure operation”.

### ***13.3.1 Level of Decisions Supported***

Pavement management includes analysis at multiple levels, generally divided into the strategic level, network level and project level (Flintsch and Chen 2004). Figure 13.1 illustrates the relationship between these decision levels, extent of the network involved, and detail of data required for supporting these decisions. The strategic level is where broad goals and objectives are set for the various transportation assets, including the pavement network, and budgets are determined and allocated to different goals and modes. This may include such broad statements as, ‘*Maintain the pavement in good condition*’, or ‘*Increase safety for the travelling public*’. The next level of pavement management in terms of increasing detail is the network level. The network level is where the pavement budget is defined, and candidate projects are selected based on a needs analysis. The data used in network level analysis is considerably less detailed than the data required for a pavement design, and is generally represented by broad indicators (e.g. the Pavement Condition Index as defined by ASTM International (ASTM International 2011)). Following the project selection step, each project selected at the network level is investigated at a higher level of detail, also known as the project level. Project level data is detailed enough to use for specific pavement designs.

## **13.4 Pavement Management as a Key Asset Management Business Process**

Pavement management falls under the umbrella of asset management, where the pavements are viewed as assets that have inherent values, expected life’s and risks. Asset management is a process by which an agency attempts to make optimal decisions about resource allocation and future planning based on a number of

**Fig. 13.1** Levels of decisions in pavement management

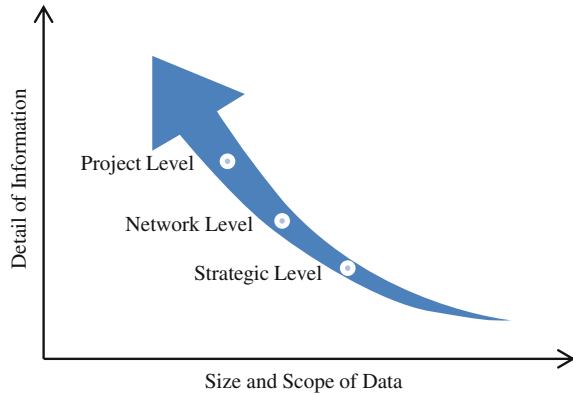

engineering, economic and social issues. The American Association of State Highway Transportation Officials (AASHTO) defines asset management as the following (Cambridge Systematics Inc. 2002);

a strategic and systematic process of operating, maintaining, upgrading, and expanding physical assets effectively throughout their lifecycle, focusing on business and engineering practices for resource allocation and utilization, with the objective of better decision making based upon quality information and well defined objectives.

It is widely recognized that asset management requires cooperation throughout the entire agency. Thus, asset management should involve processes by which an agency involves its employees in improving organizational effectiveness in the accomplishment of agency mission and goals. This requires the establishment of strategic planning and defined goals and objectives for each level in the agency. Successful asset management should include activities and processes that ensure that goals are consistently being met in an effective and efficient manner. AASHTO has developed a guide for asset management implementation in order to guide agencies on best practices for asset management implementation. This guide, *AASHTO Transportation Asset Management Guide: A Focus on Implementation* has outlined 14 steps that need to be completed for transportation asset management implementation (AASHTO 2011).

### ***13.4.1 Setting Agency Goals and Monitoring Performance***

Implementing sustainable pavement management as an asset management business process requires that an agency sets goals and objectives that include sustainability considerations, and develop measures to monitor the performance and achievement towards the goals. Agency goals, objectives and performance measures are all key pieces to pavement management that occur at the strategic level. Strategic goals are statements that reflect the expectations and requirements of the legislative and

executive offices in charge of the highway agency. Strategic goals are generally very broad, and may change as leaders of the executive and legislative branches of state or local government change office. In order to meet the goals, a set of strategic objectives are developed. Strategic objectives are targeted performance (e.g., pavement condition) levels that act as a way to link the strategic plan and performance goals. In order to connect the agencies strategic objectives with the current condition of the network, a number of performance measures are developed. Performance measurement is a process for collecting and reporting information regarding the performance of an asset or organization. Performance measurement is how organizations, public and private, assess the quality of their activities and services. Data collection and interpretation, along with robust decision support tools, are important pieces to monitoring performance and aligning an agencies decisions with their goals.

### ***13.4.2 Data Collection***

One critical requirement for successful asset management, including a meaningful performance measurement program, is a successful data collection program. Pantelias et al. (2009) discuss the importance of designing the asset management data collection program specifically to meet the agency goals in order to minimize the amount of unnecessary data collected. Data required for pavement management may vary based on the agency goals and performance measures, but includes an accurate inventory of the pavements along with condition, age and construction history data.

The detail of data collected is a function of the level of analysis that will be performed with the data (see Fig. 13.1). Data for a typical pavement management program is collected at the network level, which implies that the level of detail of the collected data is less than the level of detail that would be used for design. As discussed in Pantelias et al. (2009), decisions that are made at a higher level (i.e. network or strategic level) require data that are aggregated over a much more broad range than lower level decisions (i.e. project level decisions). This typically results in data that is reported in condition values, which are single values that represent an aggregation of all pavement distresses, which are averaged over similarly constructed pavement segments.

## **13.5 Decision Support Tools**

Sustainable pavement management often requires the use of numerous decision support tools in order to provide the managing agency with methods to evaluate the various management alternatives. An example of one such decision support tool is the use of life cycle cost analysis (LCCA) as a method to evaluate the long term

economic costs of a given management alternative. The purpose of decision support tools is to provide a platform for comparison of many alternatives, and several tools are discussed in the following sections.

### ***13.5.1 Economic Analysis***

Determining the economic impacts of pavement management policies and interventions is an important step towards guaranteeing optimal life cycle performance of pavements. Agencies in charge of managing pavements are often faced with budget constraints, thus selected treatments must demonstrate their technical and cost effectiveness in addressing short-term and long-term structural and functional deficiencies. Criteria for evaluation may be grouped in costs and benefits (Hudson et al. 1997). Costs include agency or direct costs (e.g., initial capital, maintenance, salvage return, financing), and non-agency or indirect costs (e.g., user costs, environmental impact, disruption). Benefits are typically determined in terms of increased functionality of the pavements, such as increased pavement condition and capacity. Further benefits such as income generation or increased mobility could arise from implementing a particular project, however these benefits are typically not addressed in modern cost benefit analysis for pavements.

LCCA is an economic analysis method for comparing long term investment options, generally with the purpose of comparing the overall long-term costs of several alternatives. The use of LCCA in pavement design and management is discussed thoroughly in a technical brief released by FHWA (1998). The first step in conducting an LCCA is to develop several management alternatives, along with the analysis time frame, and activity timing and condition triggers for specific maintenance actions. Next, agency and user costs should be developed for each of the activities over the analysis time frame. User costs may also include the marginal increase in fuel consumption that results from an increase in pavement roughness between the specific activities. The next step in an LCCA is to develop expenditure streams, which include the discounted costs over time, and compute the net present value for each alternative.

LCCA can be categorized as either deterministic or probabilistic. Deterministic LCCA is a type of analysis that uses fixed values in the analysis, whereas a probabilistic approach uses distributions to represent the variability of the various input and output parameters used in the analysis. For example, a deterministic approach may define the cost for a particular action as  $x$ , where the probabilistic approach would define the cost as a distribution with a mean value of  $x$  and a given standard deviation. This concept is illustrated in Fig. 13.2.

A benefit to the probabilistic approach over the deterministic approach is that risk can be evaluated from the outputs of the probabilistic LCCA. This is because the solution reached from the probabilistic approach is a distribution representing the possible outcomes along with the probability of each outcome. Several tools are available for a probabilistic LCCA, such as the FHWA program RealCost (FHWA

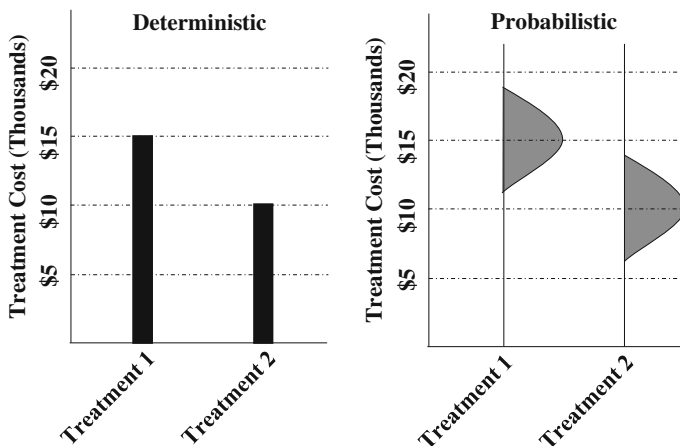

Fig. 13.2 Deterministic and probabilistic LCCA

2013). Chen and Flintsch (2012) proposed a fuzzy logic based model to enhance the probabilistic LCCA approach by providing a method to better interpret some of the inherently ambiguous inputs.

Another economic tool available for evaluating pavement management decisions is cost benefit analysis (CBA). The approach to CBA is to first evaluate the costs of the pavement management alternative, then the benefits of each alternative are calculated, and finally each alternative is compared on the basis of both its costs and benefits (e.g. comparing the costs divided by the benefits). Hudson et al. (1997) describe this process in more detail. The CBA approach differs from LCCA because costs are offset by benefits, meaning higher costs may be compensated for by higher benefits. Similar to LCCA, CBA can be conducted either deterministically by using expected costs and benefits, or probabilistically as described in Butt et al. (1994). Lamptey et al. (2005) discuss several other economic tools for use in pavement management,

### 13.5.2 Environmental Analysis Tools

The tool that is generally understood to be the most appropriate for studying the environmental impacts of the pavement system is the lifecycle assessment (LCA). The purpose of a pavement LCA is to quantify the total environmental impact of the pavement throughout the pavements life, which is generally divided into the following five phases (Santero et al. 2011); (1) raw materials and production, (2) construction, (3) use, (4) Maintenance and (5) end of life.

LCAs are generally categorized as either process based models, economic input-output models or hybrid (a combination of process based and input-output models).



Process based models are based on the resource use and environmental impacts from the main processes of the system under evaluation (Suh et al. 2004). Generally, the process based LCA can be represented as flow diagrams or matrices describing each process interactions. Economic input-output models are top down hierarchical models which use total factor multipliers based on the national economy to determine embodied effects per unit of production (Lenzen 2008). Different parameters within the process are weighted based on their contribution, and then broken into more detailed levels until the entire process is defined at an adequate level of detail. Input–output LCA models account for interdependencies between sectors and processes using monetary transactions between the sectors on a national or global economic scale. A more detailed discussion of the LCA types, along with a comparison of strengths and weaknesses can be found in (Santero et al. 2011).

The most common method for conducting an LCA is a process-based method that is defined by the International Standards Organization (ISO). The ISO outlines a four step approach in their standard ISO 14040 and ISO 14044, Standards for a Process-Based LCA Approach (International Organization for Standardization 2006). The steps are as follows:

1. Goal and scope. Define the reasons for carrying out the LCA, the intended audience, geographic and temporal considerations, system functions and boundaries, impact assessment, and interpretation methods.
2. Inventory assessment. Quantify life-cycle energy use, emissions, and land and water use each life-cycle stage.
3. Impact assessment. Estimate the impacts of inventory results.
4. Interpretation. Investigate the contribution of each life-cycle stage and technology use throughout the life cycle and include data quality, sensitivity, and uncertainty analyses.

Huang et al. (2009) describe the process given in ISO 14040 in more general terms as (1) defining the scope, (2) performing the LCI to gather all relevant environmental burdens (this is where the majority of the work resides), (3) perform a lifecycle impact assessment (LCIA) where the results are presented in such a manner that supports comparison, interpretation of the results or further analysis. Santero et al. (2011) notes an important distinction between life-cycle inventories (LCI's) as the part of an LCA in which the resource use and pollutant releases are quantified and the full LCA which includes an impact analysis and interpretation of the results.

Santero et al. (2011) performed a critical assessment of the current state of pavement LCA's by extensively reviewing available literature on the topic. The researchers identified four attributes of the methodology of the LCA that are essential for comparing the studies, (1) Functional Unit Comparability, (2) System Boundary Comparability, (3) Data Quality and Uncertainty and (4) Environmental Metrics. Functional unit comparability becomes an issue when trying to compare results from studies that evaluate different pavements that facilitate different traffic types across different climates or environmental regions. Essentially, many of the results of LCAs found in literature cannot be directly compared due to the differing

functional units (Santero et al. 2011). The researchers note the omission of the use phase from the majority of pavement LCA's as possibly the most significant shortfall of modern studies. Furthermore, it was noted that a majority of the studies that included maintenance in the system boundaries simplified the maintenance practices to a series of repeated impacts, and did not include preservation practices such as diamond grinding or crack sealing.

The LCA of the raw materials, material production and construction phases of the lifecycle have been the focus of extensive research. For example, Pavement Life Cycle Assessment Tool for Environmental and Economic Effects (PaLATE) is a spreadsheet based tool that was developed to account for both economic and environmental factors related to the construction processes of a pavement (Horvath 2003). Park et al. (2003) evaluated the environmental loads due to the processes throughout the lifecycle of a highway, defined in four stages as: (1) manufacturing of materials, (2) construction, (3) maintenance and (4) end of life (demolition/recycling), but notably the use phase is excluded from the definition of the pavement lifecycle. The researchers focused on energy consumption, then used appropriate factors to translate the energy consumption into equivalent emissions and estimate pollutant discharge into water.

Huang et al. (2009) evaluated modern LCA data and methods pertaining to pavements, then applied the techniques to an airport asphalt paving project. The research identified major shortcomings with many modern LCA methods, such as their inapplicability to pavements, and proposed an updated LCA model based on the processes contained within asphalt pavement construction. The researchers identified the quality of the gathered data as an important parameter that should be continuously improved as new data arises. The results of an example LCA using the developed model proved insightful for decision makers and understanding the critical factors that contribute to adverse environmental impacts (Huang et al. 2009). Furthermore, the detailed unit processes involved in the construction of an asphalt pavement were represented in the paper by Huang et al. (2009).

Some other examples of pavement LCAs are described in Patrick and Arampamoorthy (2010), Weiland and Muench (2010), Wang et al. (2012) and Zhang et al. (2010). The work by Patrick and Arampamoorthy concluded that potentially significant savings in energy consumption and emissions can be achieved through waste minimization (Patrick and Arampamoorthy 2010). Weiland and Muench (2010) compared three different options of replacing a Portland Cement Concrete (PCC) pavement, including two HMA options and one PCC option, and demonstrated the use of several tools for conducting LCA's, such as the US Environmental Protection Agency's (EPA) NONROAD model for construction equipment and the EPA's Tool for the Reduction and Assessment of Chemical and Other Environmental Impacts (TRACI). Wang et al. (2012) and Zhang et al. (2010) both presented methodologies for including limited factors of the pavement use phase into the LCA by linking the pavement condition to vehicle rolling resistance.

Much of the research pertaining to the use phase of the pavement has focused on quantifying the effect of rolling resistance on emissions and energy consumption from vehicles travelling on the pavement. Several research projects have quantified

the impact of pavement properties on rolling resistance, and some research has shown that in all driving conditions, an overall average of 25 % of fuel consumption is expended on rolling resistance leaving 75 % to overcome air drag and inertia (Izevbekhai 2012). Thus, if the rolling resistance of a pavement were reduced, the vehicle fuel consumption along that pavement would be reduced. Furthermore, a 10 % reduction in rolling resistance can lead to between a 1 and 2 % reduction in fuel consumption, which also leads to a reduction of greenhouse gas emissions (Evans et al. 2009), (Transportation Research Board: Committee for the National Tire Efficiency Study 2006). The tire-pavement interaction is the main factor in rolling resistance, and is impacted by several variables such as: macro-texture, pavement stiffness, roughness, rutting and the transversal slope of the pavement. Relatively good relationships have been developed to determine the impact of roughness (IRI) and macro-texture (MPD) on a vehicles rolling resistance, whereas relationships between rolling resistance and other pavement surface factors have not been adequately developed at this time.

Two commonly used models relating pavement properties to rolling resistance and fuel consumption have been developed in recent years. One model was developed by Chatti and Zaabarby calibrating the HDM 4 models for vehicle operating costs (Chatti and Zaabar 2012). The fuel consumption model was calibrated over several pavements in the state of Michigan using six different vehicles: a medium car, sport utility vehicle, van, light truck, and an articulated truck. The details of the model can be found in the NCHRP report 720 (Chatti and Zaabar 2012), along with a Microsoft Excel™ tool developed as part of the NCHRP project that can be used to estimate vehicle operating costs (as well as vehicle fuel consumption) given several conditions.

A second model was developed as part of an international collaboration, Models for rolling resistance In Road Infrastructure Asset Management systems (MIRIAM). Some outcomes and models developed as a part of MIRIAM are described in detail in Hammarstrom et al. (2011) and Wang et al. (2012). The model was developed based on empirical results from coast down measurements in Sweden, and includes impacts of: pavement roughness, macrotecture, temperature, speed, horizontal curvature and the road grade. The model was developed for three vehicle types, a car, a heavy truck and a heavy truck with a trailer.

### ***13.5.3 Equity and Other Social Considerations***

One fundamental objective of any transportation system is to provide a safe and equitable connection between society and the services it needs while also minimizing any impacts that adversely impact any portion of society. Thus, it is clear that equity must be evaluated as an integral part of sustainability. Muench et al. (2010) describe equity as, “political or mandated processes for ensuring environmental justice, cultural and aesthetic considerations”. The California Energy Commission has described environmental justice as a way of ensuring all people,

regardless of their socio-economic status, race or any other factors, enjoy equally high levels of environmental quality (California Energy Commission 2014). Whereas environmental impacts of infrastructure have been well documented, the social and equitable factors resulting from investment in infrastructure management are less developed. Some research has shown the extent of a society's well-being has been directly correlated to the extent of that society's infrastructure (Chamorro and Tighe 2009). The interconnected systems of highways, bridges, pipelines and dams have made the changes in social behaviors possible by providing mobility, safe drinking water, waste management, and stable structures. The presence of an extensive road network allows people in rural areas to have access to health care markets, and financial resources that are typically more prevalent in urban areas, and clean drinking water is a basic need for the health of all people. This concept is discussed further in Jeon et al. (2006) on the basis of evaluating transportation sustainability within four transportation agencies. One finding in Jeon et al. (2006) was that no transportation agency measured the impact of equity by evaluating the relative accessibility of the population to basic services.

Several aspects directly related to equity in pavement management are addressed in sustainable rating tools for highways such as Greenroads (Muench et al. 2010). Some examples of social related considerations on which pavement management practices can have a direct impact include metrics to improve human health and safety, and improve access and mobility. Some important considerations in equity also coincide with environmental concerns, such as the reduction in air pollution, minimizing the use of non-renewable resources (minimize impact on future generations), and minimizing water use during construction.

#### ***13.5.4 Multi-attribute Decision Making***

The field of pavement management, or more broadly infrastructure management, consists primarily of investment tradeoffs considering multiple competing objectives and multiple stakeholders. Therefore, an important tool to consider for sustainable pavement management is multi-attribute decision making. Important aspects in multi-attribute decision problems are multiple objectives (i.e. multiple criteria and desired levels of attainment for each criterion), constraints for the criteria, and preference functions or weighting values used to compare the criteria. Solutions for multi-criteria problems are given by a set of non-dominated solutions (as opposed to a single optimal solution), and thus some judgment or preference function must be evaluated to select the preferred solution from amongst the non-dominated set.

Several methods exist for solving multi-attribute problems. For example, Wu and Flintsch (2009) present a method for replacing traditional deterministic constraints with stochastic constraints before developing the set of non-dominated solutions. Giustozzi et al. (2012) proposed a method of rescaling each criterion between zero and one, weighting each criterion in terms of preference, and then

summing the product of each rescaled criteria and criteria weight to determine the best alternative. Some other methods for solving multi-attribute decision problems are discussed in more depth below.

Galenko et al. (2013) presented the application of utility theory in highway asset management strategy development, and proposed that optimizing resource allocation in asset management should be based on the maximization of the overall utility attributed to the assets. Utility theory is a method for solving multi-attribute problems in which a decision maker's values are quantified over a range of feasible outcomes, then the values are combined with the corresponding probabilities of each outcome to form a set of utility values. The motivating factor behind utility theory is that if an appropriate utility is assigned to each possible outcome, and the expected utility of each alternative is calculated, the best alternative is the one that maximizes the overall utility (Keeney and Raiffa 1993). The strength of utility theory is that the relative strength of preference between possible outcomes for each variable is used to determine the best alternative from the set of possible alternatives. In other words, it is not assumed that increasing a variable four times the original amount has double the value of increasing the original amount by two times.

Li and Sinha (2004) presented a method for using utility theory in transportation asset management decision making. The utility curves for several individuals were assessed over a number of parameters through questionnaires and interviewing techniques. The utility functions were then aggregated using an ordinary least squares regression technique (OLS) technique. Another application of utility theory in transportation decision making was presented by Zietsman et al. (2006). In this case, the utility curves were assumed to have particular shapes and curvatures at certain points based on typical human preferences.

One important aspect of multi-criteria problems is the aggregation of preferences among many decision makers. The importance of comparing the preferences between the many decision makers is because it is possible that different solutions are seen as optimal to different decision makers. One method for comparing preferences is through preference rank aggregation. The use of ranking methods in transportation decision making has been demonstrated when evaluating the alignment of a proposed new highway. Stich et al. (2011) developed a number of proposed alignment alternatives using GIS tools, and then utilized a public informational meeting to have the voters rank the projects given all of the relevant information (i.e. wetland impact, noise and air pollution, etc.) about each alternative. In this case, the highway agency acts as the final decision maker, and the rankings of the voters are used in the final ranking of the projects. One policy related benefit that the research cited about gathering the stakeholders' preferences was the possibility of streamlining project delivery times by addressing concerns of the public before they arise, instead of retroactively trying to mitigate the problems and concerns.

Lahdelma et al. (2000) describes the use of ranking alternatives among the many stakeholders as an important key to environmental decision making. The authors discuss the importance of gathering the ranking among the stakeholders given that

environmental planning is of strong interest to many stakeholders beyond just the decision making organization. Furthermore, the authors point to the importance of clearly defining the alternatives and criteria, as well as how each criterion is measured so that no ambiguity exists among the stakeholders. Finally, it is discussed in the paper that the rankings of the many alternatives among the many stakeholders can be used to develop new alternatives that more closely reflect the values of the many stakeholders (Lahdelma et al. 2000).

Another example of ranking is by the use of the analytical hierarchy process (AHP). Smith and Tighe (2006) describe using AHP as a tool for assessing user preferences of maintenance and rehabilitation decision making in transportation asset management. A large subset of road users were identified and surveyed to determine their preferences for many different criteria related to road maintenance and rehabilitation. The preferences were then aggregated by using a simple averaging technique, and the AHP technique was used to evaluate the criterion that was considered most important by user groups, and how the user groups would weight various alternatives.

## **13.6 Incorporating Sustainability into the Pavement Management Decision Making Process**

Beyond defining pavement sustainability and sustainable performance measures is the critical step of implementing sustainability into the pavement management decision making process. This includes incorporating sustainability as a fundamental business practice within the agency where considerations about project selection, treatment type selection, lifecycle management, and the tradeoff between the triple bottom line (economic, environmental and social impacts) are addressed in the initial decision processes. Sustainability can be included at all three levels of the pavement management process discussed in Sect. 13.3.1, and each will be discussed in more detail in the following sections.

### ***13.6.1 Project Level***

Decisions about pavement design, construction practices and scheduling, material acquisition, and congestion management plans are just a few examples where sustainability can be implemented at the project level. For example, Diefenderfer et al. (2012) discuss an in situ pavement recycling process used on part of a Virginia interstate that attempted to minimize the use of virgin construction materials, minimize construction costs and minimize the impact on the travelling public through a use of innovative management practices. In the case discussed by Diefenderfer et al. (2012), the lowest lifecycle cost option that was considered also had

the most environmental benefit, and the least adverse social impact (as measured by travel time interruption, depletion of virgin materials and reduction of construction waste).

Another aspect that should be considered at the project level is the impact of the maintenance on the rolling resistance and vehicle operating costs from a lifecycle perspective. For example, the minimal maintenance cost alternative for rehabilitating a pavement may be to apply light maintenance for a defined number of intervals. However, a more extensive rehabilitation may reduce the rate of deterioration of the condition and the rate of increase in roughness for a road, which in turn leads to a reduction in the overall vehicle operating costs, fuel consumption and vehicle emissions for the pavement.

Pavement type selection and design are fundamental concerns during project level pavement management. Pavement type selection refers to choosing the most appropriate paving material (i.e. Portland cement concrete or asphalt concrete) to be used during construction. Typically, this choice comes down to the result of a lifecycle cost analysis, the availability of local construction materials, and the familiarity of local contractors with constructing using the materials (Hallin et al. 2011). However, many more factors can be included, and their tradeoffs considered, in order to make the pavement type selection process more sustainable. For example, given the models that relate vehicle fuel consumption to pavement properties, a lifecycle assessment can be conducted for each paving material in consideration. It is clear that values for the surface texture and pavement roughness will change over time at different rates for different material types, thus resulting in different fuel consumption, emissions profiles and total vehicle operating costs for each pavement over a defined time frame (Chatti and Zaabar 2012). Secondly, maintenance practices and the availability of local materials (virgin or recycled) differ for each pavement type, which will impact the results of any assessment of sustainability during pavement type selection (Patrick and Arampamoorthy 2010). Finally, the impact of the pavement surface characteristics on effects such as carbonation, pavement lighting requirements and the urban heat island effect (considering pavement albedo) should also be considered during pavement type selection (Santero et al. 2011).

### ***13.6.2 Network Level***

Sustainable pavement management practices at the network level includes designing maintenance strategies and selecting projects while considering impacts related to the triple bottom line of sustainability. This may include modifying the objectives of a network level analysis so that a multi-criteria approach is considered during the unconstrained needs analysis and optimization. Generally, the resulting multi-objective decision problem arising from the network level pavement management process is converted to a single objective problem by treating some of the objectives as the constraints (Wu and Flintsch 2009). In this way, an agency seeks



to maximize or minimize one particular objective (e.g. minimizing the cost divided by the performance of the pavement condition) subject to constraints that arise from the original objectives (e.g. budgetary constraints or constraints defining a minimum allowable pavement condition).

A shortcoming with the single criterion approach is that when objectives are reformulated as constraints, the resulting analysis becomes non-compensatory (Goodwin and Wright 1998). In other words, undesirable values in the newly formulated constraints are no longer compensated for by highly desirable values in the objective values. Consequently, there is no longer a guarantee that the selected value is non-dominated, and a more optimal value may exist depending on the extent to which the constraints are relaxed. A non-dominated solution is a solution in which it is not possible to better the outcome of one variable without making worse the values of the remaining variables. Secondly, the non-compensatory analysis tends to bias the results to the parameter that is chosen as the objective function, thus rendering other objectives as lower level considerations.

Giustozzi et al. (2012) presented a multi-criteria approach for evaluating preventive maintenance activities that included costs, performance and environmental impact measures during the analysis. Several maintenance strategies were evaluated based on the measures, and a method for comparing all strategies by rescaling each measure was developed. The first step in the analysis was to define the strategies, as well as the associated lifecycle cost for each strategy. Then the performance was calculated as the area beneath the curve defining the condition as a function of time. Finally, the energy consumption and emissions related to each strategy were calculated for the materials and construction phase of the LCA. The measures were all scaled between zero and one, with one representing the worst case and zero representing the best case value, and the rescaled values were weighted and summed to calculate a single index.

Bryce et al. (2014) presented a probabilistic approach to include the use and maintenance phase into the network-level pavement management process. A Monte Carlo simulation was used to develop histograms of energy consumption for several levels of pavement maintenance and rehabilitation, as well as distributions representing the energy consumption from vehicles traveling along the pavement. The models developed by Chatti and Zaabar (2012) were used to estimate the additional fuel consumption due to an increase in pavement roughness. A benefit of using the probabilistic approach that was cited by Bryce et al. (2014) is that the relative risk associated with each pavement management decision can be evaluated along with the expected value for each criterion.

### ***13.6.3 Strategic Level***

Successful implementation of pavement management requires the establishment of strategic planning and defining goals and objectives, which all occurs at the strategic level. The AASHTO Asset Management Implementation Guide (AASHTO



2011) discusses the importance of planning at the strategic level. Strategic planning is an organization's process of defining its strategy, or direction, and making decisions on allocating its resources to pursue this strategy. Strategic planning should clarify the goals, mission, vision, value and strategies of the organization, as well as the performance measures used to evaluate progress toward each of the goals.

Defining performance measures that link an agencies goals and objectives with a level of achievement is critical for successful sustainable pavement management. In order to demonstrate this, the goals, objectives and measures that can be related to pavement management for the Georgia Department of Transportation (GDOT) are presented in Table 13.1. The goals, objectives and measures for GDOT were taken from a document published online that defines the agencies strategic plan (GDOT 2011). Furthermore, the performance measures are published online and updated as new data becomes available. Although GDOT does not have any objective specifically related to the environmental component of sustainability, it is clear from the structure of Table 13.1 how such an objective can be developed under a strategic goal.

### **13.7 Making Pavement Management Systems Sustainable with an Organization**

The structure of an organization is critical to successful sustainable pavement management and the implementation of sustainable objectives into the pavement management business processes. Integrating sustainability considerations into pavement management implies collecting and managing data that has not traditionally being part of pavement management, such as the environmental input and outputs of the various process. As with any infrastructure management system, a pavement management system relies on three fundamental components: processes, people and technology. There must also be a commitment to adequate funding. If any of these are lacking, there is a high probability that the system will not be successful (Flintsch et al. 2007).

The best technology in the world will ultimately fail if implemented in an environment where there are no people to run it, or where the business processes are not in place to utilize it. Furthermore, executives and managers need to be demonstrably committed to the system, both in their relations with external stakeholders and internally in their agency through good management principles. Policies should explicitly state the goals and objectives of the organization in regard to pavement asset management, and procedures should detail exactly how the pavement management processes can help achieve these goals. There has to be a specific organizational unit that have explicit responsibility for the processes and data, and is staffed with well-qualified and trained personnel, who are pro-active in developing and expanding the system. Finally, the data collection equipment and

**Table 13.1** GDOT strategic goals, objectives and performance measures

Strategic goal	Strategic objectives	Performance measures
Taking care of what we have in the most efficient way possible	Maintain interstates at a condition $\geq 75$	Average condition rating on all interstates
	Maintain state owned multi-lane non-interstate routes at a condition $\geq 70$	Average condition rating on multi-lane non-interstate routes
	Maintain state-owned bridges such that they meet a determined standard as defined by their strength and their condition	Percent of state-owned bridges that meet or exceed a determined standard based on strength and deck condition; defined as follows: <ul style="list-style-type: none"> <li>• Deck condition on Interstates <math>\geq 7</math></li> <li>U.S. Routes <math>\geq 6</math></li> <li>State Routes <math>\geq 5</math></li> <li>Off-System State-Owned <math>\geq 5</math></li> <li>or</li> <li>• Interstates, U.S. routes, state routes and off-system state owned bridges that are not posted (posting code = 5)</li> </ul> Target is $\geq 85\%$ of the bridges meeting this criteria with no Interstate bridge postings
Planning and constructing the best set of mobility-focused projects we can, on schedule	Complete plan development and construction of projects per the programmed year in the currently approved statewide improvement program	Percent of right of way authorized on schedule per the approved statewide improvement Program with a target of 80 %
		Percent of authorized on schedule per the approved statewide improvement program with a target of 80 %
		Percent of projects under construction completed on Schedule
		Comparison of award amount to final cost
	Maintain or improve the percentage of survey respondents that give GDOT a grade of A or B for meeting transportation needs in Georgia (customer service objective)	Percent of public opinion poll survey respondents that give GDOT a grade of A or B in meeting transportation needs in Georgia

hardware and software should be fit for purpose, actively used, and properly maintained and managed and managed. These elements are essential in ensuring sustainability of the pavement management process (Flintsch et al. 2007).

### 13.8 Conclusions

Sustainable pavement management as a business practice is about facilitating pavement investment tradeoffs considering the triple bottom line of sustainability during the design, construction, maintenance and rehabilitation of pavements. The consideration of sustainability goals for managing pavement assets requires setting targets for and measuring the economic, environmental, and social performance of the competing pavement investments. Many decision support tools have been developed to inform the tradeoff between these factors; these include tools for LCCA and LCA. Tools for handling the social impact are less developed but are starting to show in the research literature. Factors that are key to successful sustainable pavement management include management buy-in, maintaining clear strategic goals, quantifiable strategic objectives, and clear performance measures, appropriate technologies for data collection and analysis, and well-trained and motivated personnel.

### References

- AASHTO. (2011). *Transportation asset management guide, a focus on implementation*. Washington, DC: American Society of State Highway and Transportation Officials.
- ASCE. (2012). *American Society of Civil Engineers*. Retrieved October 8, 2012, [Online] Access: <http://www.asce.org/sustainability/> [Accessed].
- ASTM International. (2011). *ASTM standard D6433: Standard practice for roads and parking lots pavement condition index surveys*. West Conshohocken, Pennsylvania: ASTM International.
- Bryce, J., Katicha, S., Flintsch, G., Sivaneswaran, N., & Santos, J. (2014). *Probabilistic lifecycle assessment as a network-level evaluation tool for the use and maintenance phases of pavements, 93rd Annual Meeting of the Transportation Research Board*. Washington, D.C.
- Butt, A., Shahin, M., Carpenter, S. & Carnahan, J. (1994). *Application of Markov process to pavement management systems at the network level*. San Antonio, TX.
- California Energy Commission. (2014). *Environmental justice*. Retrieved January 25, 2014, [Online] Access: [http://www.energy.ca.gov/public\\_adviser/environmental\\_justice\\_faq.html](http://www.energy.ca.gov/public_adviser/environmental_justice_faq.html)
- Cambridge Systematics Inc. (2002). *Transportation asset management guide* (Vol. 1), Washington, DC: American Association of State Highway and Transportation Officials.
- Chamorro, A., & Tighe, S. L. (2009). Development of a management framework for rural roads in developing countries. *Transportation Research Record of the National Academies*, 2093, 99–107.
- Chatti, K., & Zaabar, I. (2012). *Estimating the effects of pavement condition on vehicle operating costs*. Washington, DC: Transportation Research Board of the National Academies.

- Chen, C., & Flintsch, G. (2012). Fuzzy logic pavement maintenance and rehabilitation triggering approach for probabilistic life cycle cost analysis. *Transportation Research Record: Journal of the Transportation Research Board of the National Academies*, 1990, 80–91.
- Diefenderfer, B., Apeageyi, A., Gallo, A., Dougald, L., & Weaver, C. (2012). In-place pavement recycling on I-81 in Virginia. *Transportation Research Record: Journal of the Transportation Research Board*, 2306, 21–27.
- Evans, L. R., et al. (2009). *NHTSA tire fuel efficiency consumer information program development: phase 2—effects of tire rolling resistance levels on traction, treadwear, and vehicle fuel economy*. East Liberty, OH: National Highway Traffic Safety Administration.
- Federal Highway Administration. (2013). *Transportation performance management: life-cycle cost analysis software*. Retrieved December 1, 2013, [Online]. Access: <http://www.fhwa.dot.gov/infrastructure/asstmgmt/lccasoft.cfm>
- FHWA. (1998). *Life cycle cost analysis in pavement design demonstration project 115—participant handbook*, s.l.: FHWA.
- Flintsch, G., McPherson, K., & Bennett, C. (2007). *Making road management systems successful*. s.n.: Washington, DC.
- Flintsch, G. W., & Chen, C. (2004). “Soft computing applications in infrastructure management. *ASCE Journal of Infrastructure Systems*, 10, 157–166.
- Galenko, A., Pilson, C., & Scheinberg, T. (2013). *Identifying the optimal mix of highway asset maintenance activities based on performance targets or budget constraints*. Proceedings of the Transportation Research Board of the National Academies, Washington, DC.
- GDOT. (2011). *Transportation asset management—the strategic direction of georgia department of transportation*, Atlanta, GA: Division of Organizational Performance Management.
- Giustozzi, F., Crisino, M., & Flintsch, G. (2012). Multi-attribute life cycle assessment of preventive maintenance treatments on road pavements for achieving environmental sustainability. *International Journal of Lifecycle Assessment*, 17, 409–419.
- Goodwin, P., & Wright, G. (1998). *Decision analysis for management judgment* (2nd ed.). West Sussex: John Wiley and Sons.
- Hallin, J. et al. (2011). *Guide for pavement type selection: NCHRP Report 720*, Washington, DC.: Transportation Research Board of the National Academies.
- Hammarström, U., Eriksson, J., Karlsson, R., & Yahya, M. (2011). *Rolling resistance model, fuel consumption model and the traffic energy saving potential from changed road surface conditions*. Linköping: Swedish National Road and Transport Research Institute.
- Horvath, A. (2003). *Life-cycle environmental and economic assessment of using recycled materials for asphalt pavements*. Berkeley: University of California Transportation Center.
- Huang, Y., Bird, R., & Heidrich, O. (2009). Development of a life cycle assessment tool for construction and maintenance of asphalt pavements. *Journal of Cleaner Production*, 17, 283–296.
- Hudson, Hass, & Uddin. (1997). *Infrastructure management: Integrating design, construction, maintenance, rehabilitation, and renovation*. New York: McGraw Hill.
- International Organization for Standardization. (2006). *Environmental Management—life cycle*. s. l.: ISO Standard 14040.
- Izevbekhai, B. (2012). *Concrete paving and texturing for sustainability*. Presented at Center For Transportation Studies Research Conference, Minneapolis, MN.
- Jeon, C. M., Amekudzi, A. A., & Vanegas, J. (2006). Transportation system sustainability issues in high, middle and low income economies: case studies from Georgia (U.S.), South Korea, Colombia, and Ghana. *ASCE Journal of Urban Planning and Development*, 132(3), 172–186.
- Keeney, R., & Raiffa, H. (1993). *Decisions with multiple objectives: preferences and value tradeoffs*. Cambridge, UK: Cambridge University Press.
- Lahdelma, R., Salminen, P., & Hokkanen, J. (2000). Using multicriteria methods in environmental planning and management. *Environmental Management*, 26(6), 595–605.
- Lamprey, G., Ahmad, M., Labi, S., & Sinha, K. (2005). *Life cycle cost analysis for INDOT pavement design procedures*. West Lafayette: Purdue University.

- Lenzen, M. (2008). Errors in conventional and input-output-based life-cycle inventories. *Journal of Industrial Ecology*, 4(4), 127–148.
- Li, Z., & Sinha, K. C. (2004). *Methodology for the development of a highway asset management system for Indiana: Publication FHWA/IN/JTRP-2003/21*, West Lafayette, Indiana: Joint Transportation Research Program, Indiana Department of Transportation and Purdue University.
- Muench, S. T., Anderson, J., & Bevan, T. (2010). Greenroads: A sustainability rating system for roadways. *International Journal of Pavement Research and Technology*, 3(5), 270–279.
- Pantelias, A., Flintsch, G. W., Bryant, J. W., & Chen, C. (2009). Asset management data practices for supporting project selection decisions. *Public Works Management Policy*, 13(3), 239–252.
- Park, K., Hwang, Y., Seo, S., & Seo, H. (2003). Quantitative assessment of environmental impacts on life cycle of highways. *ASCE Journal of Construction Engineering and Management*, 25–31.
- Patrick, J., & Arampamoorthy, H. (2010). *Quantifying the benefits of waste minimisation—NZTA Report 406*. Wellington, NZ: NZ Transport Agency.
- Santero, N., Masanet, E., & Horvath, A. (2011). Life-cycle assessment of pavements. Part I: Critical review. *Resources, Conservation and Recycling*, 5, 801–809.
- Shahin, M. (2005). *Pavement management for airports, roads, and parking lots*. New York: Springer.
- Smith, J., & Tighe, S. (2006). The analytical hierarchy process as a tool for infrastructure management. *Transportation Research Record, Journal of the Transportation Research Board*, 1974.
- Stich, B., Holland, J. H., Noberga, R. A., & O'Hara, C. G. (2011). Using multi-criteria decision making to highlight stakeholders' values in the corridor planning process. *The Journal of Transport and Land Use*, 4(3), 105–118.
- Suh, S. et al. (2004). System boundary selection in life-cycle inventories using hybrid approaches. *Environmental Science and Technology*, 38(3), 657–664.
- Transportation Research Board: Committee for the National Tire Efficiency Study. (2006). *Tires and passenger vehicle fuel economy: informing consumers, improving performance trb special Report 286*. Washington, DC: Transportation Research Board of the National Academies.
- Wang, T., Lee, I.-S., Kendall, A., Harvey, J., Lee, E.-B., & Kim, C. (2012). Life cycle energy consumption and GHG emission from pavement rehabilitation with different rolling resistance. *Journal of Cleaner Production*, 33, 86–96.
- Weiland, C., & Muench, S. (2010). Life-cycle assessment of reconstruction options for interstate highway pavement in seattle, Washington. *Transportation Research Record*, 2170, 18–27.
- Wu, Z., & Flintsch, G. (2009). Pavement preservation optimization considering multiple objectives and budget variability. *ASCE Journal of Transportation Engineering*, 135(5), 305–315.
- Zhang, H., Lepech, M., Keoleian, G., Q. S., & Li, V. (2010). Dynamic life-cycle modeling of pavement overlay systems: Capturing the impacts of users, construction, and roadway deterioration. *ASCE Journal of Infrastructure Systems*, 16(4), 299–309.
- Zietsman, J., Rilett, L., & Kim, S.-J. (2006). Transportation corridor decision making with multi attribute utility theory. *International Journal of Management and Decision Making*, 7(2/3), 254–266.

# Chapter 14

## Sustainable Pavement Preservation and Maintenance Practices

Douglas D. Gransberg, Susan L. Tighe, Dominique Pittenger and Maria Catalina Miller

**Abstract** This chapter discusses the state-of-the-practice in sustainable pavement maintenance and preservation. Its focus is on quantifying and understanding how pavement preservation and maintenance practices minimize environmental impacts. The Federal Highway Administration (FHWA) differentiates between pavement preservation and pavement maintenance and uses this to allocate federal funds accordingly. While Canadian agencies recognize and practice the concepts of pavement preservation, there is no regulatory differentiation between it and maintenance as compared to the US. Pavement preservation promotes environmental sustainability by conserving energy, virgin materials, and reducing greenhouse gases by keeping good roads good. Therefore, a sustainable pavement maintenance program should consider allocating personnel and resources to pavement preservation.

### 14.1 Introduction

Increasing societal awareness of the environmental effects of constructing, operating, and maintaining the highway infrastructure has led to new demands on transportation agencies to conduct their business in a more sustainable fashion. One key approach is for agencies to utilize a pavement preservation program, restoring pavements while still in good condition and extending their service life. The United

---

D.D. Gransberg (✉)  
Construction Engineering, Iowa State University, Ames, IA, USA  
e-mail: dgran@iastate.edu

S.L. Tighe  
Civil Engineering, University of Waterloo, Waterloo, ON, Canada

D. Pittenger  
College of Engineering, University of Oklahoma, Norman, OK, USA

M.C. Miller  
Department of Civil, Construction, and Environmental Engineering, Iowa State University, Ames, IA, USA

States (US) Federal Highway Administration (FHWA) considers pavement preservation a proactive approach to maintaining highways. Pavement preservation and maintenance treatments usually provide the least expensive pavement management strategy available on a life cycle cost basis (FHWA 2005).

This chapter synthesizes the current state-of-the-practice in usage and quantification of pavement preservation and maintenance practices in the context of their environmental impact. “Sustainability” refers to promoting environmentally friendly practices that also provide technical and economic benefits. Kober (2009) posited that the overall impact of infrastructure construction and maintenance activities to the environment could be analyzed using the following seven sustainability impact factor areas:

- virgin material usage;
- alternative material usage;
- program for pavement in-service monitoring and management;
- noise;
- air quality/emissions;
- water quality and energy usage.

The remainder of the chapter will examine the relationship between the above impact factors and the suite of typical pavement preservation and maintenance practices for all pavement types including: asphalt, concrete, composite, surface treated and gravel roads and pavements. The objective is to furnish a relative comparison of sustainability that can be used by public agencies to make pavement preservation treatment selections based on sustainability as well as cost and technical characteristics.

## 14.2 Background

Pavement infrastructure is critical to quality of life and prosperity of society. As the pavement structure deteriorates over time, proper pavement preservation and maintenance is necessary to achieve a high-performing, safe, and cost effective pavement network for the users. In a society today resources and funding are limited, making it important for transportation agencies to seek ways to utilize the resources to maximize benefits as part of daily operation. At the same time, attention to the notion of environmental sustainability has also increased. Environmental sustainability has been defined by the Brundtland Commission as “[meeting] the needs of the present without compromising the ability of future generations to meet their own needs” (Brundtland 1987). Recently, the FHWA defined sustainable transportation as “providing exceptional mobility and access in a manner that meets development needs without compromising the quality of life of future generations. A sustainable transportation system is safe, healthy, affordable, renewable, operates fairly and limits emissions and the use of new and nonrenewable resources” (Harmon 2010).

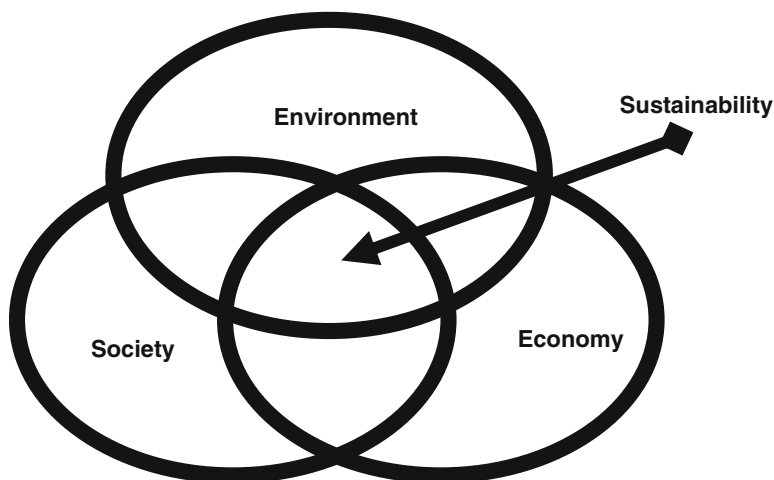

**Fig. 14.1** Fundamental sustainability model (adapted from CH2 M Hill 2009)

The basis of environmental sustainability consists of the three elements shown in Fig. 14.1: economy, society, and environment. Sustainable pavement preservation and maintenance are a subset of sustainable transportation where the impacts of the treatments on the economy, environment and social equity are defined and evaluated. It can also be evaluated according to the technical and economic effectiveness and the associated impacts on the natural environment (Jeon 2005). It should be noted that a study of state DOTs indicates that while environmental sustainability is not explicitly mentioned in the mission and vision statements of most agencies, many do include the three elements (Amekudzi 2007; Ramani et al. 2009).

### ***14.2.1 Sustainability in Transportation***

The concept of environmental sustainability and how it can be employed in various practice areas is gaining wide support from the general public, governments and professionals (Chan 2010; Muench 2010). The need to quantify sustainable practices is also challenging and requires a holistic approach. The initiatives by LEED™ (USGBC 2010), Greenroads (Muench 2010), GreenLITES (NYSDOT 2009) and GreenPave (MTO 2010) certification programs are common examples of programs that promote and quantify sustainable practices (Chan 2010). In addition, life cycle assessment (LCA) is another approach for modeling and quantifying environmental inputs and outputs from pavements and assessing their impacts on the environment and humans. Examples include the LCA software tool *PaLATE* (Horvath 2009) which uses both industrial process models and an approach called environmental input-output (EIO) to develop life cycle inventories of inputs and



outputs). These and some other industry initiatives are described later. However, it is notable that while many of the environmental sustainability initiatives consider preservation and maintenance treatments and their contributions to long life pavements, there is limited explicit assessment of the treatments themselves in terms of environmental performance.

As noted in FHWA's newsletter, "Strategic, Safe and Sustainable: Today's Vision for Pavements", environmental sustainability is of critical importance (Stephanos 2009). It is noted in that article, in the new decade of environmental awareness, maximizing recycled materials in pavement construction and rehabilitation is a priority and this is further advanced through the FHWA participation in the Green Highways Partnership (GHP) which is an attempt to align various state specifications for using recycled materials. Other initiatives include using warm mix that generates fewer emissions and conducting research on expanding the types and amount of fly ash that can be used in concrete paving. Although these initiatives tend to focus primarily on usage in pavement construction and rehabilitation treatments, they are also an important part of pavement preservation and maintenance treatments.

Additionally, recent research in France and New Zealand (Ball et al. 2008) mirrors a US movement from solvent-based binders toward water-based emulsion binders for use in pavement preservation and maintenance treatments as a result of concern for the environment. Emulsions are "more... environmentally friendly than ...cut back asphalts" (James 2006). A New Zealand study confirmed this assertion when it found: "Current indications are that chip sealing emulsions typically would be classified as safe..." (Ball et al. 2008). Thus, adding an environmental sustainability factor to the pavement preservation and maintenance decision-making process is both timely and appropriate.

### ***14.2.2 Pavement Preservation Theory***

Historically, most transportation agencies in North America would allow their pavements to deteriorate to fair or poor condition (Beatty et al. 2002). As a result of the national pavement preservation initiative, funding agencies are becoming familiar with the cost effectiveness of using preventive maintenance to preserve the infrastructure and are finding that chip seal research translates into a worthwhile investment. Figure 14.2 illustrates the concept of pavement preservation, where each dollar spent on maintenance before the age of rapid deterioration saves future rehabilitation costs (Hicks 1997) and could conceivably save even more when user delay and traffic control costs are added to the bottom-line.

One can see from Fig. 14.2 that the primary notion is to invest in keeping the road in good condition as long as possible. If successful, the overall sustainability of the network can potentially greatly enhanced by the reduction in the use of virgin materials and energy. The environment benefits from potential reductions in greenhouse gas emissions, hazardous material exposure, and deleterious construction

**Fig. 14.2** Pavement preservation model

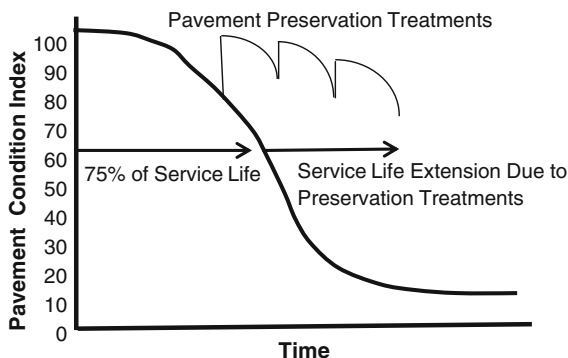

operations that expose the soil to erosion. Society can benefit where preservation results in reduced times of traffic disruption, which translate into fewer work zone accidents and a drop in injuries and/or fatalities. Finally, the public agency is better able to stretch its limited funding farther and address both replacement and capacity issues in its construction program. In asset management terms, pavement preservation enhances the overall condition of the network and simplifies resource distribution decisions. Thus, optimization of pavement preservation practices and keeping them adequately funded has the potential to improve sustainability.

### 14.3 Sustainability Impact Factor Areas

Measuring environmental sustainability is an emerging field in the transportation industry, and even more so with respect to the pavement maintenance treatment selection process. The literature seems rife with newly coined terms to describe a given treatment's impact on the environment (Takamura et al. 2001; James 2006; Ball et al. 2008; Chaignon and Mueller 2009; Muench 2010; Lane 2009). "The terms 'Green', 'Sustainable Development', 'Environmental Impact', 'Energy Efficiency', 'Global Warming', 'Greenhouse Gases', and 'Eco-efficiency', are becoming more widely recognized..." (Chehovitz and Galehouse 2010).

Unfortunately, each article or manual focuses its evaluation of environmental impact on a different set of impacts. For example, Takamura et al. (2001) coined the term "eco-efficiency" to describe the comparative analysis of six parameters: virgin material consumption, energy consumption, land use, emissions, toxicity, and risk potential. Pittenger's research (2010) included virgin material consumption, life cycle cost, and a factor from the Greenroads certification program (Muench 2010); whereas Chehovitz and Galehouse (2010) confined their analysis to greenhouse gas emissions and energy consumption. Thus, it is difficult to adopt a single, universally-recognized term to identify the process of evaluating competing pavement

preservation and maintenance treatment options on the basis of relative environmental sustainability. As a result, this report will use the term “environmental performance” to globally describe attributes of various treatments that accomplish one or more of the following outputs:

- Reduce the impact on the environment by minimizing the consumption of energy and virgin materials.
- Reduce the amount of harmful substances that are produced during manufacturing, transportation, and installation of the given treatment.
- Enhance the potential for increase safety for the traveling public and maintenance work crews by minimizing the amount of time traffic is disrupted for maintenance operations.

The American Association of State Highway and Transportation Officials (AASHTO) Center for Environmental Excellence (CEE) provides an excellent basis for identifying and promoting environmental excellence in the efficient delivery of transportation services (Kober 2009). The CEE evaluates sustainability parameters through identifying focus areas. Consequently, seven sustainability impact factor areas identified by the CEE will be considered in this synthesis. Each one of the areas is described herein and how they relate to pavement preservation and maintenance treatments. It should be noted that life cycle assessment tools such as the ISO 14040 Standard are becoming more available and many of these do cite other environmental sustainability impact factors (International Organization for Standardization (ISO) 2006). However, for the purpose of this discussion, the seven aforementioned factors have been examined.

- Virgin material usage examines reducing the need to use non-renewable resources. Pavement materials can be expensive and some resources may be limited, so it is important to make good utilization of available materials. The primary focus of this area is to consider the reduced need for virgin material usage and demand of virgin materials for treatments. Many maintenance treatments involve in-place recycling, which enables re-use of the materials already committed to roadways, although they also typically require some new materials as well. Prolonging the time between major rehabilitation and reconstruction through proper pavement treatment selection is an effective way to reduce virgin material usage.
- Alternative Material Usage looks at the opportunity to replace virgin materials with recycled materials and as well to use nontraditional materials in the pavement structure during preservation and maintenance. This could mean incorporating Reclaimed Asphalt Pavement (RAP), Recycled Concrete Aggregate (RCA), Recycled Asphalt Shingles (RAS), Recycled Rubber Tire (RRT), glass, or any other materials that might be appropriate. Proper processing of these materials can result in equivalent performance to virgin aggregate (Infraguide 2005). Careful blending and crushing of recycled materials is required to achieve consistent gradation and performance of the material (Infraguide 2005).

- Programs for Pavement In-Service Monitoring and Management are required to alert agencies in a timely manner to pavement deterioration so that they can intervene with preservation treatments before the road becomes so bad that preservation is no longer an option. In short, they support putting the right treatment on the right pavement at the right time. Robust information systems help determine existing and forecasted pavement conditions so that decisions can be accurately made and funds programmed for network improvements. Pavement in-service monitoring and management would consider the life cycle and associated serviceability of the treatment.
- Noise is defined as the unwanted or excessive sound associated with pavement construction and improvements. Studies show that the most pervasive sources of noise in the environment relate to transportation. Therefore, noise is examined as an environmental sustainability factor area whereby pavement preservation and maintenance treatments are evaluated on their noise impacts (CEE 2010a).
- Air Quality/Emissions examine six principal air pollutants, namely carbon monoxide, lead, nitrogen dioxide, ozone, particulate matter and sulfur dioxide (CEE 2010b). The intent of this factor is to assess each pavement preservation and maintenance treatment in terms of these pollutants. This would involve both calculations for the air quality/emissions for the equipment and materials. Also considered would be the associated impact the treatments have on the travelling public in terms of emissions associated with traffic delays due to the treatment placement, Part of the calculation of this factor would be the preventive maintenance treatment's service life.
- Water Quality evaluates the effects of transportation-related impacts associated with alternative maintenance strategies and materials. Regulatory requirements relate to the operation and maintenance of municipal storm sewer systems, storm water discharge associated with construction activities, and effluent standards related to the total maximum daily effluent discharge standards. Treatments and programs should be evaluated for their individual and collective effect on these resources (CEE 2010c).
- Energy Usage relates to the quantification of cumulative energy usage of the pavement preservation and maintenance treatment throughout the life cycle. Energy usage is important in its correlation to emissions of greenhouse gases and their relationship to climate change.

## 14.4 Pavement Preservation and Maintenance Treatments

A variety of different treatments are available to transportation agencies, and their use is determined according to factors of traffic, climate, available materials, etc. Criteria of environmental criteria do not currently play a part in treatment selection. Table 14.1 summarizes responses from a survey conducted in 2010 regarding which pavement preservation and maintenance practices are most commonly used by state

**Table 14.1** Summary of pavement preservation and maintenance techniques in survey

Surface type	Technique most often cited			Technique least often cited		
	Regrading	Regravel	Dust palliative	Ota seal	Other	Other
Gravel	Chip seal hot patches	Slurry seal cold patches	Microsurfacing Asphalt level-up	Fog seal thin hot mix overlay	Crack seal other	Crack seal other
Surface treated Asphalt	Chip seal hot patches	Slurry seal cold patches	Microsurfacing Asphalt level-up	Fog seal thin hot mix overlay	Crack seal other	Crack seal other
Concrete	Diamond grinding shotblasting	Milling mud jacking	Thin PCC overlay Dowel bar retrofit	Joint sealing	Crack seal other	Crack seal other
Composite	Chip seal hot patches	Slurry seal cold patches	Microsurfacing Asphalt level-up	Fog seal thin hot mix overlay	Crack seal other	Crack seal other

and provincial DOT's for gravel, surface treated, asphalt, concrete and composite pavements (Tighe and Gransberg 2011). The survey was directed to pavement maintenance practitioners in state, provincial, federal and selected transportation agencies in the US and Canada and it provided 49 responses from 42 U.S. state DOTs and 7 Canadian provincial ministries of transportation (Tighe and Gransberg 2011).

#### ***14.4.1 Treatment Selection and Usage***

Normally the agency will consider many factors when determining which treatments should be used. These factors may include: cost of treatment, type and extent of distress, traffic type and volume, climate, existing pavement type, expected life, availability of qualified contractors, availability of quality materials, time of year, pavement noise, facility downtime (user delays) surface friction, anticipated level of service and other project specific conditions (Moulthrop 2007). As noted this list is extensive but does not include environmental sustainability. Training and information that quantifies the importance of preservation and maintenance treatments in respect to environmental sustainability impact factor areas is needed to furnish an opportunity to evaluate environmental sustainability and the associated agency will use its established procedures, guidelines and specifications to select the appropriate treatment (Hicks et al. 1997).

A variety of program and technical guidance is available for support and training of personnel involved in preventive maintenance treatment selection, placement, inspection, etc. For example, the California DOT (Caltrans) Maintenance Technical Advisory Guides for Flexible Pavements and Rigid Pavements guidelines serve as good documents for evaluating materials and treatment selection (Caltrans 2008a, b). In addition, there are several FHWA Manuals of Practice on various preventive maintenance techniques as summarized in Table 14.2. Other documents include: Materials and Crack Seal Application (FHWA 2001), Joint Sealing in Portland Cement Concrete Pavements (FHWA 2002), Gravel Roads Maintenance and Design Manual (FHWA 2000), NCHRP studies, 20-07 on Pavement Preservation, Practices, Research Plans and Initiatives (Peshkin and Hoerner 2005) and NCHRP 342, Chip Seal Best Practices also provide valuable state-of-the-art information (Gransberg 2005). While these documents provide an excellent basis for the planning, design and construction of the treatment, there is no specific reference to environmental sustainability and how it relates to the identified environmental sustainability impact factor areas.

Furthermore there are several studies which discuss pavement preservation treatments and performance but environmental sustainability is not evaluated or considered in the decision-making process (Galehouse 2005). In addition, previous NCHRP studies, 20-07 on Pavement Preservation, Practices, Research Plans and Initiatives (Peshkin 2005) and NCHRP 342, Chip Seal Best Practices also provide valuable state-of-the-art information (Gransberg 2005).

**Table 14.2** Pavement preservation checklist series (Newman 2010)

Publication title	Publication number	Series number
Crack seal application	FHWA-IF-02-005	1
Chip seal application	FHWA-IF-02-046	2
Thin hot mix Asphalt overlay	FHWA-IF-02-049	3
Fog seal application	FHWA-IF-03-001	4
Microsurfacing application	FHWA-IF-03-002	5
Joint sealing PCC pavements	FHWA-IF-03-003	6
Diamond grinding of Portland cement concrete pavements	FHWA-IF-03-040	7
Dowel-bar retrofit for Portland cement concrete pavements	FHWA-IF-03-041	8
Partial-depth repair of Portland cement concrete pavements	FHWA-IF-02-042	9
Full-depth repair of Portland cement concrete pavements	FHWA-IF-03-043	10
Hot in-place Asphalt recycling application checklist	FHWA-IF-06-011	11
Cold in-place Asphalt recycling application checklist	FHWA-IF-06-012	12
Slurry seal application checklist	FHWA-IF-06-014	13

#### ***14.4.2 Evaluating Preservation Treatment Sustainability***

There are various aspects that must be considered when evaluating pavement preservation and maintenance practices for a respective pavement. Generally the expected service life of the treatment is a function of the traffic loading, subgrade soil and design thickness. Many factors can be considered including the pavement condition, roughness, skid number, structural adequacy and the associated impact on the level of service. Another important performance measure would be the calculation of the environmental sustainability impact factors of each treatment and the subsequent overall environmental sustainability impact of the treatment.

A very environmentally efficient pavement preservation measure is the use of shotblasting on asphalt and concrete pavements that have lost their skid resistance over time (Transport Canada 2003). This process consumes no materials as it recycles the steel abrasives used to restore macrotexture and microtexture on the pavement surface. On the other hand, microsurfacing is often used to restore skid resistance to sound asphalt pavements with polished aggregate. When it is compared to thin (less than 2" or 5 cm) hot-mix overlays, it consumes half the energy and virgin materials, emits about 60 % of the CO<sub>2</sub>, and reduces the potential for occupational illnesses and accidents by 63 % (Uhlman 2010). For example, another aspect which could be considered in environmental sustainability is the examination

of photo chemical ozone creation calculations and associated reductions in CO<sub>2</sub> and NO<sub>2</sub> emissions with respect to treatments such as microsurfacing (ISSA 2010).

Uhlman (2010) found that using microsurfacing as a pavement preservation treatment leaves a much smaller ecological “fingerprint” than the hot-mix overlay. The ecological fingerprint concept involves comparing various ecological factors related to a product or process how it impacts the environment. Stakeholders select the factors that impact future generations and show it as a three-dimensional figure. Although this concept is still somewhat developmental, it provides a methodology for looking at multiple factors and how they impact the environment (Schmidt 2004). Many factors determine which preservation and maintenance treated is best suited for each agency, some of these factors include: traffic, climate, available materials, cost of treatment, type and extent of distress, expected life, time of year, etc.

## 14.5 Opportunities to Improve Sustainability in Pavement Preservation and Maintenance

The literature is rich with information on practices that can improve sustainability that can and have been applied to highway design and construction. Each study represents an opportunity for maintenance engineers to potentially adopt aspects of the practices that can improve sustainability in maintenance and preservation. In other cases, the identified practices that can improve sustainability will likely need to be adapted or altered prior to their usage in pavement preservation and maintenance applications. Table 14.3 consolidates the information found in the literature and extends each study’s result to possible pavement preservation and maintenance applications. In most cases, the possible application was mentioned in the cited report or paper and, the mention took the form of a recommendation for additional research to validate the concept. The report by Denevillers (2010) detailed actual field testing of vegetable-based carbon emulsions.

One of the principles of environmental sustainability is to minimize the use of non-renewable resources. For example, the use of a renewable bio-fluxing agent as a prime coat was successfully demonstrated in Morocco, and also tested and used in chip seals on Route 960 in Saumur, France. The same is true for the bio-binder which has been successfully applied in Canada and 7 European countries. Though it is not in the table, it should be noted that it has successfully been used in road marking paints in France and England. It should also be noted, that many of these treatments should be evaluated in the broader environmental sustainability context as details in the literature were limited.

Table 14.3 illustrates that while fundamental research has been done on enhancing highway environmental sustainability through the use of recycled materials, alternative materials, and green construction technologies, the information necessary to extend these promising opportunities to pavement preservation and maintenance must still be developed through future research and field testing. Additionally the economic analyses contained in the above reports are very



**Table 14.3** Alternative, Recycled and Renewable Highway Design/Construction Literature Review Results

Material/technique	Literature cite	Possible preservation uses	Possible maintenance uses	Remarks
Bio-fluxing Agent	Denevillers 2010	Prime coat Chip seals Microsurfacing	Overlay tack coat Cold mix Warm mix	Trade name is Vegeflux <sup>®</sup>
Bio-binder	Denevillers 2010	Chip seals Microsurfacing	Cold in-place recycling Chip seals	Trade name is Vege-col <sup>®</sup>
Recycled concrete aggregate (RCA)	Gardner and Greenwood 2008	Whitetopping	Full-depth patching Partial-depth patching	RCA acts to sequester CO <sub>2</sub> in addition to recycling
Recycled glass gravel	Melton and Morgan 1996	Untried	Unbound base courses	Potential use on gravel roads
Fly ash	MnDOT 2005	Microsurfacing filler Slurry seal filler	Concrete maintenance mixes Microsurfacing	Widely used in a variety of products
Bottom ash	Carpenter and Gardner 2007	Microsurfacing mineral filler	Subbase under gravel surface	
Flue gas desulphurization gypsum	Benson and Edil 2009	Microsurfacing filler Slurry seal filler	Concrete maintenance mixes	
Kiln dust	MnDOT 2005	Prime coat Microsurfacing	Prime coat Microsurfacing	
Baghouse fines	ISSA 2010	Microsurfacing mineral filler Slurry seal filler	Untried	
Crushed slag	Chappat and Bilal 2003	Chip seal aggregate	Special binder road mix	
Ultra-high pressure water cutter	Pidwerbesky and Waters 2007	Restore macrotexture on chip seals	Retexture chip sealed roads prior to resealing.	Uses no virgin material and the sludge can be recycled as pre-coating for chip seal aggregates
Shotblasting	Transport Canada 2003	Restore microtexture on polished hot-mix Asphalt (HMA) and Portland cement concrete (PCC) pavements	Restore skid resistance on resealed PCC bridge decks	Uses no virgin material and the steel shot is recycled for reuse in the process

(continued)

**Table 14.3** (continued)

Material/technique	Literature cite	Possible preservation uses	Possible maintenance uses	Remarks
Recycled motor oil	Waters 2009	Dust palliative Otta seals	Otta seal as surface course	Motor oil is refined before use
Recycled tire rubber	Beatty et al. 2002	Chip seals Thin overlays	Chip seals Thin overlays	Also found to reduce road noise.

rudimentary. A recent study found that the standard FHWA-approved life cycle cost analysis method for new construction is not easily applied to pavement preservation projects (Pittinger 2010). As a result, rigorous research would be needed in order to apply a life cycle cost analysis algorithm which goes beyond merely looking at treatment construction costs and provides a rigorous methodology to assign a value to such things as carbon sequestration and resource renewability.

## 14.6 State-of-the Practice in Sustainable Pavement Preservation and Maintenance

The Transportation Research Board (TRB) of the US National Academies sponsored a study by the authors of this chapter to benchmark the state-of-the-practice in sustainable pavement preservation and maintenance practices in North America (Tighe and Gransberg 2011). As part of the study a survey was issued to all US state departments of transportation (DOT) and Canadian ministries of transportation (MOT). Responses were received from 42 US DOTs and 7 Canadian provincial MOTs, yielding a response rate of 84 and 70 % respectively. The survey was aimed at finding out three primary factors:

- Did the agencies have formal plans or policies to incorporate sustainability into the design and/or construction of pavement preservation treatments?
- What treatments were in use and how did the agencies view the level of sustainability of each treatment?
- How widespread was the use of the most sustainable treatments?

This section presents the environmental sustainability impact factor areas and the extent to which the TRB survey responses used them in their construction and maintenance decisions. Environmental stewardship considers the **use of renewable resources** at *below their rates of regeneration* and **nonrenewable resources** *below rates of development of substitutes* as noted by the first two environmental sustainability impact factor areas. In addition, the need to provide a clean environment from both an air quality and water quality perspective should be included in an environmental monitoring plan, as well as, including pollution prevention, climate protection, habitat preservation and aesthetics (Ramani et al. 2009).

### ***14.6.1 Recycling, Reusing, and Reclaiming of Existing Materials***

Recycling, reusing, and reclaiming of existing materials is crucial to advance sustainable development (Carpenter 2007). Construction materials can be expensive and some resources already have limited supply, making it important to make good utilization of available materials. One of the concerns with recycled material usage is potential uncertainty regarding the actual composition of a recycled material when compared to the virgin material it would replace. As a result, some agencies have withheld permission to use recycled materials while others have limited the amount of recycled material that can be incorporated into the pavement structure (Melton 1996; Smith 2009). Several successful uses of Recycled Asphalt Pavement (RAP), and Recycled Concrete Aggregate (RCA) are available in the literature and it can be noted that in addition to providing technical benefits, they improve the performance of the pavement (Scholz 2010; Smith 2009; Alkins et al. 2008; Tighe 2008; Beatty et al. 2002; Hansen and Copeland 2013). Further, both hot and cold in-place recycling are used by agencies for maintenance and rehabilitation of pavements, minimizing the amount of new materials for the work and reducing energy requirements for transporting materials to the jobsite. Table 14.4 shows that roughly 70 % of the responding agencies permit the use of recycled materials in their pavement preservation and maintenance programs.

### ***14.6.2 Alternative Materials***

Alternative materials also hold promise to be able to enhance environmental sustainability in pavement preservation and maintenance. Research has shown that materials such as RAS, recycled rubber tire, recycled glass, and reclaimed carbon from copier toner can be successfully incorporated into new pavements (Chan 2010). The incorporation of innovative materials can also potentially enhance pavement performance and reduce the demand for virgin materials (Horvath 2004). Thus, the survey sought to find the level of alternative material usage in agency pavement preservation and maintenance programs in Canada and the US. Table 14.9 shows that alternative materials have a lower level of use than recycled pavement materials, probably awaiting further research into their long-term performance in maintenance applications. Table 14.5 reflects the relatively widespread use of fly ash in concrete, as well as asphalt shingles and recycled rubber tires in HMA pavements. However, use of other alternative materials remains relatively uncommon. These results suggest that future research into applications and performance of alternative materials could be of value.

**Table 14.4** Summary of recycled and alternative materials authorization in pavement maintenance program

	Are recycled materials allowed in your current program?		Are alternative materials allowed in your current program?	
	No	Yes	No	Yes
Canada	0	7	2	5
USA	14	28	18	24
Total	14	35	20	29
Percentage (%)	28.6	71.4	40.8	59.2

**Table 14.5** Summary of recycled and alternative material usage by pavement type

Recycled/alt material	Gravel		Surface treated		Asphalt	
	Canada	USA	Canada	USA	Canada	USA
Fly ash	0	0	0	1	1	0
Shingles	0	1	0	1	2	13
Tire rubber	0	1	0	1	2	13
Glass	0	2	0	0	0	3
Foundry sand	0	0	0	0	0	1
Carbon	0	0	0	0	0	1
<i>Recycled/alt material</i>	<i>Concrete</i>		<i>Composite</i>		<i>Total</i>	<i>Percentage (%)</i>
	<i>Canada</i>	<i>USA</i>	<i>Canada</i>	<i>USA</i>		
Fly ash	4	21	0	1	28	57.1
Shingles	0	0	0	0	17	34.7
Tire rubber	0	0	0	0	17	34.7
Glass	0	1	0	0	6	12.2
Foundry sand	0	2	0	0	3	6.1
Carbon	0	0	0	0	1	2.0

### 14.6.3 Noise Pollution

Minimizing or eliminating noise pollution is another element of a sustainable design and construction program, and it follows that standards imposed on construction may also be applicable to maintenance operations. Table 14.6 shows the results of that portion of the survey. It shows that only about 21 % of the respondents felt that noise pollution is an important/very important issue in their agencies. Only 7 % were aware of noise standards for their agencies’ pavement maintenance operations; whereas over one third of the survey respondents did not

**Table 14.6** Summary of noise pollution measures

	How important is noise distribution during pavement maintenance operations in your agency?						Agency noise standards in effect					
	Very important	Important	Neutral	Not important	Not even considered	No opinion	Construction noise	Maintenance noise	Traffic noise	No noise standard	Don't know	
Canada	0	1	3	0	2	1	2	1	0	4	0	
US	4	4	12	0	4	11	7	2	3	11	15	
Total	4	5	15	0	6	12	9	3	3	15	15	
Percentage (%)	9.5	11.9	35.7	0.0	14.3	28.6	21.4	7.1	7.1	35.7	35.7	

**Table 14.7** Summary of water quality policies

	Water quality considered?			Agency water quality guidelines?		
	No	Yes	Don't know	No	Yes	Don't know
Canada	4	2	1	3	3	1
USA	8	17	12	5	17	15
Total	12	19	13	8	20	16
Percentage (%)	27.3	43.2	29.5	18.2	45.5	36.4

have any noise standards for maintenance operations. Relevant future research could help establish appropriate noise standards for construction and maintenance operations, and provide a tool for using noise considerations as part of treatment selection. As noted by the high “no opinion” or “don’t know” category, it would be suggested that education and training could be provided in this environmental sustainability impact factor area for maintenance personnel.

#### ***14.6.4 Water Quality***

For the environmental sustainability factor of water quality, there is a similar unfamiliarity among the survey respondents about how agency policies applied to maintenance activities. Based on this evaluation, there are no current measures available which quantify the effects of pavement maintenance and preservation on water quality. The data in Table 14.7 indicates that the pavement preservation and maintenance treatment’s impact on water quality is considered less than half the time. That is probably because less than half the responding agencies indicated that they have agency water quality guidelines. The fact that roughly a third of all respondents did not know if their agency considered water quality or had water quality guidelines validates the conclusion that coupling programmatic environmental sustainability with pavement preservation and maintenance programs has not yet happened in North America. Again, this would reinforce both the need to develop measures in this area for quantification.

#### ***14.6.5 Air Quality and Energy Use***

Table 14.8 shows that the news with regard to air quality is better. A little over 60 % of the agencies reported that they monitor air quality in the course of their pavement maintenance operations. However, only 25 % of the agencies consider energy usage when selecting pavement preservation and maintenance treatments. Both of these are areas where the use of preventive maintenance treatments in a pavement preservation program can have noticeable effect. Many of the treatments

**Table 14.8** Summary of air quality monitoring and energy usage

	Air quality monitoring?			Energy usage considered?		
	No	Yes	Don't know	No	Yes	Don't know
Canada	0	7	0	3	3	1
USA	2	20	15	15	8	14
Total	2	27	15	18	11	15
Percentage (%)	4.5	61.4	34.1	40.9	25.0	34.1

are emulsion-based, with comparatively low emissions during construction, although the emissions during bitumen manufacture can be significant. Similarly, providing quantitative measures for differences among energy use among the various treatments would be a valuable tool in treatment selection.

The recycled and alternative materials authorization is the most prevalent. Although it is not explicitly stated, the role of pavement in-service monitoring and pavement management is also common. If implemented properly, a pavement management program that improves sustainability emerges because the pavement monitoring system triggers pavement preservation activities, which in turn extend the service life of the pavement and reduce the impact to the environment in all categories. In short, keeping good roads good is the most effective way to sustain the service life of a road while reducing the consumption of energy, virgin materials, and nonrenewable resources, which automatically reduces air, water, and noise pollution.

A study of the Georgia DOT network-level pavement management system (Wang 2010) demonstrated that such a system also makes economic sense. The report found that a robust in-service pavement monitoring system “will help decision makers address the question of paying for roadway preservation now at a lower cost or later at a much higher cost” (Wang 2010). Further examination and quantification of this impact is required as the direct policies and practices to pavement preservation and maintenance treatments should be explicitly reviewed for these environmental sustainability impact factor areas. In terms of noise pollution, water quality and air quality, there is clearly an opportunity to incorporate these environmental sustainability impact factor areas into preservation and maintenance operations.

## 14.7 Rated Performance Versus Practices

The final portion of the survey sought to quantify the perceptions of pavement preservation and maintenance practitioners with regard to the environmental sustainability of their current practices. The analysis had two parts. First, the survey asked how they considered the contribution to overall environmental sustainability of commonly used practices. The study found that the Canadian and US practitioners agree that the two practices that contribute the greatest degree toward

**Table 14.9** Rated sustainability of common treatments

Pavement type	Percentage usage (%)	Rated sustainability		
		1 = very sustainable to 4 = not sustainable		
Asphalt		Combined	Canada	US
Chip seal	87.5	1.8	2.0	1.7
Thin overlay	93.8	2.0	2.3	1.9
Microsurfacing	84.4	2.1	2.0	2.1
Crack seal	53.1	2.2	2.0	2.2
Hot patches	87.5	2.4	2.2	2.5
Slurry seal	50.0	2.4	2.5	2.4
Fog seal	43.8	2.6	2.5	2.6
Cold patches	68.8	2.7	2.4	2.7
<i>Concrete</i>		<i>Combined</i>	<i>Canada</i>	<i>US</i>
Diamond grinding	92.6	2.0	2.3	2.0
Joint sealing	88.9	2.2	2.0	2.2
Crack seal	59.3	2.3	2.0	2.3
White topping	29.6	2.4	2.0	2.4
Shotblasting	22.2	2.4	2.0	2.5

promoting environmental sustainability are material quality and selection and maintenance timing.

Next the respondents were asked to rate the environmental sustainability of several common pavement preservation and maintenance treatments from an overall holistic approach based on their engineering judgment. Note the respondents all had extensive pavement maintenance experience and their experience was deemed to be key to the analysis. Table 14.9 shows the outcome of that exercise. The combined perception is that chip seals are the most sustainable treatment for asphalt pavements while diamond grinding is more sustainable for concrete pavements.

It is interesting to note that when the actual usage of each treatment is compared with its environmental sustainability ranking, a trend regarding fundamental practice of sustainable pavement preservation and maintenance programs can be found. Those trends for asphalt and concrete pavements are shown in Figs. 14.3 and 14.4. In both figures the trend is clear. The rated environmental sustainability of the treatment is directly proportional to its use. Therefore, even though the responding agencies did not indicate that formal environmental sustainability considerations or programs were a significant part of their program, it appears that they believe that treatments that they use most often are sustainable. When the asphalt overlay is compared to the chip sealing and microsurfacing, the focus is on expected service life rather than energy usage or virgin material usage.



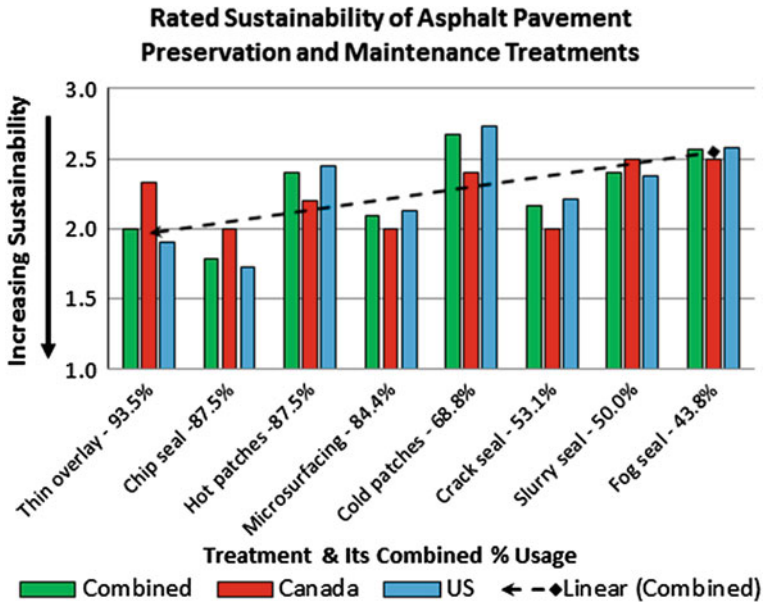

Fig. 14.3 Asphalt pavement trend in usage versus rated sustainability

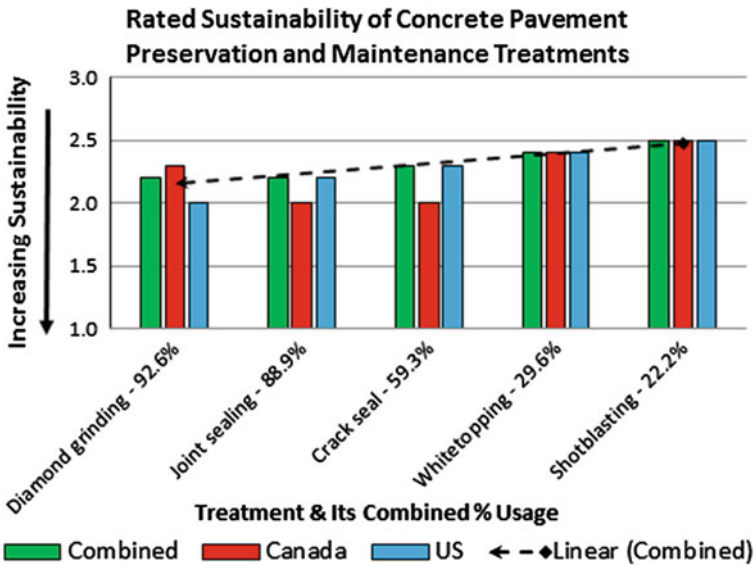

Fig. 14.4 Concrete pavement trend in usage versus rated sustainability

Furthermore, because agency maintenance budgets are usually fixed amounts that do not directly reflect the actual amount of maintenance needs, then using service life as the primary factor for sustainability may be a good approach. For example, in a life cycle assessment where a longer service life can compensate for the incremental increase in the amount of energy and virgin materials usage, and from the perspective of an agency pavement manager, it means that road will not need attention for an extended amount of time. Therefore, the observation that the perception of a treatment in terms of the environmental sustainability impact factor areas is directly proportional to its usage is validated.

## 14.8 Industry Initiatives to Measure Sustainability in Highways

As the concept of environmental sustainability becomes more important to highway agencies, they have become aware of the need to quantify their actions and programs in environmental terms. A number of different environmental sustainability measurement initiatives have been developed, providing rating systems or “score-cards” for agencies’ use. Four examples of environmental sustainability initiatives for highway pavements are Greenroads (Muench 2010), GreenLITES (NYDOT 2009), Green Guide for Road Task Force (TAC 2010), and GreenPave (MTO 2010). The study found that while these rating systems had some reference to pavement maintenance, the real focus was on new construction and that limited its utility for quantifying sustainability in pavement preservation treatments. Two other initiatives were found that have been developed by the private sector and are worth noting as they promise to provide a foundation for the future advancement of this topic. For more detailed information on pavement LCA, mostly applied to estimate GHG emissions, the readers are directed to the following chapters in this book:

- The Product Process Service Life Cycle Assessment Framework to Estimate GHG Emissions for Highways (Mukherjee and Cass)
- Pavement Life-Cycle Assessment (Parry and Huang)
- Application of LCA Results to Network-level Highway Pavement Management (Harvey, Wang and Lea)

Many commonly used preventive maintenance treatments are “greener” than major rehabilitation or reconstruction, conserving energy, virgin materials, and reducing greenhouse gases by keeping good roads good (Chehovitz 2010). Figure 14.5 shows of the type of comparative analysis that can be done if the information for each possible maintenance treatment was available. In this example, microsurfacing’s environmental footprint is shown to be among the lowest of three commonly used alternatives (Takamura 2001). The study developed “eco-efficiency” indices for the five categories shown as shown in the figure.

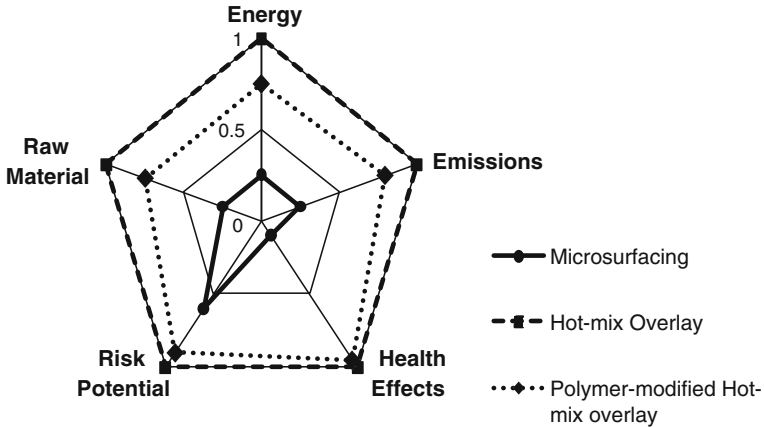

**Fig. 14.5** Microsurfacing ecological fingerprint compared to three types of pavement preservation overlays (after Takamura 2001)

Another factor that could have been included in the calculation is the reduced gas emissions due to microsurfacing's ability to greatly reduce traffic delays in work zones (Johnson et al. 2007). Additionally, the "risk potential" and "health effects" categories did not include the reduction in work zone accident risk inherent to a fast curing treatment like microsurfacing because the primary focus of the study was on accident reduction (Erwin and Tighe 2008). A benefit of having quantified environmental sustainability data is it provides the engineer with necessary information for justification to offset any marginal increase in construction cost of one treatment versus other lower priced alternatives.

It must be noted that all of the three treatments in Fig. 14.5 would be considered as part of a pavement preservation program (FHWA 2005). Therefore, if environmental sustainability was the primary decision factor and if the engineer could establish that performance was otherwise comparable, the radar diagram shows that microsurfacing would be the more sustainable option. Data are lacking to apply this analysis to the full suite of potential rehabilitation and maintenance treatments. Subsequent research could provide applicable values for all possible treatments in all seven environmental sustainability impact factor areas

## 14.9 Summary

Currently, public agencies in the US and Canada have done very little to extend the knowledge gained from research and practice in sustainable highway project delivery beyond construction completion and into the pavement preservation and maintenance phase of a road's life cycle. Thus, there are many opportunities for future research and enormous potential for agencies to accrue benefits in this area of

practice. These potential benefits are diverse and of strategic importance as they encompass improvements to virgin material usage, alternative material usage, pavement in-service monitoring and management, noise, air quality, water quality and energy usage. Treatments identified in this chapter are primarily related to preservation and maintenance. However, these are not exclusive to preservation and maintenance and can be used in pavement rehabilitation.

Optimization of pavement preservation practices and keeping them adequately funded can potentially improve pavement sustainability. Therefore, the bright light in this analysis is that North American transportation agencies are committed to the concept of preserving the network and have shown a willingness to invest in preservation as evidenced by the FHWA policy to permit federal-aid highway funding for preservation projects. Thus, the next step is to invest in the treatment types themselves and take pavement preservation and maintenance to an even higher level of sustainability by selecting treatments that minimize the impact to the environment.

## References

- Alkins, A., Lane, B., & Kazmierowski, T. (2008). *Sustainable pavements environmental, economic, and social benefits of in situ pavement recycling* (pp. 100–103). Transportation Research Record No. 2084. Washington, DC: National Academy of Sciences.
- Amekudzi, A., & Jeon, C. M. (2007). Evaluating transport systems sustainability: Atlanta metropolitan region, *Presented at 86th Annual Meeting of the Transportation Research Board*, Washington, D.C.
- Ball, G. F. A., Harrington, P. R., & Patrick, J. E. (2008). *Environmental effects of emulsions, land transport New Zealand research Report 343* (p. 47). New Zealand Transport Agency: Wellington, NZ.
- Beatty, T. L. et al. (2002). *Pavement preservation technology in France, South Africa, and Australia*, Report FHWA-PL-3-001 (p. 56). Office of International Programs, Federal Highway Administration, American Trade Initiatives, Alexandria, Va: Washington, D.C.
- Benson, C., & Edil, T. (2009). *Quantifying the benefits of using coal combustion products in sustainable construction* (p. 45). EPRI: Palo Alto, CA.
- Brundtland Commission. (1987). *World commission on environment and development. our common future*. Oxford England: Oxford University Press.
- California Department of Transportation. (2008a). Maintenance technical advisory guide (MTAG), *Flexible Pavement Preservations* (Vol. 1, 2nd ed.). Training Modules, California Department of Transportation, Office of Pavement Preservation, Division of Maintenance. Access: <http://www.dot.ca.gov/hq/maint/PavePres/ppindex.htm>
- California Department of Transportation. (2008b). *Maintenance technical advisory guide (MTAG), Rigid Pavement Preservation* (Vol. 2, 2nd ed.). California Department of Transportation, Office of Pavement Preservation, Division of Maintenance. Access: [http://www.dot.ca.gov/hq/maint/MTA\\_GuideVolume2Rigid.html](http://www.dot.ca.gov/hq/maint/MTA_GuideVolume2Rigid.html)
- Carpenter, A. C., & Gardner, K. H. (2007). Recycled material highway construction environmental assessment: life cycle based risk assessment of recycled materials in roadway construction. *Final Report for RMRC Research Project, 43, 12*.
- Center for Environmental Excellence (CEE) (2010a) “Noise,” American Association of State Highway and transportation, (AASHTO). Access: <http://www.environment.transportation.org/tools/print.aspx>

- Center for Environmental Excellence (CEE) (2010b) "Air Quality," (AASHTO). Access: <http://www.environment.transportation.org/tools/print.aspx>
- Center for Environmental Excellence (CEE) (2010c) "Water Quality/Wetlands," (AASHTO). Access: <http://www.environment.transportation.org/tools/print.aspx>
- Center for Environmental Excellence (CEE) (2010d) "Sustainability," (AASHTO). Access: [http://www.environment.transportation.org/environmental\\_issues/sustainability](http://www.environment.transportation.org/environmental_issues/sustainability)
- Chaignon, F., & Mueller, S. (2009). *Calculating CO<sub>2</sub>e emissions?*. Scottsdale, AZ: A discussion with the PPETG.
- Chan, P., & Tighe, S. (2010). *Quantifying pavement sustainability* (p. 5). Ontario: Ministry of Transportation of Ontario.
- Chappat, M., & Bilal, J. (2003). *Sustainable development, the environmental road of the future: Life cycle analysis*. Colas: The Road Forward.
- Chehovitz, J., & Galehouse, L. (2010). *Energy usage and greenhouse gas emissions of pavement preservation processed for Asphalt concrete pavements: Proceedings on the 1st International Conference of Pavement Preservation* (pp. 27–42). Newport Beach: California, April.
- Deneviller, C. (2010). *Renewable carbon-based binders for pavement preservation: Proceedings ISSA Annual Conference* (p. 31). Florida: Sunny Isles.
- Erwin, T., & Tighe, S. L. (2008). Safety effect of preventive maintenance: A case study of microsurfacing. transportation research record. *Journal of the Transportation Research Board* 2044, 79–86.
- Federal Highway Administration (FHWA). (2005). *Action pavement preservation definitions, Federal Highway Administration*. Access <http://www.fhwa.dot.gov/pavement/preservation/091205.cfm>
- Federal Highway Administration (FHWA). (2001) *Crack seal application, Pavement preservation checklist series* (Vol. 1), Publication No. FHWA-IF-02-005, p. 16.
- Federal Highway Administration (FHWA). *Joint sealing in Portland cement concrete pavements, Pavement preservation checklist series* (Vol. 6), Publication No. FHWA-IF-03-003, p. 34.
- Federal Highway Association (FHWA). (2000) *Gravel roads: Maintenance and design manual, Federal Highway Administration, South Dakota Local Transportation Assistance Program (SD LTAP)*, November 2000.
- Galehouse, L., King, H., Leach, D., Moulthrop, J. & Ballou, B. (2005). *Preservation maintenance treatment performance at 14 years*. Transportation Research Board.
- Gardner, K., & Greenwood, S. (2008). Sustainable highways through the use of carbon sequestering construction materials. *Final Report for RMRC Research Project, 35*, 43.
- Gransberg, D. D., & James, D. M. B. (2005). *Chip seal best practices, national cooperative highway research program synthesis* (Vol. 342, p. 124), ISBN 0-309-09744-4. Washington, D. C: Transportation Research Board, National Academies.
- Hansen, K. R., & Copeland, A. (2013). Annual Asphalt pavement industry survey on recycled materials and warm-mix asphalt usage: 2009–2012. *NAPA Information Series (IS)* (Vol. 138). MD: Lanham.
- Harmon, T. (2010). *Sustainable transportation* (p. 9). International Sustainable Pavements Workshop: Virginia Tech/Nottingham Transportation Engineering Center, Washington DC, January.
- Hicks, R. G., Dunn, K., & Moulthrop, J. S. (1997). Framework for *selecting effective preventive maintenance treatments for flexible pavements, transportation research record 1597* (pp. 1–10). Washington D.C: TRB, National Research Council.
- Horvath, A., Pidwerbesky, B. & Waters, J. (2004). *Sustainable Innovative Surfacing Treatments for Low Volume Roads*, Transportation Research Record 1989, TRB, National Research Council, Washington, D.C, 2007, pp. 1–10.
- Horvath, A. (2009). Pavement life-cycle assessment tool for environmental and economic effects. Retrieved April 2, 2009 from <http://www.ce.berkeley.edu/~horvath/palate.html>
- Infraguide. (2005). *Reuse and recycling of road construction and maintenance materials* (Vol. 11), Federation of Canadian Municipalities and National Research Council.

- International Organization for Standardization (ISO). (2006). *Environmental management—Life cycle assessment—principles and framework* (2<sup>nd</sup> ed.). International Standard ISO 14040, September 2006.
- International Slurry Surfacing Association (ISSA). (2010). *Inspector's manual for slurry systems* (p. 106). Annapolis, MD: International Slurry Surfacing Association.
- James, A. (2006). "Overview of Asphalt emulsion", *transportation research circular E-C102* (pp. 1–6). Washington, D.C: Transportation Research Board of the National Academies.
- Jeon, C., & Amekudzi, A. (2005). Addressing sustainability in transportation systems: Definitions, indicators, and metrics, *Journal of Infrastructure Systems*, 11, 31–50.
- Johnson, N., Wood, T. J. & Olson, R. C. (2007). *Flexible slurry-microsurfacing system of overlay preparation, transportation research record: journal of the transportation research board* (Vol. 1989, pp. 18–26). Washington, D.C: Transportation Research Board of the National Academies.
- Kober, W.W. (2009). The road to environmental stewardship via in-place pavement recycling, Midwestern States regional in-place recycling conference Bloomington, Minnesota, August 2009.
- Melton, J. S. & Morgan, T. (1996). Evaluation of tests for recycled material aggregates for use in unbound application. *Final Report of RMRC Project* (Vol. 6, p. 18).
- Ministry of Transportation (MTO). (2010). *Ontario's transportation technology transfer digest, ministry of transportation* (Vol 16, Issue 1). Winter 2010.
- Minnesota Department of Transportation (MnDOT). (2005). *Standard specifications for construction, minnesota* (p. 776). St. Paul, Minnesota: Department of Transportation.
- Moulthrop, J. S. & Smith, R. E. (2007). *State of the art and state of the practice in pavement maintenance*, Transportation Research Board.
- Muench, S. (2010). *Greenroads v1.0 Rating System*. Washington: University of Washington.
- New York Department Of Transportation. (2009). *NYDOT*. NY: GreenLITES Project Design Certificate Program, New York State Department of, Transportation (NYSDOT).
- Newman, C. (2010). *Pavement preservation checklist series*, Personal Communication.
- Peshkin, D. G., & Hoerner, T. E. (2005). *Pavement preservation: Practices, research plans, and initiatives*. Washington, D.C: National Cooperative Highway Research Program, Transportation Research Board, National Research Council.
- Pidwerbesky, B., & Waters, J. (2007). *Sustainable innovative surfacing treatments for low volume roads* (pp. 1–10). Washington, D.C: Transportation Research Record 1989, TRB, National Research Council.
- Pittenger, D. M. (2010). *Life cycle cost-based pavement preservation treatment design* (p. 67). Master's Thesis. Norman, Oklahoma: University of Oklahoma.
- Ramani, T., Zietsman, J., Eisele, W., Rosa, E., Spillane, D., & Bochner, B. (2009). *Developing sustainable transportation performance measures for TXDOT's strategic plan: Technical Report*. Austin: Texas Department of Transportation.
- Schmidt, I., Meurer, M., Saling, P., Kicherer, A., Reuter, W., & Gensch, C. O. (2004). SEEBalance® managing sustainability of products and processes with the socio-eco-efficiency analysis by BASF. *Green Management International*, 45, 79–94.
- Schol, T. V. (2010). Preliminary investigation of RAP and RAS in HMAC, Oregon Department of Transportation, February 2010.
- Smith, J., & Tighe, S. (2009). *Recycled concrete aggregate coefficient of thermal expansion: Characterization, variability and impacts on pavement performance* (Vol. 2113, pp. 53–61). Washington, D.C: National Academy of Sciences, Transportation Research Record.
- Stephanos, P. (2009). Focus: Strategic, safe, and sustainable: Today's vision for pavements, Federal Highway Administration, December 2009.
- Takamura, K., Lok, K. P., & Wittlinger, R. (2001). *Microsurfacing for preventive maintenance: eco-efficient strategy* (p. 5). Maui, Hawaii: International Slurry Seal Association Annual Meeting.

- Tighe, S., Hanasoge, N., Evers, B., Essex, R., & Damp, S. (2008). *Who thought recycled asphalt shingles (ras) needed to be landfilled: Why not build a road?*. Toronto: Transportation Association of Canada Conference Proceedings.
- Tighe, S. L. & Gransberg, D. (2011). *Sustainable pavement maintenance practices* (Vol. 365). Washington, D.C: NCHRP Research Results Digest.
- Transport Canada. (2003). *Runaway rubber removal and retexturing by shotblasting*, Pavement Maintenance Specification, Section PMS-5540, Civil Aviation International Aviation and Technical Programs, Ottawa, Ontario, Canada, May 2003, p. 3.
- Transportation Association of Canada (TAC). (2010). Green guide for roads, transportation association of Canada. Retrieved March 3, 2010 from [www.tac-atc.ca/english/projects/greenguide.cfm](http://www.tac-atc.ca/english/projects/greenguide.cfm)
- Uhlman, B. (2010). Eco-efficiency of microsurfacing, proceedings, AEMA-ARRA-ISSA annual meeting, sunny Florida: Isles, p. 56.
- United States Green Building Council USGBC. (2010). Green building by the numbers, US green building council (USGBC). Access: <http://usgbc.org/ShowFile.aspx?DocumentID=3340>
- Wang, Z., Tsai, Y., & Pitts, E. (2010). Pavement preservation: pay now or pay big later, compendium of papers from the First International Conference on Pavement Preservation. Newport Beach, California, April 2010, pp. 85–102.
- Waters, J. (2009). *Long-term dust suppression using the otta seal technique*, New Zealand Transport Agency Research Report 368 (p. 5199). NZTA: Wellington, New Zealand.

# Chapter 15

## Reclaimed Waste Materials in Sustainable Pavement Construction

Animesh Das and Aravind Krishna Swamy

**Abstract** This chapter provides an in-depth but brief overview on the possible use of various waste materials for sustainable pavement construction. It compiles a literature review on the research done on such materials and highlights the current issues.

### 15.1 Introduction

Pavement construction involves consumption of large quantity of construction materials. Some of these construction materials are available in natural form and some are manufactured (from naturally occurring raw materials). Due to the rapid growth of infrastructure, naturally available good quality construction materials are gradually becoming scarce. Consequently, there is an increase in the transportation cost for acquiring good quality materials. Thus, there is a need to develop or search for alternative materials for road construction.

On the other hand, large quantity of byproducts are generated from agricultural, construction and demolition, industrial and domestic sources (Aravind and Das 2004; Krishna Swamy and Das 2012; Arnold et al. 2008; CEMP 1999; Chimenos et al. 1999; DEFRA 2013a, b; Feng et al. 2013; Han 1993; Hassan 2005; Hill et al. 2001; Huang et al. 2007a; Lindsay and Logan 2005; Mauoin 2010; Mroueh and Wahlström 2002; Schimmolle et al. 2000; Stroup-Gardiner and Wattenberg-Komas 2013a; Su and Chen 2002). These byproducts are to be treated as waste materials

---

A. Das (✉)

Department of Civil Engineering, Indian Institute of Technology Kanpur,  
Kanpur 208016, India  
e-mail: adas@iitk.ac.in

A.K. Swamy

Department of Civil Engineering, Indian Institute of Technology Delhi,  
Hauz Khas 110016, New Delhi, India  
e-mail: akswamy@civil.iitd.ac.in



unless some ways are found out to utilize/recycle these materials. Safe disposal of waste material is a complex task—it involves issues related to availability of space, construction of long-term contamination-proof storage facility and so on. Thus, waste materials are constantly posing a serious threat to the civilization in terms of health, environmental and safety related problems. In recent years, significant research attention is being directed to assess whether such materials, after due processing, can be made safe and suitable for use in building infrastructure. Such an approach would help us to (i) reduce the storage and disposal problems with the waste materials, (ii) tackle increasing scarcity natural resource, (iii) save energy in construction, (iv) reduce greenhouse emission (Malhotra 2002), (v) reduce cost, (vi) protect the environment and so on.

This chapter provides a brief overview on the possible use of various waste materials reclaimed for sustainable pavement construction. It identifies the related issues and highlights the thought process involved in utilization of such materials in road construction. Though both bituminous and concrete pavements have been dealt in this chapter, detailed discussion on the use of alternative materials in concrete technology, ground improvement, soil stabilization, ground filling (embankment fill, compacted fill, bulk fill etc.) and road furniture have not been covered. Interested readers may refer elsewhere (for example, Arnold et al. 2008; Ashmawy et al. 2006; FHWA 2013a; Yoon et al. 2009 etc.) for further details.

## 15.2 General Framework for Utilization of Waste Materials in Road Building

As mentioned earlier, various wastes may originate from agricultural, construction and demolition, domestic and industrial sources. Figure 15.1 identifies some of the specific wastes from these sources, which may have application possibilities in road construction.

To ascertain whether a specific waste material can be used as a road construction material, its impact on health, safety and environment and its physical, chemical and engineering characteristics need to be evaluated. The following is a typical approach followed.

First, the availability and supply of the concerned waste material is evaluated. Then, it is checked whether the material is hazardous. That is, the toxicity, explosiveness, leaching potential, pH level, flammability, physical and chemical reactivity, corrosiveness, infectiousness, dust generation, odour etc. are evaluated (Apul 2004; Bloomquist et al. 1993; CEMP 1999; Eldin 2002; Hill 2004; Huang 2007a; Mroueh and Wahlström 2002; Peploe and Dawson 2006; Nelson et al. 2000).

If the material is adjudged as non-hazardous, further processing may be needed to convert it into usable form—the process may involve chemical, microbiological or temperature fixation. For some kind of a waste material detailed processing may

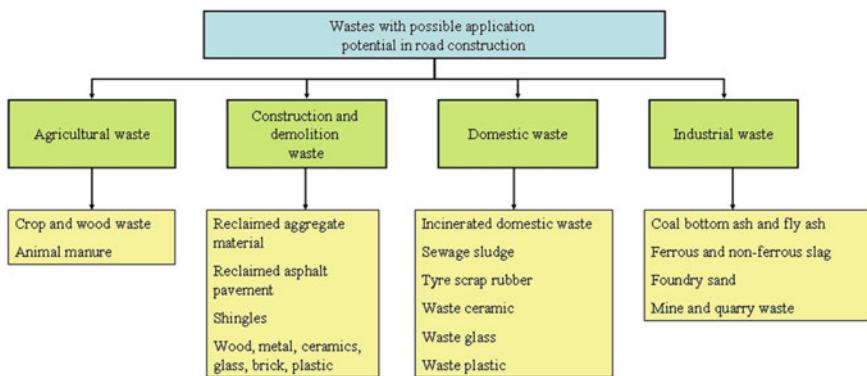

**Fig. 15.1** Various wastes which may have certain application potential in road construction

be needed, but for some material it can be used almost readily (for example, reclaimed aggregate material (RAM) after grinding and mixing can be directly used as a replacement of aggregates in asphalt mix or cement concrete).

The material is further evaluated in terms of its physical, mechanical and engineering properties. The standard test protocol for testing a conventional material may first be tried to evaluate the new material, but if it fails to characterize the material, appropriate testing equipment/scheme needs to be developed. The standard tests include (i) tests on the individual components (that is, tests on aggregates, asphalt binder or cement) and (ii) tests on the mix (that is, tests on asphalt mix or cement concrete). The tests may include assessment of physical (for example, moisture content, specific gravity, permeability, shape and size distribution of aggregates, volumetric proportion in a mix etc.), chemical (for example, chemical composition of cement, presence of organic material etc.) and engineering properties (for example, CBR value of soil, resilient modulus of unbound aggregates, unconfined compressive strength of cemented material, compressive strength of cement concrete etc.). For a newly proposed material, it may be needed to perform specialized tests such as, swelling potential (Motz and Geiseler 2001), reflectance, heat absorption, contamination possibility from built structure (Arias et al. 1998) etc. Based on the overall assessment, the suitability of the material is recommended for its possible use in subgrade, base, sub-base or surfacing layers.

Since a road is subjected to repetitions of traffic and weather variations during its service life, it becomes imperative to conduct experiments which reflect the long-term behavior and durability of such materials (for example, moisture susceptibility, rutting potential, fatigue behaviour etc.). Finally, one needs to monitor the performance of pavements constructed with these new materials.

### 15.3 Utilization of Wastes in Pavement Construction

Various wastes (some of these are shown in Fig. 15.1) may be utilized in various ways (for example, as partial replacement of soil, coarse aggregates or fines, or as additive/modifier to binder or as artificial aggregates etc.) in road construction (in surfacing, base/sub-base or subgrade level). Figure 15.2 presents a schematic diagram with various links indicating their possible usage. It may be mentioned that Fig. 15.2 is only a partial representation of the possibilities, it neither provides an exhaustive list of wastes/recycled materials which can possibly be used as road construction material, nor does it cover all types of application possibilities—the possibilities are, in fact, constantly expanding.

Whenever a new material is used as a replacement of existing material, a suitable proportion of the new material needs to be determined. This is obtained by gradually varying the proportion of the new material in the mix (say, in unbound granular material, asphalt mix or cement concrete) with respect to a desirable characteristic engineering/physical property. If the curve shows an increasing and then a decreasing trend, it may become easier to choose the optimal proportion as the peak value. Most of the time, mix design involves more complexities than satisfying only a single criterion. Various other desirable properties of the mix, for example, durability, available construction technology and cost considerations are also studied to decide a suitable proportion of mixing.

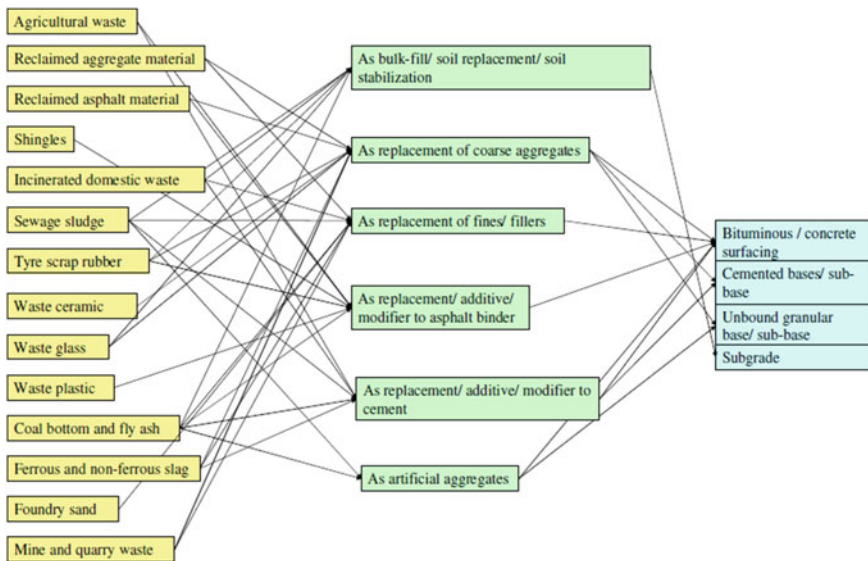

Fig. 15.2 Utilization scheme of various wastes in road construction

Finally, overall cost of procuring, processing, and haulage determines the feasibility of the proposed material for its use in road construction. The application possibilities of various recycled/waste material in road building (refer Fig. 15.2) are discussed in the following.

## 15.4 Agricultural Waste

The agricultural waste (relevant to road construction application) may consist of biomass from crop residues, food processing wastes (for example, epicarp of fruits removed during production of juices, coconut waste), wood lignin (Terrel 1980), swine manure (Fini et al. 2011) etc.

Bio-oil can be produced from biomass by fast thermo-chemical decomposition process (Fini et al. 2011). This bio-oil can be processed further to obtain bio-fuel, and subsequently it generates bitumen-like bio-binder as a by-product. Rice husk has been used as partial replacement of cement (CEMP 1999) and in soil stabilization (Basha et al. 2005). Studies suggest (Sundstrom et al. 1983; Terrel 1980) that lignin can be used as an extender to asphalt binder.

## 15.5 Construction and Demolition Wastes

Construction, renovation or demolition of various structures (for example, building, bridges, roads etc.) produces wastes. These wastes may include broken pieces of cement concrete, wood, ceramics (say, from tiles, basins), glasses (say, from window panes), asphalt shingles (say, from roofing), metals (say, from reinforcement, trusses, roofing), bricks, plastics etc. Depending on the source, the composition (and hence the properties) of these materials may vary. From these wastes, woods and metals can be separated and reused elsewhere. The broken pieces of cement concrete primarily consist of broken aggregates with hardened cement paste adhered to the aggregate surface. Aggregates can be recovered from unused concrete as well (Ferrari et al. 2014).

These may be referred as reclaimed/recycled concrete aggregates (RCA). Asphalt material can be recovered/reused from reclaimed asphalt pavement (RAP) and reclaimed asphalt shingles (RAS). These are discussed further in the following.

### 15.5.1 Reclaimed Aggregate Material

Studies show that RCA (or, reclaimed aggregate material (RAM), in generic terms) can be used as substitute for natural coarse aggregates in sub-base and base layers of pavement in bound (Ebrahimi et al. 2012; Gabr and Cameron 2012) or unbound form (Hansen 1992; Sherwood 1995; González and Martínez 2008; Thøgersen et al. 2013).

RCA can be used as a replacement of natural aggregates in cement concrete (Berndt 2009; Dam et al. 2012; Evangelistaa and de Britob 2013; Safiuddin et al. 2013; Shayan and Xu 2003) or, in asphalt concrete (Arabani et al. 2013; Parnavithana and Mohajerani 2006; Wong et al. 2007). Marshall stability, resilient modulus and stripping potential of asphalt mixes containing RCA are found to be comparable to asphalt mix with natural aggregates (Wong et al. 2007; Parnavithana and Mohajerani 2006).

Due to presence of cement mortar coating on aggregates, porosity of concrete containing RCA is generally found to be higher compared to natural aggregates (González and Martínez 2008). Similar observation was made by Parnavithana and Mohajerani (2006) on asphalt mixtures containing RCA.

Use of crushed bricks in cement concrete has been studied by various researchers (Debieb and Kenai 2009; Khaloo 1994). It is found that compressive and tensile strength of concrete with crushed brick are comparable to that of conventional concrete (Debieb and Kenai 2009; Khaloo 1994; Uddin et al. 2014). However, modulus of elasticity, shrinkage, creep and water absorption performance may be inferior compared to conventional concrete (Poon and Chan 2006). Feasibility of use of waste bricks in pavement sub-base (Arulrajah et al. 2012b) or brick powder as fillers (Chen et al. 2011) in asphalt mix have also been explored.

### ***15.5.2 Asphalt Recycling***

Substantial literature is available on the recommendations of various types of asphalt pavement recycling, namely in situ hot and cold recycling, central plant hot and cold recycling and full depth reclamation (Karlsson and Isacson 2006; McDaniel and Anderson 2001; McDaniel et al. 2000; Stroup-Gardiner 2011; Suleiman 2002). There are varied recommendations on the quantity of RAP (Al-Qadi et al. 2007) or RAS (Barry et al. 2013; Mauoin 2010; Foxlow et al. 2011) that may be utilized (Aravind and Das 2007b) in the recycled mix. Efforts are being made to maximize the quantity of RAP in the recycled mix, without compromising with the engineering property of the mix (Oliveira et al. 2013). RAP also has been used as replacement of aggregates in base/sub-base layers (Han 1993; Thøgersen et al. 2013; Wen and Wu 2011). Researches have conducted studies using RAP in cement concrete (Huang et al. 2005) as well.

## **15.6 Domestic Waste**

Incinerated municipal solid waste, tyre scrap rubber, waste ceramic (Huang et al. 2009; Feng et al. 2013; Stroup-Gardiner and Wattenberg-Komas 2013c), waste glass, waste plastic etc. are some of the domestic wastes which may have application potential in road construction. Some of these are discussed in the following.

### ***15.6.1 Incinerated Municipal Solid Waste***

A typical municipal solid waste (MSW) consists of fruit/vegetable peels, used containers (metal, glass), packaging materials, newspaper, clothing, food and garden wastes and does show significant variability depending on the source (Han 1993). Generally, MSW is incinerated and this incineration process produces energy and also results in considerable reduction in volume. The incinerated waste is obtained in the form of bottom ash and fly ash.

MSW bottom ash can be used as partial replacement of unbound granular material in base and sub-base layers (Forteza et al. 2004). Vizcarra et al. (2013) found that addition of MSW fly ash causes improvement of properties on weak and expansive soil. With partial replacement of conventional filler by incinerator ash in asphalt mix, researchers (Chen et al. 2008; Garrick and Chan 1993; Gress et al. 1992; Hassan 2005; Xue et al. 2009) found that volumetric, strength, fatigue, moisture sensitivity parameters are satisfactory, however the binder requirement becomes higher. Studies have been done using MSW fly ash for partial replacement of Portland cement (Goh et al. 2003; Stroup-Gardiner and Wattenberg-Komas 2013c). MSW ash may contain high concentration of water leachable constituent (Bagchi and Sopcich 1989; Chen et al. 2008; Eighmy et al. 1995; Flyhammara and Bendz 2006; Chen et al. 2008; Xue et al. 2009) and hence a detailed chemical analysis of MSW ash may be needed before using it for road construction.

### ***15.6.2 Sewage Sludge***

Use of incinerated sewage sludge as partial replacement of cement or as filler in asphalt mix has been reported in literature (Stroup-Gardiner and Wattenberg-Komas 2013c). Some researchers have proposed use of incinerated sewage sludge for stabilization of subgrade soil (Chen and Lin 2009; de Figueirêdo Lopes Lucena et al. 2013). Some researchers (Anh Tuan 2014; Mun 2007) reported satisfactory properties of cement concrete with artificial lightweight aggregates manufactured from incinerated sewage sludge.

### ***15.6.3 Tyre Scrap Rubber***

Waste rubber tyres, after their useful life, have been used for slope stability and drainage purpose in roads. Tyre chips can be used as filling material (Engstrom and Lamb 1994). The mechanical property of tyre chips is similar to wood, but it is non-biodegradable and may be difficult to compact (Han 1993).

Crumb rubber has been used as replacement of aggregates (known as dry process of mixing) in asphalt mix and as additive to asphalt binder (known as wet process of

mixing)(Buncher 1995, Huang et al. 2007b). Amount of rubber that can be utilized in dry process is generally more than that of wet process (Roberts et al. 1989). In dry process, crumb rubber is mixed with heated aggregates before adding asphalt binder. In wet process, crumb rubber (of size generally smaller than that of in dry process (Huang et al. 2007a)), along with other aromatic oil (if needed), is blended with asphalt at elevated temperature. This helps in uniform distribution of rubber particles in asphalt binder (Airey et al. 2002). Researchers also have attempted to use crumb rubber as replacement of aggregates in cement concrete mix (Liu 2013; Stroup-Gardiner and Wattenberg-Komas 2013g).

Dry mixed crumb rubber modified asphalt mix has been found to show improved performance in terms of resilient modulus, noise and fatigue life (Huang et al. 2007a; Sibal et al. 2000). Wet mixed crumb rubber modified asphalt mix has been found to show improved performance in terms of failure strain (Kim et al. 2007; Huang et al. 2007b), low temperature resistance (Huang et al. 2007a), rutting resistance (Fontes et al. 2010; Huang et al. 2007b) etc. The modified binder can be used as crack sealant and stress absorbing interlayer (Han 1993) and have been used as overlays on reflective cracking.

Leaching (Han 1993; Humphrey and Katz 2000), separation of rubber and asphalt binder (Kim et al. 2007; Shu and Huang 2014), emission during hot-mixing (Stroup-Gardiner and Wattenberg-Komas 2013g), recyclability (Han 1993) etc. are some of the issues identified by the researchers, specific to various types of mixes

#### **15.6.4 Waste Glass**

Domestic waste glass originates from used cans and containers those are discarded after use. High quality, color sorted and contamination free broken glasses are normally reused for making new glass products (Skumatz and Freeman 2007).

Crushed glass can be used for paving applications as compacted fill and in sub-base layers (Wartman et al. 2004). It shows low/negligible frost susceptibility (Henry and Morin 1997). Crushed glass, used as partial replacement of aggregates in base course, may show the rutting performance as comparable to that of the base course made with natural aggregates (Arnold et al. 2008).

Attempts have been made to use glass cullet as replacement to aggregates in asphalt mix and such mixes are known as glasphalt (Arnold et al. 2008). The surface of glass aggregates is smooth compared to a typical stone aggregates, but the glass aggregates have sharp edges (Huang et al. 2007a; Larsen 1989). Further, the glass aggregates do not contain any pores. Thus, glass aggregates do not absorb binder; consequently the optimum asphalt binder content is generally obtained as lower (Su and Chen 2002) compared to conventional asphalt mixes. However, this may lead to decreased bonding between aggregate and binder (Meyer et al. 2001). It is observed that with the increase of percentage of waste glass, stability value of asphalt mix may decrease (Su and Chen 2002), however, skid resistance and light reflection intensity improves (Su and Chen 2002), thereby increasing safety of roads in heavy rainfall areas.

### ***15.6.5 Waste Plastic***

Similar to tyre scrap rubber, attempts have also been made to add varieties of plastics (CEMP 1999) to asphalt mix using either wet or dry process. The asphalt mix with added waste plastic has been observed to show improvement in terms of fatigue, permanent deformation, bending strength, moisture resistivity etc. in various research studies (Behl et al. 2014; Huang et al. 2007a; Kalantar et al. 2012; Punith and Veeraragavan 2011). The type of waste plastic used and its variability affects the behaviour of the resultant mix (Kalantar et al. 2012). Studies have been also done using recycled plastics in concrete as replacement of aggregates (Liu et al. 2013).

## **15.7 Industrial Waste**

Boiler slag, coal bottom ash, coal fly ash, ferrous and non-ferrous slag, foundry sand, mine and quarry refuse, recycled asphalt pavement etc. are some of the industrial wastes with possible application potential in road construction. Some of these are discussed in the following.

### ***15.7.1 Coal Bottom Ash***

Coal bottom ash (CBA) is the ash generated at the bottom of the furnace due to coal burning. The particle size of CBA is coarser than coal fly ash (FHWA 2013). CBA can be dry or wet type (Han 1993). The dry CBA is generally black to grey in colour and sand-like particles in shape; the wet CBA is generally crystalline, angular and glassy after quenching in water hopper (Han 1993).

The CBA has been used as base/sub-base course material (Dawson and Bullen 1991) and as bulk fill material (FHWA 2013). Bottom ash blended with cementitious materials (for example, Portland cement, cement kiln dust, lime kiln dusts) may be used as form stabilized base courses (Stroup-Gardiner and Wattenberg-Komas 2013b). Due to low pH and salt content, bottom ash may corrode metallic structures in the vicinity (FHWA 2013). Studies suggest that asphalt concrete made up of bottom ash may show improved skid resistance and stripping potential (Majidzadeh et al. 1979; Shuler 1976), but rutting performance may be inferior (Majidzadeh et al. 1979).

### ***15.7.2 Coal Fly Ash***

Coal fly ash is fine particulate matter, generated during burning of coal and are generally captured by electrostatic precipitators/filter fabric collectors. Quality of fly



ash is affected by type of coal, degree of pulverization before burning, type of furnace, collector used and so on (Miller and Collins 1976).

Coal fly ash is used as an admixture to cement concrete or to make fly ash blended cement; thus fly ash replaces cement to some extent (Dam et al. 2012). Addition of fly ash used in cement concrete improves workability, alkali-aggregate reaction, sulphate resistance and reduces bleeding. It is also used as filling material for subgrade and other pavement layers. Fly ash has been used as mineral filler in asphalt concrete (Ali et al. 1996; Miller and Collins 1976). Fly ash (class F) has pozzolanic properties, it reacts with alkaline material (say lime) in presence of moisture and forms cementitious compound. Fly ash with lime has been used as lightly bound base/sub-base structure (Arora and Aydilek 2005; Mulder 1996; Wen et al. 2011). As the surface area of fly ash particles is more, it may act as extender of asphalt binder (Ali et al. 1996). There is a possibility to derive synthetic aggregates from coal fly ash (Stroup-Gardiner and Wattenberg-Komas 2013b).

### ***15.7.3 Ferrous and Non-ferrous Slag***

Various ferrous and non-ferrous slag (for example, copper slag (Taha et al. 2004; Kumar 2013), zinc slag, phosphorus slag (Qian et al. 2013) etc.) materials have been used as replacement of aggregates in pavement base/sub-base (Han 1993; Motz and Geiseler 2001). Particle size of the slag, composition, hardness etc. depends on the process unit and mode of cooling. Ground slag has been used as filler material in asphalt mix and also used in blended cement (Dam et al. 2012; Griffiths and Krstulovich Jr 2002). Lime and fly ash mixture is sometimes used as binding material (Bagampadde et al. 1999). Researchers found that asphalt mix with steel slag shows improved performances in terms of rutting, noise reduction, resistance to abrasion, low temperature cracking, surface friction etc. (Motz and Geiseler 2001; Hunt and Boyle 2000; Huang et al. 2007a; Wu et al. 2007). Volumetric expansion, possibilities of leaching, low abrasive resistance, cost of haulage (because of high density) etc. are some of the concerns (FHWA 2013; Griffiths and Krstulovich Jr 2002; Huang et al. 2007a; Lind et al. 2001; Motz and Geiseler 2001; Stroup-Gardiner and Wattenberg-Komas 2013a).

### ***15.7.4 Foundry Sand***

Foundry sands are generally uniform sized sand particles. The size and gradation depends on type of metal being cast. Researchers have investigated the use of waste foundry sand in cement concrete (Etxeberria et al. 2010; Singh and Siddique 2012). Guney et al. (2006) reported that addition of lime increases the strength and California Bearing Ratio (CBR) of unbound sub-base with foundry sand added.

Studies indicate that waste foundry sand can be used as partial replacement of fines in asphalt mix (Kleven et al. 2000; Javed et al. 1994).

### ***15.7.5 Mine and Quarry Refuse***

Mine and quarry refuse are used as replacement of aggregates, fines, cement substitute or for stabilization of base/sub-base (Stroup-Gardiner and Wattenberg-Komas 2013d). Such wastes include colliery spoil (Sherwood 1995), unburnt coal refuse (Wenger and Schmidt 1970), wastes from boron mining (Kütük-Sert and Kütük 2013), wastes from stone quarry (Akbulut and Gurer 2007; Zou et al. 2013), slate waste (Dawson et al. 1995); marble dust (Chandra and Choudhary 2013; Karaşahin and Terzi 2007) and so on.

## **15.8 Pavement Design Considerations**

The engineering characterization of the proposed material (asphalt mix, cement concrete, soil, cemented or unbound granular material) provides information on its strength and expected performance. This information can be used as design input. That is, the same design principles (empirical or mechanistic-empirical) can be used with the revised numerical values of the material properties of the proposed new material/mix (Colbert et al. 2013; Ebrahimi et al. 2012; Aravind and Das 2007a). However, one can argue that the performance of the new material may be different than the pavements built with conventional material, and the same empirical design equations or calibration constants may not necessarily be valid. In that case, one needs to gather performance data of the roads built with the new materials and calibrate the design equations afresh.

Pavement design often involves managing conflicting parameters. For example, an asphalt mix with high stiffness may indicate relatively lower fatigue performance. Given a choice, the mix is to be so designed that the maximum economy in the structural design of the pavement is achieved. Further, when reclaimed material is used (say, as partial replacement of conventional material), there would be saving in the material consumption, but if the properties (say, stiffness and/or fatigue life) are found inferior than the conventional mix, the estimated design thickness may increase. Both these factors determine the overall savings towards the material cost (Aravind and Das 2007a).

Again, not only the initial material cost of construction of the new pavement, but also the total life cycle cost including the road user cost and the agency cost (including the cost of maintenance and rehabilitation) need to be considered (Irfan et al. 2012; Li and Madanat 2002). This determines the overall success of the proposed new material in the road construction.

## 15.9 Closure

Possible use of various waste products (from agricultural, construction and demolition, domestic and industrial sources) in road construction has been discussed in this chapter. The list is definitely not exhaustive (Krishnaswamy and Das 2012). There are many other waste materials with a possible application potential in highway construction, for example, andesite waste (Uzun and Terzi 2012), bag-house fines (FHWA 2013), e-waste plastics (Colbert et al. 2013), excavation waste (Arulrajah et al. 2012a), cement kiln dust (Taha 2003; Taha et al. 2004), lime kiln dust (Griffiths and Krstulovich Jr 2002), oil shale waste, wastes from phosphate and aluminum industry (CEMP 1999; Misra et al. 2004), waste lime from glass and detergent industry (Do et al. 2008), sludge from paper industry, spray drier fly ash, silica fume (CEMP 1999), sulphate waste (CEMP 1999; Stroup-Gardiner and Wattenberg-Komas 2013a), used engine oil (Hamad et al. 2003; Sherwood 1995) and so on. The list is ever expanding.

Further, it is quite possible that there are many other such waste products which are locally available (or produced), but have not been explored well in terms of their possible usage in road construction. There is also a possibility that combination of materials (obtained as different waste products from different sources) can be developed as a new material worthy for road construction. For example, laboratory studies with soil-fly ash-copper slag (Havanagi et al. 2007), copper slag-fly ash-dolomite (Shahu et al. 2013), steel slag-blast furnace slag (Guo and Shi 2013), RAP-RCA blend (Arulrajah et al. 2014) etc. are so far encouraging.

Some of the present issues/considerations with the use of waste materials in road construction are: (i) need of detailed environmental evaluation (Bloomquist et al. 1993; Roth and Eklund 2003), (ii) scalability from laboratory results to field applications, (iii) workers' health and safety, (iv) quantity available and overall economy involved in using a proposed material in road construction vis-à-vis conventional material, (v) understanding the long term performance of such material, (vi) re-recyclability potential (Peploe and Dawson 2006), (vii) chances of gradual degradation of material (viii) legalization needed for use of such materials (ix) variability in material properties (FHWA 2013; Han 1993; Kalantar et al. 2012) (x) development of new protocol for material characterization (if required), reproducibility of test results and quality control (FHWA 2013) etc.

Large number review/synthesis documents and research studies on comparative evaluation amongst various waste materials (for possible use of road construction) are available (Ahmed 1991; Dawson et al. 1995; CEMP 1999; Evangelistaa and de Britob 2013; FHWA 2013; Han 1993; Hill et al. 2001; Huang et al. 2007a; Kandhal 1992; Schimmoller et al. 2000; Sherwood 1995; Stroup-Gardiner and Wattenberg-Komas 2013a, b, c, d, e, f, g, h; Taha et al. 2004). It is expected that there would be enhanced use of such unconventional materials in road construction in future. This is a contribution towards sustainability.

The performance data collected on the roads thus built would enrich our experience to build even better roads in future.

**Acknowledgment** The authors are thankful to Ms. Ambika Kuity, a Ph.D. student in the Department of Civil Engineering, IIT Kanpur for her help in reformatting the paper as per Springer book format guidelines.

## References

- Airey, G. D., Singleton, T. M., & Collop, A. C. (2002). Properties of polymer modified bitumen after rubber-bitumen interaction. *Journal of Materials in Civil Engineering*, 14, 244–354.
- Akbulut, H., & Gurer, C. (2007). Use of aggregates produced from marble quarry waste in asphalt pavements. *Building and Environment*, 42(5), 1921–1930.
- Ahmed, I. (1991). *Use of waste materials in highway construction*. Final Report, Department of Civil Engineering, Purdue University, FHWA/IN/JHRP-91/03.
- Al-Qadi, I., Elseifi, M., & Carpenter, S. H. (2007). *Reclaimed asphalt pavement—a literature review*, Research Report FHWA-ICT-07-001.
- Ali, N., Chan, J. S., Simms, S., et al. (1996). Mechanistic evaluation of fly ash asphalt concrete mixtures. *Journal of Materials in Civil Engineering*, 8(1), 19–25.
- Anh Tuan, B., Tesfamariam, M.G., Chen, Y., Hwang, C., Lin, K., & Young, M. (2014). Production of lightweight aggregate from sewage sludge and reservoir sediment for high-flowing concrete. *Journal of Construction Engineering and Management*, 140(5), 04014005.
- Apul, D. S. (2004). Contributions to predicting contaminant leaching from secondary materials used in roads. *Ph.D. thesis*, Department of Civil Engineering, University of New Hampshire.
- Arabani, M., Nejad, F. M., & Azarhoosh, A. R. (2013). Laboratory evaluation of recycled waste concrete into asphalt mixtures. *International Journal of Pavement Engineering*, 14(6), 531–539.
- Aravind, K., & Das, A. (2004). *Industrial waste in highway construction*. <http://home.iitk.ac.in/~adas/article07.pdf>.
- Aravind, K., & Das, A. (2007a). Pavement design with central plant hot-mix recycled asphalt mixes. *Construction and Building Materials*, 21(5), 928–936.
- Aravind, K., & Das, A. (2007b). Preliminary constituent proportioning for central plant hotmix asphalt. *Journal of Materials in Civil Engineering*, 19(9), 740–745.
- Arias, M., Nuñez, A., Barral, M. T., et al. (1998). Pollution potential of copper mine spoil used for road making. *The Science of the Total Environment*, 221, 111–116.
- Arnold, G., Werkemeister, S., & Alabaster, D. (2008). *The effect of adding recycled glass on the performance of base-course aggregate*. NZ Transport Agency Research Report, p. 351.
- Arora, S., & Adydilek, A. H., (2005). Class F fly-ash-amended soils as highway baseMaterials. *Journal of Materials in Civil Engineering*, 17(6), 640–649.
- Arulrajah, A., Piratheepan, J., & Disfani, M. M. (2014). Reclaimed asphalt pavement and recycled concrete aggregate blends in pavement subbases: Laboratory and field evaluation. *Journal of Materials in Civil Engineering*, 26(2), 349–357.
- Ashmawy, A., McDonald, R., & Carreon, D. et al. (2006). *Stabilization of marginal soils using recycled materials*. Final Report, Florida Department of Transportation, Report # BD-544-4.
- Arulrajah, A., Ali, Y. M. M., Piratheepan, J., et al. (2012a). Geotechnical properties of waste excavation rock in pavement sub-base applications. *Journal of Materials in Civil Engineering ASCE*, 24(7), 924–932.
- Arulrajah, A., Piratheepan, J., Bo, M. W., et al. (2012b). Geotechnical characteristics of recycled crushed brick blends for pavement sub-base applications. *Canadian Geotechnical Journal*, 49(7), 796–811.
- Bagampadde, U., Wahhab, H. I. A.-A., & Aiban, S. A. (1999). Optimization of steel slag aggregates for bituminous mixes in Saudi Arab. *Journal of Materials in Civil Engineering*, 11(1), 30–35.
- Bagchi, A., & Sopcich, D. (1989). Characterization of MSW incinerator ash. *Journal of Environmental Engineering*, 115(2), 447–452.

- Barry, K., Daniel, J. S., Foxlow, J., et al. (2013). An evaluation of reclaimed asphalt shingles in hot mix asphalt by varying sources and quantity of reclaimed asphalt shingles. *Road Materials and Pavement Design*, 15(2), 259–271.
- Basha, E. A., Hashim, R., Mahmud, H. B., & Muntohar, A. S. (2005). Stabilization of residual soil with rice husk ash and cement. *Construction and Building Materials*, 9(6), 448–453.
- Behl, A., Sharma, G., & Kumar, G. (2014). A sustainable approach: Utilization of waste PVC in asphaltting of roads. *Construction and Building Materials*, 54, 113–117.
- Berndt, M. L. (2009). Properties of sustainable concrete containing fly ash slag and recycled concrete aggregate. *Construction and Building Materials*, 23, 2606–2613.
- Bloomquist, D., Diamond, G., & Oden, M. et al. (1993). *Engineering and environmental aspects of recycled materials for highway construction*. FHWA-RD-93-088, Western Research Institute, Laramie.
- Buncher, M. S. (1995). Evaluation the effects of the wet and dry processes for including crumb rubber modifier in hot mix asphalt. *Ph.D. Dissertation*, Department of Civil Engineering, Auburn University.
- CEMP-ET Engineer Technical Manual. (1999). *Use of waste materials in pavement construction*. No. ETL 1110-3-503, Department of the Army, U.S. Army Corps of Engineers, Washington, D.C.
- Chandra, S., & Choudhary, R. (2013). Performance characteristics of bituminous concrete with industrial wastes as filler. *Journal of Materials in Civil Engineering*, 25(11), 1666–1673.
- Chen, J., Chu, P., Chang, J., et al. (2008). Engineering and environmental characterization of municipal solid waste bottom ash as an aggregate substitute utilized for asphalt concrete. *Journal of Materials in Civil Engineering*, 20(6), 432–439.
- Chen, M., Lin, J., Wu, S., et al. (2011). Utilization of recycled brick powder as alternative filler in asphalt mixture. *Construction and Building Materials*, 25(4), 1532–1536.
- Chen, L., & Lin, D. F. (2009). Stabilization treatment of soft subgrade soil by sewage sludge ash and cement. *Journal of Hazard Materials*, 162(1), 321–327.
- Chimenos, J. M., Segarra, M., Fernandez, M. A., et al. (1999). Characterization of the bottom ash in municipal solid waste incinerator. *Journal of Hazardous Materials*, 64, 211–222.
- Colbert, B. W., Diab, A., & You, Z. (2013). Using M-E PDG to study the effectiveness of electronic waste materials modification on asphalt pavements design thickness. *International Journal of Pavement Research and Technology*, 6(4), 319–326.
- Dam, T. V., Taylor, P., & Fick, G. et al. (2012). *Sustainable concrete pavements: A manual of practice*. Institute for Transportation, Iowa State University.
- Dawson, A. R., & Bullen, F. (1991). Furnace bottom ash: Its engineering properties and its use as sub-base material. *Proceedings of Institute of Civil Engineers, Part 1*(90), 993–1009.
- Dawson, A. R., Elliot, R. C., & Rowe, G. M. et al. (1995). Assessment of suitability of some industrial by-products for use in pavement bases in the United Kingdom. *Transportation Research Record*, 1486, TRB, National Research Council, TRB, pp. 114–123.
- de Figueirêdo Lopes Lucena, L. C., Thomé Juca, J. F., & Soares, J. B. et al. (2013). Potential uses of sewage sludge in highway construction. *Journal of Materials in Civil Engineering*, 26(9), 04014051.
- Debieb, F., & Kenai, S. (2009). The use of coarse and coarse and fine crushed bricks as aggregate in concrete. *Construction and Building Materials*, 22(5), 886–893.
- Department for Environment, Food and Rural Affairs (DEFRA). (2013a). Retrieved January 31, 2013, from <http://archive.defra.gov.uk/evidence/statistics/environment/waste/kf/wrkf09.htm>.
- Department for Environment, Food and Rural Affairs (DEFRA). (2013b). Retrieved January 31, 2013, from <http://www.defra.gov.uk/statistics/environment/waste/wrfg09-condem/>.
- Do, S. H., Mum, P. H., & Keun, R. S. (2008). A study on engineering characteristics of asphalt concrete using filler with recycled waste lime. *Waste Management*, 28, 191–199.
- Ebrahimi, A., Kootstra, B. R., Edil, T. B., et al. (2012). Practical approach for designing flexible pavements using recycled roadway materials as base course. *Road Materials and Pavement Design*, 13(4), 731–748.

- Eighmy, T. T., Crimi, D., & Zhang, X. et al. (1995). Influence of void change, cracking, and bitumen aging on diffusional leaching behavior of pavement monoliths constructed with MSW combustion bottom ash. *Transportation Research Record*, 1486, TRB, National Research Council, Washington, D. C., pp. 42–48.
- Eldin, N. N. (2002). Road construction: Materials and methods. *Journal of Environmental Engineering*, 128(5), 423–430.
- Engstrom, G. M., & Lamb, R. (1994). *Using shredded waste tires as lightweight fill material for road subgrades*. Report # MN/RD–94/10, Minnesota Department of Transportation.
- Evangelistaa, L., & de Britob, J. (2013). Concrete with fine recycled aggregates: A review. *European Journal of Environmental and Civil Engineering*, 18(2), 129–172.
- Exteberria, M., Pacheco, C., Meneses, J. M., et al. (2010). Properties of concrete using metallurgical industrial by-products as aggregates. *Construction and Building Materials*, 24(9), 1594–1600.
- Federal Highway Administration (FHWA). (2013). *User guidelines for waste and byproduct materials in pavement construction*. Retrieved January 15, 2013, from <http://www.fhwa.dot.gov/publications/research/infrastructure/structures/97148/cbabs1.cfm>.
- Feng, D., Yi, J., & Wang, D. (2013). Performance and thermal evaluation of incorporating waste ceramic aggregates in wearing layer of asphalt pavement. *Journal of Materials in Civil Engineering*, 25(7), 857–863.
- Ferrari, G., Miyamoto, M., & Ferrari, A. (2014). New sustainable technology for recycling returned concrete. *Construction and Building Materials*, 67(part C), 363–359.
- Fini, E., Kalberer, E., Shahbazi, A., et al. (2011). Chemical characterization of biobinder from swine manure: Sustainable modifier for asphalt binder. *Journal of Materials in Civil Engineering*, 23, 1506–1513.
- Flyhammara, P., & Bendz, D. (2006). Leaching of different elements from subbase layers of alternative aggregates in pavement constructions. *Journal of Hazardous Materials*, 137(1), 603–611.
- Fontes, L. P. T. L., Trichês, G., Pais, J. C., & Pereira, P. A. A. (2010). Evaluating permanent deformation in asphalt rubber mixtures. *Construction and Building Materials*, 24(7), 1193–1200.
- Forteza, R., Far, M., Seguí, C., et al. (2004). Characterization of bottom ash in municipal solid waste incinerators for its use in road base. *Waste Management*, 24(9), 899–909.
- Foxlow, J. J., Daniel, J. S., & Swamy, A. K. (2011). RAP or RAS? The differences in performance of HMA containing reclaimed asphalt pavement and reclaimed asphalt shingles. *Journal of the Association of Asphalt Paving Technologists*, 80, 347–376.
- Gabr, A., & Cameron, D. (2012). Properties of recycled concrete aggregate for unbound pavement construction. *Journal of Materials in Civil Engineering*, 24(6), 754–776.
- Garrick, N. W., & Chan, K. L. (1993). Evaluation of domestic incineration ash for use as aggregate in asphalt concrete. *Transportation Research Record*, 1418, TRB, National Research Council, Washington D. C., pp. 30–34.
- Goh, C. C., Show, K. Y., & Cheong, H. K. (2003). Municipal solid waste fly ash as a blended cement material. *Journal of Materials in Civil Engineering*, 15(6), 513–523.
- González-Fonteboa, B., & Martínez-Abella, F. (2008). Concretes with aggregates from demolition waste and silica fume materials and mechanical properties. *Building and Environment*, 43(4), 429–437.
- Gress, D., Zhang, X., & Tarr, S. et al. (1992). Physical and environmental properties of asphalt-amended bottom ash. *Transportation Research Record*, No. 1345, TRB, National Research Council, pp. 10–18.
- Griffiths, C. T., & Krstulovich, J. M. Jr. (2002). *Utilization of Recycled Materials in Illinois Highway Construction*. Physical Research Report No. 142, Illinois Department of Transportation.
- Guney, Y., Aydılek, A. H., & Demirkan, M. M. (2006). Geoenvironmental behavior of foundry sand amended mixtures for highway subbases. *Waste Management*, 26(9), 932–945.
- Guo, X., & Shi, H. (2013). Utilization of steel slag powder as a combined admixture with ground granulated blast-furnace slag in cement based materials. *Journal of Materials in Civil Engineering*, 25(12), 1990–1993.



- Hamad, B. S., Rteil, A. A., & El-Fadel, M. (2003). Effect of used engine oil on properties of fresh and hardened concrete. *Construction and Building Materials*, 17, 311–318.
- Han, C. (1993). *Waste products in highway construction*. Final Report, Minnesota Local Road Research Board
- Hansen, T. C. (1992). *Recycling of demolished concrete and masonry*. RIELM Report No. 6, E&FN Spon, UK.
- Hassan, H. F. (2005). Recycling of municipal solid waste incinerator ash in hot-mix asphalt concrete. *Construction and Building Materials*, 19(2), 91–98.
- Havanagi, V. G., Mathur, S., & Prasad, P. S. et al. (2007). Feasibility of copper slag-fly ash-soil mix as a road construction material. *Transportation Research Record*, 1989(2), TRB, National Research Council, pp. 13–20.
- Henry, K. S., & Morin, S. H. (1997). Frost susceptibility of crushed glass used as construction aggregate. *Journal of Cold Regions Engineering*, 11(4), 326–333.
- Hill, A. R., Dawson, A. R., & Mundy, M. (2001). Utilization of aggregate materials in road construction and bulk fill. *Resources, Conservation & Recycling*, 32, 305–320.
- Hill, A. R. (2004). Leaching of alternative pavement materials. *Ph.D. thesis* submitted to School of Civil Engineering, University of Nottingham. Retrieved June 15, 2013, from <http://www.nottingham.ac.uk/~evzncpe/Theses/HillPhDthesis.pdf>.
- Huang, Y., Bird, R. N., & Heidrich, O. (2007a). A review of the use of recycled solid waste materials in asphalt pavements. Resources. *Conservation and Recycling*, 52, 58–73
- Huang, B., Mohammad, L. N., Graves, P. S., & Abadie, C. (2007b). Louisiana experience with crumb rubber-modified hot-mix asphalt pavement. *Transportation Research Record*, 1789, TRB, National Research Council, Washington, D.C., pp. 1–13.
- Huang, B., Dong, Q., & Burdette, E. G. (2009). Laboratory evaluation of incorporating waste ceramic materials into Portland cement and asphaltic concrete. *Construction and Building Materials*, 29(12), 3451–3456.
- Huang, B., Shu, X., & Li, G. (2005). Laboratory investigation of portland cement concrete containing recycled asphalt pavements. *Cement and Concrete Research*, 35, 2008–2013.
- Humphrey, D. N., & Katz, L. E. (2000). Water-quality effects of tire shreds placed above the water table. *Transportation Research Record*, 1714, TRB, National Research Council, Washington, D.C., pp. 18–24.
- Hunt, L., & Boyle, G. E. (2000). *Steel slags in hot mix asphalt concrete*. Final Report, State Research Project, Salem, Oregon
- Irfan, M., Khurshid, M. B., Bai, Q., et al. (2012). Establishing optimal project-level strategies for pavement maintenance and rehabilitation—A framework and case study. *Engineering Optimization*, 44(5), 565–589.
- Javed, S., Lovell, C. W., Wood, L. E. et al. (1994). Waste foundry sand in asphalt concrete. *Transportation Research Record*, 1437, TRB, National Research Council, Washington, D.C., pp. 27–34.
- Khaloo, A. R. (1994). Properties of concrete using crushed clinker brick as coarse aggregate. *ACI Materials Journal*, 91(4), 401–407.
- Kalantar, Z. N., Karim, M. R., & Mahrez, A. (2012). A review of using waste and virgin polymer in pavement. *Construction and Building Materials*, 33, 55–62.
- Kandhal, P. S. (1992). *Waste materials in hot-mix asphalt—an overview* (pp. 92–106). Report: NCAT.
- Karavaşin, M., & Terzi, S. (2007). Evaluation of marble waste dust in the mixture of asphaltic concrete. *Construction and Building Materials*, 21(3), 616–620.
- Karlsson, R., & Isacson, U. (2006). Material-related aspects of asphalt recycling—state-of-the-art. *Journal of Materials in Civil Engineering*, 18(1), 81–92.
- Kim, S., Loh, S., & Zhai, H. et al. (2007). Advanced characterization of crumb rubber-modified asphalts, using protocols developed for complex binders. *Transportation Research Record*, No. 1767, TRB, National Research Council, Washington D.C., pp. 15–24.
- Kleven, J. R., Edil, T. B., & Benson, C. H. (2000) Evaluation of excess foundry system sands for use as sub base material. *Transportation Research Record*, No. 1714, TRB, National Research Council, Washington, D.C., pp. 40–48.

- Krishnaswamy, A., & Das, A. (2012). *Possible use of some waste materials in road construction*. Masterbuilder, October, pp. 44–48.
- Kumar, B. (2013). Properties of pavement quality concrete and dry lean concrete with copper slag as fine aggregates. *International Journal of Pavement Engineering*, 14(8), 746–751.
- Kütük-Sert, T., & Kütük, S. (2013). Physical and Marshall properties of borogypsum used as filler aggregate in asphalt concrete. *Journal of Materials in Civil Engineering*, 25(2), 266–273.
- Larsen, D. A. (1989). *Feasibility of utilizing waste glass in pavements*. Connecticut Department of Transportation, Report no. 343-21-89-6.
- Li, Y., & Madanat, S. (2002). A steady-state solution for the optimal pavement resurfacing problem. *Transportation Research Part A: Policy and Practice*, 36(2), 525–535.
- Lind, B. B., Fällman, A. M., & Larsson, L. B. (2001). Environmental impact of ferrochrome slag in road construction. *Waste Management*, 21, 255–264.
- Lindsay, B. J., & Logan, T. J. (2005). Agricultural reuse of foundry sand. *Journal of Residuals Science & Technology*, 2, 3–12.
- Liu, R. (2013). *Recycled tires as coarse aggregates in concrete pavement mixtures*. Report no. CDOT-2013-10, DTD Applied Research and Innovation Branch, Colorado Department of Transportation.
- Liu, F., Yan, Y., Li, L., Lan, C., & Chen, G. (2013). Performance of recycled plastic-based concrete. *Journal of Materials in Civil Engineering*. doi:10.1061/(ASCE)MT.1943-5533.0000989.
- Majidzadeh, K., El-Mitiny, R. N., & Bokowski, G. (1979). *Power plant bottom ash in black base and bituminous surfacing*. Materials Division, USA: Federal Highway Administration.
- Malhotra, V. M. (2002). Sustainable development and concrete technology. *Concrete International*, 24(7), 35–40.
- Mauoin, G. W. (2010). *Investigation of the use of tear-off shingles in asphalt concrete*. Virginia Transportation Research Council, VTRC 10-R23. Retrieved June 9, 2013, from [http://www.virginiadot.org/vtrc/main/online\\_reports/pdf/10-r23.pdf](http://www.virginiadot.org/vtrc/main/online_reports/pdf/10-r23.pdf).
- McDaniel, R., & Anderson, R. M. (2001). *Recommended use of reclaimed asphalt pavement in the Superpave mix design method: technician's manual*. NCHRP Rep. No. 452, TRB, National Research Council, Washington, D.C.
- McDaniel, R., Soleymani, H., & Anderson, R. M. et al. (2000). *Recommended use of reclaimed asphalt pavement in the Superpave mix design method*. NCHRP Web Document 30, TRB, National Research Council, Washington, D.C.
- Misra, A. K., Mathur, R., & Goel, P. et al. (2004). Use of phosphogypsum—An industrial by-product in stabilisation of black cotton soils. *Highway Research Bulletin*, 70, 65–75 (Indian Roads Congress).
- Meyer, C., Egosi, N., & Andela, C. (2001). Concrete with waste glass as aggregate in recycling and re-use of Glass Cullet. In R. K. Dhir, T. D. Dyer, & M. C. Limbachiya (Eds.), *Proceedings of the International Symposium Concrete Technology*, Unit of ASCE and University of Dundee.
- Miller, R. H., & Collins, R. J. (1976). *Waste materials as potential replacements for highway aggregates*. NCHRP Report 166, Transportation Research Board.
- Motz, H., & Geiseler, J. (2001). Products of steel slags an opportunity to save natural resources. *Waste Management*, 21, 285–293.
- Mroueh, U. M., & Wahlström, M. (2002). By products and recycled materials in earth construction in Finland – an assessment of applicability. *Resources, Conservation and Recycling*, 35, 117–129.
- Mulder, E. (1996). A mixture of fly ashes as road base construction material. *Waste Management*, 16(1–3), 15–20.
- Mun, K. J. (2007). Development and tests of lightweight aggregate using sewage sludge for nonstructural concrete. *Construction and Building Materials*, 21, 1583–1588.
- Nelson, P. O., Huber, W. C., & Neil, N. (2000). *Primer environmental impact of construction and repair materials on surface and ground waters*. Final report, NCHRP REPORT 443, Transportation Research Board, National Research Council, National Academy Press, Washington, D.C.



- Oliveira, J. R. M., Silva, H. M. R. D., & Jesus, C. M. G. (2013). Pushing the asphalt recycling to the limit. *International Journal of Pavement Research and Technology*, 6(2), 109–116.
- Paranavithana, S., & Mohajerani, A. (2006). Effects of recycled concrete aggregates on properties of asphalt concrete. *Resources, Conservation and Recycling*, 48(1), 1–12.
- Peplow, R., & Dawson, A. (2006). Environmental impact of industrial byproducts in road construction—A literature review. *Land Transport New Zealand Research Report*, 308, 38.
- Poon, C. S., & Chan, D. (2006). Paving blocks made with recycled concrete aggregate and crushed clay brick. *Construction and Building Materials*, 20(8), 569–577.
- Punith, V. S., & Veeragavan, A. (2011). Behavior of reclaimed polyethylene modified asphalt cement for paving purposes. *Journal of Materials in Civil Engineering*, 23(6), 833–845.
- Qian, G., Bai, S., Ju, S., et al. (2013). Laboratory evaluation on recycling waste phosphorus slag as the mineral filler in hot-mix asphalt. *Journal of Materials in Civil Engineering*, 25(7), 846–850.
- Roberts, F. L., Kandhal, P. S., & Brown, E. R. et al. (1989). *Investigation and evaluation of ground tire rubber in hot mix asphalt*. National Center for Asphalt Technology Auburn University, Alabama NCAT Report 89-03.
- Roth, L., & Eklund, M. (2003). Environmental evaluation of reuse of by-products as road construction materials in Sweden. *Waste Management*, 23, 107–116.
- Shahu, J. T., Patel, S., & Senapati, A. (2013). Engineering properties of copper slag–fly ash–dolomite mix and its utilization in the base course of flexible pavements. *Journal of Materials in Civil Engineering*, 25(12), 1871–1879.
- Safuddin, M., Alengaram, U. J., Rahman, M. M., Salam, M. A., & Jumaat, M. Z. (2013). Use of recycled concrete aggregate in concrete: A review. *Journal of Civil Engineering and Management*, 19(6), 796–810.
- Schimmoller, V. E., Holtz, K., & Eighmy, T. T. et al. (2000). *Recycled materials in European highway environments: Uses, technologies, and policies*. Office of International Programs Office of Policy, Federal Highway Administration U.S. Department of Transportation.
- Sibal, A., Das, A., & Pandey, B. B. (2000). Flexural fatigue characteristics of asphalt concrete with crumb rubber. *International Journal of Pavement Engineering*, 1(2), 119–132.
- Singh, G., & Siddique, R. (2012). Abrasion resistance and strength properties of concrete containing waste foundry sand (WFS). *Construction and Building Materials*, 28(1), 421–426.
- Su, N., & Chen, J. S. (2002). Engineering properties of asphalt concrete made with recycled glass. *Resources, Conservation and Recycling*, 35(4), 259–274.
- Shayan, A., & Xu, A. (2003). Performance and properties of structural concrete made with recycled concrete aggregates. *ACI Materials Journal*, 100(5), 371–380.
- Sherwood, P. T. (1995). *Alternative materials in road construction*. London: Thomas Telford.
- Shu, X., & Huang, B. (2014). *Recycling of waste tire rubber in asphalt and portland cement concrete: An overview* <http://dx.doi.org/10.1016/j.conbuildmat.2013.11.027>.
- Shuler, T. S. (1976). *The effects of bottom ash upon bituminous sand mixtures*. Publication FHWA/IN/JHRP-76/11. Joint Highway Research Project, Indiana Department of Transportation and Purdue University, West Lafayette, Indiana.
- Skumatz, L. A., & Freeman, J. (2007). What to do with these piles? *Resource Recycling*, 26, 35–39.
- Stroup-Gardiner, M. (2011). *Recycling and reclamation of asphalt pavements using in-place methods—A synthesis of highway practice*. NCHRP Synthesis report 421, Transportation Research Board, Washington, D.C.
- Stroup-Gardiner, M., & Wattenberg-Komas, T. (2013a). *Recycled materials and byproducts in highway applications*, Vol. 1: Summary Report. A Synthesis of Highway Practice, NCHRP Synthesis 435, Transportation Research Board, Washington, D.C.
- Stroup-Gardiner, M., & Wattenberg-Komas, T. (2013b). *Recycled materials and byproducts in highway applications*, Vol. 2: Coal Combustion Byproducts. A Synthesis of Highway Practice, NCHRP Synthesis 435, Transportation Research Board, Washington, D.C.
- Stroup-Gardiner, M., & Wattenberg-Komas, T. (2013c). *Recycled materials and byproducts in highway applications*, Vol. 3: Non-Coal Combustion Byproducts. A Synthesis of Highway Practice, NCHRP Synthesis 435, Transportation Research Board, Washington, D.C.

- Stroup-Gardiner, M., & Wattenberg-Komas, T. (2013d). *Recycled materials and byproducts in highway applications*, Vol. 4: Mineral and Quarry Byproducts. A Synthesis of Highway Practice, NCHRP Synthesis 435, Transportation Research Board, Washington, D.C.
- Stroup-Gardiner, M., & Wattenberg-Komas, T. (2013e). *Recycled materials and byproducts in highway applications*, Vol. 5: Slag Byproducts. A Synthesis of Highway Practice, NCHRP Synthesis 435, Transportation Research Board, Washington, D.C.
- Stroup-Gardiner, M., & Wattenberg-Komas, T. (2013f). *Recycled materials and byproducts in highway applications*, Vol. 6: Reclaimed Asphalt Pavement, Recycled Concrete Aggregate, and Construction Demolition Waste. A Synthesis of Highway Practice, NCHRP Synthesis 435, Transportation Research Board, Washington, D.C.
- Stroup-Gardiner, M., & Wattenberg-Komas, T. (2013g). *Recycled materials and byproducts in highway applications*, Vol. 7: Scrap Tire Byproducts. A Synthesis of Highway Practice, NCHRP Synthesis 435, Transportation Research Board, Washington, D.C.
- Stroup-Gardiner, M., & Wattenberg-Komas, T. (2013h). *Recycled materials and byproducts in highway applications*, Vol. 8: Manufacturing and Construction Byproducts. A Synthesis of Highway Practice, NCHRP Synthesis 435, Transportation Research Board, Washington, D.C.
- Suleiman, N. (2002). *A state-of-the-art review of cold in-place recycling of asphalt pavements in the northern plains region*. Final Report Submitted to the North Dakota Department of Transportation, Department of Civil Engineering, University of North Dakota.
- Sundstrom, D. W., Klei, H. E., & Stephens, J. E. (1983). *The addition of lignin from gasohol plants to asphalts*. Project 80-3, Department of Civil Engineering, University of Connecticut. Retrieved December 20, 2012, from [http://www.cti.uconn.edu/pdfs/jhr83-149\\_80-3.pdf](http://www.cti.uconn.edu/pdfs/jhr83-149_80-3.pdf).
- Taha, R. (2003). Evaluation of cement kiln dust-stabilised reclaimed asphalt pavement aggregate systems in road bases. *Transportation Research Record*, No. 1819, Transportation Research Board, National Research Council, Washington D.C., pp. 11–17.
- Taha, R., Al-Rawas, A., Al-Jabri, K., et al. (2004). An overview of waste materials recycling in the Sultanate of Oman. *Resources, Conservation and Recycling*, 41(4), 293–306.
- Terrel, R. L. (1980). *Evaluation of wood lignin as a substitute or extender of asphalt*. FHWA Report Number FHWA-RD-80-125.
- Thøgersen, F., Gregoire, C., Stryk, J., et al. (2013). Recycling of road materials into new unbound road layers—Main practice in selected European countries. *Road Materials and Pavement Design*, 14(2), 438–444.
- Uddin, M. T., Hasnat, A., Awal, M. A., & Bosunia, S. Z. (2014). Recycling of brick aggregate concrete as coarse aggregate. *Journal of Materials in Civil Engineering*, doi:10.1061/(ASCE)MT.1943-5533.0001043.
- Uzun, I., & Terzi, S. (2012). Evaluation of andesite waste as mineral filler in asphaltic concrete mixture. *Construction and Building Materials*, 31, 284–288.
- Vizcarra, G. O. C., Casagrand, M. D. T., & Motta, L. M. G. (2013). Applicability of municipal solid waste incineration ash on base layers of pavements. *Journal of Materials in Civil Engineering*, 26(6), 06014005.
- Wartman, J., Grubb, D., & Nasim, A. (2004). Select engineering characteristics of crushed glass. *Journal of Materials in Civil Engineering*, 16(6), 526–539.
- Wen, H., Baugh, J., & Edil, T. et al. (2011). Cementitious high-carbon fly ash used to stabilize recycled pavement materials as base course. *Transportation Research Record*, TRB, National Research Council, Washington, D.C., 2204, pp. 110–113.
- Wen, H., & Wu, M. (2011). *Evaluation of high percentage recycled asphalt pavement as base materials*. Final report, TNW2011-15, Submitted by Department of Civil and Environmental Engineering, University of Washington, Transportation Northwest and Washington State Department of Transportation.
- Wenger, M. E., & Schmidt, G. H. (1970). *Anthracite refuse as an aggregate in bituminous concrete*. Pennsylvania Department of Transportation, Research Project No. 70-8
- Wong, Y. D., Sun, D. D., & Lai, D. (2007). Value-added utilization of recycled concrete in hot-mix asphalt. *Waste Management*, 27(2), 294–301.

- Wu, S., Xue, Y., & Ye, Q. (2007). Utilization of steel slag as aggregates for stone mastic asphalt (SMA) mixtures. *Building and Environment*, 42, 2580–2585.
- Xue, Y., Hou, H., Zhu, S., et al. (2009). Utilization of municipal waste incineration ash in stone matrix asphalt mixture: Pavement performance and environmental impact. *Construction and Building Materials*, 23, 989–996.
- Yoon, S., Balunaini, U., Yildirim, I., et al. (2009). Construction of an embankment with a fly and bottom ash mixture: Field performance study. *Journal of Materials in Civil Engineering*, 21(6), 271–278.
- Zou, G., Xu, J., & Wu, C. (2013). Feasibility study of using quarry waste for pavement application and its optimization. *International Journal of Pavement Research and Technology*, 6(3), 175–183.

# Chapter 16

## Cool Pavements

K. Wayne Lee and Steven Kohm

**Abstract** This chapter deals with Urban Heat Island (UHI) mitigation and cool pavements. It starts with a brief introduction on UHI and various mitigation approaches including cool pavements. The urban cityscape is covered with man-made materials that absorb the sun's energy. Dark colored roads and roofs have replaced surface area which was once predominantly vegetated lands. Impervious pavements cover a large amount of urban surface area, typically 30–45 %. For these reasons summertime ambient temperatures in cities are typically warmer than those of rural areas. Heat islands lead to increased air conditioning use which puts a strain on a city's energy grid. To supply this extra wattage, power plants must work harder and as a result emit more carbon. Therefore, the heat island effect contributes to environmental problems including air quality and climate change. One solution to this problem is the implementation of cool pavement technologies in areas of where less stringent structural requirements exist, such as parking lots and low volume roads. Cool pavements are a class of materials that exhibit enhanced cooling by means of increased reflectivity or increased convection. This chapter correlates heat island effect to climate change as well as outlining the different cool pavement technologies which may help to mitigate climate change effects.

### 16.1 Background

During the summer the average metropolis experiences increased ambient temperatures in the afternoon and night compared to rural areas. On a hot, sunny summer day, the sun can heat dry, exposed urban surfaces, such as roofs and

---

K.W. Lee (✉)

Department of Civil and Environmental Engineering, The University of Rhode Island, Kingston, USA

e-mail: leew@egr.uri.edu

S. Kohm

Office of Solid Waste and Emergency Response, Environmental Protection Agency, Arlington, VA, USA

© Springer-Verlag Berlin Heidelberg 2014

K. Gopalakrishnan et al. (eds.), *Climate Change, Energy, Sustainability and Pavements*, Green Energy and Technology, DOI 10.1007/978-3-662-44719-2\_16

pavements, to temperatures 50–90 °F (27–50 °C) hotter than the air, while shaded or moist surfaces—often in more rural surroundings—remain close to air temperatures (Berdaahl and Bretz 1997). The annual mean air temperature of a city with 1 million people or more can be 1.8–5.4 °F (1–3 °C) warmer than its surroundings (Akbari 2005). On a clear, calm night, however, the temperature difference can be as much as 22 °F (12 °C).

To compensate for these increased temperatures, people utilize air conditioning units which consume huge amounts of electricity. In developed countries where concerted action is being taken on UHIs, the main concern is on the large increase in power consumption in urban areas to cool down buildings, with additional air-conditioners or a heavier usage of existing air-conditioners (Shahmohamadi et al. 2011). Issues related to the potential impact of global warming on air-conditioning energy use was also conducted in the hot climate of the United Arab Emirates, and it was reported that global warming is likely to increase the energy used for cooling buildings by 23.5 % (Radhi 2009). In order to cover the surplus wattage demand municipal power plants must pump out more energy, burn more fossil fuel, and emit more carbon dioxide. One reason for this increased temperature in urban regions is the composition of the surface area. Land which was once with vegetation is now inhabited by humans and blanketed with infrastructure. Industrial activities often cause environmental problems such as poor air quality, local temperature increase and excessive noise levels (Zakaria and Yang 2008). Cityscapes are made up of darkly colored materials capable of absorbing the sun's energy. Asphalt paves our streets, and typically asphalt shingles covers roofs in developed countries. During summer months these dark surfaces contribute to increased ambient temperatures in the late afternoon and at night (Fig. 16.1).

By increasing the albedo of urban areas in a global climate model and running a simulation for 80 years ahead, Akbari et al. (2012) estimated a CO<sub>2</sub> offset of between 130 and 150 billion tonnes—equivalent to taking every car in the world off the road. Increasing the albedo of the urban areas and human settlements (hence increasing the albedo of Earth as a whole) by increasing the reflectivity of artificial urban surfaces (rooftops, pavements), was based on proven technologies that have been used for centuries with no known negative effect (Goodman 1999).

UHI could create larger demand for cooling which strains the energy grid and raises emission outputs from fossil fuel based power plants. Increasing the cooling

**Fig. 16.1** Urban heat-island profile (NASA 1999)

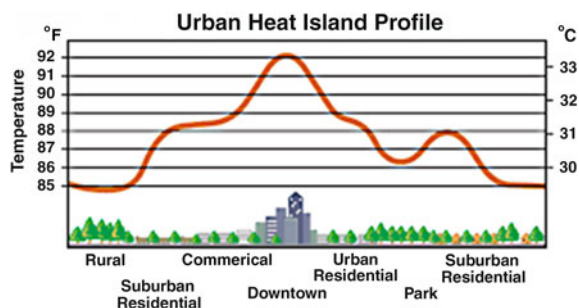

of paved areas in cities can serve as a transitive means of reducing CO<sub>2</sub> emissions and mitigating climate change.

More specifically, rethinking approaches to parking lot and local road design is one method to potentially mitigate carbon emissions. Generally speaking, some parking lots may be over-designed for the low volume of traffic they experience. The use of specially engineered paving materials can reduce the amount of heat absorbed by parking lots and in turn decrease air temperatures, energy use, and Greenhouse Gas (GHG) emissions.

This chapter correlates Urban Heat Island (UHI) effects with US emissions to provide a better understanding of seasonal urban emissions. Also, an overview of different cool pavement technologies is included as means of climate change mitigation.

## 16.2 Urban Heat Island Effect and Albedo

UHI effect describes the lingering increased ambient temperatures in cities during warmer months. Perhaps the best way to begin describing the UHI effect is to discuss the thermodynamic relationship between a material's surface and the sun's energy. The sun imparts energy onto the earth in the form of electromagnetic radiation. Once this radiation is filtered through the atmosphere it reaches the earth's surface. From there, objects absorb a percentage of that energy and store it usually in the form of heat. The energy that cannot be absorbed is reflected. The most well-known type of reflective surface is the cool roof. Solar reflective cars or cool cars reflect more sunlight than dark cars, reducing the amount of heat that is transmitted into the car's interior. Therefore, it helps decreasing the need for air conditioning, fuel consumption, and emissions of GHG and urban air pollutants (LBNL 2011).

This ability of a material to reflect or absorb the sun's light is measured in a dimensionless parameter known as albedo. Theoretically, albedo can range from 0 for very dark energy absorptive surfaces to 1 for lightly colored reflective surfaces. No objects can absorb or reflect 100 % of the sun's energy radiated upon them, therefore, an albedo of 0 or 1 is never seen on an earthly object. Fresh asphalt concrete has an albedo of 0.04 because of the dark black bituminous material used to bind aggregates (Akbari 2000). Albedo is a parameter that can be indirectly computed using a device known as a pyranometer. This device measures electromagnetic radiation in units of energy per square area. Albedo is the ratio of total reflected electromagnetic radiation to electromagnetic radiation delivered at the time of incident (Levinson et al. 2009). Fundamental properties can be found from Fig. 16.2 (Kaloush 2010).

As previously mentioned, fresh asphalt concrete has an albedo of 0.04 meaning it absorbs a large amount of the sun's radiation compared to the amount it reflects. Typical parking lots have about 4 inches of asphalt concrete covering compacted earth (AI 1981). Therefore, the capacity to store heat in a sprawling asphalt parking lot is huge. During the hottest hours of the day, asphalt concrete stores most of the

- Albedo,  $\alpha$
- Emissivity,  $\epsilon$
- Convection Coefficient,  $h$
- Thermal Conductivity,  $k$
- Specific Heat,  $C$
- Density,  $\rho$
- Thermal Diffusivity,  $\alpha, \kappa$
- Porosity,  $\phi$

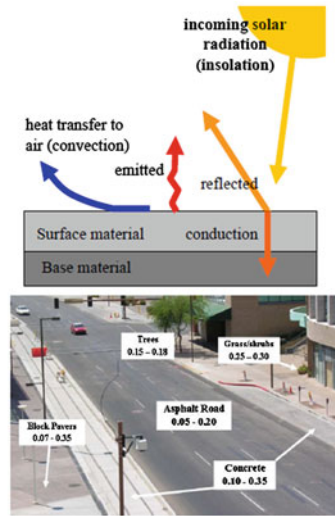

Fig. 16.2 Fundamental properties of heat island (Kaloush 2010)

sun’s energy in the form of heat. During cooler times, the asphalt concrete releases that heat to keep in equilibrium with the surrounding air. This idea of equilibrium is consistent with the zeroth law of thermodynamics. Since dark surfaces, such as asphalt concrete, are abundant in cities there is more heat stored in the pavement, and has the potential to be released. This forces ambient temperatures to be elevated at times during the day when solar radiation is less significant. This phenomenon is known as the Urban Heat Island (UHI) effect. Rural areas have a greater percentage of their surface covered in vegetation and highly reflective materials. This is why heat islands are less pronounced or non-existent in these regions. After a sunny summer day city temperatures can be up to 5 °C (8 °F), higher than rural areas (Akbari 2000).

Dark surfaces like asphalt pavement have several consequences associated with them. One such consequence is elevated temperature of stormwater runoff. Hotter runoff can be detrimental to aquatic life and ecosystems. For example, asphalt pavement with a surface temperature of 38 °C (100 °F) is able to heat rainwater from 21 °C (70 °F) to 35 °C (95 °F) (James 2002). Hotter runoff can also alter the fate and transport of urban contaminants by affecting hazardous compound aqueous solubility and rate of volatilization (EPA 2009). UHI effect increases ambient temperatures creating an increased demand for cooling. This increased demand for cooling can amount to a 5–10 % increase in peak electricity (Akbari 2005; Santamouris et al. 2001). One estimate shows that the temperature increase from the heat island effect in Los Angeles can account for up to 1.5 GW of energy (Akbari 2000). This increase causes additional emissions from municipal power plants. Therefore, the UHI effect contributes to problems with air quality including smog formation. However, the biggest consequence of dark pavements and UHI may be their contribution to climate change.

### 16.3 Heat Island and Climate Change

Climate change is a pressing topic, it makes headlines daily ranging from legislative initiatives to scientific studies. The anthropogenic release of gas, such as CO<sub>2</sub>, is repeatedly cited as the reason climate change is occurring (EPA 2010). Since there are many gases besides CO<sub>2</sub> that contribute to climate change they are ranked in terms of equivalents of CO<sub>2</sub>. For example, 1 part methane [CH<sub>4</sub>] converts to 21 CO<sub>2</sub> equivalents. In the US the predominant source of CO<sub>2</sub> equivalent emissions stems from fossil fuel combustion. Fossil fuel combustion totaled 85.1 % or 5,573 Tg of CO<sub>2</sub> equivalents in 2008 (Fig. 16.3) (EPA 2010).

Out of fossil fuel combustion’s 5,573 equivalents, 2,636 are used for electricity generation (Fig. 16.4). This yields about 36 % of total US GHG emissions.

Electricity generated through the burning of fossil fuels is the number one emitter of GHG in the US. It is also noticed (Fig. 16.4) that coal is the fuel that comprises the greatest percent of electricity generated. Unfortunately, coal also has the greatest potential for carbon emissions per unit power created. In order to judge the potential for emissions reductions it may be noted that one estimate shows in Los Angeles (LA) UHI effects may account for up to 1.5 GW of energy (Akbari 2000). Through examining the mix of fossil fuels burned to create these superfluous

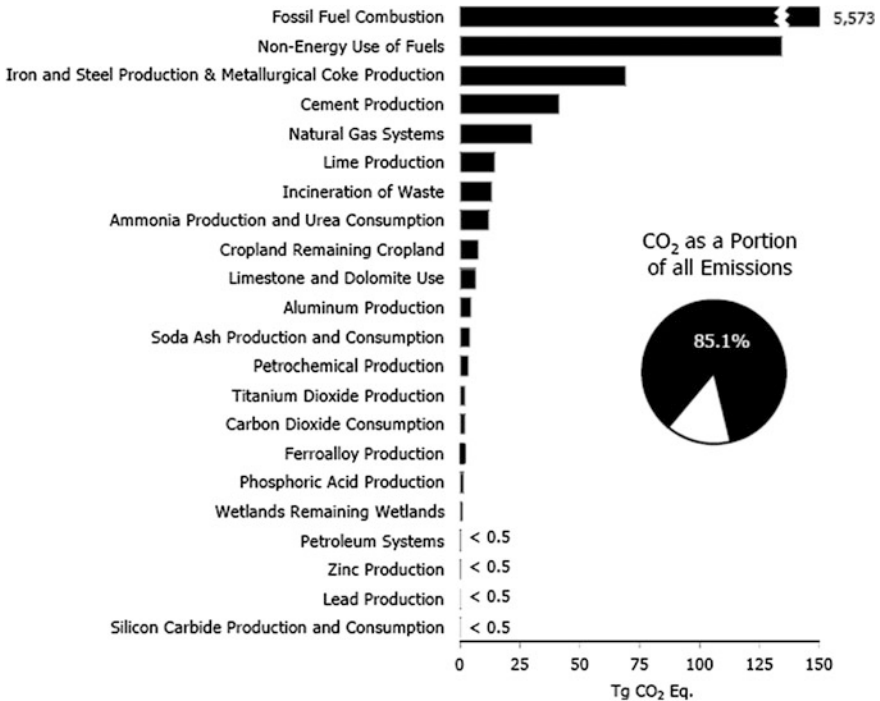

Fig. 16.3 Sources of US CO<sub>2</sub> equivalent emissions in 2008 (EPA 2010)



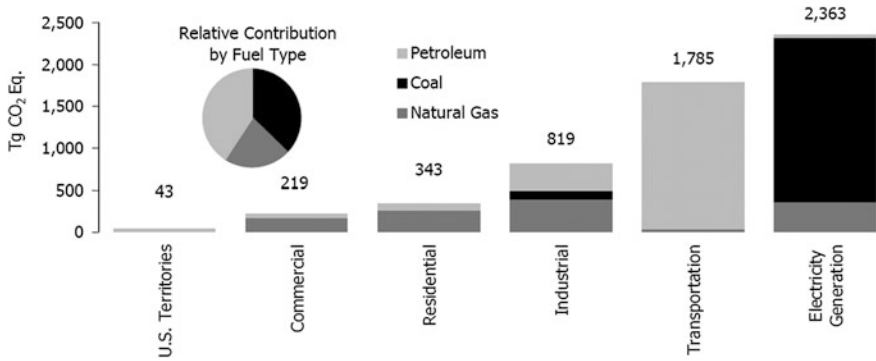

Fig. 16.4 US 2008 fossil fuel combustion breakdown (EPA 2010)

1.5 GW of energy the potential for emissions reductions can be achieved if the UHI effect is mitigated in LA. Figure 16.4 shows the correlation between fossil fuel type and CO<sub>2</sub> emitted.

It is clear that targeting reductions in electricity consumption from cooling stands to significantly reduce anthropogenic gas emissions. Electricity reductions can further decrease total US emissions because coal comprises such a large percentage of fuel used to generate the electricity (Fig. 16.5). Therefore, reducing cooling electricity peaks can assist in the mitigation of climate change effects for future generations especially at coal based power plants.

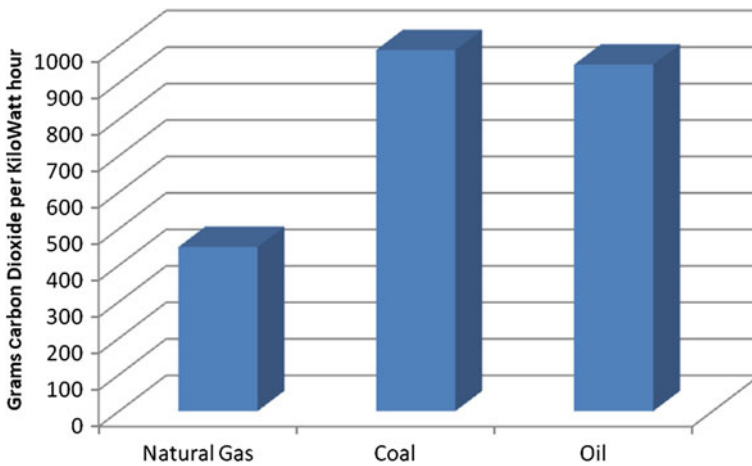

Fig. 16.5 Average emissions dependent on fuel type (UK DECC 2009)

**Table 16.1** Parking lot coverage in US cities (Wong 2005)

City	Paved area (%)	Parking coverage (%)
Salt Lake City	36	11.6
Sacramento	45	12.4
Chicago	37	15.2
Houston	29	15.9

Note Parking coverage indicates the percentage of all city areas

## 16.4 Urban Surfaces

Percentages of urban surfaces covered by pavement can be identified through Geography Information System (GIS) techniques. In a typical US city paved surfaces make up 30–45 % of the total area (Wong 2005). That amount can be further dissected to determine the percentage of the area covered by parking lots through spatial GIS and aerial satellite photograph. Table 16.1 shows the percentage of four major US cities covered by parking areas. This data were extrapolated from several figures in the EPA's *Reducing Urban Heat Islands: Compendium of Strategies* document (Wong 2005).

Judging from Table 16.1, about 10–15 % of most major cities are covered by parking areas. Compared to roads, parking lots experience less traffic volume and lower speeds which may allow relaxation of design requirements. When designing parking areas, the primary concern is cost. There are an estimated 253.1 million registered passenger vehicles in the US and as the population increases this number will continue to grow (BTS 2011). Parking lots will need to be larger and more numerous which will exacerbate UHI effects. To address these problems, new cool pavement materials should be implemented. To review, new parking lot materials might be beneficial because of the following reasons:

1. Parking comprises a growing amount of urban/suburban surface area
2. Parking areas may have lower design requirements compared to roads
3. Parking areas have potential for pollution reduction in:
  - GHG—UHI effect
  - Contaminated runoff—runoff with increased temperature and contaminants.

## 16.5 Cool Pavement Technologies

Cool pavements are a class of pavement technologies which can be used to mitigate UHI effects. They reduce heat being released later in the day and at night by two main principals; increased reflectivity and increased convection. Some cool pavement technologies utilize both principals. By increasing the reflectivity of pavements, less of the sun's energy can be absorbed leading to less heat being available for later

release. Convection is the main heat transfer principal that allows energy to move between a solid and gas (Kreith 1976). Therefore, energy moving from hot pavements to ambient air is controlled by temperature gradients and convection. Allowing more convection to take place at a faster rate will effectively allow pavements to reach equilibrium with cooler ambient air sooner. Additional pavement convection is produced by increasing contact of the pavement with surrounding air. This can be accomplished by making pavements permeable (Li 2012; Li et al. 2013; Kaloush 2010). In this scenario more air comes in contact with a greater pavement surface area and in turn cools faster. Cool pavement technologies are discussed in the following section based on the thermodynamic principle they employ to cool.

### ***16.5.1 Increased Reflectivity***

#### **16.5.1.1 Modified Asphalt Pavements**

As asphalt ages it typically becomes more reflective due to the wear of the black bitumen over time. If the asphalt is mixed with lightly colored aggregate it will be able to reflect 15–20 % of sunlight compared to the 4 % in its newly laid state (Wong 2005). Another modified asphalt option is to add a pigmentation step into the asphalt mix process. This allows for the creation of colored pavements. Some successes have been reported with this process, e.g., a children's park plaza in Seoul, Korea where pavements were modified with ultramarine blue color (Lee et al. 1988). The effects of modified asphalt on UHI effect are currently minor and more effective options should be considered especially for parking lots (Liu et al. 2010; Adrian and Jobanputra 2005; Fang et al. 2012). This will allow for more substantial emission reduction.

#### **16.5.1.2 Modified Portland Cement Concrete**

Without any modifications, Portland cement concrete is a moderately reflective surface with Albedo value of 0.10–0.35. Typical mixtures of concrete containing aggregate, grey cement and water can reflect up to 40 % of the sun's light. However, by using lightly colored aggregate and white cement, reflectivity can be increased up to 70 % (Wong 2005). The cement industry in the US is another large producer of CO<sub>2</sub> emissions, about 41.1 Tg CO<sub>2</sub> equivalent in 2008 (Fig. 16.3) (EPA 2010). These emissions originate from the kiln firing in cement production which requires temperatures of almost 3,000 °F (PCA 2010).

White cement is very similar to grey cements with a number of different manufacturing steps involved. Unfortunately, one of these differences is an increased kiln temperature (LePiver 2010). Increased kiln temperature leads to higher fuel consumption and more emissions. By using white cement, emissions that are saved through UHI cooling may be reallocated to the manufacturing process emissions.

This could be moving around the CO<sub>2</sub> emissions rather than reducing them. To determine if the emission reductions from white cement outweigh the extra emissions from the manufacturing, more detail about specific mix designs and thermodynamics must be researched.

### **16.5.1.3 Lightly Colored Chip Seals**

Chip seals could be created by binding a layer of lightly colored aggregate to the top of asphalt concrete. This technology is typically used to resurface low volume roads. One type of chip seal is micro surfacing. This refers to binding a thin layer of lightly colored aggregates to the surface of asphalt pavements with materials different from concrete cements. Polymers, emulsion, and resins are all considered as means of binding a thin layer of aggregates to raise reflectivity (Wong 2005).

### **16.5.1.4 Whitetopping and Ultra Thin Whitetopping**

Whitetopping is accomplished by placing a layer of concrete on top of asphalt pavements. This raises the reflectivity of a surface from about 4 % to approximately 40 % (Wong 2005). The thickness of this top concrete layers differs by technology name. Whitetopping usually refers to four or more inches of concrete laid upon the asphalt and ultra-thin whitetopping refers to two to four inches (Chango 2009).

### **16.5.1.5 Resin Based Pavements**

Resin based pavements are a flexible pavement that utilize a tree based resin to bind aggregate in lieu of traditional petroleum based products. The reflectivity of these pavements is directly dependent on the aggregate used because the resin is clear. An initial resin layer is applied to the base layer, then the mixture of aggregate and resin is placed on top. Next, a final layer of resin is sprayed on to ensure cohesion of materials. Resin based pavements can be aesthetically pleasing for walkways, bike paths, and parking lots (Fig. 16.6). It may be noted that resin based pavements have served as long as regular asphalt pavements (Lee et al. 1988).

## ***16.5.2 Increased Convection***

### **16.5.2.1 Porous Asphalt Pavements**

Porous asphalt cools through an increased surface area in contact with the ambient air. If properly designed, this system allows for contaminant removal and is recharging of the groundwater. Porous asphalt is composed of an open graded mix

**Fig. 16.6** Resin based pavement path (McCormack 2010)



of larger aggregates bound together with bituminous material. This layer is laid on a one inch choker course of crushed stone. Below the choker layer is several feet of crushed stone that serves as a reservoir for infiltrating runoff. A minimal slope is provided to allow for infiltration of storm water. These systems are typically designed with respect to a historically high water table and greater than the 100 year storm event (DCCD 2009). This prevents flooding and contaminants from being smeared through the soil profile during large storm events. Also, ample drainage helps protect the pavement from freeze-thaw cycles during winter months. It is possible for pores of the asphalt concrete to become clogged with sand, salt, and other debris. Therefore, it is important annual maintenance steps are executed to ensure runoff continues to drain.

### 16.5.2.2 Pervious Concrete Pavements

Pervious concrete cools and works under a very similar system as porous asphalt. The top layer is an open graded aggregate bound with cement paste (Fig. 16.7). Water to cement ratios for porous concrete range from 0.27 to 0.30 (NRMCA 2009). Below the concrete layer there is a layer of crushed stone to serve as a reservoir as rain water waits to drain into the in situ vadose zone. There is typically no choker course in this system because the concrete can be laid directly upon the large crushed stone. Flow rates for pervious concrete can reach up to 5 gal/ft<sup>2</sup>/min for certain mixes (NRMCA 2009).

The drawbacks of these pavements are increased costs and problems with winter maintenance. Many of these technologies do not take well to the plowing of snow and application of de-icing salts. Deicing salts can clog permeable lots and plows can destroy the top layer of pavements.

**Fig. 16.7** Pervious concrete  
(Source Gaia engineering)



### 16.5.2.3 Solar Energy Harvesting

The concept of harvesting solar energy from asphalt pavement is enticing because it offers a way to collect solar energy by utilizing an existing infrastructure. Thus, there is a need to investigate novel methods for solar energy harvesting and conversion with potential economic efficiency substantially beyond that of current technology.

A practical method to harvest solar energy would be embedding highly conductive water pipes underneath asphalt pavements, and taking advantage of their untapped solar potential (Chen et al. 2009; Lee and Correia 2010; Mallick et al. 2012). Once heated, this water can be used as-is to heat buildings or can be passed through a thermoelectric generator to produce electricity. Since the temperature would be already about 60 °C (140 °F), it may require a little electricity to produce vapor initially. However, if the vapor makes turbines spin to generate electricity, it will become a self-sufficient system (Kwon et al. 2012). It should be noted that the temperature of asphalt pavement will be lower after solar energy will heat the water. Consequently, the asphalt pavement can last longer, and it can be one of sustainable pavement maintenance techniques.

## 16.5.3 Increased Reflectivity and Convection

### 16.5.3.1 Grass Paving

Grass paving is a unique technique that can help to mitigate the UHI. A specialized grid of plastic material is placed upon engineered fill. The spaces in between the grid are filled with grass seed (Fig. 16.8). The system is highly reflective and also allows for increased convection due to permeability. Some systems claim compressive strengths of up to 40 MPa (5,731 psi) (ISI 2010).

**Fig. 16.8** Grass pave reinforcement grid (Source Invisible structures Inc. 2010)



### 16.6 Summary

EPA published a compendium of strategies on reducing UHI. It has been adapted by the authors as shown in Table 16.2 containing information regarding characteristics such as degree of UHI reduction impact, relative cost, relative durability, etc. (Lee et al. 2010).

**Table 16.2** Pavement technologies summary modified from EPA’s *Reducing Urban Heat Islands: Compendium of Strategies*

Technology	Heat island contribution	Approx. cost, \$/ft <sup>2</sup>	Life, years	Cost/benefits	Weakness
Conventional asphalt concrete	High	\$0.10–\$1.50	7–20	Costly	Heat island effect
Conventional PCC concrete	Medium	\$0.30–\$4.50	15–35	Costly	–
Modified asphalt pavement	Medium	\$0.10–\$1.50	7–20	–	–
Modified PCC	Medium	\$0.30–\$4.50	15–36	Costly	White cement emission
Chip seals	Low	\$0.10–\$0.15	2–8	Resurfacing ability	Service life
Ultra thin whitetopping	Low	\$1.50–\$6.50	10–15	Resurfacing ability	Debris covering reflectivity
Resin based pavements	Low	\$2.50–\$3.50	6–10	Improved aesthetics	Solvents used
Porous asphalt	Medium	\$2.00–\$2.50	7–10	Storm water control	Costly
Porous concrete	Low	\$5.00–\$6.25	15–20	Storm water control	Costly
Grass paving	Low	\$1.50–\$5.75	>10	Storm water control	Winter conditions

Note The base year for the cost was 2005

## 16.7 Conclusions and Recommendations

Vast areas of dark pavements in urban areas are one contributing factor to increased ambient temperatures from the UHI effect. This is especially significant during summer months. The increased ambient temperatures create a larger demand for cooling and electricity from municipal power plants. The generation of more electricity from these plants produces more GHG. Therefore, addressing urban heat island effects has the potential to reduce GHG emissions.

Scanning urban areas shows parking lots comprise about 10–15 % of the total surface area in many US cities. Also, design requirements for parking lots are not as stringent because they experience less traffic volume at lower speeds. Targeting parking lots with cool pavement technologies can be used as a transitive means of reducing GHG emissions. As the effective service lives of parking lots expire, cool pavement options could be implemented. Then, various cool pavement technologies can be expanded into other infrastructures like roadways to mitigate UHI effects and to reduce environmental problems including air quality and climate change.

## References

- Adrian, W., & Jobanputra, R. (2005). Influence of pavement reflectance on lighting for parking lots. PCA R&D Serial No. 2458.
- Akbari, H. (2005). Energy saving potentials and air quality benefits of urban heat island mitigation (PDF) (19 pp, 251 K). Berkeley: Lawrence Berkeley National Laboratory.
- Akbari, H. (2000). *Heat Island Group*. Lawrence Berkeley National Laboratories, Web. Retrieved 15 Oct, 2009, from <http://eetd.lbl.gov/HeatIsland/>
- Akbari, H., Matthews, H. D., & Seto, D. (2012). Geo-engineering cities using white roofs and pavements—the long-term effect of increasing the albedo of urban areas. *Environmental Research Letters*
- Asphalt Institute (AI). (1981). Full-depth asphalt pavements for parking lots, service stations and driveways. *Information Series*.
- Berdahl P., & Bretz, S. (1997). Preliminary survey of the solar reflectance of cool roofing materials. *Energy and Buildings*, 25, 149–158.
- Bureau of Transportation Statistics (BTS). (2011). Number of U.S. aircraft, vehicles, vessels, and other conveyances. *Bureau of Transportation Statistics*. Web. Retrieved May 8, 2010, from [http://www.bts.gov/publications/national\\_transportation\\_statistics/html/](http://www.bts.gov/publications/national_transportation_statistics/html/)
- Chango, H. (2009). Evaluation and implementation of ultra-thin white-topping as a rehabilitation technique. MS Thesis, University of Rhode Island.
- Chen, B., Bhowmick, S., & Mallick, R. B. (2009). A laboratory study on heat reduction of the heat island effect of asphalt pavements (pp. 209–247). Civil and Environmental Engineering, Worcester Polytechnic Institute and University of Massachusetts, Dartmouth.
- Dauphin County Conservation District (DCCD) (2010). *Porous Asphalt BMP*. Web. Retrieved May 8, 2010, from <http://www.dauphincd.org/swm/BMPfactsheets/Porous%20Asphalt%20fact%20sheet.pdf>
- Environmental Protection Agency (EPA). (2009). *Heat island effect*. Web. Retrieved 15 October, 2009, from <http://www.epa.gov/heatislands/index.htm>
- EPA (2010). Inventory of U.S. Greenhouse gas emissions and sinks: 1990–2008. Washington DC.



- Fang, C., Yu, R., Zhang, Y., Hu, J., Zhang, M., & Mi, X. (2012). Combined modification of asphalt with polyethylene packaging waste and organophilic montmorillonite. *Polymer Testing*, 31(2), 276–281 (Elsevier).
- Goodman, S. (1999). Urban Climatology and air quality. National Aeronautics and Space Administration (NASA).
- Invisible Structures Inc. (ISI). (2010). *Grass permeable paver*. Web. Retrieved 8 May, 2010, from <http://www.invisiblestructures.com/grasspave2.html>
- James, W. (2002). Green roads: research into permeable pavers. *Stormwater*, 3(2), 40–48.
- Kaloush, K. (2010). Pavements and the urban heat island effect. EPA's Cool Pavements Webcast, Arizona State University.
- Kreith, F. (1976). *Principles of heat transfer* (pp. 309–405, 3rd ed.). New York: Dun-Donnelley.
- Kwon, S., Hong, H., Lee, K. W., Yang, S., & Park, K. (2012). *A study on highway energy harvesting*. Final Report to Korean Expressway Corporation.
- Lawrence Berkeley National Laboratory (LBNL). (2011). Cool Cars. Heat Island Group.
- Lee, K. W., & Correia, A. (2010). *Investigation of novel methods to harvest solar energy from asphalt pavements*. A Research Report to Korean Institute of Construction Technology. Kingston, RI: University of Rhode Island.
- Lee, K. W., Kim, J. W., & Kim, D. W. (1988). Development of color pavement in Korea. *ASCE Journal of Transportation Engineering*, III(3), 292–302.
- Lee, K. W., Craver, V., Kohm, S., & Chango, H. (2010). *Proceedings of the Green Streets and Highways*, American Society of Civil Engineers (ASCE).
- LePiver, G. (2010). Burners for white cement kilns: Calcia Cruas (France). *Fives Pillard*, n.d. Web. Retrieved May 8, 2010, from [http://www.fivesgroup.com/fivespillard/en/Articles/Documents/CimentBlanc\\_GB.pdf](http://www.fivesgroup.com/fivespillard/en/Articles/Documents/CimentBlanc_GB.pdf)
- Levinson, R., Akbari, H., Pomerantz, M., Gupta, S. (2009). Solar access of residential rooftops in four California cities. *Solar Energy*, 83(12), 2120–2135.
- Li, H. (2012). Evaluation of cool pavement strategies for mitigating heat island and improving outdoor thermal environment. *Dissertation*, University of California at Davis.
- Li, H., Harvey, J., Holland, T., & Kayhanjan. (2013). The use of reflective and permeable pavements as a potential practice for heat island mitigation and stormwater management. *Environmental Research Letters*, 8, 015023.
- Liu, G., Kai, Q., Ye, R. (2010). Heat reflectivity properties of asphalt mixtures modified with Nano A/SBS-II: prediction of temperature in asphalt pavement, integrated transportation systems: green, intelligent, reliable, American society of civil engineers (ASCE).
- Mallick, R., Carelli, J., Albano, L., Bhowmick, S., & Veeraragavan, A. (2012). Evaluation of the potential of harvesting heat energy form asphalt pavements. *International Journal of Sustainable Engineering*, 4, 164–171 (Taylor & Francis).
- McCormack, A. J. (2010). Resin based surfacing. Paving expert. *AJ McCormack and son*. Web. Retrieved May 8, 2010, from <http://www.pavingexpert.com/resin.htm>
- National Ready Mixed Concrete Association (NRMCA). (2009). *Pervious concrete pavement*. Web. Retrieved December 7, 2009, from <http://www.perviouspavement.org/>
- Portland Cement Association. (2010). *Cement and concrete basics*. Web. Retrieved September 30, 2013, from <http://www.cement.org/basics/>
- Radhi, H. (2009). Evaluating the potential impact of global warming on the UAE residential buildings—a contribution to reduce the CO<sub>2</sub> emissions. *Building and Environment*, 44(12), 2451–2462.
- Santamouris, M., Papanikolaou, N., Livada, I., Koronakis, I., Georgakis, C., Argiriou, A., Assimakopoulos, D. N. (2001) On the impact of urban climate on the energy consumption of buildings. *Energy and Buildings*, 70, 201–216.
- Shahmohamadi, P., Che-Ani, A. I., Maulud, K. N. A., Tawil, N. M., & Abdullah N. A. G. (2011). The impact of anthropogenic heat on formation of urban heat island and energy consumption balance, Urban Studies Research.

- UK Department of Energy and Climate Change. (2009). *Statistics By energy source*. Web. Retrieved May 8, 2010, from <http://www.decc.gov.uk/en/content/cms/statistics/statistics.aspx>
- Wong, E. (2005). Cool pavements. Reducing urban heat islands: compendium of strategies. Washington, DC: EPA.
- Zakaria, R., & Yang, J. (2008) *Smart and sustainable inhabitation in residential industrial neighbourhood for Malaysia. The walking talk on sustainable development issues policies, strategies and techniques* (pp. 1–17). Johor: Penerbit UTM.

# Chapter 17

## Powering Traffic Intersections with Wind and Solar Energy

Mo Zhao and Anuj Sharma

**Abstract** The chapter presents introductory materials to the decentralized small wind and solar energy applications within roadway infrastructure, which aims to provide a reference for transportation agencies to address the unique issues of roadway wind and solar energy projects, and develop project selection criteria for their jurisdictions. This is done by synthesizing an extensive literature review and providing a project evaluation approach to support decision making. The focus of this chapter is to introduce the use of small wind and solar energy as an alternative power source for signalized intersections. Small wind energy usually refers to small wind turbines with a capacity of less than 100 kW, which are typically used for individual homes and farms. This chapter discusses project siting requirements, energy production estimation, and project costing. A framework of primary project development is presented for integrating small wind and solar energy as an alternative power source at signalized intersections. This framework includes identifying appropriate renewable energy technologies and potential sites through a feasibility study, and evaluating project cost-effectiveness through a benefit-cost analysis. The chapter also introduces some data sources for conducting the physical and economic feasibility studies.

### 17.1 Introduction

The transportation sector consumes about 28 % of total energy consumed in the U.S. (Davis et al. 2013). The technological breakthroughs in vehicle efficiency and fuel economy have reduced energy consumption in this sector. The applications of renewable energy technologies in the transportation sector could further shift the transportation-related energy consumption to cleaner alternatives and thus limit Greenhouse Gas (GHG) emissions. In recent years, many state and local

---

M. Zhao · A. Sharma (✉)

University of Nebraska – Lincoln, Lincoln, NE 68583, USA  
e-mail: asharma@unl.edu

M. Zhao

e-mail: mo.zhao@huskers.unl.edu

© Springer-Verlag Berlin Heidelberg 2014

K. Gopalakrishnan et al. (eds.), *Climate Change, Energy, Sustainability and Pavements*,  
Green Energy and Technology, DOI 10.1007/978-3-662-44719-2\_17

455

transportation agencies in U.S. have expressed a growing interest in accommodating renewable energy technologies within highway right-of-way, aiming to increase renewable energy production (Alternative Uses of Highway Right-of-Way. U.S. 2012). Renewable electric power generation within the public right-of-way can cut the energy needed to operate and maintain the highway systems. The excess renewable power generation could also be a potential revenue source for highway agencies. Wind and solar energy as alternative power sources have been used for a wide variety of transportation infrastructure settings (The Louis Berger Group Inc. 2011). The wind and solar power could be a sustainable alternative of grid power for roadway infrastructure.

Wind energy has been used in many industries. The energy production of small wind turbines with rated capacity of 100 kW or less has reached 100 MW in the U. S. with a staggering 15 % growth in the year 2010 (AWEA 2011). The typical site for small wind system is a rural area because the best wind resources are available over flat landscapes. Buildings, trees, signs, and other obstacles in urban areas disrupt available wind resources. Zoning restrictions, financing, and safety are some other considerations that need to be evaluated prior to implementation of a small-wind energy project (Dutton et al. 2002). In recent years, significant effort has been made to meet both technological and policy-related barriers for developing small wind turbine systems. With the development of turbine technologies and power system designs that maximize available wind resources, small wind turbines could reach desired performance in urban and suburban areas.

This chapter intends to provide a reference for the development of applicable strategies to integrate wind and solar energy into highway right-of-way. The following sections introduce the wind and solar energy applications within roadway infrastructure in the U.S. and other countries. The methodology and data sources for evaluating the physical and economic feasibility of wind and solar energy as alternative power sources at signalized intersections are also provided. At the end, a detailed case study is used to demonstrate the methodologies.

## **17.2 Renewable Energy Projects in Transportation Infrastructure**

This section introduces current applications that use transportation infrastructure to generate renewable energy in the U.S. and other countries.

### ***17.2.1 Wind Power Projects***

In June 2009, Maryland State Highway Administration installed a 60-foot tall small wind turbine in the parking lot of the Westminster maintenance facility in Carroll County as a pilot renewable energy project (The Bay Net 2005). A wind turbine

was chosen because of the ease of installation and less cost and maintenance compared to other technologies. The design-build cost of the project was \$25,000. The wind turbine produces an average of 700 kWh energy and reduces approximately 1,400 pounds of CO<sub>2</sub> per month by replacing the use fossil fuels. The designed life of the turbine is 20–25 years.

### ***17.2.2 Hybrid Wind/Solar Power Projects***

Wind resources vary by time of day and season. Wind and solar resources can complement each other in terms of night and day, as well as seasonal variations. In recent years, many parking facilities have been designed to use both wind and solar energy. The Canopy Airport Parking in Denver, Colorado, opened in November 2010 and it uses both wind and solar energy on its parking facility (New Energy Technologies 2010). The parking lot was built with 16.9 kW solar arrays, a 9.6 kW wind turbine farm, and geothermal energy generation. The renewable energy technologies allow building energy savings of 70 % and provide free charging to electric and hybrid vehicles in the parking lots.

In Minnesota, researchers from University of Minnesota developed a self-sustaining hybrid-powered street light to study the benefit of wind and solar energy in supporting rural Intelligent Transportation System (ITS) applications (Taek et al. 2011). A self-sustaining system means that the energy production from the hybrid system should be able to supply the load without any power from the utility grid. The system was installed in the Minnesota Department of Transportation District-1 parking lot, consisting of a 130 W solar panel, a 400 W small wind turbine, and a battery bank of six 6 V 240 Ah batteries. The battery bank provides enough capacity to power the street light for eight days without charging. A 2 year field test found that wind can provide supplementary energy when solar energy is not sufficient. The solar and wind hybrid power generation system along with sufficient battery storage can provide a reliable power source for many remote ITS applications. This study also suggests that a solar and wind hybrid system is cheaper than a grid-tied system for most ITS applications in rural Minnesota. According to this study, the cost of bringing a utility power line to a rural intersection was approximately \$15,840 per mile in Minnesota in 2007. The monthly recurring electricity bills should also be considered. Therefore, the grid power solution would be too expensive for most of rural ITS applications. Compared to the grid power approach, the off-grid hybrid power system can be constructed for less than \$4,000 for most rural ITS applications. The researchers also recommended analyzing the availability of annual wind and solar resources in order to design a system that can maximally utilize the renewable resources.

### 17.2.3 Solar Power Projects

Photovoltaic (PV) solar energy technologies for electric power generation and distribution has been used within the highway right-of-way in several European countries. In the U.S., the first solar highway project was conducted in Oregon (Oregon Office of Innovative Partnerships and Alternative Funding 2008). A ground-mounted PV array was installed at the interchange of Interstate 5 and Interstate 205, and connected to the power grid for clean electricity generation and distribution. The total project cost is \$1,280,000, and the annual electricity production is 112 MWh. In 2012, the Oregon Department of Transportation, partnering with Portland General Electric, installed a 1.75 MW solar array on seven acres of its property adjacent to the Baldock Safety Rest Area on Interstate 5. This project cost approximately \$10 million. The annual energy production from the 6,994,250 W solar panels is about 1.97 GWh (Oregon Office of Innovative Partnerships and Alternative Funding 2012).

The Ohio Department of Transportation installed a 100 kW solar array along Interstate 280 in Toledo. The energy production has been used to offset the electricity demand and operating costs associated with a 196-foot Light-Emitting Diode (LED) lighted structure on the Veteran's Glass City Skyway bridge (Hawaii Department of Transportation 2009).

The Hawaii Department of Transportation installed a solar power system at Lihue Airport in 2009 (Hawaii Department of Transportation 2009). This is one of the seven facilities that comprise the department's PV Energy System Project. The total project are expected to produce 1,200 GWh electric energy each year. Over the 20 year lifetime, the solar arrays can offset up to 26 million pounds of CO<sub>2</sub> emissions that approximate the emission from more than 1,400 cars.

The airport operations officials in El Paso, Texas, installed solar-powered lighting in the facility's long-term overflow parking lot (2009). The project cost \$330,000, which is about 60 % less than a standard lighting installation. The solar lighting project for the 2,200-space parking lot was funded through the Airport Capital Improvement budget. The solar lighting is estimated to save the city \$40,000 per year in electricity costs.

In 2010 a 1 MW solar cell parking lot was constructed at the Manheim NJ Auto Dealers Exchange in Bordentown, New Jersey (Ovidiu 2010). More than 5,000 photovoltaic panels were installed within a total area of 104,000 square feet. The panels were tied into one single meter via eleven separate inverters. This grid-connected system can generate more than 1 GWh electric energy per year, which is roughly the amount to power 114 households.

Many "green rest areas" or "Eco-Friendly Rest Areas" along the national highways are being designed as energy saving buildings, like the Green Rest Stop on Interstate 89 in Sharon, Vermont, and the rest areas on U.S. Highway 287 west of Chillicothe, Texas. Some of the green rest areas have installed renewable energy generation facilities. The North Carolina Department of Transportation opened the Northwest North Carolina Visitor Center on October 2009, which is located on the northbound side of U.S. highway 421 in North Wilkesboro (NCDOT 2009).

The 10,030 square-foot green rest area cost \$12 million to build. It has roof-mounted solar panels to preheat water for restrooms. Fourteen photovoltaic panels are expected to produce nearly 4.4 MWh per year.

The SpeedInfo Company uses solar-powered Doppler radars in its wireless network to collect traffic flow information in many metropolitan areas in the U.S. (Speedinfo.com 2007). The sensors are attached to transportation infrastructure such as traffic poles and the real-time traffic data are sent via the AT&T® Wireless network.

One common application of solar energy in roadways is solar-powered ITS program signage and temporary signals. The solar-powered signs may be temporary or permanent, and these applications include Dynamic Message Signs (DMS), variable message signs (VMS), portable changeable message signs (PCMS), and variable message boards (VMB).

### ***17.2.4 International Applications***

Renewable energy projects are being developed all over the world. However, solar power seems to have a wider implementation compared to the other energy forms. The following paragraphs discuss international applications that use transportation infrastructure to produce renewable energy.

In Germany, 2.7 MW solar panels were installed on 8,858 feet of the roof of the A3 highway tunnel.<sup>1</sup> The first phase of construction was completed in 2009. The local electricity company, Goldbach-Hoesbach, purchased the land from the German government and oversaw the project's connection to the power grid. The €11 million (\$15 million) investment is expected to be paid back through cost savings over 16 years.

The Australian renewable energy retailer Going Solar produces solar panels that can be installed as sound barriers for highways (Inhabitat 2008). The footprint of this sound barrier is minimal as the solar panels are mounted vertically. The first highway installation was completed on the Tullamarine Calder Interchange in Australia. The solar sound barrier comprises 1,640 feet of PV panels that are attached to a public display showing the project's power output. The project provides 25 kW of peak power output and is expected to produce 18.7 MWh per year, which is enough to cover its cost in about 15 years. The solar energy production is consumed by the near residential areas. By installing solar panels, the sound barrier provides noise reduction with aesthetic appeal as well as environmental sustainability.

In 2011, the world's first totally solar highway was opened in Italy (Energy Digital 2010). The approximately 19 mile highway between the cities of Catania and Syracuse cost \$81 million to construct, and use PV panels to power all of the

---

<sup>1</sup> <http://www.renewableenergyworld.com/rea/news/article/2009/02/2-8-mw-a3-highway-solar-system-nears-completion>.

highway's system including tunnel fans, lights, road signs, and emergency telephones. The estimated annual solar power production is 12 GWh.

The Vauxhall Cross Bus Interchange in London, United Kingdom was built in 2005 at the cost of about \$5,800,000 (Transport for London 2005). 168 Sanyo 180 W solar modules were installed on the interchange's canopy, and generate 30 % of the energy required to power the 24-h bus station area. The Walworth Bus Garage in London also has 744 solar panels on the roof that generate 38.5 MWh of electric power each year.

The Rainbow Bridge in Tokyo, Japan, is illuminated with 444 solar-powered lamps that change color with the seasons (ACTIVE Corporation 2008).

The renewable energy projects in various transportation infrastructures have the potential to change the role of transportation sector from a big energy consumer to an energy provider, and to create green collar jobs for local communities.

### *17.2.5 New Concepts and Techniques*

The significant technological innovations in renewable energy are instrumental in achieving the goal of green transportation. Portable traffic signal systems powered by solar panels are common applications of renewable energy in ITS. These products have been available in the market for many years. Solar arrays and small wind turbines have historically been used in rural areas or off-grid systems, but many new technological innovations can help accommodate renewable energy in urban transportation systems.

The Solar Roadways project has been developing and testing a solar roadway by combining a series of structurally-engineered solar panels (Solar Roadways 2010). By replacing existing transportation infrastructure like roads and parking with novel solar road panels that collect energy and provide sensor data, this technology is proposed to save excess energy in or alongside the roadways. The solar road panel consists of three layers: a road surface layer made of translucent glass which is able to provide strength and traction while letting sunlight pass through, an electronic layer that collects power from sensors and hosts some circuitry, and a base plate layer for power and data distribution. The first prototype of a 12-ft by 12-ft road panel was built in February 2010.

Scientists in Korea have developed an On-Line Electric Vehicle (OLEV) charging system that can wirelessly charge vehicles through induction systems using power from underground electric coils (Suh et al. 2010). With this new wireless technique, it is possible to charge electric and hybrid vehicles on the road with renewable energy generated and distributed along the roadways. For the OLEV buses that follow pre-determined routes, the underground electric power coil can be installed on critical segments of the road, such as bus stations and intersections with stoplights. The researchers discovered that most vehicles would be able to drive around the city and recharge the battery on the move if about 30 % of the roads in Seoul had the underground electric power coil installed. In 2013, two



commercial OLEV buses began to operate on a 7.5 mile (12 km) route in Gumi, Korea (Leo 2013). The researchers noted that the electromagnetic field was weak and would not pose a health risk to pedestrians, however, the construction of an underground electric coil may cause some problems with pavement life and maintenance practices. Further research is needed to evaluate these impacts.

The Green Roadway (TGR) project developed the technology portfolios to provide patented alternative energy systems for installing massive solar, wind, geothermal, and electric vehicle infrastructure systems along roadways (The Green Roadway Project 2010). The power from the roadway energy systems may be used to supply vehicle charging stations, homes, and businesses, or to deliver to the grid. The exclusive licenses of TGR were obtained by individual states via sealed bid auction in July 2009. These technology portfolios will contribute to standards of renewable energy applications in transportation.

New Energy Technologies Inc. developed a prototype of an energy harvester system, MotionPower™, which generates electricity by vehicle movement. Field tests were undertaken at a Burger King drive-thru in Hillside, New Jersey in 2009 (New Energy Technologies 2010). The harvesting system could potentially be installed in high traffic areas that require vehicle deceleration, such as traffic intersections, toll booths, rest areas, and drive-through areas. Electric energy is generated when vehicles pass along a contiguous deformable roadway surface that compresses a fluidizing system interacting with mechanical fixtures to produce electrical energy. A similar technology has been tested out in the United Kingdom. The electro-kinetic road ramp developed by the UK Highway Energy System can generate electricity when vehicles pass the articulated plates placed in the road (Mark 2009). The output of the generator varies from 5 to 10 kW depending on the frequency and weight of traffic. UK supermarket chain Sainsbury's installed the electro-kinetic plates in its car parks in 2009, expecting to generate 30 kWh electric energy to power the store's checkouts. If these kinds of technologies could be widely used, the vehicle-miles travelled would bring immense economic and environmental benefit. Similar to the OLEV charging system in Korea, both the MotionPower™ system and the electro-kinetic road ramp require reconstruction of roadway surfaces, which may cause problems to existing roadway pavements and concerns about traffic safety.

### ***17.2.6 Summary***

Small wind and solar energy systems have great potential in the rapidly evolving transportation sector. However, there is still a lack of a standard implementation specification and effective project development tools. Most of the current deployments are individual efforts by state or local agencies to test a new technology. There is a strong need to document these scattered efforts and provide some guiding business models that can be followed for implementation. There is also a need to develop guidelines for assessing economic, social, and environmental impacts.

The small wind and solar energy applications within transportation infrastructure are still new and only limited studies and experiences of using these power sources are available. There are considerable economic, safety, environmental, and political uncertainties concerning whether the use of wind and solar energy technologies along roadways is viable. A successful deployment of small wind and solar energy projects for traffic intersections requires comprehensive investigations of both infrastructural and economic viability.

The following sections discuss the physical and economic feasibility of using small wind and solar energy to power traffic intersections. Focus is placed on the application of small wind and solar power system mounted on existing traffic poles. This pole-mounted renewable energy system can be used as an alternative for traditional grid power to retain normal traffic signal control in case of grid power outages. To be mounted on the pole with traffic lights, the small wind turbines discussed following are smaller light-weight turbines, usually 1 kW or less. Generally, a 1 kW wind turbine weighs between 50 and 100 lb. On traffic signal mast arms, a 12 inch aluminium signal head weighs about 50 lb and a polycarbonate one of the same size weighs about 30 lb. The physical feasibility check process would include investigations of structural strengths of traffic poles, zoning ordinance, site-specific geographic features, and potential negative impacts. The economic feasibility check is used to evaluate cost-effectiveness of the project. A framework of a physical and economic feasibility check is shown in Fig. 17.1. The details of the analysis methods are provided in Sects. 17.3 and 17.4.

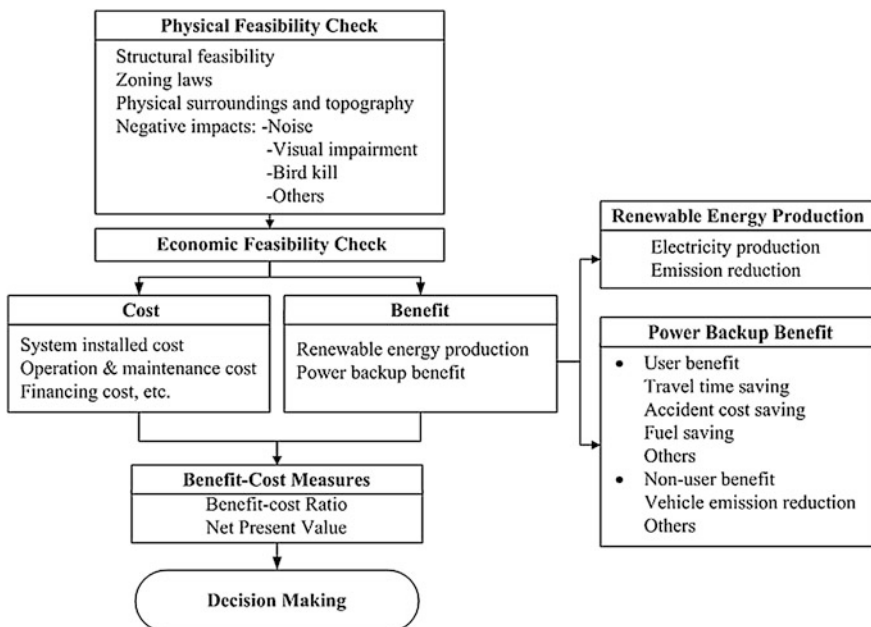

Fig. 17.1 Framework for physical and economic feasibility analysis

## **17.3 Physical Feasibility of Using Wind Energy at Signalized Intersections**

The primary criteria of a feasible site for traffic-pole-mounted small wind energy systems include the requirements on traffic pole structure, zoning laws, and site topography. Negative impact should also be considered. Wind turbines make noise and may cause aesthetic and ecological problems. Noise is created during the construction and operation of the system. The ecological impact is mainly the increased number of bird kills near the turbine site.

### ***17.3.1 Zoning Laws***

As zoning ordinances vary at different levels of government, those dealing with small wind turbine installation need to be determined prior to installation. In the U.S., federal zoning laws have some restrictions to protect air traffic, which affects turbine towers higher than 200 feet and turbines installed within 10 miles of air strips. Small wind turbines are usually mounted on towers of 130 feet (40 m) or less. State and local zoning laws should also be checked. The zoning laws often can be obtained from the local planning department. The state energy offices usually provide information concerning the placement of small wind turbines and solar panels, which may include local wind and solar resources data, renewable energy projects statistics, financing and permitting resources.

### ***17.3.2 Physical Surroundings and Topography***

The height of the turbine tower and nearby obstacles as well as the site topography all affect the wind resource availability. Because of zoning restrictions and fixed heights of existing traffic poles, it is impossible to increase the energy production by increasing the mounted height. To maximize production, wind turbines should be sited upwind of any obstacles in order to harness the strongest wind. Buildings, trees, traffic signs, and other obstacles can disrupt wind flow and cause turbulence. Turbulence reduces power generation and causes additional stress on the wind turbine and signal pole. The efficiency of a wind turbine also decreases if wind direction is not horizontal due to any obstruction. Built environments have a significant impact on incoming wind, especially in urban areas, and therefore make it difficult to site the turbine (Stankovic et al. 2009). The obstacles in urban and suburban areas raise the effective ground level for wind to the height of the surrounding structures (Sharman 2010). The report “*A Siting Handbook for Small Wind Energy Conversion Systems*” provides detailed information about small wind project siting (Wegley et al. 1980). Autodesk® Vasari is a design tool that allows

users to analyze wind data from Autodesk's Climate Server through dynamically simulating the impact of wind speed and direction (Autodesk® Sustainability Workshop 2013). An obstacle creates turbulent wind flow twice as tall as the obstacle's height (H) and twenty times as long (Sarah 2011). To site the wind turbine above the areas of turbulence created by surrounding obstacles and get maximum air flow, it is critical to be least 20H away from an obstacle of height H. Field studies are necessary to check the surroundings and terrain. It becomes critical to have a site-specific evaluation if any obstruction is present.

### 17.3.3 Negative Impacts

Noise, aesthetics, visual impairment, ecological problems, and other potential negative impacts should be considered for wind turbine installation and operation. Small wind turbines must be approved by the American Wind Energy Association and the noise of turbine should not exceed 60 dBA as measured at the closest neighboring inhabited dwelling unit. The sound level of small wind turbine during different operation modes can be found in the owner's manual or obtained from the turbine manufacturer. These sound levels can be compared to the background noise level at a subject site to identify the significance of turbine noise. The best way to obtain an accurate background noise level is through a field study with a sound meter. The Federal Highway Administration (FHWA) Traffic Noise Model (Traffic Noise Model 1998) provides estimations of traffic noise at different speed limits and distances, which can be used if a field study is not available. The combined level of noise from a wind turbine and traffic can be calculated by Eq. 17.1.

$$L_{\Sigma} = 10 \log \left( 10^{\frac{L_1}{10}} + 10^{\frac{L_2}{10}} \right) \quad (17.1)$$

where  $L_{\Sigma}$  is the combined level of noise (dBA),  $L_1$  (dBA) is the noise level of wind turbine, and  $L_2$  (dBA) is the noise level of background traffic. According to the FHWA Traffic Noise Model (Traffic Noise Model 1998), the typical noise levels of passenger vehicles travelling at 55 mph are 72–74 dBA measured at a distance of 50 feet. The sound level of a Bergey 1 kW wind turbine is approximately 50 dBA under normal operation measured at 42 feet downstream of turbine tower, which would not significantly increase the noise level at a high-speed intersection. Traffic noise may mask the noise from the small wind turbine. Another concern about turbine noise emission is the low-frequency noise, which is generated by rotation of turbine blades. Small wind turbines have higher rotational speeds than the large ones and generate audible low frequency noise. Long-term exposure to audible low-frequency noise can be harmful to human health. Research conducted by the National Research Council states that sensitivity to wind turbine low-frequency noise is highly variable among individuals, and the effects of low-frequency noise on human beings are not well understood (National Research Council 2007).

The siting of roadside wind turbines should be carefully considered to avoid adverse health effects in humans.

In terms of ecological impact, one common concern regarding wind turbines is the increased number of bird kills near the turbine site. Turbine manufacturers may provide references on this issue. The bird kills are usually a problem for large wind turbines. Researchers from the University of Oklahoma conducted a study for a small wind turbine manufacturer, and found the small turbine did not have any statistically significant impact on the bird population in the study area (Small wind and letter 2001). A briefing paper by the Distributed Wind Energy Association (DWEA) shows that small wind turbines are safe if well-documented practices are followed, and that trees and other structures carry greater inherent danger to individuals and property than small wind turbines (Distributed Wind Energy Association 2010).

A field study should be conducted to determine the visual impacts. Generally, the small size wind turbine has a rotor diameter less than 50 feet (15 m). Site-specific investigation is needed to find out if the blades would cause shading problems.

### ***17.3.4 Structural Analysis***

Wind and solar power generators are innovative designs that harness natural energy. Large scale designs of these structures have been efficiently implemented throughout the country, producing high levels of energy and substantial monetary savings. Traffic-pole-mounted small wind and solar power system is an innovative application to power traffic lights, but the structural stability of traffic poles is a critical limit for the design and implementation of such power systems.

Ideally, the dynamic effects that wind loading has on a pole-mounted small wind turbines and solar panel systems should be evaluated through in-field testing. Evaluations under variable, dynamic loads would be extremely difficult because the enormous permutations and combinations of wind magnitude and frequency lead to drastically different stresses. Therefore, an alternative method was developed using the static allowable stress analysis outlined in the American Association of State Highway and Transportation Officials (AASHTO) guide *Standard Specification for Structural Supports for Highway Signs, Luminaires, and Traffic Signals* (American Association of State Highway and Transportation officials 2009). Sharma et al. conducted a structural analysis using this method with traffic pole specifications and wind data (Sharma et al. 2012). Their study investigated the dynamic effects of mounting a small wind turbine and solar panels onto existing luminaire. The small wind turbine selected for their analysis was a 1 kW turbine of 75 lb, which is designed for installation heights greater than 30 feet and requires 44 inches of blade clearance. The solar panels were given an area of 15 square-feet and up to two panels could be installed on a single traffic signal structure. Although the orientation angle at which a solar panel is installed depends on the specific site location, all

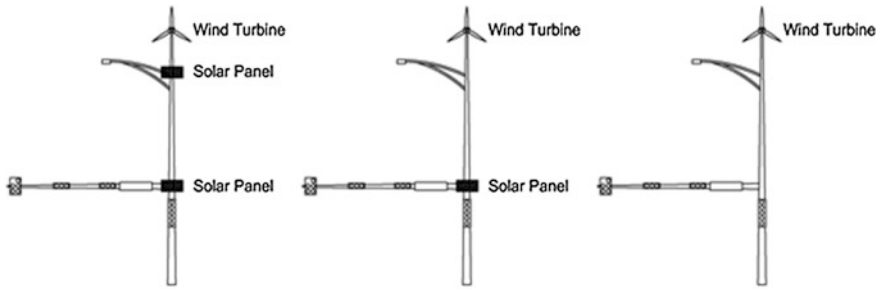

**Fig. 17.2** Design configurations of a pole-mounted wind turbine and solar panels (Sharma et al. 2012)

solar panels were conservatively assumed to be mounted at a  $45^\circ$  angle from vertical. Additionally, the solar panels were assumed to face the same lateral direction as the traffic signals. Three critical design configurations were identified: (1) a wind turbine and two solar panels; (2) a wind turbine and a single solar panel; and (3) a wind turbine only. Those configurations are shown in Fig. 17.2. The wind turbine was always mounted to the top of the traffic pole (above the luminaire). To ensure the turbine blades had adequate clearance, the turbine was mounted at a height of 5 feet greater than the nominal mounting height of the luminaire. For example, if the nominal height of the existing luminaire system was 40 feet, the pole was extended such that the wind turbine was centered at a height of 45 feet. Higher mounting locations would result in increased loads and stresses applied to the existing structure. Thus, when two solar panels were to be used, the first was mounted at the top of the existing pole (outside the required blade clearance) while the second was located near the mast arm attachment point. When only a single solar panel was to be used, it was mounted at the mast arm attachment point.

In that study, 22 traffic signal pole designs were analyzed with 3 different luminaire mounting heights, 3 design configurations, and 3 load combinations. A total of 594 analyses were conducted to determine the structural feasibility of mounting the wind turbine and solar panel attachments to existing traffic signal poles. A summary of the evaluation results is shown in Table 17.1. Nearly all of the 30-foot poles were structurally strong enough to support a wind turbine and two solar panels. Structural feasibility reduced as pole height increased: for 50-foot poles, neither a wind turbine nor a solar panel could be mounted.

It should be noted that the recommendations illustrated in Table 17.1 were made utilizing multiple design assumptions: (1) all existing connections (except for the anchor bolts) and new attachments connections have adequate strength capacity to sustain the additional loads, and (2) the foundation of the existing structure has adequate strength capacity to withstand the additional loading. Both of these assumptions should be evaluated before attaching either a wind turbine or solar panels to an existing traffic signal pole. This analysis was based on the recommended evaluation procedures of the 2009 AASHTO *Standard Specification for*

**Table 17.1** Summary of traffic signal pole attachment feasibility (Sharma et al. 2012)

Pole design	Pole base diameter (in.)	Pole base thickness (ga or in.)	Anchor bolt circle diameter (ft.)	Anchor bolt diameter (ft.)	Signal arm span (ft.)	Luminaire mounting height (ft.)		
						50	40	30
1	13	7	17	1.5	18	–	T, 1P	T, 2P
2	13	7	17	1.5	20	–	T, 1P	T, 2P
3	13	7	17	1.5	22	–	T, 1P	T, 2P
4	13	7	17	1.5	24	–	T, 1P	T, 2P
5	13	7	17	1.5	26	–	T, 1P	T, 2P
6	13	7	17	1.5	28	–	T, 1P	T, 2P
7	13	7	17	1.5	30	–	T, 1P	T, 1P
8	13	7	17	1.5	32	–	T	T, 1P
9	13	3	17.5	1.75	34	T, 2P	T, 2P	T, 2P
10	13	3	17.5	1.75	36	T, 1P	T, 2P	T, 2P
11	13	3	17.5	1.75	38	T, 1P	T, 2P	T, 2P
12	13	3	17.5	1.75	40	T, 1P	T, 2P	T, 2P
13	13	3	17.5	1.75	42	T	T, 1P	T, 2P
14	13	3	17.5	1.75	44	–	T, 1P	T, 2P
16	13	3	17.5	1.75	46	–	T	T, 1P
17	15	0.25	20.5	2	48	–	T	T, 1P
18	15	0.25	20.5	2	50	–	–	T
19	15	0.31	20.5	2	55	T, 2P	T, 2P	T, 2P
20	15	0.31	20.5	2	60	T, 2P	T, 2P	T, 2P
21	15	0.31	20.5	2	65	T, 2P	T, 2P	T, 2P
22	15	0.31	20.5	2	70	T, 1P	T, 2P	T, 2P

(continued)

**Table 17.1** (continued)

Pole design	Pole base diameter (in.)	Pole base thickness (ga or in.)	Anchor bolt circle diameter (ft.)	Anchor bolt diameter (ft.)	Signal arm span (ft.)	Luminaire mounting height (ft.)		
						50	40	30
23	15	0.31	20.5	2	75	T, 2P	T, 2P	T, 2P

T, 2P = Turbine and both solar panels can be mounted  
 T, 1P = Turbine and the bottom solar panels can be mounted  
 T = Turbine only can be mounted  
 – = No attachments can be mounted

*Structural Supports for Highway Signs, Luminaires, and Traffic Signals* in lieu of actual physical testing. The dynamic loading effects of the wind turbine were reduced to the manufacturer’s prescribed maximum thrust of 200 lb. Although the fatigue analysis was viewed to be conservative, physical testing is needed to provide greater confidence.

### 17.4 Economic Impact Analysis

This section discusses the methodology to conduct an economic feasibility study for Roadway wind and solar Hybrid Power System (RHPS) as an alternative power source for signalized traffic intersections. The RHPS discussed here is grid-connected and will be mounted on traffic signal poles.

The benefits of the RHPS is two-fold: the power generated by wind and solar generators can power traffic signal system and any excess power can be sold back to the power grid, and it also provides a source of backup power in case of grid failures, which increases the reliability of traffic operations. This section presents the methodology to ascertain the economic benefits of the RHPS for both the cases described above. The benefit and cost of providing a RHPS are stated in terms of US\$-values. Benefit-cost ratio and net present value can be calculated and used as measures of cost-effectiveness to determine the economic viability of RHPS installation at a specific site. In case of budget constraints, the methodology can be used to prioritize project locations using benefit-cost ratios and net present benefits.

The benefit and cost items discussed here are selected based on the criteria discussed in the AASHTO manual *User and Non-user Benefit Analysis for Highways* (American Association of State Highway and Transportation officials 2003). This manual is a useful resource for analyzing the economic effectiveness of transportation projects. The following paragraphs present the methods to estimating cost and benefit of a roadway wind and solar hybrid power system.



### 17.4.1 System Costs

The total cost includes the cost of the RHPS components, cost of installation, operation, and maintenance, financing cost, etc. The cost may vary by system configuration and the hardware used. Small wind turbines and solar panels are low-maintenance over their life time. The manufacturer or contractor should be able to provide a list of maintenance strategies and associated costs.

### 17.4.2 System Benefits

The benefits from the RHPS include the electricity production and benefits derived from serving as a backup power during grid power failures. When traffic control signals at an intersection are not in operation, most states in the U.S. require reversion to all-way-stop controlled operation. This operation would result in congestion and substantially riskier operations at a signal controlled intersection, especially during traffic peak hours. The presence of RHPS at a signalized intersection can reduce the electricity purchase to operate the signals, and improve the reliability of traffic control system by providing backup power. The benefit of RHPS as backup power during grid power failure is named power backup benefit in this chapter. The power backup benefit is classified into two types: user benefit and non-user benefit. The definition of user and non-user benefit can be referred to the AASHTO Manual, *User and Non-user Benefit Analysis for Highways* (American Association of State Highway and Transportation officials 2003), which is often called the AASHTO Red Book. Figure 17.3 list the RHPS benefits that may be included in the benefit-cost analysis. The user benefit includes the travel time benefit, safety benefit (accident cost saving), and fuel cost savings. The non-user benefit may include the reduction on vehicle emission and other benefits like

Fig. 17.3 Benefit items

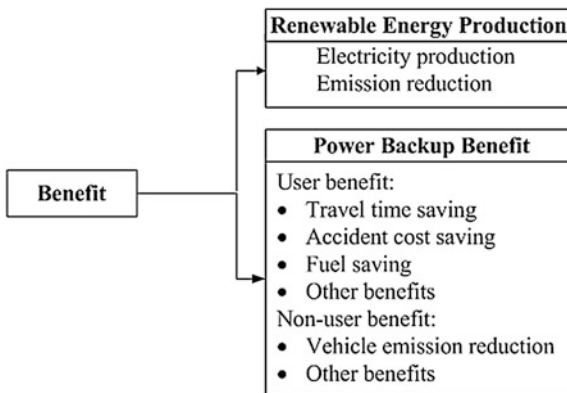

savings on traffic directing and signal maintenance personnel. The cost and benefit items to be included in the economic analysis should be selected with care based on site-specific situations.

### 17.4.2.1 Renewable Energy Production

The benefits from renewable energy production include the energy used to power traffic intersection and the sales of any excess production. A feasible site should have enough wind or solar resources to make the RHPS economical. The theoretical energy in wind varies as the cube of the wind speed (Tore 2007). Wind speed increases as height above the ground increases. Wind resource maps provide an estimate of the potential resource in a given area. Most wind resource maps available are for the height of 164 feet (50 m) and higher. A wind map of annual wind speed at 33 feet (10 m) is recommended, as the RHPS will be installed on a traffic signal pole. The U.S. Department of Energy provides rich data on wind and solar resources. The National Renewable Energy Laboratory and state energy offices are good sources for wind resources. Wind and solar data from roadway weather stations, such as Clarus Initiative, and networks operated by local transportation agencies can also provide useful information.

#### Electricity Production

As alternative power sources to traditional grid power, wind and solar energy production from RHPS would reduce the cost to operate signalized intersections. The excess energy production over the demand of powering traffic lights can be sold back to the utility grid. It is necessary to contact local utility agency and confirm the requirements of grid connection and options for sale of renewable power.

Many on-line tools are available for estimating wind and solar energy production. A bin method can also be used to estimate the electricity production with wind data and wind turbine power curve (International Electrotechnical Commission (IEC) 2005). The power curve provided by manufacturer typically gives the output at different wind speeds with an assumption of sea level air density of  $1.225 \text{ kg/m}^3$ . The estimated energy output should be normalized to sea level air density using a wind speed correction. Usually, the 10 min average speed is used in the bin method. The 10 min average wind speed data are discretized into speed bins with certain bin width, usually 0.5 or 1 m/s. The power output for each corresponding speed bin is obtained from turbine power curve. The total output can be estimate by summing up the output from each speed bin. Many on-line tools can estimate solar energy production in a given area, such as the PVWatts by the National Renewable Energy Laboratory of U.S. Department of Energy. The benefits from electricity production can be calculated from the estimated energy production and electricity price.

**Table 17.2** Emission saving from generating electricity from wind energy

	CO <sub>2</sub>	SO <sub>2</sub>	NO <sub>x</sub>
Total emission (1,000 MT)	2,269,508	5,970	2,395
Net generation (1,000 MWh)	2,726,452		
Emission rate (ton/kWh)	8.32 E-04	2.19E-06	8.78E-07

### Emission Reduction

The RHPS generates electric power using renewable energy resources instead of fossil fuels. In the U.S., the net electricity generation from fossil fuel and total pollutants from conventional power plants can be obtained from Energy Information Administration (EIA) annual statistics (Annual Energy Review 2010). The emission per kWh generation can be estimated from these statistics. Table 17.2 shows an example based on the EIA annual statistics in 2010. Knowing the electricity generation and unit cost of the pollutant, we can estimate the monetary benefits from emission reduction.

#### 17.4.2.2 Power Backup Benefit

The RHPS can provide backup power to maintain normal traffic signal operations during grid power outages. The benefits as backup power can be estimated by comparing the loss of operational efficiency if such a system is not present. The benefits might include delay reduction, safety improvement, vehicle fuel saving, emission reduction, and personnel saving. It is important to correctly identify the primary benefits to be included in the economic analysis.

Table 17.3 provides a summary of methods that can be used to evaluate the benefits. These methods can be classified into two categories: empirical equation-based analysis and microscopic simulation-based analysis. The *Highway Capacity Manual* (HCM) provides some methods to estimate delay at signalized intersection and all-way stop controlled intersection (TRB 2010). When field evaluation is not feasible, simulation-based methods could be used. The trade-off between using empirical equation versus microscopic simulation concerns time and accuracy. The microscopic simulation-based analysis will provide a more accurate estimate but will take longer for model calibration and result analysis. Sufficient crash data during power outages would be ideal to estimate the crash reduction by preventing dark signals, however, this kind of data is usually unavailable. Traffic conflict can be used as a surrogate for safety. The vehicle trajectories from microscopic simulation models can be analyzed using the FHWA Surrogate Safety Assessment Model (SSAM) (Gettman et al. 2008) to obtain the frequency and severity of traffic conflicts under simulated conditions.

**Table 3** Methods to evaluate benefit measures

Measurement		Method	
		Empirical equation-based	Microscopic simulation-based
Delay	Signal control ( $d_s$ ):	HCM method (TRB 2010) Eq. (20–30), (20–31) & (20–32)	Microscopic simulation models
	All-way stop ( $d_a$ )	HCM method Eq. (20–30), (20–31) & (20–32)	
	Reduction ( $d_r$ )	$d_r = d_a - d_s$	
Crash reduction		Crash data	Traffic conflict study using SSAM
Fuel saving		AASHTO method (American Association of State Highway and Transportation officials 2003): $g(D_0 - D_1)p$	Emission software using trajectories generated by Micro-simulator
Vehicle emission reduction		Empirical fuel-based model	Emission software using trajectories generated by Micro-simulator

### Travel Time Saving

Providing backup power at signalized intersection is an effective way to avoid the delay caused by all-way-stop control during power outages. Studies have shown that reducing one minute on average experienced lateness is valued very close to reducing travel time (Tilahun and Levinson 2010). Delays under different control types for a specific intersection can be estimated respectively by the methodologies provided by the *Highway Capacity Manual* (TRB 2010). Another approach is to use micro-simulation models to estimate delays under different control types.

### Accident Cost Saving

The RHPS can maintain normal signal operation during grid power outages and therefore reduce the risk of crashes at signalized intersections. A study conducted by the California Energy Commission found that a typical traffic signal intersection experiences eight to ten local power outages annually, and the application of backup power for traffic signals was found to increase public safety, reduce traffic congestion, and eliminate the need of police traffic directing (California Energy Commission 2004). A direct way to estimate the safety benefits would be to use the crash records during power outages, but this kind of data is rarely available. Traffic conflict has been used as a surrogate measure of safety. With the vehicle trajectories from microscopic simulation models, the FHWA SSAM (Surrogate Safety Assessment Model 2008) can be used to obtain the frequency and severity of traffic conflicts under simulated conditions.

## Fuel Saving

With wind and solar energy as backup power, the RHPS has the potential to avoid the extra fuel consumption caused by the stop-and-go traffic under all-way-stop control at signalized intersection during grid power failures. The fuel saving might not be a primary benefit compared to delay and accident cost saving. The AASHTO *Red Book* provides methods to estimate change in fuel consumption in gallons per minute of delay for different vehicle types and speed limits (American Association of State Highway and Transportation officials 2003). Another way to estimate the change in fuel consumption is through simulation. Some micro-simulation software packages like PTV Vissim have an optional module for fuel consumption. Other vehicle emission software packages such as MOVES (Motor Vehicle Emission Simulator) can also estimate the fuel consumption using vehicle trajectories exported from a micro-simulator. The price of fuel can then be multiplied by the change in fuel consumption to obtain the dollar values.

## Vehicle Emission Reduction

Increasing attention has been focused on reducing transportation-related emissions in recent years. The environmental impact is classified into primary non-user benefits in the AASHTO *Red Book* (American Association of State Highway and Transportation officials 2003). The reduction in vehicle emission could be considered when the fuel saving is significant. An empirical fuel-based model can be used for quick estimations of vehicle emissions as shown in the following list (Cobian et al. 2009):

- $\text{CO} = \text{Fuel consumption (gallon)} \times 69.9 \text{ g/gallon}$
- $\text{NO}_x = \text{Fuel consumption (gallon)} \times 13.6 \text{ g/gallon}$
- $\text{VOCs} = \text{Fuel consumption (gallon)} \times 16.2 \text{ g/gallon}$

Another method to estimate vehicle emissions is to use vehicle trajectory-based emission models. Many vehicle emission models now are available, such as MOVES and CMEM (Comprehensive Modal Emissions Model). MOVES uses vehicle trajectories from traffic simulation models as inputs, which including data on speed, location, and acceleration for each vehicle.

The unit cost of pollutants is needed to estimate the environmental benefit in a dollar value. The monetary costs of air pollutants are typically measured in three ways (Sinha and Labi 2007): (1) as the cost of cleaning the air near the source of degradation, (2) as the cost associated with addressing the effects of degradation, and (3) as the willingness of persons to pay to avoid the degradation. The choice of method to measure pollutant cost in a US\$ value depends more on user preference. The Social Cost of Carbon (SCC) is an estimate of monetized damage cost of an incremental increase in carbon emissions in a given year. The SCC assesses damages to ecosystems, freshwater resources, forests, coastal areas, human health, and industry (IPCC 2007). The U.S. Department of Transportation used a domestic SCC

value of \$2 per ton of CO<sub>2</sub> in the final model year 2011 Corporate Average Fuel Economy rule. Muller and Mendelsohn proposed a method to estimate the marginal damage cost for several kinds of pollutants (Muller and Mendelsohn 2009).

### 17.4.3 Example

The example was conducted for the intersection of Nebraska Highway 2 and 84th Street in Lincoln, Nebraska (Zhao et al. 2013). Figure 17.4 shows a picture of this test site. The intersection installed one 1 kW wind turbine, two 210 W solar panels, and a battery bank with four batteries. In Lincoln, a grid-connected renewable energy project should be submitted approved by the local utility service prior to the connection with the grid. An agreement was made with the local utility agency to sell back the instantaneous surplus of power output at the same rate of purchase from the utility.

At the time of the study, the solar radiation data was not enough to perform a sound analysis, therefore the studied RHPS includes wind turbine and battery system only. The system installation cost was \$8,223, which includes the installed costs of one 1 kW wind turbine, one power grid interactive inverter and charger, one battery power monitor, and four 6 V 305 Ah batteries. The system has been maintained by local signal operating agency. Preventive maintenance recommended by the turbine manufacturer includes re-greasing the bearings every 8–12 years and checking blade stiffness every 10 years. For a 15 year analysis period, the total operation and maintenance cost of the wind turbine was assumed to be 5 % of its installed cost. The average electricity consumption at the test site with 24 LED



**Fig. 17.4** Test site in Lincoln, NE

signal heads was around 325 kWh per month. The estimated electricity production from the RHPS was about 230 kWh per month. This estimation was based on local wind resources and turbine power outputs described by the turbine power curve from the manufacturer.

In Nebraska, the state law requires the intersection to be treated as a multi-way stop when the traffic signal is dark with no indication and traffic direction is not provided (Nebraska Legislature 2010). The normal signal operation was considered as a baseline scenario and an all-way-stop controlled operation was used to simulate operations during power outages. The average annual benefit from the RHPS was approximately \$660 at the test site; about \$450 was from power backup benefit, while \$210 was from wind energy generation at local electricity price of \$0.075 per kWh. In the 15 year analysis period, the total savings created by the RHPS was about \$15,200 at a 3 % inflation rate. It would take more than 9 years to reach the breakeven.

The benefits estimated in the case study were conservative. The designed system lifecycle as claimed by manufacturer is 25 years—as compared to the 15 years used in the analysis—meaning there would be more energy production and other savings. Only unplanned power outages were considered in this analysis.

Although the benefits of reducing traffic congestion and crash risk are obvious, there is currently no standard way to quantify those benefits from providing backup power for traffic signals. Some transportation agencies have their own specification to evaluate the benefits, and the cost might be seen as recovered if one life was saved because of presence of the RHPS. In addition, the RHPS can provide fluctuation-free power, which would reduce the risk of controller malfunction and thus improve the reliability of traffic control system.

#### 17.4.3.1 Extension of Battery Capacity

The battery bank at the test site can supply for traffic signal's full operations for 4–6 h at 50 % battery discharging level. When wind and solar resources are available during power outages, the normal signal operation can be further extended with on-site energy production. The benefit from extended power backup capacity is not included in the total benefit discussed in Sect. 17.4.2, but this benefit may be significant when the power outage is much longer than the backup time of the battery bank. Figure 17.5 shows the 95th, 50th and 5th percentiles of estimated 4 h wind energy productions at the test site. Wind data in a 4 h period were used as one sample unit and the samples were randomly selected from a dataset for 1,676 days. The 50th percentile estimates converge as the sample size increases. The average 4 h wind energy production was approximately 1.28 kWh, which can power the signal system for about 3 h. In this case, the on-site wind energy production together with a full-charged battery bank can supply full signal operation for about 7 h.

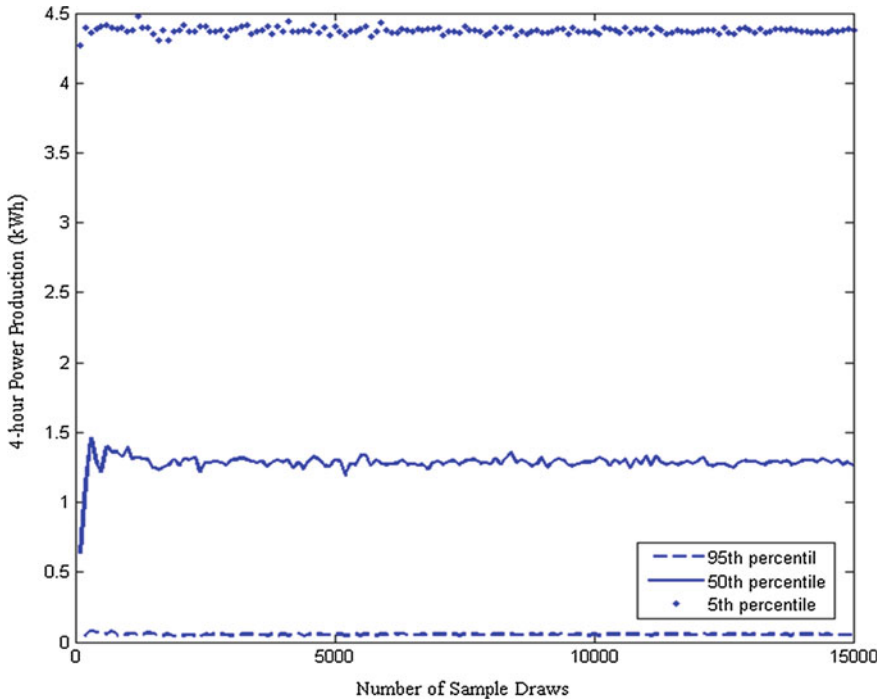

Fig. 17.5 Estimates of 4 h wind energy production

## 17.5 Chapter Summary

This chapter introduces the small wind and solar energy applications in transportation infrastructure with a focus on the applications at signalized intersections. As an alternative power source, properly designed wind and solar power system could be beneficial at intersections with frequent power interruptions. Methodologies for investigating physical and economic feasibilities of wind and solar energy as alternative power for traffic control signals are presented. Structural analysis would verify the stability of traffic pole and foundation for accommodating small wind and solar power system. In economic analysis, it is critical to decide the benefit and cost items to be included in the analysis. There is currently no standard way to evaluate the benefit and cost of a power backup system for traffic control signals. In this chapter, the travel time benefit, accident cost saving, vehicle operating saving and environmental impact defined in the AASHTO *User and Non-user Benefit Analysis for Highways* (American Association of State Highway and Transportation officials 2003) were considered. Benefit-cost ratio and net present value can be used as measures of economic effectiveness. For sketch planning purpose, intersections can be prioritized based on benefit-cost ratios in order to use available budgets most efficiently.



The benefit-cost analysis introduced could be used to evaluate different types of backup power system for traffic control signals and other ITS applications. In the 2009 *National Manual on Uniform Traffic Control Devices* (MUTCD), only the traffic control signals interconnected with light rail transit systems, which are traffic control signals with railroad preemption or coordinated with flashing-light signal systems, are required to have a backup power source. Despite this, backup power system would be desired at a signalized intersection if the cost-effectiveness was favorable. The backup power system can also protect against electrical surges that can cause damage to traffic controllers and traffic lamps. This protection further reduces the possibility of traffic signal failures.

The traffic-pole-mounted small wind and solar power system can lead to the following benefits:

- Powering traffic lights by on-site renewable energy generation can reduce traffic operation cost.
- By providing backup power, the system can reduce the risk of signal failure in case of catastrophic events.
- The system can utilize existing public right-of-way and roadway infrastructure. The electricity production can be used locally and no extra investment is needed for power distribution system.
- The renewable energy production can reduce air pollution and promote sustainable transportation development.

The availability of renewable resources along roadways limits the implementation of small wind and solar energy systems. Some urban and suburban areas may not have sufficient wind resources to provide efficient wind power generation. In an urban area with many tall buildings, the wind flow may experience turbulence and the sunlight might be shielded, resulting in unstable or insufficient resources for power generation. The presence of trees reduces the efficiency of the wind power production and has an adverse impact on secure operation. Zoning issues present another barrier.

The advances in small wind and solar energy technologies are providing the opportunity to explore possibilities for harnessing renewable energy along roadways. The use of wind and solar energy alternative power can increase the traffic network reliability and promote the development of sustainable transportation systems. Many transportation agencies have committed to investigating strategies for successful implementation of renewable alternative power sources. For example, the study done for the Missouri Department of Transportation identifies the renewable energy sources that could be pursued by the agency in various areas and develops applicable strategies (Grasman et al. 2011). A study for FHWA Office of Real Estate Services presents the findings on the feasibility of implementing renewable energy in the highway right-of-way based on literature review and a series of interviews with stakeholders (Alternative Uses of Highway Right-of-Way. U.S. 2012). The National Cooperative Highway Research Program also provides resources for transportation agencies to use renewable energy as alternative power source (The Louis Berger Group Inc. 2011).

The wind and solar energy projects along roadways raise some new concerns. For solar panels, reflections or glint and these effects' impact on traffic safety would be a concern. Wind turbines along roadways are still novel and more likely to attract attention because of the movement of the turning blades, and thus, the turbines might pose a risk to road users from driving distraction. Distracted driving may result in an increased likelihood of delays and traffic accidents. Transportation agencies should verify that the roadway wind and solar energy project is not adversely affecting highway safety and traffic flow. Integrating renewable energy into highway infrastructures requires adequate liability insurance to hold the agencies harmless (Alternative Uses of Highway Right-of-Way. U.S. 2012). Further research is needed to develop tools that can be easily used for comprehensive project evaluation.

## References

- ACTIVE Corporation. (2008). *Rainbow bridge*. [http://www.sunnypages.jp/travel\\_guide/tokyo\\_leisure/landmarks\\_historical\\_places/Rainbow+Bridge/1799](http://www.sunnypages.jp/travel_guide/tokyo_leisure/landmarks_historical_places/Rainbow+Bridge/1799)
- AWEA. (2011). *Small wind turbine global market study*. Retrieved March 5, 2011, from [http://www.awea.org/learnabout/smallwind/upload/2010\\_AWEA\\_Small\\_Wind\\_Turbine\\_Global\\_Market\\_Study.pdf](http://www.awea.org/learnabout/smallwind/upload/2010_AWEA_Small_Wind_Turbine_Global_Market_Study.pdf)
- Alternative Uses of Highway Right-of-Way. U.S. (2012). *Department of transportation, research and d innovative technology administration, John A. Volpe national transportation systems center, January 2012*.
- American Association of State Highway and Transportation officials. (2003). *User benefits analysis for highways*. Washington, D.C.: AASHTO.
- American Association of State Highway and Transportation officials. (2009). *Standard specifications for structural supports for highway signs, luminaires, and traffic signals* (5th ed.). Washington, D.C.
- Autodesk® Sustainability Workshop. (2013). <http://sustainabilityworkshop.autodesk.com/buildings/wind-analysis-bim>
- Bergey, W. (2001). *Small wind and birds OU letter, 2001*. Retrieved from <http://www.bergey.com/documents/2012/03/small-wind-and-birds-ou-letter.pdf>
- California Energy Commission. (2011). *Senate bill 84 Xx battery backup program for light emitting diode (Led) traffic signals, 2004*. Retrieved January 13, 2011, from [http://www.energy.ca.gov/reports/2004-05-05\\_400-04-006.PDF](http://www.energy.ca.gov/reports/2004-05-05_400-04-006.PDF)
- Canopy Airport Parking. (2010). [http://www.canopyairportparking.com/index.php?option=com\\_content&view=article&id=48&Itemid=2](http://www.canopyairportparking.com/index.php?option=com_content&view=article&id=48&Itemid=2)
- Cobian, R., Henderson, T., Whitlock, M., Sudeshna, N., & Sullivan, E. (2009). *Vehicle emission and level of service standards: Exploratory analysis of the effects of traffic flow on vehicle greenhouse gas emissions*. TRB 88th Annual Meeting Compendium of Papers DVD. Washington, DC.
- Cooler Planet. (2009). *Solar energy to power airports and roadways soon*. <http://solar.coolerplanet.com/News/7310901-solar-energy-to-power-airports-and-roadways-soon.aspx>
- Davis, S. C., Diegel, S. W., & Boundy, R. G. (2013). *Transportation energy data book* (32nd ed.). Oak Ridge, Tennessee: Oak Ridge National Laboratory, U.S. Department of Energy.
- Distributed Wind Energy Association (DWEA). (2010). *Small turbine safety, 2010*. Retrieved from [http://www.distributedwind.org/assets/docs/PandZDocs/dwea\\_safety.pdf](http://www.distributedwind.org/assets/docs/PandZDocs/dwea_safety.pdf)
- Dutton, A. G., Halliday, J. A., & Blanch, M. J. (2002). *The feasibility of building-mounted/integrated wind turbines: Achieving their potential for carbine emission reductions*. UKERC

- research centre, 2002. Retrieved March 5, 2011, from <http://ukerc.rl.ac.uk/cgi-bin/ercr4.pl?GChoose=gdets&GRN=2002-7-28-1-6QString=SearchTerm=buw>
- EIA. (2011). *Annual energy review 2010*. Retrieved November 25, 2011, from <http://www.eia.gov/totalenergy/data/annual/pdf/aer.pdf>
- Energy Digital. (2010). *Italians race on solar powered highway*. [http://www.energydigital.com/news\\_archive/tags/a18-catania-siracusa/italians-race-solar-powered-highway](http://www.energydigital.com/news_archive/tags/a18-catania-siracusa/italians-race-solar-powered-highway)
- FHWA. (1998). *Traffic noise model, 1998*. Retrieved from [http://www.fhwa.dot.gov/environment/noise/traffic\\_noise\\_model/old\\_versions/tnm\\_version\\_10/tech\\_manual/TNM10TechManual.pdf](http://www.fhwa.dot.gov/environment/noise/traffic_noise_model/old_versions/tnm_version_10/tech_manual/TNM10TechManual.pdf)
- FHWA. (2008). *Surrogate safety assessment model, 2008*. Retrieved from <http://www.fhwa.dot.gov/publications/research/safety/08049/>
- Gettman, D., Pu, L., Sayed, T., & Shelby, S. (2008). *Surrogate safety assessment model and validation: Final report* (Publication No. FHWA-HRT-08-051 JUNE).
- Grasman, S., et al. (2011). *Alternative energy sources for MoDOT*. Center for Transportation Infrastructure and Safety, Missouri University of Science and Technology, Report No. NUTC R260.
- Hawaii Department of Transportation. (2009). <http://hawaii.gov/dot/news/new-photovoltaic-power-systems-to-save-taxpayers>
- IPCC. (2011). *IPCC Impacts, adaptation, and vulnerabilities: summary for policymakers, 2007*. Retrieved from June 11, 2011, from <http://www.ipcc.ch/pdf/assessment-report/ar4/wg2/ar4-wg2-spm.pdf>
- Inhabitat. (2008). <http://inhabitat.com/could-solar-freeways-power-our-cities/tullamarine-interchange-tullamarine-solar-power-solar-power-solar-sound-barrier-solar-power-barrier-sound-proof-solar-panels-noise-reduction-solar-barriers-3/>
- International Electrotechnical Commission (IEC). (2005). *Wind turbines—part 12-1: Power performance measurements of electricity producing wind turbines, 2005 (IEC 61400-12-1 ed1.0)*.
- Leo, K. (2013). *South Korean road wirelessly recharges OLEV buses*. *BBC NEWS Technology*, 7 August 2013. Retrieved October 31, 2013, from <http://www.bbc.co.uk/news/technology-23603751>
- Mark V. (2009). *Store pioneers 'revolutionary' green energy system*. 17 June 2009. *The institution of engineering and technology*. Retrieved from November 10, 2010, from <http://kn.theiet.org/news/jun09/store-energy-system.cfm>
- Muller, N. Z., & Mendelsohn, R. (2009). Efficient pollution regulation: Getting the prices right. *American Economics Review*, 99(5), 1714–1739.
- NCDOT. (2009). Northwest North Carolina visitor center/rest area fact sheet. [http://ncdot.org/download/travel/Wilkes\\_visitorcenter\\_factsheet.pdf](http://ncdot.org/download/travel/Wilkes_visitorcenter_factsheet.pdf)
- National Research Council. (2007). *Environmental impacts of wind-energy projects*. Washington, DC.: The National Academies Press.
- Nebraska Legislature. (2010). *Nebraska revised statute 60-6,123*. Retrieved from <http://nebraskalegislature.gov/laws/statutes.php?statute=60-6,123>
- New Energy Technologies. (2010). *New energy's technology for generating electricity from movement of cars tested at Burger King*. [http://www.newenergytechnologiesinc.com/\\_webapp\\_2178554/New\\_Energy%E2%80%99s\\_Technology\\_for\\_Generating\\_Electricity\\_from\\_Movement\\_of\\_Cars\\_Testing\\_at\\_Burger\\_King%C2%AE](http://www.newenergytechnologiesinc.com/_webapp_2178554/New_Energy%E2%80%99s_Technology_for_Generating_Electricity_from_Movement_of_Cars_Testing_at_Burger_King%C2%AE)
- Oregon Office of Innovative Partnerships and Alternative Funding. (2012). Retrieved July 31, 2013, from [http://www.oregon.gov/ODOT/HWY/OIPP/Pages/SLR\\_Baldock.aspx](http://www.oregon.gov/ODOT/HWY/OIPP/Pages/SLR_Baldock.aspx)
- Oregon Office of Innovative Partnerships and Alternative Funding. (2008). Retrieved July 31, 2010, from [http://www.oregon.gov/ODOT/HWY/OIPP/inn\\_solarhighway.shtml](http://www.oregon.gov/ODOT/HWY/OIPP/inn_solarhighway.shtml)
- Ovidiu, S. (2010). *MW solar-powered parking lot opening in Bordentown, NJ*. 2010. <http://www.greenoptimistic.com/2010/01/15/1-mw-solar-powered-parking-lot-opening-in-bordentown-nj/#.UydSFEIOWM8>
- Sarah, A. H. (2011). *MSU extension, and rebecca meadows, wind powering America, national renewable energy lab. Assessing your small wind resource*. Retrieved January 20, 2011, from <http://msuextension.org/publications/HomeHealthandFamily/MT201011HR.pdf>

- Sharma, A., Appiah, & Rosenbaugh, S. (2012). *Assessing the structural, driver and economic impacts of traffic pole mounted wind power generator and solar panel hybrid system*. Mid-America Transportation Center, 2012. Report # MATC\_UNL:420 Final Report25-1121-0001-420.
- Sharman, D. (2010). Getting real about small wind. *Renewable Energy Focus*, 11(1), 30–32.
- Sinha, K. C., & Labi, S. (2007). *Transportation decision making*. New Jersey: John Wiley and Sons.
- Solar Roadways TM. (2010). *Complex cortex designs*. Retrieved from November 10, 2010, from <http://www.solarroadways.com/main.html>
- Speedinfo.com. (2007). <http://www.speedinfo.com/01who/who-page01.html>
- Stankovic, S., Campbell, N., & Harries, A. (2009). *Urban wind energy*. Sterling, VA: Earthscan.
- Suh, N. P., Cho, D. H., & Rim, C. T. (2010). *Design of on-line electric vehicle (OLEV)*. Proceedings of the 20th CIRP Design Conference, Ecole Centrale de Nantes, Nantes, France, April 19–21, 2010.
- TRB. (2010). *Highway capacity manual*. Washington, D.C.: TRB, National Research Council.
- Taek, M. K., Ryan W., & Dan C. (2011). *TDRL projects: Solar/wind hybrid renewable light pole, gravel-road traffic counter, dll-based traffic software development kit*. Retrieved March 2, 2011, from <http://www.its.umn.edu/Publications/ResearchReports/reportdetail.html?id=1670>
- The Green Roadway Project. (2010). *Ocean Tomo*. Retrieved November 10, 2010, from <http://www.thegreenroadway.com>
- The Louis Berger Group Inc. (2011). *Feasibility study of using solar or wind power for transportation infrastructure*. NCHRP 25-25/Task 64 final report, 2011.
- The Bay Net. (2005). *New wind turbine in westminster part of smart, green and growing initiative, 2005*. Retrieved March 7, 2011, from [http://www.thebaynet.com/news/index.cfm/fa/viewstory/story\\_ID/14100](http://www.thebaynet.com/news/index.cfm/fa/viewstory/story_ID/14100)
- Tilahun, N. Y., & Levinson, D. M. (2010). A moment of time: reliability in route choice using stated preference. *Journal of Intelligent Transportation Systems*, 14(3), 179–187.
- Transport for London. (2005). *Green light for new energy efficient bus infrastructure*. <http://www.tfl.gov.uk/static/corporate/media/newscentre/archive/4150.html>
- Wegley, H., Ramsdell, J., Orgill, M., & Drake, R. *A Siting handbook for small wind energy conversion systems*. Report No. PNL-2521 Rev.1. National Technical Information Service, Springfield, VA, 1980.
- Wizelius, T. (2007). *Developing wind power projects: Theory and practice*. Sterling, VA: Earthscan.
- Zhao, M., Sharma, A., Bernt, D. G., Meyer, J. A., Dickey, B., Rosenbaugh, S., et al. (2013). Economic analysis of using a renewable wind power system at a signalized intersection. *Journal of Intelligent Transportation Systems*, 17(3), 1–11

# Chapter 18

## Energy Harvesting from Pavements

Andrew Dawson, Rajib Mallick, Alvaro García Hernandez  
and Pejman Keikhaei Dehdezi

**Abstract** Against a background of the immense solar radiation incident with available pavement surfaces, the opportunity for energy to be harvested from pavements is investigated. While the emphasis is on the harvesting of solar-derived heat energy, some attention is also paid to the collection of energy derived from displacement of the pavement by traffic and to solar energy converted directly to electricity via photovoltaic systems embedded in pavements. Basic theory of heat collection is covered along with a discussion of the relevant thermal properties of pavement materials that affect heat transmission and storage in a pavement. Available technologies for pavement energy harvesting are reviewed and some of their advantages and limitations reviewed. The chapter continues with some descriptions of the ways in which the harvested energy can be stored and then used before ending with sections on evaporative cooling of pavements and system evaluation.

---

**Electronic supplementary material** The online version of this article (doi:[10.1007/978-3-662-44719-2\\_18](https://doi.org/10.1007/978-3-662-44719-2_18)) contains supplementary material, which is available to authorized users.

---

A. Dawson (✉) · A.G. Hernandez  
Nottingham Transportation Engineering Centre, University of Nottingham, Nottingham, UK  
e-mail: [Andrew.dawson@nottingham.ac.uk](mailto:Andrew.dawson@nottingham.ac.uk)

A.G. Hernandez  
e-mail: [alvaro.garcia@nottingham.ac.uk](mailto:alvaro.garcia@nottingham.ac.uk)

R. Mallick  
Department of Civil and Environmental Engineering, Worcester Polytechnic Institute, 100  
Institute Road, Worcester, MA, USA  
e-mail: [rajib@wpi.edu](mailto:rajib@wpi.edu)

P.K. Dehdezi  
URS, Regan Way, Beeston, Nottingham, UK  
e-mail: [Pejman.KeikhaeiDehdezi@urs.com](mailto:Pejman.KeikhaeiDehdezi@urs.com)

## 18.1 Introduction

With the increase in world population and industrialization, there has been a continuous increase in consumption of energy. Therefore, this important question is raised; will fossil energy resources (i.e. coal, oil, and gas) in the future account for the energy needed to survive and develop? Although opinions differ as to when fossil fuels will be depleted, there is no doubt that supplies are limited. Oil, one of the most consumable types of fossil fuels, is being consumed about one million times faster than it was made (Armstrong and Blundell 2007).

In addition, environmental pollution is a serious threat to vegetation, wild life, and human health. Generating energy from fossil fuels increases the level of carbon dioxide into the upper earth atmosphere and causes anthropogenic climate change; an acceleration of the ‘greenhouse effect’ (Armstrong and Blundell 2007). The depletion of oil reserves, the need to arrest global warming, climate change, or ozone layer depletion caused by the combustion of fossil fuels, all mandate new thinking from all those with concerns for the future.

Hence, governments and industries everywhere are striving, more than ever, to capture, harvest and generate energy in every possible way by discovering new potential energy supplies and reservoirs, and developing innovative technologies to extract the energy available from them. In terms of harvesting renewable energy, there is none more researched than solar energy. The two most attractive things about solar energy are that it is an assured source of energy for the foreseeable future, and it is omnipresent on any exposed surface on the earth during daylight hours. To make the capture and harvesting of this energy feasible, the solar radiation needs to be of a minimum intensity for sufficient period of time during the year. While there are many areas of the world that are blessed with such sunshine, harvesting technologies need to be of sufficient surface area to capture a meaningful amount of solar radiation. The most commonly used technology—photovoltaic cells—includes cells that themselves have a significant environmental footprint (estimated energy payback times (energy generated/energy consumed to make and deliver) between 0.7 and 4 years and carbon footprints of between 15 and 38 g CO<sub>2</sub>-equivalent per kWh generated) (de Wild-Scholten 2013).

For these reasons it would be attractive to find an existing common material, existing in all parts of the world, of significant surface area that would be exposed to sunlight all year round and that has the ability to “hold” the energy in the form of “heat” that can be extracted. Pavements—asphalt and concrete, are such materials. They cover millions of square kilometers all over the world and are exposed to the environment throughout the year. As an example, considering the total paved surfaces of 158,000 km<sup>2</sup> in the US, then an average of 4.8 kWh of incident solar radiation per square meter per day means that here are 758 TWh of solar energy per day that is incident on pavements. These pavement surfaces, because of their relatively high absorptivity (and hence low reflectivity) and low conductivity, absorb a significant amount of this radiation (as much as 80–90 % of the energy reaching the earth’s surface—see Fig. 18.1) and then hold it as heat energy. Hot pavement

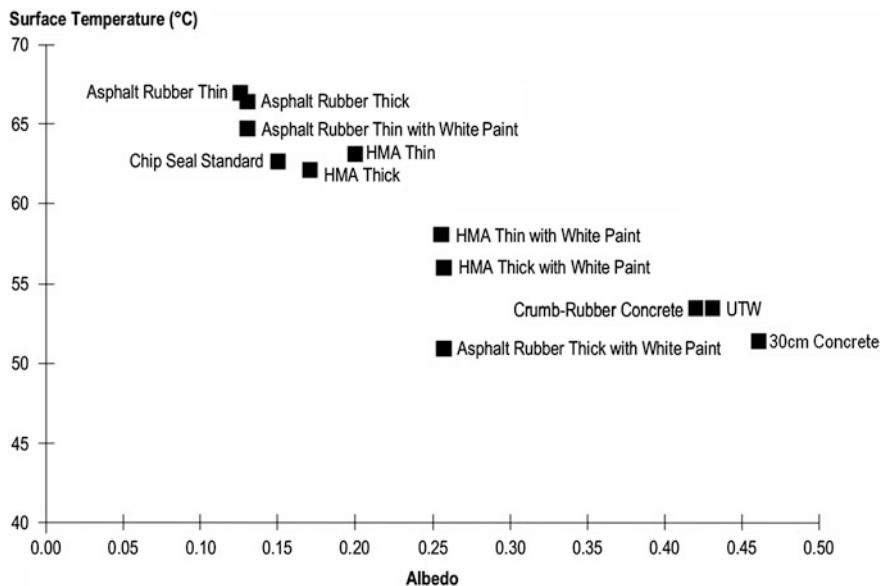

**Fig. 18.1** Albedo for a range of pavement types in Phoenix, AZ (Cambridge Systematics 2005). Notes Albedo is the proportion of incident energy reflected, thus  $100 \times (1 - \text{Albedo})$  gives the percentage absorbed; *HMA* Hot mix asphalt, *UTW* Ultra-thin whitetopping (concrete)

surfaces, especially during warm weather, are common observations in most places of the world and are implicated in contributing to the Urban Heat Island (UHI) effect. Their surfaces emit that stored heat, particularly in evenings, leading to increased temperatures of adjacent buildings, use of more cooling energy, and hence depletion of fossil fuels, with consequent CO<sub>2</sub> and particulate emissions (Wong and Chen 2009). Furthermore, hot pavements are more likely to experience structural and functional failures sooner, thus requiring more frequent maintenance. Moreover, rutting is a major temperature-related distress in asphalt pavements that occurs as a result of high temperature. Hence this heat absorption leads indirectly to greater consumption of natural resources and results in more harmful emissions that contribute towards climate change (Fig. 18.2). Collecting heat from the pavement could reduce the UHI effect and rutting potential of the asphalt pavement (Mallick et al. 2009; Wu et al. 2011).

If this heat energy were to be extracted, two principle benefits would be obtained:

- The energy could be used beneficially, allowing a reduction in fossil fuel-derived energy
- The energy would be removed from the location where it is currently causing a problem (both to the pavement and to the UHI)



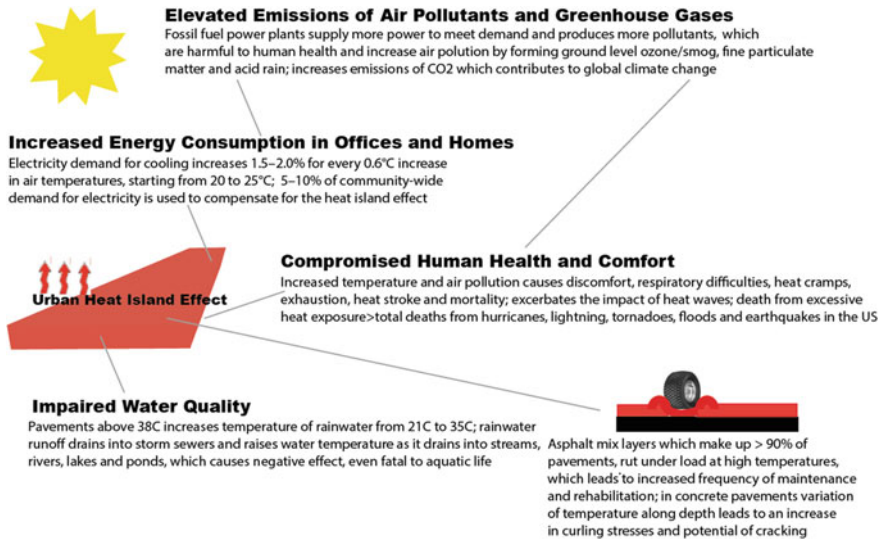

**Fig. 18.2** Effects of high temperature in pavements (James 2002; Akbari 2005)

To give some context to the amount of solar radiation incidence on pavements, 758 TWh as mentioned above, consider that there are a little over 300 million households in the US using, on average, about 30 kWh of energy per day—a total of about 9 TWh. Thus it is apparent that the complete household consumption of energy in the US could be provided from pavements if only 1.2 % of the solar energy incident on the pavement could be captured! Also consider:

1. The fact that there is no need to set up a collector system to capture this energy, (although there is a need for a system to “harvest” it), the system already exists and is functioning as part of the transportation network! Indeed, as Fig. 18.1 shows, pavement surfaces are among materials with low albedo (i.e. they don’t reflect the energy back into the atmosphere well), so they are relatively efficient at energy collection without any special treatment.
2. That no additional material is needed for the solar “collector” and this means an avoidance of a significant amount of energy, money and time that are involved in the manufacturing process.
3. Because the heat is retained inside the pavement, it could be used even at night, when the demand for energy could be significant and maybe even higher than that during the daylight hours.

Due to the nature of solar energy, two components are required in order to have a functional solar energy system; a collector and a storage unit. These are required whether a PV system is considered or, as here, a pavement. In any solar energy system, the collector simply receives the radiation that falls on it and converts it to another form of energy, such as electricity in a PV system, or in the case of a pavement, converts it to heat. The beauty of a pavement solar energy system is that,



properly considered, the pavement not only provides the collector but can also act as an energy storage unit due to its large thermal mass thereby largely overcoming the non-constant nature of the supply of solar energy.

Of course, there are many barriers to practical harvesting, among which are the following:

- consumers of the energy may not be close to the pavement giving energy conveyance problems, particularly in rural areas. A considerable proportion of the 158,000 km<sup>2</sup> of pavement mentioned above will have this problem,
- constructing harvesting arrangements that don't negatively impact the pavement from delivering its primary function, carrying traffic, will not be a trivial issue,
- maintenance of the harvesting arrangements and of the pavement must be achievable without disrupting the other,
- conventional pavement construction sequences, materials and plant may not be best suited to installing energy harvesting equipment,
- in the developed world most pavements are already constructed so harvesting systems would usually need to be retro-fitted and this will probably be difficult/expensive/disruptive,
- initially, the durability of pavements equipped with energy harvesting arrangements won't be understood very well, causing planning difficulties for pavement managers,
- as with all solar systems, the energy abstractable is weather and time-of-day dependent so consumers will almost certainly require an alternative source as well, decreasing economic efficiency.

Nevertheless, in the light of the very significant opportunity, even at low efficiencies, as mentioned above, extraction of heat energy from pavements is very likely to be a worthwhile effort! It might be even more attractive in developing countries where pavement infrastructure is developing rapidly and where energy consumption rates are lower at the moment but increasing rapidly (so demand for new energy sources is extremely strong). Furthermore many of those developing countries are solar-gain-rich.

A few companies have been installing systems for the last decade or so, but, overall, given the barriers listed above, we can anticipate slow take-up of pavement energy harvesting technology. Furthermore there will be need for significant research efforts to address these, and other, barriers. For this reason most experience to date is restricted to academic research, yet research and practical implementation is rapidly growing all over the world!

## 18.2 Energy Incidence with Pavement Surface

As can be seen from Fig. 18.3, approximately, half of the world's incoming solar energy is absorbed by the earth's surface (Russell 2007). Most obviously, the sun provides solar energy to our planet's surface at a rate of about 100,000 TW;

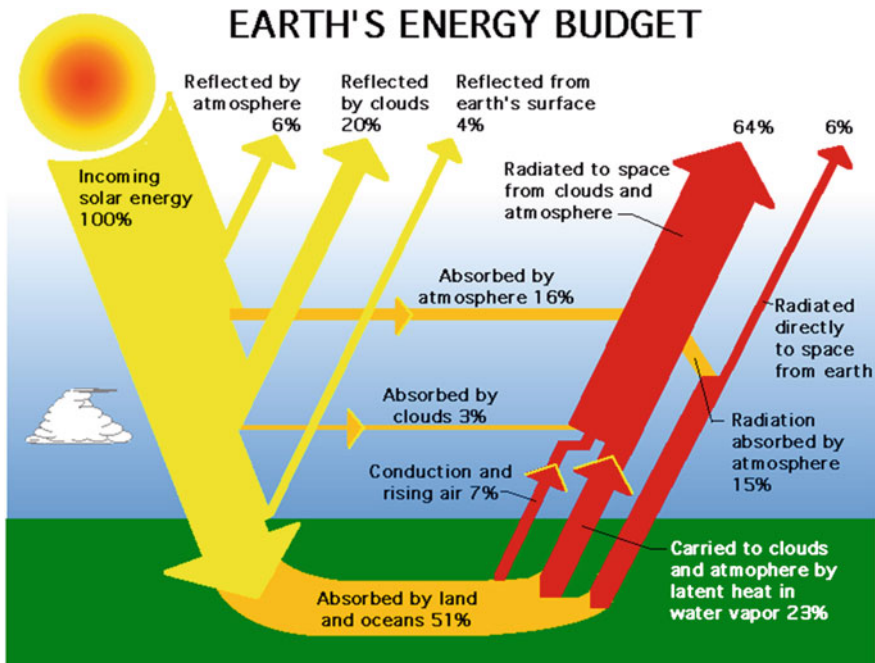

Fig. 18.3 Solar energy budget (NASA 2014)

therefore, the energy from one hour of sunlight is approximately equivalent to all the energy mankind currently uses in a year (Armstrong and Blundell 2007). When this energy is incident with a pavement it, inevitably, heats the pavement. Most likely we have all experienced hot pavement surfaces in the summer months. But what are the factors that control how hot the pavement will get? As Fig. 18.4 shows, the energy balance in pavements involves five factors:

1. Solar radiation (also known as irradiance)
2. Absorption and reflection
3. Conduction
4. Convection, and
5. Thermal radiation.

The pavement absorbs (and partly reflects) the solar radiation. The absorbed heat is partly conducted down through the pavement's layers and partly accumulated in the material. Denser pavements can accumulate more energy than porous pavement (as they almost always have a higher specific heat) and the speed at which an asphalt (or other) mixture loses heat depends on the thermal conductivity of the mixture (a function of the thermal conductivity of its individual compounds). The surface is cooled down by the effect of wind that blows air at lower temperature to the pavement surface, by the infrared radiation emitted to the space by the hot

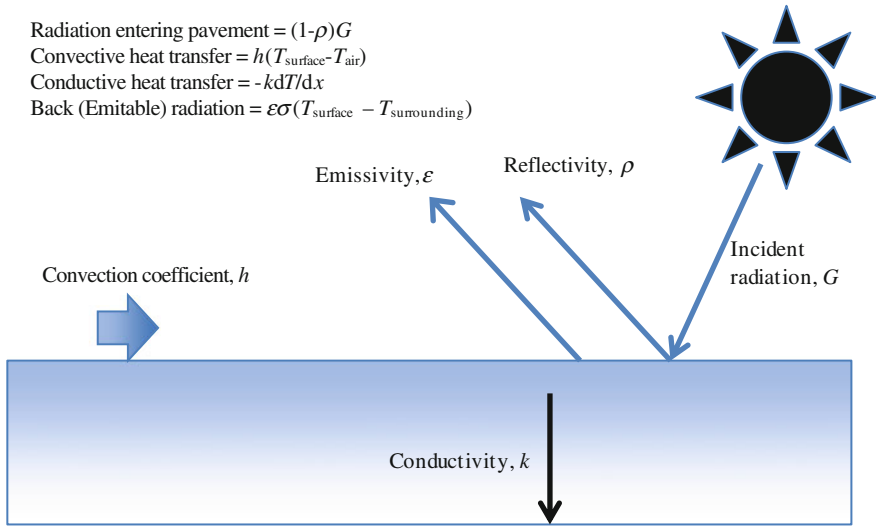

Fig. 18.4 Heat transfer mechanisms in pavements

pavement and by the convective losses that happens when air in contact with the surface of the pavement heats and moves away from the surface (Fig. 18.4).

Porous pavements have greater surface areas in contact with air than dense pavements, and thus will experience higher convective losses. Furthermore, porous pavements may accumulate water moisture, which accelerates the heat losses as it evaporates (see Sect. 18.8). For this reason, porous pavements are recommended to reduce the widely researched Urban Heat Island (UHI) effect, through which the near surface air temperatures in urban areas remain at a higher level than that in rural areas during nighttime.

From this model of energy balance, it is obvious that the greater is the surface absorptivity (and hence the lower is the reflection), and lower is the thermal conductivity to underlying layers, then the greater is the amount of energy that is “captured” and “retained” by the pavement. In general, asphalt pavements, primarily because of their dark surface color, have lower reflectivity (also known as albedo) ( $<0.2$  as shown in Fig. 18.1, indicating that less than 20 % is reflected back) than Portland cement concrete surfaces, which tend to have higher reflectivity ( $\sim 0.4$ —see Fig. 18.1). Therefore, the amount of heat absorbed by an asphalt pavement (or one which as an asphalt mixture surface) is relatively high.

Furthermore, the conductivities of the lower layers of the pavement, which generally consist of aggregate base and/or soil layers, are also relatively low. Therefore, the net effect is the entrapment of heat energy for a significant amount of time—so much so, that a review of temperature profile across the depth of a typical pavement will most likely show a higher temperature at a deeper layer, compared to the surface or near surface layer, at night or just before dawn. It is precisely this “trapping” of heat that leads to progressive rise in temperature in pavements,

particularly, asphalt layers, on successively warm summer days and, hence to their accelerated deterioration. Asphalt is a visco-elastic material such that traffic loading at higher temperatures tends to cause permanent (irrecoverable) deformations which appear to the road user as surface rutting. In addition, higher temperatures mean lower stiffnesses which, in turn, reduce the ability of the upper layers to spread the loading so efficiently and this can lead to over-stressing of lower layers in the pavement thereby reducing pavement life.

### 18.3 Energy Characteristics of Pavement Materials

In summer, the mean temperature of the surface of the pavement increases due to solar radiation. This heating effect, due to the high heat capacity of the pavement materials and underlying rocks and soils, transports energy only slowly downwards into the ground. Therefore, more than a few meters down, the temperature of the subsurface is remarkably stable, at a value approximating to the long-term annual average surface temperature. Figure 18.5 shows the temperature at various depths in the UK for open (unpaved) ground to illustrate this (Banks 2008).

Heat transfer due to conduction—the principal method of heat transfer in a solid—is described by Fourier’s law (Eq. 18.1) for one-dimensional flow (a reasonable approximation for downward heat flow in a pavement):

$$Q_{\text{conduction}} = \lambda A \frac{T_1 - T_2}{\Delta x} = -\lambda A \frac{\Delta T}{\Delta x} \quad (18.1)$$

where

$Q_{\text{conduction}}$  Rate of heat conduction (W)

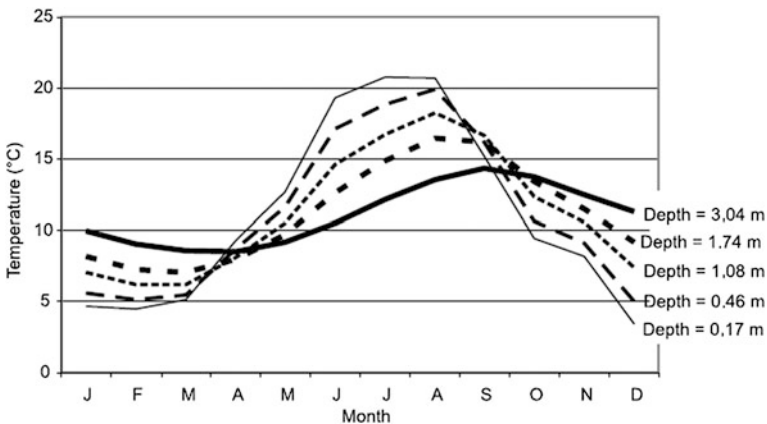

Fig. 18.5 Seasonal temperature fluctuation at various depths in the UK (Banks 2008)

$A$	Surface area ( $m^2$ )
$\lambda$	Thermal conductivity of the material ( $W/m\ ^\circ C$ )
$\Delta T/\Delta x$	Temperature gradient in the direction of heat flow ( $^\circ C/m$ )

Thus the higher the thermal conductivity,  $\lambda$ , of the pavement material, the higher the rate of energy transfer away from a hot pavement surface. If the energy is being abstracted via some kind of embedded heat exchanger, then the thermal conductivity of the pavement material will also be important in determining the arrival of heat at that exchanger. The thermal conductivity of the pavement material will depend on many factors such as; mineral composition, porosity and water content, size, shape, texture, and arrangement of particles and binders. Although the rate of transfer of heat is primarily by heat conduction, it is also achieved to a certain degree by moisture migration (Leong et al. 1998).

Quartz has a thermal conductivity, at around  $8\ W/m\ ^\circ C$ , several times higher than that of other common rock forming minerals (Banks 2008). Thus, the thermal conductivity of materials in the ground can be greatly influenced by their quartz content. The higher the quartz content, the higher the thermal conductivity (Leong et al. 1998; Côté and Konrad 2005; Tarnawski et al. 2009). Thermal conductivities of common pavement material components are presented in Table 18.1.

Moisture content of soil is another important factor that affects the thermal properties of materials in the ground and, consequently, the performance of ground source heat systems (see Sect. 18.7). Ewing and Horton (2007) showed that water between particles can provide thermal bridging across contact points in granular materials, thereby reinforcing the heat transfer ability. Leong et al. (1998) similarly concluded that the average heat extraction, and hence the performance of a ground source system, significantly increases as moisture content and quartz content in soil increase. Côté and Konrad's (2005) data is given in Fig. 18.6 which illustrates these two factors.

**Table 18.1** Dry thermal conductivity of some pavement constituents (Sundberg 1988; Read and Whiteoak 2003; Banks 2008; Busby et al. 2009; Keikhaei Dehdezi 2012) and reference materials

Constituent	Range of thermal conductivity ( $W/m\ ^\circ C$ )
Quartzite	5.5–7.5
Granite	3.0–4.0
Limestone	1.5–3.0
Basalt	1.3–2.3
Copper slag	2.2
Lyttag (lightweight aggregate)	1.0
Bitumen	0.15–0.17
Cement	0.29
Water	0.6
Air	0.024

**Fig. 18.6** Thermal conductivity ( $k$ ) of base-course pavement materials as a function of water content and thermal conductivity ( $k_s$ ) of solid particles (Côté and Konrad 2005)

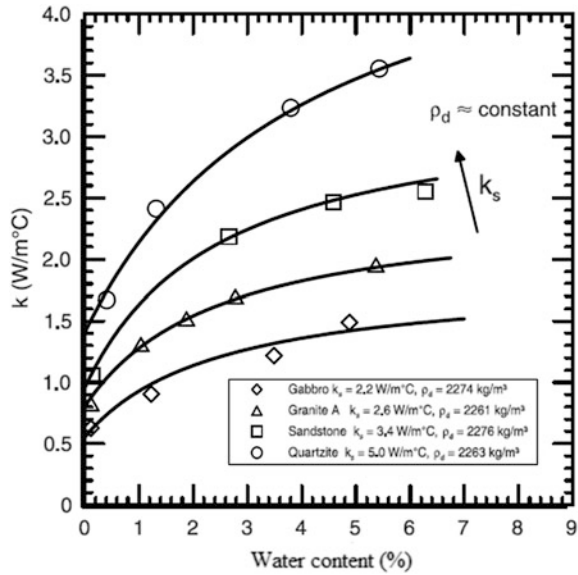

The specific heat capacity of a material is defined as the energy required to raise the temperature of a unit mass of a substance by one degree (Eq. 18.2). It is the chief property affecting a material’s ability to store energy. In addition, a high specific heat capacity will slow energy transmission as it will take more energy to raise the temperature at a point and, thus, more energy is required to develop a particular thermal gradient which drives heat transfer. Some values of specific heat for both conventional and unconventional components of pavement materials are given in Table 18.2.

$$\Delta Q = m \times C_p \times \Delta T \tag{18.2}$$

where

- $\Delta Q$  Heat energy taken in or given out (J)
- $M$  Mass (kg)
- $C_p$  Specific heat capacity (J/kg °C)
- $\Delta T$  Temperature change caused by heat energy in/out (°C)

Keikhaei Dehdezi et al. (2011) investigated the thermo-physical properties of Portland cement concretes by incorporating heavy-weight, light-weight, and normal aggregates, as well as other additives (see Table 18.3). The thermo-physical properties were then used as inputs to a transient heat transport model (refer to Hall et al. 2012, for the model’s details) in order to evaluate the temperature changes at the various depths at which heat might be abstracted or stored. The results indicated that a high diffusivity pavement, e.g. incorporating high conductive aggregates (e.g.

**Table 18.2** Mean values of dry-state specific heat capacity ( $C_p$ ) of pavement components (Max variation of  $\pm 7\%$ ) (Keikhaei Dehdezi 2012)

Components	$C_p$ (J/kg °C)							
	-10 °C	0 °C	7 °C	17 °C	27 °C	37 °C	47 °C	57 °C
Limestone	793	838	859	878	892	904	917	931
Quartzite	609	629	642	659	675	693	709	724
Copper slag	628	670	679	691	701	712	723	734
Natural sand	610	637	655	679	698	711	721	734
Lyttag	620	712	741	767	778	787	799	812
Rubber	1,194	1,292	1,326	1,369	1,406	1,444	1,485	1,523
Hardened cement paste	877	1,021	1,094	1,241	1,458	1,714	1,978	2,300
Ferag	521	552	562	575	586	589	609	618

quartzite) and/or metallic fibers, can significantly enhance heat transfer as well as reduction of thermal stresses across the concrete slab.

Dawson et al. (2012) investigated the desirable mechanical and thermo-physical properties of asphalt concrete pavement materials incorporating different aggregates and additives as well as their effects on the evolution of temperature depth profile (see Table 18.4). They concluded that fully replacing limestone aggregates with quartzite can enhance the thermal conductivity by about 135 %. In addition, the quartzite mixture improved the fatigue performance while showing a negative effect on the stiffness. The addition of copper fibers improved the thermal conductivity slightly, while it offered a significant improvement in the stiffness and fatigue performance. Asphalt concrete containing quartzite aggregate showed the potential to reduce the maximum surface temperature, by up to 4 °C, by transmitting heat away from the surface more rapidly due to the larger conductivity.

In related work, Keikhaei Dehdezi et al. (2012a) experimentally investigated the feasibility of using asphalt pavement as a solar energy collector by installing water-filled copper pipes in two different asphalt mixtures (See Table 18.4). They concluded that asphalt mixture containing quartzite aggregate, due to their higher thermal conductivity, showed a greater ability to collect heat compared to the limestone mixtures. The surface temperature of the quartzite & limestone mix was lowered by  $\sim 13$  and 4 °C respectively when water was circulated through the system. The higher reduction of quartzite pavement surface temperature is as a result of its higher thermal conductivity that facilitates better heat transfer to the water from the pavement materials (see Table 18.3).

The specific heat capacity of a pavement material would, effectively, be greatly enhanced if it contained a phase change material i.e. one that changed from a solid to a liquid when the pavement became heated. Phase change absorbs a significant amount of energy without the temperature increasing. The use of such materials is discussed later in Sect. 18.7.2. Keikhaei Dehdezi (2012) tried these in concretes but

**Table 18.3** Thermal properties of some conventional and experimental pavement concretes (Keikhaei Dehdezi 2012)

Concrete		$\lambda$ (W/m °C)	$\lambda^*$ (W/m °C)	$C_p$ (J/kg °C)	$C_p^*$ (J/kg °C)
Coarse aggregate	Fine aggregate				
Limestone (L)	Natural sand	1.12 ± 0.07	1.36	953	1,114
Quartzite	Natural sand	2.64 ± 0.23	2.81	870	1,031
Quartzite	Quartzite	2.98 ± 0.18	3.08	852	948
Quartzite	Quartzite + 1% Cu_fibre	3.46 ± 0.32	3.84	845	1,026
Copper slag	Natural sand	1.18 ± 0.16	1.42	854	986
Copper slag	Copper slag	0.81 ± 0.15	0.94	837	958
Copper slag	80%C. slag + 20 % rubber	0.64 ± 0.01	0.75	863	995
Copper slag	50%C. slag + 50% rubber	0.57 ± 0.04	0.71	908	1,060
80% L + 20% rubber	Natural sand	0.81 ± 0.14	0.97	987	1,180
50% L + 50% rubber	Natural sand	0.44 ± 0.16	0.61	1,043	1,263
20% L + 80% rubber	Natural sand	0.27	0.40	1,110	1,369
Rubber	Natural sand	0.22	0.36	1,160	1,444
Lyttag	Natural sand	0.94 ± 0.05	1.07	935	1,285
Lyttag	Lyttag	0.46 ± 0.11	0.71	1,009	1,481
Lyttag	Copper slag	0.67 ± 0.09	0.78	900	1,017
Copper slag	Ferag	1.21 ± 0.14	1.31	729	800
Limestone	Limestone	0.92 ± 0.09	1.16	983	1,227
Lyttag	Lyttag	0.59 ± 0.01	0.88	953	1,574
Copper slag	Copper slag	0.84 ± 0.22	0.99	761	880
Quartzite	Quartzite	2.58 ± 0.12	2.91	754	1,040

\* Value of parameter adjusted for condition where pores are water-filled

practical mixing difficulties prevented their successful deployment. Potentially, such modification could be a significant means of storing energy in bound pavement layers at some future date when practical construction issues have been overcome.

The thermal effusivity of a pavement material is a measure of its ability to exchange thermal energy with its surroundings (usually the atmosphere above the



**Table 18.4** Thermal properties of some conventional and experimental pavement asphalts (Keikhaei Dehdezi 2012; Park et al. 2014)

Mix type	$\lambda$ (W/m °C)	$C_p$ (J/kg °C)	$\rho$ (kg/m <sup>3</sup> )
Limestone (L) (control mix)	1.21 ± 0.0	919	2,382
Quartzite (partial replacement of L)	1.46 ± 0.01	880	2,351
Copper slag (partial replacement of L)	1.05 ± 0.01	814	3,088
Quartzite (full replacement of L)	2.47 ± 0.07	870	2,314
Quartzite (full replacement of L) + 2 % Cu-fibre	2.82 ± 0.22	836	2,480
Lyttag (partial replacement of L)	0.46	863	1,504
Alluvial gravel	1.866	1,100	2,276
Alluvial gravel + 10 % graphite (by mass)	1.983	920	2,279
Alluvial gravel + 10 % graphite (by mass)	2.089	810	2,282

pavement is the effusion of concern). A low value is desirable when a user wants a hot pavement to stay hot even when the air temperature drops at night. It is described by Eq. 18.3:

$$e = (\lambda \rho C_p)^{0.5} \quad (18.3)$$

where

- $e$  Thermal effusivity (J/m<sup>2</sup> °C)
- $\lambda$  Thermal conductivity (W/m °C)
- $\rho$  Density of the pavement material (kg/m<sup>3</sup>)
- $C_p$  Specific heat capacity (J/kg °C)

As can be seen from Eq. 18.3, limiting heat loss is aided by reducing thermal conductivity, density and specific heat capacity. Practically, most users will want specific heat capacity to remain high and, apart for phase change materials (see Sect. 18.7.2), this property is closely linked with density. Therefore effusive loss of heat to the atmosphere is often only achieved by reducing thermal conductivity ... but this can be difficult if a high thermal conductivity is wanted to get the energy into the pavement in the first place!

One further thermal property of relevance is thermal diffusivity. It is a measure of a pavement material's ability to conduct thermal energy relative to its ability to store it. Equation 18.4 defines it:

$$\alpha = \lambda / (\rho C_p) \quad (18.4)$$

where  $\alpha$  = thermal diffusivity and  $\lambda$ ,  $\rho$  and  $C_p$  were defined for Eq. 18.3 above. This parameter is a useful comparator of the thermal properties of materials as it allows

one to judge whether the material is better as a conductor than a store and hence different pavement materials may be best placed within a pavement to achieve either storage or energy movement from the surface.

As already mentioned, porosity and moisture are also important pavement material properties as regards thermal response, but these are discussed elsewhere (see Sects. 18.8 and 18.7.2).

## 18.4 Energy Collection and Transmission Techniques

### 18.4.1 Thermal Energy to Buried Water Pipes

The traditional method of extracting heat energy is through the use of a suitable fluid—a cold fluid goes into the system and a hot fluid comes out—which can then be utilized for generation of electricity, for example. Following this traditional approach, pavement engineers have focused on the use of piping networks underneath the surface to carry energy absorbing fluids as the primary mode of energy harvesting from pavements (Fig. 18.7). Figure 18.8 shows an installation of

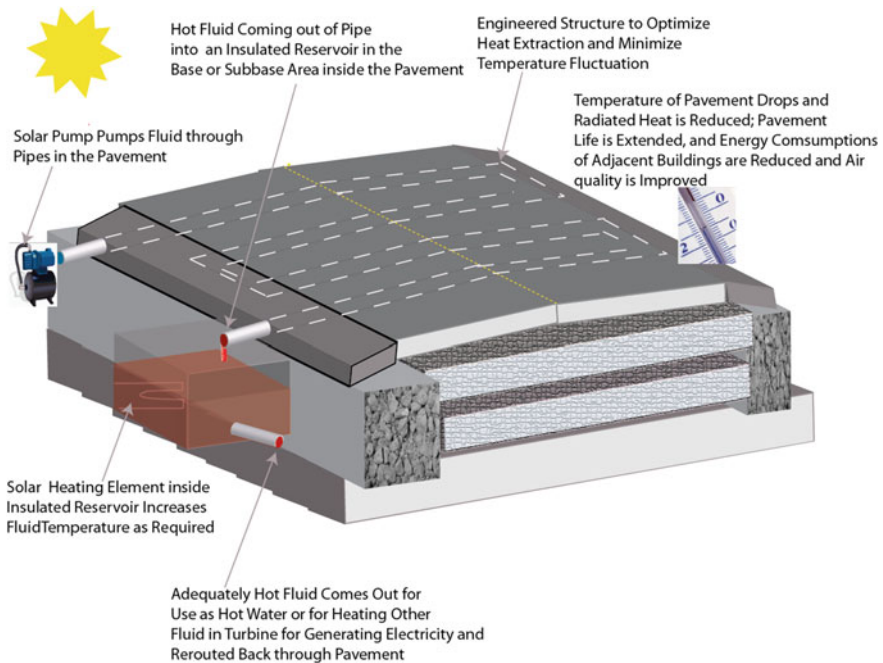

**Fig. 18.7** Concept of heat energy extraction using piping system in pavements (Mallick et al. 2009)



**Fig. 18.8** Asphalt solar collector system under construction on a bridge in Rotterdam (de Bondt 2003)

this type during construction, with the pavement structure being equipped with fluid-filled pipes (known as ‘loops’). The fluid in the pipe can absorb/reject heat to the pavement and deliver useful energy to nearby buildings. The heated water can then be utilized as it is, or be used in conjunction with a heat pump, to produce hot water, in heating applications, or to generate electricity.

The fluid carrying piping system should be of such material, configuration and be located at such a depth, that the most amount of energy can be extracted from any given pavement at a specific geographical location. Therefore, the task of designing and locating the best system to harvest heat energy from pavements becomes essentially one of optimization. However, “optimal” performance will depend on

- climate
- when heat energy abstraction is required (night or day?)
- the criteria included in the optimization (energy output, pavement response, road safety, capital costs, maintenance costs, ultimate recyclability, embodied energy, traffic delays due to installation and maintenance, etc.) and those excluded. This scoping is critical for optimizing the design and for evaluating performance (see Sect. 18.9)
- the person performing the optimization (probably)

**Table 18.5** Examples of factors affecting extraction of heat energy from pavements

System	Component
Location	Materials for fluid and pipe
Depth	Efficiency enhancement options
Area	Dimension and configuration of pipe
Storage option	Fluid flow rate

Note also the fact that this optimization should, at the end, yield a system that would provide the most return out of an investment; the economic “break even” period should be relatively low. The variables that influence this optimization process are listed in Table 18.5, along with their significant influences. Research is being conducted to improve the contribution from each of these variables, as well as from the whole system. One key research question is how to improve the efficiency of heat transfer between the hot pavement layer and the energy capturing medium. This is discussed more in Sect. 18.5.

Key advantages of such systems are as follows:

1. The basic concept is very simple, and its use in paved areas could transform industries’ energy supplies and help in job creation,
2. The marginal cost of the proposed system is significantly lower than traditional solar power harvesting systems,
3. The cost of the optimized system, which basically consists of installation of fluid carrying pipes underneath the surface, can be shared with the transportation project/improvement costs,
4. For buildings adjacent to paved areas, it serves as a local energy source, where power is provided on-site, that avoids the dependence on energy grid, and hence helps in avoiding risks with grid failure, outage or surge or increase in cost,
5. The system can be used in existing pavement areas and hence does not require the purchasing of new real estate,
6. Because pavements remain at relatively high temperature at night (particularly in high temperature regions), this energy source would remain active even after sundown, and can be used as an emergency/backup energy supply system,
7. In conjunction with an appropriate construction and maintenance schedule, the energy harvesting system can be utilized to extend the life of pavements by reducing temperatures to tolerable levels, and
8. The technology will lead to the development of ancillary industries such as for energy capture in high energy need locations (e.g. airports) and for adaptive pavement systems with controllable load carrying capacity.

A first application of pavement solar collectors in the literature seems to be that of Sedgwick and Patrick (1981). They experimentally studied swimming pool heating in summer by use of a grid of plastic pipes laid at 20 mm under an asphalt surface in a tennis court in the UK. The air temperature and solar radiation for the

period of the experiment reached 22 °C and 610 W/m<sup>2</sup>, respectively. They found that the system can provide heating to swimming pools which are usually operated at between 20 and 27 °C, hence, concluded that the system was technically feasible, for UK conditions, and cost effective compared to a conventional swimming pool solar heater. Hasebe et al. (2006) experimentally investigated an asphalt solar collector to produce electric power. The electric power was produced by temperature differences between warm water (coming out of the embedded pipe in the pavement) and cool water (supplied from a river) at a thermoelectric generator. They investigated the effects of outlet temperature of the warm water on generated electricity and found that the output power significantly increases as outlet water temperature increases.

Studies in recent years have aimed to improve the efficiency of pavement heat collector systems. Mallick et al. (2009) experimentally and theoretically studied asphalt pavement for applications of harvesting energy and reducing the UHI effect. They theoretically (using a finite- element model) showed that near-surface air temperature could be reduced as much as 10 °C by running water through the embedded pipes placed at about 40 mm under the pavement. In addition, they performed small-scale laboratory testing on asphalt pavement samples. Their results showed that black acrylic paint on the asphalt surface and replacing limestone aggregates with aggregates containing high percentage of quartz could increase the efficiency (rise in water temperature) of the system by 50 and 100 %, respectively.

### ***18.4.2 Thermal Energy to Buried Air Conduits***

An artificial air flow through the pavement can be created through an air-conducting layer (e.g. porous layer) embedded in the asphalt pavement structure, where air could circulate and be heated up in summer, or cooled down in winter. By connecting these air conduits to an updraft or to a downdraft chimney, temperature differences between the pavement and the environment can be used to create an air flow, which would allow wind turbines to produce energy and would cool the pavement down in summer or heat it up in winter. In urban areas, the chimneys with the wind turbines could be easily integrated in street lightening posts. This concept is explained in detail by Garcia and Partl (2014) (see Fig. 18.9). In this preliminary research, the air flow and the reduction of temperature in the surface were taken as indicators of the energy harvested by the pavement.

The temperature distribution in a pavement results from the complex interplay between the environmental conditions and the thermal properties of the pavement (see Fig. 18.10). The pavement receives short-wave solar radiation (a). A fraction of the incoming radiation is reflected (b). Furthermore, there is a natural convective heat exchange happening between the asphalt concrete surface and the air (c) and the remaining part is absorbed by the pavement material, causing it to heat up. The heat is then distributed across the depth of the pavement by means of (effective)

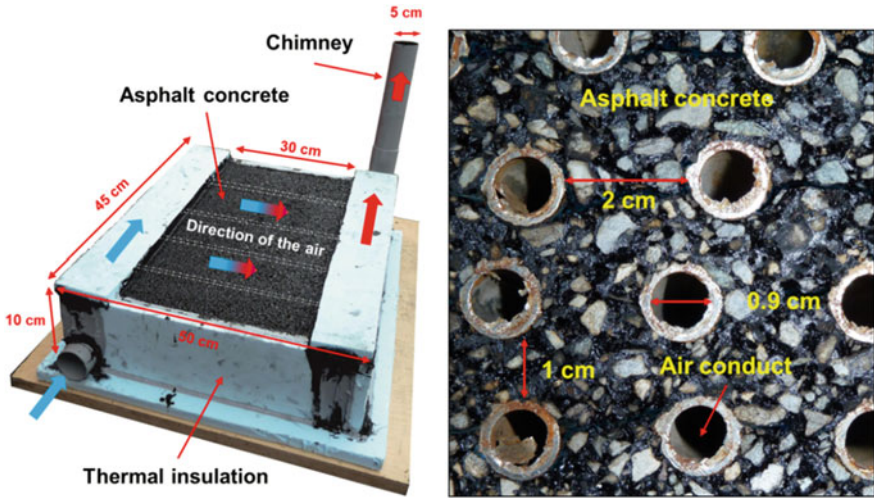

Fig. 18.9 (Left) Scheme of the prototype demonstrator. (Right) Detail of the air conduits in one side of the prototype (Garcia and Partl 2014)

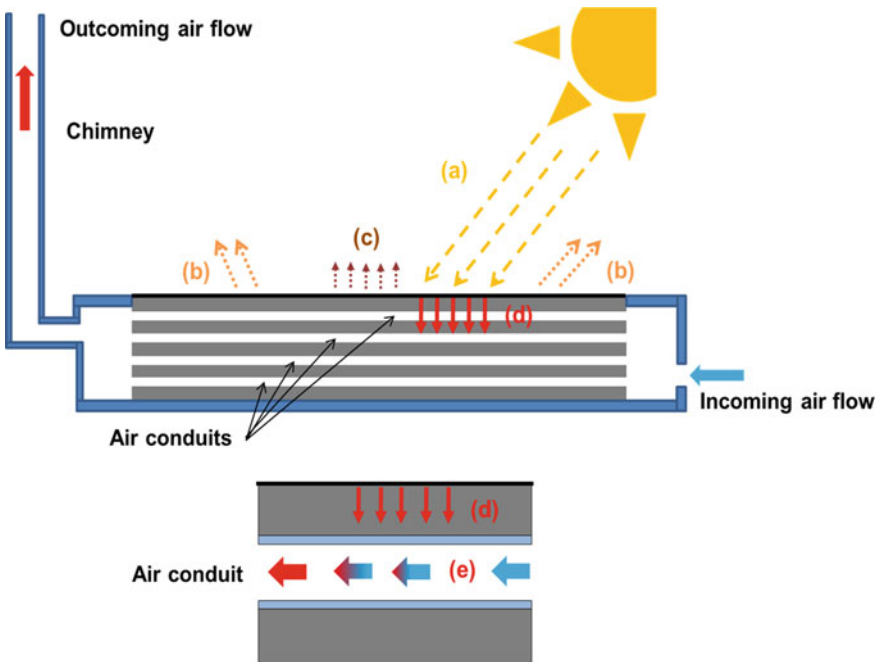

Fig. 18.10 Factors affecting the temperature profile over depth of a pavement



conduction (d). Besides, there is a natural convective heat exchange happening inside the tubes (e).

The movement of air is caused by the difference in the air pressure at the end of the chimney and the air pressure at the entrance of the pavement. When the temperature of the air outside the asphalt concrete pavement is different from the temperature inside the asphalt concrete, a difference of pressure may appear. This difference of pressure depends on the mass of air contained in the asphalt concrete and on the height of the chimney. Additionally, this difference of pressure may be increased every time the top of the chimney is exposed to wind. Moreover, as the flow of air inside the asphalt concrete equals the flow of air in the chimney, the speed of air inside the asphalt concrete is proportional to the air speed in the chimney.

Garcia and Partl (2014) found that the air flow through the chimney increased with the temperature of the asphalt concrete and with the height of the chimney. Moreover, it was observed that the air flow through the asphalt concrete produced a reduction of the surface temperature in the pavement of approximately 10 %. Finally, it was concluded that the efficiency of this energy harvesting prototype for harvesting energy from asphalt concrete was approximately 1 %.

### ***18.4.3 Thermal Energy to Buried Heat Pipes***

Heat pipes are tubes (Fig. 18.11), sealed at both ends, that are lined with a wicking material and part-filled with an evaporable fluid. At the hot end of the pipe, fluid in the wick is evaporated into the space in the center of the pipe and the vapor then moves away from the hot end of the pipe towards the cool end, driven by further evaporation. As it reaches the cool end the vapor cools and begins to condense back to a liquid form and is absorbed by the lining. At the hot end of the pipe the lining is drying whereas at the cool end it is wetting. Therefore the liquid is pulled through the lining back to the hot end and so the process repeats itself. Thus, in a hot pavement there is the potential to draw heat from the pavement to the margins of the road. A significant advantage of heat pipes is that they can be manufactured in almost any shape—including flat plates (albeit with cavities inside to act as the ‘pipe’), so it should be possible to routinely install in conventional pavements with appropriate development work.

In normal operations the heat pipe acts like a refrigerator, cooling the end embedded in the pavement and delivering heat energy for (e.g.) space heating. Of course, in cold weather, heat can be provided at the pavement margin to the pipe thereby reversing the energy flow and warming the pavement (e.g. to counteract icing) (Lund 2002). To date, almost all uses have been in this pavement heating application, often using deep ground heat to warm bridge deck pavements in winter months so as to remove ice (Fig. 18.12). In the figure, the heating (sic) pipes convey heat from the evaporator to the bridge deck, the condensing end of the heat pipes being thermally connected to the evaporator of the primary, heat pump loop, but

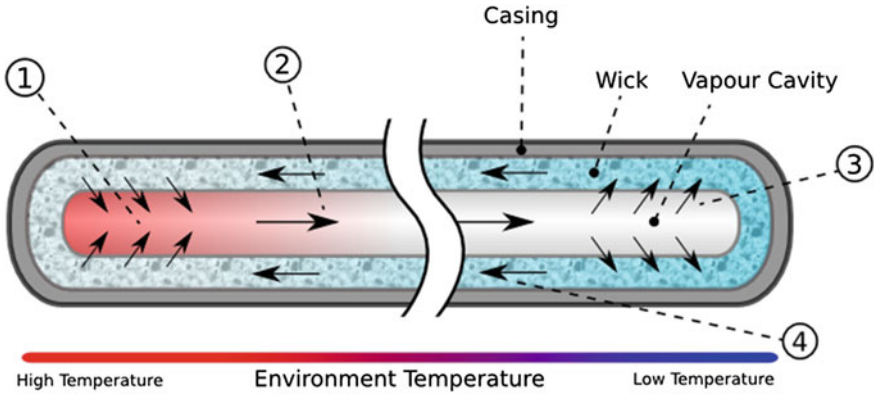

**Heat pipe thermal cycle**

- 1) Working fluid evaporates to vapour absorbing thermal energy.
- 2) Vapour migrates along cavity to lower temperature end.
- 3) Vapour condenses back to fluid and is absorbed by the wick, releasing thermal energy
- 4) Working fluid flows back to higher temperature end.

Fig. 18.11 Concept of a heat pipe (Wikipedia)

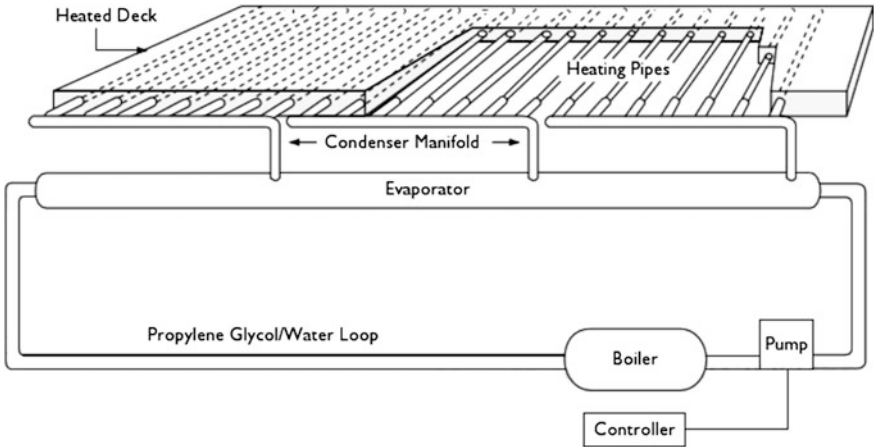

Fig. 18.12 Heat pipe installation to remove ice from bridge decks (McGlen et al. 2006)

between these there is no fluid connection. A list of literature on this application and links to case histories of heat pipes being used in this way are available at the Oklahoma State University “SmartBridge” web-site (OKState 2002).

The device exploits the latent heat of the fluid to draw heat away from the hot end and to hold it in the gas phase until the fluid is condensed at the cool end of the heat pipe. It, thus, has the potential to be far more efficient than the heat exchanger



concept exploited by conventional water (or other fluid) filled pipes. However, the pipe must be tuned to the particular conditions anticipated. Choice of pipe material, size and coolant will all affect the optimal temperature at which it will function. If the temperature becomes large and all the fluid is vaporized, even at the relatively cool end, then there will be very little heat transfer except by slow convection in the gas filling and conduction in the outer skin of the pipe. But if optimized to its application, a heat pipe can be greater than 100 times more efficient at moving heat than solid copper of the same outer dimensions.

#### ***18.4.4 Photovoltaic Pavement Surfaces***

Photovoltaic (PV) pavement surfaces aim to convert solar light into electrical energy through the replacement of pavement structural surfaces with solar road panels. Each individual panel consists of three basic layers: Road Surface Layer, Electronics layer, and Base Plate Layer. The road surface layer provides the strength to protect the electronic layers beneath it, works as water proof layer, and let the sunlight passes through. The electronics layer collects the light that passes the first layer and transforms it into electricity. The base plate layer distributes the power that collected from the electronics layer. In addition, it can also work as a water proof layer for the electronic layer (Botts and Mouw 2013). At the moment of writing this text (April, 2014), the first world's first walkable solar panel pathway has been built at the George Washington University (Inhabit 2013).

Solar Roadways (<http://www.solarroadways.com>) are, at the time of writing, beginning to commercialize hexagonal shaped PV paving slabs that include LED and heating elements. Piezo-electric generation is proposed for future versions. In the future, these are intended to be 'smart' and addressable so that (for example) the LED's could automatically redefine lanes around a broken down vehicle.

#### ***18.4.5 Piezo-Electric and Displacement Power Generation by Foot or Wheel***

It is possible to generate electricity from tiny vertical deformations in the pavement, caused by the movement of vehicles and pedestrians. With this purpose, piezo-electric elements can be embedded in the road structure. Piezoelectric materials generate a voltage when they are subjected to mechanical stress or vibration.

Examples of application are the Pavegen, Innovatech or the Waynergy systems (Pavegen 2012; Waydip 2012; Duarte et al. 2013), which capture kinetic energy from footsteps and vehicle movements and convert it into electrical energy. These systems consist of pavement blocks, with piezoelectric elements embedded. The blocks can be built in different dimensions and they can be applied to indoor or outdoor pavements.



**Fig. 18.13** Pavegen: kinetic energy generation from footsteps (Pavegen 2012)

Each time a person steps on a Pavegen slab (Fig. 18.13), it registers a slight displacement on the vertical axis (up to 5 mm), which is enough to generate electrical energy (Lopes-Ferreira 2012). These blocks can be applied on urban pavements where large numbers of people can generate electrical energy to be used for pedestrian lighting, way-finding solutions, public illumination outdoor advertising, traffic lights, electrical device supply and so on. The top surface of the pavement block is made from 100 % recycled tire rubber and the base is constructed from over 80 % recycled materials. The blocks are waterproof to allow them to operate efficiently in both internal and external environments. Ideal locations to apply these blocks include busy streets, transport hubs, busy train stations, offices, events, schools, shopping centers, pedestrian crossings and so on (Lopes-Ferreira 2012).

Speed control bumps can also be made to deform under normal road traffic. Piezo electric systems can be made to operate in the same way as under foot traffic, but the greater available forces provided by vehicle traffic allows operation of pistons or lever that operate mechano-electrical generators to be contemplated. However, the inclusion of mechanical systems under a pavement is not attractive from a maintenance point-of-view.

#### ***18.4.6 Comparison of Techniques and Practical Issues***

Table 18.6 gives a somewhat subjective summary of the issues associated with the variety of technologies reviewed in this section.

**Table 18.6** Comparative overview of technologies available to harvest energy from pavements

Technology	Purpose	“Efficiency”	Readiness
Water pipes connected to ground source heat system	De-icing	Medium–high	High
Water pipes connected to energy upgrading system	Energy harvesting for adjacent buildings	Medium–high	Medium–high
Buried air conduits	Energy harvesting	Medium–high	Low
Heat pipes connected to ground source heat systems	De-icing	High	Medium–high
Heat pipes connected to energy upgrading systems	Energy harvesting for adjacent buildings	Low–high	Low–medium
Photovoltaic	Energy harvesting for adjacent buildings & signing	Medium–high	Medium–high
Piezo electric	Signing and local LED lighting	Medium	Medium
Piston/lever systems operated from pads	Energy harvesting for highway uses	Low	Low

“Efficiency” is used in this table as a loose descriptor of benefit/cost

## 18.5 Construction Issues

Pavements are constructed to provide functional surfaces for safe and comfortable driving, and transporting freight. Each layer in a pavement has a specific function that contributes to the performance of the entire pavement system. An insertion of a heat energy harvesting system within these layer(s) is obviously a disturbance to the system, and the goal of the designer is to minimize such disturbance or reduce the effect to such a level that it is not detrimental to the performance of the pavement. The system should not interfere with the maintenance activities (that are done on a relatively frequent basis) of the pavement. Furthermore, the system should be protected properly during the construction of layers above it. The significant factors that need to be considered include the type of pavement materials, components of the system, sequence and speed of construction.

The more invasive forms of pavement maintenance include milling of old surfaces, overlaying and trenching. Milling of surfaces removes the top layer (maybe cracked or rutted), almost invariably replacing it with a new layer. Known as inlaying (or, colloquially, “mill and fill”), any embedded heat collection system should be unaffected, provided that it is placed below the depth of maximum milling. All pavement layers can be expected to deform and crack under trafficking and environmental effects, so collection arrays must be robust enough to withstand small tensile, compressive and bending strains and cracks.

Simple overlays, another common pavement remediation technique, are likely to reduce the thermal efficiency of a collection system as the collection of energy will be further from the source, thereby meaning a longer time interval between sun and heat abstraction and lower peak temperatures at the collection level. Therefore

maintenance of pavements incorporating a buried energy harvesting system will need to be adapted from that currently employed and inlaying will, generally, be preferred to overlaying.

In urban areas—the areas most likely to be attractive for energy harvesting—utility services are frequently buried beneath the pavement surface and, from time-to-time, need remedial work. Therefore it would be most imprudent to place buried energy collection arrays over the top of utility lines. This may be quite restrictive and will tend to mean that pavement energy harvesting systems would be better placed in parking areas (though not in the positions that will be covered for long periods by parked vehicles!).

Apart from the selection of appropriate paving materials (see Sect. 18.3) there are two other key construction issues for the installation of heat transfer arrays in pavements. The first concerns connections—these will need to be accessible at the edge of the pavement so there will need to be differences to kerb/ditch arrangements in order that maintenance of the array can be achieved and so that necessary pumping and ancillary equipment can be housed at an optimal position.

The second issue concerns the contact between pipework installations and the surrounding paving materials. Being particulate, when the pavement materials are compacted around pipe arrays a voidy structure tends to be created adjacent to the pipe walls (Keikhaei Dehdezi 2012). This introduces considerable insulation between the pipe and the paving material, reducing the efficiency with which heat is transferred from one to the other. To overcome this some form of grouting might be considered or a fine mix (e.g. mastic asphalt) might be used immediately around the pipe inclusions. Perhaps fins might be appropriate on pipes in order to increase the effective area of contact (and, hence, the energy transfer between the pipe and paving material).

The above comments refer almost exclusively to buried heat arrays, whether fluid-filled pipes or heat pipes. For surface-mounted PV or piezo-electric systems removal and reinstallation during maintenance (or trenching to access buried utility services) may be possible, but most will require very stable layers beneath them. For example, most PVs have glass covers and brittle substrates. Therefore installation on concrete, or as (in effect) block paving, will almost certainly be required.

In developed countries the pavement network is mature and, although further pavement construction and reconstruction into which energy harvesting systems can be installed is certain to feature, retrofitting of harvesting systems into existing pavements is likely, also, to be important. The ways to achieve this are less clear. For PV and piezo-based systems that are installed at the surface, only a certain amount of surface preparation may be required, but heat exchanger installation may require grooves to be cut deep into the surface of a road or car park and this may limit the economics of retrofitting. Another concept is to construct and install some kind of preformed overly that contains a heat exchanger at its lower edge. However, these are hardly more than ideas at the time of writing. The opportunity for retrofitting is large, but the issues to be overcome before efficient and workable techniques are available are many.

## 18.6 Use of Energy Collected

Energy collected in the pavement almost directly in the form of electricity can either be carried away by wires to the point of use or, for piezo and other ultra-low power systems, will be used locally in, e.g. signage and low-power LED lighting arrangements.

The larger quantities of heat energy extracted from pavements, can be utilized in different ways, and innovative application of this relatively low level heat energy is an area of ongoing research. At present, the feasible applications include

- absorption and adsorption chillers for air-conditioning,
- heating of domestic and commercial buildings (though this purpose will probably require heat storage as there may be limited solar energy available at the time when heating is most needed (night and winter)),
- production of hot water for domestic, commercial and industrial purposes,
- water purification, e.g. thermal desalination.

The use of heat in absorption chillers is explained in Fig. 18.14. Note that an economizer/heat exchanger can be added between the pump and the generator. The rectifier is required in low temperature systems like ammonia/water to remove ice crystals. The evaporator draws out the cooling load from cooling space.

Such systems have a number of advantages, including the fact that generally areas that need air conditioning are also areas that are blessed with a significant amount of solar radiation. The potential of application would increase significantly with an increased efficiency of heat capture, such as through the use of heat pipes. However, as in any other engineering applications, the cost of such setups must be justified through the benefits, and hence a rational approach in evaluating the total benefits of a heat capture system in pavements is very much needed.

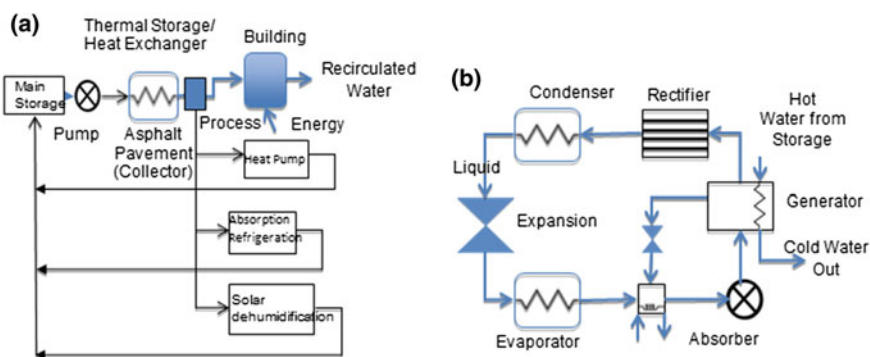

**Fig. 18.14** a Schematic of possible utilization of extracted heat for a building establishment. b A typical absorption chiller/refrigeration system which would be used at the point indicated by the “process” box in a (Mallick and Bhowmick 2013)

Depending on the application, it may be necessary to install an energy storage system along with the energy capture system, probably deeper beneath the pavement surface. This may take a similar form of heat transfer array as used near the surface to collect energy although, with energy upgrading through the use of (e.g.) a heat pump, the temperature of the fluid in the exchanger may be rather higher than the fluid in the collection array. Energy storage is discussed further in the next section.

## 18.7 Storage of Energy in Pavements

### 18.7.1 *In Ground and Groundwater*

The idea of thermal storage dates back to ancient civilization. In 400 BC, Persian engineers had mastered the technique of ice storage in the middle of summer in the desert. They recognized that the ground at depth is significantly cooler than the air during spring and summer and could be used to slow down the rate at which the ice melted. Therefore, in winter the ice was brought from nearby mountains and stored in a specially designed, passively cooled refrigerator, called a yakhchal (meaning: ice store) (Fig. 18.15).

Pavements, by installing loops at shallower depths, might also be used as a heat source during winter and as a heat sink during summer (a similar application to ground source heat pump). A 'Pavement Source Heat Store' (PSHS) would exploit the fact that the seasonal temperature variation under the pavement is much less than the temperature fluctuation of ambient air because of the high thermal mass of the pavement.

In summer, the surface of the earth heats up due to solar radiation. This heating effect, due to the high heat capacity of rocks and soils, moves slowly in the ground. Therefore, below a few meters depth, the temperature of the subsurface is remarkably stable, at a value approximating to the long-term annual average surface temperature. Figure 18.5, which is an example for typical UK ground temperature variations, shows that annual temperature cyclic variations reduce as the depth into the ground increases and the peak becomes offset due to the slow movement of heat through the ground.

The use of rocks and soils in the subsurface as a huge thermal energy storage system allows the storing of solar energy and other surplus heat (e.g. heat loss from a building, discharged heat via water to the sewers, etc.) until a time when they are needed. In other words, the ground can be manipulated as a heat store; it can preserve summer heat until winter and winter cold until summer. Loops are installed underground to extract heat during winter (i.e. underground temperature, in winter, is higher than ambient air) or reject heat during summer (i.e. underground temperature, in summer, is lower than ambient air). The transmitted heat to



**Fig. 18.15** A yakhchal (ice house) in ancient Persia, a place to store ice in summer

buildings can be used, either directly or in conjunction with a heat pump which is a device to transfer heat from a low temperature to a high temperature using mechanical work.

Road Energy Systems® (RES) is a system for extracting energy from asphalt pavements. This system have been developed and partly commercialized in the Netherlands by Ooms Avenhorn Holding bv (de Bondt 2003; Sullivan et al. 2007). The RES works as follows; in summer, cold water from an aquifer is pumped up and circulated through plastic pipes buried in the upper layer of asphalt pavement. Due to the effect of the sun, the water gets warm and the warm water is then transported into another underground reservoir and held at this location until required. In winter, the system works in the opposite way (the stored heat flows from the hot storage medium to the asphalt pavement). The system has the potential of cooling the pavement in summer, which can reduce the deformation of asphalt (rutting), and heating the pavement in winter, which can eliminate icy driving conditions (de Bondt 2003). The system is also linked with a heat pump to provide heating and cooling for adjacent buildings (see Fig. 18.16).

Another major instrumented trial of the solar energy harvesting from pavements was undertaken by Icax™ Limited (Carder et al. 2007) in the UK. The Icax system is very similar to the Ooms system since both of the systems can be considered as ‘hybrid systems’ (collect the solar energy and store it until required). In the Icax system heat, absorbed by the asphalt pavement, is collected through upper loops installed below the asphalt surface. The warm water in the upper loops will then be circulated and stored through lower loops installed below the asphalt surface (see Fig. 18.17) which, unlike the Ooms system, are closed loops (not open at depth to the groundwater). Carder et al. (2007) found that at the end of a full season of heat recovery (from May to September), ground temperature in the center of the heat



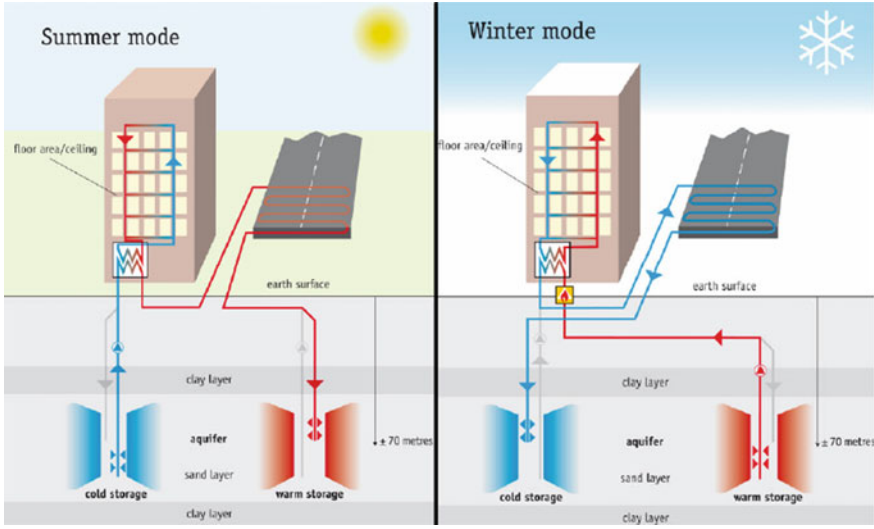

Fig. 18.16 Road energy system innovated by Ooms Avenhorn Holding bv (de Bondt 2003)

store remained about 9 °C higher than that of the control area of the pavement (i.e. without any loops and insulation). Moreover, they carried out winter maintenance of the pavement from the heat recovered in the heat store. They found that the heated section of the road was maintained at a temperature about 3 °C hotter than the unheated area.

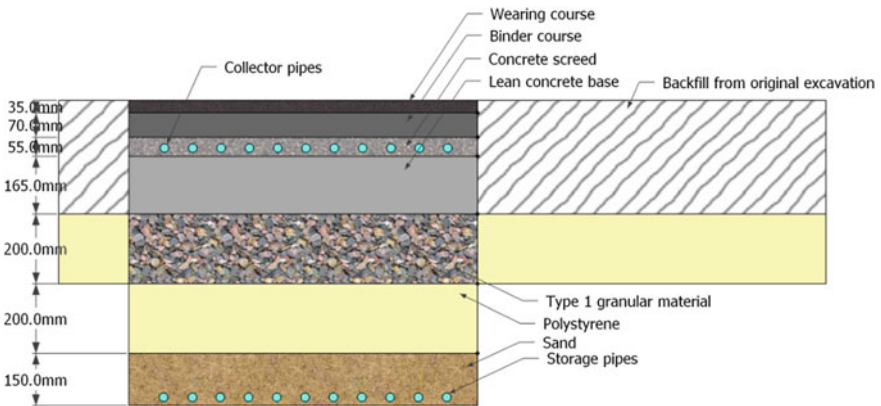

Fig. 18.17 Cross-section of collector and storage loops in the Icax system, Adapted from Carder et al. (2007)



### 18.7.2 Energy Storage Using Phase Change Materials

Physical thermal energy storage technologies can be divided into two categories; sensible and latent (Mehling and Cabeza 2008). Sensible heat storage is by far the most common method for heat storage, which is by changing the temperature of a storage material (see Fig. 18.18), for example high-grade heat storage (e.g. hot water, steam) or low-grade GSHP system described in previous sections. However, heat may also be absorbed, stored or released from a material at an almost constant temperature (see Fig. 18.18) when the high latent heat of solid-liquid phase change, or of liquid-vapor phase change, is exploited.

Phase Change Materials (PCMs) are substances with a high ‘latent heat’,  $H_{melt}$  (i.e. heat of fusion) at a certain temperature (e.g. ‘melting point’,  $T_{melt}$ ). They are capable of storing and releasing large amounts of energy at a narrow characteristic temperature which can be selected to suit operating temperatures in any particular engineering application.

Table 18.7 gives a comparison between typical storage densities of different energy storage methods. As Table 18.7 shows, PCM can store about 2–4 times more heat per volume than is stored as sensible heat in liquids or solids over a temperature interval of 20 °C.

**Fig. 18.18** Sensible and latent heat storage, Adapted from Mehling and Cabeza (2008)

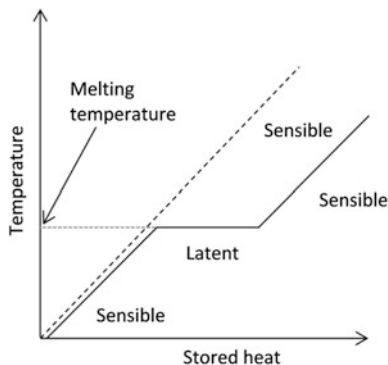

**Table 18.7** Comparison of typical storage densities of different energy storage methods, Adapted from Mehling and Cabeza (2008)

Material	Sensible heat (kJ/kg)	Latent heat (kJ/kg)	Temperature (°C)
Granite (density ~2,650 kg/m <sup>3</sup> )	17	–	$\Delta T = 20\text{ °C}$
Water (density ~1,000 kg/m <sup>3</sup> )	84	330	$\Delta T = 20\text{ °C}$ $T_{melt} = 0\text{ °C}$
Paraffin (density ~900 kg/m <sup>3</sup> )	–	~200	$T_{melt} = 5\text{--}130\text{ °C}$

Potential applications for PCMs include stabilization of temperature as well as storage and supply of heat at relatively small temperature differentials. PCMs have been in use for many years, from their use in the transport of food, beverages, medicine and electronic equipment (Mehling and Cabeza 2008), to being used as thermo regulators in textiles (Sánchez et al. 2010). PCMs have been considered for thermal storage and temperature regulation in building materials since before 1980. They can be impregnated into gypsum wallboards (Athienitis et al. 1997), and concrete (Hunger et al. 2009; Entrop et al. 2011).

PCMs need, in most cases, to be encapsulated in order to hold the liquid phase of PCM and to avoid contact of the PCM with the environment. Encapsulations are usually classified by their size into macro- and microencapsulation. Macro encapsulation means filling the PCM in a macroscopic containment that fit amounts from several ml up to several liters. Microencapsulation is the encapsulation of solid or liquid particles of 1–1000  $\mu\text{m}$  diameter with a solid shell, which can either be in bulk powder form or in colloidal suspension.

Bentz and Turpin (2007) proposed the idea of using PCM-modified concrete to reduce the number of freeze/thaw cycles in concrete bridge decks. They showed, by numerical simulations, that 15wt.% microencapsulated PCM-modified concrete ( $H_{\text{melt}} = 250 \text{ kJ/kg}$ ,  $T_{\text{melt}} = 5 \text{ }^\circ\text{C}$ ) could potentially reduce the number of freeze/thaw cycles by up to  $\sim 30 \%$  compared to a plain concrete (control). Keikhaei Dehdezi et al. (2012c) studied the thermal, mechanical and microstructural aspects of concrete containing different amounts of microencapsulated phase change materials (PCMs). In addition, they carried out numerical simulation to study the potential application of PCM-modified concrete for reduction in summer surface temperature. They have concluded that increasing PCM content in concrete led to lower thermal conductivity and an increase in the heat storage ability of concrete. The result of numerical simulation revealed that reduction in summer concrete pavement surface temperature by several degrees was possible, with implications for reduction in concrete thermal stresses, shrinkage and the Urban Heat Island (UHI) effect. However, the compressive and flexural strength of concrete significantly decreased. Microstructural analysis showed that PCMs appear to remain intact during mixing; however, PCM particles appear to fail by bursting under loading, creating hemispherical voids and crack initiation points as well as possible entrapped air behavior.

Bo et al. (2011) and Ma et al. (2010) investigated the use of PCMs in asphalt. Ma et al. monitored different heat and cooling behaviors as a consequence of the PCM content but didn't report the differences in thermal conductivity and heat capacity. However they do report the change in physical asphalt properties and, for the PCM that they used, were able to measure changes in the mechanical properties as evaluated via Marshall testing. On the other hand Bo et al. (2011) did measure thermal conductivity and specific heat capacity. In their experiments they added PCMs up to 50 % of the mass of the binder although some of the added material was a  $\text{SiO}_2$  carrier. The thermal conductivity rose from 1.3 to 2.5  $\text{W/m }^\circ\text{C}$  while the heat capacity increased by more than 50 % when transitioning the melting temperature of the PCM, even though the added volume was small.

Keikhaei Dehdezi et al. (2012b) investigated soil modification with Phase Change Materials (PCM) in order to enhance its thermo-physical properties and energy storage in the ground. They have concluded that increasing the PCM amount in soil leads to lower thermal conductivity and increase of volumetric heat capacity of PCM-modified soil across the PCM melting temperature range. A  $\Delta T$  of  $>37$  °C is needed to store 25.8 kJ/kg energy in conventional soil, for example, whilst the same amount of energy can be stored in the 40 % PCM-modified soil with a  $\Delta T$  of only 5 °C. In addition, the result of numerical simulation revealed that temperature variation under PCM-modified soil can be reduced by up to 3 °C compared to conventional soil which could improve the coefficient of performance of a heat pump system by more than 17 %.

## 18.8 Direct Pavement Cooling Using Evaporating Water

The principle of phase change is, however, also a key feature of pavement cooling using water. If a porous pavement surface (e.g. porous asphalt) is filled with water and solar gain causes that water to evaporate, then the pavement will be significantly cooled due to the enthalpy of vaporization (latent heat of evaporation). This is a key technique to be considered in reducing the Urban Heat Island effect and one reason why water sprays are frequently used on urban pavements in hot countries.

Takebayashi and Moriyama (2012) performed a heat budget for the summer behavior of sixteen experimental pavements built some years earlier. Four of the pavements were asphalt-surfaced (and three of these had a porosity of 13.6 %); four were Portland cement concrete-surfaced with three of these having a 20 % porosity. The other pavements included blocks, soil and grass. While the air temperature during the three continuous days of the study varied between 26 and 33 °C, pavement surface temperature varied between 26 and 57 °C. Figure 18.19 shows their computations of energy flux for the different pavements. Of course, for a non-porous pavement we can expect the evaporative flux to be almost zero as the materials will not be able to convey water to the surface for evaporation.

It is evident from this data (and others like it) that it will be difficult to achieve the levels of heat loss that characterize grass or trees, but that porous pavements do have the ability to achieve levels that approach 40 % of that achieved by grass. One challenge is to provide the water at a slow rate suitable for evaporation during the day (and less when evaporation slows due to lack of sun). The other is to design asphaltic or Portland Cement Concrete materials that are durable despite the high porosity and water that are contained within them which could give rise to debonding of aggregate from the binder.

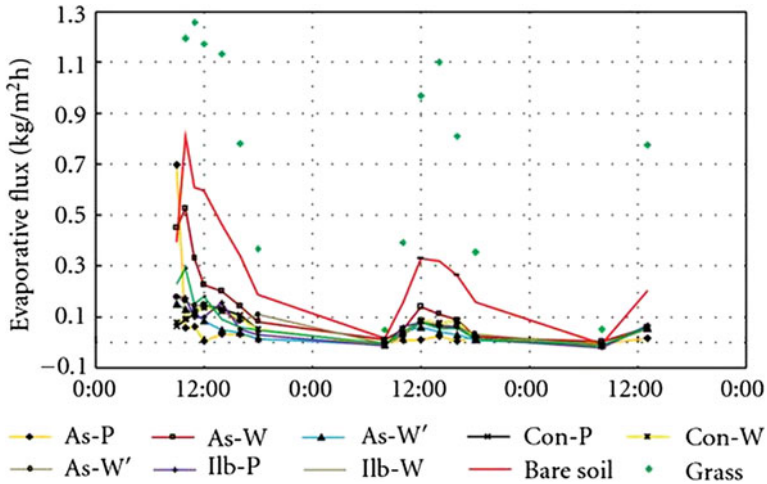

**Fig. 18.19** Evaporative flux for some experimental pavements (Takebayashi and Moriyama 2012). Note *As* Asphalt, *Con* Portland Cement Concrete, *Ilb* Concrete Block, *P* Porous, *W* Porous with Water Retaining Agent A, *W'* Porous with Water Retaining Agent B

## 18.9 Evaluation of Usefulness/Value

The subject of economic feasibility of harvesting heat energy from pavements has been discussed with examples in Mallick et al. (2011) through the use of a spreadsheet (available for download at <http://link.springer.com/> using the doi:10.1007/978-3-662-44719-2\_18) that was developed specifically for this purpose. The spreadsheet calculates the amount of energy harnessed by comparing the specified inlet fluid temperature to the temperature in the pavement at a depth for that hour. The total energy harnessed is the sum of the energy harnessed for every hour of the year. Time intervals, where the temperature of the pavement at a depth is below that of the specified inlet water temperature, are ignored. In this situation, the system would presumably not be running, as it would result in a loss of energy during this time. The total energy harnessed is converted into an equivalent yearly saving via the cost of electricity. Next, the payback period is calculated for an installation at a specific location.

Three major factors are considered:

- initial capital cost,
- yearly costs and
- yearly savings.

The capital costs consist of the fixed initial costs such as a monitoring system, pipe supports and pump, as well as the costs that vary with the size of the network like the piping. Similarly, the yearly costs and yearly savings vary with the size of the network as well as the selected flow rate for the system. The resulting payback period is calculated by taking the initial capital cost and dividing it by the difference

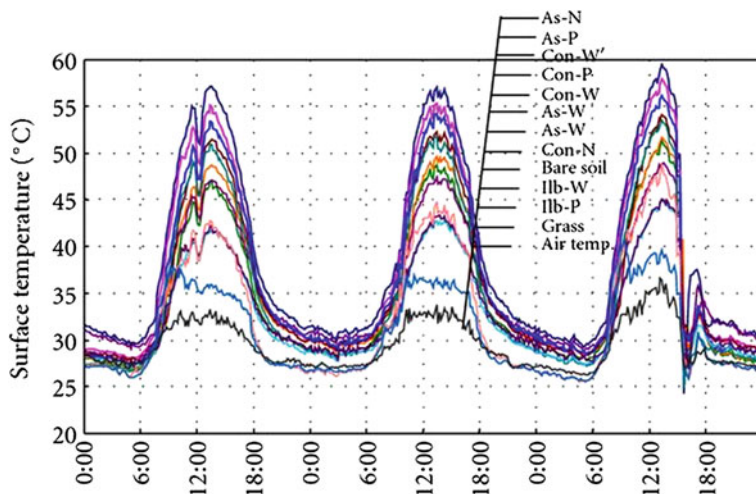

**Fig. 18.20** Temperature in various experimental pavements (Takebayashi and Moriyama 2012). See Fig. 18.19 for explanation of codes

of the yearly savings and yearly cost. Mallick et al. (2011) had presented the economic feasibility of this concept for five cities, Boston, Phoenix, Miami and Houston, USA, Singapore, and Chennai, India, and showed that the payback period (time to reach positive cash flow) is directly related to the amount of heat energy that is extractable (or available), which varies with a change in the latitude of the location—higher the latitude, the longer is the payback period. For the conditions used in the analyses, the payback periods were calculated as Boston (30 years), Phoenix (5), Miami (5) and Houston (5) in USA, Singapore (2), and Chennai, India (4 years).

The benefits of extraction of heat energy from pavements are more than just those that are related to the direct use of the energy—there are side benefits as well. For example, an extraction of heat leads to a lowering of surface temperature of the pavements. The effect of evaporation at reducing heat is shown in Fig. 18.20 where it can be seen that a reduction of as much as much as 15 °C is achievable. Heat abstraction for beneficial reuse can probably not achieve such a great reduction, but a reduction of more than 10 °C may be achievable, depending on the specific factors of climate, materials, installation, use, etc.

A reduction in temperature of 5 °C will reduce the amount of rutting experienced and longitudinal cracking that can be expected over a particular timescale. Thus, if these deterioration modes are critical, temperature reduction will certainly extend a pavement’s life by a measurable amount—perhaps by several years.

This lowering of pavement surface temperature leads to a lowering of the thermal long wave radiation from the pavement to the near surface air, and thus decreases the potential of urban heat island effect (UHI). This has a number of important consequences (Akbari 1995). Researchers have conclusively proven the

detrimental effect of UHI, and hence a lowering of its intensity will translate to many benefits (Rosenfeld et al. 1996) such as, improvement of air quality, reduction of adjacent building temperature, a decrease in the use of cooling/air conditioning activities in the buildings, and a consequent decrease in the use of electricity and emissions from such use, as well as the many consequential health benefits. It has been shown that cooling cities by 3 °C can cut smog by 12 % as well as saving enormous sums of money in reduced energy demands for air conditioning.

Therefore, the benefits need to be assessed in terms of impacts on use of energy, use of natural resources as well as environmental quality. Such analysis will require the consideration of meteorology and also heat exchanges in the local environment.

## 18.10 Conclusion

This chapter has sought to indicate the very high potential for pavement-based energy harvesting starting with the observation that an enormous amount of solar-derived energy is available in pavements. Furthermore the costs for collecting that energy ought to be relatively low (compared with other means) as the basic infrastructure is already paid for from the transportation budget. Nevertheless, there are many hurdles to be overcome before successful, widespread, harvesting of that energy can be achieved. These include:

- Economy of plant—inefficient cheap harvesting over a wide area of pavement might be better than a highly efficient harvesting technique that can only be afforded at a few discrete locations.
- Retrofitting—many pavements are already constructed and simple and reliable techniques are required to install harvesting arrangements into existing infrastructure.
- Durability and maintainability—this applies to both the harvesting arrangements and to their host pavements. The long-term response of each when acting together isn't well known and the implications are not well-understood.
- Preferred technology—there are many technologies being developed but the relative benefits and drawbacks associated with each are not, in general known. The ideas and implementations are all rather young and, hence, future outcomes are uncertain.

The needs now are to start deploying systems in order to build on existing knowledge and develop experience. Just as many countries have provided tax, grant, regulatory or other incentives to encourage building owners to install PVs on roofs, there is a need for authorities to adopt pump-priming strategies for pavement-based energy harvesting. In this way a more mature industry can be developed in terms of plant, design and evaluation where hype gives way to rational decision-making. Both solution providers and potential owners need greater awareness of the

potential benefits and the difficulties and limitations so that pavement-based energy harvesting systems become deployed in as many as possible of the locales in which it is sensible to deploy them.

## References

- Akbari, H. (1995). *Cooling our communities: An overview of heat island project activities*. Annual report. Berkeley: Heat Island Group, Lawrence Berkeley National Laboratory.
- Akbari, H. (2005). *Energy saving potentials and air quality benefits of urban heat Island mitigation*. Report LBNL-58285. Lawrence Berkeley National Laboratory.
- Armstrong, F., & Blundell, K. (2007). *Energy...beyond oil*. Oxford: Oxford University Press.
- Athienitis, A. K., Liu, C., Hawes, D., Banu, D., & Feldman, D. (1997). Investigation of the thermal performance of a passive solar test-room with wall latent heat storage. *Building and Environment*, 32(5), 405–410.
- Banks, D. (2008). *An introduction to thermogeology: Ground source heating and cooling*. Oxford: Blackwell Publishing Ltd.
- Bentz, D. P., & Turpin, R. (2007). Potential applications of phase change materials in concrete technology. *Cement and Concrete Composites*, 29(7), 527–532.
- Bo, G., Biao, M., & Fang, Q. (2011). Application of asphalt pavement with phase change materials to mitigate urban heat Island effect. In *Proceedings of International Symposium on Water Resource and Environmental Protection (ISWREP)*, May, Xian, Shaanxi, China.
- Botts, M., & Mouw, I. (2013). *Here comes the sun* (pp. 19–21). Fredericksburg: International Parking Institute.
- Busby, J., Lewis, M., Reeves, H., & Lawley, R. (2009). Initial geological consideration before installing ground source heat pump systems. *Journal of Engineering Geology and Hydrogeology*, 42, 295–306.
- Cambridge Systematics. (2005). *Cool pavement report, EPA cool pavements study—task 5*. [http://www.epa.gov/heatisland/resources/pdf/CoolPavementReport\\_Former%20Guide\\_complete.pdf](http://www.epa.gov/heatisland/resources/pdf/CoolPavementReport_Former%20Guide_complete.pdf).
- Carder, D. R., Barker K. J., Hewitt, M. G., Ritter, D., & Kiff, A. (2007). *Performance of an interseasonal heat transfer facility for collection, storage, and re-use of solar heat from the road surface*. Crowthorne: Transport Research Laboratory, Published Project Report PPR 302.
- Côté, J., & Konrad, J. M. (2005). Thermal conductivity of base-course materials. *Canadian Geotechnical Journal*, 42(1), 61–78.
- Dawson, A. R., Keikhaei Dehdezi, P., Hall, M. R., Wang, J., & Isola, R. (2012). Enhancing thermal properties of asphalt materials for heat storage and transfer applications. *Road Materials and Pavement Design*, 13(4), 784–803.
- de Bondt, A. (2003). Generation of Energy via Asphalt Pavement Surfaces. *Asphaltica Padova 2003*.
- de Wild-Scholten, M. J. (2013). Energy payback time and carbon footprint of commercial photovoltaic systems. *Solar Energy Materials and Solar Cells*, 119, 296–305.
- Duarte, F., Casimiro, F., Correia, D., Mendes, R., & Ferreira, A. (2013). Waynergy people: A new pavement energy harvest system. *Municipal Engineer, Institute of Civil Engineers*, 166(4), 250–256.
- Entrop, A. G., Brouwers, H. J. H., & Reinders, A. H. M. E. (2011). Experimental research on the use of micro-encapsulated phase change materials to store solar energy in concrete floors and to save energy in Dutch houses. *Solar Energy*, 85(5), 1007–1020.
- Ewing, R. P., & Horton, R. (2007). Thermal conductivity of a cubic lattice of spheres with capillary bridges. *Journal of Physics D: Applied Physics*, 40(16), 4959–4965.
- Garcia, A., & Partl, M. N. (2014) How to transform an asphalt concrete pavement into a solar turbine. *Applied Energy*, 119(C), 431–437.



- Hall, M. R., Keikhaei Dehdezi, P., Dawson, A. R., Grenfell, J., & Isola, R. (2012). Influence of the thermo-physical properties of pavement materials on the evolution of temperature depth profiles in different climatic regions. *Journal of Materials in Civil Engineering*, 24(1), 32–47.
- Hasebe, M., Kamikawa, Y., & Meiarashi, S. (2006). Thermoelectric generators using solar thermal energy in heated road pavement. In *25th International Conference on Thermoelectrics*.
- Hunger, M., Entrop, A. G., Mandilaras, I., Brouwers, H. J. H., & Founti, M. (2009). The behavior of self-compacting concrete containing micro-encapsulated phase change materials. *Cement and Concrete Composites*, 31(10), 731–743.
- Inhabit. (2013). <http://inhabitat.com/students-install-the-worlds-first-solar-pavement-panels-in-virginia/solar-walk-up-jmc-2013-9954-460x260/>.
- James, W. (2002). Green roads: research into permeable pavers. *Stormwater*, 3(2), 40–48.
- Keikhaei Dehdezi, P., Hall, M. R., & Dawson, A. R. (2011). Thermo-physical optimisation of specialised concrete pavement materials for surface heat energy collection and shallow heat storage applications. *Transportation Research Record (Journal of the Transportation Research Board)*, 2240, 96–106.
- Keikhaei Dehdezi, P. (2012). Enhancing pavements for thermal applications. PhD thesis, Department of Civil Engineering, University of Nottingham, p. 225.
- Keikhaei Dehdezi, P., Dawson, A. R., Hall, M. R., & Casey, S. (2012a). Investigate the feasibility of using asphalt pavements as a source of heating. *2nd International Symposium on Asphalt Pavements & Environment*, 1st–3rd October, Fortaleza, Brazil.
- Keikhaei Dehdezi, P., Hall, M. R., & Dawson, A. R. (2012b). Enhancement of soil thermo-physical properties using microencapsulated phase change materials for ground source heat pump applications. *Applied Mechanics and Materials*, 110–116, 1191–1198.
- Keikhaei Dehdezi, P., Hall, M. R., Dawson, A. R., & Casey, S. (2012c). Thermal, mechanical, and microstructural analysis of concrete containing microencapsulated phase change materials. *International Journal of Pavement Engineering*, 14(5), 1–14.
- Leong, W. H., Tarnawski, V. R., & Aittomäki, A. (1998). Effect of soil type and moisture content on ground heat pump performance: Effet du type et de l'humidité du sol sur la performance des pompes à chaleur à capteurs enterrés. *International Journal of Refrigeration*, 21(8), 595–606.
- Lopes-Ferreira, A. J. (2012). Recent developments in pavement energy harvest systems. *Municipal Engineer, Institution of Civil Engineers*, 165(4), 189–192.
- Lund, J. (2002). Pavement Snow Melting. Geo-Heat Center, Oregon Institute of Technology, Klamath Falls. <http://geoheat.oit.edu/bulletin/bull21-2/art4.pdf>.
- Ma, B., Wang, S., & Li, J. (2010). Study on application of PCM in Asphalt mixture. *Journal of Advanced Materials Research*, 168–170, 2625–2630.
- Mallick, R. B., Chen, B.-L., & Bhowmick, S. (2009). Harvesting energy from asphalt pavements and reducing the heat island effect. *International Journal of Sustainable Engineering*, 2(3), 214–228.
- Mallick, R., Carelli, J., Albano, L., Bhowmick, S., & Veeraragavan, A. (2011). Evaluation of the potential of harvesting heat energy from asphalt pavements. *International Journal of Sustainable Engineering*, 4(02), 164–171.
- Mallick, R., & Bhowmick, S. (2013). Rise in pavement temperature—Making buildings part of the road infrastructure, capturing energy—Solutions, possibilities and challenges. *Sustain*, 29, 36–46.
- McGlen, R., Kew, P., & Rea, D. (2006). *Heat pipes: Theory, design and applications* (p. 384). Oxford: Butterworth-Heinemann.
- Mehling, H., & Cabeza, L. F. (2008). *Heat and cold storage with PCM*. Berlin: Springer.
- NASA. (2014). <http://science.larc.nasa.gov/erbe>.
- OKState. (2002). Geothermal Smart Bridge, What's New. <http://www.smartbridge.okstate.edu/whatsnew.html>.
- Park, D.-W., Dessouky, S., & Hwang, S.-D. (2014). Thermophysical properties of graphite-modified asphalt mixture and numerical analyses for snow melting pavement. In M. Losa & T. Papagiannakis (eds.) Chapter 10, *Sustainability, eco-efficiency, and conservation in transportation infrastructure asset management* (pp. 87–94). Boca Raton: CRC Press.



- Pavegen. (2012). Generating Energy from Footsteps. Pavegen Systems Ltd, UK. <http://www.pavegen.com>.
- Read, J., & Whiteoak, D. (2003). *The shell bitumen handbook*. London: Thomas Telford Publishing.
- Rosenfeld, A. H., Romm, J. J., Akbari, H., Pomerantz, M., Taha, H. (1996). Policies to reduce heat islands: magnitudes of benefits and incentives to achieve them. *Proceedings of 1996 LBL-38679, ACEEE summer study on energy efficiency in buildings* (Vol. 9, pp. 177–186).
- Russell, R. (2007). Solar Energy in Earth's Atmosphere. [http://www.windows2universe.org/earth/Atmosphere/earth\\_atmosph\\_radiation\\_budget.html](http://www.windows2universe.org/earth/Atmosphere/earth_atmosph_radiation_budget.html).
- Sundberg, J. (1988). *Thermal properties of soil and rocks*. Linköping: Swedish Geotechnical Institute.
- Tarnawski, R., Momose, T., & Leong, W. H. (2009). Assessing the impact of quartz content on the prediction of soil thermal conductivity. *Geotechnique*, 59(4), 331–338.
- Sánchez, P., Sánchez-Fernandez, M. V., Romero, A., Rodríguez, J. F., & Sánchez-Silva, L. (2010). Development of thermo-regulating textiles using paraffin wax microcapsules. *Thermochimica Acta*, 498(1–2), 16–21.
- Sedgwick, R. H. D., & Patrick, M. A. (1981). The use of a ground solar collector for swimming pool heating. Paper to 1st Solar World Forum, Brighton, England. *Proceedings of International Solar Energy Society*, 1, 632–636.
- Sullivan, C., de Bondt, A. H., Jansen, R., & Verweijmeren, H. (2007). Innovation in the production and commercial use of energy extracted from asphalt pavements. 6th Annual International Conference on Sustainable Aggregates, *International Journal of Pavement Engineering and Asphalt Technology*, 8(2). Liverpool.
- Takebayashi, H., & Moriyama, M. (2012). Study on surface heat budget of various pavements for urban heat island mitigation. *Advances in Materials Science and Engineering*, 2012 (523051), 11.
- Waydip. (2012). Waynergy. Waydip—Energia e Ambiente, Lda, Portugal. <http://www.waydip.com>.
- Wong, N. H., & Chen, Y. (2009). *Tropical Urban Heat Islands*. Abingdon: Taylor & Francis.
- Wu, S., Chen, M., & Zhang, J. (2011). Laboratory investigation into thermal response of asphalt pavements as solar collector by application of small-scale slabs. *Applied Thermal Engineering*, 31(10), 1582–1587.