

Shengzhao Long  
Balbir S. Dhillon  
*Editors*

# Proceedings of the 14th International Conference on Man– Machine–Environment System Engineering



# Lecture Notes in Electrical Engineering

Volume 318

## Board of Series editors

Leopoldo Angrisani, Napoli, Italy  
Marco Arteaga, Coyoacán, México  
Samarjit Chakraborty, München, Germany  
Jiming Chen, Hangzhou, P.R. China  
Tan Kay Chen, Singapore, Singapore  
Rüdiger Dillmann, Karlsruhe, Germany  
Gianluigi Ferrari, Parma, Italy  
Manuel Ferre, Madrid, Spain  
Sandra Hirche, München, Germany  
Faryar Jabbari, Irvine, USA  
Janusz Kacprzyk, Warsaw, Poland  
Alaa Khamis, New Cairo City, Egypt  
Torsten Kroeger, Stanford, USA  
Tan Cher Ming, Singapore, Singapore  
Wolfgang Minker, Ulm, Germany  
Pradeep Misra, Dayton, USA  
Sebastian Möller, Berlin, Germany  
Subhas Mukhopadhyay, Palmerston, New Zealand  
Cun-Zheng Ning, Tempe, USA  
Toyoaki Nishida, Sakyo-ku, Japan  
Federica Pascucci, Roma, Italy  
Tariq Samad, Minneapolis, USA  
Gan Woon Seng, Nanyang Avenue, Singapore  
Germano Veiga, Porto, Portugal  
Haitao Wu, Beijing, China  
Junjie James Zhang, Charlotte, USA

### *About this Series*

“Lecture Notes in Electrical Engineering (LNEE)” is a book series which reports the latest research and developments in Electrical Engineering, namely:

- Communication, Networks, and Information Theory
- Computer Engineering
- Signal, Image, Speech and Information Processing
- Circuits and Systems
- Bioengineering

LNEE publishes authored monographs and contributed volumes which present cutting edge research information as well as new perspectives on classical fields, while maintaining Springer’s high standards of academic excellence. Also considered for publication are lecture materials, proceedings, and other related materials of exceptionally high quality and interest. The subject matter should be original and timely, reporting the latest research and developments in all areas of electrical engineering.

The audience for the books in LNEE consists of advanced level students, researchers, and industry professionals working at the forefront of their fields. Much like Springer’s other Lecture Notes series, LNEE will be distributed through Springer’s print and electronic publishing channels.

More information about this series at <http://www.springer.com/series/7818>

Shengzhao Long · Balbir S. Dhillon  
Editors

# Proceedings of the 14th International Conference on Man–Machine–Environment System Engineering



 Springer

*Editors*

Shengzhao Long  
Astronaut Research and Training  
Center of China  
Beijing  
China

Balbir S. Dhillon  
University of Ottawa  
Ottawa, ON  
Canada

ISSN 1876-1100

ISBN 978-3-662-44066-7

DOI 10.1007/978-3-662-44067-4

ISSN 1876-1119 (electronic)

ISBN 978-3-662-44067-4 (eBook)

Library of Congress Control Number: 2014944335

Springer Heidelberg New York Dordrecht London

© Springer-Verlag Berlin Heidelberg 2015

This work is subject to copyright. All rights are reserved by the Publisher, whether the whole or part of the material is concerned, specifically the rights of translation, reprinting, reuse of illustrations, recitation, broadcasting, reproduction on microfilms or in any other physical way, and transmission or information storage and retrieval, electronic adaptation, computer software, or by similar or dissimilar methodology now known or hereafter developed. Exempted from this legal reservation are brief excerpts in connection with reviews or scholarly analysis or material supplied specifically for the purpose of being entered and executed on a computer system, for exclusive use by the purchaser of the work. Duplication of this publication or parts thereof is permitted only under the provisions of the Copyright Law of the Publisher's location, in its current version, and permission for use must always be obtained from Springer. Permissions for use may be obtained through RightsLink at the Copyright Clearance Center. Violations are liable to prosecution under the respective Copyright Law. The use of general descriptive names, registered names, trademarks, service marks, etc. in this publication does not imply, even in the absence of a specific statement, that such names are exempt from the relevant protective laws and regulations and therefore free for general use.

While the advice and information in this book are believed to be true and accurate at the date of publication, neither the authors nor the editors nor the publisher can accept any legal responsibility for any errors or omissions that may be made. The publisher makes no warranty, express or implied, with respect to the material contained herein.

Printed on acid-free paper

Springer is part of Springer Science+Business Media ([www.springer.com](http://www.springer.com))

# Xuesen Qian' Estimation



Grandness Scientist Xuesen Qian' Sky-high Estimation for the Man-Machine-Environment System Engineering

龙升照同志:

我收到您主编的《人机环境系统工程研究进展(第一卷)》, 翻阅了之后, 感到非常高兴, 1985年秋提出的一个想法, 现在8年之后已赫然成书, 500多页的巨卷! 而且研究范围已大大超出原来航天, 内容涉及航空、航天、航海、兵器、电子、能源、交通、电力、煤炭、冶金、体育、康复、管理……等领域! 你们是在社会主义中国开创了这门重要现代科学技术!

此致

敬礼!

钱学森

1993-10-22

# Xuesen Qian' Letter



Grandness Scientist Xuesen Qian' Congratulatory Letter to the 20th Anniversary Commemorative Conference of Man–Machine–Environment System Engineering Foundation



龙升照同志：

你的来信已收到。欣悉人-机-环境系统工程创立 20 周年纪念大会暨第五届全国人-机-环境系统工程学术会议即将召开，我向你们表示最热烈的祝贺！

20 年来，你们在人-机-环境系统工程这一新兴科学领域进行了积极的开拓和探索，并取得了非常可喜的成绩，我感到由衷的高兴。

希望你们今后再接再厉，大力推动人-机-环境系统工程理论及应用的蓬勃发展，为中国乃至世界科学技术的进步作出积极贡献！

祝

工作顺利！

钱学森  
2001年6月26日

# Preface

In 1981, under the directing of the great scientist Xuesen Qian, an integrated frontier science—Man–Machine–Environment System Engineering (MMESE)—came into being in China. Xuesen Qian gave high praise to this emerging science. In the letter to Shengzhao Long, he pointed out, **“You are creating this very important modern science and technology in China!”** in October 22, 1993.

In the congratulation letter to the commemoration meeting of 20th anniversary of establishing the MMESE, the great scientist Xuesen Qian stated, “You have made active development and exploration in this new emerging science of MMESE, and obtained encouraging achievements. I am sincerely pleased and hope you can do even more to make prosper development in the theory and application of MMESE, and **make positive contribution to the progress of science and technology in China, and even in the whole world**” in June 26, 2001.

October 22nd, which is the day that the great scientist Xuesen Qian gave high praise to MMESE, was determined to be Foundation Commemoration Day of MMESE by the second conference of the fifth MMESE Committee on October 22, 2010. On this very special day, the great scientists Xuesen Qian pointed out in the letter to Shengzhao Long, **“You are creating this very important modern science and technology in China!”** And the conference also determined that the annual Conference on MMESE would be held from October 21st to 24th to cherish the memory of the great contributions that the great scientist Xuesen Qian had made to the MMESE!

The 14th International Conference on MMESE will be held in Guilin, China on October 21st–24th of this year; hence, we will dedicate *Proceedings of the 14th International Conference on Man–Machine–Environment System Engineering* to our readers.

*Proceedings of the 14th International Conference on Man–Machine–Environment System Engineering* is the academic showcases of the 14th International Conference on MMESE joint held by MMESE Committee of China and Beijing KeCui Academe of MMESE in Guilin, China. The conference proceedings is

consisted of 52 more excellent papers selected from more than 400 papers. Due to limitations on space, some excellent papers have been left out, we feel deeply sorry for that. Crudeness in contents and possible incorrectness are inevitable due to the somewhat pressing editing time and we hope you kindly point them out promptly, and your valuable comments and suggestions are also welcomed.

*Proceedings of the 14th International Conference on Man–Machine–Environment System Engineering* will be published by Springer-Verlag, German. Springer-Verlag is also responsible for the related matters on index of Index to EI and CPCI-S (ISTP), so that the world can know the research quality and development trend of MMESE theory and application. Therefore, the publication of *Proceedings of the 14th International Conference on Man–Machine–Environment System Engineering* will greatly promote the vigorous development of MMESE in the world, and realize the grand object of **making positive contribution to the progress of science and technology in China, and even in the whole world** proposed by Xuesen Qian.

We would like to express our sincere thanks to Springer-Verlag, German for their full support and help of during the publishing process.

Beijing, July 2014

Shengzhao Long

# **Program and Technical Committee Information**

## **General Chairman**

Professor Shengzhao Long, Astronaut Research and Training Center of China

## **Program Committee Chairman**

Professor Balbir S. Dhillon, University of Ottawa, Canada

## **Technical Committee Chairman**

Professor Enrong Mao, College of Engineering, China Agricultural University, China

## **Program and Technical Committee Members**

Professor J.G. Kreifeldt, Tufts University, USA

Professor Yanping Chen, University of Management and Technology, USA

Professor Hongfeng Gao, University of California, USA

Professor Xiangshi Ren, Kochi University of Technology, Japan

Professor Kinhuat Low, Nanyang Technological University, Singapore

Senior Engineer Baoguo Luan, CH-AUTO Technology Co. Ltd, China

Professor Baoqing Xia, Weapon Industrial Hygiene Research Institute, China

Professor Chunhui Wang, Astronaut Research and Training Center of China, China

Professor Fang Jie, China North Vehicle Research Institute, China  
Senior Engineer Fong Zhou, AVIC Aerospace Life-support Industries Ltd, China  
Professor Guangtao Ma, Shenyang Jianzhu University, China  
Professor Guansheng Huang, Beijing Special Vehicle Institute, China  
Professor Guohua Jiang, Astronaut Research and Training Center of China  
Professor Guohua Shi, Engineering Academy of the Second Artillery, China  
Professor Haiming Wu, Weapon Industrial Hygiene Research Institute, China  
Professor Hao Li, Astronaut Research and Training Center of China, China  
Professor Hongjun Xue, Northwestern Polytechnical University, China  
Professor Honglei Zhang, Air Defense Forces Academy, China  
Senior Engineer Jiajun Sun, Petrochina Changqing Oilfield Company, China  
Professor Junfeng Liu, Educational Technology Center of Dalian, China  
Professor Lijing Wang, Beijing University of Aeronautics and Astronautics, China  
Professor Long Ye, Beijing Jiaotong University, China  
Professor Xiaochao Guo, Institute of Aviation Medicine, Air Force, China  
Professor Xingwei Wang, Institute of Aviation Medicine, Air Force, China  
Professor Ying Jin, Astronaut Research and Training Center of China, China  
Professor Yonghua Tao, Naval Medical Research Institute, China  
Professor Yongqing Hou, China Academy of Space Technology, China  
Professor Yuhong Shen, Quartermaster Research Institute of the General Logistics  
Department of CPLA, China  
Professor Zhibing Pang, Air Defense Forces Academy, China

# Contents

## Part I Research on the Man Character

<b>1</b>	<b>Performance of Ergonomics from 2001 to 2012</b> . . . . .	<b>3</b>
	Jie Li, Menglu Li, Xiaohong Guo and Aleksandar Jovanovic	
<b>2</b>	<b>Perceived Fatigue Evaluating Model in Health Men Performing Backpack Load-Carriage Exercises</b> . . . . .	<b>13</b>
	Yuhong Shen, Jiewen Zheng, Chenming Li, Yafei Guo and Pengfei Ren	
<b>3</b>	<b>The Changes of Physiological and Biomechanical Indices and Their Relations to Fatigue During Treadmill Walking with Different Loads</b> . . . . .	<b>23</b>
	Jiewen Zheng, Yuhong Shen, Chenming Li, Pengfei Ren and Yafei Guo	
<b>4</b>	<b>Marine Nuclear Power Plant Human Error Analysis and Protective Measures</b> . . . . .	<b>33</b>
	Chuan Wang, Jianguo Zhang, Hao Yu and Shenglong Dai	
<b>5</b>	<b>The Development of Professional Morality Questionnaire for Civil Pilots</b> . . . . .	<b>43</b>
	Yuchuan Luo, Xiaoli Luo, Quanchuan Wang and Xianlin Zeng	
<b>6</b>	<b>Study on Function of Neurotransmitters and Brain of Chronic Brain fog Sufferers</b> . . . . .	<b>51</b>
	Yaofeng He, Guansheng Huang, Haiyan Niu, Yuping Luo, Yajuan Bai and Jianlan Xu	
<b>7</b>	<b>A Study on Analysis of Learners in Instructional Design</b> . . . . .	<b>59</b>
	Yanyan Chen, Genhua Qi and Hong He	

**8 On How to Foster the Officer Cadets’ Psychological Quality of Operational Command . . . . . 67**  
Rongzhi Yang, Hai Chang, Danfeng Liu,  
Zengjun Ji and Shujie Zhang

**9 Eye-Tracking Analysis for the Disabled in the Spatial Environment . . . . . 75**  
Yuanzhe Fan, Weimin Wang, Yuhui Xin, Meiyu Lv and Lan Wang

**10 A Research of NATO Forces Fitness on Man–Machine Operation and Its Enlightenment . . . . . 83**  
Weizhong Liu

**11 Analysis of the Psychological Connotations of the Military College Course Designer . . . . . 91**  
Hua Li, Huifang Wang, Jianhe Wang, Guoxiang Tian,  
Jie Xing and Weixin Liu

**12 Study on Comprehensive Quality Evaluation of Military Science Postgraduate . . . . . 97**  
Shenhua Huang, Hongyan Ou, Lin Chen, Chenhui Li,  
Guoan Shi and Huiyong Wang

**13 Analysis and Study About Military Large Special Vehicle Driver’s Attention Characters . . . . . 105**  
Xiang Gao, Jianjun Li, Shuai Mu, Haiwen Zheng,  
Min Chen and Ming Kong

**14 Experimental Study on 5-km Armed Cross-Country Based on Heart Rate Data Analysis . . . . . 113**  
Honglei Li, Zhibing Pang, Meng Kang, Xiaogao Wang,  
Shuai Mu, Miaofei Chen, Haitao Zhao, Hongyan Ou,  
Ming Kong and Min Chen

**15 Exploring the Psychophysical Relationship Between Basic Fabric Construction Parameters and Typical Tactile Sensations . . . . . 121**  
Ruitao Jiang, Jiyong Hu, Yuan Zhang and Xin Ding

**16 The Body Mass Index of Taikonaut Candidates . . . . . 129**  
Xiaochao Guo, Duanqin Xiong, Yanyan Wang, Chunmei Gui,  
Guowei Shi, Jian Du and Yu Bai

**17 Human Dimensions of Chinese Male Pilots in Sitting Posture and Some Changes . . . . . 135**  
 Xiaochao Guo, Duanqin Xiong, Yanyan Wang, Guowei Shi, Chunmei Gui, Wei Zheng and Qingfeng Liu

**Part II Research on the Machine Character**

**18 Research on the Design of the Ecological Atrium in the Architecture . . . . . 143**  
 Zhen Li

**19 On-Orbit Mission Assisting and Supporting System Based on AR . . . . . 151**  
 Xiuqing Zhu, Yuqing Liu and Bohe Zhou

**20 Manufacture Process Evaluation of IFOG Using Multiple-Test Data Analysis . . . . . 159**  
 Lianjie Shan, Yingchun Liang and Haoting Liu

**21 Design of a New Electrohydraulic Control System for Segment Rotational Motion . . . . . 167**  
 Xu Yang, Guofang Gong, Weiqiang Wu and Yunyi Rao

**22 Ergonomics Research of EVA Handhold Cross-Sectional Dimensions. . . . . 175**  
 Yulin Xu, Changhua Jiang, Zheng Wang, Li Wang, Suying Yao and Chunhui Wang

**Part III Research on the Environment Character**

**23 Analysis on the Oxygen Flow Index of Special Vehicle Oxygen Generator . . . . . 185**  
 Yuping Luo, Yaofeng He, Guansheng Huang and Yajuan Bai

**24 Technology of Waste Disposal in Long-Term Manned Spacecraft. . . . . 191**  
 Lantao Zhang, Chuanfeng Wei, Wencheng Luo and Fanlu Bai

**25 Analysis of the Mold Resistance of the Non-metal Materials on Space Station and Suggestions of Improvement Measures . . . . 197**  
 Fanlu Bai, Chuanfeng Wei and Lantao Zhang



**26 A Model Construction Based on Research Capability of Laboratory Environmental Worthiness . . . . . 203**  
 Zhibing Pang, Hualiang Xu, Zaochen Liu, Hongyan Ou, Chenhui Li and Cheng Jin

**Part IV Research on the Man–Machine Relationship**

**27 Study on Impact Analysis of Eye Movement Data to the Bottom-Up Significant Area Calculation Model . . . . . 213**  
 Yajuan Bai, Meng Yang, Yaofeng He, Yuping Luo and Guansheng Huang

**28 Integrated Evaluation of Pilot Situational Awareness in Man–Machine Interaction. . . . . 221**  
 Binchun Liu and Wanqing Li

**29 On the Eye Movement Technique-Based HMI Work Efficiency Evaluation System. . . . . 231**  
 Chenhui Li, Zhibing Pang, Zengjun Ji, Honglei Li, Haitao Zhao and He Wei

**30 Ergonomic Evaluation Methods of Cockpit Lighting in Aircrafts . . . . . 241**  
 Duanqin Xiong, Xiaochao Guo, Wang Hong, Chunmei Gui, Guowei Shi, Bai Yu and Du Jian

**Part V Research on the Man–Environment Relationship**

**31 The Analysis and Research on the Design Concept of the Agile Pilot Clothing System. . . . . 249**  
 Guangjun Feng, Feng Qiu, Yubin Zhu and Haibo Zhang

**32 Effects of Color Rendering Index of Light Source on Color Task of Comparison and Fast Identification . . . . . 259**  
 Jie Li, Weihao Yang and Sugang Wang

**33 Research on the Influence of Traffic Conditions on the Psychology of Indirect Vision Drivers Based on EEG Analysis . . . . . 267**  
 Zhiying Qiu, Zhicheng Wu, Jingjie Wu, Jie Bao and Jia Zhou

**34 Contrast Research on Ergonomics of Vehicle Drivers in Indirect and Direct Vision Environment . . . . . 277**  
 Jia Zhou, Zhicheng Wu, Jingjie Wu, Zhiying Qiu and Jie Bao

**35 Research on Environmental Suitability of Operation Staffs at Frigid Plateau Region. . . . . 285**  
 He Wei, Honglei Li, Zhibing Pang, Cheng Jin, Yuankang Sun and Xingbin Zhu

**36 Features of Selection Indicators for Alpine Plateau Operator. . . . . 293**  
 Cheng Jin, Zhibing Pang, Honglei Li, Jiang Wu, Hua Li and Quanliang Yin

**37 Research on the Correlation Between University Students’ Assessment of Sports Environment and Their Physical Exercises Behavior . . . . . 301**  
 Min Chen, Jing Sun, Jianjun Li, Shuai Mu, Xiang Gao, Yang Yang, Tian Yang, Ming Kong and Miaofei Chen

**38 Friction Behaviour of Medical Compression Stockings Against Various Skin Models . . . . . 311**  
 Wei Ke, Jiyong Hu and Xin Ding

**39 Study on Aircrew Survival Experiment on Plateau . . . . . 319**  
 Xingwei Wang, Lue Deng, Hailiang Zhou, Qin Yao, Changlin Yang, Lixiong Chen, Heqing Liu, Hong Xie and Yongchang Luo

**40 The Influence of Transcranial Micro-electric Current Physiological Training on Cerebral Function Under Altitude Hypoxia . . . . . 329**  
 Yongsheng Chen and Yongchang Luo

**Part VI Research on the Machine–Environment Relationship**

**41 Simulation of Flight Dynamics for Helicopter Icing . . . . . 341**  
 Ruimin Zhang, Junbo Zhao and Jingang Dong

**42 The Ergonomics Application Research on Differences Between Adaptive Cruise Control System and Drivers. . . . . 349**  
 Yuru Gao, Yang Cao and Sen Zhao

**43 Plateau Alpine Environment Impact Study of a Certain Type of Air Defense Missile . . . . . 357**  
 Zhibing Pang, Honglei Li, Qiang Gao, Cheng Jin,  
 Xingbin Zhu and Yuankang Sun

**Part VII Research on the Overall Performance of Man–Machine–Environment System**

**44 Core Sector Risk Assessment Model Based on AHP of Confidentiality . . . . . 367**  
 Baohang Shao and Wei Liu

**45 The Study on Increasing Vehicle Passing Rate at Intersection Based on Ergonomics . . . . . 375**  
 Jianwei Wang and Beihai Wang

**46 A Research on BDS-Based Air Observation and Surveillance System . . . . . 381**  
 Zhibing Pang, Haitao Zhao, Hong He, Chenhui Li,  
 Jiang Wu and Hongyan Ou

**47 Design on Mobile Interactive Control for a Space Flight Training Simulator . . . . . 389**  
 Shang Huan, Baozhi Wang and Wanhong Lin

**48 Modeling and Simulation in Rendezvous and Docking Spaceflight Training . . . . . 399**  
 Baozhi Wang

**49 The Research of Vehicle Dynamics Modeling and Real-Time Simulation Technique Based on Vortex . . . . . 409**  
 Fang Xie, Zhong Zheng, Sijuan Zheng,  
 Zhongliang Wei and Qun Wang

**Part VIII Theory and Application Research**

**50 Evidence-Based Ergonomics and Application in Manned Space Flight . . . . . 419**  
 Hong Liang, Zhijun Xiao, Jianhui Li, Guohua Jiang,  
 Hong Qi, Yongjie Ma, Ping Liao and Yumei Zhang

**51 The Improvement on Space Human Factor Engineering of NASA . . . . . 427**  
Jing Qiang and Yuanyuan Zhang

**52 Man–Machine–Environment Systems Engineering Research Based Mental Workload Measurement Model of Using Software . . . . . 437**  
Baiqiao Huang and Yuanhui Qin

# Biography of Editor in Chief

**Prof. Shengzhao Long** He is the founder of the Man–Machine–Environment System Engineering (MMESE), the Chairman of the MMESE Committee of China, the Chairman of the Beijing KeCui Academy of MMESE and the Former Director of Ergonomics Lab of Astronaut Research and Training Center of China. In October 1992, he is honored by the National Government Specific Allowance.

Graduated from the Shanghai Science and Technology University in 1965, China. In 1981, directing under famous Scientist Xuesen Qian, founded MMESE theory. In 1982, proposed and developed Human Fuzzy Control Model using fuzzy mathematics. From August of 1986 to August of 1987, conducted research in Man–Machine System as a visiting scholar at Tufts University, Massachusetts, U.S.A. In 1993, organized MMESE Committee of China. Published “Foundation of Theory and Application of Man–Machine–Environment System Engineering”(2004) and “Man–Machine–Environment System Engineering”(1987). Edited “Proceedings of the 1st–13th Conference on Man–Machine–Environment System Engineering”(1993–2013). e-mail: shzhlong@sina.com

**Dr. Balbir S. Dhillon** He is a professor of Engineering Management in the Department of Mechanical Engineering at the University of Ottawa, Canada. He has served as a Chairman/Director of Mechanical Engineering Department/Engineering Management Program for over 10 years at the same institution. He has published over 345 (i.e., 201 journal + 144 conference proceedings) articles on reliability, safety, engineering management, etc. He is or has been on the editorial boards of nine international scientific journals. In addition, Dr. Dhillon has written 34 books on various aspects of reliability, design, safety, quality, and engineering management published by Wiley (1981), Van Nostrand (1982), Butterworth (1983), Marcel Dekker (1984), Pergamon (1986), etc. His books are being used in over 85 countries and many of them are translated into languages such as German, Russian and Chinese. He has served as General Chairman of two international conferences on reliability and quality control held in Los Angeles and Paris in 1987.

Professor Dhillon has served as a consultant to various organizations and bodies and has many years of experience in the industrial sector. At the University of Ottawa, he has been teaching reliability, quality, engineering management, design, and related areas for over 29 years and he has also lectured in over 50 countries, including keynote addresses at various international scientific conferences held in North America, Europe, Asia, and Africa. In March 2004, Dr. Dhillon was a distinguished speaker at the Conference/Workshop on Surgical Errors (sponsored by White House Health and Safety Committee and Pentagon), held at the Capitol Hill (One Constitution Avenue, Washington, D.C.). Professor Dhillon attended the University of Wales where he received a BS in electrical and electronic engineering and an MS in mechanical engineering. He received a Ph.D. in industrial engineering from the University of Windsor. e-mail: [dhillon@genie.uottawa.ca](mailto:dhillon@genie.uottawa.ca)

**Part I**  
**Research on the Man Character**

# Chapter 1

## Performance of Ergonomics from 2001 to 2012

Jie Li, Menglu Li, Xiaohong Guo and Aleksandar Jovanovic

**Abstract** The objective of this paper is to conduct a quantitative and qualitative analysis of the international journal of *Ergonomics*. Articles published in *Ergonomics* from 2001 to 2012 have been downloaded from the Science Citation Index-Expanded database. The bibliometrics methods have been used to analyse the publication output with respect to authors, countries, institutes and keywords of these documents. The results show that authors such as Van Dieen JH published the most papers in this journal; the analysis of institutes and countries has shown that Vrije University Amsterdam and USA are the most productive in each category. The analysis of the keywords revealed that “electromyography” has been the most-frequently author-used keywords, followed by “biomechanics”, “ergonomics” and “posture”, reflecting the hot topics and main attention of *Ergonomics*.

**Keywords** Scientometrics · Bibliometric · Ergonomics · Knowledge mapping

### 1.1 Introduction

The term “ergonomics” is derived from two Greek words “ergon”, meaning work, and “nomoi”, meaning natural laws (<http://www.ergonomics.org/>). These days, ergonomics has been applied in a variety of areas, including safety, computers, automobiles, cockpits, machinery and factories [1–4]. In addition, many

---

J. Li · A. Jovanovic (✉)  
Steinbeis Advanced Risk Technologies, Willi-Bleicher-Straße 19, 70174 Stuttgart, Germany

J. Li (✉) · X. Guo (✉)  
School of safety and Environmental Engineering, Capital University of Economics  
and Business, Beijing 100070, China  
e-mail: li.jie@risk-technologies.com

M. Li (✉)  
Auburn University, 3323 Shelby Building, Auburn, AL 36830, USA  
e-mail: mzl0049@auburn.edu



ergonomics-related journals and magazines are published around the world. In fact, there are totally 16 journals listed in the JCR 2012 (for more detailed information, please visit <http://blog.sciencenet.cn/blog-554179-752558.html>); these journals are all indexed by SSCI or SCI. *Ergonomics* is one of the most important journals in ergonomics topics which are published in England by Taylor and Francis Ltd and indexed by SCI and SSCI. According to the JCR Social Sciences Edition 2012, *Ergonomics* is 3 out of 16 in ergonomics journals and 23 out of 73 journals in psychology and applied. However, according to the JCR Science Edition 2012, *Ergonomics* is 9 out of 44 in categories of engineering, industrial, and 47 out of 75 in the subject categories of psychology. *Ergonomics* has an impact factor of 1.674 in 2013. Recently, the research shows that bibliometrics methods have become an effective way to analyse the performance of Journals [5–7]. In this study, scientometrics method was used to help outline a profile of the *Ergonomics* from 2001 to 2012, including annual distribution of articles, authors, institutes, countries and keywords of the journal.

## 1.2 Data and Method

The data were retrieved on 30 August 2013, from the Science Citation Index-Expanded (SCI-E) database with an online version published by Thomson Reuters, which has been operated by Thomson Scientific, Philadelphia, PA, USA. The retrieval strategies were arranged as Publication Name = (*Ergonomics*), Time span = (2001–2012). Totally, 1544 documents, including articles (1289, 83.484 %), book reviews (177, 11.464 %), proceedings papers (81, 5.246 %), editorial materials (35, 2.267 %), reviews (22, 1.425 %), corrections (12, 0.777 %) and biographical items (8, 0.518 %), have been published in *Ergonomics*. As articles represented the majority of peer-reviewed document in the journal, therefore, 1,289 articles were downloaded for further analysis (including 81 proceedings articles published in *Ergonomics*). The bibliometrics method has been used in this study which includes basic statistics, geographic distribution and co-words analysis. Also, tools for scientometrics analysis including Histcite [8], VOSviewer [9] and SATI [10] have been used for the data analysis.

## 1.3 Results and Discussion

### 1.3.1 Publication Output

Articles published in *Ergonomics* from 2001 to 2012 are shown in Fig. 1.1. The number of papers published annually in the journal of *Ergonomics* varies from 68 to 129 and the average number of papers published in *Ergonomics* is more than

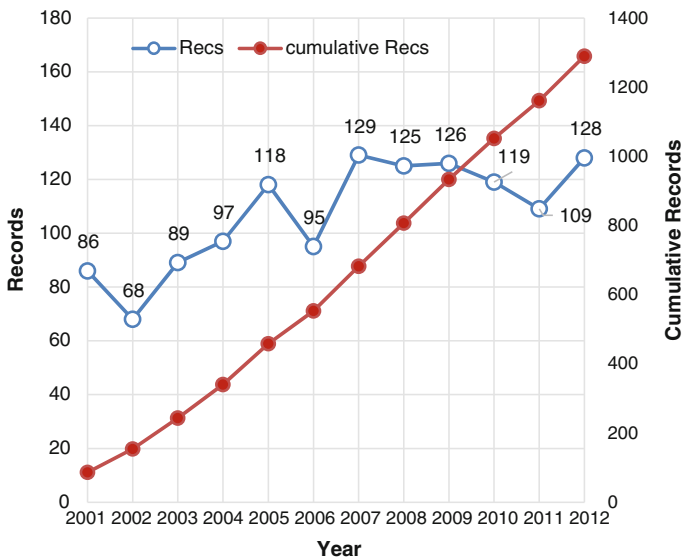


Fig. 1.1 Annual distribution of articles published in *Ergonomics* from 2001 to 2012

107, with standard deviation of 20.02. As a monthly journal, the papers published in *Ergonomics* did not change significantly over time.

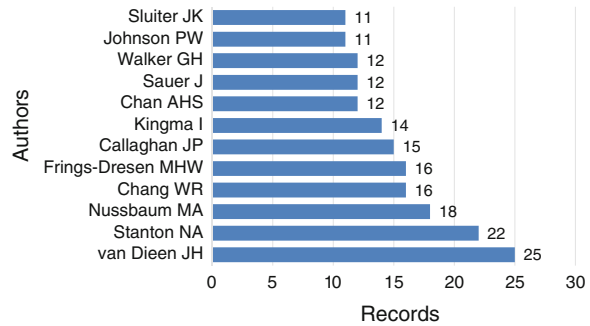
### 1.3.2 Authors' Analysis

There are 3,039 authors from all the 1,289 articles. The top 10 most productive authors are displayed in Fig. 1.2. Out of 3,039 authors, Van Dieen JH has contributed the most number with 25 articles ranking the first place, followed by Stanton NA (22), Nussbaum MA (18), Chang WR (16), Frings-Dresen MHW (16), Callaghan JP (15), Kingma I (14), Chan AHS (12), Sauer J (12), Walker GH (12), Johnson PW (11) and Sluiter JK (11). They are all core authors who have published articles in *Ergonomics*.

### 1.3.3 Institute Analysis

The contributions of different institutes were assessed herein by the institutes' affiliations with at least one author in the published papers. The top 20 institutes with a paper quantity of more than 15 are ranked by the number of their published articles. According to Table 1.1, Vrije University Amsterdam has published 40 articles, ranking first, followed by University Waterloo with 37 articles, and

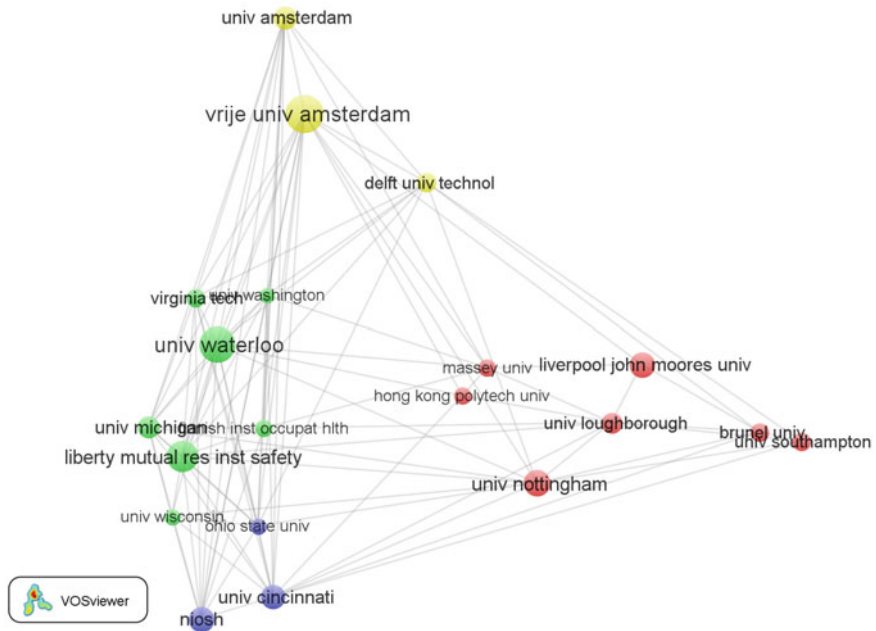
**Fig. 1.2** Top 10 most productive authors of *Ergonomics* during 2001–2012



**Table 1.1** Top 20 most productive Institutes of *Ergonomics* during 2001–2012

No.	Institution	Country	Recs	Percentage	LCS	GCS
1	Vrije University Amsterdam	Netherlands	40	3.1	67	542
2	University Waterloo	Canada	37	2.9	62	376
3	Liberty Mutual Res Inst Safety	USA	32	2.5	25	193
4	University Nottingham	UK	28	2.2	64	397
5	Liverpool John Moores University	UK	27	2.1	12	438
6	NIOSH	USA	26	2	64	452
7	University Cincinnati	USA	25	1.9	45	273
8	University Amsterdam	Netherlands	24	1.9	31	320
9	University Michigan	USA	23	1.8	46	217
10	University Loughborough	UK	22	1.7	40	202
11	Delft University Technol	Netherlands	21	1.6	18	180
12	University Southampton	UK	20	1.6	24	105
13	Brunel University	UK	19	1.5	84	295
14	Virginia Tech	USA	19	1.5	12	92
15	Finnish Inst Occupat Hlth	Finland	18	1.4	80	442
16	Hong Kong Polytech University	China	18	1.4	30	157
17	Massey University	New Zealand	18	1.4	32	178
18	Ohio State University	USA	17	1.3	31	152
19	University Wisconsin	USA	17	1.3	24	158
20	University Washington	USA	16	1.2	54	252

Note Rec is number of the articles, Percentage is percentage of articles, LCS is local citation score, which means the number of cited times cited by other papers in local database. GCS is global citation score that means the number of cited times cited by other papers in web of science (until 30 August 2013)



**Fig. 1.3** Bibliographic coupling of key institutions in *Ergonomics*

Liberty Mutual Res Inst Safety with 32 article ranking third that makes up the three of the most powerful institutions in *ergonomics*. The GCS of the Vrije University Amsterdam (542) also is the highest, followed by NIOSH (452), Finnish Inst Occupat Hlth (442) and Liverpool John Moores University (438). Moreover, Finnish Inst Occupat Hlth (24.5) has the highest AVGS, followed by NIOSH (17.4) and Liverpool John Moores University (16.2), are the leading institutes in paper quantity.

The VOSviewer software has been used to analyse the bibliographic coupling of the 20 most productive institutions (see in Fig. 1.3). From the software, four major clusters of institutions have been generated. Cluster 1 includes Brunel Univ, Hong Kong Polytech Univ, Liverpool John Moores Univ, Massey Univ, Univ Loughborough, Univ Nottingham and Univ Southampton; the cluster 2 includes Finnish Inst Occupat Hlth, Liberty Mutual Res Inst Safety, Univ Michigan, Univ Washington, Univ Waterloo, Univ Wisconsin and Virginia Tech. The cluster 3 includes Niosh, Ohio State Univ and Univ Cincinnati; the cluster 4 includes Delft Univ Technol, Univ Amsterdam and Vrije Univ Amsterdam. Institutions in same cluster have more cooperation and the close ergonomics topics. The institutes of Vrije University Amsterdam, University Waterloo, Liberty Mutual Res Inst Safety, University of Nottingham, Liverpool john Moores University, NIOSH and University of Cincinnati are in the core status of correspondent cluster. Furthermore, institutions including Vrije University Amsterdam, University of Waterloo,



**Fig. 1.4** The spatial distribution of *Ergonomics* papers during 2001–2012. To explore the map in an interactive way, please visit: <https://www.google.com/fusiontables/DataSource?docid=15CoDtAs5PEscK7Zgae9Y9m9yq2MVVHoDr5Tuoec8>

Liberty Mutual Res Inst Safety, University of Nottingham and NIOSH have cooperated with other institutes frequently and have an important role in their cluster group.

### 1.3.4 Spatial Distribution Analysis

The outputs of different countries or territories are presented in Fig. 1.4, and the detailed information of top 10 countries are listed in Table 1.2. The most productive country is USA, followed by UK, Canada and the Netherlands. Furthermore, these countries also have the high citation rates that have been evaluated by TLCS and TGCS. Finland ranked the first place when compared in terms of AGCS (AGCS is the average citation frequency of article, which implies the quality of the articles). It means that these countries/territories published the most high-quality papers in this journal and have the highest strength in ergonomics research. The number of publications in other countries is all below 100.

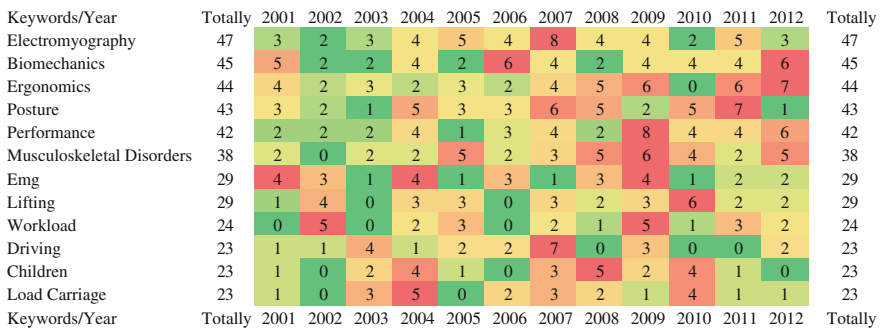
### 1.3.5 Keywords Research

In this part, Statistical Analysis Toolkit for Informetrics<sup>1</sup> (SATI) has been used to analyse the frequency of the keywords and make the  $100 \times 100$  Co-occurrence matrix (Valued) of the *ergonomics* keywords. Keywords matrix has been used in

<sup>1</sup> Statistical Analysis Toolkit for Informetrics can freely get from <http://sati.liuqiyan.com/>.

**Table 1.2** Top 10 most productive countries/territories of *Ergonomics* papers during 2001–2012

No.	Country	Recs	Percentage	TLCS	TGCS	AGCS
1	USA	368	28.5	613	3,608	9.80
2	UK	230	17.8	383	2,726	11.85
3	Canada	129	10	195	1,100	8.53
4	the Netherlands	104	8.1	146	1,266	12.17
5	Australia	97	7.5	141	862	8.89
6	Sweden	63	4.9	152	878	13.94
7	Germany	56	4.3	79	463	8.27
8	Peoples R China	51	4	70	381	7.47
9	New Zealand	39	3	53	328	8.41
10	France	38	2.9	46	301	7.92



**Fig. 1.5** Annual distribution of the keywords in *Ergonomics*

Ucinet to get NET file, and Gephi<sup>2</sup> was used to draw the network of the keywords distribution. The most-frequent keywords and their annual distribution are displayed in Fig. 1.5. The high-frequency words including “electromyography (47)”, “biomechanics (45)”, “ergonomics (44)”, “posture (43)”, “performance (42)”, “musculoskeletal disorders” (38), “EMG (29)”, “lifting (29)”, “workload (24)”, “driving (23)”, “children (23)” and “load carriage (23)” are shown in the Fig. 1.5. These high-frequency keywords are reflecting the main topics which Ergonomics focus on. In addition, Fig. 1.5 also reveals that “electromyography” and “driving” were the hot research topics in 2007; “performance” was a hot topic in 2009; “posture” is a hot topic in 2011; “biomechanics” is a hot topic in 2006 and 2012. Each word demonstrates the trend of different research areas in *Ergonomics*. From the network of the keywords in journal of Ergonomics (See Fig. 1.6), it has been

<sup>2</sup> The Open Graph Viz Platform can freely get from <https://gephi.org/>.

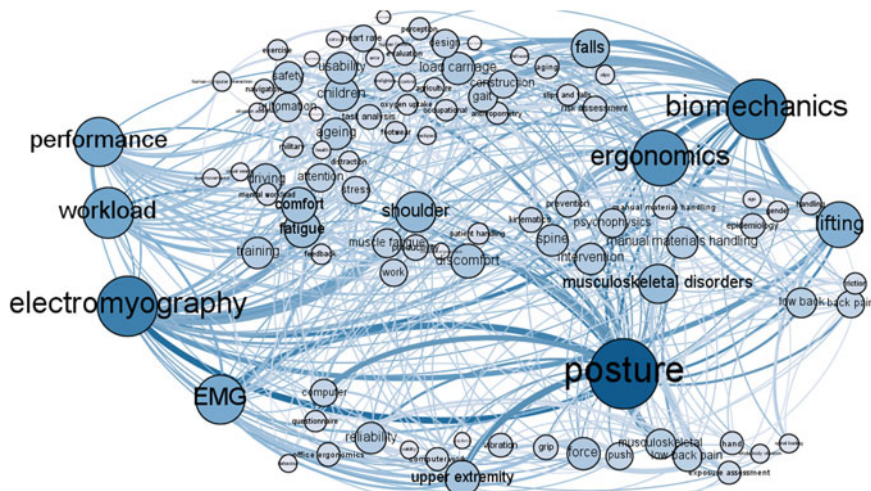


Fig. 1.6 Network of the keywords in journal of *Ergonomics*

shown that “electromyography”, “biomechanics”, “ergonomics”, “posture”, “performance”, “musculoskeletal disorders”, “EMG”, “lifting”, “workload” and “driving” have a high degree in the network. It means these keywords have played an important role in connection with each topic in *Ergonomics*.

## 1.4 Conclusions

In this study, bibliometrics methods have been used to analyse the performance of the journal of *Ergonomics* from 2001 to 2012. The results of publications outputs, authors, countries/territories, institutes and keywords distribution are explained in this paper. The analysis of the authors shows that Van Dieen JH, Stanton NA, Nussbaum MA and Chang WR are the most productive authors who publish more articles in *Ergonomics*. The articles published in *Ergonomics* reveal that Vrije University Amsterdam, University Waterloo and Liberty Mutual Res Inst Safety are the key institutes. Moreover, USA, UK, Canada and the Netherlands are the most productive countries. Finally, keywords of “electromyography (47)”, “biomechanics (45)”, “ergonomics (44)”, “posture (43)”, and “performance (42)” are the hot topics, which are the *Ergonomics*’ focus.

**Acknowledgment** The study has been supported by the Joint Education Graduate Cooperation Program between Capital University of Economics and Business (CUEB) and Steinbeis Advanced Risk Technologies.

## References

1. Chaffin DB (1975) Ergonomics guide for the assessment of human static strength. *Am Ind Hyg Assoc J* 36(7):505–511
2. Turner JA, Karasek RA Jr (1984) Software ergonomics: effects of computer application design parameters on operator task performance and health. *Ergonomics* 27(6):663–690
3. Hendrick HW (1991) Ergonomics in organizational design and management. *Ergonomics* 34(6):743–756
4. Wilson JR (1997) Virtual environments and ergonomics: needs and opportunities. *Ergonomics* 40(10):1057–1077
5. Arunachalam S, Markanday S (1981) Science in the middle-level countries: a bibliometric analysis of scientific journals of Australia, Canada, India and Israel. *J Inf Sci* 3(1):13–26
6. Ramos-Rodríguez AR, Ruíz-Navarro J (2004) Changes in the intellectual structure of strategic management research: a bibliometric study of the strategic management journal, 1980–2000. *Strateg Manag J* 25(10):981–1004
7. Wang M-H, Yu T-C, Ho Y-S (2010) A bibliometric analysis of the performance of water research. *Scientometrics* 84(3):813–820
8. Garfield E (2009) From the science of science to scientometrics visualizing the history of science with HistCite software. *J Informetr* 3(3):173–179
9. Van Eck NJ, Waltman L (2010) Software survey: VOSviewer, a computer program for bibliometric mapping. *Scientometrics* 84(2):523–538
10. Liu Q, Ye Y (2012) A study on mining bibliographic records by designed software SATI: case study on library and information science. *J Inf Res Manage* 1:50–58



## Chapter 2

# Perceived Fatigue Evaluating Model in Health Men Performing Backpack Load-Carriage Exercises

Yuhong Shen, Jiewen Zheng, Chenming Li, Yafei Guo  
and Pengfei Ren

**Abstract** *Objectives* This study aimed to develop a fatigue model for human load carriage during endurance exercise using quantification of perceived pains and physiological parameters. *Methods* Heart rate, skin contact pressure, and perceived pains and corresponding locations of five healthy participants were measured during treadmill tests on non-consecutive days under three different conditions of backpack payloads (29, 31.5, and 34 kg). *Results* All participants could complete the trials without resting using 29, 31.5, and 34 kg payloads for 50 min. The slopes for heart rate regression equations in three-payload conditions became steeper as the payload increased. The trends of root mean square (RMS) of skin contact pressure in back, shoulder, and hip regions are all changing smoothly. But the overall amplitudes of RMS of pressure in shoulder region in all three-payload conditions are higher comparing with other two regions. Perceived fatigue intensity results showed that shoulder region was the most discomfort region on the body and was highest using 34-kg payload. *Conclusions* The results suggested that shoulder fatigue may limit endurance performance, thereby indicating the importance of a well-designed shoulder strap. A fatigue intensity predictive model was proposed to allow prediction of human load carriage limits and fatigue intensity trend for endurance exercise.

**Keywords** Backpacks · Biomechanical assessment · Load carriage · Fatigue intensity predictive model · Skin contact pressure

---

Y. Shen · J. Zheng (✉) · C. Li · Y. Guo · P. Ren  
The Quartermaster Research Institute of the General Logistic Department,  
Beijing 100010, China  
e-mail: jaroncheng@126.com

## 2.1 Introduction

Backpacks or personal load carriage systems are commonly used by soldiers to carry heavy loads in different terrains and gradients even in long-distance marching or in the fighting [1]. With technological advancements, loads carried by soldiers especially in terms of increased firepower and protection equipments have progressively increased. Unfortunately, carrying heavy loads often caused discomfort, fatigue, and injuries and affecting soldiers' operational performance [2]. In a recent military report, US rifle squads carried fighting load of 28.3 kg (34.9 % body weight (BW)), approach march load of 43.1 kg (52.6 % BW), and emergency approach march load of 58.2 kg (73.6 % BW) [3]. A difficulty for military personnel have to face is to assess the fatigue or injury that various loads will have on foot soldiers. Even though payload and mission are known, there are only a few strategies to assess or predict the impact of loads on the soldiers. It is important to develop a predictive model or equation that encompasses more of the major variables that limit performance of load carriage in the field.

Till date, the studies of fatigue predictive model for human load carriage particularly in military conditions are limited and less reported, especially applying both biomechanical and physiological approaches. This paper will explore the relationships between fatigue and backpacks and give some suggestions for improving the design of backpack and reducing discomfort or fatigue when carrying heavy loads. Finally, a fatigue intensity predictive model was proposed to allow prediction of human load carriage limits and fatigue intensity trend for endurance exercise, which would be used to provide backpackers and military with a simple guideline to assess the load reasonably carried by a soldier or backpacker, the duration with corresponding load, and the dropout rate for a certain task.

## 2.2 Methods

### 2.2.1 Subjects

Five male individuals with a mean ( $\pm$ SD) age, body weight, and height of  $24.2 \pm 3.7$  years,  $64.5 \pm 11.59$  kg, and  $172.2 \pm 2.39$  cm, respectively, enrolled in this study. The participants were healthy Chinese men and had no muscular or skeletal illness that would influence load carriage performance. Both written consent and verbal consent were obtained from all participants prior to experiment. They were asked to have a good rest and avoid caffeine, alcohol, smoking, and intense physical activity at least 24 h prior to the experiment.

### 2.2.2 Apparatus and Measurements

The pressures at shoulder, back, and hip regions were measured by miniature pressure sensor (Model 9801, Tekscan, USA). The 9801 sensor has sensing region dimension of  $7.6 \times 20.3$  cm that is so small that a minimal change to the curvature of the shoulder strap can be measured. Two 9801 sensor pads were put on each region to detect pressure of both sides, as shown in Fig. 2.1. Each 9801 sensor was plugged into a data scanner where pressure data were collected and sent to PC via USB cable where the data can be viewed, analyzed, and stored in real time with I-Scan<sup>®</sup> application software. Heart rate (HR) was acquired using a chest HR belt and a wristwatch monitor (S610i, Polar, Finland). The HR data stored in wristwatch monitor will be uploaded to PC via infrared port after experiment.

### 2.2.3 Procedure

The experimental trials began at 08:00. Temperature of the climate chamber was maintained at 25 °C throughout all the trials. Participants visited the climate chamber at our institute for three exercise sessions on non-successive days. The payloads were packed into the modern Chinese army backpack that was adjusted to fit each participant with a balanced and uniform load distribution. Five participants will perform treadmill tests (5 km/h speed, 0 % incline) under three

**Fig. 2.1** Location of 9801 pressure sensors



different conditions (29, 31.5, or 34 kg). Every three minutes, numerical fatigue intensity (0 to 10 where “0” indicates “no fatigue” and “10” indicates “fatigue as bad as it can be”) on three regions (shoulder, back, and hip) and whole body were recorded by the researcher, until finishing 50 min of trail or until the participant reported stopping exercising.

### 2.2.4 Statistics

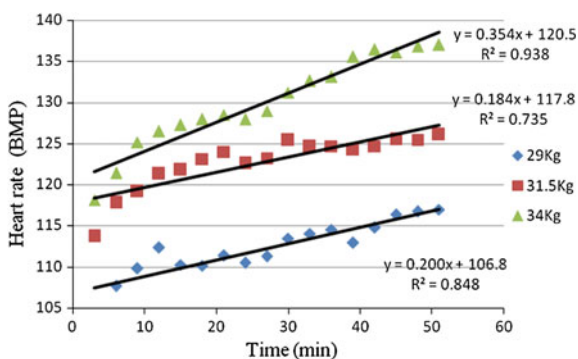
Descriptive statistics were used to calculate mean values for fatigue intensity. The root mean square (RMS) was used to describe the magnitude of skin contact pressure in three minutes.  $P < 0.05$  was considered significant. All statistical analyses were performed in SPSS 11.0 and MATLAB 7.0.

## 2.3 Results

Figure 2.2 shows the mean HR resulting from 50 min of load carriage on a treadmill for three payloads. In Fig. 2.2, the regression equation for each payload was calculated based on time (independent variable) and mean HR (dependant variable). The slope for regression equation became steeper as the payload increased. Figure 2.2 also shows that mean HRs generally reached a plateau (slopes became gentle) between 25 and 40 min of exercise.

Figure 2.3 shows the RMS of skin contact pressure during 50 min of load carriage exercise for three payloads. It can be seen that the trends of RMS of skin contact pressure in back, shoulder, and hip regions in three-payload conditions are all changing smoothly. But the overall amplitudes of RMS of pressure in shoulder regions are higher comparing with other two regions (back and hip). And the difference is most obvious in 34 kg payload.

**Fig. 2.2** Mean HR during 50 min of load carriage exercise



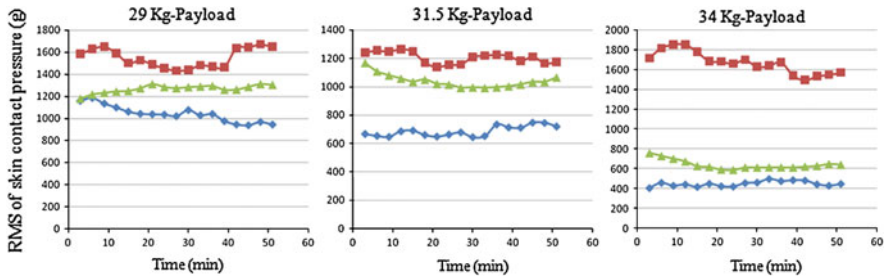


Fig. 2.3 The RMS of skin contact pressure during 50 min of load carriage exercise

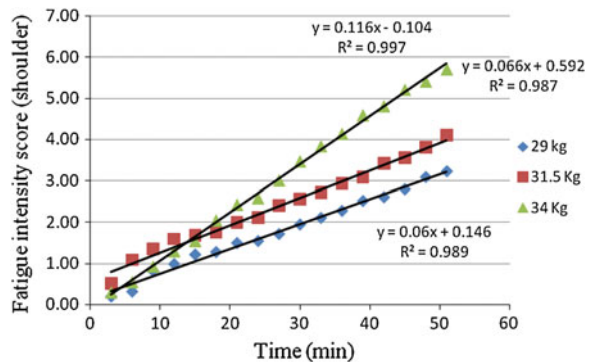
Table 2.1 Perceived fatigue score of shoulder, back, and hip regions and whole body in three-payload conditions

Time	Shoulder			Back			Hip			Whole body		
	29 kg	31.5 kg	34 kg	29 kg	31.5 kg	34 kg	29 kg	31.5 kg	34 kg	29 kg	31.5 kg	34 kg
50 min	3.2	4.1	5.7	3.3	2.1	1.3	3.1	2.3	3.7	3.6	3.3	3.9

Table 2.1 shows perceived fatigue scores of three regions and whole body during 50 min exercises in three-payload conditions. In shoulder and hip regions, the fatigue scores increased as the payloads changing from 29 to 34 kg. But the opposite is in back region. Whereas there is no regular changes of the whole body fatigue score. Table 2.1 also shows that shoulder region was the most discomfortable region on the body and was highest using 34-kg payload.

To develop fatigue predictive model for load carriage, a number of regression equations were calculated. Figure 2.4 shows the regression equations for each payload, calculated based on fatigue scores from the most discomfortable of shoulder region (dependent variable) and time (independent variable). Figure 2.5 shows the regression equations, calculated based on shoulder fatigue (dependent

Fig. 2.4 The relationship between shoulder region fatigue and excising time during load carriage



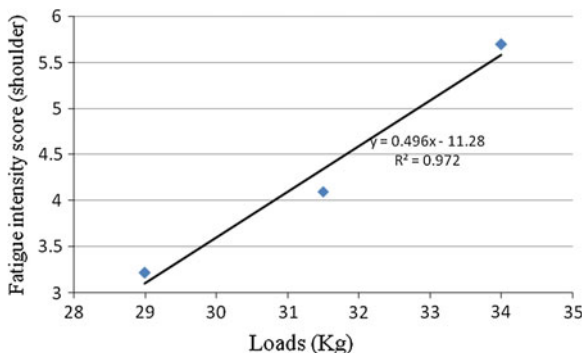


Fig. 2.5 The relationship between shoulder region fatigue and payload during load carriage

Model 1 Prediction of load carriage duration for discrete payloads ≤ 34 kg	Model 2 Prediction of percent of maximal fatigue intensity for a given payload during 50-minute exercise.
<p>If payload is known (e.g. 29, 31.5, 34 kg), then the maximal duration can be predicted. Choose appropriate regression equation from Figure 4; Where, x = time; y = shoulder fatigue score. <b>For example:</b> To predict how long backpacker can endure 31.5 kg before fell exhausted. <math>y = 0.066x + 0.592</math>; (31.5 kg), when <math>y = 5.7</math>, <math>x = 77</math> minutes; Therefore, backpacker can endure 77 minutes exercise when carrying 31.5 kg payload.</p>	<p>If the payload is known, then the percent of maximal fatigue intensity can be predicted. <b>Step 1:</b> Use equation from Figure 5: <math>y = 0.496x - 11.28</math> Where, x = load; y = shoulder fatigue intensity. <b>Step 2:</b> Use following equation: % maximal fatigue limit: = <math>y/5.7 \times 100\%</math>. <b>For example:</b> If 33 kg payload is carried for 50 minutes, backpacker will be working at the following percent of his maximal fatigue limit. <b>Step 1:</b> <math>y = 0.496 \times 33 - 11.28</math> <math>y = 5.1</math> <b>Step 2:</b> % maximal fatigue limit: = <math>5.09/5.7 \times 100\% = 89.3\%</math> Therefore, fatigue is predicted to be 5.1/10 during payload carriage of 33 kg for 50 minutes which is 89.3% of maximal load carriage fatigue limit.</p>

Fig. 2.6 The fatigue intensity predictive model

variable) and payload (independent variable). For this test, all participants could complete 50-min exercises without resting using all three payloads.

Based on above findings, a simple fatigue predictive model will be proposed (Fig. 2.6).

## 2.4 Discussions

As expected, each participant showed increasing tendency of mean HR in all three-payload conditions and reached a plateau between 25 and 40 min (Fig. 2.2). When starting exercise, the cardiorespiratory system is trying to accommodate body to changed load conditions, so the HR increased rapidly. After about 25 to 40 min, the body tends to balance, so a plateau appeared. But the HR would continue to grow up as the exercising intensity increased, and then, the body would explore potential of the body to adapt to new change [4]. The highest mean HR recorded was 137 beat/min (BPM) (34-kg payload), suggesting that the HR was in the low end of cardiorespiratory limit. Tanaka et al. reported that following equation could be used to predict maximal HR (HRmax):  $HR_{max} = 208 - (0.7 \times \text{age})$  [5]. Based on mean age of our participants (24.2 year), the expected HRmax would be 191 BPM. From Fig. 2.2, it can be calculated that the participants were exercising at 71.1 % of HRmax (34 kg). Kenney et al. reported that about 70 % of HRmax could be accepted for most healthy individuals [6]. Based on above, all participants always took exercises within maximal cardiorespiratory limit, even for the heaviest 34-kg payload, suggesting that HR may be not a major factor for predicting fatigue when carrying under 34-kg payload.

Some studies have suggested that the shoulder region played the most important role in determining load carriage limit and will be most vulnerable region of feeling fatigue or pain [7, 8]. This study gets similar results that both in 31.5- and 34-kg payloads condition, fatigue scores of shoulder region are the biggest. But in 29-kg payload, the most discomfortable region was back. Table 2.1 shows that fatigue scores of the shoulder, back, and hip regions in 29-kg payload were 3.2, 3.3, and 3.1, respectively, suggesting the differences between them had no significances ( $P > 0.05$ ). This maybe can be explained that perceived fatigues in three regions are so small in this low payload condition (29 kg) that it cannot be differentiated. In all payloads conditions, fatigue score of shoulder region in 34 kg was highest, suggesting that shoulder fatigue may limit endurance performance, thereby indicating the importance of a well-designed shoulder strap. The sternum strap and hip belt may also improve fatigue by reducing shoulder pressure through the redistribution forces over a larger surface on the anterior body during endurance exercise. These results are similar to other studies [1, 9, 10].

Figure 2.3 shows the RMS of pressure in shoulder region in all three-payload conditions are higher than other regions, but almost no differences existed among three-payload conditions. By contrast, the RMS of pressure in back and hip regions seemed to present regular trends of increasing as adding payloads. It was possible that the sternum strap and hip belt shared much pressures distributed in shoulder region when payload increased. So that is why the RMS of pressure in shoulder had less change, whereas those of back and hip increased. This also on the other hand proved that well-designed sternum strap and hip belt would improve back-pack performance in load carriage and proved the backpack used in this study had good performance. The skin contact pressures could be acquired with film-type

sensors, but some indeterminacy due to volatile contact areas between skin and backpacks, bending errors, poor repeatability, and calibration limitations still existed [11]. So modern pressure mapping technology must resolve these problems or explore alternative methods to study biomechanical factors in load carriage. As such, using two 3-axis accelerometers to assess the contact forces and pressures between the backpack and person seems to be a prosperous method [12].

Some limitations of our studies must be pointed out. First, payload or duration should be increased. In this study, the maximum payload was 34 kg, 52.7 % of BW. But Fig. 2.4 shows that the maximal mean fatigue score was only 5.7 in shoulder region. It was obvious that the participants did not reach their physical limits. US army defined the limit of payload in load carriage was 50 kg based on previous statistical data acquired from Afghanistan and the Falkland Islands battles. Second, the number of participants was small ( $N = 5$ ). It was important to have a dropout rate in order to develop a comprehensive fatigue predictive model through increasing samples, payloads, or duration of exercise. Third, this study tested a limited payloads (29, 31.5, 34 kg), march speed (5 km/h), incline (0 %), and duration (50 min). Only when testing wide conditions, the predictive model could have good performance in actual application.

## 2.5 Conclusion

A fatigue intensity predictive model was proposed to allow prediction of human load carriage limits and fatigue intensity trend for endurance exercise. The fatigue predictive model only considering limited physiological and biomechanical aspects. But more factors should be introduced, such as demographic factor including body size, gender, and age, fitness and injury factors, and so on. In this paper, the study on fatigue predictive model is only elementary and groping, and a lot of work need to do in the future.

## References

1. Knapik JJ, Reynolds KL, Harman E (2004) Soldier load carriage: historical, physiological, biomechanical, and medical aspects. *Mil Med* 169(1):45–56
2. Roy TC, Knapik JJ, Ritland BM et al (2012) Risk factors for musculoskeletal injuries for soldiers deployed to Afghanistan. *Aviat Space Environ Med* 83(11):1060–1066
3. Coalition Task Force 82, Coalition Joint Task Force 180 (2010) *The modern Warrior's combat load: dismounted operations in Afghanistan*. CreateSpace Independent Publishing Platform, Seattle
4. Wenger HA, Bell GJ (1986) The interactions of intensity, frequency and duration of exercise training in altering cardiorespiratory fitness. *Sports Med* 3(5):346–356
5. Tanaka H, Monahan KD, Seals DR (2001) Age-predicted maximal heart rate revisited. *J Am Coll Cardiol* 37(1):153–156



6. Kenney WL, Wilmore JH, Costill D (2011) *Physiology of sport and exercise*, 5th edn. Human Kinetics, Champaign
7. Holewijn M, Meeuwssen T (2001) Physiological strain during load carrying: effects of mass and type of backpack. Technical Report. ADP010987
8. Whiteside RA, Doan JE, Reid SA et al (1999) Integrated patrol pack and rucksack development phase IIIB: performance testing of suspension components. DCIEM-CR-2001-087
9. Holewijn M (1990) Physiological strain due to load carrying. *Eur J Appl Physiol Occup Physiol* 61(3-4):237-245
10. Knapik J, Harman E, Reynolds K (1996) Load carriage using packs: a review of physiological, biomechanical and medical aspects. *Appl Ergon* 27(3):207-216
11. Hadcock LJ, Bryant JT, Stevenson JM (2002) Pressure and force distribution measurement for the design of waist belts in personal load carriage systems. Contract#W7711-0-7632-02/A
12. Morin EL, Stevenson JM, Reid SA et al (2005) Development of a dynamic biomechanical model for load carriage: phase V—development of the biomechanical model by means of the portable measurement system. ADA480769

# Chapter 3

## The Changes of Physiological and Biomechanical Indices and Their Relations to Fatigue During Treadmill Walking with Different Loads

Jiewen Zheng, Yuhong Shen, Chenming Li, Pengfei Ren and Yafei Guo

**Abstract** *Objectives* To analyze the changes of physiological and biomechanical signals and their relations to fatigue in treadmill walking with backpack load. *Methods* Cardiopulmonary function parameters, shoulder force, trunk pressure, and perceived fatigues are sampled simultaneously with six healthy men during 30-min treadmill walking experiments under five different conditions of backpack loads. *Results* HR, BR, VE, and VO<sub>2</sub> gradually increased as the load increased, and the increasing rate became bigger during 37–39 kg tests. Shoulder force and shoulder pressure were strongly correlated with load. Pressures at waist and back regions were influenced by the tension degree of waist and chest belts. The 37-kg load was the turning point of human cardiopulmonary function starting working overload. The perceived fatigues in shoulder and whole body are more intense than those of back and waist. *Conclusions* The coordinate ability of cardiopulmonary system should be considered when studying treadmill walking with loads greater than 37 kg. Shoulder force and pressure are considered as main factors for fatigue evaluation.

**Keywords** Backpack · Load carriage · Perceived fatigue · Physiological signals · Biomechanical signals

---

J. Zheng · Y. Shen (✉) · C. Li · P. Ren · Y. Guo  
The Quartermaster Research Institute of the General Logistic Department,  
Beijing 100010, China  
e-mail: yuhong810@aliyun.com

## 3.1 Introduction

Carrying heavy loads for long distances is a common requirement to military personnel, various types of workers, and recreational hikers [1]. With technological advancements, loads carried by people especially for soldiers in terms of increased firepower and protection equipments have progressively increased. Physical transport of heavy load over long distances often caused discomfort, fatigue, and injuries and affecting soldiers' operational performance [2–4]. In a recent military report, U.S. rifle squads carried fighting load of 28.3 kg (34.9 % body weight (BW)), approach March load of 43.1 kg (52.6 % BW), and emergency approach March load of 58.2 kg (73.6 % BW) [5]. Even though U.S. Army has been attempting to reduce loads carried by soldiers, little effects were obtained for maintaining requirements of combat. According to statistics of U.S. Army, there were 257,000 cases of injuries in lower extremity induced by overload combat equipments in 2007. Thus, it is very significant to study relative factors leading to fatigues and injuries by various load–condition experiments. At present, many researchers have done much works related to load carriage applying with physiological and biomechanical methods, such as to analyze forces distributed in trunk regions using pressure sensors, to study effects of load carriage on kinematics of gait using human motion detecting system [4, 6, 7]. Many load carriage relevant works have been done in China, but most of them only applied heart rate (HR), body temperature, oxygen uptake (VO<sub>2</sub>), and other physiological variables to study optimal load for single soldiers and to evaluate load carriage systems [8–10]. The characteristics of physiological and biomechanical signals during different-load treadmill walking and their relationships with perceived fatigues have not been studied so far. The purpose of this study was to systematically analyze the characteristics and trends of HR, breathing rate (BR), VO<sub>2</sub> and other physiological parameters, forces on shoulder, back and waist regions, and perceived fatigues during different-load conditions, and to explore relative factors leading to body fatigue.

## 3.2 Methods

### 3.2.1 Subjects

Six male individuals with a mean ( $\pm$ SD) age, body weight, and height of  $24.7 \pm 3.5$  year,  $63.8 \pm 8.3$  kg,  $172.0 \pm 2.3$  cm, respectively, enrolled in this study. The participants were healthy Chinese men and had no muscular or skeletal illness that would influence load carriage performance. Both written and verbal consent were obtained from all participants prior to experiment. They were asked to have a good rest and avoid caffeine, alcohol, smoking, and intense physical activity at least 24 h prior to the experiment.

### 3.2.2 Apparatus and Measurements

The pressures at shoulder, back, and waist regions were measured by miniature pressure sensor (Model 9801, Tekscan, USA). The 9801 sensor has sensing region dimension of  $7.6 \times 20.3$  cm that is so small that a minimal change to the curvature of the shoulder strap can be measured. Two 9801 sensor pads were put on each region to detect pressure of both sides, as is showed in Fig. 3.1. Each 9801 sensor was plugged into a data scanner where pressure data were collected and sent to PC via USB cable where the data can be viewed, analyzed, and stored in real time with I-Scan<sup>®</sup> application software. Two pulling force sensors are placed on both sides of shoulder straps; the data were transferred to PC via RS-232 port for real-time display and record. HR and BR were acquired using the physiological monitoring straps called Bioharness 3 (Zephyr, USA); the data were wirelessly sent to PC via Bluetooth 3.0. VO<sub>2</sub> and VE were continuously measured via a face mask using on-line gas analysis (Fitmate Pro, Cosmed, Italy).

### 3.2.3 Procedure

Temperature of the climate chamber was maintained at  $25 \pm 2$  throughout all the tests. Participants visited the climate chamber at our institute for five exercise sessions on non-successive days (at least one-day interval). At each exercise session, subjects were randomly assigned to carry one of the following loads: 25,



**Fig. 3.1** The positions of pressure sensors and shoulder straps pulling forces sensors

29, 34, 37, or 39 kg. The loads were packed into a modern Chinese army backpack that was adjusted to fit each subject with a balanced and uniform load distribution. The test was conducted in a treadmill (LE 600 CE, Jaegher, Germany) (5 km/h speed, 0 % incline). Every 3 min, scores of perceived fatigues (0 to 10, where “0” indicates “no fatigue” and “10” indicates “fatigue as bad as it can be”) on three local regions (should, back, waist) and whole body were recorded by the researcher, until finishing 30 min of trail or participants reported stopping exercising.

### ***3.2.4 Statistics***

Descriptive statistics were used to calculate mean, SD, and other general information. One-way ANOVA and repeated measures were used to analyze the relationships between various variables during different-load conditions.  $P < 0.05$  was considered significant. All statistical analyses were performed in SPSS 11.0 and Matlab 7.0.

## **3.3 Results**

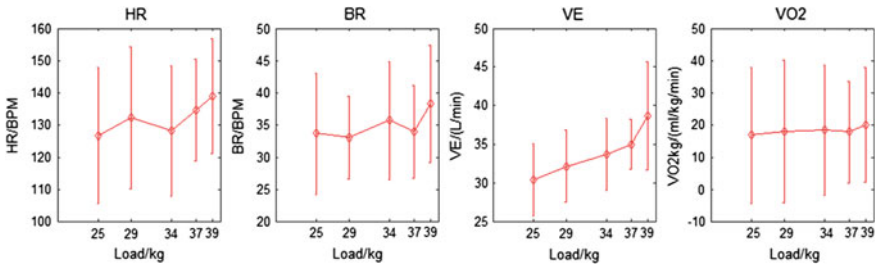
The six subjects completed all five-load conditions, 30-min treadmill walking. At the end of experiment, no subjects report dizziness, nausea, and other over-fatigue symptoms. Table 3.1 gives the means and SD for physiological, biomechanical, and scores of perceived fatigue contrasted by five-load conditions.

### ***3.3.1 Physiological Signals***

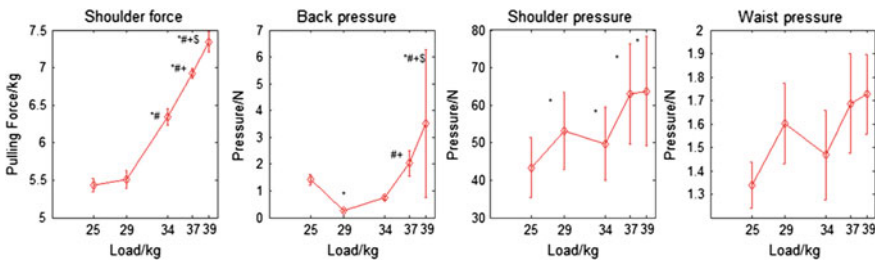
Figure 3.2 depicts the developing trends of HR, BR, VE, and VO<sub>2</sub> during different-load conditions. The four physiological parameters gradually went up when load increased from 25 to 39 kg, and the raising speed became quicker in 37–39-kg tests than others, but no significant differences were observed. HR irregularly changed in 25–34-kg tests, but speed up in 34–39-kg tests. BR gently changed in 25–37-kg tests, but became obvious quicker in 37–39-kg tests. VE and VO<sub>2</sub> presented steady uptrend and became quicker in 37–39-kg tests.

**Table 3.1** Descriptive statistics for exercise data under different-load condition (Mean  $\pm$  SD)

Load (kg)	HR (BPM)	BR (BPM)	VE (L/min)	VO <sub>2</sub> (ml/kg/min)	Should force (kg)	Back pressure (N)	Shoulder pressure (N)	Waist pressure (N)	Shoulder PRE	Back PRE	Waist PRE	Whole body PRE
25	126.60 $\pm$ 21.11	33.63 $\pm$ 9.43	30.39 $\pm$ 4.74	16.71 $\pm$ 1.19	5.43 $\pm$ 0.09	1.42 $\pm$ 0.19	43.28 $\pm$ 8.01	1.34 $\pm$ 0.10	3.13 $\pm$ 0.59	1.92 $\pm$ 0.49	2.08 $\pm$ 0.66	3.42 $\pm$ 0.49
29	132.19 $\pm$ 22.12	32.97 $\pm$ 6.40	32.14 $\pm$ 4.63	17.9 $\pm$ 1.03	5.51 $\pm$ 0.12	0.26 $\pm$ 0.05	53.12 $\pm$ 10.38	1.60 $\pm$ 0.17	3.88 $\pm$ 0.80	2.33 $\pm$ 0.68	2.08 $\pm$ 0.97	3.58 $\pm$ 0.74
34	127.96 $\pm$ 20.26	35.64 $\pm$ 9.18	33.66 $\pm$ 4.67	18.23 $\pm$ 0.45	6.34 $\pm$ 0.11	0.75 $\pm$ 0.08	49.72 $\pm$ 9.83	1.47 $\pm$ 0.19	4.21 $\pm$ 0.75	2.08 $\pm$ 1.07	2.83 $\pm$ 1.25	4.42 $\pm$ 1.39
37	134.57 $\pm$ 15.70	33.91 $\pm$ 7.13	34.97 $\pm$ 3.22	17.73 $\pm$ 0.62	6.93 $\pm$ 0.06	2.03 $\pm$ 0.47	62.97 $\pm$ 13.34	1.69 $\pm$ 0.21	5.00 $\pm$ 0.96	3.00 $\pm$ 0.84	3.25 $\pm$ 0.69	5.08 $\pm$ 1.16
39	138.94 $\pm$ 17.83	38.26 $\pm$ 9.15	38.63 $\pm$ 6.99	19.89 $\pm$ 1.91	7.34 $\pm$ 0.14	3.52 $\pm$ 2.75	63.70 $\pm$ 14.57	1.73 $\pm$ 0.17	5.13 $\pm$ 1.01	3.23 $\pm$ 0.89	3.45 $\pm$ 0.93	5.18 $\pm$ 1.38



**Fig. 3.2** Physiological responses under different-load conditions during 30-min treadmill walking (Mean  $\pm$  SD)



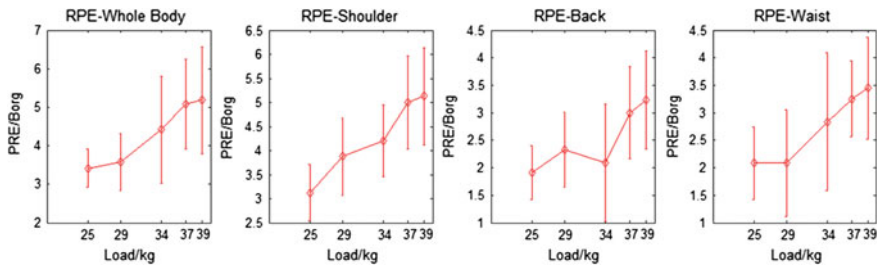
**Fig. 3.3** Biomechanical responses under different-load conditions during 30-minute treadmill walking (Mean  $\pm$  SD) (\* indicates significant difference with 25 kg, # indicates significant difference with 29 kg, + indicates significant difference with 34 kg, \$ indicates significant difference with 37 kg)

### 3.3.2 Biomechanical Signals

Figure 3.3 depicts the developing trends of shoulder force, should pressure, back pressure, and waist pressure during different-load conditions. Shoulder force gradually increased from 25 to 39-kg tests and having significant differences between them excepting for 25- and 39-kg tests. Shoulder and waist pressures went up as a whole, but came down in 34-kg test. Back pressure presented uptrend in 29–39 kg tests, but it became abnormal bigger in 25 kg than 29- and 34-kg tests.

### 3.3.3 Perceived Fatigue

Figure 3.4 depicts the developing trends of perceived fatigues in shoulder, back, and waist regions and whole body during different-load conditions. Perceived fatigues both in local regions and whole body obviously became intense along with increase of loads. Perceived fatigues in shoulder region and whole body are higher than those in back and waist regions, and it was most obvious in 37- and 39-kg tests.



**Fig. 3.4** Perceived fatigues in local regions and whole body under different-load conditions during 30-min treadmill walking (Mean  $\pm$  SD)

### 3.4 Discussions

Figure 3.2 showed that HR, VE, and VO<sub>2</sub> increased along with increase of loads. From physiological aspects, physiological stress increased must lead to enhancement of metabolic and cardiopulmonary function to fit the requirement of body. A common feature in Fig. 3.2 was the four parameters in 37- and 39-kg tests increased with significant quicker speed, which indicated that in higher loads, human body entered a new stress period and explored potential of the body to adapt to new change [11]. The mean and maximal HR in 37- and 39-kg tests were (134.6, 146.1 BPM) and (138.9, 157.4 BPM), respectively. Tanaka et al. reported that following equation could be used to predict maximal HR (HR<sub>max</sub>):  $HR_{max} = 208 - (0.7 \times \text{age})$  [12]. Based on mean age of our participants (24.7 years old), the expected HR<sub>max</sub> would be 190 BPM. From the data in Fig. 3.3, it can be calculated that participants were exercising at 70.8 % (37 kg) and 73.1 % (39 kg) of HR<sub>max</sub>, respectively. Kenney et al. reported that about 70 % of HR<sub>max</sub> could be accepted for most healthy individuals. Based on above, the participants could take exercises without influence of cardiopulmonary functions in 25–34-kg tests. But the body would work in overload status in 37- and 39-kg tests. So, the coordinate ability of cardiopulmonary would have significant influence on body fatigue. The coordinate ability could be expressed with VO<sub>2max</sub> or measuring HR<sub>max</sub> (HRM<sub>max</sub>) of individual. Bigger VO<sub>2max</sub> or HRM<sub>max</sub> indicated better coordinate ability, especially for those endurance exercises, such as long duration and continuous marching for soldiers. Consequently, for those walking on foot with higher load ( $\geq 37$  kg), VO<sub>2max</sub> or HRM<sub>max</sub> should be applied to build load carriage fatigue model. In practical application, body mass index (BMI) could be a good substitute in case VO<sub>2max</sub> and HRM<sub>max</sub> hard to get.

Figure 3.3 showed the developing trends of biomechanical signals during 30-min treadmill walking experiments under different loads conditions. Shoulder force had significant differences between different loads and had strong correlation with loads. So, shoulder force could be used as an important variable for building load carriage fatigue model. Shoulder pressure had steady increasing tendency along with increase of loads and had good correlation with loads. Therefore,



shoulder pressure was considered as good index for fatigue evaluating model. Back and waist pressure had no uniform changing tendencies and had poor correlation with loads, which resulted that pressure sensors in waist and back regions could only detect partial pressures. Body swaying and adjusting shoulder straps of backpack would make the sensor move from its original position that leads to pressure detecting error. So, some reinforcing methods should be applied to ensure that waist and back sensors would always stay on right positions.

Figure 3.4 showed that perceived fatigue in shoulder region was much higher than back and waist regions. It proved that shoulder regions played the most important role in determining load carriage limit and will be most vulnerable region of feeling fatigue or pain. These results are similar to other studies [13, 14].

### 3.5 Conclusion

Six subjects have been tested under five-load conditions during 30-min continuous treadmill walking. The result proved that 37-kg load was the turning point of human cardiopulmonary function starting working overload. The coordinate ability of cardiopulmonary system should be considered when studying treadmill walking with loads greater than 37 kg. VO<sub>2</sub>max, HRmax, or BMI could be used as covariates representing individual differences. According to the results of biomechanical analysis, shoulder force and shoulder pressure were strongly correlated with loads, which can be used as main factors for fatigue evaluation. This study analyzed relative factors leading to load carriage fatigues by physiological and biomechanical methods and laid foundation for further study on evaluating model for load carriage fatigue.

### References

1. Knapik JJ, Reynolds KL, Harman E (2004) Soldier load carriage: historical, physiological, biomechanical, and medical aspects. *Mil Med* 169(1):45–56
2. Roy TC, Knapik JJ, Ritland BM, Murphy N, Sharp MA (2012) Risk factors for musculoskeletal injuries for soldiers deployed to Afghanistan. *Aviat Space Environ Med* 83(11):1060–1066
3. Park H, Branson D, Petrova A, Peksoz S, Jacobson B, Warren A, Goad C, Kamenidis P (2013) Impact of ballistic body armour and load carriage on walking patterns and perceived comfort. *Ergonomics* 56(7):1167–1179
4. Simpson KM, Munro BJ, Steele JR (2012) Effects of prolonged load carriage on ground reaction forces, lower limb kinematics and spatio-temporal parameters in female recreational hikers. *Ergonomics* 55(3):316–326
5. Coalition Task Force 82, Coalition Joint Task Force 180 (2010) The modern warrior's combat load: dismounted operations in Afghanistan. CreateSpace Independent Publishing Platform, Seattle

6. Deepti M, Madhu SP, Dhurjati M (2010) Effects of military load carriage on kinematics of gait. *Ergonomics* 53(6):728–791
7. Grenier JG, Millet GY, Peyrot N, Samozino P, Oullion R, Messonnier L, Morin JB (2012) Effects of extreme-duration heavy load carriage on neuromuscular function and locomotion: a military-based study. *PLoS ONE* 7(8):e43586
8. Zhang WC, Shao YX, Tian Y, Chen MQ (1991) Physiological evaluation of three kinds of individual load-carrying equipments. *Chin J Ind Hyg Occup Dis* 9(5):257–262
9. Chen YH, Hao JQ (2008) Study on optimum load carriage for soldiers under different marching speed. *Chin J Ind Hyg Occup Dis* 26(12):743–744
10. Sun XJ, Tian F, Gao WY (2004) Ergonomic study on trunk lean angle and structure of backpack. *Chin J Ergon* 10(3):29–30, 51
11. Tomlin DL, Wenger HA (2001) The relationship between aerobic fitness and recovery from high intensity intermittent exercise. *Sports Med* 31(1):1–11
12. Tanaka H, Monahan KD, Seals DR (2001) Age-predicted maximal heart rate revisited. *J Am Coll Cardiol* 37(1):153–156
13. Stevenson JM, Bryant JT, Reid SA et al (2004) Development and assessment of the Canadian personal load carriage system using objective biomechanical measures. *Ergonomics* 47(12):1255–1271
14. Stevenson JM, Bossi LL, Bryant JT et al (2004) A suite of objective biomechanical measurement tools for personal load carriage system assessment. *Ergonomics* 47(11):1160–1179

# Chapter 4

## Marine Nuclear Power Plant Human Error Analysis and Protective Measures

Chuan Wang, Jianguo Zhang, Hao Yu and Shenglong Dai

**Abstract** Perform statistical analysis of occurrence time, occurrence process, accident type, and accident cause of domestic and foreign nuclear submarine accidents in detail under the existing condition. On this basis, according to the marine nuclear power plant and its operation management features, combined with the marine nuclear power plant operation and management experience, summarize and analyze the inducement of human error for nuclear power operation position operators, and propose pertinent preventive measures which have an important directive meaning on reducing human error rate of nuclear power operation position operators, improving design and construction level of the marine nuclear power plant and enhancing nuclear security level of the marine nuclear power plant operation and management.

**Keywords** Marine nuclear power plant · Human error · Analysis and prevention

After American Three Mile Island and former Soviet Union Chernobyl nuclear accident, human errors have been highly paid attention to by China domestic and foreign industrial insiders. Substantial labor forces, materials, and capital have been invested into for research. Human factor engineering field has been established, as one of the four nuclear safety technologies, giving full play to its significant role in guaranteeing the nuclear safety. According to the open research results, the anomalous events and accidents, from nuclear plants caused by human errors, account for 50–85 %. While among the anomalous events and accidents caused by human error, the part caused by operators accounts for 60–80 % [1]. Under the circumstance that equipment technology reliability is improved greatly, prevention on human errors has been regarded as one of the key issues guaranteeing nuclear safety. As the direct implementing personnel of all operations of

---

C. Wang (✉) · J. Zhang · H. Yu · S. Dai  
Naval Medical Research Institute, Shanghai 200433, China  
e-mail: hg04381@163.com

C. Wang  
Naval University of Engineering, Wuhan 430033, China

nuclear power device, the personnel of nuclear power running posts are regarded as the top priority of preventing human errors.

Comparing with the nuclear plant, the ship nuclear power device has lower automation degree. Human factor accounts for higher proportion in the whole system. The human factors of operating posts are more highlighted. According to the statistics of China's ship nuclear power service conditions, all the ships once appear anomalous events and accidents caused by human errors. For example, primary circuit resin enters into reactor core after heating and disintegration, producing profound lessons [2]. Thus, developing human factor engineering research, analyzing the seducing reasons of human errors, and adopting scientific and effective preventing measures to lower human error have important meaning to improve the device using efficiency and guarantee the safety of the nuclear power device.

## **4.1 What Is Meant by Human Error?**

### ***4.1.1 Definition of Human Error***

Human error refers to the human's action in the system exceeding the system's tolerance.

### ***4.1.2 Classifications of Human Factors***

American Nuclear Regulatory Commission classifies human error events into three kinds.

Type A: human factors before accidents and man-caused potential unavailable equipment or system;

Type B: human factors stimulating the triggering events, that is, the occurrence of preliminary events from human errors or combining equipment failures;

Type C: human factors after accidents, that is, human errors occurred after systemic failure or errors during executing safety actions or actions deteriorating the fault consequence.

### ***4.1.3 Features of Human Factor***

Human factors are featured by repetitiveness, potential, irreversibility, unavoidable, and reparability.

## 4.2 Accident Overview of Domestic and Foreign Ship Nuclear Power Unit

### 4.2.1 Accident Overview of Foreign Ship Nuclear Power Unit

It is difficult to make a statistics of how many accidents occurred for foreign nuclear power device due to the confidentiality reason. The incomplete statistics shows that, since 1954, there are over 300 accidents of ship nuclear power device issued. Among them, there are over 18 nuclear power device submerging accidents, causing over 900 seamen death [3]. Most of the accidents are caused from bumping accidents, fire disaster, and nuclear power device accidents. (See Table 4.1).

However, the accident times of actually occurred power nuclear device exceed the above number excessively. It is because that some testing accidents are not included. For example, American naval strategic nuclear weapon test has failed over 120 times. According to the law of general statistics, pressurized water reactor vapor generator accidents are over 50 %. Considering the factors of confidentiality, thus, the conservative estimation shows that the occurred ship nuclear power device shall be over 500.

### 4.2.2 Accident Overview of Domestic Ship Nuclear Power Unit

The ship nuclear power device is the symbol of national safety and large country position as the strategic weapon platform. PRC has experienced the brilliant course of about half a century and obtained the progress by leaps and bounds and became an important force of implementing historical mission of Chinese at the new phase in the new century. However, we are also confronting many imperfections like absence of shipmaking industry from science and technology, capacity deficiency of authorities and troops, lag behind of training management means, rules and regulations construction, marine risks, and failed mastery of secret worries form occasional errors. These issues obstruct the officials and soldiers at all level of Chinese marine troops. They will be reflected on the improper aspects of arms device management. The discipline of accidents and risks is very deep.

**Table 4.1** Type statistics of foreign marine nuclear power plant accidents

Types of accidents	Collision	Fire	Nuclear power plant accident	Nonnuclear leak	Sink	Explosion	Others	Total
Frequency	130	54	44	23	18	14	17	300
Rate (%)	43	18	15	8	6	5	5	100

### 4.3 Classified Statistic of Human Factors of Foreign Nuclear Power System

#### 4.3.1 Human Factor Events Before and After Accidents

Statistics conditions of human factors before and after accidents as shown by Table 4.2.

#### 4.3.2 Human Factor Stimulating the Starting Events

The statistics conditions of human factors stimulating the starting events is shown as Table 4.3.

#### 4.3.3 Human Factor Events Before and After Accidents

The statistics conditions of human factor events are shown in Table 4.4.

## 4.4 Human Factor Analysis of Ship Nuclear Power Device

### 4.4.1 Reasons of Human Factor Events

The inducing reasons of human factor events mainly include psychological factors, physiological factors, personnel educational training factors, environmental factors, task factors, running rule factors, communication factors, working factors, organization monitoring factors and systemic design, etc. Any system is composed of human, machine or human-machine interaction. The above inducing reasons

**Table 4.2** Statistics of human factor events which happened before accident occurrence

Country	Submarine name	Accident time	Causes and consequences of the accident
Russia	K-162	1980.12	Equipment during maintenance phase control rod coil reversed, leading to real boats mistakenly mentioned rod during operation
	K-431	1985.12	A loop construction defect exists somewhere in the system
	K-429	1983.6	Forgot dive due to ventilation ducts closed so that the influx of seawater compartments

**Table 4.3** Statistics of human factor events which inspired accidents

Country	Submarine name	Accident time	Causes and consequences of the accident
United States	Hull number 665	1969.5	In the process of mooring outfitting shipyard personnel do not comply with minimum security technical rules, the occurrence of an accident resulting in the sinking water
Russia	K-116	1979.7	Operator error off the main circulation pump, causing loss of coolant accident to occur
	K-431	1985.12	Operator violated technical specifications; erroneous operation caused prompt critical, explosion, and fire that sank
	Unknown	1997.5	For berth in collision with other vessels that sank

**Table 4.4** Statistics of human factor events which happened after accident occurrence

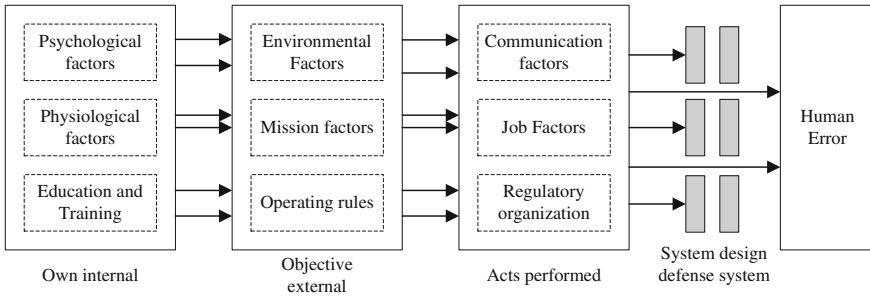
Country	Submarine name	Accident time	Causes and consequences of the accident
Russia	K-192	1989.6	The main circuit of a component leaks, artificially cut off when plugging water and not restored, resulting in loss of coolant accident
	K-116	1979.7	Operator error off the main circulating pump, the error is not corrected in time resulting in loss of coolant accident

shall be classified as its own internal reasons, objective external reasons, execution process, and preventing system. The schematic model formed by human error of the human is shown in Fig. 4.1.

## 4.4.2 Reasons of Human Factor Events

### 4.4.2.1 Degraded Working and Living Environment

In the external environment, the ship nuclear power device is mobile. They usually cruise on the ocean when reactor capability is running. Most of them are under the water. The personnel do not have the external moving space. The nuclear plant is fixed; the personnel external activity space is not limited. In terms of internal environment, due to the limited volume of ship nuclear power device hull and cabin, the working and living space is narrow and compressed, with the threat of strong noise, excessive radiation, and high temperature. The working and living environment of nuclear power plant is capacious and comfortable. The working personnel on the post nuclear power device is located under the bad environment for a long time tends to be psychological and physiological fatigue.



**Fig. 4.1** Human error causes schematic diagram

#### 4.4.2.2 Shouldering High Psychological Stress

On the one hand, ship nuclear power device shoulder the military tasks, requiring the personnel on the ship with high degree of responsibility and sense of mission. Psychological pressure is increased potentially. On the other hand, the power failure, steam overflow, smoke, and gas in the case failure lowers the visibility of cabin and quick boosting of temperature, produces scared sentiment in personnel, and seduces C type of human errors.

#### 4.4.2.3 Easily Producing Physiological Fatigue

Limited by the inside ship space and personnel load amount, the personnel on duty in turns of nuclear power running post are less than that of nuclear plant. Thus, the working intensity is massive. Meanwhile, the on-duty post in turn makes the on-duty time unfixed, disturbs the fixed biological internal clock inherently, and easily produces functional disorders. Long-time continual like this would cause the deterioration of health, lowering of working desire, and degradation of attention and inferential capability.

#### 4.4.2.4 Large Task of Difficulties, Frequency, and Complex Post Operation

Comparing with long-term stable working conditions of nuclear power plant, the ship nuclear power device requires frequent starting, stopping, and changing working conditions running considering the requirement of maneuverability. The execution task is different each time, and the difficulties to finish the tasks are heavy. Meanwhile, the automation degree of ship nuclear power device is relatively low; manual operation is frequently complex; human professional quality demand is harsh.



#### **4.4.2.5 Imbalance Between Supply and Demand of Educational Training**

Running post personnel of nuclear power requires high professional level and practice ability. It requires long-term systemic professional training and education and long-term talent growth period. Due to the limited service, each year most of people are confronting the issue of leaving or transferring. It conflicts with the personnel training period. The brain drain of post qualified personnel is higher than nuclear plant.

#### **4.4.2.6 Limited Fixed Shielding Capacity of Systemic Design**

In the human-machine system, not all the human's error action would cause the occurrence of human errors. Equipment has some fixed error tolerance and shielding capability. Operated cabin section of ship nuclear power device has limited space. Its related system, especially the safety-level system comparing with the land nuclear facilities, cannot reach the multiplicity, diversity, and redundancy design of the same level [4]. The error tolerance and distribution capacity of system is restricted to some extent, which shall be intensified in the large water surface nuclear power ship and warship design.

### **4.5 Preventing Measures of Human Factor Events**

Human factors have the objective law with unavoidable generality of human, machine, and human-environment. However, the human error factors may be lowered by mastering the human error mechanisms and formulating scientific and effective preventing measures. The specific preventing measures are as follows.

#### ***4.5.1 Developing and Carrying Out the Effective Human Error Tools***

Presently, the nuclear power running post of ship nuclear power device has not been established with a set of preventing measures of human errors. The common quick and efficient work way of promoting this work is to learn and borrow the advanced experience of the existing nuclear power plants, so as to realize "introduction, assimilation, and absorption." For example, most nuclear power plants like Tianwan Nuclear Plant, Qinshan Nuclear Power Plant, and Dyawan Nuclear Power Plant have finished the development of human error tools and publicized for application. They realize remarkable efficiency in lowering human error ratio. Learning from and borrowing the previous results and experience can

avoid detours. Ship nuclear power device running post personnel have many differences with nuclear power plants due to the features. We should pay attention to master their own features and law and improve the suitability and pertinence. Meanwhile, intensify the implementation of the terminals. Human error tools are formulated against personnel. The efficiency can be given full play only implementing on each post. Therefore, it is feasible to imitate how nuclear power plants act, to make human error tools prevention as brochure and portable cards or tangible carrier to bring with each person, beneficial to learning and application.

#### ***4.5.2 Pay Attention to Advocating the Training of Nuclear Safety Culture***

Human error prevention belongs to not only the nuclear safety technology category, but also the nuclear safety culture category. It is an important measure to improve the nuclear safety and cultural level. By advocating training nuclear safety culture, improving personnel overall quality, increasing the nuclear safety consciousness of applying and learning laws, and forming safety shield and last shield of each person, the whole human error preventing work will be improved substantially.

#### ***4.5.3 Perfect and Strictly Abide by the Running Specification and Prearranged Scheme***

Due to the requirement of maneuverability, ship nuclear power device requires frequent starting, shutting down, and working conditions changing. Reactor running transients are numerous, and it is very difficult for operators to operate. Therefore, perfect running specification and prearranged scheme is the basis of running safety. Due to the complex working conditions, the running specification and prearranged scheme are difficult to cover all the conditions, requiring progressive improvement. Due to the complex and difficult operational working conditions, the operators shall abide by the running specifications and prearranged scheme closely.

#### ***4.5.4 Establish Experience Feedback Mechanism and Improve the Responding Capacity Under the Extreme Conditions***

According to the running experience of the past years, some extreme conditions exceeding the running specifications and pre-arranged scheme. In particular, under the circumstance of accidents, the time effectively processing accidents is calculated as per a second. The running personnel shall be able to make quick judgment

and adopt effective solutions to make up the insufficiency of running specification and prearranged scheme. They shall not only excel in professional practice, but also have abundant practical experience. Therefore, it is very necessary to establish a set of experience feedback system to fill in the status reporting record about the appeared abnormal events and make the analysis and summary, so as to reach the error correcting actions, continually improve the work, and accumulate the experience.

#### ***4.5.5 Establishing the Systemic Educational Training Mechanism***

The educational training of ship nuclear power device running posts has formed comparatively perfect system. The prevention of human errors shall also require that (1) the issue of growth-up term of running post personnel and server period limitation shall be solved; running post personnel are confronting the issue of staying or leaving each year; the working personnel may fluctuate in the thought; thus, educational persuasion shall be intensified; favorable policies may be formulated to keep stability of the staff; (2) pay priority to the psychological and physical intensifying training; lay stress on psychological counseling and drill, intensify exercise, and keep good physical and mental status; (3) develop human error training of special themes; currently, nuclear power plants have started the human error specialized theme training and formulated the Training Syllabus of Human Error Against Errors course. The effective practice is worthy of borrowing.

#### ***4.5.6 Improve the Systemic Equipment Design and Advance the Shielding and Error-Tolerating Capacity***

While improving the reliability of humans, the overall design of systemic equipment shall lay stress on human error engineers, improve the living and working environment, advance human-machine interface to make the interface more friendly, beneficial to human-machine interaction, try to increase the diversity and redundancy of safety-level system equipment, and improve the shielding and error-tolerating capacity. It is also the important link of lowering human errors [5].

### **4.6 Conclusion**

This paper is based on the numerous human factors of ship nuclear power device, combining the running management experience of ship nuclear power device according to the ship power device and feature of running management and

making a summary and analysis on the reasons of human errors of ship nuclear power device running posts. This paper puts forth corresponding preventing measures against the human errors, which have important guiding significance to lower the human error rate of ship nuclear power device by running post personnel and boost the nuclear safety level of nuclear power device running management.

## References

1. Yang M (2002) Development of human factor engineering. *China Eng Sci* 4(8):14
2. Yu L (2012) Nuclear security basic problems and prevention of nuclear submarine. Navy University of Engineering Press, Wuhan, pp 56–57
3. Yang L (2007) Get into nuclear submarine. Navy Press, Beijing, pp 169–170
4. Zhu J (2004) Get into nuclear submarine. Xi'an Jiao Tong University Press, Xi'an, pp 7–9
5. Mao C (2012) Discussing the design of digitized I&C for NPP from the perspective of safety review development of human factor engineering. *Autom Instrum* 33(7):39–40

# Chapter 5

## The Development of Professional Morality Questionnaire for Civil Pilots

Yuchuan Luo, Xiaoli Luo, Quanchuan Wang and Xianlin Zeng

**Abstract** *Objective* To develop a questionnaire of civil pilots professional morality. *Methods* The theory structure of professional morality of civil pilots was constructed. Regarded to the theory structure and the result of documents and specialists evaluation, a questionnaire of civil pilots professional morality was developed. In order to examine the validity, 324 pilots of CAAC were tested. *Results* The professional morality of civil pilot was composed of three key dimensions. The Cronbach of full questionnaire was  $\alpha = 0.863$ , and the content validities were from 0.760 to 0.842 ( $P < 0.01$ ). Coefficient of stability of the questionnaire was beyond 0.463 ( $P < 0.01$ ), and criterion validity of questionnaire was 0.564 ( $P < 0.01$ ). Confirmatory factor analysis (CFA) of questionnaire met the requirements. *Conclusion* The questionnaire proves to be applicable to civil pilots in evaluating their professional morality.

**Keywords** Civil pilot · Professional morality · Questionnaire

### 5.1 Introduction

Professional morality means the total sum related to the occupational activity with the moral code and norms of occupational features. It is the materialization of general social ethnical principle and norms in the occupational life and the important supplement [1] of the general social ethnical principles and norms. The professional morality status quo of civil pilots will be directly affect their working performance and behaviors and manifest on the safety and benefit of aviation.

---

Y. Luo (✉) · X. Luo · Q. Wang · X. Zeng  
Aviation Human Factors and Ergonomics Lab, Civil Aviation Flight University of China,  
Guanghan 618307, Sichuan, China  
e-mail: reven-lyc@163.com

X. Luo  
e-mail: crmluo@aliyun.com

The China domestic scholars have started their study on the job regulation [2], stress [3] and personality of civil pilots [4], but quantitative research has not yet involved in professional morality of the civil pilots. This research aimed to develop research on the professional morality of civil pilots and formulated a questionnaire of civil pilots professional morality.

## 5.2 Methods

### 5.2.1 Dimensions and Items

After consulting the related literary involved in professional morality of civil pilots [5, 6], carrying out interview with the civil pilots, ground instructors, political and trade union cadres, and family members of civil pilots from China Eastern Airlines, Shanghai Airline, China Cargo Airlines, Northwest of China Eastern Airlines Corporation Limited, Yunnan Airlines of China Eastern Airlines Corporation Limited, combining the opinions of aviation psychology experts, reflect the social responsibility, fundamental interest and career development of the civil pilots according to professional morality, this paper proposes the operational definition of professional morality of the civil pilots as the behavior performance standard of faithfully implementing rules and regulations, standards, manuals and reducing the human errors, and realizing the safety aviation.

On this basis, this paper proposes four dimensions of civil pilots' professional morality including responsibility, preciseness, safety concept, and regulatory concept. After implementing three rounds of Delphi letter consulting method and analytic hierarchy process (AHP) on the pilots of some domestic aviation airlines and experts from Shanxi Normal University, Civil Aviation Flight University of China and Mianyang Normal College, this paper confirms three dimensions of civil pilots' professional morality responsibility, safety concept, and regulatory concept.

By collecting data and combining the operational definitions and above-mentioned interview results, the writers formulated the original items of questionnaires and invited aviation psychological experts to discuss items one by one, deleted the items with ambiguity or inconformity with questionnaire testing purpose, and finally formed preliminary testing version of *Questionnaire of Civil pilots Professional Morality*. Questionnaire was recorded with 5-point Likert Scale, successively as "completely non-conformity, basically non-conformity, unconfirmed, basically conformity, and completely conformity," respectively, giving 1–5 points of assessment.

### **5.2.2 Subjects**

The stratified random sampling method is adopted in all sub-airlines of all aviation airlines. Four hundred and sixty-five civil pilots are selected for testing. After getting rid of the questionnaire of set effect, social desirable behavior, and false answering, 324 questionnaires are obtained and the effective ratio reaches 69.7 %.

According to the age distribution conditions, the civil pilots above 50 years old account for 5.38 %; the civil pilots from 40 to 49 years of age account for 18.83 %; the civil pilots from 30 to 39 years of age account for 30.80 %; the civil pilots below 29 years of age account for 44.99 %; captain and captain instructors account for 41.57 %; copilots and pilots account for 49.87 %; and flying cadets account for 8.56 %.

### **5.2.3 Statistics Tools**

Adopt SPSS18.0 and AMOS7.0 to make statistic analysis on data.

## **5.3 Results**

### **5.3.1 Exploratory Factor Analysis Results**

Investigation acquires 324 answers. Adopt principal component analysis (PCA) to make exploratory factor analysis extract common factor. The test value of Kaiser–Meyer–Okun measure of sampling adequacy (KMO) is 0.899. Bartlett test value is 1839.945 ( $P < 0.001$ ), which demonstrates that the data are suitable for exploratory factor analysis. The number of factors shall be confirmed by the following standards. The factor feature value exceeds 1; factor solution must meet screen test; the factors withdrawn can explain 3 % of the total variation at least before rotating; each factor includes over three items at least; items only rise contribution rate to some factor; and the contribution rate to other factors does not exceed 0.30. The 15 items finally acquired, meeting the requirement form Questionnaire of Civil pilots Professional Morality.

It can be seen from Table 5.1 that three factors explain 58.236 % of the total variance. All items corresponding to factor load are located among 0.624–0.785. Dimension 1 contains five items, involving whether civil pilots can abide by the related rules, regulations, and disciplines, named as “regulatory concept”; dimension 2 contains five items, involving whether civil pilots can be responsible clearly and bear the responsibility, thus called as “responsibility”; dimension 3 contains five items, involving whether civil pilots attention flight safety, thus called as “safety concept.”

**Table 5.1** Results of exploratory factor analysis ( $n = 324$ )

Factors	Regulatory concept		Responsibility		Safety concept	
	Item	Comp	Item	Comp	Item	Comp
Items comp	8	0.760	33	0.785	7	0.751
	16	0.725	30	0.763	11	0.715
	4	0.714	34	0.741	19	0.665
	13	0.668	22	0.654	27	0.642
	12	0.643	29	0.648	38	0.624
Eigenvalue	5.662		1.922		1.151	
Percentage of variance (58.236 %)	37.748		12.814		7.674	

### 5.3.2 Analysis of Reliability

Adopt internal consistency coefficient and stability coefficient to inspect the reliability of questionnaire. Randomly select 40 civil pilots with valid answers and implement remeasurement 30 days later to check the test–retest reliability of questionnaire, with the specific contents as Table 5.2.

Table 5.2 shows that the Cronbach coefficient of all dimensions and overall part ranges from 0.753 to 0.863, reaching the acceptability standard. It demonstrates that all dimensions of questionnaire have good internal consistency. The retesting correlation coefficient of all dimensions and total points of questionnaire range from 0.463 to 0.671 ( $P < 0.01$ ). It demonstrates that questionnaire has good test–retest reliability.

### 5.3.3 Analysis of Validity

Adopt leaders peer assessment to test the validity of questionnaire of civil pilots professional morality; ask for the authority leaders of 31 tested civil pilots to make 1–5 grade assessment of the professional morality; make the significance testing of the coefficient of association on the score of the testes; the results ( $r = 0.564$ ,  $P < 0.01$ ) show that the coefficient of association between the two aspects is high and reaches the significance level. It demonstrates that the questionnaire has higher criterion validity.

**Table 5.2** Reliability test

Factors	Cronbacha ( $n = 324$ )	Retest reliability( $n = 40$ )
Regulatory concept	0.827	0.577**
Responsibility	0.825	0.463**
Safety concept	0.753	0.595**
Total	0.863	0.671**

Note \*\*  $P < 0.01$ ,  $P < 0.05$

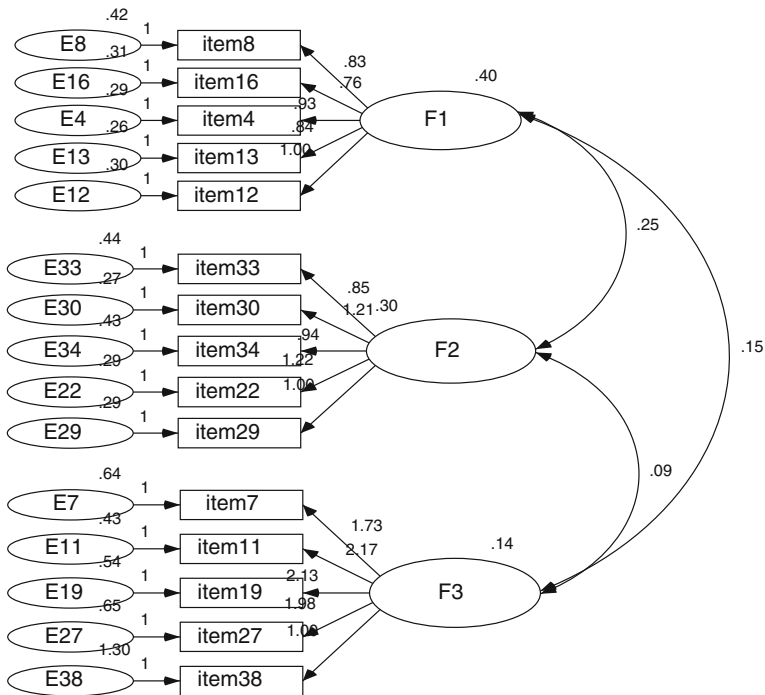


**Table 5.3** Result of content validity ( $n = 324$ )

	Regulatory concept	Responsibility	Safety concept	Total
Regulatory concept	1.000			
Responsibility	0.575**	1.000		
Safety concept	0.486**	0.302**	1.000	
Total	0.842**	0.760**	0.786**	1.000

According to the theory of Tucker [7], the required dimensions and tests constituting perfect project fall from 0.3 to 0.8 in correlation; the correlation among dimensions falls from 0.10 to 0.60. As shown in Table 5.3, the correlation coefficient among dimensions of questionnaire ranges from 0.302 to 0.575; the correlation between dimensions and overall scores ranges from 0.760 to 0.842. It demonstrates the better structure validity of questionnaire.

Adopt AMOS7.0 to make confirmatory factor analysis (CFA) on data ( $n = 324$ ). The results refer to Fig. 5.1 and fit index refers to Table 5.4.



**Fig. 5.1** Confirmatory factor analysis of three-factor model

**Table 5.4** Result of confirmatory factor analysis ( $n = 324$ )

	X2	df	X2/df	GFI	CFI	IFI	NFI	RMSEA
Default model	165.957	87	1.908	0.935	0.955	0.956	0.911	0.053

Figure 5.1 and Table 5.4 show that the CFA results of factor model and all fit index reach the requirement, which claims the good fit between the model and data [8].

## 5.4 Discussion

In terms of the features of professional morality, professional morality reflects the special requirement of the occupation on practitioners, with definite pertinency and long-term stability [9]. Safety is the maximal requirement of civil pilots' occupation; thus, civil pilots shall bear in mind that safety is the foremost aspect. Meanwhile, they shall hold definite attitude to the responsibility. Closely abiding by the flying procedures, rules and regulations and standard operating procedures are the effective way to prevent misuse, mistake, forgetting, and negligence [10]. Thus, the three dimensions, regulatory concept, safety concept, and responsibility, obtained from three rounds of Delphi letter inquiry method and AHP, annotate the contents of the professional morality of civil pilots.

Exploratory factor analysis (EFA) and CFA demonstrate the rationality of the theoretical supposition model of civil pilots' professional morality. EFA abstracts three dimensions, regulatory concept, safety concept, and responsibility; CFA indicates that structural model and data can fit preferably. It demonstrates that the structural model of questionnaire of civil pilots professional morality meet the standard of surveying.

In the aspect of reliability and validity, Cronbacha coefficient of the three dimensions reaches above 0.753; the  $\alpha$ -coefficient of the questionnaire is 0.863; according to the correlation analysis of resurveyed data, the correlation of all items reaches above 0.463 ( $P < 0.01$ ). The criterion validity adopts the method of leading peer assessment checking the related coefficient, with the correlation coefficient of  $r = 0.564$  ( $P < 0.01$ ); dimensions of questionnaires have the correlation of medium level to lower level. All dimensions have higher correlation to the overall aspect. It demonstrates that questionnaire have good structural validity.

## 5.5 Conclusion

Questionnaire of civil pilots' professional morality has good reliability and validity, which can be taken as the measuring and assessing tools of civil pilots' professional morality research. Through the specific assessment and testing, the

civil pilots' status of professional morality can be quantified, providing data support for policy makers of the Civil Aviation Administration and Airlines, so as to improve the working status and quality of civil pilots and realize the guarantee of flying safety at finally.

## References

1. Xu S-J, Wen K-Q (1999) Ethics encyclopedia. China Radio & Television Publishing House, Beijing
2. Luo Y-C, Mou H-Y, Deng X-M (2001) Study on job-regulation of civil aviation pilots. *China Saf Sci J* 21(1):17-21
3. Zhao X, Xu B-H, Gao X (2010) Research on development of "psychological stress questionnaire of china civil aviation pilots". *Space Med Med Eng* 23(1):35-41
4. Gao Y, Chen W, Sun R-S (2010) Research on personality traits and influential factors of civil aviation pilots in china. *J Saf Sci Technol* 6(6):30-34
5. Wang Q-C (2012) Eight safety consciousnesses of professional pilot. *Saf Secur* 9(141):51-54
6. Liu Q-G (2011) Pilot qualifications must  $\geq$  position requirements. *Saf Secur* 11(131):40-43
7. Dai Z-H (1987) Psychology educational measurement. East China Normal University Press, Shanghai
8. Rong T-S (2009) AMOS and research method. Chongqing University Press, Chongqing
9. Chen S (1997) On profession and professional morality. *J China Youth Univ Polit Sci* 2:59-64
10. Luo Y, Chen J, Yang J et al (2013) Research on the relationship between threat and crew error in civil aviation. In: Long S, Dhillon BS (eds) Proceedings of the 13th international conference on man-machine-environment system engineering. Lecture notes in electrical engineering. Springer, Berlin, Heidelberg, pp 365-370

# Chapter 6

## Study on Function of Neurotransmitters and Brain of Chronic Brain fog Sufferers

Yaofeng He, Guansheng Huang, Haiyan Niu, Yuping Luo,  
Yajuan Bai and Jianlan Xu

**Abstract** *Objective* To study the function of neurotransmitters and brain and to explore the mechanism of chronic brain fatigue. *Methods* fatigue group: 200 chronic brain fog sufferers, control group: 120 common people; compare the power and relative power of nerve, index of cerebral function by EFG. *Results* (1) All nerve power of fatigue group are significantly lower than the control group ( $P < 0.01$ ); (2) the relative power of GABA, Glu, and NE of fatigue group are significantly lower than the control group ( $P < 0.05$ ), there are no significant difference in other relative power between two groups; (3) fatigue group's total power and index of blood vessel systolic or diastolic are significantly lower than the control group ( $P < 0.01$ ), the exercise index is also significantly lower than the control group ( $P < 0.05$ ), but the entropy is significantly higher than the control group ( $P < 0.01$ ). *Conclusion* There are significant differences in power of all neurotransmitters, parts of relative power, and index of brain function between the two groups, which suggests that change of these indices may be the cause of chronic brain fog.

**Keywords** Chronic brain fog · Encephalofluctuograph · Neurotransmitter · Index of cerebral function

### 6.1 Introduction

Fatigue means failure of concentration and efficiency keeping during the working process [1]. Fatigue is a major actual issue. The research of fatigue has important significance in the movement, labor safety, and military affairs. How to delay the fatigue and how to remove fatigue and the unbeneficial aftermath are the issues to be solved in the actual social life.

---

Y. He (✉) · G. Huang · H. Niu · Y. Luo · Y. Bai  
Beijing Special Vehicle Institute, Beijing 100072, China  
e-mail: lei\_he2010@126.com

J. Xu  
Beijing Shu-Pu-Sheng Company, Beijing 100730, China

According to the occurrence position, fatigue can be divided as peripheral fatigue and central fatigue [2]. Peripheral fatigue mainly refers to muscle fatigue, whereas central fatigue mainly refers to brain fatigue. Brain fatigue mainly indicates as deficiency of motivation and alertness, laziness, sleeping status, dizziness, and inattention. If peripheral fatigue and brain fatigue cannot be effectively intervened and corrected, generally it grows as chronic fatigue syndrome.

Apart from muscle fatigue, there are no objective quantitative checking ways for brain fatigue. Although there are assessing standards of subjective fatigue [3, 4], so far the decisive means or quantitative standards of subjective syndromes or objective deciding means are not mastered. The difficulties of brain fatigue lies that the present technical means cannot directly check the intracerebral conditions directly in the absence of cut.

EFG analyzer can quantitatively check the intracerebral nerve delivery quality [5, 6] in the absence of cut. It can be taken as the detecting means of brain fatigue. This test uses EFG analyzer to research the neurotransmitter function and brain function of chronic fatigue sufferers, with a view to exploring the occurrence mechanisms of chronic brain fatigue.

## 6.2 Objects and Methods

### 6.2.1 Objects

Fatigue group: 200 examples of chronic brain fatigue as government functionaries; 119 male examples, 91 female examples; 25–66 years old, average ( $38.9 \pm 12.3$ ) years old; Selection standard: sustaining the clinic syndromes of lack of power, hypomnesia, inattention, insomnia, headache, and fatigue sense for over 6 months.

Contrast group: 120 normal cases, 68 male cases, 52 female cases; 20–65 years' old, average ( $33.6 \pm 10.5$ ) years old, healthy, no nerve systemic illnesses and psychiatric history; no positive syndromes in nerve system checkup, without taking medicine on nerve system 7 days before checkup.

Exclusion criteria: (1) confirming the diagnostic body illnesses; (2) confirming the diagnostic mental disease; (3) acute infection, trauma, and operation history within two weeks; (4) Taking medicine affecting the central nervous system within a week.

### 6.2.2 Methods

EFG checking method: The testees keep sitting and eye-closed resting status during the check. Arrange electrodes as per the systemic method of 10–20 lead stem of the international stands. There are 16 electrodes arranged (F1, F2, F3, F4,

C3, C4, P3, P4, O1, O2, F7, F8, T3, T4, T5, and T6). Reference electrode is placed at the earlobes. Respectively collect the electroencephalogram (EEG). After collecting the signals, encephalofluctograph (EFG) (Developed by Beijing Shu-pusheng Company) automatically makes an analysis of EFG on signals. Make analysis and comparison of the neurotransmitter power, relative power, and brain functional index.

### 6.2.3 Processing of Statistics

Adopt SPSS 17.0 statistics software to process data. The results are expressed by average value  $\pm$  standard deviation ( $\chi \pm s$ ). The difference between fatigue group and contrast group is tested by independent sample t test. The significant difference shall be  $P < 0.05$ . The extreme significant difference shall be  $P < 0.01$ .

## 6.3 Results

Contrast and analysis results of between fatigue group and contrast group refer to Tables 6.1, 6.2, and 6.3.

Tables 6.1, 6.2, and 6.3 shows all the neurotransmitter power level of fatigue team is significantly lower than the contrast group ( $P < 0.01$ ); the neurotransmitter power level occupies about 20 % of the contrast group; in the relative power level of neurotransmitter, the relative power of GABA, Glu, and NE is evidently lower

**Table 6.1** Power of neurotransmitters between fatigue group and control group

Power of neurotransmitters	Fatigue group	Control group
GABA	10.82 $\pm$ 6.36	56.41 $\pm$ 48.67**
Glu	10.43 $\pm$ 8.61	51.75 $\pm$ 42.03**
EN3	100.33 $\pm$ 84.65	438.28 $\pm$ 361.64**
5-HT	78.93 $\pm$ 56.88	354.02 $\pm$ 321.01**
ACh	57.81 $\pm$ 46.34	242.93 $\pm$ 190.26**
EN6	44.80 $\pm$ 41.82	201.63 $\pm$ 156.78**
NE	37.52 $\pm$ 30.13	180.67 $\pm$ 152.69**
DA	24.67 $\pm$ 21.45	99.75 $\pm$ 68.70**
IN13	18.94 $\pm$ 16.75	85.11 $\pm$ 72.57**

\*  $P < 0.05$  indicates significance difference

\*\*  $P < 0.01$  indicates extreme significance difference

EN3 excitatory neurotransmitter 3, 5-HT 5-hydroxy tryptamine, ACh acetylcholine, DA dopamine, IN13 inhibitory neurotransmitter 13

**Table 6.2** Relative power of neurotransmitters between fatigue group and control group

Relative power of neurotransmitters	Fatigue group	Control group
GABA	23.16 ± 19.17	50.61 ± 47.17**
Glu	30.98 ± 17.93	45.92 ± 33.24*
EN3	376.02 ± 32.35	351.70 ± 43.76
5-HT	290.63 ± 35.94	276.13 ± 29.49
ACh	224.82 ± 36.91	203.01 ± 44.30
EN6	175.37 ± 21.02	169.25 ± 32.16
NE	145.29 ± 22.44	164.36 ± 32.38*
DA	96.07 ± 17.56	92.67 ± 32.88
IN13	76.81 ± 18.23	70.73 ± 18.51

\*  $P < 0.05$  indicates significance difference\*\*  $P < 0.01$  indicates extreme significance difference**Table 6.3** Index of cerebral function between fatigue group and control group

Index of cerebral function	Fatigue group	Control group
Total power	358.76 ± 217.31	1,454.33 ± 1,260.97**
Exercise index	0.454 ± 0.069	0.518 ± 0.118*
Excitatory inhibitory index	1.753 ± 1.185	1.36 ± 0.92
Vasomotion index	0.495 ± 0.091	0.587 ± 0.161**
Entropy	88.68 ± 6.94	74.25 ± 12.02**

\*  $P < 0.05$  indicates significance difference\*\*  $P < 0.01$  indicates extreme significance difference

than the contrast group ( $P < 0.05$ ); the relative power of other neurotransmitters does not have significant differences among two groups; in the terms of brain function index, total power and vasomotion index are significantly lower than the contrast group ( $P < 0.01$ ); the movement index is evidently lower than the contrast group ( $P < 0.05$ ); whereas entropy value is significantly higher than the contrast group ( $P < 0.01$ ).

## 6.4 Discussions

Chronic brain fatigue is caused by long-term irregular brain using or, under the pressure of examinations for higher school enrolling and being promoted, long-time studying, learning, or overwork to the extent that brain cannot rest timely and sufficiently. Or the reasons of living habits, economic conditions or illnesses cause

insufficient nutrition or increased consumption. They cannot provide sufficient energy and all kinds of nutrients for the activities of neurons. Thus, mental fatigue easily occurs. The occurrence of chronic fatigue requires a long-time accumulation process similar to the fatigue after long-time movement training.

Presently, the reasons and mechanism of brain fatigue have not been ascertained. As for the occurrence mechanism of brain fatigue, scientists propose many hypotheses. Among them, 5-HT hypothesis is recognized widely [7]. 5-HT hypothesis proposes that H-5T has high thickness within the brain in the case of fatigue. Literary reports that acute movement increases brain stem, the integration, and metabolism of 5-HT [8]. Long-term movement training would lower the level of 5-HT, DA, and NE [9, 10]. In other researches, the research made by Baily et al. shows that in the case of central fatigue, DA integration of mesencephalon in central fatigue would be weakened [11]. The maintaining of DA integration anabolism would retard the fatigue. Mieko [12] finds that when Ach thickness lowers in pivot, central fatigue would occur. The research by Chaouloff et al. [13, 14] shows that chronic brain fatigue is not caused by the change of single neurotransmitter, but the result of interaction between variant neurotransmitters and breakdown of balance among them. They found that DA activity increase in the brain can curb 5-HT integration and metabolism. When the ratio of 5-HT/DA in the brain rises, movement fatigue would occur. Moreover, research indicates that when body movement appears fatigue, the metabolic balance of Glu and GABA in encephalic region is changed. The balance of original quietness is damaged. GABA inhibition effect in the brain dominates [15].

This research analyzes and contrasts the neurotransmitter power, relative power, and brain power index of the chronic brain fatigue sufferers and normal persons, so as to explore the differences of all indicators level among two groups of person group and find the possible mechanism in the case of chronic brain fatigue.

Neurotransmitter power refers to the power of the produced electricity acted by neurotransmitter and acceptor. Generally, it depends on the thickness of neurotransmitter. This research finds that 9 kinds of neurotransmitter power of chronic brain sufferers are evidently lower than the normal people level ( $P < 0.01$ ). It shows that 9 kinds of neurotransmitter thickness within chronic brain fatigue sufferers are located at the lower level, which conforms to the related literary reports [9, 10].

Relative power refers to the relative size of single neurotransmitter. The relative power of GABA and Glu of chronic brain fatigue sufferers is substantially lower than the normal people's level ( $P < 0.05$ ). It shows that comparing with other neurotransmitter, the functions of GABA and Glu of sufferers are lower substantially, at the weak position. GABA and Glu are related to the advanced functions of the brain, such as learning and memory, etc. Thus, the function decline of GABA and Glu may be physiological mechanism of chronic brain fatigue sufferers learning, decline of memory capability, and inattention. Moreover, this research also finds that the relative power of NE of chronic fatigue sufferers is evidently lower than the normal people's level ( $P < 0.05$ ). It shows that the NE functions of



chronic brain fatigue sufferers decline. Apart from the adjustment of participating in movement, NE participates in adjusting mood. It is also probable that chronic brain fatigue, apart from movement ability lowering, may arise melancholy and anxiety mood emotional disorder.

In terms of brain functional index, the total power of whole brain of chronic brain fatigue sufferers in this research is evidently lower than the level of normal people ( $P < 0.01$ ). Then, entropy is higher than the normal people ( $P < 0.01$ ), indicating that the overall functions of brain of the chronic brain fatigue sufferers declines. It may probably explain the clinical syndromes of chronic brain fatigue. The movement index of chronic brain fatigue sufferers (ratio of DA and 5-HT in the brain) is evidently lower than the normal people ( $P < 0.05$ ). It indicates that the movement excitability of the chronic brain fatigue sufferers declines, which is related to the reaction ability and coordinating ability in movement, conforming to literary report [13, 14]. Moreover, this research also finds that vasomotion index of chronic brain fatigue sufferers is evidently lower than the level of the normal people ( $P < 0.01$ ). Vasomotion index is the indicator used to indicate the status of vasomotion in the brain. The higher the vasomotion index, the higher degree the vasomotion index in brain; conversely, the shrinkage degree will be higher. Therefore, the above-mentioned results show that the blood vessels of chronic brain fatigue sufferers are dominated by shrinkage, which may be reason of the brain function decline of chronic brain fatigue sufferers.

## 6.5 Conclusions

Evident differences exist between neurotransmitter power, partial relative power, and index indicators of brain functions of and chronic brain fatigue sufferers. The prompting of the above indicator change may be the reason causing chronic brain fatigue occurrence. EFG can detect the neurotransmitter and brain function within brain by noninvasive quantitative detection and can also analyze the degree of brain fatigue quantitatively. It is an effective detecting means of brain fatigue.

## References

1. Layzer RB (1998) Asthenia and the chronic fatigue syndrome. *Muscle Nerve* 21(12):1609–1611
2. Chaudhuri A, Behan PO (2000) Fatigue and basal ganglia. *Neurol Sci* 179(S122):34–42
3. Wu W, Wang Z (1990) SCL-90. *Shanghai Arch Psychiatry* 2(supplement):68–69
4. Wang T, Zhang C (2001) FS-14. *Chin J Behav Med Sci* 10(special issue):61
5. Li S, Yang M, Liu Y (2008) EEG in sub healthy people with insomnia neurotransmitters in the brain activity of the super slow encephalofluctuograph performance. *J Pract Med* 24(1):39–41

6. Chen J, Chen Q, Zhang G (2007) Encephalofluorograph detecting changes of patients with Alzheimer's disease brain neurotransmitter. *S Five Ridges J Emerg Med* 12(3):182–184
7. Davis JM, Bailey SP (1997) Possible mechanism of central nervous system fatigue during exercise. *Med Sci Sports Exerc* 29(1):45–47
8. Dey S, Singh RH, Dey PK (1992) Exercise training significance of regional alterations in serotonin metabolism of rat brain in relation to antidepressant effect of exercise. *Physiol Behav* 52(6):1095–1099
9. Dhir A, Kulkarni SK (2008) Venlafaxine reverses chronic fatigue-induced behavioral, biochemical and neurochemical alterations in mice. *Pharmacol Biochem Behav* 89(4):563–571
10. Hoffmon P (1994) Effects of long-lasting voluntary running on the cerebral levels of dopamine, serotonin and their metabolites in the spontaneously hypertensive rat. *Life-Sci* 54(3):855–861
11. Bailey S, Davis JM, Arlbom EN (1993) Neuroendocrine and substrate responses to altered brain 5-HT activity during prolonged exercise to fatigue. *J Appl Physiol* 74:3006–3012
12. Kurosawa M (1993) Extracellular release of acetylcholine noradrenaline and serotonin increases in the cerebral cortex during walking in conscious rats. *Neurosci Lett* 16:73–76
13. Lv R (2001) Research progress of neuromuscular fatigue in physiology. *Sports Sci* 22(3):34–36
14. Meeusen R, Watson P, Hasegawa H et al (2006) Central fatigue: the serotonin hypothesis and beyond. *Sports Med* 36(10):881–909
15. Li R, Tao X (1985) Sports fatigue and r- in the brain of GABA. *Chin J Sports Med* 2:81–86

# Chapter 7

## A Study on Analysis of Learners in Instructional Design

Yanyan Chen, Genhua Qi and Hong He

**Abstract** Instructional design is the advanced presentation of the thinking of the instruction. It is an important stage in instruction preparation. The instructional design should be of comprehensiveness and pertinence. Various instructional methods may be adopted in accordance with different types of learners to achieve high efficiency. The analysis of learners should be highlighted and necessary in the design. The mastery of the characteristics of the learners may facilitate the accurate determination of the instructional contents and methods. It is the basis for guarantee of instructional effect. The analysis of learners should be comprehensive. It should cover the past and the present situations. This paper makes a study on the analysis of learners in instructional design with provision of some new ideas.

**Keywords** Instructional design · Learners · Instructional process · Study

### 7.1 Introduction

The instruction is a creative and artistic activity. Whether the instructional objective is achieved or not depends to a large extent on the analysis of the learners. The analysis of learners should be scientific and comprehensive. The emphasis should be put on personality traits of the learners so as to solve a series of problems in the instructional process. This paper makes a study on the comprehensive analysis of the learners in connection with the instructional process from the view of the importance of the analysis of the learners.

---

Y. Chen (✉)

Police Management Department of Henan Police College, Zhengzhou 450000, China  
e-mail: qigenhua1023@163.com

G. Qi · H. He

Air Defense Forces Academy, Zhengzhou 450052, China

© Springer-Verlag Berlin Heidelberg 2015

S. Long and B.S. Dhillon (eds.), *Proceedings of the 14th International Conference on Man–Machine–Environment System Engineering*,

Lecture Notes in Electrical Engineering 318, DOI 10.1007/978-3-662-44067-4\_7

## **7.2 Significance of Analysis of Learners**

Instructional design is the advanced design of the instructional process and shows a teacher's class control capability. The thorough analysis of the learners may better research into the instructional contents and make instructional process more reasonable. Specifically, the analysis of the learners mainly functions as follows:

### ***7.2.1 Detail Instructional Process***

Instructional process means the process to impart the instructional contents. It is an instructional process as well as a learning one. Whether the learners study successfully or not depends on the teacher's capability and the learners' qualities. The analysis of the learners is just on purpose to get the knowledge of the learners' situation. The instructional design should highlight the points of importance and help the teacher have a good control of the class.

### ***7.2.2 Quantize Instructional Contents***

Instructional contents are the key job in class instruction. The conduction of instructional contents makes up the whole instructional process. Each period of class has its important and difficult points. Thus, teachers should quantize the instructional contents to achieve the continuity of various points of knowledge. The analysis of the learners' characteristics may facilitate quantization of the instructional contents so as to ensure the completion of instructional contents.

### ***7.2.3 Optimize Instructional Effect***

The instructional effect is the forceful criterion for the evaluation of class instruction. The learning effect of learners is the key evaluating index of instructional effect. The learners' characteristics should be put into consideration and the learners should be taught in accordance with their aptitude in terms of the learning effect. The evaluation of the instructional effect is made through examination as written examination, oral examination, paper, etc. The difference of learners should be taken into account in checking the instructional contents. The analysis of the learners can attain the goal of distribution of instructional contents according to diversified needs of the learners. The lecture may be given by the use of different methods to achieve the understanding of the contents by the learners as many as possible.

### **7.3 Necessity of Analysis of Learners**

#### ***7.3.1 Reasonable Arrangement of Instructional Contents Requires Analysis of Learners***

The instructional contents are the principal part of class instruction, so the instructional contents should be arranged reasonably. What contents should be lectured at what time and by what method should be arranged in a scientific way. There exists continuity between each parts of a subject. The learning effect of each point of knowledge should be estimated in advance; in other words, whether the learners can master the knowledge or not should be taken into account before lecture. Therefore, it is necessary to make a meticulous analysis to ensure the reasonable arrangement of the instructional contents.

#### ***7.3.2 Effective Control of Instructional Rhythm Requires Analysis of Learners***

The arrangement of instructional contents is the key factor for class instruction. In class lecturing, there will happen something unexpected. For example, if there is a discrepancy between the learners' actual understanding and prediction, an adjustment is required to stabilize the instructional rhythm. It is not desirable that the teacher stops instruction or does not know what to do. A teacher should grasp the learners' learning conditions all the way and make an effective adjustment as quickening or slowing down the instruction progression. Of course, this is conducted on the premise of completing the instructional contents.

#### ***7.3.3 Scientific Evaluation of Learning Effect Requires Analysis of Learners***

The scientific evaluation of learning effect should be of comprehensiveness and pertinence. The learners may be examined by various methods. No matter what kind of methods is adopted, the purpose is to check the learners' understanding and application of the contents. Of course, it is based on various subject standards. There are various points of view to evaluate the instructional effect in diversified disciplines. Generally speaking, the employment of the imparted knowledge should be emphasized. Thus, various checking modes can be adopted in respect of different types of learners.

## **7.4 Comprehensiveness of Analysis of Learners**

The mastery of the characteristics of the learners may facilitate the accurate determination of the instructional contents and methods [1]. It is the basis for guarantee of instructional effect. The analysis of learners should be comprehensive. It should cover the past and the present situations. In the analyzing process, the stress can be laid on the following points:

### ***7.4.1 Analysis of Aptitude of Learners***

The aptitude of the learners mainly depends on the previous study and studying experience. The analysis should be meticulous, accurate, and comprehensive. The analysis can be focused on age, educational background, and living surroundings.

#### **7.4.1.1 Age**

The university students are in the flower of their age. They have catholic tastes and are very active in many affairs. Their consciousness is gradually strengthened. Yet, different age causes discrepancy in ability. The teacher should get to know the discrepancy of learners of different years in life experience, level of knowledge, etc. Even in the same year, due to the influence of life surrounding, family conditions, etc., there exists a discrepancy in fundamental knowledge, reception ability, thinking ability, operating skill, analysis, and inductive thought. Some learners have a wide range of knowledge, and some not; and some learners have a high skill in operation, and some not.

#### **7.4.1.2 Educational Background**

The university students have almost the same educational backgrounds. The analysis of learners should take different provinces or unique features of certain schools into consideration. The accumulated knowledge before enrollment in University can be analyzed. For post-oriented education stage, the educational background and major subjects before enrollment should be taken into account.

#### **7.4.1.3 Living Surroundings**

Diversified living surroundings may result in varied degrees of understanding. The student's academic environment should be acquired for the purpose of effective class discussion.

### ***7.4.2 Analysis of Learning Attitude of Learners***

Attitude is a kind of tendency of intrinsic reaction which one holds for a long time toward a certain matter. It is composed of cognition, emotion, and behavior tendency. The learning attitude depends on subjectivity of the learner and is the objective reaction of the learning contents. It displays whether the learner is interested in the contents and exerts a direct influence on the learning effect [2]. *I am forced to learn* and *I want to learn* will cause different results. Then, how does a teacher acquire the learning attitude? In the analysis of the learners, the analysis of the learning attitude needs a process, and it is a dynamic factor. To get to know the learning attitude, first, a meeting is suggested for the introduction of learners from some other teachers or persons, from which the teacher may get some knowledge of the learners' learning attitude. Second, a questionnaire is necessary to obtain the ideas, likes and dislikes, and choice of the learners toward the instructional contents, instructional materials, organizational method, etc., involved in the instructional design. Third, the general characteristics of the learning attitude or the possibly possessed attitude can be estimated based on some documents or teaching experiences. Fourth, the learning attitude may be assessed from the learners' cognition and performance.

### ***7.4.3 Analysis of Potentialities of Learners***

Potentialities embody the deepening understanding of a matter and thus display the quality of learners. The potentialities are gradually known by the teachers from the learners' learning process. This analysis should emphasize the development of the learners' autonomic learning. It is necessary to set up a database of the learning process containing enthusiasm, initiative and creativity, etc. Through a dynamic analysis, the teacher may guide the learners to make a scientific study and mobilize the learners' learning enthusiasm. Thus, the learners may display their actual value in the learning process and their learning capabilities are gradually enhanced [3].

### ***7.4.4 Analysis of Adaptability of Learners***

The analysis of adaptability of the learners means analysis of the learning styles of the learners. The learning style is the consistent academic tendency with personality characteristics shown in the learning process such as mood, attitude, motive, persistence, and preference for some contents [4].

The researchers make an analysis of the learning styles, which can be classified in the following methods:

#### **7.4.4.1 Independent Versus Dependent**

This classification method reflects the learner's control capability, flexibility, and analysis and integration of information. The learners of dependent type are evidently influenced by the environment. They are easier to obtain happiness in the collective environment and tend to be obedient, harmonious, and coordinative. The learners of independent type are less or even not influenced by the environment [5]. They are accustomed to think independently, not satisfied with accepting the conclusion, and not easily affected by personal emotions.

#### **7.4.4.2 Introspective Versus Impetuous**

It is divided into introspective and impetuous types according to cognitive and emotional reaction speed. The experiment shows that the impetuous learners, triggered by the superficial phenomena, are just eager to answer questions without thoughtful consideration. Their answers are quite lacking the exploration of the question and planning. The introspective learners are prudent, careful, and thoughtful. They are not eager to answer questions or draw conclusions. They are inclined to think a lot about their choices until they are doubly sure about them.

#### **7.4.4.3 Regular Versus Irregular**

Regular and irregular instructional methods may exert influence on the learners. The regular instructional is suitable for learners of anxiety reaction who are talented and eager to achieve success. The irregular instructional method which emphasizes diversification and random is of great use for low-talented and self-disciplined learners.

#### **7.4.4.4 Wholistic Versus Sequential**

The learners with wholistic strategy usually think from the objective reality to the abstract and go from the abstract back to the reality. The learners with sequential strategy think in a linear way from one assumption to the other assumption.

#### **7.4.4.5 Extroverted Versus Introverted**

The extroverted learners like to express their ideas openly with strong optimistic sense. The joy or anger is always visible on the face with a constantly changing mood. The introverted learners do not readily express their feelings. They seem to be calm but actually experiencing a surge of excitement inwardly.



The instructional process embodies two aspects, i.e., instruction by teacher and learning by learners. The mutual adaptation to each other may achieve the desired instructional goal. The acquaintance of the learning styles may be of great help to the teacher who can employ different instructional methods to the learners with various characteristics and thus promote their learning.

The comprehensive analysis of the learners may help the teachers acquire the characteristics of the learners. The instructional design should give prominence to the subjective factor of the learner so as to bring the initiative of the learners into play. It is advisable to put forward feasible strategies in the design to adjust the instructional progression, optimize the instructional contents, and enhance the instructional effect. The ideas mentioned above can be used for reference in the instructional design.

## References

1. Hou B (2004) Determination of instructional contents and methods in accordance with characteristics of learners. Basic level political work education
2. Zhang D (1997) Instructional psychology. Southwest Normal University Press, Chongqing
3. Gagne RM (1999) Principles of instructional design. East China Normal University Press, Shanghai
4. Han Y (2010) A study on strategy for difference between college english learners and instructional contents. China education innovation herald
5. Shan J, Jin C, Li F (2010) An approach to analysis of learners. Charming China

# Chapter 8

## On How to Foster the Officer Cadets' Psychological Quality of Operational Command

Rongzhi Yang, Hai Chang, Danfeng Liu, Zengjun Ji  
and Shujie Zhang

**Abstract** In order to enhance the cadets' psychological quality of operational command under the conditions of informationization, the paper expounds the characteristics of the informationized war and their effect on the commander's psychology. By way of the document analysis, questionnaire investigation, and expert interview, the authors construct the model for the commanders' psychological quality of operational command in the informationized war, i.e., firm quality of will, effective emotional control, excellent personality traits, strong cognitive ability. Combining the current institutional training status, the authors suggest a theoretical framework of the confrontation training for the cadets' operational command psychology, establishes the contents system of the confrontation training, and expands the methods and means of the confrontation training. It paves a broader way for the institutions to train the cadets' psychological quality of operational command.

**Keywords** Officer cadet · Psychological quality of operational command · Informationized war · Confrontation training

The officer cadets is an important force for the informationized war in the future; therefore, it is one of the important subjects of the current institutional education to foster the cadet psychological quality of operational command.

---

R. Yang (✉) · H. Chang · D. Liu · Z. Ji · S. Zhang  
Air Defense Forces Academy, Zhengzhou 450052, Henan, China  
e-mail: fkb\_mmes@163.com

## **8.1 Characteristics of the Informationized War and Their Effect on the Commander's Psychology**

### ***8.1.1 Characteristics of the Informationized War***

The informationized war in the future is characterized by [1]: the information resource will dominate. The difference between the informationized war and the mechanized war lies in the dominant resource which changes from material and energy to information resource. The precondition to gain and retain the initiative of war is to possess the information superiority; the battlespace is multi-dimensional. The information system links all the dimensions of the battlespace, i.e., land, sea, sky, space, electromagnetic environment, and cyberspace into an integrated battlefield, among which the war in the psychological space will become an important factor to affect the course and end state of war; the information confrontation is conducted in any dimension of the battlefield. In the informationized war, the information confrontation covers all the electromagnetic environment, cyberspace, and human psychological space of the informationized battlefield and lasts from the beginning to the end of war; the command activities are real time. The development of information technology shortens to the maximum the time interval between the decision making and action and realizes the real-time precision link between them, which hastens the operational tempo of the armed forces; the precision engagement is popularized. With the innovation of the precision reconnaissance and location, high-speed signal processing, and automatic control, the precision guidance weaponry are rapidly developed and extensively employed, and the power of destruction to the target reaches 4 ~ 10 times of the past.

### ***8.1.2 Effect of the Informationized War on the Commander's Psychology***

The complex of war increases the commander's psychological pressure. Compared to the traditional war, the informationized war is more complex. As far as the form is concerned, the informationized war is the joint warfare conducted by multiple services and branches, where all participants of the war and all struggles in the fields are interwoven together; as far as the decision making is concerned, each link of the operational command is restricted by multiple objective conditions, thus the commander must bear a heavy psychological burden. The generation gap of weapon and equipment increases the commander's psychological burden. The generation gap of weapon and equipment is obvious, and the degree of informationization differs greatly. At the first stage, the side which is advantageous in the weapon and equipment shows a proud and fanatic state of psychology, while the side which is disadvantageous in the weapon and equipment usually lacks confidence, even is scared [2]. Precision engagement and saturation attack produce

an enormous shock on the commander. At the first stage, the enemy may employ the precision guidance weapons to conduct precision engagement and pinpoint clearance against friendly main military installations. Then, they may conduct saturation attack against friendly main battle forces of the army, navy, and air force, so that the opposing force may be forced to lose the final effort to resist. Such a warfare has a great effect on the commander's psychology.

## **8.2 Psychological Quality the Commander Should Have in the Informationized War**

### ***8.2.1 Firm Quality of Will***

The commander's firm quality of will is the key to achieve victory [3]. The will is closely related to the command capability. Without firm quality of will, the commander may produce a confused and abnormal psychology after being stimulated intensively from the outside, so that he may lose the capability to think and express and the power of control. The commander with firm quality of will, even if facing danger, may change the ill situation and defeat the powerful enemy. The will is closely related with the spirit of combat. If lacking the courage to overcome difficulty, one will be in a passive situation and one with weak quality of will either wait or resist passively, even give up the combat. The will is closely related with the confidence daring to fight and win. The confidence daring to win comes from the confidence daring to fight, while a firm confidence comes from the excellent courage and the calm mind. Without a firm confidence, the inevitably ensuing must be unquiet, pessimistic, despairing, and hesitant.

### ***8.2.2 Effective Emotional Control***

The emotion is the external expression of the human psychological activity, which is of a great force to affect and communicate. The steady emotion is an important precondition of the scientific decision making. In the informationized war, the commanders need process plenty of information. In particular, in the non-congruent engagement such as the ECM warfare and cyber warfare in the informationized war, the disadvantageous conditions such as the malfunction of electronic system, paralysis of command system, intrusion of hacker may easily cause a psychological disorder among officers and men. The commander must rely on the steady emotion to guarantee the proper conduct of analysis, conclusion, deduction, and judgment. The controllable emotion is the necessary condition to command the force. The force which can win is a group of servicemen who have a strong sense of coherence, spontaneous sense of coordination, intensive sense of

obedience, and deep sense of emotion. A high spirit is an important guarantee for the morale of officers and men, a calm spirit is an important precondition for seizing the opportunity of combat, a sonorous spirit is an important embodiment for agglomerating the morale of the servicemen. Therefore, in the complex and volatile combat environment, the commander should be able to adjust consciously his/her personal emotion and behavioral way, affect and control his/her subordinates, and remove such ill emotions as scare.

### ***8.2.3 Excellent Personality Traits***

The war practice indicates that the commander's personality traits are vital to decision making. Compared to the traditional war, the informationized war is more complex in form and means; the uncertainty, suddenness, danger, and cruelty of the war increase; thus, the commander usually faces an enormous burden of psychology and mind, but the excellent personality traits are just the fundamental subjective factors to meet the challenge. The commander must chasten and edify his/her own good personality, produce an excellent quality of command psychology; he/she can adapt himself/herself to the informationized war in the future. One must chasten a wise and flexible command personality. In the dangerous situation, the commander must keep a cool mind; judge according to the actual development of the actual course of war; recognize the troublous and complex ostensible and/or false phenomenon; be calm, easy and flexible. One must chasten a brave and staunch command personality. Brave and staunch is an important factor of a commander's excellent personality, and it is also one of the most valuable personality. As a Chinese saying goes: "the brave one will win if two men fight," which is the embodiment of brave and staunch. Brave means not to fear bleeding and sacrificing and not to fear challenging the physical extremity. One must chasten a firm and resolute command personality. Indecision is always one of the military taboos. In the informationized war, the battlefield situation is interwoven and complex, so that the commander must have not only a cool and calm mind but also a resolute personality.

### ***8.2.4 Strong Cognitive Ability***

The widespread extension of the cognition space on the informationized battlefield requires that the commander must have a strong cognitive ability. The commander should have a rapid cognition speed and deep cognition degree. As the operational command system becomes flat in structure and network-dependant, the speed and precision with which to acquire, process and disseminate the operations-related information must be higher and higher, which has a higher demand for the commander's psychological and cognitive ability such as attention and feeling: the

commander must be able to transform rapidly and accurately the memorized experience solidified in the training into the operational command. The commander should be able to clarify the cognition clue in the battlefield environment. The future war is an integrated joint warfare in the conditions of informationization, so that the commander must link naturally all the element features such as the military power, weapon and equipment, logistic support with the battlefield environment. The commander must have a strong capability of logic thinking, so that he/she can clarify accurately the combat course of action, combine, and reconstruct reasonably all combat modules. The commander should have a strong capability of objective identification. As can be seen in the recent local wars in the world, both the opposing commanders are good at cheating and puzzling their opponents by the battlefield and intelligence ostensible phenomenon. Therefore, the commander must be equipped with an accurate identification capability to the enemy displayed information: he/she must be able to hold the essential, removing the false and leaving the true, in order to make an accurate judgment and proper decision.

### **8.3 Ways to Foster the Officer Cadets' Psychological Quality of Operational Command**

#### ***8.3.1 Establish Firmly the Concept that "Training Strategy Must Train Psychology"***

During the confrontation training, the institutions pay more attention to train cadets' strategy and psychology. The first is to design complicated preconditions for both sides before training so as to train strategy and psychology simultaneously. The institutions bruit conditions of weapon equipment to let cadets analyze and judge, and organize them to make well preparation of combat mobilization, psychology, and technology. The second is to preset complicated situation more approach the actual combat. Under the preset field conditions and the unified coordination of director department, the red and blue sides, respectively, accept task. The red side is taken as our army and provided with present weapon equipments, while the blue side is taken as opponent and provided with opponent's weapon equipments. The third is the two sides make a systematic summary after training. The summary is mainly about confrontation training, psychological adaptation, experience, and lesson. The confrontation training is a content-rich psychological training. The commanders, whose psychological quality are weak and spirit and emotion are easily affected by outside, must be difficult to calmly, objectively and exactly full play use of strategy. Therefore, the institutions should take the concept of "Training Strategy must Train Psychology" as guidance, organize well the confrontation training for strategy and enhance the confrontation training for operational command psychology to achieve.

### ***8.3.2 Improve the Theoretical Framework of the Confrontation Training for the Operational Command Psychology***

At present, the theory of the confrontation training for the operational command psychology in the institutions is imperfect, so that it is one of the most urgent tasks to construct the theoretical framework and carry out research. The first is the current status of research, i.e., the main theories, viewpoints, achievements on the confrontation training for the commander's operational command psychology concluded by the military experts in China and abroad. The second is the confrontation quality of operational command psychology that the commander should have, such as noble morality, profound knowledge, stable emotion, strong will, good character, and excellent strategy. The third is the confrontation capability of operational command psychology that the commander should have, such as observing ability, thinking ability, deciding ability, and reaction ability. The fourth is the commander's confrontation training theory of operational command psychology, such as the training theories on simulation confrontation, cyber confrontation, and actual combat-oriented operational command confrontation. The fifth is the commander's confrontation training theory of operational command psychology in special environments, such as the confrontation training theories of operational command psychology in the mountain/jungle warfare, urban warfare, air battle, sea battle, and contest for the dominance of islands or vital terrains.

### ***8.3.3 Establish the Contents System of the Confrontation Training for the Operational Command Psychology***

The confrontation training of operational command psychology is to construct the contents system of the psychological confrontation training by injecting the psychological stimulus element in the operational command confrontation training. The first is the psychological adaptability training. The advantageous and disadvantageous conditions in the informationized war are studied to enhance the cadets' confidence to fight and win [4]; the operational command simulation training is conducted in order to construct a new way psychological training adapted to the characteristics of the informationized war and to adjust the psychological structure and status not adapted to the new situation; the actual combat-oriented exercise is rehearsed to adapt the cadets to the change of way and characteristics of the informationized war so that they are equipped with the psychological capability of operational command under all conditions. The second is the psychological endurance training. All the likely stimuli that the commander may face in the informationized war are simulated to "shock" the cadets' psychological state for increasing their "aseismic" capability, so that the cadets may endure an extreme pressure to train their psychological endurance [5]. The

third is the psychological potential training. The potential energy of the cadets' psychological activities in the wartime is explored to mobilize and develop the potential psychology so that the energy of their psychological activity is excited to the best level, resulting in the positive reflex "the combat conditions to the psychological state."

### ***8.3.4 Expand the Methods and Means of the Confrontation Training for the Operational Command Psychology***

The commander's psychological training should be conducted after the basic psychological training is completed. The psychological quality of operational command must be enhanced by fierce confrontation training. First, the psychological confrontation training is implanted in the strategy confrontation training. The psychological interference factor of the strategy confrontation training is "amplified finitely" by simulating the actual combat-oriented environment to enhance the cadets' anti-interference capability. Second, the training is conducted in the simulated actual combat environment. The "battlefield atmosphere" is created to enhance the commander's psychological adaptability [6]. For example, when there are plenty of interference factors, the cadets may be trained as to keep, concentrate, distribute, and shift their attention; under the complex conditions, the cadets may be trained as to think flexibly so that they may analyze the enemy/friendly situations and solve all sorts of problems; in the highly tense and dangerous situation, the cadets may be trained to possess such psychological qualities as brave and calm in order to foster their psychological reliability and stability. The third is to organize the simulation training. The computer and network are used to simulate the situations where the informationized weaponry is employed, such as the enemy interference and attack. Under such conditions as the interrupted command, downsized force, uncontrollable battlefield, and lack of equipment where the psychology is overloaded, the cadets may be trained to possess the operational command capability to act according to the changing circumstances, taking it as the breach to hasten the combat will.

## **References**

1. Zheng Z (2012) Introduction to informationized War. National Defence Industry Press, Beijing, pp 24–29
2. Qu Z, Zhang Y (2009) Military groups' psychological training. PLA Publishing Press, Beijing, pp 143–145
3. Yan T (2012) Considerations on the Strategy to foster the psychological quality of the military institution cadets. Mil Psychol Training Explor 2:70–72



4. Li D (2008) On the fostering pattern of the psychological quality of the military institution cadets during new recruit training. The Dissertation of Nanjing Normal University, p 64
5. Liu H (2012) Military psychological training research. Military Science Press, Beijing, p 156
6. Chen W (2010) To foster the psychological quality of the military institution cadets with behavioral learning method [J]. J PLA Univ Sci Technol (Compr Ed) 10:50–53

# Chapter 9

## Eye-Tracking Analysis for the Disabled in the Spatial Environment

Yuanzhe Fan, Weimin Wang, Yuhui Xin, Meiyu Lv and Lan Wang

**Abstract** In order to examine the cognition behaviors of the physically disabled in the spatial environment such as subway system, we implemented the onsite eye-tracking experiment in the real subway environment. We hired 12 physically disabled people who sit on the wheelchairs and conducted certain experiment at National Library Station, Beijing Subway. By using SMI-HED eye tracker, we collected physiological data concerning disabled's visual cognition performances such as fixation, saccades, and diameter of pupil and. Afterward, we implemented quantitative data analysis and established math model through correlation analysis between different variables. We found there remained a correlation between variance of saccade's displacement with task time.

**Keywords** Eye-tracking · Cognition analysis · Spatial environment · The disabled

### 9.1 Introduction

As an increasingly large fraction of human knowledge migrates to the World Wide Web and other information systems, finding useful information is simultaneously more important and much more difficult [1]. Nowadays, eye-tracking experiment has become a popular tool to investigate into user's visual cognition. A majority of certain experiments have been focused on examining the usability of Web layouts, users' attention on Web, and mobile devices. Using eye tracking in the evaluation of Web search interfaces can provide rich information on user's information search behavior, particularly in the matter of user interaction with different informative components on a search results screen [2]. These researches focused on the interaction between user and interface in a restricted context.

---

Y. Fan (✉) · W. Wang · Y. Xin · M. Lv · L. Wang  
Automation School, Beijing University of Posts and Telecommunications,  
Beijing 100085, China  
e-mail: fanyuanzhe1106@gmail.com

What we are interested in is to examine the cognition of human under the broader scope of environment. With the development of ubiquitous computing, we live among invisible computers, with user interfaces that consist of sensing systems providing contextual information that drives their actions [3]. We measure visual attention with eye tracking, a methodology commonly used in HCI research, especially in multimodal interaction. Head-mounted (mobile) eye trackers allow us to measure visual attention also for large-scale spaces, such as outdoor urban settings [4]. Environment has a spatial context, with multiple divisions and numerous information types. Meanwhile, factors influencing the communications between human and environment have dramatically increased such as noise, light, and density of people. These studies are mobile eye tracking (MET), extended to large-scale spaces [5]. Compared to static eye tracking, MET methods provide a good solution for studying perception with the freedom of movement and variable contexts that characterize natural vision. The example is taken from a spatial cognition research context. We emphasize the mobility of the participant, and less the mobility of the device. We also introduce location-aware mobile eye tracking (LA-MET) and describe the conceptual differences to related work in MET.

The total amount of the disabled people has risen to 0.9 billion, takes up nearly 1/10 of all population. In China, the total amount of such disadvantaged people is 60 million, takes up 5 % of all [6]. However, there are few research focused on these disadvantaged people. In this paper, we analyzed the cognition behaviors of the physically disabled people in the subway system.

Due to the immobility of the disabled people, incompleteness of accessibility, and discrimination of the society, most disabled people would prefer not to use public transportation. Based on our field investigation and user interview, the physically disabled people usually carry the wheelchair for their transportation vehicle. Since their viewpoints are lower than the normal people, the disabled people often face great difficulty in receiving navigation information in the spatial environment; their processes of perceiving information are more likely disturbed by the surrounding environment. Implementing in-depth research on the disabled people would be meaningful since we could discover the specialty of the disabled's cognition model, mental model, and patterns of information receiving. Achievements of such researches not only would help us understand the characteristics of cognition for the disabled in the spatial environment, but also would contribute to the establishment of non-barrier environment (Fig. 9.1).

## 9.2 Experiment Design and Procedures

Figure 9.2.

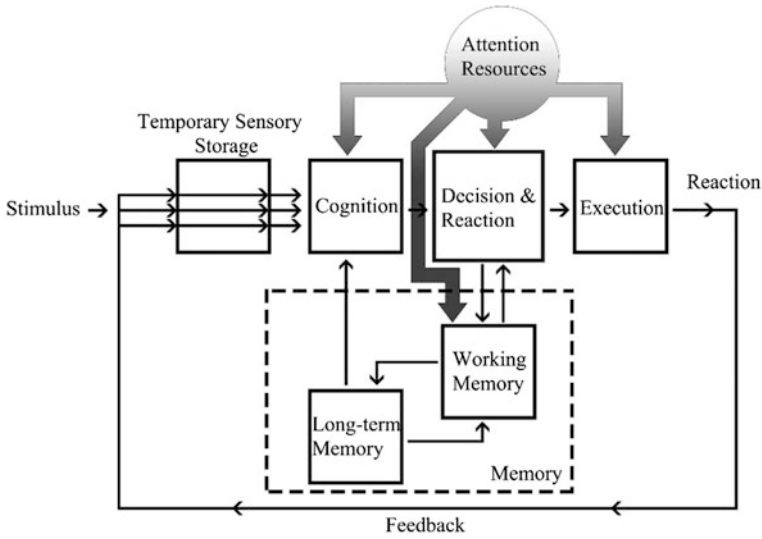


Fig. 9.1 The cognitive model of Wickens [7]



Fig. 9.2 Captured in field investigation

### 9.2.1 Calibration

It is really challenging for us to conduct calibration in the spatial environment since accuracy for SMI-HED eye tracker is ensured when the distance between test taker and visual stimulus is constant. However, there does not exist such constant in the spatial environment.

Moreover, complex light sources added great difficulty in tracking the corneal reflection (CR) of the i-View camera.

We set the place of calibration in the spatial environment with less light interference. We selected a wall as screen of calibration and asked test person to look at five specific points adhered on the wall. The distance between test person and wall was decided based on the measurement of suitable distance when perceiving navigation information in the spatial environment.

### ***9.2.2 Pre-experiment Adjustments***

In order to reduce the cognition differences among these participants, we presented them the same paragraph of informative words and made sure they could recognize relevant details appeared in the paragraph. Such pre-experiment adjustments would make sure they went through a thorough cognition process and maintained a similar cognition condition.

### ***9.2.3 Searching for Navigation Information in the Platform***

We arranged the disabled participants on the platform of subway environment. Firstly, we provided participant the place of departure A and destination B. Then, we asked participant to search for guided information to find the proper route based on the information in the spatial environment.

### ***9.2.4 Evaluation of Searching Performance***

Afterward, we made an evaluation on their search performance by examining the accuracy of transfer spots they provided.

## **9.3 Methods**

### ***9.3.1 Apparatus***

Eye-tracking experiment was performed using the SMI-HED eye tracker paired with 13" monitor. The eye tracker sampled the gaze of users at the rate of 50 Hz. We have also used the video-based i-View system to record video in the eyes of participants.

### ***9.3.2 Participants***

We recruited 12 physically disabled people who used wheelchair as their transportation tool. Due to the immobility of their bodies, they seldom used subway in their daily lives. None of them had experience in using the HED eye tracker. After excluded two incomplete pairs of data, we got 10 valid experiment samples.

### ***9.3.3 Experiment Location***

Beijing Subway, National library station, Entrance F.

## **9.4 Data Analysis**

### ***9.4.1 Data Collection***

Export .txt raw physiological data from experiment center 3.0 such as saccades, fixations, and blink, distributed by chronological order.

### ***9.4.2 Data Integration***

Match time spots in recording video with time spots in exported raw data. We looked for significant behaviors of users that marked the beginning and end of an event.

### ***9.4.3 Data Classification***

We classified whole data into several parts, saccades data, fixation data, and blink data. Then, we combined the relevant data of all test takers accordingly.

### ***9.4.4 Data Mining***

We completed this process with the knowledge of statistics and put all raw data into SPSS. Firstly, we calculated average and variance and made the fundamental analysis of data. Then, we tried to figure out the correlation between each physiological data. Finally, we established math model for cognition of the disabled in the subway and achieved meaningful conclusions.

## **9.5 Results**

### ***9.5.1 Fixation***

1. Firstly, we extracted raw fixation data from eye tracker: duration of fixation, dispersion in X&Y axil, coordinate of fixation (x, y), and average of pupil's diameter.

**Table 9.1** Linear and quadratic fitting results

$F(x)$	Model collection					Parameter estimates		
	$R^2$	$F$	df1	df2	Sig.	Constant	$b_1$	$b_2$
Linear	0.490	7.701	1	8	0.024	20.493	0.001	
Quadratic	0.867	22.888	2	7	0.001	-3.325	0.006	-1.302E-7

*Dependent variable* task time

*Independent variable* variance of saccades displacement

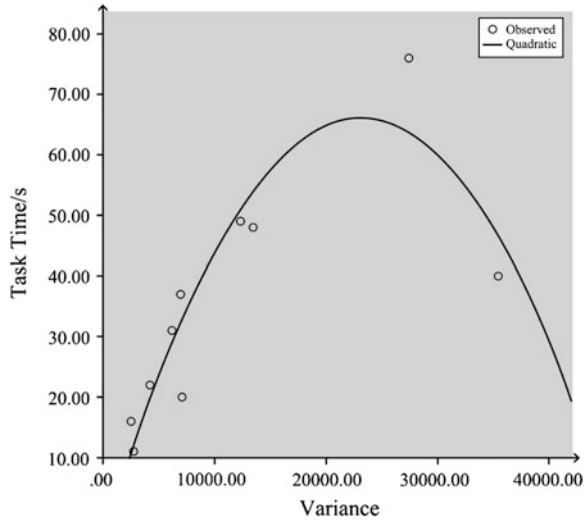
2. Calculating area of fixation dispersion per time by multiplying parameters in X&Y axil dispersion.
3. Calculating the mean value and variance of diameter of pupil, X&Y dispersion, and area of fixation dispersion. Then, we conducted linear fitting and secondary fitting for the correlation curve between these physiological data with task time. However, such correlation remained not obvious and needs to be substantiated further.

**9.5.2 Saccade**

1. Extracted raw saccade data from eye tracker, duration of saccade, start coordinate of each saccade ( $x_1, y_1$ ), and end coordinate of each saccade ( $x_2, y_2$ ).
2. Calculating displacement ( $D$ ) value for each saccade.

$$D = \sqrt{[(x_1 - x_2)^2 + (y_1 - y_2)^2]}$$

**Fig. 9.3** Quadratic fitting results



3. Conducted linear fitting and secondary fitting for the correlation curve between displacement of saccade with task time.

As can be seen from the linear curve and secondary curve, there remained a clear correlation for the secondary fitting curve between variance of saccade's displacement ( $V$ ) with task time ( $T$ ). Equation for the secondary fitting is as follows (Table 9.1, Fig. 9.3).

$$T = 0.006V^2 - 1.302E - 7S - 3.325$$

## 9.6 Conclusion

By implementing onsite eye-tracking experiment for the disabled in the subway, we focused on cognition behaviors of the disabled when searching for information in the spatial environment. By conducting data analysis on the physiological data exported from eye tracker, we examined the correlation between displacement of saccade and dispersion area of fixation with task time. Then, we found the apparent correlation between variance of saccade displacement with task time which would be helpful for us to find out influential elements of perceiving spatial information for the disabled.

## References

1. Cutrell E, Guan Z (2007) What are you looking for? an eye-tracking study of information usage in web search. In: Proceedings of the SIGCHI conference on human factors in computing systems
2. Al Maqbali H, Scholer F, Thom JA, Wu M (2013) Using eye tracking for evaluating web search interfaces. In: Proceedings of the 18th Australasian document computing symposium
3. Smith JD, Vertegaal R, Sohn C (2005) ViewPoint: lightweight calibration-free eye tracking for ubiquitous handsfree deixis
4. Giannopoulos I, Kiefer P, Raubal M (2012) GeoGazemarks: providing gaze history for the orientation on small display maps. In: Proceedings of the 14th ACM international conference on Multimodal interaction
5. Kiefer P, Straub F, Raubal M (2012) Towards location-aware mobile eye tracking. In: Symposium on eye tracking research and applications
6. Zhang Jun (2013) Data analysis of national disabled people's basic database. *Disabil Res* 3:76–79
7. Wickens C, Hollands J (2000) *Engineering psychology and human performance*, 3rd edn. Merrill, Columbus



# Chapter 10

## A Research of NATO Forces Fitness on Man–Machine Operation and Its Enlightenment

Weizhong Liu

**Abstract** Numerous working groups in NATO troops have launched many research findings on army physical fitness of the human–machine job, covering human medicine, exercise science, nutrition, injuries, rehabilitation, and female military personnel policy in humanities and social sciences areas. These researches on physical effectively stimulate the promotion of human–machine operation. The features of the research are as follows: by detailed analysis of operations tasks of man–machine combination, march, mining, and crafts were determined as NATO’s typical physically demanding military tasks. According to the different periods of military tasks, trans-department research groups were set up to establish human–machine job fitness model and training schedule. By long-term track and research on body job capacity, the military task effectiveness was analyzed and upgraded based on body activities; the research method on soldiers’ body job capacity emphasizes science, quantitative, using more integrated research discipline, not simple of overview or illustrates; meanwhile, from the perspective of soldiers body capacity training and supports, NATO army also study on policy and social problems (health, pregnant, men and women soldiers team action, sexual harassment). The enlightenment is as follows: First, studying ideas should enhance the analysis of occupational physical fitness; second, the research direction should focus on man–machine operations closely connected with physical fitness avoiding simply physical study; and third, innovate means of physical exercise and set up new military sports events associated with military skills to train and improve soldiers’ physical fitness.

**Keywords** NATO · Man–machine operation · Physical fitness · Military physical education and sports

---

W. Liu (✉)

Editorial Office of Journal of Military Physical Education and Sports,  
Guangzhou 510500, China  
e-mail: jtylwz@163.com

© Springer-Verlag Berlin Heidelberg 2015

S. Long and B.S. Dhillon (eds.), *Proceedings of the 14th International Conference on Man–Machine–Environment System Engineering*,

Lecture Notes in Electrical Engineering 318, DOI 10.1007/978-3-662-44067-4\_10

## **10.1 Task Group and Main Contents of Physical Fitness Study on NATO Troops Man–Machine Operation**

NATO troops began their researches on army physical fitness in human–machine operation as early as 1975, set up the 4th, 8th, and 17th research group of research study group (RSG) and the 8th team of the defence research group (DRG) [1]. Research contents mainly consist of human–machine environment adaptation, nutrition, training biomedical, and female soldiers' contents.

### ***10.1.1 Research of Human–Machine Environment Adaptation***

During military training, military staff must have perfect physical fitness to accommodate to severe condition changes, which included human, machine, environment etc., providing sufficient cognitive and movement abilities, such as lasting cognitive and accurate operational performance under the conditions of sleep deprivation, changes in time zone, influence of environment, and drugs. By means of studying the medical characteristics of physical training (age, sex, overtraining, injury, cardiovascular disease, risk factors and protect, heat and cold injuries, health and endurance, exercise and health), The Fourth Research Group has [2] gauged physical attributes and body compositions of human–machine operation and carried out researches on human–machine environment adaptation.

### ***10.1.2 Research of Military Nutrition***

Military diet nutrition directly affects strength of the army. Main contents concerned by the eighth research group include heat and rational rationing of various foods, relation between nutrition and cardiovascular diseases, soldiers' health and weight control, etc. [3]. Under the different conditions of daily survival, emergency situations, battle and fight, etc., study on the relationship between nutrition and physical fitness may provide nutrition policy for the army and provide food supply program to meet human–machine operation performance.

### ***10.1.3 Research of Biomedicine in the Military Training***

Military personnel improve their physical fitness through physical training besides military skill training to meet the needs of military tasks. Physiological problems during the physical training include reaction to training, muscular strength and

endurance, flexibility, and body composition factors. Research may let the choice of oxygen ability training program more scientific; adopt reasonable training strength, frequency, and continuous variables; reduce the happening of wounds during the military training. Fourth and seventeenth research groups did scientific research from different levels [4].

#### ***10.1.4 Female Soldier***

NATO DRG eighth group [5] specially research many performance-related issues of female soldiers in the sea, ground, and air forces, such as design of female soldiers' clothing, individual equipment and operation positions from anthropometrics, gender differences in hot and cold environments, cognitive differences, women in the team (men and women mixed coupling or all female team similar with tradition of all male soldiers), and policy and social issues (health care, pregnancy, and sexual harassment).

#### ***10.1.5 Research Tasks Since the New Century***

Since the new century, NATO's military tasks (NATO in the twenty-first century) have been changed [6], which requires the soldiers' physical ability to adapt to the transition shift in the human-machine operation. A code 019 task group was founded for the purpose; it researched and determined physical demands of the military personnel in their combat missions, prevented excessive fatigue, and reduced military training injuries and diseases in combat.

### **10.2 Features of Research of NATO Forces Man-Machine Operation Physical Fitness**

#### ***10.2.1 Detailed Analysis of Operations Tasks for the Man-Machine Combination***

Research objects of army soldiers' physical ability directly aim at the physical activities of military action post position, operations, and man-machine combination. By referring the basic task lists of military actions, which are actually performed and recorded in the relevant files, regular tasks are analyzed for different countries during the humanitarian assistance, peacekeeping, conflict resolution, counter-terrorism operations, etc. Research groups determined tasks which have representative physical requirements in NATO's military tasks: military tasks with common physical demands including marching, digging, and manual operation.

### ***10.2.2 Division Collaboration of Trans-Department Research Group***

A trans-department research group is set up according to military tasks in different periods, especially research physical demand models and the training plans of human-machine operations. The rapid developed modern technologies are both direct combat force and combat multiplier, bring huge power to military revolutions, and give birth to new war form and combat style. Changes in combat style directly or indirectly affect soldiers' physical attributes demands, when soldiers perform the military missions; development in military science and technology also bring new changes to soldiers' operation range and form. Therefore, NATO forces emphasize on the researches of military actions on the human-machine operation physical fitness in different periods, and special research groups have been set up aiming at demands of military mission, test type, and job contents of military man-machine operation and determine common operation types.

### ***10.2.3 Longer Term Follow-Up Research***

Study physical operational capabilities by long-term follow-up, and analyze and upgrade the military mission effectiveness by means of physical activities. View from following research literatures from all eras: Gould made comparison on tools used by soldiers to mine trenches in 1957, reduced weight of picks and shovel through experimental researches, and upgraded job capacity [7]; Jorgensen et al. made physiological problem researches on physical limits to repeat lifting weights in the maximum frequency in 1974 [8]; Garg et al. made assessment researches of mechanical and physiological metabolism on soldiers' operation posture and job effectiveness in 1979 [9]; Taboun et al. set up forecasting models for manual handling supplies during a joint mission (CTMMH) in 1984 [10]; Lee studied Canadian army's aerobic and anaerobic fitness standards associated with the military tasks in 1992 [11]; Kraemer et al. carried resistance training researches for female soldiers in 2001 and analyzed the influence on strength, effectiveness, and occupation operation ability in 2001 [12]; Pandorf et al. made reliability evaluation study by military occupational physical ability test in 2003 [13].

### ***10.2.4 Adopt a Quantitative Research Approach***

The research methods and means of the soldiers' operational capabilities emphasize on scientific, quantitative use of multidisciplinary research, not a simple summary or explanation. Studies in all periods focus on application of the latest research results, including exercise physiology, dynamics, sports training, and

ergonomics, making scientific quantitative study on military operational capabilities of the body. The paper places emphasis on modeling and scientific assessments through experimental studies. See from the documentation, most experimental researches are based on experiments, as well as conclude data to assess and inspect the predict results. It is also found that NATO forces have carried on many studies in the fields of military physical training, security policies, and social issues (health care, pregnancy, men team to action, sexual harassment).

## **10.3 Enlightenment**

### ***10.3.1 Enlightenment on the Army Physical Fitness Research Logic Thought***

There may be different logic thought in the research and exploration of inherent law of matters, and the same goal can be eventually reached; or, research purposes can be realized from different paths and sides, so as to reveal the general or special laws of matters. The physical researches of our army are carried out more from the logic thought “physical training—specific object (soldiers) engaging in physical training (military sports)—improve army fighting.” It can reach similar effects of the logic thought of NATO forces, which is “military action (human–machine operation) task list—soldiers’ body capacity needs—body fitness training or sports exercise provides body capacity.” But in our previous studies, most researches stayed in the first step “physical training,” and the researches on specific objects (soldier) in the second step mainly focus on soldiers’ strict discipline and higher requirements of movement quality; research the training program and means and methods of organization, to improve soldiers’ physical fitness test scores. It is generally regarded that the improvement in the results of physical examination will also improve capability of the soldier’s body and then improve their underlying strength in combat. This awareness is not wrong, and for the army-wide, the test levels of basic physical fitness testing items can really reflect soldiers’ basic physical ability and facilitate the assessment and comparative assessment of the whole army, but this is not enough. Fulfilling the responsibilities and tasks in our army has proposed new requirements to the soldiers’ body capabilities, along with the social and technological development and military tasks change. What requirements are included and how to implement these requirements? How much relevance are there between contents and standards of military personnel physical training in the past and at present, and body capability demands for human–machine operation (military physical training or actual military operations such as fitness training for troops marching, digging trenches, filling shells, such as flights, transporting goods, back or operational capability upgrade how relevance and reliability). The writer suggested that researches on our soldiers’ physical training may refer to the logic thought of NATO force research, starting from the military operational tasks, studies on appropriate methods, and contents for physical training.

### ***10.3.2 Enlightenment on the Army Physical Fitness Research***

As mentioned before, the researchers will have different directions of research if guided by different logic thoughts. Our military sports begin from sports training and reveals the general principal, method, tool, organization, management, examination, and evaluation for soldiers engaging in sports training. Many research fruits have obtained on the physical training plan, training method, physiological and biochemical evaluation, etc., and force military physical training achievements have been improved to a certain extent, and guarantee soldiers have good physical conditions to perform military tasks. NATO forces started from military combat tasks, researched the typical representative of physics (labor) in the human-machine operation of the military operation, measure energy (oxygen, non-oxygen, movement quality, etc.) consumed by the physics, and forecast and select physical sport items, which are equivalent to the army's operation energy. By some period of training to check the correlation between the operation and physical trainings, contents and standards of physical training items are drawn, which can reflect capacities of human-machine operation. Therefore, research men in NATO forces pay more attention to the following research directions: the correlation between military physics and operation, efficiency of training effect, using suitable physical training to replace military operation training; providing enough strength, speed, reaction ability to reduce military training wound, sex difference in the military training, group and single soldier standards of physical operation ability, standards of body health level etc. therefore, the writer suggestion the research of military physical training needs to be rooted in the troop and faces realistic of the troop training, and directly promote the physical efficiency of military operation. To those normal physical trainings, there are many researches, which only need serious reference and consideration, and do not need repeat research on pure physical training plans and methods, but put emphasis on the demands of human-machine operation body quality and improvement means during the battle training.

### ***10.3.3 Enlightenment of Developing Military Sport Items Inspiration***

Military sports draw high attentions as military combat skills, but soldiers' physical factors in the modern wars are reduced dramatically, and soldiers' physical fitness has transformed from direct combat skills into fighting protection component or safeguard methods. Most military sports have transformed into the emerging mass sports, and military characteristics are hard to maintain. For example, popular outdoor sports in modern society include partial or all military sports, such as hiking, camping, rock climbing, swimming, field shooting, obstacle running, directional cross-country, and skydiving. In recent years, military sports

have turned to raise the level of army physical fitness, as well as increase physical fitness training and researches, and promote soldiers' physique being improved quickly. However, some armies replace training projects with examination projects, simplify military physical training into training for simple physical assessment projects, and weaken the spread of military sports program to a certain extent.

There are research bases for using simple physical training evaluations as means to assess the fitness level of human-machine operation (NATO forces have done a lot of research on the degree of association). However, the military physical training does not simply raise the level of physical fitness, and the more important is to improve the physical operational capabilities required by the combat, or direct combat skills to play. In the theories of sports training, no matter monistic training theory or the theory of special training, they all emphasize the importance and action of specific technical training. Hence, simple physical training methods are effective to improve the skill or abilities of military operations, but they are not necessarily the best ones and need to be evaluated. While carrying out some military missions, man-machine operation requires military personnel to have a corresponding quality of strength, speed, stamina, and agility, plus of specialized brain training. Therefore, if compared with the simple physical training, specialized human-machine operation skills training can improve physical fitness required by military operations and establish as well as strengthen human-machine operation brain links, so as to let military skills more skillful and effective. It is recommended to open new military five items, taking common basic operation items (loading march, mining trench (filling sandbags), lifts ammunition box (or gas can) to truck tank, handling ammunition box (or gas can) to reentrant run and armed running) as the military sports items. Contest race activities not only can promote big improvement in the army's military basic skills, but also can fill with new energy and vitality for the military sports projects.

## References

1. RTO technical report TR-HFM-080 (2009)
2. RSG 4 on physical fitness with special reference to military forces. AC/243 (Panel CIII) D/125)
3. RSG 8 on nutritional aspects of military feeding (military nutrition). AC/243 (Panel 8 RSG8)D/9)
4. RSG 17 on biomedical aspects of military training. AC/243 (Panel 8/TR16) 0875-94)
5. Optimizing the performance of women in the armed forces of NATO. AC/243 (Panel 8) TP/13
6. NATO in the 21st century at <http://www.nato.int/docu/21-cent/html>
7. Gould AH (1957) User trials of the comparative efficiency of entrenching tools and lightweight picks and shovels. Army operational research group memorandum no. H.5
8. Jorgensen K, Poulsen E (1974) Physiological problems in repetitive lifting with special reference to tolerance limits to the maximum lifting frequency. *Ergonomics* 17(1):31-39

9. Waters TR, Putz-Anderson V, Garg A, Fine LJ (1993) Revised NIOSH equation for the design and evaluation of manual lifting tasks. *Ergonomics* 36(7):749–776
10. Taboun S, Dutta SP (1984) Prediction models for combined tasks in manual materials handling (CTMMH). In: *Proceeding of the 1984 international conference on occupational ergonomics*, pp 551–555
11. Lee SW (1992) Task related aerobic and anaerobic physical fitness standards for the Canadian army. Doctor thesis, Department of Physical Education and Sport studies Edmonton
12. Kraemer WJ, Mazzetti SA, Nindl BC, Gotshalk LA, Volek JS, Bush JA, Marx JO, Dohi K, Gomez AL, Miles M, Fleck SJ, Newton RU, Hakkinen K (2001) Effect of resistance training on women's strength/power and occupational performance. *Med Sci Sports Exerc* 33:1011–1025
13. Pandorf CE, Nindl BC, Montain SJ, Castellani JW, Frykman PN, Leone CD, Harman EA (2003) Reliability assessment of two militarily relevant occupational physical performance tests. *Can J Appl Physiol* 28:27–37



# Chapter 11

## Analysis of the Psychological Connotations of the Military College Course Designer

Hua Li, Huifang Wang, Jianhe Wang, Guoxiang Tian, Jie Xing  
and Weixin Liu

**Abstract** The purpose of this thesis is to improve the course designer's psychological quality and then to enhance the course quality. With the method of theoretical arguments, the psychological connotations of the course designer are analyzed, and the growth point of the psychological mental process and the personality psychology of the course designer in the military colleges are proposed to be concerned about, so as to enhance the course quality by improving the course designer's personality and developing their potential.

**Keywords** Military colleges · The course designer's psychology · Connotations · Analysis

### 11.1 Research Purpose

Course design is the core and guidance of all that is concerned about the course [1]. Without scientific design, there will be no course implementation blueprint that meets the practical needs. In recent years, although there is quite a lot research about the course design, most is focused on the object—the course—and few is about the course designer, especially their psychology. In fact, the course design is the process that the subjective works on the objective and the psychological factors of the course designer affect the design and implementation to a great extent. With the deepening course reform, widening course research areas and especially the course design as a strong word in the present course area research and practice, the course designer's psychological factors such as thought, emotion, attitude, and will are paid more and more attention to. On both the subjective and objective aspects, the psychological quality of the course designer needs to be improved.

---

H. Li (✉) · H. Wang · J. Wang · G. Tian · J. Xing · W. Liu  
Air Defense Forces Academy, Zhengzhou 450052, China  
e-mail: fkb\_mmes@163.com

Therefore, the concept of the course designer's psychology is proposed to meet the needs of the course design. This concept can also help to analyze the psychological factors in the course design process and their important functions, to improve the course designer's psychological quality and to provide a new orientation for the course development and design.

## **11.2 Psychological Connotations in the Course Design of the Military Colleges**

### ***11.2.1 The Course Design and Psychological Process***

The essence of the course design is a kind of psychological activities, which is the reflection of psychological process and personality in the course design process. Because both of a series of specific design activities participated by the course designer and the service objects of the course design are to make the learners know how to learn, the course design process is a thinking process with distinctive orientation, an continuous emotion investing process, a willpower process and a personality exhibition process as well as the product of the comprehensive psychological function

Through the theoretical research and argumentation, the course design result proves to be the product of the comprehensive psychological function, which is proceeded through the thinking activities. The broadness, profoundness, creativeness, criticalness, flexibility, logicalness, and so on will absolutely have effect on the result of the course design. The perception way to problems, the information processing capability, the willpower, personal values, emotions, and character traits will also penetrate into the course design process [2]. All these will comprehensively constrain or determine the way to define problems, the broadness of materials, and the deepness of the problem analysis, the way to develop optional programs and the quality of the optional programs as well as the boldness and decisiveness to implement the plan.

### ***11.2.2 Psychological Connotations in the Course Design***

Based on the above analysis, the course designer's psychology refers to the designer's subjective reflection of the course design, the sum of the designer's psychological process and character psychology, and the interactive process of various psychological factors in the course design process. What needs to be emphasized is that the research objects of the course designer include two groups of people. One group is the main course designers, including college administration personnel and teachers, and the other one is the participants in the course

design, namely cadets. These two groups of people act together in the course design process.

The research contents of the course designer's psychology include two parts. One is the psychological process of the course design community, which means to study the course designer's cognition, emotions, and will in the course design process. The other is character psychology of the course design community, which means to mainly study the course designer's character tendency and traits.

The basic tasks of the course designer's psychology study are to guide the course design practice and to enrich and develop the course design theories on the one hand. On the other hand, it is to evaluate the psychological quality of the course designer and to provide psychological assistance.

### ***11.2.3 Psychological Connotations in the Course Design of Military Colleges***

The nature of the military college courses is the general design and arrangement of the education aim, education contents, and study manners of a certain major in the military colleges [3]. The military college courses are professionally directive because of the constraints of the needs of military construction and the future war, the development of the military technology, and the physical and psychological development of the cadets and the course designer. The military course design emphasizes the military college education characteristics when consistent with the normal course design theories.

The course designer's psychology in the military colleges refers to the psychological process and character psychology reflected by the course designer in course design activities when trying to meet the requirements of training qualified military personnel under the specific education environment. The psychological connotations of the military college course designer elaborate the following points: Firstly, the military college course designer's psychology has the psychological characteristics of professional military personnel except the normal psychological characteristics; secondly, it is the military colleges that determine the course design to be multi-level and multiple values, with the application and practice as the main course orientation, and have higher requirements for the psychological quality of the course designer; and thirdly, on the whole, the analysis of the course designer's psychology in the military colleges emphasizes the course's characteristics and special requirements in the military colleges more when in conform with the normal patterns and rules of the designer's psychological research. All the above factors result in that the military college course designer's psychology reflects the special thought, emotions, attitude, wills, and characters of the military course designer—servicemen from both the psychological process and the character psychology.

## 11.3 Conclusions

The analysis of the course designer's psychology in the military colleges should be aimed at promoting the course designer's psychological quality and enhance the course design quality by studying their unique psychological process and character psychology and finding the growth points.

### *11.3.1 The Psychological Process of the Military College Course Designer*

The psychological process of the military college course designer includes cognition, emotions, and willpower, the three basic categories, of which the thinking process, the emotion investing, and the willpower are the study emphasis of this thesis.

#### **11.3.1.1 The Thinking Process of the Military College Course Designer**

The thinking process of the military college course designer refers to the process that the course designer analyzes, integrates, compares, abstracts, and concludes related information according to his own knowledge and experience. Specifically speaking, it is a series of thinking operation of the course designer to choose the course design concept, set the thinking orientation, lock the aim, and construct the course system. In this process, to solve problems is the most important thinking activity, "which can be considered as the most common form [4]."

The problem solving in the military college course design includes the following basic stages, characterization of the problem, program design, program implementation, and result assessment. In the four stages, the thinking characteristics, which are the general, indirect, and integration characteristics, of the military college course designer should be fully reflected. In the thinking process, the following characteristics should also be contained: firstly, to be profound and broad; secondly, to be independent and critical; thirdly, to be flexible and agile; and fourthly, to be logical.

#### **11.3.1.2 Emotion Investing in the Military College Course Design**

Emotion is the experience of people's attitude toward the objective existence, which affects the task completion. Emotion investing in the military college course design refers to the emotion investment direction, extent, continuance, and the emotional communication of the course designer in the detailed course design process.

The military college course designer should learn how to control their emotions and change their roles in the course design process through effective emotion investing.

### **11.3.1.3 The Willpower in the Military College Course Design**

The willpower in the military college course design refers to the positive and dynamic process that the willpower adjusts the course design process, which can be divided into two stages. One is the course program design stage, and the other is the stage that is to implement the course program into the microscopic course design. The first stage is the willpower's initial stage. After enough cognition preparation, the main task of the course designer is to draw up the personnel training program and curriculum standards. Optimization of the design is their aim. Under this aim, the course designer should understand their tasks and conduct complicated design tasks with the support of the strong willpower. The second stage is the willpower strengthening stage. When the course program being implemented, there will be a lot of new conditions and problems, difficulties, and contradictions with the original design, which needs the course designer to make a lot of efforts and keep the strong willpower. It is the key step to convert the willpower into actions.

## ***11.3.2 The Character Psychology in the Military College Course Design***

The character psychology in the military college course design mainly studies the character tendency, traits, and adjustment of the course designer. The study emphasis of this thesis is the course designer's values, creative capability, and self-adjustment capability.

### **11.3.2.1 The Values of the Military College Course Designer**

Values are “the psychological tendency system used by people to judge the value standards and guide their behaviors [5].” The values of the military college course designer are stable and systematic opinions toward the military college course designed, which are formed by the designer on the basis of their cognition of the military college course design theories and practices.

Under the guidance of the significance of training qualified military personnel and forming correct course design values, the scientific course theories should be developed, and the actual demands of the military construction and the future war on the personnel quality should be grasped. Therefore, the course design should be

studied and planned carefully, so as to build a scientific, effective course platform for the training of the qualified military personnel, which is in conform to the military education rules and has the characteristics of the military college education [6].

### **11.3.2.2 The Innovation Capacity of the Military College Course Designer**

The innovation capacity is the core in a person's capacity structure and the most active and viable one in the character study area. The innovation capacity of the military college course designer refers to the course development capacity, course integration capacity, course organization capacity, and course prediction capacity displayed by the course designer in the course design process.

### **11.3.2.3 The Self-adjustment Capacity of the Military College Course Designer**

The self-adjustment capacity is the most important part of the character adjustment. The self-adjustment capacity of the military college course designer is displayed in self-adjustment, self-monitoring, self-motivating, self-education, and so on in the course design.

## **References**

1. Huang guanxiong, Cai qingtian (2005) Course design—theory and practice. Normal University Press, Nanjing, p 28
2. Alsobel et al (1994) Education psychology—the cognitive view. Yu Xingnan et al translated (1994). People's Education Press, Beijing, p 56
3. Zhu ruke, Dong huiyu (1999) Modern military curriculum theory. Military Science Press, Beijing, p 58
4. Lu jiamei, Wei qingan, Li qiwei (2004) Psychology—the basic theory and education application (revision). Shanghai People's Press, Shanghai, p 97
5. Lu jiamei, Wei qingan, Li qiwei (2004) Psychology—the basic theory and education application (revision). Shanghai People's Press, Shanghai, p 293
6. Wang Z, Jiang J (2006) Walk up to continuable development—The only way military education. PLA's Press, Beijing, p 123

# Chapter 12

## Study on Comprehensive Quality Evaluation of Military Science Postgraduate

Shenhua Huang, Hongyan Ou, Lin Chen, Chenhui Li, Guoan Shi and Huiyong Wang

**Abstract** For raising the cultivation quality of military science postgraduate cultivation and pushing the reforming of military science postgraduate education, this text carried on a thorough study to the topic of comprehensive quality evaluation of military science postgraduate. The essay established the factor system, the weigh system, and the model system to comprehensive quality evaluation of military science postgraduate and expounded the evaluation process. The related study and achievement of this text had a lot of aggressive theory meaning and practice value to pushing the progress of military colleges and schools education reforming, raising the quality of the military talented people, and strengthening fighting efficiency of the army forces.

**Keywords** Military science postgraduate · Comprehensive quality · Evaluation system model

### 12.1 Introduction

Military talented people are the key to troop's construction and the core to strengthening fighting efficiency of the army forces with science and technology. Military colleges and schools are the base to cultivating military talented people, and they carry sacred mission to strengthening fighting efficiency of the army forces. Military science postgraduate is an important part of the army forces especially the main source of commander, and it will provide strong intelligence guarantee with technique to troop's construction. It is very necessary to evaluating the comprehensive quality of military science postgraduate with a reasonable method.

---

S. Huang (✉) · H. Ou · L. Chen · C. Li · G. Shi · H. Wang  
Air Defense Forces Academy, Zhengzhou 450052, China  
e-mail: fkb\_mmes@163.com

## 12.2 Evaluation Method

Qualitative assessment and quantitative analysis are the main methods to evaluating the comprehensive quality of military talented people. Each of the two methods has merits and shortcomings. For improving objectivity and impartiality of evaluation result to military science postgraduate, a comprehensive evaluation method was used in this text.

## 12.3 Factor System of Evaluation

Military physique, military kill, and military intelligence are the main ability of military science postgraduate. Military physique means the healthy condition of physiology and psychology. Military kill indicates the well-trained degree of operating which includes technology, speed, accuracy, and so on. Military intelligence symbolizes creative imagination, creative thinking, and creative power in military domain.

### 12.3.1 *Military Physique*

Military physique is the “cornerstone” to improve the comprehensive quality of military science postgraduate [1]. Good military physique is the basically constitute part of soldiers’ fighting efficiency; any advanced weapon cannot replace the strong and healthy soldiers in the battlefield [2]. Military physical qualities of military science postgraduate include the following five abilities: first, body character; second, speed and flexibility; third, anti-tired ability; fourth, ability of adapting to time difference; and fifth, mental character.

### 12.3.2 *Military Skill*

Military skill is the “fundamental” to improve the comprehensive quality of military science postgraduate. Good military skill is a comprehensive reflection of mental skills and motor skills. It is one of the core elements that constitute military quality, and it is the fundamental means of combat troops to complete task [3]. Military skills of military science postgraduate include the following two capabilities [4]: first, single-handed skill, and second, collaborative skill.



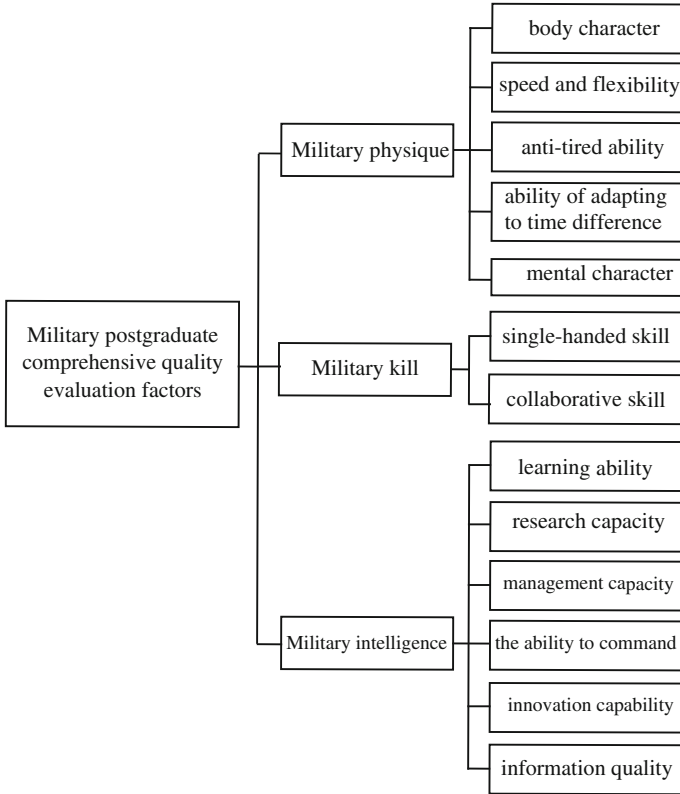


Fig. 12.1 Factor system

### 12.3.3 Military Intelligence

Military intelligence is the “drive” to improve the comprehensive quality of military science postgraduate. Military intelligence indicates the degree of innovation in the implementation of tasks. It is a complex which composed of multi-factor and multi-sequence by the military knowledge, intelligence, and abilities [5]. Only advanced intelligent cultivation, especially in favor of military weapons and equipment research and development of military intelligence, can greatly promote the pace of construction troops. Military intelligences of military science postgraduate include the following six capabilities: first, learning ability; second, research capacity; third, management capacity; fourth, the ability to command; fifth, innovation capability; and sixth, information quality.

In a lot of discussion and questionnaire survey, the article established the factor system of comprehensive quality evaluation to military science postgraduate [6]. The factor system was shown in Fig. 12.1.

**Table 12.1** Expert weight table

Experts	Factors						$\Sigma$
	$u_1$	$u_2$	...	$u_i$	...	$u_n$	
Expert 1	$a_{11}$	$a_{21}$	...	$a_{i1}$	...	$a_{n1}$	1
Expert 2	$a_{12}$	$a_{22}$	...	$a_{i2}$	...	$a_{n2}$	1
...	...	...	...	...	...	...	...
Expert $k$	$a_{1k}$	$a_{2k}$	...	$a_{ik}$	...	$a_{nk}$	1
Weight $a_i (i = 1, 2, \dots, n)$	$\frac{1}{k} \sum_{j=1}^k a_{1j}$	$\frac{1}{k} \sum_{j=1}^k a_{2j}$	...	$\frac{1}{k} \sum_{j=1}^k a_{ij}$	...	$\frac{1}{k} \sum_{j=1}^k a_{nj}$	1

### 12.4 Weigh System of Evaluation

In order to determine the weigh system of evaluation, the paper used the expert evaluation method. Let us assume factor set as follows [7]:  $U = \{u_1, u_2, \dots, u_n\}$ . Experts' weights respective of each factor are given as shown in Table 12.1.

According to Table 12.1, we can obtain the average weight of each factor.

$$a = \frac{1}{k} \sum_{j=1}^k a_{ij} \quad (i = 1, 2, \dots, n)$$

Weight of each factor:

$$A = \left( \frac{1}{k} \sum_{j=1}^k a_{1j}, \frac{1}{k} \sum_{j=1}^k a_{2j}, \dots, \frac{1}{k} \sum_{j=1}^k a_{nj} \right)$$

If the expert weight of each factor was filled in Table 12.1 we could obtain weight system of military science postgraduate comprehensive quality evaluation as Table 12.2.

### 12.5 Model System of Evaluation

Due to many factors of military science postgraduate comprehensive quality are difficult to quantify, the article used the fuzzy comprehensive evaluation model [7].

**Table 12.2** Weigh system table

Assessment objective	The first level indicators	Weights	The second level indicators	Weights
Military postgraduate comprehensive quality evaluation factors <i>U</i>	Military physique <i>U<sub>1</sub></i>	<i>a<sub>1</sub></i> (0.25)	Body character	<i>a<sub>11</sub></i> (0.25)
			Speed and flexibility	<i>a<sub>12</sub></i> (0.15)
			Anti-tired ability	<i>a<sub>13</sub></i> (0.2)
			Ability of adapting to time difference	<i>a<sub>14</sub></i> (0.15)
			Mental character	<i>a<sub>15</sub></i> (0.25)
	Military kill <i>U<sub>2</sub></i>	<i>a<sub>2</sub></i> (0.30)	Single-handed skill	<i>a<sub>21</sub></i> (0.4)
			Collaborative skill	<i>a<sub>22</sub></i> (0.6)
	Military intelligence <i>U<sub>3</sub></i>	<i>a<sub>3</sub></i> (0.45)	Learning ability	<i>a<sub>31</sub></i> (0.1)
			Research capacity	<i>a<sub>32</sub></i> (0.1)
			Management capacity	<i>a<sub>33</sub></i> (0.2)
			The ability to command	<i>a<sub>34</sub></i> (0.2)
			Innovation capability	<i>a<sub>35</sub></i> (0.25)
			Information quality	<i>a<sub>36</sub></i> (0.15)

### 12.5.1 Establishing the Factor Sets

Factor sets consist of  $U_1$ ,  $U_2$ , and  $U_3$ .  $U = \{U_1, U_2, U_3\}$ . Each element is military physical, military skill, and military intelligence.  $U_1 = \{U_{11}, U_{12}, U_{13}, U_{14}, U_{15}\}$ . Each element is body character, speed and flexibility, anti-tired ability, ability of adapting to time difference, and mental character.  $U_2 = \{U_{21}, U_{22}\}$ . Each element is single-handed skill and collaborative skill.  $U_3 = \{U_{31}, U_{32}, U_{33}, U_{34}, U_{35}, U_{36}\}$ . Each element is learning ability, research capacity, management capacity, the ability to command, innovation capability, and information quality.

### 12.5.2 Establishing the Evaluation Sets

Evaluation sets are usually given by the judgment of experts.  $V = \{V_1, V_2, V_3, V_4, V_5\}$ . Normally, evaluation sets are composed of five levels; they are excellent, good, fair, poor, and bad. Scores were 100, 80, 60, 40, and 20.

### 12.5.3 Comprehensive Evaluation

Experts generally include those personnel of military education, management, researching, decision-making, and so on. The evaluation order was as follow: firstly, evaluating the second-level single factor; secondly, evaluating second-level factors; finally, evaluating first-level evaluation factors.

#### 12.5.3.1 Second-level Single Factor Evaluation

After the expert judgment of each single factor of the second-stage factors, we can get a fuzzy mapping. To  $U_{11}$ , for example, the views of 10 experts: Five experts believe it is excellent, four experts think it is good, and one expert believes it is fair. We can get a fuzzy mapping:

$$U_{11} \mapsto \left( \frac{5}{10}, \frac{4}{10}, \frac{1}{10}, 0, 0 \right) = (0.5, 0.4, 0.1, 0, 0)$$

After similar statistics for each factor, we can get a second-level single factor evaluation matrix:

$$R_1 = \begin{bmatrix} 0.5 & 0.4 & 0.1 & 0 & 0 \\ 0.7 & 0.2 & 0.1 & 0 & 0 \\ 0.8 & 0.2 & 0 & 0 & 0 \\ 0.7 & 0.1 & 0.1 & 0.1 & 0 \\ 0.6 & 0.3 & 0.1 & 0 & 0 \end{bmatrix}$$

Similarly, we can get second-level single factor evaluation of  $U_2$  and  $U_3$ :

$$R_2 = \begin{bmatrix} 0.8 & 0.1 & 0.1 & 0 & 0 \\ 0.9 & 0.1 & 0 & 0 & 0 \end{bmatrix}$$

$$R_3 = \begin{bmatrix} 0.8 & 0.1 & 0.1 & 0 & 0 \\ 0.7 & 0.2 & 0.1 & 0 & 0 \\ 0.9 & 0.1 & 0 & 0 & 0 \\ 0.8 & 0.2 & 0 & 0 & 0 \\ 0.7 & 0.1 & 0.2 & 0 & 0 \\ 0.8 & 0.2 & 0 & 0 & 0 \end{bmatrix}$$

#### 12.5.3.2 Comprehensive Evaluation of Second-level Factors

Assuming the weight of  $U_2$  and  $U_2$ , respectively:

$A_1 = (0.25, 0.15, 0.2, 0.15, 0.25)$ ,  $A_2 = (0.4, 0.6)$ ,  $A_3 = (0.1, 0.1, 0.2, 0.2, 0.25, 0.15)$ , the result can be calculated based on the model “ $M(\cdot, +)$ ”:

$$\begin{aligned}
 A_1 \cdot R_1 &= (0.25, 0.15, 0.2, 0.15, 0.25) \cdot \begin{bmatrix} 0.5 & 0.4 & 0.1 & 0 & 0 \\ 0.7 & 0.2 & 0.1 & 0 & 0 \\ 0.8 & 0.2 & 0 & 0 & 0 \\ 0.7 & 0.1 & 0.1 & 0.1 & 0 \\ 0.6 & 0.3 & 0.1 & 0 & 0 \end{bmatrix} \\
 &= (0.645, 0.26, 0.08, 0.015, 0) \\
 A_2 \cdot R_2 &= (0.4, 0.6) \cdot \begin{bmatrix} 0.8 & 0.1 & 0.1 & 0 & 0 \\ 0.9 & 0.1 & 0 & 0 & 0 \end{bmatrix} = (0.86, 0.1, 0.04, 0, 0)
 \end{aligned}$$

### 12.5.3.3 Comprehensive Evaluation of First-Level Evaluation Factors

Assuming the weight of three factors as A:

$$A = (0.25, 0.3, 0.45)$$

And:

$$R = \begin{bmatrix} A_1 \cdot R_1 \\ A_2 \cdot R_2 \\ A_3 \cdot R_3 \end{bmatrix}$$

So:

$$\begin{aligned}
 A \cdot R &= (a_1, a_2, a_3) \cdot \begin{bmatrix} A_1 \cdot R_1 \\ A_2 \cdot R_2 \\ A_3 \cdot R_3 \end{bmatrix} \\
 A \cdot R &= (0.25, 0.3, 0.45) \cdot \begin{bmatrix} 0.645 & 0.26 & 0.08 & 0.015 & 0 \\ 0.86 & 0.1 & 0.04 & 0 & 0 \\ 0.785 & 0.145 & 0.07 & 0 & 0 \end{bmatrix} \\
 &= (0.7725, 0.16025, 0.0635, 0.0025, 0)
 \end{aligned}$$

Therefore, we can calculate the score of comprehensive quality of military science postgraduate.

$$Z = (0.7725, 0.16025, 0.0635, 0.0025, 0) \begin{bmatrix} 100 \\ 80 \\ 60 \\ 40 \\ 20 \end{bmatrix} = 93.98$$

Thus, we can conclude that the level of comprehensive quality of this military science postgraduate was “excellent”.

## 12.6 Conclusions

Military physical, military skill, and military intelligence are the core of comprehensive quality of military science postgraduate. In order to evaluate comprehensive quality, master current research situation, improve training quality, and promote education reform to military science postgraduate, this paper conducted in-depth research. By using a combination of quantitative and qualitative methods, this paper constructed a factor system, weight system, and the model system of comprehensive quality of military science postgraduate. In this paper, the evaluation method was reasonable and feasible. The research results had some reference meaning to other related research in the field.

## References

1. He W, He X, Deng X (2009) Study under conditions of informatization physical training of military personnel. *Mod Artillery J*
2. Li W, Xu H et al. (2001) Modern war and military physical training [M]. PLA Publishing House 5
3. Ai M, Gu X, Ma W (2012) Grasp skills training unit commanding officer reflections. *J Shenyang Artillery Acad* 5
4. Zhang P Le, Ma H, Han J, Long Y (2011) National defense skills training problems and countermeasures. *J Mil Sci* 6
5. Zhang X (1999) Several military personnel training complex thinking. *PLA Inst Phys Educ* 1
6. Xiao Z (1999) The whole bookies of modern soldier character [M]. Nine Continent Book Publisher, Beijing
7. Ming-zheng X (1995) Measures of modern personnel’s character [M]. College of Language Publisher in Peking, Beijing

# Chapter 13

## Analysis and Study About Military Large Special Vehicle Driver's Attention Characters

Xiang Gao, Jianjun Li, Shuai Mu, Haiwen Zheng, Min Chen  
and Ming Kong

**Abstract** Driver's attention features is a key factor of driving safety, especially for large special military vehicle driver. It is very necessary to analyze the influencing factors and study the stability of its attention, continuity of attention and the intensity of attention. In order to study the drivers' attention characters of large special military vehicle, a test about attention characters in different conditions was made among 36 special vehicle drivers in this paper. By the analysis of the main factors of age, driving age, and time of continuous driving, all kinds of factors on drivers' attention were reflected by using graphs clearly, hoping to provide help for selecting, using, and managing the special vehicle drivers.

**Keywords** Attention characters · Special vehicle · Driver

“Attention” mentally defined as perspicuous consciousness, making the consciousness work, producing perspicuous mental preparation, the sense of some things, and behaviors. Or it is understood plainly as “attention” is the psychological activity's point and focus that is resulted by some condition. Because of this point and focus, the driver can reacted to the path condition from a particular phenomenon clearly. The driver will adapt to the needs of safe driving, which is more important for large special vehicle by putting aside those irrelevant objects [1].

In the process of driving, a main object is the “center of attention”; the rest is in the “edge of attention.” While driving, the “center and edge of attention” is in constant change. That at some point, one is the attention center of state and the rest are on the brink of attention of state; another moment, maybe another state of matter may become attention center; attention to the original center along with most of the state of matter turned out to be attention to the edge. For large special vehicle, the vehicle's characteristics determine its attention center; in the road, it may be more; attention center changes quickly, so the driver's request is higher [2].

---

X. Gao (✉) · J. Li · S. Mu · H. Zheng · M. Chen · M. Kong  
Air Defence Forces Academy, Zhengzhou, China  
e-mail: gaoux7610@126.com

Driver's attention features is a key factor of driving safety, especially for large special military vehicle driver. It is very necessary to analyze the influence factors and study the stability of its attention, continuity of attention and the intensity of attention.

### 13.1 The Influence Factors of Attention

Studies showed that age, gender, driving experience, continuous driving time, thought condition, vehicle driving performance, cabin comfort, and so on related to attention [3]. Considering the force drivers were men, we do not consider gender issues. In addition, the large special military vehicle driving performance and cabin comfort levels were similar, so we also do not consider these two factors. And thought of the volatile driver is an extremely individual phenomenon, so we do not consider either. We mainly analyze the effect of the age, driving experience, and continuous driving time on attention [4].

### 13.2 Attention Test

Currently, focus detection technology mainly includes auditory attention tests based on ear points technology, revised attention testing table aim at visual attention, eye tracking technology apply to the visual attention dynamic determination widely, etc. [5].

Vision is the most important in the sense organs. The capacity of visual information is 250 times more than hearing in the electric physiology measurement to human body. Considering the operational test in the army, we adopt the method of revised attention testing table aiming at visual attention [6].

A check table used to test the driver's attention specially is proposed by American psychologist Dr. Joseph Brock, as shown in Fig. 13.1. While testing, the drivers are asked to find the number from 10 to 59 in the table successively and watch the determination of reading time. After long-term research, Dr. Brock summed the following rules: the drivers', reading time between 10 and 30 s, respond ability is better; and the drivers' reading time more than 1 min was proved that their attention were dispersed.

Teacher Li, Xi'an, Jiaotong University, improved the test method for parallel table test block in the thesis. Each number from 1 to 25 was arranged as far as possible in the parallel table according to principle; we made four tables of 46 cm by 46 cm, as shown in Fig. 13.3a–d. Because the table number is half of the Brock checklist, the drivers are hard to leak. In addition, in order to avoid subjects that are easy to remember several groups of numbers while explanation, result in the first test is not accurate; a table is designed of the same type, for the interpretation and practice (see the Fig. 13.2). The five tables will be posted on the wall while



**Fig. 13.1** Brock test table

34	19	42	54	45
26	16	39	28	57
40	35	14	56	30
12	29	44	51	23
50	43	36	24	11
37	20	55	32	47
25	41	17	35	38
13	22	48	10	58
52	18	21	31	46
27	49	33	15	59

**Fig. 13.2** Explain and practice table

21	12	7	1	20
6	15	17	3	18
19	4	8	25	13
24	2	22	10	5
9	14	11	23	16

testing, which is 1.7 m high away from land; the subjects stand in front of table, 1.7 m, and point out 7–25 in order with a rod. The main subjects record time with a stopwatch [1].

By the tests, we can induct that is good who finishes the first table in 40 s, that is medium whose finish the table in 40–50 s, and that is considered attention speed is slow who finishes it in more than 50 s. The second, the third, and the fourth table reading time represents the attention stability, namely if the reading time is almost the same or gradually shortened, show that the subjects’ attention stability is good [1].

**Fig. 13.3** Parallel test tables. **a–d** are the first table to the fourth table to test driver’s attention

9	5	11	23	20
14	25	17	19	13
3	21	7	16	1
18	12	6	24	4
8	15	10	2	22

5	14	12	23	2
18	25	7	24	13
11	3	20	4	16
5	10	19	22	1
21	15	9	17	8

14	18	7	24	21
22	1	10	9	6
16	5	8	20	11
23	2	25	3	15
19	13	17	12	4

22	25	7	21	11
6	2	10	3	23
17	12	15	5	18
1	16	20	9	24
19	13	4	14	8

### 13.3 Test Results and Analysis

#### 13.3.1 The Test Result Data

In this paper, a total of 36 large special vehicle drivers were tested. All drivers’ age and driving age distribution is shown in Table 13.1.

Test results are shown in Tables 13.2, 13.3, and 13.4.

#### 13.3.2 The Relationship of Attention and Influence Factors

According to the test data form a graph as shown in Figs. 13.4, 13.5, and 13.6.

We can summarize as follows according to the curve above:

- (1) The curve of test time of Fig. 13.3a showed that the average time is extended as the growth of the age of drivers, younger drivers react fast, correspond with the physiological rule, but the time range of older drivers is narrow to

**Table 13.1** The distribution of age and driving experience

Age distribution		Driving experience distribution	
Age	Number of people	Driving experience	Number of people
20–25 years	8	3–5 years	6
25–30 years	15	5–8 years	10
30–35 years	10	8–12 years	15
35 years or older	3	12 years or older	5

**Table 13.2** The driver’s test time on average in different age paragraph

Age	Figure 13.3a	Figure 13.3b	Figure 13.3c	Figure 13.3d
20–25 years	39.546 s	39.478 s	40.326 s	38.125 s
25–30 years	40.143 s	39.457 s	41.207 s	38.285 s
30–35 years	42.206 s	42.341 s	41.874 s	42.388 s
35 years or older	42.715 s	42.025 s	42.357 s	42.796 s

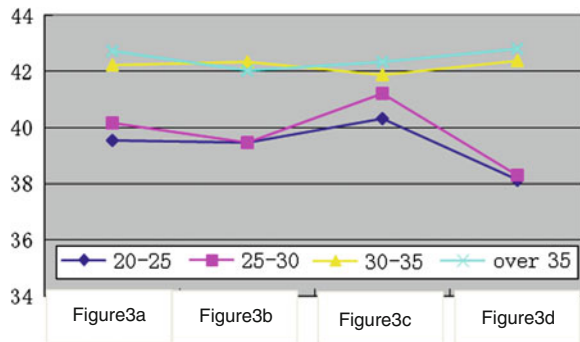
**Table 13.3** The driver’s test time on average in different driving experience

Driving experience	Figure 13.3a	Figure 13.3b	Figure 13.3c	Figure 13.3d
3–5 years	39.412 s	39.521 s	38.197 s	39.167 s
5–8 years	38.975 s	39.126 s	38.296 s	39.287 s
8–12 years	40.127 s	39.861 s	39.786 s	40.391 s
12 years or older	40.598 s	40.254 s	40.690 s	40.427 s

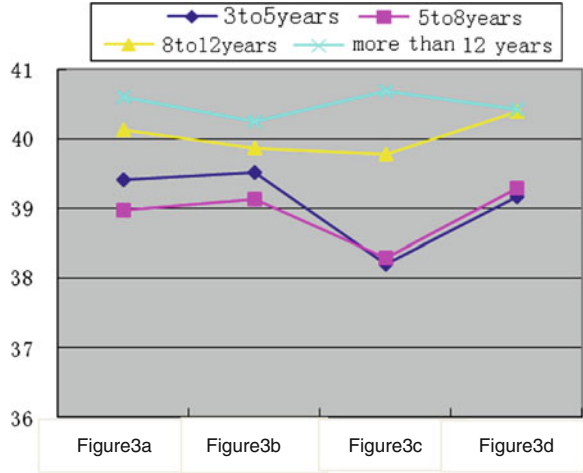
**Table 13.4** All drivers’ test time on average in different continuous driving time

Continuous driving time						
		0 h	1 h	2 h	3 h	4 h
All driver’s test time on average	Figure 13.3a	40.156	40.389	41.092	42.874	44.285
	Figure 13.3b	40.073	40.574	41.173	42.765	43.958
	Figure 13.3c	40.285	40.613	40.925	42.813	44.816
	Figure 13.3d	40.381	40.515	41.132	42.916	44.716

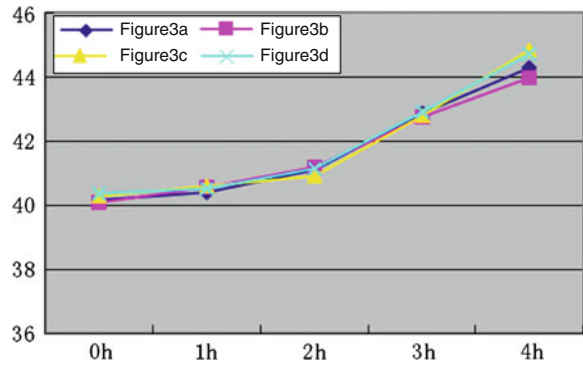
**Fig. 13.4** The relationship of test time and age



**Fig. 13.5** The relationship of test time and driving experience



**Fig. 13.6** The relationship of test time and continuous driving time



finish other three form, and the younger drivers is opposite. The reading time has no significant difference between age curves and driving age, because the longer the driving age is, the bigger the drivers' age will be. It cannot state the driving age and effect of age on drivers' attention features, but can explain the older and the longer driving drivers' attention stability is good.

- (2) When continuous driving time extended, the drivers' reading time extended, which shows that continuous driving time influences attention characteristics more; it is the main factor influencing the drivers' attention characteristics.
- (3) For large special vehicle driver selection, use and management should consider the corresponding several factors, especially to strengthen the control of continuous driving time.

## References

1. Baichuan Li (1996) Analysis and study about the relationship between driver's attention characters and traffic accidents. *Chinese Ergonomics* 6(2):38-41
2. WEI Y, LIU Y (2007) A study of motor vehicle drivers' attention. *J Shandong transp Univ* 15(3):12-14
3. Ting L, Shulan J (2004) A comparison between age-related differences of attention allocation and selective attention. *Psychol Sci* 27(6):1330-1334
4. Shengzhao L, Li W, Xinyu J et al (1995) The application of the measure technique of the distribution of visual attention. *J China Saf Sci* 5(6):7-10
5. Zongqi L, Xiugan Y, We H et al (2006) Quantitative measuring method of pilots' attention allocation. *J Beijing Univ Aeronaut Astronaut* 32(5):519-539
6. Jinhua C, Kan C (2006) Reliability mathematics introduction. Higher Education Press, Beijing, pp 182-244

# Chapter 14

## Experimental Study on 5-km Armed Cross-Country Based on Heart Rate Data Analysis

Honglei Li, Zhibing Pang, Meng Kang, Xiaogao Wang, Shuai Mu, Miaofei Chen, Haitao Zhao, Hongyan Ou, Ming Kong and Min Chen

**Abstract** The requirement for soldiers' load-carrying capacity is not reduced, but gradually increased as future battle conditions are getting more complicated, weapons and equipment are day by day improved. 5-km armed cross-country is one of the main contents of army physical training. If compared with free cross-country, there exist both similarities and differences between them. In this experiment, comparative study of full heart rate monitoring versus training result based on 3 groups of data is introduced, so as to find out the laws and characteristics and lay a scientific basis for 5-km armed cross-country training management in terms of teaching and training in military academies and field troops.

**Keywords** Heart rate data analysis · 5-km armed cross-country · Experimental study

### 14.1 Introduction

5-km armed cross-country is one of the main contents of army physical training, which is usually conducted in the field either by individual or in groups with weapons and equipment. It is employed on purpose to develop and improve the capabilities of fast mobility. Studies are of great significance to improve training efficiency, get adapted with various complex environment, enhance soldiers' physical conditions, and combat efficiency [1].

---

H. Li (✉) · Z. Pang · M. Kang · X. Wang · S. Mu · M. Chen · H. Zhao · H. Ou · M. Kong · M. Chen  
Air Defense Forces Academy, Zhengzhou 450052, China  
e-mail: fkb\_mmes@163.com

## **14.2 Heart Rate Analysis Experiment on 5-km Armed Cross-Country**

### ***14.2.1 Experiment Design***

Each testee needs to go through 3 tests: free 5-km cross-country (abbreviated as first testing), 5-km armed cross-country for the first time (abbreviated as second testing), and 5-km armed cross-country for the second time after being trained for 2 months (abbreviated as third testing). Testing result and heart rate data are recorded in each test and then carry out study on the laws and methods of 5-km armed cross-country training with scientific approaches.

### ***14.2.2 Experiment Object***

40 male academy cadets. Average age: 22. Average height: 172 cm. Average weight: 68 kg. Blood pressure, heart rate, and other physical qualities good. All objects are psychologically tested normal by Cattell-16PF.

### ***14.2.3 Experiment Preparation***

Standard 5-km armed cross-country equipment is adopted for testees:

Camouflage (BDU), waist belt and rubber shoes; 1 automatic rifle, 1 gas mask, 1 canteen (full of water), 1 grenade pouch (containing dummy grenade 4 pcs), 1 bandoleer (containing vacant magazine 4 pcs), and 1 shoulder bag (containing toiletries) [2]; Modified Cattell-16PF testing software, 8 stop watches, and 1 heart rate remote monitor; standard sports field of open view and good illumination.

### ***14.2.4 Experiment Method***

This experiment is carried out in 3 stages. Preparation: conducting ideological education for testees to be fully aware of the proceedings and significance of the experiment. Implementation: conducting 3 tests on experiment objects as was designed. Data collection and analysis: collecting all data obtained in the previous two stages and analyze them with software and reach relevant conclusions.

## 14.3 Data Processing

Statistically process the collected data and obtain classified charts as follows. Chart 1 shows the heart rate curve of testees who have completed all 3 tests, chart 2 shows the heart rate curve of testees who have passed the third test, chart 3 shows the heart rate curve of testees who have passed the third test but failed the second test.

## 14.4 Analysis and Discussion

### 14.4.1 Experiment Analysis

Analysis of Fig. 14.1: first, 21 testees that have passed all three tests significantly improved their performances as training increases; second, 1 ~ 3 min is the sharply increasing stage of heart rate, 3 ~ 12 min is the slowly increasing stage of heart rate, 12 ~ 20 min is the sustaining stage, and 20 ~ 20 + minute is the slowly decreasing stage; third, most testees distributed their strength unreasonably in the second testing: running out of strength after 10 min due to premature push-up in 1 ~ 3 min; fourth, testees are able to distribute their strength reasonably and greatly improve their performances after special training.

Analysis of Fig. 14.2: first, duration of the heart rate sustaining stage in the third testing is noticeably increased among the 20 testees that have passed the third testing; second, number of testees that are able to sprint at the finish is noticeably increased if compared with that in the second testing.

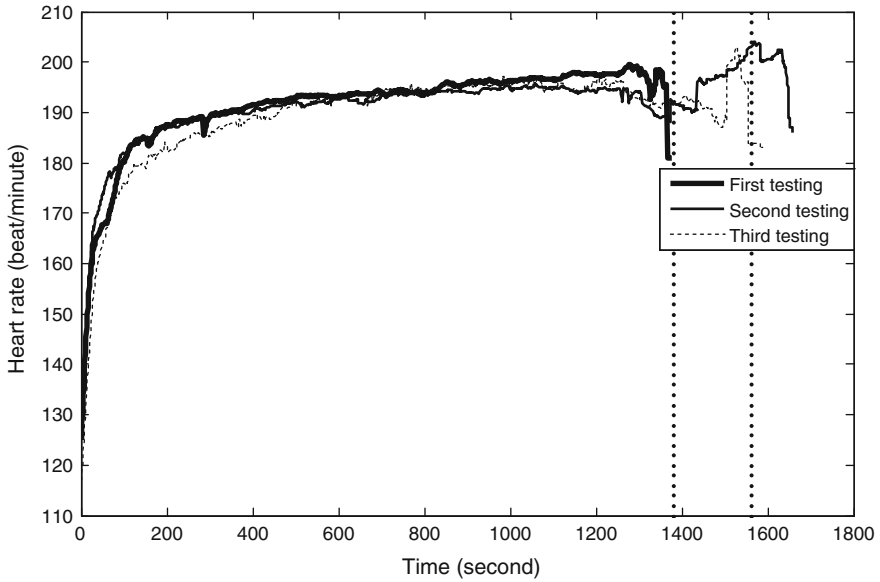
Analysis of Fig. 14.3: 8 testees who failed the second testing but passed the third have noticeably improved their tempo-manipulating capability. Compared with their performance in the second testing, they spent nearly 10 min to increase their heart rate to 190, then adjusted their tempo and decreased their heart rate to 185, and finally sprinted for almost 1 min.

### 14.4.2 Discussion

#### 14.4.2.1 Making Overall Plans Scientifically for Training Management

Make overall plans of 5-km armed cross-country training, arrange training contents from easy to difficult step by step, and manage training scientifically and systematically. Conduct education of general knowledge and make reasonable training plan, mix the strong with the weak to bring along them and cultivate team spirit, conduct reinforced training to improve the overall combat efficiency.



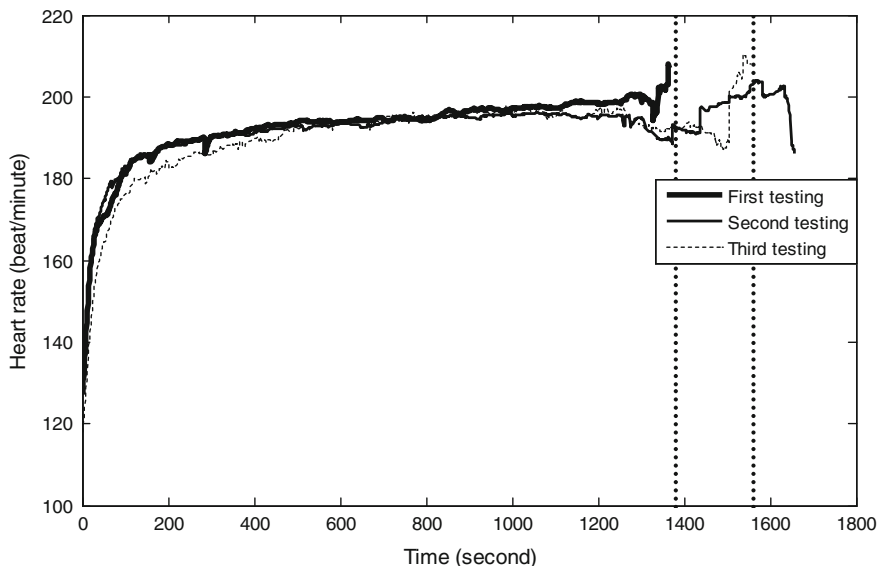


Testing	Average result	Number of testees
First	21'58"	21
Second	25'24"	21
Third	24'56"	21

Fig. 14.1 Heart rate curve of testees who have completed all 3 tests

#### 14.4.2.2 Implement Training Strictly While Following Principles and Laws

Attach importance to researching the principles and laws of 5-km armed cross-country training. Attention should be paid to these 4 points: first, combining aerobic endurance exercise and anaerobic endurance exercise but giving priority to aerobic exercises [3]; second, integrating strength exercises for upper limbs, lower limbs and torso as 5-km armed cross-country training is not merely an exercise for endurance; third, emphasizing both strength and speed as they both are crucial physical qualities for 5-km armed cross-country; fourth, incorporating load-carrying games into 5-km armed cross-country training so as to on the one hand make the dull training interesting and on the other hand improve the agility and flexibility of cadets [4].

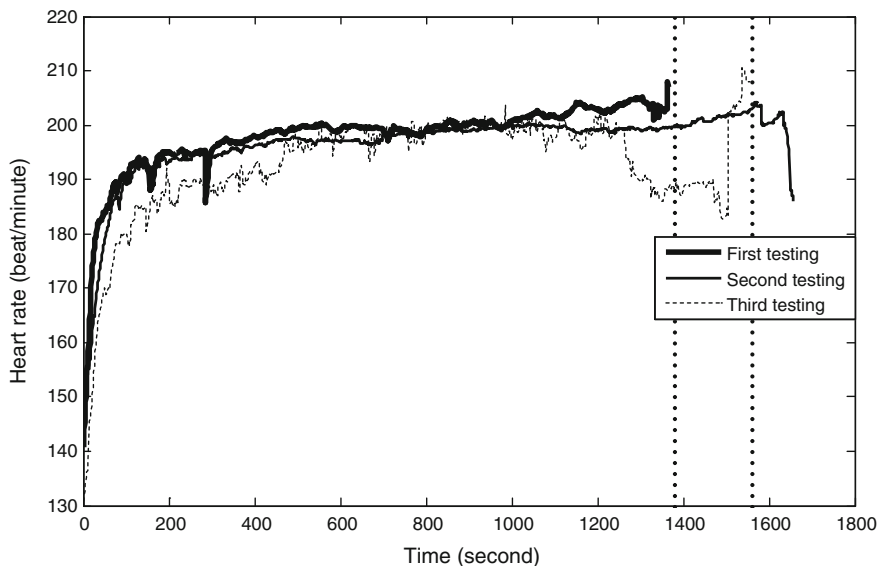


Testing	Average result	Number of testees
First	21'55"	20
Second	25'24"	20
Third	24'49"	20

Fig. 14.2 Heart rate curve of testees who have passed the third test

### 14.4.2.3 Making Full Preparations Scientifically

Full preparation is the precondition to improve training efficiency. The first is mental preparation. Encourage trainees to challenge their physical and psychological limits at 1.5 ~ 3 km and devote themselves into the 5-km armed cross-country training with high spirits. The second is equipment preparation. Make sure the equipment is reasonable or not, and make sure the equipment is neither too slack nor too tight lest it hurt the trainees during training. The third is warm-up preparation. Don't start 5-km armed cross-country before a 2 ~ 3 km warm-up jogging and medium-level arthrosis activities. Stretch their ligament and muscle to improve their adaptive capabilities and reduce the probability of training accidents [5]. The fourth is necessary medical preparation. Medical workers, first-aid medicine, and instrument as well as ambulance vehicle should be in place before hand.



Testing	Average result	Number of testees
First	22'18"	8
Second	26'50"	8
Third	25'18"	8

Fig. 14.3 Heart rate curve of testees who have had passed the third test but failed the second test

#### 14.4.2.4 Distributing Strength Smartly

Trainees should be guided to distribute their strength reasonably in the following ways. First, constant-speed running, namely, to maintain a constant speed from start to finish. It is suitable for trainees of good endurance but poor ability to sprint. Second, variable speed running. It consumes strength greatly and is therefore suitable for trainees of good endurance and acceleration. Third, taking the lead in running. It is suitable for trainees of good performance but the distance between them and others should be maintained reasonably lest those falling behind be bear heavy pressure and the overall performance is adversely influenced. Fourth, slipstream running, namely, to select another trainee in the front and run after him. It is suitable for trainees of poor comprehensive qualities [6].

#### **14.4.2.5 Paying Attention to After-Training Adjustment and Relaxation**

Trainees are extremely fatigued both physically and psychologically after 5-km armed cross-country training. Having ache, numbness or pain in torso and limbs is natural. More seriously they may even suffer from shock or faint. Trainees should walk or jog other than stop to sit or lie down. Organize men to mutually relax themselves by stroking, kneading, and shaking or to complement energy by taking in glucose to regain strength [7].

### **14.5 Conclusion**

The 5-km armed cross-country experiment data study provides the basis for scientifically organizing 5-km armed cross-country training and noticeably improve the exercise result and training quality. Analysis on other physical factors and individual differences is to be further carried out so as to reach a whole set of solutions and measures.

### **References**

1. Deng T (2006) Problems and solutions in armed cross-country training. Chinese Special Police
2. Army Military Training and Assessment Outline (2008) PLA Press, Beijing
3. Siqin W (2004) Study on the relations between double anoxia training and 5 km armed cross-country capabilities. J PLA Phys Edu Acad
4. Wang W (2009) Research on systematic teaching of 5 km armed cross-country. J Mil PE Further Edu Acad
5. Mu S (2013) Research of five-kilometer armed off-road training teaching experiment. In: Proceedings of the 13th international conference on man-machine-environment system engineering, 2013.10
6. Kong M (2013) Research of five-kilometer armed off-road training methods. In: Proceedings of the 13th international conference on man-machine-environment system engineering, 2013.10
7. Chen M (2013) Comparative analysis on the performance of different students in five-kilometer armed off-road running. In: Proceedings of the 13th international conference on man-machine-environment system engineering, 2013.10

# Chapter 15

## Exploring the Psychophysical Relationship Between Basic Fabric Construction Parameters and Typical Tactile Sensations

Ruitao Jiang, Jiyong Hu, Yuan Zhang and Xin Ding

**Abstract** The psychophysical relationship between fabric construction parameters and tactile sensations remains unknown, and it limits the development of textile products as well as their virtual rendering techniques. To uncover the underlying psychophysical relationship, this study designed a series of plain woven fabrics, and two basic construction parameters, i.e., weft yarn density and weft yarn diameter, gradually change. Meanwhile, the typical tactile sensations of these fabrics are evaluated by the magnitude estimation method and the paired comparison method. By applying the classical psychometric analysis to the sensation evaluation data, the discrimination threshold and the Weber fraction are calculated, respectively. From psychometric analysis, both perceived roughness and softness sensation decreased with an increase of weft density and weft yarn diameter. The Weber fraction for weft density is 0.16 in roughness and 0.21 in softness, for yarn diameter 0.3 in roughness and 0.26 in softness, respectively.

**Keywords** Yarn density · Yarn diameter · Roughness · Softness · Weber fraction

### 15.1 Introduction

The tactile quality of fabrics is a key parameter in successful textile marketing strategies. Meanwhile, with the development of the virtual rendering technology of fabric tactile textures, it needs to know the psychophysical characteristics of fabric tactile perception with respect to fabric properties, which is determined by the fiber and yarn properties, basic construction parameters, and finishing techniques. Several researchers have studied the effect of process parameters on the fabrics tactile quality. Winakor et al. [1] asserted that tactile feeling is affected by material type.

---

R. Jiang · J. Hu (✉) · Y. Zhang · X. Ding  
College of Textile, Donghua University, Shanghai 201620, People's Republic of China  
e-mail: huji@dhu.edu.cn

Cotton, wool, acrylic, and polyester fabrics with the similar yarn linear densities and constructions were clearly differentiated on several sensory attributes. Other investigations have shown that the tactile quality of fabric is influenced by yarns properties, such as type [2, 3] (single or folded), production process (ring-traveler or open-end, combed or carded) [3, 4], count, and twist. Furthermore, it has been also observed that weave and knit construction [5] and fabric density [3, 6] affected the tactile feeling of fabrics. Some studies have investigated the influence of finishing treatments on tactile properties of fabrics. The effects of softening [7], bio-polishing [8], and calendaring [9] on the sensory properties of woven fabrics have been studied. However, the mechanism that the psychophysical characteristics of fabric tactile perception were affected by the basic fabric construction parameters is still unknown. Actually, fabric construction parameters such as weft density and weft yarn diameter determined the geometrical morphology and distribution characteristics of surface texture. This paper designed two sets of plain woven fabrics and two basic construction parameters, i.e., weft yarn density and weft yarn diameter to explore the psychophysical relationship between basic fabric construction parameters and typical tactile sensations by the methods of magnitude estimation and paired comparison.

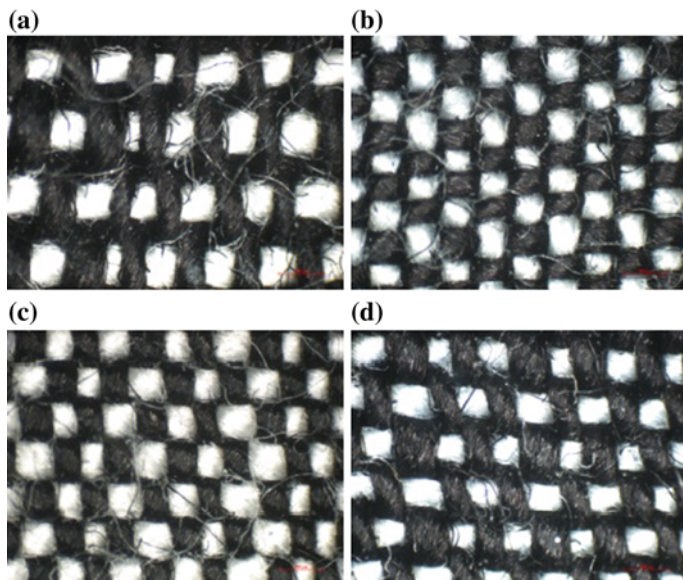
## 15.2 Materials and Methods

### 15.2.1 Materials

In this study, the fabrics were industrially produced by means of LT102-type rapier loom. The following weaving parameters, i.e., material (100 % siro-spinning cotton), the weft density (16–24 weft yarns per cm) and the weft yarn diameter (210–305  $\mu\text{m}$ ), have varied as shown in Table 15.1. The stereoscopic microscope images of fabrics are shown in Fig. 15.1.

**Table 15.1** Structural parameters of woven fabric

Group	Fabric number	Fabric weave	Weft density (weft yarn/cm)	Count ( $N_m$ )	Diameter ( $\mu\text{m}$ )
First	1	Plain	28 $\times$ 16	27 $\times$ 27	240
	2	Plain	28 $\times$ 18	27 $\times$ 27	240
	3	Plain	28 $\times$ 20	27 $\times$ 27	240
	4	Plain	28 $\times$ 22	27 $\times$ 27	240
	5	Plain	28 $\times$ 24	27 $\times$ 27	240
Second	6	Plain	28 $\times$ 24	27 $\times$ 17	305
	7	Plain	28 $\times$ 24	27 $\times$ 21	278
	8	Plain	28 $\times$ 24	27 $\times$ 24	258
	9	Plain	28 $\times$ 24	27 $\times$ 27	240
	10	Plain	28 $\times$ 24	27 $\times$ 36	210



**Fig. 15.1** The 20 times image of fabrics **a** is the first fabric, **b** is the fifth fabric, **c** is the sixth fabric, and **d** is the tenth fabric

### 15.2.2 Sensory Evaluation

Before instrumental and sensory evaluation, the samples were precut into  $20 \times 20$  cm squares. The tests were performed in standard atmosphere ( $20 \pm 2^\circ\text{C}$  and  $65 \pm 5\%$  relative humidity). The fabrics were preconditioned for 24 h before evaluation.

To evaluate the typical tactile sensations of produced fabrics, the sensory evaluation method that refers to AATCC: Guidelines for the Subjective: Evaluation of Fabric Hand and GBT 19547-2004 Sensory Analysis Methodology Magnitude estimation has been used. The trained participants (6 men, 12 women, aged from 18 to 24) were recruited; most of them were textile background. The evaluation has been performed in blind condition and replicated thrice. Participants were asked to assess the roughness and softness by using both magnitude estimation method and paired comparison method. For magnitude estimation method, the roughness and softness of each fabric were scored on the basis of a reference fabric with defined score equal to 50. For paired comparison method, participants determined the rougher or softer fabric (left or right).

### 15.2.3 Research Method

This paper is based on the methods of magnitude estimation and paired comparison in sensory evaluation to explore the psychological physical properties of fabrics. A multivariate analysis of variance was computed in order to test the validity of experiment (significance level of 5 %). With the same weft density and weft yarn diameter, there were no significant difference on the roughness sensation ( $p=0.85$ ,  $p=0.77$ ) in these three repeatable experiments. The same results were obtained from three repeatable experiments of softness sensation ( $p=0.59$ ,  $p=0.9$ ); it can be concluded that the data of three repeatable experiments came from the same sample. At the same time, in order to avoid each assessor's score, coordinate system is different; the data of experiment were normalized. Meanwhile, we take Grubbs tests to reject the abnormal value in order to avoid assessors were affected by accidental factors in subjective experiment such as fatigue etc. The discrimination threshold of roughness and softness sensations that affected by weft density and weft yarn diameter, respectively, were calculated by constant stimulus method. So the Weber fraction is

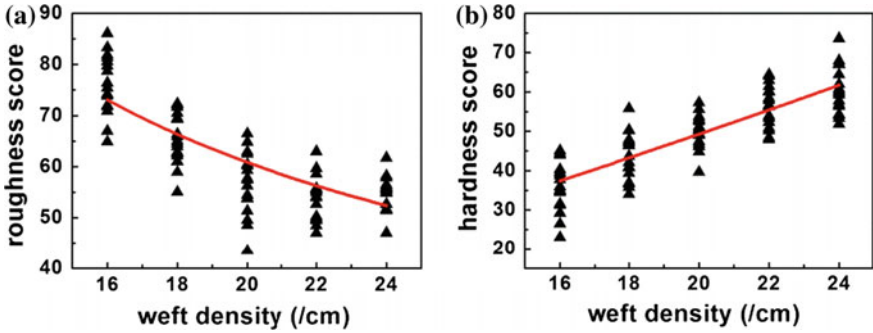
$$K = \frac{\sum_{i=1}^5 \frac{\Delta\phi}{\phi}}{5}$$

## 15.3 Results and Discussion

### 15.3.1 Weft Yarn Density Effect

The perceived roughness decreases with the increasing weft yarn density as shown in Fig. 15.2a. This result can be attributed to increased contact area and the number of yarn intersection point in per unit area. As the weft yarn density increases, more materials are filled in the gaps so we get more uniform stimuli when touching the fabric. According to Weber et al. [10], roughness sensation decreased with the figure getting uniform stimuli. Therefore, the perceived roughness decreases with the increasing weft density. The perceived hardness increases with the increasing weft yarn density as shown in Fig. 15.2b. Bergmann Tiest [11] found that softness is related to deformation. When the weft density is increased, the fabric samples are not easy with deformation and stress resistance increases so the hardness sensation increases.

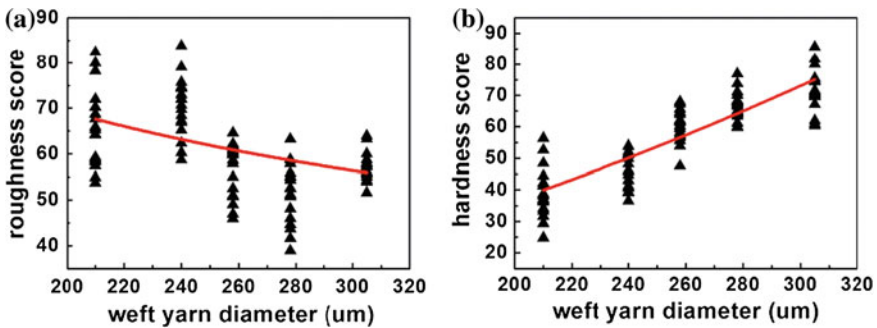




**Fig. 15.2** Effect of weft density on sensory evaluation **a** weft density and roughness sensation **b** weft density and hardness sensation

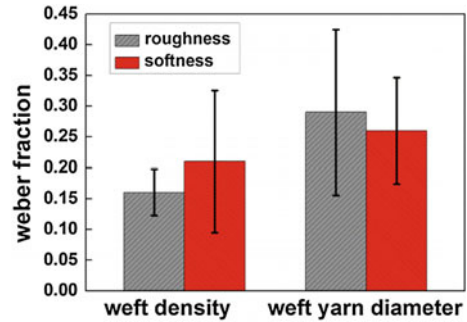
### 15.3.2 Weft Yarn Diameter Effect

The roughness sensation is illustrated in Fig. 15.3a, which decreases with the increasing weft yarn diameter. This result can be attributed to increased contact area and intersection area. Thicker yarn provides increased contact area between sliding surfaces in comparison with finer yarn under the condition that yarn densities of fabrics are same in a unit area. Fabrics constructed with thicker yarns yield more uniform surface than finer yarns since intersection points of yarns causing the distance between two adjacent yarns are smaller. Hardness sensation measurement results of weft yarn fineness, presented in Fig. 15.3b, show parallel behavior in the matter mentioned above of weft yarn density. Fabrics constructed with finer yarns yield smoother surface than thicker yarns. Hu et al. [12] asserted that softness was depended on the relative elastic modulus of fabrics to finger pad. With the increased weft yarn diameter, stress resistance of fabric samples becomes bigger so the perceived hardness increased.



**Fig. 15.3** Effect of weft yarn diameter on sensory evaluation **a** weft yarn diameter and roughness sensation **b** weft yarn diameter and hardness sensation

**Fig. 15.4** The Weber fractions of different structure parameters



### 15.3.3 Weber Fraction

We can calculate the mean of Weber fraction by 75 % difference threshold. All other construction variables (warp yarn density and warp yarn diameter, pattern) are kept constant, only weft yarn density and yarn diameter varied, the Weber fraction for weft yarn density is 0.16 in roughness and 0.21 in softness, for yarn diameter 0.3 in roughness and 0.26 in softness, respectively.

The Weber fractions of typical tactile sensations are shown in Fig. 15.4. For weft yarn density, the Weber fraction of roughness sensation is less than that of softness which means people can easily sense the difference of roughness when we add a slightly smaller amount at the same weft density condition. When weft yarn diameter varies, Weber fraction of roughness sensation is larger than that of softness sensation and the Weber fractions of roughness and softness sensations are both larger than the Weber fractions of weft density which indicates the variation of weft yarn density can easily cause the discrimination of roughness sensation and softness sensation.

## 15.4 Conclusions

In this article, the psychophysical relationship between basic fabric construction parameters and typical tactile sensations was discussed by the sensory analysis method. The obtained results show that the varied weft yarn density and weft yarn diameter have a significant effect on the tactile sensory, the perceptions of roughness and softness decrease with an increase of weft yarn density and yarn diameter. Furthermore, the Weber fraction for weft density is 0.16 in roughness and 0.21 in softness, for yarn diameter 0.3 in roughness and 0.26 in softness, respectively. Obviously, weft yarn density and yarn diameter as two major construction parameters are able to tell the tendency of fabrics' roughness and softness in sensory evaluation. Textile industries could develop products in a method of adjusting process parameters with the guidance of Weber fraction.

**Acknowledgments** This work was supported by the National Natural Science Foundation through project (No. 51175076, No. 11232005), the Natural Science Foundation of Shanghai through project (No. 12ZR1400500), and Chinese Universities Scientific Fund.

## References

1. Winakor G, Kim CJ, Wolins L (1980) Fabric hand: tactile sensory assessment. *Text Res J* 50(10):601–610
2. Behery MH (2005) Effect of mechanical and physical properties on fabric hand. Woodhead Publishing in Textiles, Cambridge
3. Sahnoun M (2002) Caractérisation et modélisation de l'influence des paramètres de structure des étoffes sur l'évaluation mécanique et sensorielle de leur toucher [Phd thesis]: Université de Mulhouse
4. Chattopadhyay R, Banerjee S (1996) The frictional behaviour of ring-, rotor-, and friction-spun yarn. *J Text Inst* 87(1):59–67
5. Bensaid S, Osselin JF, Schacher L, Adolphe D (2006) The effect of pattern construction on the tactile feeling evaluated through sensory analysis. *J Text Inst* 97(2):137–145
6. Choi M-S, Ashdown SP (2000) Effect of changes in knit structure and density on the mechanical and hand properties of weft-knitted fabrics for outerwear. *Text Res J* 70(12):1033–1045
7. Philippe F, Schacher L, Adolphe DC, Dacremont C (2004) Tactile feeling: sensory analysis applied to textile goods. *Text Res J* 74(12):1066–1072
8. Cavaco-Pauio A, Almeida L, Bishop D (1996) Cellulase activities and finishing effects. *Text Chemist Colorist* 28(6):28–32
9. Bueno MA, Viallier P, Durand B, Renner M, Lamy B (1997) Instrumental measurement and macroscopical study of sanding and raising. *Text Res J* 67(11):779–787
10. Weber AI, Saal HP, Lieber JD, Cheng JW, Manfredi LR, Dammann JF et al (2013) Spatial and temporal codes mediate the tactile perception of natural textures. *Proc Natl Acad Sci* 110(42):17107–17112
11. Bergmann Tiest WM (2010) Tactual perception of material properties. *Vision Res* 50(24):2775–2782
12. Hu J, Zhao Q, Jiang R, Wang R, Ding X (2013) Responses of cutaneous mechanoreceptors within fingerpad to stimulus information for tactile softness sensation of materials. *Cogn Neurodyn* 7(5):441–447

# Chapter 16

## The Body Mass Index of Taikonaut Candidates

Xiaochao Guo, Duanqin Xiong, Yanyan Wang, Chunmei Gui,  
Guowei Shi, Jian Du and Yu Bai

**Abstract** All of taikonaut candidates came from China Air Force pilots aged 25–35 in years. The GJB4856-2003 gave the anthropometric data of weight (body mass) and height (stature) for 587 male fighter pilots in this age range investigated in 2001. The weight and height were measured for 1,225 male fighter pilots aged 25–47 in 2013, of which there were 787 pilots in age of 25–35. The BMI was  $23.00 \pm 2.23$  for the taikonaut candidates in 2001 with 31.18 % overweight, and  $24.27 \pm 2.16$  for the candidates in 2013 with 47.14 % overweight. The analysis found that the new candidates possess a comparatively higher value for average BMI, and their overweight trends show an obvious rise with time and age.

**Keywords** Body mass index (BMI) · Overweight · Taikonaut · Male pilots

### 16.1 Introduction

The Body Mass Index (BMI) is defined as the weight in kilograms divided by the height (stature) in meters squared ( $\text{kg}/\text{m}^2$ ) used measure for fatness. The normal range for adults is 18.5–24.9 in WHO classification, but the overweight is with  $\text{BMI} \geq 24.0$  and the obesity is with  $\text{BMI} \geq 28.0$  for Chinese adults [1].

NASA found that the BMI for the astronaut group show a small increase in mean from 23.3 to 24.7 in 3 years [2], their overweight trends show a rapid rise that may result in prevalence similar to that of the general population [3]. FAA has announced that all overweight pilots, controllers must be tested for sleep disorders by calculating the BMI [4]. In China, all of taikonaut candidates came from Air

---

X. Guo (✉) · D. Xiong · Y. Wang · C. Gui · G. Shi · J. Du · Y. Bai  
Institute of Aviation Medicine PLAAF, Beijing 100142, China  
e-mail: guoxiaochao1965@163.com

Force pilots aged 25–35 years according to GJB4016-2000 [5]. The BMI for taikonaut candidates were analyzed based on comparison between pilot groups investigated in 2013 and the pilots in GJB4856-2003 [6] investigated in 2001 to understand their overweight trends.

## 16.2 Method

### 16.2.1 Measurements

The weight (body mass) was measured in kilograms with precision of 0.5 kg, and the height (stature) in meters with precision of 1.0 mm. The BMI was calculated by dividing the weight by the height squared.

### 16.2.2 Samples

There were 587 taikonaut candidates with year-age  $29.50 \pm 3.42$  in 2001 and 787 candidates aged  $29.71 \pm 3.05$  in 2013 with range of 25–35 years.

There were also 393 male pilots whose age was  $42.27 \pm 3.25$  with range of 37–47 years in 2013. So the whole sample was 1,225 aged 25–47 in 2013.

## 16.3 Results

For the candidates in 2001, their BMI were  $23.00 \pm 2.23$  kg/m<sup>2</sup> with 22.05–24.07 in age groups. For the candidates in 2013, their BMI were  $24.27 \pm 2.16$  kg/m<sup>2</sup> with 23.34–25.23 in same age groups.

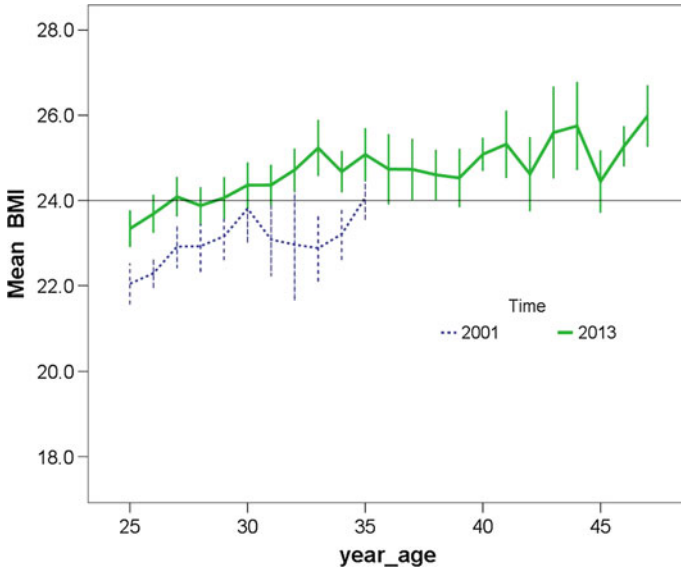
For the elder pilots in 2013 aged 37–47, their BMI were  $24.98 \pm 2.12$  kg/m<sup>2</sup> with 24.44–25.99 in different age groups.

The overweight trends of taikonaut candidates are showed in Fig. 16.1.

## 16.4 Discussions

### 16.4.1 The BMI Between Taikonaut Candidates in 2013 and 2001

The difference was significant in statistics between the mean BMI for the candidates in 2013 and those in 2001 ( $F(1,1373) = 113.29$ ,  $P < 0.001$ ). The new



**Fig. 16.1** The overweight trends for taikonaut candidates

taikonaut candidates in 2013 possess a comparatively higher value for average BMI compared to those in 2001, which the finding is approximately same as the result by NASA [7], but the average BMI of  $24.27 \text{ kg/m}^2$  does exceed the Chinese normal range ( $t = 3.45$ ,  $P < 0.01$ ) that means overweight.

#### ***16.4.2 The BMI Between Elder Pilots in 2013 and Candidates in 2001***

The difference was statistically significant between the mean BMI for the candidates in 2001 and the elder pilots in 2013 ( $F(1,979) = 193.79$ ,  $P < 0.001$ ). And it is demonstrated that the mean BMI was larger than 24.0 by one sample test for the elder pilots ( $t = 9.14$ ,  $P < 0.001$ ). It suggested that the taikonaut candidates in 2001 have growth from the normal BMI value to the overweight after 12 years as a special professional population.

#### ***16.4.3 The Overweight Trends for Taikonaut Candidates***

The overweight and obesity in two taikonaut candidate populations were listed in Table 16.1.

**Table 16.1** The overweight and obesity in two taikonaut candidate populations

Samples		Underweight (BMI < 18.5)	Normal (18.5 ≤ BMI < 24)	Overweight (24.0 ≤ BMI < 28.0)	Obesity (BMI ≥ 28.0)	Total
The candidates in 2001	n	5	389	183	10	587
	%	0.85	66.27	31.18	1.70	100.00
The candidates in 2013	n	0	370	371	46	787
	%	0.00	47.01	47.14	5.84	100.00

The analysis found that the distributions of BMI in Table 16.1 were significantly different between the candidates in 2001 and those in 2013 ( $\chi^2 = 64.68$ ,  $P < 0.001$ ), and there were more overweight candidates in 2013 than the ones in 2001.

As showed in Fig. 16.1, the regression analysis found that the linear equations are  $BMI = 0.1644 * Age + 19.38$  for the taikonaut candidates in 2013 ( $R^2 = 0.88$ ) and  $BMI = 0.1216 * Age + 19.38$  for the candidates in 2001 ( $R^2 = 0.51$ ). It suggested that the overweight trends for the candidates in 2013 show a rapid rise in comparison with that for the candidates in 2001 though they had same BMI value at start point. The finding is approximately same as the result by NASA [3].

## 16.5 Conclusions

The BMI for the taikonaut candidates in 2013 was  $24.27 \pm 2.16 \text{ kg/m}^2$ , which changed in the equation  $BMI = 0.1644 * Age + 19.38$ . It is suggested that the new taikonaut candidates possess a comparatively higher value for average BMI, and their overweight trends show an obvious rise with time and age compared to the BMI for the candidates in 2001.

## References

1. National Health and Family Planning Commission of PRC (2014) The management approach for nutritional improvements. Aug 3 2010. From. <http://www.nhfp.gov.cn/zhuzhan/wsbmgz/201304/2d99c4ebe95047d28079d511e7582960.shtml>, 8 Apr 2014
2. NASA (1995) Update on body mass index. In: Longitudinal study of astronaut health newsletter 4(1):2
3. Baby D (2004) Overweight and obesity in the LSAH population. Longitudinal Study Astronaut Health Newslett 13(1):3–4
4. Fred T (2013) New obstructive sleep apnea policy. FAA Fed Air Surgeon's Med Bull 51(4):2
5. GJB4016-2000 (2000) Medical standard for selecting astronauts. Military standard Publishing House of the General Armament Department, Beijing
6. GJB 4856-2003 (2003) Human dimensions of Chinese male pilot population. Military standard Publishing House of the General Armament Department, Beijing
7. NASA (2000) The 2000 astronaut class. In: Longitudinal study of astronaut health newsletter 9(2):1



# Chapter 17

## Human Dimensions of Chinese Male Pilots in Sitting Posture and Some Changes

Xiaochao Guo, Duanqin Xiong, Yanyan Wang, Guowei Shi, Chunmei Gui, Wei Zheng and Qingfeng Liu

**Abstract** The GJB4856-2003 in effect is based on the latest anthropometric investigations in large scale for Chinese male pilots. There were 22 basic human body measurements of anthropometry in sitting posture. The data of human dimensions were from 1,739 male pilots, including the mean, std. deviation, and 5th, 50th, and 95th percentiles. The analyses suggested that the data of GJB4856 are steady and reliable with good precision. Some human dimensions in GJB4856 seemed to augment generally in comparison with that of GJB20-1984.

**Keywords** Pilots · Human dimensions · Anthropometry · Sitting posture

### 17.1 Introduction

The human dimensions of pilot are fundamental to product design such as cockpit geometrical layout, eject seat and exit, and personal protective equipment. There were three anthropometric investigations in large scale for Chinese male pilots in 1954, 1977, and 2001. The statistical data of the 3rd investigation were presented in GJB4856-2003 [1], while the data of the 2nd investigation were attached to GJB20-1984 [2]. Human body measurements of anthropometry were divided into fundamental items and recommended items according to the frequency of usage in production design for pilots in GJB4856. The fundamental items should have better degree of precision than the recommended items.

The human dimensions in sitting posture in GJB4856 were analyzed in order to compare the data quality and changes of the latest anthropometric investigation with the former data in GJB20.

---

X. Guo (✉) · D. Xiong · Y. Wang · G. Shi · C. Gui · W. Zheng · Q. Liu  
Institute of Aviation Medicine PLAAF, Beijing 100142, China  
e-mail: guoxiaochao1965@163.com

## 17.2 Method

### 17.2.1 Measurement Items and Pilot Sample

There were 22 fundamental items and 17 recommended items of anthropometry in sitting posture in GJB4856. All data were collected by direct measurement with instrument precision of 1.0 mm.

The participants included 1,739 male pilots whose age was  $32.4 \pm 6.8$  in year and body mass (weight) was  $68.8 \pm 8.5$  kg.

### 17.2.2 Database and Quality Control

The database was developed for data records and analysis. Quality management was taken on the spot during all the anthropometric investigation [3].

The standard error of the 50th percentile was less than 2 % in expectation.

## 17.3 Results

The data of 22 fundamental items in sitting posture in GJB4856 were present in Table 17.1. The mean ( $\bar{x}$ ), std. deviation( $s$ ), and the 5th, 50th, and 95th percentiles ( $P_5$ ,  $P_{50}$ , and  $P_{95}$ ) were given.

## 17.4 Discussions

### 17.4.1 The Stability and the Reliability of the Data

The preset eligibility rate of review was 95 %. The test–retest reliability was checked out for every 100 pilots in order to control the quality of the anthropometric investigation [3]. It is found that the eligibility rates of review averaged 96.2 % in the range of 94.4–97.8 %. The data of human body measurements in sitting posture in GJB4856 are steady and reliable in general.

### 17.4.2 The Precision of the Percentiles

The precision of the 5th, 50th, and 95th percentiles were 0.9137–0.9913, 0.9905–0.9987, and 0.9480–0.9920, respectively, at 95 % confidence interval for

**Table 17.1** The fundamental items in sitting posture in GJB4856 (mm)

	Items	Definitions	$\bar{X}$	$s$	$P_5$	$P_{50}$	$P_{95}$
1	Sitting height (erect)	Vertical distance from a horizontal sitting surface to the highest point of the head (vertex).	927.4	24.7	887.0	928.0	969.0
2	Eye height, sitting	Vertical distance from a horizontal sitting surface to the outer corner of the eye	813.5	24.0	774.0	813.0	852.0
3	Inion height, sitting	Vertical distance from a horizontal sitting surface to the inion	800.9	26.4	760.0	801.0	845.0
4	Cervical height, sitting	Vertical distance from a horizontal sitting surface to the cervical	679.2	21.6	645.0	679.0	715.0
5	Shoulder height, sitting	Vertical distance from a horizontal sitting surface to the acromion	607.8	22.7	570.0	608.0	645.0
6	Elbow height, sitting	Vertical distance from a horizontal sitting surface to the lowest bony point of the elbow bent at a right angle with the forearm horizontal	260.7	22.7	223.0	261.0	297.0
7	Shoulder–elbow length	Vertical distance from acromion to the bottom of the elbow bent at a right angle with the forearm horizontal	347.1	14.9	324.0	347.0	372.0
8	Elbow-to-elbow breadth	Maximum horizontal distance between the lateral surfaces of the elbow region	434.9	32.1	385.0	433.0	491.0
9	Hip breadth, sitting	Breadth of the body measured across the widest portion of the hips	345.3	17.1	318.0	345.0	374.0
10	Lower leg length (popliteal height)	Vertical distance from the footrest surface to the lower surface of the thigh immediately behind the knee, bent at right angles	418.8	17.0	391.0	419.0	448.0
11	Thigh clearance	Vertical distance from the sitting surface to the highest point on the thigh	154.1	12.7	135.0	153.0	176.0
12	Knee height	Vertical distance from the floor to the highest point of the superior border of the patella	504.0	18.9	474.0	502.0	537.0

(continued)

**Table 17.1** (continued)

	Items	Definitions	$\bar{X}$	$s$	$P_5$	$P_{50}$	$P_{95}$
13	Trochanter height, sitting	Vertical distance from the sitting surface to the trochanterion	87.2	9.6	72.0	87.0	104.0
14	Grip reach; forward reach	Horizontal distance from a vertical surface to the grip axis of the hand while the subject leans both shoulder blades against the vertical surface	732.4	29.3	687.0	732.0	781.0
15	Elbow–grip length	Horizontal distance from back of the upper arm (at the elbow) to grip axis, with elbow bent at right angles	353.2	17.0	325.0	353.0	381.0
16	Forearm–fingertip length	Horizontal distance from the back of the upper arm (at the elbow) to the fingertips, with the elbow bent at right angles	454.6	15.8	429.0	455.0	480.0
17	Seat depth	Horizontal distance from the hollow of the knee to the rearmost point of the buttock	461.5	19.1	430.0	461.0	492.0
18	Buttock–knee length	Horizontal distance from the foremost point of the kneecap to the rearmost point of the buttock	567.2	20.9	534.0	566.0	602.0
19	Arm reach from back	Horizontal distance from a vertical surface to the fingertips while the subject leans both shoulder blades against the vertical surface.	833.8	29.1	789.0	834.0	885.0
20	Lower extremity length, sitting (buttock–heel length)	Projective maximum horizontal distance between the sole near the heel and the maximum posterior protrusion of the buttock while the subject sits and extend the lower extremity forward as far as possible with the anklebone bent at right angles	983.8	32.8	932.0	983.0	1040.0

(continued)

**Table 17.1** (continued)

	Items	Definitions	$\bar{X}$	$s$	$P_5$	$P_{50}$	$P_{95}$
21	Buttock–trochanterion length, sitting	Projective maximum horizontal distance between the trochanterion and the maximum posterior protrusion of the buttock while the subject sits	116.7	13.8	95.0	116.0	140.0
22	Knee circumference, sitting	Circumference of knee through the patella center point and the popliteal point with knee bent at right angles while the subject sits	377.5	20.3	348.0	375.0	413.0

the measurement items of GJB4856 in statistics [4]. The standard error of the 50th percentile was less than 2 % in practice. The precision of the data in GJB4856 can meet the general requirements of product design for pilots.

### 17.4.3 Comparison with GJB20-1984

There were 36 measurement items in sitting posture in GJB20 for 1,654 Chinese male pilots. The precision of the 5th, 50th, and 95th percentiles were 0.9396, 0.9967, and 0.9821, respectively, at 95 % confidence interval for the measurement items of GJB20, which are not different from that of GJB4856 by t-test in statistics [4].

There are 10 relative measurement items in sitting posture both in GJB4586 and GJB20. It is found that 7 of 10 measurement items were different statistically in size by *U*-test [4] ( $U = 5.02-15.82, P < 0.001$ ). Some key size for production design such as sitting height, eye height, seat depth, and arm reach from back were bigger in GJB4856-2003 with 8.4, 7.5, 4.5 mm, and 15.8 mm than the items in GJB20-1984. It seemed that some human dimensions in GJB4856 seemed to augment generally in comparison with that of GJB20 in view of body growth in measurement items in standing posture such as stature, leg length [5].

## References

1. GJB 4856-2003 (2003) Human dimensions of Chinese male pilot population. Military standard Publishing House of the General Armament Department, Beijing
2. GJB 20-1984 (1984) Pilot personal protective and life support equipment specifications. Military standard Publishing House of the General Armament Department, Beijing

3. Rong L, He W, Mengyang W et al (2001) Anthropometric error proofing site warning design. *Chin J Ergon* 7(4):27–30
4. Liu G (2000) (Ed) Probability theory and applied mathematical statistics. High Education Press, Beijing, pp 218–221, 251–263
5. Xiaochao G, Baoshan L, Hui X et al (2003) The liner dimensions of human body measurements of Chinese male pilots in standing posture. *Space Med Med Eng* 16(1):48–54

**Part II**  
**Research on the Machine Character**

# Chapter 18

## Research on the Design of the Ecological Atrium in the Architecture

Zhen Li

**Abstract** The atrium is an ancient concept. It has appeared in all kinds of buildings. Some methods about the atrium design are discussed in this paper from different aspects, in order to improve the ecological environment and reduce the energy consumption in the modern atrium buildings. The research used the comparative studying ways, combining various factors affecting the environment in modern architecture atriums. The best solution of the ecological atrium design is found by the analysis. It tells us the principles in the design of the ecological atrium from natural ventilation, the lighting, and virescence. All these aim at further understanding of the factors influencing the atrium, and providing a reference for the modern architecture design in the future. The conclusion of this paper can be applied directly to the design of public buildings, so as to effectively improve the ecological environment of our country. Thus, it is of great significance.

**Keywords** Atrium · Ecological environment · Energy consumption · Architecture design

### 18.1 Introduction

The atrium is a multi-functional space. It is both a transportation hub and the center of people's activities, thus it is known as a "shared hall" [1]. The atrium is an ancient concept. It has already been used for 2,000 years, up to the present. Now, it has been used in all kinds of buildings, such as the hotel, the business center, and the office building. Now, atrium has been a kind of rife form. It has

---

Z. Li (✉)

School of Civil Engineering and Architecture, Wuhan Polytechnic University,  
Wuhan, People's Republic of China  
e-mail: 66994752@qq.com



already become a kind of widespread building form in the architecture. Now, the architectural technology has developed constantly, and people bring natural environment into countries and buildings through the atrium. The atrium reinforces the relation of the people and the nature. It improves environment's quality and people's living standards.

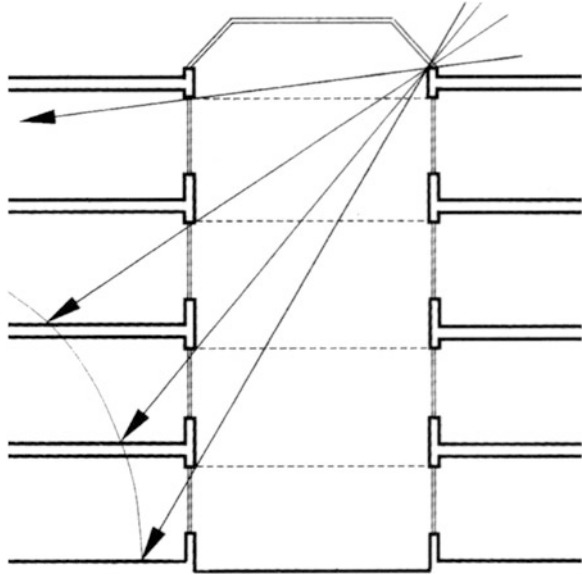
The atrium brings comfortable circumstance for us. At the same time, it brings us some troubles too, such as consuming large energy resources. As a result, the design of atrium should think about the peculiarity of atrium and take the different methods on building design in the vary areas. Only by this, it can afford a comfortable space for people.

At the end of the last century, the idea of ecological architecture was firstly proposed in the west and rapidly developed when facing the energy crisis. At the same time, the atrium space's positive role in many aspects has being recognized by more and more people. It not only is the modern architectural interior space, but also become the important means of ecological architecture design. In the new century, the research on the ecological architecture has just begun in China. A large number of ecological atriums appear in succession. However, some of them are actually passable due to the ill-considered design. The atrium's environmental quality is affected by quite a few factors. Thus, the paper intends to discuss the principles in designing ecological atrium from some different aspects. The research used the comparative studying ways, combining various factors affecting the environment in modern architecture atriums. The best solution of the ecological atrium design is found by the analysis.

## 18.2 Light Environment in the Atrium

The effect of the architectural physics environment to the people mainly manifests for the sensory stimulation, including visual, auditory, heat sensation, and smell. Therefore, effective control of environmental stimuli (sunshine, temperature, humidity, noise, etc.) is the main purpose of the people-oriented design. That is the environmental stimuli optimization, which can ensure the comfort of human activities [2]. At the same time, lighting quality has the most direct impact on the human. From the view of energy saving, the building should make full use of natural lighting. The atrium building structure has at least one glass side, which makes it an ideal natural lighting space. It is like a collector of natural light, bringing light to each layer plane. It can produce a transparent and changeful effect by the change of seasons and shadows. This has completely broken the sense of closure in an ordinary parallelepiped space. However, the design of light environment in the atrium is relatively complex. It involves many factors, such as the transparency of the building top, the atrium space's geometric proportion, and the reflectance of the wall.

**Fig. 18.1** The proportion of the atrium's height to width and the direct light's boundary



### *18.2.1 Geometric Proportion of the Atrium Space*

The proportion relationship among the atrium's length, width, and height determines the changing degree of its light levels. The floor in spacious and low atrium obtains more direct light. With the increase in the height of the atrium, the direct sunlight reaching the corresponding space rapidly reduces (Fig. 18.1). Thus, the atrium should be designed short to obtain sufficient sunlight at the bottom in the area with poor sunny condition. The maximum value of the atrium high aspect ratio is 3:1 upon study. The internal space can get enough natural light to meet the demand of human activities when the high aspect ratio is controlled at 3:1 value range. For the high and deep atrium with more protruding members, it is hard for natural lighting to reach the illuminance standard. In this case, it may be appropriate to use artificial lighting to compensate. A proper artificial lighting design can not only effectively improve the illumination in the room, but also increase the environmental atmosphere indoor and play a good decorative effect. But we should notice to control the proportion between the natural lighting and artificial lighting so as to save energy.

### *18.2.2 The Transmittance of the Top of the Atrium*

The transmittance of the light at the top of an atrium is another key aspect affecting the lighting effects. More light can reach the bottom of the atrium and adjacent

room when the transmittance of the top is higher. The ordinary glass and Low-E glass with smooth surface has good transparency. Sunlight can enter the room directly. But the light distribution at the horizontal level is uneven and will produce glare. At the same time, the frosted glass and the transparent membrane structure with a rough surface can avoid the glare effectively and realize a uniform diffusion of the sunlight. But the amount of the incident light decreases greatly. The effects of different translucent materials are different. Actually, we should make a choice of the transparent material according to the other influencing factors of the light environment in the atrium, especially the geometric proportion of the space.

The glare entering the atrium will cause environmental overheating in summer. Otherwise, the inappropriate sun-shading manner can block the sunshine in winter and influence people's feelings. The way to resolve this contradiction is to find a reasonable treatment for the atrium's shade. Firstly, the saw-toothed skylights can be considered. Let the roof plate both turn toward the sun and make the glass back to the sun. It can both avoid the direct sunlight and make the light reaching the roof be reflected back into the atrium, which improves the illumination indoors. Secondly, a movable sunshade system can be used (such as a movable shutter), and let the sunshade angle changes with the seasons, so as to achieve an effective control of the amount of light transmission at the top.

### ***18.2.3 Reflection of the Atrium Walls***

There is reflected light and diffuse light in addition to direct light coming into the atrium. For the ground floor and the adjacent space, the latter two are particularly important. Vertical walls of the atrium redistribute the daylight and readjust the lighting effect by the reflection and diffuse reflection. Experiments have shown that diffuse light is more soft and uniform than the rough wall surface, and it is hard to produce glare. Therefore, the atrium walls should be made of plain concrete, light-colored stucco, gypsum board, rough stone materials, etc. To the contrary, such smoothy materials as the marble and glazed tiles should be avoided. If it needs to increase the amount of natural lighting at specific parts, the adjustable mirrors installed on the atrium walls can be used. They can reflect the daylight downwards so as to solve the problem that the natural light is insufficient at some parts.

## **18.3 Thermal Environment Design**

Thermal environment is another important aspect of a building's physical environment, including temperature, humidity, and wind speed. Since the atrium space generally has a glass enclosure cover, through which the daylight can go inside, it

can easily cause intolerable feelings in summer and winter if the design is not proper. At the same time, the shape and structure of the atrium determines two natural phenomena: the greenhouse effect and the chimney effect. These phenomena must be researched and used seriously to get comfortable thermal environment in the atrium.

### ***18.3.1 Greenhouse Effect of Atrium***

Solar shortwave radiation through the glass can warm the building's interior surface. But the longer wavelength (about 10 microns) of the secondary radiation from the interior surface cannot pass through the glass and shot back outside, thereby solar power is stored inside and the temperature of atrium rises. This is the greenhouse effect in the atrium. The atrium's main function in north China is lighting and heating. So special attention should be paid to using the effect to raise the room's temperature in winter. First of all, it must be ensured that the atrium faces toward the sun to get sunshine as much as possible. It can be designed at the south with a side-lighting form. This may not only ensure the atrium to gain enough sunlight and warm up quickly, but also avoid the strong sunlight from the top in the summer. Secondly, we should choose a good form of the atrium's structure with a satisfying thermal performance, such as the adjustable curtain wall. Besides, such heavy material such as the brick and the concrete block can be used with the interior decoration, in order to maintain a good heat storage of the interior space and prevent the heat loss at night. Through the above methods, the artificial heating costs and the energy consumption can be greatly reduced in the cold winter.

### ***18.3.2 Chimney Effect of Atrium***

Because the atrium usually has certain height, and a certain temperature difference exists between the upper and lower height, it causes the thermal pressing ventilation, which is named the chimney effect [3]. By the chimney effect, hot air rises and cold air falls. In this way, a regular indoor natural ventilation without the aid of mechanical means forms. This can both realize the effect of ventilation and save energy, which is of great significance to the atrium in the summer at the hot districts. Effect of the hot pressure ventilation is determined by the difference between indoor and outdoor temperature as well as the height of the atrium's opening. The greater the temperature difference is and the higher the air outlet is the stronger effect we can get. Hot pressure difference and outlet's opening area determine the gas flow rate in the unit time. So, we can improve the heat ventilation's efficiency from two aspects in the design of the atrium in hot area. On the one hand, the vent area should be expanded. We can use the open sunroof with

adjustable sunshade grills. All the sunroofs may be opened in hot weather. With the expansion of the vent area, the air flow speeds up and the thermal natural ventilation indoor will be more powerful. On the other hand, the outlet's height ought to be raised appropriately, so as to increase the temperature difference between the upper and lower air. In this way, the effect of pulling the wind is more obvious.

## **18.4 Atrium Greening Design**

### ***18.4.1 The Significance of the Atrium Greening***

Modern people stay insides for a long time in big cities, exposure to benzene, formaldehyde, and other harmful substances. It is easy to induce “building syndrome” and “air-conditioning disease” [4]. Greening can improve the building's environment, and it is the best way to build green houses. Therefore, it is an indispensable means to design the eco-building atrium. Atrium greening has three functions.

First, it can improve the quality of the environment significantly. Plants release much oxygen by photosynthesis. This makes people feel pleasant more. Moreover, plant's respiratory function may filter the air, reduce the indoor temperature, and improve the micro-climate. It is the environmental and ecological regulator.

Second, it is rich in the space hierarchy. Various plants have specific morphology. We can create a colorful and natural scene with them. At the same time, large space can be divided into different and tasty small space by limiting and diverting plants. They are separated as well as mutually penetrated, softening the building's blunt sense.

Third, it has a visual function and psychological infection. Plants have various shapes, lines and colors, which gives us a feeling of beauty. The atrium will be vigor with the trees, flowers, potted plants, and spider plants. In addition, the flowers in spring, green in summer, colors in autumn, and plant's posture in winter make us come to realize the change of time and the cycle of seasons. Thus, people get a touch of mind and then produce a strong artistic resonance.

### ***18.4.2 Tips for a Atrium Greening***

Environment in the atrium differs greatly from the nature. So, it is a foundation for the greening landscape design to select appropriate varieties of plants, which is suitable for the special environment. Indoor sunshine intensity and time are far less than the open-air condition. Thus, plants in tropical and subtropical regions should be mainly used. They are more shade-tolerant and have strong resilience with the

atrium's environment. At the same time, the selected plants should also be higher ornamental. They need beautiful or unusual morphology. The shape and color of the leaves should be nice or they are in bloom and can bear attractive fruits. Such plants as the delicate bamboo, tall and stout pines, colorful sunflowers, and dates are all good choices [5]. In addition, the plants should be non-toxic and have no bad smell and no acne flying to protect people.

It is emphasized on the plant landscape's multiple levels. Atrium's ground floor, the corridor, and roof platform must be considered together, so as to form a complete greening system. Only in this way, can it meet viewers' visual requirements from different height. Green landscape should echo the characteristics of the atrium's usage and create different styles of space images. [6] It may be warm, quiet, noisy, or romantic, etc. Besides, the plants need work in concert with other landscape elements in the environment, such as lights, sketches, water, furniture, to form a same style and the harmonization in colors.

## 18.5 Conclusion

Atrium is a transitional space between the building and the external environment. It can enhance the whole building's vitality to create a successful atrium. This requires that the designer should study the relationship between architecture and people seriously. We must use the most appropriate technical means combined with local climate condition, so as to ensure a good ecological efficiency of the atrium space. Only in this way, it can meet the spirit of the sustainable architecture design and protect human beings as well as the natural resources at the same time. This study reveals the restrictive factors of ecological atrium, and the conclusion can be applied directly to the design of public buildings, so as to effectively improve the ecological environment of our country. Thus, it is of great significance.

## References

1. Liu J, Weng Ji (2008) Building construction. Chinese Construction Industry Press, Beijing, pp 152–153
2. Xiaoyun P (2001) Physical environment and energy efficiency in atrium. *Huazhong Archit* 19(4):58–59
3. Peng X (2009) Research on daylighting and architectural design of building atrium having a curtain wall. *Sichuan Building Sci* 35(1):204–207
4. Fang Z, Wu W (2006) Nonecological significance of atrium greening. *J Nanjing Forest Univ* 6(2):92–94
5. Sekkei N, Kaisha K (2000) Sustainable architecture in Japan. Wiley-Academy, New York, pp 120–122
6. Rosenberg NJ, Blad BL, Verma SB (1983) Microclimate: the biological environment. Wiley-Interscience Publication, New York, pp 84–86

# Chapter 19

## On-Orbit Mission Assisting and Supporting System Based on AR

Xiuqing Zhu, Yuqing Liu and Bohe Zhou

**Abstract Objective** In the future deep-space exploiting missions, due to communication delay, astronauts cannot depend on the instructions of control center completely. In the long-duration on-orbit missions, astronauts are likely to disremember the operation procedures of some tasks that ever be performed seldom, despite they had been trained on the ground in advance. To help astronauts to cope with these situation by themselves, AR, which can enhance human's perception and interaction with the real world, is a feasible solution. **Methods** Applying AR, such as three-dimensional registration and perspective projection, assisting information of the task procedure was superimposed on the real scenes, whose showing pace was controlled by voice instructions, so astronauts can focus their hands on their tasks, referencing assisting information to do their work. **Results** A prototype system was realized based on AR, which can help astronaut to do operation of a specific device. **Conclusion** The AR assisting system affords an effective tool for astronaut task supporting and training on orbit and also adapts to training on ground and has an expansive applying prospect.

**Keywords** Augmented reality · Long-duration space flight · Training · Astronaut

### 19.1 Introduction

Technology of Augmented Reality (AR) integrates variant forms of digital information, including figures and characters generated by computer, into the real-world scenery which can be seen by users and augments human vision perceptual performance [1]. In the long-duration flight task of future space station, although

---

X. Zhu (✉) · Y. Liu · B. Zhou  
National Key Laboratory of Human Factors Engineering, China Astronaut Research and Training Center, Beijing, China  
e-mail: zz\_xx\_qq@126.com

astronauts had been trained on the ground in advance, they shall be avoided forgetting due to long duration. Though the operation information could be found out in all kinds of operating manual or electronic documents, the working efficiency will be lower. Moreover, in the exploration activities of deep space in the future such as flying to small planets and Mars, the communication with the ground control center would be lengthened. For example, the unidirectional delay between Mars and earth can be up to 22 min, and it is difficult to depend on the real-time guidance on the ground. Applying AR technology to realize auxiliary task-supporting system, forming the task prompting information in the form of text, images, videos, or three-dimensional models according to the operational procedures designed by the task, displaying the information within the visual scope of astronauts and assisting them to complete the task process can substantially lessen the task load of astronauts and improve the working efficiency [2–5]. European Space Agency (ESA) had designed and realized a Wearable Augmented Reality (WEAR) system assisting the astronauts and had completed the orbit test, so as to test the feasibility in the space task application [6, 7]. American NASA Johnson space center had designed and applied AR system to assist the astronauts to conduct the robot arm operating drills. The system could improve, under the poor light conditions, astronauts' recognition and judgment on manual operation objectives, to improve the operating accuracy and speed [8, 9].

## 19.2 Design Methods

### 19.2.1 System Structure

System is composed of interactive interface and calculation processing equipment. Human-machine interactive interface can be divided into information input and output interface. The typical optical see-through AR system usually includes optical see-through helmet, graphic workstation, and tracking and interacting equipment. In our system, the helmet is a Cybermind Visette45 optical see-through HMD. A common net camera is used as tracking camera, fixed on the top of helmet eyepieces (Fig. 19.1).

Input information includes head position-tracking data and voice message. Head track is realized by installing camera on helmet; the head position is indirectly indicated by calculating the calibrated camera position applying computer vision arithmetic. The role of head position tracking is to make the observed virtual information changed while the head of astronaut turns. Human-computer interaction is realized through voice input so as to control the presenting steps of augmented message. Information output includes the output of visual information and audio information. Helmet is the visual output equipment. The scene and operation sound effects are fed back through auditory information.



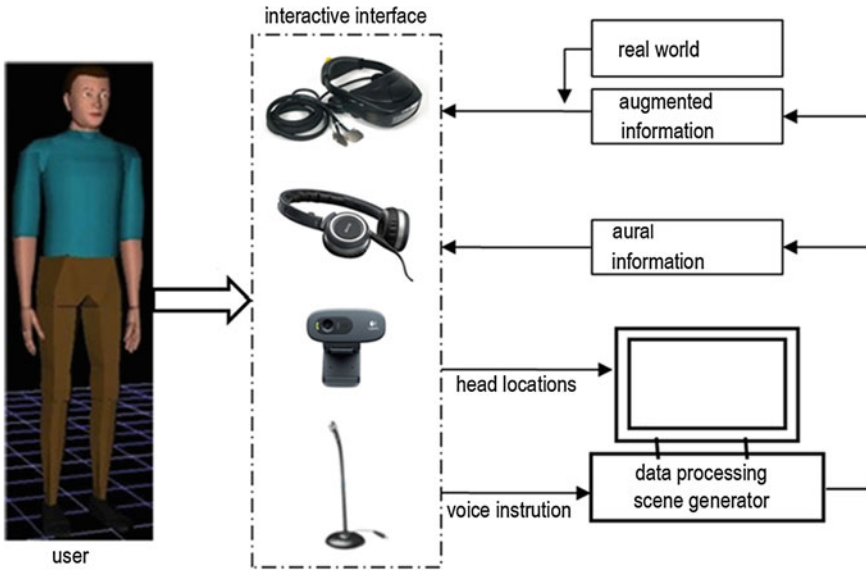


Fig. 19.1 Scheme of assisting system-based AR

## 19.2.2 Selection of Marker Pattern

AR system needs to overlap the virtual information within the real time to the real scenery. In order to guarantee the correctness of information overlapping position, the coordinates matching of virtual and actual space must be completed, that is, three-dimensional registry. Three-dimensional registry is determined by the coordinate-corresponding relationship of feature points at scenes on the display plane. Considering the environment limitation of the narrow space cabin and the flexibility and portability of registry equipment, the system adopts the registry technology based on visual features. Under the real circumstance, the extraction and identification of calculation of nature features are very complex and time-consuming, usually difficult to meet the real-time requirement. Therefore, the registry method based on artificial identity is widely used. Currently, the common artificial identity system includes ARToolKit and ARTag. This paper makes comparison and analysis on the working performance of the two kinds of marker system.

### 19.2.2.1 Comparison of Minimum Marker Size

Minimum marker size is the pixel size of marker pictures formed through camera shooting of marker points. The marker points of ARToolKit and ARTag are arranged at the positions 60 cm away from camera. The experiment selects 24 ARToolKit marker points and ARTag marker points in 7 different sizes, so as to compare the

identifying ratio of the two types of marker points. The image resolution of marker points shall be 72 pixels per inches. Through experiments and comparison, AR-ToolKit shall reach 100 % of the resolution ration, but its identifying image requires 150 pixels, while ARTag identifying image can be only 120 pixels.

### **19.2.2.2 Running Speed**

System running speed is an important indicator to assess a marker system. The quicker the system run, the closer the processing time to nearly synchronous, the better bonding the virtual information and real information can be. Conduct tests respectively according to the different marker pattern amount, so as to test the identifying rate of two marker systems with recorded different amount markers.

ARToolKit algorithm principle is to retrieve the images matched with the preloaded marker templates from the images shot by camera. If the preloaded templates are numerous, they shall be in contrast one by one with the target marker. This will reduce the running speed of algorithm. ARTag does not have this issue. Thus, while the marker group is large, using ARTag marker system would get quicker running speed.

### **19.2.2.3 Performance of Preventing Occlusion**

During the extraction process of feature districts, both ARToolkit and ARTag are regionally recognized with the square outline as the boundary features. ARToolkit firstly makes binarization processing of gray level on images, then sets up a fixed threshold to segment the images, and searches the connected domain contour in the derived black–white images. ARTag also firstly makes binarization processing on images and then abstract quadrangle. Different from the connected field of identification adopted by ARToolkit, ARTag adopts the algorithm based on boundary. This method firstly abstracts all the straight line in the objective images and then finds the line segment composing the quadrangle as contour of objective area.

Comparing the abstracting process of feature regions of the two kinds of marker point system, ARToolki fails to successfully abstract the feature regions under the circumstance of incomplete marker outline border due to the use of connected domain abstracting algorithm. ARTag can still identify partial disturbed marker due to the algorithm based on boundary, even though the pixels of framework are incomplete.

## ***19.2.3 Helmet Calibration and Three-Dimensional Registry***

Three-dimensional registry technology is not only the fundamental technology to realize the AR and the key technology to guarantee the system performance of AR.

Thus, it is an important direction of system research of AR. When the head moves, the scenery observed by eyes will change with the head moving. Thus, the augmented information generated by computer would change correspondingly. Thus, AR system must be able to detect the head position and sightline direction in time, then determine mapping positions of the added virtual information in the real world according to this information, and display this information at the correct positions of display unit [1–3].

This system adopts the calibrating method based on Single-Point Active Alignment Method (SPAAM). SPAAM utilizes a calibration target in real scenes for optical see-through helmet calibration. Users observe the target through the optical see-through helmet screen and then use mouse to control the virtual target on the helmet display screen, making it align to the calibration target through the helmet display screen. Due to the alignment of target virtual image and real image, involve the translation and rotation transformation of target coordinates, that is, transformation from a coordinate system to another coordinate system for target coordinate points. Target coordinate transformation includes from world coordinate system to tracking coordinate system, then display coordinate system. The transform matrix from tracking coordinate system to display coordinate system is a fixed point  $M_{td}$ . Keeping user's head in movement, we can get the target point's coordinates in tracking coordinate system and display coordinate system respectively are  $P_t$  and  $P_d$ . Establish the equation set and solve the transform matrix  $M_{td}$ . The matrix is the  $3 \times 4$  matrix integrating human eye visual virtual camera lens internal and external parameters. There are 11 parameters to be solved in all. Thus, six head tracker gesture positions with different directions are required to measure coordinate points  $P_t$  and display coordinate points  $P_d$ . Each calibrating points can determine two independent restricting equations and then transfer matrix calculated by least square method or direct linear transformation method.

### ***19.2.4 Interaction Design by Speech Command***

Under the space microgravity environment, astronauts not only require two hands for operating tasks, but also have to control body movement and gestures. Thus, the interaction with computer should avoid the interacting action with hands, so as to make the two hands focus on operating task. Thus, voice interaction becomes the choice of interacting means.

This paper adopts Microsoft Speech API (SAPI) voice developing engine of Microsoft, which provides the interface of data exchange between voice identifying application program and voice engines and can help users to realize all kinds of adjustment and management of engines involved in voice recognition. The utilization of SAPI library functions realizes all kinds of functions of the whole voice identifying program, including the adjustment of microphone, voice drill, and instructional voice recognition.

Voice recognition system mainly uses the interface components in applying voice engine library.

1. Voice Commands API: This component is mainly used for the control of application program. Generally, it is used in the voice recognition system. After recognizing some orders, call the related interface to make the application to complete the corresponding functions. This paper mainly uses the interface functions of the components.
2. Voice Dictation API: This component is used for monitoring the users' voice as the voice recognition interface.
3. Voice Text API: This component is used for changing the words in the text as voice files, that is, voice synthesis.

This paper mainly realizes the command-voice recognition. Users give out speech command, voice recognition system triggers graphic generation system through the recognition user command to load the corresponding auxiliary operating information.

### 19.3 Results

On the basis of the above-mentioned basic technological analysis, it realizes the auxiliary operating supporting system based on AR through integration design. The auxiliary guidance function of partial operating process is realized through the operating procedures of equipment.

According to the using course of equipment, present the equipment operating method through optical see-through helmet in the form of virtual auxiliary information for users, to guide the user operating as per the information prompting (Fig. 19.2).

During the actual operating process, users gives out speech command control operating prompt information like "Start," "Next," "Quit," and "Finish" through presenting process of voice command auxiliary information. When users give out instructions, the system firstly recognizes the artificial markers in the camera images. According to the identified marker, load the corresponding equipment course; tell the operators about the equipment name being operated. When users give out the next orders, systems load the auxiliary operating information of corresponding steps (Fig. 19.3).

The testing results show that system can correctly respond to the users' voice command and correctly recognize the marker and display the auxiliary information to be loaded on optical see-through helmet display correctly. Under the virtual auxiliary information guidance, users can quickly enter the working status and complete the testing equipment operational task as per the requirement. The example procedure records the time differences from users giving commands to helmet displaying virtual auxiliary information, average as 0.13 s, not affecting the user' operating timeliness.



Fig. 19.2 A user is practicing the AR system

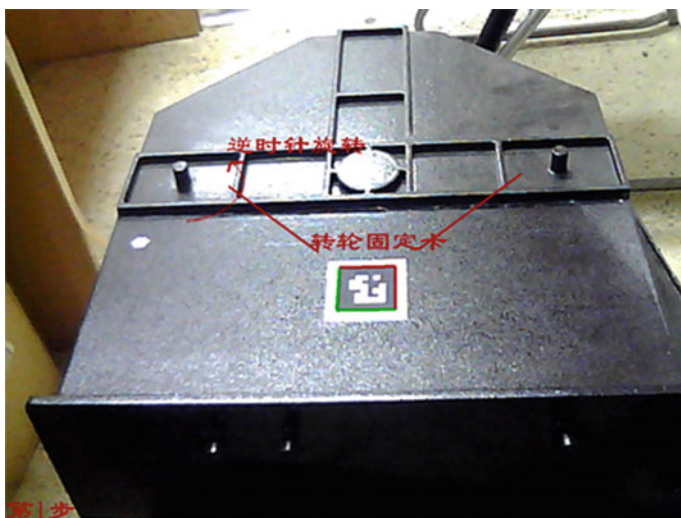


Fig. 19.3 Augmented information is superimposed on real world

## 19.4 Conclusions

This paper applies AR technology to realize the auxiliary supporting system of astronauts operation, explore the feasibility of system, design systemic framework and testing platform, and create technological conditions for following comprehensive research. The practicability and stability of system are expected to be verified by tests further. Ideal AR system can reach the recognition on objectives under the conditions of no auxiliary markers. The present technological development is difficult for perfect realization. Adopting the recognition algorithm with markers is beneficial to improve the objective recognizing efficiency and increase the usability of the system. ESA's testing system also uses bar code equipment identifying system, which can determine the task's targets more quickly, improve the recognizing efficiency. Furthermore, auxiliary using other registered positioning method, such as CAD model map adopting objective environment, may realize more accurate positioning and improve the registered speed and accuracy [6, 7]. The follow-up research direction mainly includes the portability and miniaturization of registry, display and calculating equipment, the improvement of registry speed and accuracy, as well as the organization and management methods of auxiliary information.

**Acknowledgments** This study is funded by Foundation Scientific Research Plan of National Defense (B1720132001) and China Space Medico-engineering Proactive Research Program (2010SY5413004).

## References

1. Ronald A (1997) A survey of augmented reality. In: *Presence: teleoperators and virtual environments*, vol 6(4), pp 355–385
2. Regenbrecht H, Wilke GBW (2005) Augmented reality projects in the automotive and aerospace industries. *IEEE Comput Graphics Appl* 25(6):48–56
3. Steven JH, Steven KF (2007) Augmented reality for maintenance and repair (ARMAR). AFRL-RH-WP-TR-2007-0112
4. Jeffrey OB (2012) Virtual reality: avatars in human spaceflight training. *Acta Astronautica* 71(2):139–150
5. Memi Ed (2006) Boeing's working on augmented reality, which could change space training, ops. *Boeing Front* 10:21
6. Tingdahl D, Van Gool MVL et al (2011) WEAR++: 3D model driven camera tracking on board the international space station. In: *International conference on 3D imaging 2011 (IC3D 2011)*, Liège, Belgium
7. Fabrice S, Alexander N, Horst K et al (2010) Operation of European SDTO at Col-CC[R]. AIAA 2010–2259
8. James CM, Charles KB, John P (2006) Enhanced lighting techniques and augmented reality to improve human task performance. NASA/TP-2006-213724
9. James CM, Charles KB, John P (2007) Improving robotic operator performance using augmented reality. In: *Proceedings of the human factors and ergonomics society 51st annual meeting*, pp 1635–1639

# Chapter 20

## Manufacture Process Evaluation of IFOG Using Multiple-Test Data Analysis

Lianjie Shan, Yingchun Liang and Haoting Liu

**Abstract** To control the product quality of interferometric fiber-optic gyroscope (IFOG), an integrated evaluation method of manufacture process is proposed. First, some key manufacture processes are selected: the winding and length control of fiber-optic coil, the fiber splicing operation, and the light leakage detection of IFOG light path. Second, the important test data of each key manufacture process are collected as the evaluation indexes. The test data include the winding precision, the length control precision, the splicing effect, and the light leakage intensity. Third, the classic analytic hierarchy process (AHP) technique is utilized to evaluate the manufacture process effect of IFOG. By using the proposed technique, the process quality of IFOG can be controlled effectively. Many experiment results have proved the correctness and effectiveness of our proposed method.

**Keywords** IFOG · Manufacture process · Test data analysis · AHP · Product quality evaluation

### 20.1 Introduction

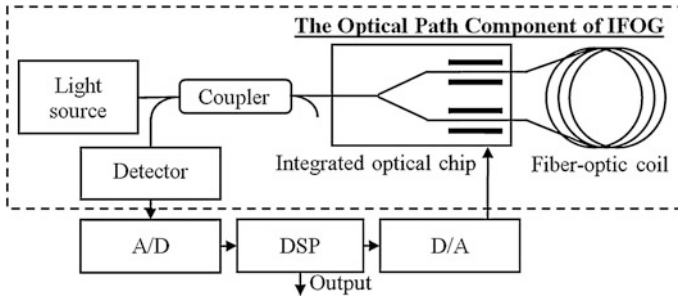
As a kind of precise instruments, the design and manufacture of interferometric fiber-optic gyroscope (IFOG) [1] relate to optoelectronics, thermal science, mechanics, materials science, etc. Its assembly processes also include numerous of

---

L. Shan (✉) · Y. Liang  
School of Mechatronics Engineering, Harbin Institute of Technology,  
Harbin, China  
e-mail: jenny\_shan@126.com

Y. Liang  
e-mail: ycliang@hit.edu.cn

L. Shan · H. Liu  
China Academy of Aerospace Electronics Technology, Beijing, China  
e-mail: imkyran@hotmail.com



**Fig. 20.1** The working principle diagram of a kind of IFOG

serial and parallel operations which are large than thirty steps. Thus, it is very difficult to evaluate and control the manufacture quality of such a complex industrial product [2]. In this paper, to conquer that problem to some extent, a manufacture process evaluation method of a kind of IFOG is proposed. Figure 20.1 shows us the working principle diagram of that IFOG. From Fig. 20.1, we can see the IFOG include at least 6 parts: the light source, the coupler, the integrated optical chip, the fiber-optic coil, the detector, and the digital circuit system. Each element of IFOG has its own optical or electronic characters; in addition, its assembly process will also create lots of control parameters; therefore, it is necessary to develop an integrated quality evaluation method for the manufacture process of IFOG.

When evaluating the manufacture process quality of complex product, many corresponding techniques have been developed. In [3], the authors have proposed to use the statistical decision theory and the multiple hypothesis aspect of rule set to evaluate the manufacturing quality of an automotive industry. In [4], the authors have developed a parameterized expression of the assembly tolerance to improve the reliability of multi-support axis systems. The SVM is utilized to decrease the number of simulations. These techniques above are effective to solve their own problems; however, as for the IFOG, the multidisciplinary barrier and various kinds of manufacturing parameters make it is impossible to use some special models or methods to build the quality evaluation issue of such a complex device.

In this paper, an integrated quality evaluation technique is developed for the IFOG. First, some key steps are selected from the whole manufacture processes: the winding and length control of fiber-optic coil, the fiber splicing operation, and the light leakage detection of IFOG light path. Second, the important test data of each key manufacture process are collected as the evaluation indexes of the IFOG manufacture quality: the winding and the length control precisions of fiber-optic coil, the splicing effect parameters (the splice loss and extinction ratio), and the light leakage intensity, etc. Third, the analytic hierarchy process (AHP) technique [5] is used to evaluate the manufacture process effect of IFOG. The main contributions of this paper include: First, the AHP is used to evaluate the manufacture



process of IFOG and second, the multiple test data are defined as the evaluation indexes of IFOG process quality firstly in our research work.

In the following sections, first the manufacture process technique of IFOG is presented. Second the AHP-based evaluation method of manufacture process is introduced. Finally, an application case is shown and discussed.

### 20.2 Manufacture Process Techniques of IFOG

Figure 20.2 shows us the key manufacture process techniques of IFOG: the winding and length control of fiber-optic coil, the light leakage detection of IFOG light path, and the fiber splicing operation. As a measurement device of Sagnac effect [1], the fiber-optic coil is the heart of IFOG. Thus, the process quality requirements of fiber-optic coil manufacture include the abnormality monitor of fiber-optic coil winding and the accurate length control of it. The winding and the length control precisions of fiber-optic coil [6] will be recorded during that process. The light leakage detection of IFOG light path is to use the infrared camera to implement a complete traversal of each fiber body in IFOG so that the surface defect of light path should be found and avoided. The light leakage intensity can be regarded as a test data index of that processing step. The fiber splicing operation [7] is to utilize the fiber splicer to connect the separated fiber together. The splicing process is carried out by heating and connecting fibers by consequent electricity. The splicing effect parameters, such as the splice loss and the extinction ratio, are all collected as the test data indexes.

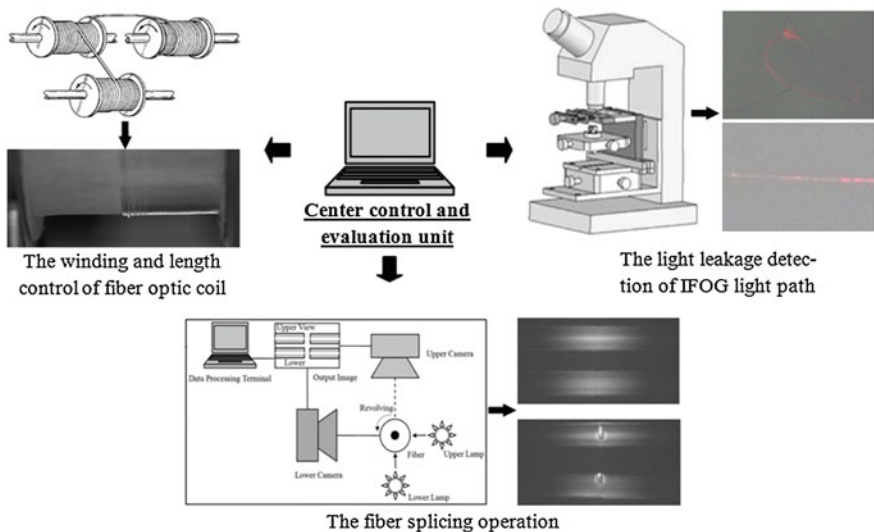


Fig. 20.2 The key manufacture processes of IFOG

### 20.3 Evaluation Method of Manufacture Process

In this paper, we propose to use the AHP to evaluate the manufacture process quality of IFOG. The AHP is a multiple layer decision computation technique which uses both the qualitative and the quantitative methods to find the importance rank of evaluation factors. When implementing AHP, first, the multiple basic judgement matrixes should be estimated by the opinions of experts. Then, those basic judgement matrixes will be combined to build an integrated evaluation matrix. After that the prototype test will be carried out. Finally, the maximum eigenvalue and its corresponding eigenvector will be calculated. Thus, the importance rank can be gotten according to the weight values of that eigenvector. Many applications are developed to use AHP for quality evaluation of industrial products or operations. In [5], the authors have proposed to use a fuzzy AHP to build their multiple quality characteristics decision model. In [8], the authors have also employed AHP and grey relative analysis process (GRAP) to evaluate and select their suppliers. In this paper, we use the classic AHP to evaluate the manufacture process [9] of IFOG because of the variety of its quality evaluation factors.

Figure 20.3 shows us the manufacture process evaluation hierarchy of a kind of IFOG. From Fig. 20.3, we can see that for each manufacture process, we can choose three factors to evaluate their final process quality: as for the winding and length control of fiber-optic coil, the winding precision, the abnormality type (the overlap type and the vacancy type), and the length control precision are recorded; as for the light leakage detection of IFOG light path, the light leakage intensity, the light leakage type (the point type, the wedge type, and the surface type), and the light leakage size are considered; as for the fiber splicing operation, the splicing

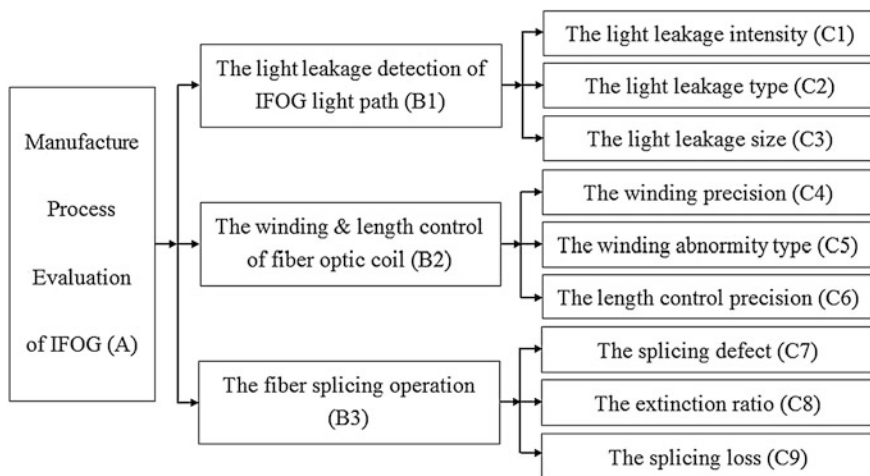


Fig. 20.3 Manufacture process evaluation hierarchy of a kind of IFOG

defect (the bubble defect type, the wrinkle defect type, and the dislocation defect type), the extinction ratio, and the splicing loss are utilized. Then, we can query the opinion of experts to get the judgement matrixes of each factor above. The important weights of 1–9 are considered in our matrixes. Finally, the classic AHP method can be used to assess the importance rank of each factor. The larger the final weight is, the higher the importance rank of this process factor should be.

## 20.4 Experiments and Discussions

In this paper, to illustrate the effectiveness of our proposed technique, first an application case is shown; then, we make a discussion about the application of AHP on the quality evaluation of complex aerospace electronic device.

### 20.4.1 Simulation Experiments

Tables 20.1 and 20.2 present the judgement matrix samples of the IFOG manufacture process evaluation issue in Fig. 20.3. All these comparison weights are advised by experts. For example, the value of C1–C2 (vertical to horizontal directions) equal to 6.0 means the factor of light leakage intensity (C1) is important than the factor of light leakage type (C2). Similarly, the value of C9–C8 equal to 2.0 means the factor of splicing loss (C9) only has small importance than the factor of extinction ratio (C8). From Table 20.2, we can see that according to the opinion of expert, the manufacture process of light leakage detection is far more important than that of the winding and length control of fiber-optic coil. And it also has some importance advantages than the fiber splicing operation. This is

**Table 20.1** The judgment matrix samples of the second and third layers of the IFOG manufacture process evaluation problem in Fig. 20.3

–	C1	C2	C3	–	C4	C5	C6	–	C7	C8	C9
C1	1.0	6.0	8.0	C4	1.0	9.0	5.0	C7	1.0	8.0	7.0
C2	0.1667	1.0	3.0	C5	0.1111	1.0	0.5	C8	0.125	1.0	0.5
C3	0.125	0.333	1.0	C6	0.2	2.0	1.0	C9	0.1429	2.0	1.0

**Table 20.2** The judgment matrix samples of the first and second layers of the IFOG manufacture process evaluation problem in Fig. 20.3

–	B1	B2	B3
B1	1.0	7.0	3.0
B2	0.1429	1.0	0.25
B3	0.3333	4.0	1.0

**Table 20.3** The final weight computational results of Tables 20.1 and 20.2

C1	C2	C3	C4	C5	C6	C7	C8	C9
0.5013	0.1095	0.0478	0.0598	0.0064	0.0124	0.2059	0.0214	0.0355

because the IFOG is a fiber-based device, if the light is leaked, the measurement precision of IFOG will decrease dramatically. As a result, other quality defects should be less important than the manufacture process of fiber-optic coil.

Table 20.3 shows us the final weight computational results of Tables 20.1 and 20.2. In Table 20.3, we can see that the largest weight is the light leakage intensity (C1), the second largest weight is the splicing defect (C7), and the smallest weight is the winding abnormality type (C5). That means the light leakage intensity is the most important factor which will affect the final manufacture process quality of IFOG. This result looks different than our common sense. However, the computation result of AHP is objective. As we know, as a Sagnac effect measurement device, in our mind the manufacture process quality of fiber-optic coil is the most important factor of IFOG; however, as for the illustrated IFOG product in Tables 20.1 and 20.2, the manufacture defects are the main reason of quality problem; thus, the experts bid the weight according to that fact justly. As a result, the AHP will mine that conclusion correctly. When the multiple factors coexist, it is very difficult to make a fair judgment of the final evaluation target. In that situation, some subjective conclusions may lead us to get a wrong judgment. That is why we use the AHP to evaluate the manufacture process quality of complex IFOG device.

### 20.4.2 Result Discussions

The manufacture process evaluation of complex electronic product is a difficult issue for all the aerospace industry. Because of the multidisciplinary cross of complex processes [10], the quality defect almost cannot be avoided. The AHP method can be used to solve problem which is influenced by multiple factors: if those factors have a hierarchy relationship and an apparent division type; and the final evaluation factor cannot be assessed by them easily. As for the discussed manufacture process evaluation of IFOG, its product quality is affected by the winding of fiber-optic coil, the splicing of fiber, and the assembly of light path component. If we only regard the process of fiber-optic coil as the most important affect factor without any analyses, this conclusion may lead to a wrong judgement. During that manufacture process, many manufacture parameters will be created. Some of them look important; however, because the manufacture stability of those parameters is good, they will not influence the final product quality. On the contrary, other factors seem unimportant; but they will lead to serious quality problem because of the limited manufacture precisions or defects. What's more, as for the industrial department, what they concern is which parameter is the most

important factor related to the final quality of IFOG product. To answer that question, we propose to employ the AHP to search an importance order of those manufacture process parameters (i.e., the test data), to give a guidance of complex product manufacture.

## 20.5 Conclusion

Currently, the industrial department does not have any integrated technique to evaluation the manufacture process quality of IFOG. A multiple test data analysis-based manufacture process evaluation method of IFOG is proposed in this paper. First, some important processes are selected from the whole manufacture procedures. They include the winding and length control of fiber-optic coil, the splicing operation of fiber, and the light leakage detection of IFOG light path. Second, the important test data of these manufacture process are collected and were used to build the judgment matrix. Third, the classic AHP method is employed to evaluate the integrated manufacture process quality of IFOG. In future, other mathematical tool, such as the fuzzy AHP method, can be utilized to improve the computational effect of our proposed method.

## References

1. Wang W (2010) Introduction of the interferometric fiber optic gyroscope technology. China Aerospace, Beijing
2. Heckman DW (2000) Interferometric fiber optic gyro technology (IFOG). *IEEE Aerosp Electron Syst Mag* 15:23–28
3. Strobel CM, Hrycej T (2006) A data mining approach to the joint evaluation of field and manufacturing data in automotive industry. *PKDD LNAI* 4213:625–632
4. Wang H, Yu T, Pang H, Song B (2011) Mechanism reliability simulation analysis for multi-support axis seizure considered assembly tolerance. In: *ICQR2MSE, IEEE*, pp 35–41
5. Zhang G, Pang J (2010) Use FAHP to evaluate the quality of CNC machine tools based on multiple QCs decision model. In: *ICMACE, IEEE*, pp 2628–2631
6. Liu H, Wang W, Li X, Gao F (2013) Automatic abnormality detection for winding and splicing of fiber-optic coil. *Chin Opt Lett* 11:101501-1–101501-4
7. Liu H, Wang W, Li X, Li F (2012) Defect segmentation of fiber splicing on an industrial robot system using GMM and graph cut. In: *ROBIO, IEEE*, pp 1968–1972
8. Zhao X, Liang T (2008) The supplier evaluation model based on the analytic hierarchy process and grey relative analysis process. In: *ICAL, IEEE*, pp 2209–2213
9. Wylie N, Wylie SR, Cullen JD, Al-Jader M, Al-Shamma'a AI, Shaw A (2010) NDE system for the quality control of spot welding in the automotive industry. In: *SAS, IEEE*, pp 73–78
10. Wang X, Zhang H, Song J (2009) Multi-objective decision-making and combination evaluation of green manufacturing enterprises. In: *ICIMIMIE, IEEE*, pp 631–634

# Chapter 21

## Design of a New Electrohydraulic Control System for Segment Rotational Motion

Xu Yang, Guofang Gong, Weiqiang Wu and Yunyi Rao

**Abstract** In order to achieve high-speed and high-precision rotation positioning of segment, a new electrohydraulic control system is designed. Thorough mechanism analysis is firstly carried out to provide guidance for the design of electrohydraulic system. Then the designed system is analyzed by system modeling, based on which a suitable control strategy is proposed. Finally, both the electrohydraulic system and its control strategy are tested under simulated load in AMEsim platform. The results show that new electrohydraulic control system can achieve good performance in both speed control and position control. Therefore, this new electrohydraulic control system is useful and practical.

**Keywords** Rotation positioning · Electrohydraulic system · Control strategy · AMEsim platform

### 21.1 Introduction

Shield tunnel boring machine (Shield TBM) is a large engineering machinery, which has been widely used in urban tunnel due to its minimal ground movement [1–4]. It can achieve continuous tunnel excavation and support through four subsystems such as cutterhead system, propulsion system, screw conveyor system, and segment assembling system. Among them, the segment assembling system is located in the tail of Shield TBM, responsible for supporting the tunnel through pipe installation. Yet the accuracy of pipe installation will directly affect the support strength and sealing performance of tunnel wall [5, 6]. Besides, faster

---

X. Yang (✉) · G. Gong (✉) · W. Wu · Y. Rao  
State Key Laboratory of Fluid Power and Control, Zhejiang University, Hangzhou, China  
e-mail: yangxu256@163.com

G. Gong  
e-mail: gfgong@zju.edu.cn

installation will be beneficial to reduce the construction cycle. Thus, an accurate and efficient segment assembling system is desperately needed.

Generally, the segment assembling system is a 6-DOF platform, which could complete segment position control and segment attitude adjustment. As part of the segment position control, the rotary position control which is usually driven by an electrohydraulic system is one of the most difficult issues for segment assembling system due to its large load and long journey. Consequently, the rotary electrohydraulic control system is one of the key technologies to achieve accurate and efficient segment assembling.

In this paper, a new rotary electrohydraulic system is introduced to drive the segment rotary motion. Based on this electrohydraulic system, a real-time speed control strategy is also proposed to control the rotary velocity and rotary position of segment. Finally, a speed control simulation of the electrohydraulic control system demonstrates the applicability of this system.

## 21.2 Mechanism Analyses

Segment assembling system is an electrohydraulic control-based serial robot, which mainly includes swing mechanism, lifting mechanism, horizontal mechanism, and attitude mechanism, as is shown in Fig. 21.1. Loaded with the segment and other three mechanisms, the swing mechanism is mainly responsible for segment circular rotation. Thus, the key technology of designing a segment rotary driving system is to solve the problem of inaccurate positioning caused by large inertia load and long journey.

## 21.3 Design and Modeling of the Electrohydraulic Control System

### 21.3.1 System Design

Based on previous mechanism analysis, a new electrohydraulic control system (which controls the rotary motion by adjusting the load flow) is introduced, as is shown in Fig. 21.2.

The constant pressure oil source is provided by a fixed displacement pump and a relief valve, which could be discharged by a solenoid directional valve. The directional valve could also control the oil flow direction by changing spool position. Actuated by the pressure oil from one direction, the hydraulic motor drives the swing mechanism at a specific speed (which can be adjusted by the

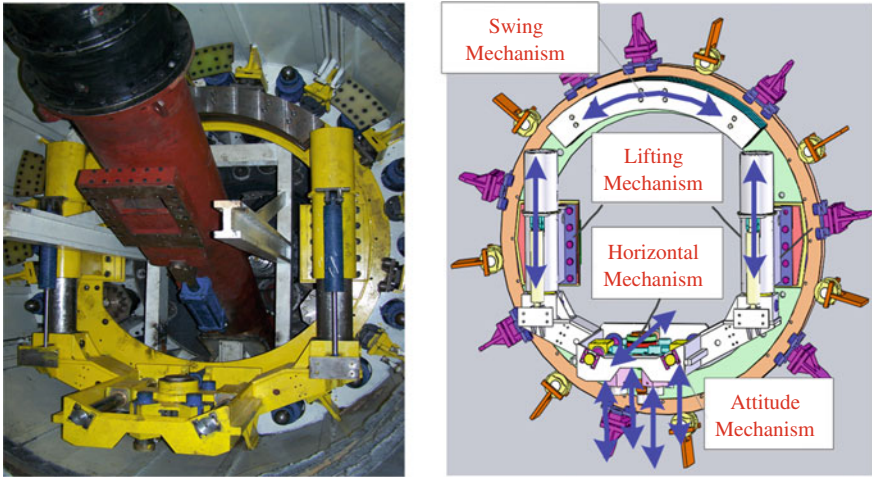


Fig. 21.1 Φ3 m segment assembling system

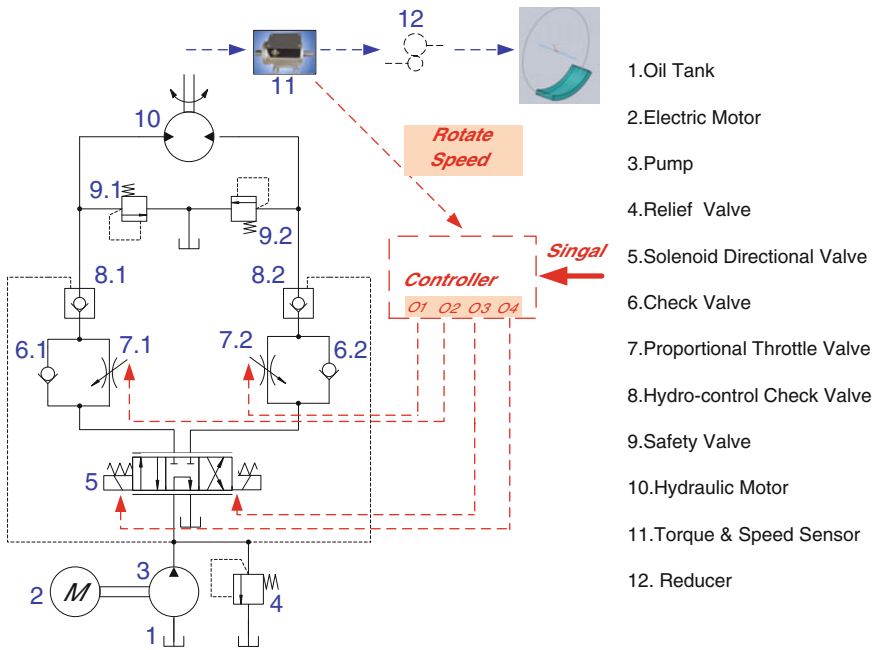


Fig. 21.2 New electrohydraulic control system for segment rotational motion

proportional throttle valve). The actual torque and speed could be measured by a torque and speed sensor. Besides, two hydro-control check valves are used to keep the swing mechanism from moving caused by leakage.



### 21.3.2 System Modeling

The torque balance equation of hydraulic motor can be expressed as follows:

$$(p_1 - p_2) \cdot \frac{D_m}{2 \cdot \pi} = J \cdot \frac{d^2\theta}{dt^2} + B_m \cdot \frac{d\theta}{dt} + T_L \quad (21.1)$$

where  $p_1$  is the active pressure of hydraulic motor,  $p_2$  is the passive pressure of hydraulic motor,  $D_m$  is the hydraulic motor displacement,  $J$  is the equivalent rotary inertia of swing mechanism,  $\theta$  is the rotation angle of hydraulic motor,  $B_m$  is the viscous damping coefficient of hydraulic motor, and  $T_L$  is the equivalent external load of swing mechanism.

The flow output of proportional throttle valve can be expressed as follows:

$$Q = C_v \cdot x_v \cdot \sqrt{p_2} \quad (21.2)$$

where  $C_v$  is the flow gain of proportional throttle valve,  $x_v$  is the opening size of proportional throttle valve.

The flow continuity equation in the passive pressure vessel of hydraulic motor can be expressed as follows:

$$\frac{D_m}{2 \cdot \pi} \cdot \frac{d\theta}{dt} + C_i \cdot (p_1 - p_2) = Q + C_o \cdot p_2 + \frac{V}{\beta_e} \cdot \frac{dp_2}{dt} \quad (21.3)$$

where  $C_i$  is the internal leakage coefficient of hydraulic motor,  $C_o$  is the external leakage coefficient of passive pressure vessel,  $V$  is the total volume of passive pressure vessel, and  $\beta_e$  is the oil elastic modulus.

### 21.3.3 Controller Design

Based on the hydraulic system model, a controller is designed which can be expressed as follows:

$$\begin{aligned} O_1 &= \begin{cases} 0 & \text{if(PID} > 0) \\ -\text{PID} & \text{if}(-1 < \text{PID} < 0) \\ 1 & \text{if(PID} < -1) \end{cases} \\ O_2 &= \begin{cases} 1 & \text{if(PID} > 1) \\ \text{PID} & \text{if}(0 < \text{PID} < 1) \\ 0 & \text{if(PID} < 0) \end{cases} \\ O_3 &= \begin{cases} 1 & \text{if(PID} > 0) \\ 0 & \text{else} \end{cases} \\ O_4 &= \begin{cases} 1 & \text{if(PID} < 0) \\ 0 & \text{else} \end{cases} \end{aligned} \quad (21.4)$$

$$PID = K_p \times e + K_i \times \int e dt + K_d \times \frac{de}{dt} \tag{21.5}$$

where  $O_1$  and  $O_2$  are analog outputs for two proportional throttle valve,  $O_3$  and  $O_4$  are digital outputs for the solenoid directional valve,  $e$  is the speed error of hydraulic motor,  $K_p$  is the proportion coefficient,  $K_i$  is the integral coefficient, and  $K_d$  is the differential coefficient.

### 21.4 Simulations and Discussion

To demonstrate the effectiveness of the electrohydraulic control system, a simulation model is constructed in AMESim platform, as is shown in Fig. 21.3. The inertia load and friction load are different between up and down, so two rotary loads are used to simulate the loads. And two different functions are applied to simulating the gravity load along the journey. Besides, for simplifying simulation model, two hydro-control check valves which have little impact on dynamic performance are omitted. Finally, the designed control strategy is added to the electrohydraulic system.

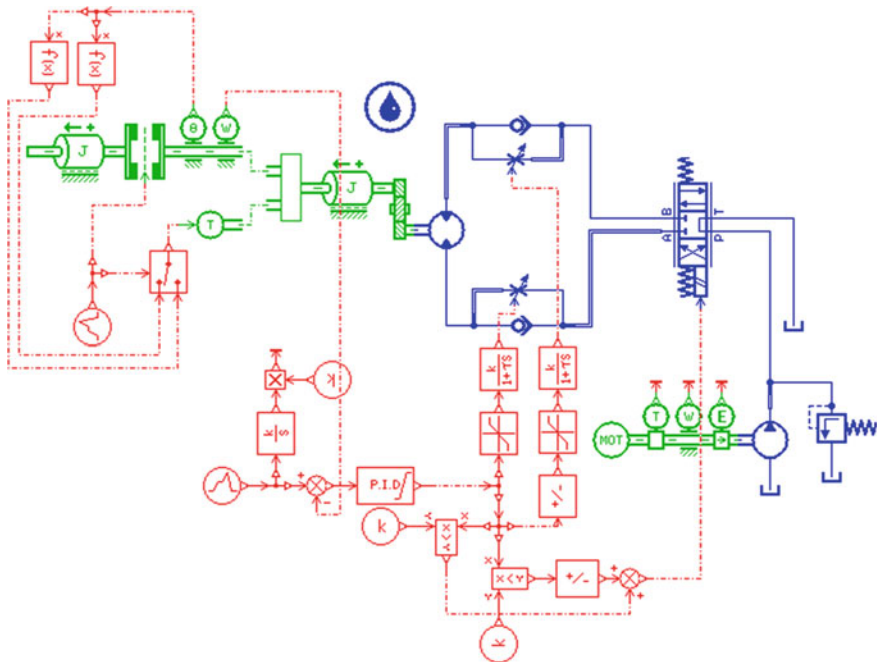
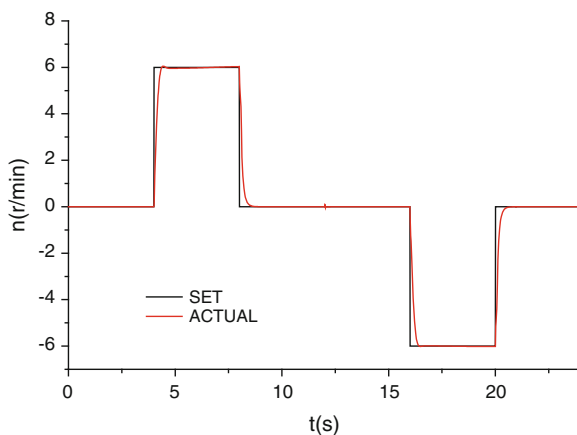
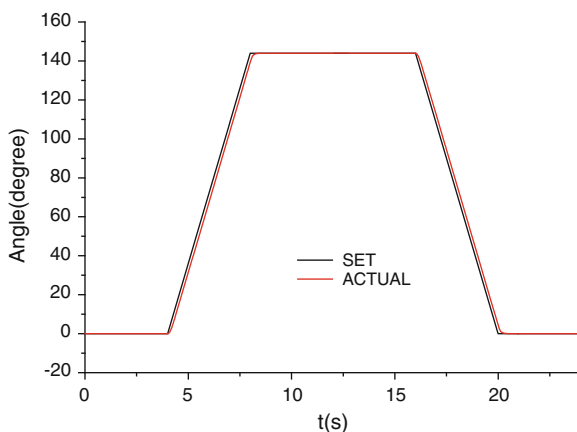


Fig. 21.3 Simplified simulation model of rotational electrohydraulic control system

**Fig. 21.4** Speed tracking performance



**Fig. 21.5** Position tracking performance



Based on the simulation model, a rotary motion test is carried out. The speed tracking performance can be seen in Fig. 21.4. The position tracking performance can be seen in Fig. 21.5.

## 21.5 Conclusions

A prior mechanism analysis provides scientific guidance for the design of rotary electrohydraulic system. And the model of the system points out that the new electrohydraulic system can not only keep the actuating pressure stable but also effectively control the rotation speed of hydraulic motor. Besides, the model-based control strategy can help to achieve high-speed and high-precision rotation positioning of segment, which is demonstrated by AMESim simulation. In the end, the energy efficiency of the system needs to be further improved.

**Acknowledgments** The research is funded by the National Basic Research Program of China (“973” Program) (Grant No. 2013CB035404) and the Science Fund for Creative Research Groups National Natural Science Foundation of China (51221004).

## References

1. Koyama Y (2003) Present status and technology of shield tunneling method in Japan. *Tunn Undergr Space Technol* 18(2):145–159
2. Kasper T, Meschke G (2006) On the influence of face pressure, grouting pressure and TBM design in soft ground tunnelling. *Tunn Undergr Space Technol* 21(2):160–171
3. Chi SY, Chern JC, Lin CC (2001) Optimized back-analysis for tunneling-induced ground movement using equivalent ground loss model. *Tunn Undergr Space Technol* 16(3):159–165
4. Liu XY, Shao C, Ma HF, Liu RX (2011) Optimal earth pressure balance control for shield tunneling based on LS-SVM and PSO. *Autom Constr* 20(4):321–327
5. Chen JS, Mo HH (2009) Numerical study on crack problems in segments of shield tunnel using finite element method. *Tunn Undergr Space Technol* 24(1):91–102
6. Mashimo H, Ishimura T (2003) Evaluation of the load on shield tunnel lining in gravel. *Tunn Undergr Space Technol* 18(2):233–241

# Chapter 22

## Ergonomics Research of EVA Handhold Cross-Sectional Dimensions

Yulin Xu, Changhua Jiang, Zheng Wang, Li Wang, Suying Yao  
and Chunhui Wang

**Abstract** Handhold is one of the important manual mobility aids in extravehicular activity (EVA). This paper is about the method and result of theoretical analysis and experimental tests of handhold cross-sectional dimensions. Ergonomics design indexes and their influential factors were put forward through theoretical analysis. The feasible range of width, thickness, perimeter, and ratio of width and thickness of handhold cross section were obtained through the gripping tests in pressed extravehicular mobility unit (EMU). Combining the results of theoretical analysis and experimental tests, the design-referenced value of handhold cross-sectional dimensions for engineering development was put forward finally.

**Keywords** Handhold · Cross section · Ergonomics

### 22.1 Introduction

Astronaut extravehicular activities are important ways to complete construction, maintenance, and various scientific experiments of the space stations. In the extravehicular activities, after the astronauts enter the outer space from the airlock door, they move to specified job sites by handholds laid on the bulkhead (Fig. 22.1). After completing the extravehicular operations, the astronauts need to take off foot restraints and stabilize the body posture by handholds around the operation places. Therefore, the design of the extravehicular handholds is very important for astronauts to complete extravehicular activities [1].

Ergonomics studies should be conducted to handholds for optimizing human-machine interface (HMI) of the handholds. According to the practical experience

---

Y. Xu (✉) · C. Jiang · Z. Wang · L. Wang · S. Yao · C. Wang  
National Key Laboratory of Human Factors Engineering, Astronaut Center of China,  
Beijing, China  
e-mail: xuyulin014@126.com



**Fig. 22.1** EVA astronaut moving on the surface of ESA cabin holding handhold

of handholds in the International Space Station and analysis of design data of American handholds, ergonomic designs of the handholds should include the handholds' length, spacing, distance between handholds and bulkheads, handholds' cross-sectional shape and size, etc. Thereinto, the cross-sectional dimensions of the handhold directly determine whether astronauts can effectively and comfortably grip handholds. This paper carried out ergonomics researches to the cross-sectional dimensions of the handholds by adopting theoretical analysis and experimental research methods.

## **22.2 Theoretical Analyses**

### ***22.2.1 Universal Ergonomic Design Principles of the Product HMI***

From the ergonomic view, the product HMI design should follow the following general principles [2]:

1. The product must effectively achieve the intended functions. Each structure or design point of products has its own meaning of existence, but the foremost goal is to achieve its functions.
2. Products should be in proper proportion with the user's body, so that the user can maximize efficiency.
3. Designs should be made according to the user's ability. Factors should be considered here including gender, age, anthropometric parameters,

kinematics and kinetics characteristics, familiarity to the product and product's use conditions, etc. The designers should determine specific design considerations according to products' use targets and environment, the target population, and use conditions.

4. Too much fatigue cannot be caused, and try to avoid static force.

### ***22.2.2 Ergonomic Design Analysis of Handhold Cross-Sectional Dimensions***

HMI between the product with the user includes the corresponding body parts' participation in product function and communication between the corresponding body parts and product forms. Therefore, the ergonomic design of the extravehicular handhold cross section can be summarized as astronaut hands' (wearing EVA gloves) participation in the gripping function of extravehicular activity (EVA) handhold and communication between hands and handhold cross section.

From the function analysis of EVA handholds, the operation of astronauts to the EVA handholds belongs to force grip, including gripping and releasing of handholds. EVA handholds should be easy and comfortable for astronauts' gripping and releasing wearing pressurized extravehicular mobility unit (EMU) and be unlikely to cause fatigue with long-time holding or continuous gripping and releasing.

According to the design data of EVA handhold published in NASA-STD-3001 (Fig. 22.2) that the cross-sectional width of the EVA handhold is 35 mm, the thickness is 16 mm. But these data are only for analysis and reference because of the differences between the USA EMU and Chinese EMU in the structure, pressure system and gloves flexibility. At present, most researches on the handholds at home focus in the civilian areas [3–5], which have bigger difference with operating conditions during extravehicular activities. Hence, only their research methods can be learned, and their data cannot be used directly.

The design data of Fig. 22.2 show that basic design factors of EVA handhold cross section include cross-sectional width and thickness dimensions. They are related with the dimensions of astronauts' hands (after the EVA gloves being pressurized) gripping objects. The gripping styles can be diverse when the astronauts actually grip the handhold, palm facing the surface (handhold surface) of handhold width and the surface of handhold thickness (handhold side). Therefore, the width and thickness of the handholds are required within the appropriate ranges.

Meanwhile, because of the high risk of EVA, the astronaut should put their security in the first place. According to the astronauts' flight experience, they need to firmly grip the handhold deliberately to feel whether they have gripped if the handhold is too thin (small perimeter). On the contrary, the astronaut's thumb cannot form a closed loop with their index and middle fingers if the handhold is too thick (large perimeter), so that they cannot feel gripping the handholds;

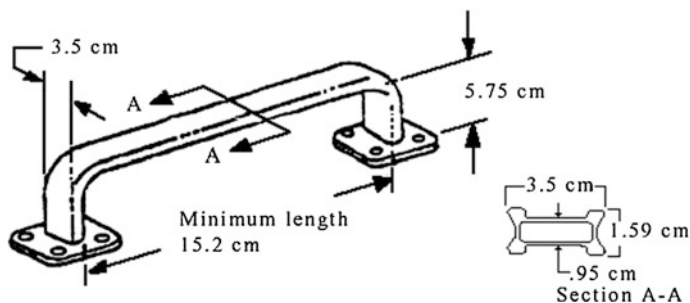


Fig. 22.2 Shuttle EVA handhold dimensions

moreover, they need to open their palms forcibly while they want to move to the next place. Therefore, the astronaut hopes that his thumb can form a closed loop with the index and middle fingers while holding the handholds. When the astronaut's thumb forms a closed loop with his middle and index fingers wearing pressured EMU gloves, perimeter of the closed loop is in a certain range. It can be used to determine the cross-sectional perimeter of the handhold.

Moreover, to increase the comfort of gripping and the function of keeping body stabilization, the width and thickness of the handhold cannot have much difference. If there are too much difference between the width and the thickness, the handhold cross section is close to the form of sheet, which induces the handhold being uneasy for gripping and with poor comfort. On the contrary, if they are too close, together with the chamfers conducted for security, cross section of the handhold is close to the circular, prone to rotate when gripping with poor body positioning performance. Therefore, when defining width and thickness of the handhold cross section, width-to-thickness ratio of the handhold cross section must be limited (i.e., width/thickness).

Combing with the above analysis, the ergonomic design specifications of EVA handhold cross section include the following: width, thickness, and perimeter and width–thickness ratio.

## 22.3 Researches on the EVA Handhold Cross-Sectional Dimension Experiment

### 22.3.1 Experimental Programme

The cross-sectional dimension gripping tests of EVA handhold are conducted in two rounds.

In the first round of tests, the upper, middle, and lower limits are set to the width and thickness of the handhold cross section, respectively, combining the foregoing analysis, size parameters of the hands of astronaut crowd, and handhold data being



preliminarily verified in the SZ-7 mission. Handholds in nine sizes have been made, as shown in Tables 22.1, where  $W$  represents the width of the handhold cross section,  $H$  represents the thickness, while the subscripts  $S$ ,  $M$ , and  $L$  represent the lower, middle, and upper limits, respectively. Appropriate size ranges for handhold cross-sectional width, thickness, and width–thickness ratio have been chosen through the first round of tests.

According to the results of the first round of tests (analysis procedures, see Sect. 22.3), handhold sizes for the second round of tests have been designed as shown in Table 22.2. According to the results of the second round of tests, detailed cross-sectional dimensions of the handholds were obtained, which can be directly applied to engineering development.

The test subjects were nine men. Because the tests involve only sizes of the hands, subjects with hand sizes within those of astronaut crowd can be chosen.

Before the test, the testers explain the different gripping style and testing precautions to the test objects in detail. During the tests, the testers hand out handholds with number sequentially to subjects, who do right-hand gripping, left-hand gripping, and both hands’ gripping for each handhold in turn. After handholds in the test have been completely gripped, handholds are ranked according to their gripping comfort. During the sorting process, supplement grip experience can be made according to the subjects’ requirements. After the test was completed, subjective feelings on grip were collected and recorded.

Subjects wear Fei–Tian EMU pressurized to 40 kPa during the test. Because the test subjects only need to move their wrists and fingers, there are no special

**Table 22.1** Cross-sectional dimensions of EVA handholds used in the first gripping test (mm)

No.	Width ( $W$ )	Thickness ( $H$ )	Perimeter
1	$W_s$	$H_s$	$2 \times (W_s + H_s)$
2	$W_s$	$H_M$	$2 \times (W_s + H_M)$
3	$W_s$	$H_L$	$2 \times (W_s + H_L)$
4	$W_M$	$H_s$	$2 \times (W_M + H_s)$
5	$W_M$	$H_M$	$2 \times (W_M + H_M)$
6	$W_M$	$H_L$	$2 \times (W_M + H_L)$
7	$W_L$	$H_s$	$2 \times (W_L + H_s)$
8	$W_L$	$H_M$	$2 \times (W_L + H_M)$
9	$W_L$	$H_L$	$2 \times (W_L + H_L)$

**Table 22.2** Cross-sectional dimensions of EVA handholds used in the second gripping test (mm)

No.	Width ( $W$ )	Thickness ( $H$ )	Perimeter
5	$W_M$	$H_M$	$2 \times (W_M + H_M)$
6	$W_M$	$H_L$	$2 \times (W_M + H_L)$
10	$(W_M + H_L) - [(H_M + H_L)/2]$	$(H_M + H_L)/2$	$2 \times (W_M + H_L)$
8	$W_L$	$H_M$	$2 \times (W_L + H_M)$

**Table 22.3** Results of the first EVA handhold gripping test

No.	Width ( $W$ )	Thickness ( $H$ )	Width–thickness ratio	Score	Rank
1	$W_s$	$H_s$	2	1.67	8
2	$W_s$	$H_M$	1.33	2.44	7
3	$W_s$	$H_L$	1	4.78	6
4	$W_M$	$H_s$	3	5.11	4
5	$W_M$	$H_M$	2	<b>6.89</b>	2
6	$W_M$	$H_L$	1.5	<b>6.89</b>	2
7	$W_L$	$H_s$	4	4.89	5
8	$W_L$	$H_M$	2.7	7	1
9	$W_L$	$H_L$	2	5.33	3

**Table 22.4** Results of the second EVA handhold gripping test

No.	Width ( $W$ )	Thickness ( $H$ )	Width–thickness ratio	Score	Rank
5	$W_M$	$H_M$	2	2.43	3
6	$W_M$	$H_L$	1.5	<b>3.00</b>	2
10	$(W_M + H_L) - [(H_M + H_L)/2]$	$(H_M + H_L)/2$	$\approx 2$	<b>3.14</b>	1
8	$W_L$	$H_M$	2.7	1.43	4

requirements on activity scope of rest of the body. Therefore, the EMU was placed in a special bracket dedicated for EMU during the test.

### 22.3.2 Experimental Result

In the first round of tests, the handhold with the top-ranked score was recorded as 9 points; the handhold ranked second being recorded as 8 points, and so on. Nine subjects' sorting results are counted according to this scoring method; the results of the first round of tests were in Table 22.3; the top three handholds were numbered 8, 5, and 6, respectively.

In the second round of tests, because there are only 4 sizes of handholds being sorted, the handhold ranked first was recorded as 4 points, the handhold ranked second being recorded as 3 points, and so on. The results of the second round of tests were shown in Table 22.4; the top two handholds were numbered 10 and 6, respectively.

### 22.3.3 Results Analysis and Discussion

#### 22.3.3.1 Analysis of Data from the First Round of Tests

As can be seen from Table 22.3, the first three handholds with highest comprehensive sorting scores are numbered 8, 5, and 6, respectively. These handholds' widths are between  $W_M$  and  $W_L$ , thickness between  $H_M$  and  $H_L$ , perimeter between  $2 \times (W_M + H_M)$  and  $2 \times (W_L + H_M)$ , and width–thickness ratio in the range of 1.5–2.7.

According to the observation of tester and subjective feeling descriptions of subjects, handholds' width changes abruptly between  $W_M$  and  $W_L$ , so an intermediate value between  $W_M$  and  $W_L$  should be set to test; an intermediate value for thickness should also be set between  $H_M$  and  $H_L$ . After analysis by combing the ranges of handholds' cross-sectional perimeter and width–thickness ratio, a new handhold (No. 10) was designed whose cross-sectional width is  $(W_M + H_L) - [(H_M + H_L)/2]$ , thickness being  $(H_M + H_L)/2$ , width–thickness ratio being 2, and handholds' perimeter being  $2 \times (W_M + H_L)$ . The No. 10 handhold plus the handholds ranked the top three in the first round of tests (numbered 5, 6, and 8); totally, four handholds were used in the second round of tests.

#### 22.3.3.2 Analysis of Data from the Second Round of Tests

According to results of the second round of tests given in Table 22.4, the top two handholds are numbered 6 and 10 with very close scoring, respectively, 3.14 and 3.00. The handhold ranked third is numbered 5 with scoring 2.43.

The top two handholds have cross-sectional perimeter  $2 \times (W_M + H_L)$ , with width range between  $W_M$  and  $\{(W_M + H_L) - [(H_M + H_L)/2]\}$ , thickness range between  $[(H_M + H_L)/2]$  and  $H_L$ , AND width–thickness ratio between 1.5 and 2.0.

To the handhold ranked third, the cross-sectional perimeter is  $2 \times (W_M + H_M)$ , width being  $W_M$ , thickness being  $H_M$ , and the width–thickness ratio being 1.5.

#### 22.3.3.3 Analysis Result

Through analysis of two rounds of test results, based on the technical state of domestic Fei–Tian EMU, the design reference values of EVA handhold cross-sectional dimensions were finally determined as follows: Perimeter is  $2 \times (W_M + H_L)$ , the width range is between  $W_M$  and  $\{(W_M + H_L) - [(H_M + H_L)/2]\}$ , the thickness range being  $[(H_M + H_L)/2] - H_L$ , and width–thickness ratio being 1.5–2.0.

## 22.4 Conclusions

Handholds are important auxiliary devices for astronauts to finish spacewalk and stabilizing their body postures in the EVAs. Therefore, scientific and rational designs for handholds will help astronauts to complete EVA tasks efficiently and conveniently.

This paper analyzes ergonomic design specifications and its influencing factors for the EVA handholds' cross-sectional dimensions, with the combination of foreign application experience and from the EVA handholds' use environment and work conditions plus of HMI with astronauts. According to astronaut crowd's hand sizes and the pretask data, and referring to foreign EVA handhold design data, handhold models with different cross-sectional dimensions have been made; two rounds of test researches have been carried out. Through the analysis of test data, the cross-sectional dimensional data of handholds have been obtained, which can be applied in the engineering development.

**Acknowledgments** This research work was funded by the National Key Basic Research and Development Program (973 program, No. 2011CB711000) and the autonomy research project of the Human-Factor Engineering Laboratory (No. HF12ZZB05).

## References

1. Zhang N, Tian YS, Xu H et al (2011) Classified statistics and analysis of astronauts' typical actions during extravehicular activity. *Space Med Med Eng* 24(5):366–368
2. Wang Y, Liu S (2011) Ergonomics design of handheld products. *Chin J Ergon* 17(2):52–55
3. Zhang Z, Zhu Y, Xia M (2012) An innovation human engineering experiment design of comfort of handheld products. *Exp Technol Manage* 29(11):78–81
4. Ye J, Li J (2010) Research and implementation of tool handle comfort level evaluation method. *J Mech Electr Eng* 27(1):62–64
5. Zhang L, Ma F, Zhuang G (2013) Research of chair EVA in Bus Light Industry. *Sci Technol* 177(8):57–58

**Part III**  
**Research on the Environment Character**

# Chapter 23

## Analysis on the Oxygen Flow Index of Special Vehicle Oxygen Generator

Yuping Luo, Yaofeng He, Guansheng Huang and Yajuan Bai

**Abstract** At high altitudes, in special vehicles equipped with oxygen-generating device, the fighting capacity of the crew can significantly improve. In the process of oxygen-making device development, whether oxygen flow meets the passenger demand has nagged the designer. The index is not only affect the oxygen plant energy consumption, volume and weight, the ways of oxygen inhalation, and directly affect the feasibility of oxygen generator column mounted. This paper combination of plateau environment has carried on the oxygen flow index from the high-altitude physiology angle. On the basis of respiratory physiology demand of personnel, it decided the pulmonary ventilation as oxygen flow design basis; according to the special vehicle measurement, defined the pulmonary ventilation of crew; according to the characteristics of special vehicles, with the physiological protection requirement of crew and engineering possibility, defined the oxygen supply strategy suitable; and the oxygen flow index was estimated, which meet the crew sea level, 1,500, 2,500 m altitude respiratory protection level of crew, providing reference for the further research on the performance index of the oxygen plant.

**Keywords** Pulmonary ventilation · Oxygen flow rate · Oxygen generator

### 23.1 Introduction

Nowadays, the development work for special vehicles plateau onboard oxygen generator has made some progress, to solve the problems whether there is oxygen supply equipment, but there are no indexes for reference to check whether the oxygen generator's performance indexes meet needs of the special vehicle

---

Y. Luo · Y. He · G. Huang (✉) · Y. Bai  
Beijing Special Vehicle Institute, Beijing 100072, China  
e-mail: rx051610@163.com

occupants. Studies on the influence degree of different oxygen flow to the occupants' physiological parameters and operating performance are still blank; the basic researches are relatively weak. This paper combines the plateau environment and characteristics of special vehicles, discusses indexes for oxygen supply flow of the onboard oxygen generator from the plateau physiological angle, and provides the best strategies for the onboard oxygen generator.

## **23.2 Basis of Respiratory Physiological Requirements [1, 2]**

Crews' demands for the oxygen is the basis and foundation for the development of the oxygen generator; research and analysis of the respiratory needs of special vehicle occupants in the plateau conditions are the basis for engineering design.

Processes between humans and the environment and within the human body are called respiration. Whole respiratory process consists of three interrelated links, including (a) external respiration, which means gas exchange between blood and the external environment in the lungs, including lung ventilation and pulmonary ventilation (gas exchange between alveolar and blood); (b) gas transport in the blood; and (c) internal respiration, referring to gas exchange between blood or tissue fluid and tissue cells.

Pulmonary ventilation is the process for gas exchange between the lung and the outside, namely outside fresh air enters into the lungs and exhaust gas in lungs is discharged to the outside.

### **1. Lung capacity**

Lung capacity is gas capacity accommodated in the lung. Lung capacity is changed along with amount of gas in and out of the lungs during the breathing movement. Measuring lung capacity helps to know conditions of the lung ventilation. Lung capacity is divided into the following components.

#### **(a) Tidal volume (VT)**

Inhaled or exhaled gas during each quiet breathing is called VT. VT of normal adults is about 400–500 ml.

#### **(b) Vital capacity (VC)**

VC is the gas, which can be exhaled after the maximum inspiratory breath and then trying to exhale. For normal adults, the lung capacity mean of men is 3.47 L and that of women is 2.44 L.

#### **(c) Residual gas volume**

The gas volume remaining in the lungs at the end of expiration is called the residual gas volume. Healthy adult male has an average residual gas volume of 1.53 L.

#### **(d) Total lung capacity**

The largest volume of gas which can be accommodated in the lung is called total lung capacity, namely the sum of VC and residual gas volume. Healthy adult male has total lung capacity of 3.61–9.41 L.

## 2. Pulmonary ventilation

Pulmonary ventilation refers to amount of gas, which is breathed into and out of the lungs. Compared with the lung volume, pulmonary ventilation can better reflect the pulmonary ventilation functions.

The total amount of gas breathed into or out of the lungs per minute is called ventilation per minute, and the value equals to VT multiplied by the respiratory frequency. The average breathing frequency of human when they are in quiet state varies with age; normal adults' breathing frequency is about 12–18 b/min. Respiratory frequency and VT are changed along with the body's metabolic rate, both of which are increased while metabolism is increased. When adults' ventilation per minute in quiet state is about 6–8 L, while engaged in heavy labor or strenuous exercise, it rises up to 70 L above.

Pulmonary ventilation can change by adapting to the needs of a variety of physiological changes, such as mental stress, increase of physical strength, and increasing altitude. Generally, when a healthy young adult does strenuous exercise, VT can be increased from 500 to 2,000 ml, respiratory frequency can be increased from 12 to 18 to 50 b/min, and the pulmonary ventilation is enlarged several tenfold. Pulmonary ventilation demands of occupants is the design basis of oxygen supply system installed in the special vehicle.

## 23.3 Determination of Pulmonary Ventilation of Special Vehicle Occupant

The oxygen demand of the body refers the amount of oxygen required in the unit time for metabolism, also called oxygen consumption. Because there are different functional status of the body and metabolism, oxygen consumption is also different.

Large numbers of studies show that the human bodies' oxygen consumption is proportional to and labor intensity, larger the labor intensity, greater the oxygen consumption.

When occupants carry out training tasks, they can be divided into in mild, moderate, and heavy labor according to the labor intensity. Oxygen consumption also varies correspondingly. Oxygen consumption of special vehicle occupants was measured when they do water operations; the results show the occupants' minimum oxygen consumption is 354.6 ml/min/person, and the peak value is 761.3 ml/min/person.

Based on GJB1336-92 "Strength Grading for Military Physical Labor" [3], pulmonary ventilation can be calculated based on oxygen consumption. Pulmonary ventilation calculated by the need to complete the job is 14–20 L/min/person.



Oxygen consumption of the occupants has not been measured in the plateau region. Occupants' physical load increases along with increasing altitude; lung ventilation needed to complete the job increases correspondingly.

### 23.4 Determination of Oxygen Flow of Onboard Oxygen Generator

When determining oxygen flow indexes of the onboard oxygen generator, the following factors should be considered:

1. Physiological protection level of occupants.

The human alveolar oxygen partial pressure drops along with increasing altitude and decreasing atmospheric pressure. By supplementing high concentration of oxygen, the reduced inhaled oxygen partial pressure can be compensated, which is caused by the reduction of the atmospheric pressure. If human alveolar oxygen partial pressure level is very close by supplying oxygen, when staying in two different atmospheres, they can be considered equivalent if judging from their effect of oxygen supply to the body. For example, when breathing oxygen in high density at sea level altitude of 4,000 m, if human alveolar oxygen partial pressure level is close to that of breathing in the sea level, it deems the body has physiological protection degree at sea level.

Professor Jia Siguang determined the boundary heights of six kinds of physiological protection, based on the influence of different degrees of acute hypoxia on the human body (without hypoxic acclimatization) [4].

- (a) Best value: sea level.
- (b) Security value for night flight: 1,500 m, which is physiological limit value to ensure normal vision during night flight.
- (c) Value to guarantee efficiency: 2,500 m, which is physical boundaries to ensure the effectiveness of daytime flight crew is not being reduced.
- (d) Efficacy allowance values: 4,000 m, mild hypoxia response is allowed, but physiological limit values are not significantly influenced on the efficacy.
- (e) Hypoxia tolerance limits: 5,000 m, hypoxia response is obvious, the initial physiological limit values difficult to withstand.
- (f) Hypoxia limits: 7,500 m, the physiological limit value causing consciousness.

Whether the amount of oxygen respiration meets breathe protection can be judged according to the need of vehicle tactical technology; the level is 1,500 or 2,500 m.

2. Possibility of engineering implementation.

Special vehicle's interior space is small, oxygen generator with large oxygen flow is bound to take up too much space, so it is not realistic to use oxygen generator in the special vehicles, and the feasibility should be considered properly.

Oxygen flow indicators cannot be put forward fully in accordance with the ideal physiological requirements.

It is suggested to increase the oxygen-mixing tank at the oxygen output terminal; the high-concentration oxygen gas generated by oxygen devices is mixed with the environmental gas by mixing means, so that the oxygen concentration reaches the level of protection to meet the occupants' physiological needs and save partial oxygen.

Moreover, oxygen supply can be divided into persistent and intermittent oxygen supplies according to the oxygen supply demands. Continuing oxygen supply is the oxygen supply for a long time, generally in conditions that the oxygen source is enough or serious personal hypoxia, medical oxygen supply often adopts this means. The intermittent oxygen is adopted for insufficient oxygen source supply; occupants take oxygen in turn; its performance to improve the body is also obvious [5].

The author did rough estimation to the oxygen flow needed by every person; when using molecular sieve oxygen generator (oxygen generation concentration is 56.6 %) at an altitude of 4,000 m, crew pulmonary ventilation is 20 L/min/person; gas mixing tank is required to be equipped at the oxygen output end of the oxygen generator. Oxygen is output by the oxygen regulator, adopting oxygen persistent supply means, and the required oxygen flow per person is as follows:

To meet the crew's physiological protection level at sea level, oxygen plant flow is 10.4 L/min/person;

To meet the crew's physiological protection level in the height 1,500 m, oxygen plant flow is 7.6 L/min/person.

To meet the crew's physiological protection level in the height 2,500 m, oxygen plant flow is 6 L/min/person.

Considering constraints in the special vehicle interior space and energy, oxygen generators to meet the above indexes are not easy to achieve; it is suggested to take a intermittent oxygen supply mode; occupants take oxygen in turn; the total oxygen amount can be halved or reduced to 1/4.

## References

1. Chen X, Yuan X (1995) Man-machine-environment system engineering physiology basis. Astronautics Press, Beiing University of Aeronautics
2. Xiao H (2003) Physiology of oxygen protective equipment. Military Medical Science Press, Beijing
3. GJB1336-92 Classification of labor intensity military strength
4. GJB114-86 Acute hypoxia protective physiological needs
5. Wu S, Luo Y (2003) Discussion on the oxygen supply problem, that enclosed mask type in plateau area. Progress in man-machine-environment system engineering research volume 6. Ocean Press

# Chapter 24

## Technology of Waste Disposal in Long-Term Manned Spacecraft

Lantao Zhang, Chuanfeng Wei, Wencheng Luo and Fanlu Bai

**Abstract** During the manned spaceflight, large amount of waste will be produced due to the daily activities of astronauts. The waste is usually collected and then brought back to the ground in the short-term spaceflight. In the future missions of long-term manned spacecraft, the astronauts will spend much longer time in the spacecraft, in which much more waste will generate. If the waste is not properly handled, the quality of astronauts' life and space missions will be seriously affected. Therefore, the waste disposal technology is a new challenge for the space station in the future. In this paper, the waste disposal technology in the long-term manned spacecraft is analyzed in detail. According to the source of the wastes, in the end, some suggestions are proposed on waste disposal techniques for the Chinese space station.

**Keywords** Long-term manned spacecraft · Waste disposal

### 24.1 Introduction

During the long-term manned spaceflight, large amount of waste will be produced. If these wastes simply discharged into outer space, which will become space junk on high speed near the spacecraft orbit, then, the spacecraft will face a serious security threat. Therefore, these wastes need to be processed in the cabin. However, the room of the cabin is so limited, and how to effectively complete the disposal of waste in the cabin has become an important and urgent problem.

---

L. Zhang (✉) · C. Wei · W. Luo · F. Bai  
Institute of Manned Space System Engineering, CAST, Beijing 100094, China  
e-mail: zlt840208@163.com.cn

## 24.2 Source of Waste

The wastes generated during the flight can be broadly divided into three categories, which are daily activities, repair and maintenances, and the experiments. Specific types of waste are shown as below, respectively [1] (Fig. 24.1).

The waste of daily activities mainly includes food, clothes, personal hygiene, exercise, medical monitoring, etc., according to NASA space center experiences from the International Space Station (ISS), of the volume of all the wastes, food containers accounted for 85 % and food scraps and personal hygiene products accounted for 7 and 3 %, respectively. From the data above, the volume of the waste of daily activities accounted for the major part of all the solid waste [1].

In order to keep much longer time in the spacecraft, the wastes generated from the experiments, including experimental units, discarded gas, and liquid, which involve biology, chemistry, and physics, need to be harmlessly disposed.

As the spacecraft operates for a long time in flight, it needs repair and maintenances for hardware, which includes external and internal devices, so that the replacements of the hardware become a major source of wastes, especially in the latter phase of the spacecraft operation, and the proportion will increase gradually.

## 24.3 Classification of Waste

According to demanding of astronauts in the long-term manned spacecraft, the types of wastes are similar to those on the ground. The following classifications are on the basis of characteristics of the wastes, and the hazard levels are proposed (Table 24.1).

## 24.4 Analysis of Disposal Technology

According to the hazard levels of wastes, the disposal methods and difficulties are relatively different. The wastes on high hazard level should consider in prior both in terms of disposal and destruction. The technology of waste disposal is analyzed in the following part according to hazard levels.

### 24.4.1 Hazard Level 4

The hazard level 4 means the harm is intolerable; the wastes can cause serious harm to the body tissue, which mainly involve the wet wastes, radiation, sharp objects, and so on.

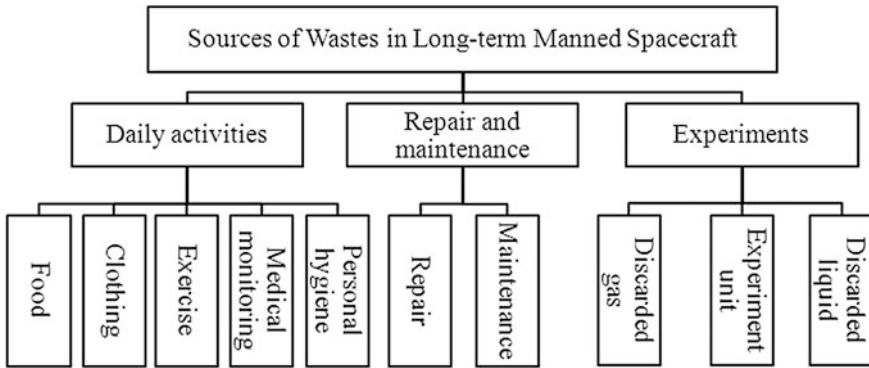


Fig. 24.1 The sources of wastes in long-term manned spacecraft

Table 24.1 Characteristics and hazard level of wastes

Types of wastes	Characteristics of wastes	Hazard level ※
Battery	Batteries (such as nickel–chromium, lithium, alkaline batteries, etc.,)	2
Biology, medicine	Medical monitoring samples (such as blood, saliva, urine, etc.), easy to breed bacteria	4
Sharp objects	(Broken glass and plastic products, scalpels), easy to damage the skin	4
Chemical hazards	Spilled chemical reagents, easy to react with each other	3
Radioactive materials	( $\gamma$ radiation etc.,). Inducing human tumors	4
Repair and maintenance	Various shapes without biohazard	0
Daily activities	Dry categories: free of water (such as paper, package, plastics, etc)	1
	Wet categories: rich in water and nutrients, easy to breed microorganisms (such as metabolites, food scraps, etc)	4
※: Hazard level	0. No harm	
	1. Critical hazard	
	2. Severe physical harmful exposure	
	3. Tolerable and serious harm to the body tissues	
	4. Intolerable and serious harm or contact with body tissue	

The wet wastes, such as food scraps and stool, contain large amounts of water and nutrients, which are so beneficial to the growth of bacteria. If not disposed properly, these wastes would not only bring the smelly odor inside the spacecraft, but also diseases to astronauts, so that these require adding preservative to prevent

the growth of bacteria and using the vacuum technology to keep the packages entirely sealed. For low temperature can inhibit the growth of bacteria, the packages can be stored in the low-temperature regions as far as possible.

Due to the microgravity environment, the sharp waste, such as needles, broken glasses, and others, would be floating in the cabin if not collected, these can make astronauts get hurt [2], so that a hard shell case would be used.

The radiation waste, such as  $\gamma$  source radiation, would bring long-term radiation in the cabin if not treated, which can cause the body cancer and other chronic diseases. In order to against the severe damage, radioactive waste should be collected in the radiation-proof containers, such as lead box. For the storage, the wastes should be placed in areas seldom visited [2].

On account of the severe effects on human health, the astronauts should dispose the wastes of this hazard level with cautions and destruct them in high priority.

### ***24.4.2 Hazard Level 3***

The waste of hazard level 3, which mainly relates to chemicals and biomedical, etc., can be tolerated or can cause serious harm to the body tissues.

Chemical wastes are produced on the processes of experiments in the cabin, such as benzene, CO, and other harmful chemical substances. These chemicals can react with each other and produce new unpredictable gases. Therefore, this type of wastes should be stored each in different sealed cans to prevent the secondary chemical reactions and then mark the information on the label of the cans [3]. However, the wastes, which are compatible with others, can also be stored in the same sealed container. On the other hand, it is good for economizing the resources of spacecraft.

Another type of wastes of hazard level 3 mainly generates from the astronauts' medical care in flight, such as blood, sputum, urine samples, etc., which can provide nutrients for the microorganisms to make astronauts get cross-contaminated. With an environmental difference from ground, we cannot use the autoclaving method in the space and the amount of such wastes is small, so that these wastes can be collected by double-sealed bags with moisture-proof design, which are added disinfectants and antibacterial agents before use, then the wastes should be kept in the low-temperature areas [3, 4].

### ***24.4.3 Hazard Level 2***

Hazard level 2 means the wastes can cause severe physical harmful exposure. These wastes mainly involve various types of discarded batteries. If these wastes were generated, the astronauts need to check the integrity of the batteries first in case of the electrolyte leakage, because the leaked liquid would be floating in

microgravity environment, which can cause skin allergy if the astronauts contacted, even get into the eyes, which would cause blindness. Thus, the batteries should be wrapped with plastic film covering to prevent leakage. Then, put the same type of batteries in a zipper bag [4], so that the collision between different types of batteries can be avoided, if the batteries were short circuited.

#### ***24.4.4 Hazard Level 1***

Hazard level 1 means the wastes can cause critical damages. Generally, this type of wastes is harmless, and only under some circumstances, they can turn to a minor hazard. These wastes mainly include spare parts for repair and maintenance. Though they have various shapes and contaminated surface, these wastes have no biomedical hazard, so this type can be directly put into the new spare parts package without sealing. As the spacecraft repair and maintenance mainly occurs in the late operation of long-term spacecrafts, therefore, we should put emphasis on the storage of these wastes in the late period.

#### ***24.4.5 Hazard Level 0***

Hazard level 0 means harmless. This type of wastes include dry wastes that are little moisture, such as paper, package, plastics, etc., these wastes are characterized by large quantities in the daily life, and the volume after use is significantly higher than before. For the limited space of the spacecraft, the volume compression method should be considered to dispose such type of wastes.

### **24.5 Conclusions**

In conclusion, the source and characteristics of the waste are discussed in the long-term manned spacecraft. According to the hazard level to astronauts and spacecrafts, the disposal technology of different types of wastes is analyzed, and corresponding suggestions, such as sealed, compressed, and special containers, are proposed in the article, which can be considered in the design of Chinese space station in the future.

## References

1. Richard S Williams (2001) Human factors, habitability, and environmental health NASA-STD-3001. vol 2
2. Hison et al (1980) The disposal of nuclear waste: the space option spaceflight. vol 22(4)
3. Anderson et al (1988) Space station integrated refuse management system NASA-CR pp i-xi
4. Andrew JP(1993) Space station trash removal system United States Patent. Patent Number: 5242134



# Chapter 25

## Analysis of the Mold Resistance of the Non-metal Materials on Space Station and Suggestions of Improvement Measures

Fanlu Bai, Chuanfeng Wei and Lantao Zhang

**Abstract** The space station and other long-term manned spacecrafts will experience the risk of microbial corrosion, especially mold, which will be harmful to the platform system and astronauts. This paper tests the mold resistance level of several frequently used non-metal materials in the pressured cabins of the space station. The results show that the mold resistance level of most materials is 0–1, which satisfies the anti-mildew requirements, but the mold resistance level of some materials is 2–4, which indicates the surfaces of such materials are overgrown with fungi, which may cause disruptions of equipment and even failure of missions. We discuss the reason why some materials does not meet the mold resistance level and propose the anti-mildew methods of these materials, including adding inorganic, composite, and natural anti-mildew components to process materials, and more-over utilize nanotechnologies on the surface treatment of several materials.

**Keywords** Mold resistance · Non-metal materials · Anti-mildew methods · Space station

### 25.1 Introduction

We have already successfully launched several manned Shenzhou spacecrafts and Tiangong-1 spacecraft and completed short- and mid-term manned spaceflights. In order to support onboard residence, it is necessary to produce a hospitable environment for human in the pressured volume, but it is also a good environment for the in-orbit microbes to grow, which brings potential safety hazards to the astronauts [1]. Tiangong-1 and the manned spacecrafts have only processed short- and mid-term manned spaceflights, and the growth of the microbes did not cause

---

F. Bai (✉) · C. Wei · L. Zhang  
China Academy of Space Technology, Beijing, China  
e-mail: baifanlu@sina.com

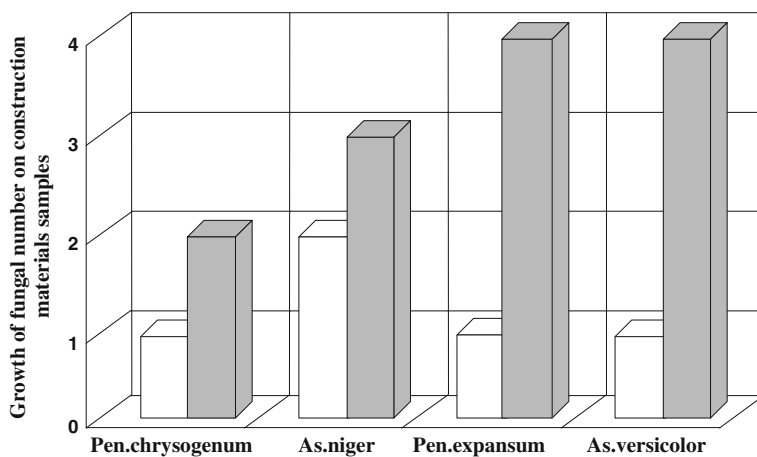
serious problems. However, for the long-term manned spaceflights, such as the space station whose lifetime is more than 10 years, the impact of microbe contamination cannot be ignored. The microbial problem is a new challenge for the space station's long-term operation.

According to the manned space experience of Russia and USA, the mass propagation of microbes in the Mir Space Station, the International Space Station (ISS), and other long-term spacecrafts has brought many problems.

Mir had been operating in orbit for 15 years, and 58 kinds of bacteria and 36 kinds of fungi were found in the pressured cabin, which caused problems to the equipment and spacecraft structure [2]. ISS is the biggest manned spacecraft ever since, and it has been operating for 15 years in orbit. Until now, 82 kinds of microbes are found in the ISS, including 18 genera—48 species of bacteria and 12 genera—34 species of fungi [3].

In addition, according to the research of State Scientific Center of Russian Federation, the aggressiveness of the in-orbit microbes to the materials is much stronger than it of the homologous microbes on the ground. From the Fig. 25.1 below, it can be seen that the growth speed of fungi in the ISS is much quicker than it on the ground, which means the biodegrading activity of the fungi to the materials will become larger in orbit.

After successfully completing the Shenzhou spacecrafts, the Tiangong-1 spacecraft, and other short- and mid-term manned spaceflights, we are conducting the research and development of China's space station, which will operate in orbit for long term. In order to prevent the harms of the in-orbit microbes and decrease the secondary pollution of the disinfectant to the pressured volume, it is necessary to evaluate the mold resistance level of the materials, select those not favorable for microbial growth, and use antimicrobial materials in the preflight period.



**Fig. 25.1** Comparison of the fungi's growth on construction materials in the ISS and on the ground. [2]

This paper introduces the mold resistance tests of the frequently used non-metal materials, analyzes the results of the anti-mildew level, and proposes the suggestion for the anti-mildew methods of the materials according to the characteristics of the materials in the space station.

## 25.2 Test Methods of Material Mold Resistance

### 25.2.1 Test Materials

The frequently used materials in the space station are divided into carbon fiber, glass fiber composites, fabric, decorative materials, thermal insulation material, anodized surfaces, cable connector, and other categories. According to the above classification, this experiment chooses 46 kinds non-metal materials to conduct the mold resistance tests on the ground.

### 25.2.2 Test Strains

According to the dominant molds separated from the pressured volume, this paper studies 5 kinds of molds with high corrodibility as the test stain to conduct the mold resistance test on the ground (Table 25.1).

### 25.2.3 Test Procedure

- From this experiment, we eluted purified fungal spores with tween 80 and put spore suspension in the thermostatic shaker to oscillate and separate. Then, we used high-speed centrifuge to precipitate and separate spores and diluted the solution with inorganic salt. Then, we adjusted the concentration of the spore suspension to  $1.0 \times 10^6 \pm 2.0 \times 10^5$  per milliliter through optical microscope (CX41 produced by Olympus).

**Table 25.1** Test strain in the mold resistance test

Code	Strain name	Strain number
1	<i>Aspergillus niger</i>	AS3.3928
2	<i>Aspergillus flavus</i>	AS3.3950
3	<i>Aspergillus versicolor</i>	AS3.3885
4	<i>Penicillium funiculosum</i>	AS3.3875
5	<i>Ball chaetomium</i>	AS3.4254

- In order to check the activity of spore, we took quantitative single spore suspension onto the Potato Dextrose Agar (PDA) panel to cultivate at the temperature of 29 °C for 7 days.
- We pretreated the tested materials and control samples under the temperature of 30 °C and relative humidity of 95 % for 4 h with MJ-160BS-III mold incubator produced by BOXUN Company. We made the target spore suspension by blending all sorts of single suspension together at the same volume and then sprayed the suspension onto the surface of tested materials and control sample. Make sure that composite spores have full contact with the materials.
- The temperature of the test chamber (incubator) was around  $30 \pm 1$  °C, the relative humidity was around  $90 \pm 5$  %, and the materials were exposed for 28 days [4].

Other requirements in the process of experiment should refer to the National Military Standard.

### 25.3 Test Results and Analysis

According to the National Military Standard (GJB150.10A-2009), the anti-mold levels of the tested materials are determined, as listed in the following table (Table 25.2).

The table above shows that most of test materials are given the level of 0–1, which means they can meet the anti-mildew requirement. We can also see that sealing rubber, decorative material, plastic, and resin and textile fiber do not meet the anti-mildew requirement. Among them, both sealing rubber and textile fiber are found to be extremely susceptible to fungal colonization, which can lead to microbial contamination on the surface of material more easily.

All of these materials belong to organic macromolecular compounds, which have hygroscopic moisture, sensitive chemical group, low crystallinity, low molar mass, high linear degree of molecular chain, and larger surface area. The rich nutrients inside the material contribute the growth and reproduction of microorganisms [5], for the following reasons:

**Table 25.2** Mold resistance level of the 46 kinds of test materials

Code	Material	Level
1	Sealing rubber (1 kind)	4
2	Decorative material (2 kinds)	2
3	Plastic and resin (1 kind)	1–2
4	Fiber material (1 kind)	4
5	Other materials (41 kinds)	0–1

- It contains amounts of additive made of small molecules, which contributes to the growth of microorganisms.
- It contains rich carbon skeleton structure. Microorganisms can degrade polymers by breaking chemical bonds through enzymatic hydrolysis to obtain nutrition.
- Textile fiber could be highly absorbent due to its porous structure that can contribute to active growth and reproduction of microorganisms.

## 25.4 Suggestions on Anti-mildew Methods

From the results above, several materials cannot meet the mold resistance requirement in the pressured cabins of the space station. However, the utilization of these materials is inevitable in the space station for a long time. Therefore, in order to ensure the safety of the equipment and astronauts in orbit, mold resistance methods should be taken on the ground.

In the present, most of the anti-bacteria and anti-mildew materials are made by adding antimicrobial additives, which include inorganic, organic, and natural agents. The major mechanisms of controlling the microbes are protein denaturation and genetic interference [6]. For the special environment characteristics of the space station, some suggestions are proposed on the material surface treatment methods.

- For the materials in the close contact area, inorganic antimicrobial additives can be used to achieve the microbial control through active oxygen and slow release of metal ions. These inorganic additives are divided into the three categories: metal ions additives ( $\text{Ag}^+$ ,  $\text{Zn}^{2+}$ , and  $\text{Cu}^{2+}$ ), active oxide additive ( $\text{ZnO}$ ,  $\text{MgO}$ , and  $\text{CaO}$ ), and photocatalytic additive ( $\text{TiO}_2$ ) [7]. They have broad spectrum, high safety, and long effectiveness, but they may not be so effective for the mold with strong survival abilities.
- For the materials used in the regions that are inconvenient to clean, some organic components, such as quaternary ammonium salt, are considered to be added in addition to the inorganic additives to improve the anti-mildew ability and avoid mass propagation of microbes [8].
- For the regions that are hard to reach, antimicrobial nanotechnology is considered to be used. Inorganic antimicrobial additives are produced in the nanosize and coated on the surface of the material through vacuum coating to increase the surface area and reactivity and eventually increase the antimicrobial ability. Based on the characteristics of long effectiveness, high resistance, and high stability, this method can decrease the effect to the electrical and optical properties of base material surface since the material thickness is at nanolevel. Astronauts should avoid direct contact with these nanomaterials that can be easily absorbed by human.

- For the fabric materials, we can use some natural antimicrobial agents (chitosan) to compose with, which is antimicrobial, wear resisting, high intensity, and anti-corrosion, to achieve the composition of two materials and meet the requirements of the space station.

## 25.5 Conclusion

In this paper, the process of anti-mildew test of non-metal materials is described. We analyze the reasons and mechanisms of microbial growth, mainly for those weak antifungal polymers, such as sealing rubber, decorative material, plastic, resin and textile fiber, and also propose the schemes used for antimicrobial treatment of materials.

In addition, from the analysis of physiological and biochemical characteristics of microorganisms found in ISS, we have learned that the corrosion ability and environmental adaptability of the microbes have generally increased. Therefore, we should set higher requirements for the anti-mildew ability to the materials in the space station and propose more effective anti-mildew methods for the materials.

## References

1. Novikova N, De Boever P, Poddubko S, Deshevaya E et al (2006) Survey of environmental biocontamination on board the International Space Station. *Res Microbiolo* 157:5–12
2. Novikova ND (2004) Review of the knowledge of microbial contamination of the Russian manned spacecraft. *Microbiolo Ecol* 47(2):127–132
3. Novikova ND (2012) Microbiological contamination and control in the manned spacecraft, state scientific center of the russian federation—Institute for Biomedical Problems of the Russian Academy of Sciences, Moscow, Russia
4. GJB150.10A-2009. Laboratory environmental test methods for military material—Part 10:Fungus test
5. Shu X, Shi Q, Ouyang Y et al (2009) The research progress on microbiological deterioration of several polymers, *Plastic Industry* Volume 10 Chapter 37, 1005—5770, 10—0001—04
6. Xu S, Wei M, Zhao C et al 2005 Applications of inorganic anti-microbial polymer materials in manned spaceflight technology[C], First annual conference of China Aerospace Association
7. Xu X, Duan X, Zhou Z et al (2009) Feasibility study of the long effect anti-microbial materials in the space equipment, *Space environment and materials science*, 2009
8. Chen J, Ma X, (2008) Research progress and market condition of anti-microbial materials, In: 6th China anti-microbial development conference, 2008

# Chapter 26

## A Model Construction Based on Research Capability of Laboratory Environmental Worthiness

Zhibing Pang, Hualiang Xu, Zaochen Liu, Hongyan Ou, Chenhui Li and Cheng Jin

**Abstract** The essay develops model construction and introduces fuzzy comprehensive evaluation methods directing at the characteristics that there exist a lot of fuzzy and uncertain factors in the evaluation of laboratory environmental worthiness. The evaluation index system on research capability of laboratory environmental worthiness is set up, comprehensive evaluation model is constructed, methods and steps of comprehensive evaluation are introduced, and the feasibility and rationality of methods are verified through the practical cases. The essay has played an important guidance for developing equipment purchase of environmental worthiness research and doing quantitative experiments.

**Keywords** Laboratory · Environmental worthiness · Research capability · Model construction

### 26.1 Introduction

The US military standard MIL-STD-810F Environmental Engineering Consideration and Laboratory Experiment was issued in 2000. Firstly, it defined the concept of environmental worthiness. It is described that equipments, subsystem, or parts realize the full predesigned function under the prospective environment [1].

In China, general requirements for environmental engineering of equipments (GJB4239) have also given a clear definition on environmental worthiness. It is described that equipments (products) are estimated to realize their all predesigned function and performance and/or undamaged ability under the possible facing interaction of all the environments within their life expectancy and are one of the main qualities and characteristics [2]. The experts describe the environmental

---

Z. Pang (✉) · H. Xu · Z. Liu · H. Ou · C. Li · C. Jin  
Air Defense Forces Academy, Zhengzhou 450052, China  
e-mail: fkb\_mmes@163.com

worthiness at four levels, that is: environment, function, performance, and undamaged ability.

Researching environmental worthiness of equipment has an important significance for promoting technological performance of equipments operations and improving generation and progress of combat effectiveness. The laboratory is an important place for researching environmental worthiness; in laboratory, it is beneficial to summing up the experience, finding and overcoming the weak points, improving the research capability of environmental worthiness, and promoting the full development of laboratory to evaluate the research capability of environmental worthiness [3].

There exist a lot of fuzzy and uncertain factors in the evaluation of research capability of laboratory environmental worthiness. Firstly, research capability is a fuzzy concept; we cannot describe it in accurate mathematic methods. Secondly, the descriptions of evaluation index status are uncertain. Fuzzy comprehensive judgment is a kind of evaluation method that is based on fuzzy mathematics and quantifying some ambiguous and unclear factors in accordance with principles on synthesis of fuzzy relation. Comprehensive evaluation applying comprehensive fuzzy judgment for research capability of laboratory environmental worthiness may improve objectivity and impartiality of evaluation result.

## 26.2 Comprehensive Evaluation Models of Research Capability

### 26.2.1 The Factor Sets

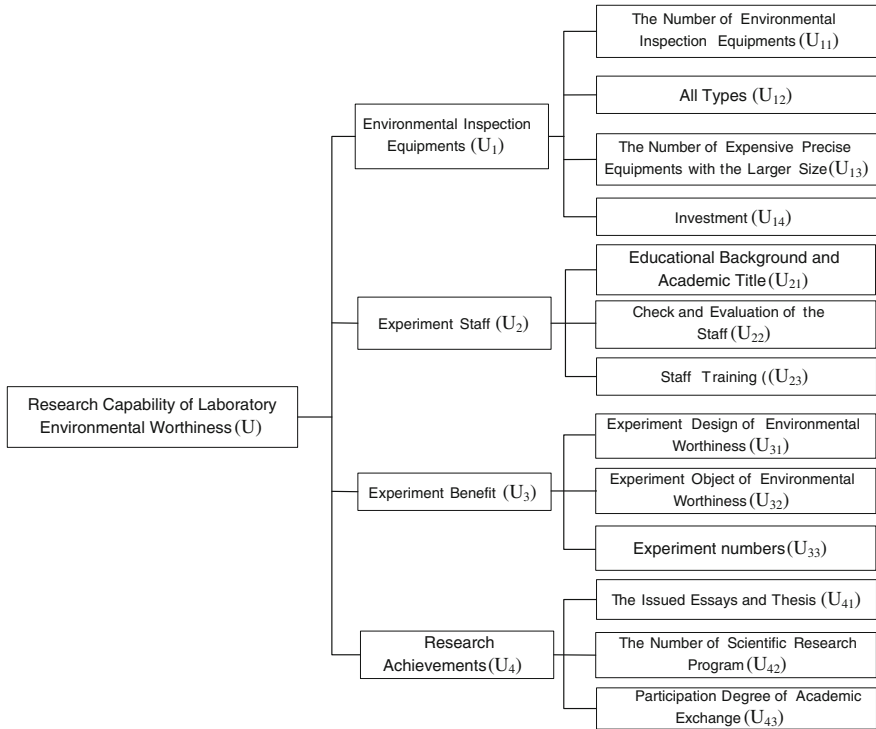
On the basis of consulting a lot of information and extensively asking for the experts' advice, the evaluation index system of research capability of laboratory environmental worthiness is confirmed (Fig. 26.1). The system includes three levels: target level, the criterion level, and the subcriterion level; they are classified first-level index, second-level index, and third-level index, respectively. The factor set of first-level index is  $\{U\}$ , the factor set of second-level index is  $\{U_1, U_2, U_3, U_4\}$ , and the factor set of third-level index is:

$$\{U_{11}, U_{12}, U_{13}, U_{14}; U_{21}, U_{22}, U_{23}; U_{31}, U_{32}, U_{33}; U_{41}, U_{42}, U_{43}\}.$$

### 26.2.2 The Weight Sets

In the comprehensive evaluation, the weight sets are crucial. It reflects the position that each factor has dominated or the role that each factor has played during the comprehensive evaluation and directly influences the result of comprehensive





**Fig. 26.1** Evaluation index system of research capability of laboratory environmental worthiness

evaluation. In general, each index in one level has different importance. Important indexes must be issued more weights. In the present evaluation methods, there are two classifications for the confirmation methods of weights: One is subjective weighting approach, in other words, index weight is determined by experts according to experience and subjective judgment, e.g., analytical hierarchy process (AHP) and the least square method. Another is objective weighting approach; weight is confirmed according to the relations among original data, e.g., the entropy method and correlation method [4]. As for index system from Fig. 26.1, the weight set is described as follows:

Second-level index weight:  $A = \{a_1, a_2, a_3, a_4\}$

Third-level index weight:  $A_i = \{a_{i1}, a_{i2}, \dots, a_{ik}\}$

$a_{ik}$  is the weight of the number  $j$  factor of the third-level index under the number  $i$  factor of the second-level index. Obviously, if  $i = 1, 2, 3, 4$ , then  $j = 1, 2, \dots, 4$ , and  $\sum_{k=1}^j a_{ik} = 1$ .

**Table 26.1** Quantitative standard of evaluation

Evaluation value	$0.75 < H \leq 1.00$	$0.50 < H \leq 0.75$	$0.25 < H \leq 0.50$	$0.00 < H \leq 0.25$
Remark	Excellent	Good	Fair	Poor

### 26.2.3 The Remark Sets

The remark sets are concluded by the experts according to practical need. Normally, the remark sets are composed of four levels; they are excellent, good, fair, and poor in 4-level semantic scale:  $H = \{h_1, h_2, h_3, h_4\}$ . In combination with the experts' advice, quantitative standards of evaluation are as follows (Table 26.1).

## 26.3 Steps of Fuzzy Comprehensive Evaluation of Research Capability

### 26.3.1 Confirmation of Fuzzy Evaluation Sets

The evaluation panel being composed of  $n$  leaders, and experts assesses the third-level index and confirms the fuzzy evaluation sets by means of fuzzy statistic methods. The judging methods are flexible, different test methods may be adopted to acquire reliable data, and relatively scientifically, comprehensively and accurately evaluate every index, e.g., the interview, questionnaire survey, the practical operation method, etc., suppose the evaluation panel considers the number of the people with the remark excellent, good, fair, and poor under the certain factor of third-level index as  $P_1, P_2, P_3, P_4$ , respectively, then fuzzy evaluation sets that confirm the factor are:

$$R_{ij} = \left\{ \frac{p_1}{n}, \frac{p_2}{n}, \frac{p_3}{n}, \frac{p_4}{n} \right\} = \{r_{ij1}, r_{ij2}, r_{ij3}, r_{ij4}\} \tag{26.1}$$

Then, fuzzy evaluation sets of the second-level index are [5]:

$$R_i = \begin{bmatrix} r_{i11} & r_{i12} & r_{i13} & r_{i14} \\ r_{i21} & r_{i22} & r_{i23} & r_{i24} \\ \dots & \dots & \dots & \dots \\ r_{ij1} & r_{ij2} & r_{ij3} & r_{ij4} \end{bmatrix} \tag{26.2}$$

In formula (26.2), the definition of  $i$  and  $j$  is the same as 2.2.

### 26.3.2 First-Level Fuzzy Evaluation

First-level evaluation is the exact assessment toward each factor of third-level index that considers the assessment result (formula 26.2) as fuzzy matrix of corresponding second-level index factors and multiply the weight of each factor of the third-level index in accordance with matrix mode. Then, obtain membership matrix whose assessment result belongs to  $h_1, h_2, h_3$ , and  $h_4$ . Membership matrix of first-level evaluation result is:

$$B_i = \{b_{i1}, b_{i2}, b_{i3}, b_{i4}\} = A_i \cdot R_i \quad (26.3)$$

In formula (26.3),  $b_{i1}, b_{i2}, b_{i3}$ , and  $b_{i4}$ , respectively, show membership ( $i = 1, 2, 3, 4$ ) of third-level index  $i$  whose assessment result belongs to of  $h_1, h_2, h_3$  and  $h_4$ .

### 26.3.3 Second-Level Fuzzy Evaluation

We make the first-level evaluation result (formula 26.3) by multiplying the weight of each factor of second-level index according to matrix mode and then obtain membership matrix whose evaluation result belongs to  $h_1, h_2, h_3$  and  $h_4$ . Membership matrix of second-level evaluation result is:

$$B = \{b_1, b_2, b_3, b_4\} = A \cdot B_i \quad (26.4)$$

In formula (26.4),  $b_1, b_2, b_3$ , and  $b_4$ , respectively, show the membership in which research capability of laboratory environmental worthiness belongs to  $h_1, h_2, h_3$ , and  $h_4$ .

### 26.3.4 Comprehensive Fuzzy Evaluations

We make the second-level evaluation result (formula 26.3) by multiplying evaluation set vector and obtain the final quantitative evaluation result on research capability of laboratory environmental worthiness. The formula is:

$$Z = B \cdot H \quad (26.5)$$

**Table 26.2** Judgment result

Evaluation index	Vote for each evaluation hierarchy			
	Excellent	Good	Fair	Poor
$U_{11}$	1	5	4	0
$U_{12}$	2	6	2	0
$U_{13}$	0	6	3	1
$U_{14}$	1	4	5	0
$U_{21}$	3	5	2	0
$U_{22}$	4	3	3	0
$U_{23}$	5	4	1	0
$U_{31}$	8	2	0	0
$U_{33}$	6	4	0	0
$U_{32}$	4	5	1	0
$U_{41}$	7	2	1	0
$U_{42}$	2	7	1	0
$U_{43}$	9	0	1	0

### 26.4 Application Cases

To evaluate the research capability of environmental worthiness at certain laboratory, the index weight is confirmed [6]:

$$\begin{aligned}
 A &= \{0.3, 0.3, 0.15, 0.25\}, & A_1 &= \{0.2, 0.3, 0.3, 0.2\}, \\
 A_2 &= \{0.4, 0.4, 0.2\}, & A_3 &= \{0.4, 0.4, 0.2\}, \\
 A_4 &= \{0.3, 0.4, 0.3\}
 \end{aligned}$$

The evaluation panel being composed of 10 experts, respectively, assess third-level index on research capability of laboratory environmental worthiness, the votes that each index obtains are as follows (Table 26.2).

After calculation, second-level fuzzy evaluation result is :  $B = \{0.38, 0.418, 0.193, 0.009\}$ , fuzzy comprehensive evaluation result is:  $Z = 0.7923$ . The research capability of laboratory environmental worthiness is evaluated as excellent in contrast to quantitative evaluation standard.

### 26.5 Conclusions

Cultivating consciousness and quality of man-machine-environment system engineering and realizing that it plays active role in developing arms and equipments and experiments will have an important significance for improving

environmental worthiness of equipments [7]. The practical cases have shown that making use of fuzzy comprehensive evaluation method is simple and easy to judge the research capability of laboratory environmental worthiness and can overcome the error that some uncertain factors bring during the process of evaluation and achieve relatively objective, scientific, correct, and comprehensive evaluation result. It can not only comprehensively evaluate the research capability of laboratory environmental worthiness, but also quantitatively reflect the exact situation of each subordinate factor; it provides the principal evidence for the laboratory to find the difference and make up for difference and then make the final decision. It may forcefully make rapid progress for research capability of environmental worthiness and push the full construction of laboratory.

## References

1. MIL-STD-810F military standard Environmental Engineering Consideration and Laboratory Experiment (2000)
2. GJB 4239—2001, General requirements for environmental engineering of equipments
3. Tang C (2012) Research on environmental worthiness of HQ-7B Launching control vehicle in the Southeastern Coast. Air Defense Forces Command Academy, pp 14–16
4. Xin H (2010) Application of comprehensive fuzzy evaluation in the judgment of ability. *J Sichuan Arms* 7
5. Xie J, Liu C (1999) Fuzzy mathematic methods and its application. Science Press, Wuhan
6. Wen C (2006) Evaluation index of teaching laboratory and comprehensive judgment. *High Archit Educ* 12
7. Pang Z (1999) Air defense forces man-machine-environment system engineering. Air Defense Forces Academy, Zhengzhou, pp 136–141

**Part IV**  
**Research on the Man–Machine**  
**Relationship**

# Chapter 27

## Study on Impact Analysis of Eye Movement Data to the Bottom-Up Significant Area Calculation Model

Yajuan Bai, Meng Yang, Yaofeng He, Yuping Luo  
and Guansheng Huang

**Abstract** In view of the eye movement data to improve the bottom-up area calculation model, the modified artificial calculation model for calculation of psychological experiments before and after pictures of a significant area, psychology experiment and computer model calculation results by comparison and analysis of the eye movement data of significant influence and the reasons of the area calculation model, for the eye movement data significantly improved computer area calculation model and provides the interpretation of the psychology. The results showed that the eye movement data improved significantly the area calculation model more in line with the human visual system characteristics. Significant area calculation model of recognition effect is improved obviously.

**Keywords** Eye movement · Bottom-up · Significant area · Selective attention

### 27.1 Introduction

Visual significant recognizing area can be used for object exploring, predicting human eye fixation points, video compression, picture quality assessment, etc. In the recent years, it has become the hot issue of research. Generally, picture significance area can be concerned more, which embodies the selective attention of human visual system. The calculation model of computer significant area adopts mathematics model to imitate the visual characteristics. It is divided into two aspects: bottom-up model driven by feature and top-bottom model driven by task.

---

Y. Bai (✉) · Y. He · Y. Luo · G. Huang  
Beijing Special Vehicle Institute, Beijing 100072, China  
e-mail: zhjbjs@163.com

M. Yang  
Beijing Normal University, Beijing 100072, China

Top-bottom model driven by task depends on the specific task. It is very difficult to establish generalized top-down calculating model of significant area. Thus, it develops very slowly. Bottom-up model driven by feature, due to its only application to bottom-level feature, is beneficial to establish generalized calculating model of significant area. Iitt's feature integrated model [1] utilizes the local physical features of photographs (colour, orientation and luminance), simulates human eyes' horizon's centre, periphery features, forms the significant figure of all physical features, then makes linear integration on all significant figure and adopts the competitive strategies of the winner, taking it all to determine the final significant area and watching sequence. Although Iitt's feature integrated model can realize good recognizing effect under some conditions, due to its only utilizing local features and low-level physical features, the data consistency of eye movement of the model and when people watch photographs is not very good. On this basis, many people propose many different significant analyzing methods, as shown in Figure GBVS [2].

The frequency spectrum residual calculation model [3] appeared by utilizing the overall feature of photographs. Due to the increase in the application of overall physical features of photographs, the recognizing overall integrated model on the significance area is improved. However, due to its establishment on low-level physical features basis, the recognizing ratio of complex photographs at significance area is not significantly improved.

The eye movement data of people's watching photographs, directly reflecting people's recognition on the significant area of photographs. Adopting eye movement data to improve the calculating model based on frequency spectrum residual error and making calculating model learn the human's visual feature through training are the effective methods to improve the calculating model.

The improvement effect on calculating model by using eye movement data is verified by true photographs in the past. However, the calculating results of significance area of the true photographs are the comprehensive effect of variant factors. It is difficult to differentiate the influence of model on single physical feature; thus, it is unbeneficial to the objective comment on the improved effect of calculated model.

Thus, this paper proposes the manual photograph of psychological test to verify on the improved effect of eye movement data to the calculated model, adopts the three factors' selective attention psychological test results to contract with the calculating model before and after improvement, and analyses the improved features and reasons of calculating models of eye movement data. It provides the psychological explanation and subsequent research direction for the improved bottom-top calculating model of adopting eye movement data.



## 27.2 Psychological Verification Test of Selective Attention

In the psychological field, selective attention has the following three features. The first kind is stimulus-driven capture view [4]; this view holds that when people focus on feedforward visual working, the attention on stimulus mainly depends on feature significance, and the significance of bottom-down feature determines the sequence of selective attention. The second kind is the conditional contingent capture hypothesis [5]; this view holds that only when unique feature factor has the feature related to tasks can be paid attention to. The choice to stimulus is always affected by implicitly hiding or explicitly clear task objectives, that is, top-down affect. The third kind is dimension-weighting account [6]; this view holds that people's attention to unique feature factor is affected by top-down model and down-top model.

This research selects an experimental pattern supporting bottom-top opinions—extra singleton searching model [7] (Additional singleton search task). The stimulus materials in test include colour significance, shape significance and semantic significance. The classic test of singleton is added with meaningful photographs and meaningless photographs to explore the semantic significance. The testing results show that, when stimulating materials are meaningless objects, the results support the bottom-down opinions; then, the stimulus materials are meaningful objects, and it supports the results.

The top-down opinion is that whether the feature (shape) related to tasks can beat the more significant feature (colour) in physical stimulus is adjusted by meaningful stimulus or not; this condition is affected by the fact whether features are matchable.

## 27.3 Contrast and Analysis of Calculating Results Between Psychological Test and Computer Model

### 27.3.1 *Contrast of Calculating Results Between Psychological Test and Computer Model*

#### (1) Meaningless photographs (Fig. 27.1)

The recognition of the significance of difference in original model is incorrect. The improved model embodies good shape-recognizing capacity, shape difference sensibility, and comprehensive identifying ability. The identified results of computer after improvement are basically consistency of psychological experimental results.

Original model cannot distinguish colour difference. The significance recognition of shape difference is incorrect. The improved model embodies the good simple shape-identifying ability, simple shape difference-sensitive colour difference sensibility, and comprehensive identifying ability. The identified results of

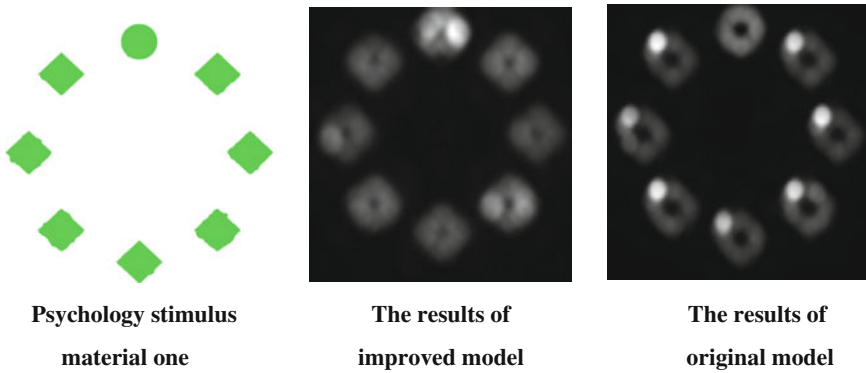


Fig. 27.1 Contrast figure of experiment one

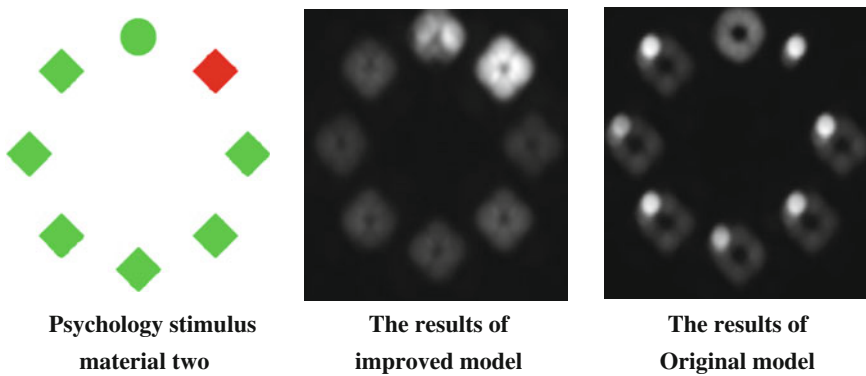


Fig. 27.2 Contrast figure of experiment two

computer after improvement are basically consistency of psychological experimental results (Fig. 27.2).

## (2) Meaningful photographs (Fig. 27.3)

The identification feature is satisfactory of the original model complex figures. The identification of shape difference significance is correct. The improved models do not embody the significant improvement of complex shape-identifying ability, low difference sensibility of complex shapes and unclear comprehensive identifying capacity. The identified results of computer before and after improvement are basically inconsistency of psychological experimental results (Fig. 27.4).

Pay attention to the sequence before psychological testing results, green flowers, red leaves and green flowers. It embodies the influence on front attention sequence of semantic features. The original model embodies the significance of shape difference and does not indicate the significance of colour difference and semantic features. The improved model embodies the significance of colour

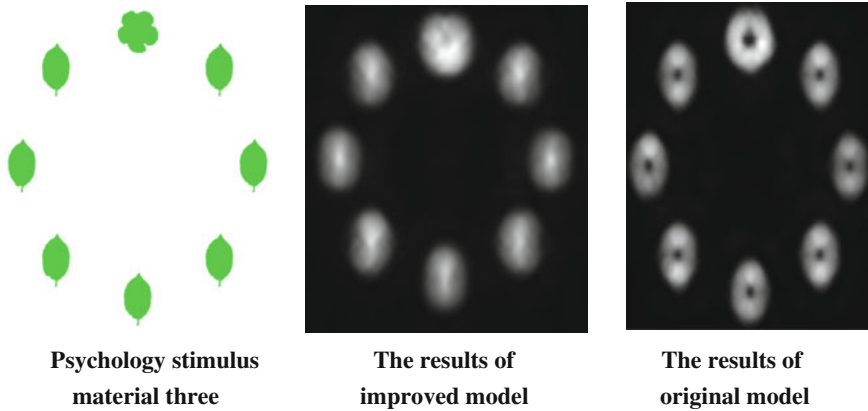


Fig. 27.3 Contrast figure of experiment three

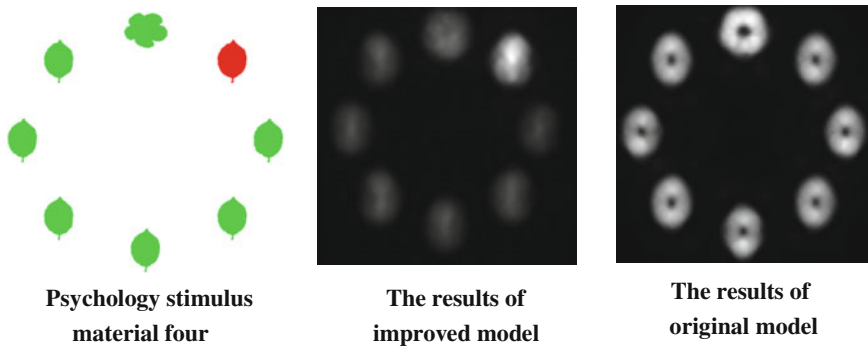


Fig. 27.4 Contrast figure of experiment four

difference, but does not indicate shape difference significance and the influence of semantic features on significance. The identified results of computer before and after improvement are basically inconsistency of psychological experimental results (Fig. 27.5).

Pay attention to the sequence before psychological testing results, green leaves and green flowers. The significance identification of shape difference of original model is incorrect. The original model has low sensitivity to shape difference. The improved model embodies the significance of shape difference and has lower shape sensitivity. The identified results of computer after improvement are basically consistency of psychological experimental results (Fig. 27.6).

Pay attention to the sequence before psychological testing results, red flowers, green leaves and green flowers. The significance identification of shape difference of original model is incorrect. And the significance identification of shape difference is incorrect. The improved model embodies the significance of colour

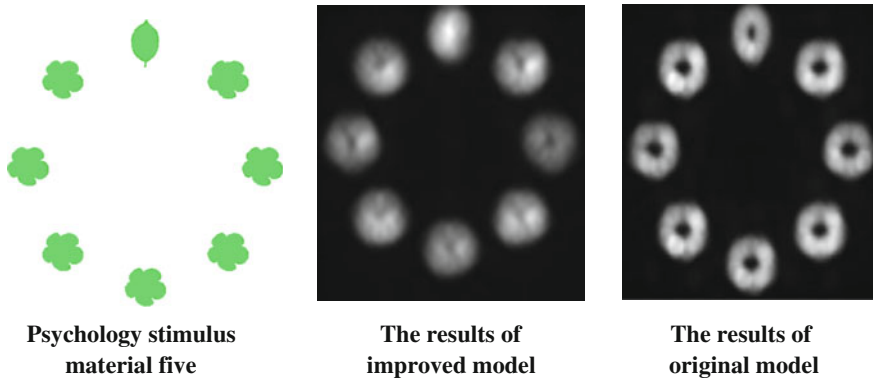


Fig. 27.5 Contrast figure of experiment five

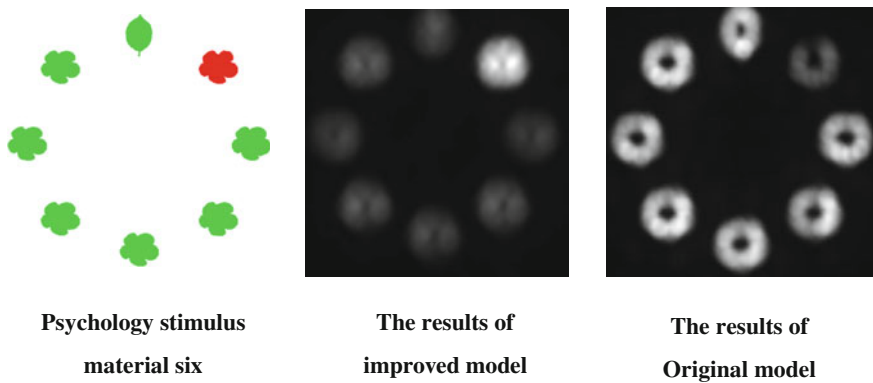


Fig. 27.6 Contrast figure of experiment six

difference and does not indicate shape difference significance. The identified results of computer after improvement are basically consistency of psychological experimental results.

### 27.3.2 Feature and Reasons Analysis of the Improved Models

- (1) Improved mode embodies the colour difference, shape difference and comprehensive difference identifying capacity better than the original models.

Analysis of reasons: seen from using the method of eye movement data, it amounts to focussing the significance area scope according to the eye movement data, eliminating the large unreeled significant area apart from calculation and intensifying the significance and identification of local shape.

Human eyes' perceptual ability to colour difference reflects in the eye movement data. Thus, after training, the colour difference-perceiving ability of the improved model is improved slightly.

Human eye movement data result from the perception signification comprehensive identification of shape, colour, orientation and luminance. Thus, after adopting eye movement data training, the improved data indicate the improvement of comprehensive identifying ability.

- (2) The improved model illustrates high sensitivity to colour difference, low sensitivity to shape difference and no identifying capacity to semantic significance.

Possible reasons: Due to the roughly same meaningful area as the meaningless area in eye movement training samples, the meaningless area quantity is slightly improved and does not have conscious semantic significance training on calculating model. Thus, models cannot embody the improvement of semantic significance capacity.

## 27.4 Discussion and Conclusion

- (1) Adopting eye movement data can improve the bottom-top visual significance area calculating model to some extent.
- (2) Adopting classic psychological experimental artificial photographs and experimental results can effectively verify the improved effect of calculating models of visual significance area.
- (3) Adopting eye movement data to improve the calculating model of bottom-down visual significance are. The selection of eye movement data sample is very important.

## References

1. Nurmi D, Wolski R, Grzegorzczyk C et al (2008) Eucalyptus: a technical report on an elastic utility computing architecture linking your programs to useful systems. UCSB Computer Science, California
2. Siebenlist F (2009) Challenges and opportunities for virtualized security in the clouds. In: Proceedings of the 14th ACM symposium on access control models and technologies, SACMAT. 09. ACM, New York, USA, pp 1–2
3. Clark C, Fraser K, Hand S et al (2005) Live migration of virtual machines. In: Proceedings of NSDI. 05. Berkeley, CA, USA, pp 273–286
4. Theeuwes J (1991) Cross-dimensional perceptual selectivity. *Percept Psychophys* 50(2):184–193
5. Folk CL, Remington RW, Johnston JC (1992) Involuntary covert orienting is contingent on attentional control settings. *J Exp Psychol Hum Percept Perform* 18(4):1030–1044

6. Müller HJ, Heller D, Ziegler J (1995) Visual search for singleton feature targets within and across feature dimensions. *Percept Psychophys* 57(1):1–17
7. Kawahara J-I (2010) Identifying a “default” visual search mode with operant conditioning. *Acta Psychol* 135:38–49

# Chapter 28

## Integrated Evaluation of Pilot Situational Awareness in Man–Machine Interaction

Binchun Liu and Wanqing Li

**Abstract** Scientific and reasonable evaluation of pilot situational awareness play an important role in pilot scenario cognitive skills training quantification, targeted to develop training programs and improving the flight technical level, and ensuring flight safety. At present, national rating situational awareness is mainly based on a comprehensive evaluation of operating efficiency measurements, this method is objective, non-interference and easy to use, the problem is it may not truly reflect situational awareness levels of the operator. This paper evaluates pilot situational awareness by using method integrated by frozen measurement techniques which best meet the Endsley definition of situational awareness, gray clustering synthetic evaluation, and fuzzy synthetic evaluation.

**Keywords** Pilot · Situation awareness · Gray clustering synthetic evaluation · Fuzzy synthetic evaluation

### 28.1 Introduction

The most widely introduced definition by situation awareness (SA) is proposed by Endsley [1]. He thought that SA perceives, understands the component parts within the environment of certain time and space, and predicts the following changing conditions of these parts. The difference between the research orientation of SA and research field would cause different SA measuring methods and difference of the evaluation methods. Currently, the most representative measurement and evaluation on China domestic aviators' SA mainly adopt the fuzzy synthetic evaluation method of working performance measurement [2]. This method utilizes

---

B. Liu (✉) · W. Li  
Aviation Theory Department, Air Force Aviation University, Changchun 130022, Jilin, China  
e-mail: huangtsg@126.com

the task to express the assessment operators' SA level, with the advantages of objectives, no interference, and easy for use. The research shows that high SA may be the necessary conditions with good performance, but not the sufficient conditions.

Therefore, the maximum issue of working performance measurement may not really represent the SA level of the operators.

SA of the flying cadets, in this research, adopts freezing measurement technology, gray clustering comprehensive judgment, and fuzzy synthetic evaluation method for assessment. Freezing measurement technology belongs to the memory exploring technological category. This measurement method fits Endsley's definition on SA.

This paper deals with the data collection, analysis, and evaluation of traffic pattern on the tested flying cadets (flying about 15 h) on the preliminary training flight simulator. The action sequence and collecting points of traffic pattern refer to Fig. 28.1.

## **28.2 Situation Awareness Comprehensive Judgment Hierarchical Division of Flying Cadets Based on "Three-Hierarchical Model"**

### ***28.2.1 Situation Awareness Comprehensive Judgment Hierarchical Division of Flying Cadets***

"Three-Hierarchical Model" theory [3] means that SA can be divided into three phases: the first phase, perception to the current context components; the second phase, comprehensive situation understanding; the third phase, prediction and planning for the following situation.

Based on the above-mentioned theory, according to the simulated flight of traffic pattern of flying cadets, establish the comprehensive judgment hierarchical figure of SA, referring to Fig. 28.2.

### ***28.2.2 Experimental Method***

This experiment uses freezing measurement technology and proposes questions to the testees at the interval of simulated flight. Simulation task stops at several key timing points. All the information related to the tasks is eliminated. During the freezing period, the testees answer the issues related to the SA. The mastering principles of testing include, firstly, the reasonable structure of the measured point indicator system; secondly, the time control of the testees answering questions.



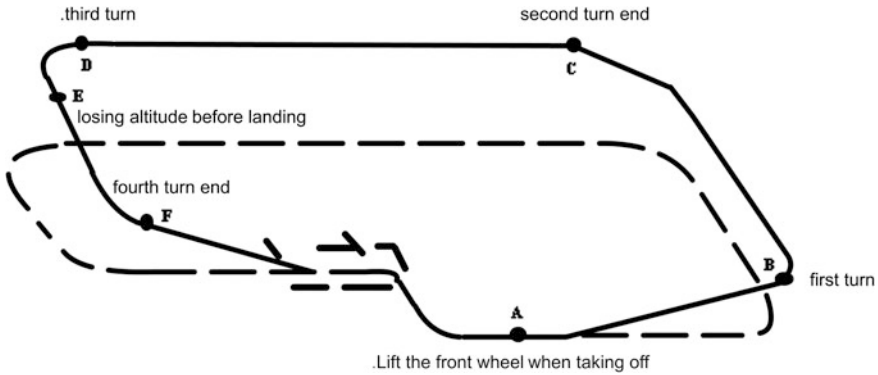


Fig. 28.1 Action sequence of takeoff and landing flights

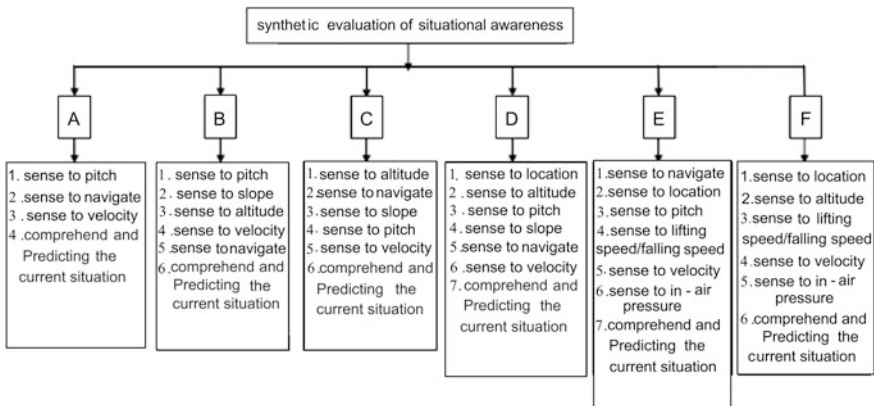


Fig. 28.2 Two-degree synthetic evaluation hierarchy chart of situational awareness

## 28.3 Comprehensive Judgment Hierarchy of Situation Awareness

### 28.3.1 Judgment Model of Hierarchies of Situation Awareness

In view that the flying cadets take subjective assessment as the primary objects and some limitation and fuzziness exist in their cognition, the first-level comprehensive assessment selects and uses clustered comprehensive evaluation method and the second-level comprehensive evaluation selects fuzzy comprehensive evaluation method.

### 28.3.1.1 The Mathematical Model of White Functions in Gray Clustering Analysis

Considering that the single value and multivaluedness of classic white function, upper limit measurement white function and lower limit measurement white function meet the humans' thought features and non-uniqueness of subjective assessment solution, select them as the gray analysis function of SA [4].

Classic white functions are recorded as  $f_j^k [x_j^k(1), x_j^k(2), x_j^k(3), x_j^k(4)]$ ; upper limit measurement white functions are recorded as  $f_j^k [x_j^k(1), x_j^k(2), -, -]$ ; and the lower limit measurement white functions are recorded as  $f_j^k [-, -, x_j^k(3), x_j^k(4)]$ . Among them,  $x_j^k(1), x_j^k(2), x_j^k(3)$  and  $x_j^k(4)$  are the turning points of  $f_j^k(\cdot)$ .

Adopt five categories of {Excellent, Fairly good, Medium level, Poor level, and Very poor level} as the information overlaying of subjective assessment of indicators on flying cadets' SA [5]. Take the turning points of white function of each category as follows:

- Excellent:  $f^1[87, 93, -, -]$
- Fairly good:  $f^2[77, 83, 87, 93]$
- Medium level:  $f^3[67, 73, 77, 83]$
- Poor level:  $f^4[57, 63, 67, 73]$
- Very poor level:  $f^5[-, -, 57, 63]$

Substitute the turning points of all categories into the corresponding upper limit measurement white functions, typical white functions and the lower limit measurement white functions. Then, the mathematical models of white functions of all categories can be obtained.

$$f^1(x) = \begin{cases} 0 & x < 87 \\ \frac{x-87}{6} & x \in [87, 93] \\ 1 & x \geq 93 \end{cases} \quad (28.1)$$

$$f^2(x) = \begin{cases} 0 & x \notin [77, 93] \\ \frac{x-77}{6} & x \in [77, 83] \\ 1 & x \in [83, 87] \\ \frac{93-x}{6} & x \in [87, 93] \end{cases} \quad (28.2)$$

$$f^3(x) = \begin{cases} 0 & x \notin [67, 83] \\ \frac{x-67}{6} & x \in [67, 73] \\ 1 & x \in [73, 77] \\ \frac{83-x}{6} & x \in [77, 83] \end{cases} \quad (28.3)$$

$$f^4(x) = \begin{cases} 0 & x \notin [57, 73] \\ \frac{x-57}{6} & x \in [57, 63] \\ 1 & x \in [63, 67] \\ \frac{73-x}{6} & x \in [67, 73] \end{cases} \tag{28.4}$$

$$f^5(x) = \begin{cases} 0 & x \notin [0, 63] \\ 1 & x \in [0, 57] \\ \frac{63-x}{6} & x \in [57, 63] \end{cases} \tag{28.5}$$

**28.3.1.2 Fuzzy Synthetic Evaluation Model**

Fuzzy synthetic evaluation scale selects evaluation set  $V$  and the affecting factors set  $U$  of evaluation objects

$$V = \{v_1, v_2, \dots, v_m\}$$

$$U = \{u_1, u_2, \dots, u_n\}$$

In the above formula,  $m$  is the evaluation scale number;  $n$  is the number of affecting factors.

All affecting factors have different importance degree to the evaluated matters of property. Fuzzy subset  $A$  may be used to express.

$$A = (a_1, a_1, \dots, a_n)$$

In the formula,  $a_i$  is the degree of membership of  $u_i$  to  $A$ . As weight coefficient,  $\sum_{i=1}^m a_i = 1$ .

Thus, conduct synthetic judgment through fuzzy change.

$$P = A \circ R = (p_1, p_2, \dots, p_m) \tag{28.6}$$

All factors  $p_j$  in  $P$  is the operation results derived from the generalized fuzzy compositional operation. Considering the weight average type  $M(\cdot, \oplus)$ , not only considering all the affecting factors, but also reserving the judgment information of single factor, the second-level judgment of this research adopts this mode.

**28.3.2 The Confirmation of Flying Cadets Situation Awareness on Hierarchy Weight Coefficient**

The first layer clusters clustering weight coefficient, and the second layer of importance degree shall be obtained by analytic hierarchy process (AHP) [6]. Aiming at some flying cadet A, measure his weight values of indicator clusters groups referring to Tables 28.1, 28.2, 28.3, 28.4, 28.5 and 28.6.

**Table 28.1** Evaluation index  $\eta_j$  and evaluation value in A point

Evaluation index	The clustering weights $\eta_j$	Evaluation value
1. Sense to pitch	0.28	95
2. Sense to navigate	0.25	90
3. Sense to velocity	0.16	87
4. Comprehend and predicting the current situation	0.31	88

**Table 28.2** Evaluation index  $\eta_j$  and evaluation value in B point

Evaluation index	The clustering weights $\eta_j$	Evaluation value
1. Sense to pitch	0.20	90
2. Sense to slope	0.18	90
3. Sense to altitude	0.13	92
4. Sense to velocity	0.13	80
5. Sense to navigate	0.06	85
6. Comprehend and predicting the current situation	0.30	86

**Table 28.3** Evaluation index  $\eta_j$  and evaluation value in C point

Evaluation index	The clustering weights $\eta_j$	Evaluation value
1. Sense to pitch	0.13	85
2. Sense to slope	0.14	90
3. Sense to altitude	0.18	90
4. Sense to velocity	0.08	80
5. Sense to navigate	0.17	88
6. Comprehend and predicting the current situation	0.30	86

In the same way, experts can obtain the level two synthetic judgment weight value as follows based on the task difficulties of six key points.

$$A' = (0.1, 0.13, 0.16, 0.16, 0.2, 0.25)$$

**Table 28.4** Evaluation index  $\eta_j$  and evaluation value in D point

Evaluation index	The clustering weights $\eta_j$	Evaluation value
1. Sense to pitch	0.11	86
2. Sense to slope	0.10	86
3. Sense to altitude	0.16	90
4. Sense to velocity	0.07	70
5. Sense to navigate	0.09	73
6. Sense to location	0.17	92
7. Comprehend and predicting the current situation	0.30	83

**Table 28.5** Evaluation index  $\eta_j$  and evaluation value in E point

Evaluation index	The clustering weights $\eta_j$	Evaluation value
1. Sense to pitch	0.11	85
2. Sense to lifting speed/ falling speed	0.11	80
3. Sense to in-air pressure	0.08	70
4. Sense to velocity	0.08	70
5. Sense to navigate	0.17	92
6. Sense to location	0.15	90
7. Comprehend and predicting the current situation	0.30	82

**Table 28.6** Evaluation index  $\eta_j$  and evaluation value in F point

Evaluation index	The clustering weights $\eta_j$	Evaluation value
1. Sense to lifting speed/ falling speed	0.16	75
2. Sense to in-air pressure	0.09	63
3. Sense to velocity	0.11	80
4. Sense to altitude	0.16	90
5. Sense to location	0.18	92
6. Comprehend and predicting the current situation	0.30	83

### 28.3.3 Variant Synthetic Judgment of Situation Awareness of Flying Cadet

#### 28.3.3.1 Grade One Synthetic Judgment

According to the synthetic evaluating standard of all indicators, obtain the average synthetic evaluating score of all indicators (Tables 28.1, 28.2, 28.3, 28.4, 28.5, and 28.6) aiming at some flying cadet A. Substitute the formula  $\sigma_i^k = \sum_{j=1}^m f_j^k(x_{ij}) \cdot \eta_j$  with formula (28.1)–(28.5) and data in Tables 28.1, 28.2, 28.3, 28.4, 28.5, and 28.6. Then, the gray clustering at six key points can be obtained for some flying cadet A.

$$\begin{aligned} \sigma_A^k &= (\sigma_A^1, \sigma_A^2, \dots, \sigma_A^5) = (0.456, 0.543, 0, 0, 0) \\ \sigma_B^k &= (\sigma_B^1, \sigma_B^2, \dots, \sigma_B^5) = (0.298, 0.636, 0.065, 0, 0) \\ \sigma_C^k &= (\sigma_C^1, \sigma_C^2, \dots, \sigma_C^5) = (0.188, 0.771, 0.051, 0, 0) \\ \sigma_D^k &= (\sigma_D^1, \sigma_D^2, \dots, \sigma_D^5) = (0.221, 0.618, 0.125, 0.035, 0) \\ \sigma_E^k &= (\sigma_E^1, \sigma_E^2, \dots, \sigma_E^5) = (0.216, 0.518, 0.185, 0.08, 0) \\ \sigma_F^k &= (\sigma_F^1, \sigma_F^2, \dots, \sigma_F^5) = (0.23, 0.465, 0.215, 0.09, 0) \end{aligned}$$

#### 28.3.3.2 Level 2 Comprehensive Judgment

Take the key points of A, B, C, D, E, and F as the six single factors. According to level two synthetic judgment weight value  $A'$  and formula (28.6) make the second-level judgment on some flying cadet A

$$\begin{aligned} P &= A' \circ R \\ &= (0.1, 0.13, 0.16, 0.16, 0.2, 0.25) \begin{bmatrix} 0.456 & 0.543 & 0 & 0 & 0 \\ 0.298 & 0.636 & 0.065 & 0 & 0 \\ 0.188 & 0.771 & 0.051 & 0 & 0 \\ 0.221 & 0.618 & 0.125 & 0.035 & 0 \\ 0.216 & 0.518 & 0.185 & 0.08 & 0 \\ 0.231 & 0.465 & 0.215 & 0.090 & 0 \end{bmatrix} \\ &= (0.254, 0.578, 0.460, 0.044, 0) \end{aligned}$$

Note: The flying cadet belongs to Excellent level by 0.254 membership degree, Fairly good level by 0.578 membership degree, Medium level by 0.460 membership degree, and low level by 0.044 membership degree.

## 28.4 Conclusion

1. In view that SA of flying cadet is dominated by subjective assessment and has limitation and vagueness to the recognition, the first-level synthetic judgment is suitable for adopting the gray clustering analysis method for subjective assessment; in order to keep applying the first-level information better, the second-level judgment adopts fuzzy synthetic assessment analysis method, applicable to the overall assessment of the SA of flying cadet. It is practicable and feasible.
2. Compare the assessment of SA of flying cadet and the assessment based on working performance SA. It is feasible to measure the flying cadets' attention distributing status, memory level, professional knowledge level, action response, correctness of action coordination, so as to formulate the training plan with pertinent purpose.

## References

1. Endsley MR (1995) Toward a theory of situation awareness in dynamic systems. *Hum Factors* 37(1):32–64
2. Liu W, Yuan X (2008) Design and evaluation of man–machine interaction. China Science and Technology Press, Beijing
3. Liu W, Yuan X et al (2004) Research on pilot situational sense. *J Haidian Univ Civil Aviation* 66(6):80–85
4. Liu S, Dang Y, Fang Z et al (2010) Grey theory and its applications. China Science and Technology Press, Beijing
5. Li T (2012) Analysis on consciousness influence factors in flight cockpit emergency. *China Sci Technol Inf* 09–13
6. Yang L, Gao Y (2001) The principle and application of fuzzy mathematics. South China Science and Technology Press, Guangzhou

# Chapter 29

## On the Eye Movement Technique-Based HMI Work Efficiency Evaluation System

Chenhui Li, Zhibing Pang, Zengjun Ji, Honglei Li, Haitao Zhao and He Wei

**Abstract** HMI is the interaction window between the equipment and the operator. It realizes the transformation of the equipment information from the internal to that can be accepted by the operator. It is a very important component in the overall design of equipment, which may affect the operation and combat efficiency. The paper aims to evaluate and optimize the HMI of equipment. First, the authors elaborate the basic functions of the experimental system for HMI evaluation; then, they analyze the hardware and software composition of the system; finally, they foresee the application of the system in industrial design, basic instruction, and operation training. At the same time, the paper may guide the design and construction of the experimental platform for the general-purpose HMI evaluation and optimization.

**Keywords** Human-machine interaction (HMI) · Interface evaluation · Eye movement technique · Work efficiency evaluation

### 29.1 Introduction

As the interaction window between the equipment and the operator, the human-machine interaction (HMI) realizes the transformation of the equipment information from the internal to that can be accepted by the operator. It is a vital component in the overall design of equipment, which may affect the play of the operation and combat efficiency [1, 2]. Traditionally, HMI evaluation, usually conducted by simulation test, user observation, or questionnaire, is not accurate in data and not reliable in objectivity due to lack of scientific basis. The eye movement technique may be employed in the human-machine interaction, by

---

C. Li (✉) · Z. Pang · Z. Ji · H. Li · H. Zhao · H. Wei  
Air Defense Forces Academy, Zhengzhou 450052, China  
e-mail: fkb\_mmes@163.com



observing the movement parameters of eyeballs, to evaluate the human-machine interface and thus provide an objective basis for optimizing the human-machine interface. In the recently developed expert-novice paradigm, the experimented personnel is divided into two groups: experts and novices. The eye movement data of the these two groups are collected and the difference is compared as far as the time of gaze, number of gaze point, and scanning trace are concerned in order to find out the experts' effective and practical scanning pattern and the novices' scanning drawback. The result is of great significance for directing the novices' skill training [3]. When the equipment HMI operation training, the direction of the eye movement pattern can be help the novice learn the experienced operators' effective eye movement distribution trace and foster a correct scanning habit, which may increase the training efficiency, shorten the training period, and help to adjust the equipment training contents.

## 29.2 Eye Movement Technique and Its Application

The human eye movement is the fast hopping movement between a series of staying points on the observed targets, which is usually categorized as three types: gazing, eye hopping, and eye tracking [5]. The eye movement technique is to track the eyeball movement and record its time/spatial data by detecting the relative movement of the position of the eyeball gazing point, such as the gazing time, number of gaze, incubation period of the eye hop, number of gaze back, size of pupil, and distance of eye hop. The analysis of the eye movement data can obtain the selection mode and the cognition feature of an operator's visually processed information and thus helps to learn the operator's distribution of attention and status of workload during the equipment manipulation [6]. As far as the human-machine interface and work efficiency are concerned, the eye movement technique may be applied in the following four aspects:

### (1) The Design of the Human-Machine Interface

The eye movement technique may be used to study the advantage and disadvantage of the HMI layout of the equipment and analyze its effect on the work efficiency of the equipment. The eye movement facilities may be used to measure the operator's eye movement during operation. Then, according to the eye movement data, the effect of the interface layout on the operator's cognition may be analyzed to provide a scientific basis for optimizing the human-machine interface.

### (2) The Operator's Achievement/Efficiency Test

When the operator's eye movement pattern is studied, the eye movement mode may be used to diagnose the operation drawback and evaluate the operation achievement/efficiency. Additionally, the comparison between the expert's and the

novice's eye movement modes during operation can not only provide reference for evaluating the operation achievement/efficiency, but also provide basis for formulating the operator's training program.

### (3) The Operator's Fatigue Test

During operation, an operator needs to concentrate his/her energy on monitoring all sorts of instruments for a long time, which may cause the fatigue of the physical functions of the brain and eye and result in the misoperation of the equipment and thus affect directly the combat training of the force. The eye movement technique may be used to evaluate and analyze the human-machine interface, deducing the degree of visual fatigue and the degree of cognition drop and thus quantifying objectively the corresponding workload and degree of fatigue.

### (4) The Operator's Distraction Test

During operation, an operator may be distracted due to the noise of alarm, artificial factors, and non-artificial factors, which may decrease the operation achievement/efficiency and increase the probability of error when serious. The eye movement technique may be used to measure and analyze quantitatively the distraction of the operator, so that the distraction may be detected as early as possible.

## **29.3 Eye Movement Technique-Based HMI Work Efficiency Evaluation System**

### ***29.3.1 Functions Realized by the System***

During evaluating and optimizing the human-machine interface, there are two major issues: first, "adapt the machine to the human," which is addressed at the stage of the equipment research and design in the closed loop "design-simulation-test-correct," where the data statistics and experience analysis is conducted, and thus consumes a lot of manpower and material; second, "adapt the human to the machine," which is addressed at the stage of the equipment finalization and field, where the variable room of the equipment is reduced, the human's plasticity must be brought to the full play to limit and train the operator so that the human may be better adapted to the equipment and the combat efficiency of the equipment be brought to the full play. At the same time, the design defects detected when the equipment is used should be reported to the industrial department for further optimizing the design and manufacture of the equipment.

The evaluation and optimization of the human-machine interface of the equipment are in fact to analyze the matching degree between the operator and such HMI elements as information display and widget layout. Different operators have different levels of understanding of the equipment internal structure and operation skills, which may directly affect the operators' ability to obtain

information from the human–machine interface and thus affect their ability to react during interaction. Due to the principle that the visual sense comes first, the operator must have an effective visual method to collect information. This will decide the quality of the subsequent information processing and the effect of the subsequent behavioral reaction, which is the basis for the match between the human and the machine. The visual search is a complex process of cognition and highly purpose oriented.

The eye movement technique may be introduced into the evaluation of the human–machine interface and the optimization of the operational procedure, and the visual search is brought to full play to the evaluation and optimization of the human–machine interface; thus, a corresponding evaluation experimental system may be developed. The system is based on the HMI ergonomics design standard and principle. It applies the eye movement technique to analyze the quantitative relationship between the amount of information provided by the human–machine interface and the visual-cognition reaction time; then, by combining the collected experiment data with the test of the HMI model, it evaluates the field of vision, visible area, tangible area, widget layout, etc., of the human–machine interface. At the same time, according to the result of the quantitative analysis, the system studies the HMI design defects and problems with the operational procedure and suggests the optimization or improvement scenario. The system may provide the following two major functions:

- (1) It solves effectively the issue that the human–machine interface is objectively evaluated.

The key to the evaluation of the human–machine interface is able to ensure the coordination and synchronization between the visual reaction and the operation feedback, so that the operator can learn rapidly and accurately all the status parameters of the equipment and the battlefield environment information from the human–machine interface and thus accomplish the combat mission with high efficiency. Therefore, the measurement and analysis of the operator's eye movement may collect such information as the position change and staying time of the gazing point on the human–machine interface; the recording of the movement sequence and the description of the trace may measure the effectiveness and reasonability of the HMI layout; as a result, the displayed density of visual sense may be decreased and the visual sense of balance may be increased as far as possible. The hot gazing point collected reflects directly the spatial distribution of the operator's eye movement trace and marks the length of the gazing time in the area concerned. The pulse of the eye movement trace may be used to analyze the affecting factors concerned and avoid the inconsistency of the interface layout.

- (2) It solves effectively the issue that the operational procedure is scientifically optimized.

When optimizing the operational procedure, the key issues to be addressed are rapid input, precise manipulation, clear information, and standard diagram. The operator's eye movement may be analyzed, especially the interval and sequence of

the gaze and hop, to optimize the operational structure and procedure by comparing and analyzing the operational procedure. The average number and average time of the gazing point may be calculated to indicate the reasonability of the HMI layout and the difficulty in displaying the information. As the rapid input, the operator's input actions should be so reduced to increase his/her work efficiency and probability of error. As for the precise manipulation, the manipulation to be easily mistaken and confused should not be interrelated and interweaved in order for the operator to prevent from committing errors and optimize the operational steps. As for the clear information and standard diagram, a corresponding improvement scenario should be suggested on the basis of the HMI evaluation and the system should be used to conduct a simulation test for the scenario in order to evaluate the effect of the interface improvement on the optimization of the operational procedure.

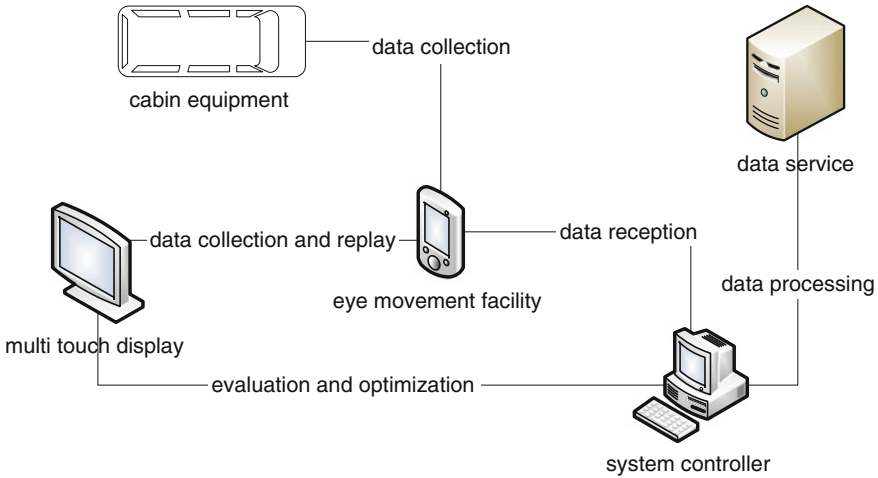
### ***29.3.2 Structural Composition of the System***

The system adopts the advanced eye movement technique to collect and replay the operator's eye movement status. By combining the dynamic display of HMI simulation model, the system analyzes the design defect and optimizes the operational procedure, constructs a corresponding HMI evaluation index, suggests the improvement scenario, and may replay the test. The overall structural composition of the system is as indicated in Fig. 29.1.

The system applies the eye movement technique and the CAD modeling technique. On the basis of the study of ergonomics, artificial intelligence, and data knowledge and in accordance with the operator's personal characteristics, operational capability, and behavioral features such as visual search and cognition capability, the system is to study the evaluation method and optimization principle of the equipment HMI layout. The Mobile Eye series eye tracker is used to collect and replay the data with the field of vision, hand manipulation, and eye tracking process during the operator's manipulation of the equipment HMI or the simulated HMI. The system controller and the data service are used to sort and analyze the collected data, and evaluate and optimize the HMI layout and operational procedure according to the operator's eye movement trace and related parameters.

#### **(1) Hardware Components**

The hardware of the system consists of the eye movement facility, multi-touch display, and computer. The eye movement facility is mainly used to collect the operator's eye movement trace. The display is mainly used for the dynamic display of the HMI simulation model in order to evaluate the HMI and optimize the operational procedure. The system controller and the data service are used to process the collected eye movement data and analyze corresponding gaze, hop, servo trace, and time, and size and distribution of the hot spot area and interference area.



**Fig. 29.1** Overall structure of the system

## (2) Software Components

The software of the system consists of the control software (self-contained software) of the eye movement facility and the HMI evaluation and optimization analytical software (self-developed software), as indicated in the block diagram shown in Fig. 29.2. The CAD modeling technique is employed to shrink or amplify the equipment HMI in proportion; construct the simulation model and the simulation operational environment of the equipment HMI together with the relative affecting factors such as light, weather, and noise; and expand the application function of the evaluation experiment.

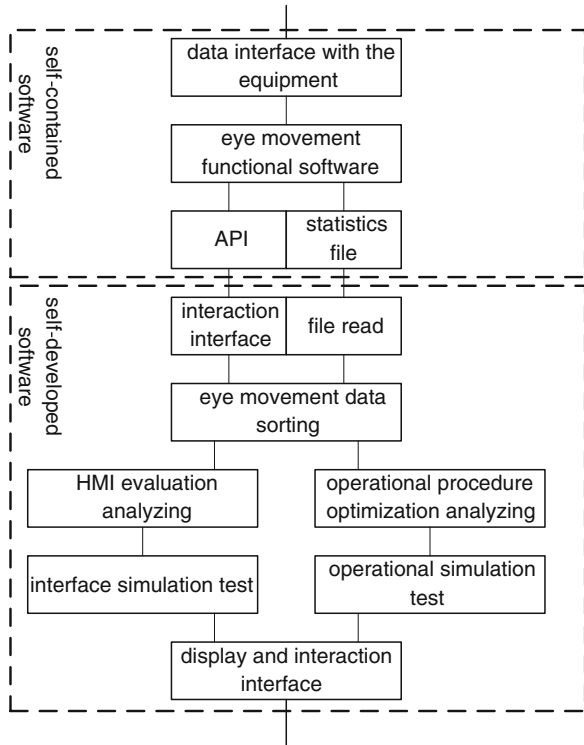
### 29.3.3 Prospect of the System Application

The system may be used to enhance effectively the capability to study the equipment HMI, transforming from the traditional empirical statistics to the combination of qualitative and quantitative studies.

#### (1) May serve the industrial department for research and demonstration

With the increasing digitalization and automation, the weapon and equipment are more and more dependant on the human-machine interface. The human-machine interface of the early weapon and equipment is designed by its research and development personnel, who often understand the manipulation of the equipment from other perspective than the operator with the troops. This may bring difficulty for the manipulation of the equipment, restricting seriously the full play of the combat efficiency of the equipment. To solve such problems, the industrial

**Fig. 29.2** Software structure of the experimental system



department dispatches its representative to the troops to learn and guide the manipulation of the equipment, but this cannot solve the problem absolutely. The eye movement technique embeds the HMI evaluation index system into software, evaluates the HMI automatically, and produces a corresponding evaluation report after quantitative and qualitative analysis, which may enhance the pertinence of the industrial department in designing the equipment HMI.

(2) May serve the military institutions for standardizing teaching and learning

In the training of the cabin equipment, the military institutions carry out the manipulation standard strictly adopting the normalized guidance as the major mode, which restricts the cadets' initiative. In the equipment practical training, the cadets may master the basic operational procedure, but the manipulation steps are rather rigid and cannot match the HMI well, which affect seriously the play of the human-machine adaptability. The eye movement technique may be used to monitor the operational procedure; by way of exchange and discussion, the degree of match between the individual cadet and the cabin HMI may be analyzed; according to the personal situation, the corresponding operational procedure may be optimized to enhance the efficiency of the equipment; the individualized equipment training may thus be realized.

### (3) May serve the field troops for scientific training

In order to generate the combat power as soon as possible, the industrial department usually dispatches its representatives to the troops to guide the training on the site after the cabin equipment is fielded. At present, the operators in the troops are mainly non-commissioned officers. Due to the difference in knowledge and skill, they have a great different understanding of the equipment HMI and operational procedure with the assumption of the industrial department. Therefore, the system can evaluate and analyze the standard operational procedure of the equipment and result in an optimized standard operational procedure. Then, the system may compare with the operators and analyze the individual difference to suggest an optimized scenario. Finally, the system may join the operators' guidance and analysis loop in the troops' cabin equipment training, so that the troops may be equipped with the capability to optimize the HMI design and operational procedure; thus, the troops may feed the quantitatively analyzed improvement scenario back to the industrial department for enhancing the pertinence to update and modify the equipment.

## 29.4 Conclusions

Based on the human-machine interface, the research and development of the system is to employ the eye movement technique to construct scientifically a cabin HMI model and further study the interrelationship between the factors "human, machine, and environment," so that the equipment design is more humanized and scientific, and the operator can be more comfortable and rapid to acquire the concerned information satisfying the requirement of the human-machine adaptability. The research and development of the HMI interactive work efficiency evaluation system based on the eye movement technique can provide a scientific guidance for the optimization of the HMI design and operational procedure of the equipment for the future war.

## References

1. Zhi-bing P, Hong-lei L, Dong L et al (2011) Human-machine-environment system engineering theory and core military competence building. The 11th human-machine-environment system engineering symposium, Publishing House of Electronics Industry, Beijing
2. Zhi-bing P et al (2009) ADF human-machine-environment system engineering. Air Defense Forces Academy, Zhengzhou
3. Zhong-qi L, Xiu-gan Y et al (2009) Comparison of expert and novice eye movement behaviors during simulated landing flight. *Space Med Med Eng* 22(5):358-361
4. Wetzel PA, Anderson K, Gretchen M et al (1998) Instructor use of eye position based feedback for pilot training. *Hum Factors Ergon Soc* 2(5):5-9

5. Hai-yan W, Bian T, Cheng-qi X (2011) Experimental report of the fighter display interface layout based on eye movement tracing. *Electron Mech Eng* 1227(6):50–53
6. Tian-jiao L, Zhen-shan L (2013) Eye movement research of the pilots in different flying time of simulated orientation mission. *Chin Aerospace Med*, vol. 24, No. 1, Dec 2013
7. Zhi-bing P, Yong Z, Hong-lei L et al (2012) On the construction of the human-machine-environment system engineering laboratory. The 10th military institution laboratory construction and development symposium, Publishing House of National Defense Industry, Beijing, p 6



# Chapter 30

## Ergonomics Evaluation Methods of Cockpit Lighting in Aircrafts

Duanqin Xiong, Xiaochao Guo, Wang Hong, Chunmei Gui, Guowei Shi, Bai Yu and Du Jian

**Abstract** This article summaries the ergonomics evaluation methods of cockpit lighting in aircrafts, aiming to reflect the general status in this domain. As for the evaluation methods, it is mostly that in the different design and development phases, basing on some standards, specifications, and technological files, the evaluation primes to lighting devices such as displays and lights, some instruments are applied to measure and test the luminance, illuminance, chromaticity, and NVIS radiance. Contact evaluation is of small proportion. Only in China, pilots' objective integrated evaluation is applied to the cockpit lighting with civil aircrafts. Due to the task particularity of civil aircrafts, only safety and comformability are evaluated.

**Keywords** Cockpit lighting · Ergonomics · Evaluation methods · Aircrafts

### 30.1 Overview

Light environment in the cockpit can be divided into two categories: ambient light outside the cockpit and artificial light in the cabin. Ambient light mainly refers to the sunshine during the day, while laser and signal light, etc., light sources used on the ground at night. Artificial lights mainly refer to lights generated by dome lighting, flood lighting, integrated panel lighting, alarm lighting, push button switch lighting, and multi-function lighting. In the static and dark modes, the artificial lights mainly refer to those generated by the guide light board illumination and instrument illumination [1].

---

D. Xiong (✉) · X. Guo · W. Hong · C. Gui · G. Shi · B. Yu · D. Jian  
Institute of Aviation Medicine, Beijing 100142, China  
e-mail: xdqin123@163.com

Cockpit light environment affects the flight safety. By changing glare, cabin lighting color, contrast ratio, brightness, and its uniformity, these factors generate impacts on the pilots' visual observation.

The purpose of the ergonomics design of cockpit lighting is to minimize or avoid various effects on the pilots caused by the adverse light environment. It helps pilots to quickly adapt darkness, accurately display information as well as locate the positions and height of the aircraft, improve the efficiency in observation and manipulation, ensure the furthest flight safety through various measures, such as preventing glare, increasing dimmable light in the cockpit, choosing lighting with the right color temperature, etc. To the designed and developed cockpit lighting system, ergonomics evaluation should be made for the cockpit lighting about the lighting effect, compliance to the pilots' needs, and improvement of use efficiency. This paper reviews domestic and foreign lighting methods used in the aircraft cockpits to reflect general situations in this field.

## **30.2 Foreign Assessment Methods**

From the search results of the literature, there are several foreign standards, specifications, and documentation, which regulate the detection and evaluation of lighting effects in the aircraft cockpit.

### ***30.2.1 Test and Evaluation on the Aircraft Lighting in MIL-STD-3009 [2]***

The US Military Standard MIL-STD-3009 (2001) Lighting, Aircraft, Night Vision Imaging System (NVIS) Compatible, give methods for detailed test and evaluation whether the aircraft lighting system meets the design requirements. Its main contents include: system-level test, inspection conditions and order, lighting conditions, check before starting the test, testing, inspection methods, and procedures. In the inspection methods and the procedure, specific methods are regulated, respectively, including visual inspection, night vision imaging test, brightness uniformity, cockpit reflection, visual test, operation, brightness and luminance measurement, chroma measurement, luminance measurement assisted by spectrum, light leakage inspection, etc.

Although there is some visual evaluation, test and evaluation methods for the night vision lighting compatibility regulated by the standard mainly focus on the objective tests. Standardized tests and evaluations have been done aiming at all lighting systems, subsystems, and lighting components and equipment, based on the compatibility evaluations of the NVIS.

### ***30.2.2 Validation and Evaluation of Aircraft Lighting in JSSG-2010-5 (1998) [3]***

JSSG-2010-5 (1998) Crew Systems Aircraft Lighting Handbook stipulates verification requirements for aircraft lighting systems, they are suitable for all systems, subsystems, components, equipment, and hardware, which provide lighting environment for the aircraft cabin. Validation (check/analysis/demo/test) mentioned here should demonstrate the ability for internal and external lighting equipment to meet requirements. All verifications should be responsible for the contractors, and the government is entitled to witness or carry out all verifications.

There are four kinds of verification types: analysis, demonstration, inspection, and testing. In the verification process, there is process control.

In the development of aircraft lighting systems, checks for each stage mainly include: system requirements, system function, preliminary design, critical design, first flight inspection, functional configuration, and system verification.

A variety of ground tests should be carried out in four stages, including concept demonstration and validation, engineering and manufacturing development, production and scheduling, operation and protection, etc. Flight tests should be conducted at the end of each stage.

This specification is primarily used in all stages of the aircraft design and development, analysis, check, demonstration, and test. Verification works have been done on the illumination system and equipment and then let the final cockpit lighting meet the design requirements.

### ***30.2.3 Compatibility Evaluation Method of the Night Vision Imaging System Illumination [4]***

There are several special means to interfere with the normal operation of NVIS in the cockpit lighting. In each of the interference mechanism, effects on the imaging of night vision are reduction in light levels or contrast ratio of useful images. Such reduction can be proved by decreased visual acuity and/or loss in contrast degree or brightness. Nowadays, there are several methods in the world, which can evaluate compatibility between the cockpit lighting and night vision goggles.

#### **30.2.3.1 Measurement Methods of Photometric and Radiation Standards**

More than 30 years has passed since the US Air Force, Army, and Navy use NVG in the flight. One of the important issues is the compatibility of the cockpit lighting and NVG. Finally, the military formulated performance standards, which are relatively easy to perform but with very high cost, so as to evaluate whether the

cockpit lighting is compatible with NVIS. The most basic assumption for this standard is under certain lighting levels, the brightness of any light source shown in the NVG cannot be greater than the brightness of natural starlight. A variety of cockpit lighting sources' photometric and radiometric criterion is generated on this basis. NVIS radiance is the displayed emissivity regulated by the NVG' spectral response curves.

### **30.2.3.2 Visual Acuity Method**

The second evaluation method is visual acuity method. Trained evaluators sit in the cockpit in this method, while the aircraft is parked in the dark shed with controlled lights. The visual acuity meter is placed 20 ft away from NVG, illuminating until the NVG radiation is  $1.7 \times 10^{-10}$  W/cm<sup>2</sup> sr. Cockpit illumination level is adjusted to the operational level, so as to be convenient for evaluators to observe. Evaluators then measure visual acuity with the turning on and off of the cockpit lighting system. If there is any reduction in visual acuity between the on and off conditions, the lighting system is considered to not meet the requirements. Equipment or tools required by the visual acuity method include: visual acuity meter, illumination measuring device, radiation measurement method of the visual acuity meter, as well as test method to judge whether darkness in the test environment meets the test requirements.

### **30.2.3.3 NVG Light Output Method**

The third method is directly measuring amount of the interference light caused by the cockpit lighting and display, which is called NVG light output method or NLO method (NVG light output). That is when measuring cockpit lighting and under both conditions to displace "on" and "off," amount of incensement in the NVG light output. The excessive light output will cause interference in NVG, and therefore, it is related with the decrease in NVG image quality. Cost of the luminance meter used in this method is not high, and usage of the luminance meter is divided into two forms of absolute and relative light levels standards.

### **30.2.3.4 NVG Objective Lens Irradiance Method**

The fourth method to evaluate the NVIS illumination compatibility is NVG objective lens irradiance method. The irradiance meter used in this method is the absolute light level standard, but the NVG objective lens is covered with a piece of diffusing plastic material. The objective lens is adjusted to the minimum focal length. In the case of all lighting in the cockpit is switched off, write down basic values of the NVG/photometer, and then turn on all cockpit lighting, write down

the second value. If the results got by subtracting operation of the two values, and if the result is equal to or less than the value specified, it is considered that cockpit lighting has compatibility.

### **30.3 Domestic Assessment Methods**

#### ***30.3.1 Military Aircraft***

More than ten national military and industry standards have been drawn up, aiming at requirements and test methods for the military aircraft cockpit lighting at home.

Some standards [5] specify the basic technical requirements, test methods, and items for the cockpit lighting, aiming at the basic technical requirements of brightness and chroma in the cockpit illumination, which takes incandescent and electroluminescent as light source. These standards involve individual instrument and single-light guide plate, including visual inspection and objective test. The objective test mainly tests cockpit's illumination, lighting uniformity, diffuse reflectance coefficient of the markers and background surface, contrast between the mark and background, scattering light of the instrument lighting, etc., indicators.

Some standards [6] specify requirements of the overall layout, performance, and inspection of the aircraft's lighting. These standards also specify the validation to the interior and exterior lighting subsystems, respectively. By adopting objective measuring means, these validations test the lamination chroma, brightness, NVIS radiance brightness, contrast, etc. Visual inspections are also included to some index, such as reflective glare, etc., and subsystem verification provisions made, the objective is to take these tests to verify the main means of lighting color, and other indicators for testing, but also includes some indicators check visually.

There are industrial standards at home, which specify the measuring methods specialized in the red and white light illumination. These standards are basically same as above several military standards.

#### ***30.3.2 Civil Aircraft***

In our country, the designers have taken subjective assessments to some extent as the model for sample analysis, assessed the cockpit lighting effects, and drew fruits in safety and comfort of design in the cockpit lighting [7]. Concrete practices include:

1. Determine the assessment factors, mainly including assessment objects and personnel, test environment, assessment procedures, and compliance criterion.
2. Determine the assessment objects, mainly including the cockpit overall lighting effect, glare, light guide plate lighting, and display systems lighting.

3. Determine the assessment personnel. The evaluators mainly include professional pilots, flight engineers, and lighting ergonomics experts.
4. Requirements for test environment. Tests must be done during two environmental conditions, namely day and night, and carry out in the real cockpit, with the controlled environmental brightness, extreme conditions can be simulated by external sources.
5. Evaluation process. It mainly includes creating environment in the cockpit, assessing all contents, etc.
6. Compliance criteria. Assessment results should be analyzed and processed from the safety and comfort.

### 30.4 Summary

Viewed from foreign and domestic ergonomics assessment practice for aircraft cockpit lighting, the method mainly focuses on different stages in lighting design and development, based on certain standards, specifications, and technical documents, focusing on various lighting equipment. Use the luminance meter, colorimeter, and illuminometer, etc., to do objective measurement of brightness, color, auxiliary brightness, and illumination, etc. Visual evaluation only accounts for a very small proportion. But only in China, pilots' subjective evaluations are mainly adopted for civil aircraft cockpit lighting.

### References

1. Wei W, Sun Y, Lin Y Effect on flight safety of light environment in cockpit. [http://d.g.wanfangdata.com.cn/Conference\\_7453437.aspx](http://d.g.wanfangdata.com.cn/Conference_7453437.aspx)
2. MIL-STD-3009 (2001) Lighting, aircraft, night vision imaging system (NVIS) compatible
3. JSSG-2010-5 (1998) Crew systems aircraft lighting handbook
4. Task HL, Pinkus AR, Barbato MH et al (2003) Night vision imaging system lighting compatibility assessment methodology. Hum Factors Vertical Flight Prog Rev FY03 4–8
5. GJB 455-1988 Basic technical requirements and test methods for aircraft cabin lighting
6. GJB 2020-1994 Lighting, aircraft interior and exterior, general specification for
7. Xia H, Zhu Z (2012) Evaluation method for cockpit lighting of civil aircraft. Technol Mark 19(10):12–13

**Part V**  
**Research on the Man–Environment**  
**Relationship**

# Chapter 31

## The Analysis and Research on the Design Concept of the Agile Pilot Clothing System

Guangjun Feng, Feng Qiu, Yubin Zhu and Haibo Zhang

**Abstract** The Agile pilot flight equipment (PFE) garment which is developed by the RFD Beaufort is the most advanced personal protective equipment for the pilot. It can be used in complement with the advanced aircraft such as Joint Strike Fighter (JSF), F-16, or F-18. Each function item of traditional PFE garment has been modularized and integrated in accordance with the mission profiles of the pilot to meet the requirements of the combat mission. This paper details the Agile PFE garment and takes example for interfacing with the JSF (hereinafter referred to JFS). The configuration characteristics, operational performance, and design concept of each module and their complement have been analyzed systemically, which shows the applied design concepts about the Occident PFE and provides references for our country on the technical integration and product development of various JFS PFE in future.

**Keywords** Agile · Clothing system · Design concept

### 31.1 Brief Introduction to Agile Pilot Clothing System

The Agile pilot clothing system which is researched and developed by RFD Beaufort Company and the Mark-Ark underwater escaping and lifesaving system are honored as two innovations with revolutionary significance in the industry. It is the most advanced individual protection clothing system for pilot, and it has been provided to aircrafts such as JSF, F-16, and F-18 to use successfully.

The protective features of the Agile pilot clothing system include the functions such as overload protection, altitude protection, thermal protection, fire protection, biochemistry (CB) protection, ejection from aircraft in high speed,

---

G. Feng (✉) · F. Qiu · Y. Zhu · H. Zhang  
Aerospace Life-Support Industries Ltd., Xiangfan, China  
e-mail: 625215485@qq.com



lifesaving on sea, and lifesaving on land. It has good comfortability and excellent maneuverability.

The modular design and the interchangeability design of each component of the Agile pilot clothing system can meet the requirements of different flight missions and operations. Take the Agile pilot clothing system matched for JSF as the example, see Table 31.1 for the matched components.

The Agile pilot clothing system has comprehensive protective properties and good comfortability, while strengthening the overall performance of the pilot, it can provide the optimized protections which mainly include the following:

1. Reduce the pilot fatigue;
2. Improve the situational awareness of the pilot;
3. Low maintenance cost;
4. The protection module can be cut out to meet requirements for different missions.

## **31.2 Analysis on Features of Agile Pilot Clothing System**

### ***31.2.1 Design Concept***

From the underwear to the outerwear, the Agile pilot clothing system has comprehensively and systematically provided the garments for pilot (see Table 31.1); the garment combinations are divided for four main flight mission protection, namely for summer (on land/on sea), for summer CB, for winter on sea, and for winter on sea CB, and it reflects the design concept of “modular design, selective combination, and targeted protection.”

### ***31.2.2 Chest Compensatory***

In a general way, to provide counterpressure for chest under PBA and PBG to reduce the deposition of blood in trunks to prevent lung injury because of breathing under high pressure, providing a chest compensatory airbag is undoubtedly right from the physiological angle. The Agile pilot clothing system for JSF is provided with a chest compensatory airbag as the initial design; however, the chest compensatory airbag is removed later, and the reasons are as follows:

William Albery and others in the US Air Force Test Laboratory have researched the anti-overload effect of removing the chest compensatory airbag in COMBANT EDGE and the research shows the following:

**Table 31.1** The standard accessory products of the pilot clothing system of the JSF

Garments	Summer (land/sea)	Summer CB	Winter sea	Winter sea CB
Socks	√	√	√	√
Underwear lower	√	√	√	√
Underwear upper	√	√	√	√
Cooling garment (worn in place of underwear upper)	Optional	Optional	Optional	Optional
Thermal protection layer	–	–	√	√
Lightweight coverall (ARS)	√	–	–	–
Cold water immersion garment/socks	–	–	√	√
Flight use Chem. Bio. protective layer	–	√	–	√
Lower G garment (option to use skeletal or full coverage garments)	√	√	√	√
Sleeved flight jacket/LPU/ARS	–	√	√	√
Sleeveless flight jacket/LPU	√	–	–	–
Breathing gas hose assembly	√	√	√	√
Boots	√	√	√	√
Summer gloves (worn for all flying operations)	√	√	√	√
Winter/sea gloves (stowed in the SSK and donned post-ejection)	–	–	√	√
Transit use Chem. Bio. protective layer	–	As required	–	As required
HMD transit bag	Optional	Optional	Optional	Optional

1. The anti-overload effects of PBG in COMBAT EDGE with and without the chest compensatory airbag are almost the same [1];
2. There is obvious thermal load when there is a chest compensatory airbag, and it is easier to fatigue [1].

In addition, considering the effect to altitude protection, the physiological effect analysis of PBA without chest compensatory airbag to human body:

1. In European's opinion, the warplanes usually fly in low altitude in present air war; for the warplane whose altitude limit is 18,000 m (for example, the altitude limit for JSF is 18,288 m), the provided individual equipment can only guarantee the safety of lifesaving in 15,000 m. The probability for cabin decompression in high altitude is low, and it is only about 1/100,000. This is the main basis;
2. With regard to provide counterpressure on body surface, adding pressure to anti-G suit in PBA is also a good compensatory way which can increase the returned blood volume and the cardiac output while enhancing the effective circulating blood volume in body.

3. The Europe and America initiate simplified oxygen supply device to reduce the physiological load. When the cabin blasts in high altitude, it can provide protection for lifesaving in a short time to “let you fall” to exert the performance characteristic of aircraft to maximum.

### ***31.2.3 Anti-G Suit***

The anti-G suit matched to the Agile pilot clothing system for JSF can be a five-bag-type anti-G suit and a fully covered anti-G suit. The RFD Beaufort Company has reported the anti-G effect of the Agile pilot clothing system as shown in Fig. 31.1

NP-no protection; C5BAG-5-bag-type anti-G suit; FAGT-fully covered anti-G suit; C5BAG&PBG-5-bag-type anti-G suit + positive pressure breath; FAGT&PBG fully covered anti-G suit + positive pressure breath.

As shown in Fig. 31.1, when there is no protection and the basic anti-G effect of human is 3.5 G, the comprehensive anti-G effect of FAGT&PBG is 8.5 G, and the comprehensive anti-G effect of C5BAG&PBG is only 6.3 G. From this aspect, FAGT is better than C5BAG.

Then, why doesn't the Agile pilot clothing system use FAGT directly while adding an option for C5BAG? The thermal load of FAGT is the biggest defect. FAGT covers the lower body totally (the covered acreage of the lower body exceeds 90 %), the airtight anti-G caplets prevent the heat dissipation of legs, and it brings serious thermal load for human body. Sowood and other people in United States Air Force have researched the heat stress of pilots equipped with different anti-G suites to fly under warm climate. They have compared the thermal loads of C5BAG and FAGT with chest compensatory bag, and the results indicate that when the WBGT in the cabin is less than 25 °C, even decreasing to 15 °C, the average skin temperature of pilot equipped with FAGT with chest compensatory bag is increased obviously and it exceeds the upper limit for comfortability (35 °C). Obviously, under the warm climate, the heat stress of FAGT is more obvious than that of C5BAG. The heat stress may cause many problems for pilot such as fatigue, failure to concentration, decrease of overload resistance endurance, and dehydration. In hot summer, when the pilot is preparing, sliding, and flying in low, it is difficult for the environment control system of aircraft to guarantee the comfortability of human body in FAGT. However, the crotch and the knee are exposed out when equipping with C5BAG and the acreage of covered lower body is about 30 %, so the thermal load is obviously smaller compared with FAGT. Thus, the C5BAG is the option of anti-G suit when the climate is warm and the craft flies in low.

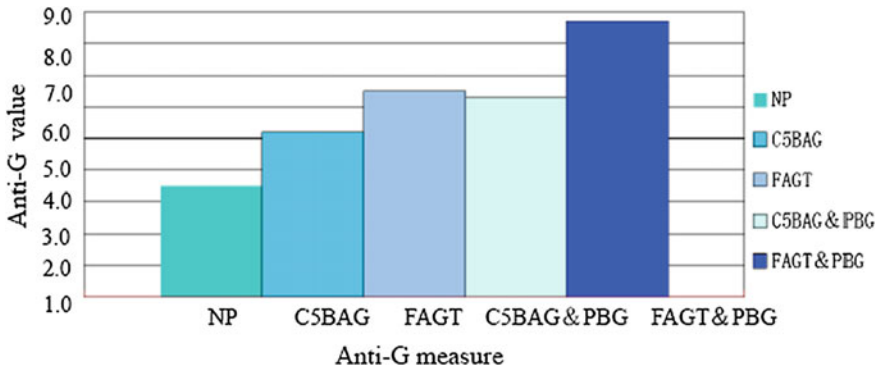


Fig. 31.1 The comparison chart of the anti-G effects of the different pilot clothing

### 31.2.4 Anti-Exposure and Cold-Protective Clothing

The anti-exposure and cold-protective clothing matched with the Agile pilot clothing system are divided into anti-exposure suit and cold-protective clothing. Its mating and structural features mainly are as follows:

1. The anti-exposure suit is designed as single-layer structure, and it is arranged in the inner layer of the anti-G suit.
2. The cold-protective clothing is very light, and the inner layer of the cold-protective clothing is only provided with cotton knitwear for summer

The cold-protective clothing is divided into 21 types, and the anti-exposure suit is divided into 19 types. The cold-protective layer is designed very light, and it is comfortable to wear; it is as thin as single cloth after stressing, so it can decrease the big wrinkles in the anti-G suit and prevent pressing pain caused by wrinkles when pressing the anti-G suit. It almost does not affect the decompression value and the decompression speed of anti-G suit.

The design for the anti-exposure and cold-protective clothing for pilot shall consider not only the suitability for comparatively hot ground but also the life-saving when falling into cold water. Usually, it can guarantee the common healthy mature male to stay in the cold water in 0 °C for 6 h when being provided with 0.75 clo thermal insulation cloth in cold winter. The research report of Mustang lifesaving company shows that the thermal insulation effect of 0.75 clo of the anti-exposure and cold-protective clothing in cold water equals to the thermal insulation effect of 1.6–2.0 clo in quiet cold air; the anti-exposure and cold-protective clothing for European and America pilots usually provides thermal insulation of 2.0 clo in quiet air [2].

Obviously, a set of anti-exposure and cold-protective clothing which can provide thermal insulation of 2.0 clo in quiet air can guarantee common pilot stays in

cold water of 0 °C for 6 h. While the pilot is ejected out, the signals for helping is also sent out. Then, the maritime search and rescue can be finished in 3 h [3].

That is why the anti-exposure and cold-protective clothing for the Agile pilot clothing system is designed so light.

### ***31.2.5 Cooling Garment***

The cooling garment of Agile pilot clothing system takes the waistcoat with liquid cooling (optional) instead of ventilated waistcoat matched for F-22 fighter; the reasons are as follows:

The cooling efficiency of water cooling is higher than that of air cooling because the thermal conductivity of water is 24 times of that of air. The American Nunneley indicates that the cooling effect good enough can be reached when covering the partial body with the brief water-cooling garment in cabin. The head and the trunk of body are usually regarded as the best parts for water cooling. The liquid-cooling waistcoat is mainly used to cool the trunk of body, and the truck takes more than 30 % of the body surface area where there are the most radiant heat. From the physiological point of views, it is a suit for heat exchange.

In addition, when wearing the matched anti-exposure suit, the liquid cooling is more ration than air cooling. The air cooling adjusts the temperature by the air whose temperature is adjusted blows to the skin through many holes faced to the skin on the ventilation tree (vent lines arranged near the body). The vent flow usually is 200–400 L/min. The anti-exposure suit is a garment that covers the whole body, and the gas permeability of the cloth is only 0.09 L/m<sup>2</sup> min, so it is almost airtight. If the ventilation garment is worn in the anti-exposure suit, the air blown to the skin is deposited in the garment and cannot be discharged out. To discharge the air in the garment, it is must to provide a vent valve in the anti-exposure suit; however, it has great disadvantage to arrange a vent valve on the anti-exposure suit wear inside; meanwhile, the air in the garment shall affect the mobility of the pilot. It can be imagined that compared with the air cooling, the water inlet and the water outlet of liquid-cooling waistcoat are closed and circulatory, so there is no similar venting problem.

### ***31.2.6 ASR Design***

Under the condition of ejection in high speed, the blast of strong airflow shall have a strong dynamic pressure on the human body. For example, when the airflow of 1,000 km/h is blasting on the seal level, there shall be lift force of 2,100 N and resistance of 1,580 N working on the arms to force the arms moving to the opposite direction from the original “string” position. Thus, to prevent injures due to falling down, when ejecting in high speed, it is must to take measures to limit

the outward movement of two arms. The Agile pilot clothing system is provided with arm string ring (ASR) which is arranged on the light garment for air duty and the lift vest, and it is suitable to use in summer and winter. When the pilot starts the central pull ring in the ejection seat, the personal movement limit system on the seat is started immediately and the two arms are “dragged” tightly to limit them move outward. Compared with the way of Russia to use arm-limit device, one is to “drag” initiatively and the other is to “block” passively. The structural design of “drag” is easier, it is limited actively, and it works before the airflow, so it is better for protection.

### ***31.2.7 Life Vest***

The life vest in the Agile pilot clothing system is provided with LPU unit, attached lifesaving bag, and all guidelines and attached hanging points for pipeline.

#### **1. LPU Unit**

To meet the requirements of many flying environments, LPU and the main body of life vest take the detachable design, namely install it when flying on sea and detach it when flying on land to reduce the load of personnel effectively.

The back neck of LPU is provided with a fixing band which is connected on the string band on the waist to prevent contacting with the helmet system. The LPU airbag is provided with a reinforcing cloth to improve the stress structure and increase the reliability to prevent the blasting of air bag in high altitude [4].

#### **2. Attached Lifesaving Bag**

The left and the right parts on the front chest of the life vest in the Agile pilot clothing system are provided with series of hanging band which can be used to hang all kinds of lifesaving bags to guarantee the pilot can escape smoothly without any other additional actions when leaving the aircraft under emergency to save the escape time for pilot under emergency effectively. The water attached on the life vest is provided with a sucker to allow the pilot to suck at any time while considering the requirements of the pilot for water when flying for long time.

### ***31.2.8 Oxygen Supply Pipeline Subassembly***

The oxygen supply pipeline subassembly is used to connect the oxygen mask and the oxygen source. The oxygen supply pipeline subassembly of Agile pilot clothing system is attached on the life vest as an individual unit.

When the cabin exploded and decompressed in high altitude, the gas in lung of human should be discharged quickly to reduce the decompression peak value of lung and shorten the detention time of decompression peak value to decrease the lung injury of human. The decompression valve is arranged to “provide” area to discharge pressure at the moment of explosive decompression when the gas in the chest bag fails to enter the oxygen pipeline.

### ***31.2.9 Chemical Protective Clothing***

The chemical protective clothing of Agile pilot clothing system is divided into chemical protective flight clothing and chemical protective and isolating layer for boarding on ground/deplaning. The chemical protective flight clothing is used to wear when flying across biochemical-contaminated area, and the chemical protective and isolating layer for boarding on ground/deplaning is used to wear when walking, boarding/deplaning on the biochemical-contaminated area to separate the human body with the biochemical contaminant.

To help the pilot boarding to fight and deplaning under heavy biochemical pollution on ground, the chemical protective and isolating layer for boarding on ground/deplaning is made of totally airtight plastic film, so it is suitable for walking on ground in short time, and the practicability is emphasized.

### ***31.2.10 Experimental Verification***

The main qualification tests for the Agile pilot clothing system include 600 KCAS (1,100 km/h) speed ejection and airflow blast, explosive decompression, dynamic human and chair separation, parachute hanging, water diving and landing dragging, environment and laboratory test, pool test, burning test, falling water/landing thermal protection test, cooling test, NBC test, rescue exit, cabin adaptation, normal deplaning on ground, deplaning under emergency, human and aircraft analysis, centrifuge test, and hypobaric chamber test.

It can be seen that RFD Beaufort Company has carried out fully experimental verifications for the Agile pilot clothing system, including the protective properties in cabin, the protective properties for deplaning, and the lifesaving properties for water diving/landing. The Europe and America have comprehensively considered and systematically verified the protection and the lifesaving stages for pilots. The projects such as water diving and landing dragging test, the burning test for the system and normal deplaning on ground/deplaning under emergency are not taken into consideration when verifying the pilot clothing system in early time in our country, and it is worth learning.

### 31.3 Conclusions

This paper has introduced the Agile pilot clothing system which is regarded as the most advanced international pilot protective clothing system by the industry and has analyzed its design. We summarize the design concepts and the features of the European and American pilot protective clothing through the analysis as follows:

1. Stick to the training and the real environmental situation for actual combat and consider the protection and the lifesaving systematically;
2. Modular design, combine according to the mission profiles, and the protective pertinence is strong;
3. Give up the protection in small probability, simplify the equipment, and pay attention to the comfortability and the mobility;
4. Fully verify the protection and the lifesaving in each stage such as boarding, in cabin, deplaning, water diving/landing, and the practicability is strong.

These analysis and conclusions can provide references for the technology integration and product development of protective clothing for pilots driving all kinds of fighters in our country to some extent. It is worth mentioning that although we have briefly been analyzing the Agile pilot clothing system through collecting all kinds of materials and learning and clearing up these materials, we still are unfamiliar with the design for details, the test methods, and the performance assessment criteria of Agile pilot clothing system. So we suggest the domestic units with related business carry out the technological cooperation with the RFD Beaufort Company in the UK through all kinds of channels to learn the design essence of advanced clothing system truly to inject power for the development of individual protective equipment for the pilot of our country.

### References

1. Albery W Avitation safety in the rapid onset, high-G environment, AFRL-HE-WP-TR-2006-0025
2. Uglene W Recent advances in protective clothing technology, ADP012407
3. Wang H (2010) The brief introduce on Chinese marine rescue. The Navigation of Tianjin, vol 3
4. Wu B (2009) The brief introduce on buoyancy and effect of the life jacket. The Aviation Life-Saving of China, vol 1



# Chapter 32

## Effects of Color Rendering Index of Light Source on Color Task of Comparison and Fast Identification

Jie Li, Weihao Yang and Sugang Wang

**Abstract** *Objective* Color rendering property of light source will have effect on the color showing of the irradiated object, affecting the task of color identification. The experiment was developed to supply reference gist for illuminance ergonomics design. *Methods* Four light sources with different color rendering index (CRI) were chosen. The color tasks of comparison and fast identification were designed. The data of right ratio and error degree were analyzed. *Results* When light source's CRI is above 70, it will not have evident effect on color tasks of identification and comparison. *Conclusion* Light source's CRI should be above 70. Special CRI should be taken into account besides the average CRI.

**Keywords** Color rendering index · Color comparison · Fast identification of color · Error degree

### 32.1 Introduction

Along with the continuous escalating of manned space mission, the astronauts will take part in a growing number of scientific experiments and work, which raises higher requirements for the light source lighting design of the aircraft. Lighting design and evaluation have developed from the past, which takes illumination level as the main indicator, to the present composite indicators taking comfort as the basis. Among them, the color quality of the light source is one of the main indicators to determine lighting effects, and color rendering of the light source is an important indicator to evaluate the color quality of light source. Color rendering of the light source refers to the degree to which objects show color rendering consistency in the measuring and reference light source; the spectral distribution of

---

J. Li (✉) · W. Yang · S. Wang  
China Astronaut Scientific Research Train Center, Beijing 100094, China  
e-mail: shibazi\_carol@163.com

the light source determines color rendering of the light source. During the past few decades, color rendering index (CRI) developed by the International Commission on Illumination (CIE) is a commonly used color quality evaluation index [1–3].

In fact, there are limitations to use a single CRI to analyze quantitatively color rendering of light source; color quality of light source is determined by the visual experience of people when they complete specific tasks [4, 5]. Color rendering of the light source has different impact on the tasks with different nature of the task. In general, the visual color tasks include color distinguishing and recognition; the former mainly tests the human eye's capabilities to perceiving, distinguishing, and comparison of color, while the latter studies memory and recognition capabilities of people to the color. This paper firstly studies the influence of light source with different CRI on the ability of the human eye to observe color. Secondly, the influence of light sources with different CRI to the color was studied; aiming at in an emergency or malfunction conditions, astronauts often need to complete the color recognition task in space missions.

From the current point of view, the color identification ability and the color adaptability identifying are more considered [2], but there are few researches on the color rapid identification. That is, color identification can be divided into color identification in long-term and short-term memory, according to the memory source of control tone. Color identification under long-term memory is based on persons' cognitive characteristics and capabilities to color formed for a long time, while the identification of short-term memory is the color cognition characteristics and ability formed in a short period of time. Both reflect persons' memory and recognition of color from different angles. At present, there are more researches on color identification under long-term memory [2]; this paper mainly considers color rapid identification ability under short-term memory.

In summary, this paper studied the influence of light source with different CRI on the human eyes' color matching and the ability to quickly identify the color, so as to guide manned space missions, as well as the design of color rendering of light source in other emergency or malfunction conditions.

## **32.2 Method**

### ***32.2.1 Experimental Equipment***

The experiment selected the two sets of light sources with 4 kinds of CRI (Ra); Ra was 90, 80, 70, and 60, respectively, light source 90 is as the control source, and light sources 80, 70, and 60 were used as those to be detected. The equipment also includes the following: 2 sets of experimental color cards (conforming to Chinese color spectrum sample booklet A26003-94 standard), visual function test instrument, color blindness check manual, and illumination photometer. Two sets of experimental color cards are exactly the same, including 40 kinds of hue/color

lump, and hue selection is based on definition of tone, brightness, and chroma in GB/T 15608/1995 “China color system.” See Fig. 32.1 tone ring for these 40 kinds of hues, taking 5 colors (red (R), yellow (Y), green (G), blue (B), and purple (P)), as principal color. Those 5 colors between two adjacent main colors are intermedium colors, including yellow and red (YR); green and yellow (GY); blue and green (BG); purple and blue (PB); and red and purple (RP). The principal and intermedium colors are composing 10 basic colors, while each basic color occupies one section of the ten points of the tone ring. In a similar way, divide the gamut between 10 kinds of basic and adjacent colors into four halves, which are called the auxiliary colors. The grade difference between two adjacent tones is defined as one grade, and if there is one grade between the tone location judged by subjects and the actual color position, it is called as one error degree. Error degree reflects the displacement of tone identified by subjects deviated from the correct tone, and error ratio reflects error times of the subjects to the tone identification.

### ***32.2.2 Experimental Condition***

The experimental site is the darkroom for “lighting and display ergonomics testing analysis laboratory,” no external stray light. Color work surface’s vertical illuminance level is controlled at about 500 lx; light irradiates uniformly in surface of the color card operation and does not produce glare. In the experiment, the subjects observe color cards directly through both eyes, and observation perspectives coincide with normal line of operation planes of the color cards.

### ***32.2.3 Subjects***

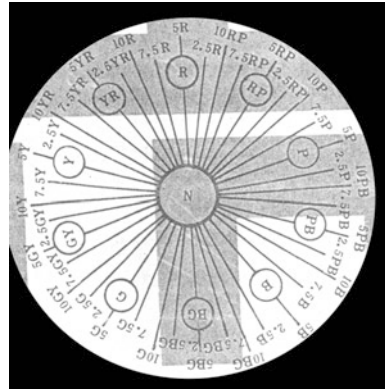
There are 20 subjects, including 10 men and 10 women, who are between 20 and 40 years. Make two-way check through the visual function test instrument and the color blindness check book on color vision function, with good color sensation and sensitive to the color.

### ***32.2.4 Experimental Project***

#### **32.2.4.1 Effect of Light Source Color Index on the Subjects of Color Rapid Identification Ability**

Subjects first observed one color block X of the experimental color card 1 under the contract light source and then observed all color blocks of the experimental color card 2 under the light source to be tested, and color block Y is chosen from them,

**Fig. 32.1** Structure of color tone circle



which has same tone with color block X, namely finish fast identification of one tone block; took rest for 1–2 min; and completed fast identifications for all 40 tone blocks and then took rest for 15 min. Complete fast identification of 40 color blocks in turn was performed, when  $R_a$  of the light source to be tested were 80, 70, and 60, respectively. The tasks below are called 90–80 identification, 90–70 identification, and 90–60 identification for short. Each subject had been tested for 3 times.

#### 32.2.4.2 Influence of Light Source Color Rendering Index on Subjects' Color Comparison Ability

Subjects made one-to-one comparison and matching between each color block in the experimental color cards 1 and 2 and did the same comparison and matching experiments in the light source to be detected ( $R_a$  were 80, 70, and 60, respectively). Color matching task hereinafter is referred to as the 90, 80, 70, and 60 comparison. Each subject had been tested for 3 times.

### 32.3 Results and Discussion

#### 32.3.1 Color Rendering Index of Light Source Influence on Subjects' Color Comparison Ability

From Table 32.1, when  $R_a$  of the light sources are 90, 80, and 70, comparison right ratio of three comparison tasks was similar and in the range of 94–95 %, and the comparison right ratio corresponding to each tone is higher, and the difference is not obvious; when  $R_a$  of the light source is 60, its comparison right ratio is slightly lower (91 %). In general,  $R_a$  of the light source has no obvious influence on the right ratio of color matching operation. This is because light source has

**Table 32.1** Relation between CRI and right ratio and error degree in color comparison task

Task	Right ratio (%)	Error times	Total of error degree
Color comparison under Ra of 90	95	2	4
Color comparison under Ra of 80	94	2.4	4.5
Color comparison under Ra of 70	94	2.4	4.7
Color comparison under Ra of 60	91	3.6	6.9

different render index, but the two experimental color cards are in the same light source; color deviation produced is consistent objectively, leading to consistent subjective deviation of human eyes on the tone.

Moreover, with the decline in Ra of the light source, error degree appeared in the comparison task showed increasing trends, especially error frequency and error grade of light source under Ra of 60 were significantly higher than those in other states; this suggests that it might be related to some tone. When light source Ra is 60, some tons' subjective bias will increase. Therefore, in order to improve the accuracy of color matching and reduce the deviation as far as possible, it should choose light source with Ra higher than 70.

### ***32.3.2 Influence of Color Rendering Index of Light Source on the Capacity for Color Rapid Identification***

Table 32.2 shows right ratio, error times, and sum of error grade of the subjects to fast color identification tasks. It can be found when color card 1 is in the comparison light source under Ra of 90, and color card 2 is in the light source to be tested under Ra of 80, 70, and 60, average right ratio of color identification of subjects all declined more than a half. It denotes that after people observe objects' color in the contrast light source, if they observe objects with same color in the light source to be tested again, they will quickly feel color difference, and it is easy to judge different tones for same tones.

Analyzing its causes, first, the light source with different CRIes has more obvious impacts on capacity for rapid color identification, which is consistent with the excellent grade results (Ra being 75–100) of color rendering capacity, normally got by analyzing the identification capacity of color adaptation. Therefore, in order to improve the correct rate for color identification and reduce displacement of identification deviation, light source Ra should be higher than 70; secondly, it is discovered by further analysis on the experimental data that most the color tones with identification error are in the positions of auxiliary colors of the tone ring. It prompts us division of 40 tones may increase the difficulties of short-term memory to color, causing obvious reduction in fast memory capacity of color based on short-term color memory. Therefore, in the color memory and identification task, it should avoid the existence of the auxiliary color between two

**Table 32.2** Relation between CRI and right ratio and error degree in color identification task

Task	Right ratio (%)	Error times	Total of error degree
Color identification under Ra of 90 and 80	45	22	51.3
Color identification under Ra of 90 and 70	47	21.2	50.4
Color identification under Ra of 90 and 60	38	24.8	62.7

adjacent basic tones at the same time, namely avoiding color memory and identification operations with slight difference.

### 32.3.3 Color Comparison Right Ratio and Tone of the Subjects

Table 32.3 lists the color comparison correct rate corresponding to different tones in the color comparison operation. View from light source under Ra of 90, 80, 70, and 60, respectively, correct rate corresponding to YR, GY, B, and PB, four kinds of tones, presents the concentrated and consistent tendency; they are all above 95 %; correct rates corresponding to Y, P, and RP three kinds of tone are between 87 and 100 %, while those corresponding to R, G, and BG are between 83 and 93 %. It is analyzed that the light source’s spectrum energy distribution is the main factor to decide the light source rendering property. The experiment selects three primary color fluorescent lamps, which have the continuous spectrum and the banded spectrum; color rendering property of the continuous spectrum is better; it is that light source has better rendering property to the partial tone, but poor to the rendering property of certain color tones. Therefore, when selecting the light source, special CRIs should be considered according to the concrete task demands.

**Table 32.3** Color tone and right ratio of color identification under different Ra (%)

Task	Color tone									
	R	YR	Y	GY	G	BG	B	PB	P	RP
Color comparison under Ra of 90	90	100	98	100	91	84	98	96	94	95
Color comparison under Ra of 80	91	98	95	98	83	89	97	94	98	100
Color comparison under Ra of 70	91	96	92	100	90	93	97	93	96	91
Color comparison under Ra of 60	83	95	87	100	83	89	97	95	91	90

## 32.4 Conclusion

This paper studied the influence of light source with different CRI on the color comparison capability and color fast identification ability. Results indicate that, when light source Ra is greater than 70, it has inconspicuous influence on the color comparison and fast identification capacity, so the light source with CRI higher than 70 should be chosen. To different color identification task, both general and special CRIs of light source should be considered; thirdly, when arranging the color memory and identification operations, it should avoid adopting the auxiliary color between 2 basic tones; difference between tones should be improved.

## References

1. Wenting Cheng (2011) The method of color quality evaluation of white light LED. *China Illumin Eng J* 22(3):38–41
2. Zhijie Li (2008) Color-rendering index of evaluation standard of print light source. *Qual Stand* 6:38–42
3. Yicheng Liu (2000) Color-rendering properties and color-rendering index of light source. *J Electron Devices* 23(1):38–41
4. Haisong X (2005) Color information engineering. Zhejiang University Press, 43–47
5. Guie Cheng (2003) Rational election of light sources in green lighting engineering. *Shanxi Archit* 18:94–95

# Chapter 33

## Research on the Influence of Traffic Conditions on the Psychology of Indirect Vision Drivers Based on EEG Analysis

Zhiying Qiu, Zhicheng Wu, Jingjie Wu, Jie Bao and Jia Zhou

**Abstract** Numbers of studies have shown that electroencephalogram (EEG) signals can objectively reflect the physiological and mental state of a human being. In order to explore the influence of traffic conditions on the indirect vision drivers' EEG, we asked the volunteer drivers to drive a car equipped with indirect vision driving system around the test loop for 3 times and collected the drivers' EEG signals in real time. Meanwhile, a driving video recorder equipped on the windshield was used to record the traffic conditions of every lap. Contrasting the videos of traffic conditions, the changes of EEGs were analyzed. The result shows that the average attentions of indirect vision the driver driving on the curve lanes and when the vehicle starts to move or stops to run are higher than driving on the straight section, and the transient attention of the indirect vision driver appears peaks when meeting another vehicle, bike, and pedestrian. It means that complex traffic conditions and operant tasks could make indirect vision driver's psychology burden heavier.

**Keywords** Experiment · Indirect vision driving · Different traffic conditions · EEG · Changes

### 33.1 Introduction

Special vehicles have to be driven by indirect vision driving in some dangerous environment. Since the visual environment displayed inside the car is quite different compared with the direct vision driving visual environment, drivers must have maladjustment more or less and they need a gradual process of adaptation.

---

Z. Qiu · Z. Wu (✉) · J. Wu · J. Bao · J. Zhou  
School of Mechanical Engineering, Beijing Institute of Technology,  
Beijing 100081, China  
e-mail: wu\_zhicheng@bit.edu.cn



What's more, the level of adaptation, the length of adaptation period also varies from person to person. So it is extremely important to research the man-machine-environment system composed by drivers and the indirect vision driving system. All these factors have very important practical significance for providing fundamental basis for the future feasibility analysis and a method of theoretical optimization [1].

The process of driving is a process of exchanging information and control. The conditions of car and environment are the sound basis information for drivers to decide driving behaviors. The drivers' sense organs accept information from outside. After the process of sensory store, perception of decoding, memory and decision making, implement and feedback, the drivers achieve the control of the vehicle. In this stage, drivers' nervous systems are high-strung. Thus, it can be seen, the drivers' psychological burden is very heavy. However, psychological feelings are abstract, so we need an index to express their feelings [2].

Electroencephalogram (EEG) is an important reaction of brain activity and drivers' attention and meditation can be reflected by the brain atlas. The studies of the drivers' EEG at home and abroad are as follows: John Richardson used physiological signals such as eye movement and EEG to research the regular pattern of driving fatigue [3]; Japan already had reports on using EEG to research the drivers' fatigue [4]; Chung from South Korea had used EEG to discuss the influence on the drivers when in different road conditions (such as straightway and curved section in the same length). He also discuss the drivers' nervous conditions when they drive on different location of the entrance of the ramp [5]; In 1998, Goebel Matthias and Springer Johannes from German measured the short commute bus driver's EEG and eye movement data. They made a conclusion that after redesigning the chamber, the driver's work load is significantly less than before [6]; Wu Zhicheng in our country from Beijing Institute of Technology summarized the development situation of indirect vision driving technology [7]; Wang binghao from Zhejiang University used dynamic electroencephalograph named KT98-2000A to record the dynamic EEG of the drivers who are physically and psychologically healthy in order to research their drive fatigue; Lin yingzi from China Agricultural University had analyzed and described the driver's psychology states and put forward a mental model of qualified driver. Then, he put forward several indexes of the physical and mental reaction test and carried out the test related. Finally, he got the changing rule of the physical and psychological conditions when different drivers run in different speed and different routes [8].

EEG signals can objectively reflect the physiological and mental state [9]. Since there are variety of EEG, waveform change sensitivity and the anti-interference ability is poor, so the different road and driving conditions can be used as stimulating source to induce EEG's significant change.

**Fig. 33.1** Assembling position of flat displays in crew cab



## 33.2 Experimental Methods

### 33.2.1 Apparatus

1. An off-road vehicle was used as the experimental platform.
2. The indirect vision driving system equipped on the test vehicle consisted of three High Definition (HD) cameras, three 16:9 wide screen liquid-crystal display (LCD) and the devices for video transmission. For acquiring more visible area, a 23-inch-wide screen light-emitting diode (LED) backlit LCD with resolution of  $1,920 \times 1,080$  pixels has been used as main screen. Two 11.6-inch LED backlit LCDs with resolution of  $1,366 \times 768$  pixels are turned  $90^\circ$  individually and seamlessly fixed on both side of main display as assistant screens, as shown in Fig. 33.1.

The left and right assistant cameras were individually mounted on the frameworks of side rearview mirrors. For mounting main camera, based on the suggestion from majority voluntary drivers, the middle position on the center of windshield bottom beam was finally selected, as shown in Fig. 33.2.

3. A travelled recorder was used to record the whole process of every lap. It can record different traffic conditions at all mark points and emergency situations in the process of driving. The video will be stored in a computer with the format of mp4 which will be analyzed and processed later.
4. A pair of headset which is produced by NeuroSky was used to measure brainwave signals. The headset can turn a computer into a brain activity monitor for providing an algorithm to calculate the attention and meditation of drivers according to the detected signal. So it can be successfully used for brain wave test.

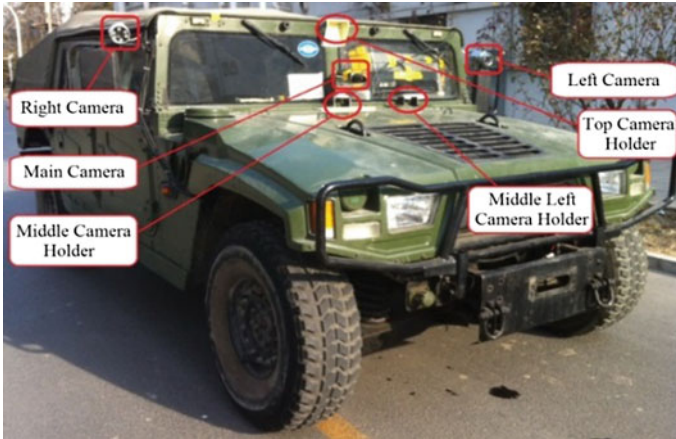
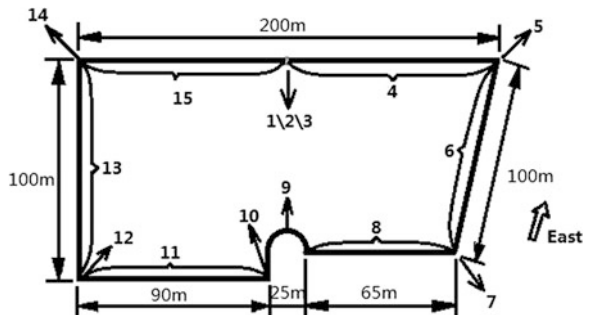


Fig. 33.2 Assembling position of cameras on the wheeled test vehicle

Fig. 33.3 Schematic diagram of test course loop



### 33.2.2 Test Course Loop

The voluntary drivers have driven the test vehicle on a test course loop which total length is nearly 600 m delineated from our campus road including six straight sections, five curves, and one roundabout lane. The schematic diagram of test course loop is shown in Fig. 33.3.

### 33.2.3 Participants and Process

Six students aged from 22 to 30 participated in the experiment. These six people are physically and mentally healthy and have similar driving experience. These factors are very important to minimize differences between subjects variability. Before the experiment, it should make sure that the subjects have adequate sleep

and normal state of mind. They are also forbidden to eat any alcoholic food or drink any caffeine-containing beverages. What's more, they must not eat anything or do any intense exercise 1 h before the experiment. In addition, experimenters must keep quiet during the process of the experiment.

The time required for one circle is divided into 15 marked points artificially. The marked points numbered 1–15 represented starting stage, no. 1 straight section, turn 1, no. 2 straight section, turn 2, no. 3 straight section, roundabout lane, turn 3, no. 4 straight section, turn 4, no. 5 straight section, turn 5, no. 6 straight section and parking stage. Since each driver's speed is not the same, so we need to find the periods of time corresponding to every marked point recording to the time in the video recorded by the travelled recorder and the EEG's time point. In this paper, the averages of attention and meditation were counted with each driver's driving time. Then, we make a line chart. The average indexes of each driver's attention or meditation have been obtained as the ordinate axis and the 15 marked points are used as abscissa. (Since every driver had do the experiment for three times, we choose only one set of experimental results which had strong regularity).

### 33.3 Analysis and Discussion

#### 33.3.1 *Driving in Different Traffic Conditions*

From the shapes of the line chart we can see, the drivers' attention change obviously in different road conditions. Compared with the index at departure stage, the drivers' attention increases significantly when they are at marked points 4, 6, 8, 9, 11, and 13. It means the drivers' spirit is more concentrated and they bear heavier psychological burden in these conditions. What's more, it illustrates the drivers' driving adaptability is poor under the conditions of curves and roundabout lanes. In contrast, at marked points 3, 5, 7, 10, 12, and 14, drivers' attention decline indicated that their stress-level drop and burdened with less emotional baggage. So, the drivers' driving adaptability is good at straight sections. There are two peaks at marked point 2 and 15. It means complex operations activities can bring heavier psychological burden to drivers (Fig. 33.4).

#### 33.3.2 *Meeting Other Vehicle, Bike, and Pedestrian*

To study the changes of drivers' brain wave under special conditions such as meeting other vehicle, meeting bike, and pedestrian, we choose B.J.'s EEG to make line charts which is the most representative (Fig. 33.5).

In the Fig. 33.6a, the driver entered the straight at 10:11:27. The attention index was 43 when the driver had just seen the car came from the other side. The

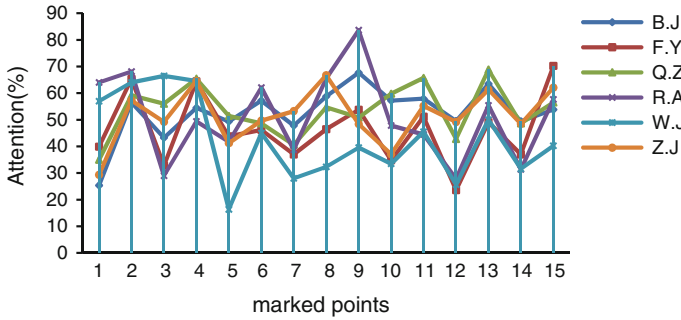
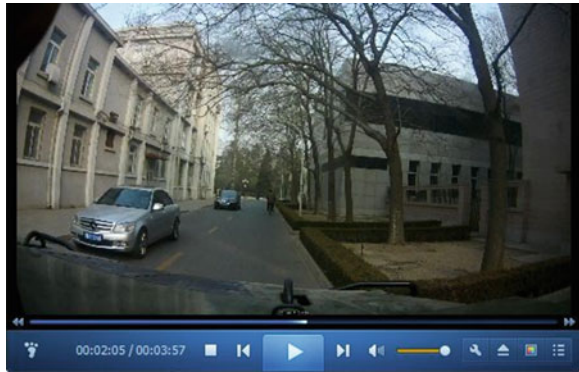


Fig. 33.4 The experiment results of driver’s attention

Fig. 33.5 Meeting other vehicle



attention index peaked to 83 at 10:11:33 when two cars began to pass each other. At 10:11:40, the driver had passed the car with the attention drop to 43. During this period, the driver’s attention increased gradually before reached to the peak and then declined to 43 at last. The range of variation of attention index was 40. Figure 33.6b shows that the driver’s meditation was 48 at 10:11:27 which was at a relatively high level. Then, it drop to 26 at 10:11:32 when the driver almost began to meet another vehicle (Its a second before two cars began to pass each other). The total variation is 22. The meditation drops to 14 in the final of the meeting period).

After analysis, it can be found that the driver’s attention index increases gradually and then decreases which has distinct regularity. At the start of meeting, the driver’s meditation declines, but it does not rise after the driver has passed the car. So there is no obvious regularity in meditation (Fig. 33.7).

In Fig. 33.8a, the driver’s attention index was 43 at first. When the vehicle met bikes at 10:12:15, the attention immediately increased to 54. Then, it peaked to 67 at 10:12:17 and declined later. The attention dropped to 64 at 10:12:20 when the vehicle had passed bikes totally. But it peaked again to 81 at 10:12:23 after the vehicle met pedestrians at 10:12:21 then declined gradually to 27 when the vehicle

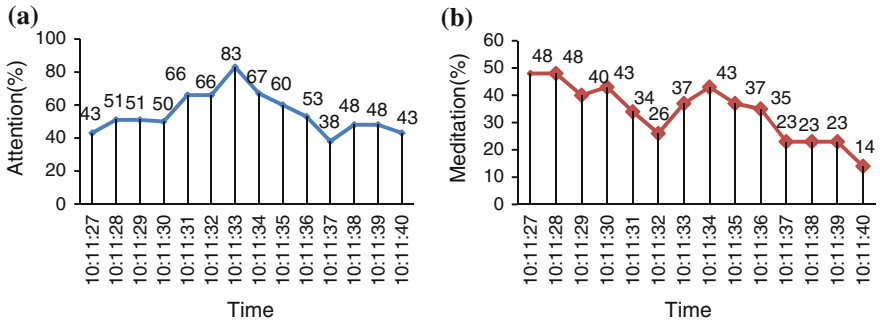


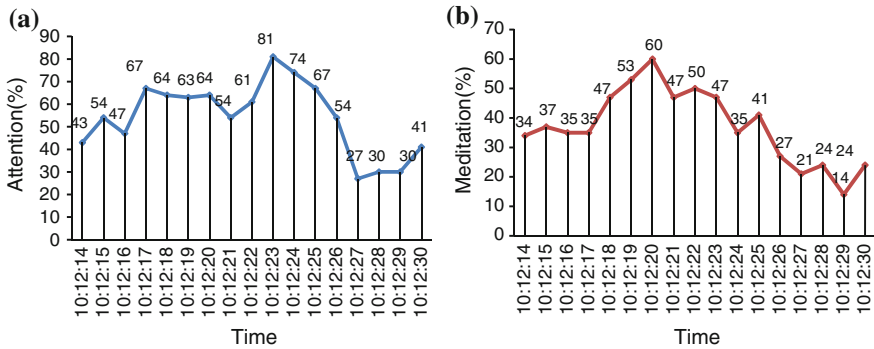
Fig. 33.6 The experiment results of driver’s attention and meditation when meeting other vehicle. a is index of Attention b is index of meditation



Fig. 33.7 Meeting bike and pedestrian

had totally passed the pedestrians at 10:12:26. When the vehicle was running on no. 5 straightway, although the number increased slightly, but it remained at a low level. Figure 33.8b shows that the meditation index increased to 37 at 10:12:15 when the driver started to pass bikes and then went up to 60 at 10:12:20. During this period, the range of variation is 23. At 10:12:21, the driver’s meditation index decreased 13 for coming across pedestrians. At 10:12:26, it was 27 when the driver had passed pedestrians. Afterward, the driver’s meditation kept at a relatively low level and did not rise up when the driver kept on driving on the no. 5 straightway.

Overall, drivers’ attention will increase significantly when meeting bikes or pedestrians which means their spirit is highly concentrated at that moment and they have heavier psychological burden. In contrast, their meditation will decrease. After they have passed them, the attention will decrease. But the meditation index would not increase after that.



**Fig. 33.8** The experiment results of driver's attention when meeting bike and pedestrian. **a** Is index of attention, **b** is index of meditation

### 33.4 Conclusions

1. The average attentions of indirect vision driver driving on the curve lanes and roundabout lanes are higher than driving on the straight section. So the change of traffic conditions can cause significant difference in drivers' attention.
2. When the vehicle starts to move or stops to run the driver's average attentions rose significantly which indicates operant tasks could make indirect vision driver's psychology burden heavier.
3. The transient attention of the indirect vision driver appears peaks when meeting other vehicle, bike, and pedestrian. It means that complex operant activities lead to the heavy psychological burden on the drivers directly. What's more, during the period of meeting another vehicle, the driver's attention increases gradually before reached to the peak and declined after. So in this period, the driver's attention has obvious regularity.
4. Compared with the driver's attention which has obvious regularity, the meditation decreases at the time of meeting other vehicle, bike, and pedestrian, but it would not increase after the driver has passed by. So it has no regularity as a whole.

### References

1. Liu C et al. (2013) Detecting driving fatigue of indirect vision driving based on electroencephalogram. *Advanced information and computer technology in engineering and manufacturing, environmental engineering*. *Advanced Materials Research*, v765-767, Xiamen, Fujian, China, pp 2046–2050
2. Han GAO (2008) Experimental study on the driver's physiological characteristics under simulated driving conditions. Harbin Institute of Technology, Harbin
3. Richardson J (1994) Driver fatigue: an experiment investigation. In: *Proceedings of the 27th ISATA*, Aachen, Germany, pp 329–343

4. Akutsu E (1995) Summary of driver's drowsiness sensing technology. *Automobile Technol (Japan)*, 49(7). Tokyo, Japan
5. Chang M, Kim J, Kang K, Yun J (2001) Evaluation of driver's psychophysiological load at freeway merging Area. TRB, ID Number: 01-0535
6. Elizarova VV, Shardakova EF, Yampol'skaya EG (1994) Electromyography evaluating neuromuscular fatigue caused by working postures of loader drivers. *Gig Tr Prof Zabol* 1994:7-10
7. Wu ZC, Chen S, Yang L, Yuzhuang Z (2012) Summary of development situation of indirect vision driving technology. Chinese Society of Automotive Engineers SUVs Technology Branch, October 1, 2012, Wuhan, China
8. Lin Y, Yu Q (1998) The driver's physiological and psychological analysis and testing in the process of vehicle steering. *Automot Eng* 2:71-76
9. Yang R (2007) EEG signal acquiring and processing & analysis. Guangxi Normal University. Guilin, Guangxi, China



# Chapter 34

## Contrast Research on Ergonomics of Vehicle Drivers in Indirect and Direct Vision Environment

Jia Zhou, Zhicheng Wu, Jingjie Wu, Zhiying Qiu and Jie Bao

**Abstract** Flat displays will be used to provide a better view for drivers in some future special vehicles, but the drivers have to observe the outside environment only by the displays in cab. As there is a great difference between the two-dimensional visual environment provided by onbroad displays and the visual environment for the drivers who drive normal vehicle by direct vision, the psychological and physiological responses of indirect vision drivers are quite different from direct vision drivers. An indirect vision driving system was equipped on a large sport-utility vehicle, and the contrast experiment between indirect vision driving and direct vision driving was carried out. Psychological and physiological index of drivers, such as EEG, pulse, blood oxygen saturation, and completing task time, has been collected and processed using mathematical statistical methods. The comparative analysis result shows that the physiological load of drivers in indirect vision driving mode and direct vision driving mode is nearly the same, but the psychological load in indirect vision driving mode is higher than that in direct vision driving mode; thus, the total workload of indirect vision driver is higher.

**Keywords** Contrast experiment · Indirect vision driving · Direct vision driving · Psychological and physiological index

### 34.1 Introduction

The indirect field is what the driver views indirectly by use of imaging devices such as the inside mirrors, outside mirrors, or display screens showing camera views or locations of objects detected by other sensors [1]. The new indirect vision driving system is equipped with one or more HD cameras and panel displays for

---

J. Zhou · Z. Wu (✉) · J. Wu · Z. Qiu · J. Bao  
School of Mechanical Engineering, Beijing Institute of Technology,  
Beijing 100081, China  
e-mail: wu\_zhicheng@bit.edu.cn

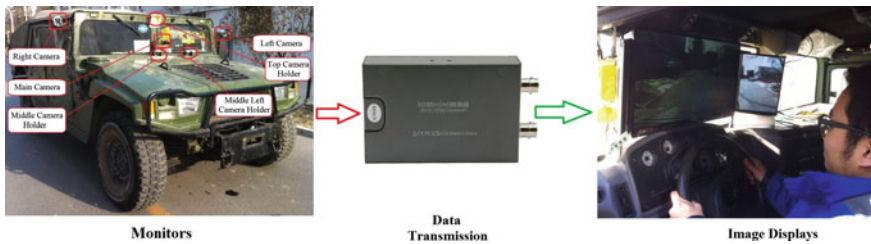
displaying the video images shot by the cameras. The new indirect vision driving system can be used to replace the traditional periscopes and narrow windows on some special vehicles and provide a better driving vision for drivers. In 1990s, the US Army started to pay attention to a research on driving via indirect vision driving system [2]. Computing Devices Canada Ltd has built and developed a vehicle platform equipped with flat-panel display for the US military and conducted the experiments in 2000 [3].

In recent years, the research emphasis has changed from the indirect vision driving system hardware to the system of the Man–Machine–Environment which concludes driver, the indirect vision driving system, and traffic environment. In 2002, Dutch scientist J. Van Erp started to pay attention to the disease problem by using head-mounted camera system. The US Army Research Laboratory, M.D. & Ph.D. C. C. Smyth made a research on task performance and workload of an indirect vision driving with fixed flat-panel displays [4]. The domestic research on vehicle indirect vision driving system is still in its infancy. Wu Zhicheng from Beijing Institute of Technology summarized the development situation of indirect vision driving technology [5]. In 2013, Bao Jie made a research on the effects of image parameters on driving fatigue and task performance of the drivers in the indirect vision driving system [6]. The two-dimensional visual environment provided by the screen of indirect driving vision system is quite different from the direct driving vision environment for normal drivers, so it is necessary to carry on a contrast experiment between the indirect vision and direct vision driving systems and compare the drivers' performance in the direct and indirect vision driving modes.

## 34.2 Research Content

### 34.2.1 *Indirect Vision Driving System*

The new indirect vision driving system includes three parts: monitors, data transmission, and image displays. The monitor consists of three high-definition (HD) cameras and holders, among which the main cameras are Tongwei HD-SDI 1080 P. Deputy cameras are ordinary analog cameras. The image display includes three 16:9 wide screens with liquid crystal display (LCD) and the devices for video transmission. A 23-inc. wide-screen light-emitting diode (LED) backlit LCD with resolution of  $1,920 \times 1,080$  pixels has been used as main screen for a more visible area. To obtain a better driving vision while turning, two 11.6-inc. LED backlit LCDs with resolution of  $1,366 \times 768$  pixels are turned  $90^\circ$  individually and seamlessly fixed on both sides of main display as assistant screens as shown in Fig. 34.1. Because the output is SDI which is not adopted by screens, the high-speed converter from SDI to HDMI is chosen to ensure the quality of image transmission and transmission speed.



**Fig. 34.1** Indirect vision driving system components. The device includes three HD cameras on the *left side*, the transmission line and the converter on the *middle*, and display screens in the cab on the *right side* of figure

### 34.2.2 Experimental Data Collection

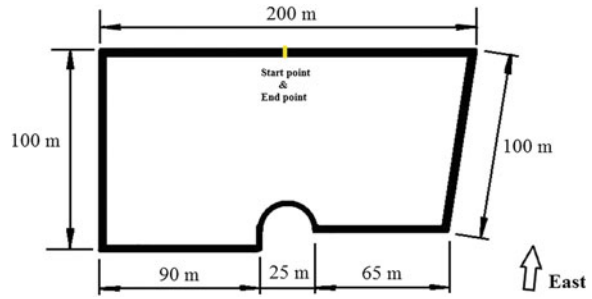
Ten voluntary drivers aged 20–45 years have been recruited for the outdoor experiment. All of them are healthy and have driving licenses. They are from Beijing Institute of Technology. Before the experiment, drivers maintain adequate sleep and rest to ensure they are energetic and sober. The outdoor experiment was carried out in weekend for avoiding interruptions of pedestrians and vehicles. The voluntary drivers had to drive the test vehicle on a test course loop whose total length was nearly 600 m delineated from our campus road. The schematic diagram of test course loop is shown in Fig. 34.2. Every driver was required to try their best to drive in direct and indirect vision environments according to the regulation route for five laps, under the premise of ensuring safety. Experiment time was from 10:30a.m. to 4:00p.m., and the weather was fine. In the start and end point, completion time, EEG (electroencephalogram), oxygen saturation, and pulse rate were recorded.

Second is the unit for the time which is spent every lap. It is a comprehensive index and is used to measure the driver’s degree of fitness and proficiency and difficulty of the driving task. It is also a reference index for EEG, oxygen saturation, and pulse rate.

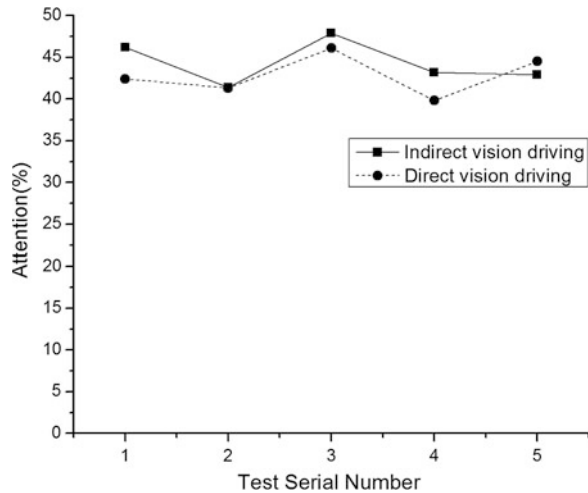
The MindWave headset, a safe EEG measure device developed by NeuroSky, is used to measure brain wave signals. Brain is a complex world, and people will have different electrical response in different conditions. In order to study conveniently, EEG signal is roughly divided into the following four basic waveforms according to the frequency and amplitude: alpha, beta, theta, and sigma waves. In these basic waveforms, beta waves are directly related to degrees of excitement when people are stimulated by environment, but it is difficult to analyze because the brain wave is complex [7]. So the “attention” parameter provided by MindWave instrument is used to analyze the brain electrical signal. Attention reflects the users’ current attention degree.

In the experiment, a wrist pulse oximeter whose type is Heal Force Prince-100G is used to measure oxygen saturation and pulse rate. Its sampling cycle is 2 s. Oxygen saturation is a percentage that indicates the saturation of the combination

**Fig. 34.2** Schematic diagram of test course loop. Its total length is nearly 600 m



**Fig. 34.3** Drivers' attention average in direct vision and indirect vision driving modes

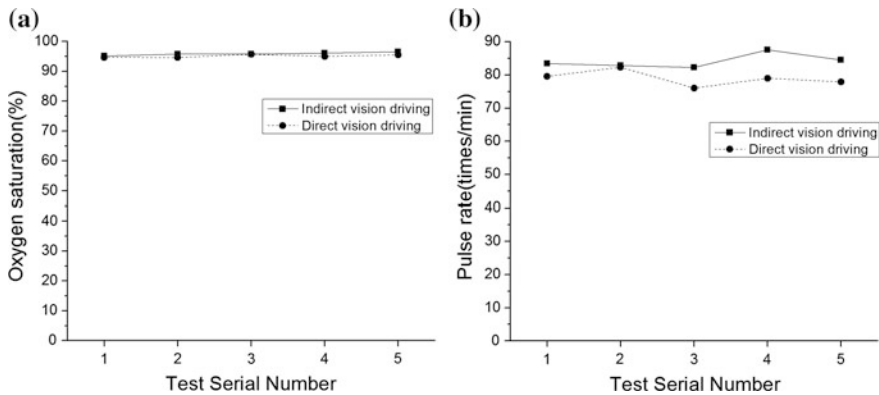


of oxygen and hemoglobin, which will decline when mental workload increases because the human bodies need certain amount of oxygen supply for extra workload [8]. Pulse rate is generally consistent with heart rate. Heart rate is mostly widely used in ergonomics research, which shows typical rise when the mental workload exceeds the normal level [9].

### 34.3 Analysis and Discussion

In order to study the difference between the direct vision driving and indirect vision driving modes, ten drivers' psychological and physiological parameters have been calculated and contrasted.

Because the EEG signal is nonlinear and has no obvious change law, it is very difficult to analyze EEG signal directly. Volunteers' five experimental conditions are the same, so their attention can be averaged, as shown in Fig. 34.3.

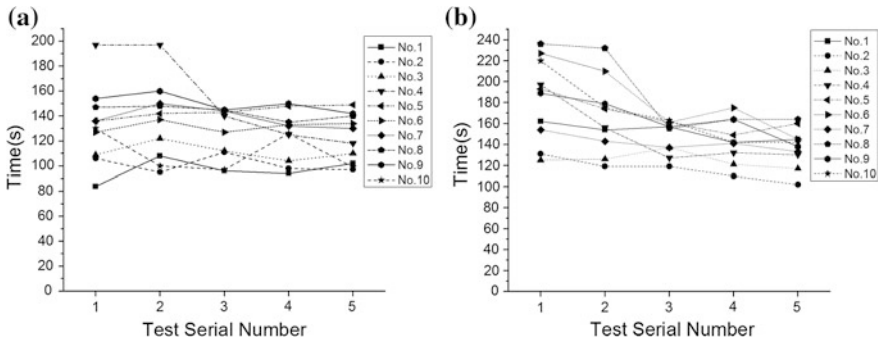


**Fig. 34.4** Oxygen saturation average and pulse rate average in direct vision and indirect vision driving modes. **a** is oxygen saturation average, and **b** is pulse rate average

Figure 34.3 shows that drivers’ attention average trend is relatively stable in direct vision and indirect vision driving modes, and their average value is very close. It means that both in direct vision mode and in indirect vision driving mode, the drivers are very focused and there is little difference with their attention; that is, the level of psychological load for the vehicle drivers in indirect vision driving mode is similar to that in direct vision driving mode. Compared with direct vision driving system, the indirect vision driving system does not increase drivers’ psychological load.

In Fig. 34.4a, the trend of oxygen saturation average in the direct vision and indirect vision driving modes is nearly the same. Figure 34.4b shows that with driving times increasing, pulse rate in indirect vision driving mode increases, but pulse rate in direct vision driving mode remains almost unchanged. Comparing the Fig. 34.4a and b, pulse rate average in indirect vision driving mode is higher than that in direct vision driving mode, but the oxygen saturation is nearly the same. It means that drivers’ oxygen consumption in indirect vision driving mode is higher than that in direct vision driving mode, and with driving times increasing, oxygen consumption in indirect vision driving increases. Compared with direct vision driving system, the direct vision driving system increases drivers’ psychological load.

Figure 34.5 shows the time which 10 volunteers have used to finish the each task in direct vision and indirect vision driving. Everyone carries out experiments for five laps. It can be seen that in the direct vision driving mode, drivers are able to adapt to driving conditions quickly and the time for each lap is stable. While in the indirect vision driving mode, because drivers are not familiar with the system, the driving time is longer than that in the direct vision driving, especially at the beginning of the experiment. With driving times increasing, drivers gradually adapt to indirect vision driving system. After three laps, driving time has become stabilized.



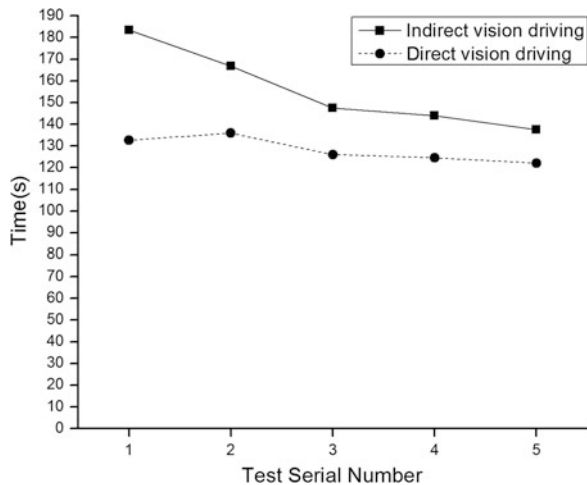
**Fig. 34.5** Task completion time for 10 drivers in direct vision driving mode and in indirect vision driving mode. **a** is in direct vision driving mode, and **b** is in indirect vision driving mode

To compare the driving time more intuitively and clearly, the total time for 10 volunteers in each lap is averaged, respectively, in direct vision and indirect vision driving modes, as shown in Fig. 34.6.

Figure 34.6 shows that the total driving time average in direct vision driving mode is stable, and the time is about 130 s. The driving time curve in indirect vision driving mode is monotonically decreasing. The slope of the first two laps is higher and decreases linearly. It starts to remain unchanged in the third laps. Comparing with the average driving time in direct vision and indirect vision driving modes, the time in indirect vision driving is longer. But with the driving times increasing the time in indirect vision driving becomes shorter, and its difference on the direct vision driving time gradually reduces.

Main reason is that road condition information in indirect vision driving mode is provided by the image, which is quite different from visual field in direct vision

**Fig. 34.6** The task completion time average in direct vision and indirect vision driving mode



driving mode through the window. This will produce a certain pressure to the driver's psychology and then affect the driver's driving speed in the direct driving environment. But with the driving times increasing, the volunteers are more familiar to indirect vision driving system. Their adaptability to the system has been enhanced, so the driving time reduces.

The contrast analysis result shows that the physiological load for drivers in indirect vision driving mode and direct vision driving mode is nearly the same, but the psychological load in indirect vision driving mode is higher than that in direct vision driving mode. Considering the task completion time, the time in the indirect vision driving mode reduces significantly, but in the direct vision driving mode, it reduces slowly with the driving time increasing.

### 34.4 Conclusions

1. The workload for the vehicle drivers in indirect vision mode is higher than that in direct vision mode, but the difference of total workload between in indirect and direct vision environments decreases with the driving time increasing.
2. With the driving time increasing, the workload for the vehicle drivers in indirect vision mode decreases. It means that the drivers' maladjustment in indirect vision mode decreases with the increase of driving experience.
3. The task completion time in the indirect vision driving mode reduces with the driving time increasing. It means that it can improve drivers' maladjustment for indirect vision environment by training.

### References

1. Bhise VD (2011) Ergonomics in the automotive design process. CRC Press, Boca Raton, pp 107–108
2. O'Kane, BL (1996) Driving with indirect viewing sensors: understanding the visual perception issues. Enhanced and synthetic vision, 8–10 April 1996, Orlando, FL, USA SPIE-Int. Soc Opt Eng, USA
3. Downs G, Roller G, Brendle BE, Tierney T (2000) Military application of flat panel displays in the vetrronics technology testbed prototype vehicle. In: Proceedings of the SPIE—the international society for optical engineering, vol 4022, 75–84. Cockpit displays VII: displays for defense applications, 25–28 Apr 2000, Orlando, FL, USA
4. Smyth CC (2002) Modeling indirect vision driving with fixed flat panel displays: task performance and mental workload. Final report, NTIS, 5285 Port Royal Road, Springfield, VA, 22161, USA
5. Wu ZC, Chen S et al (2012) Summary of development situation of indirect vision driving technology. Chinese society of automotive engineers SUVs technology branch, Oct 1, 2012, Wuhan, China
6. Bao J et al (2013) The impact of image parameters of indirect viewing systems on driver fatigue and task performance . Advanced information and computer technology in engineering

- and manufacturing, environmental engineering. *Advanced Materials Research*, v 765–767, Xiamen, Fujian, China, pp 2046-2050
7. Xiao-dong Xu (2009) Experimental research on driving fatigue based on EEG analyzing. Tongji University, Shang Hai
  8. Sassaroli A et al (2008) Discrimination of mental workload levels in human subjects with functional near-infrared spectroscopy. *J Innov Opt Health Sci* 1(2):227–237
  9. Roscoe A. H.(1992). Assessing pilot workload: Why measure heart rate, HRV, and respiration In: *Biological Psychology* v. 34, Issues 2–3, November 1992, p. 259–288



# Chapter 35

## Research on Environmental Suitability of Operation Staffs at Frigid Plateau Region

He Wei, Honglei Li, Zhibing Pang, Cheng Jin, Yuankang Sun and Xingbin Zhu

**Abstract** This paper summarizes the effects on operation staffs casted by the frigid plateau environment through analysis of the characteristics of geographical environment and climatic characteristics of this kind. In order to explore ways to improve job performance, the author begins with the operation staffs' physical ability, intelligence, and skills, takes the suitability to environment as a breakthrough point, and proposes effective training methods to improve operation staffs' environmental suitability from four aspects of psychological and physical quality, professional skills, and logistics support. Therefore, it is a must to launch various adaptive trainings with the psychological and behavioral training, hypobaric hypoxia training, professional skills training, and equipment and logistics support drill as highlights.

**Keywords** Frigid plateau region · Operation staffs · Environmental suitability

### 35.1 Introduction

Because of the high mountains and deep valleys at the Tibetan frigid plateau region, environment conditions such as cold, hypoxia, large diurnal amplitude, and strong ultraviolet radiation can be found there, seriously affecting the improvement of job performance. More researches on how to improve operation staffs' environmental suitability under frigid plateau environment have a major significance for the purpose of mastering the characteristics of this area to improve operation staffs' environmental suitability.

---

H. Wei (✉) · H. Li · Z. Pang · C. Jin · Y. Sun · X. Zhu  
Air Defence Forces Academy, Zhengzhou 450052, China  
e-mail: fkb\_mmes@163.com

H. Wei  
Unit71823 of PLA, Luohe, China

## **35.2 Environmental Characteristics of Frigid Plateau Region**

Environments kinds of Tibetan frigid plateau region can be divided from geographical and climatic perspective. The following will analyze these two from the view of their physiological and psychological impacts on human.

### ***35.2.1 Characteristics of Geographical Environment***

As being included in the high and cold mountainous, the Tibetan frigid plateau region is such a typical region where the terrain is featured with towering peaks, steep mountains, and basin alternating with ridges and peaks. It covers a vast area; areas of more than 1,000 or 2,000 m above sea level occupy 58 % and more than 33 % of the national territory, respectively. The average altitude here is 4,500 m, whereby the average altitude of ridgeline is 5,500 m. Mountains with a more than 5,000 m of height above sea level are covered with snow all year round.

### ***35.2.2 Climatic Characteristics***

The unique climate characteristics of the frigid plateau region are mainly as follows: low temperature, large temperature difference, hypobaric hypoxia, and strong ultraviolet radiation.

#### **35.2.2.1 Low Temperature**

Temperature decreases with elevation at a rate of about 0.6 °C for 100 m. The Tibet Plateau's average elevation is more than 4,500 m, and its annual average temperature is around -6 °C. The lowest temperature can reach -46 °C. Areas of more than 5,000 m of height above sea level are covered with snow all year round. The temperature here is below 0 °C, among which even existing are -30 °C low-temperature areas. People have to wear winter dresses for the sake of living and training.

#### **35.2.2.2 Large Temperature Difference**

Mountains at plateau areas have perennial snow on the top, dense forests at mountainside, and evergreen pastoral at piedmont. Temperatures between mountains and valley, sunny place and shady place differ a lot. In addition, the

temperature difference between day and night is up to 15–30 °C due to the poor atmospheric insulation caused by thin air.

### **35.2.2.3 Hypobaric Hypoxia**

Atmospheric pressure decreases with elevation. At sea level, the atmospheric pressure and atmospheric oxygen partial pressure are 101.2 and 21.2 kPa, respectively. At an elevation of 3,000 m, the atmospheric pressure and atmospheric oxygen partial pressure drop to 77.3 and 14.7 kPa, separately, accounting for 70 % of atmospheric pressure at sea level. When rising to 4,500 m above sea level, the atmospheric pressure will fall to around 60 % of the atmospheric pressure at sea level.

### **35.2.2.4 Strong Ultraviolet Radiation**

With ascending of elevation at the frigid plateau region, the air will become thinner and the atmosphere will get weaker for trap so that the ground will receive stronger sun rays and higher UV radiation. Generally, UV radiation increases with elevation at a rate of about 1.3 % for 100 m. At an elevation of 4,000 m, the UV radiation is 1.5–2.5 times stronger than that at sea level [1]. Moreover, snow ground will further increase the killing effect of radiation.

## **35.3 Effects on Operation Staffs Casted by the Frigid Plateau Environment**

The operation staffs will show adverse effects under the unique environment of frigid plateau, which will also impede the operation staffs to work normally by affecting their psychological and physical quality and professional skills. The following items are adverse effects:

### ***35.3.1 High Psychological Pressure***

Operation staffs at frigid plateau region see higher unhealthy psychological values than that in inland in terms of fear, anxiety or depression, and so on, as one research shows. The following three aspects are its main manifestation: First is fear. Because of the harsh climate at frigid plateau region, the function of human body will decrease significantly. Symptoms like anhelation, insomnia, irritability, and morbus asthenicus are very common, making operation staffs fear in plateau environment

more likely. The second is anxiety. The operation staffs' over-anxieties will go for self-security because of the experience of altitude sickness and high disease incidence of frostbite, skin cancer, and cataract. Last is depression. As the frigid plateau region is a remote place with complex social environment, and add up the troop's long-term closed management, the operation staffs are prone to be depressed.

### ***35.3.2 Slowness at Observing Response***

Firstly, under hypoxic environment at plateau areas, the operation staffs are apt to suffer altitude sickness such as anhelation and dizziness, leading their responding ability to visual stimulation, observation capability decrease, and attention disperses. Secondly, bright light and high UV radiation can harm visual organs, especially working above the snow line. The ultraviolet radiation is very high on snow ground, which can easily cause conjunctivitis, snow blindness, etc., so the operation staffs' observation capability will decrease, or even be deprived.

### ***35.3.3 Slowness at Critical Thinking***

Because the human brain stays in inhibitory condition for lack of sufficient oxygen at plateau areas, its judgment capability to external stimulation will significantly decline, casting a direct impact on operation staffs' thinking agility and continuity so that the operation staffs will show slowness at critical thinking. Moreover, as the temperature changes greatly, the operation staffs will suffer from frequent fatigue, poor reaction ability, and decline of memory, making the job efficiency reduce by 20–50 %. Comparing with peers working in the plains, their strength and energy are inferior for 3–5 years [2].

### ***35.3.4 Operation Constraint***

Firstly, the hypobaric hypoxia environment restricts the operation staffs' exercise capacity. Human's heart bearing capacity in plateau is just like carrying 20 kg in weight in the plains. Strenuous exercise will cause headaches, chest distress, tinnitus, and other symptoms; secondly, low temperature and bright light are two main factors that have adverse impacts on accuracy of the operation. Low temperature may reduce the joint flexibility and accuracy of muscle movement, and the average temperature there is around  $-6^{\circ}\text{C}$ . Long-term working in low-temperature environment will make the operation staffs clumsy in operation or even make errors.

Meanwhile, bright light and snow reflection are very likely to cause people visual fatigue, making the operation staffs make misjudgment or false judgment on signals and data during operation.

## **35.4 Countermeasures to Adapt to the Environment**

The harsh climate is the primary factor restricting job performance as it calls for much higher requirements of operation staffs' mental fitness, physical skills, and integrated support capabilities. Therefore, for the purpose of improving job performance, we must explore innovative training methods so as to enhance the operation staffs' environmental suitability.

### ***35.4.1 Psychological and Behavioral Training to Improve Operation Staffs' Mental Fitness***

Psychological and behavioral training based on the environmental characteristics in the frigid plateau region has important practical significance for prevention and elimination of fear, anxiety, depression, and other negative psychologies, as well as enhancement of operation staffs' mental fitness.

One way is to launch limit training to overcome fear, helping operation staffs to overcome psychological barrier, stimulate their mental potential, and eliminate their fear to rigid plateau environment through limitation training such as hike, rock, and rope climbing. Helping operation staffs to adapt to various battlefield environments gradually by trainings like combat readiness and maneuver in simulated battlefield environment so as to overcome their fear toward tense situation at frigid plateau region.

The second way is self-control training to relieve anxiety. In order to eliminate anxiety, guide the operation staffs to use self-control method to regulate physiological and psychological changes. There are two main ways: First is relaxation training, meaning that relaxing the muscle consciously to adjust the tension of the body so that the operation staffs' physical and mental coordination and mental balance can be maintained [3]. The second way is suggestive training. The operation staffs can imply themselves with words "I'm great," "People can, I can," etc. Positive verbal suggestion is helpful to eliminate anxiety and be optimistic.

Third is outward development to eliminate psychological depression. It is conducive for operation staffs to develop positive attitude and effectively reduce the incidence of depression, mental illness through trust fall, force impact, and high-altitude climbing, or some auxiliary trainings created based on the characteristics of

their profession. All of these trainings are designed to develop operation staffs' collaboration awareness and enterprising spirit and to further strengthen the collective sense of honor and self-fulfillment.

### ***35.4.2 Hypobaric Hypoxia Training to Enhance Physiological Suitability to Frigid Plateau Region***

Hypobaric hypoxia training may enhance the operation staffs' physical fitness on the one hand and reduce the adverse effects of the harsh climate and environment on the other. According to the operation staffs' physiological characteristics and training rule, the hypobaric hypoxia training mainly includes three stages:

First is to strengthen basic trainings at low altitude. At low-altitude regions, pay special attention to basic theoretical study and basic fitness training. The first step is to learn about environmental characteristics of the frigid plateau region and possible physiological responses under hypobaric hypoxia environment and master countermeasures to cope with. Then, conduct the basic fitness training. The training subjects include the following: long-distance running and cross-country run with full equipment and so on. The training time shall not be less than 2 h every day, and the training phase shall not be less than 4 weeks [4].

Second is stepwise adaptive training. This kind of training is mainly carried out at an altitude of less than 3,000 m in accordance with the order: unarmed, lightly armed, and burdened. It is designed to adjust the operation staffs' heart-lung functions so as to enhance their ability to adapt to hypoxia environment through fitness and breathe control trainings.

The last way is to conduct high-altitude applied trainings. Applied training is such a kind of comprehensive training for operation staffs to ensure the successful completion of their tasks. This method shall highlight trainings like camping at cold plateaus, field survival, and special skills for the sake of improvement of the operation staffs' technical and tactical ability. During the group training process, it should also combine with breath control trainings, integrating hypobaric hypoxia training, technical and tactical training, and mental and fitness training as one.

### ***35.4.3 Professional Skills Training with Specific Aim at Frigid Plateau Region***

Under the frigid plateau environment, the operation staffs will be seriously affected in terms of use of the equipment, resulting in increased rates of operational errors and ineffective performance of equipment, which will reduce the job performance. Therefore, professional skills training with special aims can effectively enhance the staffs' ability to operate equipments in harsh environments.

Professional skills in harsh environments will improve job performance significantly. One is cold outdoor training. It is used to enhance the staffs' ability to adapt to conditions at low temperatures; another is trainings at higher altitudes, where the air is thin. The purpose of this training is to strengthen the staffs' adaptability under anoxic conditions, and third is trainings on snow ground under strong sunlight to enhance the staffs' operational ability in bright light.

#### ***35.4.4 The Equipment and Logistics Support Shall be Always Ready to Ensure Safe and Efficient Operation in Harsh Environments***

In order to ensure safe and efficient operations in frigid plateau region, it is a must to carry out equipment and logistics support drill with the health service, quartermaster, and equipment support as a highlight, minimizing the adverse effects caused by the harsh environment.

First is to strengthen health service support. The first way is to establish a health record, organizing the staffs to do regular physical examination to learn their body conditions in a timely manner; next is to maintain the staffs' mental health. Issue promotional materials on psychological adjustment, carry out extensive mental health education, and invite psychiatrist regularly; then, keep sanitation and prevent diseases. Put more efforts to prevent and control communicable diseases, vaccinate the staffs intentionally, and prepare decoction of traditional Chinese medicine. Finally, keep all medicine used at plateau in place. Distribute the first aid packet to all staffs before the job, and tell them the time of taking medicine and dosage clearly.

The second way is to have a scientific and reasonable diet. As the heat consumption at plateau is 10–15 % higher than that in plain, the amount of energy supply at plateau shall be about 10 % higher than that in plains [5]. The staple and side food shall be cooked or hot food with high sugar, high protein, and low fat. Fresh vegetables and fruits are recommended to be eaten more. For region lacking of vegetables, various vitamins shall be provided [6]. Drinking hot water with a small amount of salt to supplement energy consumed.

And the last way is to prepare the equipment fully furnished. Since the plateau lacks oxygen, every staff shall be equipped with a portable oxygen bag, and every group shall be equipped with small portable oxygen bottle, so that when the staffs suffer hypoxia seriously, they can relieve symptoms timely; since there is abundant intense sunlight and snow glacier, the staffs shall wear eye protection glasses to prevent eyes from being burned, and since the ultraviolet radiation here is strong, the staffs shall wear sunscreen for fear of solar dermatitis or other skin diseases.

## 35.5 Conclusions

The Tibetan frigid plateau region has harsh climate and complex geographical environment, which affect the operation staffs' physiology, psychology, and behaviors to a variable extent. Therefore, in order to improve the operation staffs suitability under frigid plateau environment to ensure effective job performance, it is a must to launch various adaptive trainings with the psychological and behavioral training, hypobaric hypoxia training, professional skills training, and equipment and logistics support drill as highlights.

## References

1. Pang Z, Li H (2012) Operation application method of HQ-7B surface to air missile system on highland. Air Defence Forces Academy Press, Zhengzhou
2. Feng T, Tang X (2011) The impact and countermeasures of electronic warfare equipment in cold alpine environment. *Science and Technology Information*, p 36
3. Zhang Y (2012) Research of psychological behavior training on plateau area. *Modern Arms*, p 46
4. PLA General Staff Headquarters (2010) Army infantry training materials. PLA Press, Beijing
5. Du K (2012) Soldiers' diet and dietary on plateau area. *Quartermaster*, pp 58–59
6. Wang D, Feng J (2012) The difficulties and countermeasures of medical support to forces on plateau area. *Armed Police Medical*, pp 541–542



# Chapter 36

## Features of Selection Indicators for Alpine Plateau Operator

Cheng Jin, Zhibing Pang, Honglei Li, Jiang Wu,  
Hua Li and Quanliang Yin

**Abstract** In order to take better advantages of weaponry technical performance, and improve martial effectiveness, the most important thing is the man-machine combination, that is, the selection of weapons and equipment operators. Plateau environment is one of the most important military combat environments in the future. With the background, this thesis takes the selection of weapons and equipment operators as the study object, to analysis how the environment influence the operational capability and studies the characteristics of high altitude region operator selection index system. It provides an essential basis to the selection of the operators master in antiaircraft weapons equipment with the plateau environment to a scientific extent.

**Keywords** Altitude environment · Operator selection · Indicators features

### 36.1 Introduction

Modern war is the system-system against between the comprehensive effectiveness of man-machine system, composed of personnel and weaponry, whether the human-machine combination can be matched, and whether it is the key factor to taking advantage of weaponry [1]. Operator selection is expected to elect competent operator for specific weapons from the military population. It is for composition the characteristics of personnel and weaponry organically, making up efficient human-machine systems, to increase the reliability of the system. Essence of the selection is to find the best combination of weapons and people [2]. The paper takes plateau environment as the background, typical Air Defense Forces operator weaponry as the research object, based on the needs of my antiaircraft

---

C. Jin (✉) · Z. Pang · H. Li · J. Wu · H. Li · Q. Yin  
Air Defence Forces Academy, Zhengzhou 450052, China  
e-mail: fkb\_mmes@163.com

forces modernization study to explore the characteristics of the index operator selection, operator selection and training of a certain degree of guidance.

## **36.2 High Altitude Environment [3]**

### ***36.2.1 Low Air Pressure, Low Oxygen Partial Pressure***

The atmosphere surrounding the earth presents lower the air pressure regularly, with the increase of the altitude. Generally speaking, altitude increases 100 m as average, pressure decreases about 0.67 kPa (5 mmHg). However, the atmospheric oxygen content as a percent of 20.93 % is maintained substantially constant. So, as the altitude increases, the oxygen partial pressure with decreasing pressure also showed reduced regularity.

### ***36.2.2 Frozen, Windy, Low Temperature***

The altitude increases as the temperature decreases, generally increasing by 100 m, the temperature dropping 0.6°, regardless of latitude. In addition, most highland areas are less affected by the monsoon ocean, and are in continental climate with low temperatures and large temperature between day and night mostly. Moreover, with altitude increasing, speed of wind increases, resulting in discomfort to the human body. Simultaneously with altitude increasing, the water vapor content in the air reduces, and the absolute humidity of the air reducing, air drying, cause thirst, dry skin normally.

### ***36.2.3 Solar Radiation Intensity, Long Hours of Sunlight, Strong Ultraviolet Radiation***

As the altitude increasing and the atmosphere through the brightness increasing, the transmittance of solar radiation increases, so does the solar radiation. Each 1,000 m the elevation increasing by 10 % of the solar radiation enhancement occurs generally, snow will increase the intensity of solar radiation, so does the intensity of the ultraviolet as the reflective thin air and snow at the same time. UV intensity is 1.5–2.5 times of the plains at an altitude of 4,000 m in altitude.

### **36.3 Impact of High Altitude Environment on Man's Capabilities**

The old military saying “to occupy the commanding height” illustrates that strategical highland has the advantage of observing, firing at areas nearby and defense. However, highland has the problems and bumpiness, small population, inconvenient transportation. At the same time, it is lacking in food, water resources and fuel. Apart from geographical problems, there also comes the influence of dreadful climate conditions. Bodies cannot take in enough oxygen because of the high altitude of 3,000 m. Those will all affect people's health and working ability, which also leaves undesirable impacts on military work.

#### ***36.3.1 Impact on the Visual and Auditory Sense***

In the plateau region, most operators' vision will fall. One fifth among them will have an obvious diminution. That is because vision is the most sensitive to hypoxia. The vision acuity and the identity of color begin fall above 3,000 m. And in the case of lacking in oxygen, the time to react will be prolonged. Simultaneously, the capability to adapt dark is declining. In turn, the weakened capability of vision acuity could partly result in ability of operation's reducing. However, it makes no much difference to the hearing sensitivity.

#### ***36.3.2 Impact on Intelligence, Memory and Concentration***

In the environment above 4,000 m, most operators appear to show the trend that their abilities such as observation, temporary memory, concentration and reaction become weakened. As far as intelligence is concerned, there is a conspicuous relationship between the influence extent and the altitude as well as the speed of rising. It is widely recognized though many intelligence abilities start to decline over 3,000 m high, people can still complete the missions which have been known well. Memory is sensitive to hypoxia as well. With the rising altitude, the growing severity of hypoxia leads to different extents of memory damage. Being lack of oxygen, a man's concentration drops apparently. It becomes difficult for him to concentrate, and, the shifting and distribution of attention is blocked.

### ***36.3.3 Impact on Emotional State***

Exposure to high altitude environment probably results in enjoyment and a wrong judgment. It shows that, by a test, after staying one to 4 h around altitude 4,000 m, those be tested judged themselves as “not very friendly” but “having a clear thinking,” feeling “tired” and “confusing” as well. These emotional performances of high altitude have a conspicuous time process. And all the emotional changes will return to normal after 48 h [4].

### ***36.3.4 Impact on Personality***

Impact on personality is proportional to altitude and time spent at high altitudes. In 3,000–4,000 m usually occurs neurasthenia, manifest as fatigue, lack of motivation, decreased sensitivity and other psychological symptoms. In 4,000–7,000 m, it is easy to appear manic depression. Over 7,000 m, acute cerebral edema can cause damage to the central nervous system structure and function [5].

### ***36.3.5 Impact on Work Effect***

Studies have shown that cognitive ability is more easily to suffer influence of diminution than the movement capability. Complex assignments get earlier influence than those simple. Those activities that need making a strategic decision or making tactics are more easily to get affected than the auto-movement process. Recently learned work operation is more likely to suffer influence than the adept object operation. In the high altitude region, the visual input of shape, pattern and outline is more easily to get affected compared with that of figures, characters and characteristic. What is more, the lowest altitude to affect most work assignment is around 3,050 m. Especially above 4,000 m, compared with the lower altitude, the phenomenon of errors increasing and time prolonging occurs. Simultaneously, they are more willing to reduce the rate of reaction so as to keep the error rate a low level.

### ***36.3.6 Impact on Labor Ability***

In the plateau region, labor heart rate significantly increased, heart rate recovery time prolonged and becomes more obvious as height above sea level increases. Therefore, manipulator is relatively easier to feel fatigue, and the amount of work compared with the plain region has a certain decline, extending their work time.

Generally speaking, on the plateau at an altitude of 4,000 m, the ability to work down a labor grade than on the plain, that is when engaged in moderate intensity of labor in the 4,000 m plateau, the cardiac load is equivalent to that when engaged in heavy labor intensity in the plains.

## **36.4 Operator Selection Index Test and Characteristics**

### ***36.4.1 Index Test [6]***

A unit of 46 randomly selected operators in Tibet as test subjects, all male, were tested at the age of 18–30 years, mean age was 22.7 years old, height 162–183 cm, the average height of 171.29 cm.

#### **36.4.1.1 Basic Test Case**

The tests include: height, weight, resting heart rate, blood pressure and lung capacity.

#### **36.4.1.2 Operation Proficiency Test**

Test content is in accordance with the assessment of military training syllabus content relevant conduct military training.

#### **36.4.1.3 Mental Ability Tests**

The tests include: digital memory ability test, while the graphics and memory tests and complex reaction test.

#### **36.4.1.4 Test Cassette 16 Personality Factors**

Test content is 16 kinds of human personality factors which include: warmth, intelligence, stability, aggressiveness, excitement, persistence, boldness, sensitivity, doubt, fantasy, sophistication, anxiety, experimental, independence, self-discipline and tension.

## **36.4.2 Characteristics**

### **36.4.2.1 Basic Test Case**

Plains and highlands operators in static spirometry showed significant differences. This is because the low partial pressure of oxygen plateau environment, personnel exhaled volume decreases, resulting in significantly smaller lung capacity, which may cause the heart rate when the job growth is too fast, the recovery time after the operation of the phenomenon, resulting plateau operator in strength, endurance and resistance fatigue capabilities are relatively worse when the plains .

Therefore, in the selection of Air Defense Forces typical plateau operator, operator must take full account of endurance and resistance to fatigue.

### **36.4.2.2 Operation Proficiency Test**

Cognitive ability is more susceptible to hypoxia than psychomotor skills. Complex tasks are affected earlier than the simple task; work operating a newly learned task than the skilled operator vulnerable. At high altitudes, shapes, patterns and contours visual input than numbers, text and features more susceptible to visual input.

### **36.4.2.3 Mental Ability Tests**

Plateau operator subject to the environmental impact due to the year-round, in the digital short-term memory capacity, pattern recognition and memory capabilities, moving target search to locate and attention allocation, and response speed is worse than the plains operator.

### **36.4.2.4 Cattell's 16 Personality Factor Test**

There is a large difference in the intelligence where people in plain areas have an advantage. It states a fact that compared to operators in at high altitude, operators in the plain areas not only have higher levels of education, culture and ability to learn and understand, but also smarter and possess a stronger capacity to think abstractly with bright brain.

There is a large difference in dominance where people in plain areas have an advantage. It states a fact that compared to operators in at high altitude, operators in the plain areas are feistier, more independent and could insist their perspectives regardless of whatever the environments are. What is more, they have challenging spirit, competitive and more aggressive and stubborn.

There is a large difference in excitability where people in plain areas have an advantage. It states a fact that compared to operators in at high altitude, operators

in the plain areas behave easily and little stiff, as a result of which, they are more enthusiastic, lively and talkative meeting things.

There is a large dutifulness in excitability where people in plain areas have an advantage. It states a fact that compared to operators in at high altitude, operators in the plain areas do their bits and with a strong sense of responsibility, do not complete matters in a perfunctory way.

There is a large anxiety in excitability where people in plain areas have an disadvantage. It states a fact that compared to operators in at high altitude, operators in the plain areas take calm actions, equipped with confidence and sense of security and adapt to the environment with ease.

## 36.5 Conclusion

Complex geographical environment of high altitude alpine region and the impact of adverse weather conditions combat weapons and people of very large, which we should lay emphasis on. Through the research on the characteristics of the selection of the operator, enhancing adaptability to complex environment and improving mental and physical qualities of people in complex environments so that people fully combine with weapons systems in combat, improving man-machine combination efficiency, maximizing operational effectiveness of weapon systems and providing strong support for fighting and winning under the condition of information war.

## References

1. Tian J (2004) Fuzzy comprehensive evaluation in the equipment operation with hand chosen. Fire and command control, 2004 fifth
2. Pang Z (1992) Measuring hand skill production. People's Liberation Army press, Beijing
3. Huang C (1999) Military training medicine. People's Medical Publishing House, Beijing
4. Miao D et al (2004) Manual of military psychology. Chinese Light Industry Press, Beijing
5. Ding X (2001) Psychometric. Henan University Press, Kaifeng
6. Niu K (2006) Modeling and software of air defense operation typical hand selection of implementation of a master. Air Defense forces Command academy

# Chapter 37

## Research on the Correlation Between University Students' Assessment of Sports Environment and Their Physical Exercises Behavior

Min Chen, Jing Sun, Jianjun Li, Shuai Mu, Xiang Gao, Yang Yang, Tian Yang, Ming Kong and Miaofei Chen

**Abstract** In order to analyze the relation between the sports environment of universities and university students' physical exercises, the researchers, starting from the analysis of the university students' assessment of sports environment, adopt various methods such as questionnaire and data statistics to study this subject and find out: First, 76.1 % students do not have good habit on sports exercises. Only 23.9 % students are qualified for the National Sports Population Evaluation Criteria (Tan in J Guizhou Coll Nationalities Philos Soc Sci Ed 2, 2008) [1]. Second, students in different physical exercise behavior groups have different assessments on their universities' sports environment. Specifically, the more actively a student involves in sports exercises, the higher assessments he will give. Third, students' physical exercise behavior and their assessment on sport environment belong to low correlation, while the environment and students' physical exercise behavior belong to positive correlation.

**Keywords** Sports environment · Physical exercises behavior · Correlation

### 37.1 Introduction

The students' assessment on university sports environment refers to the evaluation on sports environment carried out by students by adopting both their subjective and relatively objective criteria, and reflects their points of views and attitudes on sports

---

M. Chen (✉) · J. Li · S. Mu · X. Gao · Y. Yang · M. Kong · M. Chen  
PLA Air Defense Forces Academy, Zhengzhou, People's Republic of China  
e-mail: 780239720@qq.com

J. Sun  
Nanjing Sport Institute, Nanjing, China

T. Yang  
Nanjing University, Nanjing, China



environment. According to the psychology, attitude can affect people's behavior. Therefore, starting from the analysis of the university students' assessment of sports environment, the researchers try to investigate the relation between students' physical exercises behaviors and their views on universities' sports environment so as to offer theoretical foundation for the universities so that they could better sports environment to make students participate more in physical exercises.

## **37.2 Research Object and Method**

### ***37.2.1 Research Object***

Researchers handed out questionnaires to 1,400 students from Nanjing Institute of Physical Education, Nanjing University of Science and Technology, Nanjing Agricultural University, Nanjing Normal University, Nanjing University of Finance and Economics, Nanjing University, and Nanjing University of Technology. A total of 988 questionnaires were retrieved and the retrieving rate is 70.57 %.

### ***37.2.2 Research Method***

#### **37.2.2.1 The Method of Questionnaire**

The researchers consult various materials to design "The Questionnaire of University Students' Assessment of Sports Environment and Their Physical Exercises Behaviors."

#### **37.2.2.2 The Method of Mathematical Statistics**

The researchers use SPSS16.0 software to analyze the collected data.

## **37.3 Research Results and Analysis**

### ***37.3.1 The Present Situation of the Physical Exercise Behavior of University Students in Nanjing***

As an important indicator to measure the mass sports in a country or region, the concept of "sports population" is mainly evaluate how many people participate in physical exercises and how often they involve themselves in. In 1997, China brought up the criteria of "sports population." Each "sports population" must

**Table 37.1** Physical exercise behavior groups

Type of physical exercises	Criteria		
	Frequency/ week	Time	Intensity
Group A	0	Above 30 min	Equal/above physical fitness
Group B	1	Above 30 min	Equal/above physical fitness
Group C	2	Above 30 min	Equal/above physical fitness
Group D	3	Above 30 min	Equal/above physical fitness

satisfy three basic conditions: to take part in physical exercises for at least three times a week; the duration of each exercise should above 30 min; and the working load or intensity must equal or above one's physical fitness [2].

Based on the criteria of the "sports population," we divide students into four different groups, which can be seen in Chart 1.

The research statistics on students' physical exercises behavior are counted and clarified into Table 37.1.

Currently, "sports population" in China consists of two parts: one is called "definite sports population" which includes armed forces, students and people who are sports profession; the other is called "possible sports population" which refers to the adults above 70 years old who participate in sports exercises regularly [3]. According to Table 37.1, only 23.90 % students are qualified for the criteria of "sports population," which means students' physical exercise behavior should be concerned and improved.

### ***37.3.2 The Present Situation of the Assessment on Sports Environment Made by Students in Universities in Nanjing***

In order to get a better understanding of students' assessment on their universities' sports environment, researchers clarified the information which can be seen in Table 37.2.

After T-testing the samples, researchers find there is a remarkable difference in students' assessment on universities' physical education, sports activities and competitions, and rules and management.  $P = 0.00$ . Differences also exist in the assessment collecting from different groups. Group C gets the highest score, 3.04; while group A gets the lowest score, 2.64. This shows that students in different behavior groups have different evaluation on sports environment. The more active they are, the higher score they give. Therefore, to improve students' enthusiasm in sports, universities should improve their sports environment so as to satisfy them and make them more involved in sports activities.

**Table 37.2** The assessment on sports environment made by students in different groups

Sports environment assessment elements	Different physical exercise groups (M ± SD)				P
	Group A	Group A	Group C	Group D	
Natural environment	3.67 + 0.502	3.84 + 0.567	3.88 + 0.576	3.91 + 0.539	0.467
infrastructure	3.125 + 0.44	3.253 + 0.53	3.454 + 0.94	3.502 + 0.43	0.083
Physical education	3.29 + 0.342	3.62 + 0.391	3.81 + 0.392	3.96 + 0.404	0
Sports associations	0.00 + 0.00	3.34 + 0.43	3.30 + 0.43	3.58 + 0.475	0.119
Sports activities and competitions	3.16 + 0.256	3.32 + 0.407	3.41 + 0.41	3.59 + 0.385	0
Rules and management	3.27 + 0.327	3.28 + 0.377	3.45 + 0.385	3.55 + 0.466	0.001
Sports information	2.64 + 0.465	2.86 + 0.611	3.04 + 0.599	2.95 + 0.603	0.046
Scores on sports environment assessment	200.75 + 18.86	213.55 + 19.81	227.71 + 22.88	233.53 + 25.58	0

### ***37.3.3 The Relation Between University Students' Assessment on Sports Environment and Their Physical Exercise Behavior***

In order to find the elements which affect the relation between university students' assessment on sports environment and their physical exercise behavior, researchers adopt Pearson's analysis method in SPSS16.0 software [4].

#### **37.3.3.1 The Analysis of the Relation Between University Students' Assessment on Sports Environment and Their Physical Exercise Behavior**

According to Table 37.3, the relation between students' assessment on sports environment and their physical exercise behavior belongs to positive correlation.  $P = 0.000 < 0.01$ , which means students' physical behavior is positively correlated with other elements in Table 37.3. However, there is one exception that the natural environment and students' physical exercise behavior are not positively related. Therefore, we should be aware that sports environment is an integrated system rather than isolated parts.

**Table 37.3** University students' assessment on sports environment and their physical exercise behavior

	Correlation	Overall scores of sports environment	Natural environment	Sports infrastructure	Physical education	Sports associations	Sports activities and competition	Rules and management	Sports information
Behavior	Pearson correlation	0.381**	0.089	0.156*	0.394**	0.201**	0.285**	0.243*	0.120*
	Distinctiveness(both sides)	0	0.163	0.014	0	0.001	0	0.048	0.046

Note \*\*0.001 = positive correlation; \*0.05 = positive correlation

### **37.3.3.2 The Analysis of the Relation Between University Students' Assessment on Sports Environment and Their Physical Exercise Behavior**

Table 37.4 is made according to the research of students of different genders.

The author concludes that the total score of boys and girls' sports environment assessment is significantly associated with their physical exercise behavior, and the difference  $P = 0.000 < 0.01$ . The boys' physical exercise behavior is significantly related to the sports teaching environment assessment, sports activities and competition environment assessment, sports rules and regulations and management and information assessment performance. Girls' physical exercise behavior does not have much bearing on the natural environment, sports infrastructure, sports information as well as environmental assessment score. It can be found that students' physical exercise is greatly influenced by the environment of sports teaching, sports competition as well as sports rules, regulations and management.

### **37.3.3.3 The Relativity Between Sports Environment Assessment of College Students from Different Grades and Their Physical Exercise Behavior**

Having analyzed the relativity between sports environment assessment and students' physical exercise, the author has made Table 37.5 on the basis of the statistics sorted out.

From the table, the author find a strong and positive correlation between sports environment assessment of freshmen, sophomore and junior students and their physical exercise, while for senior students the correlation is relatively weak. The author also find that the sports exercise of students from different grades is significantly correlated with their sports assessment while is least correlated with natural environment assessment.

## **37.4 Conclusions and Suggestions**

### ***37.4.1 Conclusions***

#### **37.4.1.1 Students Should Account for the Small Part of "National Sports Population"**

Considering the frequency, length and intensity of college students' physical exercise in universities in Nanjing, their prospect of physical exercise is not optimistic with only 23.9 % reaching the relevant standards.

**Table 37.4** The relativity between sports environment assessment and the physical exercises of students of different genders

Gender categories	The correlation performance	The natural environment	Sports infrastructure	Sports teaching	Sports organizations	Sports competition	Sports rules and regulations and management	Sports information	Environmental assessment score
Boy's physical exercise behavior	Pearson dependency Significant (both sides)	0.035	0.123	0.360**	0.11	0.323**	0.286**	0.080*	0.321**
Girl's physical exercise behavior girl	Pearson dependency Significant (both sides)	0.154	0.134	0	0.179	0	0	0.033	0
	Pearson dependency Significant (both sides)	0.132	0.191	0.386**	0.287**	0.221*	0.215*	0.132	0.405**
			0.061	0	0.004	0.03	0.034	0.197	0

**Table 37.5** The relativity between sports environment assessment of students form different grades and their physical exercises

Grade type	The correlation performance	The natural environment	Sports infrastructure	Sports teaching	Sports organizations	Sports competition	Sports rules and regulations and management	Sports information	Environmental assessment score
A freshman exercise behavior	Pearson dependency	0.151	0.255	0.379**	0.248	0.172	0.172	0.137	0.426**
	Significant (both sides)	0.258	0.054	0.003	0.061	0.196	0.196	0.304	0.001
Sophomore exercise behavior	Pearson dependency	-0.058	0.223*	0.462**	0.129	0.187	0.359**	-0.003	349**
	Significant (both sides)	0.603	0.042	0	0.242	0.164	0.001	0.981	0.001
Senior exercise behavior	Pearson dependency	0.151	0.157	0.460**	0.464*	0.516	0.466*	0.428*	0.568**
	Significant (both sides)	0.305	0.286	0.001	0.043	0.053	0.041	0.026	0
Junior exercise behavior	Pearson dependency	0.207	0.087	0.303*	0.016	0.347**	0.17	0.052	0.201*
	Significant (both sides)	0.122	0.519	0.022	0.905	0.001	0.205	0.698	0.034

Note \*\*In 01 level significantly correlated (bilateral); \*At 0.05 level (double side)

#### **37.4.1.2 The Better the Students' Physical Exercise Behavior Is, the Higher the Indexes of Sports Environment Assessment Are**

Concluding the comments from students for the sports environment in their universities, the author found that the better the students' physical exercise behavior is, the higher the indexes of sports environment assessment are. Students with positive attitudes toward physical exercises are usually not particular about the sports environment in their universities, and therefore their consent with the environment will improve.

#### **37.4.1.3 Every Environmental Factor in Sports Environment Matters**

The comments of the sports environment from students in universities is low correlated with their physical exercises, while there is a positive correlation when  $P = 0.01$ . The physical exercise behavior of different groups of students is significantly related to the assessment of physical teaching environment and the sports club organization environment as well as sports competition. Relatively speaking, the correlation between physical exercises and the environment of sports facility and sports information is not so significant while the correlation between physical exercise behavior and natural environment is least significant.

### ***37.4.2 Suggestion***

#### **37.4.2.1 Universities Should Deepen the Reform of Physical Education and Cultivate Students' Positive Attitude Toward Physical Exercise**

Universities should vigorously carry out the target of cultivating students' habit of doing physical exercises and help them to develop a positive and efficient way of physical exercise. They should also raise students' awareness and recognition of physical exercise, enabling them to foster a positive value of physical exercise.

#### **37.4.2.2 Universities Should Attach Importance to the Function of Sports Environment in Fostering the Students' Physical Exercises**

The fundamental steps to improve students' consent for the sports environment in their universalities should start from enhancing the construction of sports facility on campus [5]. Universities should improve the infrastructure for the following aspects.



- Universities should provide better sports environment for students to do exercises and open the sports halls regularly.
- PE teaching should stimulate students' interests and cultivate their habits of doing exercises. It should also set up various forms of exercises for students, improving the entertainment while building their bodies.
- Regulating the standards for physical texts and improve the basic requirements for students.
- Sports information environment is a weak link in sports environment, thus more efforts should be made to improve the information environment. For example, channels for sports events should be provided and guaranteed.
- Better convenience should be provided for students to make use of the Internet resources to get information of sports events.

### **37.4.2.3 Families and Society Should Pay Attention to the Cultivation of Students' Physical Exercise [6]**

Cognitive behavioral theory suggests that the sports environment in school, family and society can influence students' subjective efficacy and therefore their behavior. Thus, the task of changing the habit of students' physical exercise should not only be achieved by universities but families and the society.

## **References**

1. Tan Y (2008) Analyses Guizhou University sports environment. *J Guizhou Coll Nationalities Philos Soc Sci Ed* (2)
2. Shi Z, Tian Y (2005) Information era system concept of sports teaching environment. *J Capital Inst Phys Educ* (3)
3. Chang S (2003) College students' physical exercise behavior research. Ph.D. degree theory, Shanghai Sports Institute, Shanghai
4. Zhou D (2004) School sports learning. People's sport publishing house, Beijing, pp 413–431
5. Deng Y (1995) Theory of school physical education environment and construction. *J Sichuan Sports Sci* 1:36–39
6. Huanyu X (2005) Buddhistmas. The concept of sports population, classification and statistical standards. *J Sports Sci Res* (1)

# Chapter 38

## Friction Behaviour of Medical Compression Stockings Against Various Mechanical Skin Models

Wei Ke, Jiyong Hu and Xin Ding

**Abstract** To determine a promising skin model for exploring the friction behaviour of medical compression stockings (MCS), the dynamic friction properties of MCS against with two kinds of mechanical skin models are investigated in the current study. For further investigation, the difference on the friction of the two models are analysed in detail with adhesion friction model and Hertz contact theory. The coefficient of friction (COF) of MCS/Lorica is  $0.34 \pm 0.01$ , which is closer to the COF of human skin/MCS ( $0.36 \pm 0.04$ ), while the COF of MCS/PUR is  $0.89 \pm 0.01$ , with an increasing factor of 2.6, mainly due to the variation of elastic modulus. It can be concluded that Lorica has similar dry friction behaviour as the human skin, and elastic modulus could be the main reason to the difference on the friction of two models.

**Keywords** Skin-textile friction · Medical compression stockings · Hertz contact model · Adhesion friction mechanism

### 38.1 Introduction

Medical compression stockings (MCS) is a kind of medical textile products, which has been widely used in compression therapy for reliving symptoms associated with venous disorders in lower human limbs [1]. It can perfectly alleviate the related limb diseases because of the defined pressure exerted on the limb skin, as well as generate unavoidable friction simultaneously. It is generally acknowledged that the friction from the inappropriate size of MCS (e.g. too tight) contact with skin during long-time wearing will produce skin injuries such as pressure patterns, blisters or ulcers [2]. Thus, the friction behaviour of MCS in contact with the skin

---

W. Ke · J. Hu (✉) · X. Ding

College of Textiles, Donghua University, Shanghai 201620, People's Republic of China

e-mail: huji@dhu.edu.cn

is an important factor. However, a lot of studies have just paid attention on the compression properties and therapeutic effect of MCS [3], with ignoring the friction properties of MCS contact with human skin.

To investigate the friction properties of textiles/skin and also avoid the uncontrolled factors from human skin, various objective devices using linear or rotational relative movements have been developed in the past [4]. Instead of using arbitrary materials such as steel [5] as the skin models in contact with textiles, the use of soft materials such as a polymer finger or a polyurethane (PUR) film [6] seems to be reasonable.

In previous study [7], in order to investigate the influence of surface topography on the friction of MCS, we have chosen PUR sheet as the candidate skin model to do the friction tests and theoretic work, for simplifying the contacts between MCS and human skin, but it is not entirely according to the realistic state. Then, Lorica, whose surface is similar to the forearm skin, was chosen as the skin model to exploring the friction properties of MCS in this study, and for comparison, a PUR sheet was used as a reference material throughout the study. For further investigation, Hertz contact model was used to explore the differences in detail.

## **38.2 Experimental**

### **38.2.1 Materials**

#### **38.2.1.1 Investigated Textiles**

A typical commercial knitted elastic textile of MCS (compression class 1, Ccell for short) was selected in this study. The material is composing of 52 % polyamide, 34 % spandex and 14 % cotton. The optical microscopic image and its surface topography were given in Fig. 38.1.

It can be seen that the structure of MCS is quite different from the other traditional socks, it includes two components: the inlaid or covered yarns and the knitted loops. The inlaid yarn is a synthetic elastic yarn with textile filaments wrapped around it. This component is inserted between the loops, which constitute the base structure of the fabric and play a key role in forming the topography of stocking samples.

#### **38.2.1.2 Mechanical Skin Models**

Two kinds of materials which are widely used as the mechanical skin models were selected in the experiment. One is a structured artificial leather, named Lorica showed similar surface structure as human skin (See Fig. 38.2a, b) which consists of a polyamide fleece with a PUR coating. The other one is a relatively smooth sheet made of PUR (Fig. 38.2c). The specifications of the two skin models are given in Table 38.1.

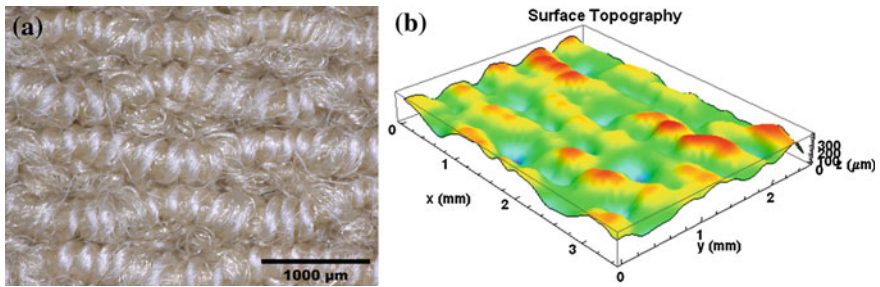


Fig. 38.1 The optical image of MCS (right) and its topography image (left)

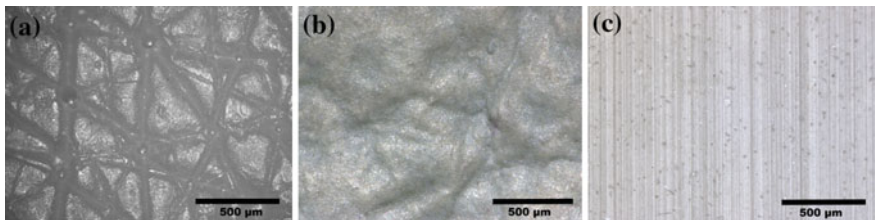


Fig. 38.2 The optical image of real forearm skin replica form the first author (a) and Lorica skin model (b) and PUR skin model (c)

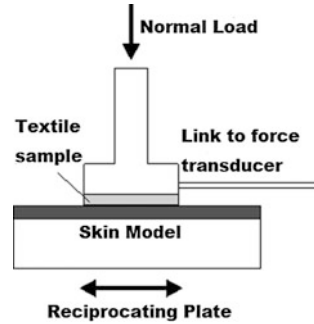
Table 38.1 Characteristics of materials investigated as skin models [8]

Material	Thickness (mm)	Roughness Ra (µm)	Hardness shore A	Elastic modulus (MPa)
Lorica	0.9	14.93 ± 1.73	42.5 ± 1.8	24.4
PUR	1	0.21 ± 0.02	70.2 ± 0.4	10.8

### 38.2.2 Friction Measurements

A friction tester described in [9] was used to investigate the friction behaviour of textiles. As Fig. 38.3 show it schematically. It includes an elevation arm whereby friction test functionalities can be implemented by measuring and controlling vertical load over an adjustable force range up to 20 N. The reciprocating motion of the metallic support is generated by a stepper motor which is operated by a programmable controller. Friction forces are measured using a highly sensitive quartz load cell with a maximum resolution 5 mN connected to a charge amplifier. Vertical forces are recorded using a strain-gauge force transducer with a maximum resolution of 10 mN. The position of the manoeuvrable weight can be changed in order to adjust the normal load. The weight is driven by a DC motor. The slider is flat and circular with a diameter of 28.5 mm, which results the surface area of

**Fig. 38.3** Set-up for friction measurements



about  $6.4 \text{ cm}^2$ . The MCS samples are attached to the slider by adhesive tapes and rubbed against the reciprocating support covered with a layer of skin models film.

The friction measurements were carried out under dry conditions in a laboratory with standard climate ( $20 \pm 1 \text{ }^\circ\text{C}$  and  $65 \pm 2 \%$  relative humidity). All the samples were pre-conditioned for 24 h with the same condition before testing. During the test, the MCS samples remained stationary while the skin model on its metallic support base underwent 550 linear friction cycles with a stroke of 20 mm and using an oscillation frequency of 1.25 Hz. The normal and the friction forces were measured continuously and simultaneously, and, thus, one set of friction data was determined for every 50 cycles.

To determine the load dependence of MCS surfaces, a series of applied normal loads, increasing from 0.5 to 8 N, were investigated in this experiment. The sliding direction is corresponding to the practical use of putting on the stockings which is in warp direction, vertical to the orientation of inlaid yarns.

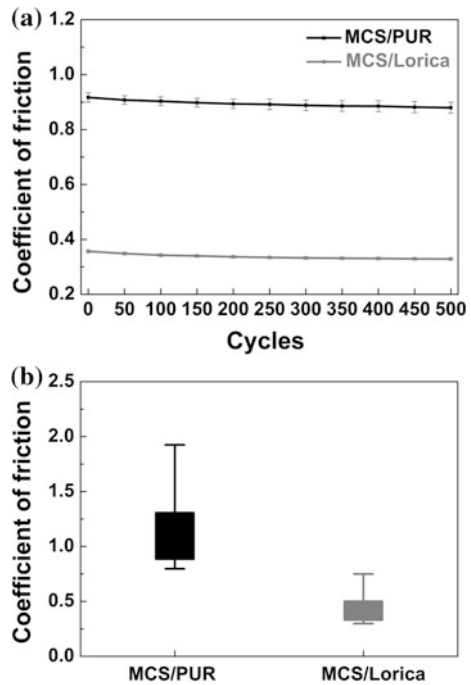
### 38.3 Results and Discussions

The coefficient of friction (COF) for MCS against with PUR and Lorica were assessed by rubbing the samples over 550 friction cycles, one typical result of friction coefficients is shown in Fig. 38.4a. Each data point represents the average COF (friction of coefficient) with standard deviation obtained from every 50 cycles.

Figure 38.4b shows the range sliding friction coefficients of MCS with various skin models. The friction coefficients measured from different skin models ranged from 0.80 to 1.92 in MCS/PUR and from 0.30 to 0.77 in MCS/Lorica. The friction coefficients have a significant difference on the two skin models. Compare to MCS contacting with PUR, the range of friction coefficients under MCS/Lorica were narrower and the value of friction coefficients are slower. These findings are in good accordance with the results of previous studies [8].

A pronounced load dependence was observed for the both, the higher friction coefficients were normally found with lower load. It is therefore unreasonable to

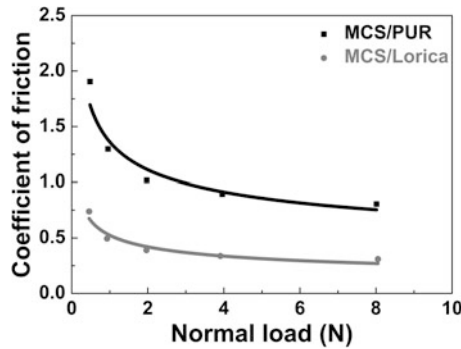
**Fig. 38.4** The coefficient of friction (COF) as a function of sliding cycles (a) and the range of COF of MCS against PUR and Lorica (b)



contribute the difference of MCS/PUR and MCS/Lorica to the variation of skin model materials.

Thus, the influence of normal load on the COF of MCS contacting with various skin models was illustrated in Fig. 38.5. The friction coefficients of both cases investigated systematically decreased with the applied normal load during the friction experiments. It was also showed that it was decreasing rapidly in the lower load form 0.5 to 2 N, followed by relatively constant or stable frictional behaviour. The results can be approximated by a function of the form  $\mu(N) = aN^{-\frac{1}{3}} + b$ , where  $\mu$  denotes the friction coefficient,  $N$  is the normal load and  $a$ ,  $b$  the fitting parameters. The fitting were plotted in Fig. 38.5 (solid line). Then the friction data can be qualitatively explained by the classical two-term model of friction, corresponding to the common view that the adhesive component of skin friction drops with the normal load to the power of  $-1/3$ . Therefore, it can be assumed that the adhesion friction were predominate mechanisms in both cases of MCS against with PUR and Lorica.

A stable friction stage was observed for both cases in Fig. 38.5. It can be assumed that the load dependence is not significant on the higher load (2–8 N). The COF with the normal load of 4 N for MCS/PUR and Lorica were calculated as the mean COF of MCS, which is no dependence on the normal force. In this case, the COF of MCS/PUR and MCS/Lorica are  $0.89 \pm 0.01$  and  $0.34 \pm 0.01$ , respectively. It can be concluded that the COF of MCS/PUR is higher than MCS/Lorica,



**Fig. 38.5** COF as a function of normal load (*dot*) and non-linear fitting (*solid line*). *Black line* (MCS/PUR):  $\mu = 0.15 + 1.21 * N^{-1/3}$ , *Grey line* (MCS/Lorica):  $\mu = 0.02 + 0.51 * N^{-1/3}$

with a factor of 2.6. And the COF of MCS/Lorica is quite close to the value of MCS ( $0.36 \pm 0.04$ ) from in vivo tests in previous study [10], which indicates that the friction coefficient of Lorica is closer to the real human skin.

Combined with Table 38.1, it reveals the trend that rougher materials have lower friction coefficient from the first sight. Due to the rougher the surface, the fewer the contact points, thus the smaller the real contact area. This finding is also consistent with the work of Derler [8], who observed that the smoother skin model surfaces showed higher friction coefficients as a result of an increased contact area. However, there is no qualitatively explanation about the rate of increased real contact area. Furthermore, the roughness of Lorica is around 71 times of PUR, while the COF of PUR is 2.6 times higher, which is nonlinear relationship.

As for elasticity modulus, Lorica is higher than PUR, with a factor of around 2.4, which is in good accordance with the results of COF. Form Hertz contact model and adhesion friction model,  $F = \tau A_r \rightarrow \mu = F/N = \tau A_r/N = \tau \Pi a^2/N = \tau \Pi \left(\frac{3RN}{4E^*}\right)^{4/3} / N \rightarrow \mu \propto E^{*-4/3}$ . So it can be concluded that the difference on the elastic modulus of MCS and PUR deduce the variation of COF under MCS/Lorica and MCS/PUR.

## 38.4 Conclusions

Friction measurements of MCS against with various models in dry conditions have been carried out in the laboratory, to check the differences on the skin models. The skin model Lorica reveals a lower COF, while the COF of PUR is higher, with a factor of 2.6 and Lorica is better to be mechanical skin model candidates for MCS friction testing. The differences on COF between the two models can be attributing to the variation of elastic modulus.

**Acknowledgements** This work was supported by the Fundamental Research Funds for the Central Universities, the National Natural Science Foundation through project (No. 51175076) and the Natural Science Foundation of Shanghai through project (No. 12ZR1400500). This study is also funded by CSC Fellowship awarded to the first author in 2012.

## References

1. Partsch B, Partsch H (2008) Compression stockings for treating venous leg ulcers: measurement of interface pressure under a new ulcer kit. *Phlebology* 23(1):40–46. doi:[10.1258/phleb.2007.007018](https://doi.org/10.1258/phleb.2007.007018)
2. Baussan E, Bueno M, Rossi R, Derler S (2012) Analysis of current running sock structures with regard to blister prevention. *Text Res J*. doi:[10.1177/0040517512461698](https://doi.org/10.1177/0040517512461698)
3. Liu D, Kwok YL, Li Y, Lao TT (2007) Skin pressure profiles and variation with body postural changes beneath medical elastic compression stockings. *Int J Dermatol* 46:10
4. Gitis N, Sivamani R (2004) Tribometry of skin. pp 1–20
5. Bueno MA, Lamy B, Renner M, ViallierRaynard P (1996) Tribological investigation of textile fabrics. *Wear* 195(1/2):192–200
6. Bhushan B, Tang W (2011) Surface, tribological, and mechanical characterization of synthetic skins for tribological applications in cosmetic science. *J Appl Polym Sci* 120(5):2881–2890. doi:[10.1002/app.33340](https://doi.org/10.1002/app.33340)
7. Ke W, Rotaru GM, Hu JY, Ding X, Rossi RM, Derler S (2014) Relationship between the friction and microscopic contact behavior of medical compression stockings at various strains (submitted, 2014)
8. Derler S, Schrade U, Gerhardt L-C (2007) Tribology of human skin and mechanical skin equivalents in contact with textiles. *Wear* 263:1112–1116. doi:[10.1016/j.wear.2006.11.031](https://doi.org/10.1016/j.wear.2006.11.031)
9. Gerhardt L-C, Mattle N, Schrade GU, Spencer ND, Derler S (2008) Study of skin-fabric interactions of relevance to decubitus: friction and contact-pressure measurements. *Skin Res Technol* 14(1):77–88
10. Ke W, Rotaru GM, Hu JY, Ding X, Derler S (2014) Analysis on the friction of medical compression stockings against human skin with in vivo measurements (submitted, 2014)



# Chapter 39

## Study on Aircrew Survival Experiment on Plateau

Xingwei Wang, Lue Deng, Hailiang Zhou, Qin Yao, Changlin Yang, Lixiong Chen, Heqing Liu, Hong Xie and Yongchang Luo

**Abstract Objective** To research new technology of survival and verify the performance of new survival articles on plateau. **Methods** The technology of communications, orientation, life state surveillance, oxygen generator, and sleeping bag were studied, and survival experiment was accomplished on the Tibet plateau by 2 male volunteers. **Results** New technology of communications, orientation, and life state surveillance were developed; the oxygen generator and sleeping bag were improved; and the composing scheme of survival articles was adjusted. Two male subjects accomplished survival experiment successfully which sustained 72 h on the Tibet plateau at 4,742 and 5,237 m altitude. **Conclusion** The new survival technology was effective for communication, orientation, life state surveillance, jury oxygen supply, and cold resistance, and the new composing scheme of survival articles was competent for 72 h survival on plateau all the year except winter.

**Keywords** Aircrew · Survival · Plateau · Survival equipment

### 39.1 Introduction

Aviation lifesaving refers to the whole process when the aircraft is in danger or unable to use, the aircrew escape from the aircraft and alight to the ground (or water), sent out distress signals and survival by using their carried items and ambient conditions until being rescued. Compared with plain, plateau has special features of the geographical environment, such as hypoxia and coldness. Therefore, the plateau aviation lifesaving technology must be suitable for special characteristics of the plateau, so that flight crew can successfully and safely be rescued when in plateau distress. Plateau aviation lifesaving was seldom researched since there were no plateau geographical features in advanced countries.

---

X. Wang (✉) · L. Deng · H. Zhou · Q. Yao · C. Yang · L. Chen · H. Liu · H. Xie · Y. Luo  
Institute of Aviation Medicine, Beijing 100036, China  
e-mail: xingweiwang2013@sina.cn

Qinghai-Tibet Plateau is the world's largest plateau with highest average elevation [1], so that the plateau aviation lifesaving problems must be solved in China. Plateau survival articles are included in present four series [2], but most of them are same with the general survival except of individual items. Aiming at the practical needs of the plateau survival, this paper researched new technology of long-distance communication, location, life state surveillance, and prolonged survival based on existing lifesaving articles and technologies. A total of 72 h wilderness survival experiment had also been completed on Tibet plateau.

## **39.2 Subject and Method**

### **39.2.1 Subject**

Two healthy volunteers were chosen as subjects to simulate aircrews in distress on plateau; they are aged 22 years and 26 years, respectively, 175 and 170 cm in height, 63.4 and 66.1 kg in weight. Before entering the plateau, they took hypoxia preadaptation exercises in low oxygen cabin with constant pressure 3 h per day for consecutive 5 days. After entering the plateau and staying at the station with 3,700 m altitude for about 24 h, they came to the experimental sites.

### **39.2.2 Material**

1. Garment: Both subjects wore unlined leather flight jackets, 2 pairs of unlined leather flying boots, and uniform trousers (wearing underwear according to the actual ambient temperature).
2. Plateau survival articles: survival articles that fit for plateau survival, composed according to new scheme and based on the general survival articles, including three categories 25 kinds of articles for emergency contact, emergency medical care, and survival. The main difference is that the lifeboat is replaced with new plateau sleeping bag, the emergency oxygen source is replaced with the new plateau solid chemical oxygen generator, 280 g flight lifesaving food and no drinking water were changed to 500 g new plateau flight survival food and 1,000 ml water, and the ultrashort wave (USW) survival radio station was replaced by new satellite communicating handset.
3. Survival equipment: 2 JSS-X type parachutes used for both plain and plateau, provided for the two subjects to simulate the actual survival state of the distress aircrews on plateau.

### **39.2.3 Methods**

1. Preparation: After stayed in the station for 24 h at an altitude about 3,700 m, two subjects were transported to experiment preparation sites at an altitude of

5,374 m by vehicles, and after a short break, they had lunch normally. Then, electrodes and physiological signal detection devices were put on to the subjects' bodies, and the physiological parameters of the subjects were gauged and recorded before the experiment.

2. Survival at the first altitude: After preparation, the experiment started and timing began. Every subject carries plateau survival kit and parachute to trek down, reducing the altitude. The first survival camp was selected above 5,000 m altitude, a simple tent was built before dark with the life-saving parachute, by using tools within survival kits such as survival knives etc., and by virtue of the surrounding terrain and environmental conditions. After dark, subjects passed the night with the simple camping conditions by using the new plateau sleeping bags and thermal insulation bags. During this process, they took water as little as possible. If their hypoxia response is severe, the solid chemical oxygen generator can be used to supply oxygen.
3. Survival at the second altitude: After surviving to the next morning in the first survival camp, the subjects packed up camping articles and had small amount of food and water if necessary. Then they continued to reduce the altitude to about 4,700 m with their articles, and selected the second camp to survive. During this process, they might use solid chemical oxygen generators for oxygen supply. They survived there until to 72 h with survival articles and environmental conditions and goods such as sleet, edible wild herbs and wild fruit, etc.

During the overall survival process, the two subjects survived separately and did not help each other, and there was no help from other testing personnel. The satellite communication functions of the handset were randomized tested in the experiment. Testing personnel readily measured the environment parameters such as altitude, barometric pressure, etc., and monitored and recorded the physiological indicators of the two subjects regularly such as blood oxygen, blood pressure and body temperature, etc., and watch over the subjects to observe their state of life. Survival trial lasted for 72 h. If life failure signs of subjects appeared during the process, the experiment should be terminated immediately, and the first aid must be implemented while transporting the subjects to hospital in the fastest way.

### 39.3 Results

Two subjects accomplished 72 h plateau survival experiment consecutively. The actual altitude of the first survival camp is 5,237 m, and the survival time is 18 h from start to the next morning. The actual altitude of the second survival camp is 4,742 m, and the survival time was 54 h. At the end of the experiment, two subjects were mainly normal. The major physiological indexes of subject A are listed in Table 39.1:

**Table 39.1** The main physiological indexes of subject A

Date	Time	Body temperature (°C)	Blood pressure (mm Hg)	Blood oxygen (%)	Pulse rate (times/min)	Altitude
Day 1	12:06	36.4	118/84	86	83	5,328
	18:32	36.9	123/92	85	83	5,237
Day 2	6:40	37.1	135/100	79	82	5,237
	9:15	–	–	83	82	During the fall
	12:25	36.9	115/81	83	124	4,742
	18:00	37.0	133/95	80	106	4,742
Day 3	7:40	36.5	119/88	82	96	4,742
	12:51	36.6	115/84	89	102	4,742
	21:30	36.7	128/93	82	103	4,742
Day 4	0:15	36.6	–	84	89	4,742
	7:00	36.7	–	79	104	4,742
	9:20	36.4	129/101	85	99	4,742
	21:10	36.5	109/79	91	99	3,860

### ***39.3.1 Long-Distance Communication, Location, and Life State Surveillance Technology***

Since the USW radio signal may be easily blocked and the communication distance is limited on plateau, new communication handset technology has been developed. Using satellite communication, the distance or range of SMS and voice call can reach the scope of the signal of satellite and its ground station. The life feature indexes, and the latitude and longitude of the subjects which included in SMS can be manually or automatically sent out. The life state surveillance of the subjects was realized with the wearable physiological information acquisition technology; the indexes of blood oxygen, pulse rate, and forehead temperature were transmitting to the communicating handset through the Bluetooth technology, and then they were sent to rescue control center through the satellite.

During the experiment, the new communication handset accurately completed the locating in 1 min at the second survival camp where there was no mobile phone signal.

### ***39.3.2 Techniques of Prolonging Survival Time***

#### **39.3.2.1 New Plateau Survival Food**

Considering the metabolic characteristics of aircrews in distress and stress under hypoxic and hypobaric condition, a new kind of plateau survival food was developed. Its main content includes:

1. The proportioning of protein, fat, and carbohydrate was adjusted, with protein reduced and the other two increased, in order to reduce the oxygen consumption of food metabolizing.
2. Adding rhodioloside and lycium barbarum polysaccharide extracted from plants, and spirulina and L—carnitine, in order to alleviate the symptoms of hypoxia.
3. Adding trace elements zinc and vitamins to meet the necessary of body under stress.

The new plateau survival food was packed in compress form, with 4 blocks (250 g) in 1 package. It had advantages of security, long-quality guarantee period, long keeping, small volume, high energy, space saving, etc. The actual consumption of 2 subjects in the 72 h experiment is listed in Table 39.2.

#### **39.3.2.2 New Solid Chemical Oxygen Generator**

To meet the emergency oxygen demand of the aircrew in distress on plateau to drop altitude and survival, a new solid chemical oxygen generator was developed. The component of the oxygen gas from the new oxygen generator is listed in Table 39.3.

During the experiment, the 2 subjects dropped altitude on foot from 5,328 to 4,939 m with survival supplies, then sat down statically, and shared 1 oxygen generator to supply them oxygen. The effect of emergency oxygen supply is shown in Table 39.4.

Results showed that 2 subjects used emergency oxygen supply for 13 and 28 min, respectively, and their oxygen saturations of blood oxygen were all above 90 %, which had been raised 8.4 and 43.5 %, respectively. They were equal to the level of the rest station. After using emergency oxygen supply, the 2 subjects continue to drop to the second survival camp at 4,742 m, and the oxygen left in two air bags was 30 L approximately. Experiment results indicated that 1 solid chemical oxygen generator could supply for 2 people simultaneously and was effective in improving hypoxia.

**Table 39.2** The food consumption of 2 subjects in 72 h (g)

Volunteer	24th hour	45th hour	Gross amount
A	30	30	60
B	30	64	94

**Table 39.3** Component of oxygen gas from new oxygen generator

Component	O <sub>2</sub> (%)	CO <sub>2</sub> (ppm)	CO (ppm)	Cl <sub>2</sub> (ppm)	Fiber size (μm)
Content	99.8	400	12	<0.1	Φ40 × 60 μm

**Table 39.4** The effect of emergency oxygen supply (%)

Subject	3,860 m	4,742 m	4,939 m		Using time (min)
			Before	After	
A	90	83	83	90	13
B	89.5	81	69	93	28

### 39.3.2.3 New Plateau Sleeping Bag

A new kind of plateau sleeping bag was developed by using carbon fiber of coffee beans as filler material, instead of the seven holes cotton. The warm performance of the new sleeping bag increased significantly. The inspection result of State Quality Supervision and Inspection Center of Special Protective Clothing showed that the warm value of new sleeping bag with winter flight suits reached 7.23 clo. The sample piece of the new sleeping bag and experiment scene was shown in Fig. 39.1.

During the experiment, 2 subjects could normally sleep by using the new plateau sleeping bag (with the original cooler bag) in the environment of 3 °C and 4,742 m. They did not feel cold except feet cool.

**Fig. 39.1** The new sleeping bag and the experiment scene on plateau

### **39.3.2.4 New Composing Scheme of Survival Articles**

According to the real need of plateau survival, new composing scheme of survival articles was researched and determined with limits of size, volume, and weight. In addition to the changes of radio, oxygen generator, and sleeping bag, the main adjustments were as follows:

Abandoning unnecessary or less important articles in plateau survival: The “shark repellent” and “desalter” were abandoned since there is no sea in Tibet. Increasing indispensable articles: A total of 500 g new plateau flight survival food was allocated instead of 280 g flight survival food, and 1,000 ml drinking water was provided. The plateau survival experiment showed the new composing scheme of survival articles could better meet the needs of plateau survival.

## **39.4 Discussion**

### ***39.4.1 Long-Distance Communication, Location, and Life State Surveillance Technology Research***

The plateau is vast, sparsely populated; persons in distress are hard to find. The communication distance of the survival radio now is 1.8 km; its beacon distance is 100 km while voice communication distance is 70 km at the height of 3 km [1]. As FM signal can easily be blocked by mountain terrain, the effective communication range of radio is very limited on the plateau. Though an improved radio had GPS positioning function, problems of confidentiality and control existed.

The new communication handset located by the Beidou satellite sent SMS and voice calls using our satellite. The communication distance and range were that of the satellite and ground station. The life state parameters and location information of subjects were transmitted via satellite, so the information of subjects could be remote monitor. Because of the coordination problem, some features were not verified in the plateau experiment, but they were normal in the inland experiment base, and would be better on plateau. This technology will effectively solve the problem of long-distance communication, location, and life state monitoring of aircrews in distress on plateau.

### ***39.4.2 Survival Time Prolonging Technology Research***

The main factors affecting the aviation survival on plateau were hypoxia and rescue difficulty [1]. There was a professional flying rescue team in our country [3], and rescue aircraft and ship in Air Forces and Navy [4]. But the rescue activities of vehicles and helicopters were usually affected by the mountain and gully terrain and

the bad weather on plateau. Above the snow line, rescue would become much difficult [5]. These factors make the plateau rescue time much prolonged. Data showed the probability of survivability of wounded aircrews would reduce 80 % after 24 h and that of the aircrews without the injury reduced significantly after 3 days [6]. Persons in distress faced a serious threat in the harsh plateau environment at any moment. Therefore, measures must be taken to prolong the survival time.

#### **39.4.2.1 Research on New Survival Food**

Relevant data show that the reserved energy in a 70 kg person body is about 237,000 kJ, it can supply people to survive 19 days [1]. Therefore, food lack does not constitute a serious threat to life in a short period. But the aircrews in distress on plateau would consume much more energy since the wind, large range of temperature, stress state, and altitude reducing activities. Hunger feeling and fear caused no food will seriously affect the people's will to survive. In this paper, a new kind of plateau survival food was developed, the energy ratio of three kinds of major nutrition was adjusted, and anti-stress function of micronutrients and nutrients was added. It is more suitable for plateau survival needs.

In this experiment, 2 subjects survival for 72 h with only a part of the food and water, which showed that the distribution of food was to meet the demand of 72 h plateau survival.

#### **39.4.2.2 New Solid Chemical Oxygen Generator Technology Research**

The primary factors affecting the plateau survival are plateau reaction induced by hypoxia. The pressure of oxygen at 5,000 m is about half of sea level. One might have a headache, cyanosis, be short of breath, and other symptoms if take physical activities 1. Distress personnel should drop altitude as possible, it will increase the oxygen consumption, and the oxygen reaction will be more serious. Therefore, emergency oxygen supply is necessary to save on plateau survival.

The main principle of the new solid chemical oxygen generator was that producing oxygen by the thermal decomposition reaction of rich oxygen chlorate. By improving the start drug formulation, composing the boundary oxidation agent, reducing temperature sensitivity, and improving thermal insulation measures, the oxygen producing rate was better controlled, and the production of oxygen was increased. This was very important to successful survival on plateau.

In the survival experiment, 1 oxygen generator supplied 2 subjects to drop 500 m vertical altitude on foot, and after that there was certain amount oxygen remained. Thus, 1 oxygen generator will certainly supply 1 people to survival in actual distress.



### 39.4.2.3 New Sleeping Bag Technology Research

Since the larger temperature difference between day and night, cold proof is essential for the survival on plateau except hypoxia. The cold-proof articles were mainly clothing, sleeping bag, and umbrella, of which only sleeping bag can be possibly improved. There exist certain linear relation between the comfortable temperature and thermal value of sleeping bag [7]. The thermal value of present sleeping bag is only about 1.5 clo [8], which is difficult to meet the demand of the plateau survival.

There are limits in packaging, volume, weight, and storage for sleeping bag. Usually, the high performance alpine sleeping bag is filled with eiderdown; its comfortable temperature can reach  $-32\text{ }^{\circ}\text{C}$ . But its warm performance will be greatly reduced once wet, and it can be used only when dry again [9]. At present, it has not been reported that the alpine sleeping bag can meet the requirement of survival articles storage temperature  $+70\text{ }^{\circ}\text{C}$  [10].

In this study, seven holes cotton material currently used was instead with carbon fiber of coffee beans. This kind of material is pure natural, comfortable, easy drying and has high warm value. The experiment results showed that the warm value of the new sleeping bag was increased by using the new filling material. The new sleeping bag can better meet the needs of plateau survival.

### 39.4.2.4 New Composing Scheme of Survival Articles Research

The principle of survival articles composing is life insurance prior and communication chief [1]. The present plateau survival articles are almost the same with the general survival articles, except “Gaoyuankang” drug added, lifeboat replaced by sleeping bag, and some equipped with old solid chemical oxygen generator.

Plateau is windy and drought, water consumption is large in distress. Usually, one person at least lose about 1,500 ml water per day, water loss will be more in plateau environment. When the water loss reached 20 % of body weight, it can cause death. If the dehydration speeds, 15 % can be a fatal [12]. So, the drinking water must be included in survival articles. In this paper, composing scheme of survival articles was adjusted, especially increased 1,000 ml drinking water. The experiment results showed that 2 subjects drank 650 and 950 ml water, respectively, and the amount of food consuming was less than 100 g. This showed the importance of water in survival, also showed that the effect of survival food was really only alleviating hunger so that increasing the survival confidence.

It was forced to instead lifeboat with sleeping bag since the strict limits of package volume and weight. There are a lot of lakes on the plateau, for example, the lake in Tibet Plateau reached more than 2,000 [13]. Aircrews can possibly fall into lake, so the lifeboat is essential also. Therefore, to expand the chair basin volume as far as possible, to integrate articles, and to decrease the volume and weight, so that lifeboat and sleeping bags can also assembled, is an important development direction of solving plateau rescue problem.

Considering the danger in the harsh plateau survival environment, only 2 subjects were chosen. The selection of subjects is in accordance with the pilot physical standard strictly, though their physical condition is not as good as the pilot. They were born and grew in Hu-nan and Jiang-xi province, with no innate hypoxia tolerance. Therefore, the experiment results are convincing.

## 39.5 Conclusions

Aiming at rescue needs in the special plateau environment, this paper developed new technologies of satellite communications, life condition monitoring and emergency oxygen source, and adjusted and determined the composing scheme of survival articles. Two subjects successful completed 72 h of continuous wilderness survival experiment at altitude above 4,700 m. The results showed that the new technologies and solutions for the plateau rescue is suitable and effective.

## References

1. Lu H, Fei Y (2006) Lifesaving science. National Defense Industry Press, Beijing
2. Mao S-J, Kong L (1993) Chinese pilot survival items. *Int Air*, 58–60
3. Gen Yu (2009) Aviation emergency rescue. Aviation Industry Press, Beijing, pp 106–108
4. Chu XinQi (2003) Build of maritime rescue system. *Naval Med* 24(3):245–246
5. Ge Rili (2005) Research review of Chinese Plateau medicine. *J Qinghai Med Coll* 26(1):1–2
6. Breuminger MS (1995) United States combat aircrew survival equipment US. Schiffer Publishing, Atglen, pp 22–24
7. Huang J (2006) Discussion on warm keeping value sleeping bag and a comfortable temperature values. *Ergonomics* 12(2)
8. GJB7008-2010 Specification of flight crew rescue cold sleeping bag
9. Zhao N, Li A, Liu K, Li C-Y, Zhou Q (2012) Study of new multifunctional forest firefighters sleeping bag. *Forest Labour Saf* (04)
10. GJB1460A-2010, Common specification of flight crew survival items [S]
11. Nie X (2009) Research on plateau alpine scene warm sleeping bag and small research trials. *Chin Pers Protective Equip* (4)
12. Sun X (2005) Emergency survival and rescue after landing (water). Fourth Military Medical University Press, Aerospace biodynamic Xi'an, pp 168–172
13. Tibet Autonomous Region Atlas (2010) Planet Map Publishing House, Beijing

# Chapter 40

## The Influence of Transcranial Micro-electric Current Physiological Training on Cerebral Function Under Altitude Hypoxia

Yongsheng Chen and Yongchang Luo

**Abstract Objective** To investigate the effects of transcranial micro-electric current physiological training (TMCPT) on cerebral function (CF) in order to provide technology and methods for maintaining and training CF under altitude hypoxia. **Methods** Forty healthy volunteers served as subjects, who took flight to the altitude and were trained by TMCPT in the condition of altitude hypoxia (3,700 m above sea level). Current intensity of TMCPT was limited within safe physiological range. Subjects were trained twice per day (one in the morning and the other in the afternoon), each for 5 min. Neurobehavioral ability index was separately observed in rush entry phase (first 10 days after entry) and in various resident phases (resided in altitude for 1, 2, and 3 months). Self-evaluating questionnaire and Pittsburgh Sleep Quality Index were used to evaluate sleep quality in different phases. **Results** ① In rush entry phase: digital scan, memory scan, simple visual reaction time, complex visual reaction time, pursuit aiming and consecutive performance were significantly increased at 10 days after TMCPT training ( $t = 1.982-4.412$ ,  $P < 0.05$ ) as compared with those at 1 day. ② Resident phase: compared to neurobehavioral ability index at 1 month, only digital scan, memory scan and simple visual reaction time were significantly increased at 3 months after TMCPT ( $t = 3.744-5.812$ ,  $P < 0.05$ ) as compared with those at 1 month. ③ Sleep quality evaluation: sleep quality indexes had a significant reduction after TMCPT as compared with those in rush entry phase ( $t = 1.833-3.552$ ,  $P < 0.05$ ). **Conclusions** TMCPT can improve CF and sleep

---

Funding: this study was supported by the Key Science and Technology Project of Military Logistics Service during the 12th Five-Year Plan Period, No. AKJ11J005.

---

Y. Chen (✉) · Y. Luo  
Institute of Aviation Medicine, Air Force, Beijing 100142, China  
e-mail: chen Yongsheng65@sina.com

Y. Luo  
e-mail: yongchang\_luo@sina.cn

quality under altitude hypoxia. The  $\beta$ -frequency brain-wave feedback training can be used to promote CF, and  $\alpha$ -frequency brain-wave feedback training can be utilized to improve sleep quality.

**Keywords** Altitude · Hypoxia · Brain · Neurobehavioral manifestations

## 40.1 Introduction

Cerebral function (CF) can be impacted by hypoxia, and some symptoms would appear, such as headache, insomnia, depression and low cognitive ability. Oxygen inhalation or taking drugs for improving oxygen metabolism of brain cells can resist these adverse effects, but these effects are indirect. Transcranial micro-electric current physiological training (TMCPT) is to directly guide microcurrent (strength: microampere;  $\mu\text{V}$ ) into the brain through simulating brain wave with surface electrode on the scalp. TMCPT physically intervenes and regulates central nervous system. This kind of regulatory effect could lessen depression, improve emotional state and elevate cognitive ability [1–13]. This study observed the effects of TMCPT on CFs of persons receiving residential altitude training, and provided technical methods for maintaining residential altitude training.

## 40.2 Subjects and Methods

### 40.2.1 Subjects

A total of 40 healthy, medical fitness volunteers aged 18–40 years with a mean age of  $(28.5 \pm 10.4)$  years were recruited. They did not have a history of nervous system disease or psychiatric history or drug history. In normal time, daily schedule of these volunteers was the same as the army's. Their sleep was regular and normal. They had not been resident in altitude. According to the time of entering the altitude, they were divided into two parts: rush entry (first 10 days after entry) and resident (resided in altitude for over 1 month). The resident phase contained 1, 2 and 3 months.

### 40.2.2 Methods

#### 40.2.2.1 A Device for Cognitive Function Training

A medical electric stimulator (Model BT701; Shanghai Huayi Medical Instruments Co., Ltd., Shanghai, China) was used for TMCPT. This device outputs

unsymmetrical dual-directional continuous pulse wave and simulates brain-wave frequency, including four frequency bands:  $\delta$  frequency band 1–3.8 Hz,  $\theta$  frequency band 4–7.8 Hz,  $\alpha$  frequency band 8–12.8 Hz (slow  $\alpha_1$  frequency band 8–9.8 Hz, fast  $\alpha_2$  frequency band 10–12.8 Hz),  $\beta$  frequency band 14–30 Hz; frequency range of stimulation was 0–40 Hz, continuously adjustable [14–16].

#### 40.2.2.2 Evaluation of Cognitive Function

1. Neurobehavioral evaluation system [17]: in accordance with neurobehavioral core test battery Chinese 3, six items that are strongly associated with flight were selected, including digital scan, memory scan, simple visual reaction time, complex visual reaction time, pursuit aiming and consecutive performance. Neurobehavioral ability index is an evaluation index.
2. Self-assessment of training effect: subjective feeling of volunteers was tested using an own scale, containing pain, tension, anxiety, fear, comfortableness and happiness [5, 6].
3. Evaluation of sleep quality: Pittsburgh Sleep Quality Index was utilized to assess sleep quality after rush entry training, including subjective sleep quality, sleep latency, sleep duration, sleep efficiency, sleep difficulty, using of sleep medicine and dysfunction in day. Each item contains 0, 1, 2 and 3 points; total score ranges from 0 to 21 points. High score indicates poor sleep quality [1].

#### 40.2.2.3 Training Methods

When the brain is in a state of alertness,  $\beta$  frequency band is predominant. When the brain is in a sleeping state,  $\alpha$  frequency band is predominant. According to above-mentioned principle, we simulated  $\beta$  frequency band in day, and simulated  $\alpha$  frequency band at night [16]. Stimulus intensity of microcurrent was extremely weak ( $<1$  mA, in accordance with medical electrical equipment—general requirements for safety [18]). TMCPT was performed in frontal region ( $F_{p1}$ ,  $F_{p2}$ ) and occipital region ( $O_1$ ,  $O_2$ ) with dual-channel electrodes (each channel contains a positive electrode and a negative electrode). The training was carried out at 8:30 a.m. or 22:30 p.m. daily, each time for 5 min. Thus, neurobehavioral ability index and cognitive function were evaluated every day after training. Sleep quality was assessed once after rush entry training.

### 40.2.3 Statistical Treatment

The data were analyzed using SPSS 14.0 software and expressed as mean  $\pm$ SD. Analysis of variance was used for own control and repeated measure.  $t$ -test was applied to compare the difference in different entry phases. A value of  $P < 0.05$  was considered statistically significant.

## 40.3 Results

### 40.3.1 Rush Entry Phase

Neurobehavioral ability index increased with increased entry time in first 10 days after entry in 40 volunteers ( $F = 16.50$ ,  $P = 0.001$ ). As displayed in Table 40.1, compared with 1-day entry, digital scan was significantly higher at 3, 6 and 10 days after entry ( $t = 2.520$ – $3.544$ ,  $P < 0.05$ ); memory scan was significantly higher at 10 days ( $t = 2.350$ ,  $P < 0.05$ ); simple visual reaction time was significantly higher at 4, 6 and 10 days ( $t = 4.142$ – $4.412$ ,  $P < 0.05$ ); complex visual reaction time was significantly higher at 6 and 10 days ( $t = 2.923$ ,  $3.530$ ,  $P < 0.05$ ); pursuit aiming and consecutive performance were significantly higher at 5, 6 and 10 days ( $t = 1.982$ – $2.888$ ,  $P < 0.05$ ).

### 40.3.2 Resident Phase

After TMCPT, significant differences in the six items of neurobehavioral ability index were detectable in 40 volunteers ( $F = 20.10$ ,  $P = 0.003$ ). As exhibited in Table 40.2, compared with 1-month residence, digital scan, memory scan and simple visual reaction time were significantly higher at 3 months after residence ( $t = 3.744$ – $5.812$ ,  $P < 0.05$ ); no significant difference in complex visual reaction time, pursuit aiming and consecutive performance was detected ( $P > 0.05$ ).

### 40.3.3 Evaluation Results of Sleep Quality

During TMCPT, eight volunteers affected a sense of tension, but the remaining did not have discomfortableness. As shown in Table 40.3, compared with rush entry phase, subjective sleep quality, sleep latency, sleep duration, sleep efficiency, sleep difficulty, using of sleep medicine and dysfunction in day, as well as the total score of Pittsburgh Sleep Quality Index were significantly lower in volunteers receiving TMCPT ( $t = 1.833$ – $3.552$ ,  $P < 0.05$ ).

## 40.4 Discussion

TMCPT is accorded with the principle of microcurrent stimulation technique, imports the simulated brain wave into the brain, strengthens cognitive function, promotes sleep and elevates cognitive ability. The device regulates CF status by simulating brain wave of different frequencies. For example, frequency of brain

**Table 40.1** Effect of transcranial micro-electric current physiological training on neurobehavioral ability index of 40 volunteers in altitude rush entry phase( $x \pm s, n = 40$ )

	NAI							
	DS	MS	SVRT	CVRT	PA	CP		
1st day	4.62 ± 0.92	2.23 ± 0.75	14.08 ± 2.34	14.80 ± 3.24	1.84 ± 0.32	0.45 ± 0.07		
2nd day	5.43 ± 0.85	2.11 ± 0.68	15.40 ± 2.44	14.62 ± 3.50	1.85 ± 0.33	0.48 ± 0.06		
3rd day	6.64 ± 0.75 <sup>#</sup>	2.30 ± 0.75	14.95 ± 2.38	15.12 ± 2.89	1.78 ± 0.27	0.46 ± 0.06		
4th day	5.25 ± 0.72	2.43 ± 0.69	19.81 ± 3.89	14.33 ± 3.80	1.85 ± 0.32	0.45 ± 0.07		
5th day	5.13 ± 0.81	2.35 ± 0.77	19.81 ± 3.89	15.25 ± 2.75	1.90 ± 0.25 <sup>#</sup>	0.65 ± 0.06 <sup>#</sup>		
6th day	7.11 ± 0.80 <sup>#</sup>	2.23 ± 0.75	15.05 ± 2.40	17.75 ± 2.82 <sup>#</sup>	1.99 ± 0.31 <sup>#</sup>	0.72 ± 0.05 <sup>#</sup>		
7th day	4.78 ± 0.92	7.20 ± 0.65	20.35 ± 2.87 <sup>#</sup>	14.45 ± 3.60	1.78 ± 0.28	0.50 ± 0.06		
8th day	5.35 ± 0.92	2.35 ± 0.77	14.98 ± 2.12	14.43 ± 2.99	1.78 ± 0.27	0.64 ± 0.07		
9th day	5.51 ± 0.85	2.43 ± 0.88	14.47 ± 3.57	14.25 ± 3.74	1.80 ± 0.35	0.48 ± 0.07		
10th day	6.43 ± 0.91 <sup>#</sup>	5.68 ± 0.80 <sup>#</sup>	23.99 ± 2.83 <sup>#</sup>	18.15 ± 2.89 <sup>#</sup>	1.98 ± 0.33 <sup>#</sup>	0.95 ± 0.06 <sup>#</sup>		
F	9.59	7.75	25.25	24.38	4.93	2.78		
P	0.002	0.012	0.001	0.001	0.045	0.038		

Note as compared with the neurobehavioral ability index on 1st day  
<sup>#</sup>  $t = 1.982-4.412, P < 0.05$

**Table 40.2** Effect of transcranial micro-electric current physiological training on neurobehavioral ability index of 40 volunteers in altitude resident phase( $x \pm s$ ,  $n = 40$ )

NAI	Training time (month)			<i>F</i>	<i>P</i>
	1-month resident	2-month resident	3-month resident		
DS	5.48 ± 1.12	5.30 ± 1.35	8.15 ± 1.31 <sup>#</sup>	9.50	0.012
MS	3.75 ± 1.85	2.59 ± 1.92	5.18 ± 1.87 <sup>#</sup>	6.45	0.044
SVRT	15.64 ± 2.35	15.88 ± 2.40	20.45 ± 2.37 <sup>#</sup>	23.35	0.001
CVRT	14.33 ± 3.85	14.15 ± 3.78	14.31 ± 3.81	5.75	0.078
PA	2.04 ± 0.36	1.89 ± 0.46	2.03 ± 0.37	1.89	0.098
CP	0.78 ± 0.15	0.75 ± 0.14	0.80 ± 0.12	1.65	0.101

Note as compared with the neurobehavioral ability index on 1-month residence

<sup>#</sup>  $t = 3.744-5.812$ ,  $P < 0.05$

**Table 40.3** Comparison on sleep quality of 40 volunteer between rush entry phase and resident phase( $x \pm s$ ,  $n = 40$ )

Pittsburgh sleep quality index item	Stage		<i>t</i>	<i>P</i>
	Rush entry phase	Resident phase		
Subjective sleep quality	1.57 ± 0.61	1.38 ± 0.58 <sup>#</sup>	1.982	0.044
Sleep latency	1.62 ± 0.54	1.12 ± 0.57 <sup>#</sup>	1.865	0.042
Sleep duration	1.48 ± 0.73	1.21 ± 0.51 <sup>#</sup>	1.955	0.031
Sleep efficiency	0.91 ± 0.72	0.55 ± 0.22 <sup>#</sup>	1.833	0.048
Sleep difficulty	1.57 ± 0.64	1.20 ± 0.42 <sup>#</sup>	2.012	0.045
Using of sleep medicine	0.56 ± 0.35	0.43 ± 0.07 <sup>#</sup>	1.991	0.033
Disfunction in day	2.14 ± 0.63	0.84 ± 0.56 <sup>#</sup>	2.544	0.049
Total	9.85 ± 2.97	6.86 ± 1.96 <sup>#</sup>	3.552	0.047

Note as compared with the score of Pittsburgh sleep quality in rush entry phase, <sup>#</sup>  $t = 1.833-3.552$ ,  $P < 0.05$

wave was >13 Hz ( $\beta$  frequency band) during consciousness. Frequency of brain wave was 8–9.8 Hz (spindle wave; slow  $\alpha$  frequency band) or 4–7.8 Hz ( $\theta$  frequency band) and 1–3.8 Hz (slow wave;  $\delta$  frequency band) during sleeping. Electroencephalogram (EEG) bio-feedback training has been applied in the neuropsychic and neuropsychological fields for over 30 years. EEG bio-feedback training is mainly employed to treat anxiety, tension and attention deficient disorder, with a mature technique and affirmative outcomes [10–15]. However, EEG bio-feedback technique has great limitations for the past many years. That is, only one frequency range was focused, such as  $\alpha$  frequency band (8–12.8 Hz), because this frequency band is associated with psychological relaxation training. The relaxation training aims to keep attention and to concentrate one's energy, but seldom focuses on elevating cognitive ability. The relaxation training through  $\alpha$  frequency band can elevate cognitive ability, but it is indirect. Because EEG  $\alpha$  wave power can be strengthened during relaxation (or amplitude increase), but  $\alpha$  wave



will change into  $\theta$  wave or  $\delta$  wave during lassitude or hypnotism, i.e., from 8–12.8 to 4–7.8 Hz or 1–3.8 Hz. This was contrary to feedback training in the waking state when  $\beta$  frequency band was utilized to elevate cognitive ability.  $B$  frequency band (14–30 Hz), as a basis for the brain to keep alertness, is associated with cognitive activity. A previous study suggested that when operation activity was performed, cognitive activity in the projection areas of limbs (dominant hand), which was associated with the operation activity, would increase. The more complicated the operation activity, the more obvious the activity in the region related to cognitive function was. EEG power spectrum analysis is characterized by an increase in  $\beta$  frequency power [3–5, 12]. This study exactly simulated human brain-wave  $\beta$  frequency, and performed regular stimulation training in a special region of the brain using dual-directional alternating pulse current to elevate cognitive ability. Compared with previous similar studies, the present study extended the range of stimulation frequency, simulated  $\beta$  frequency band, besides  $\alpha$  frequency band, and utilized TMCPT to elevate or keep cognitive ability in altitude.

#### ***40.4.1 Feedback Training of Brainwave $\beta$ Frequency Band***

Rush entry phase training results demonstrated that the time course of training of brainwave  $\beta$  frequency band was 5 min. In the initial stage, memory scan was not apparently elevated, but 10-day regular training noticeably increased the six items of cognitive ability related to flight performance. During the 10-day regular training, cognitive ability did not elevate simultaneously. For example, digital scan and simple visual reaction time elevated at 3 and 4 days, respectively, but pursuit aiming and consecutive performance elevated at 5 days. At 3 days after training, digital scan was elevated prior to pursuit aiming and consecutive performance, which was possibly because frontal lobe was first influenced by electric pulse stimulation. Numerous previous studies [1–14] confirmed that cerebral frontal lobe was associated with calculation, retrieval and logical thinking. Regular electric pulse stimulation on the frontal region could activate associated brain areas, increase regional blood flow, enhance excitability of nervous tissues and intensify neurological function related to above-described brain areas. Under regular training program, continuous training for 1 week (on the 6th day) could show evident training effect.

#### ***40.4.2 Promoting Effect of Feedback Training of Brainwave $\alpha$ Frequency Band on Sleep***

Sleep medicine study suggested that  $\alpha$  wave frequency became slow, and gradually became slow wave ( $\theta$  frequency band, 4–7.8 Hz) when people felt sleepy or in

sleep state, and then entered more slow rhythm ( $\delta$  frequency band, 1–3.8 Hz) in a state of deep sleep. This study simulated  $\alpha$  frequency band in the training for 5 min every day in healthy volunteers, adjusted the sleep center of the brain using TMCPT, and improved sleep quality. Previous studies confirmed that low-frequency alternating electric field acting on particular brain areas adjusted the excitatory and inhibitory processes of cerebral cortex by affecting bioelectric activity of nerve cells in the corresponding brain areas, and indirectly improved cognitive function and sleep by affecting cerebral blood flow [12–14, 19].

At present, low-frequency alternating electric field probably widely acts on cell membrane, affects ion permeability of cell membrane, alters cell microenvironment, influences cell metabolic activity and induces an alternation in nerve cell excitability. These results indicated that TMCPT had regulatory effects on sleep, and provided a manner for studying the biological effects of TMCPT on cognitive function.

#### ***40.4.3 TMCPT and Maintenance of Cognitive Ability***

Both in rush entry phase and resident phase, TMCPT results showed that the maintenance or elevation of neurobehavioral ability index did not increase with prolonged training time. A decrease or non-maintenance during training might be associated with the plasticity of cognitive function. Nerve cells have memory function and associate with ion channel protein on cell membrane. Regular TMCPT possibly alters the structure of these memory proteins and cognitive ability. However, this change is not stable. If the training is interrupted, proteins will easily suffer from allosteric property, i.e., cognitive ability cannot maintain original levels, and decreases [8–10, 16–20]. In this study, digital scan, memory scan, simple visual reaction time, complex visual reaction time, pursuit aiming and consecutive performance were significantly elevated after 10 days of rush entry training. Nevertheless, complex visual reaction time, pursuit aiming and consecutive performance reduced during non-regular continuous training in resident phase, suggesting that continuous training is very important.

#### ***40.4.4 Significance of Cognitive Training for Flight in Altitude***

Altitude hypoxia is a key reason for the decrease in cognitive function. Altitude medicine study showed that mild cognitive dysfunction could be observed after over half a year of living in altitude, such as short-time memory ability decrease, bad response and wrong fine manipulation [1]. Flight is a high-load mental and physical abilities which is characterized by high acceleration, high cognitive loading and high angular acceleration. The ever-increasing battle plane's

performance and the occurrence of advanced complicated electrical cabin have strict requirements for cognitive function of a pilot in altitude. Therefore, the training for cognitive function of a pilot in altitude is necessary to ensure advanced weapon to exert its maximum efficacy. Oxygen supply device is well provided for a pilot, but 24-h oxygen supply is impractical. The reduction in cognitive function under hypoxia cannot be avoided in altitude. Thus, cognitive function intervention and training are effective and practical under current conditions.

## References

1. Chen Y, Wang S (2012) The effects of altitude hypoxia on sleep and cerebral function. *Med Air Force* 8(3):150–158
2. Sampaio LA, Fraguas R, Lotufo PA et al (2012) A systematic review of non-invasive brain stimulation therapies and cardiovascular risk: implications for the treatment of major depressive disorder. *Front Psychiatry* 3(1):87–90
3. Motohashi N, Yamaguchi M, Fujii T et al (2013) Mood and cognitive function following repeated transcranial direct current stimulation in healthy volunteers: a preliminary report. *Neurosci Res* 77(1/2):64–69
4. Miranda PC (2013) Physics of effects of transcranial brain stimulation. *Handb Clin Neuro* 116:353–366
5. Stumbrys T, Erlacher D, Schredl M (2013) Testing the involvement of the prefrontal cortex in lucid dreaming: a tDCS study. *Conscious Cogn* 22(4):1214–1222
6. Kaminski E, Hoff M, Sehm B et al (2013) Effect of transcranial direct current stimulation (tDCS) during complex whole body motor skill learning. *Neurosci Lett* 552:76–80
7. Palm U, Fintescu Z, Obermeier M et al (2013) Serum levels of brain derived neurotrophic factor are unchanged after transcranial direct current stimulation in treatment resistant depression. *J Affect Disord* 150(2):659–663
8. Alonzo A, Chan G, Martin D et al (2013) Transcranial direct current stimulation (tDCS) for depression: analysis of response using a three factor structure of the Montgomery asberg depression rating scale. *J Affect Disord* 150(1):91–95
9. Hoy KE, Emonson MR, Arnold SL et al (2013) Testing the limits: Investigating the effect of tDCS dose on working memory enhancement in healthy controls. *Neuropsychologia* 51(9):1777–1784
10. Brunoni AR, Ferrucci R, Bortolomasi M et al (2013) Interactions between transcranial direct current stimulation (tDCS) and pharmacological interventions in the major depressive episode: findings from a naturalistic study. *Eur Psychiatry* 28(6):356–361
11. Javadi AH, Cheng P (2013) Transcranial direct current stimulation (tDCS) enhances reconsolidation of longterm memory. *Brain Stimul* 6(4):668–674
12. Hauser TU, Rotzer S, Grabner RH et al (2013) Enhancing performance in numerical magnitude processing and mental arithmetic using transcranial direct current stimulation (tDCS). *Front Hum Neurosci* 7:244
13. Lefebvre S, Laloux P, Peeters A et al (2013) Dualt DCS enhances online motor skill learning and longterm retention in chronic stroke patients. *Front Hum Neurosci* 6:343
14. Herrmann CS, Rach S, Neuling T et al (2013) Transcranial alternating current stimulation: a review of the underlying mechanisms and modulation of cognitive processes. *Front Hum Neurosci* 7:279
15. Pi X, Lu R, Shen Y (2005) Development of pulse therapeutic apparatus with biphasic constant current and measured electrode impedance. *J Chin Med Equip* 26(9):11–15

16. Yao D (2003) The electronic theory and method for brain detection. Scientific Press, Beijing, pp 1–200
17. Chen Y, Jia H, Deng X et al (2011) Application of neurobehavioral evaluation system for the identification of pilot's cerebral function. *Chin J Aerospace Med* 22(1):22–25
18. YY 0505-2005/IEC60601-1-2 General safety requirements of medical instrument (2001) Medical Industrial Standard of People's Republic of China
19. Zaghi S, Acar M, Hultgren B et al (2010) Noninvasive brain stimulation with low intensity electrical currents: putative mechanisms of action for direct and alternating current stimulation. *Neuroscientist* 16(3):285–307
20. Kuo HI, Bikson M, Datta A et al (2013) Comparing cortical plasticity induced by conventional and high definition  $4 \times 1$  ring tDCS: a neurophysiological study. *Brain Stimul* 6(4):644–648

**Part VI**  
**Research on the Machine-Environment**  
**Relationship**

# Chapter 41

## Simulation of Flight Dynamics for Helicopter Icing

Ruimin Zhang, Junbo Zhao and Jingang Dong

**Abstract** This allows unregistered users to read the abstract as a teaser for the complete chapter. The formulas for calculating the variation of aerodynamic coefficient of iced blade airfoil were introduced according to rotor icing test data from NASA and the formulas for aerodynamic force and moment of rotor icing were deduced. Further, the model of flight dynamics for helicopter icing was built. Icing effect on trim characteristics and stability of certain single-rotor helicopter in hover and forward speed was studied. The results show that whether in hover or forward flight, when the helicopter iced, the amount of the collective control, the longitudinal control, and the lateral control of the rotor, the tail rotor collective control as well as the roll angle increases, while the pitch angle decreases; the longitudinal long-period and short-period mode goes more stable, and the same as the lateral helical mode, while the roll mode and Dutch roll mode go more unstable.

**Keywords** Helicopter · Icing · Flight dynamics · Rotor · Trim · Stability

### 41.1 Introduction

A helicopter is a special vehicle that relies on a rotor to control the horizontal and vertical motion. When flying at a certain height and through the clouds, it is likely to encounter icing. Icing not only affects the aerodynamic performance of the rotor, but also destroys the balance of the helicopter, which makes its flight quality level decrease and also a serious threat to flight safety [1, 2].

Research work about helicopter icing began early in the 1980. A large number of icing test data of blade airfoil were analyzed and summarized by Flemming

---

R. Zhang (✉) · J. Zhao · J. Dong  
China Academy of Aerospace Aerodynamics, Beijing 100074, China  
e-mail: footballguy1980@126.com

et al. [3, 4]. Thus, the empirical formulas for calculating the aerodynamic coefficient increment of the icing blade airfoil cross section were given. The ice molds were attached to the radial position to simulate helicopter icing flight tests by Korkan et al., and so the hovering and forward flight performance data were obtained. A modular approach, trajectory tracking, and 3D imaging method were used by Gasting et al. [5] to get rotor icing data of UH-1H helicopter hovering in the artificial clouds. Numerical simulation of the helicopter icing was developed by Baruzzi et al. [6], and the helicopter flight performance under icing conditions was assessed. Helicopter icing and anti-icing tests were conducted by Didier et al. [7] in ONERA wind tunnel. All these studies focused on the blade airfoil icing test, rotor icing performance and numerical simulation, wind tunnel test and flight test, etc., but not related to flight dynamics of helicopter icing. In recent years, as the demand for the flight around the clock raises, the issue of helicopter icing was taken more attention home and abroad. A lot of work about helicopter icing has also been done by researchers in our country. Droplet impact characteristics about a helicopter rotor were studied by He et al. [8]. Numerical simulation of helicopter rotor blade icing and flight performance analysis and calculation of equilibrium properties of tandem in icing conditions were carried out. According to NASA wind tunnel test data of rotor icing, the formulas of aerodynamic coefficients about rotor icing were deduced and the flight dynamics model of helicopter icing was established. The trim and stability of a modern helicopter in hover and forward state under icing conditions were studied.

## 41.2 Flight Dynamics Model of Helicopter Icing

### 41.2.1 Airfoil Aerodynamic Increment of Icing Blade

#### 41.2.1.1 Lift Coefficient Variation

According to NRC wind tunnel data, the lift coefficient variation is the function of modified inertia parameters, liquid water content, icing time, angle of attack, wing chord length, airfoil thickness, and temperature [3, 4]. The formula is as follow:

$$\Delta C_l = \left[ -0.01335 K_0 \frac{t}{c} (\alpha + 2 + K_{L1} 0.00555 (\alpha - 6)^2) K_L \right] W \left( \frac{c}{0.1524} \right)^{0.2} \tau_c / \left( \frac{c}{0.1524} \right)^{1.2} \quad (41.1)$$

$K_L$  and  $K_{L1}$  are the function of static temperature  $T_s$  and the average angle of attack  $\alpha$ ;  $K_0$  is the modified inertia parameter;  $t/c$  is the ratio of airfoil thickness to chord;  $\tau_c$  is the corrected icing time;  $W$  is liquid water content;  $c$  is airfoil chord.

### 41.2.1.2 Drag Coefficient Variation

According to NRC wind tunnel test data, the drag coefficient variation is the function about the local flow velocity, the density of ice, the collective rate, liquid water content, ice time, angle of attack, wing chord length, thickness, roughness, and temperature [3, 4]. The formula is as follow:

$$\Delta C_d = \left[ 0.158 \ln \frac{k}{c} + 175 \frac{V}{\rho_I c} EW \tau_c + 1.70 \right] \left[ \frac{\alpha + 6}{10} \right] \times \left[ 1 - 8 \Delta C'_d \frac{V_{\text{HELO}}}{278} \right] \times \Delta C_{d_{\text{no ice}}} \quad (41.2)$$

$k/c$  is the ratio of the roughness height to the chord length;  $V$  is the local flow velocity;  $\rho_I$  is density of ice;  $E$  is the total collection rate; As  $V_{\text{HELO}} = 0$ ,  $\Delta C_d = \Delta C'_d$ ;  $V_{\text{HELO}}$  is the flight speed in forward; and  $\Delta C_{d_{\text{no ice}}}$  is net airfoil drag.

### 41.2.2 Aerodynamic Forces and Moments of Icing Rotor

The formula of the variation of rotor thrust, lateral force, and torque coefficients are deduced based on the theory of helicopter blade element, which are as follows:

$$\Delta C_T = \sigma/4\pi \int_0^{2\pi} \int_0^1 \bar{u}_T^2 \Delta C_L d\bar{r} d\psi \quad (41.3)$$

$$\Delta C_Y = -\sigma/4\pi \int_0^{2\pi} \int_0^1 ((\bar{u}_T^2 \Delta C_D - \bar{u}_T \bar{u}_P \Delta C_L) \cos \psi - \bar{u}_T^2 \Delta C_L \beta \sin \psi) d\bar{r} d\psi \quad (41.4)$$

$$\Delta C_H = \sigma/4\pi \int_0^{2\pi} \int_0^1 ((\bar{u}_T^2 \Delta C_D - \bar{u}_T \bar{u}_P \Delta C_L) \sin \psi - \bar{u}_T^2 \Delta C_L \beta \cos \psi) d\bar{r} d\psi \quad (41.5)$$

$$\Delta C_Q = \sigma/4\pi \int_0^{2\pi} \int_0^1 (\bar{u}_T^2 \Delta C_D - \bar{u}_T \bar{u}_P \Delta C_L) \bar{r} d\bar{r} d\psi \quad (41.6)$$

$\bar{u}_T$  and  $\bar{u}_P$  are the tangential and vertical dimensionless velocity of blade airfoil plane;  $\sigma$  is the rotor solidity;  $\bar{r}$  is the dimensionless radial position of the blade;



$\psi$  and  $\beta$  is azimuth and angle of the blade;  $\Delta C_L$  and  $\Delta C_D$  the lift and drag coefficient variation of icing blade.

The pulling force, lateral force, and torque coefficients were as follows:

$$C'_T = C_T + \Delta C_T \tag{41.7}$$

$$C'_Y = C_Y + \Delta C_Y \tag{41.8}$$

$$C'_H = C_H + \Delta C_H \tag{41.9}$$

$$C'_Q = C_Q + \Delta C_Q \tag{41.10}$$

$C'_T$ ,  $C'_Y$ ,  $C'_H$  and  $C'_Q$  are, respectively, the pulling force, lateral force, the aft-force, and torque coefficients.

### 41.2.3 Aerodynamic Forces and Moments of Icing Rotor

The formulas (41.7–41.10) were induced into the class flight dynamic equations of the helicopter [9, 10], so the flight dynamic model of helicopter icing was established. The formulas are as follows:

$$(DE - A_s)x = B_s U \tag{41.11}$$

and

$$x = [\Delta V_x, \Delta V_y, \Delta V_z, \Delta \omega_x, \Delta \omega_y, \Delta \omega_z, \Delta \gamma_x, \Delta \phi_y, \Delta \theta_z]^T \tag{41.12}$$

$E$  is  $9 \times 9$  unit matrix;  $A_s$ ,  $B_s$  is the coefficient matrix.

## 41.3 Calculation and Analysis

The effect of icing on trim and stability of a single-rotor helicopter in hover and forward was studied. The icing conditions are shown in Table 41.1.

**Table 41.1** The icing conditions

Icing parameter	Temperature T/°C	LWC L/g/m <sup>3</sup>	MWD D/μm	Icing time T/s
Value	-28	0.94E-03	30.0E-06	60

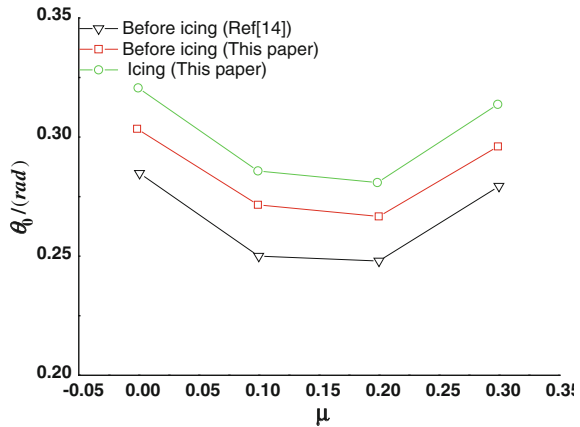
### 41.3.1 Icing Effect on Helicopter Trim

The variation of helicopter trim parameter before and after icing is given in Figs. 41.1, 41.2, 41.3, 41.4, 41.5, 41.6. As can be seen, the results in this paper are very close to those from Ref. [11]. It shows that the flight dynamic model of helicopter icing is reasonable and correct. Otherwise, whether in hover or forward, the collective, the longitudinal and lateral cyclic of rotor, the collective of tail rotor, and the roll angle all increase, while the pitch angle decreases.

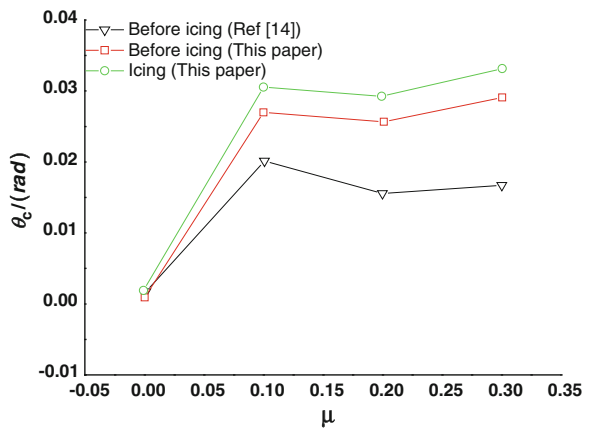
### 41.3.2 Icing Effect on Helicopter Stability

The coupling stability roots before and after helicopter icing are given in Table 41.2. As can be seen, icing has little effect on longitudinal model

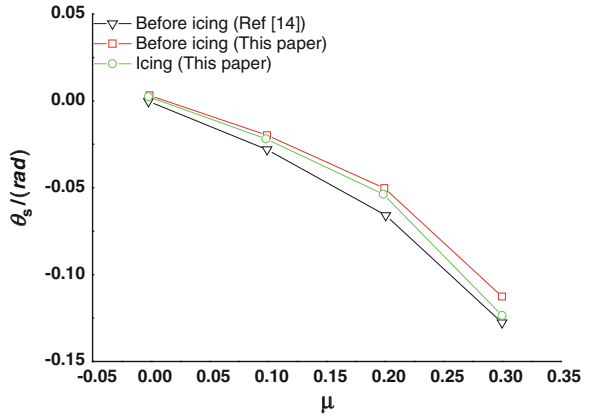
**Fig. 41.1** Icing effect on rotor collective  $\theta_0$



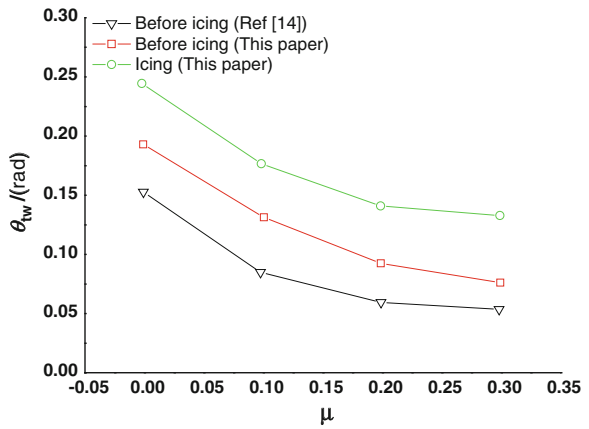
**Fig. 41.2** Icing effect on longitudinal cyclic  $\theta_c$



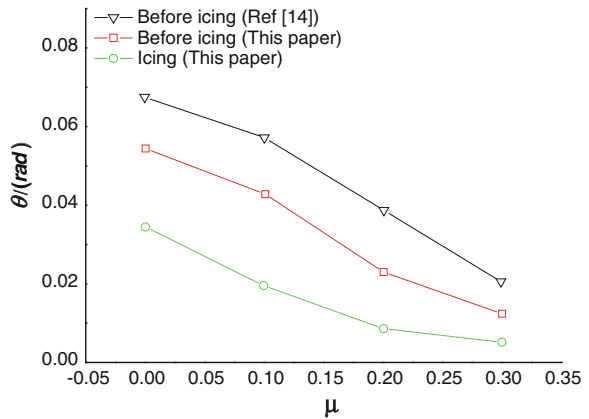
**Fig. 41.3** Icing effect on lateral cyclic  $\theta_s$



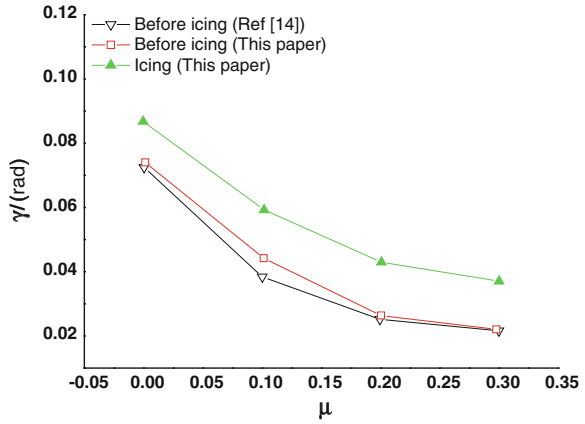
**Fig. 41.4** Icing effect on tail rotor collective  $\theta_{tw}$



**Fig. 41.5** Icing effect on pitch angle  $\theta$



**Fig. 41.6** Icing effect on roll angle  $\gamma$



**Table 41.2** Stability roots before and after icing

	Results before icing	Ref. [12]
$\mu$	0.2	0.2
Longitudinal	$0.0097 + 0.2287i$	$0.01717 + 0.2127i$
	$0.0097 - 0.2287i$	$0.01717 - 0.2127i$
	$-0.5494 + 2.0955i$	$-0.1292 + 2.03i$
	$-0.5494 - 2.0955i$	$-0.1292 - 2.03i$
Lateral and yaw	$-0.3624 + 2.4645i$	$-0.6042 + 2.49i$
	$-0.3624 - 2.4645i$	$-0.6042 - 2.49i$
	$-0.1967$	$-0.3313$
	$-1.0447$	$-0.7414$
	$0$	$0$
	Results after icing	
Longitudinal	$-0.0048 + 0.2403i$	
	$-0.0048 - 0.2403i$	
	$-0.5384 + 2.1390i$	
	$-0.5384 - 2.1390i$	
Lateral and yaw	$-0.3695 + 2.4476i$	
	$-0.3695 - 2.4476i$	
	$-0.2200$	
	$-0.9923$	
	$0$	

characteristics. Compared with the united helicopter, the time of long period and short period both decrease, which means that the mode changes more stable but less obvious; the spiral mode gets more stable, while both the roll and Dutch roll mode change more unstable.

## 41.4 Results

The formulas of rotor aerodynamic forces and moments after icing were deduced based on NRC wind tunnel data. And the nonlinear dynamic equations of helicopter icing were established. Icing effect on the trim and stability a single-rotor helicopter in hover and forward was studied. The results show that flight dynamic model of helicopter icing in this paper is reasonable and correct, which makes a solid basis for research on the handling and flying qualities of helicopter icing.

## References

1. Fu J (1999) Study on helicopter anti-icing. Flight dynamics
2. Wang Z (2001) Helicopter anti-icing problem. Helicopter technology
3. Flemming RJ, Lednicer DA (1983) High speed ice accretion on rotorcraft airfoils. In: Proceedings of 39th annual forum of the American Helicopter Society
4. Flemming RJ, Lednicer DA (1985) Correlation of airfoil icing relationships with two-dimensional model and full scale rotorcraft icing test data
5. Gastinger DC (1983) FAA rotorcraft icing regulations and directions. Vertiflite 29:26–30
6. Baruzzi G, Tran P, Habashi WG, Akel I, Balage S (2004) FENSAP-ICE progress towards a rotorcraft, AIAA 2003-0024
7. Didier PG, Joseph JC, Luc SB (1985) Overview of icing research at ONERA, AIAA-85-0335
8. He Z, Chang S, Yuan X (2002) Rotor-water impact characteristics of helicopter in hover. Aeronaut J
9. Gao Z, Chen R (2003) The helicopter flight dynamics, Peking
10. Cao Y (2005) The helicopter flight dynamics, Peking
11. Xu X, Lin H, Xu X (1988) Research on trim and stability of “dolphin” helicopter. The flight dynamics
12. Chen R, Xu X (1990) Helicopter response to the discrete gust. NUAU J

# Chapter 42

## The Ergonomics Application Research on Differences Between Adaptive Cruise Control System and Drivers

Yuru Gao, Yang Cao and Sen Zhao

**Abstract** Adaptive cruise control (ACC) is an important part of intelligent transportation systems (ITS), and the ergonomics between driver and vehicle is changed. This article researches on the ergonomics between ACC and drivers. A series of vehicle road test is organized in Chinese urban driving conditions. The vehicle data, road data, and the drivers' behavior data are analyzed during the researches. Drivers are interviewed on their feelings when they are applying the ACC system. At last, it shows the differences in behavior between the ACC system and drivers under several working conditions.

**Keywords** Adaptive cruise control · Intelligent transportation · Differences

### 42.1 Introduction

Adaptive cruise control (ACC) is composed of variant vehicle sensors and controllers. It can realize the accelerating and braking of automatic control, control the vehicle speed and vehicle distance between vehicles and front cars, give full play the roles of reducing the driving load, and improve the vehicle safety performance. It is the important constituent part of intelligent transportation systems (ITS) [1, 2]. Considering that ACC masters the longitudinal control right of partial vehicles while working, the longitudinal control right of vehicles is handed over between ACC system and drivers. Thus, it is vital important to research the difference between the systemic behavior and driving actions under the typical working conditions.

---

Y. Gao (✉)

College of Engineering, China Agricultural University, Beijing, China  
e-mail: gaoyuru1612@163.com

Y. Gao · Y. Cao · S. Zhao  
CH Auto Technology Corporation Ltd., Beijing, China

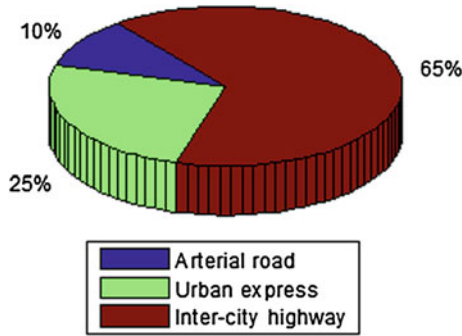
The current ACC development focuses on systemic control, but neglecting the human-machine interacting functions of ACC system to the drivers, causing that drivers recover artificial driving mode while quitting ACC system [3] in the case that the difference exists between driver's expectation and systemic action. Larsson et al., from Lander University, Sydney, has made investigation on ACC users. The conclusion obtained is that the longer the driver drives the car, the more acquainted the driver would become to the ACC system limitations. Among the drivers driving some car for over 10 months, about 80 % of the drivers think that ACC system has limitations [4]. Larsson's investigation makes tentative exploration for human-machine project application effect after ACC enters into the market. Neville A. Stanton et al., from Brunel University, Britain, evaluated ACC by contrasting the drivers' driving ACC system work within the driving simulators or vehicle information and drivers' status of manual driving operation. Evaluating ACC from the psychological perspective, the influence of ACC system on drivers makes drivers absence of manipulation, reduction of sense of trust, and lowering of vigilance, but the driving load and driving pressure of the drivers are lowered with it [5].

Presently, China's vehicle industry develops quickly. Numerous enterprises equip ACC on the medium- and high-end vehicles. Drivers require to synthesize environmental information of roads and the vehicle status under ACC and control the vehicle acceleration, braking or route changing traveling intermittently [6, 7]. This paper would analyze the objective data of vehicles, environment, and operation action of drivers by organizing practical vehicle testing, investigate drivers driving using feelings on ACC, and study the typical working conditions with difference between ACC and drivers, and the time headway while braking quits the system.

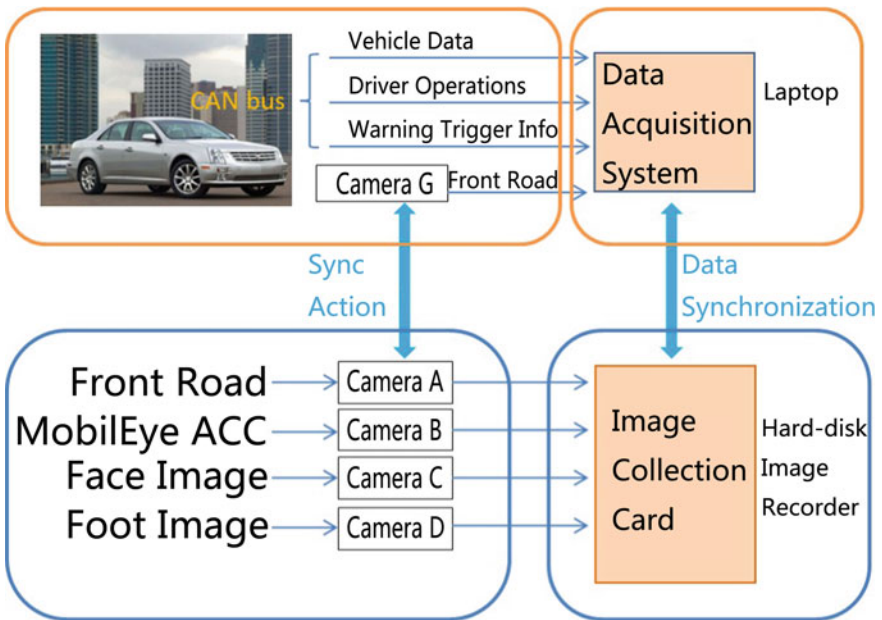
## 42.2 Testing Method

Testing environment information has significant influence on the human-machine interactive features of ACC system and drivers. The related case study shows that the testing conditions of vehicle application characteristics are classified as driving simulator testing, scenario testing, and practical vehicle and road testing [8, 9]. This study adopts practical vehicle and road testing [10, 11] in order to get the information of human-machine interactive features of ACC system and drivers. The recruiting conditions of drivers are the drivers with over two-year driving experience and driving a car once a week at least. The testing route design includes the urban main road, urban expressway road, and intercity highway. According to the application status that ACC system is more ' highways in this testing routes reaches 65 %, city expressway 25 %, and city main trunk 10 % (Fig. 42.1).

The research on the human-machine interaction performance between self-adaptive cruise system and drivers needs to collect environmental information,



**Fig. 42.1** Percentage of road type. The road type including arterial road, urban express road, and inter-city highway



**Fig. 42.2** System configuration for data acquisition platform. The platform consists of CAN data and image data. The data can be synchronized by cameras A and G which record the same front road image

vehicle information, and drivers’ operating information. This test erects the platform of self-adaptive cruise system data, including the test car of self-adaptive cruise system, image sensor, image capture card, and hard disk video. The relationship block diagram of sensor information collection refers to Fig. 42.2.



## 42.3 Testing Results and Analysis

With a view to studying the human–machine interaction performance between cruise system and drivers, it is required to make analysis and comparison in variant aspects of human, machine, and environment. This section analyzes the main points of the working speed of ACC system, typical working conditions of drivers' quitting system, and time headway of drivers' quitting braking system.

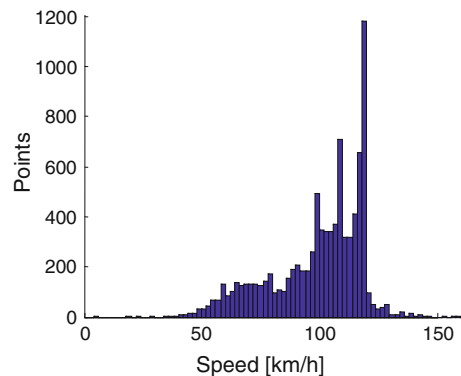
### 42.3.1 Working Speed of Adaptive Cruise Control System

There are over 51 groups of tests. The drivers effectively use 589 adaptive cruise systems. The system using time under all speed is illustrated in Fig. 42.3. The systemic principle of ACC system can be stimulated at the speed of over 40 km/h. The highest speed while cruising is 120 km/h. The speed distribution figure shows that the systemic working time starts to increase from 50 km/h. When principally using, the speed scope falls between 100 and 120 km/h. Thus, this system shall be used for higher speed. By calculating the ACC system, the average speed of vehicles is 97.8 km/h, demonstrating the conclusion. The drivers can improve the car speed by accelerating the auxiliary accelerator pedal. Thus, the car speed would be more than 120 km/h under the working conditions of overtaking.

### 42.3.2 The Typical Working Conditions While Drivers' Braking Quits the System

The subjective investigation questionnaire aiming to the drivers shows that 74.5 % of drivers are very satisfied or very satisfied on ACC system and 25.5 % of drivers are very unsatisfied or very unsatisfied on the system. Research on the working

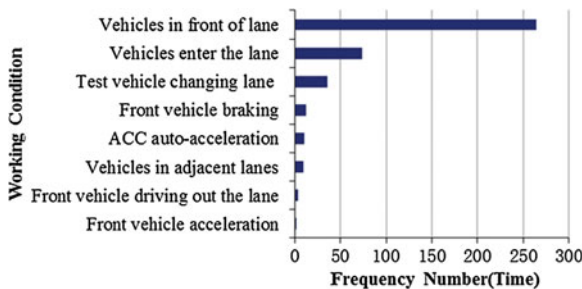
**Fig. 42.3** The test vehicle speed distribution under adaptive cruise control system



conditions of ACC system, especially the working conditions of drivers' braking quitting, has very important meaning to the difference between the ACC system and the behavior characteristics among drivers. There are four quitting ways of ACC system: drivers' quitting from human-machine interacting interface through multi-functional steering wheel, drivers' treading brake pedal, systemic automatic quit when drivers tread the acceleration pedals and speed exceeds 0.25 g, and quitting when speed lower than 32 km/h. According to the literary [8] and practical car testing data, when the vehicle operating trajectory, speed, and drivers' psychological expectation of system control under complex working conditions are different, the drivers would tread the braking pedal and quit ACC system.

According to the different testing data statistics, 499 times of drivers' quitting from system is caused by treading braking pedal, accounting for 84.7 % of the total testing times. However, the highway of the testing road line is arranged with the facilities like ramp and highway toll gates. The places of the above facilities require the drivers reducing speed or parking. Thus, this type of conditions shall be ruled out while analyzing the difference between the system and drivers' behavior characteristics. There are 58 times of vehicle entering into toll gate area in the testing process; vehicles decelerate and quit by drivers' treading petals. There are 30 times of vehicle entering into toll gate area in the testing process; vehicles decelerate and quit by drivers' treading petals. Through verification, the rest 411 times of experience are the working conditions of drivers' quitting system caused by system behavior characteristics and drivers' behavior characteristics.

Considering that the difference between adaptive cruise system behavioral characteristics and drivers' behavioral characteristics is the key point during the human-machine interacting process, this papers makes the synthetic analysis on the specific reasons causing the drivers to quit the system. As shown in Fig. 42.4, the most dominant reason drivers quit ACC by braking is that there are vehicles driving at the place ahead, 264 times totally, accounting for 64.2 % of braking quit. The drivers' braking quit of ACC due to other vehicles switching into the lanes amounts to 74 times, accounting for 18.0 %. The drivers' braking quit of ACC due to test car changing lines amounts to 36 times, accounting for 8.6 %.



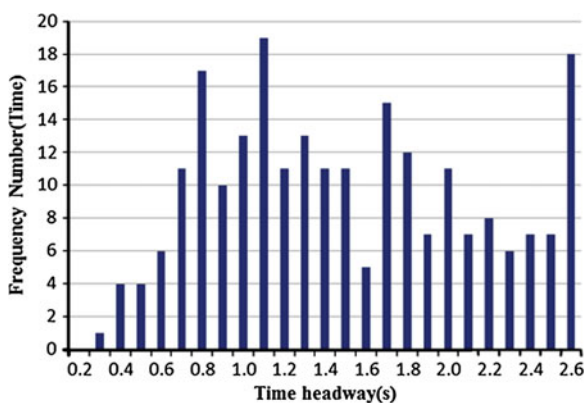
**Fig. 42.4** The working condition's frequency number when drivers are braking and quitting the adaptive cruise control system. The main cause is that there are other vehicles in front of lane (64.2 %), and the second cause is that there are other vehicles entering the lane

Other working conditions of quitting totals 37 times, accounting for 9.0 %, including front car braking, ACC automatic accelerating, lateral lane vehicles, front vehicles switching out of this lane, and front car accelerating.

### 42.3.3 The Time Headway While Drivers' Braking Quits the System

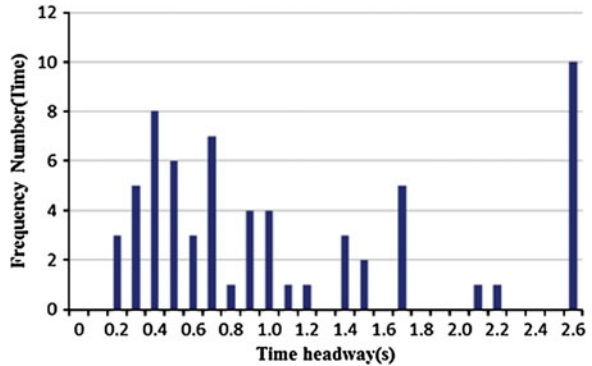
Time headway represents the time interval between the two vehicle head as the important parameters of self-adaptive cruise system judging working status; the distribution of time headway is not only the foundation of environmental adaptive research of ACC [12], but also the foundation of environmental risk consciousness research.

The difference between self-adaptive cruise system and drivers mainly manifests as this current car going straightly under self-adaptive cruise system with other vehicles in the front of the lane. Drivers initiatively tread braking pedal to lower the car speed in order to avoid the bumping of testing car and front car rear-end bumping under the self-adaptive cruise system control. Under these working conditions, the time headway distributes from 0.6 to 2.6 s while drivers quit ACC, median number of 1.5 s and average value 1.5 s. The maximum is 2.6 s of the systemic exploring maximum value, the minimum value as 0.3 s (Fig. 42.5). According to the driving habits of subjective questionnaires inquiry of drivers, radical drivers tend to brake when cars run before them and dangerous conditions; the time headway of this braking ranges from 0.3 to 1.5 s. While the conservative drivers tend to brake vehicles when finding cars before them, the time headway of this kind ranges from 0.6 to 2.6 s.



**Fig. 42.5** The frequency number of time headway when the test vehicle goes straight and approaches the front vehicle. The distribution of time headway between 0.3 and 2.6. The median and average was 1.5 s

**Fig. 42.6** The frequency number of time headway when other vehicles enter the lane. The time headway between 0.2 and 2.6



The difference between self-adaptive cruise system and drivers also manifests that while other vehicle switches to this lane, drivers tread braking pedal to decelerate for avoiding other vehicles [4] so as to prevent test car bumping under adaptive cruise system control [4]. Time headway ranges from 0.2 to 2.6 s when drivers brake under this working condition. We can conclude for classifying analysis about this difference. The first kind, when the time headway is 2.6 s, the working condition of drivers' braking is other vehicles open the steering lights, not switching to or incompletely switching this lane; the second kind, when the time headway is 0.2–2.2 s, the working condition of drivers' braking is other vehicles switching into this lane. Under the second working condition, the average value of time headway is 0.8 s. Although the difference of this kind appears fewer times during this testing process, the bumping risks are still higher than straight-running vehicle working condition due to the shorter time headway (Fig. 42.6).

### 42.4 Conclusion

This paper develops the practical vehicle and road testing through erecting self-adaptive cruise system testing platform, collects and analyzes the true and objective environmental data, vehicles data, and driving action data, and concludes that self-adaptive cruise system is mainly used for higher vehicle speed. 74.5 % of the drivers are very satisfied with the self-adaptive cruise system; 25.5 % of the drivers are not satisfied or not very satisfied with the system. The drivers would quit self-braking cruise system by braking under some working conditions. The time headway of quitting ranges from 0.2 to 2.6 s.

Through this research, this paper can provide basis for self-adaptive cruise system of vehicle upgrading. Meanwhile, we will utilize the experimental data and analyzing method and go into research to adaptive cruise system and drivers' human-machine interacting features, so as to establish the self-adapting cruise principle system meeting the drivers' behavior characteristics.

## References

1. Marsden G, McDonald M, Brackstone M (2001) Towards an understanding of adaptive cruise control. *Transp Res Part C Emerg Technol* 9(1):33–51
2. Winner H (1996) Adaptive cruise control system: aspects and development trends. In: Overview and update of ITS system developments, no. 961010. SAE technical paper
3. Sayer JR (1996) Intelligent cruise control-issues for consideration. *Training* 2010:03–15
4. Larsson AF (2012) Driver usage and understanding of adaptive cruise control. *Appl Ergon* 43(3):501–506
5. Stanton NA, Young MS (2005) Driver behaviour with adaptive cruise control. *Ergonomics* 48(10):1294–1313
6. Hoedemaeker M, Brookhuis KA (1998) Behavioural adaptation to driving with an adaptive cruise control (ACC). *Transp Res Part F Traffic Psychol Behav* 1(2):95–106
7. Jones S, Philips BH (2013) Cooperative adaptive cruise control: critical human factors issues and research questions. In: In 7th international driving symposium on human factors in driver assessment, training, and vehicle design
8. Nilsson J, Strand N, Falcone P, Vinter J (2013) Driver performance in the presence of adaptive cruise control related failures: implications for safety analysis and fault tolerance. In: Dependable systems and networks workshop (DSN-W), 2013 43rd annual IEEE/IFIP conference on, IEEE, pp 1–10
9. Bifulco GN, Pariota L, Simonelli F, Di Pace R (2013) Development and testing of a fully adaptive cruise control system. *Transp Res Part C Emerg Technol* 29:156–170
10. Beggiano M, Krems JF (2013) The evolution of mental model, trust and acceptance of adaptive cruise control in relation to initial information. *Transp Res Part F Traffic Psychol Behav* 18:47–57
11. Schleicher S, Gelau C (2011) The influence of cruise control and adaptive cruise control on driving behaviour—a driving simulator study. *Accid Anal Prev* 43(3):1134–1139
12. Nowakowski C, O’Connell J, Shladover SE, Cody D (2010) Cooperative adaptive cruise control: driver acceptance of following gap settings less than one second. In: Proceedings of the human factors and ergonomics society annual meeting. SAGE Publications, vol 54(24), pp 2033–2037

# Chapter 43

## Plateau Alpine Environment Impact Study of a Certain Type of Air Defense Missile

Zhibing Pang, Honglei Li, Qiang Gao, Cheng Jin, Xingbin Zhu  
and Yuankang Sun

**Abstract** This chapter summarizes the environmental characteristics of plateau cold area; a certain type of air defense missile is analyzed in the plateau cold area that are faced with the natural environment, based on the temperature, pressure, humidity, solar radiation, wind, and thunder factors such as the study of the impact of a certain type of air defense missile; puts forward the corresponding measures of protection for the improvement of a certain type of air defense missile plateau alpine environment adaptability; and fighting capacity generation plays an important role in promoting equipment, similar to other equipment, to carry out the study has certain reference significance.

**Keywords** Plateau alpine the environment · Surface-to-air missile · Impact

### 43.1 Introduction

In order to deal with and win plateau cold area the possibility of local war, strengthen the application a certain type of air defense missile environment adaptability research is particularly important, on the basis of summarizing the characters of the plateau cold area environment, analyzed the influence of the main environmental factors on the weapons and equipment, and puts forward targeted measures, to promote the performance of the performance of the technologies of equipment war environment adaptability and fighting capacity, improve equipment and ascension is of great significance. At the same time for troops to equipment scientific and reasonable management, use, and maintenance to provide basis and reference.

---

Z. Pang (✉) · H. Li · C. Jin · X. Zhu · Y. Sun  
Air Defence Forces Academy, Zhengzhou 450052, China  
e-mail: fkb\_mmes@163.com

Q. Gao  
Unit71271 of PLA, Qing Dao, China

## **43.2 Plateau Cold Area Environmental Characteristics**

The area of the plateau cold area in China is very wide, 1,000 m above sea level more than 58 % of the total land area, 2,000 m above sea level of the region more than 33 % of the total land area, and there are more than thousands of miles of plateau and alpine boundary. The region has a low temperature, low pressure, high altitude, low air humidity, wind, dust, typical plateau climate features such as frequent thunder and lightning. These typical natural environment factors will influence each other, and then induce other environmental factors.

### ***43.2.1 Low Temperature***

According to statistics, every rise 1,000 m above sea level, the same latitude area atmospheric temperature is 6.5 °C. And if the higher altitudes, the low-temperature stage is longer, at an altitude of 4,000 m, is fixed cold area, the annual average air temperature is below 4 °C, the cold phase is more than 5 months; If the temperature difference between day and night, the greater the temperature differences will be up to 30 °C, extreme minimum temperature of 27–45 °C.

### ***43.2.2 Depression***

In general, each rise 1,000 m above sea level, the atmospheric pressure fell by 9 %. If the elevation is high, the boiling point of level, the lower the height of 4,000 m, water boiling point has dropped to below 90 °C. Therefore different altitude atmospheric pressure is the local per unit area is determined by the gravity of the vertical column of air [1].

### ***43.2.3 Low Humidity***

The region climate is dry, less rainfall. Because of the plateau cold area particularly strong solar radiation, rainfall is small, the surface is very dry, evaporation is generally greater than that of precipitation around five times, and the annual average relative humidity is less than 50–70 %.

### ***43.2.4 The Sun's Radiation***

Because plateau cold area air transparency is better, so particularly strong sunshine radiation, annual total radiation dose is higher than the loess plateau, the north

China plain is 4.2–16.8 kJ/m<sup>2</sup>; radiation is strongest in May (7.1–10.5 kJ/m<sup>2</sup>), every rising is 1,000 m above sea level of about 10 %; and more than 3,000 meters area increased slowly.

### ***43.2.5 The Wind***

Every year has faced wind's long period of time, wind speed, maximum 20–28 m/s, the annual average wind speed of 3 m/s; wind pressure is small, each rise is 1,000 m above sea level; wind pressure fell 9 %, with less vegetation; soil and air humidity is small, so the large amount of dust, dust quantity according to different regions, is in low altitude, dusty air dust content density is of more than 5 times.

### ***43.2.6 Thunder and Lightning***

Thunder–lightning channel is rapidly expanding gas burst of sound. Burst pressure can reach 50 atmospheric pressure, fast attenuation of sound waves. Lightning energy focused primarily on 0.5–6 HZ sound. Thunder propagation distance in land is generally not more than 25 km. Lightning effects include the thunder overpressure, vibration, lightning ionization, electric shock, the effect of strong electric field, etc.; of all kinds of equipment that may affect and effect on the missile system is obvious, communications, radar, search, missile launch, etc., will be restricted by lightning weather.

## **43.3 The Influence of Environmental Factors on a Certain Type of Surface-to-Air Missile and Protection**

### ***43.3.1 Low Temperature***

#### **43.3.1.1 For a Certain Type of Surface-to-Air Missile**

- (1) Made of rubber, plastic products harden, and easy to break and rupture, lead to bad sealing;
- (2) Makes grease viscosity increase and even freeze, which resulted in increased friction transmission mechanism and the rotation difficulties.

#### **43.3.1.2 Safeguards**

- (1) In addition to the daily maintenance work, should also pay attention to priority selection has good low-temperature properties and anti-aging performance of seal;



- (2) The antenna-drive car, before the jump to manually turn the 2–3 laps, prevents due to the lubricating oil viscosity, the rotational resistance is too large, due to start-up and burn out power amplification motor or perform [2].

### **43.3.2 Low Pressure**

#### **43.3.2.1 Influence on a Certain Type of Air Defense Missile**

- (1) Effect on combustion

Depression affects lighting time, burning time, reduce the efficiency of ground vehicles, thrust, reduce tension, engine starting work, and unstable;

- (2) The influence of the structure

Gas or liquid easy leakage or leakage rate increases from the sealed container, the seal requirements is of certain importance in electrical products, which will also indirectly affect its electrical properties; likewise, in case of pressure container, the pressure change caused easily leads to pressure vessel rupture [3].

#### **43.3.2.2 Protective Measures**

Depression mainly has bigger influence on the electronic equipment, so in terms of electronic equipment has the following several kinds of protective measures:

- (1) To ensure that the booth of electronic equipment used in plateau has enough puncture-resistant ability, we must increase the clearance;
- (2) Of the radar of all the equipment in the ac power cable plug, socket, and insulated.

### **43.3.3 Low Humidity**

#### **43.3.3.1 Effects on a Certain Type of Air Defense Missile**

Effects on a certain type of air defense missile reduce with sea dials average relative humidity, absolute humidity falls, the decrease of strength of external insulation, electrical and electronic equipment dry arc discharge voltage reduced. Studies have shown that altitude, every 100-m increase in electrical equipment arc of corona power frequency, dry, wet, shock discharge voltage are the conditions to reduce 1 %, result in static charges and produce electrostatic deposition, resulting in insulation breakdown, ozone, and dust accumulation [4].

#### **43.3.3.2 Rainfall Distribution on 10–12 Protective Measures**

- (1) Choose durable, not easily broken, such as organic material such as leather, rubber, and fabric;
- (2) In the corresponding components wax to prevent electrostatic, maintaining the appropriate temperature, activated carbon is placed within the cabin way to remove ozone, in a timely manner to wipe dust.

### ***43.3.4 Solar Radiation***

#### **43.3.4.1 Track of the Influence of Surface-to-Air Missile**

High solar radiation causes a certain type of air defense missile training in use process; higher internal temperature of the electronic device of booth accelerates the aging of organic insulating material; out the protective coating aging seriously, which affects the service life. It is mainly manifested in two aspects:

- (1) make the element damage, which leads to welding crack, solder joint release;
- (2) strong solar radiation and temperature change are big combination to make coating, faded and other protective layer cracking, blistering, peeling, and encapsulating compound.

#### **43.3.4.2 Protective Measures**

- (1) Improve the chariot, the surface of the radar antenna equipment, such as coating material, improves the ability to resist ultraviolet ray;
- (2) Hydraulic hose can consider adopting protective measures such as adding protective sleeve or select better UV protection, and cold-resistant material, to prolong service life and has good effect to prevent blowout [5].

### ***43.3.5 The Wind***

#### **43.3.5.1 Track of the Influence of Surface-to-Air Missile**

The wind for a certain type of surface-to-air missile main effects includes:

- (1) Can affect the normal search radar antenna start and rotating speed;
- (2) Wind shear stress much on the movement of vehicles car causes an accident.

#### **43.3.5.2 Protective Measures**

- (1) Regularly check equipment surrounding the aggradation, sundry, greening, the training time to time, cover to cover the equipment; after the strong wind to the equipment for inspection and maintenance;
- (2) The cable connector, plug, and socket should bind tightly, use the old cloth till they are exposed to mechanical oil bandage, and the air strainer mesh to wash oil in time, all the above improves the ability to dust filtering;

### ***43.3.6 The Thunder***

#### **43.3.6.1 Track on the Influence of Surface-to-Air Missile**

Plateau cold area of thunderstorm weather, and the weather is dry, easy to produce static, lightning and electrostatic effect of electronic products is relatively obvious, lightning way has two kinds of lightning strike and indirect ray. Lightning damage to the equipment is great, but under the lightning protection is rare; Indirect lightning influentially harms the electronic equipment in three cases, respectively: high voltage, static induction effect of lightning current, and electromagnetic field effect may cause the product does not work, even burning equipment or components.

#### **43.3.6.2 Protective Measures**

- (1) For lightning protection, it is important to note that underground water level is low in plateau in the dry season, the soil is relatively dry, attention should be given to the grounding of the lightning rod effect;
- (2) In view of the indirect ray protection, after lightning protection devices can be added and used for the key parts in the form of system earthing and protection.

### **43.4 Conclusion**

Plateau cold area of bad natural environment of a certain type of air defense missile equipment is add discussed seriously; the influence of practice has proved that the protective measures can effectively reduce the natural environment of the dangers of weapons and equipment, at the same time, the measures for other weapons and equipment to carry out the significance of reference to the similar research. Environmental adaptability is one of the important quality characteristics of weapons and equipment; according to the characteristics of plateau cold area of

complex terrain environment, data acquisition work become large and meticulous, to a certain type of surface-to-air missile equipment quality and operational performance and better play, and this requires us to put environmental adaptability in strategic-level research [6], more targeted measures are put forward, and to reduce the influence of environment on the equipment, to improve equipment of environmental adaptability, to promote the rapid ascension of the equipment effectiveness.

## References

1. Plateau environment on the influence of the air defense weapon and equipment and improving measures, modern defense technology, 2011, 4
2. The influence of plateau environment on the electrical and electronic products and protective, electronic product reliability experiment with the environment, 2010, 8
3. Alpine plateau environment on the influence of the electric equipment and design requirements, engineering and technology, 2008, 4
4. The intelligence radar plateau environment adaptability, Donghai Xu, Nanjing Institute of Electronic Technology, modern radar, 2005, 7
5. Operational application method of HQ-7B surface to air missile system on HighLand, China National Defence and Technology, 2013, 11
6. Low pressure environment on the influence of military electrical and electronic products, equipped with environment engineering, 2009, 10

**Part VII**  
**Research on the Overall Performance of**  
**Man–Machine–Environment System**

# Chapter 44

## Core Sector Risk Assessment Model Based on AHP of Confidentiality

Baohang Shao and Wei Liu

**Abstract** This paper analyses the composition of the elements of risk assessment, keeping state secrets and optimize the allocation of resources for confidentiality. To protect the confidentiality of the actual needs for vital sectors, we present a risk assessment model for state secrets sector by using AHP, optimizing the allocation of resources effectively to protect state secret sector. It offers a solution focusing on core secret protection to improve the ability to keeping state secrets. This model has been applied in research projects.

**Keywords** AHP · Confidentiality · Risk assessment · Model

Improving the efficiency investment and output of confidentiality and closely hanging on to core secret are the inevitable selection of improving confidentiality working efficiency. Confidentiality core sectors are the highly sensitive area of producing, processing, and storing confidential information of units and the gathering place of core secrets, which is the priority of priorities of unit confidentiality safety prevention. Adopting effective protection on confidentiality core sectors is closely connected with risk assessment [1]. Risk assessment is the basis of configuring confidentiality resources reasonably and optimizing confidentiality implementing scheme. Under the premise of drastic expanded information, increasingly complex confidential environment, gradually diversified confidentiality requirement and the limited confidentiality investment and resources utilization difficult to meet the demand of confidentiality safety, adopting confidentiality assessment is the effective means to conduct confidentiality tasks in different levels, firmly get to the heart of core confidentiality protection, implement the precision management of manpower, materials resources and property, improve the investment/production ratio of confidentiality work, lay solid

---

B. Shao (✉) · W. Liu  
PLA Institute of Physical Education, Guangzhou, China  
e-mail: 523155497@qq.com

B. Shao · W. Liu  
Guangdong University of Finance, Guangzhou, China

foundation for improving working efficiency of confidentiality and purifying confidential environment and the effective pushing factors of social stability [2].

The assessment on confidentiality risks is usually analyzed on models. This paper utilizes the analytic hierarchy process (AHP) and proposes the risk assessment model on confidentiality core sector on the basis of analyzing the confidentiality risk assessment factors.

## 44.1 Factors Affecting Confidentiality Risks

There are many factors affecting risks. Generally, they mainly include the levels of state secret of confidentiality units, quantity of different levels of state secret, personnel scope (informed scope) contacting with the state secret at different levels, and confidentiality period of confidential information at different levels [3]. Generally, the higher the confidential level of confidential information is, the wider of the known scope and the longer the confidentiality period, then the higher the confidentiality risk of confidential unit is.

With the purpose of assessing the confidentiality risks of confidential units, the confidentiality risk value  $A$  may be used to quantify the confidentiality risks; the risk level due to the different secret levels and quantities may be confirmed as  $B_1$ ; the risk level due to the different known scopes may be confirmed as  $B_2$ ; the risk level due to the different confidentiality scopes may be confirmed as  $B_3$ . By this means, the confidentiality risk value  $A$  is the functions of  $B_1$ ,  $B_2$  and  $B_3$ , and  $A \propto (B_1, B_2, \text{ and } B_3)$ .

## 44.2 The Establishment of Risk Assessment Model [4]

### 44.2.1 Risk Level $B_1$ Confirmed by Different Secret Levels and Quantities

According to the *Law of the People's Republic of China on Guarding State Secrets*, the state secrets shall fall into three categories: most confidential, classified, and confidential in accordance with the damage extent of harm to state security and national interests. In a unit, the different levels of state secrets and the quantity of state secrets at all levels would produce different risk levels. Risk levels  $B_1$  may be used to assess them.

Provided that the quantities of involving confidential information in a year are secret  $x_{11}$ , most confidential pieces; secret<sub>12</sub>, classified pieces; and secret<sub>13</sub>, confidential pieces and provided that  $c_{11}$ ,  $c_{12}$ , and  $c_{13}$  represent three secret levels of most confidential, classified, and confidential, with the weight of  $w_{11}$ ,  $w_{12}$ , and  $w_{13}$ .

$$\text{If } B'_1 = \sum_{j=1}^3 w_{1j} x_{1j}, \text{ then } 0 \leq B'_1 < +\infty.$$

The selectable risk level  $B_1$  is  $B_1 = 1 - e^{-B'_1}$ . And we can know that  $0 \leq B_1 \leq 1$ .

According to the national laws and regulations, the authorities and departments involving 1 most confidential or 3 classified or 10 confidential state secrets are defined as the confidentiality core sectors. Thus, the  $D_1$  of comparison judgment matrix of  $c_{11}$ ,  $c_{12}$ , and  $c_{13}$  shall be as follows.

$$D_1 = \begin{matrix} & \begin{matrix} c_{11} & c_{12} & c_{13} \end{matrix} \\ \begin{matrix} c_{11} \\ c_{12} \\ c_{13} \end{matrix} & \begin{bmatrix} 1 & 1/3 & 1/10 \\ 3 & 1 & 3/10 \\ 10 & 10/3 & 1 \end{bmatrix} \end{matrix}$$

According to comparison judgment matrix, calculate as per the sum method

$$\begin{cases} w_{11} = 0.0714 \\ w_{12} = 0.214 \\ w_{13} = 0.714 \end{cases}$$

### 44.2.2 Risk Level $B_1$ Confirmed by Different Known Scopes

According to the working posts, political quality, style quality, business quality, and psychological quality of the personnel involved in confidentiality, the personnel involved in confidentiality of the core sectors can be classified as general secret-related personnel, important secret-related personnel, and core secret-related personnel. As for the confidentiality core-related department of a unit, the quantity of three kinds of secret-related personnel reflects the different levels of secrets and specific state secret and known scope, influencing the key core sectors and risk levels of state secret.

Provided that the key department of a unit has general secret-related personnel  $x_{21}$ , important secret-related personnel  $x_{22}$ , and key secret-related personnel  $x_{23}$ , then their weights are  $w_{21}$ ,  $w_{22}$ , and  $w_{23}$ , respectively.

Provided that  $B'_2 \stackrel{A}{=} \sum_{j=1}^3 w_{2j} x_{2j}$ , it can be known that  $0 \leq B'_2 < +\infty$ .

The risk level to be selected is,  $B_2 = 1 - e^{-B'_2}$ , it can be easily known that  $0 \leq B_2 \leq 1$ .

Take  $c_{21}$ ,  $c_{22}$ , and  $c_{23}$  to illustrate the categories of general secret-related personnel, important secret-related personnel, and key secret-related personnel. According to the secret-involved extent of different levels, it can be known that the comparison judgment matrix  $D_2$  can be listed as

$$D_2 = \begin{matrix} & \begin{matrix} c_{21} & c_{22} & c_{23} \end{matrix} \\ \begin{matrix} c_{21} \\ c_{22} \\ c_{23} \end{matrix} & \begin{bmatrix} 1 & 1/5 & 1/9 \\ 5 & 1 & 1/5 \\ 9 & 5 & 1 \end{bmatrix} \end{matrix}$$



According to comparison judgment matrix, calculate as per the sum method  $\begin{cases} w_{21} = 0.061 \\ w_{22} = 0.216 \\ w_{23} = 0.723 \end{cases}$ .

**44.2.3 Risk Level  $B_3$  Confirmed by Different Confidentiality Scopes**

After the state secret is produced, before disclosing, the confidentiality risk level  $B_3$  is related to confidentiality load, expressed with confidentiality load function  $z$ .

Use  $t$  to indicate the passed time of the classified materials,  $T_i$  indicate the confidentiality period required by the classified materials (if the disclosing period is not delimited, then regulate 10 years for confidential, 20 years for secret, and 30 years for most confidential), and  $\alpha_i$  indicate the grade coefficient of different classified materials. The confidentiality load function  $z$  shall meet the following requirements.

1. With the extension of a same classified material with the time, the confidentiality load lowers. It is the maximum value when “ $t = 0$ ”; it becomes 0 when  $t = T_i$ . The largest load of most confidential load shall be 1.
2. Under the circumstance of same confidentiality period, the classified materials with different levels shall have large load for the high-level classified materials.
3. As for the confidentiality materials with the same level, the ones with longer confidentiality shall have longer load.
4. The most confidential materials have the largest load for 30 years, set as 1.
5. The load is lowered to 0 when the confidential materials expire.
6. Load function is related to ( $t, T_i$ , and  $\alpha_i$ ).

According to the above conditions, the confidentiality load function  $Z = f(\alpha_i, T_i, t)$  is related to monotone decreasing on  $T_i$  and monotone increasing on  $\alpha_i$ . The confidentiality load function shall be selected as.

$$z = f(\alpha_i, T_i, t) = 1 - e^{-\alpha_i(T_i-t)}$$

Of which,  $\alpha_i$  is the confidential level;  $T_i$  is the confidentiality period,

$$i = \begin{cases} 1 & \text{Confidential} \\ 2 & \text{Classified} \\ 3 & \text{Most confidentiality;} \end{cases} \quad t \text{ is the past time after the state secret.}$$

$$\alpha_i = \begin{cases} 1/3 & i = 3 \\ 1/20 & i = 2, \\ 1/30 & i = 1 \end{cases}, \quad T_i = \begin{cases} \leq 30 & i = 3 \\ \leq 20 & i = 2 \\ \leq 10 & i = 1 \end{cases}$$

As for the state secret of the confidential level, according to the related national regulations, if there is no special regulations, the highest confidentiality period of confidential-level state secret is 10 years; that of the secret level is 20 years; and that of most confidential level is 30 years. Thus, the number of state secret of the rest “n” year of confidentiality period is  $k_n^{(1)}$ ; the confidentiality load  $f_n^{(1)}$  (n is 1,2,3...10). The number of state secret of rest “n” year of confidentiality period is  $k_n^{(2)}$ , and the confidentiality load is  $f_n^{(2)}$  (n is 1, 2, 3 ... 20). The number of state secret of rest “n” year of confidentiality period is  $k_n^{(3)}$ , and the confidentiality load is  $f_n^{(3)}$  (n is 1, 2, 3 ... 30).

The confidentiality load confirmed by  $k_n^{(1)}$ (n is 1, 2, 3 ... 10) confidential state secret is  $F_{31}$ ; the confidentiality load confirmed by  $k_n^{(2)}$ (n is 1, 2, 3...10) classified state secret is  $F_{32}$ ; the confidentiality load confirmed by  $k_n^{(3)}$  (n is 1, 2, 3 ... 10) is  $F_{33}$ . Then, the total load of  $j$  ( $j = 1, 2, 3$ ) of the classified materials is

$$F_{3j} = \sum_{i=1}^{n_j} f_i^{(j)} k_i^{(j)}$$

$$\hat{B}_3 = \sum_{j=1}^3 w_{3j} F_{3j} .$$

Then, the risk value of confidentiality period shall be written as  $B_3 = 1 - e^{-B'_3}$ .

Set  $c_{31}$ ,  $c_{32}$ , and  $c_{33}$ , respectively, representing confidential, secret, and most confidential. The comparison judgment matrix of  $c_{31}$ ,  $c_{32}$  and  $c_{33}$  shall be  $D_3$ .

$$D_3 = \begin{matrix} & \begin{matrix} c_{31} & c_{32} & c_{33} \end{matrix} \\ \begin{matrix} c_{31} \\ c_{32} \\ c_{33} \end{matrix} & \begin{bmatrix} 1 & 1/3 & 1/10 \\ 3 & 1 & 3/10 \\ 10 & 10/3 & 1 \end{bmatrix} \end{matrix}$$

Calculate the comparison judgment matrix, getting  $\begin{cases} w_{31} = 0.0714 \\ w_{32} = 0.214 \\ w_{33} = 0.714 \end{cases}$

#### 44.2.4 Risk Assessment Model of Confidentiality Core Sector [5]

With a view to assessing the risk of core department sectors, the factors of  $B_1$ ,  $B_2$ , and  $B_3$  shall be comprehensively considered. Set up the weight of  $B_1$ ,  $B_2$ , and  $B_3$  as  $w_1$ ,  $w_2$ , and  $w_3$ . Then, the overall risk value of confidentiality risk assessment shall be as follows.

$$A = w_1 B_1 + w_2 B_2 + w_3 B_3$$

Establish the comparison judgment matrix

$$D = \begin{matrix} & B_1 & B_2 & B_3 \\ B_1 & 1 & 3 & 3 \\ B_2 & 1/3 & 1 & 1 \\ B_3 & 1/3 & 1 & 1 \end{matrix}$$

Calculate the comparison judgment matrix, getting  $\begin{cases} w_1 = 0.6 \\ w_2 = 0.2 \\ w_3 = 0.2 \end{cases}$

### 44.3 The Effect Verifying and Application of the Risk Assessing Model of Confidentiality Key Departments

Select the state secret of different secret levels, quantities, known scopes, and confidentiality periods as the parameters of confidentiality key departments. Calculate the overall risk value A and utilize the above-mentioned conclusion as the verification to produce Table 44.1.

The Table 44.1 shows that total risk value A can reflect the risk change of state secret grade, quantity, the known range, and change of time meets the working actuality of confidentiality. This model can be utilized to assess the risk extent of confidentiality key departments.

**Table 44.1** Relationships among total risk value, state secret grade, quantity, the range of allowed knowing, and deadlining

Deadline	State secret grade and quantity			The range of allowed to know			Total risk value
	Confidential	Classified	Most confidential	General	Important	Core	
1 year	10	0	0	10	0	0	0.46
2 years	0	0	1	0	0	4	0.60
5 years	0	3	0	0	3	0	0.47
15 years	0	3	0	0	3	0	0.44
20 years	10	3	1	10	7	4	0.82
25 years	10	3	1	10	7	4	0.81
30 years	10	3	1	10	7	4	0.72

## 44.4 Conclusion

Utilizing risk assessment method to optimize confidentiality implementing scheme and reasonably allocate the confidentiality resources is the effective means to effectively utilize the confidentiality resources and improve the confidentiality working efficiency. These means can improve the precise management level during the implementing process of confidentiality and improve the input/output ratio of confidentiality. Presently, the risk assessment model has been used in some confidentiality scientific research subject.

## References

1. Lin J, Qian H (2007) Military secrecy. Military Science Press, Beijing, pp P159–P181
2. Cong Y (2001) Introduction to information Security .Jinchen Press, pp P9–P18
3. Liu H, Liu S (2011) Military secrecy risk management. Military Science Press, Beijing, pp P115–P135
4. Hu Y (2010) Basic and applied operations research. Higher Education Press, Beijing, pp P308–P312
5. Jiang Q (2011) Mathematical model. Higher Education Press, Beijing, pp P249–P268

# Chapter 45

## The Study on Increasing Vehicle Passing Rate at Intersection Based on Ergonomics

Jianwei Wang and Beihai Wang

**Abstract** The paper is mainly concerned with the traffic jams caused by traffic lights at intersections. Based on ergonomic principles, we comprehensively analyze the causes, establish a man–vehicle–environment comprehensive model by the analysis of behavior of drivers waiting at the traffic lights, vehicle and environment factor, find out the influence of the rate factors, and build a mathematical model. Through the numerical analysis put forward, an approach to keep a safe vehicle waiting distance at traffic lights with the consideration of the psychology and the behavior characteristics of the drivers was developed, which thereby can increase the vehicle passing rate at the traffic light junctions. And by setting the scene model, the feasibility of this method is verified.

**Keywords** Vehicle distance · Ergonomics · Passing rate · Traffic lights

With an increasing number of private cars of urban residents, traffic jam in urban area is getting worse and worse, especially various intersections and crossroads, which have become the bottleneck of the traffic. To get out of that situation, the government has successively put forward series of approaches, like optimized traffic light duration and left-turn waiting zone [1, 2], to increase the vehicle passing rate at intersections. Based on ergonomic principles and approaches, the paper comprehensively analyzes the man–vehicle–environment system, in order to explore a new approach to increase the vehicle passing rate at intersections.

---

J. Wang (✉) · B. Wang  
Wuhan Polytechnic University, Wuhan, Hubei 430023, China  
e-mail: adawangjw@163.com

## **45.1 Analysis of the Man–Vehicle-Environment System at Traffic Lights**

### ***45.1.1 Analysis on Drivers***

#### **45.1.1.1 Psychological Analysis of Drivers Waiting at Traffic Lights**

Vehicle passing rate can be affected by age group, sexual difference, and queue-jumping. Therefore, we make our analysis of the psychology of the drivers under these three situations.

##### **(1) Psychological analysis of the drivers of different age groups when waiting at traffic lights.**

The “research on vehicle driver’s attention level and its related factors” reveals that the attention level of drivers of 30–49 is obviously higher than that of those above 50 and those under 29, which explains that this group of people have a higher respond sensitivity [3]. Besides, drivers of 30–49 often drive and have clearer judgment on road condition. Owe to their calmness and high respond sensitivity, drivers of this age group can cross the junctions in a relatively short time.

##### **(2) Analysis of drivers of different gender when waiting at traffic lights.**

Generally speaking, females are characterized by timidity, sensibility, softness, humility, cautiousness, and patience. Therefore, when waiting at a traffic light, they will tend to keep a safe vehicle distance intentionally and concentrate their mind with great patience in most of the cases [4]. Compared with females, males are more independent, aggressive, bossy, and initiative, which as a result, they are inclined to get close to the car in the front as much as they can, and they are often lack of attention and patience [4].

##### **(3) Psychological analysis of queue-jumping.**

People are anxious to cross the junction when waiting at traffic lights, and when they find that the distance between the cars in the front is relatively broad, they will probably jump the queue immediately. In that case when the driver in the front notices that the car behind is trying to jump in, he will decide to shorten the distance to avoid queue-jumping out of psychological imbalance, which results in the fight between queue-jumping and anti-queue-jumping. And finally, it will lead to the narrowing down of the vehicle distance and hinder the starting of the vehicles.

Moreover, if the duration of the traffic lights is too much long, it will cause mental fatigue and the down of attention of drivers. The lowering of the alertness may lead to mis-operation and misjudgment on the road condition, which will easily cause accidents [5]. According to the “research on the optimization of the traffic lights” from Beijing youth scientific and technical innovation contest, the most acceptable traffic light duration ranges from 30 to 60 s.

### **45.1.1.2 Behavior Analysis of Drivers Waiting at Traffic Lights**

In crossing the traffic light junction, the lightening of the green light will be firstly seen by the driver's sense organs (eyes), and then the nervous system will analyze the information, then direct the motor system to control the vehicle to cross the junction [6, 7]. From the lightening of the green light to the starting of the vehicle, driver's respond time is different. We know that the behavior of the driver is mainly decided by his training and experience. For driver, his respond time is affected by his age and driving skill. Meanwhile, the behavior of a skillful driver does not need the individual to encode the display information. It is his subconsciousness that reacts to the information. Taking into consideration a driver's age and his skill and experience, his respond time is around 1–4 s [8].

### **45.1.2 Analysis of Vehicle Factor**

Driving involves the behavior of sitting. If the seat of the car is not complete and comfortable enough, it will easily cause fatigue, which will have impact on the driver's reaction and affect the passing rate. Apart from that, different starting speed and length of different vehicles also have influence on the passing rate.

### **45.1.3 Analysis of Environmental Factor**

Ergonomics is the study of the inter-coordination of man, machine, and environment to realize its optimization. Environment has a significant influence on men and machines. In our project, environmental factors involve road condition, light and color, vehicle noise, and microclimate [6, 7]. We make our analysis based on normal road condition (no obstacle on the road) and natural light condition (employ in-car temperature, 24 °C). Other factors, like noise and amplitude are at physically comfortable levels.

## **45.2 Establishment of the Passing Rate Model**

### **45.2.1 Factors and Their Definitions**

According to the above comprehensive analysis, we employ the following factors parameters:

- (1) duration of the traffic lights  $T$ ; (2) length of the vehicle  $L$ ; (3) accelerated speed of the vehicle  $a$ ; (4) starting delay time  $t$ ; (5) vehicle distance when waiting at the traffic lights  $d$ ; (6) road width as  $D$ ; and (7) width of the zebra crossing  $l$ .

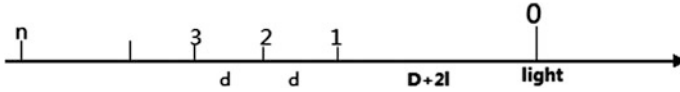


Fig. 45.1 The car axis model

### 45.2.2 Establishment of the Model

Based on the assumptions above, we establish the following model (Fig. 45.1): X-axis represents the road of the driving vehicle; 0 on the number axis is the location of the traffic lights; the positive direction of the x-axis is the driving direction of the vehicle. The vehicle starts the moment when the green light is on [9]. The first vehicle is on the left side of 0, which is 27 m far away (the width of the road plus the width of 2 zebra crossings) and the rest are  $d$  (vehicle distance) apart from each other. If the vehicle starts with constant acceleration, then to the first vehicle, we have:  $s(t) = \frac{1}{2}at^2$  (in which  $s(t)$  is the position of the vehicle on the x-axis at time  $t$ ,  $a$  is the accelerated speed of the starting). Therefore, to the  $n$ th vehicle, its distance from 0 is:  $s_n = -[(n - 1)(L + d) + 27]$ .

And the starting time of the  $n$ th vehicle is  $t_n = (n - 1)t$ ; hence, the distance of the  $n$ th vehicle at  $t_n$  time is  $s_n(t) = s_n(0) + \frac{1}{2}a(T - t_n)^2$

However, on urban roads, the speed will be limited to  $V$  (m/s). Assume that after the lightening of the green light, a vehicle starts and keeps accelerating until it reaches its limited speed and then keep driving at that speed. Thus, the acceleration time of the vehicle is  $V/a$ . And the driving trend of the vehicle after the lightening of the green light is:

$$\begin{aligned}
 s(t) &= \frac{1}{2}at^2 \\
 s_n(0) &= -[(n - 1)(L + d) + D + 2l] \\
 s_n(t) &= s_n(0) + \frac{1}{2}a(T - t_n)^2 \\
 s_n(t) &= s_n(0) + \frac{1}{2}a\left(\frac{V}{a}\right)^2 + V\left(T - \frac{V}{a} - t_n\right)
 \end{aligned}$$

The mathematical model above reveals that when  $s_n(t) \geq 0$ , it shows that the vehicle has already crossed the traffic lights. And we can have the numerical value of  $D$  when  $n$  reach its biggest number during time  $T$ . Hence, if we paint segment lines at the junctions based on the numerical value of  $d$  to ensure the distance between vehicles, we can assure that the most vehicles can cross the intersections during time  $T$ , which can help to reduce traffic jams.



### 45.3 Verification and Application of the Passing Rate Model

#### 45.3.1 Scene Setting

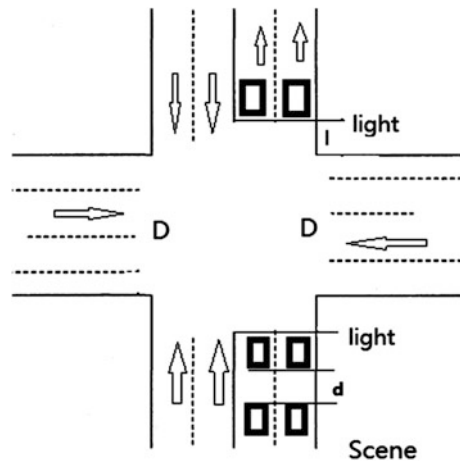
- (1) Road setting: According to the *Road traffic signs and markings*, we chose a certain intersection of a second-tier city. Suppose that it has 4 lanes (no isolation strip in the middle) and two 1.5-m-wide drainage ditches on both sides, which the total width is 15 m. Based on the average pedestrian volume in second-tier cities, we can estimate that the width of the zero crossing is 6 m (Fig. 45.2).
- (2) All vehicles go straight and cross the junction, and only vehicles on the very side of the road are taken into account.
- (3) Starting delay time of all vehicles is equal.
- (4) Length of the vehicles is the same and all vehicles start from standstill with constant acceleration.
- (5) The first car is on the side of the zero crossing when waiting at the traffic lights. And the rest share the same vehicle distance.

#### 45.3.2 Specific Parameters

According to the above comprehensive analysis of man, vehicle, and environment, we employ the following parameters:

- (1) Green light duration:  $T = 40$  s.
- (2) Length of vehicle:  $L = 4.5$  m.
- (3) Accelerated speed:  $a = 2$  m/s<sup>2</sup>.
- (4) Starting delay time:  $t = 2$  s.
- (5) Vehicle distance when waiting at traffic lights:  $d$ .
- (6) Width of the road:  $D = 15$  m.
- (7) Width of the zero crossing:  $l = 6$  m

**Fig. 45.2** The passing scene model



Suppose that the speed on urban road is limited to  $V = 60$  km/h, that is  $V = 16.7$  m/s. The time to reach that speed is:  $V/a = 8.35$  s, which requires the vehicle to completely cross the zero crossing at the other end during that period of time. After calculation, we know that when  $d = 1\text{--}2.9$  m,  $n = 15$ . It explains that when the vehicle distance ranges from 1 to 2.9 m, 15 vehicles can cross the junction at a time at most. From that, we know that we can ignore the length of the vehicle, and paint waiting lots to limit the waiting cars based on  $L + d$ . In another word, we can paint waiting lots, 6 m in apart from each other.

## 45.4 Conclusion

With the help of ergonomic principles, we analyze the psychology and the behavior of the drivers and establish a comprehensive model. Through scientific approach, we find that we can increase vehicle passing rate by painting waiting lines. It theoretically proves that it helps to reduce traffic jams at intersections. However, our theory has not been verified in reality. Due to that traffic flow varies from city to city, the model has to be verified and revised based on reality before it comes into practical use.

## References

1. Zang W (2013) Urban traffic problem analysis and solution. *Technology Vision* (23) (in Chinese)
2. Tan H, Zhang C et al (2003) The main road intersection traffic flow study. *Guangxi Norm Univ (Nat Sci)* 21(4) (in Chinese)
3. Luo T, Jiao S (2004) Attention distribution and attention ability choose in the comparison between the different ages. *Psychol Sci* 27(6) (in Chinese)
4. Cai N (2007) Female driver's psychological and behavioral analysis. *Coll J Beijing People's Procuratorate* 9(5) (in Chinese)
5. Liu Y, Sun Z, Wei Y (2007) Study of motor vehicle driver's attention and related factors. *Soc Psychol Sci* (2) (in Chinese)
6. Ding Y (2005) *Ergonomics*, 3rd edn. Beijing Institute of Technology Press, Beijing (in Chinese)
7. Guo F et al (2006) *Ergonomics*. Machinery Industry Press, Beijing (in Chinese)
8. Han Y (1997) Driver reaction time test and mathematical processing method. *Psychol Sci* (20) (in Chinese)
9. Peng G (2002) Two examples about mathematical modeling. *Southwestern Guizhou Nat Teachers Coll* (1) (in Chinese)

# Chapter 46

## A Research on BDS-Based Air Observation and Surveillance System

Zhibing Pang, Haitao Zhao, Hong He, Chenhui Li, Jiang Wu and Hongyan Ou

**Abstract** The paper makes an analysis of the problems arising from PLA air defense force (ADF)'s air observation post system as low accuracy in positioning measurement, long delay in air information transmission, difficult identification of aerial targets, limited range of disposition of observation posts, unsmooth transmission of coordinated information, and low confidentiality in air information transmission, and puts forward a systemic transformation of the visual observation posts in respect of reconnaissance equipment, network structure, air information transmission, etc., by use of Beidou navigation satellite system (BDS). It presents an idea of making up an air defense observation and surveillance system composed of observation subsystem, air information identification subsystem, information processing subsystem, information transmission subsystem, and command and control subsystem in order to enhance ADF-integrated reconnaissance and early-warning capability in joint-operation conditions.

**Keywords** Reconnaissance and early warning · Beidou navigation · Satellite system · Air information transmission · Air observation posts

The air strike and counter air strike operations initiate the modern warfare and go through the whole process of it. To conduct discovery and strike earlier than the enemy must require timely, accurate, and continuous air information support, which is the important link of air defense operations [1]. At present, PLA air observation depends on radar reconnaissance network, air observation post network, and position (command post) observation network. The complicated battlefield electromagnetic environment and the strong adversary electronic jamming make the air defense radars difficult in disposition, start-up and early warning, being placed in a situation of threat and pressure. Moreover, because of different geographical environment of operations, AD radars may have corresponding blind zones. Therefore, the air observation posts should be disposed in whole area and

---

Z. Pang (✉) · H. Zhao · H. He · C. Li · J. Wu · H. Ou  
Air Defense Forces Academy, Zhengzhou 450052, China  
e-mail: fkb\_mmes@163.com

combined in a comprehensive network to achieve a united coordination, distant and close cooperation, and optical and electrical integration. It is imperative to make an all-direction, multi-layer, and multi-dimension BDS-based air defense force (ADF) air observation and surveillance system.

## **46.1 Problems of ADF Air Observation Posts**

In order to ensure the timely and accurate display of the early-warning capability of air defense radars and enhance the efficiency of air observation and surveillance, it is necessary to make a rational disposition and employment of air observation posts. In the complex electromagnetic environment, the air observation posts are the important means to make up the early-warning deficiency of AD radars and obtain the low and very low altitude penetration information. But, the reconnaissance instruments attached to ADF observation posts are of poor quality and low tactical and technical performances as limited reconnaissance range and accuracy, backward air information reporting means, and low efficiency of information transmission. Moreover, restricted by reconnaissance instruments and close disposition range, it is difficult to make up a large-scale network of air observation posts. These problems cause limited reconnaissance and surveillance space, close-tracking and early-warning range, slow reaction of operations, and delay in air information transmission for PLA ADF. The air observation posts are difficult to satisfy the need of multi-direction, large-zone, high-intensity, and high-speed air information support of joint air defense operations in conditions of informationization.

### ***46.1.1 Low Accuracy in Positioning Measurement***

At present, ADF air observation posts still employ the traditional method of map-plus-compass. It is of low positioning accuracy, which cannot meet the requirements of the joint air defense operations. The air observation posts lack the advanced photoelectric reconnaissance instruments and air information transmission instruments. Mainly depending on the optical instruments, they are incapable of accurately measuring aerial target bearing, elevation and range, and can only report the coarse air information. Furthermore, each observation post may cause different coordinates in time and space, and delay transmission due to manual operations. Therefore, it is difficult for the command post to master the accurate information of the aerial targets. Recently, ADF made a modification and had developed an air information reconnaissance, surveillance, and transmission system for the observation posts.

### ***46.1.2 Long Delay in Air Information Transmission***

When the operators in the observation posts carry out air reconnaissance and surveillance, they mainly use the optical instruments that are incapable of transmitting the information. These optical instruments should be connected with the wire and wireless communication system to transmit the information to the command post. This transmission mode is easily affected by the tactical and technical performance of the instruments, operating level of the operators, meteorological and terrain conditions, and electromagnetic environment, which cannot achieve the real-time and reliable transmission of the information. Furthermore, the discrepancy in operating skills results in a long delay in air information transmission, which makes difficulty for the command post in air information integration and target judgment.

### ***46.1.3 Difficult Identification of Aerial Targets***

ADF observation post is greatly affected by the natural conditions due to lack of laser, infrared, and glow reconnaissance instruments. The aerial targets are mainly identified visually by the operators. Such judgment is influenced by the personnel's quality and subjective capability. The observers usually cannot accurately and promptly judge the type of the aircraft, etc., according to some information of the aerial target. It is a matter of urgency to develop an image-oriented aerial target auxiliary identification system.

### ***46.1.4 Limited Range of Disposition of Observation Posts***

The wire and wireless communication instruments currently employed by the observation posts usually belong to tactical level with limited performances. In particular, in the complicated battlefield and electromagnetic environment, the effective communication only reaches such a close range that it cannot meet the disposition range of the observation posts. This situation confines its disposition range of the posts and shortens the discovery range of the aerial targets, which exerts a direct influence on ADF reconnaissance and early-warning efficiency.

### ***46.1.5 Unsmooth Transmission of Coordinated Information***

ADF observation posts are disposed in star-shaped structure so that each observation post is directly connected with the command post. The obvious communication flow easily exposes the location of the command post. Moreover, the

command post has to integrate all the air information that affects its command and auxiliary decision making and hinders the realization of integration of reconnaissance and strike. Therefore, a star-plus-circle structure should be put into consideration so that each observation post can be connected with each other. Based on unification of time and coordinates, the air information can be integrated to make up a unified air observation and surveillance map, which is convenient for the commanding officers to conduct command, decision making, and fire power strike.

#### ***46.1.6 Low Confidentiality in Air Information Transmission***

Restrained by the wire communication means, the distant observation posts usually employ wireless tactical communication means. Though the wireless communication is encrypted, but the encryption grade is not very high resulting in low confidentiality. Moreover, the various instruments are mainly operated manually, and the difference in operators' skill will affect the air information transmission.

Therefore, in order to realize the systemic construction of ADF air observation and surveillance, make each observation post to be networked, and enhance its tracking and information-unifying capability, no efforts should be spared to apply new technology, new method, and new means in air defense observation posts.

### **46.2 Conception of Air Defense Observation and Surveillance System**

The traditional air observation posts mainly observe the air from the ground. With the development of the aerospace technology, it needs to apply the aerospace capability to the tactical level [2]. Beidou navigation satellite system (BDS) was put into public service in Dec 28, 2012, which may also provide high-accuracy positioning, navigation, timing, and communication for the army [3]. Beidou navigation satellite system (BDS for short) may achieve positioning, orientation and navigation, unify the military standard time of weapons and equipment, and realize coded command in large area of operations.

On investigation, ADF above battalion are currently equipped with various BDS user facilities. Some user facilities even go to the echelon of battery or platoon. It makes it possible to make up a BDS-based air observation and surveillance system. In order to meet ADF requirements of air information support for multi-direction, large-area, high-intensity, and high-speed joint air defense operations in conditions of informationization, the superiority of BDS should be brought into the modification of air defense observation posts. Thus, a BDS-based ADF air observation and surveillance system should be made up by optimizing the existing reconnaissance instruments and presenting the new model reconnaissance instrument or system.

### ***46.2.1 Fundamental Design Ideas***

Based on the research of BDS-based air observation and surveillance system, guided by the important thought of “Troops training should be oriented to actual combat, and military institutions’ education oriented to troops” and required by ADF reconnaissance and early-warning development, BDS should be utilized for the air observation and surveillance system to realize multi-layer, large-area, and multi-dimensional network. Therefore, ADF integration of reconnaissance and strike has a solid foundation to build on.

### ***46.2.2 Composition and Function of the System***

The present ADF observation posts is weak in networked level and air information sharing, and slow in target information transmission with limited communication support range, which is difficult to adapt to integrated joint air defense firepower strike. The modularized modification by means of BDS will make air observation posts networked and existing air information reconnaissance instruments connected. An air observation and surveillance system will be constructed to achieve distant air information reporting, dangerous zone early warning, firepower request, and firepower designation and make multi-reconnaissance means synchronized, and intelligence fused and shared.

#### **46.2.2.1 Observation Subsystem**

This subsystem is in charge of observation instrument self-positioning, target search and discovery, coordinates measurement, and tracking and surveillance. Observation instrument self-positioning means to transmit the positioning application command to BDS satellite by use of BDS user facility and determine the accurate coordinates of the observation instrument according to information given by the satellite. Target search means to search in the aerial space covered by optical and night-vision instruments and discover the target in time. Coordinates measurement is to measure the bearing and elevation of target central point relative to the optical instrument central point by means of optical instrument and to measure the distance from the target central point to laser range finder by means of laser measurement technology, which are then supplied to information processing subsystem.

#### **46.2.2.2 Air Information Identification Subsystem**

This subsystem serves to conduct target auxiliary identification after discovery of the target. It may assist the observers to promptly and accurately judge the type of

target. According to some target characteristics input by the observer, it shows all the targets that accords with these characteristics and makes auxiliary judgment.

#### **46.2.2.3 Information Processing Subsystem**

This subsystem is to process the target information, determine the target position, and encode the transmission information. According to the target information obtained by observation subsystem, it calculates the target-moving parameters on the basis of the positioning information of the employed instruments and encodes the air information in accordance with air information encoding requirements.

#### **46.2.2.4 Information Transmission Subsystem**

This subsystem is to transmit the air information through BDS. After edition of the information, the observer uses the handset of BDS to transmit the information directly to the command post through BDS, which provides the auxiliary decision making for the commanding officers.

#### **46.2.2.5 Command and Control Subsystem**

This subsystem is to make a corresponding function module in command and control information system of the command post to assist the commanding officer to conduct a series of activities as air information analysis, combat command, and firepower strike. The subsystem mainly serves the function of information reception, information fusion, threat assessment, and analysis and decision making.

When it receives the information from the observation post, the command post may display the position of the target. When several observation posts transmit the target information at the same time, it may fuse the data of the target information. In air defense operations, when a series of aerial coordinates have been acquired, the moving course of the target can be predicted according to the various target positions and the threat level of the target can be assessed, which helps the commanding officers make analysis and decision making.

### **46.3 Key Technologies in Systemic Construction**

The distinctive feature of this observation and surveillance system is to bring the BDS into full play as conducting transmission and fusion of information. BDS is China-developed navigation satellite system with independent property rights. Though there exists a gap between BDS and other advanced global navigation



satellite systems, it may fundamentally satisfy PLA operations and training, put an end to the situation of PLA troops and equipment depending on other countries' positioning system, and realize its regional disposition with its own technology.

### ***46.3.1 Satellite Positioning and Communication Technology***

BDS to date has 14 satellites in orbit. It may provide accurate positioning for users with positioning accuracy of 10 m, velocity accuracy of 0.2 m/s, and timing accuracy of 50 ns. Its service coverage now reaches as far as the south hemisphere with China as its main service area. Thus, the observation and surveillance network by means of BDS is no longer constrained by the range covered by the traditional communication means. BDS may send 120 characters by use of its satellite channel and will achieve as many as 1,000 characters in the future, which may satisfy ADF air information transmission. At the same time, BDS adopts user grading and encryption technology so that the reliability and confidentiality of air information transmission are ensured [4].

### ***46.3.2 Laser Ranging Technology***

Compared with optical instruments equipped in ADF observation posts, laser ranging technology is of high stability and accurate measurement. The combination of the laser ranging equipment with BDS may ensure the measuring accuracy of the aerial targets, unify the coordinates in time and space, optimize the air information data structure, and be convenient for fusion of air information. Moreover, the laser ranging technology has come into maturity. It is necessary to intensify its application in reconnaissance and early warning of air defense operations to improve multi-technology and multi-means air surveillance function and reconnaissance result.

### ***46.3.3 Information Fusion Technology***

The complexity of modern warfare intensifies increasingly. The multi-source information systems of the complicated backgrounds come into being. It promotes the development of information fusion technology, which is widely used in command and control systems and various weapons [5]. As far as the observation and surveillance system is concerned, the application of the information fusion is divided into the following: Firstly, unified calculation of aerial target coordinates from multi-sources by information fusion technology is more efficient than unified analysis and calculation in manual mode. Secondly, the target information from

the various air information data sources will be fused and processed to acquire the key characteristics for aerial target auxiliary identification. Thirdly, match BDS coordinates with the air observation posts to reduce the error of manual positioning and timing operation and improve the consistency of the reference.

## 46.4 Conclusions

The design and building up of air observation and surveillance system based on BDS, especially the development of its softwares and hardwares must facilitate the observation and rapid transmission of the air information and preparation of firepower units. The global navigation, positioning, and communication performances of BDS may largely expand the disposition and surveillance range of air observation posts. Thus, the ADF reconnaissance and early-warning capability will be greatly enhanced in regional joint air defense.

## References

1. Zou K, Pang Z (2002) An introduction to ADF reconnaissance theory. Zhengzhou Air Defense Forces Academy, Zhengzhou
2. Tan S (2008) Development and thinking of Beidou navigation satellite system. *J Astronaut* 29(2):391–396
3. Li Y et al (2012) Navigation and positioning (the second edition)—the big dipper of informationized warfare. National Defense Industry Press, Beijing
4. Fan B, Li Z, Liu T (2008) The application of BDS in Wenchuan earthquake and suggestions. *Spacecr Eng* 17(4):6–13
5. Zou A et al (2010) The influence of navigation warfare on high-tech war and its enlightenment on CPLA. *Space Electron Technol* 2010(4):26–29

# Chapter 47

## Design on Mobile Interactive Control for a Space Flight Training Simulator

Shang Huan, Baozhi Wang and Wanhong Lin

**Abstract** *Objective* To optimize the resources and improve the autonomy of space flight training. *Methods* The mobile interactive mode to simulator was presented based on hand-held mobile terminal. Accessing the server by WiFi, the terminal was able to control running simulation program and replace the instructor's desk of the simulator. *Results* It was shown that the terminal made the interactive interface to simulator more simple and friendly with the complete function. Comparing with the instructor's desk, it has no difference in training effect, so as to meet the autonomous demand. *Conclusion* Owe to mobile terminal, the man-machine interactive mode is expanded, the training autonomy is improved greatly and the training resource is saved at the same time.

**Keywords** Simulator · Mobile · Interactive control

### 47.1 Introduction

Space flight training-simulator (“Simulator” for short) mainly deals with the space flight task status. It is the training equipment for astronauts to perceive the task environment, master the task know-how, and correctly troubleshoot faults, with the features of safety, economy, and high efficiency [1].

The interactive control of simulators is realized through instructor's desk by which configures the flight simulation parameters, control flight simulation process, and monitoring system status. Generally, the training process of simulated space

---

Subsidizing information: human factors engineering research topic SYFD130061803.

---

S. Huan (✉) · B. Wang · W. Lin  
China Astronaut Research and Training Center, Beijing, China  
e-mail: huan\_shang@126.com

flight is participated with three parties jointly, astronauts, instructors, and auxiliary personnel. Astronauts are responsible for flight task operation; instructors and auxiliary personnel guide and assist at the instructor's desk. Simulating the ground guidance, instructor is responsible for the course setting and judgment; auxiliary personnel are responsible for monitoring the system status [1, 2]. Although on the basis of the training control mode of instructor's desk, the task status of simulated space flight is finished, the process occupies too many labor forces, materials, and resources. Thus, the training plan is limited by the factors such as time and personnel; it is not beneficial to the exertion of autonomy of astronauts. Especially while intensive training phase with variant crews, variant subjects, and variant sites, the resources bottleneck is prominent. There are two means to solve the above issues. One means is to simplify simulator to the greatest extent, adopt integrated and virtue technology to make simulators desktop-sized and miniaturization so that the same cost may obtain the most quantity. This means is at the cost of task environment and integral experience, only suitable to the professional skill training of space flight, such as manned rendezvous and docking training. Another means is to adopt advanced interactive control technology to make the core functions of the instructor's desk portable and realize the autonomous training of astronauts. This paper mainly deals with the research of the secondary technological means and expounds the designing and application conditions of hand-held control terminal.

## **47.2 Mobile Interactive Control Terminal Design**

### ***47.2.1 Analysis of Demand***

The main objective of hand-held control terminal (hand-held terminal for short) is to adopt mobile touch screen human-machine interaction way to meet the demand of autonomous training of astronauts. Thus, hand-held terminals shall integrate and optimize the teaching software and systemic monitoring software, cover training course setting, training process control, training replay control, real-time parameter display, systemic status monitor and wireless connection control, and other functions.

### ***47.2.2 Structural Design***

The application environment of hand-held terminal is illustrated as in Fig. 47.1. Astronauts or testees start the hand-held terminal program in the cabin, and connect the simulator server through WiFi wireless network connection, so as to control the simulated program running of server. Lightly touching the touch screen can complete the training course setting, training process control, real-time systemic monitor, and training judgment, completely replacing the operation at the instructor's desk of the instructors and auxiliary personnel.

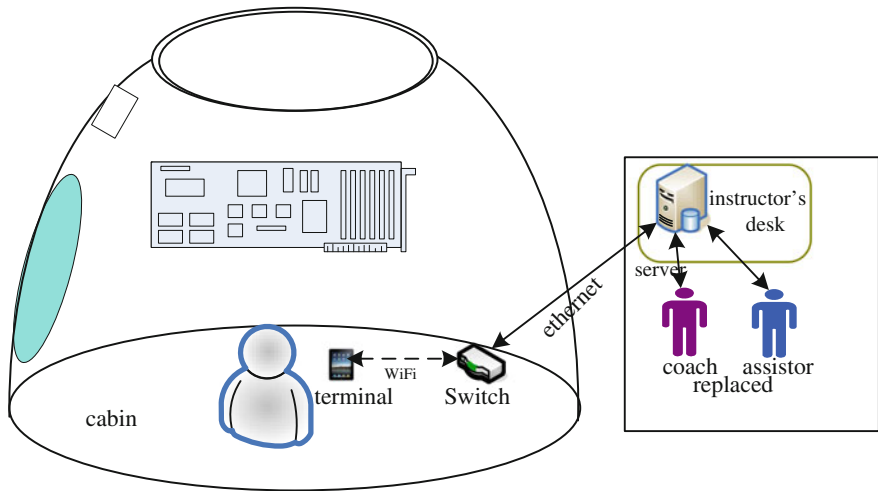


Fig. 47.1 Interactive control of simulator

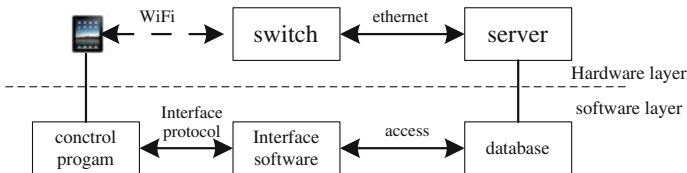


Fig. 47.2 Technology structure of hand-held terminal

Figure 47.2 is the technical framework of hand-held terminal. Hand-held terminal is based on iPad platform development and gives full play the small and exquisite shape of iPad. In order to obtain good network environment, the route of WiFi is placed in the cabin. iPad control program accessing simulator database is realized through the specialized interface software.

### 47.2.3 Interface Software

Interface software is running on the host of simulator system, responding to control program order, accessing database, and transmitting data. It is the professional channel of terminal that the control program accesses server. Interface software makes the database transparent to hand-held terminal, so as to guarantee the safety of database core data under the status of wireless communication. Interface software adopts C++ programming and can run on Windows and Linux operation system. Special design is made for wireless connection and interface protocol.

### 47.2.3.1 Connection Limitation

Interface software establishes TCP server and adopts close control on network connection, only allowing the connection of terminal designated MAC address, IP address, and port number. The connection log is recorded, so as to guarantee the data safety of the server.

### 47.2.3.2 Interface Protocol

In order to optimize the data operation, based on TCP packet, the interface data protocol between the control program and interface software is defined. Transmit data format adopts the form of datagram, including frame header and main body. The frame header includes identifier, message type, message length, and reserved bytes. The data format of main body is defined according to the message type. Avoiding the potential risks of pointer offset operation, the datagram adopts struct type and main body adopts union type to improve the readability and reliability of interface data. The data structure is defined as follows.

```

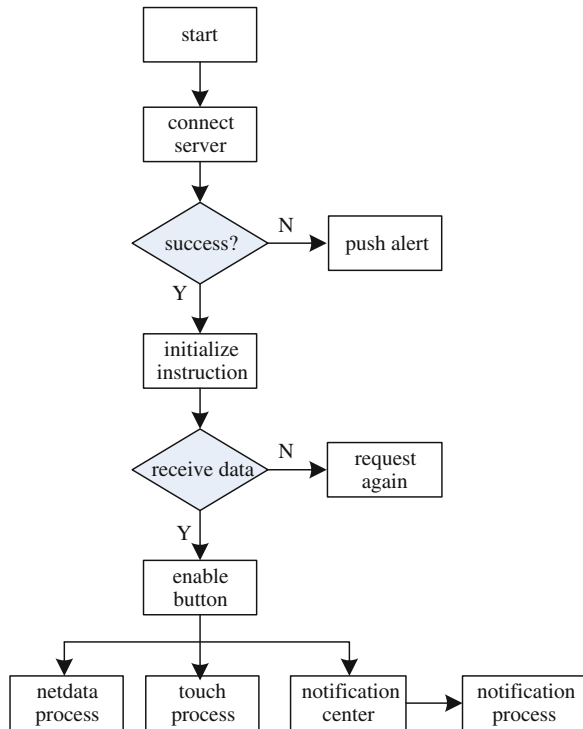
struct Packet
{
    int a; // identifier
    char b; // message type
    unsigned short c; // message length
    int d; // reserved bytes
    union // main body of data
    {
        struct a_packet;
        struct b_packet;
        struct c_packet;
        ...
    }
}

```

### 47.2.4 Control Program

Control program is running on IOS platform, programmed with Objective-C and integrated the core functions of simulators such as instructor's software and monitoring software. It runs through the interface software operating and controlling simulators. Control program also takes charge of the human-machine interactive interface of hand-held terminal, including touch screen operation recognition, data input and display, etc. The program flow refers to Fig. 47.3.

**Fig. 47.3** Design of software process



**47.2.4.1 Interface Design**

According to the human’s operating habits and visual characteristics, the design on interactive interface mainly embodies the perceptual intuition and convenience, avoiding frequent switching pages and increasing the using load. Thus, the control program only provides the two switchable pages of instructors and monitoring. Other elements are controlled within the page. Take the example of page designing of hand-held terminal instructor of rendezvous and docking. The page is divided as connection control area, course setting area, training process control area, training replay control area, and real-time parameter display area from the above to bottom. The buttons and choice boxes are gray while they are prohibited for using, with preset prompt information. If leakage option is existent, then the program pops up prompt information and effectively avoids misoperation and leak operation. Connection control area is set up with default server IP and port number, beneficial for quickly connecting the server (referring to Fig. 47.4).

**47.2.4.2 Interactive Design**

From the perspective of operating habit and efficiency, such as order trigger of program start and pause, generally interaction operation is based on buttons.

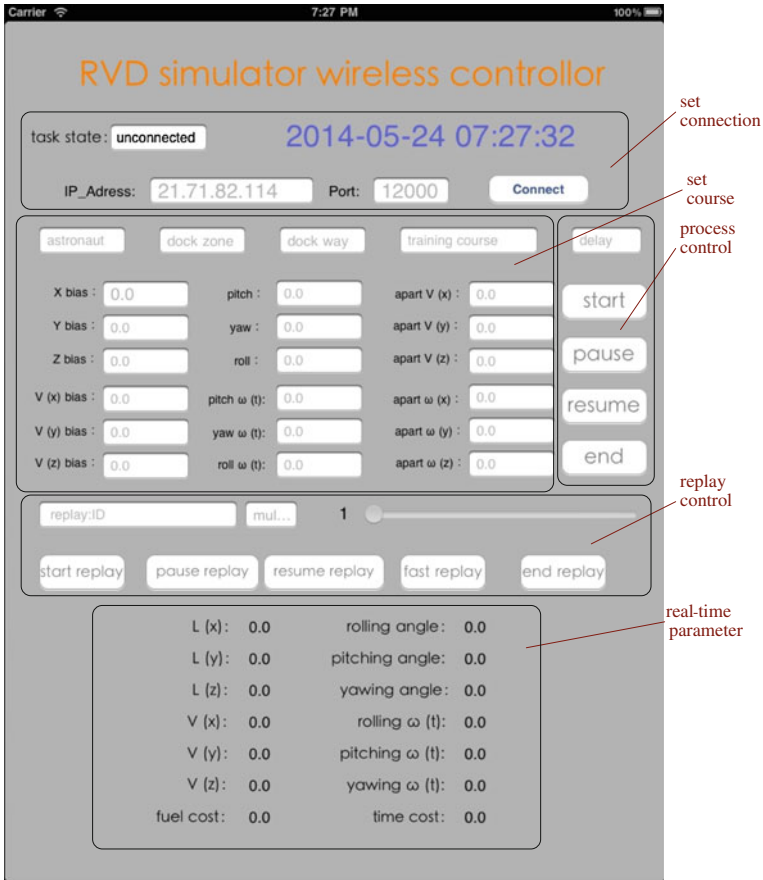


Fig. 47.4 Part of teacher page

The selection items such as course and docking area shall be realized by selecting the pull-down list. Although IOS developer kit does not directly provide pull-down list controls, it can be solved through the self-definition function of Objective-C. Combining with the features of UITextField and UITableView, sealed new DropDown type realizes the function of pull-down list [3, 4]. Under the default status, DropDown type hides UITableView. While UITextField captures TouchEvents, UITableView pops up. After selecting cell, UITextField displays cell content, and UITableView takes back. While considering the usability, consider the interface beautification. Put CGRect type as initialization parameter, DropDown is able to custom the position, size, and pull-down height.



## 47.2.5 Realize the Key Technology

### 47.2.5.1 Object Correlation Technology

Control program has the correlation demand among several objects. The best dealing ways of Objective-C is to adopt NSNotification means. Comparing with delegate, NSNotificationCenter can realize the message delivery between different classes and occupies fewer resources [5]. The control program are widely used NSNotification to correlate objects, enrich the response mode of touch screen, and increase the human-machine interactive experience. Such as, train course is a pull-down list object used for selecting training course. While selecting course trigger orders to inquiry course parameters to the server, interface synchronously responds the corresponding course and parameters to assist the trainees to learn about the difficulties of course. The correlation way is as follows.

```

First step: establish Notification Center
NSNotificationCenter *center= [NSNotificationCenter defaultCenter];

Second step: register monitoring object
[center addObserver:self           //Registering monitors
 selector:@selector(courseChange:) //Calling methods
 name:UITableViewSelectionDidChangeNotification // Type of
notification
 object:trainCourse.tableView]; // monitoring course list view

Third step: deal with notification
-(void) courseChange:(NSNotification *)notification
{
    Send inquiry orders and display parameters.
}

```

### 47.2.5.2 Network Group Package Technology

Based on byte stream reliability requirement, TCP communication is adopted between the control program and interface software. It is related to the technological issues how network data group packages efficiently. Objective-C is the superset of C++ language, possessing the strong data processing functions such as [6, 7] variable array, variable character string, and variable dictionaries. Applying NSMutableData to group TCP packet and abandoning direct pointer offset operation means to identify datastream become simple and efficient. That is illustrated as follows.

```

[netdata appendData:data];      //Add data to global variable netdata
tempLength+=[data length];    //Acquire received TCP packet length
while (1)
{
if (tempLength>=7) {
[netdata getBytes:&packetLength range: NSMakeRange(5, 2)] ;
//Acquire the message length
}
if (tempLength>=packetLength+11)
{ packetFull=1; }          // Received a complete message
if (packetFull)
{Message processing ; }
packetFull=0;
if (tempLength==packetLength+11) //TCP packet equals to data message then
the netdata is reset to zero
{ [netdata resetBytesInRange: NSMakeRange(0, [netdata length])];
[netdata setlength:0];
tempLength=0; }
if (tempLength>packetLength+11) // reset netdata and forward the rest data.
{tempLength-=(packetLength+11);
tempdata=[[NSMutableData alloc] initWithData:[netdata subdataWithRange:
NSMakeRange(packetLength+11, tempLength)] ];
[netdata resetBytesInRange: NSMakeRange(0, [netdata length])];
[netdata setlength:0];
[netdata appendData:tempdata];
[tempdata release];}
}

```

### 47.3 Verification Test

Replace instructor's desk with hand-held terminal; enter into the training pattern of manned rendezvous and docking; test the coverage and usability of hand-held terminal.

### ***47.3.1 Testing Design***

Testing environment: arrange auxiliary personnel, instructors, and astronauts for test, respectively, at the training site of manned rendezvous and docking simulators.

Testing example: randomly select 80 training courses with different difficulties and different phases from database.

### ***47.3.2 Testing Results***

The testing results from the three groups of personnel, auxiliary personnel, instructors, and astronauts indicate that hand-held terminal has possessed friendly interactive interface, convenient operation, and complete functions. It is the same as the instructor's desk in terms of course selection (including self-definition of parameters), process control, playback control, and real-time supervision of parameters. The mobile interactive control mode of simulator uses flexibly, which does not affect the training operation of astronauts and meet the autonomous demand.

## **47.4 Conclusions and Prospect**

Under the circumstance of not changing the internal cabin technological status, hand-held terminal expands the human-machine interactive mode of simulators. Without the assistance of instructors and auxiliaries, lightly touching the iPad touch screen within the cabin can complete autonomous training. During the training period, the course can be arranged autonomously. Voluntary judgment of training effect improves the autonomy of training and saves the training guaranteeing resources. The hand-held terminal belongs to touch-control interaction. Developing voice recognition, realizing voice control interaction, and further lessening the using load are the trend of the next step development. The interactive control mode can be popularized to other control field of large equipment.

## **References**

1. Chao JG, Chen SG (2008) Study on technology of space flight training simulator and Its engineering implementation. *Space Med Med Eng* 21(3):233–239
2. Huan S, Deng H (2011) Design and implementation of the interface system for a space flight training-simulator based on CAN bus. *Space Med Med Eng* 24(5):361–365
3. Davidson JD (2008) *Learning Cocoa with objective-C*. China Electric Power Press, Beijing

4. Mark D, Nutting J, LaMarche J (2012) Beginning IOS 5 development. Post& Telecom Press, Beijing
5. Guan DS (2013) IOS developing insights: network and iCloud. Higher Education Press, Beijing
6. Kochan SG (2011) Programming in objective-C2.0. China Machine Press, Beijing
7. Lee WM (2010) Beginning iPad application development. Wiley Publishing, Inc., Canada

# Chapter 48

## Modeling and Simulation in Rendezvous and Docking Spaceflight Training

Baozhi Wang

**Abstract** *Purpose* Setting Chinese “SHENZHOU” manned spacecraft and “TIANGONG” sky laboratory as the simulation objects, the study of modeling and simulation of rendezvous and docking (RVD) spaceflight training is carried on. In order to provide the training environment, the simulated training facilities of spaceflight man–machine–environment (MME) were developed. *Method* the training models were set up, which are based on the engineering models and the training requirements and directed by simulation theory, such as similarity theory, fidelity, and transfer of training. *Results* the simulation of data information and their interaction of GNC, instruments, environment control, and other subsystems have been accomplished, and the simulation of RVD TV imagine has been accomplished. *Conclusion* The M&S of RVD spaceflight training is credible by means of the RVD spaceflight validation. The outlooks of application of simulation theory and new technologies in training simulator in the future were also analyzed in this paper.

**Keywords** Rendezvous and docking · Spaceflight training · M&S · Spaceflight training simulator

### 48.1 Introduction

To provide rendezvous and docking (RVD) spaceflight training simulator for the astronaut, the study of modeling and simulation of RVD spaceflight training has developed and the research result has been successfully applied in the RVD spaceflight training of our country. The RVD spaceflight training simulator (hereinafter referred as to the simulator) of our country is the spaceflight training

---

B. Wang (✉)

National Key Laboratory of Human Factors Engineering, China Astronaut Research and Training Center, Mailbox: 5132, Beijing 100193, China  
e-mail: w\_bz126@126.com

simulation system [1–4] for the astronaut which targets the manned spaceflights of “SHENZHOU” manned spacecraft and “TIANGONG” sky laboratory, etc. as the simulation objects. The simulator herein refers to the manned spaceflight simulator and complex training simulator researched and developed during the space RVD task period of our country. The core problem to research and develop the simulator is to establish the mathematical model of the spacecraft subsystem to output the simulation data through model resolving for the data users (for the working principle of the simulator and the processing procedure of the simulation data, please refer to [2] and shall not be explained here) of simulator instrument displaying, instructor monitoring, visual simulation and sound simulation, etc., so the mathematical model shall reflect the simulation object working principle of the spacecraft, namely the simulation data being kept consistent with the working status information of the real equipment [1]. But, in accordance with transport theory [5], as the training simulator, it is only required meeting the training requirement, since certain of difference between the simulation model including the mathematical model and real spacecraft shall not influence the training result [6], so the mathematical modeling of the simulator can simplify the engineering model in accordance with the principle of data equivalence and information processing similarity. Based on the deep understanding and accurate grasp of subsystem working discipline, with sufficient information reflected, the simplifying can improve the model resolving efficiency, decrease the complexity of software programming, and reduce the costs of system debugging and maintaining. Therefore, the method has important significant to be researched, optimized and refereed, as well as applied and promoted in the research and development of the subsequent simulator of space station mission, etc., and it is the target of the paper herein to summarize the modeling method of RVD training simulator.

## 48.2 Method and Result

### 48.2.1 *GNC Modeling and Simulation*

Take “SHENZHOU” manned spacecraft as the example, GNC data information interactive model is established in accordance with GNC system constitution and working principle [7] and through combining and simplifying the component of constitution and abstraction of information input and output relations, please refer to Fig. 48.1. Application module and dynamics simulation module are main parts of GNC function, as the spacecraft simulation module as actualized the other subsystem simulation of the spacecraft data management, etc., and the interface control software is the data interface between the software of simulator simulation software, instructor training control software, and bunker equipment collecting information, etc.; the dynamics simulation module has established the mathematical model of each measurement sensor of the spacecraft and mathematical

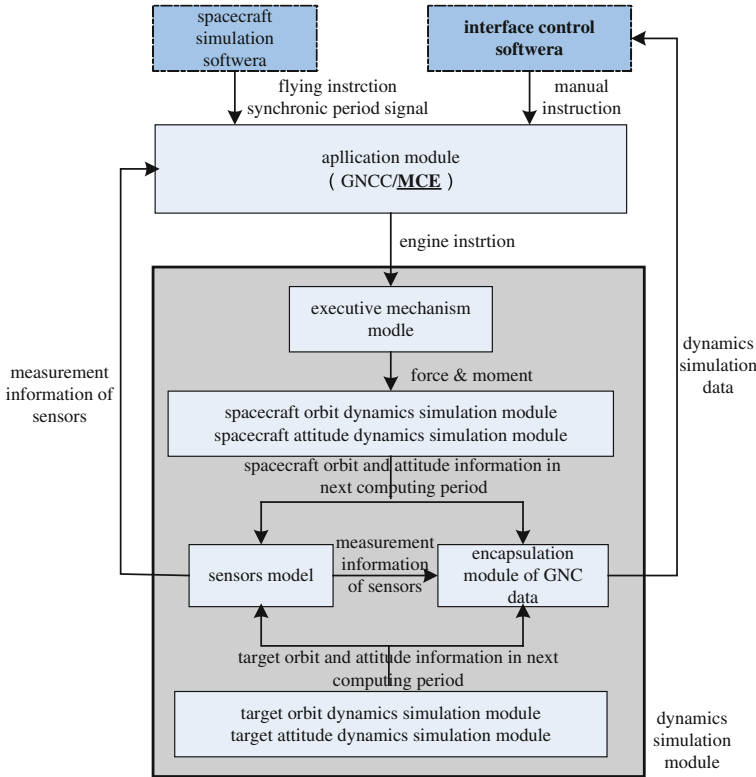


Fig. 48.1 GNC data interaction model

model of the executing component which can actualize the targeted aircraft orbit and attitude dynamics simulation, spacecraft orbit and attitude dynamics simulation and complex attitude, and orbit dynamics simulation; the application module has actualized spacecraft GNC computer GNCC and manual line MCE control algorithms computation. GNC simulation data shall be sent to interface control software after packed in accordance with communication protocol and then send to network through UDP multicast for the simulator data user to use.

The orbit dynamics model includes the earth core inertial spacecraft orbit dynamics equation and target aircraft orbit dynamics equation. The training modeling shall only consider the non-spherical perturbation of the earth and the dynamics equation of tracking aircraft, and target aircraft shall be the same, please see formula (48.1). In the formula,  $X$ ,  $Y$ , and  $Z$  refer to the spacecraft positions,  $V_X$ ,  $V_Y$ , and  $V_Z$  refer to the spacecraft speed,  $J$  refers to the main spherical harmonics of the earth second order,  $r$  refers to  $\sqrt{X^2 + Y^2 + Z^2}$ ,  $a_e$  refers to the equatorial radius of the earth,  $F_X$ ,  $F_Y$ , and  $V_Z$  refer to the engine thrust (0 for no thrust imposed), and  $M$  refers to the quality of single spacecraft (or complex). The attitude dynamics module includes the manned spacecraft attitude dynamics equation and target

aircraft attitude dynamics equation under the earth core inertial. The attitude dynamics equations of the tracking aircraft and the target aircraft are the same, please see formula (48.2). In the formula,  $J_x$ ,  $J_y$ , and  $J_z$  refer to the triaxial rotational inertial;  $\omega_x$ ,  $\omega_y$ , and  $\omega_z$  refer to the projection of the aircraft rotation angular velocity on the aircraft coordinate system triaxial;  $M_x$ ,  $M_y$ , and  $M_z$  refer to the projection of the applied moment on the aircraft coordinate system triaxial.

$$\begin{cases} \dot{X} = V_x \\ \dot{Y} = V_Y \\ \dot{Z} = V_Z \\ \dot{V}_X = -\mu \frac{X}{r^3} P(Z, r) + \frac{F_x}{M} \\ \dot{V}_Y = -\mu \frac{Y}{r^3} P(Z, r) + \frac{F_Y}{M} \\ \dot{V}_Z = -\mu \frac{Z}{r^3} P(Z, r) + \frac{F_Z}{M} \end{cases} \quad (48.1)$$

$$P(Z, r) = \left\{ 1 + \frac{3}{2} J \left( \frac{a_e}{r} \right)^2 \left[ 1 - 5 \left( \frac{Z}{r} \right)^2 \right] \right\}$$

$$\begin{cases} J_x \dot{\omega}_x + (J_z - J_y) \omega_z \omega_y = M_x \\ J_y \dot{\omega}_y + (J_x - J_z) \omega_x \omega_z = M_y \\ J_z \dot{\omega}_z + (J_y - J_x) \omega_y \omega_x = M_z \end{cases} \quad (48.2)$$

The relative orbit dynamics model in the tracker and target spacecraft orbit coordinate system has not been established in the training simulator. The relative positions information simulation of the tracker and target spacecraft shall be computed through position phasor difference of the two aircrafts under inertial. The attitude parameter simulation shall be, respectively, solved to the tracker and target aircraft coordinate system attitude matrix  $A_1$  and  $A_2$  under inertial, and then to the attitude angle of the two aircrafts. The relative attitude dynamics model in the tracker and target aircraft orbit coordinate system has not been established in the training simulator. The relative attitude parameter simulation of the tracker and target aircraft shall be solved through dot product  $A$  of  $A_1$  and  $A_2$ , and then the relative attitude angle of the two aircrafts can be solved. The specific arithmetic is as followed: based on the spacecraft coordinate system, the relative position is demonstrated under J2000 inertial as  $\Delta \vec{R}_C^T = \vec{R}_T - \vec{R}_C$ , in the formula:  $\vec{R}_T$  refers to the position vector of the target aircraft and  $\vec{R}_C$  refers to the position vector of the spacecraft. The relative position of the spacecraft:  $\Delta \vec{R}_R = R_1(\varphi_T) R_2(\theta_T) R_3(\psi_T) \Delta \vec{R}_C^T$ ,  $R_i$  refers to the rotation matrix. For the attitude matrix description about the relative matrix from the aircraft coordinate system to the target coordinate system, please see formula (48.3), and the solved relative attitude angles are  $\Delta \psi = \arctan(A_{12}/A_{11})$ ,  $\Delta \theta = \arccos(-A_{13})$  and  $\Delta \varphi = \arctan(A_{23}/A_{33})$ .



$$A_R^T = A_2 A_1^T = \begin{bmatrix} A_{11} & A_{12} & A_{13} \\ A_{21} & A_{22} & A_{23} \\ A_{31} & A_{32} & A_{33} \end{bmatrix} \quad (48.3)$$

$$\begin{cases} \ddot{\rho} - \rho\dot{\gamma}^2 = a_x \\ \rho\dot{\gamma} + 2\gamma\dot{\rho} = a_y \end{cases} \quad (48.4)$$

When the distance between the two aircrafts is within one hundred meters, the gravitation difference of the earth imposed on the two spacecrafts, and the relative motion equation can be simplified as formula (48.4). In the formula,  $\rho$  refers to the sight distance,  $\gamma$  refers to the sight rotation speed, and  $a_x$  and  $a_y$  refer to the accelerated speed of each axis of the sight coordinate system.

### 48.2.2 Docking Component Model

The docking preparation is the mechanical motion process pushed by docking ring and pulling back process if the inverse process. For the relations between the distance from the docking ring current position to the supposed docking position  $L_1$  and sensor voltage value  $D_1$  and the relations between  $L_1$  and docking ring motion time  $t_1$ , please see formula (48.5); for the relations between the docking ring extreme position distance  $L_2$  and sensor voltage value  $D_2$  and  $L_2$  and docking ring motion time  $t_2$ , please see formula (48.6); for the relations between the docking ring closure angle  $\theta$  and angular displacement sensor voltage measurement value  $D_3$  and angular displacement time  $t_3$ , please see formula (48.7).

$$L_1 = \frac{a_1(D_1 - b_1)}{c_1}, \quad t_1 = \frac{L_1}{d_1} \quad (48.5)$$

$$L_2 = \frac{a_2(D_2 - b_2)}{c_2}, \quad t_2 = \frac{L_2}{d_2} \quad (48.6)$$

$$\theta = a_3 D_3 - b_3, \quad t_3 = \frac{\theta - b_4}{d_3} \quad (48.7)$$

### 48.2.3 Environment Control Model

In accordance with the principle of data equivalence and information processing similarity, for the simulator, the manned spacecraft simulator and complex simulator environment control and life support subsystem training model has been established and actualized the simulation [8] of total pressure of cabin air, oxygen partial pressure, carbon dioxide partial pressure, temperature, and humidity. It shall mention that the RVD simulator has established fine-grained individual

**Table 48.1** Simulation models of gas supply and adjust subsystem

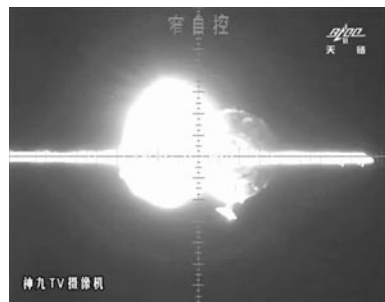
Layer of model	Name of model
Individual model layer	Cabin, cylinder, oxygen cylinder, high-pressure solenoid valve, pressure relief valve, valve, gas supply unit, oxygen supply unit, gas exhaust, and pressure control unit
Inner relationship layer	Pipeline connection, cabin pressure varying relationship, cylinder pressure varying relationship
Control layer	Auto control mode, manual control mode, command control mode, cabin pressure balance mode

equipment and subsystem model and improved the model resolution; it has adopted object-oriented simulation design mode and improved the model reusability; it has adopted the module laying design idea to divide the model as independent model layer, internal relation layer, and control layer. Take the air supply and pressure regulation subsystem as the example, for the model and layering, please see Table 48.1.

#### 48.2.4 Television Image Simulation

For RVD of aircraft with target through manually controlling, the astronaut shall judge the relative motion state of the two aircrafts in accordance with the object target image shoot by television camera. As the illumination variation on orbit and object reflection influence, there are two typical cases may cause the image failing to be identified: (1) As the light saturation, the target image is white space (see Fig. 48.2); (2) As the light under-saturation, the image is dark. These two cases shall disturb the astronaut's judgement. Through the dimming function of camera, ensure clear image. To actualize the light saturation, under-saturation and dimming function simulation of the simulator television image simulation, the main method is high-dynamic-range imaging, special effect rendering, brightness adjustment, and tone mapping.

**Fig. 48.2** Target image in saturation



### 48.2.4.1 Image Light Saturation Result Simulation

The light saturation image simulation adopts the high-dynamic-range-imaging and special effect rendering methods. To solve the typical problem of low rendering brightness, create a light map in floating point format for each view in the scene, and each pixel of the map represents the corresponding position light intensity of the view. Apply Frame Buffer Object (FBO) of Open GL to render the bound floating point light map view in the floating point texture of same size with the screen to improve the pixel brightness contrast. Give consideration to the training simulation simplifying and real-time performance and adopt floating point texture of GL\_RGBA16F mode to reach higher accuracy with larger range. The light brightness of each pixel point shall be obtained [8, 9] through the formula (48.8). Adopt high-pass filtering for the highlighted part in floating point texture, make statistics of the brightness value of each pixel of the original image, reserve pixel point of the brightness value  $L_w$  higher than high-pass valve value, carry on horizontal and longitudinal Gaussian mixture after the filtered image compressed by ratio, and finally blend with the original image to form the saturation special effect (see Fig. 48.3).

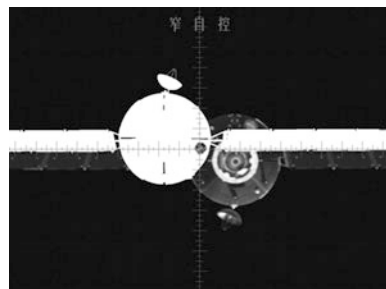
$$L_w = 0.299R + 0.587G + 0.114B \tag{48.8}$$

$$C_a = \begin{cases} \bar{L}_{\min}/\bar{L}_w, & \text{if } \bar{L}_w > \bar{L}_{\max} \\ 1, & \text{if } \bar{L}_{\min} \leq \bar{L}_w \leq \bar{L}_{\max} \\ \bar{L}_{\max}/\bar{L}_w, & \text{if } \bar{L}_w < \bar{L}_{\min} \end{cases} \tag{48.9}$$

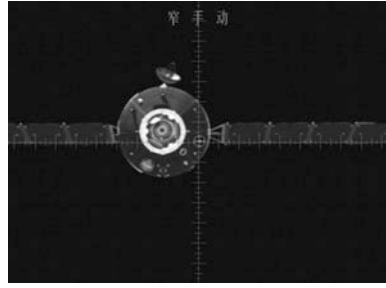
### 48.2.4.2 Image Dimming Result Simulation

Generally, the camera dimming strategy is to set average gray-level result is  $L_w$ . When  $L_w$  gray-level value is within  $[L_{\min}, L_{\max}]$ , it shows that the current luminance is suitable without requiring dimming; if  $L_w > L_{\max}$ , adjust the electronic shutter to adjust the average brightness to  $L_{\min}$ ; if  $L_w < L_{\max}$ , adjust the electronic shutter to adjust the average brightness to  $L_w > L_{\max}$  [8]. For television image

**Fig. 48.3** Saturation image simulation



**Fig. 48.4** Light adjustment simulation



simulation, adopt the average brightness as reference and compare maximum value  $\bar{L}_{\max}$  with minimum value  $\bar{L}_{\min}$  regulated through average brightness value and dimming strategy to confirm the dimming coefficient  $C_a$ . For the dimming simulation arithmetic, please see formula (48.9); for adjusting the saturation image to normal image simulation effect, please see Fig. 48.4 [9].

### 48.3 Conclusion and Outlook

The RVD spaceflight training model and simulation actualization process introduced herein is verified credible through the space flight operation of the astronaut with RVD task, and the training result is effective. It now seems that the space station task simulation training of our country in the future has broken the single astronaut program and equipment caring operation training scope on individual simulator and new demand of collaborative training has occurred among the simulators on the basis of man–man collaboration and man–machine collaboration, so, the granularity and interaction of several spacecraft models shall be designed again, and it needs to innovate based on the modeling method of training model, break data equivalence modeling, carry on refining model granularity, and support new training projects; secondly, the collaborative training among the simulators put new requirement forward to training control program, so, it needs to innovate the simulation computation mode, research, and apply Web/cloud simulation technology and innovative simulator simulation software architecture (SSA) to design development technology to meet the real-time and distribution performance requirement at the same time; thirdly, to increase the training items outboard in space station, it needs to research cabin microgravity conditions and training simulation technology under space environment outboard and visual reality (VR) simulation new technology of applied physics system simulation, stereo display and natural phenomenon modeling and simulation, etc. to improve fidelity and practicality of VR training simulator; last, research applied simulator VVA theory, method, and tool to improve the simulator credibility of space station.

## References

1. Wang B et al (2011) The study on creditability conception of flight training simulator (FTS). In: System simulation technology and application, vol 13. Scientific Research Publishing, USA, pp 681–686
2. XUE L (2005) Spaceflight training simulation technology. National defence industry press, pp 1–49
3. Xue L, Chen S, Chang T et al (2005) The fixed base full mission spaceflight training simulator. Space Med Med Eng 16(suppl):527–531
4. Chao J, Chen S, Xue L et al (2008) The study on spaceflight training simulator technology and engineering. Space Med Med Eng 21(3):133–239
5. Cai X (2008) Review of 15 kinds of learning transfer theories. China Educ Innov Herald 35:83–85
6. Wang Q, Jiang W, Liu D (2012) Analysis on relationship between flight simulation fidelity and transfer of training. Space Med Med Eng 23(4):304–308
7. Qi F (2003) Manned spacecraft technology. National defence industry press, pp 258–260
8. Wang J, Wang P et al (2012) Research on modeling method of MSTs environment control and life support system training simulation. In: System simulation technology and application, vol 14. Scientific Research Publishing, USA, pp 10–11
9. Chao J, Wang J et al (2014) TV images simulation of rendezvous and docking for astronauts' training. Manned Space 4:11–14

# Chapter 49

## The Research of Vehicle Dynamics Modeling and Real-Time Simulation Technique Based on Vortex

Fang Xie, Zhong Zheng, Sijuan Zheng, Zhongliang Wei and Qun Wang

**Abstract** The Vehicle man-machine environment simulator is a professional testing simulation system that specifically for man-machine environment engineering's research. The simulation platform mainly simulates the vehicle's bumpy, vibration and shock caused by driving and manipulation on the various typical road surfaces, it provides a realistic motion environment for man-in-the-loop simulation. Vortex dynamics simulation software is an important tool to complete real-time dynamics calculation of the man-machine environmental simulator. The paper first briefly introduces the multi-body dynamics simulation software Vortex and then introduces the vehicle dynamics modeling approaches based on Vortex. Vehicle dynamics real-time simulation experiments are completed by setting up contact properties between vehicles and the ground. Results show that the Vortex has higher accuracy and good real time in the dynamics calculation.

**Keywords** Vortex · Vehicle · Dynamics · Real-time simulation

### 49.1 Introduction

The vehicles' man-machine environment simulator is specially engaged in the man-machine environment system engineering research. The simulator research analyzes and evaluates the general performance and crew work efficiency by simulating the vehicles' driving state of roads, the cabin, and vibration noise environment, coordinates technical specifications of various subsystems, and enables the vehicles' overall performance to achieve the optimum condition. The simulation experiment platform mainly aims at the simulation of jolt, impact, and buffeting statuses, which are caused by vehicles driving and manipulating on

---

F. Xie (✉) · Z. Zheng · S. Zheng · Z. Wei · Q. Wang  
China North Vehicle Research Institute, Beijing, China  
e-mail: christie\_xie@163.com

various typical road face, providing the researchers with vivid movement environment of persons in the loop.

The man-machine environment simulator mainly consists of the real-time simulation computer system, the scenery system, simulation cabin, movement system, sound simulation system, and control system. Among them, the real-time simulation computer system is the core of the simulator system, which contains many modules, such as the real-time management module, the vehicles' dynamics simulation module, the terrain matching module, the actual combat simulation module as well as various subsystems simulation module. Real-time management module realizes dispatch and data transmission among various subsystems, receives manipulation variables from the simulation cabin, and sets information on vehicles, road condition, terrain and battlefield environment, etc., from the experimental control console. After real-time resolving, the real-time management module outputs vehicles' positions, posture and movement parameters, etc., information to the scenery system, instrument indicator of the simulation cabin, movement system, sound simulation system, and experimental control console.

The important tool to carry on dynamics resolving in the real-time simulation computer system is the Vortex dynamics simulation software. Vortex is specially used in the exact dynamics modeling and real-time simulation for realistic physical systems, such as ground vehicles, water surface or submarine aircraft, fixed wing or rotorcraft, robot, sea detector, spatial manipulator, and large-scale mechanical device. Compared with other multi-body dynamics software, such as ADAMS [1], AMEsim, RecurDyn, etc. Its biggest advantages are the fast and stable collision examination as well as dynamics resolving.

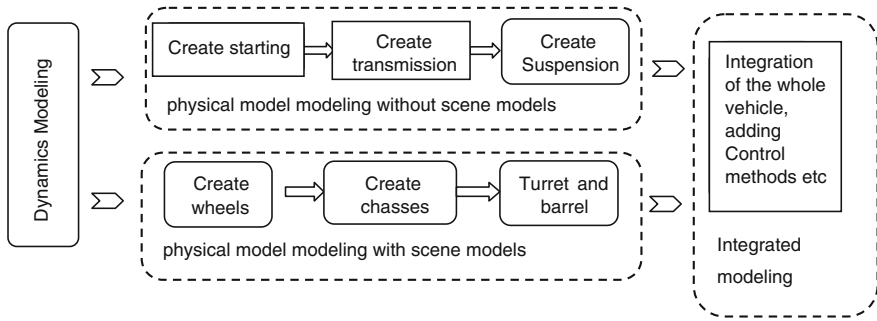
Vortex has used the open API function structure and may insert MATLAB/SIMULINK procedure into the Vortex application procedure frame, as well as realize real-time simulation of the complex mechanical and electrical control system. MATLAB/SIMULINK control system may be added for the vehicles, thus realize dynamics modeling and real-time simulation for electrical transmission-type vehicles.

## 49.2 Vehicles Dynamics Modeling

The vehicles models are divided into the physical models and the scenery models; the former are used to make dynamics, and the latter mainly realize vivid feeling in the visual sense. In this paper, the vehicles' dynamics modeling refers to build vehicles' physical models.

The Vortex software has provided dynamics models for the vehicles' all modules, such as engine input and output model, power transmission model, suspension model, wheel and ground coupling model, and so on. The entire vehicles' dynamics modeling is the procedure that first models for each module and then integrates all of them.

The entire vehicles' dynamics modeling may be divided into several different types: physical modeling without scene models, physical modeling with scene



**Fig. 49.1** Vehicle dynamics modeling process

models, and modeling of the entire vehicle control system. The first kind of types include the engine, power transmission, and suspension spring damping system; they can carry on dynamics resolving in the interior according to the established parameters and output the correct responding results, and these are a kind of physical models, which are not obvious to users. The second kind includes vehicles' chassis, wheels, and gun tube turret, which are physical models obvious to the users. The third kind is integration of each module to build the entire vehicle and adds control system.

Process of the vehicles' dynamics modeling is shown in Fig. 49.1.

### 49.2.1 Create Vehicles Physical Model

The above-mentioned physical model is of the second kind, including vehicles chassis, wheel, and turret parts. This process creates shape, material, and quality for all parts.

- Vortex provides users with nine different types, so that the users can create their needed shapes. Among them, the most simple mode to create vehicles chassis is to use box (to create cuboid), and the chassis created like this is a cuboid. It also may be created by using ConvexMesh (create complex geometric solid which is composed by a series of points), the complex geometric solid can be created by a series of points according to the chassis shape. The wheel can be created by using cylinder (create circular cylinder); then, wheels can be simplified as a circular cylinder. Tire models corresponding to the wheel will be introduced in the following.

### 49.2.2 Create Vehicles' Dynamics Properties

After creating the vehicles physical model, vehicles need to increase dynamics properties, including vehicles' engine, power transmission, and wheel suspension, which is the first type described before.



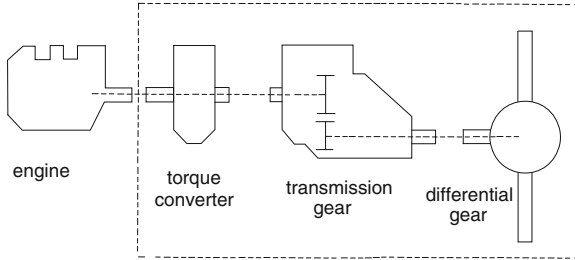


Fig. 49.2 Engine and power train connection diagram

### 49.2.2.1 Engines and Power Transmission

The engine is the source of vehicles’ dynamics, and the power transmission system distributes the engine speed to each wheel according to certain proportion, to realize the vehicles’ movement.

In the Vortex’s VxVehicle module, it has provided some vehicles’ models, including the simple vehicles, the wheeled vehicles, the rigid tracklaying vehicles, and the flexible tracklaying vehicle model; users also may create their own vehicles’ models.

Each kind of vehicles’ model has provided users with the default engine model, the gear box model and the differential gear model, and its connection composition is shown in Fig. 49.2.

Vortex provides a default relation among the engine torque, the throttle opening, and the rotational speed, as shown in Fig. 49.3.

Control the throttle opening, Vortex can control the engine to output different rotational speed and torque, which can be output by the gear box after choosing different gear. Finally, speed is assigned to each wheel by the differential gear, and drive wheels to move, and carry on dynamics simulation.

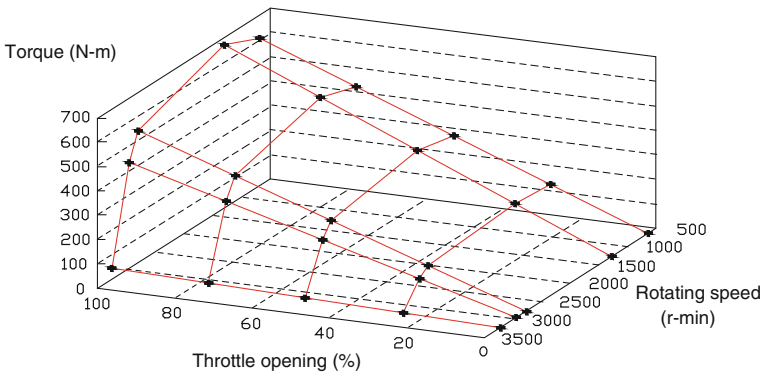
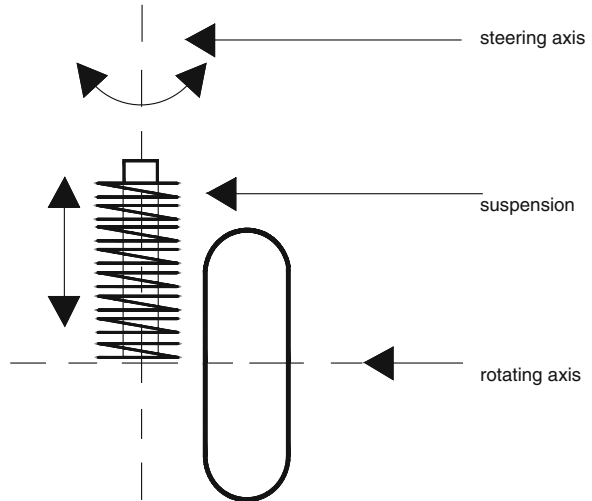


Fig. 49.3 Relation among torque, throttle opening, and rotating speed

**Fig. 49.4** Models of wheels and suspensions



#### 49.2.2.2 Wheel and Suspension

Vortex provides the users with tire and suspension models, and its structures are shown in Fig. 49.4.

Where there are four kinds of tire models: (1) the magic formula tire model, based on Pacejka theory; (2) the composite slip tire model, based on Szostak theory; (3) The Fiala tire model, based on Fiala theory; (4) The soft terrain tire model, based on Bekker and Wong theory. A lot of papers have published based on the above theories [2–5], and users can choose specific models to create wheels and do simulation.

In the suspension models, suspension stiffness and damping can be set based on the spring-damper system model, and Vortex can fit nonlinear stiffness and damping curve, so that simulation suspension dynamics is more realistic.

#### 49.2.3 Create a Complete Vehicle

Through the above description, dynamic modeling of all vehicle parts, including engine, transmission, wheel, suspension, and other parts, have been completed; then, various parts have to be assembled together to form a complete vehicle with dynamic properties.

Chassis is the core of a vehicle; all the parts are assembled in chassis according to their locations, wheels are assembled in chassis through the suspension, turret fixed in chassis through the hinges' constraints, and finally, vehicle dynamics simulation can be done by adding ground.

### 49.3 Set Touch Properties Between the Vehicle and Ground Surface

As described on, vehicle dynamics models have been established, but if only vehicle models are not enough, the vehicle must be placed on the terrain, to make a real-time simulation of vehicle dynamics. When the vehicles drive in a different terrain (such as cement, sand, and grass), they reflect different dynamics properties, because vehicles have different contact properties with different ground materials.

So, in order to truly make dynamic simulation, contact properties must be set for the vehicle and the ground, mainly including vehicles, terrain materials, and their contact properties.

For vehicles, parts can be specified the needed material for vehicles created in Sect. 1.1, such as wheels and body material. To terrain, specific areas can be designated as required ground, such as cement, sand, and grass.

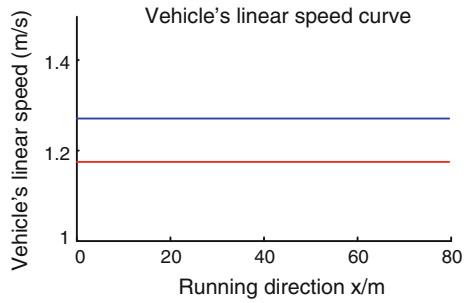
After specify the material, different contact properties can be set for vehicles when they contact with different grounds, to simulate the dynamics of the vehicle when they drive on different grounds. Because vehicle terra mechanics is certainly very complex, setting the contact property is not enough, and some simplifications are made here. Contact properties set here mainly include the following: (1) contact surface friction type; (2) contact surface friction model; (3) contact surface friction coefficient; (4) recovery coefficient, which denotes coefficient for impulse converting into kinetic energy when contact; (5) soft degree of the contact surfaces, which has relations with damping; (6) damping, which has relations with soft degrees of contact surface; and (7) contact surface steering coefficient, which makes vehicles to steer, and it may cause excessive or insufficient steering.

### 49.4 Dynamic Real-Time Simulation

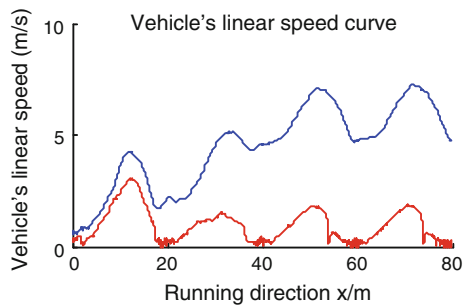
Before the dynamic simulation, we should use 3D modeling software to create traffic scenarios models to obtain visual effects, and import these models into the Vortex and link them with corresponding physical models, then calculate the vehicle dynamics through the Vortex physics engine. It creates two roads including one flat road and one sinusoidal road for vehicle dynamics simulation, the sinusoidal road's wavelength is 20 m and it's amplitude is 1m. One of the road is set as cement and the other is sand road, then do the simulation.

During the simulation, Vehicles are driving along the X direction. The cranks are locked when the speed reaches 1,500 rpm, and then the simulation respectively records the z coordinate of the vehicles' mass center from 0 to 80 m section, the vehicles' linear speed and acceleration. Graphs are drawn through MATLAB, vehicles' linear speed curve drawings are shown in Figs. 49.5 and 49.6. The blue curve denotes driving in the cement road, and the red one represents driving in sandy road.

**Fig. 49.5** Linear speed curves of vehicles in the horizontal road



**Fig. 49.6** Linear speed of vehicles in the sinusoidal road



Results of the simulation show that in the same experimental conditions, (1) the dip of vehicles in the sandy road is larger than that of cement road; (2) linear speed of vehicles in the sandy road is smaller than that of cement road; (3) in the condition that rotating speed of cranks of the vehicle engine keep constant, when vehicles drive in the flat road, the acceleration is zero; and (4) when the rotating speed of the cranks of the vehicle engine keeps constant, vehicles drive more difficult in the sandy road with a sinusoidal shape than in the cement road, its speed being in the gradually decreasing trend, which is consistent with the real situation.

### 49.5 Conclusion

This paper introduces vehicle dynamics modeling based on Vortex software and does real-time simulation. The results show that the Vortex's vehicle dynamics modeling can reflect the dynamics characteristics of the vehicle when driving, with higher accuracy and strong real time. Therefore, Vortex will have a wide application in vehicle dynamics simulation; Vortex will also provided the conditions for subsequent researches through real-time vehicle position and attitude solution, velocity, acceleration, and other data-driven platform with six degrees of freedom.

## References

1. Chen LP (2005) Mechanical system dynamics analysis and ADAMS application tutorial. Tsinghua University Press, Beijing
2. H.B. Pacejka. (1996) The tyre as a vehicle component. XXVI FISITA Congress Prague
3. Fiala E (1954) Seitenkrafte am rollenden Luftreifen. VDI-Zeitschrift 96:973
4. Bekker MG (1969) Introduction to terrain-vehicle systems. The University of Michigan Press, MI, Ann Arbor
5. Wong JY (2001) Theory of ground vehicles, 3rd edn. Wiley, New York

**Part VIII**  
**Theory and Application Research**

# Chapter 50

## Evidence-Based Ergonomics and Application in Manned Space Flight

Hong Liang, Zhijun Xiao, Jianhui Li, Guohua Jiang, Hong Qi,  
Yongjie Ma, Ping Liao and Yumei Zhang

**Abstract** This paper includes three chapters. Chapter 1 introduces the concept of evidence-based ergonomics (EBE) and the relationship between evidence-based medicine (EBM) and EBE. Chapter 2 shows the framework of EBE model composed of six levels based on four requirements of human factors and ergonomics science (HFES). Chapter 3 collects the application instances of EBE in manned space flight, containing space human factors engineering (SHFE) project plan (JSC 29022 Rev A), Space human factors engineering gap analysis project final report (NASA/TP-2007-213739), Human health and performance risks of space exploration missions (NASA/SP-2009-3405), 2011 Space Human Factors Engineering Standing Review Panel (SRP) Evidence Review Final Report, Evidence Report: Risk of Inadequate Critical Task design (2013).

**Keywords** Evidence-based ergonomics (EBE) · Evidence-based medicine (EBM) · Human factors and ergonomics science (HFES) · Space human factors engineering (SHFE) · Standing review panel (SRP)

### 50.1 Introduction

The rise of evidence-based medicine (EBM) patient centered and medicine evidence based in twentieth century 90s has got rapid development. Entered in twenty-first century, evidence-based ergonomics (EBE) operator centered and ergonomics evidence based has been created.

---

Funding information: China manned space flight project fund.

---

H. Liang (✉) · Z. Xiao · J. Li · G. Jiang · Y. Ma · P. Liao · Y. Zhang  
China Astronaut Research and Training Center, Beijing, China  
e-mail: 1302715079@qq.com

H. Qi  
China Manned Space Agency, Beijing, China

The foundation of EBE is ergonomics, named human factors engineering. EBE is a young discipline after the two World War and mainly studies human performance and security in man-machine environment system. Founding of EBE is the result of creative development that is the essence of evidence-based medicine into the ergonomics. The practice of evidence-based ergonomics is obtaining ergonomics data through the systematic collection, screening, using experimentally measured, efficiency, system review. EBE services to enhance human work ability and health level of security.

The common point of EBE and EBM is to solve their own problems based on the same basic elements. Element one is clearly to define the question demanded for answer, two is to collect evidences for answering questions, three is to identify the evidences collected, four is to integrate evidences and the object of interest factors so as to improve the decision, and five is to evaluate the whole process for future improvement. Different point of EBE and EBM is who is concerned, the former is the operator without disease and the latter concerned the patient with disease [1, 2].

## **50.2 System of EBE**

### ***50.2.1 Contents and Feature of EBE***

Developing of EBE based on ergonomics, similar with ergonomics, mainly includes three aspects that are evidence-based physical ergonomics and evidence-based mental ergonomics and evidence-based organization ergonomics.

The basic characteristics of EBE based on ergonomics is a result of the four basic requirements, and the efficiency of science is based on multidisciplinary requirements (multidisciplinary), validity requirements (validity), degree of plasticity requirement (flexibility), multi-purpose (research and application use), etc. In other words, feature of EBE is to meet the needs of researchers, engineers, and users, and to ensure and enhance the ability of the operator.

### ***50.2.2 Core Framework of EBE***

The core framework establishment of EBE is based on the four basic requirements of human factors and ergonomics, which mainly includes six levels of content. Level-1 meaning is derived from the actual condition of human factors and the efficiency of ergonomics scientific data (HFES raw data); Level-2 connotation is the discipline level because of the science and efficiency of data retrieval based on content (ontology-based HFES data retrieval); Level-3 connotation is multi-perspective of the conceptual structure and systematic (divergent exploration); Level-4 connotation is the metadata based on specific scenarios (context-based



convergence); Level-5 connotation is the integration of human factors and ergonomics scientific system (HFES concept structure and convergence); and Level-6 connotation is used for identifying and resolving ergonomic issues decision (HFE problem setting and solution).

From Level 1 to Level 6, they are closely related. The lower the foundation is, the higher the lower sublimation is. Finally, discard the dross and select the essential guarantee efficiency, centralized meta-evidence-based ergonomics system.

The main improvement of evidence-based ergonomics system will be affected by five factors. First is technical level, involving the tools, equipment, facilities, and so on. Second is the degree of automation, such as mechanical, computer, and artificial intelligence. Third is the characteristics of the system and relates to dimensions, attributes, variability, and so on. Fourth is human factors, including physiological changes and behavioral changes. Fifth is the relationship between technology and organization, involving diversity organization strategy and organization multiplicities.

## **50.3 Application of EBE in Manned Spaceflight**

### ***50.3.1 SHFE Project Plan (JSC 29022 Rev A)***

Space human factors engineering (SHFE) Project Plan (JSC 29022 Rev A) was published by Habitability and Human Factors, Habitability and Environmental Factors Office of Space and Life Sciences directorate in Johnson Space Center of NASA in November 2001. This document supersedes the Space Human Factors Program Plan (December 1995) [3]. SHFE project implementation plans, which are produced annually, complement this project plan by specifying details of how objectives will be accomplished each year. NASA's SHFE project focuses on reducing human error and the potential disasters that can result. The purpose of the SHFE project is to create and maintain a safe and productive environment for humans in space. There are two major activity paths within the SHFE project: allowing investigators to submit proposals annually for basic human factors research, facilitating mid-level technology advancements, and addressing needed critical research. These activity paths are the available mechanisms for accomplishing SHFE project goals, and there are three ways that include supporting SHFE NASA research announcements (NRAs), managing SHFE technology development projects, and enhancing collaboration with National space biomedical research institute (NSBRI). JSC 29022 RevA and SHFE Project Implementation Plan FY2002-FY2003 (JSC29718) [4] published by JSC of NASA in March 2002 are regarded as the framework documents for forming SHFE database [5].

### 50.3.2 *Space Human Factors Engineering Gap Analysis Project Final Report (NASA/TP-2007-213739)*

Space Human Factors Engineering Gap Analysis Project Final Report (NASA/TP-2007-213739) written by Cynthia Hudy and Barbara Woolford was published in March 2007 [6]. The gap analysis included literature reviews, database searches, interviews with NASA personnel, and, then, a survey of NASA program and project managers as stakeholders. The project was divided into four parts: two phases for data gathering and two for compiling and prioritizing results. Each phase along with the deliverables accomplished during that phase is detailed in Table 50.1.

NASA/TP-2007-213739 finally told gap results a total of 33 items. Among them, the top three items having high degree of concern are display information content, display sizes, and displays and controls ergonomics. Another 30 items gap arrangement results in moderate stakes with 24 items, and there are six items with low stakes.

On the basis of the results of the analysis, in the conclusion section of the report, the advice is given priority to implement the task and its relationship with NASA’s human research project (NASA/TP-2007-213739) to determine the risk (see Table 50.2), namely: list the project sequence priority to make up the shortfall.

### 50.3.3 *Human Health and Performance Risks of Space Exploration Missions (NASA/SP-2009-3405)*

NASA/SP-2009-3405 Human health and performance risks of space exploration missions edited by Jancy C. Mcphee and Jhon B. Charles was published in 2009 [7], which was the first evidence book reviewed by the NASA human research

**Table 50.1** GAP phases and deliverables

Phases	Deliverables
Human factors background review	Space program literature review
	Human factors document review
	Human factors personnel interviews
Field user review	Field user interviews
Gap evaluation	Consolidation/duplication elimination
	Decision analysis factor rating
	Stakeholder ranking
Final prioritized gap results	Prioritized evaluation based on:
	1. Early CEV need in the areas of design and operation
	2. Interview significance
	3. Stakeholder ranking
	4. ESAS recommendations

**Table 50.2** Tasks and their relation to human research program identified risks

Task	Risk		
	Cognitive mismatch	Physical mismatch	Multi-agent tasking
Information presentation	×	×	
Anthropometric verification tools		×	
Behavioral health and performance cognition	×		
Acoustic requirements and models		×	
Design and evaluation tools	×	×	
Crew scheduling tools	×	×	×
Training	×	×	×
Function allocation tools and tech			×

program (HRP) and based on events during spaceflight and practice of manned spaceflight in the world. The book is divided into 15 chapters, including SHFE a total of eight chapters, accounting for more than 50 % that of Chap. 1 Risk of behavioral and psychiatric conditions, appendix named as incidence of physical and behavioral medical was showed in the end; Chap. 2 Risk of performance errors due to poor team cohesion and performance, inadequate selection/team composition, inadequate training, and poor psychosocial adaptation; Chap. 3 Risk of performance errors due to sleep loss, circadian desynchronization, fatigue, and work overload, two appendixes are affixed: international space station(ISS) lighting and mathematical models of human circadian rhythms and performance; Chap. 9 Risk of error due to inadequate information; Chap. 10 Risk of reduced safety and efficiency due to inadequately designed vehicle, environment, tools, or equipment; Chap. 11 Risk of error due to poor task design; Chap. 14 Risk of compromised EVA performance and crew health due to inadequate EVA suit systems, appendix named as gravity compensation and performance scale was showed in the end; Chap. 15 Risk of operational impact of prolonged daily required exercise.

**50.3.4 SHFE Standing Review Panel (2011)**

2011 SHFE standing review panel (SRP) Evidence Review Final Report was published on 12 October 2011 [8]. The report is based on SHFE practice since 2001, puts forward two principles for the evaluation of SHFE evidence report.

The first principle for the evaluation of every evidence report on SHFE should cover the ten aspects of content:

- A. Does the SHFE Evidence Report provide sufficient evidence that the risk is relevant to long-term space missions?

- B. Is the risk properly stated in the HRP Program Requirements Document (PRD Rev.E)?
- C. Is the text of the short description of the risk provided in the HRP PRD REV. E clear?
- D. Does the evidence make the case for the knowledge gaps presented?
- E. Are there any additional gaps in knowledge that should be considered for this specific risk?
- F. Does the SHFE Evidence Report address relevant interactions between this risk and others in the HRP PRD REV. E/IRP Rev. C (Integrated Research Plan, Rev. C)?
- G. Is the expertise of the author(s) sufficient for the given risk?
- H. Is there information from other disciplines that need to be included in the SHFE Evidence Report?
- I. Is the breadth of the cited literature sufficient?
- J. What is the overall quality and readability?

The second evaluation principle is to provide comments on any important issues that are not covered in principle 1.

According to the evaluation principles, five new SHFE risks were evaluated by SHFE SRP. The five kinds of SHFE new risk include the following: 1. The spacecraft cabin and cabin design are not harmonious (the risk of an incompatible vehicle/**habitat** design, HAB); 2. people with computer interface design is not appropriate (the risk of inadequate **human-computer interaction**, HCI); 3. people with automation or robot integration design is not appropriate (the risk of inadequate design of the **human and automation/robotic integration**, HARI); 4. lack of **training** error (the risk of performance errors due to training deficiencies, TRAIN); and 5. critical poor design or inappropriate spaceflight mission (the risk of poor critical **task** design, TASK).

2011 SHFE SRP (Standing Review Panel) Evidence Review Final Report list shows the interactions between the five kinds of SHFE new risks and other HRP (human research program) risks (see Table 50.3).

### ***50.3.5 Evidence Report: Risk of Inadequate Critical Task Design (2013)***

Evidence report: Risk of inadequate critical task design (TASK evidence report, 2013) edited by Anikó Sándor, Susan V. Schuh, and Brian F. Gore from HRP and SHFH was published in March 2013 [9]. Risk of inadequate critical task design, for short TASK, is one of the five new risks identified by SHFE SRP of NASA [7]. TASK evidence report (2013) is divided into 12 parts. Part one to part nine are belong to the body parts, part 10 is references, part 11 is head of the team list, and part 12 is acronyms list of the report.

**Table 50.3** Interactions between SHFE risks and other HRP risks

	HAB	HARI	HCI	TRAIN	TASK
BHP-bmed	×	×	×	×	×
BHP-sleep	×	×	×	×	×
BHP-team	×	×	×	×	
HHC-cardio	×				
HHC-EVA	×	×	×	×	×
HHC-nutrition	×				
HHC-occupant protection	×				
HHC-sensorimotor	×	×	×	×	
HHC-VIIP	×				×
SHFH-dust	×	×			×
Space radiation-CNS				×	

TASK evidence report (2013) in the conclusion part points out that the TASK risk exists between the crew and spaceflight mission, and robots or automation, and ground controllers, etc. Workload is crew and system has to face an important problem. The core of the key design of the task is the distribution of the workload and integration.

TASK, therefore, the risk of confirmation and solution will be long-term space exploration mission of one of the most important ergonomics guarantee.

## References

1. Silveira DM (2012) Evidence-based ergonomics. *Work* 41:487–495
2. Jensen OC (2009) Ergonomics and epidemiology in evidence based health prevention. In: Bram N Brinkerhoff. *Ergonomics*. Nova Science Publishers Inc, New York
3. JSC 29022 Rev A (2001) Space human factors engineering project plan
4. JSC 29718 (2002) Space human factors engineering project implementation plan
5. Woolford B, Rathjen T, Whitmore M et al (2003) Space human factors advanced development projects[EB/OL]
6. NASA/TP-2007-213739 (2007) Space human factors engineering gap analysis project final report
7. NASA/SP-2009-3405 (2009) Human health and performance risks of space exploration missions
8. SHFE SRP (2011) Space human Factors engineering standing review panel evidence review final report[EB/OL]
9. Sándor A, Schuh SV, Gore BF (2013) Evidence report: risk of inadequate critical task design[EB/OL]

# Chapter 51

## The Improvement on Space Human Factor Engineering of NASA

Jing Qiang and Yuanyuan Zhang

**Abstract** Space human factor engineering, considered as one of the most important ingredients of NASA human research program, provides the pivotal technical assistant for NASA designing a new generation space station system. In order to provide reference for the development of our nation's manned spaceflight, the paper states the latest progress of space human factor engineering project of NASA, including the stroboscopic countermeasure, the effects of high suit pressures on gloved performance, the unobtrusive measurement of workload, the usability evaluation, the human-machine integration, and the improvement of lighting.

**Keywords** Space human factor engineering · Human factor · Manned spaceflight

### 51.1 Introduction

As one of the important components of NASA human research program, space human factor engineering project provides key technical support for NASA's new generation of space station system.

To guarantee the long-term and high-efficient operation of crew in the space, space human factor engineering scientists and engineers have carried out a series of researches, including tests in laboratory, in simulation environment and ultimately in actual spaceflight. In recent years, substantial data have been collected to prove the assistance of working environment, operating tools, and system operating interface of crew to tasks [4]. In all fields, the work of space human factor engineering project team was more closely related to experts' design and space operation, which has solved the integration of humans and system suitably and timely.

---

J. Qiang (✉) · Y. Zhang  
Astronaut Center of China, Beijing 100094, China  
e-mail: qiang\_jing@163.com

This paper mainly summarizes the updated research development of the project in recent two years for China's manned spaceflight researchers.

## **51.2 Main Research Progresses**

### ***51.2.1 Utilizing the Stroboscopic Countermeasure to Improve the Human Vision Under Vibration***

The vibration of a spacecraft causes the human's head wagging, leads to dimness of vision, affects the displayed information read by crew, and even damages astronauts' supervising capacity of and controlling capacity to a spacecraft. A series of early experiments and centrifugal researches demonstrated that the whole body's vibration when launching would cause the lowering of the human visual function.

On the basis of these researches, space human factor engineering researched and verified the stroboscopic countermeasure, so as to "freeze" image moving and eliminate the vagueness of statistic objects, while observing vibrantly. The corresponding visual interference is provided by quickly turning on the computer display panel, switching "on" and synchronically monitoring the vibrating mode of crew seats.

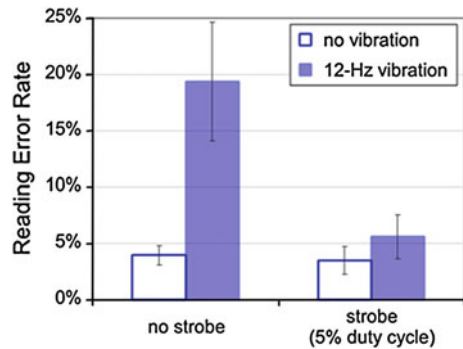
In the testing research of displaying readability, 11 subjects were tested under chest-to-spine vibration at the maximum vibration rate to simulate the space exploration, and then, the results were contrasted with zero vibration. By construction, the effect of stroboscopic countermeasure was verified. During a strobe duty cycle, the display was being switched "on" for 5 % of the time and "off" for 95 % of the time. Stroboscopic countermeasure can reduce the reading errors. The data from the strobed and non-strobed conditions did not indicate the difference in the statistics.

Apart from applying in manned spaceflight, this technology can also be used in other high-rate vibration environment, for example, on flight, ground, and marine delivery vehicles. NASA has applied patent for this invention (Fig. 51.1).

### ***51.2.2 Research on the Effect of High Suit Pressures on Gloved Performance***

The future spaceflight task may deal with some emergencies. It requires the suit pressure be higher than the normal level. Cooperating with extravehicular activity (EVA) research team of Johnson Space Center, the researchers of human factor engineering project develops a research on pressure gloves project, so as to research the strength, moving ability of hand, and the ability to perform small

**Fig. 51.1** Reading error rates for subjects exposed to stroboscopic countermeasure



control in pressure spacesuit. In this feasibility research, the glove performance was measured under a scope of pressure [1].

Four subjects performed operation control, including a capacitor switch, a pressure switch, a trackball operation, push buttons, power-on key, and a rotating knob. All the control operating types represent the space human factor designing elements of future space delivery vehicles. The capacitor switch, pressure switch, and trackball operation were tested the fundamental cursor control technology by using software.

The results showed that in terms of mobility, the increased pressure influenced the mobility of thumb more than that of index finger and middle finger. Moreover, the gripping force of hand while wearing gloves decreases by about 25 %. With the increase of pressure, it reduces by only 15 %.

It is the balloon effect of gloves under high pressures, which would affect the gripping capability of participants. Using cursor control technology, the response time of capacitors' switching is lengthened with the increase of suit pressure, whereas the response time of operating pressure switch is not affected. The influence of response time of the trackball operation was the most when increasing the pressure. Most of the operation errors resulted from the operation of tracking ball.

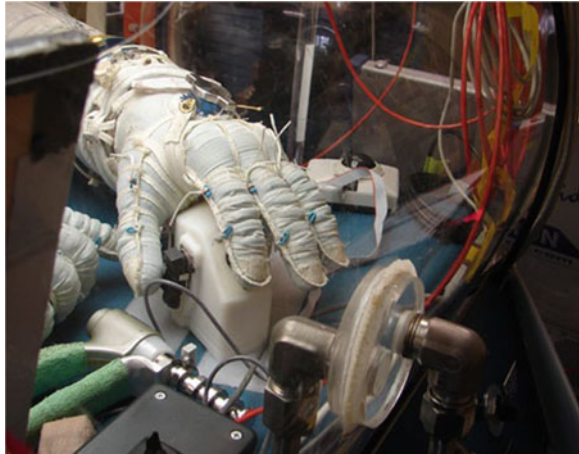
It is well-known that it is the first time to conduct the exquisite operation under such high pressure. It is planned to expand the research project to evaluate performance with different hands and glove sizes. Meanwhile, while designing performance and glove finger sizes, they would pay more attention to the flexibility and tolerance (Fig. 51.2).

### ***51.2.3 Common Test on the Workload for Long-Term Flight Mission***

Space human factor engineering conducted a common test and management requirement research for the workload. When researchers designed the operating interfaces, operating procedures, and schedules, the allowed workload was



**Fig. 51.2** Subjects assessed the operability of various controls inside a pressurized glove box



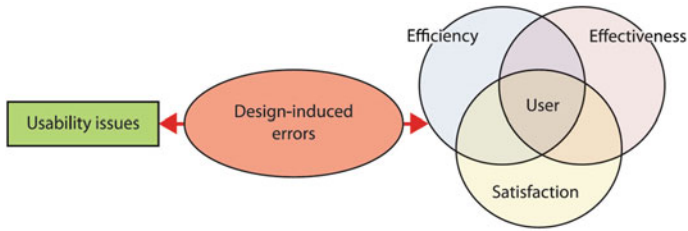
maintained during the whole mission. The analysis of three crews' reports was beneficial to the required considering variables [1].

This research activity includes the overview of system operation and system engineering processing procedures. The research of the two conceptual models was related to long-term flight task operation so that these models are expected to be used for providing suggestions for the future research. The new technology measured the common workload in all designing phases, proving feedback of measured workload to astronauts. Astronauts use the information to execute all kinds of tasks in order to guarantee the success and safety of flight missions.

#### ***51.2.4 Taking Error Ratio as the Measurement Standard While Researching Usability Requirement***

Many standards can be chosen to make the operational evaluation of "usability," for example, effectiveness, efficiency, and satisfaction degree. The three factors are very important, and they are the key factors of human-centered design. The evaluation on "usability" of system is beneficial to maintain crew health and safety. Moreover, the improvement of usability can reduce error operations, training time, and total life cycle cost, which is very necessary to guarantee crew safety and task success.

When proposing the requirement of usability, the space human factor engineering researchers focused on error ratio as the evaluating standard of options [1]. Measurement is objective and easily understandable and is related to all factors of usability. All the spaceflight tasks must be implemented by formally formulated procedures. Thus, the usability issues were determined by calculating error ratio of each operating procedure and each participant, rather than calculating the total error ratio. And the priority is focused on the error operation caused by the design.



**Fig. 51.3** The relationship among errors, usability issues, and the three main factors of usability

While conducting the usability testing, the key points shall focus on detecting the steps related to error operation. The determination of these steps indicates that the usability issues exist. It is related to the design of hardware, software, and operating instructions. It is the same important as detecting many error operations caused by participants. The requirement of usability considers these factors. It shall be taken as the standards while testing and simulating. The result guarantees the minimization of error operations caused by design for each operating procedure and each participant.

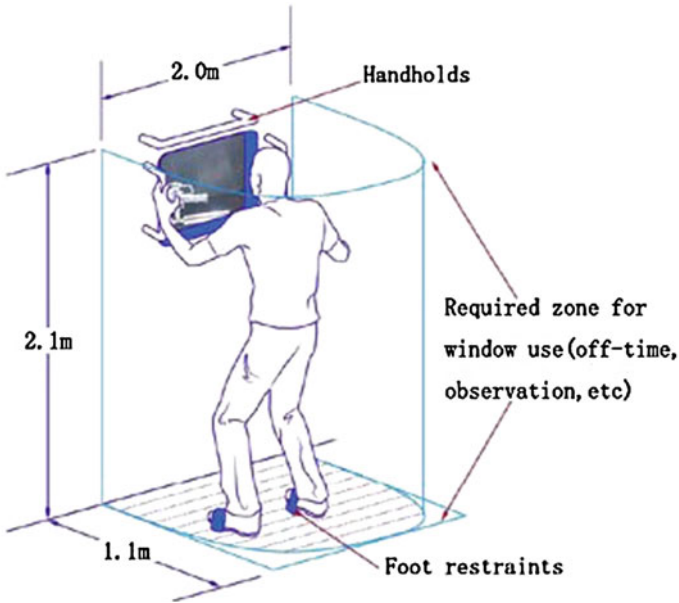
In a NASA document, it is an important achievement to propose usability requirement because it is the first step to consider the full usability in the designing period. NASA is pioneering in reforming the practice of usability by using the objective methods to verify the usability and proposing a reasonable usability requirement (Fig. 51.3).

### ***51.2.5 The First Amendment Completing the Human Integration Design Handbook***

NASA establishes the formal human factor standards for spacecraft and living places. These standards are listed into the two volumes of NASA-STD-3001 Space Flight Human System Standard. The first volume deals with crew health standard, and the second volume involves in the habitability and environmental standard.

Human-integrated designing handbook (HIDH) is a companion file to the second volume, including the human–system integration data from former manned spaceflight projects. Its purpose is to guide the design of vehicle and living place in the second volume. For example, the guidance covers the required room of window and suitable handrail at the living places [5].

In 2012, NASA started the revision of HIDH once of 2 years. The purpose of revision aimed to increase the acquired new findings and operating information since the HIDH was formulated in 2010, providing updated materials and comments. Meanwhile, a team of technical experts joined to guarantee the correctness of the content and the top quality [2].



**Fig. 51.4** The HIDH provides design and background information from research and operational lessons learned

The major modification included the increase of a chapter on vibration involving the human health and performance, update of physical and cognitive load information, acoustic noise control plan, the protection design of inhabitants, protecting measures of exercise and the design of lighting and habitable capacity, and crew interface design.

The handbook is revised completely in 2013 and can be inquired from the following Web site [3].

<http://www.nasa.gov/centers/johnson/slsd/about/divisions/hefd/standards/index.html> (Fig. 51.4).

### ***51.2.6 Using Models to Evaluate the Help of Robotics on Crew***

The human-machine integration designing and analysis system function allocation support tool (MIDAS-FAST) researched by space human factor engineering project is one of the recognized tools by NASA [2]. This tool can help answer the following issues. When conducting future space missions, how does the robotic system help operators perform a task?

This tool allows the researchers at NASA to compare different robotic system according to the predicted influence on operators and system performance. After acquiring the data of proposed robot system, MIDAS-FAST can determine how it realizes the automation and its reliability. After that, this tool can evaluate the performance of operators under special conditions, for example, focus of visual attention, disorientation, the performance of operators due to poor view, and control–response worsening. Then, it can give feedback on the predicted working indicators of an operator, such as time, error rate, workload, and situation awareness. The analysts can compare the robotic system by utilizing the results and the prediction performance.

Presently, the model is used for evaluating and perfecting the data collected in the human-in-the-loop research period, including time, errors, eye movements, and watching time to complete tasks. By using MIDAS-FAST model, the experimental data are compared to determine whether the model correctly predict the performance of operators, which is beneficial for NASA researchers and designers to evaluate the effect of future robotics in the manned spacecraft.

### ***51.2.7 Adjusting the Space Station Lighting to Improve Crew Performance***

Most researches indicate that bright and suitable light can provide a safe, reversible, and non-drug countermeasure to adjust the circadian rhythms of human body and increase the alertness and improve performance. On the contrary, due to the lack of proper lighting, the symptom will occur, such as insomnia and lowering of health status and performance.

Since 2011, the representatives from human body research plan and space human factor engineering project recommend replacing solid-state lighting assemblies (SSLA) on the international space station. New fixed SSLA can be adjusted in their light intensity and wavelength according to the requirement. This lighting system can make crew control and use the lighting. For example, when crews adjust their circadian rhyme to adapt to another time zone or conduct operations at night, turn on the blue-white light.

It is suggested to replace the lighting assemblies at the No. 2 node cabin at the international space station, including replacing the lighting assemblies of single crew sleeping quarters, secondarily replacing the lighting assemblies countering abrasion, meanwhile, suggesting using new fixed SSLA lighting to increase the illumination for conducting operation. In order to reduce the time that crew take in adjusting light and evaluate the lighting scheme and the effectiveness of countermeasures, the implementing plan is ratified by the program board of the international space station.

Presently, both the crew health and performance project team and space human factor engineering project team are soliciting for the research guidance and rationality for using light as a countermeasure, so as to meet the minimization for requirement of human body health.

### **51.3 Enlightens and Suggestions**

1. The 50-year process of developing manned spaceflight shows that the success of manned spaceflight program depends on the high efficiency, reliability, and safe interacting ability of crew, vehicles, and environment. The development of manned human factor project is the important guarantee for the manned spaceflight to develop sustainably and healthily.
2. Long-term manned flight is the important direction to develop China's manned spaceflight technology. Timely developing the research on habitability can guarantee the habitability issue of long-term manned spacecraft being sufficiently solved and the project goal being achieved. The research shows that the inhabitability within the cabin plays a very important role in improving performance and extending stationed time. Thus, if the condition allows, the research and formulation of human–system integration system should be started, with a view to ensuring crew health both in physiology and psychology, confidence and high performance in conducting flight task during the long-term flight.
3. Although the modern manned spacecraft has mostly been under automation, human–machines system structure to achieve the task goal is an irresistible trend. Therefore, the creation of balanced optimization structure must be stressed, so as to unite crew, manned cabin system, flying control center, and ground users as integration. If optimization is insufficient, the astronauts will overload their work, and then, the performance would lower and make errors when conducting task.

### **51.4 Conclusions**

China's future manned spaceflight missions in the future include the establishment and running of space station, the future manned moon-base exploration, and deep space exploration. It presents higher and harsher challenges to the development ergonomics and brings forth more opportunities. Having based on it, we need to orientate the actual conditions of project research and need of spaceflight tasks, learn the experience obtained from foreign research on space human factors, and improve the research methods and technical measures on orbit working ability of China's crew at higher and deeper degree, so as to make the research results of space human factors to serve better the China's manned spaceflight.

## References

1. Human Research Program Annual Report (2011) NASA
2. Human Research Program Annual Report (2012) NASA
3. Human Research Program Annual Report (2013) NASA
4. <http://www.nasa.gov/exploration/humanresearch/index.html>
5. NASA-SP-2010-3407 Human Integration Design Handbook (2010)

# Chapter 52

## Man–Machine–Environment Systems Engineering Research Based Mental Workload Measurement Model of Using Software

Baiqiao Huang and Yuanhui Qin

**Abstract** The traditional methods of mental workload measurement include the main task metrics, subtask metrics, physiological measurements, and subjective measurements. First, these evaluations are subjective, not considering the objective content of the task itself; second, these evaluations focus on the output of the task and do not consider mental processes during task execution, and therefore, the evaluation results are subjective and not overall. This paper takes the measurement of mental workload of using software as the research object, from the man–machine–environment systems engineering (MMESE) perspective, according to the information input of the task itself, as well as the information processing and decision-making process to build mental workload measurement model of software operation. And two evaluation indexes are given from the objective and subjective factors separately. Finally, this model is applied to evaluate the mental workload of shipboard command software’s core function, and some design suggestions have been given for reducing the mental workload.

**Keywords** MMESE · Mental workload · Decision-making modeling

### 52.1 Introduction

The workload is divided into two aspects as physiological workload and psychological workload, and the psychological workload is usually called the mental workload. With the development of technology, hardware function is gradually replaced by software; similarly, the workload is gradually changing from physiological workload into mental workload. Nowadays, the study of the mental

---

B. Huang (✉) · Y. Qin  
System Engineering Research Institute of China State Shipbuilding Corporation,  
Beijing 100094, China  
e-mail: bq\_huang@126.com

workload has been paid more and more attention since exorbitant mental workload of the project will not only affect the efficiency, but also affect the accuracy of task completion and even cause serious security incidents.

The earliest study of mental workload was conducted by American psychologist Miller [1]. Despite interest in the topic for so many years, there is no clearly defined, universally accepted definition of mental workload. The original definition of mental workload is referred as the human psychological activity workload in unit time, and it mainly results from monitoring, decision-making, and anticipation, without obvious physical work. In 1977, the participants in a special academic session about “theory and measurement of mental load” which was conducted by the North Atlantic Treaty Organization concluded that the mental workload was a multidimensional concept, and it related to the working requirements, time pressures, and the ability of the operator effort, and many other factors behavior, so it is difficult to define uniquely. Since then, scholars give various definitions from different point of view. Young and Stanton [2] stated that “the mental workload of a task represents the level of attention resources required to meet both objective and subjective performance criteria, which may be mediated by task demands, external support, and past experience.” Wichens and Hollands [3] and Wichens et al. [4] defined the mental workload in the view of resource capacity, and it is defined as the ratio between the work-occupied resources and available resources. Chinese scholar Jianqiao and Wenbi [5] thinks that mental workload is an indicator for the situation of the human information processing system being used. Researchers have come to realize that mental workload is thought to be multidimensional and multifaceted, and should not be too theoretical understanding to pursue consistent definition, but should pay more attention to the operational definition [6].

With the development of software technology, software has become an important part of weaponry. In particular, for some control and decision support system, software is the dominant. The operation process of this kind of system mainly consumed mental resources, and the physical resource needed is very little, and the configuration of the mental workload in one task will seriously affect the efficiency and performance of the operator. So we take the measurement of mental workload for the interaction of software operation as the object of our research in this paper. The traditional method of mental workload evaluation mainly includes primary task measures, secondary task measures, physiological measures, and subjective rating scale measures [7]. According to the methods above, we can conclude that first the measurement is conducted through the output or effect of task execution and second the measurement is conducted through comprehensive subjective evaluation. These measures are all subjective evaluation and do not consider the objective content of the task itself. In consequence, the recommendations for design improvement cannot be made.

From the man-machine-environment system engineering perspective, a comprehensive and systematical analysis for factors which affect the human mental workload is stated in this paper. After analyzing the man-machine-environment system model and decision-making process model of using software, the mental



workload measurement model of using software is constructed, and two indexes considered, each from objective and subjective aspects, are set up. The mental workload measurement model proposed here has considered the objective content of the task itself, and the conclusion can be used to estimate the design scheme during design phase, and it is focused on the decision-making process of software use. As a result, the shortcomings of traditional evaluation methods are made up properly.

## **52.2 MMESE-Based Software Interaction Process Modeling**

### ***52.2.1 MMESE Model of Software Interaction***

The man–machine–environment system engineering (MMESE) is a science which focuses on the relationship between man, machine, and the environment and deeply studies the optimal combination of man, machine, and environment by using the system science theory and system engineering approach [8]. Software system is a typical man–machine–environment system; therefore, the MMESE thought is naturally used to analyze the interaction process and the mental workload measurement when using software. As a result, the factors which effect the mental workload measurement should be explored systematically, and a comprehensive measurement model has been constructed. This paper takes a shipboard command software as an example, and the man–machine–environment system of software use is as shown in Fig. 52.1. The operator receives the target information and the device status from the software interface, makes decision, and gives command orders to the target as an output. The operator is also influenced by the microclimate environment factors in this process.

According to the analysis of the man–machine–environment system of software use, we can make a conclusion that main factors influencing the mental workload of software use include three aspects, namely the human factors, the machine factors, or task factors, and the environment factors. For details on the three factors, see Sect. 52.3.1.

### ***52.2.2 Decision-Making Model of Software Use***

The essence of software operation process is the decision-making process after the operator receives information. Rasmussen [9] has distinguished the human behavior performance into three categories: skill-based behavior, rule-based behavior, and knowledge-based behavior, so does the decision-making process. The knowledge-based decision-making appears when the operator is in lack of

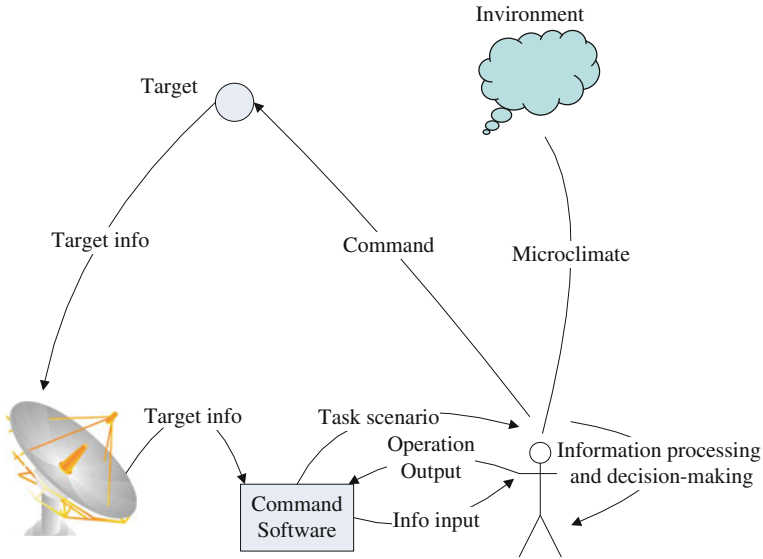


Fig. 52.1 Man-machine-environment system of software use

experience; after some accumulation of experience, the decision-making level upgrades to the rule-based category, and when the operator becomes proficient in it, he can perform a skill-based decision and finish the task rapidly. The assessment of decision-making process during software use can refer to Rasmussen's thinking, and also be organized into three categories. The decision-making model of software use is as shown in Fig. 52.2. As we all know, the operation of software usually has a specific instruction, called user manual, and few new situation will appear after the operators become familiar with the tasks. Therefore, in addition to some simple logic operations become skill-based decision-making, most software tasks belong to rule-based category, namely receive and recognize the input information provided by the software interface, compare them with the rules stored in the brain, and make decisions to take action. While the knowledge-based decision-making appears when the software has fallen into abnormal situations, the operators should carry on the analysis of the software exception information based on his existing knowledge, and then, the decision-making process changes to a rule-based one.

The model showed in Fig. 52.2 not only reveals the generation process of mental workload when using software, but also reveals the factors affecting the mental workload of the task itself. There are three main factors: First is the amount of input information, the more information the input has, the more efforts of the mental workload you should cost, which need to be spent on receiving and recognition. The second is the category of decision-making; skill-based decision-making costs the least mental workload, then the rule-based one, and the most efforts result from the knowledge-based decision-making. The last is the rules for

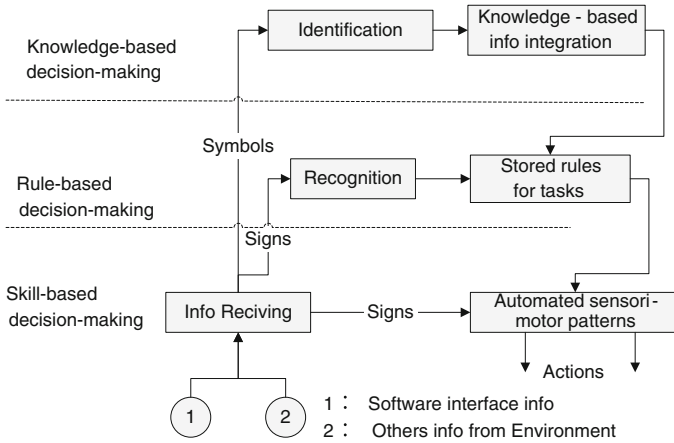


Fig. 52.2 Decision-making model of software use

decision, namely the complexity of the decision logics, the more complex the decision logics are, the more mental workload the operator should spend. The three factors mentioned above can be recognized as the objective factors, since these factors are independent of different operator.

## 52.3 Mental Workload Measurement of Software Use

### 52.3.1 Measurement Model of Mental Workload

In this paper, we conclude that there are three main factors which affect the mental workload of software use, namely the human factor, the task factor, and the environment factor. The human factor is a subjective one, and it is related to the operating personnel, including personal mental level, skills and experience, subjective will, as well as the support of physiological conditions. Task factor is an objective factor, which means it is independent from personnel and is only associated with the software design, including the amount of information input, the type of decision-making, the complexity of decision-making logic, allocated task time, continuous task time, and task scenarios. For military software, task scenarios are generally divided into two types: training scenarios and combat scenarios. Environment factor is the microenvironment in which the operator is placed in.

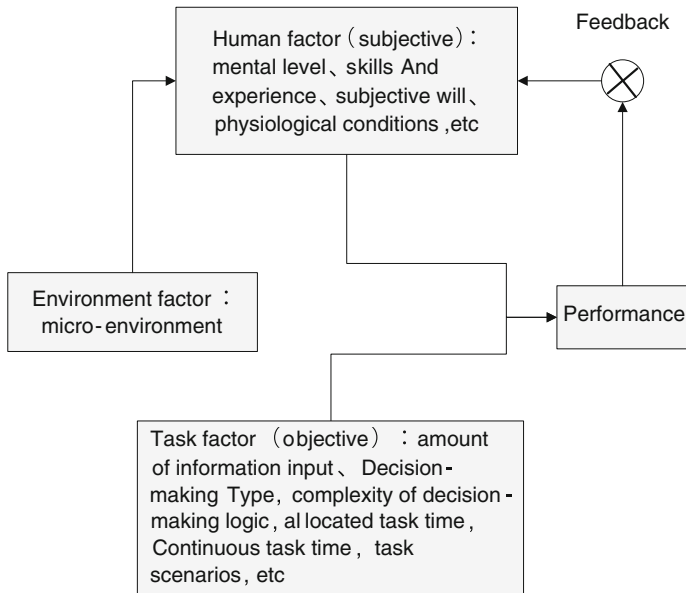
It found that there is another important factor which affects the mental workload, when we analyze the software use process systematically, that is, the performance of software task. According to the mental workload model developed by D. W. Jahns [6], the mental workload is related to three main aspects such as the

input workload, operator's effort, and the performance, and the performance factor will affect the effort factor. In fact, good performance will boost operator's confidence, while bad performance will enhance the operator's mental pressure and result in intense negative emotions. In conclusion, a comprehensive mental workload measurement model is constructed and shown as in Fig. 52.3.

### ***52.3.2 Measurement Indexes of Mental Workload***

There are two principal reasons for measuring workload: One is reducing the mental workload under the premise of meeting mission requirements, and the other is reasonable allocation of mental workload during the software task, for improving the operating performance. However, mental workload assessment is a very complex problem. It involves mental workload generation mechanism, the problem of mental workload effects of each factor inherent laws, as well as some unknown aspects of psychology. It involves mental workload generation mechanism, the problem of mental workload effects of each factor inherent laws, as well as some unknown aspects of psychology. So, we cannot give a complete and quantization measurement index system. In this paper, some localized indexes from different point of view have been proposed and are used as a reference for the allocating the task mental workload and the improvement of software design. Two indexes are set up here, one is the mental workload prediction measurement index which based on the objective factors, and the other is the task time occupation rate index which based on the subjective factors.

1. **Mental workload prediction measurement index:** In the process of software design, we not only need to compare the pros and cons between different schemes, but also need to assess whether the selected design meets the mission time performance. This comparison should be independent from the individual factors of the operator and only related to software task itself, so we need to consider the objective factors which affect the mental workload. If we put the operator as a stable output machine, then the mental workload can be reflected by the operation reaction time. From Fig. 52.2, we can conclude that the workloads mainly result from information receiving and decision-making; we can obtain the average reaction time of different information input and the average reaction time of different type of decision-making and decision logic through experiments and thus predict the average reaction time of the software tasks. And this index can be used for the comparison of different design schemes. The experiment of the average reaction time will be carried out in the course of the study's follow-up.
2. **Task time occupation rate index:** In the software testing phase, we need to assess the operator's ability adapt to the existing design and whether the operator can comfortably complete the task within the stipulated task time. Here comes the mental level of the operator, skills and experience, and time



**Fig. 52.3** Mental workload measurement model of software use

performance requirements of the task. We set up a comprehensive index: The ratio of which the task real completion time share the task stipulated time. This index is also known as “time pressure” index. Time pressure index represents the degree of difficulty to complete the task within personal capabilities. We can use it as a basis to select the appropriate operator.

## 52.4 Examples of Application

The model established in this paper has been used to assess the mental workload of a shipboard command software as an example. One of the core functions of the software is that according to the target information provided by the software interface, ship’s own speed and heading information, and the sea state information, the commander makes a comprehensive decision and gives the command for the target instruction. At present, this software belongs to the design stage; in order to reduce the mental workload of software task, we put forward the suggestions for the improvement in two ways: one is reducing the number of information input, and the other is optimizing the decision logic to reduce the complexity of decision-making. The effectiveness of these improvement suggestions needs to be verified in the follow-up experiments.

## 52.5 Conclusions and Prospect

An evaluation model of mental workload for software use based on man-machine-environment system engineering is proposed in this paper. In this model, three main aspects which affect the mental workload from the human factors, the task factors, and environment factors are analyzed systematically, and the man-machine-environment system model and decision-making model of software use are established, and two indexes which reflect two aspects of objective and subjective performance are set up. In the analysis of mental workload for a shipboard command software, this evaluation model has been applied to analyze the core functions of the software, and some suggestions with the purpose of reducing the mental workload have been given out.

Certainly, the model established in this paper is only a framework for the evaluation of mental workload; there is a lot of content needing further research in this framework, such as the influence mechanism of various factors on the mental workload, the average reaction time in the decision-making model, and these should be the contents of this follow-up study. In a word, the mental workload measurement of software use is a big topic, and this paper just plans a general frame and is the first step for the follow-up deep study.

## References

1. Li JB, Xu BH (2009) Synthetic assessment of cognitive load in human-machine interaction process. *J Acta Psychol Sin* 41(1):35–43
2. Young MS, Stanton NA (2001) Mental workload: theory, measurement, and application. In: Karwowski W (ed) *International encyclopedia of ergonomics and human factors*. Taylor&Fran, London, pp 507–509
3. Wichens CD, Hollands J (2004) *Engineering psychology and human performance*. M East China Normal University Press, pp 558–573
4. Wichens CD, Lee J, Liu Y et al (2007) *Introduction to human factors engineering*. M. East China Normal University Press, pp 327–330
5. Jianqiao L, Wenbi W (1997) A study of the effect of working time on mental workload. *J. Chin J Ergon* 3(4):16–21
6. Li S, Su L, Song S (2010) Review of studies on psychological workload of workers in man-machine system. *J Beijing Jiaotong Univ (Soc Sci Ed)* 9(3):54–58
7. Kai C, Lin-yan S, Tai-wen F et al (2008) New developments in measurement methodologies of mental workload. *J Ind Eng J* 11(5):1–5
8. Long Z (1993) *Man-machine-environment system engineering theory and its significance in productivity development*. Progress in man-machine-environment system engineering research, vol 01. Beijing Science and Technology Press, Beijing, pp 2–13
9. Rasmussen J (1983) Skills, rules, and knowledge; signals, signs, and symbols, and other distinctions in human performance models. *J IEEE Trans Syst Man Cybern* 13(3):257–266

### **Author Biography**

**Baiqiao Huang** Baiqiao Huang, senior engineer, born in 1980, doctor of engineering, graduated from Beihang University, and his research direction includes system engineering, reliability design and analysis, and software engineering.

Topics: Applications research of MMESE