

## Chapter 2

# A New Ranking Method Approach for Decision Making in Maintenance Management

Fausto Pedro García Márquez, Alberto Pliego, José Lorente and Juan R. Trapero

**Abstract** Decision making process in maintenance management produces a final choice. Fault Tree Analysis (FTA) is proposed as a graphical representation of logical relationships between the elements that comprise the decision making process in maintenance management. A Fault Tree (FT) is compound by different events and logic gates. Complex systems analysis may produce thousands of combinations of events (cut-sets) that can cause the system failure. The determination of these cut-sets can be a large and time-consuming process even on modern computers. Binary Decision Diagrams (BDD) provides a new alternative to the traditional cut-set based approach for FTA that leads to the determination of the function output value through the examination of the input values. BDD is a directed acyclic graph that represents the Boolean functions. The cut sets generated by BDD will depend on the events ordering. The “Level”, “Top-Down-Left-Right”, “AND”, “Depth-First Search” and “Breadth-First Search” methods have been considered for listing the events, and a comparative analysis of them has been done. A new ranking approach is proposed in this paper, where its efficiency has been validated.

**Keywords** Decision making · Maintenance management · Fault Tree Analysis · Binary decision diagrams

## 2.1 Introduction

The study of methods and procedures, by which concerns about multiple conflicting criteria, are taken into account by the International Society on Multiple Criteria Decision Making in order to be formally incorporated into the management planning process. Fault Tree (FT) is used in this paper for supporting decision-making activities in maintenance management.

---

F. Márquez (✉) · A. Pliego · J. Lorente · J. Trapero  
Ingenium Research Group, University of Castilla-La Mancha, Ciudad Real 13071, Spain  
e-mail: FaustoPedro.Garcia@uclm.es

A FT model is a graphical representation of logical relations between events (usually failure/fault events). Complex systems analysis may produce thousands of combinations of events (cut-sets) that can cause the system failure, i.e. the top event occurrence. The determination of these cut-sets can be a large and time-consuming process even on modern computers. The determination of the exact top event probability also requires lengthy calculations if the FT has a great number of cut-sets.

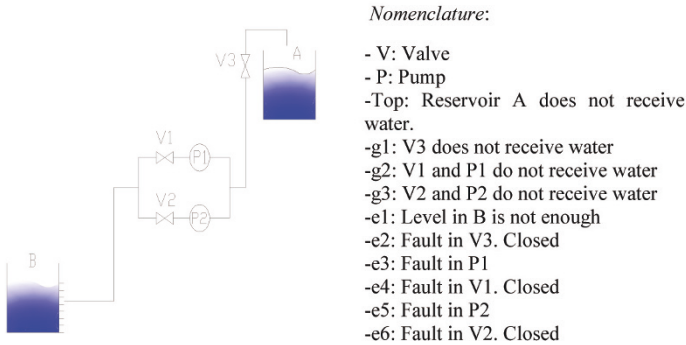
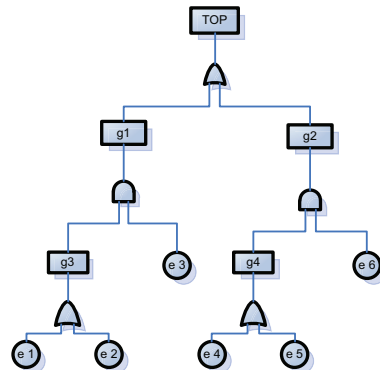

**Fig. 2.1** Pumping station

Approximation techniques have been introduced with a loss of accuracy in order to reduce the computational cost of the FT analysis (FTA). BDD provides a new alternative to the traditional cut-set based approach for FTA. This technique leads to the determination of the function output value through the examination of the input values. Fig. 2.1 shows a simple example in order to describe the FTA and the use of BDD. The problem consists of flowing water from the tank B to the tank A through the pipes that connect both tanks.

The FT associated to the system shown in Fig. 2.1 is showed in Fig. 2.2.

**Fig. 2.2** FT associated to the system shown in Fig. 2.1



## 2.2 Binary Decision Diagram

Binary Decision Diagrams (BDDs), as a data structure that represents the Boolean functions, were introduced by Lee [3], and further popularized by Akers [13], Moret [1], and Bryant [12].

A BDD is a directed acyclic graph  $(V, N)$ , with vertex set  $V$  and index set  $N$ . Vertex set contains two types of vertices. On the one hand, a terminal vertex has as attribute a value:  $\text{value}(v) \in \{0, 1\}$ , where “1” state corresponds to the system failure, or “0” state that corresponds to the system success. All the paths that have 1 state provide the cut-sets of the fault tree. On the other hand, a non terminal vertex  $v$  has as attributes an argument  $\text{index}(v) \in N \setminus \{0, 1, \dots, n\}$ , and two descendants,  $\text{low}(v)$  and  $\text{high}(v) \in V$ , that are connected by a branch. Each vertex has a vertex 0 branch that represents a non occurrence basic event, or 1 branch that represents an occurrence basic event. For any non-terminal vertex  $v$ , if  $\text{low}(v)$  is also non-terminal, then  $\text{index}(v) < \text{index}(\text{low}(v))$ , and if  $\text{high}(v)$  is non-terminal, then  $\text{index}(v) < \text{index}(\text{high}(v))$ .

A BDD has a root vertex  $v$  that leads to denote a function  $f_v$  defined recursively as: Firstly, if  $v$  is a terminal vertex and  $\text{value}(v) = 1$ , then  $f_v = 1$ . In other case, when  $\text{value}(v) = 0$  then  $f_v = 0$ ; Secondly, if  $v$  is a non terminal vertex with  $\text{index}(v) = 1$ , then  $f_v$  will be:

$$f_v(x_1, \dots, x_n) = x_i \text{flow}(v)(x_1, \dots, x_n) + x_i \text{high}(v)(x_1, \dots, x_n).$$

## 2.3 Conversion from FTA to BDD

The following template conversion method is used for obtaining the BDD from the FTA. Then the level of unreliability can be easily determined from the BDD.

Let  $A$  be a vertex set as  $A = A(A_1, \dots, A_n)$ . If  $A_1, \dots, A_m$  are the  $A$  descendant vertices, then:

$$\text{index}(A(A_1, \dots, A_n)) = \min(\text{index}(G_i)), 1 \leq i \leq n.$$

Let  $x_1, \dots, x_m$  be Boolean variables, then the following expressions can be obtained:

- If  $R(x_1, \dots, x_m) = S(x_1, \dots, x_m) \cup T(x_1, \dots, x_m)$ , using “binary OR template”, then BDD of  $R(x_1, \dots, x_m)$  is denoted as:  $R = \text{ite}(S, 1, \text{ite}(T, 1, 0)) = \text{ite}(S, 1, T)$ , where “ite” means If-Then-Else.
- If  $R(x_1, \dots, x_m) = S(x_1, \dots, x_m) \cap T(x_1, \dots, x_m)$ , employing “binary AND template”, then BDD of  $R(x_1, \dots, x_m)$  is obtained as:  $R = \text{ite}(S, 1, \text{ite}(S, 1, 0)) = \text{ite}(S, 1, T)$ .

Let  $G_1, G_2, \dots, G_n$  be a BDD. According to the previous equations it is possible to get the next rules:

- Get-rid-of formula

$$\begin{aligned} \text{ite}(1, G_1, G_2) &= 1 \cdot G_1 + 1 \cdot G_2 = 1 \cdot G_1 + 0 \cdot G_2 = G_1, \\ \text{ite}(0, G_1, G_2) &= 0 \cdot G_1 + 0 \cdot G_2 = 0 \cdot G_1 + 1 \cdot G_2 = G_2, \\ \text{ite}(G_1, G_1, 0) &= G_1 \cdot G_1 + G_1 \cdot 0 = G_1 \cdot G_1 = G_1, \\ \text{ite}(G_1, 1, 0) &= G_1 \cdot 1 + G_1 \cdot 0 = G_1, \\ \text{ite}(G_1, G_2, G_2) &= G_1 \cdot G_2 + G_1 \cdot G_2 = (G_1 + G_1) \cdot G_2 = G_2. \end{aligned}$$

- Expansion formula

$$\text{ite}(\text{ite}(G_1, G_2, G_3), G_4, G_5) = \text{ite}(G_1, \text{ite}(G_2, G_4, G_5), \text{ite}(G_3, G_4, G_5)).$$

- Absorption formula

$$\begin{aligned} \text{ite}(G_1, \text{ite}(G_1, G_2, G_3), G_4) &= \text{ite}(G_1, G_2, G_4), \\ \text{ite}(G_1, G_2, \text{ite}(G_1, G_3, G_4)) &= \text{ite}(G_1, G_2, G_4). \end{aligned}$$

- Changed-order formula

If  $\text{index}(G_2) < \text{index}(G_1) \leq \text{index}(G_3)$ , then  
 $\text{ite}(G_1, G_2, G_3) = \text{ite}(G_2, \text{ite}(G_1, 1, G_3), \text{ite}(G_1, 0, G_3)).$   
 If  $\text{index}(G_3) < \text{index}(G_1) \leq \text{index}(G_2)$ , then  
 $\text{ite}(G_1, G_2, G_3) = \text{ite}(G_3, \text{ite}(G_1, G_2, 1), \text{ite}(G_1, G_2, 0)).$   
 If  $\text{index}(G_2) \leq \text{index}(G_3) < \text{index}(G_1)$ , then  
 $\text{ite}(G_1, G_2, G_3) = \text{ite}(G_2, \text{ite}(G_3, 1, G_1), \text{ite}(G_3, \text{ite}(G_1, 0, 1), 0)).$   
 If  $\text{index}(G_3) < \text{index}(G_2) < \text{index}(G_1)$ , then  
 $\text{ite}(G_1, G_2, G_3) = \text{ite}(G_3, \text{ite}(G_2, 1, \text{ite}(G_1, 0, 1)), \text{ite}(G_2, G_1, 0)).$

The BDD method does not analyse the FTA directly, but it converts the tree to the Boolean equations that will provide the fault probability of the top event. This conversion presents several problems, where the variable ordering scheme chosen for the construction of the BDD has a great effect on its resulting size (see Fig. 2.3).

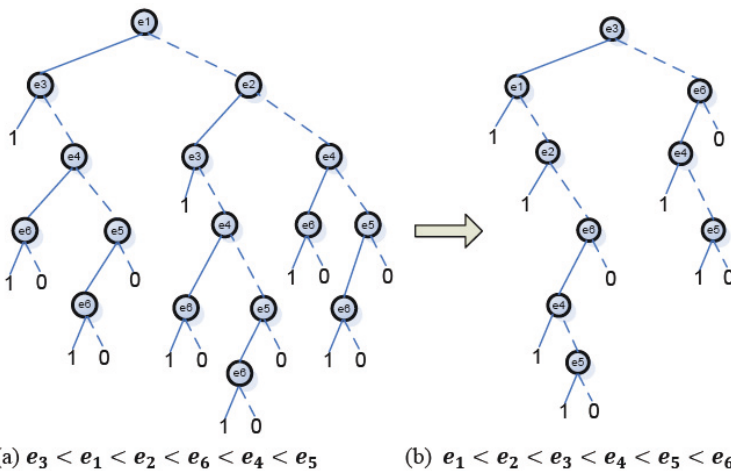

Fig. 2.3 BDDs associated to FT given in Fig. 2.2

It has been demonstrated that the BDD associated to the FT given in Fig. 2.2 (Fig. 2.3a) can be reduced with a better ordering of the events (Fig. 2.3b). The probability of the top event will be the same employing any of the BDDs associated to the FT (Fig. 2.2), i.e. the computational cost will depend on the ranking of the events where the probability of the top event will always be the same.

### 2.4 Ranking Criteria

The level in any event is understood as the number of gates that has higher up the tree until the top event. The “level” method creates the ranking of the events regarding to the level of them. In case that there are two or more events at the same level, the event will have highest priority if it appear early in the tree. Employing the Level method to the FT given in Fig. 2.2, the ranking is showed in Table 2.1.

**Table 2.1** Ranking of the events (Fig. 2.2) by the Level method:  $e_3 < e_2 < e_1 < e_2 < e_5 < e_4$

Basic event	$e_1$	$e_2$	$e_3$	$e_4$	$e_5$	$e_6$	$g_1$	$g_2$	$g_3$	$g_4$
Number of levels	3	3	2	3	3	2	1	1	2	2

Top-down-left-right (TDLM) method generates a ranking of the events by ordering them from the original fault tree structure in a top-down and then left-right manner [2, 3]. In other words, the listing of the events is initialized at each level from a left to right path, where the basic events that are found are added to the ordering list (see Fig. 2.4). In case that any event is encountered, located higher up the tree and already incorporated in the list, then it is not taken into account.

**Fig. 2.4** TDLR method for FT from Fig. 2.2:  $e_3 < e_6 < e_1 < e_2 < e_4 < e_5$

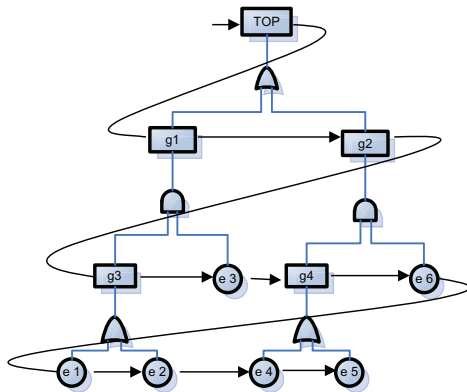

Xie et al [29] suggest by the AND criterion that the importance of the basic event is based on the “and” gates that there are between the  $k$  event and the top event, because in FTA the “and” gates imply that there are redundancies in the system. Consequently, basic events under an “and” gate can be viewed as less important because it is independent to other basic events occurring for the intermediate events [12].

The depth first search (DFS) method goes from top to down of the tree, and each sub-tree from left to right. It is a non-recursive implementation and all freshly expanded nodes are added as last-input last-output process [5]. Fig. 2.5 shows the DFS method applied to the FT from Fig. 2.2.

**Fig. 2.5** DFS approach for the FT shown in Fig. 2.2:  
 $e_3 < e_1 < e_2 < e_6 < e_4 < e_5$

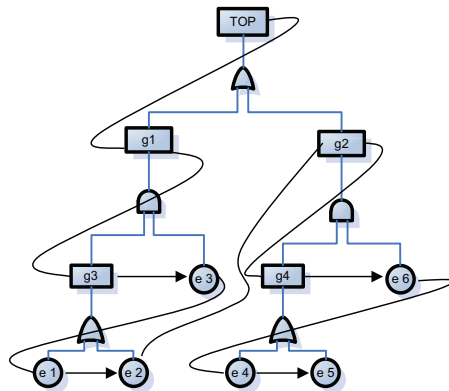

The breadth-first search (BFS) algorithm begins ordering all the descendants events obtained expanding from the standpoint by the first-input first-output (FIFO) procedure (Fig. 2.6). The events not considered are added in a queue list named “open”. It is recalled “closed” list when all the events are considered [6, 11].

**Fig. 2.6** BFS method applied to the FT given in Fig. 2.2:  
 $e_1 < e_2 < e_3 < e_4 < e_5 < e_6$

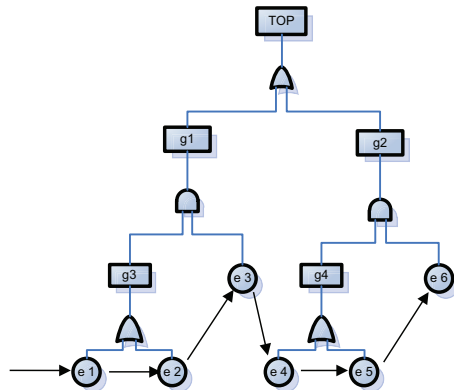

### 2.5 New Ranking Method Approach

A new ranking criterion has been defined in order to reduce the size of the BDD. The following considerations have been taken into account:

Each logic gate from the FT needs an appropriate weighting.

The importance of each event is given by the multiplication of the weighting of the gates crossed from the event considered to the top event.

The basic events are sorted in decreasing values of importance.

The weighting of the logic gate will depend on the type of logic-gate (OR or AND gates), and the number of events under the logic-gate.

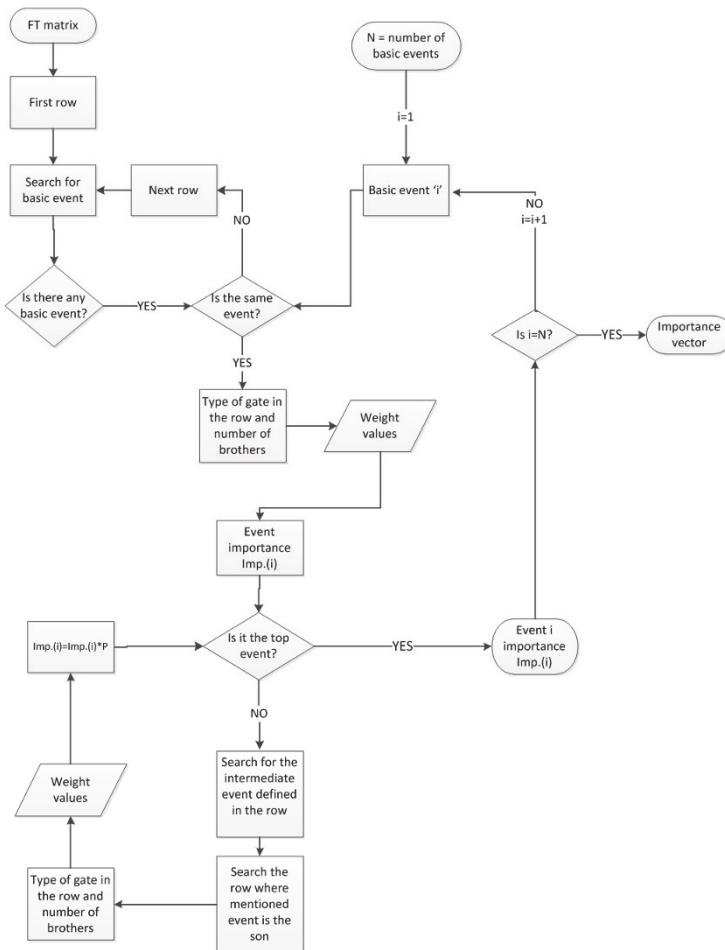

Fig. 2.7 Scheme of the new approach for ranking events

If there is “ $n$ ” events through an AND logic gate, the failure could only be extended through the gate if all the “ $n$ ” events are given, i.e. only 1 state of the  $2^n$ . possible states will be done. The case where the “ $n$ ” events are given is assigned by 1, therefore the weighting of the logic gate will be:

$$P_{\text{and}}(n) = \frac{1}{2^n}.$$

The failure will be extended under any event of the OR gate in all cases where any of the event is not zero, i.e. only one of the  $2^n$ . states will not be extended. The mentioned state is the one in which all the events are 0. Therefore, the OR logic gate weighting is:

$$P_{\text{Or}}(n) = \frac{2^n - 1}{2^n}.$$

The new approach for ranking the events is summarised in the scheme given in Fig. 2.7.

In Fig. 2.8 is presented a FT as an example for ranking the event employing the new approach (Fig. 2.7).

**Fig. 2.8** Weighting of the logic gates by the new ranking method

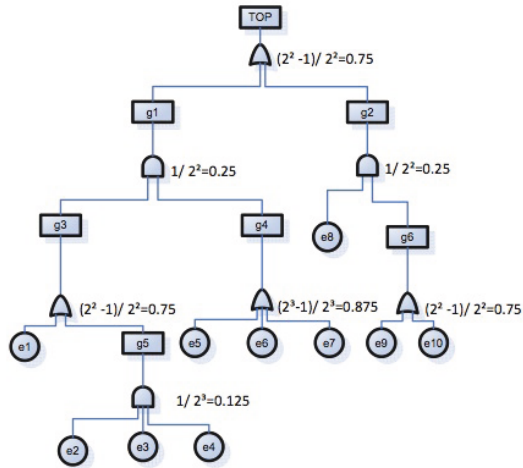

For each basic event, there is a single path to the top event. The importance for event  $e_1$  will be given by all the weights assigned to the gates that are needed to pass through in order to finish to the top event. For example, the importance for the events 1 and 2 (Fig. 2.8) will be:

$$I_{e_1} = 0.75 * 0.25 * 0.75 = 0.140625,$$

$$I_{e_2} = 0.125 * 0.75 * 0.25 * 0.75 = 0.01757813.$$



The importance measurements of the basic events employing the new approach are given in Table 2.2, being the ranking:  $e_8 < e_5 < e_6 < e_7 < e_1 < e_9 < e_{10} < e_2 < e_3 < e_4$ , obtaining 20 cut-sets, where 22 cut-sets are obtained by employing the AND criterion with the ranking  $e_8 < e_1 < e_5 < e_6 < e_7 < e_9 < e_{10} < e_2 < e_3 < e_4$ . The main reason that the new approach provides better results than the AND criterion is because the importance of  $e_1$  is the same to  $e_5, e_6$  and  $e_7$  according to the AND criterion. That means  $e_1$  is more important due to its location in the FT.

**Table 2.2** Importance of basic events

Basic event	$e_1$	$e_2$	$e_3$	$e_4$	$e_5$	$e_6$	$e_7$	$e_8$	$e_9$	$e_{10}$
Importance	0.1406	0.0176	0.0176	0.0176	0.1641	0.1641	0.1641	0.1875	0.1406	0.1406

The new method approach considers that  $e_5, e_6$  and  $e_7$  are connected by an OR logic gate, which means that the failure is more probable to happen through it, i.e.  $e_5, e_6$  and  $e_7$  are given more importance than  $e_1$ .

## 2.6 Results

A set of FTs has been considered for evaluating the ranking events. The number of basic events, intermediate or middle events (the events between the top event and the event considered), OR and AND gates and levels have been taken into account in each FT, and presented in Table 2.3.

**Table 2.3** FTs characteristics

	Number of basic events	Number of middle events	Number of OR gates	Number of AND gates	Number of levels
FT 1	5	5	3	3	3
FT 2	15	13	10	4	8
FT 3	11	9	5	5	6
FT 4	25	21	16	6	12
FT 5	20	15	10	6	5
FT 7	10	7	7	1	5
FT 8	20	17	12	6	11
FT 9	31	25	16	10	11

The methods described above have been employed for ranking the events of the FTs showed in Table 2.3. The numbers of cut-sets given by the methods are given in Table 2.4.

BFS provides poor results in most of the cases, especially when the fault tree has a large number of events, levels and “or” and “and” gates. The Level and AND

**Table 2.4** Cut-sets obtained by the ranking events

	TDLR	DFS	BFS	Level	AND	Approach
FT 1	2	2	2	2	2	2
FT 2	30	30	155	30	30	30
FT 3	12	24	36	12	12	12
FT 4	64	142	176	64	22	28
FT 5	99	207	257	99	55	55
FT 6	9	7	7	9	9	12
FT 7	9	12	21	9	9	9
FT 8	44	76	192	44	44	44
FT 9	1012	1292	3456	1012	1012	924

methods generate the ranking of the events with a minimal cut-sets. The conclusions regarding to Level, DFS and TDLR methods should be studied for each fault tree.

The new approach proposed in this paper provides the minimal cut-sets in most of the cases, i.e. for FT 1-3, 5, 7-9, being the number of cut-sets close to the minimal cut-sets found for FT 4 and 6. The new approach could improve the minimal cut-sets for FT 9, the most complex FT taken into account.

## 2.7 Conclusions

Decision making in maintenance management requires methods and procedures in order to solve the multiple conflicting criteria. This paper presents the Fault Tree Analysis (FTA) for supporting decision-making criteria in maintenance management.

Fault Tree (FT) is the logical relation between the events by a graph that leads the qualitatively analysis. In order to study the FT quantitatively is needed to determine all the cut-sets, or combinations of the events, that may cause the system failure.

Binary Decision Diagrams (BDD) are used in this research work to minimise the computational cost for the quantitatively FTA, where the the Boolean functions are represented by the BDD as a directed acyclic graph. The ranking of the events employed in the BDD will determinate the size of the cut-sets. The “Level”, “Top-Down-Left-Right”, “AND”, “Depth-First Search” and “Breadth-First Search” methods have been considered for listing the events. A new ranking approach is proposed in this paper and a comparative analysis of the methods has been done.

The Level and AND methods create the listing of the events that provide a reduced number of cut sets. The Level, Depth-First Search and Top-down-Left-Right methods should be studied for each FT. Finally the Breadth-First Search is the ordering method that provides a higher cut sets number.

The minimal cut-sets in most of the cases are found by the new approach proposed in this paper. The new approach could improve the minimal cut-sets found in the most complex FT considered.

**Acknowledgements** This work has been supported by the Spanish Ministry of Economy and Competitiveness, under Research Grant No. IPT-2012-0563-120000.

## References

1. Moret BME (1982) Decision trees and diagrams. *Computing Surveys* 14:413–416
2. Burrus CS, McClellan JH, Oppenheim AV et al (1994) Computer-based exercises for signal processing using matlab. Prentice-Hall, Englewood Cliffs, NJ 43–59
3. Lee CY (1959) Representation of switching circuits by binary decision diagrams. *Bell System Technology* 38:985–999
4. Garcia MFP, Vaibhav S, Mayorkinos P (2011) A review of wind turbine maintenance management procedure. In: *Proceedings of the Eighth International Conference on Condition Monitoring and Machinery Failure Prevention Technologies*
5. Giebel G, Oliver G, Malcolm M et al (2006) Common access to wind turbines data for condition monitoring. Riso National Laboratory. In: *Proceedings of the 27th Riso International Symposium on Material Science, Denmark* 157–164
6. Lambert HE (1975) Measures of importance of events and cut sets. *SIAM, Reliability and Fault Tree Analysis* 77–100
7. Andrews JD, Moss TR (1993) *Reliability and risk assessment*. Longman Scientific & Technical, Longmans
8. Bartlett LM (2003) Progression of the binary decision diagram conversion methods. In: *Proceedings of the 21st International System Safety Conference, August 4-8, 2003, Ottawa* 116–125
9. Bartlett LM, Andrews JD (2001) Comparison of two new approaches to variable ordering for binary decision diagrams. *Quality and Reliability Engineering International* 17(3):151–158
10. Xie M, Tan KC, Goh KH et al (2000) Optimum prioritisation and resource allocation based on fault tree analysis. *International Journal of Quality & Reliability Management* 17(2):189–199
11. Cozens NJ, Watson SJ (2003) State of the art condition monitoring techniques suitable for wind turbines and wind farm applications, Report for CONMOW project
12. Bryant RE (1986) Graph-based algorithms for Boolean functions using a graphical representation. *IEEE Transactions on Computing* C-35(8):677–691
13. Akers SB (1978) Binary decision diagrams. *IEEE Transactions on Computing* 27:509–516
14. Watson SJ, Infield DG, Xiang J (2008) Condition monitoring of wind turbines C measurements and methods. *IET Renewable Power Generation*
15. Malik S, Wang AR, Brayton RK, Vincentelli AS (1988) Logic verification using binary decision diagrams in a logic synthesis environment. In: *Proceedings of the IEEE International Conference on Computer Aided Design, ICCAD 88, Santa Clara CA, USA* 6–9
16. Jinglun Z, Quan S (1998) Reliability analysis based on binary decision diagrams. *Journal of Quality in Maintenance Engineering* 4(2):150–161
17. Birnbaum ZW (1969) On the importance of different components in a multicomponent system. *Multivariate Analysis* 581–592
18. Akers SB (1978) Binary decision diagrams. *IEEE Transactions on Computing* 27:509–516
19. Bartlett LM (2003) Progression of the binary decision diagram conversion methods. In: *Proceedings of the 21st International System Safety Conference, August 4-8, 2003, Ottawa, Westin Hotel* 116–125
20. Bartlett LM, Andrews JD (2001) Comparison of two new approaches to variable ordering for binary decision diagrams. *Quality and Reliability Engineering International* 17(3):151–158
21. Bryant RE (1986) Graph-based algorithms for Boolean functions using a graphical representation. *IEEE Transactions on Computing* C-35(8):677–691
22. Cormen TH, Leiserson CE, Rivest RL et al (2001) *Introduction to algorithms*, second edition. MIT Press and McGraw-Hill, ISBN 0-262-03293-7, Section 22.3: Depth-first search 540–549

23. Jensen R, Veloso MM (2000) OBDD-based universal planning for synchronized agents in non-deterministic domains. *Journal of Artificial Intelligence Research* 13:189–226
24. Jinglun Z, Quan S (1998) Reliability analysis based on binary decision diagrams. *Journal of Quality in Maintenance Engineering* 4(2):150–161
25. Lee CY (1959) Representation of switching circuits by binary decision diagrams. *Bell System Technology* 38:985–999
26. Malik S, Wang AR, Brayton RK et al (1988) Logic verification using binary decision diagrams in logic synthesis environment. In: *Proceedings of the IEEE International Conference on Computer Aided Design, ICCAD'88, Santa Clara CA, USA* 6–9
27. Moret BME (1982) Decision trees and diagrams. *Computing Surveys* 14:413–416
28. Jensen RM, Bryant RE, Veloso MM (2002) SetA\*: An efficient BDD-based heuristic search algorithm. In: *Proceedings of AAAI-2002, Edmonton, Canada*
29. Xie M, Tan KC, Goh KH et al (2000) Optimum prioritisation and resource allocation based on fault tree analysis. *International Journal of Quality & Reliability Management* 17(2):189–199