

Eugene Rosenberg
Editor-in-Chief

Edward F. DeLong
Stephen Lory
Erko Stackebrandt
Fabiano Thompson
Editors

The Prokaryotes

Applied Bacteriology
and Biotechnology

Fourth Edition

The Prokaryotes

Eugene Rosenberg (Editor-in-Chief)

Edward F. DeLong, Stephen Lory, Erko Stackebrandt and Fabiano Thompson (Eds.)

The Prokaryotes

Applied Bacteriology and Biotechnology

Fourth Edition

With 132 Figures and 63 Tables

Editor-in-Chief

Eugene Rosenberg
Department of Molecular Microbiology and Biotechnology
Tel Aviv University
Tel Aviv, Israel

Editors

Edward F. DeLong
Department of Biological Engineering
Massachusetts Institute of Technology
Cambridge, MA, USA

Fabiano Thompson
Laboratory of Microbiology, Institute of Biology, Center for
Health Sciences
Federal University of Rio de Janeiro (UFRJ)
Ilha do Fundão, Rio de Janeiro, Brazil

Stephen Lory
Department of Microbiology and Immunology
Harvard Medical School
Boston, MA, USA

Erko Stackebrandt
Leibniz Institute DSMZ-German Collection of Microorganisms
and Cell Cultures
Braunschweig, Germany

ISBN 978-3-642-31330-1 ISBN 978-3-642-31331-8 (eBook)
ISBN 978-3-642-31332-5 (print and electronic bundle)
DOI 10.1007/978-3-642-31331-8
Springer Heidelberg New York Dordrecht London

Library of Congress Control Number: 2012955035

3rd edition: © Springer Science+Business Media, LLC 2006

4th edition: © Springer-Verlag Berlin Heidelberg 2013

This work is subject to copyright. All rights are reserved by the Publisher, whether the whole or part of the material is concerned, specifically the rights of translation, reprinting, reuse of illustrations, recitation, broadcasting, reproduction on microfilms or in any other physical way, and transmission or information storage and retrieval, electronic adaptation, computer software, or by similar or dissimilar methodology now known or hereafter developed. Exempted from this legal reservation are brief excerpts in connection with reviews or scholarly analysis or material supplied specifically for the purpose of being entered and executed on a computer system, for exclusive use by the purchaser of the work. Duplication of this publication or parts thereof is permitted only under the provisions of the Copyright Law of the Publisher's location, in its current version, and permission for use must always be obtained from Springer. Permissions for use may be obtained through RightsLink at the Copyright Clearance Center. Violations are liable to prosecution under the respective Copyright Law.

The use of general descriptive names, registered names, trademarks, service marks, etc. in this publication does not imply, even in the absence of a specific statement, that such names are exempt from the relevant protective laws and regulations and therefore free for general use.

While the advice and information in this book are believed to be true and accurate at the date of publication, neither the authors nor the editors nor the publisher can accept any legal responsibility for any errors or omissions that may be made. The publisher makes no warranty, express or implied, with respect to the material contained herein.

Printed on acid-free paper

Springer is part of Springer Science+Business Media (www.springer.com)

Foreword

The purpose of this brief foreword is unchanged from the first edition; it is simply to make you, the reader, hungry for the scientific feast that follows. These 11 volumes (planned) on the prokaryotes offer an expanded scientific menu that displays the biochemical depth and remarkable physiological and morphological diversity of prokaryote life. The size of the volumes might initially discourage the unprepared mind from being attracted to the study of prokaryote life, for this landmark assemblage thoroughly documents the wealth of present knowledge. But in confronting the reader with the state of the art, the Handbook also defines where more work needs to be done on well-studied bacteria as well as on unusual or poorly studied organisms.

This edition of *The Prokaryotes* recognizes the almost unbelievable impact that the work of Carl Woese has had in defining a phylogenetic basis for the microbial world. The concept that the ribosome is a highly conserved structure in all cells and that its nucleic acid components may serve as a convenient reference point for relating all living things is now generally accepted. At last, the phylogeny of prokaryotes has a scientific basis, and this is the first serious attempt to present a comprehensive treatise on prokaryotes along recently defined phylogenetic lines. Although evidence is incomplete for many microbial groups, these volumes make a statement that clearly illuminates the path to follow.

There are basically two ways of doing research with microbes. A classical approach is first to define the phenomenon to be studied and then to select the organism accordingly. Another way is to choose a specific organism and go where it leads. The pursuit of an unusual microbe brings out the latent hunter in all of us. The intellectual challenges of the chase frequently test our ingenuity to the limit. Sometimes the quarry repeatedly escapes, but the final capture is indeed a wonderful experience. For many of us, these simple rewards are sufficiently gratifying so that we have chosen to spend our scientific lives studying these unusual creatures. In these endeavors, many of the strategies and tools as well as much of the philosophy may be traced to the Delft School, passed on to us by our teachers, Martinus Beijerinck, A. J. Kluyver, and C. B. van Niel, and in turn passed on by us to our students.

In this school, the principles of the selective, enrichment culture technique have been developed and diversified; they have been a major force in designing and applying new principles for the capture and isolation of microbes from nature. For me, the “organism approach” has provided rewarding adventures. The organism continually challenges and literally drags the investigator into new areas where unfamiliar tools may be needed. I believe that organism-oriented research is an important alternative to problem-oriented research, for new concepts of the future very likely lie in a study of the breadth of microbial life. The physiology, biochemistry, and ecology of the microbe remain the most powerful attractions. Studies based on classical methods as well as modern genetic techniques will result in new insights and concepts.

To some readers, this edition of *The Prokaryotes* may indicate that the field is now mature, that from here on it is a matter of filling in details. I suspect that this is not the case. Perhaps we have assumed prematurely that we fully understand microbial life. Van Niel pointed out to his students that—after a lifetime of study—it was a very humbling experience to view in the microscope a sample of microbes from nature and recognize only a few. Recent evidence suggests that microbes have been evolving for nearly 4 billion years. Most certainly, those microbes now domesticated and kept in captivity in culture collections represent only a minor portion of the species that have evolved in this time span. Sometimes we must remind ourselves that evolution is actively taking place at the present moment. That the eukaryote cell evolved as a chimera of certain prokaryote parts is a generally accepted concept today. Higher as well as lower eukaryotes evolved in contact with prokaryotes, and evidence surrounds us of the complex interactions between eukaryotes and prokaryotes as well as among prokaryotes. We have so far only scratched the surface of these biochemical interrelationships. Perhaps the legume nodule is a pertinent example of nature caught in the act of evolving the “nitrosome,” a unique nitrogen-fixing organelle. The study of prokaryotes is proceeding at such a fast pace that major advances are occurring yearly. The increase of this edition to four volumes documents the exciting pace of discoveries.

To prepare a treatise such as *The Prokaryotes* requires dedicated editors and authors; the task has been enormous. I predict that the scientific community of microbiologists will again show its appreciation through use of these volumes—such that the pages will become “dog-eared” and worn as students seek basic information for the hunt. These volumes belong in the laboratory, not in the library. I believe that a most effective way to introduce students to microbiology is for them to isolate microbes from nature, that is, from their habitats in soil, water, clinical specimens, or plants. *The Prokaryotes* enormously simplifies this process and should encourage the construction of courses that contain a wide spectrum of diverse topics. For the student as well as the advanced investigator, these volumes should generate excitement.

Happy hunting!

Ralph S. Wolfe
Department of Microbiology
University of Illinois at Urbana-Champaign

Preface

During most of the twentieth century, microbiologists studied pure cultures under defined laboratory conditions in order to uncover the causative agents of disease and subsequently as ideal model systems to discover the fundamental principles of genetics and biochemistry. Microbiology as a discipline onto itself, e.g., microbial ecology, diversity, and evolution-based taxonomy, has only recently been the subject of general interest, partly because of the realization that microorganisms play a key role in the environment. The development and application of powerful culture-independent molecular techniques and bioinformatics tools has made this development possible. The fourth edition of *the Handbook of the Prokaryotes* has been updated and expanded in order to reflect this new era of microbiology.

The first five volumes of the fourth edition contain 34 updated and 43 entirely new chapters. Most of the new chapters are in the two new sections: Prokaryotic Communities and Bacteria in Human Health and Disease. A collection of microorganisms occupying the same physical habitat is called a “community,” and several examples of bacterial communities are presented in the Prokaryotic Communities section, organized by Edward F. DeLong. Over the last decade, important advances in molecular biology and bioinformatics have led to the development of innovative culture-independent approaches for describing microbial communities. These new strategies, based on the analysis of DNA directly extracted from environmental samples, circumvent the steps of isolation and culturing of microorganisms, which are known for their selectivity leading to a nonrepresentative view of prokaryotic diversity. Describing bacterial communities is the first step in understanding the complex, interacting microbial systems in the natural world.

The section on Bacteria in Human Health and Disease, organized by Stephen Lory, contains chapters on most of the important bacterial diseases, each written by an expert in the field. In addition, there are separate general chapters on identification of pathogens by classical and non-culturing molecular techniques and virulence mechanisms, such as adhesion and bacterial toxins. In recognition of the recent important research on beneficial bacteria in human health, the section also includes chapters on gut microbiota, prebiotics, and probiotics. Together with the updated and expanded chapter on Bacterial Pharmaceutical Products, this section is a valuable resource to graduate students, teachers, and researchers interested in medical microbiology.

Volumes 6–11, organized by Erko Stackebrandt and Fabiano Thompson, contain chapters on each of the ca. 300 known prokaryotic families. Each chapter presents both the historical and current taxonomy of higher taxa, mostly above the genus level; molecular analyses (e.g., DDH, MLSA, ribotyping, and MALDI-TOF); genomic and phenetic properties of the taxa covered; genome analyses including nonchromosomal genetic elements; phenotypic analyses; methods for the enrichment, isolation, and maintenance of members of the family; ecological studies; clinical relevance; and applications.

As in the third edition, the volumes in the fourth edition are available both as hard copies and e-books, and as eReferences. The advantages of the online version include no restriction of color illustrations, the possibility of updating chapters continuously and, most importantly, libraries can place their subscribed copies on their servers, making it available to their community in offices and laboratories. The editors thank all the chapter authors and the editorial staff of Springer, especially Hanna Hensler-Fritton, Isabel Ullmann, Daniel Quiñones, Alejandra Kudo, and Audrey Wong, for making this contribution possible.

Eugene Rosenberg
Editor-in-Chief

About the Editors



Eugene Rosenberg (Editor-in-Chief)

Department of Molecular Microbiology and Biotechnology
Tel Aviv University
Tel Aviv
Israel

Eugene Rosenberg holds a Ph.D. in biochemistry from Columbia University (1961) where he described the chemical structures of the capsules of *Hemophilus influenzae*, types B, E, and F. His postdoctoral research was performed in organic chemistry under the guidance of Lord Todd in Cambridge University. He was an assistant and associate professor of microbiology at the University of California at Los Angeles from 1962 to 1970, where he worked on the biochemistry of *Myxococcus xanthus*. Since 1970, he has been in the Department of Molecular Microbiology and Biotechnology, Tel Aviv University, as an associate professor (1970–1974), full professor (1975–2005), and professor emeritus (2006–present). He has held the Gol Chair in Applied and Environmental Microbiology since 1989. He is a member of the American Academy of Microbiology and European Academy of Microbiology. He has been awarded a Guggenheim Fellowship, a Fogarty International Scholar of the NIH, the Pan Lab Prize of the Society of Industrial Microbiology, the Proctor & Gamble Prize of the ASM, the Sakov Prize, the Landau Prize, and the Israel Prize for a “Beautiful Israel.”

His research has focused on myxobacteriology; hydrocarbon microbiology; surface-active polymers from *Acinetobacter*; bioremediation; coral microbiology; and the role of symbiotic microorganisms in the adaptation, development, behavior, and evolution of animals and plants. He is the author of about 250 research papers and reviews, 9 books, and 16 patents.

**Edward F. DeLong**

Department of Biological Engineering
Massachusetts Institute of Technology
Cambridge, MA
USA

Edward DeLong received his bachelor of science in bacteriology at the University of California, Davis, and his Ph.D. in marine biology at Scripps Institute of Oceanography at the University of California, San Diego. He was a professor at the University of California, Santa Barbara, in the Department of Ecology for 7 years, before moving to the Monterey Bay Aquarium Research Institute where he was a senior scientist and chair of the science department, also for 7 years. He now serves as a professor at the Massachusetts Institute of Technology in the Department of Biological Engineering, where he holds the Morton and Claire Goulder Family Professorship in Environmental Systems. DeLong's scientific interests focus primarily on central questions in marine microbial genomics, biogeochemistry, ecology, and evolution. A large part of DeLong's efforts have been devoted to the study of microbes and microbial processes in the ocean, combining laboratory and field-based approaches. Development and application of genomic, biochemical, and metabolic approaches to study and exploit microbial communities and processes is his another area of interest. DeLong is a fellow in the American Academy of Arts and Science, the U.S. National Academy of Science, and the American Association for the Advancement of Science.

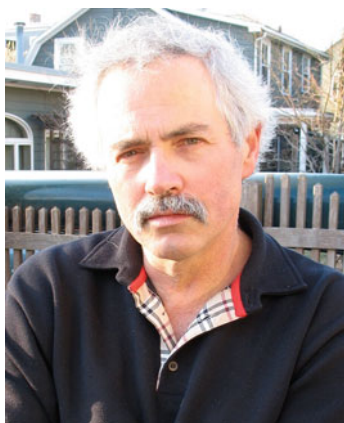

Stephen Lory
Department of Microbiology and Immunology
Harvard Medical School
Boston, MA
USA

Stephen Lory received his Ph.D. degree in Microbiology from the University of California in Los Angeles in 1980. The topic of his doctoral thesis was the structure-activity relationships of bacterial exotoxins. He carried out his postdoctoral research on the basic mechanism of protein secretion by Gram-negative bacteria in the Bacterial Physiology Unit at Harvard Medical School. In 1984, he was appointed assistant professor in the Department of Microbiology at the University of Washington in Seattle, becoming full professor in 1995. While at the University of Washington, he developed an active research program in host-pathogen interactions including the role of bacterial adhesion to mammalian cells in virulence and regulation of gene expression by bacterial pathogens. In 2000, he returned to Harvard Medical School where he is currently a professor of microbiology and immunobiology. He is a regular reviewer of research projects on various scientific panels of governmental and private funding agencies and served for four years on the Scientific Council of Institute Pasteur in Paris. His current research interests include evolution of bacterial virulence, studies on post-translational regulation of gene expression in *Pseudomonas*, and the development of novel antibiotics targeting multi-drug-resistant opportunistic pathogens.

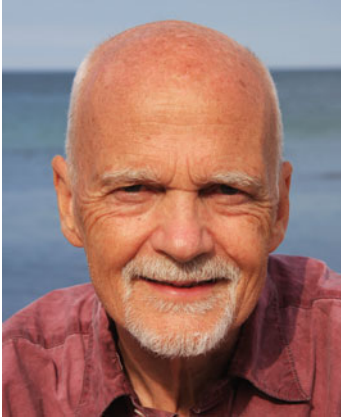
**Erko Stackebrandt**

Leibniz Institute DSMZ-German Collection of Microorganisms and Cell Cultures
Braunschweig
Germany

Erko Stackebrandt holds a Ph.D. in microbiology from the Ludwig-Maximilians University Munich (1974). During his postdoctoral research, he worked at the German Culture Collection in Munich (1972–1977), 1978 with Carl Woese at the University of Illinois, Urbana Champaign, and from 1979 to 1983 he was a member of Karl Schleifer's research group at the Technical University, Munich. He habilitated in 1983 and was appointed head of the Departments of Microbiology at the University of Kiel (1984–1990), at the University of Queensland, Brisbane, Australia (1990–1993), and at the Technical University Braunschweig, where he also was the director of the DSMZ-German Collection of Microorganisms and Cell Cultures GmbH (1993–2009). He is involved in systematics, and molecular phylogeny and ecology of Archaea and Bacteria for more than 40 years. He has been involved in many research projects funded by the German Science Foundation, German Ministry for Science and Technology, and the European Union, working on pure cultures and microbial communities. His projects include work in soil and peat, Mediterranean coastal waters, North Sea and Baltic Sea, Antarctic Lakes, Australian soil and artesian wells, formation of stromatolites, as well as on giant ants, holothurians, rumen of cows, and the digestive tract of koalas. He has been involved in the description and taxonomic revision of more than 650 bacteria taxa of various ranks. He received a Heisenberg stipend (1982–1983) and his work has been awarded by the Academy of Science at Göttingen, Bergey's Trust (Bergey's Award and Bergey's Medal), the Technical University Munich, the Australian Society for Microbiology, and the American Society for Microbiology. He held teaching positions in Kunming, China; Budapest, Hungary; and Florence, Italy. He has published more than 600 papers in refereed journals and has written more than 80 book chapters. He is the editor of two Springer journals and served as an associate editor of several international journals and books as well as on national and international scientific and review panels of the German Research Council, European Science Foundation, European Space Agency, and the Organisation for Economic Co-Operation and Development.

**Fabiano Thompson**

Laboratory of Microbiology
Institute of Biology
Center for Health Sciences
Federal University of Rio de Janeiro (UFRJ)
Ilha do Fundão
Rio de Janeiro
Brazil

Fabiano Thompson became the director of research at the Institute of Biology, Federal University of Rio de Janeiro (UFRJ), in 2012. He was an oceanographer at the Federal University of Rio Grande (Brazil) in 1997. He received his Ph.D. in biochemistry from Ghent University (Belgium) in 2003, with emphasis on marine microbial taxonomy and biodiversity. Thompson was an associate researcher in the BCCM/LMG Bacteria Collection (Ghent University) in 2004; professor of genetics in 2006 at the Institute of Biology, UFRJ; and professor of marine biology in 2011 at the same university. He has been a representative of UFRJ in the National Institute of Metrology (INMETRO) since 2009. Thompson is the president of the subcommittee on the Systematics of Vibrionaceae–IUMS and an associate editor of *BMC Genomics* and *Microbial Ecology*. The Thompson Lab in Rio currently performs research on marine microbiology in the Blue Amazon, the realm in the southwestern Atlantic that encompasses a variety of systems, including deep sea, Cabo Frio upwelling area, Amazonia river-plume continuum, mesophotic reefs, Abrolhos coral reef bank, and Oceanic Islands (Fernando de Noronha, Saint Peter and Saint Paul, and Trindade).

Table of Contents

Applied Bacteriology and Biotechnology	1
1 Organic Acid and Solvent Production: Acetic, Lactic, Gluconic, Succinic, and Polyhydroxyalkanoic Acids	3
<i>Palmer Rogers · Jiann-Shin Chen · Mary Jo Zidwick</i>	
2 Organic Acid and Solvent Production: Butanol, Acetone, and Isopropanol; 1,3- and 1,2-Propanediol Production; and 2,3-Butanediol Production	77
<i>Jiann-Shin Chen · Mary Jo Zidwick · Palmer Rogers</i>	
3 Organic Acid and Solvent Production: Propionic and Butyric Acids and Ethanol	135
<i>Mary Jo Zidwick · Jiann-Shin Chen · Palmer Rogers</i>	
4 Amino Acid Production	169
<i>Hidehiko Kumagai</i>	
5 Microbial Exopolysaccharides	179
<i>Avinash Mishra · Bhavanath Jha</i>	
6 Bacterial Enzymes	193
<i>Wim J. Quax</i>	
7 Diversity and Biotechnological Applications of Prokaryotic Enzymes	213
<i>Alane Beatriz Vermelho · Eliane Ferreira Noronha · Edivaldo Ximenes Ferreira Filho · Maria Antonieta Ferrara · Elba Pinto S. Bon</i>	
8 Bacteria in Food and Beverage Production	241
<i>Michael P. Doyle · Larry R. Steenson · Jianghong Meng</i>	
9 Bacterial Pharmaceutical Products	257
<i>Giancarlo Lancini · Arnold L. Demain</i>	
10 Biosurfactants	281
<i>Eugene Rosenberg · Eliora Z. Ron</i>	
11 Bioremediation	295
<i>Ronald L. Crawford · Eugene Rosenberg</i>	
12 Biodeterioration	309
<i>Ji-Dong Gu · Ralph Mitchell</i>	
13 Microbial Biofilms	343
<i>Dirk De Beer · Paul Stoodley</i>	

14 Biofuels	373
<i>Stefano Freguia · Bernardino Viridis · Korneel Rabaey</i>	
15 The Metabolic Pathways of Biodegradation	383
<i>Lawrence P. Wackett</i>	

List of Contributors

Dirk De Beer

Max-Planck-Institute for Marine Microbiology
Bremen
Germany

Elba Pinto S. Bon

Laboratory of Enzyme Technology, Biochemistry Department
Chemistry Institute, Federal University of Rio de Janeiro (UFRJ)
Rio de Janeiro, RJ
Brazil

Jiann-Shin Chen

Department of Biochemistry
Virginia Polytechnic Institute and State University
(Virginia Tech)
Blacksburg, VA
USA

Ronald L. Crawford

Environmental Biotechnology Institute
University of Idaho
Moscow, ID
USA

Arnold L. Demain

Research Institute for Scientists Emeriti
Drew University
Madison, NJ
USA

Michael P. Doyle

Department of Food Science & Technology
University of Georgia
Griffin, GA
USA

Maria Antonietta Ferrara

Medicines and Drugs Technology Institute
Oswaldo Cruz Foundation
Rio de Janeiro, RJ
Brazil

Edivaldo Ximenes Ferreira Filho

Laboratory of Enzymology, Department of Cellular Biology
Federal University of Brasilia (UNB)
Brasilia
Brazil

Stefano Freguia

Advanced Water Management Centre
The University of Queensland
Brisbane
Australia

Ji-Dong Gu

School of Biological Sciences
Faculty of Science
The University of Hong Kong
Hong Kong SAR

Bhavanath Jha

Discipline of Marine Biotechnology and Ecology
CSIR-Central Salt and Marine Chemicals Research
Institute (CSIR-CSMCRI)
Bhavnagar, Gujarat
India

Hidehiko Kumagai

Ishikawa Prefectural University
Nonoichi-shi, Ishikawa-ken
Japan

Giancarlo Lancini

Fondazione Istituto Insubrico Ricerca per la Vita (FIIRV)
Milan
Italy

Jianghong Meng

Department of Nutrition and Food Science
University of Maryland
College Park, MD
USA

Avinash Mishra

Discipline of Marine Biotechnology and Ecology
CSIR-Central Salt and Marine Chemicals Research
Institute (CSIR-CSMCRI)
Bhavnagar, Gujarat
India

Ralph Mitchell

Laboratory of Applied Microbiology
School of Engineering and Applied Sciences
Harvard University
Cambridge, MA
USA

Eliane Ferreira Noronha

Laboratory of Enzymology, Department of Cellular Biology
Federal University of Brasilia (UNB)
Brasilia
Brazil

Wim J. Quax

University of Groningen
Groningen
The Netherlands

Korneel Rabaey

Advanced Water Management Centre
The University of Queensland
Brisbane
Australia
and
Laboratory of Microbial Ecology and Technology (LabMET)
Ghent University
Ghent
Belgium

Palmer Rogers***Eliora Z. Ron**

Department of Molecular Microbiology and Biotechnology
Tel Aviv University
Tel Aviv
Israel

Eugene Rosenberg

Department of Molecular Microbiology and Biotechnology
Tel Aviv University
Tel Aviv
Israel

Larry R. Steenson

Dupont Nutrition and Health
New Century, KS
USA

Paul Stoodley

Imaging Center for Genomic Sciences
Allegheny-Singer Research Institute
West Penn Allegheny Health System
Pittsburgh, PA
USA

Alane Beatriz Vermelho

Laboratory of Microbial Peptidases
Institute of Microbiology Paulo de Góes
BIOINOVAR - Biotechnology center, Federal University of
Rio de Janeiro (UFRJ)
Rio de Janeiro, RJ
Brazil

Bernardino Virdis

Advanced Water Management Centre
The University of Queensland
Brisbane
Australia

Lawrence P. Wackett

Department of Biochemistry, Molecular Biology and
Biophysics
BioTechnology Institute
University of Minnesota
St. Paul, MN
USA

Mary Jo Zidwick

Biotechnology Development Center
Cargill, Incorporated
Minneapolis, MN
USA

*Deceased

Applied Bacteriology and Biotechnology

1 Organic Acid and Solvent Production: Acetic, Lactic, Gluconic, Succinic, and Polyhydroxyalkanoic Acids

Palmer Rogers* · Jiann-Shin Chen¹ · Mary Jo Zidwick²

¹Department of Biochemistry, Virginia Polytechnic Institute and State University (Virginia Tech), Blacksburg, VA, USA

²Biotechnology Development Center, Cargill, Incorporated, Minneapolis, MN, USA

General Introduction	4	Research and Development	29
Acetic Acid	5	Microbial Genetics and Strain Improvement	29
Introduction	5	Advances in Fermentation and Separation Technologies	31
Scientific Background	7	Prospects	33
The Aerobic Process	7	New Products and Future Demand for Lactic Acid	33
The Anaerobic Process	9	Competitive Processes	34
Commercial Applications	12	Future Lactic Acid Bacteria	34
Industrial Acetic Acid	12	Gluconic Acid	35
Vinegar Acetic Acid	13	Introduction	35
Research and Development	14	Scientific Background	37
Strain Improvement: <i>Acetobacter</i>	14	Commercial Applications	40
Strain Improvement: Acetogens	15	Uses of Gluconic Acid and Gluconates	40
Process Development: <i>Acetobacter</i>	15	Industrial Production	41
Process Development: Acetogens	16	Areas of Research and Development	42
Extractant Systems for Acetic Acid Recovery	18	Gluconobacter and Acetobacter Strains and Process Development	42
Development of Processes for Production of Calcium Magnesium Acetate	18	<i>Zymomonas mobilis</i> Process for Gluconic Acid and Sorbitol Production	43
Prospects for Bacterial Acetic Acid Production	20	Patents	44
Specialized Product Areas	20	Prospects	45
Acetic Acid Production from Bacteria-Based Processes	21	Succinic Acid	46
Lactic Acid	21	Introduction	46
Introduction	21	Scientific Background	47
Scientific Background	22	Commercial Applications	49
Commercial Applications	26	Research and Development	51
Fermentation	26	Strain Improvement	51
Product Recovery	27	Process Development	53
Application and Uses	28		
Economics	29		

In Memoriam

Palmer Rogers, the lead author of this chapter and the senior author of chapters two and three, envisioned the scope of this work and led the effort to examine critically the past, the present, and the future of industrial production of organic acids and solvents by bacterial fermentation. In 2002, Palmer passed away suddenly, before the completion of the original version of these chapters. Palmer was the one who motivated and shepherded us to join the effort and to ensure the completion of this work. He had a lifelong dedication to education of students and helped them attain the satisfaction that achieving in-depth understanding of science through hard work can bring. Palmer was kind, creative, energetic, and uncompromising in his scientific integrity and will be remembered with fondness by many people whose lives he touched.

*Deceased

Patents and Regulatory Issues	55
Prospects for Succinic Acid Production	55
<i>Polyhydroxyalkanoic Acids</i>	56
Introduction	56
Scientific Background	56
History	56
Chemical Structure	57
Physicochemical Properties	57
PHA-Producing Organisms	57
Physiological Functions of PHAs	59
Biosynthesis	59
Degradation	60
Metabolic Engineering	61
Commercial Applications	62
Production of Biopol	62
Manufacturing Biopol-Based Consumer Products	63
Areas of Research and Development	63
Production of PHA Copolymers	63
Production of Chiral Monomers	64
In Vitro Biosynthesis of PHA	64
Production of PHAs by Genetically Engineered Bacteria	65
Search for Inexpensive Carbon Substrates	65
Production of PHAs by Transgenic Plants	66
Patent and Regulatory Issues	67
Prospects	67

Abstract

The objective of this chapter is to present the ways bacteria are effectively harnessed as biocatalysts to perform the synthesis of bulk organic acids and solvents. Prior to the development of the petroleum-based chemical industry, microbial fermentations of agricultural biomass were a major source of a number of useful bulk organic chemicals. Commercial chemical production often emerged from a much earlier food-processing technology where grains, corns, milks, and fruits were fermented to wines, beers, cheeses, and vinegars. Beginning at the end of the nineteenth century and continuing to the present, specific bacterial strains were selected from nature to produce commercially needed bulk chemicals such as lactic acid, acetic acid, acetone and butanol, and more recently gluconic acid and polyhydroxyalkanoates. Lactic acid currently is produced at very large volumes for a multitude of food and industrial uses. Using the tools of metabolic engineering, bacterial strains are being altered for production of propanediols, butanediol, and succinic acid at higher yields and productivity than are possible using natural strains.

General Introduction

The objective of this chapter is to present the ways bacteria are effectively harnessed as biocatalysts to perform the synthesis

Table 1.1

The major organic acids and solvents produced by prokaryotes

Chapter	Product(s)
1	Acetic acid
1	Lactic acid
1	Gluconic acid
1	Succinic acid
1	Polyhydroxyalkanoic acids
2	Acetone/isopropanol/butanol
2	1,2- and 1-3-propanediol
2	2,3-butanediol
3	Propionic and butyric acids
3	Ethanol

of bulk organic acids and solvents. Prior to the development of the petroleum-based chemical industry, microbial fermentations of agricultural biomass were a major source of a number of useful bulk organic chemicals. Commercial chemical production often emerged from a much earlier food-processing technology where grains, corns, milks, and fruits were fermented to wines, beers, cheeses, and vinegars. Beginning at the end of the nineteenth century and continuing to the present, specific bacterial strains were selected from nature to produce commercially needed bulk chemicals such as lactic acid, acetic acid, acetone and butanol, and more recently gluconic acid and polyhydroxyalkanoates. With the advent of genetic engineering, bacterial strains are being altered for production of propanediols, butanediol, and succinic acid at higher yields and productivity than are possible using natural strains.

Table 1.1 lists a selected number of organic acids and solvents (covered in detail in Chapters 1 to 3) produced by prokaryotes. The topical products are selected based on the following properties of the production process that are either well known or under development:

1. Bacteria-catalyzed processes convert cheap biomass into the desired products at high yield and low cost.
2. Downstream separation and purification technologies have been applied successfully to the process.
3. The product, as a commodity chemical, has diverse applications and the promise of a strong future market.

Each section includes the following information about the product:

1. Introduction and history of the process
2. Scientific background such as microbiological principles, physiology, biochemistry, genetics, and product chemistry
3. Commercial fermentation and bioprocess technologies, economics, and competitive processes
4. Research and development, such as approaches to strain improvement and new process technologies

5. Patent and regulatory issues
6. Prospects for the process and
7. A reference list

In today's world, the biotechnology industry, which includes the bacterial production of compounds listed in [Table 1.1](#), accounts for a mere US \$30 billion in chemical compounds produced by fermentation or other bioconversion processes. The total chemical market is greater than US \$1,200 billion (Wilke 1995), which includes all organic chemicals mostly produced from petroleum, natural gas, and coal feedstocks. Indeed, most of the organic acids and solvents listed in [Table 1.1](#) are also synthesized today by chemical processes from these nonrenewable feedstocks. An exception is the polyhydroxyalkanoates, produced only by bacteria. However, cheap, petroleum-derived plastic polymers dominate the present-day market where the polyalkanoate products are designed to compete.

With this situation in mind, what are the needs for and advantages of developing processes for producing fermentation-derived bulk organic acids and solvents? As the cost of nonrenewable feedstocks increases, the need for production of these high-volume organic chemicals from renewable alternative feedstocks is growing. For example, acetic acid, acetone, and isopropanol are on the list of the top 50 organic chemicals produced worldwide (Wilke 1995), and today, they are largely products of chemical synthesis. However, there are active research efforts to develop new technologies to reduce costs in fermentation, bioconversion, and downstream processing—subjects to be covered in the following sections of this chapter. For producing essential organic acids and solvents, these efforts have the potential of adding a product stream based on renewable resources to existing chemical synthesis routes. In this chapter, the best example of a bulk process with this potential is the production of bioethanol from agricultural biomass and even municipal wastes. At present, however, the role of bacterial systems in bioethanol production is relatively minor.

Biosynthetic routes often have product-specific advantages over chemical synthesis, which are important for extending and adding value to some bulk products listed in [Table 1.1](#). For example, optically active compounds, such as lactic acid, can be produced as either L- or D-lactic acid employing specific species of lactobacilli as biocatalysts, whereas chemical synthesis produces a racemic mixture of D, L-lactic acid. Specific properties of polylactide polymers and chemical derivatives of lactic acid differ importantly depending upon the chirality of the monomer (stereospecificity).

Biodegradability of final products such as plastic bottles and films has become an important environmental concern. Where biodegradability is a desirable property, polyhydroxyalkanoate- and polylactide-based plastics produced from bacterial processes are under development for replacement of poorly biodegradable polyvinyl, polyethylene, and other petroleum-based plastics.

As the world population increases beyond the six-billion mark, urban, food processing, and agricultural wastes become

an overwhelming problem. However, microbiologists and bioprocess engineers have developed processes for utilizing wastes as alternative feedstocks. An example is the production of the deicer Ca-Mg-acetate from gasified municipal solid wastes or from waste cheese whey by bacterial fermentation covered in section [“Acetic Acid”](#) of this chapter. A second example is the planned facility for conversion of waste bagasse from sugarcane refineries into millions of gallons of ethanol by bacterial fermentation (McCoy 1998). Thus, the future of bioethanol production from waste biomass may well depend upon development of bacterial fermentations.

Using genetically altered bacteria, chemical companies are developing single-step fermentation/conversion processes for carrying out multistep synthesis of bulk solvents or organic acids. Bacteria-catalyzed conversions of glucose into 1,2- or 1,3-propanediol are examples of processes presently in the experimental stage, which may be developed commercially in the future (Alpers 1999).

Research into the bacterial production of 2,3-butanediol (see section “2,3 Butanediol Production” in Chapter 2) also has been considerable. The future prospects of large-scale fermentative production of 2,3-butanediol as a fuel or as a major chemical feedstock will depend on the need to substitute for present petroleum-based products such as 1,3-butadiene and methyl ethyl ketone (Maddox 1996).

Although the emphasis of this chapter is upon the development of bacteria-based fermentations to produce organic acids and solvents, we have pointed out the parallel role of fungal-based processes where relevant in some sections. For example, the yeast fermentation is of overwhelming importance in bioethanol production. Yet, the bacterial fermentation route has been developed to play important roles in the future utilization of major carbon sources. On the other hand, the lactic acid fermentation is dominated by bacterial processes, and yet a major commercial project employs a fungal fermentation (see section [“Lactic Acid”](#) in this chapter). Industrial production of gluconates and gluconic acid has been based on *Aspergillus niger* fermentations in the past. Yet, much research and development predicts that fermentations using *Acetobacter methanolicus* and *Zymomonas mobilis* may become dominant in the future.

In the following sections, we try not only to indicate the major bacterial systems developed for the production of the specific organic acids or solvents but also to give a realistic assessment of the relative impact of competing processes.

Acetic Acid

Introduction

Until the late nineteenth century, all acetic acid was derived from the classical process of sugar fermentation to ethyl alcohol followed by a second-stage microbial oxidation to acetic acid. The dilute solution of acetic acid produced by microbial metabolism is called “vinegar.” Wine souring leading to a variety of vinegars has been known as long as the

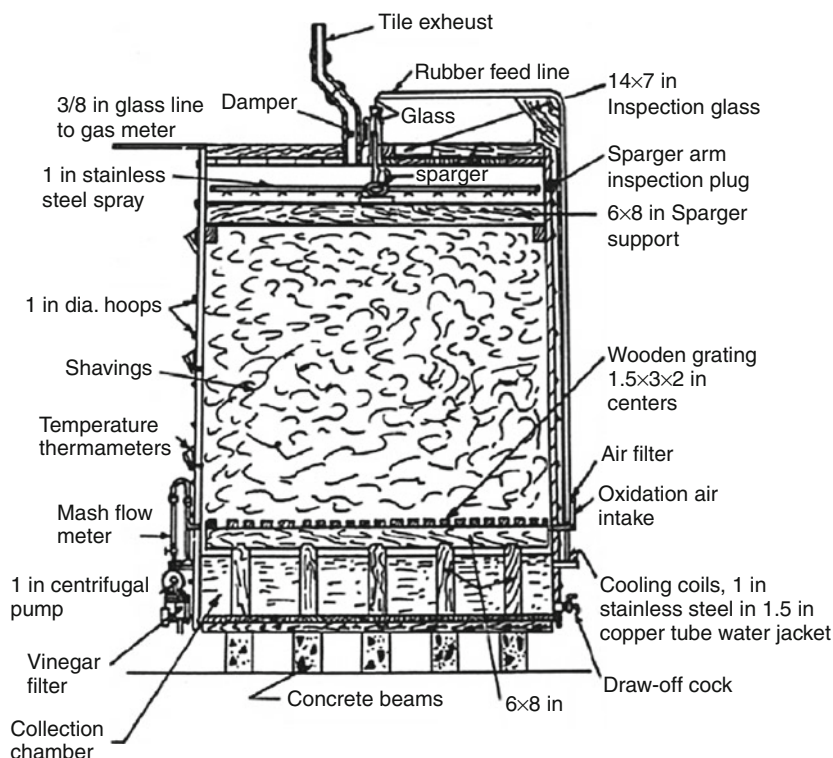

Fig. 1.1

The Frings generator. A typical reactor used in the old method of vinegar production by the “quick process” or the “German process” (From Ghose and Bhadra (1985), with permission)

practice of wine making, probably before 6000 BCE (Nickol 1979). Early Babylonian writings (4000 BCE) report in great detail the production of vinegar and wine from date palms. Vinegar was used early in Babylonian, Greek, and Roman culture for food flavoring, food preservation, pickling, for medicinal purposes such as wound healing, and as a popular drink for soldiers and peasants (Swings 1992). The New Testament reports that Roman soldiers offered Jesus vinegar to drink during the Crucifixion.

A number of natural sugar-containing juices or mashes that are first converted by fermentation to alcoholic solutions can serve as raw materials for vinegar production. The vinegar is named after the original raw material, such as wine vinegar, peach vinegar, apple cider vinegar, rice vinegar, malt vinegar, etc. Until about the early 1950s, most of the world supply of acetic acid was manufactured utilizing the microbial oxidation of raw alcoholic mixtures by a vinegar production process (Ghose and Bhadra 1985). Perhaps the earliest vinegar-manufacturing method was the “slow process,” or “Orleans process,” employed in the Orleans region of France even before the seventeenth century (Allgeier and Hildebrandt 1960). Wooden casks were partly filled with a “good vinegar” as a source of inoculum followed by weekly additions of fresh wine. After 5 weeks, some of the vinegar was replaced by more fresh wine. A thick bacterial mat develops on the surface, known as the “mother of vinegar.” Air was supplied through holes in the cask above the surface of the mat. Thus, a slow, continuous vinegar process was developed.

Vinegar was produced by the Orleans process or French method long before the discovery of the microbial basis for the oxidation of ethanol to acetic acid and, for that matter, the fermentation of sugars to alcohol. In 1732, Herman Boerhaave first suggested the biological nature of the “mother of vinegar”; then, Persoon, in 1822, reported evidence of bacteria in this surface mat and named it “Mycoderma” (Ghose and Bhadra 1985). Kutzing (1837) found that small microscopic organisms in the mother inoculum were necessary for the conversion of alcohol to acetic acid. Pasteur (1868) discovered that the cause of deterioration of wines was due to bacterial contamination during and after the yeast fermentation process, resulting in conversion of alcohol to acetic acid. Almost simultaneously, he made the observation that during vinegar manufacture, similar bacteria, which he called *Mycoderma aceti*, were responsible for production of the acetic acid by oxidation of ethanol. Subsequently, Pasteur showed that partial sterilization or “pasteurization” of wine at 55 °C prevented the spoilage process, and his discovery made him a hero of the French wine industry (Dubos 1988).

The “quick process” or “German process” was invented in the early 1800s. Wine is added at the top of and allowed to trickle through a generator that consists of a tank packed with beech wood shavings. Bacterial cells grow attached to the beech wood shavings and catalyze the conversion of alcohol to acetic acid. Air is blown through holes from the bottom of the tank. In 1929, the “Frings process” was introduced as a major improvement of the quick process (Fig. 1.1). The Frings

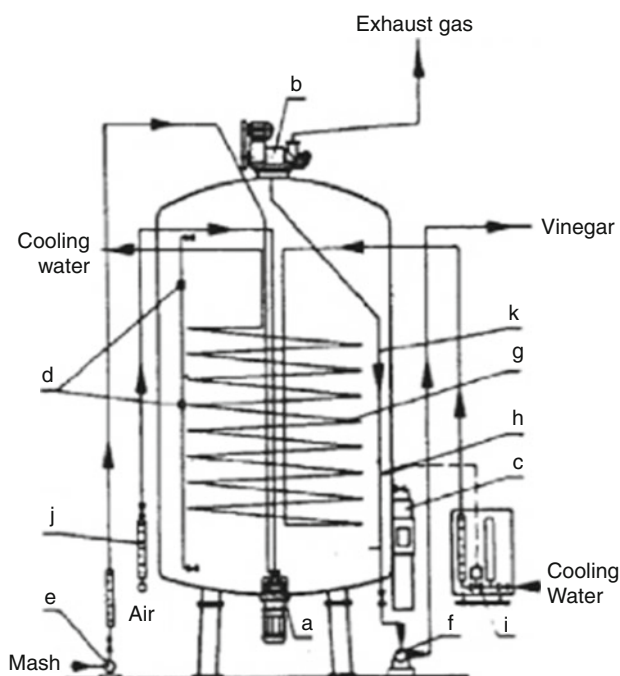

Fig. 1.2
Schematic drawing of the Frings acetator: (a) aerator; (b) defoamer; (c) alkograph; (d) level control switch; (e) mash pump; (f) vinegar pump; (g) cooler; (h) thermometer for temperature control; (i) cooling water valve; (j) airflow meter; (k) return pipe (From Ebner and Follman (1983), with permission)

generator included both forced aerations and temperature control features. This trickle bed process yielded 98% conversion of a 12 % ethanol solution to acetic acid in 5 days. It was also low cost and easy to control.

Hromatke and Ebner introduced the submerged reactor with an aerator fixed at the bottom of the reactor for oxidation of ethanol to acetic acid by *Acetobacter* species (Hromatka and Ebner 1949). Today, the Frings Acetator® is the most common reactor for the production of all types of vinegar by the submerged fermentation method (Ebner et al. 1996). The submerged cultivation reactor (● Fig. 1.2) has the following advantages over the trickling bed reactor for commercial production:

1. Alcohol oxidation to acetic acid is 30 times faster.
2. A smaller total reactor volume is required to achieve a given level of productivity.
3. Between 5 % and 8 % higher yields are obtained.
4. The process is easily automated. It was discovered that *Acetobacter* is very sensitive to short periods of low O₂ levels in submerged culture conditions. Therefore, the success of this process depends upon continuous high rates of aeration of the broth (Agreda and Zoeller 1993).

Most production of acetic acid from dilute sugar solutions is carried out by the two-step vinegar process, using the submerged reactor technology; however, during this decade,

a one-step microbial fermentation of sugar to acetic acid production has been under development (Cheryan et al. 1997). This fermentation is carried out by acetogenic *Clostridium* species and has two major advantages over the two-step vinegar process. First, the fermentation is anaerobic, which saves energy required for aeration during the process; secondly, the single bacterium converts sugar directly and almost stoichiometrically to acetic acid, with a theoretical yield of almost 100 %, which reduces raw material costs. This bioprocess, when developed, may become competitive with chemically produced acetic acid for specific uses, such as calcium magnesium acetate for deicing roadways (Cheryan et al. 1997).

A third biological source of acetic acid is the distillation of wood by a process that was developed in the late nineteenth century (Agreda and Zoeller 1993). It probably provided an additional source of acetic acid up to the early twentieth century.

The first commercial plant for the chemical production of acetic acid came on line in 1916. Clearly, this was the beginning of the expanding market for acetic acid as an important commodity chemical in industry (Agreda and Zoeller 1993). Chemical synthesis of acetic acid is dependent upon petrochemicals from nonrenewable crude oil resources. There are three major processes in use today: oxidation of acetylene-derived acetaldehyde, catalytic butane oxidation, and the carbonylation of methanol (the Monsanto process; Agreda and Zoeller 1993). Production by the Monsanto process provides the major source of glacial acetic acid used in industry worldwide. In the United States, chemical synthesis of acetic acid was reported as 2.34×10^6 t/year in 1995 (Kirschner 1996), which demonstrates the importance of acetic acid as a commodity chemical in industry.

Scientific Background

The Aerobic Process

A two-step microbial process yields a dilute 5–12 % solution of acetic acid (vinegar) from a crude carbohydrate-containing mash. The first step is the production of ethanol from sugars by an anaerobic fermentation, usually by the yeast *Saccharomyces cerevisiae* or alternatively by a bacterium such as *Zymomonas mobilis*



The second step is the oxidative conversion of ethanol to acetic acid carried out by an *Acetobacter* strain. These bacteria catalyze an interesting incomplete oxidation where characteristically their capacity to oxidize ethanol and lactate far exceeds the oxidation of acetic acid to CO₂. During the incomplete oxidation of ethanol, the reducing equivalents are transferred to oxygen:



Surprisingly, the microbiology of the modern vinegar fermentation is not entirely worked out as to the exact taxonomy of the participating *Acetobacter* species. It is still state of the art to

Table 1.2

Acetobacter used in vinegar production

Organism	Properties	References
<i>A. aceti</i>	Vinegar production	Sievers et al. (1994a)
ATCC 15973, 23746	Japan	
IFO 3284		
<i>A. pasteurianus</i>	Vinegar production	Sievers et al. (1994a)
LMG 1635 (formerly <i>A. peroxydans</i>)	Japan	
IFO 3188 and strains		
<i>A. europaeus</i>	Industrial acetators	Sievers et al. (1992)
DSMZ strains	Germany	
LTH strains		
<i>A. lovaniensis</i>	Growth and acetic acid produced at 37–40 °C	Saeki et al. (1997b)
Strains SKU 1108, 1112		

Abbreviations: LMG Laboratory of Microbiology, University of Ghent, Belgium, DSMZ Deutsche Sammlung von Mikroorganismen und Zellkulturen, Braunschweig, Germany, IFO Institute for Fermentation, Osaka, Japan, LTH Institut für Lebensmitteltechnologie, Universität Hohenheim, Stuttgart, Germany, and SKU Faculty of Science, Kasetsart University, Bangkok, Thailand

start a new fermentation process with a “seed vinegar” which is a microbiologically undefined sample drawn from a running Frings Acetator (Ebner et al. 1996). For example, ten strains of *Acetobacter* were isolated from a series of running industrial acetators in southern Germany. Using 16S rRNA oligonucleotide probes to hybridize with DNA from these strains, four strains were identified as members of the *Acetobacter europaeus/xylinum* species; six strains could not be identified as to what species (Sokollek et al. 1998).

Table 1.2 lists some of the identified species of *Acetobacter* that have been isolated from various vinegar production processes. Phenotypic differentiation of *Acetobacter* from the closely related genera *Gluconobacter* and *Frateuria* is presented by Swings (1992).

But regardless of how these *Acetobacter* strains are classified, the vinegar producers' first interest is to use a strain of bacteria that produces a high concentration of acetic acid (12–14 %). Also, the strain chosen must tolerate a high acetic acid concentration, it should require small amounts of nutrients, it should not overoxidize the acetic acid formed, and it should maintain a high productivity (2.5–4 % every 24 h; Ebner and Follmann 1983). There are two reasons for the lack of defined pure starter cultures of preserved strains that embody the desired qualities for commercial acetic acid production. First, the successful preservation and cultivation of isolated production strains have been described only recently (reviewed by Sokollek and Hammes 1997). Secondly, high frequencies of spontaneous mutations in the acetic acid bacteria cause deficiencies in alcohol oxidation, lowered resistance to acetic acid, and loss of other important physiological properties of production strains (Beppu 1993). IS elements have been identified as being the cause for some of these mutational events in *Acetobacter* species (Iversen et al. 1994; Takemura et al. 1991; Kondo and Horinouchi 1997). To avoid the possible selection of mutants in the preparation

of starter cultures, a suggested procedure has been developed (Sokollek et al. 1998). Basically, the pure cultures are isolated on agar plates. A colony is selected, grown, and tested in a pilot acetator to verify high productivity, maximum yield, and tolerance to acetic acid. An aliquot of the test acetator is prepared and frozen or lyophilized as a starter culture (Sokollek and Hammes 1997). After recovery, these cultures were found to be reliable inocula for starting fermentation in pilot acetators.

Oxygen deprivation during acetic acid production by *Acetobacter* in a submerged culture reactor causes rapid loss in productivity. Muraoka et al. (1982) showed that when a submerged reactor with *Acetobacter aceti* reached 6 % acetic acid, blocking aeration for 10 s completely inhibited further acid production. Loss of production was correlated with observed damage to bacterial cells shown by morphologic changes such as irregularly shaped cells. Yet, at less than 4 % acetic acid in the reactor, oxygen limitation for 12 min had little effect on cell appearance or on acid production when aeration was started again. Thus, the sensitivity to oxygen depletion is related to sensitivity of the *Acetobacter* cells to accumulated acetic acid. Further, when all ethanol is used up in an active running acetic acid reactor, the acetic acid bacteria will be irreversibly damaged if addition of fresh ethanol is delayed (Ebner and Follmann 1983). Mesa et al. (1996) modeled the death rate of *A. aceti* due to lack of O₂ in submerged culture as a function of acetic acid concentration. Also, they included data showing the protective effect of increasing concentrations of ethanol.

Apparently, *Acetobacter* is protected from the toxic effects of high concentration of acetic acid by its own ethanol-oxidizing system, through maintenance of pH homeostasis. As the acetic acid concentration increases, the pH outside approaches 2–4, whereas the pH inside the cells must be maintained at pH 6.5–7. Thus, for survival, a ΔpH of 4–2.5 must be maintained very much as for other acidophiles (White 1995).

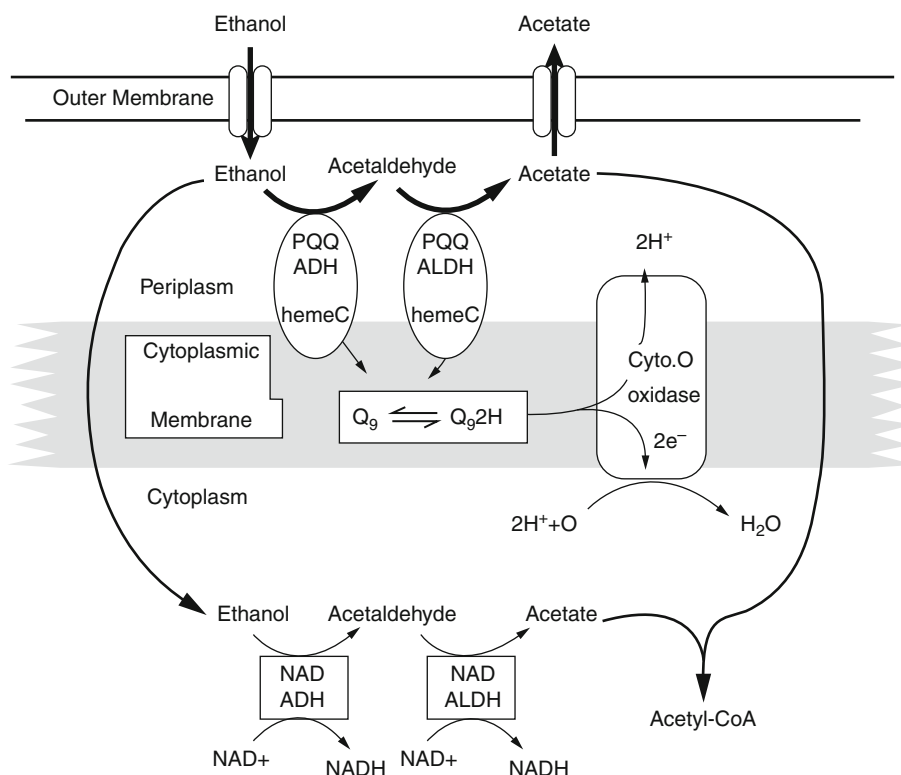

■ Fig. 1.3

Alcohol-oxidizing systems in *Acetobacter* sp. (See text for descriptions. Redrawn from Matsushita et al. (1994), with permission)

The biochemistry and proposed bioenergetics of the alcohol-oxidizing systems together with the alcohol-oxidizing respiratory chains have been elucidated (Matsushita et al. 1994).

The acetic acid bacteria produce acetic acid from ethanol by two enzyme-catalyzed reactions of membrane-bound alcohol dehydrogenase (ADH) and aldehyde dehydrogenase (ALDH). In addition, some acetic acid bacteria can oxidize various sugars and sugar alcohols. These reactions are all “incomplete oxidations” because the oxidation products are usually accumulated in large amounts in the bacterial beers. Both ADH and ALDH have pyrroloquinoline quinone (PQQ) bound as a prosthetic group and are linked to the respiratory chain in the cytoplasmic membrane (Fig. 1.3). A second set of NAD(-P)⁺-dependent ADHs and ALDHs is found in the cytoplasm of acetic acid bacteria. These latter two enzymes have much lower specific activities than those of the PQQ-enzymes and are not involved in acetic acid production (see Fig. 1.3).

The quinoprotein dehydrogenases, ADH-PQQ and ALDH-PQQ, are tightly bound to the periplasmic side of the cytoplasmic membrane. Electrons from alcohol and aldehyde are donated to ubiquinone (Q₉) embedded in the membrane. The ubiquinol oxidase, either cytochrome O (Cyto.O) or cytochrome *a*, transfers electrons from Q₉ and generates an electrochemical proton gradient by reduction of oxygen with 2H⁺ or by pumping H⁺ into the periplasmic space (Fig. 1.3). The major role of this alcohol respiratory system is to maintain homeostasis by consuming cytoplasmic protons and thus balancing the ΔpH. This permits the *Acetobacter* to grow slowly and survive on

ethanol and acetic acid in the presence of high acetic acid concentrations. The observed low biomass yield compared to the high rate of O₂ uptake is supported by experiments with ¹⁴C-ethanol utilization by *A. rancens* (Mori and Terui 1972). The O₂ uptake and ethanol oxidation were in agreement, but the growth yield was only 10 % of that expected compared to other bacteria. Biomass yield was studied with *A. pasteurianus* using an ethanol-limited chemostat with about the same result (Luttik et al. 1997). These workers also measured proton translocation coupled to O₂ uptake for acetate oxidation by the same ethanol-limited cells and found that a very low proton translocation stoichiometry might explain the low biomass yield. Apparently, production strains of *Acetobacter* are selected for very low rates of acetate oxidation. But how acetate oxidation is regulated is still incompletely understood (Saeki et al. 1997a).

The Anaerobic Process

During studies with the anaerobic acetogenic clostridia, it was recognized that these bacteria can ferment sugars such as glucose, fructose, and xylose almost exclusively to acetic acid by the following reactions:



or



Table 1.3

Characteristics of some acetogens

Organism	Optimal growth temperature (°C)	Growth substrates organic	One carbon	References
<i>Clostridium acetivum</i>	30	Fructose, pyruvate, ethanol, and malate	CO ₂ /H ₂ , HCOOH	Adamse (1980)
<i>C. formicoaceticum</i>	37	Fructose, gluconate, galacturonate, glucuronate, lactate, and glycerol	CH ₃ OH/CO ₂	Andreesen et al. (1970)
<i>C. thermoaceticum</i>	60	Glucose, fructose, xylose, and pyruvate	CO ₂ /H ₂ , HCOOH, CO, CH ₃ OH/CO ₂	Fontaine et al. (1942)
<i>C. thermoautotrophicum</i>	60	Fructose, glucose, glycerate, and galactose	CO ₂ /H ₂ , HCOOH, CO, CH ₃ OH/CO ₂	Wiegel et al. (1981)
<i>Acetobacterium woodii</i>	30	Glucose, fructose, pyruvate, glycerol, and 1,2 propanediol	CO ₂ /H ₂ , HCOOH, CO, CH ₃ OH/CO ₂	Balch et al. (1977)
<i>Acetogenium kivui</i>	66	Glucose, fructose and pyruvate	CO ₂ /H ₂ , HCOOH	Leigh et al. (1981)
<i>Sporomusa sphaeroides</i>	34	Ethanol, butanol, and <i>N</i> -methyl compounds	CO ₂ /H ₂ , HCOOH, CH ₃ OH/CO ₂	Möller et al. (1984)
<i>Peptostreptococcus productus</i>	37	Glucose, fructose, xylose, pyruvate and glycerol	CO ₂ /H ₂ , CO	Lorowitz and Bryant (1984)

In 1940, Wieringa described *Clostridium acetivum*, the first acetogenic anaerobic spore-forming bacterium (Adamse 1980). It was discovered to grow on hydrogen and carbon dioxide, forming acetic acid (Braun et al. 1981), according to the following equation:



These organisms have been called “homoacetogens” because on most substrates they produce very little if any organic product, other than acetic acid. Alternatively, Drake (1994) prefers the name “acetogens,” defined as “obligately anaerobic bacteria that can use the acetyl CoA pathway as (1) their predominant mechanism for the reductive synthesis of acetyl CoA from CO₂, (2) their major terminal electron-accepting, energy-conserving process, and (3) their mechanism for the synthesis of cell carbon from CO₂.” Acetogen (as defined above) distinguishes a process by which acetyl CoA rather than acetate is formed as the final product. Also, these bacteria often can produce products other than acetate under certain conditions using alternate pathways (Misoph and Drake 1996). Acetogen (as defined above) also distinguishes these bacteria from the ethanol oxidizers, *Acetobacter* sp. In 1986, the acetogens were represented by 14 different species within five genera, three of which are thermophilic (Ljungdahl 1986). By 1994, there were 40 species classified and 19 unclassified isolates reported (Drake 1994). A selected list is presented in Table 1.3.

In addition to growth on H₂ and CO₂, some acetogens also grow on other one-carbon compounds, such as formate, carbon monoxide, and methanol (Eqs. 1.6–1.10):

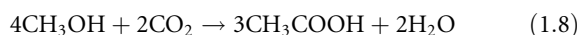
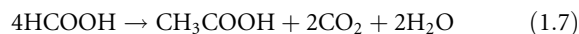

Thus, most of this versatile group of anaerobic organisms can grow on one-carbon compounds as both a sole carbon and energy source (Eqs. 1.6–1.8) or by utilizing energy from the oxidation of H₂ (Eqs. 1.5, 1.9 and 1.10). Acetic acid is the primary product during growth on selected sugars, alcohols, organic acids, or one-carbon compounds.

It is immediately obvious that the fermentation carried out by this group of bacteria (Table 1.3) has three advantages over the aerobic process for acetic acid production using *Acetobacter*. First, this is an anaerobic process, so the energy and equipment costs for providing large amounts of oxygen during the fermentation are unnecessary. Second, the theoretical yield of the anaerobic process is 3 moles of acetic acid per mole of glucose used or 100 %. The theoretical yield of the aerobic process is only 67 % acetic acid per g of glucose because one-third of the carbon is lost as CO₂ (see Eq. 1.2). Third, the ability of some of these bacteria to utilize CO₂ and other one-carbon precursors for growth and acetic acid production permits their use in biological conversion of synthesis gases produced from waste biomass to acetic acid. However, Busche (1991) concluded that the higher acetate concentration tolerated by *Acetobacter suboxydans* used in the aerobic process might outcompete the advantage of the one-step process with the high yield of three acetates per glucose by the anaerobic acetogens.

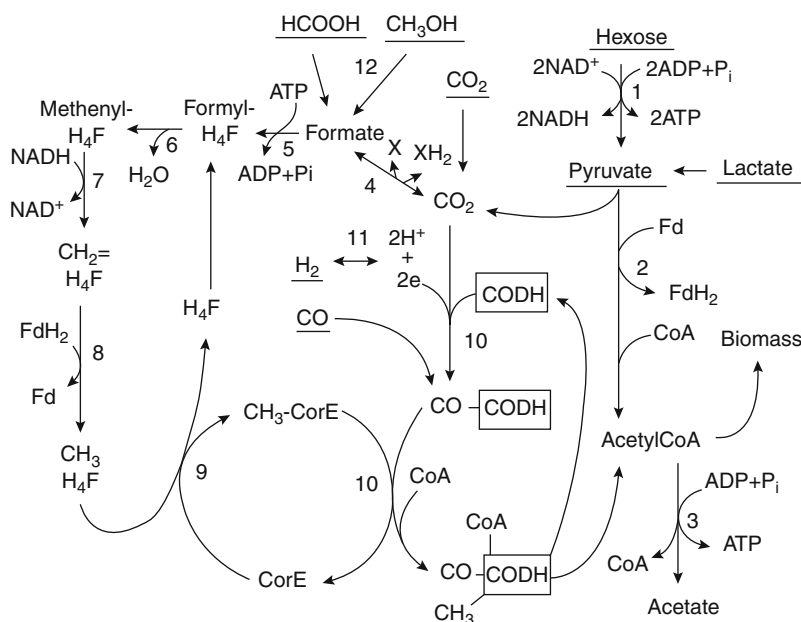

■ Fig. 1.4

Biochemical pathway used by acetogens for fermentation of sugars and utilization of one-carbon precursors for biomass and acetate production: 1 hexose oxidation to pyruvate by the Embden-Meyerhof pathway, 2 pyruvate-ferredoxin oxidoreductase, 3 phosphotransacetylase and acetate kinase, 4 formate dehydrogenase, 5 formate tetrahydrofolate synthetase, 6 methenyltetrahydrofolate cyclohydrolase, 7 methylenetetrahydrofolate dehydrogenase, 8 methylenetetrahydrofolate reductase, 9 methyltransferase, 10 carbon monoxide dehydrogenase (CODH), 11 hydrogenase(s), 12 methanol dehydrogenase and formaldehyde dehydrogenase; Cor-E, corrinoid protein; H_4F , tetrahydrofolate. Underlined compounds are substrates used by various acetogens. The Wood-Ljungdahl pathway consists of reactions 4 through 10

The biochemical pathway that permits the fermentation of glucose to 3 moles of acetate by these bacteria includes the enzyme-catalyzed reactions also essential for the fixation of CO_2 and other one-carbon precursors into cell material. But acetogens do not use the Calvin cycle for CO_2 fixation because the enzyme ribulose diphosphate carboxylase is not present in their cytoplasm. Rather, acetyl CoA is the first intermediate formed during CO_2 or CO fixation by homoacetogenic bacteria. The pathway (now established for both the acetate fermentation and growth on CO_2/H_2) is a combination of the Embden-Meyerhof pathway and the “Wood-Ljungdahl pathway” diagrammed in Fig. 1.4 (Ljungdahl 1986; Drake 1994).

Fermentation of hexose yields two pyruvates, and pyruvate is further oxidized to two acetyl CoA and two CO_2 by the enzyme pyruvate ferredoxin oxidoreductase. Then, the two acetyl CoAs are converted to two acetates. The 4 moles ATP per hexose produced are used for further metabolism. The oxidation-reduction balance is achieved by reduction of both CO_2 molecules to a third acetyl CoA and finally to acetate by the Wood-Ljungdahl pathway. The NADH and reduced ferredoxin generated from the oxidized forms during fermentation of hexose are the source of reducing power. One CO_2 is reduced to 5-methyltetrahydrofolate. The first reaction in this pathway (reaction 4, Fig. 1.4) is the formation of formate catalyzed by an unusual tungsten-selenoprotein formate dehydrogenase (Yamamoto et al. 1983). For *C. thermoaceticum*, the electron donor is NADPH.

The methyl group of 5-methyltetrahydrofolate is transferred through a corrinoid protein intermediate (CH_3 -CorE) to carbon monoxide dehydrogenase (CODH) for the final condensation reaction with coenzyme A and CO to form acetyl CoA (reactions 9 and 10, Fig. 1.4). Also, CODH has been purified and characterized from a number of anaerobic bacteria such as *A. woodii* and *C. thermoaceticum* (Ragsdale 1994). The enzyme from acetogens contains 6 Ni, 3 Zn, and a number of FeS centers. Thus, the primary functions of the CODH of acetogenic bacteria are the reduction of CO_2 to a nickel-bound CO and the synthesis of acetyl CoA. Because the former function is the first step in the synthesis function, it has been suggested that the name of the enzyme should be “methyl-CO-CoA condensing enzyme” or just “acetyl CoA synthase” rather than CODH (Ljungdahl 1986).

During autotrophic growth with CO_2/H_2 (Eq. 1.5) or with reduced one-carbon compounds such as CO, HCOOH, or CH_3OH (Eqs. 1.6–1.8), energy must be derived from H_2 via hydrogenase or alternatively by an enzymatic transfer of electrons from the one-carbon compounds to electron transport proteins. *Clostridium thermoaceticum* contains membrane-bound cytochrome *b*, menaquinone, as well as two rubredoxins and two ferredoxins. *Clostridium thermoaceticum* also has an H^+ -translocating ATPase, indicating that these anaerobes must utilize a proton electrochemical gradient ($\Delta\mu_{H^+}$) created by an electron transport system to produce ATP (Ljungdahl 1994).

This mechanism is essential for ATP synthesis during autotrophic growth inasmuch as the only other source of ATP is acetyl CoA to acetate.

Some acetogens, such as *A. woodii* develop a sodium electrochemical gradient ($D\mu_{\text{Na}^+}$) coupled to acetogenesis from growth with $\text{H}_2 + \text{CO}_2$ rather than a $D\mu_{\text{H}^+}$ formed by *C. thermoaceticum* (Müller and Gottschalk 1994). Experiments with inverted vesicles suggested that the sodium pump is a function of one of the membrane-bound enzymes, methylene- H_4F reductase or the methyltransferase (see Fig. 1.4, reactions 8 and 9). That ATP synthesis is driven by a membrane-bound, Na^+ -translocating ATP synthase was demonstrated in *A. woodii*. Sodium ions also play a major role in the acetogens *A. kivui* and *P. productus* during acetogenesis with H_2 and CO_2 . Homoacetogens growing with sugars can produce adequate ATP from their conversion to pyruvate and then to acetate through acetyl CoA (Fig. 1.4, reactions 1 and 3). However, the observation of high growth yields of some homoacetogens when fermenting sugars together with the observed formation of some hydrogen gas suggests that an electron transport-induced proton gradient may produce additional ATP under fermentation conditions as well.

When acetogens grow on one-carbon compounds using the Wood-Ljungdahl pathway, all cellular carbon compounds must be produced from acetyl CoA (Fig. 1.4). The incorporation of acetyl CoA carbon into lipids, amino acids, nucleotides, carbohydrates, and thus all biopolymers has been demonstrated for *C. thermoaceticum* and *A. woodii* (Eden and Fuchs 1982, 1983). Similar pathways are found for other strict anaerobes such as the sulfur-reducing bacteria growing on acetate and the methanogenic Archaea growing on CO_2 and H_2 or on acetate (Thauer 1989).

The maintenance of pH homeostasis by acetogens during accumulation of acetic acid in the medium has not been carefully studied. The undissociated acetic acid in the medium freely diffuses into the cells where it dissociates into acetate and H^+ dependent on the cytoplasmic pH ($\sim\text{pH}$ 6.0). When the H^+ concentration inside the cell is greater than or equal to the H^+ concentration outside in the medium, then the cell membrane potential is neutralized or reversed. How the acetogen cells deal with this situation is unknown; however, they are tolerant to only about 2.0–3.0 g of acetic acid per liter during batch fermentation. Experiments demonstrate that continuous control of the pH (6.6–6.9) during batch or fed-batch fermentation increases the yield of acetate to 46–56 g/l (reviewed by Wiegel 1994).

The production of acetic acid by acetogens is coupled to growth of their biomass. When growth is rapid, production of acetic acid increases, and when growth is limited or slowed, the production of acetic acid decreases. The nutritional requirements for maximum acetate yield and productivity by *C. thermoaceticum* growing on glucose are reviewed by Cheryan et al. (1997). The optimum concentrations of the metal iron, cobalt, molybdenum, selenite, zinc, and nickel have been determined for maximum growth and acetate production by this bacterium. Cheap sources for the organic nitrogen, which

are required for growth, have been studied for low-cost media development.

The availability of acetogens that are thermophilic (Table 1.3) certainly adds versatility when considering an organism for a production process (Wiegel 1994). Costs of cooling a large volume of medium following sterilization and dissipation of heat generated during mixing and stirring, as well as the risk of contamination by foreign bacteria, are much reduced when operating a commercial-level fermentation system at the higher temperatures of 60–70 °C. Thus, the thermophilic species, *C. thermoaceticum*, *C. thermoautotrophicum*, and *Acetogenicum kivii*, are attractive candidates for new process development.

Commercial Applications

Industrial Acetic Acid

There are two major areas of commercial application of acetic acid today: food-grade vinegar, which is largely the product of bacterial oxidative conversion of diluted purified alcohol or alcoholic mashes from various fruits and grains, and chemically synthesized industrial acetic acid, 62 % of which is produced by carbonylation of methanol and the rest by oxidation of *n*-butane. Chemically synthesized acetic acid is a commodity chemical that has become a major feedstock for the United States and worldwide chemical industry. Figure 1.5 displays the major chemicals derived from acetic acid and their commercial applications.

Petrochemically produced acetic acid reached a level of 4.68×10^9 lbs/year in the United States by 1995 and was ranked 35th in abundance of all chemicals produced (Kirschner 1996). Worldwide production in 1998 was estimated at 11.9×10^9 lbs/year (Layman 1998).

Bioderived acetic acid does not compete economically with acetic acid produced by chemical synthesis. This is because glacial acetic acid is the preferred starting material for most synthetic routes leading to other products. The cost of petroleum-derived 100 % acetic acid by the methanol carbonylation process (Monsanto) is from \$0.15 to \$0.35/lb, whereas the cost of 100 % acetic acid from the *Acetobacter* aerobic oxidation of ethanol is estimated at \$0.35–\$0.45/lb (quoted by Cheryan 1999). The chemical processes have the advantages of initially high acetic acid concentrations (35–45 %) and high production rates. The disadvantages are high cost of catalysts and dependence on nonrenewable petroleum for raw materials.

Industrial acetic acid could be synthesized by either of two microbial processes: (1) from sugars in the two-step vinegar process via ethanol using *Acetobacter* species or (2) from sugars or syngas (CO , H_2 , and CO_2) by the anaerobic fermentation process using *Clostridium thermoaceticum* or related organisms (see section “Scientific Background” in this chapter). These bioprocess routes have the advantage of using a variety of renewable raw materials, which presently are more expensive than petroleum-based resources. The major disadvantage is the

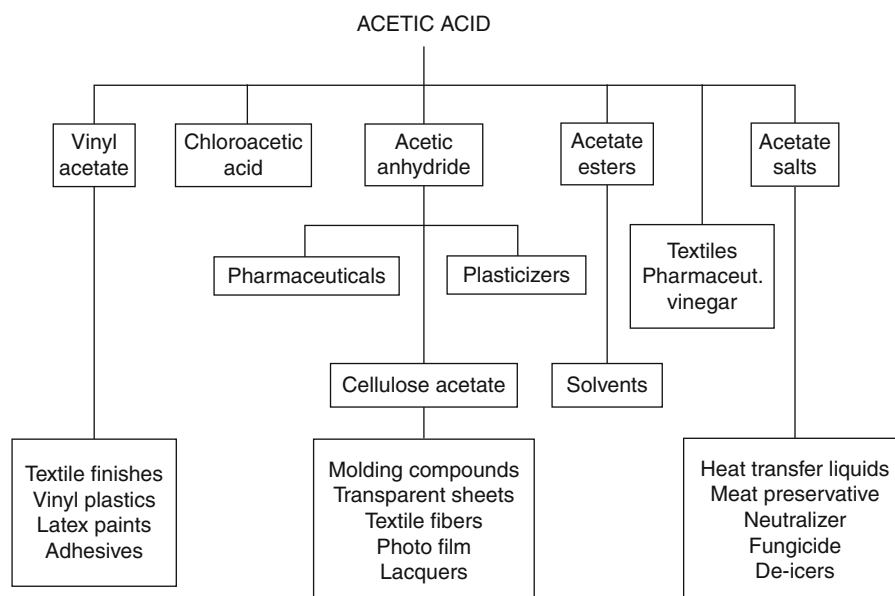

■ Fig. 1.5

Uses of acetic acid. Major commodity chemicals derived directly from acetic acid and commercial products in today's market

cost of recovery of low concentrations of acetic acid (4–12 %) from the fermentation beers, which are mostly water. A great deal of research and development effort is under way to improve the technology of product recovery and improve bacterial strains. These experimental efforts and improvements in the two microbial processes and separation processes are reviewed in the next section (see section [“Areas of Research and Development”](#) in this chapter).

Vinegar Acetic Acid

A submerged fermentation is the most common technique used today for the production of all kinds of vinegar. The Frings Acetator[®] is the best-designed equipment capable of automated operation (Ebner et al. 1996). It is mainly used for production of alcoholic vinegar but also can be used for conversion of alcoholic mashes of fruits and grains. By 1993, more than 600 acetator units were in operation worldwide with a total vinegar production of about 135×10^9 l per year (Ebner et al. 1996).

● [Figure 1.2](#) is a diagram of the Frings Acetator. The Frings Alkograph[®] is an automatic detector that measures the amount of ethanol in the acetator. The Alkograph[®] automatically activates the vinegar discharge pump when the level of ethanol approaches zero. A level switch in the acetator stops this pump and starts the mash pump, which refills the fermenter slowly with fresh mash back to the original volume (Ebner and Follmann 1983). New biosensors and modern membranes have permitted the development of devices, such as the Frings Alkosens[®], that measure alcohol levels without time delay (Ebner et al. 1996).

To produce vinegar with from 12 % to 15 % acetic acid in the acetator, Ebner (1985) developed a semicontinuous process. Each fermentation cycle (about 24–40 h depending on the

conditions) starts with 7–10 % acetic acid and about 5 % ethanol. When the alcohol concentration drops to between 0.05% and 0.3%, a volume of the fermentation beer is rapidly discharged. The acetator is recharged slowly with a volume of new mash containing 0–2 % acetic acid and 12–15 % ethanol, until the starting conditions are again reached. Then, a new cycle begins.

Ebner et al. (1996) reported that since 1994, the single-stage process could be modified to produce vinegar up to 19 % acetic acid. Also, a two-stage process has been developed to produce vinegar with 18.5 % acetic acid (Ebner and Enenkel 1978). Since 1993, vinegar of more than 20 % acetic acid was produced by this process, and an automatic control arrangement for the process has been described (Ebner et al. 1996). The canning industry has a high demand for vinegar with very high acetic acid levels (19–20 %). Thus, the vinegar industry has developed plants that utilize the two-stage submerged fermentation process to produce this product (Ebner and Follmann 1983).

A factory for production of glacial acetic acid using the vinegar process was built in Turkey in 1962. This factory had operated for 20 years before production was discontinued in 1981. It produced 2 t/day of glacial acetic acid from molasses (Ebner and Follmann 1983). The process included alcoholic fermentation of a diluted molasses medium, separation of the purified ethanol, submerged process vinegar production, extraction of acetic acid from vinegar with ethyl acetate, separation of anhydrous acetate from ethyl acetate by distillation, and recovery of the ethyl acetate. Other similar factories erected in other countries have been shut down. The future of such factories depends upon competing oil prices and further developments of the vinegar process.

The total production volume of vinegar output in the European Union and Japan can be fairly well estimated. However, the US vinegar production figures have not been published

since 1987, and production levels in China and Russia are unknown. Excluding China and Russia, a 1996 estimate of worldwide vinegar of 10 % acetic acid is given as about 1.9×10^9 l per year or 190,000 t of pure acetic acid (Ebner et al. 1996).

Research and Development

Strain Improvement: *Acetobacter*

Odd as it may seem, the vinegar industry has always worked with acetic acid bacteria that are not properly characterized. Industrial submerged fermentations are normally started by inoculation with an undefined sample from a previous running fermentation called “inoculation vinegar.” The lack of defined pure starter cultures is due to problems of isolation, cultivation, and preservation of the vinegar bacteria. Entani et al. (1985) developed a double-layer agar technique using an acetic acid-ethanol (AE) medium that permitted cultivation of the *Acetobacter* species capable of producing 10–15 % acetic acid in the commercial acetator. Sievers et al. (1992) and Sokollek and Hammes (1997) have perfected techniques for isolation and cultivation of pure colonies of production strains that now can be preserved and identified. In 1992, Sievers et al. described a new species, *A. europaeus*, claimed to be the major component in industrial vinegar “fermenters” in Central Europe (Sievers et al. 1992). However, using the new isolation technology and hybridization with oligonucleotide probes constructed on the basis of the 16S rDNA sequences published by Sievers et al. (1994a), only four of ten strains isolated from running industrial acetators in Southern Germany were identified as *A. europaeus* (Sokollek et al. 1998). The other six acetic acid bacteria (presumably *Acetobacter* species) could not be identified by hybridization with the DNA probes available. Starter cultures prepared from both an identified (*A. europaeus*) and an unidentified *Acetobacter* strain when inoculated into a pilot acetator achieved the acetate production characteristic of the industrial process. Thus, it is now possible to carry out useful experiments incorporating genetic technology to improve industrial strains of *Acetobacter*.

The desirable characteristics of acetic acid bacterial strains useful to the vinegar industry are tolerance to high concentrations of acetic acid and to “total concentration” (acetic acid + ethanol), requirement for low concentrations of nutrients, absence of acetic acid overoxidation, and high productivity. Genetic techniques have been developed over the past 15 years directed toward strain improvement and understanding of the physiology of these characteristics. Also, the perceived problems of strain stability as well as development of bacteriophage resistance are being addressed. Development of genetic systems for DNA transfer and expression in acetic acid bacteria has been reviewed (Beppu 1993; Fukaya et al. 1992). A great deal of work has resulted in the construction of a number of useful chimeric plasmids composed of *Escherichia coli* vectors and cryptic plasmids from *Acetobacter aceti* or *Gluconobacter suboxydans*. Drug-resistant markers on *E. coli* plasmids, such as resistance to ampicillin, kanamycin,

chloramphenicol, and tetracycline, are expressed in acetic acid bacteria; some of the chimeric plasmids are stable in both hosts without selective pressure. Genetic transformation of acetic acid bacteria has been demonstrated by conjugal transfer from other species of Gram-negative bacteria carrying hybrid conjugal plasmids. In vitro transformation of *A. aceti* by plasmid DNA has been carried out on cells pretreated with calcium ions or polyethylene glycol. Efficiencies of 10^5 transformants per μg plasmid DNA are reported. Electroporative transformation of *A. xylinum* with plasmid DNA is also successful. Insertional inactivation was achieved by transforming a wild-type strain of *A. aceti* using a chimeric plasmid containing a cloned *leuB* gene with an inserted kanamycin resistance gene within the *leuB* sequence. Transformant cells were produced that were both *leuB* negative and KmR. This work demonstrated both gene disruption and a method for foreign gene insertion (insertional inactivation) as a result of homologous recombination in the *A. aceti* host (Okumura et al. 1988). A third method, spheroplast fusion, has been developed for *Acetobacter* strains. After mixing of spheroplasts of two different strains, regeneration of cells yields a fusion frequency of about 10–5. The purpose here is to obtain fused cells that express desired properties of both the “mother strains” (Fukaya et al. 1989).

Cloning and sequencing of the two *Acetobacter* genes for the two membrane-bound dehydrogenases (alcohol dehydrogenase [ADH] and aldehyde dehydrogenase [ALDH]) have been reported. Characterization of these genes in a number of *Acetobacter* species and in *Gluconobacter suboxydans* is still under study (Beppu 1993). In a preliminary report, *A. aceti* showed improved acetic acid production and yield after being transformed with a multicopy plasmid carrying the ALDH gene (▶ Table 1.4). These results suggest that genetic manipulation may lead to improved production strains.

Research on the causes of spontaneous mutation of strains of *A. aceti* and *A. pasteurianus* is under way to determine the nature of the genetic instability of ethanol oxidation during industrial vinegar production. Genetic analysis has implicated

■ Table 1.4
Comparison of acetic acid productivity between two transformants of *Acetobacter aceti* NBI2099

Indicators of production and yield	<i>A. aceti</i> NBI2099 (pMV24) ^a	<i>A. aceti</i> NBI2099 (pAL25) ^a
Acetic acid productivity ^b (g/l/h)	1.8	4.0
Specific growth rate ^c (/h)	0.072	0.142
Maximum acetic acid concentration (g/l)	68.4	96.6

^aPMV 24 is a plasmid vector developed for *Acetobacter*, and pAL25 is the recombinant plasmid which was constructed by inserting a gene encoding the 75-kDa subunit of the ALDH complex of *A. polyoxogenes* into pMN24

^bProductivity is 20 g of acetic acid per liter

^cGrowth rate is 30 g of acetic acid per liter

From Fukaya et al. (1992), with permission

insertion of IS element IS1380 into the ADH gene or into the cytochrome *c* gene as being responsible for some cases of mutation. The direction of research on strain instability and on the genetics of tolerance to acetic acid and ethanol has been reviewed (Beppu 1993).

Strain Improvement: Acetogens

The use of the acetogenic bacteria in the anaerobic process of acetic acid production presents three serious problems. The first major concern is low tolerance to acid. The bacterial species listed in Table 1.3 have been studied in enough detail to indicate that no growth and little acetate production occur at less than pH 4.7. Research over the past 15 years on adaptation or selection of mutants of homoacetogens that tolerate lower pH values has been only partially successful. For example, one strain (mutant C5-3 of *C. thermoaceticum*) grew in continuous culture and (at pH 5.3–5.8) produced up to 3.5–4.5 g of acetic acid/l. Most recent research on mutation and strain selection has concentrated on *C. thermoaceticum* (Wiegel 1994). A promising mutant of *C. thermoaceticum* (ATCC49707 or DSM6867) produced up to 55 g/l, under controlled pH 6.2–6.8, during fed-

batch fermentation of glucose. This strain also tolerated dolime (high-magnesium lime) up to 60 g/l (Parekh and Cheryan 1991, 1994b). This strain is presently under development for production of calcium magnesium acetate (CMA; Cheryan et al. 1997).

The second problem for the acetogenic production process is low productivity. In the batch process, rates of 0.5–0.8 g/l-h are considered unacceptable (Busche 1991). Only technological advances in the fermentation process, covered below, can improve low productivity. The third problem is that the rate of acetic acid production by acetogens is closely coupled with the rate of growth. *Clostridium thermoaceticum* under fed-batch fermentation conditions and with higher acetate-producing mutants seems to exhibit some uncoupled acetic acid production. However, higher yields of acetic acid and decreased biomass waste would result with an increase in growth-uncoupled acetic acid production (Wiegel 1994).

Process Development: Acetobacter

Research on development of the acetic acid production process involves many types of bioreactors. In Table 1.5, the characteristics of some of these experimental bioreactors and

Table 1.5
Comparison of bioreactors for oxidation of ethanol to acetic acid by *Acetobacter*

Bioreactor and process	Acetic acid output (g/l)	Acetic acid productivity (g/l-h)	Stable operation (days)	References
Commercial processes				
Frings acetator, submerged, and semicontinuous	120–150	1.6–2.0	360	Ebner et al. (1996)
Frings generator, trickling, wood shavings, and recycle	110	0.16	>50 ^a	Ebner and Follman (1981)
Continuous, surface, and pellicle	50	0.6	200	Yasui (1958)
Experimental processes				
Cell recycle continuous with hollow fiber filtration	52.4	12.7	11	Park et al. (1989)
	45.7 ^b	10.7	35	Fukaya et al. (1992)
	60.0 ^c	25		
Cell recycle continuous, fed batch, hollow fiber filtration	90	2.67	14	Park et al. (1991)
Surface, shallow flow, and pellicle	57.6	31.7	34	Toda et al. (1989)
Immobilized cells on:				
TiO ₂ H ₂ O	69	5.0	61	Kennedy et al. (1980)
Fluid bed, carrageenan	45	5.0	460	Osuga et al. (1984)
Fixed bed, ceramic	34	4.35	270	Gommidh et al. (1986)
Fluid bed, carrageenan	55	3.43	50	Mori (1993)
Fluid bed, chitosan beads	33	8.28	52	Mori (1993)

^aYears

^bHigh cell density (3 g dry per liter) and dilution rate, 3 h⁻¹

^cCell density (0.8 g dry per liter) and dilution rate, 0.5 h⁻¹

processes are compared to three industrial bioreactors in use for vinegar production. The focus of this research is to develop a process that yields a high production rate with a high exit concentration of acetic acid, while maintaining a long period of stable operation. All of these objectives must be realized if the *Acetobacter* process is to be eventually incorporated into a commercial glacial acetic acid production system that will be competitive with the chemical manufacturing processes. Using the commercial submerged vinegar fermentation with a Frings Acetator in a semicontinuous mode, the process output is 120–150 g of acetic acid/l (▶ [Table 1.5](#)). A 64,000-l unit can produce more than 6,000 lbs of acetic acid in 24 h and is stable for 360 days. The experimental processes listed in ▶ [Table 1.5](#) have achieved much higher productivities than present commercial processes but, in general, sacrifice the high acetic acid output. The cell recycle continuous bioreactors with hollow fiber filtration modules have achieved the highest productivity in the laboratory setting, producing 5–50 times more acetic acid (g/l-h) than the Frings Acetator. However, the output acetic acid is two to three times more dilute (45.7–60 g/l), thus placing the greater burden on the final separation processes.

Park et al. (1991) investigated a semicontinuous reactor with ethanol fed to maintain 20–30 g/l for about 50 h when acetic acid accumulated to about 85–90 g/l (see ▶ [Table 1.5](#)). Oxidation of ethanol slowed to zero at this time, and the cell culture was rapidly recycled through a hollow fiber filter. The concentrated cells were then diluted with fresh medium and a new cycle started. It was found that the *Acetobacter* cells lost much viability, but the nonviable cells continued to oxidize ethanol during the later cycles. A high acetic acid output of about 85–90 g/l was maintained through six cycles or for about 300 h.

Upon scale-up, the engineering of these cell recycle bioreactors promises to be more costly and more complex to operate than the commercial semicontinuous submerged Frings Acetators. The experimental shallow-flow bioreactor is designed to give a continuous horizontal flow of medium under a bacterial film with a large surface area of a few 100 cm². The liquid depth is less than 10 mm, resulting in high oxygen absorption and an acetic acid output of 57.6 g/l (▶ [Table 1.5](#)). This apparatus is technically simple and has been shown to yield very high rates of production of acetic acid (31.7 g/l-h) without the energy required for forced aeration (Toda et al. 1989). Furthermore, the high productivity is dependent on the high surface-to-volume ratio of the shallow liquid flow, and the exit acetic acid concentration (50–66 g/l) does not change very much over a tenfold variation in liquid residence time.

There have been a great many reports of experimental bioreactors based on the immobilized cell technology. Some of these are listed in ▶ [Table 1.5](#). Many difficulties have been encountered with immobilized cell systems such as poor oxygen exchange and breakdown of gels and beads with consequent bleeding of attached bacteria. The advantage of these bioreactors is that the productivity is three to four times that of commercial processes. None of these immobilized approaches has gone beyond the small pilot plant bioreactor stage, and much more

engineering development is necessary for practical commercial application of this technology (Mori 1993).

Research has demonstrated efficient production of acetic acid from glucose in a coculture of *Zymomonas mobilis* and *Acetobacter* strains (Kondo and Kondo 1997). Normally, in the vinegar process, the anaerobic ethanol fermentation is carried out separately from the oxidative conversion of ethanol to acetic acid, which requires highly aerobic conditions. Even though *Z. mobilis* grows and produces ethanol from glucose more rapidly in anaerobic culture and *Acetobacter* spp. grow and produce acetic acid under aerobic conditions, the two organisms in fact can coexist in natural settings such as fermentation of plant juices and beers. Also, both of these bacteria are tolerant to low pH and high ethanol concentrations (Swings and De Ley 1977). The culture of two bacteria with 100 g of glucose/l was initially operated at low aeration and low agitation until the glucose reached 5 g/l, and then, the shift to acetic acid production was started by operating at high aeration. The acetic acid yield from glucose was 0.64 g/g (95.5 % of theoretical), and thus 62–70 g of acetic acid/l was produced in about 60 h in these experiments. Further research and scale-up may yield a coculture method for direct manufacture of acetic acid from inexpensive sources of sugar with acetic acid outputs of 120–150 g/l, similar to production achieved by the Frings Acetator (▶ [Table 1.5](#)).

Process Development: Acetogens

Development of processes for production of acetic acid by the anaerobic acetogenic bacteria has focused mainly on fermentation of sugars. The advantage of these bacteria (such as *C. thermoaceticum*) is that they are homofermentative, with almost quantitative conversion of substrate to acetic acid. However, as outlined above (see section ▶ [“Strain Improvement: Acetogens”](#)), they are sensitive both to high sugar concentration and to inhibition by acid conditions, resulting in limited acetic acid output (less than 20 g/l) in batch culture.

The acid-tolerant mutant of *C. thermoaceticum* ATCC49707 (see section ▶ [“Strain Improvement: Acetogens”](#)) when grown in batch culture with pH controlled at pH 6.3–6.8 showed a much improved acetic acid output of 30–40 g/l and a productivity of 0.3 g/l-h (see ▶ [Table 1.6](#)). Experimental fermentations have been conducted to replace expensive additives like yeast extract (YE) with low-cost nutrients. The best source of nutrients found for sugar fermentation using *C. thermoaceticum* is corn steep liquor (CSL), which has been used in industrial ethanol fermentations and for production of pharmaceuticals. This research is summarized by Cheryan et al. (1997). Because *C. thermoaceticum* and other acetogenic anaerobic bacteria are sensitive to high sugar concentrations, experimental fed-batch mode fermentations resulted in higher acetate outputs (see ▶ [Table 1.6](#)). Here, additional substrate is added as a concentrate at intervals during the fermentation. However, the productivity still remained very low. Continuous fermentation and immobilized whole cell systems have been

Table 1.6

Comparison of experimental bioreactors for acetate production from sugars by acetogenic *Clostridia*

Bioreactor and process ^a	Acetic acid output (g/l)	Acetic acid productivity (g/l·h)	Stable operation (days)	References
Batch with YE	35	0.3		Shah and Cheryan (1995b)
Batch with CSL	30–40	0.19–0.33		Shah and Cheryan (1995a)
Fed-batch with YE	55	0.3		Parekh and Cheryan (1991)
Fed-batch with CSL	39.9	0.2–0.3		Shah and Cheryan (1995b)
Cell recycle continuous, hollow fiber filtration	25–45	0.4–1.7	54	Parekh and Cheryan (1994a)
Cell recycle continuous, two stage, membrane filtration	37.5	0.75	17.5	Shah and Cheryan (1995b)
Cell recycle continuous, with fed batch, draw, and fill	38	0.88	14.6	Shah and Cheryan (1995b)
Immobilized cells, fibrous bed				
Fed batch	78.2	0.95		Huang et al. (1998)
Continuous	12–23	0.38–0.8	?	Huang et al. (1998)

Symbols and abbreviations: ? unknown, YE yeast extract, and CSL corn steep liquor

^aAll results were obtained using *C. thermoaceticum* ATCC47909 fermentation of glucose at pH 6.3–6.8, except for immobilized cell results, which were *C. formicoaceticum* ATCC 27076 fermentation of fructose at pH 7.6

used to increase productivity in acetogenic fermentations (Table 1.6).

Several experimental cell recycle bioreactors using a membrane module as a separation device have been developed that yield up to fivefold greater productivity in anaerobic fermentations (Cheryan et al. 1997; see Table 1.6). Figure 1.6 is a diagram of a continuous cell cycle membrane bioreactor. The reactor is connected in a continuous closed loop with the S ultrafiltration membrane module. Product is removed in the permeate, and feed is added and volume adjusted in the reactor. Because acetate production is “growth associated,” excess cells must be bled from the retentate. The entire system runs at a high cell density permitting the same high output of fed-batch fermentations with four to five times the productivity. These bioreactors have retained stable operation for greater than 50 days (Table 1.6). Experiments with the cell cycle continuous reactors show that (at high dilution rates of 0.03 h^{-1}) the productivity is $1.7 \text{ g/l}\cdot\text{h}$, but the output was only 25 g/l ; at a low dilution rate of 0.007 h^{-1} , productivity dropped to $0.4 \text{ g/l}\cdot\text{h}$, with a high output of 45 g/l . Thus, a compromise must be set dependent on the other process elements. Variations such as the two-stage continuous cell recycle and the continuous cell recycle with fed-batch draw and fill bioreactors are being developed and have both higher output of acetic acid and the higher productivity (see Table 1.6). Acetic acid production from fructose at pH 7.6 by *C. formicoaceticum* immobilized in a fibrous-bed bioreactor is under development. Both fed-batch and continuous processes were examined (Table 1.6). Inasmuch as both a higher maximum production rate

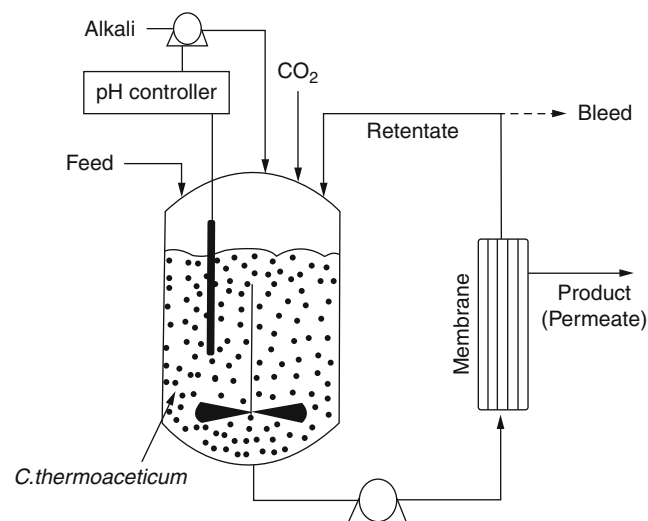

Fig. 1.6 Production of acetic acid from glucose by *Clostridium thermoaceticum* in a continuous bioreactor. The schematic shows the use of membrane separation for product recovery and cell recycle (From Cheryan et al. (1997), with permission)

and higher inhibition rate constant were observed in the fibrous-bed reactor, it was concluded that immobilized cells were less sensitive to acetic acid inhibition than were unattached suspended cells. This improved cell behavior predicts that a fibrous bed reactor may be a tool for adapting these bacteria to acetate tolerance (Huang et al. 1998).

Extractant Systems for Acetic Acid Recovery

Fermentation beers are mostly water with a small amount of acetic acid, usually 1.2–3.5 %. Recovery costs are significant, and they become a major economic consideration for any successful process. The commercial choice for acetic acid recovery has been solvent extraction. Busche (1985) presented an example of an extractive fermentation process along with a cost analysis for a glacial acetic acid plant producing 250×10^6 lbs/year. It is clear from this analysis that recovery costs make up a significant contribution to the overall cost of production. Most important is that product recovery costs are very sensitive to the acetic acid concentration of the fermentation liquor. Busche (1991) compared the economics of manufacture of glacial acetic acid by extractive fermentation using *Acetobacter suboxydans* with extractive fermentation using *Clostridium thermoaceticum*. A model was designed based on continuous production of acetic acid in fluidized bed bioreactors with recycling beginning with corn syrup glucose. The ethanol is prepared from corn syrup by fermentation in a continuous bioreactor using *Zymomonas mobilis*, and the ethanol beer is directly sent to the *Acetobacter* bioreactor after removal of the *Z. mobilis* cells. Even though the *C. thermoaceticum* fermentation of corn syrup glucose has a 90 % yield, the low output of 3.6 % acetic acid results in a higher cost of product purification. The extraction process involves treatment of the broths in a continuous countercurrent multistage extractor using a high-boiling solvent such as trioctylphosphine oxide at 50 % in 2-heptanone (with a K of 2.5 and a low solubility in water of 1 ppm). The extract is then treated in distillation columns to purify the glacial acetic acid product. The entire techno-economic analysis showed that the combined *Acetobacter-Zymomonas* scheme for glacial acetic acid production is slightly less costly than the *Clostridium* direct high-yield fermentation (\$0.38 vs. \$0.42/lb). However, neither was competitive with the price at that time of \$0.29–\$0.31/lb for synthetic glacial acetic acid. Improvements in bioreactor design were covered in the sections above for oxidation of ethanol by *Acetobacter* (see section [“Process Development: Acetobacter”](#) in this chapter) and for sugar fermentation by *Clostridium* (see section [“Process Development: Acetogens”](#) in this chapter). These improvements, which produce a higher acetic acid output at an acceptable productivity when combined with downstream organic extractant methods, may eventually result in glacial acetic acid production from biomass competitive with synthetic acetic acid production. Althouse and Tavlarides (1992) made an analysis of 50 organic extractant systems for acetic acid removal. Two candidate extractants (Adogen 381 [40 % in cyclohexanone] and Adogen 381 [Xy-Mix]) were selected based on a number of criteria. Either was suggested for the extraction of dilute acetic acid from the outflow of a fermenter. The membrane techniques electrodialysis (ED) and nanofiltration (NF) have been found useful for downstream separation and partially concentrating acetates (Cheryan et al. 1997). Several NF membranes were screened for separation of

acetic acids, and the technique appeared to be economically sound for consideration in processing fermentation broths (Han and Cheryan 1996).

Development of Processes for Production of Calcium Magnesium Acetate

The thrust of research and development for production of acetic acid by acetogenic bacteria such as *Clostridium thermoaceticum* and *C. formicoaceticum* is the manufacture of acetate salts. Calcium magnesium acetate (CMA) and potassium acetate (KA) have been approved by the US Federal Highway Administration as environmentally safe and noncorrosive deicers for winter roadways and for airport runways (Yang et al. 1997). Acetate salts are considered a commodity chemical. Presently, CMA is made from petroleum-derived glacial acetic acid at a cost of about \$1,000/t. Two processes for the production of CMA requiring acetogenic bacteria as biocatalysts have been analyzed to demonstrate technical and economic feasibility.

In a demonstration project report (Basu et al. 1999), a process was outlined whereby municipal solid waste (MSW) coal or sewage sludge was converted to syngas (CO, CO₂, and H₂) by well-known technologies. For example, lignocellulosic biomass may be gasified by the approximate reaction:

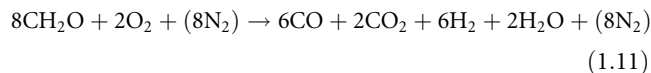

The cooled gas mixture of CO, CO₂, and H₂ was then converted by a new proprietary acetogenic bacterium, ER12, to acetic acid/acetate. As was presented above (see section [“Scientific Background”](#) in this chapter), members of acetogenic bacteria such as *A. kivuii*, *P. productus*, and *A. woodii* produce acetic acid from either CO or H₂ and CO₂ (see [Table 1.3](#)). Strain ER12, isolated by Bioengineering Resources, Inc. (BRI), is a mesophilic acetogen that rapidly utilizes CO, CO₂, and H₂; has a high tolerance to acetate/acetic acid; and can accumulate 15–20 g of product/l at pH 4.5–5.0. Production of acetic acid was tested in a continuous stirred-tank reactor, with both continuous gas and liquid feed, and with cell recycle. The liquid product stream was fed to an extraction column where a solvent (proprietary) extracted acetic acid to a concentration of 50 g/l. Dolime was added to produce CMA, the solvent was separated for recycle, and the CMA water stream was fed to a dryer. [Figure 1.7](#) is a diagram of the process of CMA production from waste biomass.

Economic projections for a facility to produce 100,000 t/year of CMA from MSW were presented. With no charge or credit for the waste materials used, the operating cost with an included 30 % investment return was estimated at \$200/t. This price is less than 28 % of the price of the CMA deicer.

Also, a detailed process has been developed for the production of CMA from cheese whey lactose (Yang et al. 1999).

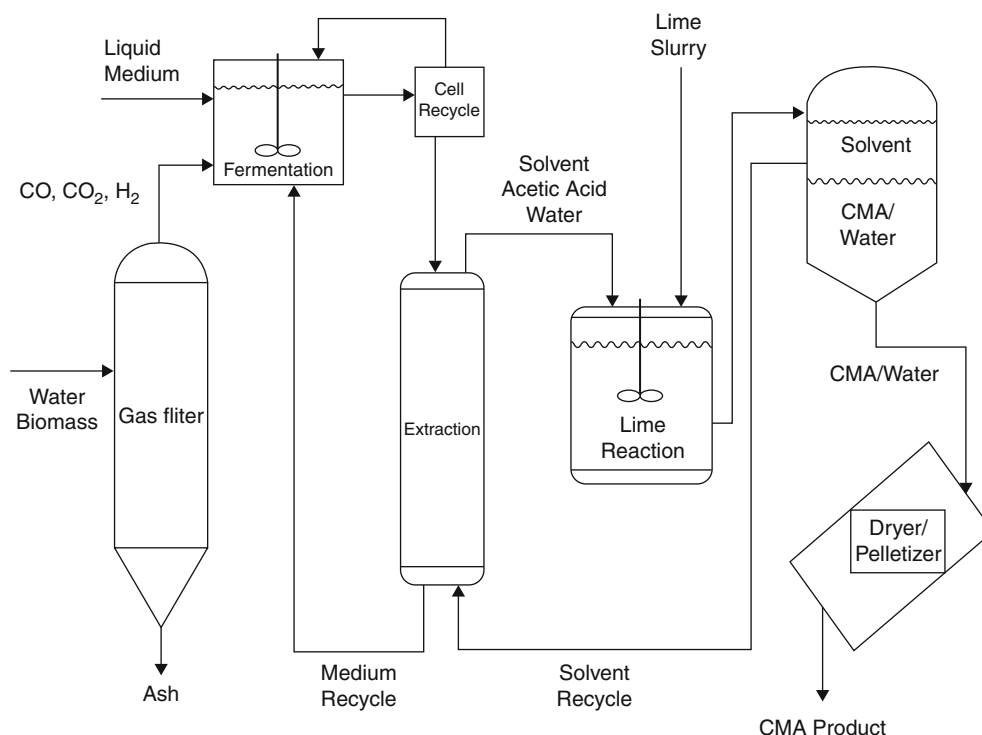

■ Fig. 1.7

Process for production of calcium magnesium acetate (CMA) from municipal solid wastes (MSW), sludge, or other biomass. Following gasification of the waste, the synthesis gas (CO , CO_2 , and H_2) is cooled and fed to a continuously stirred-tank reactor containing a liquid stream with nutrient salts and vitamins. The gases are fermented by an anaerobic acetogenic bacterial culture to form acetic acid. A cell separation system is used to recycle cells back to the reactor, maintaining a high cell concentration and a high production rate and yield of acetic acid. The product stream (15–20 g) acetic acid is fed to an extraction column for solvent extraction of acetic acid yielding 50 g/l. In a stirred reaction tank, Mg lime is added to form CMA. The CMA water stream is fed to a dryer/pelletizer (From Basu et al. (1999), with permission)

Whey, a by-product from the manufacture of cheese and casein, contains about 4.5 % lactose, 1 % protein, and some salts and lactic acid. The cheese industry in the United States produces more than 57 billion pounds/year of liquid whey with only one-half used in human food and animal feed. Disposal of the excess cheese whey remains an important problem for the dairy industry. A novel fibrous bed bioreactor has been developed for fermentation of whey lactose to produce acetic acid by a coculture of immobilized cells of *Lactobacillus lactis* and *Clostridium formicoaceticum* (Huang and yang 1998). The coculture consists of a homolactic bacterium and a homoacetic bacterium. These two bacteria sequentially convert lactose to lactate and then lactate to acetate, with an acetate yield from lactose greater than 90 %. The performance of *C. formicoaceticum* in the fibrous bed bioreactor was excellent owing to the high cell density (30 g/l) maintained. In fed-batch operation with corn steep liquor as nutrient at 37 °C and pH 7.6, the productivity was about 0.2 g/l-h, and the acetate output was 70 g/l. Thus, the *C. formicoaceticum* in this bioreactor became tolerant to high acetic acid concentration compared to free cells. The comobilization with the homolactic bacterium,

L. lactis, in the fibrous bed removed the requirement for purging O_2 from the whey medium to allow growth of the strictly anaerobic *C. formicoaceticum*. *Lactococcus lactis* is not as sensitive to O_2 and removes the residual O_2 from the medium.

Two processes for production of 24 t/day of CMA from 10⁶ lbs of cheese whey permeate per day utilizing the fibrous bed bioreactors were evaluated for product quality and manufacturing costs (Yang et al. 1999). ● Figure 1.8 diagrams both processes.

In Process 1, the whey is subjected to two tandem fermentations yielding acetic acid, which is then partially extracted from the beer before mixing with dolime to obtain CMA; in Process 2, the whey is fermented by coculture with CaO/MgO added to adjust the pH of the beer. The beer is then evaporated and dried. The CMA produced by both processes had properties very similar to commercial CMA prepared from glacial acetic acid, with a product cost for Process 2 of \$291/t and for Process 1 of \$328/t. The market price for commercial CMA is about \$1,000/t, which is due to the present market price of about \$700/t of synthetic glacial acetic acid (Yang et al. 1999).

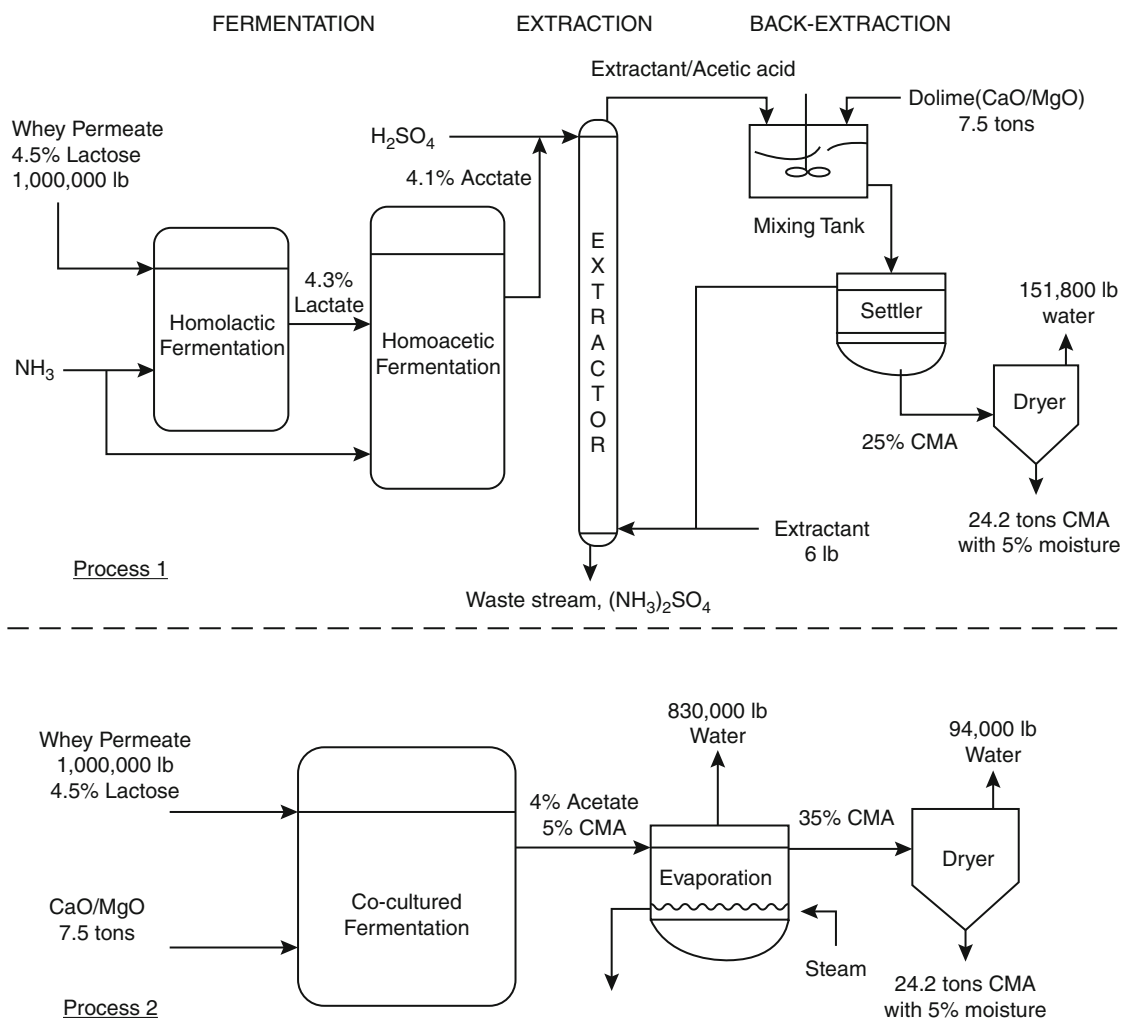

Fig. 1.8

Two processes for production of calcium magnesium acetate (CMA) from cheese whey permeate. In Process 1, the homolactic fermentation of whey lactose by *Lactococcus lactis* and the homoacetic fermentation of lactic acid by *Clostridium formicoaceticum* are carried out in tandem to produce 4.1 % acetate. Acetic acid is concentrated using solvent extraction. Dolime (CaO/MgO) is added to the extractant acetic acid mixture in a mixing tank. Extractant is recovered. CMA water is fed to a dryer/pelletizer. In Process 2, the whey lactose is converted to acetic acid by a simultaneously fermenting coculture of *L. lactis* and *C. formicoaceticum*. Because CaO/MgO is added during the fermentation, the product is 5 % CMA (4 % acetate). The entire culture beer is steam evaporated to a 35 % CMA water mixture, which is fed to a dryer/pelletizer (From Yang et al. (1999), with permission)

Prospects for Bacterial Acetic Acid Production

Specialized Product Areas

For the immediate future, chemical synthesis of acetic acid as a commodity chemical from petrochemicals is the major method for production throughout the world. Figure 1.5 diagrams the major chemical intermediates (precursors of the major industrial products) formed from acetic acid. Production of vinyl acetate, chloroacetic acid, acetic anhydride, and acetate esters requires glacial acetic acid, which is most inexpensively produced by the carbonylation of methanol, the Monsanto process, or by catalytic oxidation

of butane (Agreda and Zoeller 1993). More than 95 % of all acetic acid production is directed toward these four precursors.

Is there a niche in which the bacterial processes can be focused on for profitability in the immediate future? First of all, the vinegar industry employing *Acetobacter* species as biocatalysts will certainly continue as a viable presence in the future. Production of vinegar from an expanding variety of fruits and grain sources will always maintain a strong market position in the food industry. The Frings Acetator-based process, utilizing dilute alcohol mashes, remains the most efficient and profitable production method in the food and canning industry (Ebner et al. 1996).

Secondly, the developed bacteria-catalyzed production of inexpensive calcium magnesium acetate (CMA) and potassium acetate (KA) from gasified municipal solid wastes (MSW) or from waste cheese whey is an important product area (see section ➊ “Development of Processes for Production of Calcium Magnesium Acetate” in this chapter). The superiority of CMA and KA as deicers for roads and airport runways as well as the economic advantage of the bacteria-based production processes predicts an important area for profitable industrial development for the future. It has been estimated that if only 10 % of rock salt is replaced with CMA, the projected annual use of CMA deicer would be $2\text{--}2.8 \times 10^9$ lbs/year. There are also a number of other important industrial uses for acetate salts listed in ➋ Fig. 1.5, such as for heat transfer liquids, meat preservation, and fungicides.

Acetic Acid Production from Bacteria-Based Processes

A major decrease in the capacity to synthesize industrial acetic acid from methanol and CO or by other chemical processes may occur at the end of the next century due to depletion of natural gas and petroleum resources together with an increasing demand for these materials worldwide. With price increases accompanying this situation, bacteria-based processes can certainly become major players in the glacial acetic acid market.

Which bacterial process is most attractive for acetic acid production within this future scenario? Ethanol oxidation to acetic acid by the *Acetobacter* process has major advantages over the sugar fermentations to acetic acid by the various acetogens such as *Clostridium thermoaceticum*. Comparing ➌ Tables 1.5 and ➌ 1.6 (see section ➌ “Current Research and Development”), the former process yields higher output (g/l) and higher productivity (g/l-h). In addition, industrial production of glacial acetic acid has been carried out using the *Acetobacter* process (Ebner and Follmann 1983). Along with the future depletion of petroleum reserves, industrial ethanol production would certainly increase, providing a major source of fuel as well as commodity chemicals. The capacity for fuel ethanol production in the United States as of 1991 was 19×10^9 lbs/year (Kosaric 1996). Acetic acid production plants using the Frings Acetator® and new extraction technologies could produce industrial glacial acetic acid directly from the ethanol streams of future ethanol production plants.

A second prospect for acetic acid production is the direct conversion of gasification products, CO, CO₂, and H₂, to acetic acid by anaerobic acetogens. ➍ Table 1.3 (see section ➍ “Commercial Applications” in this chapter) is a list of acetogenic bacteria that utilize these gases in addition to methanol, producing almost exclusively acetic acid. The demonstration of acetic acid production from gasified MSW and other carbon sources by the acetogen ER12 showed that these waste sources can be utilized to produce acetate salts efficiently and profitably (see section ➍ “Development of Processes for Production of Calcium Magnesium Acetate” in this chapter). Production of

glacial acetic acid on a large scale would require development of additional extraction and distillation technologies to separate acetate from the dilute beers. Research efforts focused on increasing acid tolerance of the anaerobic acetogenic production strains by mutation or by immobilization methods will be important to the success of these processes. A future goal will be to develop acetogens that utilize waste sugar sources and/or degrade cellulosic polymers while producing a high proportion of acetic acid (>90 %) in the product steam.

Lactic Acid

Introduction

With the development of agriculture, at about 4–5,000 BCE, the problem of food storage for future use emerged. It was recognized early that fermentation of foods such as milk, vegetables, fruits, and meats resulted in both enhanced flavors and better preservation. Food containers dating from 2300 BCE discovered in Egypt with cheese-like residues suggest that lactic acid fermentations have been used for at least 4 to 5,000 years (McGee 1984). The manufacturing processes applied in these ancient “lactic acid” fermentations were household or small scale and craft centered, so improvements were small and slow. But the development of a true technology of the fermentation process had to await the Industrial Revolution in the eighteenth century, bringing with it the advent of the science of chemistry. Lactic acid (2-hydroxypropionic acid), the major acid in these fermentations, was first identified as a chemical substance in sour milk whey by Carl Wilhelm Scheele in 1780. Scheele was a gifted experimentalist and probably the first organic chemist in history (Benninga 1990). Besides lactic acid, he also discovered tartaric acid, citric acid, malic acid, and a number of other organic acids.

In 1857, Louis Pasteur was the first to recognize that a lactic fermentation was due to a peculiar gray substance he called a “lactic yeast,” which he found was responsible for production of lactic acid. Further, he showed that the lactic yeast was distinctly different from the brewer’s yeast that converted sugars to alcohol and CO₂. Later, in 1877, the careful experiments of the famous surgeon, Joseph Lister, demonstrated that only a single bacterium, *Bacterium lactis*, was sufficient to bring about souring or fermentation of cows’ milk. Lister’s landmark experiments established not only that one bacterium would cause the lactic acid fermentation but also that his dilution method made it possible to prepare pure cultures of a single bacterial type. Following Lister’s discovery, isolation of pure cultures of lactic acid bacteria became a vital stage in developing a scientific approach to any microbial fermentation process.

The early development of microbial processes for industrial production of ethanol or lactic acid occurred in Berlin at the “Research Institute for Fermentation Industries,” directed by Max Delbrück. The major accomplishments of this institution were the preparation of pure cultures of bacteria or yeasts for industrial fermentations and the application of the principle of “natural pure culturing.” In “natural pure culturing,” the

characteristic properties of the desired microbe are used (in an industrial process) to suppress the growth of undesirable bacteria, thereby allowing its growth to dominate. This principle was applied to lactic acid production by raising the fermenter temperature to 45–50 °C, which permitted growth of the lactic acid bacteria while preventing growth of most contaminant microorganisms.

The first industrial fermentation for lactic acid production was at the Avery Lactate Co. in Littleton, Massachusetts. Charles Avery, a chemist who attended Massachusetts Institute of Technology (MIT), discovered that (to produce baking powder) calcium lactate would act as an acidulant in place of the more expensive cream of tartar (potassium bitartrate) when added to sodium bicarbonate. At that time, baking powder had been introduced into the baking industry. However, the new product was a commercial failure owing to both technical problems and economic competition from another effective acidulant, exsiccated alum (Benninga 1990). Pure cultures of *Lactobacillus delbrueckii* and *Lactobacillus bulgaricus* were prepared for industrial use by Max Delbrück's Institute for the Fermentation Industries in Berlin from about 1896. Taking advantage of these pure cultures, Albert Boehringer established the first commercially successful large-scale lactic acid production plant in Ingelheim. It came on line in the late 1890s, producing technical grade lactic acid (50 % and 80 %), which was sold for use in the textile and leather industries, replacing tartaric acid and tartrates. Prior to 1914, five lactic acid production plants emerged in the United States. However, imported German technical grade lactic acid was of the higher quality required for textile, leather, and pharmaceutical uses, and thus it competed successfully in the US market. During World War I, the lactic acid industry in the United States expanded rapidly to a total production of 4.6×10^6 lbs/year by 1919, as a result of the disappearance of German competition. However, during the 1920s, the lactic acid fermentation industry in Germany (e.g., Boehringer and E. Merck) recovered, and their prewar export markets were rapidly reestablished. Because of the high quality and low prices resulting from new scientific and

technical advances and production efficiency, the German exports of lactic acid almost wiped out production in the United States. This lactic acid production (along with worldwide production) again increased, growing to a peak of $7.2\text{--}9.0 \times 10^6$ lbs/year during World War II. During this war, sodium and potassium lactate were used as a coolant for armored vehicles in place of glycerol. Between World War II and 1963, lactic acid production in the United States leveled off at about 4.6×10^6 lbs/year.

In 1963, synthetic lactic acid production began on a commercial scale. The chemical synthesis route for synthetic lactic acid yields a racemic mixture of DL-isomers. The commercial process is based on lactonitrile (Holten et al. 1971). Lactonitrile is produced by the base-catalyzed addition of hydrogen cyanide to acetaldehyde. Lactonitrile is then hydrolyzed by strong acid to yield lactic acid, which is purified and recovered. Today, synthetic lactic acid is produced mostly in the United States and Japan, and it accounts for about 50 % of total worldwide production. Industrial fermentations also yield about half the world's lactic acid production and thus are very competitive.

Scientific Background

The physical and chemical properties of lactic acid are extensively covered by Holten et al. (1971). Some of these properties are listed in [Table 1.7](#).

The two optically active enantiomeric forms are L(+) dextrorotary and D(–) levorotary:

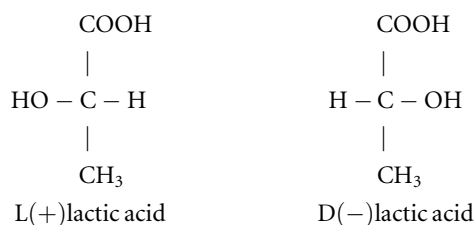

[Table 1.7](#) (from Litchfield 1996) shows that the zinc salts of the two enantiomers have the reverse optical activity of the free

Table 1.7
Selected properties of lactic acid enantiomers

Property	Enantiomer and chemical abstracts service registry no.		
	L(+) 79-35-4	D(–) 10326-41-7	DL 598-82-3
Molecular weight	90.08	90.08	90.08
Melting point (°C)	52.8–53.6	52.8–53.6	16.8–33
Boiling point (°C)		103	82–85
Optical rotation $[\alpha]_D^{20}$, in degrees:			
Acid	+2.5	–2.5	
Zinc salt	–8.2	+8.18	
Dissociation constant	1.90×10^{-4}		1.38×10^{-4}
pK (25 °C)	3.79	3.83	3.73

From Litchfield (1996), with permission

acid. Esters of the two isomers also show the same optical activity shift. Vick Roy (1985) citing Lockwood et al. (1965) states that although the L(+) form appears to be dextrorotatory, it may actually be levorotary as are the salts and esters. The apparent (+) optical rotation may be due to formation of an ethylene oxide bridge between carbons 1 and 2, with a tautomeric shift of the hydroxyl group from carbon 1 to the carbonyl group. Salts and acids cannot form the epoxide ring and are levorotary. Lactic acid is infinitely soluble in water and has low volatility. In solutions of 20 % or more, lactic acid polymerizes into linear dimers of lactoyl lactate or higher polymers as well as cyclic dimers of D, D-, L, L-, or D, L-lactides. Lactic acid is both an organic acid and alcohol and therefore can participate in many chemical reactions. The lactic acid bacteria used in industrial fermentations or under development for commercialization are listed in Table 1.8. The various bacterial strains produce either almost pure lactic acid enantiomers, L(+) or D(-), or a racemic mixture of DL-lactic acid. The present nomenclature (Kandler and Weiss 1986) lists *Lactobacillus delbrueckii* subsp. *bulgaricus* and *Lactobacillus rhamnosus* (formally *Lactobacillus delbrueckii*) as producers of D(-) and L(+) lactic acid, respectively (see Table 1.8). In earlier industrial fermentations producing L(+) lactic acid, *L. delbrueckii* was the specified species used. Thus, it is important to be aware of improper identification of strains in the literature, owing to frequent reclassifications. Because of the new markets for specialty polylactic acid polymers, there is a need for L, L-, D, L- and D, D-lactide dimers as precursors of polymers with different physical properties (Datta et al. 1995). Strain selection for commercial-scale fermentation focuses on (1) rapid fermentation of inexpensive carbon sources with low nitrogen content, (2) high yield of stereospecific lactic acid with low amounts of cell mass and other products, and (3) tolerance to low pH (below pH 5) and high temperature (about 45 °C). The industrially important organisms are “facultative anaerobes” in that they

tolerate oxygen but do not use it as a final electron acceptor in respiration to generate a proton gradient for ATP synthesis. In addition, the fermentation process characterized by high temperature (above 40 °C), low oxygen, high lactic acid, and low pH tends to restrict contamination by unwanted bacteria.

Lactobacillus rhamnosus (formerly *L. delbrueckii*) produces high yields of L(+)-lactic acid from sucrose and glucose at 45 °C, making it an excellent commercial production strain (Table 1.8). But this bacterium will not utilize lactose, so it cannot make use of cheese whey. *Lactobacillus delbrueckii* subsp. *bulgaricus* and *L. helveticus* both ferment lactose from cheese whey, producing high yields of lactic acid. *Lactobacillus delbrueckii* produces the D(-) enantiomer and *L. helveticus* a racemic mixture of DL-lactic acid. Because most commercial fermentations are developed for L(+)-lactic acid production, strains of *L. casei* and *Lactococcus lactis* are being developed for fermentation of lactose sources such as cheese whey.

There are two pathways for the uptake and metabolism of lactose by the lactose-fermenting lactic acid bacteria summarized in Fig. 1.9 (Davidson et al. 1995). One pathway transports lactose into the cell using a proton symporter, which is a classical lactose permease. Hydrolysis of lactose is catalyzed by a β -galactosidase to D-glucose and D-galactose. D-galactose is converted to glucose-1-phosphate by the Leloir pathway (Gottschalk 1986), and both glucose and glucose-6-phosphate are further metabolized by the Embden-Meyerhof pathway to lactic acid. The second pathway uses a phosphoenolpyruvate-dependent phosphotransferase system (PEP: PTS, Lac specific) to form lactose-6-phosphate from lactose as it is transported through the cytoplasmic membrane. The lactose-6 phosphate is hydrolyzed by phosphoryl- β -galactosidase to glucose and galactose-6-phosphate. The galactose-6-phosphate is converted to tagatose-6-phosphate, then tagatose-1, 6-biphosphate, and finally triose-phosphates by a series of enzymes. The triose-phosphates and glucose then enter the Embden-Meyerhof

Table 1.8

Selected lactic acid bacteria: their fermentation pathways, lactic acid enantiomer produced, and major carbon sources used

Bacteria	Fermentation pathway	Lactic acid enantiomer	Carbon sources substrates and complex
<i>Lactobacillus delbrueckii</i> subsp. <i>bulgaricus</i> (formerly <i>L. bulgaricus</i>)	Obligate homolactic	D(-)	Lactose, cheese whey, casein whey, and cheese whey permeate
<i>Lactobacillus rhamnosus</i> (formerly <i>L. delbrueckii</i>)	Homolactic inducible heterolactic	L(+)	Glucose, sucrose, and potatoes
<i>Lactobacillus helveticus</i>	Obligate homolactic	D, L	Cheese whey permeate and lactose
<i>Lactobacillus amylophilus</i>	Obligate homolactic	L(+)	Starch
<i>Lactobacillus amylovorus</i>	Obligate homolactic	D, L	Starch
<i>Lactobacillus casei</i> subsp. <i>casei</i> and subsp. <i>rhamnosus</i>	Homolactic inducible heterolactic	L(+)	Lactose and cheese whey
<i>Lactococcus lactis</i> subsp. <i>lactis</i> and subsp. <i>cremoris</i> (formerly <i>Streptococcus lactis</i>)	Obligate homolactic	L(+)	Lactose and cheese whey permeate
<i>Streptococcus thermophilus</i>	Obligate homolactic	L(+)	Lactose

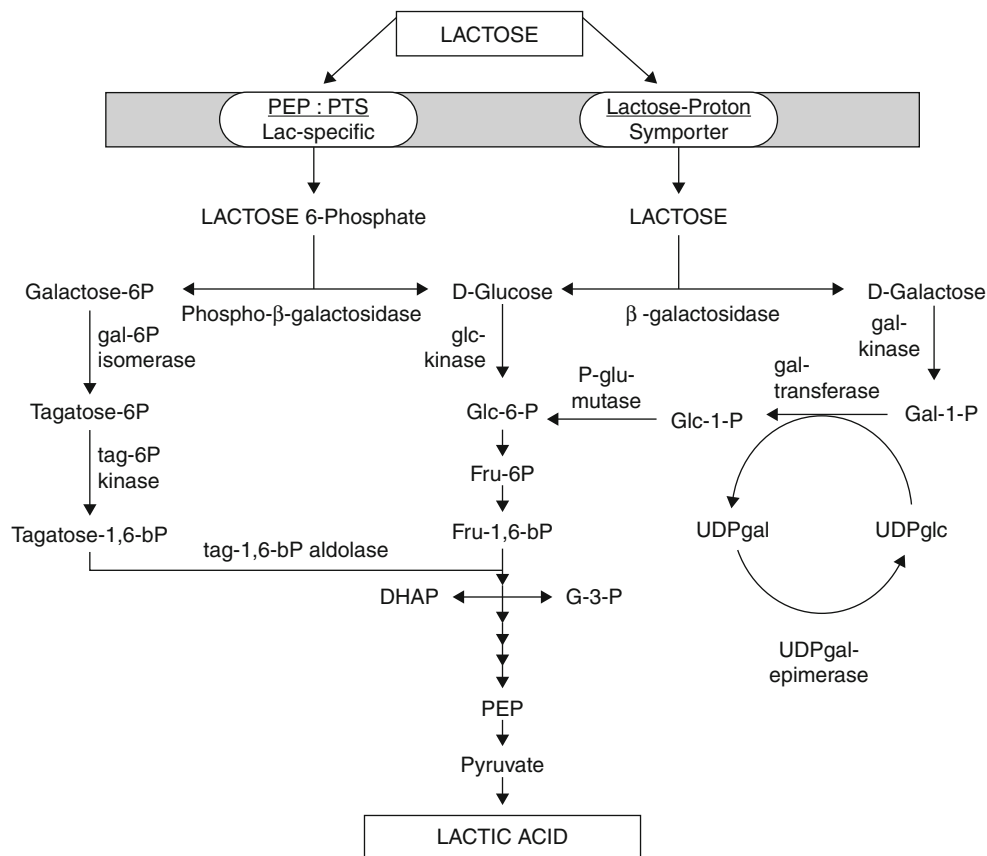

Fig. 1.9
Pathways for uptake of lactose and metabolism to lactic acid

pathway as shown in Fig. 1.9. *Lactobacillus delbrueckii* and *L. helveticus* contain the lactose-permease- β -galactosidase pathway, whereas *L. casei* and the *Lactococcus lactis* have only the PEP:PTS and phospho- β -galactosidase pathway (Arihara and Luchansky 1995).

Two species of *Lactobacillus* that utilize starch as a substrate are listed in Table 1.8. Although starch is not normally utilized by lactic acid bacteria, two species, *L. amylophilus* (Mercier et al. 1992) and *L. amylovorus* (Cheng et al. 1991; Zhang and Cheryan 1994), have been isolated and are able to produce a high yield of lactic acid from liquefied starch in experimental fermenters.

The industrial strains of lactic acid bacteria can completely ferment a medium of 12–15 % sugar in 2–4 days with greater than a 90 % yield of lactic acid. All of these bacteria are considered homofermentative in that they utilize a homolactic fermentation pathway, producing two molecules of lactic acid for each molecule of hexose. As diagrammed in Fig. 1.10, the Embden-Meyerhof pathway is used in the homolactic fermentation.

The fructose 1,6-diphosphate (FDP) is the key intermediate, and the two enzymes, fructose-6-phosphate kinase and FDP aldolase, are diagnostic for this pathway. In some lactic

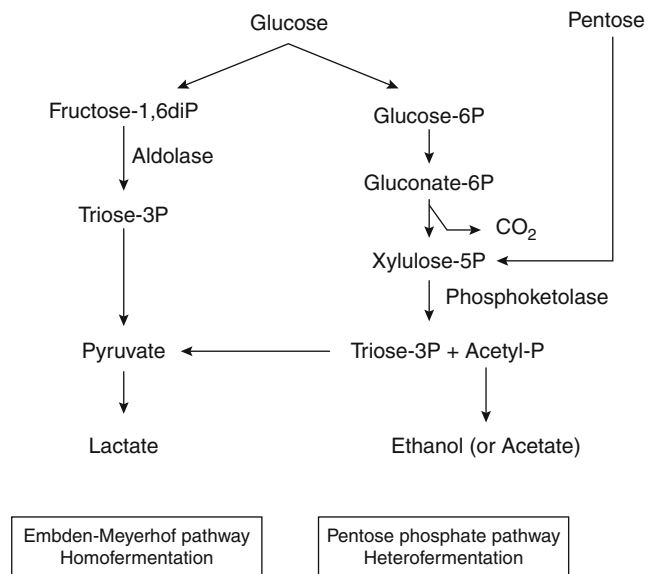

Fig. 1.10
Metabolic pathways of carbohydrates used by lactobacilli (From Bigelis and Tsai (1995), with permission)

acid bacteria, the L-lactic dehydrogenase (LDH) is allosterically activated by FDP and/or Mn^{++} ion. The obligate homolactic strains listed in Table 1.8 ferment sugars (usually hexoses) only by this pathway. Table 1.8 also lists two homolactic-inducible heterolactic strains, *L. rhamnosus* and *L. casei*. These lactic acid bacteria can use the pentose phosphate pathway shown in Fig. 1.10 by inducing the enzyme phosphoketolase. All of the other enzymes needed for this pathway are present in all these bacteria. Induction of this pathway usually requires very low hexose concentrations (and thus lower internal FDP) and/or added pentose. This pathway produces 1 mole each of lactate, acetate (or ethanol), and CO_2 for each mole of hexose, or 1 mole each of lactate and acetate for each mole of pentose. A few lactic acid bacteria use exclusively the pentose phosphate pathway because they do not produce the enzyme FDP aldolase. However, these strains are not useful in commercial lactic acid production. The production of a stereospecific product, D(-)- or L(+)-lactic acid, by these bacteria is due to the stereospecific lactic dehydrogenases, L-LDH and D-LDH. It was thought that bacteria such as *L. plantarum* or *L. helveticus* that produce D, L-lactic acid contained a racemase. However, it was shown that *L. plantarum* contains both enzymes, D-LDH and L-LDH, and thus can easily equilibrate added lactic acid enantiomers by catalysis through pyruvate (Dennis and Kaplan 1960). The two enzymes have quite different properties. Cloning and sequencing of the L-LDH and D-LDH genes revealed no significant homology between them. However, the D-LDH genes from other lactobacilli were found to be homologous (Taguchi and Ohata 1991).

Lactic acid bacteria are well known for their complex nutrient requirements for growth. An array of vitamins, nucleotides, and amino acids or peptides are essential, and the minimum requirements for growth of each strain can vary (Buchta 1983). Further, many of the growth factors significantly increase the rate of lactic acid fermentation. Because of the large number of essential and stimulatory factors, it is impractical to cultivate these organisms in chemically defined medium. In large commercial-scale fermentations, complex nutrient sources such as corn steep liquor, malt extracts, malt sprouts, or soybean extract are added. Although cheap, the crude materials also may contain specific inhibitors of the fermentation and also increase the cost of lactic acid purification downstream (Bigelis and Tsai 1995). Thus, a balance must be established between the high rate and yield of a fermentation and the purification costs. Because carbon dioxide (CO_2) fixation is required for many biosynthetic pathways in bacteria, it is not surprising that CO_2 is shown to stimulate growth of many lactic acid bacteria. During a pure homolactic fermentation of sugars, no CO_2 is produced. To prevent a CO_2 limitation, calcium carbonate may be added to neutralize lactic acid for pH control during a fermentation (Bigelis and Tsai 1995). Some lactic acid bacteria require added fatty acids or fatty acid esters (Tweens). Often, fatty acids can be synthesized by these organisms when the vitamin biotin is added to the fermentation broth (Bigelis and Tsai 1995).

The different lactic acid bacterial strains show pronounced differences in proteolytic capacities allowing them to grow on

protein sources from meats, vegetables, and milks for a supply of amino acids and small peptides. Because these bacteria have multiple amino acid requirements and cannot utilize ammonia as a sole nitrogen source, their growth is dependent upon an efficient system for protein and peptide degradation and transport. The lactic acid bacterial strains selected for a specific industrial fermentation (e.g., sucrose with added corn steep liquor) must have optimal proteolytic characteristics as well as lactic fermentation abilities for the particular set of raw materials used. The efficiency of the fermentation is intimately dependent on the cascade of proteolytic reactions that occur during growth and fermentation. The genetics and physiology of the proteolytic system of lactic acid bacteria have been reviewed (Kok and deVos 1994). Peptides are sometimes more effective than free amino acids for growth and fermentation. For example, whey protein with an average peptide length of six amino acids (700 kDa) was found most effective for high production rates of lactic acid in *L. delbrueckii* subsp. *bulgaricus* (Leh and Charles 1989).

Microbial production of lactic acid is vulnerable to bacteriophage attack. Industrial fermentations as well as food and dairy fermentation using *Lactobacillus* spp., *Lactococcus* spp., and *Streptococcus* spp. are subject to disruption by bacteriophage infection. Because of the size of this problem and its economic impact, much research has been carried out over the past six decades on the biology of the bacteriophages and the resistance mechanisms mounted by these bacteria to prevent phage infection. Klaenhammer and Fitzgerald (1994) have reviewed and evaluated this research. They point to factors that contribute to the onset of bacteriophage infection in the fermentation process, such as reliance on specialized strains and increasing pressure of manufacturing schedules. The classification of the known lactic acid bacteriophages, how they adsorb to cells, and phage lysogeny and lytic development are fairly well known. The genetics and biochemistry of bacteriophage resistance of lactic acid bacteria suggest some practical applications (Klaenhammer and Fitzgerald 1994).

The major mechanisms of phage resistance which have been identified in the lactic acid bacteria include blocking of virus adsorption, restriction endonucleases and modification methylases, and abortive infection systems. Over the past 10 years, genetic studies of *Lactococcus* sp. show that these bacteria often carry the genes for these resistance devices on a variety of plasmids. The other lactic acid bacteria have also been shown to carry plasmid-borne resistance mechanisms as well. In their review, Klaenhammer and Fitzgerald (1994) outline "genetic addition strategies" for using these plasmids (carrying restriction systems for transfer and "stacking" into commercial strains) to improve bacterial resistance to multiple phage attack. Advances in the molecular biology of *L. lactis* and its phages have encouraged the emergence of novel recombinant phage defense systems which complement the mechanisms described above. For example, a suicide system has been developed that consists of a cassette with a promoter from a lytic phage (031) linked to a lethal gene (the *LlaI* restriction site; Djordjevic et al. 1997). When the cassette is inserted in the *L. lactis*

chromosome, the phage-specific inducible promoter is activated by phage 031 infection, causing expression of the linked lethal gene, which results in death of the host cell and degradation of the phage genome.

Another example of a phage defense system employs antisense mRNA technology as a barrier to phage expression. Production of a specific antisense mRNA may act by competing with normal mRNA at the initiation of translation on the surface of the ribosome. Secondly, the direct binding of antisense RNA to the normal RNA may make it susceptible to degradation by double-stranded RNases in the cell. Walker and Klaenhammer (2000) produced antisense constructs of “late genes” of phage 031 with *ori31* as a promoter, which were inserted into recombinant plasmids. When *L. lactis* carrying these plasmids are infected with bacteriophage 031, they produce large amounts of late 031 antisense mRNA. This results in significant protection of *L. lactis* against 031 infection. Clearly, in any large-scale commercial fermentation, a carefully planned, long-range phage defense program must be in place.

Commercial Applications

Fermentation

For commercial-scale production of lactic acid by fermentation, there are choices of feedstock, fermentation methods, product recovery, and final uses and applications that must be addressed. The feedstock carbohydrate to be fermented as well as the enantiomeric form of lactic acid desired (D–, L+, or DL) will determine the organism selected to catalyze the process (see section • “Scientific Background” and • Table 1.8). The choice of feedstock should be optimized considering (1) low cost, (2) low levels of contaminants, (3) fast fermentation rate, (4) high lactic acid yield, (5) little or no by-product formation, (6) little or no pretreatment required, and (7) year-round availability (Vick Roy 1985). Long-distance transport of feedstocks to the fermentation plant can be costly and should be avoided. Litchfield (1996) stresses that ideally a fermentation of cheese whey to lactic acid should be located close to cheese-manufacturing plants because cheese whey is very dilute (4–4.5 % lactose) and easily infected with bacteria. Also, refrigeration during storage or transport allows lactose to crystallize out of the whey owing to its low water solubility. Yet, cheese whey and cheese whey permeate are low-cost available feedstocks. In 1994, in the United States, about 57×10^6 lbs (25.9×10^9 kg) of liquid whey (4–4.5 % lactose) was a by-product from dairy product manufacture. Only one-half is converted commercially to dried products such as lactose. The rest is waste and has been used in large-scale commercial fermentations for lactic acid by companies such as Sheffield Bio-Science, Inc., Norwich, NY. Complex carbohydrates containing starch or sugar can be used as feedstocks. In early fermentations, beet molasses was used, but a high-quality lactic acid was produced only after an added step of solvent extraction during product recovery (Buchta 1983). Thus, crude

feedstocks should be avoided because added chemical contaminants are often difficult to remove during the downstream recovery stage. Purified sucrose from sugar beets and sugarcane, glucose from hydrolyzed starch sources such as corn, and wheys containing lactose are the major raw materials used today. The use of purified feedstocks in the fermentation ensures lower cost of the final product recovery. In the United States, glucose from enzyme-hydrolyzed cornstarch produced in wet milling is the major substrate for commercial lactic acid formation. Direct fermentations of liquid cornstarch by the amylolytic *Lactobacillus* strains, such as *L. amylophilus* (Mercier et al. 1992) and *L. amylovorus* (Cheng et al. 1991), have been carried out in the laboratory; however, no commercial processes are presently in use. The availability of purified sucrose as a feedstock from beets in Europe and from sugarcane in Brazil permits commercial production of high-quality lactic acid in these regions. Nevertheless, sugar prices vary considerably and, thus, the economics of lactic acid production may be strongly affected.

The major fermentation method used to produce lactic acid on an industrial scale is the batch fermentation process. The factors affecting the batch process have been reviewed (Litchfield 1996; Vick Roy 1985). Because of the very corrosive properties of lactic acid, construction materials used for the fermenter and downstream processing equipment are a major cost item. Copper, copper alloys, steel, chrome steel, and high-nickel steels are all unsatisfactory. High-molybdenum stainless steel like SS316 is satisfactory. Plastic linings of fermentation tanks have been used successfully, and new developments in ceramics and plastics may provide future choices (Vick Roy 1985).

Contamination with other bacteria is not a big problem in commercial fermentation if fermenters are steam treated or chemically sterilized prior to filling with a heated medium. A pure-culture inoculum is usually used, and the fermentation is run at a high temperature (43–50 °C) and with very low oxygen. Eventually, a high concentration of lactic acid accumulates. All of these conditions tend to inhibit growth of many potential contaminants. Specific conditions vary with the industrial process. For example, during the fermentation of 15 % glucose by *L. rhamnosus* in 30,000-gal reactors, a temperature of 45–60 °C and a pH of 5.0–6.0 were maintained for 4–6 days, producing an 80–90 % yield of lactic acid (Inskeep et al. 1952). For fermentation of cheese whey (4–5 % lactose) by *L. delbrueckii* subsp. *bulgaricus* in a 5,000-gal reactor, 43 °C and a pH of 5.5 were maintained for 1–2 days with a yield of 85–90 % lactic acid (Campbell 1953). A flow chart of the Purac fermentation process for lactic acid production is diagrammed in • Fig. 1.11. However, companies in the United States starting lactic acid production by fermentation use newly developed proprietary processes (Datta et al. 1995).

Calcium carbonate is usually added during the batch fermentation to control the pH, and the highest concentration of lactic acid (12–15 %) is limited by the precipitation of calcium lactate from the broth. Temperature control is maintained with heat transfer coils using circulating water, and the cells are retained in a mixed suspension by mechanical agitators or

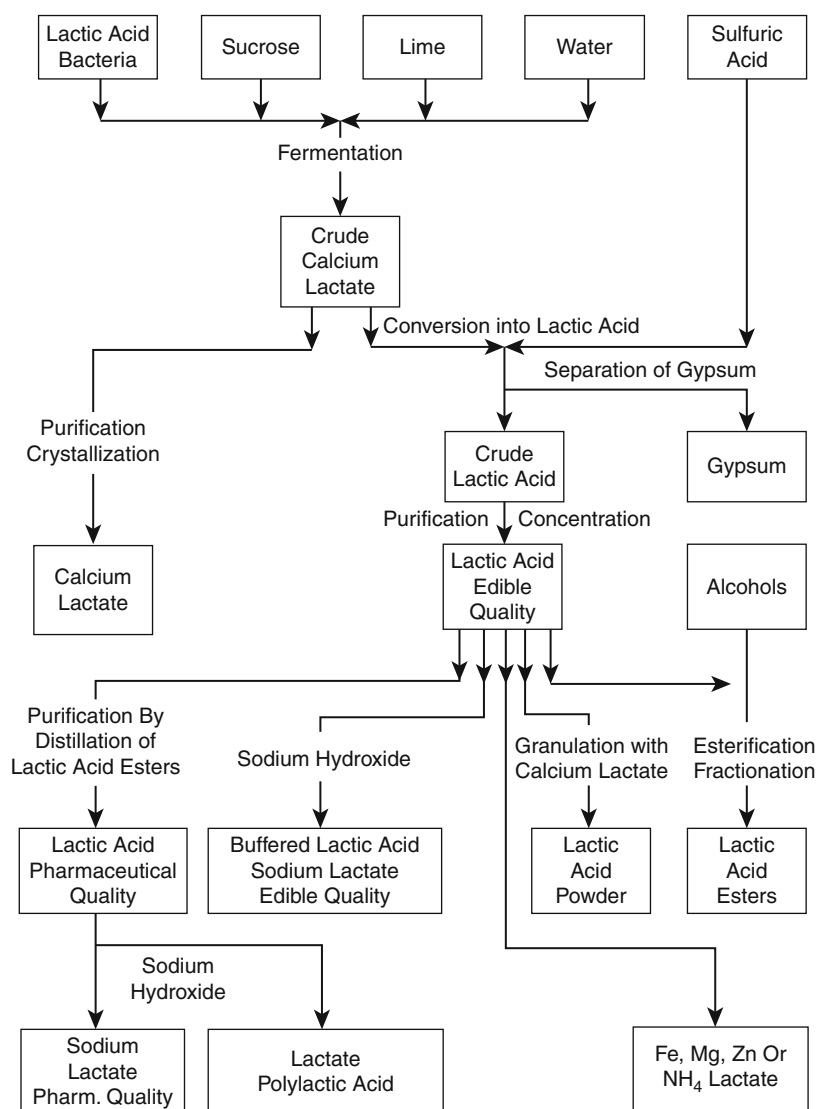

■ Fig. 1.11

Flowchart for production of lactic acid and its derivatives by the Purac fermentation process (From Bigelis and Tsai (1995), with permission)

pump circulation. The productivity of large batch commercial reactors is low, at 1–3 g/l·h. The final biomass of cells is lower than 30 wt.% and usually about 15 wt.% of the amount of sugar added initially. The fermentation rate is initially high but then slows down as nitrogenous sources are depleted and lactic acid accumulates. Litchfield (1996) has reviewed work that shows a significant effect of inoculum size on lactic acid yields obtained with *L. delbrueckii* subsp. *bulgaricus*, *L. casei*, and *L. helveticus* in laboratory-scale fermentation. However, little is reported on the effect of inoculum sizes for commercial-scale lactic acid fermentation.

Product Recovery

The recovery of lactic acid from the fermentation medium is a major cost item for the entire process (Vick Roy 1985; Datta

et al. 1995). The product is available in four grades: (1) technical, (2) food (FCC), (3) pharmaceutical (USP), and (4) “heat-stable” lactic acid that will not discolor when heated to 200 °C for a few hours. The greater the purity, the more complex and expensive the recovery process.

The first step in the conventional recovery processes is heating the fermentation beer to 80–100 °C and increasing the pH to 10 to kill the bacteria, coagulate proteins, and maintain calcium lactate’s solubility in the beer. The crude calcium lactate solution is then filtered, decolorized with activated carbon, and concentrated by evaporation. Lactic acid is recovered by addition of sulfuric acid and then further purified by one of the following routes (► Fig. 1.11):

1. Crystallization of calcium lactate (technical)
2. Filtration, carbon treatment, and concentration of lactic acid (food quality)

3. Formation of lactate esters and fractionation (pharmaceutical quality)
4. Distillation of lactic acid esters (highest purity, heat-stable lactic acid)

These purification processes are often combined with liquid-liquid extraction, ion exchange, and adsorption on solid adsorbants. However, for every ton of fermentation lactic acid produced by the conventional recovery process, about 1 t of gypsum ($\text{CaSO}_4 \cdot 2\text{H}_2\text{O}$) by-product is also produced. Ecological and economical disposal thus becomes a problem for a large-scale production facility.

Developments in membrane-based separation and purification of lactic acid have been made. The use of ultrafiltration and electro dialysis provides a new approach for lactic acid recovery that would be low cost and simultaneously avoid the formation of the problem by-product, gypsum (Datta et al. 1995). Advances in membrane technology allowing low-energy desalting electro dialysis have led to a proprietary method for production of fermentation lactic acid from carbohydrates without calcium salt production (Datta 1989). This new technology can be operated as a continuous process and scaled up to large-volume recovery of lactic acid from the fermentation beer and manufacture of lactide polymers (Gruber et al. 1992, 1994). A major commercial effort for lactic acid production and conversion to polylactide by a US agriprocessor, Cargill Dow, incorporates this technology (Datta et al. 1995; Jarvis 2001).

Application and Uses

The major application of lactic acid and lactic compounds is for food additives. Table 1.9 presents a list of applications for lactic acid, lactate salts, and various lactylated fatty acid esters in the food industry.

Lactic acid and the lactate salts are generally recognized as safe by the Food and Drug Administration (FDA) in the United States. The stearyl lactates and other esters used as emulsifiers and bread dough conditioners have also been approved by the FDA. More than 50 % of the lactic acid destined for food uses goes into producing these emulsifying agents for bakery goods. The four most important esters of lactate salts are calcium and sodium stearyl-2-lactylate, glyceryl lactostearate, and glyceryl lactopalmitate (Datta et al. 1995). These products have specific uses in the formulation of cake mixes, dips, and other prepared foods (Table 1.9). Because production of all of these emulsifiers requires the highest-quality “heat-stable” lactic acid, only synthetic lactic acid or heat-stable fermentation lactic acid grades can be used.

Technical grade lactic acid has been used for a long time in the leather-tanning industry as an acidulant. It is used in the finishing of textiles and acid dyeing of wool. Inorganic acids are used competitively in these processes, but lower-cost lactic acid together with environmental regulations against dumping waste salts may favor extensive use of lactic acid in the future.

Table 1.9

Food applications of lactic acids and lactic acid compounds

Compound (Chemical abstracts service registry no.)	Food application	Code of Federal Regulations ^a reference
L(+)-lactic acid (79-35-4) >D(-)- lactic acid (10326-41-7) >DL-lactic acid (598-82-3)	Antimicrobial agent, curing and pickling, flavoring, enhancer, adjuvant pH control, solvent, and vehicle	21 CFR 184.1061
Calcium lactate	Flavoring enhancer, firming agent, leavening agent, nutrient supplement, stabilizer, and thickener	21 CFR 184.1207
Ferrous lactate (5905-52-2)	Nutrient supplements and in infant formula	21 CFR 184.1311
Potassium lactate (996-31-6)	Flavor enhancer, flavoring agent, humectant, and pH control	21 CFR 184.1639
Sodium lactate (72-17-3)	Flavor enhancer, flavoring agent, humectant, pH control, and emulsifier	21 CFR 172.1768
Calcium stearyl-2-lactylate	Dough conditioner in bakery products, whipping agent in egg products, and conditioning agent in dehydrated potatoes	21 CFR 172.844
Sodium stearyl lactylate (25-383-997)	Dough conditioner, emulsifier, processing aid in baked products and in milk or cream substitutes, stabilizer, snack dips, imitation cheeses, and dehydrated potatoes	21 CFR 172.846
Lactylated esters of fatty acids	Emulsifiers, plasticizers, and surface-active agents in foods	21 CFR 172.848
Lactylated fatty acid esters of glycerol and propylene glycol	Emulsifiers, plasticizers, and surface-active agents in foods	21 CFR 172.850
Glycero-lacto esters of fatty acids	Emulsifiers, plasticizers, and surface-active agents in foods	21 CFR 172.852

From Littlefield (1996), with permission

^aCode of federal regulations (1994)

Lactic acid is used in many small-scale applications such as resin production, solder fluxes, lithographic and textile printing, adhesives, electroplating and electropolishing baths, and detergent formulations. These uses may account for 5–10 % of consumption of lactic acid.

There are numerous pharmaceutical and cosmetic applications and formulations containing lactic acid, sodium and calcium lactates, and a range of acyl lactates. Calcium lactate is widely used for treating calcium deficiency. Lactates are added to many cosmetic products as moisturizers, emulsifiers, and stabilizers. Lactates have been promoted in skin care products for improving skin texture and appearance (Smith 1993). Ethyl lactate is an active ingredient in antiacne preparations (Datta et al. 1995).

There are important medical applications for polylactides prepared from the lactide dimer as well as for lactide-glycolide copolymers synthesized from lactide and glycolide dimers. These polymers are used for procedures requiring surgical sutures, implants, bone plates, and controlled drug release, inasmuch as they are biocompatible, biodegradable, and resorbable materials.

Concern over the negative environmental impact of accumulating nondegradable plastic films and containers has been increasing. Replacement of these petroleum-based plastics with biodegradable plastics may be inevitable within the next 50 years. Lactic acid based bioplastics will play an important role in future potential products (see section [“Areas of Research and Development”](#) in this chapter).

Economics

The major commercial producers of lactic acid are listed in [Table 1.10](#). The worldwide market for lactic acid and lactic acid esters was estimated at 60–65,000 t/year (54.5–59 10⁶ kg/year) (Litchfield 1996). Producers of synthetic and fermentation lactic acid are both included, considering they share the market about equally. The United States consumes almost 40 % of annual production (Bigelis and Tsai 1995). The major producer of fermentation lactic acid in the United States is Archer

Daniels Midland Co., with a capacity of 10–20,000 t/year (9.1–18.2 × 10⁶ kg/year; Anonymous 1993). This proprietary fermentation process is presently nonbacterial. In contrast, Sterling Chemicals, a major producer of synthetic lactic acid in the United States, had an annual capacity of 9.5–10,000 t (8.6–9.1 × 10⁶ kg; Bahner 1994). The competitive position of fermentation lactic acid over synthetic lactic acid depends upon the ability to selectively produce desired stereoisomers of lactic acid (D– or L+) instead of a racemic mixture produced by the synthetic route. Use of inexpensive carbohydrate feedstocks and advances in separation technologies keep production costs low.

Example prices in 1994 for both fermentation and synthetic food-grade 50 % and 88 % lactic acid were \$0.71 and \$1.15 per pound (Litchfield 1996).

The technological and thus economic potential of lactic acid and polylactic acid suggest that the market will expand. A large US agriprocessing company, Cargill, has constructed a new fermentation facility with a capacity of 125,000 t/year of lactic acid, incorporating new separation technologies.

Research and Development

Microbial Genetics and Strain Improvement

Mutants of the lactobacilli can be selected following spontaneous or induced mutagenesis. For example, following mutagenesis with ethyl methane sulfonate, three mutants of *L. delbrueckii* ATCC 9649 were selected, which produced a higher yield of lactic acid than the parent strain in a stirred-tank batch fermentation with 12 % glucose. Also, the rate of lactic acid production by the mutant strains was more than twice that of the wild type (Demirci and Pometto 1992). *Escherichia coli*, a mix acid fermenter, was converted by mutation to a homolactic strain. A double mutant strain of *E. coli* RR1 was produced which was deficient in both phosphotransacetylase (mutation in *pta*) and in phosphoenolpyruvate carboxylase (mutation in *ppc*). This strain did not produce significant amounts of acetate or succinate, and thus fermented glucose to primarily D(–) lactic acid (Chang et al. 1999). Certainly, mutagenesis followed by selection for properties such as growth at high temperature or high lactic acid concentration remains a standard method for improvement of production strains.

However, since about 1987, there have been dramatic advances in genetic technology and in understanding genetics of the lactic acid bacteria. Reviews of research and applications of genetic technology to lactic acid production have appeared (Gasson and DeVos 1994; Bigelis and Tsai 1995; Arihara and Luchansky 1995; Davidson et al. 1995; Wang and Lee 1997a). Research predicts that the tools for genetic engineering of lactic acid bacteria provide for an almost unlimited potential for strain development.

Developing a genetic system for lactic acid bacteria was initially dependent upon optimizing a DNA transfer method.

■ Table 1.10

Main producers of lactic acid and lactic acid esters

Synthetic lactic acid: mixture of D and L
Sterling chemicals, Houston, Texas
Musashino Chemical Laboratory Ltd., Isohara, Japan
Fermentation lactic acid: L(+), D(–), or DL
Archer Daniels Midland Co., Decatur, Illinois
Cargill, Minneapolis, Minnesota
Ecological Chemical Co., Conagra/DuPont, Adell, Wisconsin
Chemie Combinatie Amsterdam CCA/PURAC, Gorinchem, the Netherlands

Table 1.11

Escherichia-Lactobacillus shuttle vectors and their applications

Shuttle vectors	Genes expressed	<i>Lactobacillus</i> hosts	Reference
pGKV210	Catalase gene of <i>Lactobacillus sake</i> LTH677	<i>L. casei</i>	Knauf et al. (1992)
pTRK159	Lactacin F gene of <i>Lactobacillus acidophilus</i>	<i>L. acidophilus</i>	Moriana and Klaenhammer (1991)
pLP3537	D-xylose metabolism genes of <i>Lactobacillus pentosus</i>	<i>L. casei</i>	Posno et al. (1991)
pSA3	α -amylase of <i>Bacillus Stearothermophilus</i> and endoglucanase gene of <i>Clostridium thermocellum</i>	<i>L. plantarum</i>	Scheirlinck et al. (1989)

From Bigelis and Tsai (1995), with permission

The most significant advancement was the use of electroporative (high-voltage) transformation first shown in *Lactococcus lactis* (Harlander 1987) and then extended to *Lactobacillus* sp. and other Gram-positive bacteria (Cauvin and Luchansky 1992; Luchansky et al. 1988). Genetic research with *Lactobacillus* utilizes electrotransformation to transfer plasmid vectors for cloning, expression, integration, and transposon mutagenesis. Often, electroporation techniques must be optimized for each bacterial species and new strain under study.

Most plasmid vectors used for cloning, expression, integration, and transposon mutagenesis were initially developed for *Lactococcus lactis* (DeVos and Simons 1994). Shuttle vectors with lactococcal replicons and staphylococcal resistance markers were initially electroporated into strains of lactobacilli with some success. However, consistent high-frequency transformation of lactobacilli has been achieved with several cloning and mutagenesis vectors based on *Lactobacillus* replication regions from cryptic, endogenous plasmids. For example, plasmids pPSC20 and pPSC22 replicated and were stably maintained in *L. lactis*, *Bacillus subtilis*, *E. coli*, and a number of *Lactobacillus* species (Cocconcelli et al. 1991). Table 1.11 lists some *Escherichia-Lactobacillus* shuttle vectors and their applications.

A list of the plasmids of *Lactobacillus* and construction of useful vectors for commercial applications were reviewed (Wang and Lee 1997b).

There is a considerable research effort directed toward stabilizing gene expression in both the lactococci and lactobacilli by integrating desired foreign genes into the bacterial genome. Chromosomal insertion of plasmid-carried genes could prevent segregational instability that may be a problem during large-scale or continuous fermentations. The use of integrative gene cloning and nonreplicative integration vectors with lactococcal strains is reviewed in detail by Gasson and DeVos (1994). Studies demonstrated that integration occurs via homologous single crossover recombination. Using similar nonreplicative vectors in *L. lactis*, it has been shown that chromosomal genes can be insertionally inactivated and that gene replacement recombination is also feasible. The use of insertional vectors for strain stabilization, gene replacement, and gene disruption has been developed for *Lactobacillus* (Arihara and Luchansky 1995).

In *Lactobacillus*, stabilization of cloned genes is usually achieved by chromosomal integration based on homologous recombination with a randomly cloned DNA fragment as the integration target inserted in a nonreplicating plasmid. Using this technique, stable chromosomal integration of α -amylase from *Bacillus stearothermophilus* and a cellulase gene from *Clostridium thermocellum* was achieved in *Lactobacillus plantarum* (Scheirlinck et al. 1989). An integrative “food-grade” cloning vector for *L. acidophilus* was constructed using a piece of chromosomal DNA as an integration target (Lin et al. 1999). A second important technique for generation of stable recombinant lactic acid bacterium strains is the use of a bacteriophage integrase-mediated site-specific insertion into the host chromosome (Auvray et al. 1997; Martin et al. 2000). A third innovation is the development of an integrative vector which allows stable gene insertion specifically into the chromosomal lactose operon of *L. casei* (Gosalbes et al. 2000). The integrated foreign genes followed the same expression pattern as for the lactose genes in that they were repressed by glucose and induced by lactose.

Expression studies are encouraging in that more than 65 *Lactobacillus* genes have been cloned and expressed in *E. coli*. Many *Lactobacillus* genes have been expressed in other lactobacilli, and several heterologous genes have been transferred and expressed in *Lactobacillus* strains (Table 1.11). As lactic acid emerges as a major commodity chemical, research efforts are focusing on direct utilization of inexpensive carbon substrates, such as lactose-containing cheese whey, or starchy and cellulosic biomass sources. Expanding the substrate range of production strains of *Lactobacillus* or building entirely new production strains is now possible by transfer, integration, and expression of the genes for lactose metabolism from *L. casei* combined with other genes essential to catalyze a specific lactic acid production process.

The genes for both of the lactate dehydrogenase enzymes, L-LDH and D-LDH, that control lactic acid stereospecificity in the lactobacilli have been cloned and sequenced. The L-LDH enzyme from a variety of lactic acid bacteria forms a closely related class entirely distinct from the D-LDH enzymes which form a second closely related group of proteins. With broad host-range integration vectors now available, it is possible to

alter the LDHs in lactobacilli by gene replacement or gene disruption. Thus, a production strain of *L. helveticus*, which normally produces a mixture of (D, L)-lactic acid, can be converted to produce exclusively either (D−) or (L+)-lactic acid (Bhowmik and Steele 1994).

Growth of lactic acid bacteria is dependent upon a complex source of organic nitrogen compounds. All of these bacteria are fastidious organisms with multiple amino acid requirements. Thus, rapid growth is dependent upon efficient proteolysis of proteins and transport of amino acids and small peptides. Hydrolysis of proteins may be by protease treatment of the medium prior to fermentation or by the action of proteolytic enzymes produced by the lactobacilli or lactococci during fermentation. In all cases, it is essential that the selected fermentation strain and the protein source be compatible for optimal cell growth and fermentation as well as low accumulation of by-products that will interfere with downstream separation of lactic acid. As a consequence, the proteolytic systems of lactic acid bacteria have been the subject of research efforts over the past 15 years. Most of the detailed biochemistry, cell location of enzymes, and genetic engineering of proteolytic enzymes that have been determined for the lactococci are reviewed by Kok and DeVos (1994). The research on proteolytic systems of *Lactobacillus* strains used in fermentation is more limited but developing rapidly (Arihara and Luchansky 1995).

Overcoming and understanding host-bacteriophage interactions is a major topic of research with the lactic acid bacteria. For example, in *L. helveticus*, a plasmid-linked restriction modification system was identified that blocks fruitful infection by two bacteriophages (Reyes-Gavilan et al. 1990), and in *L. lactis* subsp. *cremoris*, four phage-resistance plasmids have been identified (Forde et al. 1999). Both lytic and lysogenic phages of the lactococci and lactobacilli have been and continue to be under study; genetic strategies for constructing phage-insensitive strains of the lactococci have been formulated (Klaenhammer and Fitzgerald 1994). Walker and Klaenhammer (2000) reported combining two genetic strategies to inhibit infection of *L. lactis* by bacteriophage ϕ 31. The bacteria carrying a low-copy-number plasmid, pTRK360, containing the phage ϕ 31 origin of replication, trigger an explosive production of this plasmid upon phage infection. The large number of plasmid-carried *ori31* genes compete with and inhibit phage ϕ 31 DNA replication, resulting in an efficiency of plaquing of only 0.3. However, these workers combined this strategy with a second strategy employing antisense RNA. To produce a high level of phage ϕ 31 antisense mRNA relative to normal sense mRNA during phage infection, the antisense cassettes containing the late-expressed phage genes (ORF 3 through ORF 6) were subcloned into pTRK360. Infected *L. lactis* carrying this plasmid produced high levels of antisense transcripts later in the lytic cycle. Growth studies at various levels of phage ϕ 31 infection showed that using the dual strategies of competing *ori31* copies and antisense mRNAs of phage ORFs was more effective than using either method alone (Walker and Klaenhammer 2000). The research on the lactococci is being applied to improving phage resistance of *Lactobacillus*, although

presently, little is known about phage-resistant strategies and phage-coded counter defense mechanisms for this group of lactic acid bacteria.

Advances in Fermentation and Separation Technologies

Direct fermentation of starch to lactic acid by lactobacilli is not possible when employing the preferred industrial strains of lactobacilli, considering they use sugars such as glucose or lactose efficiently but do not effectively hydrolyze starch. Although a well-established two-enzyme treatment for starch hydrolysis is applied in the corn wet-milling process to produce glucose, such a process may not be usable for other starchy feedstocks used on a smaller scale. Two approaches to this problem are under development. First, lactic acid production using two starch-hydrolyzing strains, *L. amylophilus* (Mercier et al. 1992) and *L. amylovorus* (Cheng et al. 1991), has been demonstrated. Laboratory-scale results in batch reactors provided conditions for rather good productivity and a greater than 90 % yield of lactic acid. A second approach is an integrated method of simultaneous saccharification and fermentation (SSF) of potato starch by *Lactobacillus delbrueckii* with added glucoamylase (Tsai and Moon 1998). Prior to SSF, the crude starch was mixed with α -amylase and liquefied for 20 min at 103.5 °C. The authors predict that the process which eliminates the two-step starch hydrolysis and sterilizer steps will reduce both capital cost and process time.

The productivity of the classical batch reactor for lactic acid fermentation is lower than desirable for economically viable large-scale production. A great deal of research has been carried out on continuous fermentation processes over the past 10–15 years that promises to raise productivity. The research on continuous processes up to 1995 has been reviewed (Litchfield 1996).

Added productivity of lactic acid fermentations can be achieved by combining continuous systems with mechanisms that allow higher bacterial cell concentrations. Research is concentrated on two mechanisms: (1) membrane recycle bioreactors (MRBs) and (2) immobilized cell systems (ICSs). The MRB consists of a continuous stirred-tank reactor in a semiclosed loop with a hollow fiber, tubular, flat, or cross flow membrane unit that allows cell and lactic acid separation and recycle of cells back to the bioreactor. The results of a number of laboratory studies with various MRB systems demonstrate the effect of high cell concentrations on raising lactic acid productivity (Litchfield 1996). ▶ [Table 1.12](#) lists examples of published results employing various MRB systems.

The volumetric productivity (g of lactic acid/l·h) is usually greater than ten-fold that of batch or continuous processes. Ceramic tubular membranes have been used which are both steam sterilizable and resistant to mechanical stress (Xavier et al. 1995). Fermentation production of lactic acid directly from starch was optimized in an MRB using *L. amylovorus* (▶ [Table 1.12](#)). No saccharification or preliquefaction of starch

Table 1.12

Examples of lactic acid production in membrane recycle bioreactors

Bacterium	Type of membrane	Substrate	Product (g/l)	Cells (g/l-h)	Productivity (g of lactic acid/l-h)	Time of operation (h)	Yield (g of lactic acid/g substrate)	Reference
<i>L. delbrueckii</i> (<i>L. rhamnosus</i>)	Flat sheet	Glucose	59	118	65	52	0.95	Ohleyer et al. (1985)
<i>L. delbrueckii</i> (<i>L. rhamnosus</i>)	Hollow fiber	Glucose	40	8	12	220	0.76	Major and Bull (1988)
<i>L. delbrueckii</i>	Tubular ceramic	Glucose	90	136	36	90	0.82	Xavier et al. (1995)
<i>L. delbrueckii</i> (<i>bulgaricus</i>)	Hollow fiber	Lactose	117	63	84	8	0.99	Mehaia and Cheryan (1987)
<i>L. delbrueckii</i> (<i>bulgaricus</i>)	Hollow fiber	Lactose	89	40	22.5	280	0.89	Tejayadi and Cheryan (1995)
<i>L. helveticus</i>	Tubular with electrodialysis	Lactose	27	64	22	144	0.81	Boyaval et al. (1987)
<i>L. amylovorus</i>	Hollow fiber	Starch	42	39	8.4	240	0.88–0.9	Zhang and Cheryan (1994)

Table 1.13

Lactic acid production in immobilized cell reactors

Bacterium	Bioreactor and cell support	Substrate	Product (g/l)	Productivity (g of lactic acid/l-h)	Time of operation (days)	Yield (g of lactic acid/g of substrate)	Reference
<i>L. casei</i>	Repeated batch, with biofilm on plastic composite supports	Glucose	60	0.8 ± 0.19	72	0.77	Demirci and Pometto et al. (1995)
<i>L. casei</i>	Recycle batch, column with biofilm on polyethyleneimine foam-coated glass beads	Glucose	95	4.3–4.6	12	0.95	Senthuran et al. (1997)
<i>L. casei</i>	Repeated batch, with biofilm on plastic composite supports	Glucose	85–95	4.26–3.6	66	0.85–0.95	Ho et al. (1997)

was found necessary (Zhang and Cheryan 1994). In summary, the research with MRB systems demonstrates that this is a successful approach to fermentation because both a high productivity is achieved and a high concentration of lactic acid is removed in the final permeate. Long-term performance of these units at high cell densities, however, has been limited to about 10 days owing to filtration membrane clogging, which requires a cleaning operation or replacement of the membrane unit.

Research has been carried out employing immobilized cell systems (ICs) with the goal of improving lactic acid production. Bacteria are immobilized either by entrapment in gels such as alginate beads or carrageenan beads or, alternatively, by adsorption as a biofilm on the surface of supports such as porous glass, ceramic beads, or polypropylene composites (Table 1.13).

The results of the major investigations up to 1994 have been reviewed by Litchfield (1996). Normally, the immobilized cells

are exposed to the substrate-containing medium in a bioreactor where the high concentration of cells catalyzes the production of lactic acid. The spent medium with the lactic acid then passes to a recovery unit to remove the lactic acid. The medium is then renewed by adding back substrate and other nutrients and finally is recycled back to the bioreactor. Both the added sugars and the lactic acid recovered are at relatively high concentrations. In practice, the various gels used for entrapment of cells have softened, leaked cells or prevented rapid outward diffusion of the lactic acid, thus blocking cell metabolism. Also, plugging and clogging of column-shaped bioreactors often occurred. In addition, contamination of difficult-to-sterilize natural gels can be a problem. The use of lactic acid bacterial biofilms adsorbed on inert supports has been more successful (Table 1.13). Research trials with a composite support of 75 % polypropylene and 25 % agricultural materials and

L. casei in a repeated batch fermentation showed excellent biofilm stability for up to 72 days (Demirci and Pometto 1995). Using a different bioreactor configuration, *L. casei* cells on polyethyleneimine-coated foam glass beads yielded excellent results in a recycle batch fermentation. Both systems can produce an average of 4.3–4.6 g of lactic acid/l·h (Ho et al. 1997).

In general, the productivity of the ICSs is far lower than that of the MRB systems. However, the ICSs apparently have the advantage of long-term stability over the MRB systems. The advances in membrane-based separation and purification technologies combined with electrodialysis and ion exchange separation form the basis for scale-up large-volume production. A proprietary process employing these technologies for continuous fermentation of sugar for lactic acid production is under development by a major company in the United States (Datta et al. 1995).

Preliminary research has appeared demonstrating extractive lactic acid fermentation based on aqueous two-phase systems (ATPS). The idea is to provide a technology that simultaneously prevents product inhibition and enhances volumetric productivity. Basically, an ATPS involves an extractive step for removal of the product (lactic acid) at the same time it is being formed during the fermentation stage. For the extractive bioconversion to be effective, the product must be partitioned into the phase opposite the one preferred by the microbial cells. Using a two-phase system composed of polycation, polyethyleneimine (PEI), and a neutral polymer, hydroxyethylcellulose (HEC), successful lactic acid partitioning and fermentation by *L. lactis* was demonstrated (Kwon et al. 1996). Following batch fermentation, 75–85 % of the lactic acid was in the PEI layer, and 90 %

of the cells were in HEC layer under optimal conditions. Good product yields (0.7–0.85 g/g) and productivity (8–10 g of lactic acid/l·h) were reported in both batch and continuous fermentations. Other polymer pairs have been tested for a two-phase fermentation-extraction system (Planas et al. 1996). However, no scale-up fermentations or economic analyses of application of these approaches for commercial production have appeared.

Prospects

New Products and Future Demand for Lactic Acid

Up to 1994, the world demand for lactic acid reached about $60\text{--}65 \times 10^3$ t/year, with a predicted growth of about 12–15 % per year (Bahner 1994). The major use for lactic acid in the United States is for food applications (about 85 %), whereas the remainder is for industrial uses (Datta et al. 1995). Most likely, this situation will change rapidly during the twenty-first century.

Lactic acid is now recognized as an excellent feedstock in the chemical industry for new products. Based on the potential products from lactic acid (see Table 1.14), the demand for lactic acid in the future could reach $2.5\text{--}3.4 \times 10^6$ t/year. New technologies are under development for manufacturing lactic acid and for industrial scale processes for product synthesis (Fig. 1.12).

Research on membrane-based separation methods combined with electrodialysis forms the basis for new processes for lactic acid production. These technological improvements

Table 1.14

Lactic acid: potential products, volumes, and value

Product	Uses	US market ^a volume (10 ⁹ lb/year)	Selling ^a price (\$/lb)	Value (\$10 ⁶ /year)
Degradable plastics	Packaging, films	0.3–2.0 ^b	0.4–0.6 ^b	120–1,200
Oxychemicals:				
Propylene	Polymers, food deicers, humectants, plastic films, coatings, and plastics	0.8	0.55	440
Glycol		1.1	0.65	710
Acrylates		3.2	0.55	1,760
Propylene oxide				
"Green" chemicals and solvents:				
Esters	Plasticizers and food-processing packaging	0.1–0.2 ^c	0.5	50–100
Ester derivatives	Same as above	0.05–0.1 ^c	0.5	25–50
Plant growth regulators:				
Poly-L-lactates	Mulch film for vegetable and fruit crops	0.05–0.1 ^c	1.0	50–100
Total		5.6–7.5		3,155–4,360

From Datta et al. (1995), with permission

^aMarket volumes and prices are for 1991 (Chemical Marketing Reporter) unless otherwise stated. Prices and values are in US \$

^bEstimates from Battelle, SRI, Cargill (1993) announcement

^cArgonne's estimates

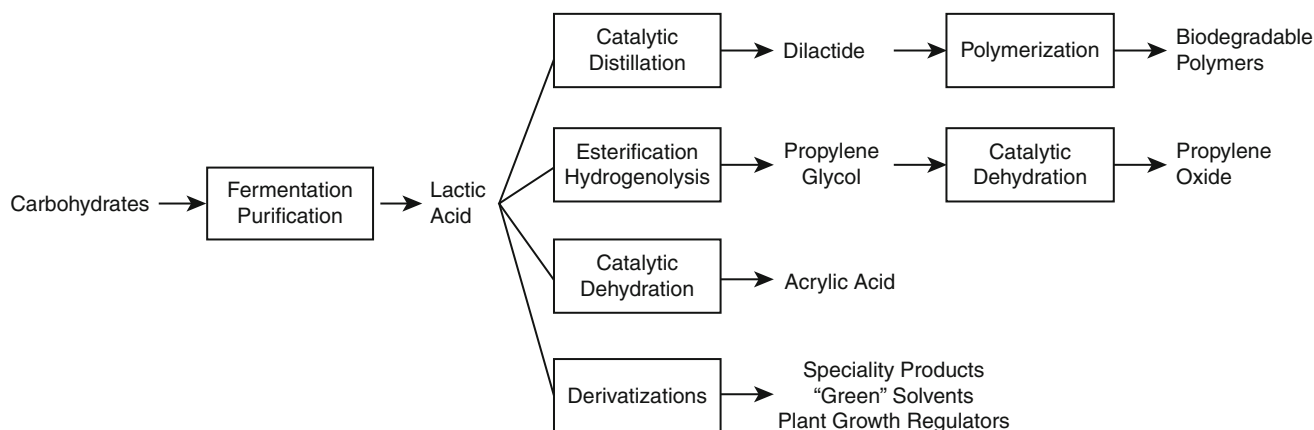

Fig. 1.12

Lactic acid: potential products and technologies (From Datta et al. (1995), with permission)

have led to proprietary large-scale production methods for obtaining purified concentrated lactic acid from carbohydrates without excess calcium sulfate (gypsum) or other salts in the waste stream. US agriprocessing companies are building large-capacity production plants for simultaneous fermentation and separation of lactic acid based on this technology (Datta et al. 1995).

Both DuPont and Cargill are developing large-scale manufacturing processes for conversion of lactic acid to lactides, glycolides, and prepolymers. Eventually, the goal is to develop commercial-scale processes for production of biodegradable polymers for a variety of uses. The lactide copolymers have a range of properties and promise to compete well with petroleum-based polymers such as polystyrene, polyvinyl chloride, and vinylidene (Tables 1.15 and 1.16).

Lactic acid also may be converted into a variety of other chemicals such as propylene glycol, propylene oxide, and acrylic acid by known technologies (Fig. 1.12). If potential uses and market volumes appear as predicted (Table 1.14), then commercial-scale manufacturing processes also must be developed. In the future, lactic acid esters, which are nontoxic and less volatile, may replace more toxic solvents now in use as plasticizers and films (Table 1.14). Consumer demand and regulatory agencies already favor safer aerosol-forming solvents.

Competitive Processes

Chemical synthesis of lactic acid from lactonitrile is the major alternative process for manufacture in competition with fermentation lactic acid. In 1995, synthetic lactic acid accounted for about 50 % of the total world lactic acid production (Litchfield 1996). The advantage of the chemical synthesis route is the ease of obtaining a highly purified lactic acid which is required for many industrial products. The synthetic lactic acid is a racemic mixture (DL), whereas fermentation lactic acid may be selectively D(−) or L(+) or DL depending on the organism catalyzing the conversion. Controlled optical purity as well as

chemical purity of lactic acid is vital for commercial production of lactide polymers with specific properties required for the desired applications and potential uses of the polymers. Also, optically active lactic and lactate esters may be applied to new chiral synthesis routes for specialty chemicals such as drugs and agrichemicals (Datta et al. 1995).

Fungal fermentation of carbohydrates to lactic acid is potentially competitive with the classical *Lactobacillus* fermentation. Presently, Archer Daniels Midland's fermentation facility in Illinois, in the United States, is producing lactic acid from enzyme-converted corn starch, using a "nonbacterial" proprietary fermentation process. The production capacity is reported as $10\text{--}20 \times 10^3$ t/year of lactic acid, but details of the process are not available. *Rhizopus* spp. grow aerobically utilizing glucose or sucrose to produce L(+)-lactic acid. Some species, such as *R. oryzae* and *R. arrhizus*, can convert starch or starch-containing complex substrates to L(+)-lactic acid. *Rhizopus* spp. are obligate aerobes and heterolactic. Thus, the highest theoretical yield of lactic acid is about 0.75 g per g of glucose. Practically, experimental yields of 0.5–0.72 g/g are observed, compared to 0.85–0.9 g/g for the *Lactobacillus* fermentations (Litchfield 1996). However, the yield of lactic acid can be improved, and production of side products reduced by the application of genetic engineering to the metabolic pathways. The advantage of the *Rhizopus* spp. is that they grow and produce lactic acid in an inorganic mineral medium containing only ammonia or nitrate as a nitrogen source and no amino acid or vitamin requirements. This property greatly simplifies the downstream separation and purification of the lactic acid product.

Future Lactic Acid Bacteria

The future commercial emphasis is on production of lactic acid as a bulk chemical converted from biomass by microbial fermentation. Clearly, future research employing genetic engineering will be aimed at converting bacteria into more efficient chemical reactors for this process. The desired properties of

■ Table 1.15

Comparison of a lactide copolymer with vinyl polymers

Property	Vinylidene chlorine molding compounds	85/15 copolymer of L-lactide/ ϵ -caprolactone	Flexible PVC
Tensile strength, psi	3,000–5,000	3,200	1,500–3,500
Elongation, %	up to 250	6–500	200–450
Initial modulus, psi	50,000–80,000	84,000	50,000–100,000
Impact strength, ft-lb/in.	0.3–1	No break	0.4–7
Hardness, shore D	50	87	20–76
Specific gravity ^{20/4}	1.65–1.72	1.26	1.16–1.35
Abrasion resistance	Excellent	Excellent	Excellent
DTA m.p., °C		133	None
Compression molding, °C	105–175	125–150	140–175
Ease of molding	Excellent	Excellent	Good
Weather resistance	Good	Fair to poor	Good
Lube oil resistance	Excellent	Excellent	Excellent
Solvents/nonsolvents	Resist most solvents	Benzene, chloroform/heptane, alcohol, and ether	Benzene, chloroform/heptane, alcohol, and ether
Mineral acid	Resistant	Resistant	
Caustic	Resistant	Attacked	

Abbreviations: PVC polyvinyl chloride, *psi* pounds per square inch, and DTA *m. p.* differential thermal analysis melting point
From Lipinsky and Sinclair (1986), with permission

■ Table 1.16

Comparison of a lactide copolymer with polystyrene

Property	Polystyrene	95/5 copolymer of L-lactide/ ϵ -caprolactone
Tensile strength, psi	7,000	6,900
Elongation, %	2	1.6
Initial modulus, psi	450,000	112,000
Impact strength, ft-lb/in.	0.25	0.36
Hardness, shore D	85	90
Specific gravity ^{20/4}	1.08	1.26
DTA m.p., °C	None	145
Compression molding, °C	130–200	160–170
Ease of molding, °C	Excellent	Good
Weather resistance	Good	Fair
Lube oil resistance	Swells	Excellent
Solvents/nonsolvents	BZ, CHCl ₃ , MEK/alcohol, ether, and heptane	BZ, CHCl ₃ , MEK/(swells) alcohol, ether, and heptane
Mineral acid	Resistant	Resistant
Caustic	Resistant	Attacked

Abbreviations: BZ benzene, MEK methyl ethyl ketone; and see Table 1.15 for definitions of other abbreviations
From Lipinsky and Sinclair (1986), with permission

a future-engineered lactic acid bacteria are listed in Table 1.17. Only the first four of these properties are characteristic of the present industrial strains of *Lactobacillus* and related lactic acid producers. The problems of productivity and product tolerance are limiting factors in batch fermentations. The desired high productivity and tolerance to lactic acid are now being dealt with using new continuous membrane-based fermentation-separation technology (FST), applied to commercial production. The last three properties listed (Table 1.17) limit the effective use of the *Lactobacillus* strains.

Transfer of metabolic pathways and phage-resistance properties between bacteria using genetic engineering technologies (GET) is available for developing future super bacteria. This new set of industrial lactic acid bacteria will probably not be based on the present *Lactobacillus*, inasmuch as overcoming the complex growth requirement is an enormous task. Conversion of a chosen bacterium into a true homolactic L(+)- or D(-)-lactic acid producer strain is now achievable through genetic engineering technology (GET).

Gluconic Acid

Introduction

Two reviews cover the microbial production processes for conversion of glucose to gluconic acid and its calcium and sodium salts (Milson and Meers 1985; Roehr et al. 1996). Hlasiwetz and

Table 1.17

Future lactic acid bacteria

Desired properties	Present bacteria (<i>Lactobacillus</i>)	Developing technologies
High yield, >0.9 g of lactic acid/g of substrate	Homolactic	GET
Optical purity D(−) or L(+) options	Yes	GET
High temp. (42–55 °C)	Grow and ferment	FST
Anaerobic metabolism	Yes	FST
Product tolerance	About 10 %	FST
High productivity >10 g of lactic acid/l-h	Low	FST
Broad substrate use (cellulose, starch, etc.)	Limited	GET
Grow in mineral salts	Complex requirements	GET
Virus infection control	Liable to infection	GET

Abbreviations: GET genetic engineering technologies; and FST fermentation and separation technologies

Habermann (1870) first identified gluconic acid as a major product of the chemical oxidation of glucose. Boutroux (1880), while studying the microbial fermentation of glucose in the presence of calcium carbonate, isolated calcium gluconate. The gluconic acid-producing organism was later identified as a strain of *Mycoderma aceti*, most probably a *Gluconobacter* sp. Forty-two years later, Molliard (1922) reported that gluconic acid was produced by *Sterigmatocystis nigra* (probably *Aspergillus niger*) during growth with sucrose. Within a few years, gluconic acid production was associated with many fungi, such as *Penicillium* species, strains of *A. niger*, and strains of aerobic bacteria such as *Pseudomonas*, *Gluconobacter*, and *Zymomonas*.

The list of uses of gluconic acid and its derivatives is astoundingly diverse and has continued to grow in the food, pharmaceutical, and metal treatment industries throughout the twentieth century (see section “Commercial Applications” in this chapter). As a result, much attention has been focused on processes for production of gluconic acid and its salts by oxidation of glucose. There are four categories of commercial processes: chemical processes, the *A. niger* process and other fungal processes, the *Gluconobacter* process and other bacterial processes, and the immobilized enzyme processes.

The chemical conversion of D-glucose to D-glucono- δ -lactone and thence to D-gluconic acid has been used in manufacturing processes. Electrochemical oxidation in the presence of bromide (Isbell et al. 1932) and oxidation with air or oxygen (employing a catalyst; deWilt 1972) are examples of methods in use. However, because of the appearance (during chemical production) of unwanted side products that require difficult downstream purification, the more specific microbial “fermentations” and other biochemical processes are definitely competitive.

Aspergillus niger was the major organism in the development of microbial processes for conversion of glucose to gluconic acid. Bernhauer (1924, 1928) demonstrated that selected strains of *A. niger* carried out this conversion in high yields when the acid produced was neutralized, usually by calcium carbonate. Research on the technology of gluconic acid production started in the US Department of Agriculture (USDA) in 1926. About this time at the USDA, a pilot plant process was developed for gluconic acid production using selected strains of *Penicillium luteum purpurogenum* in a surface-type “fermentation” (Herrick and May 1928). But the critically important development was the production of gluconic from glucose by the submerged culture technology using stirring and forced aeration in the reactor (May et al. 1934). With either *A. niger* or *P. luteum* used in the oxidation process, a 90 % yield in only 48–60 h was reported. Employing a strain of *A. niger* (strain 67) with the modern submerged reactor technology, pilot plant studies yielded 95 % conversion of glucose (in a 15–20 % solution) in 24 h (Moyer et al. 1937). The commercial-scale technique utilizes a 25 % glucose solution, achieves a 95 % conversion in the submerged reactor, and involves neutralization by calcium carbonate as well as reuse of mycelium in 24-h cycles. Sodium gluconate is the product desired for most commercial uses. Blom et al. (1952) developed the basic process for sodium gluconate production in which gluconic acid is neutralized (~pH 6.5) with sodium hydroxide during the microbial conversion. This process is essentially that used by most production plants today. A continuous gluconic acid production process was developed in Japan by Fujisawa Pharmaceutical Group (Yamada 1977). This process employed *A. niger* and was carried out using conventional fermentation techniques. In 1977, production of gluconic acid in Japan had reached 8,500 t/year.

Production methods employing the bacterial strains *Acetobacter* (*Gluconobacter*) were developed and patented early in the last century (Currie and Carter 1930; Verhave 1930). The genus *Gluconobacter* and the genus *Acetobacter* are closely related and are accepted as two separate genera in the family Acetobacteraceae, primarily based on the proposal by Asai (1968). The main distinction is that the *Acetobacter* sp. rapidly oxidize ethanol to acetic acid and only slowly oxidize glucose to gluconic acid, whereas *Gluconobacter* sp. rapidly oxidize glucose to gluconic acid. The *Gluconobacter oxydans* ATCC621H (formerly *A. oxydans*) was the most frequently used strain in early gluconic acid production processes. The family grouping Acetobacteraceae is supported by 16S ribosomal DNA sequence similarities of eight species (Sievers et al. 1994b). However, this molecular analysis does not present a convincing case for separation of *G. oxydans* from the species *Acetobacter*. The first production techniques employed a modified “quick vinegar” process used early in production of acetic acid (see the section “Acetic Acid” in this chapter). However, a more modern submerged fermentation process utilizing *Gluconobacter oxydans* was also developed (Currie and Finlay 1933). This process is very much like the present method used for vinegar acetic acid production by *Acetobacter* (see the section “Acetic Acid” in this chapter). Increases in gluconic acid concentration

and in productivity have been achieved in continuously performed processes combined with immobilization of *Gluconobacter* cells on carriers (Shiraishi et al. 1989a). Research on process development has proceeded and is covered in “Areas of Research and Development.”

Interest in a gluconic acid production process using a novel acetic acid bacterium, *Acetobacter methanolicus*, has emerged (Uhlig et al. 1986). *Acetobacter methanolicus* is a facultative methylotrophic bacterium that can grow on methanol as a sole carbon and energy source. Several patents document the possible future use of this organism (Babel et al. 1986, 1987, 1988, 1991).

Acetobacter diazotrophicus is an isolated aerobic nitrogen-fixing acetic acid bacterium (Gilles et al. 1989). It grows well in simple mineral salts medium and oxidizes glucose at high rates in acid conditions (pH 3.5) and (unlike *G. oxydans*) in the presence of high concentrations of gluconic acid (Attwood et al. 1991). Because of these characteristics, the use of *A. diazotrophicus* is of interest for bulk production of gluconic acid.

A fourth bacterial candidate, *Zymomonas mobilis*, can rapidly convert mixtures of glucose and fructose to gluconic acid and sorbitol with almost a 100 % yield. This coupled oxidation-reduction process depends upon the *Z. mobilis* enzyme glucose-fructose oxidoreductase present in cells grown with these sugars (Zachariou and Scopes 1986). Several protocols for cell treatment and cell immobilization are under study for development of commercial processes leading to large-scale production of the two products sorbitol and gluconic acid (see section “Areas of Research and Development” in this chapter).

A fourth process for gluconic acid production is the direct use of the enzyme glucose oxidase (GO) as a catalyst to carry out the rather simple reaction:

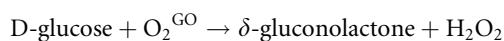

Glucose oxidase isolated from *Aspergillus* or other fungi has been immobilized on a number of supports, and studies show that it is quite sensitive to the hydrogen peroxide formed during glucose oxidation. Therefore, a number of methods for coimmobilizing GO together with catalase have been developed (e.g., Bucholz and Gödelmann 1978). This approach is, in theory, similar to the immobilization of *A. niger* mycelia, either flocculated (as pellets) or covalently bound to various supports (Sakura et al. 1989). Systems employing other enzymes that oxidize glucose also have been studied. A coupled system that simultaneously oxidizes glucose to gluconic acid and transfers electrons via NAD(H) to reduce fructose to mannitol has been proposed. Bacterial glucose dehydrogenase (GH) and mannitol dehydrogenase (MH) from different organisms have been immobilized to carry out the following reactions:

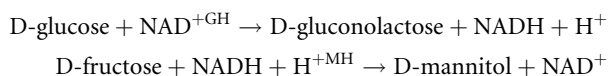

Membrane reactors have been employed that allow retention and recycling of NAD (Howaldt et al. 1988, 1990; Oben et al.

1996). This approach is probably technologically too complex to permit scale-up for bulk commercial production. A more likely candidate for commercial production by an immobilized enzyme process is the use of the single enzyme glucose-fructose oxidoreductase (GFOR) of *Zymomonas mobilis* (Nidetzky et al. 1997; Silva-Martinez et al. 1998).

In summary, considering the production of gluconic acid, the *A. niger* process appears to dominate present-day manufacturing methods. Likewise, the continuing research and development efforts utilizing the *Gluconobacter* process are clearly evident. In addition, the emergence of two new bacterial processes employing *A. methanolicus* and particularly *Z. mobilis* has opened promising new routes for production that may be competitive in the future. These bacterial processes are emphasized in the sections below.

Scientific Background

D-gluconic acid is one of the oxidation products of D-glucose. There are three major reactions catalyzed by microorganisms for oxidation of D-glucopyranose to yield D-glucono- δ -lactone by removing two hydrogens (Fig. 1.13).

D-glucono- δ -lactone is in equilibrium with gluconic acid in water solution. Also, gluconic acid is in equilibrium with D-glucono- γ -lactone; in addition, gluconic acid ionizes in water to yield a gluconate anion and a hydrogen ion. Thus, a water solution of gluconic acid is a rather complex system depicted at the bottom of Fig. 1.13. The equilibria shown influence the apparent acid dissociation constant with an approximate pKa of 3.7. Thus, gluconic acid acts as a weak acid in solution and is highly soluble in water. The equilibria between the gluconolactones and the free gluconic acid are attained very slowly. However, a lactonase, produced by most glucose-oxidizing bacteria and fungi, catalyzes a rapid hydration of the lactones (Fig. 1.13). The sodium salt of gluconic acid has the property of forming complexes with various metal ions. The high metal sequestering action of sodium gluconate has led to important commercial uses in many varied processes and products (see section “Commercial Applications” in this chapter).

The biochemical pathway of glucose oxidation to gluconic acid by *Aspergillus niger* and most other fungi is catalyzed by glucose oxidase followed by a catalase which in turn removes H₂O₂ (Fig. 1.13). The details of the physiology and biochemistry of the fungal process for gluconic acid production were reviewed by Roehr et al. (1996) and will not be covered here.

The bacteria employed or in processes under development for gluconic acid production are listed in Table 1.18. *Gluconobacter oxydans*, *A. methanolicus*, and *A. diazotrophicus* are closely related strains (Sievers et al. 1994b). All three species utilize the membrane-bound D-glucose dehydrogenase enzyme pathway for oxidation of D-glucose to D-gluconic acid (Fig. 1.13).

The biochemistry and suggested bioenergetics of the glucose-oxidizing system and respiratory chain for *Gluconobacter*

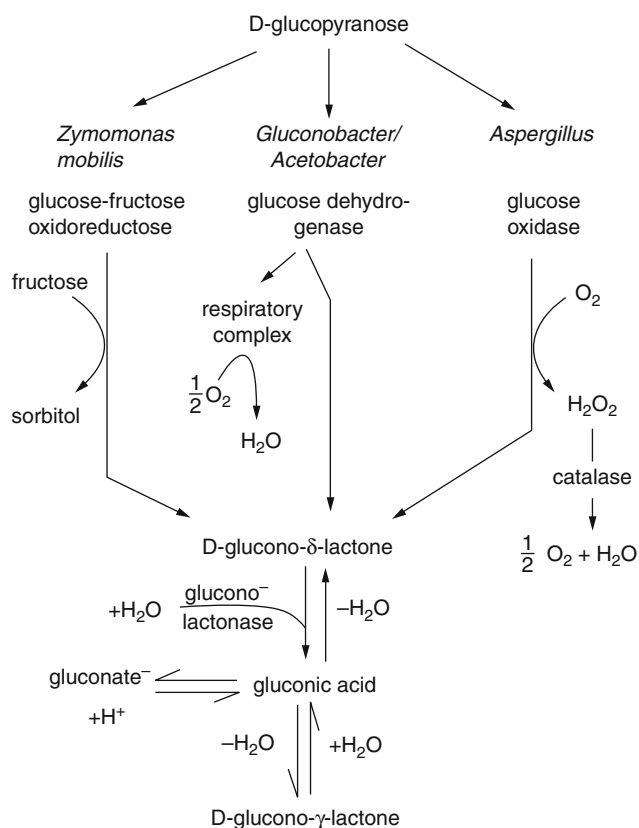

Fig. 1.13
Major routes of enzymatic oxidation of glucose to gluconolactone by bacteria and fungi. Gluconolactonase, present in all of these organisms, catalyzes formation of gluconic acid. Gluconic acid is in equilibrium with the lactones and gluconate in water solution

and *Acetobacter* have been extensively studied and reviewed (Matsushita et al. 1994). **Figure 1.14** is a cartoon of the proposed arrangement of the elements of the glucose-oxidizing system.

These bacteria produce gluconic acid from glucose mainly via a membrane-bound enzyme, D-glucose dehydrogenase (GDH), with pyrroloquinoline quinone (PQQ) attached as a prosthetic group. *Gluconobacter oxydans* also produces varying amounts of 2-keto-D-gluconate and 2,5-diketo-D-gluconate by further oxidation of gluconic acid catalyzed by the two enzymes gluconate dehydrogenase (GADH) and 2-keto-D-gluconate dehydrogenase (2KGADH). These two enzymes are also membrane bound, each containing three subunits: a cytochrome *c*, a flavoprotein with a covalently bound FAD, and a third subunit. These oxidations take place on the outer surface of the cytoplasmic membrane. Mostly gluconic acid together with smaller amounts of the other two oxidation products accumulates in the beers. The dehydrogenases are linked to the respiratory chain through ubiquinone (Q_{10}) in the cytoplasmic membrane (**Fig. 1.14**). A set of $NADP^+$ -dependent GDH and GADH enzymes is located in the cytoplasm, where it functions to interchange glucose and the gluconates. D-glucose is metabolized primarily through the Embden-Meyerhof pathway and tricarboxylic acid (TCA) cycle by most *Acetobacter* sp. Alternatively, *Gluconobacter* sp. convert glucose to gluconate, which is metabolized through the pentose phosphate pathway (**Fig. 1.14**). Gluconate production by *G. oxydans* is largely catalyzed by the membrane-bound GDH which has 30 times the activity of the cytoplasmic $NADP^+$ -dependent GDH (Pronk et al. 1989). *Gluconobacter* and some species of *Acetobacter* can accumulate high concentrations of gluconic acid and smaller

Table 1.18
Bacteria used in developing processes for gluconic acid production

Organism	Properties	References
<i>Gluconobacter suboxydans</i> or <i>G. oxydans</i> subsp. <i>suboxydans</i> or <i>G. melanogenus</i>		
ATCC 621H, IFO 3290	Grows with vitamins	Sievers et al. (1994b)
IF03293, ATCC9937	Produces ketogluconates and gluconic acid from glucose	
<i>Acetobacter methanolicus</i>		
MB58, IMET10945	Produces only gluconic acid from glucose	Uhlig et al. (1986)
LMG 1668	Grows on methanol, requires pantothenic acid	Sievers et al. (1994c)
<i>Acetobacter diazotrophicus</i>		
ATCC 49037	Can grow aerobically with N_2 as sole N source Simple mineral medium	Gilles et al. (1989)
<i>Zymomonas mobilis</i>	Produces ketogluconates and gluconic acid from glucose	
DSMZ473	Produces only gluconic acid and sorbitol from glucose	Zachariou and Scopes (1986)
Strains ZM6, ATCC 29191	and fructose	

Abbreviations: ATCC American Type Culture Collection, Rockville, MD, DSMZ Deutsche Sammlung von Mikroorganismen und Zellkulturen, Braunschweig, Germany; IFO Institute for Fermentation, Osaka, Japan, IMET Institute für Mikrobiologie und Experimentelle Therapie, Jena, Germany, LMG Laboratory of Microbiology, University of Ghent, Belgium; and ZM Zentralinstitut für Mikrobiologie und Experimentelle Therapie, Jena, Germany

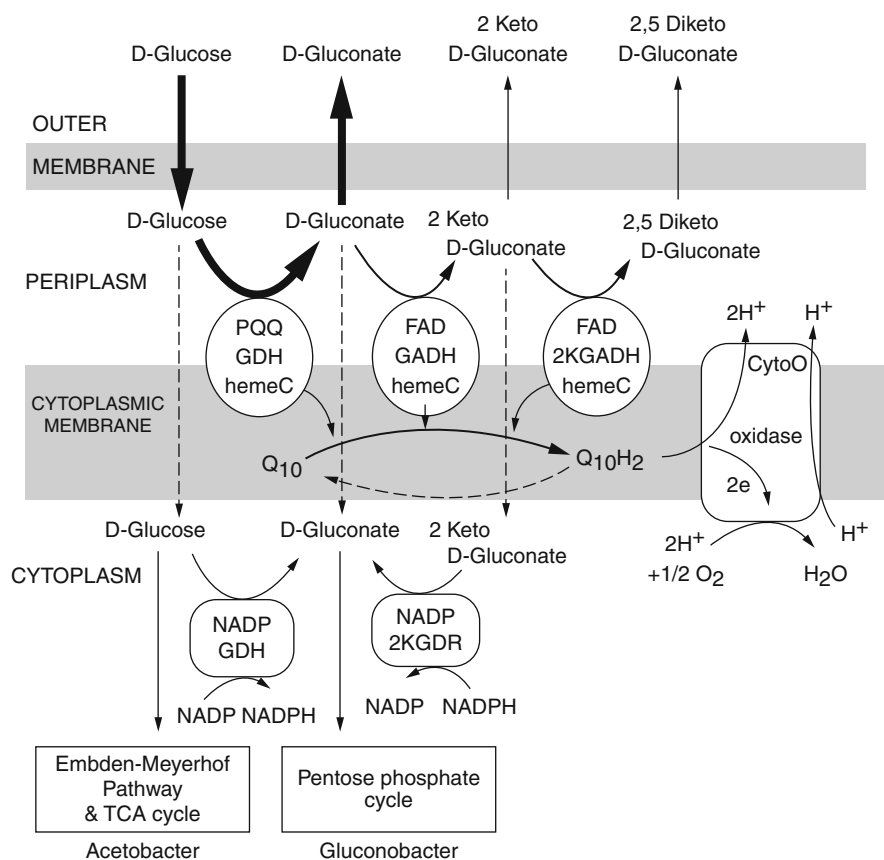

■ Fig. 1.14

Oxidation of glucose to gluconic acid by *Gluconobacter* and *Acetobacter*. Quinoprotein D -glucose dehydrogenase (GDH) and flavoproteins D -gluconate dehydrogenase (GADH) and 2-keto- D -gluconate dehydrogenase (2kGADH) are located on the outer surface of the cytoplasmic membrane. Cytochrome o (Cyto O) accepts electrons from the dehydrogenases via ubiquinone (Q_{10}) and cytochrome c (hemeC). Ubiquinol (Q_{10}H_2) is oxidized by cytochrome o oxidase (or Q oxidase) to generate a proton gradient. NADP-dependent D -glucose dehydrogenase (GDH) and NADP-dependent 2-keto- D -gluconate reductase (2KGR) work in the cytoplasm (Redrawn from Matsushita et al. (1994), with permission)

amounts of ketogluconates outside the cells. The oxidative reactions carried out by the sugar-oxidizing systems are coupled to the respiratory chain in which the electron transfer can develop a proton-electrochemical gradient across the cytoplasmic membrane, as diagrammed in Fig. 1.14. The proton gradient is used for ATP production and energetic events for cell growth and maintenance. But it has been shown that the coupling of glucose oxidation to the growth yields for *G. oxydans* is very inefficient at pH values less than 5.0 and at high glucose concentrations (Olijve and Kok 1979). Thus, a property of the respiratory chains of both *Gluconobacter* and *Acetobacter* is the rapid oxidation of high concentrations of alcohols and sugars while not permitting a high rate of energy generation. How is the potential for producing or utilizing the proton gradient (shown in Fig. 1.14) somehow uncoupled? In the case of *Gluconobacter*, a bypass, cytochrome δ oxidase system, is apparently induced at low pH, which allows a high rate of sugar (or alcohol) oxidation without producing a large proton gradient (Matsushita et al. 1994). But many *Acetobacter* spp. do not produce the bypass cytochrome oxidase system, and

it remains unclear how uncoupling of energy production occurs. These acetic acid bacteria have evolved to live in specific environments, such as surfaces of fruit and flower parts, where high concentrations of sugars and alcohols exist under aerobic conditions.

The further oxidation of gluconic acid to the ketogluconic acids by *Gluconobacter* or *Acetobacter* (illustrated in Fig. 1.14) is a potentially undesirable reaction when using these organisms for gluconic acid production. Suppression of most ketogluconate formation has been achieved by maintaining the pH at low levels (Roehr et al. 1996). The best results for gluconate production by *G. oxydans* depend upon the presence of high glucose concentrations, low pH, and high aeration.

Uhlig et al. (1986) described a novel acetic acid bacterium (*A. methanolicus*) that is a facultative methylotroph (Table 1.18). This pink-pigmented bacterium grows well on methanol or glycerol or glucose in a mineral medium containing only pantothenic acid as a growth factor. More important, glucose is strongly oxidized to gluconate, but 2-, 5-, or 2,5-ketogluconates are not formed. Based on 16S-rRNA sequences,

A. methanolicus was found to be closely related to other species in the genus *Acetobacter* and also to *G. oxydans* (Sievers et al. 1994c). *Acetobacter methanolicus* is different from other acetic acid bacteria in that it contains a methanol oxidase respiratory chain, as do other methylotrophs, in addition to sugar and alcohol oxidase respiratory chains. The methanol oxidase system consists of methanol dehydrogenase, which is a quinoprotein dehydrogenase (PQQ), and cytochromes c_L and c_H located free in the periplasm together with a membrane-bound cytochrome c oxidase which is either cytochrome co or aa_3 (Matsushita et al. 1994). In contrast, as depicted in Fig. 1.14, all of the primary dehydrogenases that are part of the sugar- and ethanol-oxidizing systems are membrane-bound and donate electrons to ubiquinone and a terminal ubiquinol oxidase such as cytochrome o , a , or d . Methanol is assimilated as formaldehyde using the ribulose monophosphate pathway through fructose-1, 6-biphosphate.

An interesting aerobic nitrogen-fixing bacterium, *A. diazotrophicus*, was isolated from sugarcane in Brazil. DNA-rRNA hybridization placed this organism in the genus *Acetobacter* (Gilles et al. 1989). Additional characteristics of *A. diazotrophicus* include growth on a simple mineral media, high rates of gluconic acid formation, growth and gluconic acid production at high glucose concentrations of 15 %, and at low pH, down to pH 3.5. These properties indicate that *A. diazotrophicus* may be of interest in commercial production (Attwood et al. 1991). In nature, *A. diazotrophicus* forms a symbiotic association with the sugarcane plant. During bacterial nitrogen fixation, about one-half of the fixed nitrogen is exported and made available as an organic nitrogen source for the host. The plant provides mainly sugars that are oxidized by the bacterium, some of which provide carbon and energy for growth. Glucose metabolism in *A. diazotrophicus* (like in *G. oxydans*) proceeds exclusively by the pentose-phosphate pathway. No enzymes peculiar to the Embden-Meyerhof or Entner-Doudoroff pathways were detected (Attwood et al. 1991). However, the major portion of the glucose is oxidized via the membrane-bound PPQ-GDH and cytochrome quinol oxidase system. This oxidation pathway must provide a means to maintain an anaerobic environment within the cell so that the O_2 -sensitive nitrogenase remains active. When bacteria are grown at low NH_3 (1 mM), the glucose dehydrogenase activities are 6.8- to 10-fold higher than when cells are grown in high NH_3 (40 mM). Isolated membranes from bacteria grown with low NH_3 showed an equivalent higher glucose oxidase activity (Flores-Encarnacion and Contreras-Zentella 1999). Thus, the respiratory system appears to be adjusted for scavenging oxygen to protect the nitrogenase, considering nitrogenase activity is much higher in cells with low NH_3 and growth is N_2 dependent.

The well-known ethanologenic bacterium, *Zymomonas mobilis*, has attracted attention as a candidate for development of processes for gluconic acid production (Table 1.18). Using glucose-fructose oxidoreductase (GFOR), an enzyme with a tightly coupled NADP as a hydrogen carrier (Fig. 1.15), this organism can convert a mixture of glucose and fructose, or sucrose, into glucono- δ -lactone and sorbitol.

In addition, the enzyme glucono- δ -lactonase (GL) ensures rapid hydrolysis of the lactone to gluconic acid (Zachariou and Scopes 1986). Under normal conditions, the gluconate is taken up by these cells, phosphorylated, and utilized via the Entner-Doudoroff metabolic pathway for energy and carbon compounds required for growth. However, procedures are under development to permeabilize pregrown cells for production of gluconic acid and sorbitol, beginning with high concentrations of glucose and fructose (Roehr et al. 1996). Permeabilized cells leak their cofactors such as ATP and NADH, and thus, the gluconic acid produced is not further metabolized. Silveira et al. (1999) reported that they obtained high yields of gluconic acid and sorbitol with untreated cells of *Z. mobilis* when high concentrations of glucose plus fructose (650 g/l) were present. The high yields of gluconic acid were found to be due to inhibition of normal metabolism, permitting diversion of most substrates through the GFOR/GL pathway (Silveira et al. 1999).

Zymomonas mobilis can grow anaerobically in media containing very high concentrations of sugars, such as glucose and sucrose. In natural habitats, such as fruit juices, plant saps, and honey, the bacteria may encounter dry periods producing environments with high concentrations of sugars. It was demonstrated that sorbitol promotes growth of *Z. mobilis* in high-sugar solutions. It was proposed that probably sorbitol functions to counteract osmotic stress by acting as a compatible solute (Loos et al. 1994). The enzyme GFOR is located in the periplasm of *Z. mobilis* and makes up about one percent of the total cell protein (Fig. 1.15). The GFOR/GL system has a dual role. It converts fructose into sorbitol, which acts as a compatible solute permitting growth and survival of *Z. mobilis* in solutions of 30 % sugar or higher. Simultaneously, glucose is converted into gluconic acid, some of which may be transported into the cell, phosphorylated, and become available to the Entner-Doudoroff metabolic pathway for cell growth (Fig. 1.15). Clearly, the bulk of both sorbitol and gluconic acid exits the cell under conditions where metabolism is blocked and fructose plus glucose concentrations are high.

Commercial Applications

Uses of Gluconic Acid and Gluconates

Brief summaries are found in Milson and Meers (1985) and Roehr et al. (1996). D-gluconic acid is a nontoxic and noncorrosive weak acid that is very soluble in water. It also forms water-soluble complexes with heavy metal and alkaline metal cations. Because gluconic acid is considered either a safe food additive or even a "food" in most countries, it has been of use in many processes related to the food industry. In the dairy industry, gluconic acid added to cleaners prevents calcium salt deposition in milking machinery and milk storage vessels. It is used in gentle metal-cleaning operations for aluminum and steel containers and equipment in food-processing plants. Gluconic acid addition to various foods and beverages prevents

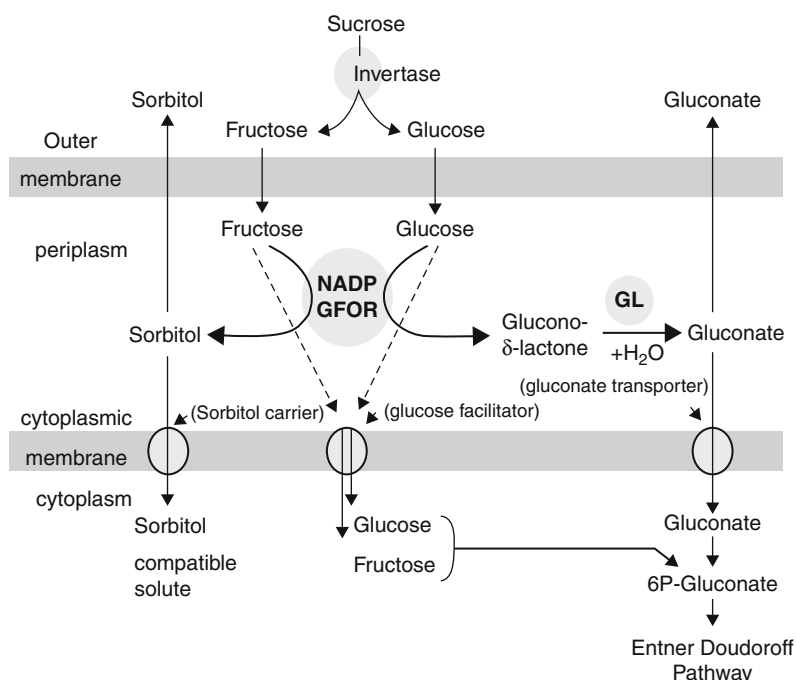

■ Fig. 1.15

Zymomonas mobilis production and utilization of gluconate and sorbitol from glucose and fructose. Sucrose may be hydrolyzed to glucose and fructose by an extracellular invertase. The periplasmic enzyme glucose-fructose oxidoreductase (GFOR) with a tightly bound NADP converts the two sugars to D-gluconolactone and D-sorbitol. Gluconolactone is hydrolyzed to gluconate (gluconic acid) by a periplasmic gluconolactonase (GL). During normal metabolism, gluconate is utilized for carbon and energy via the Entner-Doudoroff pathway. Some glucose and fructose also are utilized. The sorbitol taken into the cell acts as an osmoprotectant. When normal metabolism is blocked, gluconate and sorbitol are manufactured and exit the cell's periplasm in equimolar amounts (Redrawn from Loos et al. (1994), with permission)

cloudiness, complexes trace amounts of heavy metals, and improves the food by adding a mild sourness to the taste. Gluconic acid is usually marketed as a 50 % water solution, whereas the D-glucono- δ -lactone is commercially available as a crystalline solid. The glucono- δ -lactone is added as a slow-acting acidulant in baking powders for prepared instant cake mixes or instant bread mixes. Glucono- δ -lactone also is added during production of cured meat products such as in sausage preparations.

Sodium gluconate is the major commercial product used today, available either as a solid or in solution. The multiple uses of sodium gluconate depend upon its sequestering action with calcium, magnesium, and iron in the presence of alkaline solutions of sodium carbonate or sodium hydroxide. For example, cleaning solutions are marketed to remove oxide scales or paint and lacquer residues from metal or glass surfaces. Also, sodium gluconate solutions are used in the textile industry to prevent iron deposition. Sodium gluconate acts as a plasticizer and a retardant of the setting process when mixed into concrete. Calcium gluconate is widely used for antacid and calcium supplement preparations. Ferrous gluconate is used in dietary iron supplement preparations. Pharmaceutical preparations containing nitrogen bases are often marketed as gluconates, as are disinfectants such as chlorhexidine gluconate.

Industrial Production

The total world production of gluconic acid and gluconate in 1996 was estimated as 100–120 $\times 10^6$ lbs/year, of which 80 % was sodium gluconate (Roehr et al. 1996). The standard for commercial production of gluconic acid or gluconates is the *Aspergillus niger* process. Although this process is basically a biochemical conversion, it is presently competitive with chemical, electrochemical, or catalytic oxidation techniques because of their lower yields and side reactions.

The *A. niger* process is presently superior to the older *Gluconobacter* and *Acetobacter* processes for a number of reasons summarized here and previously mentioned (Milson and Meers 1985; Roehr et al. 1996). First, the requirements for *A. niger* growth are only mineral salts, a carbon source (such as glucose), and aerobic conditions. In contrast, the *Gluconobacter* species usually require a number of vitamins for growth. Secondly, for *A. niger*, the theoretical yield of gluconic acid from glucose is 100 %, although a practical yield is usually between 90 % and 95 %. The yield for *Gluconobacter* is usually lower (about 75–80 %) because of further enzymatic oxidation of gluconic acid to 2-keto-gluconate and 2,5-diketogluconate (Fig. 1.14). By careful attention to maintaining a moderately high glucose concentration and controlling the pH, the appearance of keto

acids can be minimized to less than 10 % of the product (Noury and Van der Lande 1962). But these keto acids must then be removed during downstream processing. Thirdly, pregrown *A. niger* mycelia suspended in production media with glucose (250–380 g/l) at pH 6.5 will produce almost 95 % gluconic acid at a productivity of 13 g/l·h, whereas strains of *Gluconobacter* are usually sensitive to glucose concentrations greater than 100 g/l. Ziffer et al. (1971) described a fed-batch method by which *A. niger* converted glucose (600 g/l) to gluconic acid in 60–70 h. Crystallization of the sodium gluconate was prevented by allowing the pH to slip down to 3.2–3.5 during the process. In summary, the *A. niger* process is used for commercial production because it can produce (at a high productivity) a high yield of gluconic acid or gluconates in a relatively pure state requiring a minimum of downstream processing or purification. However, the competitive position of the *A. niger* process has been challenged by two new bacterial processes (see section “Areas of Research and Development” in this chapter).

The selling price of gluconic acid (50 % solution, technical grade) was \$0.50–0.56/lb and of sodium gluconate (powder, technical grade) \$0.66–0.70/lb (Anonymous 2000).

Areas of Research and Development

Gluconobacter and Acetobacter Strains and Process Development

The bacterial strains presently being considered for incorporation into future processes for gluconic acid production are listed in Table 1.18. Initially, *G. oxydans* was used for production; it became evident that this organism presents important barriers to commercial process development.

First, the rapid growth requirement for vitamins and (for some strains) other organic nitrogen sources complicates the growth medium and later the downstream purification of the final product. Second, this bacterium is sensitive to low pH and to high concentrations of glucose and gluconic acid, resulting in low productivity and low final concentrations of gluconic acid in the beer. Third, the significant further oxidation of gluconic acid to 2-keto and 2,5-diketo-gluconate lowers the final yield and adds by-products that must be removed in later purification.

Process development and employment of alternative bacterial strains have bypassed some of these problems. Shiraishi et al. (1989b) investigated continuous production of gluconic acid with *G. suboxydans* IFO 3290 immobilized by adsorption on ceramic honeycomb monoliths. This type of ceramic with uniform 1- or 2-mm channels was found to be ideal for allowing rapid gassing (up to 900 cm³/min) as well as effective immobilization and metabolism by aerobic bacteria. Using a laboratory-scale ceramic reactor (immobilized *G. suboxydans*), a continuous conversion of glucose (100 g/l) was performed for 30 days, during which time the adsorbed cells remained stable (Fig. 1.16).

A gluconic acid yield of 84.6 % and glucose conversion of 94 % were achieved. The calculated productivity of 26.3 g/l·h was the

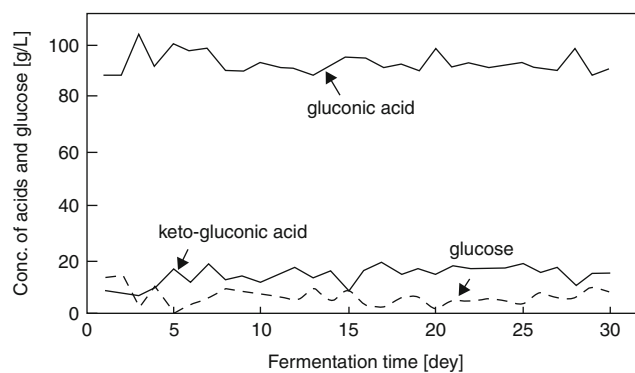

Fig. 1.16 Continuous production of gluconic acid from glucose by *Gluconobacter suboxydans* immobilized by adsorption on a ceramic honeycomb monolith reactor. Production was for 1 month at glucose, 100 g/l; reactor residence time, 3.5 h; and aeration rate, 900 cm³/min. The high productivity was 26.3 g/l·h, with a yield of 84.6 % gluconic acid (From Shiraishi et al. (1989b), with permission)

highest ever reported for *Gluconobacter*. Unfortunately, the production of ketogluconic acid was about 9 %. Attempts to reduce the ketogluconate concentration using this continuous immobilized cell method (changing the system to a three-stage reactor) were only partially successful (Shiraishi et al. 1989a).

Transposon Tn5-induced mutagenesis of *G. oxydans* was demonstrated (Gupta et al. 1997). Using this method, Gupta et al. (1999) have produced a mutant of *G. oxydans* ATCC 9937 (mutant C11) that is defective in gluconic acid dehydrogenase (GADH) and thus produces only gluconic acid from glucose without further oxidation of gluconic acid to 2-ketogluconate or 2,5-diketogluconate (see Fig. 1.14). Mutant C11 will certainly be attractive for development of a gluconic acid production process free of ketogluconate synthesis.

During the 1980s and 1990s, the Institute of Biochemistry in Leipzig began developing a process for gluconic acid production carried out with a methanol-utilizing strain *Acetobacter methanolicus* MG58 (IMET 10945T; Babel et al. 1986, 1991). The organism was grown on methanol, and the growth process ended owing to a deficiency of nitrogen and phosphorous. Cells (5–20 g of dry biomass per liter; BM) were suspended in the reactor vessel (F), and 150–250 g of glucose/l was added. During the batch phase (10–20 h), glucose was converted into gluconic acid, and the pH dropped to about 1.5–2.0. A continuous process was started, adding glucose (G) to the recycled permeated stream to maintain a level of gluconic acid at 200 g/l (CGA) in the reactor (Fig. 1.17).

Even at this high concentration of gluconic acid, the *A. methanolicus* cells, when continuously fed glucose, maintained a synthesis rate of gluconic acid at 20–30 g/l·h for 7 days (Poehland et al. 1993). The medium retention time in the reactor (F) and the permeate stream rate were controlled by pumps in the recycle circuit, which runs through a microfiltration module (MF). This arrangement continuously

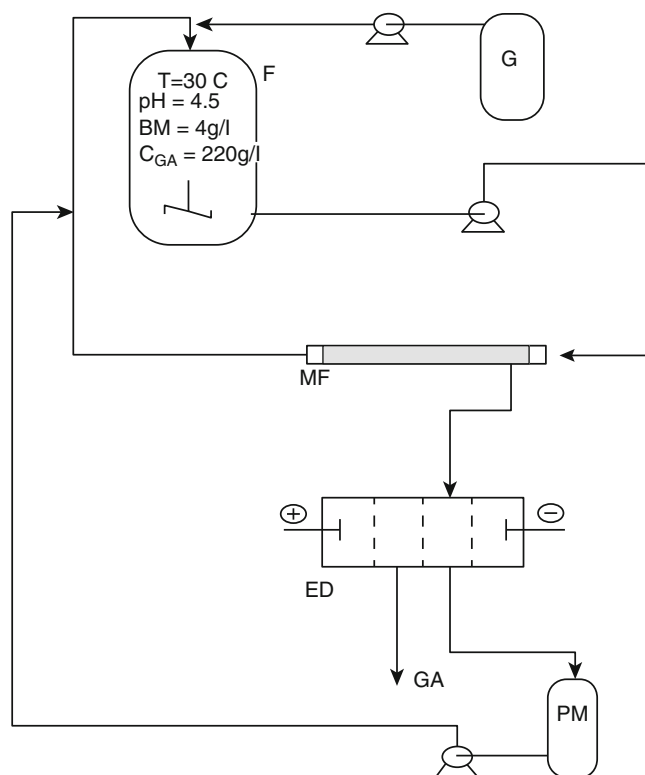

■ Fig. 1.17
Flow diagram of the gluconic acid synthesis process utilizing *Acetobacter methanolicus* (See the text for details. Redrawn from Poehland et al. (1993), with permission)

removes gluconic acid and other ingredients from the medium. The ultrafiltration output was passed continuously into a electro-dialysis apparatus (ED) to concentrate and purify the gluconic acid (GA). Optimization experiments were carried out in a laboratory-scale system with a 30-l reactor vessel. ▶ Figure 1.18 illustrates a continuous gluconic acid process employing *A. methanolicus* and lasting more than 5 days.

The published results are encouraging for further process development because this organism can withstand high concentrations of gluconic acid and glucose while continuously producing gluconic acid at high rates and at low pH values. Most important, the formation of 2-ketogluconate or 2,5-diketogluconate does not occur using this organism so that downstream removal of these by-products is unnecessary (Uhlig et al. 1986).

Acetobacter diazotrophicus, an isolated nitrogen-fixing acetic acid bacterium, shows high rates of gluconic acid production in preliminary studies (Attwood et al. 1991). In contrast to *G. oxydans*, *A. diazotrophicus* grows rapidly on simple mineral medium, tolerates acid to pH 3.5, and also tolerates high glucose and gluconic acid concentrations greater than 150 g/l. Apparently, aerobic utilization of dinitrogen at low ammonia concentrations depends upon an extremely high rate of respiratory electron transport utilizing glucose oxidation coupled to oxygen uptake (Flores-Encarnacion and Contreras-Zentella 1999). The physiologic conditions for a maximum rate

of gluconic acid production using this bacterium may be developed easily, considering a simple batch culture with 150 g of glucose/l at high ammonia produced an 80 % yield of gluconic acid at a productivity of about 15 g/l-h (Attwood et al. 1991). Unfortunately, *A. diazotrophicus* produced some 2-ketogluconate during gluconic acid production. However, genetic methods are available to knock out the gluconate dehydrogenase gene or develop mutant strains as reported for *G. suboxydans* (Gupta et al. 1999).

***Zymomonas mobilis* Process for Gluconic Acid and Sorbitol Production**

Zymomonas mobilis contains the periplasmic enzyme glucose-fructose oxidoreductase (GFOR) together with gluconolactonase (GL; Zachariou and Scopes 1986). (See section ▶ “Scientific Background” of gluconic acid production for a description of the biochemistry and physiology of the *Z. mobilis* system.) Subsequently, it has been shown that this organism can totally convert equimolar fructose and glucose solutions of over 50 % into sorbitol and sodium gluconate. The advantages of *Z. mobilis* for process development are:

1. No requirement for high aeration rates in contrast to aerobic processes using *A. niger* or *G. suboxydans*.
2. Productivity is enhanced by high concentrations of sugars.
3. Both sorbitol and sodium gluconate have industrial value and can be separated downstream (Chun and Rogers 1988).

The chemical technology for manufacture of sorbitol requires H₂ gas reduction at high pressure (40–50 atm) and high temperature (140–150 °C) of a 70 % glucose solution with a Ni²⁺ ion catalyst. The sorbitol syrup produced must be passed through several ion exchangers to reduce the residual nickel below 5 ppm prior to use of the sorbitol in the food industry (Phillips 1963). In contrast, under the mild conditions, *Z. mobilis* produces equimolar quantities of gluconic acid (or sodium gluconate) and sorbitol at high yields and high productivity. Also, considering selling prices, production of sorbitol (powder, \$0.73–0.96/lb, or crystals, \$0.73–1.03/lb) from fructose (powder, \$0.39/lb) rather than glucose (powder, \$0.51–0.54/lb) as a starting material may be more economical (Anonymous 2000).

Zymomonas mobilis normally utilizes much of the gluconate produced for metabolism via the Entner-Doudoroff pathway (see section ▶ “Scientific Background” in this chapter). To develop a process that produces high quantities of both gluconate and sorbitol, the metabolic utilization of gluconate must be suppressed or bypassed. Taking advantage of the periplasmic position of the GFOR and GL enzymes together with methods for preventing metabolism of gluconic acid, three approaches have been used. First, it was found that *Z. mobilis* cells treated with toluene were permeabilized and thus leaked cofactors such as NAD and NADP. These cells were unable to metabolize gluconate but retained the full ability to convert glucose to gluconate. This was because the NADP cofactor remains tightly coupled to

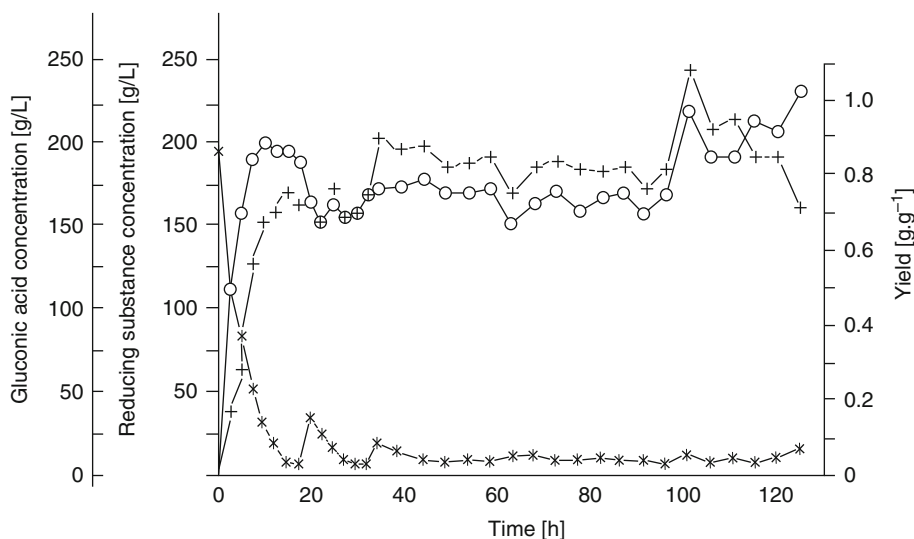

Fig. 1.18

An example of a continuous process for conversion of glucose to gluconic acid by *Acetobacter methanolicus*: $-o-$ yield, $--+$ gluconic acid concentration, $-*$ reducing substance concentration (glucose) (From Poehland et al. (1993), with permission)

the GFOR enzyme. Table 1.19 illustrates data from a number of workers showing that toluene-permeabilized cells carry out production of sorbitol and gluconate at high rates and at greater than 90 % conversion in a batch reactor. These cells immobilized in calcium alginate or in carrageenan had similar production characteristics. Using these immobilized cells in continuous or packed-bed continuous recycle reactors resulted in longer running times, up to 75 days (Rehr et al. 1991). However, the productivity and/or the percent conversion were somewhat lower than for batch operation (Table 1.19). Continuous production of gluconic acid and sorbitol from alternative substrates has been carried out using toluene-permeabilized *Z. mobilis* cells coimmobilized with chitin enzyme complexes in alginate beads (Kim and Kim 1992; Ro and Kim 1991). With immobilized inulase, Jerusalem artichoke inulin provided fructose, and with immobilized invertase, sucrose substituted for both glucose and fructose. The preliminary results are interesting and may provide a framework for further process development using coimmobilization techniques (Table 1.19).

A second approach to efficient synthesis of gluconic acid and sorbitol has been the use of cell-free GFOR from *Z. mobilis*. Using a crude extract of *Z. mobilis* in a continuous ultrafiltration membrane reactor, excellent substrate conversion and enzyme stability were maintained for about 10 days (Silva-Martinez et al. 1998). However, it has been concluded that the strict requirements for enzyme stability would be costly for commercial production and downstream processing, which is a strong argument favoring use of permeable cells (Nidetzky et al. 1997).

Finally, a third approach to achieving high production rates and conversion yields was demonstrated using untreated cells of *Z. mobilis* (Silveira et al. 1999). In batch runs for 8 h with 30 g of pregrown cells/l and glucose plus fructose at 650–750 g/l, yields

reached 91 % for both products with productivities of 48 and 45 g/l-h for gluconic acid and sorbitol, respectively (Table 1.19). Experiments showed that the main reason for the high yields for batch runs with substrate at 650 g/l or greater but not at lower concentrations, such as 300 g/l, was the inhibition of normal metabolism of glucose and gluconates (see Table 1.19). High concentrations of either substrate or products (gluconate and sorbitol) can cause this inhibition effect, which results in preferential conversion of substrates by the glucose-fructose oxidoreductase/glucono- δ -lactonase system (Silveira et al. 1999). The best conversion yield reported for untreated cells is 91 % for gluconic acid and sorbitol, which is lower than 94–98 % for permeabilized *Z. mobilis* with or without immobilization (Table 1.19). However, large-scale permeabilization and immobilization of cells would add to production costs. On the other hand, long runs (up to 75 days) in a two-stage continuous system were achieved with cetyltrimethylammonium bromide (CTAB)-permeable cells immobilized in carrageenan (Rehr et al. 1991). Yet, all of the published continuous processes shown in Table 1.19 operate with low concentrations of products (about 100 g/l), increasing costs for water removal.

Although patents have been issued on various methods for the production of sorbitol and gluconic acid using various *Z. mobilis* cell preparations, clearly, further process development must occur before a viable commercial process will emerge.

Patents

The use of *Gluconobacter (Acetobacter) suboxydans* for production of gluconic acid (by modification of the “quick” vinegar process or by the submerged fermentation process [the Frings process]) is documented in early patents (Currie and Carter 1930; Currie and Finlay 1933). However, because of the

Table 1.19

Experimental production of gluconic acid and sorbitol by *Zymomonas mobilis*

Cell treatment	Reactor	Run time	Substrates glucose and fructose g/l	Production of gluconate sorbitol conversion rate		References
				Rate ^a g/l-h	Percent %	
Toluene permeable	Batch	16 h	600	17.7	95–94	Chun and Rogers (1988)
Toluene permeable in calcium alginate beads	Batch	16 h	600	17.7	94–93	Chun and Rogers (1988)
	Continuous	125 h	200	7.2–7.6	80–85	
CTAB permeable in carrageenan beads	Continuous (two stages)	75 day	200	4.8–6.2	>98	Rehr et al. (1991)
Toluene permeable + inulinase-chitin in calcium alginate beads	Continuous	2 day	200 ^b	19.2–21.3	50	Kim and Kim (1992)
	Recycle-packed bed	10 day	200 ^b	23–26	44	
Toluene permeable + invertase-chitin in calcium alginate beads	Batch	22 h	200 ^c	18	93	Ro and Kim (1991)
	Continuous	2 day	200 ^c	4.5–4.6	70	
	Recycle-packed bed	10 day	200 ^c	5.1–5.2	57	
Untreated cells (30 g/l)	Batch	8 h	300	39–50	40–83	Silveria et al. (1999)
	Batch	8 h	650	48–45	91–91	

Abbreviation: CTAB cetyltrimethylammonium bromide

^aThe rate applies to each product separately

^bJerusalem artichoke inulin (100 g/l) added instead of free fructose

^cSucrose added instead of fructose and glucose

difficulty in controlling the simultaneous appearance of about 10 % ketogluconic acids along with gluconic acids, as well as other serious problems (mentioned in “Scientific Background” and “Areas of Research and Development”), at present, *Gluconobacter* is not considered for development of commercial processes. Thus, *Gluconobacter* spp. do not appear in the patent literature concerning gluconic acid synthesis.

However, numerous patents utilizing *Acetobacter methanolicus* for gluconic acid production have appeared recently. Babel et al. (1986) in Germany have been most active in developing the technology for this process described in more than eight patents. Three patents from this group are listed in Table 1.20. The 1991 patent describes a two-phase process (possibly utilizable for commercial production) culminating in production of a very high yield of gluconic acid (see section “Areas of Research and Development” in this chapter).

There has been a great deal of interest in the possible commercialization of the *Zymomonas mobilis*-catalyzed process for oxidation of glucose to gluconic acid combined with the reduction of fructose to sorbitol. Sorbitol as well as sodium gluconate is used in a variety of industrial applications. The six patents listed in Table 1.20, from 1988 to 1995, reflect examples of processes employing permeabilized cells of *Z. mobilis*.

Because of the characteristics of this system, permeable cells produce high yields at high productivities of both gluconic acid and sorbitol (see sections “Scientific Background” and “Areas of Research and Development” in this chapter). In two of the patents (Rehr et al. 1991; Roehr and Sahn 1995), immobilization techniques are described that increase the total time duration for a stable process. The last patent listed in

Table 1.20 (Silveira et al. 1994) describes the conditions for use of untreated cells of *Z. mobilis* for production of gluconic acid at high yield.

In addition to the patents emphasizing manufacturing methods for bacterial production of gluconic acid, there are many patents on applications of gluconic acid in industry. A brief survey revealed that over the past 10 years, more than 70 US patents appeared for use of gluconic acid and sodium gluconate in pharmaceutical products, food preparations, cleaning of metallic circuits and delicate metal parts, leather treatments, and other products and processes.

Prospects

At present, there are no bacterial conversion processes applied to large-scale commercial production of gluconic acid. Industrial manufacture mainly employs the fungal process with *Aspergillus niger* and *Aureobasidium pullulans* (Roehr et al. 1996; Anastassiadis et al. 1999).

Two bacterial-based processes are under development that may turn out to be competitive in the future. *Acetobacter methanolicus* supersedes *Gluconobacter suboxydans* and related strains. The attributes of this organism that eliminate the disadvantages of *G. suboxydans* are dealt with in “Scientific Background” and “Areas of Research and Development.” A two-phase process has been developed in which *A. methanolicus* cells can be grown on methanol in phase one, and then high glucose concentrations can be converted rapidly to pure gluconic acid during the production phase (Poehland et al. 1993;

Table 1.20

Selected patents for gluconic acid production

Patent number	Year	Inventors and (applicants)	Organism and technology
DD 236,754	1986	Babel et al. (Akad.Wissenschaften)	<i>A. methanolicus</i>
			Batch process, high-yield gluconate
DD 253,836	1988	Babel et al. (Akad.Wissenschaften)	<i>A. methanolicus</i> , <i>Pseudomonas</i> sp.
			Continuous culture
DD 293,135	1991	Babel et al. (Chemie A.-G., Bitterfeld-Wolfen)	<i>A. methanolicus</i>
			Two-phase process: gluconic acid yield 220 g/l
US 47555467	1988	Scopes et al. (Unisearch Ltd., Australia)	<i>Z. mobilis</i>
			Original description, permeabilized cells and cell free
US 5017485	1989	Bringer-Meyer and Sahm (Forschungszentrum, Juelich)	<i>Z. mobilis</i>
			Process: freeze-thaw permeable cells
US 5102795	1992	Rehr and Sahm (Forschungszentrum, Juelich)	<i>Z. mobilis</i>
			Process: surfactant (CTAB) permeable cells
US 5190869	1993	Rehr and Sahm (Forschungszentrum, Juelich)	<i>Z. mobilis</i>
			Process: immobilized, permeable cells
EP 427150B1	1995	Rehr and Sahm (Forschungszentrum, Juelich)	<i>Z. mobilis</i>
			Manufacture: immobilized, permeable cells
BR 9403981	1994	Silveira et al.	<i>Z. mobilis</i>
			Two-phase production: untreated cells

Babel et al. 1991). In experimental reactors with continuous-feed recycle, high yield and high productivity were maintained for 7 days (see section [“Areas of Research and Development”](#) in this chapter).

The *Zymomonas mobilis* production system described above (in section [“Areas of Research and Development”](#)) has the advantage of producing both sodium gluconate and sorbitol under anaerobic conditions. The lack of an aeration requirement during the production process certainly lowers costs when compared to other bioprocesses. Secondly, both sodium gluconate and sorbitol are marketable chemicals with a number of applications. The development of processes using permeabilized cells, untreated cells, or immobilized cells in continuous or fed-batch reactors is still in the experimental stage. The results promise high yields of gluconic acid at high productivities under conditions that may be cost effective and competitive with other processes for gluconic acid manufacture.

Succinic Acid

Introduction

Succinic acid (1,4-butanedioic acid) is a four-carbon acid which occurs as a constituent of almost all plant and animal tissues and microorganisms. It has been of considerable interest in recent years as a renewable feedstock for various petrochemical-based large-volume chemicals, owing to the reactivity of its functional groups. Succinic acid received its name from the Latin name “succinum” meaning “amber,” from which it was first isolated.

National Aniline began production in the United States in 1929 using an electrolytic reduction of maleic anhydride. The fermentative production of succinic acid was studied in Japan in the 1970s utilizing a variety of feedstocks such as paraffins, sucrose, and isopropyl alcohol (Kirk-Othmer 1983).

Succinic acid also is produced as a by-product of adipic acid manufacture and can be sold as a mixture with other organic acids from this process. Annual world production of adipic acid exceeds a billion pounds, and a large amount of by-product succinic acid is obtained. Succinic acid is also sold as a purified product and sells in the range of \$2.–\$2.80/lb, as listed in a Chemical Prices section of the Chemical Marketing Reporter of January 10, 2000.

The fermentation processes of *Escherichia coli* and other enterobacteria have been studied since the time of Pasteur, and much is known about fermentative metabolism and the generation of fermentation end products. In the oxidation of hexose, the fermentation products of *E. coli* are made up of a mixture of ethanol, acetic, formic, lactic, and succinic acids. *Escherichia coli* adjusts the proportion of products to attain redox balance, and generally, succinic acid makes up only 5–10 mol% of the fermentation products (Bock and Sawers 1996). Progress in metabolic engineering has helped raise the interest of various groups in a biological-based industrial process for the overproduction of succinic acid that might compete with petrochemical processes generating comparable four-carbon feedstocks.

Owing to the reactivity of succinic acid, it can be converted to a variety of products, including large-volume chemicals such as 1,4-butanediol and tetrahydrofuran. The use of renewable resources and carbohydrates derived from agricultural materials

such as corn has increased the interest in making intermediates such as succinic acid in an industrial fermentation process. The potential for industrial succinic acid fermentation was discussed as long as 20 years ago by Zeikus (1980). The various biotechnological methods for production and the markets for succinic acid and its various derivatives were reviewed (Zeikus et al. 1999).

Succinic acid was identified as a target chemical by the US Department of Energy Alternative Feedstocks Program. Their initial activity focused on the development of decision-making tools, which led to the commencement of process development research in 1993 for succinic acid (Schilling 1995). A consortium of industry, academic, and government scientists in conjunction with the National Corn Growers put together “Vision 2020,” based on the use of renewable material for chemical production. One of the projects listed in Vision 2020 is a biocatalyst for the production of succinic acid from biomass (Reisch 1999). The future need to replace petrochemically derived chemicals for more green technologies will be a driving force in advancing technology for the production of fermentation-derived chemicals such as succinic acid, as well as push the process development for catalytic conversion of succinic acid to other products.

Scientific Background

Succinate, along with a mixture of other products, is produced during fermentative metabolism by a variety of microorganisms. In *Escherichia coli*, glucose is transported into the cell via the phosphotransferase system and metabolized to pyruvate. The NADH produced during glycolysis must be recycled by conversion of pyruvate to fermentation products so that glycolysis may continue. Pyruvate dehydrogenase, which oxidatively decarboxylates pyruvate, is negatively regulated by NADH and is repressed during fermentative growth. Pyruvate formate lyase, which is functional only under anaerobic conditions, converts pyruvate to acetyl CoA and formate. The cell only turns on one of these enzymes at a time, dependent on the redox status of the cell, allowing the cell to balance NADH during aerobic or anaerobic growth (Bock and Sawers 1996).

During anaerobiosis, the enzyme pyruvate formate lyase is used by *E. coli* to form one molecule of formate and one molecule of acetyl CoA from one molecule of pyruvate. Formate can either be excreted from the cell or decomposed to carbon dioxide and dihydrogen. Two NADH molecules are consumed through the reduction of acetyl CoA to ethanol, which is the most highly reduced major fermentation product of *E. coli*. This conversion occurs through two dehydrogenation reactions catalyzed by alcohol dehydrogenase (Clark 1989).

The production of lactate also uses reducing equivalents, and lactic acid is formed by the enzyme lactate dehydrogenase. Lactate is not essential to balance fermentative growth, and the fermentative NADH-dependent lactate dehydrogenase does not appear to be necessary for anaerobic growth (Mat-Jan et al. 1989).

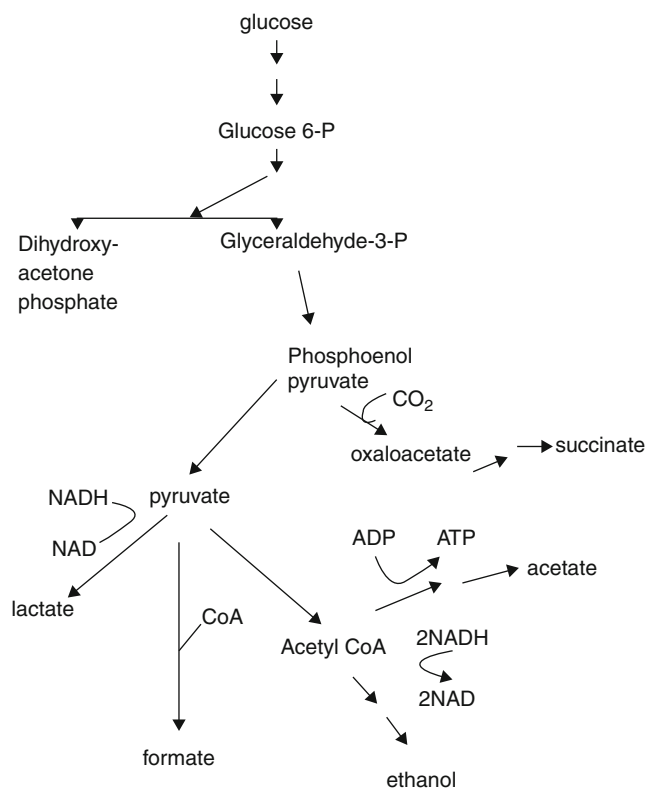

■ Fig. 1.19
Mixed acid pathways of *Escherichia coli*

The production of succinate and the enzymatic reactions of malate dehydrogenase and fumarate reductase use two reducing equivalents per succinate formed. The carboxylation of phosphoenolpyruvate (PEP) is the first step in this reaction, with metabolically generated CO₂ limiting the amount of succinate formed (Bock and Sawers 1996). The reactions below show the mixed acid pathways of *E. coli* (► Fig. 1.19).

Typically, wild-type *E. coli* generates fairly small amounts of succinic acid. Under “Research and Development,” the development of *E. coli* strains that produce large quantities of succinic acid will be discussed in greater detail.

Many succinate-producing bacteria so far described have been isolated from the rumen. Propionic acid, which is used by the animal for biosynthetic precursors and for energy, is produced by the decarboxylation of succinic acid. A review written by Gokarn et al. (1997b) covers in more detail the diversity of microorganisms that can be isolated. The most predominant cellulolytic organism in the rumen is *Fibrobacter succinogenes*. It can use a variety of complex substrates and fixes CO₂ during succinate production. Other succinate producers in the rumen include but are not limited to *Ruminobacter amylophilus* and *Wolinella succinogenes* (Gokarn et al. 1997b).

The productivity of selected rumen bacteria for organic acid production was investigated using a variety of cellulosic substrates. The rumen bacterium *Fibrobacter succinogenes* S85 was shown to produce succinate with a yield of 0.38 g/g of glucose and with an acetate yield of 0.11 g/g of glucose consumed. This organism could use cellobiose to produce

succinic acid but at slightly lower yields. Because succinate has been found to be a major end product of cellulosic substrates (Walseth cellulose, microcrystalline cellulose, pulped paper, and steam-exploded yellow poplar), the use of cellulosic materials for succinic acid production is promising. In contrast, the major end product of *Ruminococcus flavefaciens* on cellobiose, Walseth cellulose, and microcrystalline cellulose was acetate, whereas on pulped paper and steam-exploded yellow poplar, succinate was the major end product. In general, the *Fibrobacter* strain produced more succinate at a higher rate than did the *Ruminococcus* (Gokarn et al. 1997a).

Selenomonas ruminantium, a Gram-negative anaerobe and one of the major species present in the rumen, accumulates succinate as a major end product in the presence of lactate, if malate is added to stimulate lactate uptake. Without malate present, the major end products are acetate and propionate. When succinate reached the concentration of the added malate, malate utilization ended. From a practical standpoint, malate could be added to ruminant diets high in rapidly fermentable carbohydrates. Because high rumen lactate is undesirable, the presence of malate could stimulate lactate utilization (Evans and Martin 1997).

Actinobacillus sp. 130Z, a facultative anaerobic microorganism that was isolated from the rumen, produces high levels of succinate and also accumulates some formate and acetate. This strain was classified as *Actinobacillus succinogenes* sp. nov. (Guettler et al. 1999), and owing to its ability to make high levels of succinate under a variety of conditions, it has been the subject of intensive work as well as patent activity. Studies involving this strain will be discussed in greater detail under “Research and Development.”

Propionibacterium can ferment glucose or glycerol to make fairly high levels of succinic acid (Gottschalk 1985), which is a characteristic component of Swiss-type cheese. High concentrations of CO₂ promote this activity (Wood and Werkman 1938, 1940). *Propionibacterium freudenreichii* subsp. *shermanii* metabolizes aspartate primarily to succinate and ammonia during fermentation of lactate. When fed lactate with sparged CO₂, however, only a small concentration of succinate is formed, and propionate is the main product. This indicates that propionibacteria may use combinations of pathways such as the citrate and transcarboxylase cycles to generate different mixes of end products (Crow 1987).

The production of succinate by *Lactobacillus* has not been widely studied. Kaneuchi et al. (1988) screened 86 isolates of *Lactobacillus* that were isolated from fermented cane molasses using de Man-Rogosa-Sharpe (MRS) broth. Approximately one-third of the strains screened produced succinate, which is of interest owing to the importance of succinic acid as a flavor ingredient in dairy products. They determined that the diammonium citrate in the MRS broth was the precursor to succinate.

The metabolism of carbon dioxide is a critical aspect for the successful production of succinic acid. Three enzymes that have been examined in the overproduction of succinate can fix CO₂. They catalyze the reactions listed in Table 1.21.

Table 1.21

Carbon dioxide utilization reactions involved in succinate production

Substrates	Enzyme	Products	Cell use
Oxalacetate and NTPs	PCK E.C. 4.1.1.49	PEP, NDPs, and CO ₂	Functions during gluconeogenesis to form PEP
PEP, CO ₂ , and water	PPC E.C. 4.1.1.31	OAA and orthophosphate	Functions aerobically to replenish OAA Under fermentative conditions, directs PEP to succinate
Pyruvate, ATP, and HCO ₃ ⁻	PYC E.C. 6.4.1.1	OAA, ADP, and orthophosphate	Can be used to enhance succinate production

Abbreviations: NTP nucleotide triphosphate, PCK phosphoenolpyruvate carboxykinase, NDP nucleotide diphosphate, PEP phosphoenolpyruvate, PPC phosphoenolpyruvate carboxylase, OAA oxalacetic acid or oxalacetate; and PYC pyruvate carboxylase

Actinomyces viscosus, which is associated with periodontal disease and is a succinate producer, incorporates labeled NaHCO₃ into succinate but not lactate. High levels of the enzyme phosphoenolpyruvate (PEP)-carboxykinase were found in cell extracts in this study. This enzyme condenses carbonate and PEP to oxalacetate, which can then be converted to either succinate through malate dehydrogenase and additional metabolic steps or aspartate catalyzed by the enzyme glutamate aspartate aminotransferase (Brown and Breeding 1980).

The microorganism *Anaerobiospirillum succiniciproducens* forms succinate in high amounts and can make greater than 30 g/l (Datta 1992). Several studies have focused on the effect of the supply of CO₂-HCO₃⁻ on succinate production (Samuelov et al. 1991; Nghiem et al. 1997; Lee et al. 1999a). A pH of 6.2 and high CO₂-HCO₃⁻ levels promote succinate as the major product, and the levels of PEP-carboxykinase are high while lactate dehydrogenase and alcohol dehydrogenase levels decrease. Under high CO₂-HCO₃⁻, the growth rate of *A. succiniciproducens* is high and cell yield doubles. Lactate and ethanol are formed as electron sink products if CO₂-HCO₃⁻ are low, and a lower growth rate is observed (Samuelov et al. 1991).

The PEP-carboxykinase (PCK, EC 4.1.1.49) was purified from *A. succiniciproducens*. High levels of this enzyme are made during succinate production, and roughly 10 % of the crude cell protein is PCK. The enzyme has an absolute need for divalent cations, and synergistic effects of various cations were demonstrated. Despite the fact that the fixation of HCO₃⁻ is important in succinate production, the K_m value for HCO₃⁻ is similar to those in other reported enzymes in vertebrates which function in a reverse direction. The authors speculate that high external concentrations of HCO₃⁻ in the environment push the reaction toward oxalacetate (Podkovyrov and Zeikus 1993).

The PCK-encoding gene was cloned from *A. succiniciproducens* and expressed in *E. coli*. Sequence analysis showed

that it is closely related to other PCKs of Gram-negative bacteria and that it is 67.3 % identical to the PCK of *E. coli*. This is surprising in that the PCK gene of *E. coli* is not crucial for succinate production, and one would not expect such high homology. The authors compare kinetic constants with other ATP/ADP-dependent PCKs, although the comparison is not exact because of the differing conditions of analysis. The *A. succiniciproducens* enzyme appears to have a higher V_{\max} for CO₂ fixation than those of *E. coli* and *Trypanosoma cruzi* and a higher K_m s for PEP and ADP. The authors conclude that sequence and structural features are probably not responsible for the differing activities of the various PCKs (Laivenieks et al. 1997).

The PCK of *A. succiniciproducens* requires the nucleoside triphosphate ADP, and a pyruvate kinase-like activity of this enzyme was identified. In gluconeogenesis, PCK catalyzes the irreversible decarboxylation of oxalacetate, and in *A. succiniciproducens*, AMP was shown to activate this oxalacetate decarboxylase reaction (Jabalquinto et al. 1999).

The enzyme PEP-carboxykinase also appears to play an important role in other high-succinate producers besides *A. succiniciproducens*. The availability of CO₂ in the medium affects succinate production, and a direct relationship between CO₂ added and succinate production is observed. In a comprehensive comparison between enzyme activities of *Actinobacillus* sp. 130Z and *E. coli* K-12 grown anaerobically, the specific activity of the *Actinobacillus* PCK was shown to be a thousand-fold higher than that of *E. coli*. This is in contrast to the many other enzymes that showed similar activity and indicates that PEP-carboxykinase is produced constitutively in this microorganism (Van der Werf et al. 1997).

In contrast to the previous two examples on the importance of PCK in succinate production by *A. succiniciproducens* and *Actinobacillus*, overexpression of PCK in *E. coli* had no effect. This result is surprising in that the *E. coli* PCK enzyme has similar if not better kinetic characteristics than the *A. succiniciproducens* enzyme, and why this enzyme does not play an important role in *E. coli* succinate overproduction is uncertain. In *E. coli*, a different CO₂-fixing enzyme appears to play a role, as overexpression of PEP-carboxylase, produced during growth on glycolytic substrates, increased succinate production from 3.27 to 4.44 g/l and did not alter the distribution of fermentation products (Millard et al. 1996).

A similar pathway for the formation of succinate in both *Actinobacillus* sp. 130Z and *A. succiniciproducens* has been proposed. The formation of oxalacetate from PEP via CO₂ fixation is the first key step. The enzymes malate dehydrogenase, fumarase, and fumarate reductase, all enzymes of the tricarboxylic acid (TCA) cycle, work in a reductive fashion toward succinate (Van der Werf et al. 1997; Samuelov et al. 1991). The reactions catalyzed are as follows:

1. Phosphoenolpyruvate + CO₂ + NDP → Oxaloacetate + NTP
2. Oxaloacetate + NADH → L-Malate + NAD
3. L-Malate → Fumarate + H₂O
4. Fumarate → Succinate

Enzymes utilized are (1) phosphoenolpyruvate carboxykinase, (2) malate dehydrogenase, (3) fumarase, and (4) fumarate reductase.

The drive toward succinate production is influenced by environmental factors that can be controlled in a fermentation process. This aspect will be discussed under “Areas of Research and Development.”

Commercial Applications

Succinic acid is sold into four major existing markets. The largest is as a surfactant and foaming agent. The other uses are as a chelator in electroplating, an acidulant and flavoring agent in food, and in the production of health-related agents. The estimated market size for these four areas is more than \$400 million per year (Zeikus et al. 1999).

The promise of large-scale low-cost fermentations from renewable resources, especially corn, has spurred interest in the United States to develop chemical production for large-volume chemicals using bio-based processes. Succinic acid can be converted by hydrogenation to 1,4-butanediol, which has a world market in excess of 500,000 metric tons. Butanediol is used to produce polybutylene terephthalate (PBT) resins that have desirable mechanical and thermal properties and are a high-performance version of polyethylene terephthalate resins (PET). Also, 1,4-butanediol is a precursor of tetrahydrofuran, which can be polymerized to polytetrahydrofuran (PTHF). Gamma butyrolactone (GBL) can also be derived from 1,4-butanediol, and much of GBL is used to manufacture the solvent *N*-methyl-2-pyrrolidone (Szmant 1989).

Butanediol is manufactured primarily through a process called “the Reppe process,” which reacts acetylene and formaldehyde at high pressure. Alternative chemical technologies such as a maleic anhydride process and a process using ester hydrogenation technology have come on line (Tullo 1999). The raw materials used in the chemical process are large volume and low cost. For example, maleic anhydride sells in the range of about \$0.50/lb. This means that a fermentation process must be very efficient with low raw material costs to be able to compete with a chemical-based process.

A methodology was described to assess the feasibility of success in making commodity chemicals from renewable resources. The methodology uses a five-step process in the assessment. The first step is portfolio selection, and some of the key selection criteria are high theoretical yields from substrate, high market interest, and volume. The second phase involves initial economic screening and uses an economic criterion called “the Fraction of Revenue for Feedstock” (FRF). In this calculation, the cost of the feedstock is divided by the value of all the products, and the products that show the most promise are those where the fraction is smallest. This value takes into account the yields of the products derived from the various feedstock components. The third phase is a comparative analysis of bioprocessing routes that uses a raw material cost ratio, which

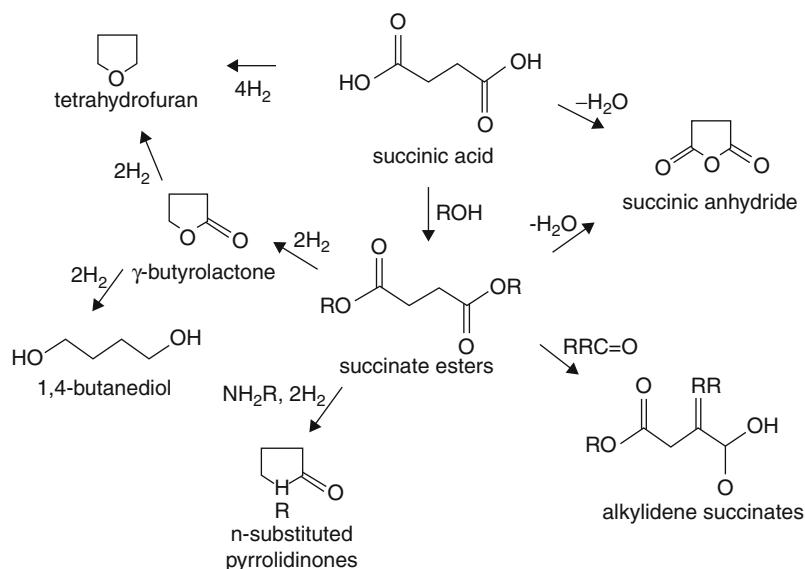

Fig. 1.20

Summary of catalytic conversion pathways and potential products derived from succinic acid (From Varadarajan and Miller (1999), with permission)

in essence compares the raw material costs for a bioprocess versus those for the petrochemical route. Phase four is a qualitative analysis, and phase five is a detailed economic analysis requiring a significant effort to classify and do economic assessment of the process technologies. A number of products in an initial portfolio were assessed, then narrowed down to a shorter list which includes acetic acid, 2,3-butanediol, malic acid, and propylene glycol to name a few. Succinic acid was identified as a potential near-term opportunity because it had one of the best FRFs and raw material cost ratios (Landucci et al. 1994). Despite the attractiveness of succinic acid, at this writing, an industrial-scale bioprocess has not been attained. However, improvements in the process technology and strains (as evidenced in the patent literature) indicate the potential for a succinic acid bioprocess in the near future.

The other important aspect of the development of the succinic acid market is the chemical conversion of succinic acid to other products. Selective and low-cost catalyst development is needed to enable lower-cost economics. The chemistry of succinic acid catalysis has been reviewed by Varadarajan and Miller (1999), and the summary of the various derived products that follow is from that work. Succinic acid can be readily converted into alkyl esters that have uses as industrial solvents and paint removers. Succinic acid, its anhydride or its esters, can be hydrogenated to the product family of 1,4-butanediol; however, this conversion has not been as well studied as the hydrogenation of maleic acid or anhydride. A third important product family that can be derived from ammonium succinate, succinimide, or succinic acid is based on 2-pyrrolidinones. They are used for polyvinylpyrrolidone (PVP) production, which has an estimated minimum market value of \$150 million per year. Other uses for 2-pyrrolidinones include solvents and plasticizers. The commercial production depends upon petrochemical-based

materials. A summary of the potential products that can be derived from succinic acid is presented in Fig. 1.20 (Varadarajan and Miller 1999).

The major economic issue in whether succinic acid can compete is the low starting cost of petrochemical raw materials. The target cost for succinic acid from a bioprocess is estimated to be around \$0.25/lb for a large-scale plant (Zeikus et al. 1999; Varadarajan and Miller 1999). This target cost is necessary to compete with low-cost petrochemical raw materials.

Despite the major interest in the large-volume uses of succinic acid, other new specialty markets of interest should not be ignored. A succinate-based animal feed additive from whey fermentation has been described (Samuelov et al. 1999). The entire fermentation is dried down to a product, which is about one-third succinate, and also contains protein, other organic acids, and salts. Succinate is desirable as a feed additive as it is rapidly converted to propionate, which in the rumen improves efficiency and contributes to the overall health of the animal.

Ethylenediamine-*N,N'*-disuccinic (EDDS) acid is a chelator that can be used in detergents and is a potential replacement for ethylenediaminetetraacetic acid (EDTA) (Lin et al. 1996). It is also biodegradable, and various optical isomers have different susceptibilities to biodegradation (Takahashi et al. 1997). Succinic acid also can be used in the manufacture of biodegradable plastic. A novel biodegradable plastic, called "Bionolle," invented in the early 1990s is based on poly(butylene succinate), poly(butylene adipate succinate), or poly(ethylene succinate). These plastics have been produced on a pilot plant scale and show good processability. They can be processed with conventional equipment and can be made into products such as bottles and foam (Fujimaki 1998). A copolymer can be made with succinic acid and 1,4-butanediol (Takiyama and Fujimaki 1994). Bionolle has been shown to be biodegradable in a variety of environments,

including activated sludges, soils, and compost. Many strains were isolated that can degrade Bionolle (Nishioka et al. 1994).

A novel food use of succinic acid was also identified which is attractive for consumers who would like to reduce their salt consumption. A salt substitute comprised of succinic acid, chloride ion, and lysine has been patented (Turk 1993). The use of organic acids as environmentally friendly promotants of plant growth is an attractive use that bears further exploration. As an example, succinate addition can improve the growth of plants such as potato (Andrianova et al. 1998). Clearly, the growth of succinic acid use as an intermediate in a wide variety of both specialty and commodity markets shows considerable promise for the future viability of a succinic acid bioprocess.

Research and Development

Although at this time, there is no commercial-scale succinic acid bioprocess, interest remains high, as shown by the activity in the patent and scientific literature. Three different organisms which all show promise have been the focus of the strain improvement research and process development.

Strain Improvement

Actinobacillus 130Z was isolated from bovine rumen at the Michigan Biotechnology Institute. It was later identified as *Actinobacillus succinogenes* sp. nov., and it is a facultatively anaerobic Gram-negative rod. It is one of the most promising succinic acid producers studied to date, as it can use a variety of sugars and produce greater than 70 g of succinic acid/l (Guettler et al. 1999). It was isolated in enrichment vials containing an ionophore and fumarate. An atmosphere enriched in carbon dioxide is necessary for rapid fermentative growth (Guettler et al. 1998). The enzyme activities of *Actinobacillus* 130Z and *E. coli* K-12 were compared under the same growth conditions. As described earlier, *Actinobacillus* had increased levels of the CO₂-fixing enzyme PEP-carboxykinase (which appears to be made constitutively) as well as high levels of L-malate dehydrogenase, fumarase, and fumarate reductase, which are all involved in the conversion of PEP to succinate. *Actinobacillus* also had high malic enzyme and oxalacetate decarboxylase activities in contrast to *E. coli* (Van der Werf et al. 1997).

Improvements to *Actinobacillus* were obtained by growing the organism on a source of fermentable carbon as well as sodium monofluoroacetate and by selecting for fluoroacetate-resistant mutants. These mutants give higher succinate production, reduced amounts of acetate and formate and can produce more than 100 g of succinic acid/l in 48 h with a yield as high as 97 wt.% on glucose. Presumably, carbon flow has been diverted from acetate and formate into the production of succinate (Guettler et al. 1996a).

Anaerobiospirillum succiniciproducens is another high succinate producer that has been the focus of several patents and process development. One patent describes a method for

making mutants of *A. succiniciproducens* similar to the method for deriving mutants of succinate-producing *Actinobacillus*. The technique involves the selection of fluoroacetate mutants of *A. succiniciproducens*. The mutant isolated produces less acetate, and in the fermentation, the succinate/acetate ratio is as high as 85:1. The lowering of acetate in the fermentation is important in that it is a problem contaminant in the electro dialysis separation process for purifying succinic acid from the fermentation. Reduced toxicity and inhibition of the fermentation by acetate are other advantages of this mutation. It appears that in the mutant, termed "FA-10," pyruvate production has increased while acetate production decreases and succinate levels stay about the same (Guettler and Jain 1996).

A metabolic engineering approach toward improvement of *Anaerobiospirillum succiniciproducens* was attempted by cloning and overproducing the PEP-carboxykinase gene. This gene, as described previously, catalyzes the addition of carbon dioxide to PEP to form oxalacetate and can work physiologically in both directions (Laivenieks et al. 1997). This is the first *A. succiniciproducens* gene to be cloned and sequenced. Codon usage is similar to *E. coli* except for a few amino acids, and the putative promoter region also shows many similarities. The gene was overexpressed successfully in *E. coli* so that further kinetic studies could be done. The authors did not look at the effects of overexpression in *A. succiniciproducens*, but now that work has commenced on identifying key genes in this organism, it is likely that future work will focus on improvements of the organism for succinic acid production.

As mentioned earlier, *E. coli* produces succinate but usually at very low levels. One strategy employed by various groups has been the overexpression in *E. coli* of various enzymes that direct carbon flow to succinate. As mentioned previously, uptake and utilization of carbon dioxide is necessary for high yields of substrate, and attention has been focused on increasing the level of CO₂-fixing enzymes. Phosphoenolpyruvate carboxylase, which functions aerobically to produce oxalacetate and fermentatively to direct PEP to succinic acid, was overexpressed in *E. coli*, and a significant increase in succinate production was seen. The authors cited an average increase from 3.27 to 4.44 g of succinic acid/l formed (Millard et al. 1996). When PEP-carboxykinase, which catalyzes the phosphorylation and decarboxylation of oxalacetate to form PEP, was overexpressed in *E. coli*, the distribution of fermentation products remained the same, and the amount of succinic acid did not increase. That the overexpression of PEP-carboxykinase did not improve succinate production in *E. coli* is rather surprising, as *A. succiniciproducens* uses a PEP-carboxykinase in its succinate production. The authors speculate that some as yet unknown regulatory control may prevent the *E. coli* PEP-carboxykinase from operating in the reverse direction (Millard et al. 1996).

As *E. coli* does not contain pyruvate carboxylase, a heterologous gene from *Rhizobium etli* was introduced into *E. coli*. A 50 % increase in succinate levels and about a 20 % decrease in lactate concentration were observed. Glucose uptake was not affected, and thus, this approach may have advantages over increased PEP-carboxylase, which may have undesirable

effects in reduction of glucose membrane transport and the phosphotransferase system (Gokarn et al. 1998). The *R. etli* pyruvate carboxylase requires acetyl CoA for activation and is inhibited by aspartate and may be expressed at low levels under typical conditions for succinate production. Use of an alternate pyruvate carboxylase that is not affected by either acetyl CoA or aspartate such as the *pyc* gene from *Pseudomonas fluorescens* was proposed (Gokarn et al. 1999).

Much of the focus on succinate production has been with the use of glucose as a substrate. However, fumaric acid has also been explored as a possible substrate. Fumarate reductase was overexpressed in *E. coli* strains that were fed fumaric acid. High cell density and the presence of glucose were required for increased succinate yield and rate of production. The recombinant strains with enhanced fumarate reductase levels had a succinate molar yield of 120 % after 4 days. Without glucose present, however, mostly malate was produced (Goldberg et al. 1983). Multicopy fumarate reductase genes were also expressed in *E. coli* fed with varying concentrations of glucose and fumaric acid. Fumaric acid at 90 g/l inhibited succinate production, whereas succinic acid production was rapid in the range of 50–64 g/l. Like the work mentioned in the above paragraph, the authors found that glucose addition in the presence of fumaric acid was necessary and as little as 5 g of glucose/l could substantially increase the production. The authors speculated that glucose was used as the hydrogen donor for the conversion of fumaric to succinic acid (Wang et al. 1998).

Another overexpression strategy was tried with the NAD^+ -dependent malic enzyme of *E. coli*. Thermodynamically, the reduction of pyruvate to malate is favored, but in nature this reaction does not occur. A double mutant of *E. coli*, NZN111, which is blocked in both pyruvate formate lyase (*pfl*) and lactate dehydrogenase (*ldh*), was used as the host. It is unable to grow anaerobically because its pyruvate metabolism is blocked by the fermentation end products acetate, formate, ethanol, and lactic acid. The mutant NZN111 with multiple copies of malic enzyme accumulated succinic acid as a major end product only when the cells were switched to anaerobic metabolism gradually by metabolic depletion of oxygen in a sealed tube (Clark et al. 1988). Mutant strains blocked in either *pfl* or *ldh* did not alter their distribution of fermentation products when overexpressing malic enzyme.

The importance of reducing power was shown for NZN111, as addition of hydrogen gas to the media increased the apparent yield of succinate from 0.65 g per g of glucose to 1.2 g per g of glucose. Although succinate production increased with expression of malic enzyme, NZN111 fermented glucose very slowly, making it less attractive for commercial production (Stols and Donnelly 1997). Overexpression of a heterologous malic enzyme from *Ascaris suum* yielded similar results (Stols et al. 1997).

A novel succinate pathway in *E. coli* was discovered in the NZN111 mutant. Using site-directed mutagenesis, mutations were made in malate dehydrogenase, which catalyzes the interconversion of malate and oxalacetate. These mutant malate

dehydrogenases had activity toward pyruvate instead of oxalacetate and provided a low-lactate-dehydrogenase-like activity. Fermentative growth appeared to be limited by the low-lactate-dehydrogenase-like activity, so directed evolution was used to select a variant enzyme with improved lactate dehydrogenase activity. After several rounds of subculturing, a mutant termed “AFP111” (named after the Alternate Feedstocks Program of the US Department of Energy) was isolated based on accelerated glucose catabolism. From 1 mole of glucose, this mutant yields 1 mole of succinic acid, 0.5 moles of acetic acid, and about 0.5 moles of ethanol. This is the first example of an *E. coli* strain that produces succinic acid as its major fermentation product. Donnelly et al. (1998a) proposed that glucose forms two PEPs, one of which is converted to succinate and the other to ethanol and acetate (► Fig. 1.21).

The new strain AFP111 appears to be attractive for commercial use, owing to the lack of strict anaerobic culturing conditions needed, the use of low-cost growth medium, and its ability to grow on xylose and other biomass-derived sugars. This strain was shown to produce up to 45 g of succinic acid/l (Donnelly et al. 1998b).

A similar approach in a different laboratory toward constructing strains of *E. coli* was done by creating a double mutant with mutations in the phosphotransacetylase gene (*pta*) and the *ldh* gene. The *pta* gene catalyzes the conversion of acetyl

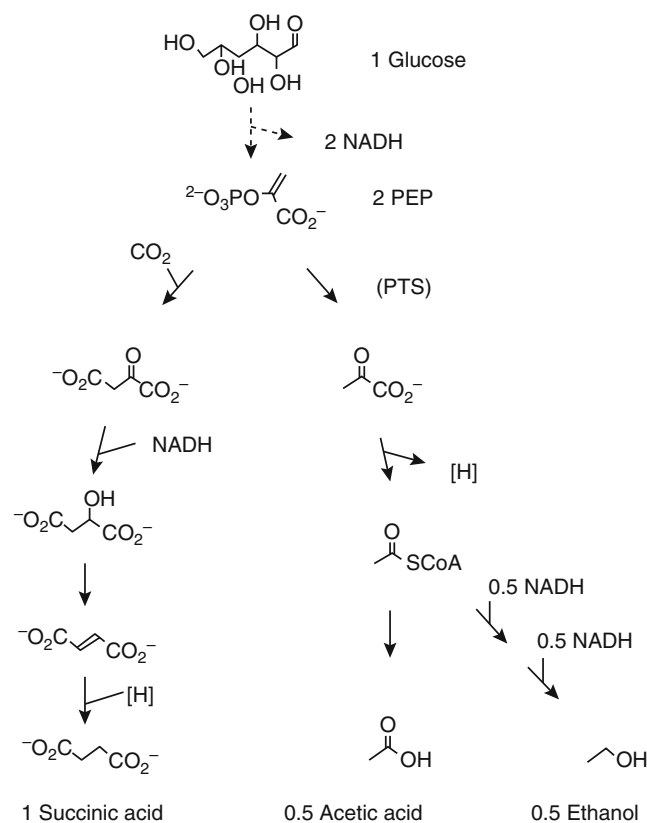

► Fig. 1.21 Pathway for succinic acid production from glucose by *E. coli* strain AFP111 (From Donnelly et al. (1998a), with permission)

CoA to acetyl phosphate, and a mutation in this gene blocks the fermentative pathway to acetate. When grown under anaerobic conditions, this mutant produced about four times more succinate than the wild type produced as well as significant pyruvate levels. Lactate production was not detected, and acetate production was considerably reduced, which may be of interest in light of downstream separation processes (Pan et al. 1999).

Process Development

There is at this writing no commercial-scale process for the production of succinic acid. There has been activity over the last several years, which is primarily found in the patent literature, to improve the fermentation as well as the downstream process. A great deal of effort was initially spent on *Anaerobiospirillum succiniciproducens*, as this was the first organism observed which could produce succinic acid in levels high enough to envision a commercial process.

Anaerobiospirillum succiniciproducens is a strict anaerobe and grows at an optimal temperature of 39 °C. A typical fermentation medium contains dextrose, peptone, yeast extract, and salts. The optimal pH range for this organism was determined to be between 5.8 and 6.4. This organism can produce approximately 30 g of succinate/l from a starting glucose concentration of 50 g/l. Calcium hydroxide is added to produce a calcium succinate product, which can be precipitated from the broth (Datta 1992).

Low-cost commercial ingredients can be used as part of an *A. succiniciproducens* fermentation, using dextrose and corn steep solids from a corn wet-milling plant. The pH adjustment can be done using high-purity industrial grade lime. High initial concentrations of dextrose were inhibitory unless tryptophan was added at 25 ppm. A continuous multistage fermentation with simultaneous precipitation of calcium succinate was shown to be feasible, and a productivity of 2.0 g/l-h was observed. Another cost-saving measure, the use of spent filtrate from a previous fermentation, was shown to increase fermentation productivity when added to a fermentation up to a level of 50 % (Datta et al. 1992).

The effect of medium components on the production of succinic acid by *A. succiniciproducens* was systematically studied. Sodium ion is essential for glucose transport, and an optimal level of 4 g of NaCl/l was determined. In contrast, magnesium ion did not appear to affect growth or succinic acid production. A variety of complex nitrogen sources were also assessed, and a mixture of polypeptone, yeast extract, soytone, and peptone gave better results than any of these ingredients used alone (Lee et al. 1999).

A large batch was run in an 80-l fermenter. A high succinate yield of 87 wt.% of added substrate carbon was obtained in a fermentation time of 22.5 h (Datta et al. 1992). Biotin was shown to be an important microingredient. At 50 mg of added biotin/l, an increase in glucose consumption was seen, and both succinic and acetic acid were increased by 17 % and 30 %, respectively. Biotin can be found in corn steep liquor; however,

the heat treatment needed to sterilize corn steep liquor may inactivate the biotin (Nghiem et al. 1996).

One of the most important factors in the success of succinate fermentation by *A. succiniciproducens* is the addition of carbon dioxide in some form to the media. Using CO₂ supplied as solid magnesium carbonate at pH 6.2 (a molar ratio of CO₂-HCO₃⁻ to glucose of 1.0–0.5), 90 % of the glucose was consumed, and 65 % of the carbon was converted to succinate. When the molar ratio of CO₂-HCO₃⁻ to glucose was lowered to 0.065, only 45–60 % of the glucose was consumed and 8 % of the carbon was converted into cell mass. The molar yield of ATP also drops significantly in the lower CO₂-HCO₃⁻ concentrations. At high CO₂-HCO₃⁻ levels, PEP-carboxykinase is present in high amounts (Samuelov et al. 1991).

Some uncertainty exists in how the CO₂ should be optimally supplied to the fermenter. Nghiem et al. (1997) found that supply of CO₂ via 1.5 M Na₂CO₃ was adequate and that sparging CO₂ gas into the fermenter at 0.025 l/min lowered the rate and yield of succinate production, whereas acetate production was not affected. This is in contrast to the work of Datta (1992), who found that the fermentation did not start as rapidly without a CO₂ sparge. In Datta's patent, increasing the partial pressure of CO₂ produced better results, and at 100 % CO₂, which is a partial pressure of 1 atm, the fermentation was finished in 21 h, in contrast to a fermentation time of 42 h at 30 % CO₂ (Datta 1992). Possibly, CO₂ solubility is a factor in the different results, as at pH 6.5, CO₂ is three times more soluble than at pH 6.2 (Jones and Greenfield 1982).

In comparison to glucose, succinic acid is a highly reduced fermentation product. The effect of supplying hydrogen gas with CO₂ was evaluated. The greatest effect appeared to be on the rate of succinate production. At an optimal H₂/CO₂ ratio of 5:95, the rate of succinate production is 1.8 g/l-h. Varying glucose concentrations also were studied, as higher substrate concentration would help reduce fermentation costs. The optimal glucose concentration of 20–40 g/l is in the range of previously observed values, and at the higher glucose concentration of 80 g/l, rate and yield of succinate were lowered (Lee et al. 1999a).

Not as much work on the process development of an *Actinobacillus* 130Z fermentation has been described. This situation will likely change, as this organism shows very promising attributes for an industrial process. *Actinobacillus* 130Z is not a strict anaerobe and does not require the careful culture conditions as does *A. succiniciproducens*. *Actinobacillus* 130Z is tolerant to very high succinate concentrations and will initiate growth in up to 130 g of magnesium succinate/l. In contrast, *A. succiniciproducens* will not initiate growth in media with 20 g of disodium succinate/l. *Actinobacillus* 130Z prefers to obtain its nitrogen from organic sources, and succinate production is increased by eliminating ammonium sulfate. It is more tolerant than *A. succiniciproducens* to pH and can produce succinic acid at high amounts in the pH range of 6.2–7.2. Control of pH can be done with either sodium carbonate or sodium hydroxide. *Actinobacillus* 130Z also can use a wide variety of substrates, including arabinose, fructose, xylose, sucrose, and glucose (Guettler et al. 1996b).

Actinobacillus 130Z requires the addition of carbon dioxide to the medium, and about 0.3 atm partial pressure is used. Because it is not sensitive to oxygen, pretreatment of the media to remove oxygen need not be done. It is able to use low-cost media ingredients such as corn steep liquor from a corn wet-milling plant. Compared to *A. succiniciproducens*, it demonstrates unusually high tolerance to substrate concentrations and can produce succinic acid at glucose levels as high as 150 g/l (Guettler et al. 1998). This ability to tolerate high glucose concentration is desirable in that less fermentation capital equipment needs to be employed, reducing the overall cost of the process.

Actinobacillus 130Z produces the highest reported amounts of succinic acid. In serum vials, it can produce nearly 80 g/l and in a fermenter produced more than 60 g/l in less than 36 h. With continued incubation, it was able to produce 75–79 g of succinate/l (Guettler et al. 1998).

A novel approach toward supplying reducing power to *Actinobacillus succinogenes* was attempted using electrically reduced neutral red. An electrochemical bioreactor with anode and cathode compartments separated by a cation-selective membrane was constructed. The redox dye mediates electron transfer from the electrode into cellular metabolism. Electrically reduced neutral red enhanced the growth of *Actinobacillus* along with glucose consumption and succinate and ethanol production, whereas formate and acetate production was decreased. Neutral red is not toxic to the cells and can bind to the membrane, providing electrons to fumarate reductase. Neutral red appears to replace quinones in the fumarate reductase complex of *Actinobacillus* (Park and Zeikus 1999). The approach of using electrical reducing power may have applications in other industrial fermentations besides succinic acid production.

The other succinate process that has been the focus of process development in the patent literature uses *E. coli* AFP111. A two-stage process in which the organism is grown aerobically to generate biomass and switched to anaerobic growth to turn on succinate production has been described. Hydrogen gas can be used as a reductant by the microorganism. The authors report that succinic acid concentration can reach 45 g/l in a 100 % carbon dioxide atmosphere and the weight yield of succinate to glucose can reach 99 % (Nghiem et al. 1999).

The typical medium described for *E. coli* consists of tryptone, yeast extract, glucose, and salts. A fed-batch fermentation can be run using a glucose and corn steep feed mixture, and during the fermentation, the glucose concentration is maintained at less than 1 g/l. *Escherichia coli* could produce succinic acid in the pH range of 6.2–7.4, but the optimal pH appears to be close to 6.6. The microorganism produced high levels of succinic acid in a corn steep liquor medium, with a fermentation time of approximately 99 h (Nghiem et al. 1999).

There appears to be at present three candidates for the industrial production of succinic acid. Each has advantages and disadvantages for commercial production. A simple comparison of the three strains can be made based on yield and fermentation time and is shown in ► Table 1.22.

► Table 1.22

Summary of high succinic acid producers

Organism	Succinic acid titer (g/l)	Fermentation time (h)
<i>Actinobacillus succinogenes</i> 130Z	~100	36–40
<i>Anaerobiospirillum succiniciproducens</i>	~35	36–40
<i>Escherichia coli</i> AFP111	~45	99

As yet, all examples in the literature have been laboratory or pilot scale, and it is unknown what challenges will occur when these fermentations are scaled up to greater volumes.

The cost of recovery of succinic acid will be of prime importance in determining whether a cost-effective process will allow succinate-derived chemicals to compete with petrochemicals. Most succinate fermentations need to be run at or near a neutral pH and require the addition of a salt to maintain pH. Removal of the salt to achieve the isolation of the desired acid is one of the challenges of developing a low-cost separation process. Various approaches toward the recovery of organic acids have been tried, but it is beyond the scope of this chapter to review organic acid separation technology. Some work has focused specifically on succinic acid and that is what will be covered here.

As mentioned previously, succinic acid can be precipitated from fermentation broth with calcium hydroxide. A calcium succinate cake can be recovered from the fermentation broth. Acidification of this cake with sulfuric acid yields succinic acid and calcium sulfate solids (gypsum). After this stage, the succinic acid contains many impurities and can be further purified by ion exchange on a strongly acidic cation exchange resin that removes calcium and other cations. Use of a weakly basic anion exchange resin in the next step will remove sulfate and other anionic impurities (Datta et al. 1992). One drawback of the calcium precipitation process is that it produces gypsum as a by-product.

Another approach to purify succinic acid is the use of electro dialysis technology. One patent describes an integrated process in which the fermentation broth goes through an electro dialysis membrane to concentrate the succinate salt, and then that feed subsequently goes through a water-splitting electro dialysis membrane to form a base and the succinic acid product. The base is recycled to the fermenters for pH control, and the succinic acid is further purified with ion-exchange chromatography to remove residual sodium ion, amino acids, and sulfate ions. The other major fermentation product, acetate, is retained through this process with the succinic acid (Glassner and Datta 1992).

Water-splitting electro dialysis can be improved by using a supersaturated solution of the free acid. Sodium acetate inhibits crystallization of succinic acid, but free acetic acid, which is produced by water-splitting electro dialysis, promotes crystallization of succinic acid (Berglund et al. 1991).

Another separation strategy uses the formation of diammonium succinate, where the ammonium ion is used to control the pH in the fermentation. The diammonium succinate can be concentrated and reacted with a sulfate ion at low pH to yield ammonium sulfate and succinic acid. Succinic acid has very low solubility in aqueous solutions with a pH below 2 and can be crystallized. The succinic acid can be purified with methanol, and the ammonium sulfate is thermally cracked into ammonia and ammonium bisulfate. The ammonia can be fed back into the fermenter, and the ammonium bisulfate can be recycled for use in succinic acid crystallization (Berglund et al. 1999).

It is likely that process development for succinic acid will continue to be explored. Desirable features of an economic process would include a high-yielding fermentation that can tolerate process conditions, low-cost substrate, and an integrated separation process that can recover and purify succinic acid at low cost.

Patents and Regulatory Issues

There are a number of patents on the microorganisms, fermentation process, and downstream separation of succinic acid. In addition, there are patents that cover the further conversion of succinate to other products and many patents on the competitive chemical processes that make large-volume chemicals such as 1,4-butanediol. A useful summary of the downstream chemical conversion patents appears in Varadarajan and Miller (1999). While patents have been referenced throughout this section on succinic acid, it is of interest to summarize succinic acid fermentation, strain development, and downstream separation patents here.

Prospects for Succinic Acid Production

At this writing, there is no commercial large-scale process for succinic acid production by fermentation (▶ Table 1.23). To make large-scale commodity chemicals derived from succinic acid, the price of the acid needs to be in the range of less than 50 cents per pound. This is due to the competition with petrochemically derived raw materials that are also sold in this price range or at an even lower price.

The specialty markets for succinic acid such as surfactants, food uses, and health-related ingredients may benefit from having a “natural” succinic acid produced by fermentation. As the prices of these materials are much higher than commodity chemicals, a fermentation-based process may be able to make product at a cost competitive for these markets (Tsao et al. 1999).

What are some of the technology developments needed to make the production of succinic acid by fermentation an attractive economic option? The theoretical yield of succinic acid is greater than 1 kg of succinic acid per kilogram of glucose. To achieve this theoretical yield, efficient delivery of CO₂ for fixation by the organism is necessary. Also, strains that can use H₂ to supply reducing equivalents may yield economic improvements in the fermentation process.

Strain development is well under way with organisms that can produce as much as 100 g of succinic acid/l. Certain strains appear to be robust enough to flourish under conditions of high substrate, high final product concentrations, and they do not require special handling, such as total removal of oxygen. Some organisms also can grow on a wide variety of carbon sources and sugars. This opens up the opportunity to use low-cost cellulosic-based materials such as agricultural waste products as a very cheap source of starting raw materials.

■ Table 1.23

Patents for succinic acid production

Assignee	Patent number	Year	Organism	Technology
Applied carbochemicals	US 5958744	1999	Not applicable	Downstream purification
University of Georgia research	PCT WO99/53035	1999	<i>E. coli</i>	Strain improvement
Foundation Lockheed Martin energy	US 5869301	1999	<i>E. coli</i>	Fermentation
Research Corp. Korea Institute of Science and Technology	PCT WO99/06532	1999	<i>E. coli</i>	Strain improvement
University of Chicago	US 5770435	1998	<i>E. coli</i>	Strain improvement
Michigan Biotechnology Institute	US 5723322	1998	<i>Bacterium 130Z (Actinobacillus)</i>	Fermentation
Michigan Biotechnology Institute	US 5521075	1996	<i>Anaerobiospirillum succiniciproducens</i>	Fermentation
Michigan Biotechnology Institute	US 5504004	1996	<i>Bacterium 130Z (Actinobacillus)</i>	Strain
Michigan Biotechnology Institute	US 5573931	1996	<i>Bacterium 130Z (Actinobacillus)</i>	Strain improvement Fermentation
None cited	US 5143833	1992	<i>Anaerobiospirillum succiniciproducens</i>	Downstream purification
None cited	US 5168055	1992	<i>Anaerobiospirillum succiniciproducens</i>	Downstream purification
None cited	US 5143834	1992	<i>Anaerobiospirillum succiniciproducens</i>	Downstream purification

The costs of separation of succinic acid will be a critical component in economical production of this acid. As acids are neutralized in the fermentation to maintain an appropriate pH for the microorganism, the salts formed must eventually be removed and can be a waste generation problem. Promising separation technology is the use of liquid-liquid extraction and water-splitting electro dialysis. Key also to lowering separation costs is the development of microorganisms that produce as few by-products as possible which need to be removed from the final product stream.

The other key issue for production of large-volume chemicals is the technology needed to further convert succinic acid to other products such as 1,4-butanediol. This process technology must be very competitive with other processes that start with low-cost petrochemical feedstocks. One potential avenue to reducing costs may be the use of crude fermentation broth that is chemically converted and then purified in some further downstream process.

The use of fermentation-derived succinic acid is one of the most promising bio-based processes for large-scale commodity chemical production and may be competitive to petrochemical processes at some future date. The development of this process at a large scale can open up new markets for agriculturally derived raw materials and be a “green” chemical based on renewable resources.

Polyhydroxyalkanoic Acids

Introduction

Polyhydroxyalkanoic acids (PHAs) are polyester storage material synthesized by a wide range of microorganisms when their growth in medium containing excess carbon and energy sources is restricted by the lack of an essential nutrient. The PHAs also are formed as reduced end products in some organisms when there is a deficiency in O₂ as the terminal electron acceptor for the cell to achieve a redox balance in metabolism. Some PHAs have physical properties comparable to thermoplastics produced from petrochemicals. The best known PHAs are the homopolymer polyhydroxybutyrate and the copolymer poly (3-hydroxybutyrate-co-3-hydroxyvalerate) or Biopol, which was produced by the bacterium *Ralstonia eutropha* (formerly *Alcaligenes eutrophus*) and saw applications in a range of consumer products (Steinbüchel 1996). The process for Biopol production was developed by Zeneca BioProducts (formerly ICI of the United Kingdom) and later sold to Monsanto of the United States (Lee 1996b; Steinbüchel 1996). The commercial production of Biopol ended in 1998 because of high production cost. However, active research is under way worldwide to improve the physicochemical properties of PHAs as well as the economics of producing better PHAs. Also, novel applications for PHAs have been proposed for the future when PHAs with new properties are synthesized, and the commercial importance of their chiral monomers is recognized.

One salient property of PHAs is their biodegradability. Until the introduction of man-made plastics, manufactured goods using materials derived from plants and animals were biodegradable and completely recyclable in the environment. Although plastics have dramatically improved human life, the durability of discarded plastic wares in the environment has created a serious waste-management problem. Use of the biodegradable PHAs as a substitute for the petroleum-based plastics can help preserve the quality of life as well as the natural environment, if PHAs can be produced economically.

Despite their undesirable durability after disposal, plastics are hard to replace because of their low cost and versatility. Plasticwares are inexpensive mainly because they can be mass-produced from historically inexpensive raw materials. The thermoplastics have allowed the use of machines and procedures to mass-produce a very wide range of consumer products. It is thus obvious that if a low-cost, environmentally degradable thermoplastic is available, the new material will allow the continued production of inexpensive but nonpolluting plasticwares for the future generations. This need is the driving force for active research on PHAs.

During the past decade, books (Doi 1990; Doi and Fukuda 1994; Mobley 1994), a special issue of FEMS Microbiology Reviews (Vol. 103, pp. 91–364, 1992), and many reviews (Anderson and Dawes 1990; Aminabhavi et al. 1990; Steinbüchel 1991, 1996; Poirier et al. 1995; Lee 1996a, b, 1997; Ishizaki et al. 1997; Steinbüchel and Fuchtenbusch 1998; Madison and Huisman 1999) were devoted to PHAs. The following publications may be consulted for a more in-depth coverage of the microbiology of PHA-producing organisms (Steinbüchel 1991), the biosynthesis and degradation of PHAs (Anderson and Dawes 1990; Steinbüchel 1991, 1996; Hocking and Marchessault 1994; Madison and Huisman 1999), genes for PHA formation (Madison and Huisman 1999), the physicochemical properties of PHAs (Hocking and Marchessault 1994; Steinbüchel 1996), analytical methods for PHAs (Anderson and Dawes 1990; Hocking and Marchessault 1994; Steinbüchel 1996), commercial production and economic considerations (Doi 1990; Byrom 1992; Hrabak 1992; Hocking and Marchessault 1994; Lee and Chang 1995a; Poirier et al. 1995; Lee 1996a, b; Steinbüchel 1996), metabolic engineering of bacteria and plants for PHA production (Madison and Huisman 1999; Poirier et al. 1995), and patents for PHA production and application (Steinbüchel 1996).

Scientific Background

History

Among the naturally occurring PHAs, the best known is the polyhydroxybutyric acid, which is commonly abbreviated as “poly(3HB)” or “PHB.” The discovery of poly(3HB) in bacteria is attributed to Maurice Lemoigne of the Pasteur Institute, who in 1925 reported the presence of 3-hydroxybutyric acid in the

autolysate of *Bacillus megaterium* (Lemoigne 1925) and in 1926 reported the isolation from *B. megaterium* of a polyester with the empirical formula of $(C_4H_6O_2)_n$ and identified the material as poly-3-hydroxybutyrate (Lemoigne 1926). In a note published in 1943, Lemoigne indicated that the occurrence of a PHB-like material in *Azotobacter* was reported by M. W. Beijerinck as early as in 1901, but it had been overlooked until it was reported by Stapp in 1918 (Lemoigne and Girard 1943).

Schlegel et al. (1961) presented a landmark study on the formation and utilization of poly(3HB) by three strains of hydrogen-oxidizing or knallgas bacteria belonging to the genus "*Hydrogenomonas*," which has since been renamed as "*Alcaligenes eutrophus*" and as "*Ralstonia eutropha*" (Yabuuchi et al. 1995). Electron micrographs of thin sections of *Hydrogenomonas* H16 showed that the inclusions of poly(3HB) could accumulate to occupy the bulk of the intracellular space, and the amount of poly(3HB) reached 65 % of the dry weight of these cells. Poly(3HB) purified from *Azotobacter chroococcum*, *Bacillus megaterium*, and *Hydrogenomonas* (strains H1, H16, and H20) by these workers had the expected chemical composition and identical infrared spectra. The melting points ranged from 150 °C to 155 °C (*A. chroococcum*) to 168–173 °C (*B. megaterium*), and the variation was attributed to different degrees of polymerization, an explanation that was validated by later studies. The earlier workers found that poly(3HB) is soluble in chloroform but not in ethyl ether, which provides an effective method for the purification of poly(3HB) from lyophilized cells.

Chemical Structure

PHAs are hydrophobic linear polyesters with the general structure of



For biosynthetic PHAs, n can vary from 1 (poly-3-hydroxyalkanoate) to 4 (poly-6-hydroxyalkanoate). The hydroxyl-substituted carbon atom (the chiral center) of the acid monomer and the corresponding carbon atom in the PHAs are in the R configuration. Over 120 different acid monomers have been found as constituents of PHAs (Anonymous 1999). Furthermore, the PHAs may be homo- or heteropolymers. The R groups or side chains of the acid monomers may be aliphatic or aromatic, saturated or unsaturated, linear or branched, and halogenated or epoxidized. These side chains also can be modified chemically (Madison and Huisman 1999). A simpler side chain can range from a hydrogen atom to an aliphatic chain of up to 13 carbon atoms, i.e., these PHAs are the condensation product of monomers ranging from 3-hydroxypropionic acid to 3-hydroxyhexadecanoic acid (Steinbüchel 1996; Madison and Huisman 1999). Because of the diversity of the side chains in the PHAs, the physicochemical properties of PHAs vary significantly to allow a broad range of possible applications.

Physicochemical Properties

For practical purposes, the most important properties of PHAs are the thermoplasticity and elasticity. The PHAs are thermoplastic materials, meaning that they are resins that become highly viscous and moldable at temperatures close to or above the melting point. The properties of poly(3HB) are often compared to those of polypropylene (Hocking and Marchessault 1994), as both polymers have similar melting points, degrees of crystallinity, and glass-transition temperatures. However, poly(3HB) is both stiffer and more brittle than polypropylene, resulting from the presence of large crystals in poly(3HB). Poly(3HB) has a lower solvent resistance but a much higher resistance to ultraviolet weathering than polypropylene. The solubility of poly(3HB) in a wide range of solvents has been determined (Steinbüchel 1996). The crystal structure of PHAs has been discussed in some detail by Hocking and Marchessault (1994).

The material properties of poly(3HB) are greatly improved by the incorporation of 3-hydroxyvaleric acid to form the poly(3-hydroxybutyrate-co-3-hydroxyvalerate) or poly(3HB-co-3HV) copolymer (Hocking and Marchessault 1994). By manipulating the ratio of the two monomers in the copolymer, a range of physical properties may be obtained. Because organisms other than *R. eutropha* have PHA polymerases that can incorporate a variety of 3-hydroxyalkanoic acids into the copolymer, application of genetic engineering should allow the production of PHAs with superior physical properties as well as biodegradability.

Poly(3HB) and poly(3HB-co-3HV) are piezoelectric materials, whereas the piezoelectric properties of other PHAs have not been investigated (Steinbüchel 1996). The piezoelectric materials produce electric charges on parts of their surface when mechanical pressure is applied to the crystalline material, and an electric current will result from the charges if the crystal is short circuited. Conversely, application of a voltage between certain faces of the material produces a mechanical distortion (a deformation) of the material. Piezoelectric materials have important applications in electromechanical transducers, such as microphones. In medicine, chemically synthesized piezoelectric polymers such as polyvinylidene fluoride stimulated bone growth. The piezoelectric property of poly(3HB) may be important for some medical applications (Steinbüchel 1996).

PHA-Producing Organisms

Most genera of bacteria and members of the halophilic Halobacteriaceae of the Archaea synthesize PHAs. A comprehensive listing of PHA-producing organisms can be found in Steinbüchel (1991), which illustrates the wide distribution of the capacity to synthesize PHAs among microbes and also suggests the physiological importance of PHAs to the producing organisms. ▶ *Table 1.24*, adapted from Lee (1996b) and Steinbüchel and Fuchtenbusch (1998) and also with newer findings, lists the salient features of representative natural and recombinant strains of PHA-producing bacteria. It should be

Table 1.24

Production of polyhydroxyalkanoic acid by natural and recombinant strains of bacteria

Bacterium	PHA	Carbon source	Cell density (g/l)	PHA content (%)	References
<i>Alcaligenes latus</i>	Poly(3HB)	Sucrose	112	88	Wang and Lee (1997a, b)
<i>Azotobacter vinelandii</i>	Poly(3HB)	Glucose	40.1	79.8	Page and Cornish (1993)
<i>Chromobacterium violaceum</i>	Poly(3HV)	Valeric acid	41	65–70	Steinbüchel and Schmack (1995)
<i>Escherichia coli</i> , recombinant	Poly(3HB)	Glucose	117	76	Kim et al. (1992)
<i>Escherichia coli</i> , recombinant	Poly(3HB)	Whey	194	87	Ahn et al. (2001)
<i>Escherichia coli</i> , recombinant	Poly(3HB-co-3HV)	Glucose + propionic acid	203.1	78.2	Choi and Lee (1999b)
<i>Klebsiella aerogenes</i> , recombinant	Poly(3HB)	Molasses	37	65	Zhang et al. (1994)
<i>Methylobacterium organophilum</i>	Poly(3HB)	Methanol	250	52	Kim et al. (1996)
<i>Protomonas extorquens</i>	Poly(3HB)	Methanol	233	64	Suzuki et al. (1986)
<i>Pseudomonas oleovorans</i>	Poly(3HHx-co-3HO)	Octane	40	35–40	De Koning et al. (1997)
<i>Pseudomonas oleovorans</i>	Poly(3HHx-co-3HO-co-3HD)	Glucanoic acid + octanoic acid	54	66	Kim et al. (1997)
<i>Pseudomonas putida</i>	Poly(3HHx-co-3HO-co-3HD-co-3HDD-co-3HTD)	Oleic acid	93	45	Weusthuis et al. (1997)
<i>Pseudomonas putida</i> , recombinant	Poly(3HB-co-3HV-co-4HV-co-3HHx-co-3HO)	Octanoic acid + levulinic acid	20	43	Steinbüchel and Gorenflo (1997)
<i>Ralstonia eutropha</i>	Poly(3HB)	Glucose	164	74	Kim et al. (1994)
<i>Ralstonia eutropha</i>	Poly(3HB)	Carbon dioxide	91.3	67.8	Tanaka et al. (1995)
<i>Ralstonia eutropha</i>	Poly(3HB-co-3HV)	Glucose + propionic acid	>100	70–80	Byrom (1992)

Abbreviations: PHA polyhydroxyalkanoic acid; 3HB 3-hydroxybutyric acid; 3HD 3-hydroxydecanoic acid; 3HDD 3-hydroxydodecanoic acid; 3HTD 3-hydroxytetradecanoic acid; 3HHx 3-hydroxyhexanoic acid; 3HV 3-hydroxyvaleric acid; 3HO 3-hydroxyoctanoic acid; and 4HV 4-hydroxyvaleric acid

noted that the name of the PHA-producing organisms can be a potential source of confusion because bacterial taxonomy is a work in progress. Both the name and the taxonomic position of an organism are subject to change. For example, the name of the best-known PHA-producing organism has been changed from *Hydrogenomonas* H16 to *Alcaligenes eutrophus* to *Ralstonia eutropha*. A literature search based on any one of these names will miss a large amount of pertinent information.

Besides heterotrophic bacteria and Archaea, the phototrophic bacteria, including phototrophic purple bacteria and cyanobacteria, are also PHA producers. A study of 15 strains of nonsulfur purple bacteria and 15 strains of sulfur purple bacteria showed that all of them produced poly(3HB) when the growth medium was supplemented with acetate (Liebergesell et al. 1991). When supplemented with propionate, valerate, heptanoate, or octanoate, most of the strains produced poly(3HB), and the nonsulfur purple bacteria produced poly(3HB-co-3HV) copolymers even with acetate as the carbon

source. The production of PHA by cyanobacteria was first reported by Carr (1966), and the list of PHA-producing cyanobacteria includes species of *Anabaena*, *Aphanothece*, *Chloroglea*, *Gloeocapsa*, *Oscillatoria*, *Spirulina*, *Synechococcus*, and *Synechocystis* (Hein et al. 1998; Taroncher-Oldenburg et al. 2000). Production of PHAs by cyanobacteria for commercial purposes has attracted attention lately because the phototrophic organisms use CO₂ instead of the more expensive organic compounds as the carbon source.

Besides the PHA-producing organisms available in pure cultures, various environmental samples, such as the sludge from sewage digesters, contain characteristic PHAs that have not been observed in pure cultures (Steinbüchel 1996). The biosynthetic capabilities of these not yet characterized PHA-producing organisms may greatly expand the possibility of producing novel chiral monomers for the chemical and pharmaceutical industries (see section “Production of Chiral Monomers” in this chapter).

Physiological Functions of PHAs

The bulk of PHAs is synthesized as a storage material for carbon and energy or as the result of the cell's need to use an alternative route to dispose of excess reducing power under O₂ deficiency. These PHAs occur as granules or inclusion bodies in the cell and contain non-PHA substances for the assembly of such structures (Steinbüchel 1996). In addition, PHAs also are produced by other organisms, including *Escherichia coli*, but to a much lower level and in complexes with calcium and polyphosphates. It has been proposed that complexes of poly(3HB), calcium ions, and polyphosphates form a helical tubular structure which is located in the cytoplasmic membrane of *E. coli* (Reusch and Sadoff 1988). Because transformation efficiency correlated with the concentration of poly(3HB) in the membrane, it was speculated that the tubular structure in the membrane might play a role in conferring a cell's competency in taking up extracellular DNA (Reusch 1992). However, this model has been challenged (Muller and Seebach 1993).

Unbound or complexes of PHAs also occur in eukaryotic organisms, including baker's yeast and tissues of various plants and animals, but the concentrations were one or two orders of magnitude lower than those in competent cells of *E. coli* (Reusch 1992; Reusch and Sparrow 1992). The function of PHA in eukaryotes is not known (Steinbüchel 1996).

Biosynthesis

The biosynthesis of PHAs involves three key reactions:

1. The condensation of two acyl CoA molecules to form a 3-ketoacyl-CoA, with the release of a CoA
2. The reduction of 3-ketoacyl-CoA to the chiral (R)-(-)-hydroxyacyl-CoA monomer
3. The polymerization of the monomers to PHA

Two nonchiral compounds, acetyl CoA and its condensation product acetoacetyl CoA, are the most common metabolic intermediates serving as the precursors for the synthesis of poly(3HB) or other PHAs. Stereospecific reductases and hydratases convert acetoacetyl CoA into chiral (R)-(-)-3-hydroxybutyric acid, which is polymerized into poly(3HB). From different starting substrates, different pathways are used for the synthesis of acetyl CoA, and different organisms may use distinct pathways to form (R)-(-)-3-hydroxybutyric acid (Steinbüchel 1996). Besides acetyl CoA, longer-chain acyl CoAs are synthesized via specialized reactions when appropriate substrates are available. The actual composition of the PHA formed thus depends on the types of monomers that are present in the cell, which in turn depends on the carbon substrates that are provided in the growth medium. This flexibility allows one to direct an organism to synthesize PHA copolymers with tailored monomer compositions that confer desirable properties.

Among the different pathways for PHA biosynthesis, the pathways for the formation of poly(3HB) are the best

characterized. In *R. eutropha*, the synthesis of poly(3HB) from acetyl CoA requires only the three reactions described above, whereas in *Rhodospirillum rubrum*, two additional reactions are required to convert (S)-(+)-3-hydroxybutyryl-CoA to (R)-(-)-3-hydroxybutyryl-CoA to be used by the poly(3HB) polymerase (Steinbüchel 1996). Formation of the copolymer poly(3-hydroxybutyrate-co-3-hydroxyvalerate) or poly(3HB-co-3HV) in *R. eutropha* requires the condensation of acetyl CoA and propionyl-CoA to form 3-ketovaleryl-CoA; a 3-ketothiolase different from that catalyzing the formation of acetoacetyl CoA is required for this reaction (Slater et al. 1998). In *Pseudomonas oleovorans* and *Pseudomonas aeruginosa*, which synthesize PHAs from medium-chain-length monomers (more than five carbon atoms), a multitude of reactions are involved in converting acetyl CoA to (R)-(-)-3-hydroxyacyl-CoA or (R)-(-)-3-hydroxyacyl-ACP (acyl carrier protein) to serve as the substrate for the PHA polymerase (Steinbüchel 1996).

The enzymes and their structural genes for the three key reactions for the synthesis of PHAs of short-chain-length monomers (three to five carbon atoms) have been extensively studied, and their salient features are summarized below.

3- OR β -Ketothiolase. The thiolase for PHA synthesis is known as the biosynthetic thiolase because its physiological function is in the direction of combining two acyl CoA molecules into a 3-ketoacyl-CoA molecule, instead of the thiolytic reaction occurring in β -oxidation of saturated fatty acids. *Ralstonia eutropha* has three or more biosynthetic 3-ketothiolases (enzyme A, enzyme B, and BktC) that differ in their substrate specificity and hence their role in PHA production (Haywood et al. 1988; Slater et al. 1998). The activity of enzyme A (encoded by the *phbA* gene) with 3-ketovaleryl-CoA (3-ketopentanoyl-CoA) is 3 % of that with acetoacetyl CoA and is hence responsible for the formation of poly(3HB). The activities of enzyme B (encoded by the *bktB* gene) with 3-ketoacyl-CoAs having 5–10 carbon atoms are 10–30 % of that with acetoacetyl CoA (Haywood et al. 1988). Enzyme B or BktB is responsible for the formation of the 3HV monomer for the production of the copolymer poly(3HB-co-3HV) (Slater et al. 1998). Slater et al. (1998) reported the presence of another 3-ketothiolase (BktC) that may serve as a secondary route toward 3HV production. The BktC enzyme was detected in both the wild type and a double mutant for enzymes A and B.

The structural genes for 3-ketothiolase have been cloned and sequenced from over a dozen of PHA-producing bacteria, and they have been designated as either “*pha*” (for PHA metabolism) or “*phb*” (for poly[3HB] or PHB metabolism) genes (Madison and Huisman 1999). The *phbA* gene encodes the 3-ketothiolase (enzyme A) for the synthesis of acetoacetyl CoA, and the gene was first cloned from *Zoogloea ramigera* (Peoples and Sinskey 1987) and then from *R. eutropha* (Peoples and Sinskey 1989) and a number of other organisms. In *R. eutropha*, the *bktB* gene encodes the second 3-ketothiolase, also known as “enzyme B” or “BktB” (Slater et al. 1998). The *pha* genes are for the synthesis of medium-chain-length PHAs (PHAs composed of 3-hydroxy fatty acids with 6–16 carbon atoms), and at present there are fewer characterized *pha* than *phb* genes. Although the *pha* and

phb genes were initially found to form operons, it now appears that these genes are not necessarily clustered and that the gene organization may vary from one species to another as these organisms have diverse PHA biosynthetic pathways (Madison and Huisman 1999).

3- or β -Ketoacyl-CoA Reductase. The 3-ketoacyl-CoA reductase catalyzes a crucial reaction for the synthesis of PHA; it introduces the correct chirality into 3-hydroxyacyl-CoA to provide the substrate for PHA polymerase, and by consuming 3-ketoacyl-CoA, the reductase and PHA polymerase together make the 3-ketothiolase-catalyzed condensation reaction energetically favorable. Also, NADPH is the predominant coenzyme and reductant for the characterized 3-ketoacyl-CoA reductase. The availability of reducing power in the form of NADPH is thus considered the driving force for PHA formation (Madison and Huisman 1999).

In *R. eutropha*, acetoacetyl-CoA reductase is encoded by the *phbB* gene (Peoples and Sinskey 1987). The *phb* biosynthesis operon in *R. eutropha* consists of the *phbC* (encoding PHA polymerase), *phbA* (encoding 3-ketothiolase), and *phbB* genes in that order. The three enzymes encoded by the *R. eutropha phb* operon are sufficient for the synthesis of PHAs consisting of short-chain-length monomers (3-hydroxyacyl-CoAs with 3–5 carbon atoms).

PHA Polymerase or Synthase. The key enzyme for PHA biosynthesis is the PHA polymerase, also known as the “PHA synthase,” which catalyzes the polymerization of the (*R*)-(-)-hydroxyacyl-CoA monomers to PHAs. To date, the structural genes for PHA polymerase have been cloned from about 30 bacteria. Based on the subunit composition and the substrate range, the PHA polymerases can be divided into three classes: the class I represented by the enzyme of *R. eutropha*, the class II represented by the enzyme of *Pseudomonas oleovorans*, and the class III represented by the enzyme of *Chromatium vinosum*. The class III PHA polymerases are two-component enzymes, encoded by the genes *phaC* and *phaE*, whereas the other PHA polymerases contain one polypeptide encoded by the *phaC* gene. A comparison of the PHA polymerases may be found in Hein et al. (1998) and Madison and Huisman (1999). The class III PHA polymerases may be further divided into two classes, with the class IV represented by the enzyme from *Thiocapsa pfennigii*, which has a broader substrate range (including CoA thioesters of medium-chain-length hydroxyalkanoic acids) than that of *C. vinosum* (Steinbüchel 1996).

The genes for the two-component PHA polymerase of the cyanobacteria *Synechocystis* sp. strain PCC6803 were cloned and characterized (Hein et al. 1998). Because the genome of this organism has been sequenced, it also has allowed the identification of the genes for the PHA-specific 3-ketothiolase and acetoacetyl-CoA reductase in this cyanobacterium (Taroncher-Oldenburg et al. 2000). Transformation of *E. coli* or a PHA-negative mutant of *R. eutropha* with the PHA biosynthesis genes of *Synechocystis* sp. strain PCC6803 conferred the PHA-synthesizing ability to *E. coli* or *R. eutropha* and also allowed

the positive identification of genes and enzymes for the complete PHA biosynthesis pathway of cyanobacteria.

In addition to the genes encoding the enzymes for the three key reactions of PHA synthesis, other identified *pha* genes play roles in the assembly of the PHA granules or in the conversion of metabolic intermediates leading to PHA synthesis. The *phaF* and *phaI* genes of *Pseudomonas oleovorans* encode major PHA granule-binding proteins (Prieto et al. 1999a). The *phaD* gene of *P. oleovorans* encodes a protein that is not a major granule-associated protein; however, the PhaD protein seems to be required for the presence of the PhaI protein (Klinke et al. 2000). Inactivation of the *phaD* gene caused the disappearance of the PhaI protein, a decrease in the PHA granule size, and an increase in the number of granules in the cell. The *phaG* gene encodes the 3-hydroxydecanoyl-ACP (acyl-carrier protein):CoA transacylase in *Pseudomonas putida*, which provides a metabolic link between the de novo biosynthesis of fatty acids and the biosynthesis of PHA consisting of C₆–C₁₄ monomers (Rehm et al. 1998). Transfer of the *P. putida phaG* gene and the *P. aeruginosa phaC1* gene (encoding PHA polymerase) into *Pseudomonas fragi* (a PHA nonproducer) enables the transformant to synthesize PHAs containing primarily C₁₀ monomers derived from gluconate, an unrelated carbon source (Fiedler et al. 2000).

Degradation

Degradation of PHA is important for two practical reasons: it affects the yield and quality of PHA during commercial production, and it affects the disposal of consumer goods manufactured from PHA. Degradation of PHA can occur as a nonbiological process or as the result of extracellular and intracellular activities of PHA-degrading enzymes. This topic has been reviewed by Dawes and Senior (1973), Anderson and Dawes (1990), Hocking and Marchessault (1994), Steinbüchel (1996), and Jendrossek et al. (1996).

Nonbiological degradation of PHA is the result of spontaneous hydrolysis or thermal decomposition. Spontaneous hydrolysis occurs at a slow rate but is enhanced by acidic and alkaline conditions. There is an apparent initial increase in crystallinity, when the extent of hydrolysis increases, which is followed by a decrease in crystallinity and an elevated rate of hydrolysis. Thermal decomposition of many PHAs occurs at temperatures not far above the melting point, which necessitates the use of additives in the PHAs to minimize structural damages during the molding processes. If the molded articles will be subjected to prolonged heat exposure, cautionary measures are also necessary. The mechanisms of hydrolytic and thermal degradation have been reviewed by Hocking and Marchessault (1994).

Biodegradation in the environment normally proceeds via surface attack by bacteria, fungi, and algae. Because the degradation process initiates on the surface, the rate of biodegradation depends in part on the ease of surface colonization. Therefore, the surface area and texture as well as the thickness of the article

are important factors in affecting the rate of degradation. The supply of nutrients such as nitrogen and phosphorus as well as oxygen is the other environmental factor that controls microbial growth and hence the rate of biodegradation. Among the different environments, the anaerobic sewage allows the fastest rate of degradation, which is followed by well-watered soil, seawater sediments, aerobic sewage, the rumen of cattle, and seawater. A 1-mm thick molding resin test bar breaks down completely within 6 weeks in anaerobic sewage; this time increases to 60–70 weeks in aerobic sewage and soil at 25 °C and to 350 weeks in seawater at 15 °C. Packaging films 50 µm in thickness totally degrade in 1–2 weeks in anaerobic sewage, 7 weeks in aerobic sewage, 10 weeks in soil at 25 °C, and 15 weeks in seawater at 15 °C. A molded shampoo bottle made of poly(3HB-co-3HV) is almost completely degraded after 15 weeks in a compost pile; significant degradation in a landfill occurs over 40 weeks. These results clearly indicate that the disposal of PHA-based consumer products must be properly managed or the time required for biodegradation may take years in some environments. The original studies yielding these results are referenced in the review by Hocking and Marchessault (1994).

Biodegradation in the environment involves extracellular enzymes secreted by microorganisms, and these enzymes have been collectively described as PHA depolymerases. Of the characterized depolymerases, most of them hydrolyze the PHA polymer into dimers, and the dimers are further hydrolyzed to the monomers by an extracellular or intracellular dimer hydrolase. The depolymerase from a *Comamonas* species, however, appears to hydrolyze poly(3HB) directly to 3-hydroxybutyrate (reviewed by Hocking and Marchessault 1994). Not surprisingly, the degree of crystallinity significantly affects the rate of PHA degradation, and it was concluded that poly(3HB) molecules in the amorphous state are more easily hydrolyzed than poly(3HB) in the crystalline state (reviewed by Steinbüchel 1996).

Extracellular PHA or oligomer depolymerases have been isolated from *Alcaligenes faecalis*, as reviewed by Anderson and Dawes (1990); *Pseudomonas lemoignei* (reviewed by Steinbüchel 1996); and other organisms (reviewed by Steinbüchel 1996). From each organism, the distinct depolymerases exhibit different substrate specificity and kinetic properties, and depending on the depolymerase, the dimeric product may be released from either the free hydroxy terminus or the carboxyl-terminus of PHA or oligomers derived from the polymer. Structural genes for these depolymerases have been cloned and characterized. The deduced amino acid sequences of the depolymerases all contain the motif Gly-Leu-Ser-Xaa-Gly at the N-terminus, which corresponds to the Alipase box found in lipases and esterases (Jendrossek et al. 1995), and they also share a triad consisting of serine (from the Alipase box) plus histidine and aspartate, which corresponds to the active site triad of bacterial lipases.

Intracellular degradation of PHAs in the PHA-producing organisms is a physiological process, and this activity can potentially influence the quality and yield of PHAs to be isolated

for commercial applications. Research on this aspect of PHA metabolism has been reviewed by Anderson and Dawes (1990), Hocking and Marchessault (1994), and Steinbüchel (1996), but less is understood about this process than extracellular biodegradation. In *R. eutropha*, biosynthesis and degradation of poly(3HB) have been reported to occur simultaneously, even when poly(3HB) is being accumulated, hence causing a constant turnover of poly(3HB) within the inclusion bodies (Doi et al. 1990). It was also reported that high molecular weight poly(3HB) was produced in the first stage of accumulation (up to 10 h), and the molecular weight slowly decreased during the remaining period of accumulation (Kawaguchi and Doi 1992).

Degradation of the native granules of poly(3HB) seems to involve different enzymes and accessory proteins in different organisms. In *R. rubrum* and *Azotobacter beijerinckii*, the native granules are self-hydrolyzing, whereas degradation of native granules isolated from *Bacillus megaterium* required a heat-labile factor associated with the granules together with three soluble components—a heat-stable protein activator, a heat-labile depolymerase, and a hydrolase—prepared from the extracts of *R. rubrum* (reviewed by Anderson and Dawes 1990; Hocking and Marchessault 1994). Purified poly(3HB) or denatured granules did not serve as substrates. In *R. eutropha*, 3HB monomers are the direct product of depolymerase action, whereas in other organisms, the depolymerases degrade poly(3HB) to dimers, and a dimer hydrolase completes the degradation to monomers. The 3HB monomers may be metabolized to acetyl CoA through reactions formally resembling the reversal of the biosynthetic reactions.

Metabolic Engineering

Metabolic engineering of PHAs was reviewed by Madison and Huisman (1999), and literature in this area is expanding at a fast rate because the use of molecular biology tools has been successful in improving the properties of organisms ranging from bacteria to higher plants for PHA production. The need to have better organisms for the production of PHAs became obvious after the commercial introduction of Biopol, which was produced by mutant strains of glucose-grown *R. eutropha* converting glucose and propionate into poly(3HB-co-3HV). *Ralstonia eutropha* can accumulate PHA to a high level in the cell; however, the bacterium has a relatively low optimal growth temperature and long generation time, the substrates are expensive, the cell is relatively hard to lyse, and it has enzymes for PHA degradation. Also, the genetics of *R. eutropha* were not well understood, which hindered genetic manipulations of this natural producer. Nevertheless, the *lac* and *gal* operons of *E. coli* were successfully transferred into *R. eutropha* and expressed, hence enabling *R. eutropha* to use lactose (the major carbohydrate in whey) as a less expensive carbon source (Pries et al. 1990). When the PHA biosynthesis genes of *R. eutropha* were cloned and expressed in *E. coli*, it effectively started metabolic engineering of *E. coli* for PHA production (Schubert et al. 1988). Compared with *R. eutropha*,

the recombinant *E. coli* strains have the desired properties of having a faster growth rate, ease of cell lysis when the cell is loaded with PHA, tolerance to propionic acid, and the feasibility to perform a variety of genetic manipulations.

Initially, the effect of added copies of PHA biosynthesis genes on PHA production was examined in several natural and nonnatural PHA-producing bacteria. The studies found no dramatic increases in PHA production by introducing additional copies of *phb* or *pha* genes (reviewed by Madison and Huisman 1999). The results are not surprising in light of the finding that other factors, such as the supply of NADPH (Lee et al. 1996), limit PHA production. Supplementation of amino acids or oleate, both of which require substantial reducing power for their synthesis, increased poly(3HB) production (Lee et al. 1995).

Different strains of *E. coli*, including K12, B, W, XL1-Blue, DH5 α , HB101, JM 109, and C600, were similarly transformed with the stable high-copy-number plasmid pSYL105 containing the PHA biosynthesis genes of *R. eutropha*, and poly(3HB) production by the transformants was compared (Lee and Chang 1995b). The rate of poly(3HB) synthesis, the extent of poly(3HB) accumulation, and the yield of poly(3HB) from glucose varied considerably from one strain to another. Strains XL1-Blue and B (harboring the plasmid) produced poly(3HB) at the highest rate. A poly(3HB) concentration of 81 g/l could be obtained in 41 h from a pH-stat fed-batch culture of *E. coli* (pSYL105).

Following the transfer of the PHA biosynthesis genes from *R. eutropha* into *E. coli*, the recombinant *E. coli* strains were further altered by the introduction of other genes. The transfer of the *prpE* gene, encoding the propionyl-CoA synthetase, from *Salmonella enterica* serovar *typhimurium* enabled the strain to produce poly(3HP-co-3HB) (Valentin et al. 2000a). Inactivation of the ketoacyl-CoA degradation step of the β -oxidation enabled the strain to produce PHAs having different monomer compositions when grown on different alkanates (Ren et al. 2000). Introduction of genes coding for the enzymes for the conversion of glutamate or 4-aminobutyrate to 4-hydroxybutyryl-CoA (see section 2 “Production of PHA Copolymers” in this chapter) enabled the recombinant strain to produce poly(3HB-co-4HB) (Valentin et al. 2000b).

When the PHA polymerase genes of *Thiocapsa pfennigii* and the genes for butyrate kinase and phosphotransbutyrylase of *Clostridium acetobutylicum* were transferred into *E. coli*, the recombinant strain produced copolymers and terpolymers of 3HB, 4HB, and 4HV when provided with the corresponding hydroxy fatty acids (Liu and Steinbüchel 2000b). Introduction of the PHA polymerase gene (*phaC1*) from *Pseudomonas oleovorans* into *E. coli* with a stable regulated expression system allowed the recombinant *E. coli* to produce chiral medium-chain-length PHAs (Prieto et al. 1999b). Other examples of expressing the PHA polymerase gene of pseudomonads in *E. coli* to produce medium-chain-length PHAs can be found in the review by Madison and Huisman (1999).

Chromobacterium violaceum produces poly(3HB) or poly(3HB-co-3HV) when grown on a fatty acid carbon source. When the PHA polymerase gene of *C. violaceum* was transferred

into *E. coli* or *Pseudomonas putida* and expressed, the recombinants did not accumulate a significant level of PHA. However, similarly transformed *Klebsiella aerogenes* and *R. eutropha* accumulated poly(3HB), poly(3-HB-co-3HV), and poly(3-HB-co-3hydroxyhexanoate). Transfer of the *P. putida phaG* gene (encoding a transacylase) and the *P. aeruginosa phaC1* gene (encoding PHA polymerase) into *P. fragi* enables the recombinant strain to produce PHAs consisting of medium-chain-length monomers (Fiedler et al. 2000). These results illustrate the relationship between the availability of different metabolic intermediates as precursors for PHA synthesis and the composition of the PHA formed. They also show that a PHA polymerase can react with different hydroxyacyl-CoAs within a certain size range, and when metabolic engineering alters the pattern of hydroxyacyl-CoAs present in a cell, the composition of PHAs formed may be similarly altered.

When PHA-producing cells are lysed for processing, the released chromosomal DNA causes a dramatic increase in viscosity. The high viscosity of cell lysate hinders the isolation of PHA during industrial production. To reduce the viscosity, addition of commercial preparations of nuclease or heat treatment is practiced, which adds to the cost of PHA production. The viscosity of cell lysates of *Pseudomonas putida* was reduced by expressing a staphylococcal nuclease in this organism (Boynton et al. 1999). In this study, a nuclease gene from *Staphylococcus aureus* was integrated into the chromosome of several strains of *Pseudomonas putida* and *R. eutropha*, and the expressed nuclease was directed to the periplasm or to the growth medium. During downstream processing, the viscosity of the lysate from a nuclease-integrated *Pseudomonas* strain was reduced to a level similar to that obtained with the wild-type strain after treatment with commercial nuclease.

Metabolic engineering also was performed successfully in eukaryotes including yeast (Leaf et al. 1996) and higher plants (see section 2 “Production of PHAs by Transgenic Plants” in this chapter) for the production of PHAs.

Commercial Applications

Production of Biopol

After the discovery of the thermoplastic properties of poly(3HB), W. R. Grace and Co. in the United States produced poly(3HB) for the possible commercial applications in the early 1960s, but the process was discontinued because of a low production efficiency and the lack of suitable recovery methods (Lee and Chang 1995a). In the 1970s, industrial interests in the production of PHB resumed at Imperial Chemical Industries (ICI, United Kingdom). Commercial production of PHA began at ICI BioProducts and Fine Chemicals, which later became Zeneca BioProducts, Billingham, United Kingdom, and was the only producer of PHA on a commercial scale (Byrom 1992, 1994; Lee and Chang 1995b). The trade name Biopol was used to describe the family of PHA polymers manufactured. In 1996,

Monsanto of St. Louis, in the United States, purchased the manufacturing technology from Zeneca BioProducts, but Monsanto ended its manufacturing of Biopol in 1998 (information provided by Monsanto).

Alcaligenes eutrophus (now *Ralstonia eutropha*) was the organism used in the commercial production of Biopol. The ICI process used a fed-batch system on a scale-up to 200,000 l in capacity and produced 300 t per year. Nutrient limitation was used as the strategy to control the onset of the PHA accumulation phase that follows a period of normal growth to produce cells. The organism grows in a mineral salts medium with glucose as the sole carbon and energy source. At the time of inoculation, the medium in the production stage fermentor contains a calculated amount of phosphate to allow production of a given amount of cell mass when the other nutrients are in excess. When the concentration of phosphate in the medium decreases to a threshold level so that it becomes limiting (about 60 h after inoculation), the cell begins to store PHA. At this point, more glucose is fed to the culture, if poly(3HB) is the desired product. The fermentation is continued for 40–60 h until the required PHA content is reached. Cell mass in excess of 100 g/l (dry weight) and a poly(3HB) content of 70–80 % are routinely obtained (Byrom 1992, 1994).

To produce the poly(3HB-co-3HV) copolymer, a mixture of glucose and propionic acid, instead of glucose alone, is fed to the culture when cells reach the PHA-accumulating stage under phosphate limitation. The 3HV content of the copolymer is controlled by adjusting the ratio of glucose to propionic acid in the feed. Normally, poly(3HB-co-3HV) copolymers containing 0–30 mol% of 3HV are produced. When the wild-type *R. eutropha* was used for poly(3HB-co-3HV) production, only about 30 % of the propionic acid supplied was incorporated into the copolymer because the major proportion of the added propionate was metabolized to acetate, which resulted in poly(3HB), or to CO₂. The problem was solved by the isolation of a mutant that cannot convert propionate to acetate. Use of this mutant reduced the required amount of propionate in the feed for copolymer production, and it not only lowered the cost of production but also alleviated the toxicity problem caused by high concentrations of propionate in the medium (Byrom 1994). Copolymers having a higher fraction (up to 90 mol%) of 3HV have been produced from butyric or pentanoic acid (Doi et al. 1990; Lee and Chang 1995a), but production on an industrial scale has not been reported.

The large-scale commercial production of PHA also required the development of procedures that were not necessary in the laboratory or in the pilot stages. In the laboratory, PHA is effectively extracted from the cell by using organic solvents such as chlorinated alkanes. Environmental considerations preclude the use of such organic solvents in the industrial process, and a water-based extraction procedure was successfully developed. The large size of the fermentor used in the industrial process also requires a much longer time for the harvesting of cells, which can lead to the degradation of the polymer during the harvesting and the extraction stages. These problems had

to be solved before commercial production of PHA became feasible. The white powder produced by the industrial process is melted, extruded, and converted into chips, which are supplied to the fabricators. The aqueous effluent generated by the industrial process can be treated in a conventional activated sludge plant.

Manufacturing Biopol-Based Consumer Products

Biopol can be processed on conventional equipment for polyolefin or other plastics, such as injection molding, extrusion blow molding, or fiber spray gun molding and therefore was used in the manufacturing of a wide range of consumer products. The first commercial product of PHA utilized Biopol and was introduced in 1990. It was a shampoo bottle for the German hair care company AWella, and it was available for some time on a limited market in Germany. Bottles for other cosmetics also came onto the market in Japan. Besides uses in the manufacturing of containers and bags, PHAs also can be used as coatings on items for food service or packaging. In the review by Steinbüchel (1996), many products manufactured from Biopol or other PHAs are described, and they include applications in agriculture, medicine, tobacco and foodstuff industry, chemical industry, fishing industry, and other areas.

Areas of Research and Development

Production of PHA Copolymers

The homopolymer of 3-hydroxybutyric acid or poly(3HB) is the prototype biodegradable PHA that is naturally produced by many bacteria. Because poly(3HB) is a crystalline and relatively brittle substance, it is not a suitable substitute for the commonly used thermoplastics manufactured from petrochemicals. Copolymers of hydroxyalkanoic acids, on the other hand, are less brittle and more elastic. Therefore, a major area of research on PHA is to develop organisms that can produce PHA copolymers with better mechanical properties and biodegradability.

The three key enzymes for PHA synthesis, 3-ketothiolase, 3-ketoacyl-CoA reductase, and PHA polymerase, can usually accommodate substrates with a slightly different chain length. Therefore, two or three kinds of hydroxyalkanoic acids can be incorporated during PHA synthesis to form a copolymer or terpolymer, if the additional kinds of CoA thioesters of hydroxyalkanoic acids can be made available to PHA polymerase through a special feeding regimen or metabolic engineering or a combination of both.

The first PHA copolymer to be produced commercially is poly(3HB-co-3HV), which was produced by *R. eutropha* when fed with glucose and propionic acid (Byrom 1992). The production strain is a glucose-utilizing mutant of *R. eutropha* (*A. eutrophus*) strain H16 that also can assimilate propionate more efficiently than the wild type. Propionic acid is

converted to propionyl-CoA first. Condensation of propionyl-CoA and acetyl CoA yields 3-ketovaleryl-CoA, which is then reduced to 3-hydroxyvaleryl-CoA to serve as a substrate for PHA polymerase. The concentration of poly(3HB-co-3HV) reached 70–80 % of the dry weight of the cell. By varying the ratio of glucose and propionic acid, the 3HV content in the polymer can be controlled at particular values in the range of 5–30 mol%. The PHA polymerase of *R. eutropha* accepts CoA thioesters of 3-, 4-, or 5-hydroxyalkanoic acid with 3–5 carbon atoms (Steinbüchel 1996), and PHA copolymers consisting of these monomers may be produced.

Ralstonia eutropha can produce poly(3HB-co-3HV) to a high concentration. However, this bacterium has a slow growth rate, is sensitive to propionic acid, and is hard to lyse. In addition, it also contains PHA-degrading enzymes, which can lower the yield or quality of PHA. Organisms that do not have these shortcomings were thus developed for the production of copolymers. Through metabolic engineering (see section ● “Metabolic Engineering” in this chapter) and special feeding programs, numerous recombinant organisms have been constructed to produce a range of PHA copolymers. Progress in this area has been rapid in recent years.

Poly(3HB-co-3HV) can now be produced by recombinant *E. coli* that acquired the PHA biosynthesis genes from *R. eutropha* or *A. latus* (Choi and Lee 1999b, 2000) or by the transgenic plants Arabidopsis and Brassica (Slater et al. 1999). Copolymers consisting of 3-HB and 3-hydroxyalkanoate units of 6–12 carbon atoms can be produced by recombinant *Pseudomonas putida* and *R. eutropha* that were PHA negative (Matsusaki et al. 2000). Poly(3-HB-co-4HB) can be produced by a PHA-producing recombinant *E. coli* that also was conferred with the ability to form 4-hydroxybutyryl-CoA from 4-aminobutyrate or glutamate (Valentin et al. 2000a). The genes for four enzymes were introduced into *E. coli* to afford the transformant the capacity to form 4-HB; the four enzymes are glutamate decarboxylase, 4-aminobutyrate:2-ketoglutarate transaminase, 4-hydroxybutyrate dehydrogenase, and acetyl CoA:4-hydroxybutyrate CoA-transferase. Various copolymers and terpolymers consisting of 3HB, 4HB, and 4HV can be produced by recombinant *E. coli* that received the butyrate kinase and phosphotransbutyrylase genes (*buk* and *ptb*) from *Clostridium acetobutylicum* and the PHA polymerase genes (*phaE* and *phaC*) from *Thiocapsa pfennigii* and is fed 3HB, 4HB, and 4HV (Liu and Steinbüchel 2000b). The PHA polymerase of *T. pfennigii* has a broader substrate range than the polymerase of *R. eutropha*.

Poly(3-hydroxypropionate-co-3HB) or poly(3HP-co-3HB) can be produced by a recombinant *E. coli* that acquired the *prpE* gene, encoding a propionyl-CoA synthetase, from *Salmonella* and the PHA biosynthesis genes from *R. eutropha* (Valentin et al. 2000b). The PHAs with medium-chain-length hydroxyalkanoates can be produced by PHA-producing recombinant strains of *E. coli* that are blocked for the ketoacyl-CoA degradation step of the β -oxidation and are fed fatty acids ranging in size from 6 to 18 carbon atoms (Ren et al. 2000). The number of copolymer-producing organisms as well as the

kind of copolymer produced can be expected to increase, and many new copolymers with better material properties should result from these efforts.

Production of Chiral Monomers

Because PHAs are polymers composed of chiral building blocks, hydrolysis of PHAs leads to the release of the chiral monomers, which are valuable starting material for the synthesis of pharmaceuticals and specialty chemicals. An efficient method has been reported for the production of enantiomerically pure (*R*)-(-)-hydroxyalkanoic acids by in vivo depolymerization of PHAs (Lee et al. 1999c). Those (*R*)-(-)-3-hydroxyalkanoic acids of 4–12 carbon atoms and (*R*)-(-)-3-hydroxy-5-phenylvaleric acid were prepared by providing the environmental condition under which cells possess a high activity of intracellular PHA depolymerase and a low activity of a key enzyme that could convert the chiral monomer into another compound. Monomer (*R*)-(-)-3-hydroxybutyric acid could be produced at a high yield in 30 min by in vivo depolymerization of poly(3HB) accumulated in *Alcaligenes latus*.

In Vitro Biosynthesis of PHA

Poly(3HB) is present as granules in bacterial cells and can reach sizes of up to 1 μm . When isolated by chloroform extraction, Poly(3HB) is highly crystalline and has molecular mass as large as 2×10^6 Da (see section ● “Physicochemical Properties” in this chapter). However, nuclear magnetic resonance (NMR) and wide-angle X-ray diffraction studies showed that in vivo, the poly(3HB) polymer is in a mobile, amorphous state (Barnard and Sanders 1989; Kawaguchi and Doi 1990). It was also suggested that additional agents, such as lipids and surfactants, may be needed as plasticizers if the poly(3HB) granule is assembled in vitro (Kawaguchi and Doi 1990). Any insight into these fundamental aspects of PHA biosynthesis can influence the development of an innovative approach for improving the industrial production of PHA.

Using purified PHA polymerase from *R. eutropha* and synthetically prepared (*R*)-3-hydroxybutyryl-CoA, macroscopic poly(3HB) granules were produced in vitro, and the procedure established the minimal requirement for poly(3HB) granule formation (Gerngross and Martin 1995). To make the in vitro biosynthesis practically useful, it is necessary to recycle coenzyme A, which is a product of the polymerization reaction. This has been accomplished by incorporating additional enzymes into the in vitro reaction (Jossek and Steinbüchel 1998; Liu and Steinbüchel 2000a). The use of butyrate kinase and phosphotransbutyrylase produced from cloned genes of the anaerobic bacterium *Clostridium acetobutylicum* allowed not only the recycling of CoA but also the in vitro synthesis of 3- and 4-hydroxyacyl-CoA, which then are converted to homo- or copolymers of PHA by the PHA polymerase from *Chromatium*

vinosum (Liu and Steinbüchel 2000a). In this butyrate kinase-linked *in vitro* system, ATP is the energy-rich compound that must be replenished to sustain the reaction.

Production of PHAs by Genetically Engineered Bacteria

In addition to the search for better PHA-producing organisms from nature, much effort has been devoted to the use of mutagenesis and recombinant DNA techniques to confer desired properties to selected bacteria for PHA production. These genetically engineered bacteria can produce PHAs of specific compositions for better material properties or can use less expensive substrates. The sections on metabolic engineering (see section ▶ “Metabolic Engineering” in this chapter) and production of PHA copolymers (see section ▶ “Production of PHA Copolymers” in this chapter) describe the construction of these recombinant bacteria and the novel PHAs produced by them. These recombinant organisms have been extensively used in fermentation studies (▶ Table 1.24) to maximize their productivity.

At the Korea Advanced Institute of Science and Technology (Taejon, South Korea), Dr. S. Y. Lee and coworkers have conducted extensive studies with recombinant strains of *E. coli* engineered for PHA production (Lee and Chang 1995b; Lee 1996a, b). The recombinant *E. coli* strain XL 1-Blue (pSYL107) harboring the PHA biosynthesis genes of *R. eutropha* and the *ftsZ* gene of *E. coli* on the high-copy-number plasmid pSYL107 produced poly(3HB) to 77 g/l, with a production rate of 2 g/l-h, in a defined medium with glucose as the carbon source (Wang and Lee 1998). Overexpression of the cell division protein FtsZ was crucial as it suppresses filamentation, which limits PHA production by *E. coli*. Further optimization of the fed-batch culture conditions increased the poly(3HB) concentration to 10⁴ g/l.

The recombinant *E. coli* strain XL1-Blue (pJC4) harboring the PHA biosynthesis genes of *A. latus* was used in pH-stat fed-batch cultures to produce poly(3HB-co-3HV) from glucose and propionic acid in a defined medium (Choi and Lee 1999b). In the absence of an induction treatment with acetic acid to stimulate the uptake and utilization of propionic acid, the cells accumulated a relatively low level (42.5 %) of poly(3HB-co-3HV). With the acetic acid induction treatment in the fed-batch culture, the recombinant *E. coli* produced a cell concentration of 141.9 g/l, a poly(3HB-co-3HV) concentration of 88.1 g/l, a poly(3HB-co-3HV) content of 62.1 %, and a 3HV fraction of 15.3 mol%. With the supplementation of oleic acid (to spare NADPH), the acetic acid induction, and an improved nutrient feeding strategy, the recombinant *E. coli* produced a cell concentration of 203.1 g/l, a poly(3HB-co-3HV) concentration of 158.8 g/l, a poly(3HB-co-3HV) content of 78.2%, and a 3HV fraction of 10.6 mol%, resulting in a high production rate of 2.88 g/l-h.

The result of an economic analysis was reported for the production of the poly(3HB-co-3HV) copolymer by a recombinant *E. coli* strain (Choi and Lee 2000). For this

analysis, simple NaOH digestion was used for the release of PHA from the cell because *E. coli* cells accumulating large amounts of PHA become very fragile (Choi and Lee 1999a). Because propionic acid is more expensive than glucose, the production cost for poly(3HB-co-3HV) increased linearly with the increase in the 3HV fraction in the copolymer. Not surprisingly, the production cost for the copolymer increased significantly when the 3HV content (increasing from 5 mol% to 50 mol%) was high and the 3HV yield (g of 3HV produced from each g of propionic acid used) was low (decreasing from 0.5 to 0.2).

The recombinant *E. coli* strain CGSC 4401, harboring the PHA biosynthesis genes of *A. latus*, produced poly(3HB) from whey (concentrated to contain 280 g of lactose equivalent per liter) in pH-stat fed cultures and reached a final cell concentration of 119.5 g/l and poly(3HB) concentration of 96.2 g/l in 37.5 h, resulting in a poly(3HB) productivity of 2.57 g/l-h (Ahn et al. 2000). This recombinant strain was then tested in a pH-stat cell recycle membrane system to produce poly(3HB) from similarly concentrated whey as a feeding solution (Ahn et al. 2001). The cell recycle system produced a final cell concentration of 194 g/l, a poly(3HB) concentration of 168 g/l, and a PHB content of 87 % in 36.5 h, resulting in a poly(3HB) productivity of 4.6 g/l-h. This level of PHA production is among the highest, other than the level produced by the methanol-grown bacteria (▶ Table 1.24).

A recombinant strain of *E. coli* was used in the development of a quantitative spectroscopic method for the measurement of poly(3HB) content in the cell (Kansiz et al. 2000). Fourier transform infrared (FTIR) spectroscopy and multivariate statistical methods were performed to determine the cellular poly(3HB) content, and a correlation coefficient of 0.988, with a standard error of 1.49 % poly(3HB), was obtained between the measured and the predicted values. The spectroscopic method circumvented the need to use solvents to extract the PHA before quantitative measurements.

Search for Inexpensive Carbon Substrates

Economic evaluation of the bacterial process for poly(3HB) production suggests that the cost of the carbon substrate accounts for up to 50 % of the total cost of poly(3HB) production (Choi and Lee 1997). A successful bacterial process for PHA production hence depends on the availability of a low-cost carbon substrate. Besides carbohydrates, organic acids and short-chain alcohols are also potential carbon substrates for the industrial production of PHAs. The cellular toxicity of the latter compounds, however, requires the isolation or identification of PHA producers that are more tolerant to these compounds. Reported progress includes the production of PHAs from whey or acetic and butyric acids.

Whey is a major by-product in the manufacturing of cheese or casein from milk. Whey from bovine milk contains approximately 4.5 % (wt/vol) lactose, 0.8 % (wt/vol) protein, 0.1–0.8 % (wt/vol) lactic acid, and 1 % (wt/vol) salts (Wong and Lee 1998).

In the United States, only half of the whey is recycled into useful products such as food ingredients and animal feed (Ahn et al. 2000). Because of its high volume and high biological oxygen demand, the rest of the whey is regarded as a pollutant that is costly to manage. Using a concentrated whey solution (280 g of lactose equivalent per liter) and a recombinant *E. coli* strain harboring PHA biosynthesis genes, final cell and poly(3HB) concentration reached 119.5 and 96.2 g/l, respectively, in 37.5 h, which resulted in a poly(3HB) productivity of 2.57 g/l-h (Ahn et al. 2000). These investigators found that whey could actually be concentrated by evaporation to contain 280 g of lactose per liter, which exceeds the solubility of lactose in water (200–210 g/l). By using the fed-batch culture with the highly concentrated whey solution and a stepwise decrease in the dissolved oxygen concentration from 40 % to 15 %, the highest poly(3HB) productivity was obtained. By using a cell recycle membrane system, these investigators obtained cell concentration, poly(3HB) concentration, and poly(3HB) content of 194 g/l, 168 g/l, and 87 %, respectively (Ahn et al. 2001). In localities where the disposal of whey is a problem, the production of PHA from this carbon source should provide a higher economical return.

In an attempt to improve the economics of the anaerobic acetone-butanol (AB) fermentation, scientists in Vienna, Austria, are testing the by-products, acetate and butyrate, from the AB fermentation as substrates for PHA production (Parrer et al. 2000). A butanol-tolerant strain of *Alcaligenes* was isolated that could convert acetate (5 g/l), butyrate (7 g/l), and added valerate (3 g/l) to poly(3HB-co-3HV) copolymers (37 mol% 3HV) that constituted 52 % of the cellular dry matter (Parrer et al. 2000).

Production of PHAs by Transgenic Plants

The established commercial process for the production of Biopol used bacteria (see section “Production of Biopol” in this chapter). However, the high cost of the conventional carbon substrates has limited the usefulness of the bacterial process. Transgenic plants, which harbor the bacterial genes for the synthesis of PHAs, have been developed to couple directly the photosynthetic activity of the green plants to the production of PHAs (Poirier et al. 1992; Nawrath et al. 1994; John and Keller 1996; Hahn et al. 1997; Slater et al. 1999).

Initially, the *R. eutropha* (*A. eutrophus*) genes for acetoacetyl-CoA reductase (*phbB*) and poly(3HB) polymerase (*phbC*) were introduced into *Arabidopsis thaliana* through Ti plasmid-mediated transformation and cross-pollination of homozygous transgenic lines harboring either the *phbB* or the *phbC* gene (Poirier et al. 1992). These two introduced genes are expressed in the cytoplasm of the transformed plant, where an endogenous 3-ketothiolase is present. Poly(3HB) is produced by the transgenic plant, but the expression of large amounts of acetoacetyl-CoA reductase in the cytoplasm of the transgenic plants caused a significant reduction in growth and seed production.

This problem was alleviated when the three *R. eutropha* genes (*phbA*, *phbB*, and *phbC*) were properly fused to signal

sequences to target the expression of these genes in plastids, where storage lipids are normally synthesized. These plants accumulated poly(3HB) up to 14 % of the dry weight of leaves, as 0.2–0.7- μ m granules within plastids (Nawrath et al. 1994). However, varying amounts of poly(3HB) were produced by different lines of the triple hybrids, and the variation appears to be related to the widely different levels of thiolase and acetoacetyl-CoA reductase activities that are expressed in the hybrid plants. Compared with starch synthesis, the average daily rate of poly(3HB) synthesis is relatively low, although poly(3HB) is not reutilized by the plant and hence acts as a terminal carbon sink.

The copolymer poly(3-hydroxybutyrate-co-3-hydroxyvalerate) or poly(3HB-co-3HV) was produced in transgenic *Arabidopsis thaliana* and in the seeds of transgenic *Brassica napus* (oilseed rape) by diverting metabolic pools of acetyl CoA and threonine into PHA production through four introduced genes that are targeted for expression in the plastids (Slater et al. 1999). The four genes involved are:

1. The *E. coli ilvA* gene, which codes for the threonine deaminase, an enzyme converting threonine to 2-ketobutyrate (the plant pyruvate dehydrogenase complex can convert 2-ketobutyrate to propionyl-CoA, which is the precursor for (R)-3-hydroxyvaleryl-CoA).
2. The *R. eutropha bktB* gene, which codes for the 3-ketothiolase that can produce both acetoacetyl CoA (from acetyl CoA) and 3-ketovaleryl-CoA (from acetyl CoA and propionyl-CoA).
3. The *R. eutropha phbB* gene for acetoacetyl-CoA reductase.
4. The *phbC* gene, for the poly(3HB) polymerase, from either *R. eutropha* or *Nocardia corallina*. This designed pathway allows the production of PHA copolymers by the transgenic plants, but the level of accumulated copolymer is low, less than 3 % of plant tissue dry weight (*Arabidopsis*) or the seed weight (*Brassica*). These investigators expect that polymer concentrations in plants will need to reach at least 15 % of dry weight for economical production to be feasible.

The *R. eutropha phbB* and *phbC* genes also have been introduced into cotton (*Gossypium hirsutum*) with the fiber cells as the target site of expression during early or late fiber development stages (John and Keller 1996). The objective was to alter the characteristics of the cotton fibers. Although poly(3HB) was present at a low level in the fiber (3.4 mg/g of dry fiber), it already increased the heat capacity and hence improved the insulation properties of the purified cotton. Future goals for the effort are to improve cotton characteristics such as dyeability, warmth, and wrinkle resistance.

Genes for poly(3HB) biosynthesis have been introduced into Black Mexican sweet corn (maize, *Zea mays*) and expressed in cultured cells (Hahn et al. 1997). During a 2-year period in a bioreactor, the introduced *phbB* and *phbC* genes were unstable, whereas the thiolase activity was constant. Also, the transformed plant cells grew more slowly than the wild-type cells. The construction of suitable plant species for the production of PHAs in specific cellular locations and at the right time will depend on progress in

knowledge and tools for genetic and metabolic engineering. The introduction of new characteristics into plant materials, such as the cotton fibers, by the incorporation of PHAs represents an excellent application for the biodegradable polymer.

Patent and Regulatory Issues

Many processes for the production and application of PHAs are under the protection of patents. Steinbüchel (1996) compiled 74 patents and patent applications in his review, and 16 of them were assigned to ICI. Among them, 33 patents or patent applications were for the production of PHA, encompassing the poly(3HB) homopolymer (e.g., EP 46344-A1, EP 144017-A1, JP 06251889-A2, and US 4910145), the poly(3HB-co-3HV) copolymer (e.g., EP 204442-A2, EP 288908-A2, EP 396289-A1, and EP 90304267.9), the poly(3HB-co-4HV) copolymer (EP466050-A1), and the poly(3HB-co-4HB) copolymer (e.g., JP 2234683-A2, JP 03216193-A2, and JP 03292889-A2), as well as the PHA biosynthesis genes (US 5229279, US 52450023, and US 5250430, all assigned to Metabolix); 23 were for the isolation of PHA, including those for the poly(3HB) homopolymer (e.g., EP 46335, EP 145233-A1, and JP 62205787-A2) and the poly(3HB-co-3HV) copolymer (EP 431883-A1 and WO 9118995-A1); 8 were for the processing or modification of PHA into films (US 3182036), 3HB monomer and oligomers (US 4365088-A1 and EP 320046-A1) and 3HB esters (EP 377260-A1 and US 5107016-A1); 10 were for the applications of PHA, which include microporous membranes (JP 60137402-A1), surgical devices for bone fractures (WO 8607250-A1), microcapsules for retard materials (DE 3428372-A1 and EP 315875-A1), cigarette filter tips (DE 4013293-C2 and DE 4013304-A1), toner and developer for photocopier (US 5004664-A1), flavor delivery systems (WO 9209210-A1), and cream substitute (WO 9209211-A1). The number of pertinent patents can be expected to increase when more recombinant organisms, novel production systems, and applications are developed.

When the PHA-based consumer products or medical devices are proclaimed to be biodegradable, government regulations and standards become necessary to safeguard the quality of the environment and the welfare of patients. It is necessary to define biodegradability, standards, and the test methods. At the Third International Scientific Workshop on Biodegradable Plastics that was held in Osaka, Japan, in November 1993, a session was devoted to government policy, regulations, and standards (Albertsson and Marchessault 1994). Pertinent government policy and regulations of the United States (Narayan 1994), Italy (Chiellini 1994), and Korea (Chang et al. 1994) can be found in these publications.

Prospects

The commercialization of consumer goods manufactured from Biopol has confirmed the usefulness of PHAs as a substitute for petrochemical-derived thermoplastics. The discontinuation of

the Biopol process, however, illustrates that the high cost of bacterial fermentation will limit the commercial potential of PHAs that are produced by fermentation-based processes. The result of a case study casts doubt on the environmental benefits of producing PHAs from corn-derived glucose (Gerngross 1999). Because a considerable amount of fossil fuels is needed to produce corn and then to convert corn starch into glucose for bacterial fermentation, a greater amount of fossil fuels (2.39 kg vs. 2.26 kg) may actually be required to produce 1 kg of PHAs than to produce 1 kg of polystyrene from petrochemicals. To overcome this unfavorable situation, less expensive carbon substrates are being sought to replace glucose as the starting material. Whey has been identified as a promising alternative substrate (Ahn et al. 2001). In addition, phototrophic organisms are being tested as the primary producers of PHAs so that CO₂ can serve as the carbon substrate. Transgenic plants with introduced bacterial genes have been shown to produce PHAs, but the level of PHAs produced is so far lower than that in the bacteria. Another approach is to use unicellular phototrophic bacteria, which may be more efficient than the higher plants in the utilization of carbon and energy, to produce PHAs. The use of less expensive carbon substrates or phototrophic bacteria may allow the development of more economical and sustainable processes for the future commercial production of PHAs.

Besides uses as a commodity chemical for the manufacturing of consumer goods, PHAs also have other possible novel applications. For example, PHAs may be used in the delivery system for the long-term release of drugs, in open-heart surgery as nonwoven patches for pericardium repair, or in orthopedic medicine because the piezoelectric properties of PHAs stimulate bone growth (Steinbüchel 1996). It has also been suggested that PHAs can serve as the source of a broad range of chiral hydroxy acids, which are valuable building blocks for the pharmaceutical industry (Lee et al. 1999c). These novel uses for PHAs will ensure a future for this class of biomaterial whether or not it will be produced by phototrophic or nonphototrophic organisms.

References

- Adamse AD (1980) New isolation of *Clostridium acetivum*, (Wieringa). *Ant v Leeuwenhoek* 46:523–531
- Agreda VH, Zoeller JR (1993) Acetic acid and its derivatives. Dekker, New York
- Ahn WK, Park SJ, Lee SY (2000) Production of poly(3-hydroxybutyrate) by fed-batch culture of recombinant *Escherichia coli* with a highly concentrated whey solution. *Appl Environ Microbiol* 66:3624–3627
- Ahn WS, Park SJ, Lee SY (2001) Production of poly(3-hydroxybutyrate) from whey by cell recycle fed-batch culture of recombinant *Escherichia coli*. *Biotechnol Lett* 23:235–240
- Albertsson A-C, Marchessault RH (1994) Governmental policy, regulations and standards. In: Doi Y, Fukuda K (eds) *Biodegradable plastics and polymers*. Elsevier Science, Amsterdam, pp 313–318
- Allgeier RJ, Hildebrandt FM (1960) Developments in vinegar manufacture. *Adv Appl Microbiol* 8:163–182
- Alpers J (1999) Engineering metabolism for commercial gains. *Science* 283:1625–1626
- Althouse JW, Tavlarides LL (1992) Analysis of organic extractant systems for acetic acid removal for calcium magnesium acetate production. *Ind Eng Chem Res* 31:1971–1981

- Aminabhavi TM, Balundgi RH (1990) A review of biodegradable plastics. *Polym Plast Technol Eng* 29:235–262
- Anastassiadis S, Aivasidis A, Wandrey C (1999) Process for the production of gluconic acid with a strain of *Aureobasidium pullulans* (deBray) Arnaud. US Patent 5692286
- Anderson AJ, Dawes EA (1990) Occurrence, metabolism, metabolic role, and industrial uses of bacterial polyhydroxyalkanoates. *Microbiol Rev* 54:450–472
- Andreesen JR, Gottschalk G, Schlegel HG (1970) *Clostridium formicoaceticum* nov. spec. isolation description, and distinction from *C. aceticum* and *C. thermoaceticum*. *Arch Mikrobiol* 72:154–174
- Andrianova YE, Bakuridze TL, Yargunov VG, Zhurov IV, Vinter VG (1998) Effects of succinate on the growth rates of potato, Rauwolfia, and ginseng in vitro. *Prikl Biokhim Mikrobiol* 34:435–438
- Anonymous (1993) Chem Market Report March 1 7
- Anonymous (1999) All-microbial route yields chiral building blocks. *Chem Eng News* 77(8):57
- Anonymous (2000) Chemical prices. *Chem Market Report* 257(23):26–33
- Arihara K, Luchansky JB (1995) Dairy lactobacilli. In: Hui YH, Khachatourian GG (eds) *Food biotechnology: microorganisms*. VCH, New York, pp 609–643
- Asai T (1968) Acetic acid bacteria: classification and biochemical activities. University Press of Tokyo/University Park Press, Tokyo/Baltimore
- Attwood MA, van Dijken JP, Pronk JT (1991) Glucose metabolism and gluconic acid production by *Acetobacter diazotrophicus*. *J Ferm Bioeng* 72:101–105
- Auvray F, Codderville M, Ritzenthaler P, Dupont L (1997) Plasmid integration in a wide range of bacteria mediated by integrase of *Lactobacillus delbrueckii* bacteriophage mv4. *J Bacteriol* 179:1837–1845
- Babel W, Iske U, Jechorek M, Miethe D (1987) Method for production of products by fermentation of methanol. German Patent GDR 251,571. *Chem Abstr* 109:36639
- Babel W, Mueller R, Miethe D, Iske U (1988) Continuous microbial synthesis of products of incomplete oxidation, such as gluconic acid. German Patent DD 253,836. *Chem Abstr* 109:108918
- Babel W, Miethe D, Iske U, Sattler K, Richter HP, Schmidt J, Babel W, Lofhagen N, Miethe D, Mueller R, Iske U, Jechorek M, Dueresch R (1991) Microbial manufacture of gluconic acid. German Patent DD 293, 135. *Chem Abstr* 115:278185
- Bahner B (1994) Chemical marketing reporter. March 21st 14
- Balch WE, Schoberth S, Tanner RS, Wolfe RS (1977) Acetobacterium, a new genus of hydrogen-oxidizing carbon dioxide-reducing, anaerobic bacteria. *Int J Syst Bacteriol* 27:355–361
- Barnard GN, Sanders JKM (1989) The poly- β -hydroxybutyrate granule in vivo: a new insight based on NMR spectroscopy of whole cells. *J Biol Chem* 264:3286–3291
- Basu R, Bershears JS, Clausen EC (1999) Calcium magnesium acetate at lower production costs: production of CMA deicer from biomass. US DOT Publication No. FHWA-RD-98-055
- Benninga H (1990) A history of lactic acid making. Kluwer Academic, Dordrecht/Boston
- Beppu T (1993) Genetic organization of acetobacter for acetic acid fermentation. *Ant v Leeuwenhoek* 64:121–135
- Berglund KA, Elankovan P, Glassner DA (1991) Carboxylic acid purification and crystallization process. US Patent 5,034,105
- Berglund KA, Yedur S, Dunuwila DD (1999) Succinic acid production and purification. US Patent 5,958,744
- Bernhauer K (1924) Zum Problem der Säurebildung durch *A. niger* Biochem. Z. 153:517–521
- Bernhauer K (1928) Über die Charakterisierung der Stämme von *A. niger* auf Grund ihres biochemischen Verhaltens Biochem.Z 197:278–287
- Bhowmik T, Steele JL (1994) Cloning, characterization, and insertional inactivation of *Lactobacillus helveticus* D(–)-lactate dehydrogenase. *Appl Microbiol Biotechnol* 41:432–439
- Bigelis R, Tsai SP (1995) Microorganisms for organic acid production. In: Hui YH, Khachatourians GG (eds) *Food biotechnology: microorganisms*. VCH, New York, pp 239–280
- Blom RH, Pfeiffer VF, Moyer AJ, Traufler DH, Conway HF, Crocker CK, Farison RE, Hannibal DV (1952) Sodium gluconate production-fermentation with *A. niger*. *Ind Eng Chem* 44:435–440
- Bock A, Sawers G (1996) “Fermentation” in *Escherichia coli* and Salmonella. In: Neidhardt FC (ed) *Cellular and molecular biology*. ASM Press, Washington, pp 262–282
- Boutroux L (1880) Sur une fermentation nouvelle du glucose. *CR Acad Sci* 91:236–238
- Boynton ZL, Koon JJ, Brennan EM, Clouart JD, Horowitz DM, Gerngross TU, Huisman GW (1999) Reduction of cell lysate viscosity during processing of poly(3-hydroxyalkanoates) by chromosomal integration of the Staphylococcal nuclease gene in *Pseudomonas putida*. *Appl Environ Microbiol* 65:1524–1529
- Braun M, Mayer F, Gottschalk G (1981) *Clostridium aceticum* (Wieringa) a microorganism producing acetic acid from molecular hydrogen and carbon dioxide. *Arch Microbiol* 128:288–293
- Brown AT, Breeding LC (1980) Carbon dioxide metabolism by *Actinomyces viscosus*: pathways for succinate and aspartate production. *Infect Immun* 28:82–91
- Bucholz K, Gödelmann B (1978) Macrokinetics and operational stability of immobilized glucose oxidase and catalase. *Biotechnol Bioeng* 20:1201–1220
- Buchta K (1983) Lactic acid. In: Rehm HJ, Reed G (eds) *Biotechnology*. Verlag Chemie, Weinheim, pp 409–417
- Busche RM (1985) Acetic acid manufacture – fermentation alternatives. In: Cherenisnoff PN, Ouellette RP (eds) *Biotechnology applications and research technomic*. Technomic Lancaster PA, pp 88–102
- Busche RM (1991) Extractive fermentation of acetic acid: economic tradeoff between yield of clostridium and concentration of acetobacter. *Appl Biochem Biotechnol* 28(29):605–621
- Byrom D (1992) Production of poly- β -hydroxybutyrate: poly- β -hydroxyvalerate copolymers. *FEMS Microbiol Rev* 103:247–250
- Byrom D (1994) Polyhydroxyalkanoates. In: Mobley DP (ed) *Plastics from microbes*. Hanser, Munich, pp 5–33
- Carr NG (1966) The occurrence of poly- β -hydroxybutyrate in the blue-green alga, *Chloroglea fritschii*. *Biochim Biophys Acta* 120:308–310
- Cauvin B, Luchansky JB (1992) Advances in electro-transformation of Gram-positive bacteria. *Bio-rad Laboratories Bulletin* 1350A
- Chang HN, Kim YC, Lee SY, Kim BS (1994) Current status of biodegradable plastics in Korea: research, commercial production and government policy. In: Doi Y, Fukuda K (eds) *Biodegradable plastics and polymers*. Elsevier Science, Amsterdam, pp 286–297
- Chang D-E, Jung H-C, Rhee J-S, Pan J-G (1999) Homofermentative production of D- or L-lactate in metabolically engineered *Escherichia coli* RR1. *Appl Environ Microbiol* 65:1384–1389
- Cheng P, Mueller RE, Jaeger S, Bajpai R, Iannotti EL (1991) Lactic acid production from enzyme-thinned corn starch using *Lactobacillus amylovorus*. *J Ind Microbiol* 7:27–34
- Cheryan M (1999) Acetic acid production. In: Lederberg J (ed) *Encyclopedia of microbiology*. Academic, San Diego
- Cheryan M, Paretkh S, Shah M, Witjitra K (1997) Production of acetic acid by *Clostridium thermoaceticum*. *Adv Appl Microbiol* 43:1–33
- Chiellini E (1994) Status of government policy, regulation and standards on the issue of biodegradable plastic materials in Italy. In: Doi Y, Fukuda K (eds) *Biodegradable plastics and polymers*. Elsevier Science, Amsterdam, pp 273–285
- Choi J, Lee SY (1997) Process analysis and economic evaluation for poly(3-hydroxybutyrate) production by fermentation. *Bioproc Eng* 17:335–342
- Choi J, Lee SY (1999a) Efficient and economical recovery of poly(3-hydroxybutyrate) from recombinant *Escherichia coli* by simple digestion with chemicals. *Biotechnol Bioeng* 62:546–553
- Choi J, Lee SY (1999b) High-level production of poly(3-hydroxybutyrate-co-3-hydroxyvalerate) by fed-batch culture of recombinant *Escherichia coli*. *Appl Environ Microbiol* 65:4363–4368
- Choi J, Lee SY (2000) Economic consideration in the production of poly(3-hydroxybutyrate-co-3-hydroxyvalerate) by bacterial fermentation. *Appl Microbiol Biotechnol* 53:646–649

- Chun VH, Rogers PL (1988) The simultaneous production of sorbitol from fructose and gluconic acid from glucose using an oxidoreductase of *Zymomonas mobilis*. *Appl Microbiol Biotechnol* 29:19–24
- Clark DP (1989) The fermentation pathways of *Escherichia coli*. *FEMS Microbiol Rev* 63:223–234
- Clark DP, Cunningham PR, Reams SG, Mat-Jan F, Mohammedkhani R, Williams CR (1988) Mutants of *Escherichia coli* defective in acid fermentation. *Appl Biochem Biotechnol* 17:163–173
- Cocconcelli PS, Gasson MJ, Morelli L, Bottazzi V (1991) Single-stranded DNA plasmid vector construction and cloning of *Bacillus stearothermophilus* α -amylase in *Lactobacillus*. *Res Microbiol* 142:643–652
- Crow VL (1987) Citrate cycle intermediates in the metabolism of aspartate and lactate by *Propionibacterium freudenreichii* subsp. *shermanii*. *Appl Environ Microbiol* 53:2600–2602
- Currie JN, Finlay A (1933) Fermentation such as the production of D-gluconic acid. US Patent 1908225. *Chem Abstr* 27:3774
- Currie JN, Carter RH (Charles Pfizer, and Co.). (1930) Gluconic acid. US Patent 1896811. *Chem Abstr* 27:2757
- Datta R (1989) Recovery and purification of lactate salts from whole fermentation broth by electrodialysis. US Patent to Michigan Biotech Institute 4,885,247
- Datta R (1992) Process for the production of succinic acid by anaerobic fermentation. US Patent 5,143,833
- Datta R, Glassner DA, Jain MK, Vick Roy JR (1992) Fermentation and purification process for succinic acid. US Patent 5,168,055
- Datta R, Tsai S-P, Bonsignore P, Moon S-H, Frank JR (1995) Technological and economic potential of poly (lactic acid) and lactic acid derivatives. *FEMS Microbiol Rev* 16:221–231
- Davidson BE, Llanos RM, Cancilla MR, Redman NC, Hillier AJ (1995) Current research on the genetics of lactic acid production in lactic acid bacteria. *Int Dairy J* 5:763–784
- Dawes EA, Senior PJ (1973) The role and regulation of energy reserve polymers in microorganisms. *Adv Microb Physiol* 10:135–266
- De Koning G, Kellerhals M, van Meurs C, Witholt B (1997) In: Eggink G, Steinbuechel A, Poirer Y, Witholt B (eds) Proceedings of the 1996 international symposium on bacterial polyhydroxyalkanoates. A process for the production of bacterial medium-chain-length poly(R)-3-hydroxyalkanoates: reviewing the status quo. NRC Research Press, Davos, Switzerland, pp 137–142
- Demirci A, Pometto AL 3rd (1992) Enhanced production of D(-) lactic acid by mutants of *Lactobacillus delbrueckii* ATCC 9649. *J Ind Microbiol* 11:23–28
- Demirci A, Pometto AL 3rd (1995) Repeated-batch fermentation in biofilm reactors with plastic composite supports for lactic acid production. *Appl Microbiol Biotechnol* 43:585–589
- Dennis D, Kaplan NO (1960) D- and L-lactic acid dehydrogenases in *Lactobacillus plantarum*. *J Biol Chem* 235:810–818
- DeVos WM, Simons GFM (1994) Gene cloning and expression systems in *Lactococci*. In: Gasson MJ, DeVos WM (eds) Genetics and biotechnology of lactic acid bacteria. Blackie Academic/Professional Publishers, London/New York, pp 52–105
- DeWilt HGJ (1972) Oxidation of glucose to gluconic acid. *Ind Eng Chem Prod Res Dev* 11:370–378
- Djordjevic GM, O'Sullivan DJ, Walker SA, Conkling MA, Kaenhammer TR (1997) Triggered-suicide system designed for bacteriophage defense of *Lactococcus lactis*. *J Bacteriol* 179:6741–6748
- Doi Y (1990) Microbial polyesters. VCH, New York
- Doi Y, Fukuda K (eds) (1994) Biodegradable plastics and polymers. Elsevier Science, Amsterdam
- Doi Y, Segawa A, Kawaguchi Y, Kunioka M (1990) Cyclic nature of poly(3-hydroxyalkanoate) metabolism in *Alcaligenes eutrophus*. *FEMS Microbiol Lett* 67:165
- Donnelly MI, Millard CS, Clark DP, Chen MJ, Rathke JW (1998a) A novel fermentation pathway in an *Escherichia coli* mutant producing succinic acid, acetic acid, and ethanol. *Appl Biochem Biotechnol* 70–72:187–198
- Donnelly M, Millard CS, Stols L (1998b) Mutant *E. coli* strain with increased succinic acid production. US Patent 5,770,435
- Drake HL (1994) Acetogenesis, acetogenic bacteria, and the acetyl-CoA “Wood/Ljungdahl” pathway: past and current perspectives. In: Drake HL (ed) Acetogenesis. Chapman and Hall, New York, pp 3–60
- Dubos RJ (1988) Pasteur and modern science. Science Tech, Madison
- Ebner H (1985) Process for the production of vinegar with more than 12g/100ml acetic acid. US Patent 4,503,078
- Ebner H, Follmann H (1983) Acetic acid. In: Rehm HJ, Reed G (eds) Biotechnology, vol 3. VCH, Weinheim, pp 387–407
- Ebner H, Sellmer S, Follmann H (1996) Acetic acid. In: Roehr M (ed) Biotechnology, 2E, vol 6, Products of Primary Metabolism. VCH Weinheim, Germany, vol 6, pp 381–401
- Eden G, Fuchs G (1982) Total synthesis of acetyl CoA involved in autotrophic CO₂ fixation in *Acetobacterium woodii*. *Arch Microbiol* 133:66–74
- Eden G, Fuchs G (1983) Autotrophic CO₂ fixation in *Acetobacterium woodii*. II: demonstration of enzymes involved. *Arch Microbiol* 135:68–73
- Entani E, Ohmori S, Masai H, Suzuki K-I (1985) *Acetobacter polyoxogenes*, sp. nov., a new species of an acetic acid bacterium useful for producing vinegar with high acidity. *J Gen Appl Microbiol* 31:475–490
- Evans JD, Martin SA (1997) Factors affecting lactate and malate utilization by *Selenomonas ruminantium*. *Appl Environ Microbiol* 63:4853–4858
- Fiedler S, Steinbuechel A, Rehm B (2000) PhaGe-mediated synthesis of poly(3-hydroxyalkanoates) consisting of medium-chain-length constituents from nonrelated carbon sources in recombinant *Pseudomonas fragi*. *Appl Environ Microbiol* 66:2117–2124
- Flores-Encarnacion M, Contreras-Zentella M (1999) The respiratory system and diazotrophic activity of *Acetobacter diazotrophicus* PAL5. *J Bacteriol* 181:6987–6995
- Fontaine F, Peterson WH, McCoy E, Johnson MJ, Ritter G (1942) A new type of glucose fermentation by *Clostridium thermoaceticum*, n. sp. *J Bacteriol* 43:701–715
- Forde A, Daly C, Fitzgerald GF (1999) Identification of four phage resistance plasmids from *Lactococcus lactis* subsp. *cremoris* HO₂. *Appl Environ Microbiol* 65:1540–1547
- Fujimaki T (1998) Processability and properties of aliphatic polyesters, “BIONELLE”, synthesized by polycondensation reaction. *Polym Degrad Stabil* 59:209–214
- Fukaya M, Tagami H, Tayama K, Okumura H, Kawamura Y, Beppu T (1989) Spheroplast fusion of *Acetobacter aceti* and its application to the breeding of strains for vinegar production. *Agric Biol Chem* 53:2435–2440
- Fukaya M, Park YS, Toda K (1992) Improvement of acetic acid fermentation by molecular breeding. *J Appl Bacteriol* 73:447–454
- Gasson MJ, DeVos WM (eds) (1994) genetics and biotechnology of lactic acid bacteria. Blackie Academic/Professional Publishers, London/New York
- Gerngross TU (1999) Can biotechnology move us toward a sustainable society? *Nat Biotechnol* 17:541–544
- Gerngross TU, Martin DP (1995) Enzyme-catalyzed synthesis of poly[R(-)-3-hydroxybutyrate]: formation of macroscopic granules in vitro. *Proc Natl Acad Sci USA* 92:6279–6283
- Ghose TK, Bhadra A (1985) Acetic acid. In: Moo-Young M (ed) Biotechnology, vol 3. Pergamon Press, New York, pp 701–729
- Gilles M, Kerstens K, Hoste B, Janssens D, Kroppenstedt RM, Stephens MP, Teixeira KRS, Dobreiner J, DeLey J (1989) *Acetobacter diazotrophicus* sp. nov. a nitrogen-fixing acetic acid bacterium associated with sugar cane. *Int J Syst Bacteriol* 39:361–364
- Glassner DA, Datta R (1992) Process for the production and purification of succinic acid. US Patent 5,143, 834
- Gokarn RR, Eiteman MA, Martin SA, Eriksson KEL (1997a) Production of succinate from glucose, cellobiose, and various cellulosic materials by the ruminal anaerobic bacteria *Fibrobacter succinogenes* and *Ruminococcus flavefaciens*. *Appl Biochem Biotechnol* 68:69–80
- Gokarn RR, Eiteman MA, Sridhar J (1997b) Production of succinate by anaerobic microorganisms. *Am Chem Soc Symp Ser* 666:237–253
- Gokarn RR, Eiteman MA, Altman E (1998) Expression of pyruvate carboxylase enhances succinate production in *Escherichia coli* without affecting glucose uptake. *Biotechnol Lett* 20:795–798

- Gokarn RR, Eiteman MA, Altman E (1999) Pyruvate carboxylase overexpression for enhanced production of oxalacetate-derived biochemicals in microbial cells. PCT International Patent Application WO 99/53035
- Goldberg I, Lonberg-Holm K, Bagley EA, Stieglitz B (1983) Improved conversion of fumarate to succinate by *Escherichia coli* strains amplified for fumarate reductase. *Appl Environ Microbiol* 45:1838–1847
- Gosalbes MJ, Esteban CD, Galan JL, Perez-Martinez G (2000) Integrative food-grade expression system based on the lactose regulon of *Lactobacillus casei*. *Appl Environ Microbiol* 66:4822–4828
- Gottschalk G (1985) Bacterial metabolism, 2nd edn. Springer, New York, p 247
- Gottschalk G (1986) Bacterial metabolism, 2nd edn. Springer, New York, pp 97–98
- Gruber PR, Hall ES, Kolstad JJ, Iwen ML, Benson RD, Borchardt RL (1992) Continuous process for manufacture of lactide polymers with controlled optical purity. US Patent to Cargill, Inc 5,142,0023
- Gruber PR, Hall ES, Kolstad JJ, Iwen ML, Benson RD, Borchardt RL (1994) Continuous process for manufacture of lactide polymers with purification by distillation. US Patent to Cargill, Inc 5,357,035
- Guettler MV, Jain MK (1996) Method for making succinic acid, *Anaerobiospirillum succiniciproducens* variants for use in process and methods for obtaining variants. US Patent 5,521,075
- Guettler MV, Jain MK, Rumler D (1996a) Method for making succinic acid, bacterial variants for use in the process, and methods for obtaining variants. US Patent 5,573, 931
- Guettler MV, Jain MK, Soni BK (1996b) Process for making succinic acid, microorganisms for use in the process and methods of obtaining the microorganisms. US Patent 5,504,004
- Guettler MV, Jain MK, Soni BK (1998) Process for making succinic acid, microorganisms for use in the process and methods of obtaining the microorganisms. US Patent 5,723,322
- Guettler MV, Rumler D, Jain MK (1999) *Actinobacillus succinogenes* sp. nov., a novel succinic-acid-producing strain from the bovine rumen. *Int J Syst Bacteriol* 49:207–216
- Gupta A, Verma V, Quazi GN (1997) Transposon induced mutation in *Gluconobacter oxydans* with special reference to its direct glucose oxidation metabolism. *FEMS Microbiol Lett* 147:181–188
- Gupta A, Felder M, Yerma Y, Cullum J, Qazi GN (1999) A mutant of *Gluconobacter oxydans* deficient in gluconic acid dehydrogenase. *FEMS Microbiol Lett* 179:501–506
- Hahn JJ, Eschenlauer AC, Narrol MH, Somers DA, Sriene F (1997) Growth kinetics, nutrient uptake, and expression of the *Alcaligenes eutrophus* poly(β -hydroxybutyrate) synthesis pathway in transgenic maize cell suspension cultures. *Biotechnol Prog* 13:347–354
- Han IS, Cheryan M (1996) Downstream processing of acetate fermentation broths by nanofiltration. *Appl Biochem Biotechnol* 57(58):19–28
- Harlander SK (1987) Transformation of *Streptococcus lactis* by electroporation. In: Ferretti J, Curtiss R (eds) Streptococcal genetics. American Society for Microbiology, Washington, pp 229–233
- Haywood GW, Anderson AJ, Chu L, Dawes EA (1988) The role of NADH- and NADPH-linked acetoacetyl-CoA reductases in the poly-3-hydroxybutyrate synthesizing organism *Alcaligenes eutrophus*. *FEMS Microbiol Lett* 52:259–264
- Hein S, Tran H, Steinbüchel A (1998) *Synechocystis* sp. PCC6803 possesses a two-component polyhydroxyalkanoic acid synthase similar to that of anoxygenic purple sulfur bacteria. *Arch Microbiol* 170:162–170
- Herrick HT, May OE (1928) The production of gluconic acid by the *Penicillium luteum* purpurogenum group II: some optimal conditions for acid formation. *J Biol Chem* 77:185–195
- Hlasiwetz H, Habermann J (1870) Zur Kenntnis einiger Zuckerarten (Glucose, Rhozucker, Levulose, Sorbin, Phloroglucin). *Ann Chem Pharm* 155:128–144
- Ho K-LG, Pometto AL 3rd, Hinz PN (1997) Optimization of L-(+)-lactic acid production by ring and disc plastic composite supports through repeated-batch biofilm fermentation. *Appl Environ Microbiol* 63:2533–2542
- Hocking PJ, Marchessault RH (1994) Biopolymers. In: Griffin GJL (ed) Chemistry and technology of biodegradable polymers. Chapman and Hall, London, pp 48–96
- Holten CM, Muller A, Rehbinder D (eds) (1971) Lactic acid. Weinheim/Bergstr Germany
- Howaldt M, Gottlob A, Kulba KD, Chmiel H (1988) Simultaneous conversion of glucose/fructose mixtures in a membrane reactor. *Ann NY Acad Sci* 542:400–405
- Howaldt M, Kulbe KD, Chmiel H (1990) A continuous enzyme membrane reactor retaining native nicotinamide cofactor NAD (H). *Ann NY Acad Sci* 589:253–260
- Hrabak O (1992) Industrial production of poly- β -hydroxybutyrate. *FEMS Microbiol Rev* 103:251–256
- Hromatka O, Ebner H (1949) Investigations on vinegar fermentation: generator for vinegar fermentation and aeration procedures. *Enzymologia* 13:369
- Huang Y, Yang ST (1998) Acetate production from whey lactose using co-immobilized cells of homolactic and homoacetic bacteria in a fibrous-bed bioreactor. *Biotechnol Bioeng* 60:498–507
- Huang YL, Mann K, Mavak JM (1998) Acetic acid production from fructose by *Clostridium formicaceticum* immobilized in a fibrous bed bioreactor. *Biotechnol Prog* 14:800–806
- Inskeep GC, Taylor GG, Breitzke WC (1952) Lactic acid from corn sugar. *Ind Eng Chem* 44:1955–1966
- Isbell HS, Frush HL, Bates FJ (1932) Manufacture of calcium gluconate by electrolytic oxidation of glucose. *Ind Eng Chem* 24:375–378
- Ishizaki A, Taga N, Takeshita T, Sugimoto T, Tsuge T, Tanaka K (1997) Microbial production of biodegradable plastics from carbon dioxide and agricultural waste material. In: Saha BC, Woodward J (eds) Fuels and chemicals from biomass. American Chemical Society, Washington, DC, pp 295–306
- Iversen T-G, Standal R, Pederson T, Caucheron DH (1994) IS 1032 from *Acetobacter xylinum*, a new mobile insertion sequence. *Plasmid* 32:46–54
- Jabalquinto AM, Laivenieks M, Zeikus JG, Cardemil E (1999) Characterization of the oxaloacetate decarboxylase and pyruvate kinase-like activities of *Saccharomyces cerevisiae* and *Anaerobiospirillum succiniciproducens* phosphoenolpyruvate carboxykinases. *J Prot Chem* 18:659–664
- Jarvis L (2001) Lactic acid outlook up as polylactide nears market. *Chem Mark Repor* 259(9) 5, 14
- Jendrossek D, Backhaus M, Andermann M (1995) Characterization of the *Comamonas* sp. poly(3-hydroxybutyrate) (PHB) depolymerase and of its structural gene. *Can J Microbiol* 41:160–169
- Jendrossek D, Schirmer A, Schlegel HG (1996) Biodegradation of polyhydroxyalkanoic acids. *Appl Microbiol Biotechnol* 46:451–463
- John ME, Keller G (1996) Metabolic pathway engineering in cotton: biosynthesis of polyhydroxybutyrate in fiber cells. *Proc Natl Acad Sci USA* 93:12768–12773
- Jones RP, Greenfield P (1982) Effect of carbon dioxide on yeast growth and fermentation. *Enz Microbiol Technol* 4:210–223
- Jossek R, Steinbüchel A (1998) In vitro synthesis of poly-(3-hydroxybutyric acid) by using an enzymatic coenzyme A recycling system. *FEMS Microbiol Lett* 168:319–324
- Kandler O, Weiss N (1986) In: Sneath PHA, Mair NS, Sharpe ME, Holt JG (eds) Bergey's manual of systematic bacteriology, vol 2. Williams & Wilkins, Baltimore, pp 1208–1234, <http://www.cme.msu.edu/bergeys>
- Kaneuchi C, Seki M, Komagata K (1988) Production of succinic acid from citric acid and related acids by *Lactobacillus* strains. *Appl Environ Microbiol* 54:3053–3056
- Kansiz M, Billman-Jacobe H, McNaughton D (2000) Quantitative determination of the biodegradable polymer poly(β -hydroxybutyrate) in a recombinant *Escherichia coli* strain by use of mid-infrared spectroscopy and multivariate statistics. *Appl Environ Microbiol* 66:3415–3420
- Kawaguchi Y, Doi Y (1990) Structure of native poly(3-hydroxybutyrate) granules characterized by X-ray diffraction. *FEMS Microbiol Lett* 70:151–156
- Kawaguchi Y, Doi Y (1992) Kinetics and mechanism of synthesis and degradation of poly(3-hydroxybutyrate) in *Alcaligenes eutrophus*. *Macromolecules* 25:2324–2329
- Kennedy JF, Humphreys JD, Barker SA, Greenshields RN (1980) Application of living immobilized cells to the acceleration of the continuous conversions of ethanol (wort) to acetic acid (vinegar) by hydrous titanium (IV) oxide-immobilized *Acetobacter* species. *Enz Microbiol Technol* 2:209–216

- Kim DM, Kim HS (1992) Continuous production of gluconic acid and sorbitol from Jerusalem artichoke and glucose using an oxido reductase from *Zymomonas mobilis* and inulinase. *Biotechnol Bioeng* 39:336–342
- Kim BS, Lee SY, Chang HN (1992) Production of poly-beta-hydroxybutyrate by fed-batch culture of recombinant *Escherichia coli*. *Biotechnol Lett* 14:811–816
- Kim BS, Lee SY, Chang HN, Chang YK, Woo SI (1994) Production of poly(3-hydroxybutyric acid) by fed-batch culture of *Alcaligenes eutrophus* with glucose concentration control. *Biotechnol Bioeng* 43:892–898
- Kim SW, Kim P, Lee HS, Kim JH (1996) High production of poly-beta-hydroxybutyrate (PHB) from *Methylobacterium organophilum* under potassium limitation. *Biotechnol Lett* 18:25–30
- Kim GJ, Lee IY, Yoon SC, Shih YC, Park YH (1997) Enhanced yield and a high production of medium-chain-length poly(3-hydroxyalkanoates) in a two-step fed-batch cultivation of *Pseudomonas putida* by combined use of glucose and octanoate. *Enz Microb Technol* 20:500–505
- Kirschner EM (1996) Growth of top 50 chemicals slowed from very high 1994 rate. *Chem Eng News* 74(15):16–19
- Klaenhammer TR, Fitzgerald GF (1994) Bacteriophages and bacteriophage resistance. In: Gasson MJ, DeVos WM (eds) *Genetics and biotechnology of lactic acid bacteria*. Blackie Academic/Professional Publishers, London/New York, pp 106–168
- Klinke S, de Roo G, Witholt B, Kessler B (2000) Role of phaD in accumulation of medium-chain-length poly(3-hydroxyalkanoates) in *Pseudomonas oleovorans*. *Appl Environ Microbiol* 66:3705–3710
- Knauf HJ, Vogel RF, Hammes WP (1992) Cloning, sequence, and phenotypic expression of KatA which encodes the catalase of *Lactobacillus sake* LTH677. *Appl Environ Microbiol* 58:832–839
- Kok J, DeVos JM (1994) The proteolytic system of lactic acid bacteria. In: Gasson MJ, DeVos WM (eds) *Genetics and biotechnology of lactic acid bacteria*. Blackie Academic/Professional Publishers, London, New York, pp 169–210
- Kondo K, Horinouchi S (1997) A new insertion sequence IS 1452 from *Acetobacter pasteurianus*. *Microbiology* 143:539–546
- Kosaric N (1996) Ethanol-potential source of energy and chemical products. In: Rehm HJ, Reed G (eds) *Biotechnology*, vol 6. VCH, New York, pp 123–203
- Kutzing FT (1837) *Prakt Chem J* 11:385
- Kwon YJ, Kaol R, Mattiasson B (1996) Extractive lactic acid fermentation in poly(ethyleneimine)-based aqueous two-phase system. *Biotechnol Bioeng* 50:280–290
- Laivenieks M, Vielle C, Zeikus JG (1997) Cloning, sequencing, and overexpression of the *Anaerobiospirillum succiniciproducens* phosphoenolpyruvate carboxykinase (pckA) gene. *Appl Environ Microbiol* 63:2272–2280
- Landucci R, Goodman B, Wyman C (1994) Methodology for evaluating the economics of biologically producing chemicals and materials from alternative feedstocks. *Appl Biochem Biotechnol* 45/46:677–696
- Layman P (1998) Acetic acid industry gears up for possible building boom. *Chem Eng News* 76(31):17–18
- Leaf TA, Peterson MS, Stoup SK, Somers D, Srienc F (1996) *Saccharomyces cerevisiae* expressing bacterial polyhydroxybutyrate synthase produces poly-3-hydroxybutyrate. *Microbiol* 142:1169–1180
- Lee SY (1996a) Bacterial polyhydroxyalkanoates. *Biotechnol Bioeng* 49:1–14
- Lee SY (1996b) Plastic bacteria? Progress and prospects for polyhydroxyalkanoate production in bacteria. *Trends Biotechnol* 14:431–438
- Lee SY (1997) *E. coli* moves into the plastic age. *Nat Biotechnol* 15:17–18
- Lee SY, Chang HN (1995a) Production of poly(hydroxyalkanoic acid). *Adv Biochem Eng Biotechnol* 52:27–58
- Lee SY, Chang HN (1995b) Production of poly(3-hydroxybutyric acid) by recombinant *Escherichia coli* strains: genetic and fermentation studies. *Can J Microbiol* 41(Suppl 1):207–215
- Lee SY, Lee YK, Chang HN (1995) Stimulatory effects of amino acids and oleic acid on poly(3-hydroxybutyric acid) synthesis by recombinant *Escherichia coli*. *J Ferment Bioeng* 79:177–180
- Lee IY, Kim MK, Park YH, Lee SY (1996) Regulatory effects of cellular nicotinamide nucleotides and enzyme activities on poly(3-hydroxybutyrate) synthesis in recombinant *Escherichia coli*. *Biotechnol Bioeng* 52:707–712
- Lee PC, Lee WG, Kwon S, Lee SY, Chang HN (1999a) Succinic acid production by *Anaerobiospirillum succiniciproducens*: effects of the H₂/CO₂ supply and glucose concentration. *Enz Microbiol Technol* 24:549–554
- Lee PC, Lee WG, Lee SY, Chang HN (1999b) Effects of medium components on the growth of *Anaerobiospirillum succiniciproducens* and succinic acid production. *Proc Biochem* 35:49–55
- Lee SY, Lee Y, Wang FL (1999c) Chiral compounds from bacterial polyesters: sugars to plastics to fine chemicals. *Biotechnol Bioeng* 65:363–368
- Leh MB, Charles M (1989) The effect of whey protein hydrolyzate average molecular weight on the lactic acid fermentation. *J Ind Microbiol* 4:77–80
- Leigh JA, Mayer F, Wolfe RS (1981) *Acetogenium kivui* a new thermophilic hydrogen-oxidizing, acetogenic bacterium. *Arch Microbiol* 129:275–280
- Lemoigne M (1925) Etudes sur l'autolyse microbienne acidification par formation d'acide β-oxybutyrique. *Ann Inst Pasteur* 39:144–173
- Lemoigne M (1926) Produits de déshydratation et de polymérisation de l'acide β-oxybutyrique. *Bull Soc Chim Biol* 8:770–782
- Lemoigne M, Girard H (1943) Réserves lipidiques β-hydroxybutyriques chez *Azotobacter chroococcum*. *Comp Rend Acad Sci* 217:557–558
- Liebesgesell M, Husted E, Timm A, Steinbüchel A, Fuller RC, Lenz RW, Schlegel HG (1991) Formation of poly(3-hydroxyalkanoates) by phototrophic and chemolithotrophic bacteria. *Arch Microbiol* 155:415–421
- Lin RW, Atkinson EE, Balhoff DE (1996) Process for producing (S,S)-ethylenediamine-N,N'-disuccinic acid. US Patent 5554791
- Lin M-Y, Harlander S, Saviano D (1999) Construction of an integrative food-grade cloning vector for *Lactobacillus acidophilus*. *Appl Microb Biotechnol* 45:484–489
- Lipinsky ES, Sinclair RG (1986) Is lactic acid a commodity chemical? *Chem Eng Prog* 82(8):26–32
- Litchfield JH (1996) Microbial production of lactic acid. *Adv Appl Microbiol* 42:45–95
- Liu S-J, Steinbüchel A (2000a) Exploitation of butyrate kinase and phosphotransbutyrylase from *Clostridium acetobutylicum* for the in vitro biosynthesis of poly(hydroxyalkanoic acid). *Appl Microbiol Biotechnol* 53:545–552
- Liu S-J, Steinbüchel A (2000b) A novel genetically engineered pathway for synthesis of poly(hydroxyalkanoic acids) in *Escherichia coli*. *Appl Environ Microbiol* 66:739–743
- Ljungdahl LG (1986) The autotrophic pathway of acetate synthesis in acetogenic bacteria. *Ann Rev Microbiol* 40:415–450
- Ljungdahl LG (1994) The acetyl-CoA pathway and the chemiosmotic generation of ATP during acetogenesis. In: Drake HL (ed) *Acetogenesis*. Chapman and Hall, New York, pp 63–85
- Lockwood LB, Yoder DE, Zienty M (1965) Lactic acid. *Ann NY Acad Sci* 119:854–867
- Loos H, Krämer R, Sahn H, Sprenger GA (1994) Sorbitol promotes growth of *Zymomonas mobilis* in environment with high concentrations of sugar: evidence for a physiological function of glucose-fructose oxidoreductase in osmoprotection. *J Bacteriol* 176:7688–7693
- Lorowitz WH, Bryant MP (1984) Peptostreptococcus productus strain that grows rapidly with CO as an energy source. *Ann Environ Microbiol* 47:961–964
- Luchansky JB, Muriana PM, Klaenhammer TR (1988) Application of electroporation for transfer of plasmid DNA to *Lactobacillus*, *Lactococcus*, *Leuconostoc*, *Listeria*, *Pediococcus*, *Bacillus*, *Staphylococcus*, *Enterococcus*, and *Propionibacterium*. *Molec Microbiol* 2:637–646
- Luttik MAH, Van Spanning R, Schipper D, Van Dijken JP, Pronk JT (1997) The low biomass yields of the acetic acid bacterium *Acetobacter pasteurianus* are due to a low stoichiometry of respiration-coupled proton translocation. *Appl Environ Microbiol* 63:3345–3351
- Maddox IS (1996) Microbial production of 2, 3-butanediol. In: Rehm HJ, Reed G (eds) *Biotechnology*, vol 6, 2nd edn. VCH, New York, pp 270–291
- Madison LL, Huisman GW (1999) Metabolic engineering of poly(3-hydroxyalkanoates): from DNA to plastic. *Microbiol Molec Biol Rev* 63:21–53
- Martin MC, Alonso JC, Suarez JE, Alvarez MA (2000) Generation of food-grade recombinant lactic acid bacterium strains by site-specific recombination. *Appl Environ Microbiol* 66:2599–2604
- Mat-Jan F, Alam KY, Clark DP (1989) Mutants of *Escherichia coli* deficient in the fermentative lactate dehydrogenase. *J Bacteriol* 171:342–348

- Matsusaki H, Abe H, Taguchi K, Fukui T, Doi Y (2000) Biosynthesis of poly (3-hydroxybutyrate-co-3-hydroxyalkanoates) by recombinant bacteria expressing the PHA synthase gene *phaC1* from *Pseudomonas* sp. 61-3. *Appl Microbiol Biotechnol* 53:401–409
- Matsushita K, Toyama H, Adachi O (1994) Respiratory chains and bioenergetics of acetic acid bacteria. *Adv Microb Physiol* 36:247–301
- May OE, Herrick HT, Moyer AJ, Wells PA (1934) Gluconic acid-production by submerged mold growths under increased air pressure. *Ind Eng Chem* 26:575–578
- McCoy M (1998) Biomass ethanol inches forward. *Chem Eng News* 76:29–32
- McGee H (1984) On food and cooking: the science and lore of the kitchen. Scribner, New York, p 36
- Mercier P, Yerushalmi L, Rouleau D, Dochain D (1992) Kinetics of lactic acid fermentation on glucose and corn by *Lactobacillus amylophilus*. *J Chem Tech Biotechnol* 55:111–121
- Mesa MM, Caro I, Cantero D (1996) Viability reduction of *Acetobacter aceti* due to the absence of oxygen in submerged culture. *Biotech Progr* 12:709–712
- Millard CS, Chao YP, Liao JC, Donnelly MI (1996) Enhanced production of succinic acid by overexpression of phosphoenolpyruvate carboxylase in *Escherichia coli*. *Appl Env Microbiol* 62:1808–1810
- Milson PE, Meers JL (1985) Gluconic and itaconic acids. In: Moo-Young M (ed) *Comprehensive biotechnology*, vol 3. Pergamon, Oxford, pp 681–700
- Misoph M, Drake HL (1996) Effect of CO₂ on the fermentation capacities of the acetogen *Peptostreptococcus productus* U-1. *J Bacteriol* 178:3140–3145
- Mobley DP (1994) *Plastics from microbes*. Hanser, Munich
- Möller B, Ossmer R, Howard BH, Gottschalk G, Hippe H (1984) *Sporomusa*, a new genus of Gram negative anaerobic bacteria including *Sporomusa sphaeroides* spec. nov. and *Sporomusa ovata* spec. nov. *Arch Microbiol* 139:388–396
- Molliard M (1922) Survenue nouvelle fermentation acide produite par le *Sterigmatocystis nigra*. *CR Hebd Seances Acad Sci* 174:881–883
- Mori A (1993) Vinegar production in a fluidized-bed reactor with immobilized bacteria. In: Tanaka A, Tosa T, Kobayashi T (eds) *Industrial application of immobilized biocatalysts*. Dekker, New York, pp 291–313
- Mori A, Tervi G (1972) Kinetic studies on submerged acetic acid fermentation. III: efficiency of energy metabolism in acetic acid fermentation using *Acetobacter rancens*. *J Ferment Technol* 50:510–517
- Moyer AJ, Wells PA, Stubbs JJ, Herrick HT, May OE (1937) Gluconic acid production-development of inoculum and composition of fermentation solution for gluconic acid production by submerged mold growths under increased air pressure. *Ind Eng Chem* 29:777–781
- Müller V, Gottschalk G (1994) The sodium ion cycle in acetogenic and methanogenic bacteria: generation and utilization of a primary electrochemical sodium ion gradient. In: Drake HL (ed) *Acetogenesis*. Chapman and Hall, New York, pp 125–156
- Muller HM, Seebach D (1993) Poly(hydroxyfettsaureester) eine funfte Klasse von physiologisch bedeutsamen organischen Biopolymeren? *Angew Chem* 105:483–459
- Muraoka H, Watabe Y, Ogasawara N (1982) Effect of oxygen deficiency on acid production and morphology of bacterial cells in submerged acetic fermentation by *Acetobacter aceti*. *J Ferment Technol* 60:171–180
- Narayan R (1994) Impact of governmental policies, regulations, and standards activities on an emerging biodegradable plastics industry. In: Doi Y, Fukuda K (eds) *Biodegradable plastics and polymers*. Elsevier Science, Amsterdam, pp 261–272
- Nawrath C, Poirier Y, Somerville C (1994) Targeting of the polyhydroxybutyrate biosynthetic pathway to the plastids of *Arabidopsis thaliana* results in high levels of polymer accumulation. *Proc Natl Acad Sci USA* 91:12760–12764
- Nghiem NP, Davison BH, Thompson JE, Suttle BE, Richardson GR (1996) The effect of biotin on the production of succinic acid by *Anaerobiospirillum succiniciproducens*. *Appl Biochem Biotechnol* 57/58:633–638
- Nghiem NP, Davison BH, Suttle BE, Richardson GR (1997) Production of succinic acid by *Anaerobiospirillum succiniciproducens*. *Appl Biochem Biotechnol* 63–65:565–576
- Nghiem NP, Donnelly MI, Millard CS (1999) Method for the production of dicarboxylic acids. US Patent 5,869,301
- Nickol GB (1979) Vinegar. In: Pepler HJ, Pearlman D (eds) *Microbial technology*, vol 2. Academic, New York, pp 155–172
- Nidetzky B, Furlinger M, Gollhofer D (1997) Improved operational stability of cell-free glucose-fructose oxidoreductase from *Zymomonas mobilis* for the efficient synthesis of gluconic acid and sorbitol, in acoutin ultra filtration membrane reactor. *Biotechnol Bioeng* 53:623–629
- Nishioka M, Tuzuki T, Wanajyo Y, Oonami H, Horiuchi T (1994) Biodegradation of Bionolle. *Stud Polym Sci* 12:584–590
- Noury M, van der Lande NV (1962) Process for preparation of gluconic acid monohydrate. British Patent 902609. *Chem Abstr* 57:13020g
- Oben JM, Amagro MJ, Manjon A (1996) Continuous retention of native NADP(H) in an enzyme membrane reactor for gluconate and glutamate production. *J Biotechnol* 50:27–36
- Okumura H, Tagami H, Fukaya M, Masai H, Kawamura Y, Horinouchi S, Beppu T (1988) Cloning of the β -isopropylmalate dehydrogenase gene from *Acetobacter aceti* and its use for construction of a new host vector system for *Acetobacter*. *Agric Biol Chem* 52:3125–3129
- Olijve W, Kok JJ (1979) Analysis of growth of *Gluconobacter oxydans* in glucose containing medium. *Arch Microbiol* 121:283–290
- Osuga J, Mori A, Kato J (1984) Acetic acid production by immobilized *Acetobacter aceti* cells entrapped in a kappa-carrageenan gel. *J Ferment Technol* 62:139–149
- Othmer K (1983) Succinic acid and succinic anhydride. In: Othmer K (ed) *Encyclopedia of chemical technology*, 3rd edn, vol 21, Wiley, pp 848–864
- Page WJ, Cornish A (1993) Growth of *Azotobacter vinelandii* UWD in fish peptone medium and simplified extraction of poly-beta-hydroxybutyrate. *Appl Environ Microbiol* 59:4236–4244
- Pan JG, SooSA, Park CK, Kim P, Chang DE, Kim JE (1999) A *pta* *ldhA* double mutant *Escherichia coli* SS373 and the method of producing succinic acid therefrom. PCT Application WO 99/06532
- Parekh SR, Cheryan M (1991) Production of acetate by mutant strains of *Clostridium thermoaceticum*. *Appl Microbiol Biotechnol* 36:384–387
- Parekh SR, Cheryan M (1994a) Continuous production of acetate by *Clostridium thermoaceticum* in a cell-recycle membrane bioreactor. *Enz Microb Technol* 16:104–109
- Parekh SR, Cheryan M (1994b) High concentrations of acetate with a mutant strain of *Clostridium thermoaceticum*. *Biotechnol Lett* 16:139–142
- Park DH, Zeikus GK (1999) Utilization of electrically reduced neutral red by *Actinobacillus succinogenes*: physiological function of neutral red in membrane-driven fumarate reduction and energy conservation. *J Bacteriol* 181:2403–2410
- Park YS, Ohtake H, Fukaya M, Okumura H, Kawamura Y, Toda K (1989) Acetic acid production using a fermenter equipped with a hollow fiber filter module. *Biotechnol Bioeng* 33:918–923
- Park YS, Ohtake H, Fukaya M, Kawamura H, Toda K (1991) Production of high concentration of acetic acid by *Acetobacter aceti* using a repeated fed-batch culture with cell recycling. *Appl Microbiol Biotechnol* 35:149–153
- Parrer G, Schroll G, Gapes JR, Lubitz W, Schuster KC (2000) Conversion of solvent evaporation residues from the AB-(acetone-butanol) bioprocess into bacterial cells accumulating thermoplastic polyesters. *J Molec Microbiol Biotechnol* 2:81–86
- Pasteur L (1868) Etudes sur le vinaigre, sa fabrication se maladres, moyens de les préveair nouvelles observations sur la conservation des vinc par la châlure. Gauthier-Villars, Paris
- Peoples OP, Sinskey AJ (1987) Biosynthetic thiolase from *Zoogloea ramigera* III: isolation and characterization of the structural gene. *J Biol Chem* 262:97–102
- Peoples OP, Sinskey AJ (1989) Poly- β -hydroxybutyrate biosynthesis in *Alcaligenes eutrophus* H16: characterization of the genes encoding β -ketothiolase and acetoacetyl-CoA reductase. *J Biol Chem* 264:15293–15297
- Phillips MA (1963) Catalytic hydrogenation of glucose to sorbitol using a highly active catalyst. *Br Chem Eng* 8(11):767–769
- Planas J, Radström P, Tjerneld F, Hahn-Hägerdal B (1996) Enhanced production of lactic acid through the use of a novel aqueous two-phase system as an extractive fermentation system. *Appl Microbiol Biotechnol* 45:737–743

- Podkovyrov SM, Zeikus JG (1993) Purification and characterization of phosphoenolpyruvate carboxykinase, a catabolic CO₂-fixing enzyme, from *Anaerobiospirillum succiniciproducens*. J Gen Microbiol 139:223–228
- Poehland HD, Schierz V, Schumann R (1993) Optimization of gluconic acid synthesis by removing limitations and inhibitions. Acta Biotechnol 13:257–268
- Poirier Y, Dennis DE, Klomparens K, Somerville C (1992) Polyhydroxybutyrate, a biodegradable thermoplastic, produced in transgenic plants. Science 256:520–522
- Poirier Y, Nawrath C, Somerville C (1995) Production of polyhydroxyalkanoates, a family of biodegradable plastics and elastomers, in bacteria and plants. Bio/technology 13:142–150
- Posno M, Heuvelmans PTHM, van Giezen MJF, Lokman BC, Leer RJ, Pouwels PH (1991) Complimentation of the inability of *Lactobacillus strains* to utilize D-xylose with D-xylose catabolism-encoding genes of *Lactobacillus pentosus*. Appl Environ Microbiol 57:2764–2766
- Pries A, Steinbüchel A, Schlegel HG (1990) Lactose-utilizing and galactose-utilizing strains of poly(hydroxyalkanoic acid)-accumulating *Alcaligenes eutrophus* and *Pseudomonas saccharophila* obtained by recombinant DNA technology. Appl Microbiol Biotechnol 33:410–417
- Prieto MA, Buhler B, Jung K, Witholt B, Kessler B (1999a) PhaE, a polyhydroxyalkanoate-granule-associated protein of *Pseudomonas oleovorans* GPo1 involved in the regulatory expression system for pha genes. J Bacteriol 181:858–868
- Prieto MA, Kellerhals MB, Bozzato GB, Radnovic D, Witholt B, Kessler B (1999b) Engineering of stable recombinant bacteria for production of chiral medium-chain-length poly-3-hydroxyalkanoates. Appl Environ Microbiol 65:3265–3271
- Pronk JT, Levering PR, Olijve W, Van Dijken JP (1989) The role of NADP-dependent and quino protein glucose dehydrogenase in gluconic acid production by *Gluconobacter oxydans*. Enz Microb Technol 11:160–164
- Ragsdale SW (1994) CO dehydrogenase and the central role of this enzyme in fixation of carbon-dioxide by anaerobic bacteria. In: Drake HL (ed) Acetogenesis. Chapman and Hall, New York, pp 88–126
- Rehm BHA, Kruger N, Steinbüchel A (1998) A new metabolic link between fatty acid de novo synthesis and polyhydroxyalkanoic acid synthesis. J Biol Chem 273:24044–24051
- Rehr B, Wilhelm C, Sahn H (1991) The production of sorbitol and gluconic acid by permeabilized cells of *Zymomonas mobilis*. Appl Microbiol Biotechnol 35:144–148
- Reisch MS (1999) Vision 2020 comes into focus. Chem Eng News 77(32):10–12
- Ren Q, Sierro N, Kellerhals M, Kessler B, Witholt B (2000) Properties of engineered poly-3-hydroxyalkanoates produced in recombinant *Esherichia coli* strains. Appl Environ Microbiol 66:1311–1320
- Reusch RN (1992) Biological complexes of poly-β-hydroxybutyrate. FEMS Microbiol Rev 103:119–130
- Reusch RN, Sadoff HL (1988) Putative structure and functions of a poly-β-hydroxybutyrate/calcium polyphosphate channel in bacterial plasma membranes. Proc Natl Acad Sci USA 85:4176–4180
- Reusch RN, Sparrow A (1992) Transport of poly-β-hydroxybutyrate in human plasma. Biochim Biophys Acta 1123:33–40
- Ro HS, Kim HS (1991) Continuous production of gluconic acid and sorbitol from sucrose using invertase and an oxidoreductase from *Zymomonas mobilis*. Enz Microb Technol 13:920–924
- Roehr M, Kubicek CP, Kominek J (1996) Gluconic acid. In: Roehr M (ed) Biotechnology, 2nd edn. VCH, New York, pp 348–362
- Saeki A, Taniguchi M, Matsushita K, Yoyama H, Theeragol G, Lotong N, Adachi O (1997a) Microbial aspects of acetate oxidation by acetic acid bacteria, unfavorable phenomena in vinegar fermentation. Biosci Biotech Biochem 61:317–323
- Saeki A, Theeragol G, Matsushita K (1997b) Development of thermotolerant acetic acid bacteria useful for vinegar fermentation at high temperature. Biosci Biotech Biochem 61:138–145
- Sakura H, Lee HW, Sato S, Mukataka S, Takahashi J (1989) Gluconic acid production by *Aspergillus niger* immobilized on nonwoven fabric. J Ferment Bioeng 67:404–408
- Samuelov NS, Lamed R, Lowe S, Zeikus JG (1991) Influence of CO₂-HCO₃-levels and pH on growth, succinate production, and enzyme activities of *Anaerobiospirillum succiniciproducens*. Appl Environ Microbiol 57:3013–3019
- Samuelov NS, Datta R, Jain MK, Zeikus JG (1999) Whey fermentation by *Anaerobiospirillum succiniciproducens* for production of a succinate-based animal feed additive. Appl Environ Microbiol 65:2260–2263
- Scheirlinck T, Mahillon J, Joos H, Dahaese P, Michiels F (1989) Integration and expression of α-amylase and endoglucanase genes in the *Lactobacillus plantarum* chromosome. Appl Environ Microbiol 55:2130–2137
- Schilling LB (1995) Chemicals from alternative feedstocks in the United States. FEMS Microbiol Rev 16:101–110
- Schlegel HG, Gottschalk G, Von Vartha R (1961) Formation and utilization of poly-β-hydroxybutyric acid by Knallgas bacteria (*Hydrogenomonas*). Nature 191:463–465
- Schubert P, Steinbüchel A, Schlegel HG (1988) Cloning of the *Alcaligenes eutrophus* gene for synthesis of poly-β-hydroxybutyric acid and synthesis of PHB in *Escherichia coli*. J Bacteriol 170:5837–5847
- Senthuran A, Senthuran V, Mathasson B, Kaul R (1997) Lactic acid fermentation in a recycle batch reactor using immobilized *Lactobacillus casei*. Biotechnol Bioeng 55:841–853
- Shah MM, Cheryan M (1995a) Acetate production by *Clostridium thermoaceticum* in corn steep liquor media. J Ind Microbiol 15:424–428
- Shah MM, Cheryan M (1995b) Improvement of productivity in acetic acid fermentation with *Clostridium thermoaceticum*. Appl Biochem Biotechnol 51/52:418–422
- Shiraishi F, Kawakami K, Kono S, Tamura A (1989a) Continuous production of free gluconic acid by *Gluconobacter suboxydans* IFO 3290 immobilized by adsorption on ceramic honeycomb monolith: effect of reactor configuration on further oxidation of gluconic acid to ketogluconic acid. Appl Microbiol Biotechnol 31:445–447
- Shiraishi F, Kawakami K, Kono S, Tamura A, Tsuruta S, Kosmoki K (1989b) Characterization of production of free gluconic acid by *Gluconobacter suboxydans* adsorbed on ceramic honeycomb monolith. Biotechnol Bioeng 33:1413–1418
- Sievers M, Sellmer S, Teuber M (1992) *Acetobacter europaeus* sp. nov., a main component of industrial vinegar fermenters in central Europe. Syst Appl Microbiol 15:386–392
- Sievers M, Ludwig W, Teuber M (1994a) Phylogenetic positioning of *Acetobacter*, *Gluconobacter*, *Rhodophila*, and *Acidiphilium* species as a branch of acidophilic bacteria in the α-subclass of proteobacteria based on 16S ribosomal DNA sequences. Syst Appl Microbiol 17:189–196
- Sievers M, Ludwig W, Teuber M (1994b) Phylogenetic positioning of *Acetobacter*, *Gluconobacter*, *Rhodophila* and *Acidiphilium* species as a branch of acidophilic bacteria in the α subclass of Proteobacteria based on 16S RNA sequences. Syst Appl Microbiol 17:352–354
- Sievers M, Ludwig W, Teuber M (1994c) Revival of the species *Acetobacter methanolicus* (ex: Uhlig et al., 1986) nom. rev. Syst Appl Microbiol 17:352–354
- Silva-Martinez M, Haltrich D, Novalic S, Kobe KD, Nidetzky B (1998) Simultaneous enzymatic syntheses of gluconic acid and sorbitol. Appl Biochem Biotechnol 70–72:863–875
- Silveira MM, Wisbeck E, Lemmel C (1999) Bioconversion of glucose and fructose to sorbitol and gluconic acid by untreated cells of *Zymomonas mobilis*. J Biotechnol 75:99–103
- Slater S, Houmiel KL, Tran M, Mitsky TA, Taylor NB, Padgett SR, Gruys KJ (1998) Multiple β-ketothiolase mediate poly(β-hydroxyalkanoate) copolymer synthesis in *Ralstonia eutropha*. J Bacteriol 180:1979–1987
- Slater S, Mitsky TA, Houmiel KL, Hao M, Reiser SE, Taylor NB, Tran M, Valentin HE, Rodriguez J, Stone DA, Padgett SR, Kishore G, Gruys KJ (1999) Metabolic engineering of Arabidopsis and Brassica for poly(3-hydroxybutyrate-co-3-hydroxyvalerate) copolymer production. Nat Biotechnol 17:1011–1016
- Smith WP (1993) Soap/Cosmetic Specialties 9:54–58
- Sokollek SJ, Hammes WP (1997) Description of a starter culture preparation for vinegar fermentation. Syst Appl Microbiol 20:481–491

- Sokollek SJ, Hertel C, Hammes WP (1998) Cultivation and preservation of vinegar bacteria. *J Biotechnol* 60:195–206
- Steinbüchel A (1991) Polyhydroxyalkanoic acids. In: Byrom D (ed) *Biomaterials: novel materials from biological sources*. Macmillan, New York
- Steinbüchel A (1996) PHB and other polyhydroxyalkanoic acids. In: Roehr M (ed) *Biotechnology*, vol 6, 2nd edn. VCH, Weinheim, pp 403–464
- Steinbüchel A, Fuchtenbusch B (1998) Bacterial and other biological systems for polyester production. *Trends Biotechnol* 16:419–427
- Steinbüchel A, Gorenflo V (1997) Biosynthetic and biodegradable polyesters from renewable resources: current state and prospects. *Macromol Symp* 123:61–66
- Steinbüchel A, Schmack G (1995) Large-scale production of poly(3-hydroxyvaleric acid) by fermentation of *Chromobacterium violaceum*, processing, and characterization of the homopolyester. *J Environ Polym Degrad* 3:243–258
- Stols L, Donnelly MI (1997) Production of succinic acid through overexpression of NAD⁺-dependent malic enzyme in an *Escherichia coli* mutant. *Appl Environ Microbiol* 63:2695–2701
- Stols L, Kulkarni G, Harris BG, Donnelly MI (1997) Expression of *Ascaris suum* malic enzyme in a mutant *Escherichia coli* allows production of succinic acid from glucose. *Appl Biochem Biotechnol* 63–65:153–158
- Suzuki T, Yamane T, Shimizu S (1986) Mass production of poly-β-hydroxybutyric acid by fed-batch culture with controlled carbon/nitrogen feeding. *Appl Microbiol Biotechnol* 24:370–374
- Swings J (1992) The genera acetobacter and gluconobacter. In: Balows A, Trüper HG, Dworkin M, Harder W, Schleifer KH (eds) *The prokaryotes*, vol 3. Springer, New York, pp 2268–2286, <http://www.prokaryotes.com>
- Swings J, De Ley J (1977) The biology of *Zymomonas*. *Bacteriol Rev* 41:1–46
- Szmant HH (1989) *Organic building blocks of the chemical industry*. Wiley, New York, pp 347–348
- Taguchi H, Ohata T (1991) D-Lactate dehydrogenase is a member of the D-isomer-specific 2-hydrox acid dehydrogenase family. *J Biol Chem* 266:12588–12594
- Takahashi R, Fujimoto N, Suzuki M, Endo T (1997) Biodegradabilities of ethylenediamine-N, N-disuccinic acid (EDDS) and other chelating agents. *Biosci Biotech Biochem* 61:1957–1959
- Takemura H, Horinouchi S, Beppu T (1991) Novel insertion sequence IS1380 from *Acetobacter pasteurianus* is involved in loss of ethanol-oxidizing ability. *J Bacteriol* 173:7070–7076
- Takiyama E, Fujimaki T (1994) “BIONELLE” biodegradable plastic through chemical synthesis. In: Doi Y, Fukuda K (eds) *Biodegradable plastics and polymers*. Elsevier Science, Amsterdam, pp 150–174
- Tanaka K, Ishizaki A, Kanamaru T, Kawano T (1995) Production of poly(D-3-hydroxybutyrate) from CO₂, H₂, and O₂ by high cell-density autotrophic cultivation of *Alcaligenes eutrophus*. *Biotechnol Bioeng* 45:268–275
- Taroncher-Oldenburg G, Nishia K, Stephanopoulos G (2000) Identification and analysis of polyhydroxyalkanoate-specific β-ketothiolase and acetoacetyl coenzyme A reductase genes in cyanobacterium *Synechocystis* sp. strain PCC6803. *Appl Environ Microbiol* 66:4440–4448
- Thauer RK (1989) Biochemistry of acetic acid metabolism in anaerobic chemotrophic bacteria. *Ann Rev Microbiol* 43:43–67
- Toda K, Park YS, Asakura T, Cheng CY, Ohtake H (1989) High rate acetic acid production in a shallow flow bioreactor. *Appl Microbiol Biotechnol* 30:559–563
- Tsai SP, Moon S-H (1998) An integrated bioconversion process for the production of L-lactic acid from starchy potato feed stocks. *Appl Biochem Biotechnol* 70–72:417–428
- Tsao GT, Cao NJ, Du J, Gong CS (1999) Production of multifunctional organic acids from renewable resources. *Adv Biochem Eng Biotechnol* 65:243–280
- Tullo A (1999) BDO market embraces new technologies. *Chemical Market Reporter* 26 April 1999
- Turk R (1993) Metal free and low metal salt substitutes containing lysine. US Patent 5229161
- Uhlig H, Kahrbaum K, Steudel A (1986) *Acetobacter methanolicus* sp. nov., an acetophilic facultatively methylotrophic bacterium. *Int J Syst Bacteriol* 36:317–322
- Valentin HE, Mitsky TA, Mahadeo DA, Tran M, Gruys KJ (2000a) Application of a propionyl coenzyme A synthetase for poly(3-hydroxypropionate-co-3-hydroxybutyrate) accumulation in recombinant *Escherichia coli*. *Appl Environ Microbiol* 66:5253–5258
- Valentin HE, Reiser S, Gruys KJ (2000b) Poly(3-hydroxybutyrate-co-4-hydroxybutyrate) formation from γ-aminobutyrate and glutamate. *Biotechnol Bioeng* 67:291–299
- Van der Werf MJ, Guettler MV, Jain MK, Zeikus JG (1997) Environmental and physiological factors affecting the succinate product ratio during carbohydrate fermentation by *Actinobacillus* sp. 130Z. *Arch Microbiol* 167:332–342
- Varadarajan S, Miller DJ (1999) Catalytic upgrading of fermentation-derived organic acids. *Biotechnol Prog* 15:845–854
- Verhove TH (1930) Verfahren zur bakteriellen oxydation organischer Verbindungen zwecks Herstellungen von Oxydationsprodukten wie Dioxacton usw. German Patent 563,758. *Chem Abstr* 27:1085
- Vick Roy TB (1985) Lactic acid. In: Moo Young M (ed) *Comprehensive biotechnology*. Pergamon Press, Oxford/New York, pp 761–776
- Walker SA, Klaenhammer TR (2000) An explosive antisense RNA strategy for inhibition of a lactococcal bacteriophage. *Appl Environ Microbiol* 66:310–319
- Wang T-T, Lee BH (1997a) Plasmids in *Lactobacillus*. *Crit Rev Biotechnol* 17:227–272
- Wang FL, Lee SY (1997b) Poly(3-hydroxybutyrate) production with high productivity and high polymer content by a fed-batch culture of *Alcaligenes latus* under nitrogen limitation. *Appl Environ Microbiol* 63:3703–3706
- Wang F, Lee SY (1998) High cell density culture of metabolically engineered *Escherichia coli* for the production of poly(3-hydroxybutyrate) in a defined medium. *Biotechnol Bioeng* 58:325–328
- Wang X, Gong CS, Tsao GT (1998) Bioconversion of fumaric acid to succinic acid by recombinant *E. coli*. *Appl Biochem Biotechnol* 70–72:919–928
- Weusthuis RA, Huijberts GNM, Eggink G (1997) In: Eggink G, Steinbüchel A, Poirer Y, Witholt B (eds) *Proceedings of the 1996 international symposium on bacterial polyhydroxyalkanoates. Production for MCL-polyhydroxyalkanoates*. NRC Research Press, Davos, Switzerland, pp 102–109
- White D (1995) *The physiology and biochemistry of prokaryotes*. Oxford University Press, New York
- Wiegel J (1994) Acetate and the potential of homoacetogenic bacteria for industrial applications. In: Drake HL (ed) *Acetogenesis*. Chapman and Hall, New York, pp 484–504
- Wiegel J, Braun M, Gottschalk G (1981) *Clostridium thermoautotrophicum* species novum, a thermophile producing acetate from molecular hydrogen and carbon dioxide. *Curr Microbiol* 5:255–260
- Wilke D (1995) What should and what can biotechnology contribute to chemical bulk production? *FEMS Microbiol Rev* 16:89–100
- Wong HH, Lee SY (1998) Poly(3-hydroxybutyrate) production from whey by high density cultivation of recombinant *Escherichia coli*. *Appl Microbiol Biotechnol* 50:30–33
- Wood HG, Werkman CH (1938) The utilization of CO₂ by the propionic acid bacteria. *Biochem J* 32:1262–1271
- Wood HG, Werkman CH (1940) The relationship of bacterial utilization of CO₂ to succinic acid formation. *Biochem J* 34:129–138
- Xavier AMRB, Gonsalvas LMD, Moreira JL (1995) Operation patterns affecting lactic acid production in ultrafiltration cell recycle bioreactor. *Biotechnol Bioeng* 45:320–327
- Yabuuchi E, Kosako Y, Yano I, Hotta H, Nishiuchi Y (1995) Transfer of two Burkholderia and an Alcaligenes species to *Ralstonia* gen. nov.: proposal of *Ralstonia pickettii* (Ralston, Palleroni and Doudoroff 1973) comb. nov., *Ralstonia salanacearum* (Smith 1896) comb. nov. and *Ralstonia eutropha* (Davis 1969) comb. nov. *Microbiol Immunol* 39:897–904
- Yamada K (1977) Recent advances in industrial fermentation in Japan. *Biotech Bioeng* 19:1563–1621
- Yamamoto I, Saiki T, Liu S-M, Ljungdahl LG (1983) Purification and properties of NADP-dependent formate dehydrogenase from *Clostridium thermoaceticum*, a tungsten-selenium-iron protein. *J Biol Chem* 258:1826–1832
- Yang ST, Jin ZW, Chollar BH (1997) Production of low-cost acetate deicers from biomass and industrial wastes. *Snow Removal and Ice Control Technology*

- Transportation Research Board, National Research Council, Washington, DC, pp 60–69
- Yang ST, Huang YL, Jin Z, Huang Y, Zhu H, Qin W (1999) Calcium magnesium acetate at power-production cost: production of CMA deicer from cheese whey. US DOT Publication No. FHWA-RD-98-174
- Yasui Y (1958) Process for continuous production of vinegar. Japanese Patent 244,905 Publication No. Sho. 33–3798/1958
- Zachariou M, Scopes RK (1986) Glucose-fructose oxidoreductase, a new enzyme isolated from *Zymomonas mobilis* that is responsible for sorbitol production. *J Bacteriol* 167:863–869
- Zeikus JG (1980) Chemical and fuel production by anaerobic bacteria. *Ann Rev Microbiol* 34:423–464
- Zeikus JG, Jain MK, Elankoven P (1999) Biotechnology of succinic acid production and markets for derived industrial products. *Appl Microbiol Biotechnol* 51:545–552
- Zhang DX, Cheryan M (1994) Starch to lactic acid in a continuous membrane reactor. *Process Biochem* 29(2):145–150
- Zhang H, Obias V, Gonyer K, Dennis D (1994) Production of polyhydroxyalkanoates in sucrose-utilizing recombinant *Escherichia coli* and *Klebsiella* strains. *Appl Environ Microbiol* 60:1198–1205
- Ziffer JA, Gaffney S, Rothenberg S, Cairney TJ (1971) Aldonic acid and aldonate compositions and production thereof. British Patent 1,249,347. *Chem Abstr* 79:113

2 Organic Acid and Solvent Production: Butanol, Acetone, and Isopropanol; 1,3- and 1,2-Propanediol Production; and 2,3-Butanediol Production

Jiann-Shin Chen¹ · Mary Jo Zidwick² · Palmer Rogers*

¹Department of Biochemistry, Virginia Polytechnic Institute and State University (Virginia Tech), Blacksburg, VA, USA

²Biotechnology Development Center, Cargill, Incorporated, Minneapolis, MN, USA

<i>Butanol, Acetone, and Isopropanol</i>	78	Commercial Applications	101
Introduction	78	Commercial Production	101
Scientific Background	79	Uses	101
Physicochemical Properties	79	Areas of Research and Development	102
Solvent-Producing Bacteria	79	Microbiology of Solvent Production	102
Acetone-Producing Bacteria	80	Enzymology, Genetics, and Regulation of Solvent	
Butanol- and Acetone-Producing Bacteria	81	Production	103
Butanol- and Isopropanol-Producing Bacteria	84	Metabolic Engineering	103
Butanol-Producing Bacteria	84	Continuous Solvent Production	104
Taxonomic Studies	84	Product Recovery	105
Industrial Solvent Fermentation	85	Pilot-Plant Studies	105
Fermentable Substrates	87	Economic Evaluation	106
Bacteriophage Infections, Autolysins, and Cell		Patents and Regulatory Issues	106
Lysis	88	Prospects	107
Physiology of Solvent Production	89	<i>1,3- and 1,2-Propanediol Production</i>	107
Initiation of Solvent Production	89	Introduction	107
Relationship to Sporulation	91	Scientific Background	108
Product Pattern	92	1,3-Propanediol	108
Alcohologenic Mode of Growth	92	1,2-Propanediol	112
Strain Degeneration	92	Commercial Applications	114
Metabolic Pathways and Enzymology of Solvent		Research and Development	115
Production	93	1,3-Propanediol	115
Thiolase	94	1,2-Propanediol	117
3-Hydroxybutyryl-CoA Dehydrogenase	94	Patents and Regulatory Issues	118
Crotonase	94	Prospects for Production of 1,3-Propanediol	
Butyryl-CoA Dehydrogenase	94	and 1,2-Propanediol by a Bioprocess	118
Aldehyde Dehydrogenase	95	<i>2,3-Butanediol Production</i>	119
Alcohol Dehydrogenase	96	Introduction	119
Acetoacetate: Acetate/Butyrate CoA-transferase	96	Scientific Background	120
Acetoacetate Decarboxylase	97	Commercial Applications	122
Phosphotransbutyrylase and Butyrate Kinase	97	Research and Development	123
Phosphotransacetylase and Acetate Kinase	98	Patents and Regulatory Issues	125
Genes and Operons for Solvent Production and the		Prospects	125
Genome of Solvent-Producing Bacteria	98		
Tools for the Genetic Manipulation of Solvent-			
Producing Clostridia	100		

*Deceased

Abstract

The versatility of bacteria in the production of commercially useful chemicals is well represented by the fermentations that produce butanol, acetone, isopropanol, 1,3- and 1,2-propanediol, and 2,3-butanediol. Most of these chemicals can be synthesized from petroleum-derived feedstock chemicals. The merit of industrial applications of these fermentations ultimately depends on the economics of the bioprocesses or the need for a chiral product, which is more easily achieved through a bioprocess. Butanol, acetone, and isopropanol were traditionally used as solvents, and the industrial fermentation producing these chemicals was thus known as the solvent fermentation. Solvent fermentation is performed by several species of Clostridia, and it was the first industrial fermentation utilizing pure cultures and aseptic techniques. Its large scale was also unprecedented. Butanol has desirable properties as an automobile fuel, and this potential use has received much attention. Current efforts in improving butanol fermentation for industrial uses focus on the development of less expensive raw materials, a higher final product concentration, and bacterial strains that are more amenable to genetic manipulations. Whereas 1,2-propanediol is produced in large quantities by a chemical process, 1,3-propanediol has been more difficult to produce via chemical synthesis. Because of the usefulness of 1,3-propanediol as a monomer for the production of polyester for fiber applications, industrial interest in bioproduction of this monomer remains high. 2,3-Butanediol is produced by a number of bacteria, and it is a commercial chemical intermediate. Perhaps the greatest potential for 2,3-butanediol lies in high-value, special-product uses, which may make a fermentation route competitive.

Butanol, Acetone, and Isopropanol

Introduction

Butanol (also known as *n*-butanol or 1-butanol), acetone, and isopropanol (2-propanol) are major fermentation products of several species of clostridia. As microbial products, butanol, acetone, and isopropanol are usually studied together because their production involves shared metabolic pathways. These three compounds are important industrial chemicals with a broad range of uses. They also have potential uses as additives in automobile fuels because of their oxygen content, octane rating, heating value, and capacity to increase water tolerance of ethanol-gasoline blends. At present, butanol and isopropanol are commercially produced by synthesis using petroleum-derived propylene as the starting material. Acetone is coproduced during the synthesis of phenol, and this route satisfies the bulk of the market need for acetone. Therefore, isopropanol is a useful by-product from a biomass-based process for the production of butanol, whereas acetone is not as desirable unless the manufacturing method for phenol or the relative market need for acetone and phenol changes.

Because acetone and butanol were traditionally used as solvents, the industrial fermentation for the production of

acetone, butanol, and isopropanol is known as the “solvent fermentation.” Industrial solvent fermentation is unique: It was the first industrial fermentation utilizing pure cultures and aseptic techniques, its large scale was unprecedented, and it was the first method for the production of butanol as a commodity chemical. In addition, modern industrial microbiology is based on the serendipitous history behind the development of this industrial fermentation (Kelly 1936), the pivotal role played by the scientist-turned-statesman Chaim Weizmann in this endeavor (Rose 1986), and the intricate relationship between enterprising scientists and businessmen who turned this fermentation into a successful industry (Rose 1986). With its preeminent past and the continued improvements through research, solvent fermentation may serve to demonstrate the practicality of changing a petroleum-based economy back to a biomass-based (or bio-based) economy, which will utilize biomass-derived feedstocks to produce liquid fuels, organic chemicals, and materials. For the United States, a bio-based economy has been advocated as the primary route toward a sustainable and secure future (Thayer 2000).

Butanol-acetone fermentation was first developed to produce butanol for use in the manufacture of synthetic rubber. However, it was the need for acetone as a solvent during World War I that provided the impetus for developing this fermentation into a successful industrial process. After World War I, the established fermentation process was used commercially to produce butanol needed to make butyl acetate (a solvent for the rapidly growing lacquer industry; Gabriel 1928). The industrial process went through significant changes in the ensuing 15 years as both the organisms and the raw materials for the fermentation were changed as a result of continued efforts to improve this fermentation (Beesch 1952, 1953).

Although most known solvent-producing clostridia produce both acetone and butanol, the discovery of these chemicals as products of microbial fermentation was reported half a century apart and with different organisms. Pasteur in 1861–1862 (McCoy et al. 1926; Dürre and Bahl 1996) reported the production of butanol by butyric acid-producing microorganisms, whereas Schardinger in 1905 (Prescott and Dunn 1959b) reported the production of acetone by *Bacillus macerans*, which is not a butanol or butyric acid-producing organism. It was Fernbach who observed the production of both acetone and butanol by a bacillus he isolated for the production of butanol, which was used in the production of butadiene for the manufacture of synthetic rubber (Fernbach and Strange 1911). Industrial solvent fermentation began in 1913 as a process for producing butanol from potatoes (Gabriel 1928).

The outbreak of World War I in 1914 changed the course of industrial solvent fermentation. To make large amounts of acetone needed in Britain as a solvent for the production of the smokeless explosive cordite, the Fernbach and Strange process was used at first (Gabriel 1928). However, when the Weizmann bacterium or BY (which was later named “*Clostridium acetobutylicum*”) was found to produce from corn more acetone and butanol than the Fernbach bacillus produced,

it replaced the Fernbach bacillus for the production of acetone, first in Britain and then in North America, during World War I (Gabriel 1928). After the armistice in 1919, acetone was no longer in demand and the government-operated fermentation system was terminated. However, butanol was soon found to be extremely valuable for the manufacture of the fast-drying lacquer used by the automobile industry. Thus, beginning in 1920, solvent fermentation (used to produce butanol and acetone or isopropanol and other products) was a major commercial operation for four decades. For about a decade, the industry used the patented Weizmann process exclusively, with strains of *C. acetobutylicum* developed against phage infections and with corn as the raw material. But by 1933, the raw material was switched to molasses, and *C. acetobutylicum* (which is not productive in a molasses-based medium) was replaced by an organism known as “No. 8” (Kelly 1936). This switch in raw materials and organisms occurred before the expiration of the Weizmann patent in 1936.

When the raw material was switched from corn to molasses, many new patents were issued for the molasses-based fermentation processes, and many newly isolated bacteria for these processes were named in the patents (Beesch 1952). Public culture collections have maintained some of these molasses-fermenting solvent-producing clostridia, most of which were referred to as strains of *C. acetobutylicum* either by the culture collections or by the investigators. When research on solvent fermentation became active again in the late 1970s, several strains of “*C. acetobutylicum*” from public and private culture collections were extensively studied, and these “*C. acetobutylicum*” strains displayed surprisingly different properties (Johnson and Chen 1995; Keis et al. 1995).

A systematic study of these cultures revealed nine groups (Keis et al. 1995), whereas analysis of DNA-DNA reassociation identified these cultures as strains of four species (Johnson and Chen 1995; Johnson et al. 1997). These four *Clostridium* species, *C. acetobutylicum*, *C. beijerinckii*, *C. saccharobutylicum*, and *C. saccharoperbutylacetonicum*, can now be differentiated by their genetic and phenotypic traits (Johnson et al. 1997; Keis et al. 2001a). Several other characterized species of *Clostridium* produce butanol but in lower concentrations than that produced by these four *Clostridium* species (see the section [▶ “Solvent-Producing Bacteria”](#) in this chapter).

In addition to the correct identification of the solvent-producing organisms, much progress has been made since the early 1980s in determining the properties of the solvent-producing enzymes (see the section [▶ “Metabolic Pathways and Enzymology of Solvent Production”](#) in this chapter) and their structural genes (see the section [▶ “Genes and Operons for Solvent Production and the Genome of Solvent-Producing Bacteria”](#) in this chapter). Manipulation of the genes encoding the acid- and solvent-producing enzymes in *C. acetobutylicum* has demonstrated the feasibility of reaching a butanol concentration higher than any previously reported values (see the section [▶ “Metabolic Engineering”](#) in this chapter). The genome of *C. acetobutylicum* ATCC 824 has now been

sequenced (Nölling et al. 2001), which should facilitate the characterization of the regulatory mechanisms for solvent production.

Since the mid-1980s, a number of reviews have been written on microbial production of butanol, acetone, and isopropanol (Jones and Woods 1986; McNeil and Kristiansen 1986; Dürre and Bahl 1996; Dürre 1998; Rogers 1999). There are also reviews that cover all aspects of industrial solvent fermentation (Gabriel 1928; McCutchan and Hickey 1954; Ryden 1958; Prescott and Dunn 1959c; Ross 1961; Hastings 1978). The following reviews address in detail specific aspects of solvent fermentation or the solvent-producing clostridia: microbiology (Beesch 1952; 1953; Prescott and Dunn 1959c; Johnson and Chen 1995; Jones and Keis 1995), biochemistry and physiology (Rogers 1986; Chen 1993, 1995; Bennett and Rudolph 1995; Dürre et al. 1995; Girbal and Soucaille 1998; Mitchell 1998), genetics (Rogers 1986; Minton and Oultram 1988; Young et al. 1989; Woods 1995; Dürre 1998), industrial processes (Killeffer 1927; Gabriel 1928; Beesch 1952; 1953; McCutchan and Hickey 1954; Ryden 1958; Spivey 1978; Walton and Martin 1979), and history (Gabriel 1928; Gabriel and Crawford 1930; Kelly 1936; McCutchan and Hickey 1954; Jones and Woods 1986).

Scientific Background

Physicochemical Properties

The physicochemical properties of acetone, butanol, and isopropanol are listed in [▶ Table 2.1](#). Ethanol is included in the table because it is a product of all known solvent-producing bacteria and because these four compounds share properties which make them useful as oxygenates and as octane-rating enhancers in gasoline (see “Ethanol” in Chapter 3 of this volume). These compounds, because of their similar fuel properties, can be used as a mixture in gasoline or diesel. Besides increasing the oxygen content and the octane rating, acetone and isopropanol can increase the water tolerance of the ethanol-gasoline mixture (see the section [▶ “Uses”](#) in this chapter).

Solvent-Producing Bacteria

The early history (1861–1909) of the discovery of the butanol-, acetone-, and isopropanol-producing bacteria has been reviewed by Dürre and Bahl (1996), who listed 22 references (all in either German or French) documenting the contribution of Pasteur, Fitz, Beijerinck, Schardinger, and Pringsheim to the field. Pasteur, Schardinger, and Pringsheim, respectively, were the first to observe or report the production of, respectively, butanol, acetone, and isopropanol by anaerobic bacteria. Pasteur coined the term “anaerobic” to describe butyric acid- and butanol-producing bacteria that were killed in air.

Table 2.1
Physical properties of the neutral products of the solvent-producing bacteria

	Acetone	<i>n</i> -Butanol	Isopropanol	Ethanol
Formula	(CH ₃) ₂ CO	CH ₃ (CH ₂) ₃ OH	(CH ₃) ₂ CHOH	C ₂ H ₅ OH
Mol. wt.	58.08	74.12	60.09	46.07
Boiling point (°C)	56.5	117.7	82.5	78.5
Specific gravity	0.791 (20°/20°)	0.811 (20°/4°)	0.785 (20°/4°)	0.789 (20°/4°)
Pounds/gal	6.58	6.75	6.55	6.578
Heating value				
Btu/gal	93,028	103,849	87,400	76,000
MJ/l	26	29	24	21
Oxygen content	27.6	21.6	26.6	34.7
RON ^a		113	121 ^b	106, 130 ^b
MON ^a	93	94	96 ^b	92, 96 ^b

Abbreviations: *Btu* British thermal units; *MJ* megajoules; *RON* research octane number, the number used in predicting antiknock performance during low-speed acceleration; and *MON* motor octane number, the number used in predicting antiknock performance at high constant speed

^aIn gasoline blends, these and other measurements of octane numbers are influenced by the composition of the base fuel and other factors, which makes it difficult to give absolute values for the octane quality of the various alcohols and oxygenates (Owen and Coley 1990; Houben 1995)

^bBlending octane numbers (Houben 1995)

All known butanol-producing and most acetone-producing organisms are gram-positive, spore-forming bacteria, and all produce ethanol in addition to butanol and acetone or isopropanol. Processes using butanol-producing bacteria yield less ethanol than other neutral products, whereas processes using bacteria that do not produce butanol yield more ethanol than acetone, which can be explained by the fact that the latter organisms (such as *B. macerans*) dispose of excess reducing power mainly through ethanol production.

The correct identification of the butanol- and acetone-producing clostridia is difficult because they are phenotypically similar. In addition, some useful criteria for bacterial identification are not reliable when applied to this group of organisms. The fatty acid composition of the membrane lipids (Lepage et al. 1987) and the pattern of fermentation products change when cells switch from the acid-producing stage to the solvent-producing stage of growth or when solventogenesis occurs under slightly different conditions. Although the phylogeny of the genus *Clostridium* can be deduced from a comparison of 16S rRNA sequences (Collins et al. 1994), data of chromosomal DNA-DNA hybridization are necessary to establish the species status (Stackebrandt and Goebel 1994). Most of the recognized species of solvent-producing clostridia have been examined by the DNA-DNA hybridization technique (Cummins and Johnson 1971; George et al. 1983; Johnson et al. 1997).

The solvent-producing bacteria may be divided into four groups (☛ Table 2.2) according to their major end products: (1) those producing acetone but not butanol or isopropanol, (2) those producing butanol and acetone, (3) those producing isopropanol in addition to acetone and butanol, and (4) those producing butanol but not acetone. The salient properties of species within each group are described below.

Acetone-Producing Bacteria

Acetone as a product of bacterial fermentation was first reported by Scharlinger in 1905 (Prescott and Dunn 1959b) when the species *Bacillus macerans* was named. Ethanol, acetone, and acetic and formic acids are the major end products from the fermentation of potatoes or potato starch in media also containing peptone and calcium carbonate. Subsequently, an organism named “*Bacillus acetoethylicum*” (later changed to “*Bacillus acetoethylicus*” and is now considered synonymous to *B. macerans*) was isolated (Northrop et al. 1919) and used in the study of factors influencing acetone formation (Arzberger et al. 1920). “*Bacillus acetoethylicum*” produced ethanol (12–26 % of the weight of the carbon substrate) and acetone (4–10 % of the weight of the carbon substrate) from mono-, di-, and polysaccharides; however, it produced ethanol (40–43 % of the weight of the carbon substrate) but no acetone when glycerol was the fermentation substrate (Northrop et al. 1919). The lack of acetone production has also been observed with *Clostridium acetobutylicum* when it is grown under the alcoholic conditions (see the section ☛ “Physiology of Solvent Production” in this chapter), which include the use of a mixture of glucose and glycerol in the growth medium (Girbal and Soucaille 1994; Vasconcelos et al. 1994).

Acetone production by *B. macerans* occurs late in the fermentation and is enhanced by a low culture pH (Prescott and Dunn 1959b). A significant increase in acetone (from 12 to 40 mM) and ethanol (from 44 to 154 mM) production by *B. macerans* ATCC 7068 was observed when CaCO₃ (100 mM) and sodium acetate (24 mM) were added to the CM5 medium containing 2 % glucose and 0.2 % yeast extract (Weimer 1984a).

■ Table 2.2

Four groups of solvent-producing bacteria^a on the basis of their neutral end products

Neutral end products			
Acetone	Butanol and acetone	Butanol, isopropanol, and acetone	Butanol
<i>Bacillus macerans</i>	<i>Clostridium acetobutylicum</i>	<i>Clostridium aurantibutyricum</i>	<i>Clostridium tetanomorphum</i>
<i>Methylosinus trichosporium</i>	<i>Clostridium beijerinckii</i> (some strains)	<i>Clostridium beijerinckii</i> (some strains)	<i>Clostridium thermosaccharolyticum</i>
	<i>Clostridium saccharoperbutylacetonicum</i>	" <i>Clostridium toanum</i> "	
	<i>Clostridium saccharobutylicum</i>		
	<i>Clostridium puniceum</i>		
	<i>Clostridium pasteurianum</i>		

^aAll produce ethanol

In addition to strains maintained at national culture collections, the culture collection of the United States Department of Agriculture (USDA) at the Midwest Area National Center for Agricultural Utilization Research in Peoria, Illinois, maintains many strains of *B. macerans*, which carry the designation "NRRL." These NRRL strains of *B. macerans* include the NRS strains originally maintained by N. R. Smith. The following NRRL strains of *B. macerans* produced 20–40-mM acetone and >150-mM ethanol at 35 °C in the CM5 medium (see above) containing 2 % glucose and 0.2 % yeast extract without the addition of CaCO₃ or sodium acetate: B-392 (NRS-646), B-433 (NRS-1098), B-434 (NRS-1099), and B-3185 (NRS-649; P. Moldenhawer and J.-S. Chen, unpublished result).

Acetone is also produced from poly-3-hydroxybutyrate by the methylobacterium *Methylosinus trichosporium* OB3B (Thomson et al. 1976). It was proposed that poly-3-hydroxybutyrate is metabolized to 3-hydroxybutyrate and acetoacetate, whereas acetone is produced from acetoacetate via acetoacetate decarboxylase (reaction 17 in ► Fig. 2.1).

Butanol- and Acetone-Producing Bacteria

Clostridium acetobutylicum is the best known butanol- and acetone-producing organism, and some misconception about this species persists in the literature. Elizabeth McCoy and coworkers at the University of Wisconsin proposed the name "*Clostridium acetobutylicum*" in 1926 for "the acetone butyl alcohol organism" represented by the 11 strains they used in a cultural study (McCoy et al. 1926). Seven of the eleven strains were received from the Commercial Solvents Corporation of Terre Haute (Indiana, United States), and the other four (strains 6, 8, 10, and 11) were from the Department of Agricultural Bacteriology at the University of Wisconsin (McCoy et al. 1926; McCoy and McClung 1935). Strain 1 of this study was believed to be a Weizmann culture although its history was

not fully known (McCoy and McClung 1935). In 1927, Weyer and Rettger (1927) reported the result of a comparative study of six cultures of the acetone butyl alcohol organism, one of which was isolated from Connecticut (United States) garden soil in October 1924 and was designated "strain So," which eventually became ATCC 824, the type strain for the species *C. acetobutylicum* (McCoy and McClung 1935). Weyer and Rettger (1927) supported the use of the name *Clostridium acetobutylicum* for this group of organisms. In a study on "the serological agglutination of *Clostridium acetobutylicum* and related species" (McCoy and McClung 1935), 22 cultures were used and they included "strain W₁₇" as well as "strain 1" (believed to be a Weizmann culture) and "strain W" (the Weyer and Rettger strain So; now ATCC 824). Strain W₁₇ was an original Weizmann culture, which was "preserved in a sealed spore stock for 17 years by Weizmann, and received by us through one intermediate, the late Sir Frederick Andrews of London" (McCoy and McClung 1935). Results of these cultural and serological studies support the conclusion that these strains are sufficiently similar among themselves and different from other known species to be considered *C. acetobutylicum*.

Some publications incorrectly credited Chaim Weizmann for proposing the name *Clostridium acetobutylicum*. McCoy and McClung (1935) clearly stated "discovery of the organism and certainly discovery of its usefulness in industrial fermentation is attributed to Weizmann, who, though he never fully described or named his organism, succeeded in differentiating it from formerly known butyl-alcohol-producing anaerobes." For several reasons, some investigators thought that Weizmann named the species *C. acetobutylicum*. McCoy and coworkers (McCoy et al. 1926) proposed the name "*Clostridium acetobutylicum* (Weizmann)" [sic] for the species, whereas Weyer and Rettger (1927) gave the name "*Clostridium acetobutylicum*, Weizmann" [sic] in the description chart for their strain So (now ATCC 824). Statements such as "the butyl alcohol organism of Weizmann, *Clostridium acetobutylicum*" (McCoy and McClung 1935) and "*Clostridium acetobutylicum*

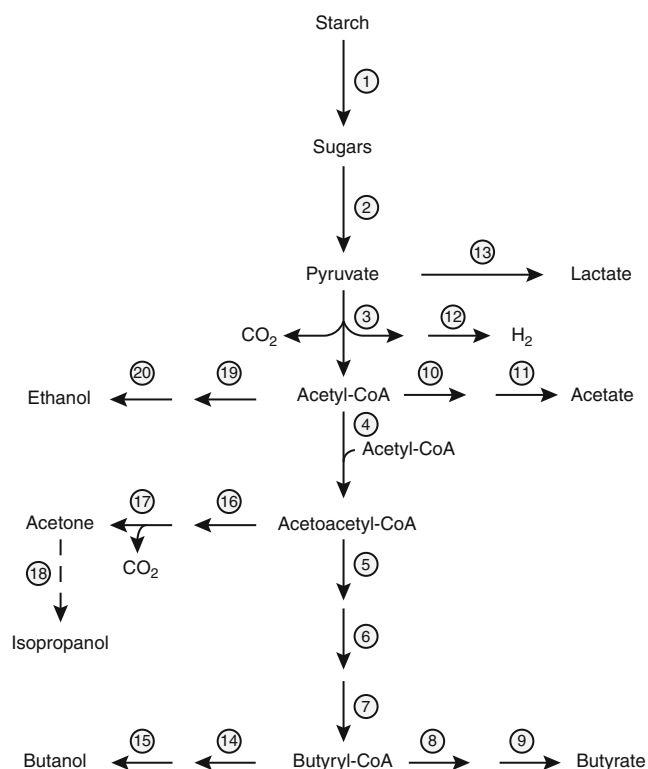

Fig. 2.1

Metabolic pathways for the fermentation of starch and sugars to acids, solvents, hydrogen, and carbon dioxide in the clostridia. Arrows indicate the direction of carbon or electron flow as well as the major steps of the pathways. The enzyme(s) catalyzing the reaction(s) represented by an arrow is numbered: 1 amylase, 2 phosphoenolpyruvate-phosphotransferase systems and glycolytic enzymes of the Embden-Meyerhof-Parnas pathway, 3 pyruvate:ferredoxin oxidoreductase, 4 thiolase, 5 3-hydroxybutyryl-CoA dehydrogenase, 6 crotonase, 7 butyryl-CoA dehydrogenase, 8 phosphotransbutyrylase, 9 butyrate kinase, 10 phosphotransacetylase, 11 acetate kinase, 12 hydrogenase, 13 lactate dehydrogenase, 14 aldehyde (butyraldehyde) dehydrogenase and aldehyde/alcohol dehydrogenase, 15 alcohol (butanol) dehydrogenase and aldehyde/alcohol dehydrogenase, 16 acetoacetate: acetate/butyrate CoA-transferase, 17 acetoacetate decarboxylase, 18 primary/secondary alcohol dehydrogenase, 19 aldehyde (acetaldehyde) dehydrogenase, and 20 alcohol (ethanol) dehydrogenase. The dashed line to isopropanol indicates that only some strains of a species are able to perform this reaction (From Dürre 1998)

Weizmann [sic]” in the biography for Weizmann (Rose 1986) probably also contributed to the misconception. That the strain *So* (now ATCC 824), which was isolated by Weyer and Rettger, was designated “strain W” by McCoy and McClung (1935) may also have misled some investigators to think that strain ATCC 824 was the Weizmann strain.

Weizmann did not fully describe the isolation of the organism that was successfully used in industrial production of

acetone and butanol from corn, which may have prompted John J. H. Hastings to suggest “Weizmann obtained such an organism, though it is possible that he did not isolate it himself” (Hastings 1971) and “there is some doubt whether he in fact isolated his own culture or obtained it from an existing source” (Hastings 1978). However, in the Weizmann biography (p. 120; Rose 1986), it is stated that “. . . Weizmann turned to a relatively new field: microbiology. From the spring of 1909 he began to spend his vacations at the Pasteur Institute in Paris.” Weizmann studied microbiology under Professor Auguste Fernbach, the director of the Fermentation Laboratories of the Pasteur Institute, and was considered by contemporary microbiologists as “a student of Fernbach’s” (Arzberger et al. 1920). It is thus conceivable that Weizmann was proficient in anaerobic bacteriological techniques and capable of isolating from corn the strain used in his industrial process awarded the 1915 British Letters patent no. 4845 (Weizmann 1915). Fernbach isolated an organism (bacillus of the type of Fitz or BF) that produced acetone and butanol from potatoes but not corn, and the industrial performance of the Fernbach’s patented process (Fernbach and Strange 1911) was inferior to the Weizmann process using *C. acetobutylicum* and corn mash (see the section “Industrial Solvent Fermentation” in this chapter). After the outbreak of World War I, the Fernbach process was replaced by the Weizmann process for better acetone production (Gabriel 1928; Gabriel and Crawford 1930).

As an obligate anaerobe, *C. acetobutylicum* is relatively insensitive to O_2 , which was considered somewhat paradoxical because

- ▶ . . . it can be cultured in open tubes of fresh carbohydrate media... Germination of spores in air is not possible as in the case of ordinary facultative organisms. And yet after a culture is well started in corn mash, oxygen may be bubbled through it intermittently without seriously disturbing its fermentation. Likewise, colonies developed in an anaerobic jar may on removal to air continue to grow by piling up of the bottom layers of growth (McCoy et al. 1926).

The oxygen tolerance of *C. acetobutylicum* may have contributed to its commercial success and is a useful property.

In 1926, the name “*Clostridium acetonigenum*” was proposed by H. J. L. Donker, a Dutch microbiologist at Delft, for the species now known as “*C. acetobutylicum*.” To circumvent the need to determine the priority of the names and to avoid confusion, the Dutch scientist later withdrew the name “*Clostridium acetonigenum*” (McCoy and McClung 1935).

Clostridium acetobutylicum can use a wide range of carbohydrates ranging from pentoses to starch for growth and is strongly proteolytic. Production of acetone and butanol from sugars by *C. acetobutylicum*, however, requires close control of the pH of the medium. Corn mash, on the other hand, has the right buffering capacity so that this species can without pH control produce acetone and butanol in corn mash. An inability to produce high levels of solvents from molasses distinguishes *C. acetobutylicum* from the other solvent-producing clostridia. *Clostridium acetobutylicum* can now be clearly differentiated from the other solvent-producing species by measuring

DNA-DNA reassociation (Johnson et al. 1997) or by comparing several genetic and phenotypic traits (Keis et al. 2001a).

Although acetone, butanol, and ethanol are the characteristic end products of *C. acetobutylicum* during the well-known solventogenic mode of growth, there is another solventogenic mode of growth, dubbed alcohologenesis, during which *C. acetobutylicum* produces butanol and ethanol but little or no acetone. See the section [“Physiology of Solvent Production”](#) in this chapter for growth conditions leading to alcohologenesis.

Clostridium beijerinckii (one of the molasses-fermenting butanol-producing clostridia) is less well known than *C. acetobutylicum* because many strains of this species were previously given different species names. *Clostridium beijerinckii* replaced *C. acetobutylicum* for commercial solvent production after the corn-based Weizmann process was phased out in the late 1930s (Johnson and Chen 1995; Jones et al. 2000). Many extant strains of *C. beijerinckii* have been definitively identified by DNA-DNA reassociation or a combination of traits and are available from culture collections (Cummins and Johnson 1971; Johnson et al. 1997; Keis et al. 2001a).

Clostridium acetobutylicum and *C. beijerinckii* are among the many species of butyric acid-producing clostridia that are difficult to differentiate on the basis of morphological and growth characteristics alone. The seventh edition of *Bergey's Manual of Determinative Bacteriology* listed 19 species of nonpathogenic, butyric acid-producing clostridia (Cummins and Johnson 1971). Measurements of DNA-DNA reassociation and cell wall composition allowed the identification of a species (homology group II) of butyric acid-producing clostridia (e.g., *C. beijerinckii*; Cummins and Johnson 1971). This group initially consisted of 20 cultures previously designated as “*C. butyricum*,” “*C. multifermentans*,” “*C. amylolyticum*,” “*C. rubrum*,” “*C. lacto-acetophilum*,” and “*C. aurantibutyricum*” (Cummins and Johnson 1971). Notably, only some of the strains previously labeled as members of these species as well as “*Clostridium butylicum*” (George et al. 1983), “*C. madisonii*” (Keis et al. 2001a), several strains of *C. acetobutylicum*, and others (Johnson et al. 1997) were found to belong to *C. beijerinckii*.

The species *C. beijerinckii* was named after the Dutch bacteriologist M. W. Beijerinck by Donker in his 1926 thesis (George et al. 1983). At that time, *C. beijerinckii* was thought to be unable to ferment starch and hence differed from “*Clostridium butylicum*” (originally “*Granulobacter butylicum* Beijerinck 1893”). However, many strains of *C. beijerinckii* have since been found to ferment starch (George et al. 1983; Nimcevic et al. 1998), and *C. beijerinckii* NRRL B592 has been used in pilot-plant studies to produce solvents from potatoes (Nimcevic and Gapes 2000). Although the name “*C. butylicum*” would have priority over *C. beijerinckii*, an apparent oversight during the preparation of the 1980 *Approved Lists of Bacterial Names* resulted in the use of *C. beijerinckii* as the name for this solvent-producing species (George et al. 1983). *Clostridium beijerinckii* also contains strains that produce isopropanol, instead of acetone, as a major end product. When methyl

viologen is added to the medium, *C. beijerinckii* NRRL B591 (formerly labeled as “*C. acetobutylicum*”) produces either ethanol (pH 6.8) or butanol and ethanol (pH 5) but with little or no acetone (Rao and Mutharasan 1986).

Clostridium aurantibutyricum is a species distinguishable from *C. beijerinckii* and *C. butyricum* on the basis of DNA-DNA reassociation (Cummins and Johnson 1971). Two strains (including the type strain) of *C. aurantibutyricum* have been examined for solvent production, and both produce butanol, acetone, and isopropanol from glucose (George et al. 1983). It is not known whether isopropanol production is a general property of this species; however, many strains of *C. beijerinckii* produce acetone but not isopropanol, and some do not produce solvents under conditions that are solventogenic for the producing strains (Chen and Hiu 1986).

Clostridium saccharoperbutylacetonicum was isolated from Japanese soil by Hongo and Nagata in 1959 (Hongo and Murata 1965a). Derivatives of *C. saccharoperbutylacetonicum* strain N1 were used in industrial production of acetone and butanol from molasses in Japan between 1959 and 1960 (Ogata and Hongo 1979). This species was chosen for industrial application because it produced a high proportion of butanol (Hongo and Murata 1965a). During the period that *C. saccharoperbutylacetonicum* was used in industrial butanol production, a series of phage-resistant strains (such as *C. saccharoperbutylacetonicum* strains N1-120, N1-508, and N1-621) were selected to counter the frequent occurrence (12 times in a year) of phage contamination of the fermentation (Hongo and Murata 1965a; Ogata and Hongo 1979), and a record of their development is available.

“*Clostridium saccharobutylicum*” is the name proposed (Keis et al. 2001a) for the species represented by strains NCP 262 (also known as P262 or NCP P262) and NRRL B-643 (Johnson and Chen 1995; Johnson et al. 1997). Strain NCP 262 was one of the production strains used at the National Chemical Products (NCP) plant in Germiston, South Africa (Keis et al. 1995), whereas strain NRRL B-643 was provided by Commercial Solvents Co. to Northern Regional Research Laboratory (now Midwest Area National Center for Agricultural Utilization Research) of the USDA (L. K. Nakamura, personal communication). The Commercial Solvents Co. utilized a number of molasses-fermenting clostridia for solvent production after the expiration of the Weizmann patent (see the section [“Industrial Solvent Fermentation”](#) in this chapter).

Clostridium puniceum produces butanol and acetone from glucose or starch, and a molar ratio of butanol (179 mM) to acetone (16.8 mM) reached above 10 in a fed-batch fermentation with a total of 7.2 % (w/v) of glucose (Holt et al. 1988). *Clostridium puniceum* is a pink-pigmented, pectinolytic bacterium (Lund et al. 1981), while *C. beijerinckii* NRRL B592 produces a pink-lavender pigment (J.-S. Chen, unpublished observation). On the basis of 16S rRNA sequences, *C. puniceum* is phylogenetically close to *C. beijerinckii* and three not validly published clostridial species “*C. corinoforum*,” “*C. favososporum*,” and “*C. caliptrosporum*” (Collins et al. 1994). *Clostridium puniceum* has not been examined by the DNA-DNA reassociation technique.

Clostridium pasteurianum ATCC 6013 produces acetone (90 mM), butanol (135 mM), and a low level of ethanol in a mineral salts medium with 12.5 % (w/v) of glucose (Harris et al. 1986). In media containing 3.5 % (w/v) or less of glucose, *C. pasteurianum* produced only low levels of butanol and little or no acetone (George et al. 1983; Harris et al. 1986; Dabrock et al. 1992). A newly isolated strain of *C. pasteurianum* produced acetone and butanol from 3 % dahlia inulin (Oiwa et al. 1987). *Clostridium pasteurianum* produces butanol, 1,3-propanediol, and ethanol from glycerol (Nakas et al. 1983; Heyndrickx et al. 1991; Dabrock et al. 1992).

Butanol- and Isopropanol-Producing Bacteria

Some strains of *Clostridium aurantibutyricum* and *C. beijerinckii* have the capacity to reduce acetone to isopropanol, and in these organisms, isopropanol may supercede acetone as the second most abundant neutral end product after butanol (George et al. 1983). The butanol- and isopropanol-producing organism “*Clostridium toanum* Baba” (Prescott and Dunn 1959c) was used in large-scale production of butanol and isopropanol in Taiwan between 1942 and 1958 (see the section “Industrial Solvent Fermentation” in this chapter), but this organism is not available from any major culture collection.

Butanol-Producing Bacteria

When a viologen dye or one of the other additives is present in the growth medium and the pH is maintained above a certain value, *C. acetobutylicum* and *C. beijerinckii* produce butanol and ethanol but not acetone (see the section “Physiology of Solvent Production” in this chapter). There are other species of clostridia that produce butanol but not acetone or isopropanol in growth media without these additives. They include *Clostridium tetanomorphum* (Gottwald et al. 1984) and *Clostridium thermosaccharolyticum* (Freier-Schroeder et al. 1989). The amount of butanol produced by these species is much less than that produced by the acetone- and butanol-producing species.

Taxonomic Studies

For over 60 years, many strains of solvent-producing clostridia were used in large-scale commercial production. Other strains that were developed for patented processes and documented in the literature were not actually used in commercial production. Some of these strains are still available from culture collections, but many of them have been assigned incorrect species names. Historically, strains that are similar enough to qualify as members of the same species were often given different species or genus names when they were part of patented processes (Beesch 1952). After the expiration of the patents, culture collections and individual laboratories may do the reverse, i.e., lump genuinely different organisms into a single species. The latter practice is especially problematic because seemingly contradictory

properties would be reported for cultures labeled with the same name but actually belonging to different species (Johnson and Chen 1995).

When the species *C. acetobutylicum* was proposed by McCoy and coworkers (McCoy et al. 1926) for the 11 strains of acetone- and butanol-producing clostridia that include a strain believed to have come from Weizmann (McCoy and McClung 1935), the comprehensive cultural study provided a detailed description of the organism’s growth characteristics. For many of the solvent-producing clostridia that were isolated later for the molasses (sucrose)-based fermentation, there are no published records of comparably comprehensive cultural studies, but some of these cultures were labeled as *C. acetobutylicum* after they were maintained in the culture collections (Johnson and Chen 1995; Keis et al. 1995; 2001a; Johnson et al. 1997). The loose use of species names plagued the early investigators (McCoy and McClung 1935), and it remains a problem now. Attention to the current definition for a bacterial species (Johnson 1984) and the proper procedure for differentiating species (Stackebrandt and Goebel 1994) should be helpful.

For phenotypically similar bacteria, provided they share a similar DNA base composition (mol% G + C), which is a characteristic of most solvent-producing clostridia, the DNA-DNA reassociation technique is required to separate them to the species level (Stackebrandt and Goebel 1994). On the basis of percent DNA relatedness as measured by DNA-DNA reassociation, cultures of “*C. acetobutylicum*” from various collections can be clearly separated into four species (Johnson and Chen 1995; Johnson et al. 1997): *C. acetobutylicum*, *C. beijerinckii*, *C. saccharoperbutylacetonicum*, and *C. saccharobutylicum* (Keis et al. 2001a). On average, *C. acetobutylicum* strains have a 10 % DNA sequence similarity with the other three species, whereas the other three species share a 20 % sequence similarity. Within each species, the level of DNA sequence similarity among strains is between 70 % and 100 %, except for strain NCIMB 6444, which has a similarity level between 54 % and 80 % (average 69.6 %) with 16 strains of *C. beijerinckii*. The cutoff value for strains to be considered as belonging to the same species is 70 % (Johnson 1984).

Using DNA fingerprinting and biotyping (susceptibility to rifampin, inhibition by bacteriocins, and cell lysis by bacteriophages), 55 cultures of solvent-producing clostridia (most of them having been labeled as “*C. acetobutylicum*”) were separated into nine groups (Keis et al. 1995). Sequence analyses of the partial and almost complete 16S rRNA genes of strains representing the nine groups clearly separated *C. acetobutylicum* strain ATCC 824 from the others; however, these other strains of solvent-producing clostridia shared a 16S rRNA sequence similarity above 98 % and could not be further divided into groups. In fact, some of these strains are more similar to each other (such as *C. saccharobutylicum* strain NCP 262 and *C. saccharoperbutylacetonicum*) than to *Clostridium puniceum* on the basis of 16S rRNA sequence (Keis et al. 1995). That bacterial species within a genus cannot generally be differentiated on the basis of the 16S rRNA sequence has been emphatically pointed out (Stackebrandt and Goebel 1994).

Industrial Solvent Fermentation

Solvent fermentation was a significant industrial process between the late 1910s and early 1960s, and it was used for commercial purposes for most of this period. After the early 1960s, use of this biomass-based fermentation process remained practical at only a few places. The continued operation of this fermentation in those localities as well as the operation before the fermentation was commercialized shows that the usefulness of solvent fermentation is not solely dictated by commercial or economic factors; the bacterial process enables a nation to use locally generated biomass, instead of imported or strategically more important raw materials, to produce needed chemicals. Examples of such strategic operations are the production of acetone for the British navy during World War I (Jones and Woods 1986), the production of butanol for Japanese armed forces during World War II (Anonymous 1956), and the production of acetone and butanol in South Africa until the early 1980s (Jones and Woods 1986). The future usefulness of this fermentation will continue to be affected by national security needs.

All aspects of industrial solvent fermentation have been reviewed, both during the years of peak production (Killeffer 1927; Gabriel 1928; Gabriel and Crawford 1930; Kelly 1936; Prescott and Dunn 1949; Beesch 1952; 1953; McCutchan and Hickey 1954) and thereafter when industrial solvent fermentation was viewed from a different perspective (Ryden 1958; Ross 1961; Hastings 1971, 1978; Spivey 1978; Walton and Martin 1979; Jones and Woods 1986; McNeil and Kristiansen 1986). Therefore, only a brief history of industrial solvent fermentation is given here.

Industrial interests in butanol fermentation began during the first decade of the twentieth century because of a drive to make synthetic rubber. Butadiene, a leading monomer being considered for polymerization into synthetic rubber, can be manufactured from butanol, but at that time, butanol had not been produced commercially. Auguste Fernbach, director of the Fermentation Laboratories at the Pasteur Institute (Paris), was then a principal investigator of fermentation studies, and since the spring of 1909, Chaim Weizmann began to spend his vacations with Fernbach to study fermentations (Rose 1986). In 1910, E. Halford Strange of the English firm Strange and Graham, Ltd., contracted Sir William Perkin, professor of chemistry at Manchester University (who in turn contracted his assistant Chaim Weizmann) to conduct research on synthetic rubber. From his study with Fernbach, Weizmann gained the expertise in anaerobic microbiology that he applied to his investigation in Manchester on the fermentation processes related to synthetic rubber. Through Weizmann, Fernbach was also under contract with Strange by December 1910 to work on butanol fermentation (Rose 1986).

Fernbach and Strange (1911) were issued the British patents 15,203–15,204 on “Acetone and high alcohols (amyl, butyl, or ethyl alcohols and butyric, propionic or acetic acid) from starches, sugars, and other carbohydrates.” In 1913, the first plant for the production of butanol from potatoes began in

Rainham, England, using the bacillus isolated by Fernbach (Gabriel and Crawford 1930). In the meantime, Weizmann was conducting research on butanol fermentation on his own, after he had broken his association with Perkin, Strange, and Fernbach in 1912 (Rose 1986). It was during this period that Weizmann isolated the acetone- and butanol-producing anaerobic bacterium that was later named “*Clostridium acetobutylicum*” by McCoy and coworkers (McCoy et al. 1926). *Clostridium acetobutylicum* produces useful quantities of butanol and acetone from corn, which is a property not possessed by the bacillus used in the patented process of Fernbach and Strange.

When World War I broke out in 1914, the British government recognized the usefulness of the fermentation process of Weizmann for the production of acetone, which was needed as a solvent for the production of the smokeless explosive cordite for the British navy. The process was initially used in England to produce acetone, but a shortage of corn there forced the transfer of the operation to Canada (between August 1916 and November 1918), where 3,000 t of acetone were produced for the British government. After the entry of the United States into World War I in 1917, two distilleries (the Commercial Distillery and the Majestic Distillery) in Terre Haute, Indiana, were purchased, respectively, by the British and United States governments to produce acetone, and they were in operation between May and November 1918 (Gabriel 1928). These government-operated plants were closed after armistice in November 1918. However, commercial solvent fermentation began in the United States 2 years later, and by the end of 1927, a total of 148 fermentors were in operation to produce solvents.

The commercial success of solvent fermentation was driven by the fast-growing automobile industry, which needed a fast-drying, low-viscosity paint for finishing the automobile body. Butyl acetate, which is produced from butanol, has the desired properties for the manufacturing of the fast-drying nitrocellulose lacquer. This potential use of butanol resulted in the formation of the Commercial Solvents Corporation of Maryland, which purchased from the Allied War Board the two plants at Terre Haute in 1919. Operations at the Majestic Distillery started in 1920, which is the real beginning of the commercial use of the Weizmann process and the associated organism *C. acetobutylicum* (Gabriel 1928).

The rapid growth in demand for butanol is illustrated by the rate at which the plant capacity was expanded between 1920 and 1927. The Terre Haute plant had 40 fermentors initially, and it was increased to 52 during 1923. When the plant in Peoria began operation at the end of 1923, it had 32 fermentors (50,000 gal each). A year later, the Peoria plant had 48 fermentors, and toward the end of 1927, the number increased to 96 (50,000 gal each), for a total of 148 fermentors for both plants (Gabriel 1928). By 1927, the two plants together produced more than 100 t of solvents per day (Killeffer 1927). After the expiration of the Weizmann patent in 1936, industrial solvent fermentation was practiced around the world as other companies built plants in the United States, Puerto Rico, the United Kingdom, Japan,

India, Australia, South Africa, and elsewhere (Jones and Woods 1986). Fermentors with a volume up to 15,000 barrels (472,500 gal) were used for acetone-butanol fermentation (Beesch 1953). Although molasses replaced corn as the predominant raw material in the United States, new processes utilizing starchy materials or admixtures of starchy and sugary materials were used where it is economical to do so (Beesch 1953).

The Weizmann process is based on the fermentation of corn by *C. acetobutylicum*. The kernel is ground into a coarse meal (Prescott and Dunn 1949) or a fine powder (Beesch 1953; McCutchan and Hickey 1954) and mixed with water and stillage (distillation slop), and the cooked corn mash does not require any other nutrients to be added for the fermentation. When it is economical, the germ of corn was removed for oil extraction, but the oil-cake meal may be returned to the mash to increase the feed value of the recovered solids at the end of the fermentation. Besides *C. acetobutylicum*, an unusual variant of "*Clostridium saccharo-butyl-aceticum-liquefaciens*" (known as Code C-12) was also used for the corn-based fermentation, but it required the addition of ammonia to the corn mash because of its poor proteolytic power (Walton and Martin 1979).

The concentration of corn in the mash is about 8.5 % (based on the original dried corn), and this concentration was used to ensure that the final butanol concentration in the broth (beer) did not exceed 13 g/l (1.3 % or 175 mM) and to ensure complete utilization of the starch by the end of the fermentation (Walton and Martin 1979). The normal fermentation of starches gives a final total solvent concentration of about 2.2 % (22 g/l), with an approximate 6: 3: 1 weight ratio of butanol: acetone: ethanol. This corresponds to a yield of 1 lb (0.4536 kg) of mixed solvents from 4.3 lb (1.95 kg) of corn or 2.9 lb (1.315 kg) of starch (Beesch 1953). In addition, hydrogen, carbon dioxide, and dried stillage (which contained proteins and vitamins B₂ and B₁₂ and was used in animal feeds) were recovered and sold (Walton and Martin 1979).

An interesting practice that was part of the corn- and the molasses-based fermentation is the reutilization of the distillation slop or stillage, i.e., the fermentation broth from which the solvents have been removed. This practice was known as "slopback," and the volume of the spent medium reutilized amounted to 25–50 % of the total mash (Walton and Martin 1979). The advantages of slopback include an increase in yields of solvents, a decrease in the amount of nutrients required (for the molasses-based process), and savings in heat, cooling water, and steam for the various steps. Considering the physiological effects of added acetate and butyrate on the solvent-producing bacteria (see the section ["Physiology of Solvent Production"](#) in this chapter), slopback could be an important aspect of the industrial process. A more detailed description of the industrial fermentation can be found in several reviews (Beesch 1953; Walton and Martin 1979).

Molasses was the most widely used raw material for solvent fermentation, and the use of corn or *C. acetobutylicum* was phased out by 1933 (Kelly 1936; Walton and Martin 1979). However, other starch-based processes were later developed and used for industrial production while the molasses-based

processes were in use (Beesch 1953), and some of the saccharolytic organisms are capable of fermenting starch directly under suitable conditions and producing almost full yields of solvents (Beesch 1952). Two types of molasses, the blackstrap molasses and the high-test or invert molasses, were predominantly used in industrial solvent fermentation (McCutchan and Hickey 1954; Walton and Martin 1979), although other types of molasses and sugary materials were also used (Beesch 1952).

Blackstrap molasses is the concentrated mother liquor remaining after the crystallization of sucrose from sugarcane juice and contains on average 52 % total sugars, consisting of about 30 % sucrose and 22 % invert sugar (glucose plus fructose). It contains salts that are added to aid in the recovery of crystalline sucrose. Batch-to-batch variations in the composition of blackstrap molasses caused wide variation in yields and nutrient requirements for fermentation based on this raw material (McCutchan and Hickey 1954).

High-test molasses contains about 50 % invert sugar and 25 % sucrose and is a better raw material than blackstrap molasses because it contains less nonfermentable solids, including salts, and has a more consistent composition. High-test molasses is produced from excess sugarcane. The juice is concentrated to about 70–75 % sugar in the presence of a small amount of mineral acid, which hydrolyzes (inverts) about two-thirds of the sucrose to glucose and fructose to avoid crystallization on standing (McCutchan and Hickey 1954). As in the corn fermentation, the concentration of molasses in the fermentor medium was calibrated so that it was not more than what was needed to give a final butanol concentration of 13 g/l. The sugar concentration used in the fermentor medium varied from 5.5 % to 7.5 % depending upon the solvent ratio produced by the culture selected (Walton and Martin 1979).

Although the patent literature contains the names of many organisms for the molasses-based processes (Beesch 1952), information is scarce as to the strains actually used by the industry. It is now known that the "*C. madisonii*" strain used in Puerto Rico in the 1940s (Jones et al. 2000) and the two strains (P265 and P270) used at National Chemical Products in South Africa in the late 1970s (Spivey 1978) are *C. beijerinckii* (Keis et al. 2001a). Before solvent fermentation was terminated in Japan in the early 1960s, the organisms used were strains of *C. saccharoperbutylacetonicum* (Hongo and Murata 1965a; b), a species now recognizable by molecular methods (Johnson et al. 1997; Keis et al. 2001a).

Molasses-based media are generally deficient in available nitrogen and phosphate, which may be responsible for poor solvent production when *C. acetobutylicum* was tested in unfortified media in early studies, although the low buffering capacity of molasses may also be a factor. Good growth and solvent production in molasses-based media require the addition of a pH-control agent, vitamins, and mineral nutrients in addition to nitrogen and phosphorus compounds. In practice, ammonia (1.2–1.3 % NH₃ based on sugar concentration) was added both as a pH-control agent (when used in the form of ammonium hydroxide) and as a nitrogen

Table 2.3
Production of acetone, butanol, and ethanol from molasses in 90,000-l batch fermentation in South Africa^{a,b}

Product	Amount (kg)	Percent (wt/wt) of sugar fermented
Butanol	1,053	18
Acetone	526	9
Ethanol	175	3
Carbon dioxide	2,900	50
Hydrogen	117	2

^aThe 90,000-l batch contains 5,850 (approx.) kg of fermentable sugars from molasses

^b*Clostridium beijerinckii* strains NCP265 and NCP270 were used (Spivey 1978; Keis et al. 2001a). The fermentation medium was supplemented with corn-steep liquor, in addition to liquid ammonia, as a source of nitrogen and other growth stimulants to enhance solvent production. The starting pH was adjusted to 5.8–6.0 with ammonia, and calcium carbonate was added for its pH regulatory effect. The total cycle of cleaning, sterilization, filling, fermentation, and emptying the fermentor took 48 h, of which 30–34 h was fermentation time

Data from Spivey (1978)

source. Although ammonia alone gave satisfactory results, the use of ammonia plus a source of complex nitrogen (such as yeast water, corn-steep liquor, or stillage) was usually preferred in the fermentor medium to ensure a maximum yield of solvents (Beesch 1952). Superphosphate (depending on the manufacturing process, different preparations of superphosphate contain different amounts of the key ingredient, monobasic calcium phosphate, and other phosphorus compounds; the available amount of phosphorus in superphosphate is measured as P₂O₅) was used to give 0.05–0.2 % of P₂O₅ based on sugar (Walton and Martin 1979). **Table 2.3** shows the result of the molasses-based industrial fermentation used in South Africa in the 1970s.

Fermentable Substrates

Corn and molasses (sugarcane) were the principal raw materials for industrial solvent fermentation. Corn was primarily used during the era of the Weizmann process, which was based on *C. acetobutylicum*, whereas molasses was used when other bacteria replaced *C. acetobutylicum* in the industrial fermentation (see the section **“Industrial Solvent Fermentation”** in this chapter). Besides corn and molasses, other starchy substrates were also used in industrial solvent fermentation outside North America. For example, the raw materials for solvent production by “*Clostridium toanum* Baba” in Taiwan (Formosa) between 1947 and 1957 included sweet potato, casava, and wheat starch (a by-product of gluten production; Yeh 1955; Anonymous 1956; 1958). In addition, a diverse range of raw materials has been tested as alternative substrates for solvent production (McCutchan and Hickey 1954; Prescott and Dunn 1959a; Jones and Woods 1986; Dürre and Bahl 1996).

The succession of the corn- and the molasses-based fermentations implies that the molasses (sugar)-fermenting clostridia are not suitable for fermenting starchy substrates. In fact, starch is a fermentable substrate for strains of *C. aurantibutyricum*, *C. beijerinckii*, *C. saccharobutylicum*, and *C. saccharoperbutylacetonicum*, besides *C. acetobutylicum* (Cato et al. 1986; Keis et al. 2001a). Potatoes have been used successfully as a substrate for solvent production by *C. beijerinckii* NRRL B592 (Nimcevic et al. 1998), although partially hydrolyzed (liquefied) starch is preferred for operational reasons (Nimcevic and Gapes 2000). It is economically attractive to produce solvents from alternative substrates that are considered waste and normally present disposal problems. Besides potato waste (which includes industrial residues, low-grade potatoes, and spoiled potatoes; Nimcevic et al. 1998), other waste materials including cheese whey (Maddox 1980; Schoutens et al. 1984; Schoutens et al. 1985; Ennis and Maddox 1985; Stevens et al. 1988), hydrolyzed lignocellulosic and hemicellulosic materials (Compere and Griffith 1979; Compere et al. 1985; Fond et al. 1986a, b; Lemmel et al. 1986), palm oil mill effluent (Somrutai et al. 1996), apple pomace (Voget et al. 1985), and soy molasses (Qureshi et al. 2001) can be substrates for solvent production. The range of fermentable substrates for the solvent-producing clostridia is thus much broader than starch, sucrose, and their component sugars. A comprehensive review of the physiology of carbohydrate utilization by the solvent-producing clostridia is available (Mitchell 1998). A brief review of the properties of the polymers starch, cellulose, and xylan is given below, as these polymers represent potential substrates for future industrial solvent fermentation.

Starch is composed of amylose (a linear polymer of α -1,4-linked D-glucose residues) and amylopectin, which has α -1,6 linkages to connect branching linear chains. Endo-acting α -amylase randomly hydrolyzes α -1,4-D-glucosidic linkages in a chain containing three or more glucose units, with the reducing groups liberated in the α -configuration, whereas β -amylase hydrolyzes α -1,4-D-glucosidic linkages to remove successive β -maltose units from the nonreducing end. Glucoamylase hydrolyzes the terminal 1,4-linked α -D-glucose residues successively from the nonreducing ends, releasing β -D-glucose. The α -1,6 linkages at the branch points are hydrolyzed by pullulanase. Although starch was a major substrate for industrial solvent production, little is known about the amyolytic system in *C. acetobutylicum* or *C. beijerinckii*, and a consistent picture of the regulation of starch hydrolysis and metabolism is yet to emerge (Dürre and Bahl 1996; Mitchell 1998). An 84-kDa α -amylase has been purified from *C. acetobutylicum* ATCC 824 (Paquet et al. 1991), yet a cloned amylase gene from the organism encodes a 53.9-kDa polypeptide (Verhasselt et al. 1989), indicating that *C. acetobutylicum* ATCC 824 produces different amylases for the utilization of starch. Two α -amylase genes (CAP0098 and CAP0168) have been identified on the plasmid pSOL1 (Nölling et al. 2001), and they encode polypeptides of about 60 and 80 kDa, respectively.

Solvent-producing clostridia have not been reported to grow on cellulose, but the disaccharide cellobiose is metabolized by *C. acetobutylicum*, *C. aurantibutyricum*, *C. beijerinckii*, *C. saccharobutylicum*, and *C. saccharoperbutylacetonicum* (Cato et al. 1986; Keis et al. 2001a). Cellobiose is an excellent substrate for solvent production by *C. beijerinckii* NRRL B592 but not by *C. acetobutylicum* NRRL B527 (= ATCC 824) or *C. beijerinckii* NRRL B593 (Compere and Griffith 1979). Efficient degradation of crystalline cellulose requires cellulosomes (extracellular supramolecular structures composed of scaffold-bound endo- and exoglucosidases and cellulose-binding proteins; Mitchell 1998). Genes encoding at least 11 cellulosome component proteins have been identified in the genome of *C. acetobutylicum* ATCC 824 (Nölling et al. 2001). Inducible activities of endoglucanase (endoglucanase is endo-1,4- β -glucanase or 1,4-[1,3; 1,4]- β -D-glucan 4-glucanohydrolase) and cellobiase were in *C. acetobutylicum* NRRL B527 and ATCC 824 (Lee et al. 1985) and *C. beijerinckii* NCP270 (Allcock and Woods 1981). The endoglucanase hydrolyzes carboxymethyl cellulose, acid-swollen cellulose, and microcrystalline cellulose (Avicel) but not crystalline cellulose. Genes encoding an endoglucanase and a cellobiase have been cloned from *C. saccharobutylicum* NCP 262 (Zappe et al. 1986; 1988).

The solvent-producing clostridia can grow on xylan and pentoses (Cato et al. 1986; Mitchell 1998; Keis et al. 2001a) and produce moderate levels of solvents (Compere and Griffith 1979). Arabinose is an excellent substrate for solvent production by *C. beijerinckii* NRRL B592 but not for *C. acetobutylicum* NRRL B527 (= ATCC 824) or *C. beijerinckii* NRRL B593 (Compere and Griffith 1979). Pentoses are broken down by the transaldolase-transketolase pathway to produce fructose 6-phosphate and glyceraldehyde 3-phosphate, which are further metabolized via glycolysis to pyruvate before entering the acid- and solvent-producing pathways. A predicted operon (genes CAP0114 to CAP0120) consisting mostly of genes for xylan degradation has been identified on the pSOL1 plasmid of *C. acetobutylicum* ATCC 824 (Nölling et al. 2001). The gene encoding a xylanase has been cloned from *C. saccharobutylicum* NCP262 (Zappe et al. 1987).

For both hexoses and pentoses, the mono-, di-, and oligosaccharides and their derivatives are taken up via specific membrane-bound transport proteins. Few detailed studies of sugar uptake by the clostridia have been reported, but observations made to date indicate that the transport mechanisms are similar to those found in a wide variety of other bacteria (Mitchell 1998). A large number of genes for different types of transporters have been found in the genome of *C. acetobutylicum* ATCC 824 (Nölling et al. 2001).

Bacteriophage Infections, Autolysins, and Cell Lysis

Infections by bacteriophages were a recurrent problem for industrial solvent fermentation. The first phage

contamination incident on record occurred in 1923 (Ogata and Hongo 1979), in the Terre Haute (Indiana, United States) plant, and resulted in the halving of fermentation yields for about a year (Gabriel 1928). Many cases of such “sluggish fermentation,” experienced in the ensuing years, were presumed to be caused by phage infections. However, no proven case of phage contamination occurred until 1943 when McCoy and Sylvester reported the isolation of phages from fermentation broth from a plant in Puerto Rico that used “*Clostridium madisonii*,” a strain now recognized as *C. beijerinckii* (Ogata and Hongo 1979; Jones et al. 2000). A specific abnormal fermentation, called “sleeping sickness of acetone-butanol fermentation,” occurred at several factories in Japan around 1943, and incidences of such sleeping sickness or sluggish fermentation continued to occur for years. The review by Ogata and Hongo (1979) describes the isolation and characterization of phages from the abnormal fermentation broth as well as the selection of phage-resistant strains of clostridia for industrial uses.

By examining previously unreleased company reports and records, a review (Jones et al. 2000) provided information about phage infections at the National Chemical Products (NCP) factory, which produced solvents by fermentation from 1936 until 1982 in Germiston, South Africa. Confirmed or presumed phage infections of 1943, 1947, 1960, 1976, and 1980 at the NCP factory were described in this review, and the properties of the phage CA1 that caused the relatively mild 1980 phage infection were reported.

The characteristics of phage infections in solvent fermentation may be summarized as follows (Jones et al. 2000): Regardless of the bacterial strains or substrates used, the typical symptoms of phage-infected batches are slow or sluggish fermentations with extended fermentation times and reduced solvent yields. Because of a decrease in the metabolic and growth rates, the infected cultures produce less gas and leave more substrates unused. There are changes in the cell population and morphology that include a marked reduction in cell numbers, a loss of motility, and the presence of etched cells. In some cases, elongated cells or protoplasts may be observed. Lysis of infected cells can be observed in the laboratory but may not occur at the factory. Virulent, lysogenic, and pseudo-lysogenic phages have been identified, and they are quite strain specific. Of the seven phages that were tested against the strains of *C. acetobutylicum*, *C. beijerinckii*, *C. saccharobutylicum*, and *C. saccharoperbutylacetonicum*, all have restricted host ranges (Keis et al. 1995). At present, the selection of phage-resistant variants and the maintenance of good plant practice and hygiene remain the effective measures against phage infections. The selection and isolation of phage-resistant mutants or variants that retain solvent-producing capabilities are referred to as “phage immunization.” One danger of producing resistant strains is the possibility of generating lysogenic cultures, which may later release phage particles and continue to cause phage infections (Ryden 1958). It has been suggested that no matter how good the plant practice and hygiene, phage infections are bound to occur from time to time. It is therefore important that

companies operating this fermentation process develop strategies to minimize the impact of such infections (Jones et al. 2000).

Solvent-producing clostridia are also known to undergo autolysis as a result of lytic enzyme activity or bacteriocins with lytic activity (Barber et al. 1979; Allcock et al. 1981; Webster et al. 1981; van der Westhuizen et al. 1982; Roos et al. 1985; Croux et al. 1992a). Lysis of *C. acetobutylicum* ATCC 824 is stimulated by environmental conditions (e.g., pH 6.3, 55 °C, and the presence of monovalent cations; Croux et al. 1992a) and can be reduced by treatment with chloramphenicol (Zhou and Traxler 1992). The *lyc* gene (CAC0554) of *C. acetobutylicum* ATCC 824, which encodes an autolytic lysozyme (a muramidase acting on non-*n*-acetylated peptidoglycan; Croux et al. 1992b), has been cloned and characterized (Croux and Garcia 1991, 1992). When expressed in a recombinant strain of *Escherichia coli* under the control of the *lac* promoter, the autolytic lysozyme was secreted although it does not contain a cleavable signal peptide, suggesting that, like other autolysins, this lytic enzyme is also secreted through a specific mechanism (Croux and Garcia 1992a). The use of autolytic deficient mutants of solvent-producing clostridia may be a useful improvement for the industrial fermentation.

Physiology of Solvent Production

Butyric acid is a characteristic fermentation product of many anaerobic bacteria. In the carbohydrate-fermenting clostridia, the key metabolic intermediate pyruvate is cleaved by the pyruvate:ferredoxin oxidoreductase to acetyl-CoA and CO₂, with ferredoxin serving as the electron acceptor (Chen 1993). Two molecules of acetyl-CoA are combined by thiolase to form acetoacetyl-CoA, which is metabolized through the reactions catalyzed by enzymes 4 through 9 (Fig. 2.1) to form a molecule of butyric acid, with the concomitant consumption of two molecules of reduced nicotinamide adenine dinucleotide (NADH) or reduced nicotinamide adenine dinucleotide phosphate (NADPH) and the production of an ATP. During the exponential phase of growth, acetic acid is produced in addition to butyric acid, and the acetate-producing pathway could be viewed as a branch of the butyrate-producing pathway (Fig. 2.1). Acetyl-CoA is thus the branch-point between the acetate- and the butyrate-producing pathways. The production of butanol and acetone/isopropanol, on the other hand, involves regulated metabolic pathways that branch off the butyrate-producing pathways at the C₄-intermediates butyryl-CoA and acetoacetyl-CoA, respectively (Fig. 2.1). The accumulation of solvents in the culture medium occurs late during growth of *C. acetobutylicum* as shown in Fig. 2.2. Other solvent-producing species exhibit a similar time course (Rogers 1986; Yan et al. 1988), suggesting that solvent production is a programmed response to either specific environmental conditions or growth-stage related signals.

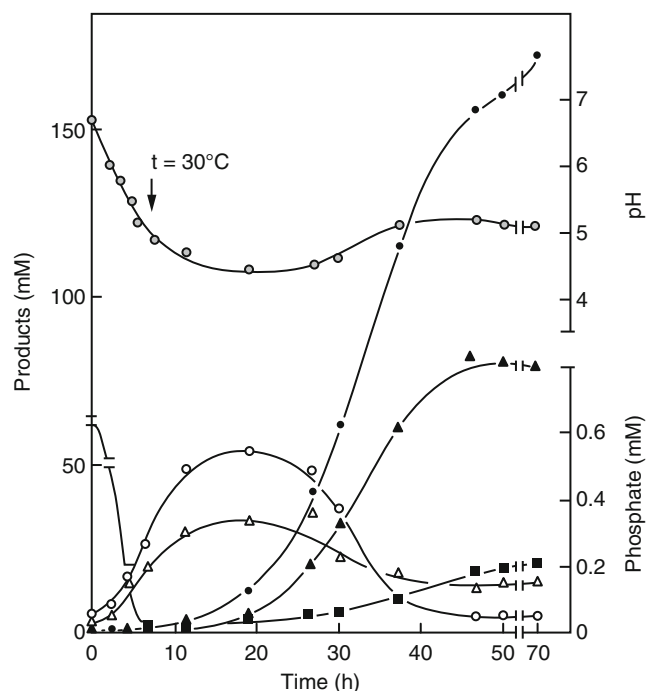

Fig. 2.2

Time course of acid production and subsequent solvent accumulation with concurrent acid reutilization in a batch culture of *C. acetobutylicum* DSM 1731. The mineral medium contained 60 g/l of glucose and a low concentration (0.62 mM) of phosphate. The temperature was 37 °C during the exponential phase of growth, and the pH was regulated to allow it to decrease linearly from 6.6 to 5.0. When phosphate was exhausted in the medium and the pH was below 5.0, the temperature was lowered to 30 °C and the pH regulation was switched off. The final concentrations (mM) after 3 days were: butanol, 175; acetone, 77; ethanol, 22; butyrate, 9; acetate, 18; acetoin, 9; glucose, 0; and phosphate, 0. Symbols: butanol, ●; acetone, ▲; ethanol, ■; butyrate, ●; acetate, △; phosphate, □; and pH, s (From Bahl et al. 1982a)

Initiation of Solvent Production

In batch cultures, the start of solvent production by wildtype cells requires a variety of environmental conditions, including a high concentration of butyric acid, a low culture pH, and a growth-limiting concentration of phosphate or sulfate. These conditions are associated with changes in carbon and electron flux and in concentrations of high-energy intermediates in the cell, and the growth rate decreases under such environmental conditions. One or several of the environmental conditions determine the accompanying cellular conditions present shortly before the start of active solvent production, and the extracellular and intracellular conditions directly or indirectly serve as signals for activating the transcription of the solvent-production genes and result in a metabolic switch from acid to solvent production. Although the solventogenic switch clearly involves events at the transcriptional level (Dürre et al. 2002), the

molecular mechanism for activating the transcription of solvent-production genes remains to be elucidated. It has been suggested that because the environmental conditions required for solvent production can affect DNA topology directly, a relaxation of the degree of negative DNA supercoiling might be the trigger for solvent-production gene activation (Dürre et al. 1995; Dürre 1998). However, specific regulatory (effector) proteins apparently play important roles in the transcriptional activation of solvent-production genes inasmuch as conserved motifs have been identified in the promoter region of solvent-production operons (Ravagnani et al. 2000; Thormann et al. 2002). In addition, different carboxylic acids affect the initiation of transcription of the solvent-production genes differently, suggesting a specificity of the sensor proteins toward the solventogenic signals.

In a glucose-limited continuous culture maintained at pH 4.3 and with an excess of phosphate, the presence of butyric acid at 20 mM or above allowed *C. acetobutylicum* DSM 1731 to produce solvents (Bahl et al. 1982a). In batch cultures (Husemann and Papoutsakis 1986) or with washed logarithmic growth-phase cells (Ballongue et al. 1985), addition of butyrate (6–20 mM), acetoacetate (12–20 mM), acetate (8–33 mM), and several other C₁ to C₄ straight-chain acids can induce the solventogenic transition in *C. acetobutylicum* ATCC 824. When the culture pH was maintained at 6 and the starting glucose concentration was about 275 mM (about 5 %, w/v), solvent production by *C. acetobutylicum* ATCC 824 was observed when 65 mM of butyrate was added early during growth, but it ceased immediately upon glucose depletion (Husemann and Papoutsakis 1988). The addition of butyrate plus acetate accelerated *C. beijerinckii* strain NRRL B592 (George and Chen 1983) and strain NCIMB 8052 (Holt et al. 1984) into the solventogenic transition at neutral pH, but the addition of butyrate or acetate alone was not effective (George and Chen 1983). Among the carboxylic acids tested, citric acid (Husemann and Papoutsakis 1986) and straight-chain carboxylic acids with 5–7 carbon atoms and branched-chain acids (Ballongue et al. 1985) could not induce the solventogenic transition. The specificity toward the straight-chain C₁ to C₄ carboxylic acids indicates that it is not the acid-base properties of the carboxylic acids that are responsible for their solventogenic triggering effect. Furthermore, specific enzymes or sensors must be involved in transducing the external signal to the transcriptional apparatus.

The concentration of total or undissociated butyric or acetic acid at the onset of solvent production has been the subject of a number of investigations as this parameter is likely a quantitative triggering signal for solventogenesis. Depending on the medium composition and other growth conditions used, the concentration of undissociated butyric acid at the onset of solvent production by *C. acetobutylicum* ranged from about 5–20 mM when the culture pH was below 5.5 (Monot et al. 1984; Terracciano and Kashket 1986; Husemann and Papoutsakis 1988) and below 5 mM when the culture pH was controlled at 6 (Husemann and Papoutsakis 1988). A correlation was not found between the onset of solvent production and the external

pH, the intracellular pH, the pH difference across the cytoplasmic membrane, and the external and intracellular butyrate and acetate concentrations (Husemann and Papoutsakis 1988). The correlation between the concentration of undissociated butyric acid and the onset of solvent production is not absolute, and it may reflect a combined effect of the pH and the dissociated butyric acid concentration on solventogenesis (Husemann and Papoutsakis 1988), as the undissociated butyric acid is a biochemically inert species (Gottwald and Gottschalk 1985).

Although the time course of fermentation is similar among different species of solvent-producing clostridia, suggesting a common regulatory mechanism for solventogenesis, there are qualitative or quantitative differences in the response exhibited by different solvent-producing species to the same set of environmental signals. A prominent example is the different pH-dependence for the onset or progress of solvent production (Johnson and Chen 1995). In laboratory media, a pH of 5.5 or below is usually considered necessary for *C. acetobutylicum* to show sustained solvent production, and an optimal pH of 4.3 was reported for *C. acetobutylicum* strains DSM 792 and 1731. *C. acetobutylicum* ATCC 824 produced 48-mM butanol and 27-mM acetone when the culture pH was controlled at 6 and the initial glucose concentration was about 550 mM (about 10 %, w/v), whereas it produced little butanol or acetone at pH 6 when the initial glucose concentration was about 275 mM (Husemann and Papoutsakis 1988). In contrast, *C. beijerinckii* NRRL B592 produced these solvents at pH 6.8 with an initial sucrose concentration of 6 % (w/v) and without butyrate supplementation (George and Chen 1983). *Clostridium saccharobutylicum* NCP262 (formerly *C. acetobutylicum* P262) produced these solvents at pH 5.5–6.5, but not when the pH of the culture was allowed to drop below 4.5 during the early part of the fermentation (Jones and Woods 1986).

In batch or continuous cultures of *C. acetobutylicum* DSM 1731, phosphate limitation (initial phosphate concentrations between 0.62 and 0.74 mM) has a profound effect on enhancing the consumption of glucose and production of solvents (Bahl et al. 1982b). The onset of solvent production coincided with the exhaustion of phosphate in the medium and with the culture pH falling below 5.

Among the conditions conducive to the onset of solvent production, a high concentration of acids is effective with different species of clostridia. It is interesting to note that the practice of “slopback” (the reuse of the hot stillage [i.e., the fermentation broth after the removal of cells and solvents] to substitute for 10–100 % of the volume of water in the fermentor medium) during industrial solvent production resulted in a slightly faster fermentation (McCutchan and Hickey 1954) and also an increase in yield of solvents (Beesch 1952, 1953; Walton and Martin 1979). Slopback was practiced to lower the water usage, the cost of heating, and the cost of waste disposal. However, it could also be a source of butyric and acetic acids in each batch of fermentor medium. The actual concentrations of butyrate and acetate in the stillage are not clear but could be

estimated. When batch cultures of *C. acetobutylicum* DSM 1731 were grown for 3 days in a medium containing 60 g/l of glucose and either a low (0.62 mM) or a high (12.25 mM) concentration of phosphate, the final butyrate and acetate concentrations were 9 and 18 mM, respectively, for the low-phosphate culture, and 68 and 42 mM, respectively, for the high-phosphate culture, whereas the final butanol concentrations were 175 and 47 mM, respectively, for the two cultures (Bahl et al. 1982b). The concentrations of butyrate and acetate in stillage might be within this range.

The onset of solvent production by PJC4BK strains of *C. acetobutylicum* ATCC 824 (these mutant strains have the butyrate kinase, *buk*, gene in the *ptb-buk* locus inactivated) occurs during the exponential phase of growth (Green et al. 1996; Harris et al. 2000). The total external butyric acid concentration was 1 mM, and the undissociated butyric acid concentration was estimated at 0.4 mM when butanol (about 2 mM) was first detected (Harris et al. 2000). These observations suggest that a high concentration of butyrate (or its transport) is not involved in triggering the onset of solvent production. Because these mutant strains have a lowered level of butyrate kinase (*C. acetobutylicum* ATCC 824 has a second butyrate kinase gene; see the section [▶ “Genes and Operons for Solvent Production and the Genome of Solvent-Producing Bacteria”](#) in this chapter), it is postulated that the accumulation of butyryl phosphate or butyryl-CoA might be responsible for triggering solvent production, as previously suggested (Gottwald and Gottschalk 1985). When the butyrate kinase level was lowered by the antisense RNA technique (see section [▶ “Genes and Operons for Solvent Production and the Genome of Solvent-Producing Bacteria”](#) in this chapter), the peak and final butyrate concentrations were actually higher than that of the control culture (Desai and Papoutsakis 1999). Because of the high butyrate concentration produced in the presence of anti-*buk*-RNA, it is unclear what triggers the earlier onset of solvent production in the presence of anti-*buk*-RNA.

Relationship to Sporulation

Although solvent production can be observed in exponentially growing cells, significant solvent accumulation occurs in cells beyond the logarithmic phase of growth. The duration of solvent production indeed has a close temporal relationship to growth stages, especially sporulation. Weizmann is credited with the discovery of a correlation between a strain's ability to sporulate and its ability to produce solvents as he used repeated pasteurization (100–150 cycles) to select heat-resistant spores for selecting and preserving a productive strain (Prescott and Dunn 1959a). McCoy and Fred (1941) reported the result of a serial transfer experiment that lasted over 2 years. When three pure cultures were subjected to 150 cycles of the Weizmann procedure (pasteurization at 100 °C for 1–2 min at intervals of 4–5 days to allow spore formation), the initial solvent yield was 26.2 % and the final solvent yield was 24.7 %, and the ratio of

solvents was unchanged. On the other hand, when a strain was subjected to 200–300 transfers using vegetative cells (transfers were made at 12- and 24-h intervals), degeneration was observed by the 10–20th transfer. The solvent yield usually dropped to 0.5–2 % before the 50th transfer, and spore formation was almost completely lost.

It is now established that an early step(s) of the switch for solvent production and sporulation is activated by a shared regulatory element. The Spo0A protein has been found to control the switch from acid to solvent production in *C. acetobutylicum* and *C. beijerinckii* (Ravagnani et al. 2000; Harris et al. 2002; Thormann et al. 2002). In *Bacillus subtilis*, the phosphorylated Spo0A protein plays a crucial role both as a negative and as a positive effector of gene expression at early times in the sporulation gene activation program (Balducci et al. 1994). Sequences resembling the Spo0A-binding motif (the OA box) 5'-TGTCGAA are present in either orientation in the promoter region of the solvent-production operons and are required for transcriptional activation. However, additional upstream sequences are also required for the transcription of the *adhE* gene of *C. acetobutylicum* DSM 792, indicating the involvement of additional transcription effectors for solvent production (Thormann et al. 2002).

Because solvent production and sporulation share a key regulatory element for an early part of the two processes, mature spores are a good source of cells competent for solvent production. However, some asporogenous mutants are able to produce solvents (Meinecke et al. 1984). This is consistent with the interpretation that only an early step(s) of sporulation and solvent production depends on the common regulatory element Spo0A for transcriptional activation, and mutations disabling reactions specific for the late stages of sporulation should not affect solvent production. In fact, even the mutant strain of *C. acetobutylicum* ATCC 824, whose *spo0A* gene was inactivated, expressed the solvent-production genes to a limited extent and produced low levels of acetone and butanol (Harris et al. 2002), indicating that the transcription of the solvent-production genes is greatly enhanced by but not absolutely dependent on Spo0A. Because of the shared regulatory element, cells entering the solvent-producing stage are also entering sporulation, resulting in the formation of resting cells. Therefore, the shared regulatory circuit between solvent production and sporulation effectively sets a practical limit on the duration of active solvent production, regardless of the toxicity of the fermentation products. Because some asporogenous mutants of *C. acetobutylicum* are solvent producers (see the section [▶ “Strain Degeneration”](#) in this chapter), it may be useful to identify factors that limit the duration of solvent production in these asporogenous mutants. The observation that solvent production by *C. beijerinckii* NRRL B592 is enhanced by high glucose but low yeast extract concentrations (conditions that appear to slow down growth and acid production) and that acid and solvent production can proceed simultaneously (Maddox et al. 2000) suggests that a combination of genetic manipulation and process engineering may significantly prolong solvent production in batch cultures.

Product Pattern

As might be predicted from the metabolic pathways shown in [Fig. 2.1](#), the ratio of butanol to acetone (or isopropanol) produced by a culture can be expected to vary under different growth conditions. The determining factors could include the level of specific enzymes present, the availability of specific substrates, the supply of reducing power, and the activity of regulatory molecules. The production of acetone depends on the activity of acetoacetate: butyrate/acetate CoA-transferase (see the section [“Metabolic Pathways and Enzymology of Solvent Production”](#) in this chapter) and is hence directly linked to the uptake of butyrate and acetate via CoA-transferase. The uptake of one butyrate or acetate molecule via CoA-transferase results in the production of one acetoacetate molecule, which leads to the production of one acetone molecule. Butyrate taken up via butyrate kinase does not contribute to the production of acetone because it generates butyryl-CoA, whereas acetate taken up via acetate kinase might contribute to acetone production if the resulting acetoacetyl-CoA is metabolized by CoA-transferase with the consumption of additional acids. Addition of acetate, or the practice of slopback, is thus known to boost acetone production. The production of butanol and isopropanol requires reducing power and is limited to the period when cells metabolize (oxidize) carbohydrates actively.

In industrial solvent fermentation using *C. acetobutylicum*, the product ratio (based on weight) is usually reported as butanol: acetone: ethanol (6: 3: 1; Gabriel 1928; McCutchan and Hickey 1954). However, the butanol: acetone: ethanol ratio can range from 76.1: 17.9: 6.0 or 75.6: 22.4: 2.0 to 60: 38: 2 with different organisms grown under different conditions (McCutchan and Hickey 1954). On the basis of sugar consumed, the solvent yield is about 30 % (w/w), and it can be nearly quantitative on the mol/mol basis. With slopback, solvent yields are generally about 34 % (w/w; McCutchan and Hickey 1954). Although butanol is toxic to the solvent-producing clostridia (Moreira et al. 1981; Bowles and Ellefson 1985; for a discussion of cellular toxicity of alcohols, see “Ethanol” in Organic Acid and Solvent Production, Part II in this volume), the final concentration of butanol in an industrial fermentation broth is not the highest that could be reached. Instead, it is purposely controlled by the use of a limited amount of carbon substrate so that a batch of fermentation is completed within a desirable period of time and little unused carbon substrate remains in the medium at the end. Whether butanol toxicity affects the progression of sporulation remains to be determined.

Alcohologenic Mode of Growth

The production of both acetone and butanol by *C. acetobutylicum* is a characteristic of this species, and the two products are responsible for the organism's continued usefulness during and after World War I. Interestingly, under certain growth conditions, a different mode of fermentation

(i.e., production of only butanol and ethanol) by this organism was discovered. Butanol but not acetone is produced when the culture pH is at or above 5.5 (Peguín et al. 1994; Girbal et al. 1995a). The term “alcohologenic” applies to the mode of fermentation that produces only the alcohols butanol and ethanol (Girbal and Soucaille 1994). Growth conditions leading to alcohologenesis include the addition of methyl or benzyl viologen to the medium (Rao and Mutharasan 1987, 1988; Grupe and Gottschalk 1992; Peguín et al. 1994; Dürre et al. 1995; Sauer and Dürre 1995), the addition of neutral red to the medium at neutral pH (Girbal et al. 1995b), and the addition of glycerol or glycerol plus pyruvate to a glucose-containing medium (Girbal and Soucaille 1994; Vasconcelos et al. 1994). During alcohologenesis, the two acetone-producing enzymes, CoA-transferase and acetoacetate decarboxylase, are not detected (Dürre et al. 1995). It is now known that *C. acetobutylicum* has a second aldehyde-alcohol dehydrogenase that is encoded by the *adhE2* gene (CAP0035; see the section [“Genes and Operons for Solvent Production and the Genome of Solvent-Producing Bacteria”](#) in this chapter), and during the alcohologenic mode of growth, butanol and ethanol production is catalyzed by AdhE2 (Fontaine et al. 2002).

Strain Degeneration

The solvent-producing clostridia gradually lose their productivity when cells are kept in the vegetative stage for a prolonged period of time (i.e., through serial transfers using growing cells as the inoculum), and this phenomenon is known as “degeneration” (McCoy and Fred 1941; Kutzenok and Aschner 1952). Strain degeneration is the result of genetic alterations, and it can be distinguished from the occasional failure of a culture to produce solvents because the growth conditions are unfavorable for sustained solvent production (Maddox et al. 2000). To clearly separate temporary, environmentally caused poor productivity from genetically based strain degeneration, the terms “acid crash” and “acidogenic fermentation” have been proposed (Maddox et al. 2000). Acid crash describes the early cessation of sugar uptake and solvent production when a culture is under a condition (pH below 5 for *C. beijerinckii* NRRL B592) that allows the concentration of undissociated acetic and butyric acids to exceed a threshold level, whereas acidogenic fermentation describes fast growth, sugar utilization, and acid production but slow solvent production when the pH of the culture is kept near neutrality and when yeast extract is present in ample amounts.

To circumvent deterioration of the strains for industrial fermentation, spores were preserved as the stock and repeated pasteurization was performed to select cells competent for solvent production (McCoy and Fred 1941). The fact that a selection for mature spores also selects cells competent for solvent production indicates that a major mechanism

for degeneration is sporulation related (see the section [▶ “Relationship to Sporulation”](#) in this chapter).

Degeneration occurs more readily in *C. beijerinckii* than in *C. acetobutylicum* (Woolley and Morris 1990). In continuous cultures, asporogenous mutants of *C. acetobutylicum* DSM 1731 are readily selected (Meinecke et al. 1984). Some asporogenous mutants from the continuous culture reverted to become sporeformers; however, after prolonged growth (35 days) in a continuous culture, a stable asporogenous mutant of *C. acetobutylicum* DSM 1731 became established, but it produced butanol and acetone as the major products. When asporogenous mutants of *C. beijerinckii* NCIMB 8052 were selected in continuous cultures, they degenerated into solvent-nonproducing strains (Woolley and Morris 1990). These mutants spontaneously reverted at a low frequency to the parental phenotype (positive for sporulation, granulose synthesis, and solvent production), indicating that the multiple loss of capacities is the pleiotropic consequence of a lesion in some global regulatory gene. The discovery of the involvement of the Spo0A protein in the initiation of solvent production could explain the pleiotropic effect of a single mutation on both solvent production and sporulation (see the section [▶ “Relationship to Sporulation”](#) in this chapter). However, because the molecular change(s) causing degeneration has not been characterized, it is still not known precisely how strain degeneration occurs.

Maintenance of cells in the vegetative state for a prolonged period, either by serial transfers or by continuous cultures, results in cultures of predominantly degenerated cells. During the transition into a culture of degenerated cells, the cell density and the rate of sugar metabolism decrease (Stephens et al. 1985). Interestingly, by maintaining a high cell density in a continuous culture (Stephens et al. 1985) or during serial transfers (Chen and Blaschek 1999b), the rate of degeneration decreased. The turbidometric technique (Stephens et al. 1985) or the addition of acetate (Chen and Blaschek 1999b) was used to maintain a high cell density. A mutant strain of *C. beijerinckii* NCIMB 8052 with a truncated peptide deformylase has a slower growth rate and a decreased tendency to undergo degeneration (Evans et al. 1998). The procedures for reducing the rate of degeneration, together with the identification of Spo0A as a key regulator for the initiation of solvent production, should help efforts to elucidate the mechanisms of degeneration and the solventogenic switch.

When compared with the parental strains, the degenerated cells exhibited several different physical and morphological characteristics that may facilitate the detection of degeneration during the preparation of seed cultures for an industrial fermentation. The degenerated cells of *C. beijerinckii* and *C. saccharobutylicum* tend to give larger and translucent colonies with an irregular shape (Adler and Crow 1987; Woolley and Morris 1990; Schuster et al. 2001), a longer but thinner cell shape (Adler and Crow 1987), and a characteristic infrared spectrum (Fourier transform IR) that is distinguishable from the spectra of parental cells at different stages of growth (Schuster et al. 2001).

Metabolic Pathways and Enzymology of Solvent Production

The general features of the metabolic pathways ([▶ Fig. 2.1](#)) for solvent production have been known for some time (Rogers 1986; Jones and Woods 1986). The enzymology of solvent production was studied mostly with *C. acetobutylicum* and *C. beijerinckii* (Chen 1993; Bennett and Rudolph 1995; Dürre and Bahl 1996), but because of the multiplicity of alcohol and aldehyde dehydrogenases in the solvent-producing clostridia (Chen 1995), the specific role for each alcohol or aldehyde dehydrogenase in the formation of butanol or ethanol is still a subject of research. The genes encoding the specific solvent-forming enzymes (14–20 in [▶ Fig. 2.1](#)) and the enzymes for the conversion of acetyl-CoA to butyryl-CoA (4–7 in [▶ Fig. 2.1](#)), which are required for both acid and solvent production, have been cloned and sequenced (see below and the section [▶ “Genes and Operons for Solvent Production and the Genome of Solvent-Producing Bacteria”](#) in this chapter). The specific acid-forming reactions (8–11 in [▶ Fig. 2.1](#)) are also important to solvent production because the accumulation of acetate and butyrate during the exponential phase of growth plays a regulatory role in the solventogenic switch (see the section [▶ “Physiology of Solvent Production”](#) in this chapter) and the accumulated acetate and butyrate are reutilized through the activity of the CoA-transferase (16 in [▶ Fig. 2.1](#)) essential to acetone/isopropanol formation.

In the acid- and solvent-producing pathways, three CoA-derivatives (acetyl-CoA, acetoacetyl-CoA, and butyryl-CoA) occupy branch points, and enzymes acting on these branch-point intermediates likely play a pivotal role in regulating the flux of carbon into each specific branch and end product. Three enzymes (thiolase, enzyme 4 in [▶ Fig. 2.1](#); phosphotransacetylase, enzyme 10; and aldehyde (acetaldehyde) dehydrogenase, enzyme 19) react with acetyl-CoA, and their relative activities control the amount of acetyl-CoA that is available for the C₂ products (ethanol and acetate) or the C₄ intermediate acetoacetyl-CoA, which is the precursor for acetone/isopropanol, butanol, and butyrate. Two enzymes (3-hydroxybutyryl-CoA dehydrogenase, enzyme 5; and acetoacetate:acetate/butyrate CoA-transferase, enzyme 16) react with acetoacetyl-CoA and control the amounts of C₃ (acetone/isopropanol) and C₄ (butanol and butyrate) products formed. Two enzymes (phosphotransbutyrylase, enzyme 8; and aldehyde [butyraldehyde] dehydrogenase, enzyme 14) react with butyryl-CoA and control the amounts of butanol and butyrate produced. The acid- and solvent-producing reactions are linked to ATP formation and NAD (P)⁺ regeneration. Therefore, the substrate and product concentrations, the energy and redox states, and other cellular conditions can all affect the activities of the branch-point enzymes. Knowledge about the regulatory properties of these enzymes is useful in attempts to control the product ratio of solvent fermentation. The results of in vitro kinetic measurements predict that the activities of these enzymes are subject to regulation by pertinent metabolic intermediates, but in vivo

data are difficult to obtain (Chen 1993; Bennett and Rudolph 1995; Dürre and Bahl 1996). The following is a summary of the properties of these enzymes and their structural genes.

Thiolase

The condensation of two acetyl-CoA molecules into acetoacetyl-CoA by thiolase (acetyl-CoA:acetyl-CoA C-acetyltransferase; enzyme 4 in [Fig. 2.1](#)) is an essential step for the formation of the C₄ precursor for acetone/isopropanol, butanol, and butyrate. The reaction is therefore required for both the acid- and the solvent-producing stages of growth. Thiolase has been purified to different degrees of purity from several *Clostridium* species (Chen 1993; Bennett and Rudolph 1995). From *C. acetobutylicum* ATCC 824, thiolase has been purified 70-fold to homogeneity, and it has a subunit mol. wt. (MW) of 44 kDa and a native MW indicative of a homotetrameric structure (Wiesenborn et al. 1988). The purified thiolase is sensitive to inhibition by micromolar levels of CoASH in the direction of acetyl-CoA condensation, and it is also inhibited by ATP and butyryl-CoA. The *C. acetobutylicum* thiolase shows a high activity in the pH range of 5.5–7.0. It has been suggested that the relative amounts of CoASH and acetyl-CoA regulate the activity of thiolase (Wiesenborn et al. 1988).

The structural gene for the purified thiolase of *C. acetobutylicum* ATCC 824 has been cloned and sequenced (Stim-Herndon et al. 1995), and it encodes a polypeptide of 392 amino acids (calculated MW 41,237). The genome of *C. acetobutylicum* ATCC 824 contains two thiolase genes, with *thlA* located on the chromosome (CAC2873, denoting the gene number on the annotated chromosome sequence) and *thlB* located on the plasmid pSOL1 (CAP0078, denoting the gene number on the annotated plasmid sequence). The *thlA* gene encodes the purified thiolase, and its level of transcription reached a transient minimum 3–7 h after a continuous culture of *C. acetobutylicum* DSM 792 was induced for solvent production (Winzer et al. 2000). The *thlB* gene had a very low level of expression in both acid- and solvent-producing cells, and its physiological function is unknown. The transient decrease in the level of transcription of the *thlA* gene between the acid- and solvent-producing stages of growth may explain the observed variation in the level of thiolase activity in acid- and solvent-producing cells (Chen 1993).

3-Hydroxybutyryl-CoA Dehydrogenase

In the solvent-producing clostridia, 3-hydroxybutyryl-CoA dehydrogenase (β -hydroxybutyryl-CoA dehydrogenase; enzyme 5) catalyzes the reduction of acetoacetyl-CoA to 3-hydroxybutyryl-CoA. The enzyme has been purified from *C. beijerinckii* NRRL B593, and it has subunit and native MWs of 30.8 and 213 kDa, respectively (Colby and Chen 1992). The enzyme can use either reduced nicotinamide adenine dinucleotide (NADH) or NADPH as a cosubstrate, but NADH gives a 60-fold higher catalytic efficiency and is likely the physiological cosubstrate.

The structural gene (*hbd*) for the enzyme of three solvent-producing clostridia has been sequenced. The length (number of amino acid residues) of the deduced polypeptide and its calculated MW are: *C. acetobutylicum* [<http://www.ncbi.nlm.nih.gov/entrez/query.fcgi?cmd=Search%26db=Nucleotide%26term=ATCC824%26doptcmdl=DocSum>] {ATCC824}], 282 and 30,500 (Boynton et al. 1996a); *C. beijerinckii* NRRL B593, 281 and 30,167 (J. Toth and J.-S. Chen, GenBank accession number [<http://www.ncbi.nlm.nih.gov/entrez/query.fcgi?cmd=Search%26db=Nucleotide%26term=AF494018%26doptcmdl=DocSum>] {AF494018}]); and *C. saccharobutylicum* NCP262 (formerly *C. acetobutylicum* P262), 282 and 31,435 (Youngleson et al. 1989). The *C. acetobutylicum hbd* gene is designated CAC2708 on the annotated genome sequence. The amino acid sequence of 3-hydroxybutyryl-CoA dehydrogenase among these three species is highly conserved throughout the length of the polypeptide, with the *C. beijerinckii* enzyme shortened by one amino acid at the C-terminus (J.-S. Chen and J. Toth, unpublished results). The *hbd* gene is part of the BCS (butyryl-CoA synthesis) operon (see the section [“Genes and Operons for Solvent Production and the Genome for Solvent-Producing Bacteria”](#) in this chapter).

Crotonase

In the solvent-producing clostridia, crotonase (enoyl-CoA hydratase; enzyme 6 in [Fig. 2.1](#)) catalyzes the dehydration of 3-hydroxybutyryl-CoA to form crotonyl-CoA. Crotonase has been purified 131-fold (67 % yield) to homogeneity from *C. acetobutylicum* (probably strain NRRL B528, as spores were provided by I. Fridovich whose laboratory used this strain; Waterson et al. 1972). The purified enzyme is active only toward C₄ and C₆ substrates, and it has a native MW of 158 kDa and a subunit MW of 40 kDa. The predicted structural gene (*crt*; CAC2712) for *C. acetobutylicum* ATCC824 encodes a polypeptide of 261 amino acids, with a predicted MW of 28.2 kDa (Boynton et al. 1996a). The predicted *crt* gene of *C. beijerinckii* NRRL B593 also encodes a polypeptide of 261 amino acids (predicted MW 28,180; J. Toth and J.-S. Chen, GenBank accession number [<http://www.ncbi.nlm.nih.gov/entrez/query.fcgi?cmd=Search%26db=Nucleotide%26term=AF494018%26doptcmdl=DocSum>] {AF494018}]). The *crt* genes of *C. acetobutylicum* [<http://www.ncbi.nlm.nih.gov/entrezquery.fcgi?cmd=Search%26db=Nucleotide%26term=ATCC824%26doptcmdl=DocSum>] {ATCC824}] and *C. beijerinckii* NRRL B593 occupy a similar location in the BCS operon, which consists of five genes for the synthesis of butyryl-CoA (see the section [“Genes and Operons for Solvent Production and the Genome for Solvent-Producing Bacteria”](#) in this chapter).

Butyryl-CoA Dehydrogenase

In the solvent-producing clostridia, butyryl-CoA dehydrogenase (enzyme 7 in [Fig. 2.1](#)) catalyzes the reduction of crotonyl-CoA

to butyryl-CoA. Butyryl-CoA dehydrogenase has not been purified from the solvent-producing clostridia, and results from studies using cell-free extracts of the clostridia suggest that the immediate electron donor for the enzyme is not NADH or NADPH (Chen 1993; Boynton et al. 1996a). The structural gene (*bcd*) for the butyryl-CoA dehydrogenase of *C. acetobutylicum* and *C. beijerinckii* has been identified from its conserved amino acid sequence and location in the BCS operon (see the section [“Genes and Operons for Solvent Production and the Genome of Solvent-Producing Bacteria”](#) in this chapter). The predicted *bcd* gene (CAC2711) of *C. acetobutylicum* ATCC824 encodes a polypeptide of 379 amino acids (predicted MW 41,386; Boynton et al. 1996a). The predicted *bcd* gene of *C. beijerinckii* NRRL B593 also encodes a polypeptide of 379 amino acids (predicted MW 41,045; J. Toth and J.-S. Chen, GenBank accession number [[{http://www.ncbi.nlm.nih.gov/entrez/query.fcgi?cmd=Search%26db=Nucleotide%26term=AF494018%26doptcmdl=DocSum}](http://www.ncbi.nlm.nih.gov/entrez/query.fcgi?cmd=Search%26db=Nucleotide%26term=AF494018%26doptcmdl=DocSum)] {AF494018})).

Two open-reading frames (CAC2709 and CAC2710) are present between the *bcd* and *hbd* genes of the BCS operon of *C. acetobutylicum* [[{http://www.ncbi.nlm.nih.gov/entrez/query.fcgi?cmd=Search%26db=Nucleotide%26term=ATCC824%26doptcmdl=DocSum}](http://www.ncbi.nlm.nih.gov/entrez/query.fcgi?cmd=Search%26db=Nucleotide%26term=ATCC824%26doptcmdl=DocSum)] {ATCC824}], and they were identified as the *etfA* (syn. *fixB*) and *etfB* (syn. *fixA*) genes that code for the subunits of an electron-transferring flavoprotein (ETF; Boynton et al. 1996a). Two corresponding ORFs occur between the *bcd* and *hbd* genes of the BCS operon of *C. beijerinckii* NRRL B593 (J. Toth and J.-S. Chen, GenBank accession number [[{http://www.ncbi.nlm.nih.gov/entrez/query.fcgi?cmd=Search%26db=Nucleotide%26term=AF494018%26doptcmdl=DocSum}](http://www.ncbi.nlm.nih.gov/entrez/query.fcgi?cmd=Search%26db=Nucleotide%26term=AF494018%26doptcmdl=DocSum)] {AF494018}) or preceding the *hbd* gene in *C. saccharobutylicum* NCP262 (formerly *C. acetobutylicum* P262; Youngleson et al. 1995). The ETF of the butyric acid-producing anaerobic bacterium *Megasphaera elsdenii* has been purified and characterized (Whitfield and Mayhew 1974), and it mediates electron transfer between NADH and butyryl-CoA dehydrogenase. The *M. elsdenii* ETF is a heterodimer, with the *etfA* and *etfB* genes encoding, respectively, the α - (338 amino acids; MW 36,101) and β - (270 amino acids; MW 29,081) subunits (O'Neill et al. 1998). The *etfA*- and *etfB*-encoded polypeptides of the solvent-producing clostridia are similar in size and amino acid sequence to, respectively, EtfA and EtfB of *M. elsdenii*. It may be postulated that in the solvent-producing clostridia, the *etfA* and *etfB* genes encode an ETF that is the electron donor for the butyryl-CoA dehydrogenase.

Aldehyde Dehydrogenase

Aldehyde dehydrogenase (ALDH; enzymes 14 and 19 in [Fig. 2.1](#)) is responsible for the formation of butyraldehyde from butyryl-CoA and acetaldehyde from acetyl-CoA for the production of, respectively, butanol and ethanol. Different ALDH activities can be measured in a strain of solvent-producing clostridia (Bertram et al. 1990), and the

ALDH activity can reside in distinct proteins in different species of solvent-producing clostridia (Toth et al. 1999). A biochemically similar ALDH has been purified from *C. saccharobutylicum* NRRL B643 (formerly *C. acetobutylicum* NRRL B643; Palosaari and Rogers 1988) and *C. beijerinckii* strains NRRL B592 (Yan and Chen 1990) and NRRL B593 (Toth et al. 1999). The ALDH from these two species has a native MW of 100–115 kDa and a subunit MW of 55–56 kDa. NADH is a more efficient cosubstrate than NADPH, and butyryl-CoA is a better substrate than acetyl-CoA for these ALDHs. The gene (*ald*) encoding the ALDH has been cloned from two strains of *C. beijerinckii* and sequenced (Toth et al. 1999; Hong 1999). The *ald* gene of both *C. beijerinckii* strain NRRL B592 and strain NRRL B593 encodes a polypeptide of 468 amino acids, with a predicted mol. wt. of 51,312 (strain NRRL B592) or 51,353 (strain NRRL B593). A probe derived from the *C. beijerinckii ald* gene hybridized to restriction fragments of the genomic DNA of all tested strains of *C. beijerinckii*, *C. saccharobutylicum*, and *C. saccharoperbutylacetonicum* but not of *C. acetobutylicum* (Toth et al. 1999). The *ald* gene is part of the solvent production operon of *C. beijerinckii* (see the section [“Genes and Operons for Solvent Production and the Genome of Solvent-Producing Bacteria”](#) in this chapter).

Cloning and sequencing of the solvent-production genes of *C. acetobutylicum* strains ATCC 824 and DSM 792 led to the discovery of the *aad/adhE* gene (CAP0162) in the solvent-production operon (Fischer et al. 1993; Nair et al. 1994). The *aad/adhE* gene is located on the naturally occurring plasmid pSOL1 (see the section [“Genes and Operons for Solvent Production and the Genome of Solvent-Producing Bacteria”](#) in this chapter for the genome structure) and encodes a polypeptide of 862 amino acids (predicted MW 95.2 kDa). The *aad/adhE*-encoded polypeptide is related to the AdhE protein of *E. coli* (see “Ethanol” in Organic Acid and Solvent Production, Part II in this volume) and was therefore proposed as a fused aldehyde-alcohol dehydrogenase (Fischer et al. 1993; Nair et al. 1994), with residue 400 roughly the end of the aldehyde dehydrogenase domain and residue 450 roughly the start of the alcohol dehydrogenase domain. The Aad protein of *C. acetobutylicum* ATCC 824 has been purified to homogeneity (Ismail and Chen 1998), and it has a native MW of 1.5 MDa or above and an observed subunit MW of 97.4 kDa. With NADH as a coenzyme, the purified Aad protein has a 400 times higher aldehyde dehydrogenase activity (with butyryl-CoA) than alcohol dehydrogenase activity (with butyraldehyde) on the basis of the catalytic efficiency or the V_{max}/K_m value (A. I. Ismail and J.-S. Chen, unpublished data). A DNA probe encompassing amino acid residues 278–556 of the *aad*-encoded polypeptide hybridized to restriction fragments of *C. acetobutylicum* genomic DNA but not to those of three other solvent-producing species of clostridia, suggesting that the Aad/AdhE protein is a source of ALDH activity in *C. acetobutylicum* (Toth et al. 1999).

Clostridium acetobutylicum ATCC 824 contains a second *adhE*-like gene (*adhE2*; CAP0035) on the pSOL1 plasmid, and

the *adhE2* gene encodes a polypeptide of 858 amino acids (MW 94.4 kDa), which has a 66.1 % identity with the AdhE of *C. acetobutylicum* ATCC 824 (Fontaine et al. 2002). The *adhE2*-encoded protein (AdhE2) is a NADH-dependent aldehyde-alcohol dehydrogenase responsible for butanol production under the alcohologenic condition (see the section ● “Physiology of Solvent Production” in this chapter). The AdhE2 protein has been fused with *Strep*-tag II, overexpressed in *E. coli*, and purified (Fontaine et al. 2002). Like the purified AdhE, the purified *Strep*-tag II-AdhE2 protein also exhibited higher NADH-dependent butyraldehyde dehydrogenase (0.74 units/mg) than NADH-dependent butanol dehydrogenase (0.18 units/mg) activities.

Alcohol Dehydrogenase

Alcohol dehydrogenase (ADH; enzymes 15, 18, and 20 in ● Fig. 2.1) is a ubiquitous enzyme, and multiple forms of ADHs, with different molecular structures and physiological roles, are usually found in an organism. Although most ADHs accommodate substrates with different carbon-chain lengths, they generally display a specificity for either primary alcohols (and aldehydes) or secondary alcohols (and ketones), and they show a higher catalytic efficiency (based on the ratio $[k_{cat}]/K_m$) with NAD, NADH, NADP, or NADPH as the coenzyme. For the production of butanol, isopropanol, and ethanol by the solvent-producing clostridia, ADH catalyzes the final reaction of the respective pathways, and the presence of multiple ADHs may be expected.

The multiplicity of ADH and the relatedness of the ADHs in the solvent-producing clostridia have been reviewed (Chen 1995). Besides the different primary ADHs, a novel primary-secondary ADH has been purified from two strains of *C. beijerinckii* that produce both butanol and isopropanol (Ismail et al. 1993). The primary-secondary ADH of *C. beijerinckii* NRRL B593 is a tetramer of identical subunits (351 amino acids), NADPH-dependent, and equally active in reducing aldehydes and ketones to, respectively, primary and secondary alcohols. Therefore, the primary-secondary ADH is sufficient for the production of both butanol and isopropanol. The gene for the primary-secondary ADH of *C. beijerinckii* NRRL B593 has been cloned and sequenced (Peretz et al. 1997), and the X-ray crystallographic structure of the ADH has been solved (Korkhin et al. 1998).

The solvent-producing clostridia have both NADH-dependent and NADPH-dependent primary ADHs (Dürre et al. 1987; Hiu et al. 1987; Youngleson et al. 1988; Welch 1991; Yan 1991). Although NADPH-dependent primary ADHs have been separated from NADH-dependent primary ADHs (Welch 1991; Yan 1991), only the NADH-dependent primary ADHs have been purified from *C. acetobutylicum* ATCC 824 and *C. beijerinckii* NRRL B592. From *C. acetobutylicum* ATCC 824, four enzymes with primary ADH activities have been purified: the butanol dehydrogenases I and II (BDH I and BDH II), with a native MW slightly higher than 80 kDa and a subunit MW of 42 kDa (Welch et al. 1989; Petersen et al. 1991), and the much

larger aldehyde-alcohol dehydrogenases (Aad or AdhE and AdhE2; see the section ● “Aldehyde Dehydrogenase” for properties of Aad/AdhE and AdhE2 in this chapter).

BDH I and BDH II of *C. acetobutylicum* ATCC824 are encoded, respectively, by *bdhA* (CAC3299) and *bdhB* (CAC3298), which are contiguous genes but are transcribed separately (Petersen et al. 1991; Walter et al. 1992). It should be noted that, on the basis of the N-terminal amino acid sequence, the BDH I (NH₂-Met-Leu-Ser-Phe-) described in Walter et al. (1992) and in the annotation of the *C. acetobutylicum* genome sequence was designated “BDH II” (which binds to Blue Sepharose) by Welch (1991). The *bdhA* and *bdhB* genes code for polypeptides of 389 (MW 43,039) and 390 (MW 43,227) amino acid residues, respectively (Walter et al. 1992). The amino acid sequences of BDH I and BDH II have a 72.9 % positional identity. BDH II of Welch (Welch et al. 1989; Welch 1991) has a 46-fold greater activity with butyraldehyde than acetaldehyde, whereas BDH I (which does not bind to Blue Sepharose) has only a twofold greater activity with the C₄ substrate than with the C₂ substrate.

Clostridium beijerinckii NRRL B592, a strain not producing isopropanol, has three NADH-dependent primary ADHs (Chen 1995). These three ADHs, designated “ADH-1,” “ADH-2,” and “ADH-3,” are homo- and heterodimers of subunits encoded by the *adhA* gene (388 amino acids; MW 42,617; J. Toth, A. Ismaiel, and J.-S. Chen, GenBank accession number [[{http://www.ncbi.nlm.nih.gov/entrez/query.fcgi?cmd=Search%26db=Nucleotide%26term=AF497741%26doptcmdl=DocSum}](http://www.ncbi.nlm.nih.gov/entrez/query.fcgi?cmd=Search%26db=Nucleotide%26term=AF497741%26doptcmdl=DocSum)] {AF497741}) and the *adhB* gene (388 amino acids; MW 42,715; J. Toth and J.-S. Chen, GenBank accession number [[{http://www.ncbi.nlm.nih.gov/entrez/query.fcgi?cmd=Search%26db=Nucleotide%26term=AF497742%26doptcmdl=DocSum}](http://www.ncbi.nlm.nih.gov/entrez/query.fcgi?cmd=Search%26db=Nucleotide%26term=AF497742%26doptcmdl=DocSum)] {AF497742}). The *adhA*- and *adhB*-encoded polypeptides differ by only 13 amino acids (3 %), and except for the C-terminal 40 residues, the *C. beijerinckii* AdhA and AdhB sequences are highly similar to that of Adh-1 of *C. saccharobutylicum* NCP 262 (J. Toth et al., unpublished data). The *adhA* and *adhB* genes of *C. beijerinckii* NRRL B592 are not contiguous, and they have unrelated flanking sequences. Thus, although the NADH-dependent primary ADHs of the solvent-producing clostridia are structurally related (Chen 1995), their positions in the respective genomes are different.

Acetoacetate: Acetate/Butyrate CoA-transferase

The enzyme (16 in ● Fig. 2.1) catalyzes the reversible transfer of the CoA moiety between an acyl-CoA and a carboxylic acid. The physiological reaction of the CoA-transferase, which is synthesized when cells enter the solventogenic phase, is to convert acetoacetyl-CoA into acetoacetate, with acetate or butyrate as the CoA-acceptor. Therefore, the activity of the CoA-transferase results in the reutilization of preformed acetate and butyrate, and the CoA-derivatives of the two acids enter the acid- or solvent-producing pathways. When butyrate is the CoA-acceptor, reaction 16 leads to the production of one acetone

(or isopropanol) and one butanol or butyrate. When acetate is the CoA-acceptor, the resulting acetyl-CoA will enter the solventogenic or butyrate-forming pathway through the condensation reaction catalyzed by thiolase (enzyme 4 in [Fig. 2.1](#)), and the acetoacetyl-CoA so produced can be used for the production of either acetone/isopropanol (via CoA-transferase) or butanol/butyrate (via 3-hydroxybutyryl-CoA dehydrogenase).

CoA-transferase has been purified from *C. acetobutylicum* ATCC 824 (Wiesenborn et al. 1989a) and *C. beijerinckii* NRRL B593 (Colby 1993). During purification, the CoA-transferase of these two species requires high concentrations of ammonium sulfate (0.5–0.75 M) and glycerol (15–20 %, vol/vol) at pH 7 to preserve activity. The CoA-transferase of *C. acetobutylicum* ATCC 824 has unusually high K_m values for acetate (1.2 M) and butyrate (0.66 M), whereas the enzyme from *C. beijerinckii* NRRL B593 has K_m values of 0.5 M for acetate and 10 mM for butyrate. The K_m values for acetoacetyl-CoA range between 21 and 56 μ M with acetate or butyrate as the cosubstrate for the CoA-transferases from both species (Chen 1993).

The CoA-transferase of *C. acetobutylicum* and *C. beijerinckii* has a native MW of 85–93 kDa and appears to be a tetramer composed of two types of subunits. The structural genes (*ctfA* and *ctfB*) for the subunits of CoA-transferase have been cloned from *C. acetobutylicum* strains ATCC 824 (Petersen et al. 1993) and DSM 792 (Fischer et al. 1993) and from *C. beijerinckii* strains NRRL B592 (Hong 1999) and NRRL B593 (J. Toth et al., GenBank accession number [[{AF157306}](http://www.ncbi.nlm.nih.gov/entrez/query.fcgi?cmd=Search%26db=Nucleotide%26term=AF157306%26doptcmdl=DocSum)]). The *ctfA* and *ctfB* genes are conserved in the two species, and they are flanked by similar solvent-production genes in the two species. However, the actual flanking gene or the orientation of the flanking gene differs in the two species (see the section [“Genes and Operons for Solvent Production and the Genome of Solvent-Producing Bacteria”](#) in this chapter). The *C. acetobutylicum* ATCC 824 *ctfA* gene (CAP 0163) encodes a polypeptide of 218 amino acids (MW 23,643), and the *ctfB* gene (CAP 0164) encodes a polypeptide of 221 amino acids (MW 23,626). The *ctfA* and *ctfB* genes of *C. beijerinckii* strain NRRL B593 encode polypeptides of, respectively, 217 amino acids (MW 23,231) and 221 amino acids (MW 23,710). The *ctfA* and *ctfB* genes of *C. beijerinckii* strains NRRL B592 are very similar to the respective genes of *C. beijerinckii* strain NRRL B593 (Hong 1999).

Acetoacetate Decarboxylase

Acetoacetate decarboxylase (AADC; enzyme 17 in [Fig. 2.1](#)) catalyzes the irreversible conversion of acetoacetate to acetone and CO₂. AADC is thus a crucial enzyme for solvent production because of its consumption of acetoacetate to allow the CoA-transferase to continue to channel preformed butyrate and acetate into solvent production. AADC of *C. acetobutylicum*

strains BY (the Weizmann strain) and NRRL B528 is a stable protein and has been extensively studied, and the literature has been briefly reviewed (Chen 1993).

AADC of *C. acetobutylicum* is an oligomeric protein (native MW about 300–330 kDa; Hamilton and Westheimer 1959; Gerischer and Dü 1990). Its structural gene (*adc*; CAP 0165) encodes a polypeptide of 244 amino acids (calculated MW 27,519; Gerischer and Dü 1990; Petersen et al. 1993). The *adc* gene of *C. beijerinckii* strains NRRL B592 and NRRL B593 encodes a polypeptide of 246 amino acids (calculated MWs 27,392 and 27,353, respectively) for the two strains (Hong 1999; J. Toth and J.-S. Chen, GenBank accession number [[{AF157305}](http://www.ncbi.nlm.nih.gov/entrez/query.fcgi?cmd=Search%26db=Nucleotide%26term=AF157305%26doptcmdl=DocSum)]).

Phosphotransbutyrylase and Butyrate Kinase

Phosphotransbutyrylase (PTB; enzyme 8 in [Fig. 2.1](#)) catalyzes the conversion between butyryl-CoA and butyryl phosphate, whereas butyrate kinase (BK; enzyme 9 in [Fig. 2.1](#)) catalyzes the conversion between butyryl phosphate and butyrate and ATP (Chen 1993). PTB and BK are thus key enzymes for the formation of butyric acid. Theoretically, PTB and BK can catalyze the ATP-dependent reutilization of preformed butyrate for solvent production (Husemann and Papoutsakis 1989), but direct evidence for any significant role played by PTB and BK in this respect is still lacking.

PTB has been purified from *C. acetobutylicum* ATCC 824 (Wiesenborn et al. 1989b) and *C. beijerinckii* NRRL B593 (Thompson and Chen 1990), and the two purified PTBs are similar in native MW (264 vs. 205 kDa), subunit MW (31 vs. 33 kDa), and in the K_m for butyryl-CoA (0.11 vs. 0.04 mM) and phosphate (14 vs. 6.5 mM). The PTB of *C. beijerinckii* NRRL B593 also reacts with acetoacetyl-CoA (with a K_m of 1.1 mM) in the presence of phosphate, and coenzyme A-SH (CoASH) is a product of the reaction (Thompson and Chen 1990).

PTB is encoded by the *ptb* gene. The *ptb* gene of *C. acetobutylicum* ATCC 824 (CAC 3076) encodes a polypeptide of 296 amino acids (calculated MW 31,546; Walter et al. 1993), whereas the *ptb* gene of *C. beijerinckii* NCIMB 8052 encodes a polypeptide of 302 amino acids (calculated MW 32,445; Oultram et al. 1993). PTB appears to be a hexamer or an octamer of identical subunits. The *ptb* gene follows a *buk* gene (for BK) to form an operon in these two organisms. In *C. acetobutylicum* ATCC 824, a second *buk* gene (CAC 1860) is present (Huang et al. 2000); the gene is expressed, but its physiological significance is unknown.

Both butyrate kinases of *C. acetobutylicum* ATCC 824 have been purified. The first butyrate kinase (BK-I) was purified from *C. acetobutylicum* ATCC 824 (Hartmanis 1987), whereas the second was purified from a recombinant *E. coli* expressing BK-II (Huang et al. 2000). The kinetic properties of BK-I (native MW 85 kDa) were measured in the acyl phosphate-forming

or reverse direction. The *buk* gene for BK-I (CAC 3075) of *C. acetobutylicum* ATCC 824 encodes a polypeptide of 355 amino acids (calculated MW 39,002; Walter et al. 1993). The *buk* gene of *C. beijerinckii* NCIMB 8052 also encodes a polypeptide of 355 amino acids (calculated MW 38,438; Oultram et al. 1993).

It has been speculated that a decrease in the flux of butyryl-CoA going into butyrate formation may favor the production of butanol. Use of the antisense RNA technique to decrease the expression of either the BK or the PTB gene in *C. acetobutylicum* caused a lowering of both PTB and BK activities (but to a different degree), yet it did not have any significant impact on butyrate formation, suggesting that butyrate formation is not controlled by the levels of PTB and BK (Desai and Papoutsakis 1999). However, the antisense RNA against the PTB gene caused an increase in solvent production, whereas the antisense RNA against the BK gene caused a decrease in solvent production, although both caused decreases in PTB and BK activities. A *C. acetobutylicum* mutant (PJC4BK) with the gene for BK inactivated showed superior solvent productivity between pH 5.0 and 5.5 (Harris et al. 2000), whereas it exhibited good solvent productivity at pH greater than or equal to 5.5 (Green et al. 1996). Therefore, a decrease in the BK activity by any of these three manipulations had very different effects on the solvent productivity, which perhaps illustrates the complexity of the mechanisms regulating solvent production.

Phosphotransacetylase and Acetate Kinase

Phosphotransacetylase (PTA; enzyme 10 in [Fig. 2.1](#)) and acetate kinase (AK; enzyme 11 in [Fig. 2.1](#)) catalyze consecutive reactions analogous to those catalyzed, respectively, by phosphotransbutyrylase (PTB) and butyrate kinase (BK). Thus, PTA catalyzes the conversion between acetyl-CoA and acetyl phosphate, and AK catalyzes the conversion between acetyl phosphate and acetate and ATP (Chen 1993). The two enzymes PTA and AK are potentially involved in ATP-dependent reutilization of preformed acetate during solvent production; however, like the situation involving PTB and BK, direct evidence in support of such a role is lacking.

PTA and AK activities have been measured in cell-free extracts of solvent-producing clostridia, and these activities can be separated from those attributable to PTB and BK, respectively (Chen 1993). PTA has only been partially purified from *C. beijerinckii* (Chen 1993), whereas AK has been purified from *C. acetobutylicum* DSM 1731 (Winzer et al. 1997). AK of *C. acetobutylicum* DSM 1731 has a native MW of 87–94 kDa and a measured subunit MW of 43 kDa. The K_m values for acetyl phosphate, Mg-ADP, acetate, and Mg-ATP are, respectively, 0.58, 0.71, 73, and 0.37 mM. Results of northern blot analysis show that there is no significant difference in the transcription of the acetate kinase gene (*ack*) in cells of *C. acetobutylicum* DSM 1731 under acid- and solvent-producing conditions (Winzer et al. 1997).

The *C. acetobutylicum* ATCC824 genes for PTA (*pta*; CAC 1742) and AK (*ack*; CAC 1743) have been cloned and sequenced, and the *pta* gene precedes the *ack* gene in forming an operon (Boynton et al. 1996b). The *pta* gene encodes a polypeptide of 333 amino acids (calculated MW 36.2 kDa), whereas the *ack* gene encodes a polypeptide of 401 amino acids (calculated MW 44.3 kDa).

Genes and Operons for Solvent Production and the Genome of Solvent-Producing Bacteria

As shown in [Fig. 2.1](#), the enzymes catalyzing reactions 16–18 (between acetoacetyl-CoA and acetone or isopropanol) and the enzymes catalyzing reactions 14 and 15 (between butyryl-CoA and butanol) are specifically required for solvent production. The genes encoding these enzymes (*ctfA* and *ctfB* for acetoacetate:butyrate/acetate CoA-transferase, *adc* for acetoacetate decarboxylase, and *ald* or *aad/adhE* for aldehyde and alcohol dehydrogenase) form monocistronic or polycistronic operons. All characterized strains of solvent-producing clostridia have a gene cluster, which contains the acetone-forming genes and most of the butanol-forming genes.

In *C. acetobutylicum* strains ATCC 824 and DSM 792, the main gene cluster for solvent production consists of two converging operons (Dürre et al. 2002) of the following organization (arrowheads indicating the direction of translation)

aad/adhE ►-R *ctfA* ►-R *ctfB* ►-R ◀-I *adc*

The solvent-production or “*sol*” operon contains the *aad/adhE* and the *ctf* genes, whereas the *adc* operon is monocistronic. The *aad/adhE* gene and the separately transcribed *adc* operon are characteristics of this species (Hong 1999; Toth et al. 1999). Transcriptional regulation of the solvent-production genes of *C. acetobutylicum* has been reviewed (Dürre et al. 2002), and the Spo0A protein is a significant component of the regulatory networks for solventogenesis (Harris et al. 2002; Thormann et al. 2002).

In *C. beijerinckii* strains NRRL B592 and NRRL B593, the *ald* gene which encodes an aldehyde dehydrogenase precedes the *ctfA* gene to give a solvent-production operon of the following organization (Hong 1999; Toth et al. 1999; Toth, J. and J.-S. Chen, GenBank accession numbers [<http://www.ncbi.nlm.nih.gov/entrez/query.fcgi?cmd=Search%26db=Nucleotide%26term=AF157305%26doptcmdl=DocSum>] {AF157305}) and [<http://www.ncbi.nlm.nih.gov/entrez/query.fcgi?cmd=Search%26db=Nucleotide%26term=AF157306%26doptcmdl=DocSum>] {AF157306}):

ald ►-R *ctfA* ►-R *ctfB* ►-R *adc* ►-R

Both *C. acetobutylicum* and *C. beijerinckii* have genes located elsewhere for the multiple alcohol dehydrogenases. Whereas the *sol* and *adc* operons of *C. acetobutylicum* are located on the pSOL1 plasmid, the contiguous but monocistronic *bdhA* and *bdhB* genes are located on the chromosome (see section [“Metabolic Pathways and Enzymology of Solvent Production”](#) in this chapter). *Clostridium beijerinckii* NRRL B592 has *adhA* and *adhB* genes, which encode the subunits of

three dimeric isozymes of primary alcohol dehydrogenases, and the *adhA* and *adhB* genes are not contiguous genes (GenBank accession numbers [<http://www.ncbi.nlm.nih.gov/entrez/query.fcgi?cmd=Search%26db=Nucleotide%26term=AF497741%26doptcmdl=DocSum>] {AF497741}] and [<http://www.ncbi.nlm.nih.gov/entrezquery.fcgi?cmd=Search%26db=Nucleotide%26term=AF497742%26doptcmdl=DocSum>] {AF497742}]). The isopropanol-producing *C. beijerinckii* NRRL B593 has an *adh* gene encoding the primary-secondary alcohol dehydrogenase (Peretz et al. 1997). Although the *adhA* gene of *C. beijerinckii* NRRL B592 and the *adh* gene of *C. beijerinckii* NRRL B593 are structurally unrelated, both of them are preceded by an *stc* gene (Peretz et al. 1997; Hong 1999; GenBank accession numbers [<http://www.ncbi.nlm.nih.gov/entrez/query.fcgi?cmd=Search%26db=Nucleotide%26term=AF157307%26doptcmdl=DocSum>] {AF157307}] and [<http://www.ncbi.nlm.nih.gov/entrezquery.fcgi?cmd=Search%26db=Nucleotide%26term=AF497741%26doptcmdl=DocSum>] {AF497741}]), which could encode an enhancer-binding protein belonging to the NtrC family (Osuna et al. 1997), and are followed by a *hydG* gene (Pedroni et al. 1995; Rakhley et al. 1999), which could encode an electron-transfer subunit of a redox enzyme. The conserved location of the *stc* gene relative to the *adh* or *adhA* gene in the two strains of *C. beijerinckii* suggests a regulatory role for the *stc* gene in the expression of the *adh* or *adhA* gene, but this relationship remains to be established.

The enzymes catalyzing reactions 5–7 (between acetoacetyl-CoA and butyryl-CoA) are required for the formation of both butyric acid and butanol (Chen 1993). The five genes encoding these enzymes (*hbd* for 3-hydroxybutyryl-CoA dehydrogenase, *crt* for crotonase, and *bcd* for butyryl-CoA dehydrogenase) and an electron-transfer protein (*etfA* and *etfB*) form the “*bcs*” operon (Boynton et al. 1996a; Toth, J. and J.-S. Chen, GenBank accession number [<http://www.ncbi.nlm.nih.gov/entrez/query.fcgi?cmd=Search%26db=Nucleotide%26term=AF494018%26doptcmdl=DocSum>] {AF494018}]). The genes of the *bcs* operon are conserved in *C. acetobutylicum* and *C. beijerinckii* and have the following organization:

crt ►-R *bcd* ►-R *etfB* ►-R *etfA* ►-R *hbd* ►-R

Because the proteins encoded by these genes are needed for both primary and secondary metabolism, the promoter region of the *bcs* operon must differ from that for the *sol* operon.

In *C. saccharobutylicum* NCP 262, the following arrangement of solvent production-related genes has been described (Youngleson et al. 1995):

etfB ►-R *etfA* ►-R *hbd* ►-R *adh-1* ►-R

The *adh-1* gene encodes an NADPH-linked alcohol dehydrogenase, and its transcription peaks shortly before the onset of solvent production, suggesting the functioning of other *adh* genes later in the growth cycle (Youngleson et al. 1995). The *etfA* and *hbd* genes (the DNA sequence preceding the *etfB* gene has not been reported) are transcribed during both acid- and solvent-producing phases of growth.

Among the alcohol dehydrogenases of the solvent-producing clostridia, the enzymes encoded by the *bdhA* and *bdhB* genes of *C. acetobutylicum* ATCC 824, the *adhA* and

adhB genes of *C. beijerinckii* NRRL B592, and the *adh-1* gene of *C. saccharobutylicum* NCP 262 are related (Walter et al. 1992; Chen 1995; Toth, J. et al., unpublished results; GenBank accession numbers [<http://www.ncbi.nlm.nih.gov/entrez/query.fcgi?cmd=Search%26db=Nucleotide%26term=AF497741%26doptcmdl=DocSum>] {AF497741}] and [<http://www.ncbi.nlm.nih.gov/entrez/query.fcgi?cmd=Search%26db=Nucleotide%26term=AF497742%26doptcmdl=DocSum>] {AF497742}]). The roles of these *adh* genes in butanol formation will need further clarification.

The Genome of *Clostridium acetobutylicum* ATCC824

The genome of *C. acetobutylicum* consists of a chromosome of about 4 Mb and a megaplasmid of about 200 kb (Cornillot and Soucaille 1996; Cornillot et al. 1997a, b). The genome sequence of *C. acetobutylicum* ATCC 824 has been determined (Nölling et al. 2001). The chromosome is 3,940,880 bp in length (GenBank accession number [<http://www.ncbi.nlm.nih.gov/entrez/query.fcgi?cmd=Search%26db=Nucleotide%26term=AE001437%26doptcmdl=DocSum>] {AE001437}]), with a total of 3,740 polypeptide-encoding ORFs and 107 stable RNA genes having been identified and accounting for 88 % of the chromosomal DNA. The average length of the intergenic regions is about 121 bp. The megaplasmid, pSOL1, is 192,000 bp in length (GenBank accession number [<http://www.ncbi.nlm.nih.gov/entrez/query.fcgi?cmd=Search%26db=Nucleotide%26term=AE001438%26doptcmdl=DocSum>] {AE001438}]) and appears to encode 178 polypeptides. There appear to be two unrelated cryptic prophages in the chromosome. The first spans about 90 kb and includes about 85 genes (CAC1113 to CAC1197), whereas the second spans about 60 kb and includes about 79 genes (CAC1878 to CAC1957). Genes for three distinct insertion sequence-related proteins are present on the chromosome, but only one of these is intact. It is believed that no active insertion sequence elements are present in the *C. acetobutylicum* genome.

Four genes (*aad/adhE*, *ctfA*, *ctfB*, and *adc*; CAP0162 to CAP0165), which are required for butanol and acetone production under acidic growth conditions, occur as two converging operons on the pSOL1 plasmid. The pSOL1 plasmid also contains the second copy of the aldehyde-alcohol dehydrogenase gene (*adhE2*; CAP0035), which is required for butanol production under the neutral or alcohologenic growth conditions (Fontaine et al. 2002). In addition, the pSOL1 plasmid contains genes for a pyruvate decarboxylase (CAP0025) and an alcohol dehydrogenase (CAP0059), whose physiological roles have not been determined. The genes for two characterized alcohol dehydrogenases (CAC3298 and CAC3299) are present on the chromosome, and one or both of them may function during butanol production (Dürre et al. 2002).

On the basis of the genome sequence, the number of recognizable sporulation genes is smaller in *C. acetobutylicum* than in *Bacillus subtilis*. Some of the Spo0 and SpoV genes have not been detected in *C. acetobutylicum*, but the gene encoding an apparent ortholog of the Spo0A protein (CAC2071) has been identified. The number of identified genes for spore-coat biosynthesis, spore germination, and septum formation is also

smaller in *C. acetobutylicum* than in *B. subtilis* (Nölling et al. 2001), but it is not known how much of the difference can be attributed to mechanistic differences in the sporulation-germination processes between the two organisms.

A large number of genes, some of which are organized in apparent operons, have been identified for substrate utilization and transport, and they occur on both the chromosome and the megaplasmid (Nölling et al. 2001). For example, putative genes for cellulose degradation are found on the chromosome (CAC0910–CAC0919, CAC0561, and CAC3469), whereas putative genes for xylan degradation are found on both the chromosome (CAC0617 and CAC0706) and the megaplasmid (CAP0071, CAP0114, CAP0115, and CAP0117–CAP0120). Knowledge of genes for substrate utilization and their regulation could be useful in attempts to expand the substrate range of *C. acetobutylicum* or other solvent-producing species.

The Genome of *C. beijerinckii* NCIMB 8052

Clostridium beijerinckii NCIMB 8052 has a circular, 6.7-Mb chromosome (Wilkinson and Young 1995). A combined physical and genetic map shows that the genes for acetoacetate decarboxylase (*adc*) and CoA-transferase (*ctfA* and *ctfB*) are located at some distance from either an alcohol dehydrogenase gene (*bdh*) or the genes for butyrate kinase (*buk*) and phosphotransbutyrylase (*ptb*). The “*deg*” gene, whose integrity is related to the strain’s tendency to lose solvent productivity (degeneration), was later identified as the *fms* gene encoding the peptide deformylase (Evans et al. 1998).

The Genome of *C. saccharobutylicum* NCP 262

Clostridium saccharobutylicum NCP 262 has a circular, 5.3-Mb chromosome (Keis et al. 2001b). The positions of genes required for the formation of butyric acid as well as of two genes for alcohol dehydrogenases have been located on the map. The position of the genes for acetone formation (*ctfA*, *ctfB*, and *adc*) has not been reported.

Tools for the Genetic Manipulation of Solvent-Producing Clostridia

Since the 1980s, much progress has been made in the development of tools for the genetic manipulation of solvent-producing clostridia (Young et al. 1989; Mitchell 1998). The basic tools are now available for carrying out a variety of genetic and molecular biological experiments with the solvent-producing clostridia.

Mutagenesis experiments with solvent-producing clostridia have been performed in a number of laboratories. Irradiation with ultraviolet (UV) light is not effective (Bowring and Morris 1985), whereas several alkylating agents have been used successfully (Allcock et al. 1981; Bowring and Morris 1985; Hermann et al. 1985; Lemmel 1985; Junelles et al. 1987; Rogers and Palosaari 1987; Clark et al. 1989; Cueto and Mendez 1990; Annous and Blaschek 1991; Gutierrez and Maddox 1992).

Mutagenesis with transposons has been used with good results (Woolley et al. 1989; Bertram et al. 1990; Babb et al. 1993; Sass et al. 1993; Mattsson and Rogers 1994; Kashket and Cao 1995). Homologous recombination for directed mutagenesis has been demonstrated in *C. acetobutylicum* (Green and Bennett 1996) and in *C. beijerinckii* (Wilkinson and Young 1994) using nonreplicative plasmids and in *C. acetobutylicum* using a replicative plasmid (Harris et al. 2002). The antisense RNA technique (Desai and Papoutsakis 1999) provides a strategy for altering the phenotype without modifying the targeted gene itself.

A dominant selective marker is an essential element of a gene-transfer system. The erythromycin resistance gene of the streptococcal plasmid pAM β 1 has been widely used (Young et al. 1989). When selection for erythromycin resistance needs to be performed under acidic culture conditions over an extended period of time, the more acid-stable clarithromycin is used in place of erythromycin (Mermelstein and Papoutsakis 1993a). The *Bacillus* plasmid pIM13 has provided the replicon for several shuttle vectors that can be maintained in *E. coli* and *C. acetobutylicum* (Lee et al. 1992), *C. beijerinckii* (Li 1998), *C. saccharobutylicum* (Azeddoug et al. 1992) and *C. saccharoperbutylacetonicum* (Truffaut et al. 1989). Plasmids isolated from clostridia also provided replicons for the construction of shuttle vectors (Yoshino et al. 1990; Yoon et al. 1991; Lee et al. 1992). *Clostridium acetobutylicum* ATCC 824 contains a restriction endonuclease *Cac824I* whose recognition sequence 5'-GCNGC occurs frequently in *E. coli* plasmids. To protect the *E. coli*-*Clostridium* shuttle vector from restriction by *Cac824I*, in vivo methylation of the plasmid in *E. coli* by the *Bacillus subtilis* phage ϕ 3 T I methyltransferase has been successfully used (Mermelstein and Papoutsakis 1993b).

Different methods, including conjugative and protoplast-mediated transfers, have been developed for the introduction of vectors carrying specific genes into the solvent-producing clostridia (Mitchell 1998). Much effort was put into the development of conjugative transfer systems (Oultram and Young 1985; Reyssset and Sebald 1985; Yu and Pearce 1986; Oultram et al. 1987; Bertram and Dü 1989; Woolley et al. 1989; Williams et al. 1990) and the protoplast-mediated transfers (Reid et al. 1983; Lin and Blaschek 1984; Jones et al. 1985). However, it is the electroporation technique that has made it easier to transform different strains of solvent-producing clostridia. Conditions of electroporation for the following strains are available: *C. acetobutylicum* ATCC 824 (Mermelstein et al. 1992), *C. acetobutylicum* DSM 792 (Nakotte et al. 1998), *C. beijerinckii* NCIMB 8052 (Oultram et al. 1988), *C. beijerinckii* NRRL B592 (Birrer et al. 1994; Li 1998), and *C. beijerinckii* NRRL B593 (Li 1998).

A good reporter gene is required for the study of promoters. The commonly used reporter systems, such as the *E. coli* β -galactosidase or the green fluorescent protein (GFP), are not suitable for the solvent-producing clostridia because of the biased codon usage pattern (AT-rich), an acidic environment, and the absence of molecular oxygen (O₂) in the clostridia. A β -galactosidase encoded by

the *lacZ* gene of *Thermoanaerobacterium thermosulfurogenes* EM1 has been used as a reporter in *C. acetobutylicum* ATCC 824 (Tummala et al. 1999). However, a β -galactosidase is present in *C. acetobutylicum* NCIMB 2951 (Hancock et al. 1991). The use of β -galactosidase as a reporter in the solvent-producing clostridia may be limited if other strains also contain this enzyme. The *gusA*-encoded β -glucuronidase activity was successfully used as a reporter in *C. beijerinckii* NCIMB 8052 (Ravagnani et al. 2000). The secondary alcohol dehydrogenase activity (reduction of acetone to isopropanol) of the primary-secondary ADH of *C. beijerinckii* NRRL B593 has been used as a reporter in non-isopropanol-producing strains, such as *C. acetobutylicum* ATCC 824 and *C. beijerinckii* NRRL B592 (Li 1998). Further development of efficient reporter systems for the solvent-producing clostridia should facilitate the characterization of the promoters for solvent-production operons.

Commercial Applications

Commercial Production

Acetone, butanol, and isopropanol are now produced by synthetic processes using petrochemicals as the starting material. However, the fermentation process is in operation in China (Jones and Keis 1995; R.-X. Shen, personal communication). Use of the fermentation process in other countries has been reported (Billig 1992), but the scale of the operation and other details have not. In Austria, *C. beijerinckii* NRRL B592 is being tested on the pilot-plant scale (50 l for the first stage and approximately 150 l for the second stage) to convert low-grade potatoes into acetone and butanol, and on a demonstration scale, tests are planned (Gapes 2000b). Commercial production of acetone, butanol, and isopropanol is briefly described below.

Acetone

Most of the world's acetone is now obtained as a coproduct of phenol production by the cumene process. In the cumene-to-phenol process, benzene is alkylated to cumene, which is oxidized to cumene hydroperoxide, and the latter is cleaved to acetone and phenol. Dehydrogenation of isopropanol accounts for most of the acetone that is produced to meet the demand in excess of that supplied by the phenol process. The economics of acetone production are unusual in that the supply depends on the production of phenol, whereas the demand is controlled by the uses of acetone. When the consumption of acetone grows at a slower rate than the growth of demand for phenol, an excess in the supply of acetone occurs. More than 75 % of the world's and about 95 % of the United States' acetone production now comes from the cumene-to-phenol process. World production of acetone in 1990 was about three million metric t per year, of which about one-third was made in the United States. It has been predicted that acetone as a coproduct from the cumene-to-phenol process will continue to dominate supply, and production of "on-purpose" acetone will probably decline as

supplies of by-product acetone increase (Howard 1991), which effectively eliminates the need to use a fermentation process to produce acetone, except where the local economic situations may favor the fermentation process.

Butanol

The principal commercial source of *n*-butanol is through hydrogenation of *n*-butyraldehyde, which is obtained from the Oxo reaction of propylene. The Oxo process produces *n*-butyraldehyde and isobutyraldehyde. The mixture may be separated before hydrogenation of *n*-butyraldehyde to *n*-butanol, or the mixture is hydrogenated and the products, *n*-butanol and isobutanol, are separated afterward (Billig 1992). As of January 1, 1990, the total United States capacity to produce *n*-butanol (591,000 t or 1,182 million lbs per year) was roughly equal to the combined capacity of Western Europe and Southeast Asia (Billig 1992). Between 1985 and 1995, the United States production of *n*-butanol increased from 716 to 1,493 million lbs (Anonymous 1996b).

Isopropanol

Isopropanol is generally known as the first petrochemical (Logsdon and Loke 1999). It is manufactured from propylene by either an indirect hydration process (the sulfuric acid process) or direct hydration. Isopropanol is also produced by the hydrogenation of acetone, which is a coproduct of the cumene-to-phenol process (Logsdon and Loke 1996). In addition, isopropanol is produced from crude acetone, which is generated as a by-product of propylene oxide manufacture (Anonymous 2001b). Between 1986 and 1996, the United States annual production of isopropanol remained in the range 1,272–1,474 million lbs (Anonymous 1997). The demand for 1999 and 2000 was, respectively, 1,180 and 1,200 million lbs, whereas the production capacity of the United States plants was 1,875 million lbs per year (Anonymous 2001b).

Uses

Acetone

Acetone is an excellent solvent for a wide range of industrial materials including gums, waxes, resins, fats, greases, oils, dyestuffs, and cellulose. Thus, solvent applications remain the largest uses for acetone worldwide, where both acetone and chemicals derived from acetone (the aldol chemicals) are used as solvents. However, because acetone is classified as a volatile organic compound, little or no growth in the solvents market is expected, although acetone is a normal constituent of the environment and is readily biodegradable (Howard 1991).

Acetone is used as a carrier for acetylene, in the manufacturing of a variety of coatings and plastics, and as a raw material for the synthesis of a wide range of products including ketene, methyl methacrylate, and bisphenol A. Following solvent applications, the second largest use for acetone is for the manufacturing of acetone cyanohydrin, which is converted to methacrylates, and this use for acetone has been growing

steadily. However, the fastest growing outlet for acetone is for the manufacturing of bisphenol A, which is used in the manufacturing of polycarbonate. It is interesting to note that although a mole of acetone is consumed in the production of a mole of bisphenol A, the process actually causes the net production of a mole of acetone because 2 moles of acetone are formed for every 2 moles of phenol formed (Howard 1991).

Acetone is potentially useful in blends with gasoline as it can increase the oxygen content, the octane rating, and the water tolerance of the fuel (Bolt 1980; Noon 1982). Acetone can also be blended with butanol, ethanol, and water to serve as an automobile fuel (see the next section **Butanol** in this chapter).

Butanol

n-Butanol is used as a direct solvent in paints and other surface coatings. Other direct solvent applications are in the formulation of pharmaceuticals, waxes, and resins. Additional commercial markets for *n*-butanol include plasticizer esters; butylated melamine-formaldehyde resins; and mono-, di-, and tributylamines. Butyl acetate is one of the more important derivatives of *n*-butanol and is employed as a solvent in rapid drying paints and coatings. *n*-Butanol and butyl acetate act synergistically to serve as a latent solvent system for nitrocellulose lacquers and thinners to give a solvent system stronger than either solvent alone.

Butyl glycol ethers such as 2-butoxyethanol are the largest-volume derivatives of *n*-butanol used in solvent applications. They are used in vinyl and acrylic paints, lacquers, varnishes, and aqueous cleaners to solubilize organic surfactants.

The largest-volume commercial derivatives of *n*-butanol, however, are *n*-butyl acrylate and methacrylate. These are used principally in emulsion polymers for latex paints, in textile applications, and in impact modifiers for polyvinyl chloride (Billig 1992).

n-Butanol has been proposed as a blending agent with gasoline for the internal combustion engines (Noon 1982; Bata et al. 1991; Ladisch 1991) and with diesel (Ladisch 1991). Besides being a component in the alcohol-gasoline blends, *n*-butanol can be blended with acetone, ethanol, and water in a ratio of 51:25:6:18 (by weight) and the blend performed well in a spark-ignited, internal combustion engine (Noon 1982).

n-Butanol can increase the water tolerance of gasoline-ethanol blends (Bolt 1980; Noon 1982). The water tolerance of the gasoline-ethanol blends increases with the ethanol concentration and temperature. At room temperature, a 25 % ethanol blend with gasoline can tolerate about 1 % of water. If 2 % of water is present in the blend, most of the ethanol will separate from gasoline in a few seconds and settle to the bottom, which is known as phase separation. Phase separation renders the ethanol-gasoline blend unfit as an automobile fuel (Bolt 1980). Addition of butanol to the blend increases the water tolerance to prevent phase separation (Bolt 1980; Noon 1982).

Isopropanol

Isopropanol is used as chemical intermediates, solvents, and a component of many medical products. Estimated United States

uses in 1993 were as chemical intermediates, 34 %; personal care and household products, 24 %; coating and ink solvent, 15 %; processing solvent, 12 %; pharmaceuticals, 10 %; and miscellaneous uses, 5 % (Logsdon and Loke 1996). A more recent report (Anonymous 2001b) gave the following breakdown: direct solvent uses, 46 %; chemical derivatives, 36 %; household and personal care products, 12 %; pharmaceuticals, 4 %; and acetone, 2 %.

Isopropanol is used in the production of other chemicals such as derivative ketones, isopropylamines, and isopropyl esters. The use of isopropanol in the production of monoisopropylamine for herbicides (primarily glyphosate) continues to be the fastest growing segment (Anonymous 2001b). A minor use for isopropanol is to serve as a feedstock for the production of acetone to meet the demand in excess of the coproduct acetone from phenol production. However, isopropanol is also produced from crude acetone, which is generated as a by-product of propylene oxide manufacture (Anonymous 2001b).

Because of its balance between alcohol, water, and hydrocarbon-like characteristics, isopropanol is an excellent, low-cost solvent free from government regulations and taxes that apply to ethanol. The lower toxicity of isopropanol favors its use over methanol. Consequently, isopropanol is used as a solvent in many consumer products and industrial products. It is used widely as a solvent for cosmetics, and many aerosol products contain isopropanol as a solvent. Because it is a good solvent for a variety of oils, gums, waxes, resins, and alkaloids, isopropanol is used for preparing cements, primers, varnishes, paints, and printing inks (Logsdon and Loke 1996).

Isopropanol is used as an antiseptic and disinfectant for home, hospital, and industry. Rubbing alcohol, an aqueous solution of 70 % (vol/vol) isopropanol, exemplifies the use of isopropanol in healthcare products. Other examples include 30 % (vol/vol) isopropanol solutions for medicinal liniments, tinctures of green soap, scalp tonics, and tincture of mercuriophen. It is also contained in pharmaceuticals such as local anesthetics, tinctures of iodine, and bathing solutions for surgical sutures and dressings. Over 200 medical uses of isopropanol have been tabulated (Logsdon and Loke 1996).

The use of diisopropyl ether as a fuel additive may become a significant outlet for isopropanol (Logsdon and Loke 1996). Isopropanol itself is a useful blending component for gasoline because of its heating value, oxygen content, and octane rating (Wagner et al. 1980; Schoutens and Groot 1985; Owen and Coley 1990; Houben 1995).

Areas of Research and Development

Microbiology of Solvent Production

The patents issued between the 1910s and 1940s contained many names of solvent-producing bacteria. Studies of industrial strains that are available from culture collections identified four species of *Clostridium* (Johnson et al. 1997; Keis et al. 2001a). Among these four species, *C. beijerinckii* is represented by many characterized strains, whereas the other three have few available strains.

Considering the success of earlier investigators in isolating solvent-producing bacteria from nature, it is reasonable to expect that more solvent-producing organisms are yet to be isolated. There are new efforts in this area, such as the isolation of new solvent-producing clostridia from Columbian soil (Montoya et al. 2001). The new microbiological study may help provide novel solvent-producing organisms, from which more genetic determinants and phenotypic traits may be evaluated for the further development of industrial solvent fermentation.

Enzymology, Genetics, and Regulation of Solvent Production

Efforts to define the enzymology of solvent production by the clostridia continue. Although the enzymes for most of the solvent-forming reactions have been purified from at least one strain of clostridia and characterized, the specific roles of the multiple aldehyde and alcohol dehydrogenases (Chen 1993; 1995) are yet to be defined. The enzyme butyryl-CoA dehydrogenase also has not been characterized. Therefore, the enzymology for the three consecutive reactions leading to the formation of butanol is a subject of research. The characterization of the second aldehyde-alcohol dehydrogenase (AdhE2) from *C. acetobutylicum* ATCC 824 (Fontaine et al. 2002) and the cloning of the two genes (*adhA* and *adhB*) encoding the three primary ADH isozymes of *C. beijerinckii* NRRL B592 (GenBank accession numbers [{"http://www.ncbi.nlm.nih.gov/entrez/query.fcgi?cmd=Search%26db=Nucleotide%26term=AF497741%26doptcmdl=DocSum"}] {AF497741}) and [{"http://www.ncbi.nlm.nih.gov/entrez/query.fcgi?cmd=Search%26db=Nucleotide%26term=AF497742%26doptcmdl=DocSum"}] {AF497742})) represent efforts in this area.

The regulation of the expression of the solvent-production operons is yet to be understood. The promoters for the solvent-production operons and the transcriptional factors for these promoters are the subjects of research. The completion of the genome sequence of *C. acetobutylicum* ATCC 824 and the sequence of the solvent-production operons from different species will facilitate the study of the components of the regulatory circuit. The identification of the Spo0A-binding sequence in the promoter region of solvent-production operons of *C. acetobutylicum* (Thormann et al. 2002) and *C. beijerinckii* (Ravagnani et al. 2000) as well as the role of Spo0A in solvent production by *C. acetobutylicum* (Harris et al. 2002) should accelerate the pace of research in this area. The development of better reporter systems for the study of promoter function in different solvent-producing species will be crucial to progress in this area.

Among the properties of solvent-producing clostridia, strain degeneration can have a serious impact on a commercial operation. Strain degeneration is the result of genetic alterations, but besides a decrease in solvent production, it is accompanied by other phenotypic changes (e.g., change in colony morphology or cell size (Adler and Crow 1987) and Fourier transform infrared [FT-IR] spectra of cells (Schuster et al. 2001)), which may be useful indicators for the early detection of strain degeneration.

It has been observed that a truncated but functional peptide deformylase, which reduces the growth rate of the mutant (Evans et al. 1998), or an elevated acetate concentration in the growth medium (Chen and Blaschek 1999a) will lower the frequency of degeneration of *C. beijerinckii* NCIMB 8052. At present, it is not known how many different classes of genetic changes may result in strain degeneration and how the proportion of degenerated cells in a population may change under different culture conditions. Research in this area will help define the molecular basis for strain degeneration and lead to procedures for the prevention and early detection of degeneration.

Metabolic Engineering

With the genes for the acid- and solvent-forming pathways cloned from *C. acetobutylicum* ATCC 824, it becomes possible to manipulate the metabolic pathways in this and other species for the purpose of improving solvent production. Both gene inactivation and gene overexpression have been used. Nonreplicative integrational plasmids containing internal *buk* or *pta* gene fragments were used to inactivate genes encoding butyrate kinase (*buk*) or phosphotransacetylase (*pta*), respectively (Green et al. 1996). Inactivation of the *buk* gene reduced butyrate kinase activity and increased butanol production (Green et al. 1996; Harris et al. 2000). Interestingly, the onset of solvent production occurred earlier (in the exponential phase of growth) in the BK⁻ mutant (PJC4BK) and the final solvent concentration was significantly higher when the growth pH was lowered from 5.5 to 5.0 (Harris et al. 2000). When anti-*buk*-RNA was used to lower the level of butyrate kinase (Desai and Papoutsakis 1999), the onset of solvent production also occurred earlier than in the control culture. An earlier onset of solvent production allows a longer production period. The levels of butanol, acetone, and ethanol reached 225 mM (16.7 g/l), 76 mM (4.4 g/l), and 57 mM (2.6 g/l), respectively, when the BK⁻ mutant (PJC4BK) was grown at pH 5.0, indicating that the benchmark butanol concentration of 180 mM in the industrial fermentation broth is not due to butanol toxicity.

When a plasmid carrying the *aad* gene (encoding the aldehyde-alcohol dehydrogenase) was introduced into the butyrate kinase mutant (BK⁻) to increase the level of the aldehyde-alcohol dehydrogenase, the resultant strain PJC4BK (pTAAD) produced similar amounts of butanol and acetone as PJC4BK but 98 mM (4.5 g/l) of ethanol. Work with PJC4BK (pTAAD) indicated that the *aad*-encoded aldehyde-alcohol dehydrogenase did not limit butanol production under the fermentation conditions used. The level of ethanol produced by PJC4BK (pTAAD) approached the level (5 g/l) produced by several species of ethanol-producing clostridia (Rogers and Gottschalk 1993).

A synthetic operon (the *ace* operon) for acetone production was constructed by placing the *C. acetobutylicum* *adc*, *ctfA*, and *ctfB* genes (see section 2 “Genes and Operons for Solvent Production and the Genome of Solvent-Producing Bacteria” in this chapter) under the control of the *adc* promoter.

Plasmid pFNK6 carrying the *ace* operon was introduced into *C. acetobutylicum* ATCC 824, and the resultant strain ATCC 824 (pFNK6) had an earlier onset of solvent production at pH 5.5 and 6.5 and produced higher levels of acetone and butanol than the parent strain (Mermelstein et al. 1993). Interestingly, a plasmid-control strain containing a vector without the *ace* operon also produced higher levels of solvents, but levels were lower than that produced by ATCC 824 (pFNK6).

A synthetic operon (the *ace4* operon) composed of four *C. acetobutylicum* ATCC 824 genes (*adc*, *ctfA*, *ctfB*, and *thl*) under the control of the *thl* promoter was constructed to allow *E. coli* to produce acetone (Bermejo et al. 1998). The thiolase gene (*thl*) is included for the conversion of acetyl-CoA to acetoacetyl-CoA (see the section [“Metabolic Pathways and Enzymology of Solvent Production”](#) in this chapter). One of the transformed *E. coli* strains, ATCC 11303 (pACT), produced 125–154 mM of acetone when sodium acetate was added to glucose-fed cultures. Besides their potential usefulness for acetone production, it was suggested that the recombinant strains may be useful hosts for recombinant protein production in that detrimental acetate accumulation can be avoided (Bermejo et al. 1998).

Because isopropanol is potentially a more desirable by-product than acetone for industrial butanol fermentation, a secondary alcohol dehydrogenase can be introduced into acetone- and butanol-producing strains that possess other superior properties, such as a broad substrate range or an early onset of solvent production. The *adh* gene encoding a primary-secondary alcohol dehydrogenase from *C. beijerinckii* NRRL B593 has been successfully expressed in *C. acetobutylicum* ATCC 824 and *C. beijerinckii* NRRL B592 and has enabled the transformants to produce isopropanol (instead of acetone) and butanol as major products (Li 1998). Expression of the *C. beijerinckii* NRRL B593 primary-secondary alcohol dehydrogenase in *E. coli* allows the transformant to produce isopropanol from added acetone (Peretz et al. 1997).

Continuous Solvent Production

A continuous fermentation is superior to a batch process because of more effective uses of the fermentation facility. Since the early 1980s, much effort has been devoted to the characterization of the parameters and the development of a continuous culture system for solvent production (see also patents listed in [Table 2.4](#)). On the basis of the results of these studies, it was concluded that no single growth-limiting factor specifically induces solvent production in a chemostat. In glucose-, nitrogen-, or magnesium-limited chemostats, steady-state solvent production was low or difficult to maintain, and an application of these kinds of limitations to an industrial process seems unlikely (Dürre and Bahl 1996). However, phosphate or sulfate limitation promoted solvent production (Bahl et al. 1982b; Dürre and Bahl 1996).

A two-stage phosphate-limited culture system allowed *C. acetobutylicum* DSM 1731 to produce solvents continuously (Bahl et al. 1982b). At the first stage, the cells are growing under

conditions that induce the onset of solvent production. At the second stage, growth is not possible because the limiting nutrient is exhausted, and this stage is thus devoted to the conversion of remaining sugar to solvents. The dilution rate and temperature were 0.125 h^{-1} and $37\text{ }^{\circ}\text{C}$ for the first stage and 0.04 h^{-1} and $33\text{ }^{\circ}\text{C}$ for the second stage. In a one-stage continuous culture, butanol and acetone concentrations as well as the rate of glucose consumption increased when the dilution rate was decreased from 0.13 to 0.025 h^{-1} . Although a low dilution rate favors a high product concentration, the productivity ($\text{gm of butanol}\cdot\text{liter}^{-1}\cdot\text{h}^{-1}$) decreased with decreasing dilution rate, and at dilution rates below 0.025 h^{-1} , stable culture conditions could no longer be obtained. A two-stage continuous culture of *C. acetobutylicum* ATCC 824 was operated at dilution rates of 0.08 and 0.04 h^{-1} for the first and second stages and yielded similar results (Godin and Engasser 1990).

A two-stage continuous culture, with on-line solvent removal by membrane evaporation, was carried out with *C. beijerinckii* NRRL B592 (Gapes et al. 1996). In this study, porous LECA (lightweight expanded clay aggregates) particles (particle size 5–10 mm) were included at both stages. The internal (accessible to cells) volume of the LECA particles represented 12 % and 15 % of the total volume (consisting of the working volume of the fermentor, the internal volume of the LECA particles, and the volume of the recirculation loop) of the first and second stages, respectively. The use of the LECA particles at both stages resulted in a significant increase in the final solvent concentration and solvent productivity at the second stage. The true dilution rate for each stage of the culture is difficult to determine because the medium inside the LECA particles must have a lower dilution rate than the medium outside the particles. Accordingly, the cells inside and outside of the LECA particles are likely at different physiological states. Continuous cultures of solvent-producing clostridia show periodic fluctuations of metabolic activities (known as metabolic oscillation). The inclusion of a membrane evaporation module in the recirculation loop of the second cultivation stage seems to reduce the magnitude of metabolic oscillations (Gapes et al. 1996). It should be informative to compare cells collected at different oscillatory cycles to see whether they represent different genotypic populations of cells, which differ in their capacity for substrate utilization, solvent production, and sporulation.

Active solvent production by *C. acetobutylicum* or *C. beijerinckii* at the second stage of a two-stage continuous culture may be analogous to solvent production in the batch culture, where solvent-producing cells are growing very slowly or not growing as they proceed to complete sporulation. Results suggest that the Spo0A regulatory protein is involved in the initiation of solvent production, besides its role in the initiation of sporulation (see the section [“Physiology of Solvent Production”](#) in this chapter). If active solvent production by the wildtype cell is limited to a period during which the cell does not commence new division (although the optical density of the culture continues to increase owing to an increase in cell mass), it becomes apparent that a true chemostat or continuous culture of the wildtype solvent-producing cells should be

■ Table 2.4

United States patents issued after 1981 for butanol production by fermentation

Patent no.	Date	Inventors	Title
4,326,032	1982	Grove, L. H.	Process for the production of organic fuel
4,368,056	1983	Pierce, S. M., Wayman, M.	Diesel fuel by fermentation of wastes
4,424,275	1984	Levy, S.	Continuous process for producing <i>n</i> -butanol employing anaerobic fermentation
4,443,542	1984	Hayashida, S., Ogata, S., Yoshino, S.	Process for the production of butanol and novel microorganism composition used therein
4,520,104	1985	Heady, R. E., Frankiewicz, J. R.	Production of butanol by a continuous fermentation process
4,521,516	1985	Lemme, C. J., Frankiewicz, J. R.	Strain of <i>Clostridium acetobutylicum</i> and process for its preparation
4,539,293	1985	Bergstrom, S. L., Foutch, G. L.	Production of butanol by fermentation in the presence of cocultures of <i>Clostridium</i>
4,560,658	1985	Datta, R., Zeikus, J. G.	Production of butanol by fermentation in the presence of carbon monoxide
4,568,643	1986	Levy, S.	Continuous process for producing <i>n</i> -butanol employing anaerobic fermentation
4,628,116	1986	Cenedella, R. J.	Vinyl bromide extraction of butyric acid and butanol from microbial fermentation broth
4,690,897	1987	Squires, C. H., Heefner, D. L., Evans, R. J., Kopp, B. J., Yarus, M. J.	Method for transformation of anaerobic microorganisms
4,757,010	1988	Hermann, M., Fayolle, F., Marchal, R.	Production of <i>Clostridium acetobutylicum</i> mutants of high butanol and acetone productivity, the resultant mutants, and the use of these mutants in the joint production of butanol and acetone
4,777,135	1988	Husted, G. R., Santangelo, J. D., Bostwick, D. W.	Method for producing butanol by fermentation
4,905,761	1990	Bryant, R. S.	Microbial enhanced oil recovery and compositions
5,063,156	1991	Glassner, D. A., Jain, M. K., Datta, R.	Process for the fermentative production of acetone, butanol, and ethanol
5,192,673	1993	Jain, M. K., Beacom, D., Datta, R.	Mutant strain of <i>C. acetobutylicum</i> and process for making butanol
5,210,032	1993	Kashket, E. R.	Degeneration-resistant solventogenic clostridia
6,358,717	2002	Blaschek, H., Annous, B., Formanek, J., Chen, C.-K.	Method of producing butanol using a mutant strain of <i>Clostridium beijerinckii</i>

difficult to maintain. For the same reason, cell immobilization or recycling will not be practical for continuous solvent production by the wildtype cells. However, appropriate asporogenous mutants (Meinecke et al. 1984; Lemme and Frankiewicz 1985), whose lesion is at a step beyond the onset of solvent production and sporulation, could allow the use of immobilized cells for continuous solvent production (Largier et al. 1985). New research in this area will probably use asporogenous or sporulation-deficient mutants that are selected for prolonged active solvent production.

Product Recovery

Solvent fermentation produces a dilute solution of butanol, acetone, or isopropanol. The recovery of these products by distillation is an energy-intensive process. Unless the final product concentrations are elevated, the development of alternative methods for product recovery may improve the economics of this fermentation. Techniques for the alternative methods could include the use of membranes (reverse osmosis, perstraction, pervaporation, and membrane evaporation),

adsorbents, liquid-liquid extraction, gas stripping, and chemical recovery methods (Dürre and Bahl 1996; Dürre 1998). Each of these techniques has its advantages and shortcomings, but all of them can be designed to allow on-line product recovery, which is desirable for a continuous solvent-production system (Gapes et al. 1996; Dürre 1998).

Pilot-Plant Studies

Since the 1980s, two studies of solvent fermentation at the pilot-plant scale have been reported. A pilot project was started in Soustons, France, to evaluate the commercial potential of producing solvents for gasoline-substitute fuels. It was designed to use mainly hydrolysates of cereal straw and corn stover as the substrates. The raw materials were pretreated by steam explosion and then hydrolyzed by *Trichoderma* cellulase complex to yield fermentable substrates, and the aim was to produce 1 t of solvents from 6 to 7 t of raw materials (Nativel et al. 1992; Nimcevic and Gapes 2000). Batch fermentations using strains of *C. acetobutylicum* were performed at 2-m³ and 50-m³ scales. Yields of 1 t of solvents from 7.7 t of corn cobs were reported.

Economic evaluation of the process revealed that the costs of acetone-butanol fermentation from lignocellulosic materials are strongly dependent on the market value of the by-product lignin (Marchal et al. 1992).

Another pilot-plant study was performed in Austria, using potatoes as the raw materials (Nimcevic and Gapes 2000). The pilot plant was designed for different modes of operation, including batch, fed-batch, and continuous. For continuous fermentation, potatoes were mashed and then liquified with a relatively small amount of amylase to prevent blockage of the equipment. The study used *C. beijerinckii* NRRL 592 and a two-stage setup (Gapes et al. 1996), with the longest continuous fermentation lasting about 4 weeks. The first-stage fermentor was a gas-lift bioreactor with a working volume of 50 l, and the second stage fermentor had a working volume up to 300 l and was equipped with an on-line gas-stripping unit. For product removal and recovery, different on-line and off-line techniques were tested, and they included distillation, vacuum distillation, rectification, gas stripping, and reverse osmosis. Membrane systems were not tested for product recovery at the pilot plant because it was assumed that the relatively low solvent flux through the membrane would require too large a membrane area for commercial operation. The results of the pilot-plant study have not been published yet. However, the solvent fermentation is attractive to certain localities because it provides an alternative to ethanolic fermentation: When there is a glut of ethanol, those regions which traditionally produce ethanol from surplus and waste starchy materials can now produce butanol and acetone or isopropanol instead (Gapes 2000b).

Economic Evaluation

Following the oil embargo in 1973 and the drastic rise in the price of crude oil, a renewed interest in the butanol-acetone fermentation has required periodic evaluation of the economic feasibility of this fermentation utilizing different substrates, engineering designs, and financing (Solomons 1976; Lenz and Moreira 1980; Gibbs 1983; Schoutens and Groot 1985). These studies considered molasses, milk whey, and lignocellulosic materials as the source of the carbohydrates for the fermentation, as the cost of the carbon substrate is invariably the largest single cost item. The question “where is the sugar to come from” (Solomons 1976) remains valid today. Evaluations utilizing corn or low-grade potatoes as the raw material yielded encouraging results (Gapes 2000a; Qureshi and Blaschek 2001).

The analysis by Gapes (2000a) shows that the process can be run economically in niche markets on a relatively small industrial scale, processing low-grade agricultural products. The niche market is usually a rural region where cheap, low-grade substrates are available and the conversion of the raw material into bulk chemicals meets the specific needs of the locality, as exemplified by the many small ethanol distilleries that have been operated around Europe for many decades. On the basis of the average world market price of butanol (0.61 EUR/kg) and acetone (0.45 EUR/kg) for the 5 years

preceding 2000, it was calculated that the break-even price of substrate lies between 0.05 and 0.09 EUR/kg for a grass-root plant or between 0.09 and 0.13 EUR/kg if an existing plant can be modified at low cost. The price of agricultural products, such as grains (primarily produced for food and feed), is thus too high under the conditions assumed in this analysis. Utilization of low-grade substrates, such as frozen potatoes, mycotoxin-contaminated corn, and surplus sugar beet, makes the fermentation economical. As suggested by several authors, butanol-acetone production by a fermentative process probably has higher capital costs but lower production costs than production by the petrochemical industry process. Gapes also suggests that from the viewpoint of investment costs alone, it is unlikely that a continuous operation is of great advantage because of the increased equipment cost for maintaining sterility during the fermentation.

The evaluation of a process using corn and the hyper-butanol-producing strain of *C. beijerinckii* BA101 in batch reactors at a plant with a capacity of 153,000 metric t per year of butanol, acetone, and ethanol gave the following results. At a corn price of US\$79.23 per ton (US\$2.01 per bushel) and a solvent yield of 0.42 g per g of glucose, the price for butanol is projected to be US\$0.34 per kg. If the price of corn is at US\$197.10 per t, the price of butanol rises to US\$0.47 per kg. Production from a grass-root plant would result in a butanol price of US\$0.73 per kg, when the price of corn is US\$79.23 per ton, or US\$0.88 per kg, when the price of corn is US\$197.10 per ton, or US\$1.07 per kg, when the price of corn is US\$197.10 per ton and no credit for gases is taken. In this evaluation, acetone and ethanol are treated as by-products, and a by-product credit is included in the calculation of the price of butanol. The price of petrochemical-derived butanol was US\$1.21 per kg as reported in the Oct. 16, 2000, issue of *Chemical Market Reporter* (Qureshi and Blaschek 2001).

Patents and Regulatory Issues

There are two periods during which the majority of patents for bacterial solvent production were issued. The first period is between 1910 and 1950, and the second period started in 1982. The first period is characterized by the use of newly isolated bacteria (Beesch 1952; Prescott and Dunn 1959a), whereas the second period is characterized by the use of mutant strains derived from organisms in the culture collections (► Table 2.4). Many of these patents have expired, but they continue to provide useful information for the correct identification and classification of industrial strains preserved in the culture collections (Jones and Keis 1995; Keis et al. 1995).

The new wave of patent applications coincided with the rise in interest in using fermentation as an alternative to the petrochemical-dependent synthetic routes for the production of butanol and acetone. For reasons of economics and environment protection, the use of industrial waste or lignocellulosic residues, instead of primary food products, as the substrates for the fermentation is desired (Pierce and Wayman 1983). There are propositions to use

butanol, acetone, or isopropanol as components of fuels (Grove 1982; Pierce and Wayman 1983) or to use solvents produced in situ for enhanced oil recovery (Bryant 1990). Another reason for making solvent fermentation important pertains to the desired use of fermentation-derived butanol as an extractant in the preparation of foods, flavors, and pharmaceuticals to reduce the potential of carcinogen carryover from the petroleum-based synthetic butanol (Blaschek et al. 2002).

Prospects

The demise of solvent fermentation in North America and East Asia between the late 1950s and the early 1960s resulted from both the competitive uses for molasses, which drove up the cost of raw materials, and the rise of the petrochemical industry, which drove down the price of the chemically synthesized butanol and acetone. However, this industrial fermentation did not totally disappear after the 1960s. The continued operation of the fermentation in South Africa between 1936 and 1982 illustrates the importance of the local conditions in determining the cost effectiveness and the necessity of the fermentation. The use of butanol as an extractant by the food and pharmaceutical industries may also create a demand for the fermentation product as it does not contain the carcinogens that may be present in butanol produced from petrochemicals. The continued use of the fermentation process to produce butanol in China may partly be due to this consideration.

With an increasing world population and an increased pressure to preserve the productivity of the land and the aquatic system, the use of petrochemicals and the further deterioration of the environment by pollution must be curtailed. Therefore, in addition to conserving the petroleum reserve, the production of valuable chemicals such as butanol, acetone, and isopropanol from fermentable wastes or low-grade agricultural products can also help to improve the quality of the environment as well as the economy of localities where such raw materials are generated. Results of economic evaluations indicate that butanol production by fermentation can be profitable in niche markets where the cost of raw material is kept low (Gapes 2000a; Qureshi and Blaschek 2001). The cost for raw material will probably remain the most significant item in the economics of solvent fermentation. The genome of *C. acetobutylicum* contains several sets of genes for the utilization of abundant and inexpensive polysaccharides. If solvents can be produced from lignocellulosic substrates, the fermentation will be even more attractive.

The economics of solvent fermentation can be further improved by increasing the final concentration of solvents in the fermentation broth so that the cost for product recovery is lowered. Although butanol is toxic to the cell, results of genetic manipulations show that significantly higher concentrations of butanol and acetone can be achieved when the metabolic machinery is altered, indicating that butanol toxicity is not the limiting factor for the final solvent concentration. Our understanding of the enzymology and regulation of solvent fermentation suggests that because of the shared regulatory element

(Spo0A) for the onset of both solvent production and sporulation and because of the cell's progression toward sporulation, active solvent production has a limited duration and hence productivity within the life cycle of a *Clostridium* cell. It is thus tempting to postulate that if the regulation for the onset of solvent production can be disconnected from the regulation for the onset of sporulation (or if the sporulation process can be delayed or interrupted), the period of active solvent production may be significantly prolonged to increase the final concentration of solvents. At present, it appears that isopropanol is a more desirable by-product than acetone for butanol fermentation because an adequate supply of acetone is available through phenol production. If there should be an additional demand for acetone or the route for acetone production changes, the product pattern can be adjusted through metabolic engineering so that the best combination is obtained.

1,3- and 1,2-Propanediol Production

Introduction

Three-carbon diols (1,3- and 1,2-propanediol) are of significant commercial interest. The first (1,3-propanediol; PDO; also known as "trimethylene glycol") can be produced by glycerol fermentation by several different microorganisms, including *Clostridium*, *Enterobacter*, *Klebsiella*, and *Lactobacillus* (Rayner 1926; Mickelson and Werkman 1940). The fermentative production was first described in 1881 (Biebl et al. 1999). The reader is referred to several reviews on microbial production of 1,3-propanediol (Deckwer 1995; Zeng et al. 1997; Cameron et al. 1998; Biebl et al. 1999). The second (1,2-propanediol; 1,2-PD; also known as "propylene glycol") is produced naturally by a few organisms such as *Thermoanaerobacterium thermosaccharolyticum* and various *Clostridium* spp. (Tran-Din and Gottschalk 1985; Cameron and Cooney 1986; Sanchez-Riera et al. 1987). *Escherichia coli* has been engineered to produce 1,2-propanediol, and this development may provide a competitive biotechnological route of production (Altaras and Cameron 2000). The microbial production of 1,2-propanediol has been summarized in reviews (Cameron et al. 1998; Bennett and San 2001).

Large quantities of 1,2-propanediol are made by a chemical process using propylene oxide as raw material. Consumption in the United States is estimated to be in the range of 850 million pounds per year (Ouellette 2000). Propylene glycol is a viscous liquid that is used primarily in unsaturated polyester resins. Pricing of propylene glycol, as listed in the January 1, 2001, issue of *Chemical Marketing Reporter*, is about US\$0.59 per pound. The relatively low cost of chemically produced propylene glycol makes it difficult for a biological process to compete economically.

On the other hand, 1,3-propanediol has been more difficult to produce via chemical synthesis, and for many years, its high price limited its application. Sold as a specialty chemical, 1,3-propanediol was priced in the range of US\$30/kg (Biebl et al. 1999). This high cost sparked interest in exploring the economics of a biological route, especially as PDO is a desirable

monomer for polymer synthesis. Deckwer (1995) estimated that the cost of 1,3-propanediol produced by fermentation was highly dependent on glycerol, the primary raw material. He estimated that more than 2/3 of the production cost of 1,3-propanediol was due to glycerol, which sells for about US\$0.65–0.80 per pound (Anonymous 2001a).

The prospects for 1,3-propanediol changed significantly when Shell Chemical announced the commercialization of a new polyester in 1995 called “Corterra.” This new polyester is a combination of terephthalic acid and 1,3-propanediol. The potential for widespread use of this polyester (polytrimethylene terephthalate [PTT]) lies in fiber applications, as it has excellent properties (Welling 1998). Shell developed a lower-cost chemical route to the monomer, but industrial interest in biotechnological routes remained.

As mentioned earlier, only a few microorganisms possess the ability to ferment glycerol anaerobically to 1,3-propanediol. Glycerol is converted to pyruvate through dihydroxyacetone phosphate. In *Klebsiella*, the pyruvate is cleaved to acetyl-CoA and formate, with ethanol, acetate, CO₂, and H₂ being generated. A balance of reducing equivalents is required, resulting in the conversion of glycerol to 3-hydroxypropionaldehyde via a vitamin B12-dependent glycerol dehydratase and then subsequent reduction to 1,3-propanediol (Streekstra et al. 1987). DuPont and Genencor undertook a new biotechnological approach (adding genes to propanediol-producing hosts that allowed for the usage of dextrose as the substrate; Chotani et al. 2000). With the number of tools in molecular biology increasing and the potential benefits of constructing new pathways, the metabolic engineering approach toward production of 1,3-propanediol has become an important one (Cameron et al. 1998).

The anaerobe *Thermoanaerobacterium thermosaccharolyticum* can produce 1,2-propanediol from dextrose, whereas other microorganisms use costly 6-deoxysugars. Propylene glycol produced by chemical means is a mixture of R and S isomers. The pure R enantiomer, which may have added value as a chiral molecule, is produced by microbial processes. This organism can produce 1,2-propanediol from a variety of sugars, which may help lower the cost of production (Altaras et al. 2001). The naturally occurring strains do not produce 1,2-propanediol at high amounts, so an alternate approach involving metabolically engineered *E. coli* was followed. *Escherichia coli* typically makes 1,2-propanediol from costly 6-deoxyhexose sugars; however, expression of either glycerol dehydrogenase or methylglyoxal synthase resulted in anaerobic production from glucose (Altaras and Cameron 1999). Many challenges still remain in the development of a bioprocess that can be competitive with the chemical route in the production of 1,2-propanediol.

To become competitive with a chemical process, one that is microbially based must overcome hurdles: (1) the cost of agricultural raw material versus the relative low cost of petrochemical feedstocks and (2) purification, including both water removal and separation from a complex mixture. The approaches described in subsequent sections focus on using lower-cost raw material and achieving gains in yield and titer.

Scientific Background

1,3-Propanediol

The study of microbial production of 1,3-propanediol has an interesting history (reviewed by Biebl et al. 1999). It is one of the oldest fermentation products known and has been studied for over 100 years. For a number of years, interest in the fermentation was due to its potential as an outlet for surplus glycerol. Glycerol can be made via a chemical process, or it can be derived from various agricultural fats during the production of fatty acids and soaps. Increased availability of low-cost glycerol might be expected in the future, as it is a by-product of such processes as transesterification of fats for biodiesel production as well as the process for ethanol production by yeast.

Glycerol can be used aerobically for growth by a large number of microorganisms. Very few organisms are able to form PDO, which is typically formed as an anaerobic product of glycerol. Only bacteria in the genera *Klebsiella*, *Enterobacter*, *Citrobacter*, *Lactobacillus*, *Clostridium* (Biebl et al. 1999), and *Ilyobacter* (Stieb and Schink 1984) have been shown to make PDO. Most of the work has been done utilizing *Klebsiella*, *Enterobacter*, and *Clostridium* (Heyndrickx et al. 1991; Bouvet et al. 1994; Barbirato et al. 1995, 1996a; Petitdemanche et al. 1995; Solomon et al. 1995; Zeng 1996; Ahrens et al. 1998; Biebl et al. 1998).

Glycerol is converted via two pathways: an oxidative one to pyruvate and a reductive pathway to PDO. The oxidative pathway involves a NAD⁺-linked enzyme, glycerol dehydrogenase, which converts glycerol to dihydroxyacetone. Interestingly, dihydroxyacetone has uses in the cosmetics industry (Barbirato et al. 1998). Dihydroxyacetone is then phosphorylated by DHA kinase and is then further metabolized to pyruvate through glycolytic reactions. From pyruvate, a mixture of end products is formed that varies among the different anaerobic glycerol utilizers (Forage and Lin 1982). The oxidative and reductive pathways are shown in  Fig. 2.3.

In the reductive pathway, 3-hydroxypropionaldehyde is formed by the action of a vitamin B12-dependent glycerol dehydratase. The 3-hydroxypropionaldehyde is then reduced by the enzyme 1,3-PD dehydrogenase. The oxidative and reductive pathways of glycerol dissimilation form a balance, as the role of the PDO pathway is to regenerate reducing equivalents in the form of reduced nicotinamide dinucleotide (NADH₂) produced from the dihydroxyacetone pathway (Deckwer 1995; Zeng et al. 1997; Cameron et al. 1998).

The genes for the anaerobic dissimilation of glycerol are termed “the *dha* system.” Dihydroxyacetone and glycerol are inducers of glycerol dehydrogenase, dihydroxyacetone kinase, glycerol dehydratase, and 1,3-PD dehydrogenase (Forage and Foster 1982). Each of these genes and the resulting gene products have been studied in some detail and will be discussed below.

The first gene of the oxidative pathway is a NAD⁺-linked glycerol dehydrogenase. The enzyme differs from other glycerol dehydrogenases such as the one found in *E. coli*. *Escherichia coli* does not contain the *dha* genes but rather uses glycerol aerobically via an ATP-dependent kinase and an

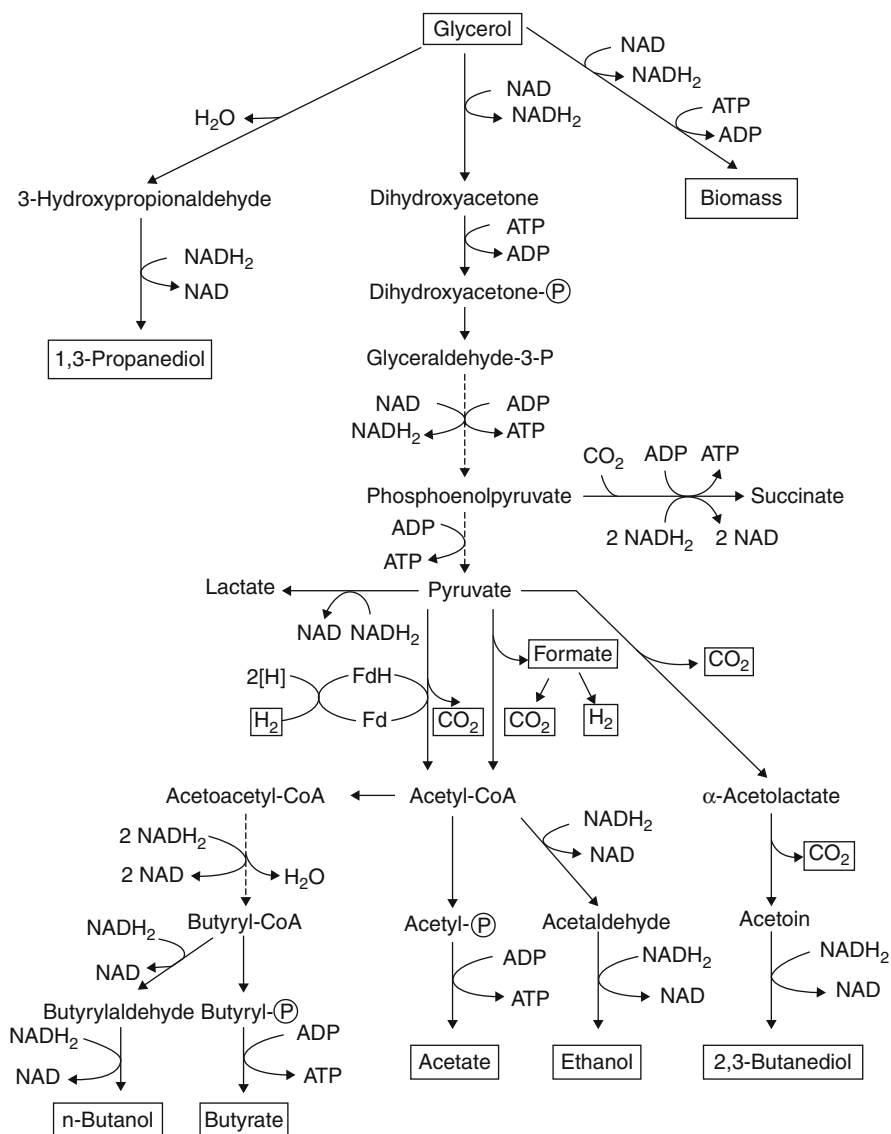

■ Fig. 2.3
Biochemical pathways of glycerol fermentation of representative microorganisms. From Biebl et al. (1999), with permission

sn-glycerol-3-phosphate dehydrogenase (St Martin et al. 1977). However, a NAD^+ -glycerol dehydrogenase was isolated from a mutant *E. coli* strain with defects in two genes for aerobic glycerol dissimilation, which provided a forced selection for growth on glycerol. This glycerol dehydrogenase was purified and studied and was found to have a broad substrate specificity, including glycerol as well as a number of substituted diols (Tang et al. 1979). This *E. coli* enzyme was studied and found to be immunochemically similar to a glycerol dehydrogenase in *Klebsiella pneumoniae* but not to the glycerol dehydrogenase of the *dha* system (Tang et al. 1982). This gene was later identified as *gldA* and is identical to D-1-amino-2-propanol oxidoreductase of *E. coli*. It maps near the *glpFKX* operon, and hydroxyacetone was shown to induce its expression (Trunger and Boos 1994).

Glycerol dehydrogenase (E.C. 1.1.1.6) and dihydroxyacetone kinase (EC 2.7.1.29) were cloned and purified from *Citrobacter*

freundii. Glycerol dehydrogenase is a hexamer of a polypeptide of 43 kDa. Like the *E. coli* glycerol dehydrogenase, the *Citrobacter* enzyme also has a broad substrate specificity. The DHA kinase is a dimer of a 57-kDa polypeptide. This enzyme is very specific for its substrates dihydroxyacetone and ATP. DHA kinase shows some structural similarities to the glycerol kinase of *E. coli*. The glycerol dehydrogenase gene and the DHA kinase gene were denoted “*dhaD*” and “*dhaK*,” respectively (Daniel et al. 1995b).

The *Citrobacter freundii* gene for 1,3-propanediol dehydrogenase (*dhaT*) has been cloned and overexpressed in *E. coli*. The enzyme is made up of eight identical subunits of 43.4 kDa and is able to catalyze a number of oxidation and reduction reactions. The enzyme oxidized a number of alcohols and was most active with diols containing two primary alcohol groups separated by one or two carbon atoms. This dehydrogenase reduced several aldehydes, with its greatest activity toward 3-hydroxypropionaldehyde. The authors compared the sequence of the

C. freundii enzyme with alcohol dehydrogenases and concluded that it belonged to a novel family of type III alcohol dehydrogenases (Daniel et al. 1995a). The *dhaT* gene was also cloned from *C. pasteurianum*, and it showed an 89.8 % similarity to the *C. freundii* gene (Luers et al. 1997).

The enzyme 1,3-propanediol dehydrogenase has also been purified from *E. agglomerans* and showed a pH optimum of 7.8. The enzyme was inhibited by NAD^+ and PDO, which may help to explain the finding that *E. agglomerans* accumulates 3-hydroxypropionaldehyde (Barbিরato et al. 1997b).

Glycerol dehydratase is a key enzyme in the production of PDO from glycerol. It has been proposed that it is the rate-limiting step in PDO formation for *C. butyricum* (Abbad-Andaloussi et al. 1996), *K. pneumoniae* (Ahrens et al. 1998), and *C. freundii* (Boenigk et al. 1993). The enzyme has been purified, and it requires coenzyme B12 (adenosylcobalamin) for activity (Schneider et al. 1970). The genes from *Citrobacter freundii* (Daniel and Gottschalk 1992; Seyfried et al. 1996), *Clostridium pasteurianum* (Macis et al. 1998), *Klebsiella pneumoniae* (Tobimatsu et al. 1996), and *Klebsiella oxytoca* (Tobimatsu et al. 1995) have been cloned and studied. The enzymes have sequence homology and similar substrate specificities and catalyze the conversion of 1,2-diols to deoxy aldehydes. The enzymes are similar in molecular weight and are made up of three subunits. In *Citrobacter freundii*, the enzyme is $\alpha 2\beta 2\gamma 2$ and has a molecular weight of approximately 196 kDa (Seyfried et al. 1996).

The *dha* genes from *Klebsiella pneumoniae* were imported by conjugation into *E. coli*. The *E. coli* was then able to grow anaerobically on glycerol, but it did not produce PDO. All enzymes of the *dha* regulon were detected except for glycerol dehydratase. The growth yield of the *E. coli* was reduced and may be explained by the lack of glycerol dehydratase and difficulties in achieving redox balance (Sprenger et al. 1989). The presence of adenosylcobalamin was shown to be important for functioning of glycerol dehydratase. Addition of this cofactor and reduction of growth temperature from 37 °C to 28 °C restored glycerol dehydratase activity and allowed *E. coli* to produce PDO from introduced *C. freundii* *dha* genes (Daniel and Gottschalk 1992).

In a different study, PDO production from glycerol was seen using *E. coli* containing cosmid vector-introduced *K. pneumoniae* genes. The yield of PDO from glycerol in complex media was much higher than in defined media. The yield of 0.46 moles/mole was comparable to that reported for the *Klebsiella*, which was the source of the *dha* genes. In this case, apparently the glycerol dehydratase functioned in *E. coli*, and the authors speculate that this could be due to the large size of the DNA insert (Tong et al. 1991).

Glycerol dehydratase is inactivated by its substrate, glycerol. In *Citrobacter freundii*, *dhaF* and *dhaG* were identified as being responsible for reactivation of glycerol dehydratase. Coenzyme B12, ATP, and Mg^{+2} were necessary for this reactivation. By transcriptional analysis, these two genes were shown to be expressed in glycerol but not glucose grown cells. The *dhaF* and *dhaG* subunits were purified and shown to form a tightly

bound complex with a molecular mass of 150 kDa. The purified complex was tested for its ability to reactivate glycerol dehydratases of *C. freundii*, *K. pneumoniae*, *C. pasteurianum*, and the diol dehydratases of *K. oxytoca*, *Salmonella typhimurium*, and *Propionibacterium freudenreichii*. The *C. freundii* and *K. pneumoniae* dehydratases were the only enzymes reactivated, which indicated that the *dhaF-dhaG* complex is specific for glycerol dehydratases of closely related organisms and does not function to reactivate diol dehydratases (Seifert et al. 2001). Similar reactivation gene products were found in *Klebsiella oxytoca* and were named “*ddrA*” and “*ddrB*” (Tobimatsu et al. 1999).

The genes encoding for glycerol dehydratase in *C. freundii* are the *dhaBCE* genes, which form part of the *dha* regulon. As mentioned earlier, the other key enzymes (*dhaD*, *dhaK*, and *dhaT*) form part of the pathway. There is also a transcriptional activator protein *dhaR* (Daniel et al. 1999). The genes encoding for glycerol dehydratase in *Klebsiella oxytoca* are termed “*pddA*,” “*pddB*,” and “*pddC*” (Tobimatsu et al. 1995).

The mix of products derived from the dihydroxyacetone to pyruvate pathway varies depending on the microorganism. *Klebsiella* can produce ethanol, formate, acetic acid, and 2,3-butanediol, while *Clostridium* can also produce butyric acid. Some strains of *C. pasteurianum* also form butanol (Heyndrickx et al. 1991). The pathways of glycerol fermentation and subsequent pyruvate use as drawn by Biebl et al. (1999) are shown in Fig. 2.3. The mix of products varies depending on the organism and the growth conditions, including pH and glycerol concentration.

Effort in calculating the theoretical yields of PDO and the mix of products formed has been considerable. To achieve economic production and maximize PDO yield, it is desirable to understand and eventually optimize by-product formation. The story is a complex one, as many different growth conditions have been examined and a variety of responses from different microorganisms can be seen.

The formation of PDO and its by-products under different conditions has been measured for *Klebsiella* and *Clostridium*, and some examples are given in the following paragraph. Using *Klebsiella aerogenes* NCTC 418, various growth-limited conditions were measured in an anaerobic chemostat. Under glycerol-limited conditions, energy generation was lower than expected owing to PDO formation. Under other growth-limiting conditions such as phosphate, ammonia, or sulfate limitation, it was found that the products acetate, ethanol, succinate, and PDO were formed but in differing amounts depending on the limitation. When glycerol was given in a pulse to glycerol-limited cultures, the glycerol was consumed quickly with most of the glycerol being converted to PDO and acetate (Streekstra et al. 1987).

A calculation of theoretical yield was done for *Klebsiella pneumoniae*. Two separate cases for ATP generation were assumed, one for acetic acid production and the other for ethanol. The acetic acid pathway was calculated to have a five times higher PDO yield than the ethanol pathway, while the ethanol pathway gave higher biomass and ATP yields. The theoretical maximum yield when acetate and not

ethanol is produced is 0.64 moles of PDO/mole of glycerol (Zeng et al. 1993).

The theoretical yields for various conditions were calculated for *C. butyricum* and tested in chemostat culture. The products butyrate and/or acetate are necessary for generating ATP for biosynthesis. Butyrate production is more efficient for biomass synthesis as it yields a higher amount of ATP. The maximum PDO production occurs when butyrate and hydrogen are not produced. The theoretical maximum PDO yield is 0.72 moles of PDO/mole of glycerol in the case of no butyrate and no hydrogen formation.

The theoretical results were compared with experimental data of *C. butyricum* grown under glycerol limitation and excess in continuous culture. Significant differences were seen with the highest yield value of PDO seen under conditions of glycerol excess. The effects of dilution rate in continuous culture were also measured on *K. pneumoniae* and *C. butyricum*. Both reached about 80 % of the theoretical maximum under high dilution rate, while *Klebsiella* reached a much higher yield and productivity under low dilution rate (Zeng 1996).

Zeng et al. (1997) summarized this work and wrote equations for the biomass yield and the formation of various products by *C. butyricum*. The equation for biomass formation is

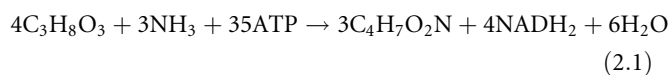

For acetate formation:

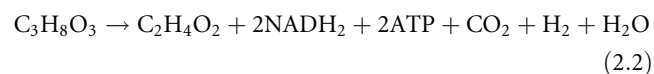

For butyrate formation:

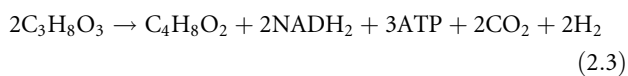

For 1,3-propanediol formation:

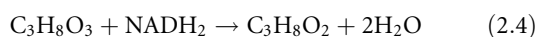

The equations represent reactions in the glycerol fermentation that the cell needs to regulate to achieve an overall balance in energy generation, reducing equivalents, and biomass. The various reactants are balanced in the overall cell metabolism. The authors calculated cases where either one or the other pathway is the only one used for energy generation and with maximum or no H₂ formation. The acetic acid pathway gave a PDO yield about 30 % higher than butyric acid formation, with a theoretical maximum PDO yield of 0.65 moles of PDO/mole of glycerol with H₂ formation. Thus, the acetate pathway is more attractive for PDO production (Zeng et al. 1997).

When *Enterobacter agglomerans* is grown anaerobically in a chemostat with glycerol, PDO is the major product, and acetate, ethanol, and formate are also produced in significant amounts, while lactate and succinate are minor products. When *E. agglomerans* is grown on glucose, PDO is not made and the enzymes of the *dha* regulon are decreased by 30- to 120-fold. The effects of different growth rates were also measured.

When the dilution rate increased from 0.05 to 0.31 h⁻¹, the activities of the enzymes of the oxidative pathway (glycerol dehydrogenase and DHA kinase) decreased 2.5-fold. With the higher dilution rate, glycerol dehydratase increased 34-fold and the 1,3-propanediol dehydrogenase level remained stable. Enzymes of central metabolism, glyceraldehyde-3-phosphate dehydrogenase, pyruvate kinase, and pyruvate formate lyase all increased slightly, except for pyruvate dehydrogenase, which was reduced slightly. Pyruvate dehydrogenase, which is normally expressed aerobically, does appear to be responsible for a portion of the carbon flow in *E. agglomerans* under anaerobic glycerol-utilizing conditions. The flow of pyruvate through pyruvate formate lyase was reduced at higher dilution rate (Barbirato et al. 1997a).

Hydrogen is generated during glycerol fermentation, and it should not be considered as merely a waste product. When anaerobic growth under low residual glycerol was compared for *C. butyricum* and *K. pneumoniae*, it was *K. pneumoniae* that was able to incorporate more of the glycerol electrons into hydrogen. When various media components such as phosphate, ammonia, and sulfate are limited, hydrogen but not PDO formation is also limited (Solomon et al. 1994).

The balance and recovery of reducing equivalents in glycerol fermentations are important to the final yield. Data from various authors were compared for *K. pneumoniae* fermentations run under different glycerol concentrations. Under glycerol limitation, a portion of the NADH₂ released from the dehydrogenases is oxidized through pathways other than those leading to PDO, ethanol, lactate, and 2,3-butanediol. These reducing equivalents are discharged by the cell as molecular hydrogen. In cultures with glycerol excess, the majority of reducing equivalents appear in PDO and only a small part is released as hydrogen. The authors suggest that the interconversion of NADH₂ and H₂ is mediated by pyruvate:ferredoxin reductase and hydrogenase (Zeng et al. 1993). This mechanism is also likely operating in *Clostridium*, as with some strains of *Clostridium*, the theoretical yield of PDO was exceeded and it was attributed to some portion of ferredoxin-bound molecular hydrogen transferring reducing equivalents to NAD, which was used to reduce additional glycerol to PDO (Biebl et al. 1992).

Much of the work on PDO production has been done with only a few strains. Various laboratories have gone to various environments to isolate new PDO producers to look for microorganisms with potentially superior properties. For example, several strains were isolated from sewage sludge, and the PDO yield and mix of products were compared. These isolates were identified as *Klebsiella* and *Citrobacter*. The *Citrobacter* strains yielded primarily PDO and acetic acid, with only small quantities of lactic acid and ethanol formed, while the *Klebsiella* strains produced more ethanol and lactic acid. *Citrobacter* had a higher product yield than *Klebsiella*, yielding 0.65 moles/mole of glycerol compared to the *Klebsiella* yield of 0.53 moles/mole of glycerol. *Citrobacter* had an overall productivity lower than that of one of the *Klebsiella* strains, as *K. pneumoniae* DSM 2026 had the highest titer and the best productivity (Homann et al. 1990).

The ability to use glycerol is not widely distributed among the *Clostridium*. A number of clostridial strains from culture collections were tested which did not grow on glycerol. Using a selection of growth on glycerol, four strains were isolated from soil and mud samples. All were identified to be *C. butyricum*. The most active strain, designated “SH1” and deposited as DSM 5431, was able to produce 56 g/l of PDO in 29 h from 110 g/l of glycerol in a batch fermentation (Biebl et al. 1992).

Additional PDO-producing *Clostridia* have been isolated and their by-products have been characterized. Strains of *C. butyricum* and *C. pasteurianum* were examined for both solvent and hydrogen production from glycerol. In batch fermentations, *C. butyricum* LMG 1212 t3 converted glycerol to PDO, and the addition of acetate increased glycerol utilization fourfold with more hydrogen and butyrate and less PDO formed. The other strain examined, *C. pasteurianum* LMG 3285, used most of the glycerol in the presence or absence of acetate and produced mainly butanol and hydrogen, along with butyrate, ethanol, acetate, formate, and PDO (Heyndrickx et al. 1991).

Several enterobacteria were compared for their ability to produce PDO. *Escherichia coli* lacks the *dha* regulon and is able to grow on glycerol using only the genes of the *glp* regulon, which require the presence of molecular oxygen or nitrate as an exogenous electron acceptor. *Klebsiella pneumoniae* is known to utilize glycerol and produce PDO whereas *Klebsiella oxytoca* made much less PDO from glycerol. *Klebsiella planticola*, *Klebsiella ozaenae*, *Klebsiella rhinoscleromatis*, and *Hafnia alvei* did not produce PDO from glycerol. Some of the *Klebsiella* did not possess a *dha* regulon, while others demonstrated activity of some of the enzymes in the pathway. *Klebsiella oxytoca* had 1,3-propanediol dehydrogenase activity and no glycerol dehydratase activity. *Klebsiella ozaenae* has only glycerol dehydrogenase activity (Bouvet et al. 1994). Like among the clostridia, the ability to grow anaerobically on glycerol and form PDO does not appear to be widespread among species of *Klebsiella*.

A microorganism isolated from the anoxic mud of a distillery wastewater digester, *Enterobacter agglomerans*, was also shown to ferment glycerol to PDO. Acetate is the primary by-product, but formate, ethanol, succinate, and lactate are also formed. The initial concentration of glycerol affects the fermentation profile of products. At the high glycerol concentration of 100 g/l, the PDO yield is higher, lactate concentration is reduced, and ethanol is not produced. Acetate was the primary by-product formed that generated ATP. At high glycerol concentrations, the substrate was not completely consumed, which suggested the accumulation of an inhibitory factor (Barbirato et al. 1995).

The inhibitory compound (3-hydroxypropionaldehyde) accumulates when glycerol is added at high initial concentrations. The highest levels are seen in *E. agglomerans*, but 3-hydroxypropionaldehyde is also observed in cultures of *C. freundii* and *K. pneumoniae* grown in high glycerol concentrations. Both natural and synthesized 3-hydroxypropionaldehyde were shown to have a bacteriostatic effect (Barbirato et al. 1996a). Culture pH affected 3-hydroxypropionaldehyde

formation, as it accumulated much earlier at pH 6 compared to pH 8. As 3-hydroxypropionaldehyde accumulated, the NAD/NADH ratio increased. The authors propose that the PDO dehydrogenase is inhibited by NAD, and this increased nucleotide ratio could be responsible for the accumulation of 3-hydroxypropionaldehyde. The effects of 3-hydroxypropionaldehyde were measured on the activity of the enzymes involved in the anaerobic dissimilation of glycerol, and the enzyme glycerol dehydrogenase demonstrated the greatest sensitivity (Barbirato et al. 1996b).

The fermentation of glycerol to PDO is also sensitive to the various products produced. By use of a pH auxostat, growth of *Clostridium butyricum* was shown to be inhibited by concentrations of 60 g/l of PDO, 27 g/l of acetic acid, and 19 g/l of butyric acid. Since acetic and butyric acid would be produced at lower levels in a typical fermentation, the inhibition by PDO is expected to be the most important consideration. Butyric acid appears to be more toxic than acetic acid. The undissociated forms of the acids are responsible for the inhibitory effects in fermentation (Biebl 1991).

Externally added acids appear to have a two- to threefold lower inhibition than those produced by the microorganism, which could be attributed to transport through membrane lipids (Zeng et al. 1994b). The time of addition of PDO also affects its inhibition, as an initial PDO concentration of 65 g/l stops glycerol fermentation, whereas with an initial concentration of PDO (50 g/l) and glycerol (70 g/l), the final PDO concentration reaches 83.7 g/l with complete consumption of glycerol (Colin et al. 2000). This suggests that high PDO concentrations inhibit growth but not the actual PDO formation.

1,2-Propanediol

The chemical synthesis of 1,2-propanediol (1,2-PD) results in the mixture of the R and S isomer. Direct fermentation processes yield either the R or the S isomer, which may provide an advantage as a chiral synthon. Two main biochemical processes for the synthesis of 1,2-PD are known. The first pathway involves the metabolism of deoxyhexoses through the intermediate lactaldehyde. In the second pathway, methylglyoxal (Inoue and Kumura, 1995) is derived from dihydroxyacetone phosphate, and methylglyoxal is reduced to 1,2-propanediol. The microbial formation is covered in reviews (Cameron et al. 1998; Bennett and San 2001).

The formation of 1,2-propanediol by catabolism of 6-deoxyhexose sugars such as fucose and rhamnose by bacteria and yeast has been known for many years (Suzuki and Onishi 1968; Ghazvinizadeh et al. 1972; Cocks et al. 1974; Turner and Robertson 1979; Weimer 1984b). This pathway forms S-1,2-propanediol through cleavage of the sugar into dihydroxyacetone phosphate and S-lactaldehyde, which are then reduced to S-1,2-propanediol. A low-cost source of these 6-deoxysugars is not readily available, making this fermentation route impractical. A diagram of the pathway as it is understood is below and taken from the review by Bennett and San (Bennett and San 2001;  Fig. 2.4).

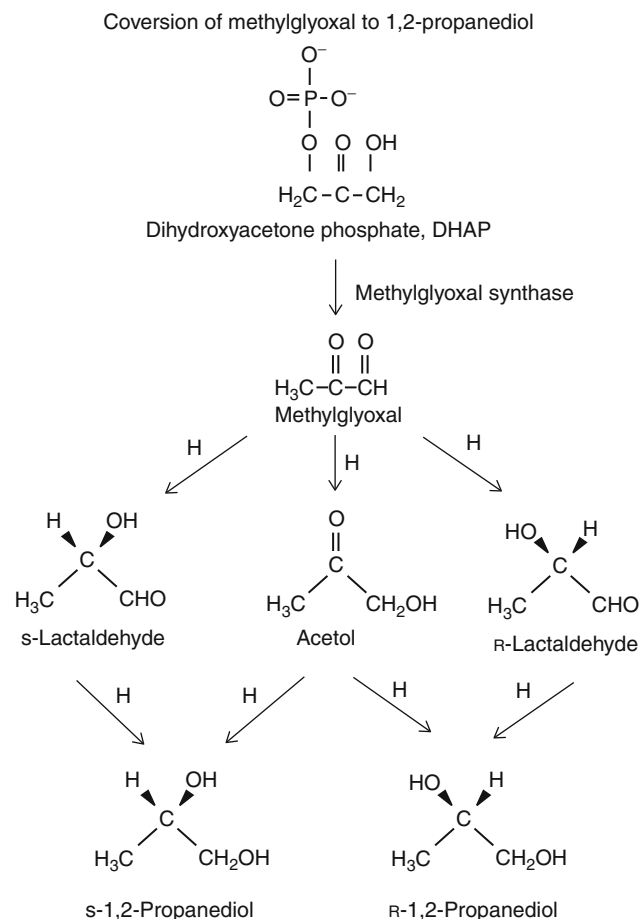

Fig. 2.4

Conversion of deoxy sugars to 1,2-propanediol (From Bennett and San (2001), with permission)

Clostridium sphenoides DSM 614 was shown to form both D(-)-1,2-PD and D(-)-lactate from glucose but only under phosphate limiting conditions. Ethanol and acetate were the major products at a phosphate concentration of 0.4 mM and above. The 1,2-PD formation began at phosphate concentrations below 80 μ M. Lactate also increased under low phosphate conditions. Besides glucose, 1,2-PD was formed from D-fructose, cellobiose, L-rhamnose, and L-fucose. The activities of the enzymes methylglyoxal synthase, methylglyoxal reductase, and 1,2-PD dehydrogenase were all detected in the cell. Methylglyoxal synthase, the first enzyme of the methylglyoxal bypass, is strongly inhibited by phosphate (Tran-Din and Gottschalk 1985). The possible routes to 1,2-propanediol are summarized by Bennett and San (Bennett and San 2001; Fig. 2.5).

Besides *Clostridium sphenoides*, the organism *Clostridium thermosaccharolyticum* (now called "*Thermoanaerobacterium thermosaccharolyticum*") also produces R-1,2-PD and acetol from glucose. Other products made include acetate, ethanol, and lactate. In a fed-batch fermentation, the yield of 1,2-PD on glucose was 0.27 g/g at 30.7 h. The maximum titer reached was 7.9 g/l. In contrast to *C. sphenoides*, the *C. thermosaccharolyticum*

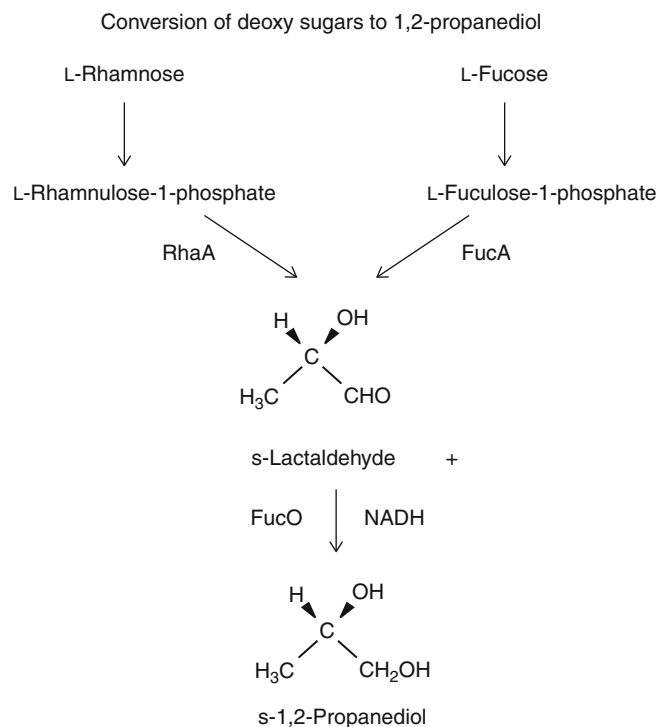

Fig. 2.5

Routes to 1,2-propanediol synthesis through methylglyoxal (From Bennett and San (Bennett and San 2001), with permission)

production of 1,2-PD was not enhanced by phosphate limitation. A maximum theoretical yield of 0.42 g of 1,2-PD per gram of glucose was calculated (Cameron and Cooney 1986).

A novel route to 1,2-PD by the anaerobic conversion of lactic acid by *Lactobacillus buchneri* was described. Lactic acid had been shown to disappear in silage inoculated with *L. buchneri*. This organism anoxically converts 2 moles of lactic acid to 1 mole of acetic acid and 1 mole of 1,2-propanediol. This conversion does not occur unless the organism is at a pH below 5.8. In the proposed pathway, 1 mole of lactic acid is converted to 1,2-PD through lactaldehyde, while the other mole of lactic acid is converted through pyruvate to acetate (Oude Elferink et al. 2001).

The enzyme methylglyoxal synthase, which catalyzes the conversion of dihydroxyacetone phosphate to methylglyoxal, has been cloned from *Clostridium acetobutylicum* and expressed in *E. coli*. This enzyme has been found in number of bacteria. The clostridial enzyme has a pH optimum of 7.5, and when dihydroxyacetone phosphate, glyceraldehyde, and glyceraldehyde-3-phosphate were examined as substrates, only dihydroxyacetone phosphate could be converted to methylglyoxal (Huang et al. 1999). Other work with this pathway has included improvement of the *Thermoanaerobacterium thermosaccharolyticum* fermentation as well as the metabolic engineering of *E. coli* to produce 1,2-PD. This work will be discussed in the section "Research and Development" in this chapter.

Commercial Applications

The product 1,3-propanediol and the properties of polytrimethylene terephthalate (PTT) were discovered in the early 1940s, but the high cost of PDO manufacture inhibited widespread commercial use (Anonymous 1999a, b). In the mid-1990s, Shell Chemical Company announced that it had developed a new chemical route to the production of PDO. It called its new PTT-based fiber "Corterra." Shell's process uses a hydroformylation of ethylene oxide and recovers the intermediate 3-hydroxypropionaldehyde which is then hydrogenated to PDO. Water and impurities are removed to produce a fiber-grade PDO (Shelley and D'Aquino 1999). Shell first constructed a small development plant that had a nameplate capacity of 3,200 metric t per year. It has constructed a world-scale PDO plant at Geismar, Louisiana, with a capacity of 75,000 metric t per year that was scheduled to be on-line in late 1999. This is enough PDO to make just under 300,000 metric t of PTT. The true potential of this new polymer may be in replacing large parts or all of the polyethylene terephthalate market (PET), which worldwide is around 20 million metric t (Greenberg 1999).

Degussa developed a chemical synthesis process for PDO in which propylene is catalytically converted to acrolein, which is then hydrated to 3-hydroxypropionaldehyde. PDO is formed by hydrogenation, and fiber-grade material is produced by distillation. This technology was licensed by DuPont, and Degussa and DuPont have been working together to produce PDO at a 20-million-lb/year facility in Germany that came on-line in 1998. DuPont has named their polyester "Sonora." The polypropylene route is not believed to be as economical as the ethylene oxide route, primarily owing to the cost of the process plant (Shelley and D'Aquino 1999).

DuPont is pursuing a third route to PDO, with a bioprocess that uses glucose as a starting material. This work has been done in collaboration with Genencor (Potera 1997). The anaerobic conversion of glycerol to 1,3-propanediol was well known and has been documented in the scientific literature over many years. The DuPont and Genencor team of scientists created a microorganism that was able to convert carbohydrate to PDO, or "3 G" as it is referred to by DuPont (Shelley and D'Aquino 1999). With this new technology, low-cost renewable resources can be used as a raw material source. A glycerol dehydratase or diol dehydratase enzyme is expressed in a microorganism such as *E. coli*, which is able to utilize sugars such as glucose. Initial results showed that the level of PDO produced by recombinant microorganisms was very low (Laffend et al. 1997).

DuPont and Genencor have reported a 500-fold improvement in productivity (Moore 1999). They announced that they would extend their research and development (R&D) collaboration through the end of 2001. DuPont is scaling up the bioprocess by an announced joint venture with Tate and Lyle. At their Decatur, Illinois, corn-wet mill, A.E. Staley, a subsidiary of Tate and Lyle, produces raw materials from renewable resources such as corn. PDO production is being tested by

DuPont at a 200,000-lb/year pilot plant there, and DuPont has said that it expects commercialization of the bio-based PDO in 2003 (Wood 2001). Though the product can in part be called a "green" chemical since the PDO is derived from renewable resources, the terephthalate part of the polymer is derived from petrochemicals.

In large, commodity-scale fermentations such as this one, the price of raw materials is significant and can account for 70 % or more of total cost (Wilke 1999). The variability in supply and raw material cost can affect the cost of production. Since most of the scientific effort on PDO in the past was conversion of glycerol, the DuPont/Genencor process should represent a potential cost advantage since it is based on glucose. Glycerol prices range between US\$1 and \$2/kg. At the yield of around 50 % on glycerol, the cost of PDO would be high compared to production on glucose, which sells for below US\$0.20 per pound (Wilke 1999).

The long-term prospects for PDO appear excellent, as the fibers made from PTT are expected to compete with nylon and spandex and are touted to have superior properties. According to Shell, PTT fibers are chemical and stain resistant but have elasticity and good colorfastness. The fibers also dye easily and will be priced in the range of \$US0.90–1 per pound. The Shell Corterra fiber won the R&D magazine award as one of the most technologically significant new products in 1998 (Welling 1998). Besides apparel, the fibers can be used in carpet, engineering thermoplastics, and nonwovens. Other potential commercial applications include paints, adhesives, laminates, and coatings (Anonymous 1999a, b).

While PDO use is just beginning to grow and become a large-volume commodity chemical, propylene glycol is already made in vast quantities. Total production in the United States is estimated at over one billion pounds, with unsaturated polyester resins accounting for about 25 % of the demand (Ouellette 2000). One of the major uses of unsaturated polyester resins (UPR) is in construction, and demand for UPRs and hence propylene glycol is driven by the strength of the economy. As propylene glycol is safer than ethylene glycol, its use in antifreeze has climbed so that almost one-fifth of the demand for propylene glycol goes to antifreeze. Other uses for propylene glycol include liquid laundry detergent, pharmaceuticals and cosmetics, and other miscellaneous uses (Anonymous 1996a). The fact that it is clear and also has good emollient properties makes it desirable for these uses. Propylene glycol is "generally regarded as safe" (GRAS) by the United States Food and Drug Administration and has use in human foods and certain animal foods.

The demand for propylene glycol is expected to grow about 3 % per year in the United States. The manufacture is by a chemical process using hydration of propylene oxide. Propylene oxide is made from propylene, and prices of propylene have increased, tied to oil price increases. Propylene oxide also enjoys a high demand due to the growth of its biggest end use, polyurethanes (Ouellette 2000). With propylene oxide costs being between \$US0.20 and 0.30 per pound, it is difficult to envision a biological route to propylene glycol that can compete economically. However, as mentioned previously, the chemical

route makes a mixture of isomers whereas the biological route makes a pure isomer. If chirality turns out to be important in an end use, then a bio-based process becomes much more attractive. Although there has been work on bio-based processes in academic labs, in contrast to PDO, no commercial activity is evident for a fermentation process for propylene glycol.

Research and Development

1,3-Propanediol

With the increasing potential of use of PDO in polymers, there has been an impetus to improve the yield and rates of the various PDO-producing strains. Various types of reactors and feeding strategies, the use of cosubstrates, and isolation of new organisms have all been approaches toward improvement of this fermentation based on glycerol. Also, metabolic engineering approaches have been used to widen the substrate range and to combine pathways of various microorganisms. The different approaches will be discussed in greater detail below.

A great deal of the focus has been on *Clostridium butyricum*, and the production of PDO from glycerol has been demonstrated at a scale of 2 m³ using the strain *C. butyricum* DSM 5431. In this work, air-lift and stirred tank reactors were compared, and no difference in product formation was seen. The effect of pH and temperature was also studied, and a temperature of 35 °C and a pH of 7.0 were selected as optimal. PDO (46–58 g/l) and productivities (2.3–2.9 g/l/h) were seen at both small and large volume (Gunzel et al. 1991).

A fed-batch strategy was used to avoid substrate inhibition. This system measured CO₂ produced, and the glycerol feed volume was calculated on the basis of a constant stoichiometry. Using strain VPI 3266 of *Clostridium butyricum*, batch and fed-batch fermentation processes were compared. Generally, the fed-batch results were about twofold better, with 65 g/l of PDO produced at a rate of 1.2 g/l/h and a PDO yield of 0.57. The fed-batch approach helps circumvent the organism's sensitivity to high initial concentrations of glycerol (Saint-Amans et al. 1994). Another important process feature is the composition of the medium. A low nutrient, or minimal, medium was devised for *C. butyricum*. Biotin was shown to be the sole growth factor required by this organism, and when biotin was present, the organism was able to produce 67 g/l of PDO from 129 g/l of glycerol, with a mixture of acetate and butyrate as by-products. Use of this media also provided evidence that nitrogen could be a limiting factor, especially when the carbon-to-nitrogen ratio was less than 81:1 (Himmi et al. 1999).

Continuous fermentations have also been used to improve PDO productivity. In a continuous *Klebsiella pneumoniae* fermentation, when glycerol was added in excess at an inlet substrate feed of approximately 74 g/l, PDO and various by-product acids were the major products. Under glycerol limitation (an inlet concentration of approximately 15 g/l), ethanol and hydrogen were the major products. The effect could be monitored by the evolution rates of hydrogen and CO₂. In glycerol excess, CO₂

evolution becomes higher than H₂ evolution, while it is the reverse in glycerol limitation (Solomon et al. 1994). Understanding the effects of various dilution rates on product distribution will help maximize the output of a PDO fermentation process.

Dilution rate was also shown to have an effect on PDO production by *K. pneumoniae*, with the highest PDO concentration achieved with a low dilution rate. This result differs from others mentioned below, and the authors state that in previous studies, the continuous cultures were run in a different fashion, with the substrate concentration in the feed constant, while the dilution rate was varied. In this study, the maximum experimental values seen were a PDO concentration of 35–48 g/l and a productivity of 4.9–8.8 g/l/h (Menzel et al. 1997).

In contrast, in a *Citrobacter freundii* fermentation, the highest PDO productivity was obtained under conditions of glycerol limitation at a high dilution rate. The highest values reported were 41.5 g/l of PDO produced from 80.5 g/l of glycerol, with an overall productivity of 1.38 g/l/h (Boenigk et al. 1993). Streekstra et al. (1987) also showed that a higher dilution rate improved productivity with *Klebsiella*.

There has also been some work on new reactor types in the production of PDO. Pflugmacher and Gottschalk (1994) used cells of *Citrobacter freundii* DSM 30040 immobilized on polyurethane carrier particles. In this case, the productivity increased with the dilution rate, and the maximum productivity was very high, at 8.2 g/l/h. A cell recycling system was tried with *Clostridium butyricum* using hollow fiber modules made from polysulfone. In this system, a productivity increase was seen; however, it could be achieved only in a narrow section of the theoretical range (Reimann et al. 1998b). The potential of new types of reactors and fermentation configurations still needs additional exploration before an optimal system is found for PDO production from glycerol.

Identifying new microorganisms with various desirable features for PDO production is another avenue that has been explored. Some desirable features for PDO production that would help to reduce fermentation operating costs include the ability to grow at higher temperature, the ability to grow on crude glycerol stocks, tolerance to high substrate and product concentrations, and the ability to produce PDO at a higher rate.

Various mud and soil samples were examined, and several glycerol-fermenting clostridia were isolated. The most active strain was able to convert up to 110 g/l of glycerol to 5 g/l of PDO in 29 h. In this strain, H₂ production was lower than expected, and reducing potential was transferred from ferredoxin to NAD, which increased PDO yields (Biebl et al. 1992). This strain, SH1, was renamed “DSM 5431” and was the parent strain used in further work to isolate more mutants with even more desirable characteristics.

Product tolerant mutants of *C. butyricum* DSM 5431 were isolated by Abbad-Andaloussi et al. (1995). Besides showing product tolerance, these mutants also yielded a higher biomass in fermentation. To further explore the use of these mutants, a fed-batch strategy was used which coupled the feeding of glycerol and ammonium to alkali consumption. A mixture of glycerol,

ammonium chloride, and sodium phosphate was fed when initial glycerol was nearly three quarters depleted. Using this feeding strategy, one of the mutants was able to reach a concentration of 70 g/l of PDO. The greatest increase, however, appeared to be in volumetric productivity, which more than doubled from 0.62–0.83 g/l/h to 1.4–2.4 g/l/h (Reimann and Biebl 1996).

The mutants of DSM 5431 showed other interesting properties. Under conditions of glycerol excess, the parent strain showed a significant decrease in substrate conversion, while the product tolerant mutants continued to consume glycerol and form product at a constant level. The key enzymes of PDO formation are higher in the mutant strains. With increased carbon flow, the wildtype, but not the mutants, showed increased levels of NADH and NAD⁺ and acetyl-CoA. The wildtype generated more reducing equivalents by producing more acetate and less butyrate (Reimann et al. 1998a).

One way by which cost can be addressed is by the use of lower-cost, cruder raw materials in fermentation. Ten new environmental *Clostridium* strains were isolated and identified as *C. butyricum*. Of these ten, four were able to ferment industrial glycerol, which was derived from transesterification of rapeseed oil, while *Clostridium* sp. obtained from culture collections could not. The best new isolate, named “E5,” was also more resistant to high levels of PDO. The new isolate was able to attain PDO yields on crude glycerol comparable to those of DSM 5431 on purified glycerol, reaching 58 g/l of PDO from 109 g/l of glycerol (Petitdemange et al. 1995). Another *Clostridium butyricum* isolate was also tested on industrial glycerol under a variety of conditions, including single-stage and two-stage fermentation. The maximum volumetric productivity was shown to be 5.5 g/l/h. The strain was also shown to be very tolerant of high PDO concentration, up to 80 g/l (Papanikolaou et al. 2000).

Another means of achieving process efficiency is by the use of thermophilic bacteria. With bacteria able to withstand high temperatures, hot effluents from fat cleavage plants can be used without cooling. It may also be possible to easily remove volatile by-products such as ethanol from the broth. A number of thermophilic producers of PDO from glycerol were isolated, and the most active strain, called “AT1,” was investigated further. Its pH optimum was 5.8–6.0 and temperature optimum was 58 °C. In batch fermentations, its productivity was much lower than that of mesophilic *Clostridium* and it appeared to be inhibited strongly by PDO and various by-products. This initial work showed promise, but further work needs to be done in improving this new strain or continuing to screen additional thermophilic strains (Wittlich et al. 2001).

The work described above has focused on the use of glycerol as the fermentation substrate. Several laboratories have also examined the use of cosubstrates by adding another hydrogen donor substrate to glycerol. Tong and Cameron (1992) used an *E. coli* with the *K. pneumoniae dha* genes and glycerol cofermented with either glucose or xylose. The best cell and PDO yield were obtained on glucose and glycerol. With glycerol alone, the PDO yield was 0.46 moles/mole compared to 0.63 moles/mole with glucose and glycerol. Lactate, formate, and

acetate were the primary by-products observed in most of the *E. coli* fermentations.

Three fermentable cosubstrates (glucose, 1,2-ethanediol, and 1,2-propanediol) were used in *C. butyricum* and *C. freundii* fermentations. Glucose was shown to enhance PDO yield in *C. butyricum* but not in *C. freundii*. On 1,3-ethanediol, the products were acetate and ethanol, and on 1,2-propanediol, the primary product was 2-propanol. The diols used electrons from glycerol that were oxidized to acids for an even hydrogen balance. Because approximately two times more glucose than glycerol is required to enhance yields, addition of glucose as a cosubstrate does not appear promising as an economic advantage in *C. butyricum* (Biebl and Marten 1995).

In yet another approach, cofermentations were carried out using mixed cultures of glycerol producers such as *Saccharomyces cerevisiae* grown together with glycerol utilizers such *C. freundii*, *K. pneumoniae*, and recombinant *E. coli*. PDO levels varied depending on the organisms used and the ratio of the organisms. PDO production was observed when various fermentable sugars were used, as well as during fed-batch production (Haynie and Wagner 1997).

Another very promising approach for improvement of biological PDO production is the use of metabolic engineering to create organisms with new capabilities. A number of different approaches have been tried with varying degrees of success. The genes of the *Klebsiella dha* regulon were introduced into *E. coli* by conjugation. *Escherichia coli* was able to then grow anaerobically on glycerol, but it did not produce PDO. This was most likely due to the lack of glycerol dehydratase (Sprenger et al. 1989). When the appropriate cofactor for glycerol dehydratase was supplied to *E. coli* containing the *Citrobacter freundii dha* regulon, it was able to produce PDO at relatively high amounts (Daniel and Gottschalk 1992).

Tong et al. (1991) detected production of PDO after transfer of the *dha* genes of *K. pneumoniae* into *E. coli*. The introduction of a new pathway into a microorganism is termed “metabolic engineering.” Taking this concept further, Skraly et al. (1998) constructed an operon of PDO genes that could be used in a number of hosts and where the regulation could be manipulated. The *dhaB* gene and the *dhaT* gene, which code for glycerol dehydratase and 1,3-propanediol oxidoreductase, respectively, were put under the control of a single promoter. The constructed operon also contained certain restriction sites that allow new promoters to be easily inserted. With the artificial operon, *E. coli* did produce PDO; however, the mix of products was different than previously reported.

The use of metabolic pathway engineering in *E. coli* may provide advantages over the natural producers. The tools to modify *E. coli* are readily available, the substrate range may be broadened, and genes can be added and subtracted to obtain optimal genes for the pathway (Cameron et al. 1993). This approach was also demonstrated in industrial laboratories and descriptions appear in the patent literature.

Raw materials, especially the carbon source, are a large portion of the cost of the PDO fermentation. As mentioned previously, the cost of glycerol can be fairly high, and a

lower-cost substrate such as glucose or even biomass-derived sugar is more attractive. This is the approach taken by DuPont and Genencor as evidenced by several patents. Glycerol or diol dehydratase was placed into microorganisms able to use various sugars, and the production of PDO from one microorganism using a sugar such as glucose was demonstrated (Laffend et al. 1997, 2000). The diol dehydratase enzyme that is responsible for the degradation of 1,2-propanediol and is part of the *K. pneumoniae pdu* operon was isolated and used. *Escherichia coli* transformants were able to use this enzyme to produce PDO from glycerol (Nagarajan and Nakamura 1998). A further improvement cited is to use a “protein X” gene, which consists of an open reading frame (ORF) coding for a protein responsible for in vivo activation of dehydratase activity. “Protein X” codes for a 51-KD polypeptide that was originally thought to be a subunit of the diol dehydratase activity. Host cells with this “protein X” and with the three known genes which encode subunits of diol dehydratase show increased PDO production (Diaz-Torres et al. 2000).

Another aspect of the DuPont and Genencor development was to transfer genes responsible for glycerol production into a host that did not naturally produce glycerol. The genes coding for the enzymes glycerol-3-phosphate dehydrogenase and glycerol-3-phosphatase were transformed into *E. coli*, and glycerol production was seen (Bulthuis et al. 1998).

The various approaches were combined into recombinant organisms that contained all the following genes: glycerol-3-phosphate dehydrogenase, glycerol-3-phosphatase, glycerol dehydratase, and 1,3-propanediol oxidoreductase. Microorganisms including *E. coli*, various *Klebsiella* species, and *Saccharomyces* were shown to produce PDO from glucose (Nakamura et al. 2000). The DuPont and Genencor effort has focused on *E. coli* because of the number of genetic tools available, and since *E. coli* does not naturally produce PDO, no natural regulation needs to be overcome. The constructed *E. coli* strain equals or exceeds glycerol-based natural organisms, with approximately 140 g/l of PDO produced from glucose in 45 h (Chotani et al. 2000).

1,2-Propanediol

The industrial focus on 1,3-propanediol has sparked interest in the microbial production of 1,2-propanediol. Some work has focused on the fermentation process of 1,2-propanediol as well as the metabolic engineering of pathways for its production. In early work with *C. thermosaccharolyticum*, various process conditions were examined such as temperature, pH, gas phase composition, and substrate concentration. This work was conducted in a volume of 2 l. The maximum cell concentration achieved was in the range of 1.0–1.3 g/l. The temperature range examined was 50–65 °C, and the optimal temperature for production was 60 °C. At higher temperatures, lactate decreased and ethanol increased. The pH range studied was from 6.0 to 7.2. At the optimal pH of 6.0, a concentration of 5.6 g/l of 1,2-PD was obtained. Other fermentation conditions were examined such as

the use of H₂ in the headspace as well as the use of yeast extract, which was shown to have an important effect on 1,2-PD production. The optimal fermentation conditions were defined as 45 g/l of glucose, 4.5 g/l of yeast extract, a pH of 6.0, a temperature of 60 °C, and the use of N₂ gas. Under these conditions, the final 1,2-PD concentration achieved was 9.05 g/l with a yield of 0.20 g/g of glucose (Sanchez-Riera et al. 1987).

The cost of production of 1,2-PD could be lowered by the use of low-cost, renewable sugars. D-Glucose, L-arabinose, and D-xylose are the major sugars from cellulosic biomass. Their use for 1,2-PD production was examined using *T. thermosaccharolyticum*. Also tested were L-galactose and lactose; lactose is of interest because it can be obtained at low cost from cheese whey (Altaras et al. 2001).

In earlier work, *T. thermosaccharolyticum* did not grow on lactose and D-galactose (Cameron and Cooney 1986). This organism was selected to grow on these sugars by multiple serial transfers. When tested in fermentations, these adapted organisms produced primarily ethanol and lactate, and no 1,2-PD was detected. The five-carbon sugars arabinose and xylose showed more promise, and both yielded 1,2-PD during fermentation. Arabinose was fermented at a rate and yield similar to glucose, while xylose fermentation was slower and the yield was approximately half. Whey permeate was shown to be a useful substrate for 1,2-PD production but only after hydrolysis of the lactose and supplementation with yeast extract (Altaras et al. 2001).

Another approach toward the improvement of 1,2-PD production is the use of metabolic engineering. *Escherichia coli* was chosen as the host organism because many tools are available for genetic modification. Although it does not produce 1,2-PD from glucose, it is able to produce the intermediate methylglyoxal (Cameron et al. 1998). *Escherichia coli* strains expressing rat lens aldolase produced 1,2-PD and acetol from glucose (Altaras and Cameron 1999).

Instead of rat lens aldolase, glycerol dehydrogenase from either *E. coli* or *K. pneumoniae* was overexpressed in *E. coli*. In this case, *E. coli* produced R-1,2-PD from glucose. The metabolic pathway probably involves the reduction of methylglyoxal to R-lactaldehyde by the glycerol dehydrogenase, and the R-1,2-PD is produced by reduction of R-lactaldehyde. The overexpression of *E. coli* methylglyoxal synthase alone causes *E. coli* to produce about the same amount of 1,2-PD as produced by the strains with overexpressed glycerol dehydrogenase. When both genes are overexpressed, the improvement in 1,2-PD production is even greater. Although the metabolic engineering of *E. coli* is promising, the maximum titer of 0.7 g/l of 1,2-PD is low (Altaras and Cameron 1999).

Further improvements were made by a series of metabolic engineering strategies. Activities of enzymes leading to the production of the by-product, lactate, were abolished. A complete 1,2-PD pathway comprising glycerol dehydrogenase (*gldA*), methylglyoxal synthase (*mgs*), and 1,2-PD oxidoreductase (*fucO*) was put in the lactate minus background. The use of alcohol dehydrogenase in place of 1,2-PD oxidoreductase was also evaluated, but the use of 1,2-PD oxidoreductase ultimately gave better results. Using a fed-batch fermentation, *E. coli*

Table 2.5

Patents/patent applications for 1,3-propanediol and 1,2-propanediol production in the bioprocess area

Assignee	Patent number	Year	Technology
Unilever	US patent 5,164,309	1992	Production of PDO from glycerol by <i>Citrobacter</i>
Henkel Kommanditgesellschaft auf Aktien, Gesellschaft für Biotechnologische Forschung mbH	US patent 5,254,467	1993	Production of PDO from glycerol
DuPont	US patent 5,686,276	1997	Production of PDO from a fermentable carbon source using a single microorganism
DuPont	US patent 5,599,689	1997	Use of mixed microbial cultures to produce PDO
DuPont	US patent 5,821,092	1998	Production of PDO from glycerol with a recombinant bacteria expressing diol dehydratase
DuPont and Genencor	US patent 6,025,184	2000	Production of PDO from a fermentable carbon source by a microorganism containing a glycerol or diol dehydratase
DuPont and Genencor	US patent 6,013,494	2000	Recombinant organisms for PDO production containing a variety of genes
Genencor	US patent 6,136,576	2000	Use of recombinant microorganisms for PDO production
Genencor	PCT WO 00/70057	2000	Mutant 1,3-propanediol dehydrogenase
DuPont	PCT WO 01/12833	2001	Production of PDO from a fermentable carbon source in a single organism
Institut National de la Recherche Agronomique, Institut National des Sciences Appliquees de Toulouse, Centre National de la Recherche Scientifique	PCT WO 01/04324	2001	Production of PDO in the absence of coenzyme B12 or its precursors
DuPont	PCT WO 01/11070	2001	Isotopic fingerprinting of PDO produced from a fermentable carbon source
Wisconsin Alumni Research Foundation	US patent 6,087,140	2000	Microbial production of 1,2-propanediol from sugar

Abbreviations: US United States; PDO 1,3-propanediol; PCT Patent Cooperation Treaty; and PCT WO international patent

lacking lactate dehydrogenase and containing *gldA*, *mgs*, and *fucO* genes gave the highest titers of 4.5 g/l with a yield of 0.19 g of 1,2-PD per gram of glucose consumed (Altaras and Cameron 1999). As *E. coli* is tolerant to over 100 g/l of 1,2-PD (Cameron et al. 2000) and can be improved significantly by metabolic engineering, the potential for improving a process employing recombinant *E. coli* strains is significant.

Patents and Regulatory Issues

In the production of monomers such as PDO and 1,2-PD, there are many patents that cover the chemistry and process of synthesizing these chemicals. The separation of these chemicals from the synthetic mix is another important area of technology (Malinowski 1999, 2000). There is patent activity, especially on the various new technologies for the chemical synthesis of PDO that have lowered the cost of the monomer and opened it for more widespread application. There are also undoubtedly numerous patents on the formulation of the various polymers that contain PDO and 1,2-PD and the applications and end use

of these chemicals. It is beyond the scope of this review to cover the chemical process and application patents for PDO and 1,2-PD, inasmuch as a search of the United States Patent Database using the key word “propylene glycol” turns up more than 1,000 patents!

In PDO production by biological processes, the number of patents is fairly small, with the greatest patent activity occurring in the past 5 years. The patent activity for biological production of 1,2-PD is even less and will be summarized with the PDO patents. Although patents have been referenced where appropriate in the text, a summary of some of the patents on biological production is listed (▶ Table 2.5).

Prospects for Production of 1,3-Propanediol and 1,2-Propanediol by a Bioprocess

There are many issues to be addressed in the production of any intermediate for the chemical industry with the use of a microbial process. Often the raw material is a chief cost component, so the microorganism must be able to use low-cost

substrates such as glucose derived from corn processing or other sugars that may be derived from the processing of low-cost biomass. The yield of the product on the substrate as well as the ability to reach a fairly high product concentration is also important. Also, the by-products produced by the microorganism are important as they both impact yield as well as the design of the separation process.

Activity in designing new PDO processes using both a chemical route and a biological one has been considerable. Quite often, large-volume chemicals are made by more than one chemical process, so it is possible that in the future, PDO may be made by more than one process, with one being a competitive, economic biological one. The advances in recombinant DNA technology and the ability to create microorganisms with new pathways will help drive the production of industrial chemicals by biological means.

The possibility of future production of PDO by a biological process appears bright. By combining pathways of more than one organism into *E. coli*, DuPont and Genencor report a microorganism that can produce around 140 g/l of PDO from glucose in less than 50 h (Chotani et al. 2000). The availability of tools for genetically manipulating *E. coli* suggests that further improvements are likely to be made. Other challenges that remain will be the separation of PDO from broth and the purification of PDO such that it can be used in fiber production.

The near-term prospects for production of 1,2-PD via a biological process do not seem likely. A biological process must compete with well-known large-scale chemical processes using low-cost raw materials. The titers of 1,2-PD are still low; however, the use of host organisms such as *E. coli* may provide some opportunity to increase levels. An interest in bioprocess development may be sparked if a market or product opportunity can be identified for the racemically pure product produced by microorganisms (Cameron et al. 1998).

In the future, the economics of production of chemicals by biological processes may become more attractive with dwindling supplies and higher prices of oil. A bioprocess can also provide opportunities for the agricultural sector in the use of renewable resources such as corn. At some point, public interest in the use of renewable resources may also drive further development of these diols as well as other chemical products.

2,3-Butanediol Production

Introduction

A colorless odorless liquid, 2,3-butanediol (2,3-BD), is also called “2,3-butylene glycol,” “dimethylethylene glycol,” or “2,3-dihydroxybutane.” It can be produced by a number of microorganisms in the genera *Serratia*, *Pseudomonas*, *Bacillus*, and *Klebsiella*, but most investigators have focused on *Klebsiella pneumoniae* (also known as “*Klebsiella oxytoca*”) and *Bacillus polymyxa*, which is now known as “*Paenibacillus polymyxa*” (Nakashimada et al. 2000). Reviews have covered the history,

uses, and technical developments in this field (Afschar et al. 1993; Garg and Jain 1995; Syu 2001). The fermentation was described in the early part of the twentieth century, but the height of interest came during wartime, as 2,3-BD can be converted to 1,3-butadiene, which is used in synthetic rubber (Syu 2001).

Production of 2,3-BD is via a mixed acid fermentation pathway that also leads to a mix of acetate, lactate, formate, succinate, and ethanol. Juni and Heym (1956) proposed that 2,3-BD is produced in bacteria from pyruvate through the intermediates α -acetolactate and acetoin. Also, microorganisms can degrade 2,3-BD (i.e., it is biodegradable), a feature that may add to its attractiveness as an industrial chemical.

2,3-BD has three stereoisomers: *dextro*- and *levo*-forms that are optically active and an optically inactive *meso*-form. Different microorganisms produce different stereoisomers, but generally a mixture of two is formed (Syu 2001). Although stereoisomer formation has been studied and a new mechanism proposed (Ui et al. 1998), in much of the 2,3-BD-related work, stereoisomer formation is not measured.

Much of the focus of 2,3-BD work has been on the fermentation, and high productivities and high 2,3-BD concentration in fermentors have been achieved. Concentrations of 102.9 g/l of butanediol and acetoin were achieved in 32 h with *Enterobacter aerogenes* (Zeng et al. 1994a) and 113 g/l of these combined products were achieved from *Klebsiella pneumoniae* (Yu and Saddler 1983). Bioconversion yields of 0.45 g/g of glucose were also observed (Sablayrolles and Goma 1984). The application of molecular biology and strain improvement may help to improve the fermentation process, although surprisingly little has been reported. The genes of the 2,3-BD operons were cloned from *Klebsiella terrigena* and *Enterobacter aerogenes* and characterized (Blomqvist et al. 1993). Reports describe the cloning of the gene responsible for the formation of *meso*-2,3-BD, which opens up the avenue of a strain producing a pure isomer (Ui et al. 1996, 1998).

The economics of the fermentation may be helped by the fact that the best 2,3-BD producers are able to grow and make product on a variety of sugars. The use of various low-cost materials such as whey and hydrolyzed biomass has been investigated and shows promise for future use and will be discussed in more detail later (Yu et al. 1982; Laube et al. 1984; Lee and Maddox 1986; Champluvier et al. 1989).

The primary economic barrier to commercialization may not be the fermentation but rather the separation of 2,3-BD from the media. It does not separate well by distillation, and chemical conversion of 2,3-BD in the broth and subsequent distillation are costly (Afschar et al. 1993). Other separation techniques that have been examined include salting out (Afschar et al. 1993) and countercurrent steam stripping (Garg and Jain 1995). Continued fermentation and downstream improvements and a change in the economics of petrochemicals may at some future date make 2,3-BD production from a bioprocess economically attractive.

Scientific Background

2,3-Butanediol is produced via a mixed acid pathway with a variety of end products. By this pathway, the organism can make a less inhibitory neutral compound such as 2,3-BD in place of acid production (Johansen et al. 1975). *Bacillus polymyxa* catalyzes a number of biosynthetic reactions which the cell balances for energy and growth. The following reactions as described by de Mas et al. (1988) are included to illustrate the variety of end-products in parallel pathways:

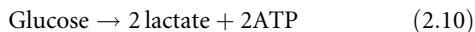
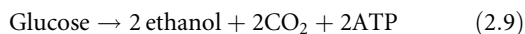
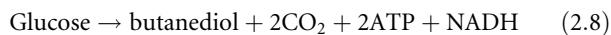
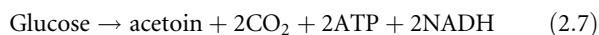
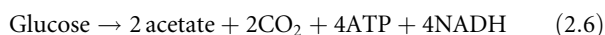

Reduced nicotinamide adenine dinucleotide (NADH) can be used to generate ATP through the electron transport system. The balance of the reactions and end products in the cell is affected by the oxygen availability and the oxygen uptake rate (de Mas et al. 1988). Considerable effort has been spent on oxygen transfer and oxygen uptake in improving the fermentation. This topic will be discussed in more detail in the section **Research and Development** in this chapter.

Juni and Heym (1956) described a cyclic pathway for the dissimilation of 2,3-butanediol. A number of microorganisms oxidize 2,3-BD to acetic acid. The pathway from Juni and Heym is shown in the following figure modified by Syu (2001). The three stereoisomeric forms of 2,3-BD are (1) D(–) or R,R; (2) L(+) or S,S; and (3) *meso* or R,S.

Three enzymes are involved in the synthesis of 2,3-BD: α -acetolactate synthase (EC 4.1.3.18), α -acetolactate decarboxylase (EC 4.1.1.5), and butanediol dehydrogenase (also known as diacetyl [acetoin] reductase; Larsen and Stormer 1973; Johansen et al. 1975; Stormer 1975). Two different enzymes form acetolactate from pyruvate. The first, termed “catabolic α -acetolactate synthase,” has a pH optimum of 5.8 in acetate and is part of the butanediol pathway. The other enzyme, termed “anabolic α -acetolactate synthase” or “acetohydroxyacid synthetase,” has been well studied and characterized and will not be discussed here. This enzyme is part of the biosynthetic pathway for isoleucine, leucine, and valine and is coded for by the *ilvBN*, *ilvGM*, and *ilvH* genes in *E. coli* and *Salmonella typhimurium* (Bryn and Stormer 1976).

The second enzyme in the butanediol pathway is acetolactate decarboxylase, which has a pH optimum of about 6.3 and which catalyzes the decarboxylation of acetolactate to acetoin. The third enzyme, diacetyl (acetoin) reductase, catalyzes a reversible reduction of acetoin to 2,3-BD and an irreversible

reduction of diacetyl to acetoin. It is a tetrameric enzyme and requires NADH (Larsen and Stormer 1973).

In *Klebsiella terrigena* and *Bacillus subtilis*, this enzyme is found within the acetoin cluster of genes. Interestingly, in *Lactobacillus lactis*, this gene is found within the gene cluster that encodes the enzymes of branched chain amino acid synthesis. This enzyme has different kinetic properties than the enzymes of *K. terrigena* and *B. subtilis* and may play a key role in acetolactate flux in *L. lactis* (Goupil-Feuillerat et al. 1997).

Acetate induces the three enzymes and activates acetolactate synthase. In a study comparing wildtype *Enterobacter aerogenes* and mutants deficient in 2,3-BD and acetoin production, during the highest phase of 2,3-BD production, the three enzymes of the pathway constituted approximately 2.5 % of the protein in the cell. Butanediol production also appears to play a role in regulating the NADH/NAD ratio (Johansen et al. 1975).

Different mechanisms have been proposed for the formation of the various stereoisomers of 2,3-BD. Some of the initial difficulty was in obtaining a pure stereoisomer for study. A fermentation route to synthesis of pure *meso*-isomer was demonstrated in *Serratia. Bacillus polymyxa* was used to prepare the D(–)-isomer, and *Bacillus cereus* was used to make L(+)-isomer. Conditions such as pH, temperature, and shaking were modified to optimize production of the various isomers (Ui et al. 1983).

One of initial models for stereoisomer formation was postulated by Taylor and Juni (1960) for *K. pneumoniae*. They proposed the existence of an acetoin racemase, L(+) 2,3-BD dehydrogenase and D(–) 2,3-BD dehydrogenase. The L(+) 2,3-BD dehydrogenase would convert L(+) acetoin to L(+) 2,3-BD and *meso*-2,3-BD, whereas the D(–) 2,3-BD dehydrogenase would reduce D(–) acetoin to D(–) 2,3-BD and *meso*-2,3-BD.

A newer model for *K. pneumoniae* was similar to the earlier one in that it included an acetoin racemase. However, in this newer model, D(–) acetoin is converted to *meso*-2,3-BD, and L(+) acetoin is converted to L(+) 2,3-BD. This model is based on the purification and separation of the two acetoin reductases and the determination of their stereospecificity (Voloach et al. 1983) (► Fig. 2.6).

A novel mechanism for stereoisomer formation was described for *Bacillus polymyxa*. The RR-acetoin formed from pyruvate is converted into RR-butane-2,3-diol by diacetyl (acetoin) reductase. The same enzyme reduces diacetyl to RR-acetoin. An S-acetoin-forming diacetyl reductase converts diacetyl to SS-acetoin. The racemic acetoin molecules are acted upon by a butane-2,3-diol dehydrogenase, which generates either RR-butane-2,3-diol or *meso*-butane-2,3-diol (Ui et al. 1986).

Bacillus cereus was shown to have the enzymes of the butane-2,3-diol cycle. Acetylacetoin was reduced to two new stereoisomers of acetylbutane-2,3-diol by two separate acetylacetoin reductase enzymes. These isomers were subsequently converted by acetylbutane-2,3-diol hydrolase to RR- and *meso*-2,3-BD (Ui et al. 1998). Clearly, the production of the various stereoisomers is a complex issue that will require additional study and the purification of the various enzymes.

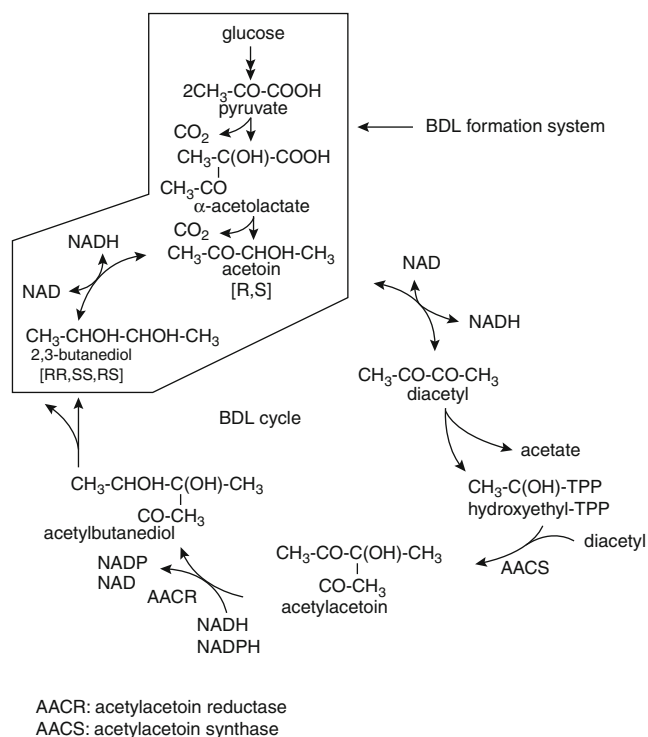

■ Fig. 2.6

The 2,3-butanediol cycle in bacteria, as proposed by Juni and Heym (1956). The boxed area represents 2,3-BD formation in bacteria. BDL butanediol; TPP thiamine pyrophosphate; AACs acetylacetoin synthase; AACR acetylacetoin reductase; NAD nicotinamide adenine dinucleotide; NADH reduced nicotinamide adenine dinucleotide; NADP nicotinamide adenine dinucleotide phosphate; NADPH reduced nicotinamide adenine dinucleotide phosphate (Redrawn from Syu (2001), with permission)

The production of 2,3-BD by microorganisms requires the balancing of a number of fermentation reactions in the cell. Mathematical models can be very useful to explain the interrelation of equations, and these models need to be verified by experimental data. Various models have been described, and the reader is referred to Papoutsakis and Meyer (1985).

The acid end products of fermentation can inhibit growth and butanediol formation. Large quantities of butanediol, up to 130 g/l, were not strongly inhibitory, while 0.45 g/l of acetic acid can completely inhibit growth of *K. oxytoca*. Butanediol inhibition is believed to be due to the reduction of water activity, while acetic acid and not its salt is the inhibitory metabolite (Fond et al. 1985). In *Enterobacter aerogenes*, ethanol was also shown to be an inhibitory metabolite for growth (Zeng and Deckwer 1991).

Klebsiella pneumoniae and other 2,3-BD-producing microorganisms are able to use a variety of five- and six-carbon sugars to produce 2,3-BD. Pentoses are metabolized through a common intermediate, D-xylulose-5-phosphate. In *K. pneumoniae*, 3 moles of pentose are converted to 5 moles of D-glyceraldehyde-3-phosphate, which is an equivalent yield of D-glucose through glycolysis (Jansen and Tsao 1983). The conversion of

pentoses and pentitols is shown in Fig. 2.7, as described by Jansen and Tsao (1983).

There have been a number of fermentation studies on 2,3-BD formation. One of the most crucial factors identified is the amount and timing of oxygen supplied. A higher oxygen transfer coefficient favors the production of biomass while inhibiting butanediol production in *Aerobacter aerogenes*. Oxygen suppresses the production of ethanol, but some butanediol can be produced in the presence of oxygen. The maximum oxygen transfer coefficient (Kla) was found to be in the range of 50–100 h⁻¹ (Sablayrolles and Goma 1984).

Various control strategies for oxygen have been tried to maximize butanediol production. In one study, oxygen transfer rate (OTR) was used to maintain growth rate and specific oxygen uptake rate. When a set oxygen transfer rate was maintained that kept the culture at a constant level of oxygen limitation, the final butanediol concentration was similar to an experiment where OTR was uncontrolled. The improvement in the OTR-controlled fermentation was in the rate of 2,3-BD formation, as the productivity or rate of formation of 2,3-BD was 18 % higher (Beronio and Tsao 1993).

Control of microaerobic fermentations by oxygen transfer rate has limitations, as the distribution of oxygen may differ in various types and sizes of reactors. In a somewhat different approach, control by respiratory quotient was attempted. Optimum 2,3-BD production was seen at a respiratory quotient between 4.0 and 4.5, and product concentration (butanediol and acetoin) greater than 100 g/l was measured. This was compared to a control fermentation where an oxygen transfer rate of 35 mmol/l/h was maintained. In this case, the respiratory quotient eventually decreased to about 1.5 and product formation was only about 85 g/l. Biomass in the fermentation with respiratory quotient control was higher than in the OTR-controlled fermentation (Zeng et al. 1994a).

Continuous culture can also be used to determine the optimum oxygen supply. In one system using *K. pneumoniae*, with an inlet feed glucose concentration of 100 g/l, the optimum oxygen transfer rate (defined as when maximum product was formed) was determined to be 25.0–35.0 mmol/l/h. Increasing the oxygen input and thus the OTR reduced the product yield (Ramachandran and Goma 1988).

In another continuous culture study, maximum oxygen uptake rates (OUR) were determined and they differed depending on the dilution rate. By varying the speed of the impeller with constant aeration, different OURs could be obtained. As dilution rate increased, the yield and product concentration decreased. Product formation was not dependent on growth rate, and even at low or no growth rates, higher specific productivity can be expected. At low OURs, the cells use fermentation for growth and maintenance and continue to convert substrate to 2,3-BD. The authors suggest that a cell recycling or cell immobilization system is a strategy used to take advantage of the potential productivity of nongrowing cells (Zeng et al. 1990).

There is some evidence that the availability of oxygen can also affect the optical purity of 2,3-BD isomers produced. In a

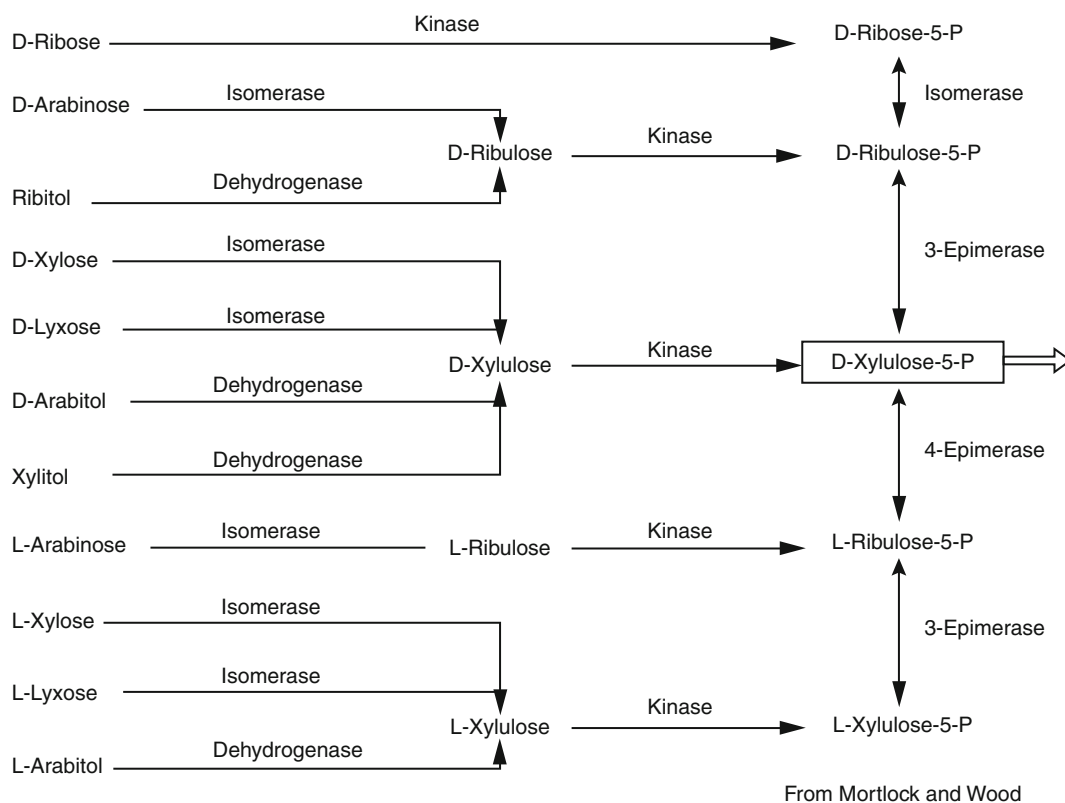

Fig. 2.7

Conversion of pentoses and pentitols (From Jansen and Tsao (1983), with permission)

continuous culture system with *Paenibacillus polymyxa*, when airflow was increased, the optical purity of 2,3-BD decreased (Nakashimada et al. 1998). Certainly, control of oxygen is a critical parameter in the 2,3-BD fermentation process.

Commercial Applications

At present, 2,3-BD is sold as a commercial chemical intermediate. Interest in its production by fermentation peaked during World War II because 1,3-butanediene needed for synthetic rubber production could be made from 2,3-BD. With the rise of the petroleum industry and increase in the availability of cheap raw materials, industrial fermentations for 2,3-BD were no longer of commercial interest (Rosenberg 1980).

In one method of production via petrochemical means, *n*-butenes can be separated by distillation from hydrocarbons. Treatment with hydrogen peroxide converts butanes such as 1-butene or 2-butene to their epoxide. A glycol such as 2,3-BD is then derived from the epoxide of 2-butene (Szmant 1989).

The boiling and freezing points of 2,3-BD are 180–184 °C and –60 °C, respectively. It is either a colorless liquid or in crystalline form. It can be dehydrogenated to diacetyl, a highly valued flavoring agent in food products (Syu 2001). It can also be dehydrated to methyl ethyl ketone, which has uses as a liquid fuel additive and a solvent. The levo-form of 2,3-BD has potential use

in antifreeze. Butanediol can be esterified and, in this form, could be used as a precursor for drugs and cosmetics. Other potential industrial applications include inks, plasticizers, and moistening agents (Garg and Jain 1995). One of the attractive features of butanediol is its biodegradability. Number microorganisms are able to consume it at high rates. This makes it an environmentally friendly product (Afschar et al. 1993).

Butadiene appears to be the key intermediate for further conversion and other potential new uses of 2,3-BD. Butadiene can be dimerized to styrene, a large-volume chemical intermediate for the polymer industry (Jansen and Tsao 1983). Styrene is an eight-carbon molecule with an aromatic ring. Conversion of 2,3-BD to butadiene is not economically attractive. The butadiene market demand has dropped significantly, as its major styrene polymer end markets, automobile parts and construction, are also down sharply. Although the price of butadiene is presently in the range of \$US0.20 per pound, future improvement in the economy is expected to increase demand for butadiene and possibly the price (Hoffman 2001).

At the low selling price of butadiene, it is difficult to see how biologically produced material could be made cost competitive. Perhaps the greatest potential for 2,3-BD may lie in higher-value specialty product uses in such industries as chemical, pharmaceutical, and personal care. Better understanding of the market opportunity is necessary as well as further development of the various 2,3-BD chemical conversion processes.

Research and Development

There have been a number of fermentation studies for the production of 2,3-butanediol. From a process standpoint, it is not easy to make a direct comparison between the various studies because, often, types of fermentors and combinations of process conditions were different. One major focus has been the use of biomass and biomass-derived sugars for the production of 2,3-BD. There is good indication that with the proper conditions, large quantities of 2,3-BD can be made from low-cost or waste sugars.

It is possible to use high concentrations of glucose in *E. aerogenes* NRRL B199 fermentations and achieve good yields. At a glucose concentration of 195 g/l, the yield of 2,3-BD was 0.45 g/g. However, there was some growth inhibition with such initial high substrate concentrations. At the high substrate concentration, only 2.4 g/l of ethanol was produced. The productivity was over 1 g/l/h, making this an attractive process (Sablayrolles and Goma 1984). When a fed-batch approach was used with *K. pneumoniae* to overcome initial inhibitory sugar concentrations, up to 88 and 113 g of butanediol and acetyl methyl carbinol could be produced from 190 g of xylose and 226 g of glucose, respectively (Yu and Saddler 1983).

It is not surprising that various process conditions such as pH will also have an effect on fermentation. Biomass concentrations of *E. aerogenes* were shown to increase between pH of 5 and 7, while 2,3-BD production was optimum between pH 5.5 and 6.5 and dropped off at a higher pH (Zeng et al. 1990). *Paenibacillus polymyxa* also showed a pH optimum for production of 2,3-BD between 5.7 and 6.3 in a chemostat system (Nakashimada et al. 1998).

The effect of added acetic acid also changed with pH. At pH of 5.5, less than 1 g/l of acetic acid inhibited product formation, whereas at a culture pH of 6.7, it took roughly ten times more acetic acid to show the same effect. This inhibitory effect is due to the undissociated form of acetic acid (Zeng et al. 1990).

With *K. pneumoniae*, acetic acid was shown to stimulate 2,3-BD production up to two- to threefold when added at concentrations less than 1 %. This media was at a pH of 6.5 and contained glucose, xylose, and various nutrients. The stimulation by acetic acid may be due to activation of the 2,3-BD pathway enzymes. Yeast extract, urea, ammonium sulfate, and trace elements were also shown to improve yields in this system (Yu and Saddler 1982). A variety of acids were found to enhance 2,3-BD production in *P. polymyxa*: acetate, propionate, pyruvate, and succinate showed an effect, while *n*- and *iso*-valerate, *n*- and *iso*-butyrate, formate, malate, and lactate had no effect. Acetic acid was the best and also did not reduce the optical purity of the 2,3-BD; thus a feeding strategy with acetic acid may show promise for this organism (Nakashimada et al. 2000).

The use of low-cost biomass sources as a substrate for 2,3-BD production has received considerable attention as a way to improve the economics of the process. The main components of woody biomass are lignin, cellulose, and hemicellulose. Cellulose is a polymer of D-glucose, while

hemicellulose is a polymer containing mostly the five-carbon sugars, D-xylose, L-arabinose, and D-ribose (Rosenberg 1980).

Klebsiella is a versatile organism and is able to utilize many sugars for growth and 2,3-BD production. In one study where xylose was evaluated, maximum cell growth occurred at a sugar concentration of 20 g/l (Jansen and Tsao 1983). The stoichiometry of the conversion of pentoses is equivalent to that of the conversion of hexoses. As seen with glucose fermentations, there is a growth phase in fermentors with xylose, and when oxygen becomes limiting, then 2,3-BD production is seen. In media with 100 g/l of xylose, the pH optimum for growth is 5.2, but growth drops off sharply at pH lower than 5.2. A xylose concentration of 20 g/l is optimum for growth, as higher sugar concentrations lower the water activity. Oxygen supply is critical, and variations in oxygen supply can change the yields of the various products produced by *Klebsiella*. The best 2,3-BD production rate was shown to occur at an oxygen transfer rate of 0.027 moles/l/h. With an initial xylose concentration of 100 g/l, the average butanediol production rate was 1.35 g/l/h (Jansen et al. 1984). Added succinate at 10 g/l was shown to improve 2,3-BD productivity from xylose, while higher concentrations of succinate were inhibitory (Eiteman and Miller 1995).

Pretreated cellulosic materials have been tested with *Klebsiella* for butanediol production with some success. *Klebsiella* was grown on acid-hydrolyzed wood hemicellulose, and 2,3-BD yields of 0.4–0.5 g/g were obtained. The authors proposed that such high yields were partially due to the ability of *Klebsiella* to simultaneously ferment uronic acids, such as D-glucuronic and D-galacturonic acid, present in the wood samples. Other compounds in wood (such as furfural and lignin derivatives) are inhibitory to the bacteria if the wood hydrolysate is added at too high a concentration (Yu et al. 1982). A study comparing the effects of a number of inhibitors on *Klebsiella* was reported. Sulfate and furfural up to concentrations of 0.2 % w/v reduced 2,3-BD yield, and phenolic compounds inhibited bacterial growth (Frazer and McCaskey 1991).

A more efficient approach to use of woody biomass was simultaneous saccharification and fermentation (SSF) for 2,3-BD production. Culture filtrates of *Trichoderma harzianum* were added as a source of hydrolytic enzymes. SSF can shorten overall process times and relieve end product inhibition. The mixture of sugars derived from both cellulose and hemicellulose can be used for 2,3-BD production, thus eliminating the costs of separating the sugars (Yu and Saddler 1985).

Klebsiella was grown on woody biomass in coculture with *T. harzianum*. The fungal growth medium was found to inhibit the growth of *Klebsiella*, therefore, resting cells of *Klebsiella* were used. Both the hemicellulose and cellulose sugar streams were used for 2,3-BD production, and yields of approximately 30 % of theoretical were obtained (Yu et al. 1985).

Another potential low-cost substrate is cheese whey. Using *K. pneumoniae* cells immobilized in calcium alginate, a productivity of 2.3 g/l/h on whey permeate was demonstrated. The system was stable during 7 weeks of continuous operation (Lee and Maddox 1986). In another study, *K. oxytoca* was shown

to grow poorly on lactose, but it grew very well on the component sugars, glucose and galactose. The aeration rates affected growth on lactose; low aeration results in a lower cell growth rate. One possible factor for the lower growth rate on lactose may have been inefficient transport into the cell (Champluvier et al. 1989).

Molasses appears to have potential value as a substrate for 2,3-BD production. *Klebsiella oxytoca* can ferment molasses at high concentrations. In one batch experiment, as much as 280 g/l of molasses was converted to 118 g/l of 2,3-BD and 2.3 g/l of acetoin. These high concentrations are needed inasmuch as molasses is a relatively expensive substrate, and the separation costs of the final product may be difficult from such a complex carbohydrate source (Afschar et al. 1991).

Various new process concepts have been proposed for 2,3-BD production. The prospect of making both 1,3-propanediol and 2,3-BD in the same fermentation was proposed using *K. pneumoniae* and glycerol as a substrate. In continuous culture, if the pH was lowered stepwise, 2,3-BD formation started at pH 6.6. This fermentation has the potential to be economically attractive as few by-products are formed (Biebl et al. 1998).

New process methods have been investigated for 2,3-BD production. An improvement of productivity over a continuous or batch system was observed in a cell recycle system using *Klebsiella*. One drawback occurred when biomass built up past a certain level; at this point, the coefficient of mass transfer for oxygen decreased and the viscosity increased owing to microbial polysaccharide production (Ramachandran and Goma 1988). A novel process technology that improved the use of lactose was employed using coimmobilized cells of *Kluyveromyces lactis* with *Klebsiella oxytoca*. The yeast cells were permeabilized with solvent and used as a source of lactase. The rate of production on lactose was similar to that of immobilized cells on glucose (Champluvier et al. 1989).

Other microorganisms have been studied for their potential in 2,3-BD production. Certain strains of *B. polymyxa* were shown to be 2,3-BD producers from xylose. Yeast extract improved yields, which reached 16 g/l (Laube et al. 1984). In the process of searching for an organism that could produce ethanol from arabinose, an *Enterobacter cloacae* was isolated that could produce 2,3-BD from arabinose, with yields as high as 0.4 g/g of arabinose. Besides the pure sugar, the organism could use sugars from acid- and enzyme-hydrolyzed corn fiber. The organism prefers arabinose but will also use glucose and xylose. This organism opens up the opportunity to produce 2,3-BD from a corn fiber feedstock (Saha and Bothast 1999).

Various *Bacillus* have been studied for 2,3-BD production. Much of the focus has been on *Bacillus polymyxa*, as besides *Klebsiella*, it is considered to have industrial potential. It produces primarily pure L-isomer. A number of isolates of *B. polymyxa* were checked on media that contained xylan. One strain especially, *B. polymyxa* NRCC 9035, produced a considerable amount of diol on xylose. Yeast extract appeared to have a beneficial effect on the xylose fermentation, and diol concentrations of 4.2 g/l were seen. *Bacillus polymyxa* also

fermented other sugars in hemicellulose, including mannose, galactose, and L-arabinose (Laube et al. 1984).

Bacillus amyloliquefaciens may be a promising organism for 2,3-BD production as its major products of fermentation are 2,3-BD and some minor acids. It is able to use a variety of sugars, but the best productivity and yield are on glucose. As observed in other 2,3-BD fermentations, aeration plays a critical role, with high aeration favoring biomass formation and lower aeration favoring 2,3-BD production. With this organism, approximately 33 g of diol was formed from 100 g of sugar (Alam et al. 1990).

One of the highest 2,3-BD yields was reported from *Bacillus licheniformis*. The theoretical yield of 2,3-BD from glucose is 0.5 g/g of glucose. *Bacillus licheniformis* was able to reach 94 % of the theoretical yield in 72 h. The best yields were obtained when peptone and beef extract were added to the medium. This productivity was similar to that of *Klebsiella* and *Bacillus polymyxa* (Nilegaonkar et al. 1992). Additional work to characterize *B. licheniformis* strains was done by using profiles of the fermentation products formed. A number of *B. licheniformis* strains were compared with *B. polymyxa* strains. The product profiles for the *B. licheniformis* strains were similar to each other; however, they differed from the *B. polymyxa* strains. Protein electrophoretic patterns were also used to classify the strains. Again, with protein electrophoretic patterns, *B. licheniformis* was mapped in a different cluster than *B. polymyxa*. In fermentation tests, some of the *B. licheniformis* strains were shown to be as promising as *B. polymyxa* for 2,3-BD production (Raspoet et al. 1991).

Very little appears in the literature on any genetic engineering of the 2,3-BD pathway. The 2,3-BD operon from *Klebsiella terrigena* and *Enterobacter aerogenes* was cloned and characterized. The genes coding for α -acetolactate decarboxylase, α -acetolactate synthase, and acetoin (diacetyl) reductase were shown to be clustered in one operon. The genes were sequenced and called "budABC." The budABC operon appears to be regulated at the transcriptional level, as the highest amount of transcript was seen under conditions that favored 2,3-BD production. A putative fumarate nitrate reduction regulatory protein (FNR) site was found at position -6. The FNR protein can activate genes at the level of transcription that are involved in anaerobic processes. The cloning of the budABC operon will facilitate the study of gene regulation and improvement of the 2,3-BD process (Blomqvist et al. 1993).

A gene fragment from *K. pneumoniae* IAM1063 that contains the meso-2,3-butanediol dehydrogenase was cloned and transformed into *E. coli*. This transformed *E. coli* produced only meso-2,3-BD from racemic acetoin (Ui et al. 1996). Using sequence homology from the *Klebsiella terrigena* operon, the meso-2,3-butanediol dehydrogenase and the remainder of the 2,3-BD-forming operon were cloned into *E. coli*. *Escherichia coli* was shown to produce meso-2,3-BD from glucose with no contamination of the L-form. The *E. coli* was tested in shake flasks, and the highest productivity was with a starting glucose concentration of 100 g/l, which yielded 17.7 g/l of meso-2,3-BD (Ui et al. 1997). Clearly, this work is promising, and applying techniques of molecular biology and metabolic engineering may further improve the productivity of the 2,3-BD fermentation.

Patents and Regulatory Issues

Few patents in the United States patent literature can be found that deal with 2,3-BD production via a microbial process. With commercialization efforts, one would expect to find patents that cover the microorganisms involved, genetic manipulations, fermentation process improvements, and downstream separation of the product from broth. This may indicate that a bioprocess has not yet attracted the interest of industry.

Prospects

The study of the formation of 2,3-butanediol by bacteria has spanned quite a number of years. Early work included the elucidation of the pathway and some of the basic biochemistry of the enzymes. More recently, much of the research has focused on the fermentation process and understanding the parameters that would lead to a fermentation of high yield and productivity.

As raw materials are likely a large part of the fermentation production cost of 2,3-BD, the variety of work with biomass shows promise in helping to reduce the costs of the fermentation. The cloning of the 2,3-BD genes will help open up opportunities for improving the host organism using techniques of metabolic engineering. One of the major challenges to the economics of this process will be the development of an efficient and cheap downstream process for separation of the material from fermentation broth.

As with any chemical intermediate that can be made by a biological process, several key challenges will remain. First, there must be a sufficient market demand to drive the research and development costs. Secondly, the cost of competing petrochemicals must be taken into account, as it will be difficult for a bio-based material to compete with very cheap petrochemical-derived products. Thirdly, it must be determined whether the unique properties of the bio-based material open up new end uses and markets. Examples of this would be the use of chiral molecules in special end uses. This prospect may exist for 2,3-BD with its three racemic forms. Another example would be whether the public finds the features of biodegradability, or use of renewable materials, attractive enough to possibly pay more for a product.

It appears that 2,3-BD achieved its peak of commercial interest around World War II due to the shortage of natural rubber. It remains to be seen whether evolving industrial needs will cause renewed interest in a bioprocess for production of 2,3-butanediol.

References

Abbad-Andaloussi S, Manginot-Durr C, Amine J, Petitdemange E, Petitdemange H (1995) Isolation and characterization of *Clostridium butyricum* DSM 5431 mutants with increased resistance to 1,3-propanediol and altered production of acids. *Appl Environ Microbiol* 61:4413–4417

- Abbad-Andaloussi S, Durr C, Raval G, Petitdemange H (1996) Carbon and electron flow in *Clostridium butyricum* grown in chemostat culture on glycerol and glucose. *Microbiology* 142:1149–1158
- Adler HI, Crow W (1987) A technique for predicting the solvent-producing ability of *Clostridium acetobutylicum*. *Appl Environ Microbiol* 53:2496–2499
- Afschar AS, Bellgardt KH, Vaz Rossell CE, Czok A, Schaller K (1991) The production of 2,3-butanediol by fermentation of high test molasses. *Appl Microbiol Biotechnol* 34:582–585
- Afschar AS, Vaz Rossell CE, Jonas R, Quesada Chanto A, Schaller K (1993) Microbial production and downstream processing of 2,3-butanediol. *J Biotechnol* 27:317–329
- Ahrens K, Menzel K, Zeng AP, Deckwer WD (1998) Kinetic, dynamic, and pathway studies of glycerol metabolism by *Klebsiella pneumoniae* in anaerobic continuous culture. III: enzymes and fluxes of glycerol dissimilation and 1,3-propanediol formation. *Biotechnol Bioengin* 59:544–552
- Alam S, Capit F, Weigand WA, Hong J (1990) Kinetics of 2,3-butanediol fermentation by *Bacillus amyloliquefaciens*: effect of initial substrate concentration and aeration. *J Chem Tech Biotechnol* 47:71–84
- Allcock ER, Woods DR (1981) Carboxymethyl cellulase and cellobiase production by *Clostridium acetobutylicum* in an industrial fermentation medium. *Appl Environ Microbiol* 41:539–541
- Allcock ER, Reid SJ, Jones DT, Woods DR (1981) Autolytic activity and an autolysis-deficient mutant of *Clostridium acetobutylicum*. *Appl Environ Microbiol* 42:929–935
- Altaras NE, Cameron DC (1999) Metabolic engineering of a 1,2-propanediol pathway in *Escherichia coli*. *Appl Environ Microbiol* 65:1180–1185
- Altaras NE, Cameron DC (2000) Enhanced production of (R)-1,2-propanediol by metabolically engineered *Escherichia coli*. *Biotechnol Prog* 16:940–946
- Altaras NE, Etzel MR, Cameron DC (2001) Conversion of sugars to 1,2-propanediol by *Thermoanaerobacterium thermosaccharolyticum* HG-8. *Biotechnol Prog* 17:52–56
- Annou B, Blaschek HP (1991) Isolation and characterization of *Clostridium acetobutylicum* mutants with enhanced amyolytic activity. *Appl Environ Microbiol* 57:2544–2548
- Anonymous (1956) Trends of world solvents production for the past ten years and the management of the Chiai (Taiwan) Solvents Works (in Chinese). *Petroleum Communications China Petroleum Corporation Taiwan China June, Issue 60*, pp 42–57
- Anonymous (1958) New direction of development for the Chiai (Taiwan) solvents works (in Chinese) *Petroleum Communications China Petroleum Corporation, Taiwan China May, Issue 83*, pp 6–7
- Anonymous (1996a) Chemical profile: propylene glycol. *Chem Mark Rep* 249:37
- Anonymous (1996b) Facts and figures for the chemical industry: production by the US chemical industry. *Chem Eng News June 24*, 41
- Anonymous (1997) Facts and figures for the chemical industry – production: mixed in 1996. *Chem Eng News June 23*, 41
- Anonymous (1999a) Shell Chemicals Research Team wins ACS 2000 award for innovation. *Chem Mark Rep* 256
- Anonymous (1999b) All-microbial route yields chiral building blocks. *Chem Eng News* 77(8):57
- Anonymous (2001a) Chemical prices. *Chem Mark Rep* 259:8–21
- Anonymous (2001b) Chemical profile: isopropanol. *Chem Mark Rep, November 12*, 31
- Arzberger CF, Peterson WH, Fred EB (1920) Certain factors that influence acetone production by *Bacillus acetoxylicum*. *J Biol Chem* 44:465–479
- Azeddoug H, Hubert J, Reyset G (1992) Stable inheritance of shuttle vectors based on plasmid pIM13 in a mutant strain of *Clostridium acetobutylicum*. *J Gen Microbiol* 138:1371–1378
- Babb BL, Collett HJ, Reid SJ, Woods DR (1993) Transposon mutagenesis of *Clostridium acetobutylicum* P262: isolation and characterization of solvent deficient and metronidazole resistant mutants. *FEMS Microbiol Lett* 114:343–348
- Bahl H, Andersch WA, Braun K, Gottschalk G (1982a) Effect of pH and butyrate concentration on the production of acetone and butanol by *Clostridium acetobutylicum* grown in continuous culture. *Eur J Appl Microbiol Biotechnol* 14:17–20

- Bahl H, Andersch W, Gottschalk G (1982b) Continuous production of acetone and butanol by *Clostridium acetobutylicum* in a two-stage phosphate limited chemostat. *Appl Microbiol Biotechnol* 15:201–205
- Baldus JM, Green BD, Youngman P, Morgan CP Jr (1994) Phosphorylation of *Bacillus subtilis* transcription factor Spo0A stimulates transcription from the spoIIG promoter by enhancing binding to weak OA boxes. *J Bacteriol* 176:296–306
- Ballongue J, Amine J, Masion E, Petitdemange H, Gay R (1985) Induction of acetoacetate decarboxylase in *Clostridium acetobutylicum*. *FEMS Microbiol Lett* 29:273–277
- Barber JM, Robb FT, Webster JR, Woods DR (1979) Bacteriocin production by *Clostridium acetobutylicum* in an industrial fermentation process. *Appl Environ Microbiol* 37:433–437
- Barbirato F, Camarasa-Claret C, Grivet JP, Bories A (1995) Glycerol fermentation by a new 1,3-propanediol-producing microorganism: *enterobacter agglomerans*. *Appl Microbiol Biotechnol* 43:786–793
- Barbirato F, Grivet JP, Soucaille P, Bories A (1996a) 3-Hydroxypropionaldehyde, an inhibitory metabolite of glycerol fermentation to 1,3-propanediol by enterobacterial species. *Appl Environ Microbiol* 62:1448–1451
- Barbirato F, Soucaille P, Bories A (1996b) Physiologic mechanisms involved in accumulation of 3-hydroxypropionaldehyde during fermentation of glycerol by *Enterobacter agglomerans*. *Appl Environ Microbiol* 62:4405–4409
- Barbirato F, Chedaille D, Bories A (1997a) Propionic acid fermentation from glycerol: comparison with conventional substrates. *Appl Microbiol Biotechnol* 47:441–446
- Barbirato F, Astruc S, Soucaille P, Camarasa C, Salmon JM, Bories A (1997b) Anaerobic pathways of glycerol dissimilation by *Enterobacter agglomerans* CNCM 1210: limitations and regulations. *Microbiology* 143:2423–2432
- Barbirato F, Himmi EH, Conte T, Bories A (1998) 1,3-propanediol production by fermentation: an interesting way to valorize glycerin from the ester and ethanol industries. *Ind Crops Prod* 7:281–289
- Bata RM, Elrod AC, Lewandowski TP (1991) Butanol as a blending agent with gasoline for I. C. engines. In: Hurn RW, Marshall WF, Allsup JR (eds) *Oxygenates in motor fuel formulation*. Society of Automotive Engineers, Warrendale, pp 35–40
- Beesch SC (1952) Acetone-butanol fermentation of sugars. *Ind Engin Chem* 44:1677–1682
- Beesch SC (1953) Acetone-butanol fermentation of starches. *Appl Microbiol* 1:85–95
- Bennett GN, Rudolph FB (1995) The central metabolic pathway from acetyl-CoA to butyryl-CoA in *Clostridium acetobutylicum*. *FEMS Microbiol Rev* 17:241–249
- Bennett GN, San KY (2001) Microbial formation, biotechnological production and application of 1,2-propanediol. *Appl Microbiol Biotechnol* 55:1–9
- Bermejo LL, Welker NE, Papoutsakis ET (1998) Expression of *Clostridium acetobutylicum* ATCC 824 genes in *Escherichia coli* for acetone production and acetate detoxification. *Appl Environ Microbiol* 64:1079–1085
- Beronio PB Jr, Tsao GT (1993) Optimization of 2,3-butanediol production by *Klebsiella oxytoca* through oxygen transfer rate control. *Biotechnol Bioengin* 42:1263–1269
- Bertram J, Dü P (1989) Conjugal transfer and expression of streptococcal transposons in *Clostridium acetobutylicum*. *Arch Microbiol* 151:551–557
- Bertram J, Kuhn A, Dü P (1990) Tn916-induced mutants of *Clostridium acetobutylicum* defective in regulation of solvent formation. *Arch Microbiol* 153:373–377
- Biebl H (1991) Glycerol fermentation of 1,3-propanediol by *Clostridium butyricum*: measurement of product inhibition by use of a pH-auxostat. *Appl Microbiol Biotechnol* 35:701–705
- Biebl H, Marten S (1995) Fermentation of glycerol to 1,3-propanediol: use of cosubstrates. *Appl Microbiol Biotechnol* 44:15–19
- Biebl H, Marten S, Hippe H, Deckwer WD (1992) Glycerol conversion to 1,3-propanediol by newly isolated clostridia. *Appl Microbiol Biotechnol* 36:592–597
- Biebl H, Zeng AP, Menzel K, Deckwer WD (1998) Fermentation of glycerol to 1,3-propanediol and 2,3-butanediol by *Klebsiella pneumoniae*. *Appl Microbiol Biotechnol* 50:24–29
- Biebl H, Menzel K, Zeng AP, Deckwer WD (1999) Microbial production of 1,3-propanediol. *Appl Microbiol Biotechnol* 52:289–297
- Billig E (1992) Butyl alcohols. In: Kroschwitz JJ, Howe-Grant M (eds) *Kirk-Othmer encyclopedia of chemical technology*, vol 4, 4th edn. Wiley, New York, pp 691–700
- Birrer GA, Chesbro WR, Zsigray RM (1994) Electro-transformation of *Clostridium beijerinckii* NRRL B-592 with shuttle plasmid pHR106 and recombinant derivatives. *Appl Microbiol Biotechnol* 41:32–38
- Blaschek H, Annous B, Formanek J, Chen CK (2002) Method of producing butanol using a mutant strain of *Clostridium beijerinckii*. US Patent 6358717
- Blomqvist K, Nikkola M, Lehtovaara P, Suihko M-L, Airaksinen U, Straby KB, Knowles JKC, Penttilä ME (1993) Characterization of the genes of the 2,3-butanediol operons from *Klebsiella terrigena* and *Enterobacter aerogenes*. *J Bacteriol* 175:1392–1404
- Boenigk R, Bowien S, Gottschalk G (1993) Fermentation of glycerol to 1,3-propanediol in continuous cultures of *Citrobacter freundii*. *Appl Microbiol Biotechnol* 38:453–457
- Bolt JA (1980) A Survey of alcohol as a motor fuel. In: *Alcohols as motor fuels*. Society of Automotive Engineers, Warrendale, pp 21–33
- Bouvet OMM, Lenormand P, Carlier JP, Grimont PAD (1994) Phenotypic diversity of anaerobic glycerol dissimilation shown by seven enterobacterial species. *Res Microbiol* 145:129–139
- Bowles LK, Ellefson WL (1985) Effects of butanol on *Clostridium acetobutylicum*. *Appl Environ Microbiol* 50:1165–1170
- Bowring SN, Morris JG (1985) Mutagenesis of *Clostridium acetobutylicum*. *J Appl Bacteriol* 58:577–584
- Boynton ZL, Bennett GN, Rudolph FB (1996a) Cloning, sequencing and expression of clustered genes encoding β -hydroxybutyryl-coenzyme A (CoA) dehydrogenase, crotonase, and butyryl-CoA dehydrogenase from *Clostridium acetobutylicum* ATCC 824. *J Bacteriol* 178:3015–3024
- Boynton ZL, Bennett GN, Rudolph FB (1996b) Cloning, sequencing, and expression of genes encoding phosphotransacetylase and acetate kinase from *Clostridium acetobutylicum* ATCC 824. *Appl Environ Microbiol* 62:2758–2766
- Bryant RS (1990) Microbial enhanced oil recovery and compositions therefor. US Patent 4905761
- Bryn K, Stormer FC (1976) Decreased riboflavin formation in mutants of *Aerobacter* (*Enterobacter*) *aerogenes* deficient in the butanediol pathway. *Biochim Biophys Acta* 428:257–259
- Bulthuis BA, Gatenby AA, Laynie SL, Hsu AK, Lareau RD (1998) Method for the production of glycerol by recombinant organisms. Patent Cooperation Treaty (PCT) Application WO 98/21340
- Cameron DC, Cooney CL (1986) A novel fermentation: the production of R(-)-1,2-propanediol and acetol by *Clostridium thermosaccharolyticum*. *Biotechnology* 4:651–654
- Cameron DC, Tong IT, Skraly FA (1993) Metabolic engineering for the production of 1,3-propanediol. In: Chianelli RR, Davison BH (eds) *ACS symposium on bioremediation and bioprocessing*, vol 38. American Chemical Society, Denver CO, pp 294–295
- Cameron DC, Altaras NE, Hoffman ML, Shaw AJ (1998) Metabolic engineering of propanediol pathways. *Biotechnol Prog* 14:16–125
- Cameron DC, Shaw AJ, Altaras NE (2000) Microbial production of 1,2-propanediol from sugar. US Patent 6087140
- Cato EP, George WL, Finegold SM (1986) Genus *Clostridium* Prazmowski 1880. In: Sneath HA, Mair NS, Sharpe ME, Holt JG (eds) *Bergey's manual of systematic bacteriology*, vol 2. Williams and Wilkins, Baltimore, pp 1141–1200
- Champluvier B, Decallonne J, Rouxhet PG (1989) Influence of sugar source (lactose, glucose, galactose) on 2,3-butanediol production by *Klebsiella oxytoca* NRRL-B199. *Arch Microbiol* 152:411–414
- Chen J-S (1993) Properties of acid- and solvent-forming enzymes of clostridia. In: Woods DR (ed) *The clostridia and biotechnology*. Butterworth-Heinemann, Stoneham, pp 51–76
- Chen JS (1995) Alcohol dehydrogenase: multiplicity and relatedness in the solvent-producing clostridia. *FEMS Microbiol Rev* 17:263–273
- Chen C-K, Blaschek HP (1999a) Acetate enhances solvent production and prevents degeneration in *Clostridium beijerinckii* BA101. *Appl Microbiol Biotechnol* 52:170–173

- Chen C-K, Blaschek H (1999b) Effect of acetate on molecular and physiological aspects of *Clostridium beijerinckii* NCIMB 8052 solvent production and strain degeneration. *Appl Environ Microbiol* 65:499–505
- Chen J-S, Hiu SF (1986) Acetone-butanol-isopropanol production by *Clostridium beijerinckii* (synonym, *Clostridium butylicum*). *Biotechnol Lett* 8:371–376
- Chotani G, Dodge T, Hsu A, Kumar M, LaDuca R, Trimbur D, Weyler W, Sanford K (2000) The commercial production of chemicals using pathway engineering. *Biochim Biophys Acta* 1543:434–455
- Clark SW, Bennett GN, Rudolph FB (1989) Isolation and characterization of mutants of *Clostridium acetobutylicum* ATCC 824 deficient in acetoacetyl-coenzyme A: acetate/butyrate: coenzyme A-transferase (EC 2.8.3.9) and in other solvent pathway enzymes. *Appl Environ Microbiol* 55:970–976
- Cocks GT, Aguilar J, Lin ECC (1974) Evolution of L-1,2-propanediol catabolism in *Escherichia coli* by recruitment of enzymes for L-fucose and L-lactate metabolism. *J Bacteriol* 118:83–88
- Colby GD (1993) CoA-transferase and 3-hydroxybutyryl-CoA Dehydrogenases: acetoacetyl-CoA-reacting enzymes from *Clostridium beijerinckii* NRRL B593. PhD thesis, Virginia Polytechnic Institute and State University, Blacksburg VA
- Colby GD, Chen J-S (1992) Purification and properties of 3-hydroxybutyryl-coenzyme A dehydrogenase from *Clostridium beijerinckii* (“*Clostridium butylicum*”) NRRL B593. *Appl Environ Microbiol* 58:3297–3302
- Colin T, Bories A, Moulin G (2000) Inhibition of *Clostridium butyricum* by 1,3-propanediol and diols during glycerol fermentation. *Appl Microbiol Biotechnol* 54:201–205
- Collins MD, Lawson PA, Willems A, Cordoba JJ, Fernandez-Garayzabal J, Garcia P, Cai J, Hippe H, Farrow JAE (1994) The phylogeny of the genus *Clostridium*: proposal of five new genera and eleven new species combinations. *Int J Syst Bacteriol* 44:812–826
- Compere AL, Griffith WL (1979) Evaluation of substrates for butanol production. *Dev Ind Microbiol* 20:509–517
- Compere AL, Griffith WL, Googin JM (1985) Solvents production by clostridia as a function of wood stream organic toxicant concentration. *Dev Ind Microbiol* 26:535–541
- Cornillot E, Soucaille P (1996) Solvent-forming genes in clostridia. *Nature* 380:489
- Cornillot E, Croux C, Soucaille P (1997a) Physical and genetic map of the *Clostridium acetobutylicum* ATCC 824 chromosome. *J Bacteriol* 179:7426–7434
- Cornillot E, Nair RV, Papoutsakis ET, Soucaille P (1997b) The genes for butanol and acetone formation in *Clostridium acetobutylicum* ATCC 824 reside on a large plasmid whose loss leads to degeneration of the strain. *J Bacteriol* 179:5442–5447
- Croux C, Garcia JL (1991) Sequence of the lyc gene encoding the autolytic lysozyme of *Clostridium acetobutylicum* ATCC 824: comparison with other lytic enzymes. *Gene* 104:25–31
- Croux C, Garcia JL (1992) Reconstruction and expression of the autolytic gene from *Clostridium acetobutylicum* ATCC 824 in *Escherichia coli*. *FEMS Microbiol Lett* 95:13–20
- Croux C, Canard B, Goma G, Soucaille P (1992a) Autolysis of *Clostridium acetobutylicum* ATCC 824. *J Gen Microbiol* 138:861–869
- Croux C, Canard B, Goma G, Soucaille P (1992b) Purification and characterization of an extracellular muramidase of *Clostridium acetobutylicum* ATCC 824 that acts on non-N-acetylated peptidoglycan. *Appl Environ Microbiol* 58:1075–1081
- Cueto PH, Mendez BS (1990) Direct selection of *Clostridium acetobutylicum* fermentation mutants by a protein suicide method. *Appl Environ Microbiol* 56:578–580
- Cummins C, Johnson JL (1971) Taxonomy of the clostridia: wall composition and DNA homologies in *Clostridium butyricum* and other butyric acid-producing clostridia. *J Gen Microbiol* 67:33–46
- Dabrock B, Bahl H, Gottschalk G (1992) Parameters affecting solvent production by *Clostridium pasteurianum*. *Appl Environ Microbiol* 58:1233–1239
- Daniel R, Gottschalk G (1992) Growth temperature-dependent activity of glycerol dehydratase in *Escherichia coli* expressing the *Citrobacter freundii* dha regulon. *FEMS Microbiol Lett* 100:281–286
- Daniel R, Boenigk R, Gottschalk G (1995a) Purification of 1,3-propanediol dehydrogenase from iand cloning, sequencing, and overexpression of the corresponding gene in *Escherichia coli*. *J Bacteriol* 177:2151–2156
- Daniel R, Stuert K, Gottschalk G (1995b) Biochemical and molecular characterization of the oxidative branch of glycerol utilization by *Citrobacter freundii*. *J Bacteriol* 177:4392–4401
- Daniel R, Bobik TA, Gottschalk G (1999) Biochemistry of coenzyme B12-dependent glycerol and diol dehydratases and organization of the encoding genes. *FEMS Microbiol Rev* 22:553–566
- de Mas C, Jansen NB, Tsao GT (1988) Production of optically active 2,3-butanediol by *Bacillus polymyxa*. *Biotechnol Bioengin* 31:366–377
- Deckwer WD (1995) Microbial conversion of glycerol to 1,3-propanediol. *FEMS Microbiol Rev* 16:143–149
- Desai RP, Papoutsakis ET (1999) Antisense RNA strategies for metabolic engineering of *Clostridium acetobutylicum*. *Appl Environ Microbiol* 65:936–945
- Diaz-Torres M, Dunn-Coleman NS, Chase MW, Trimbur D (2000) Method for the recombinant production of 1,3-propanediol. US Patent 6136576
- Dürre P (1998) New insights and novel developments in clostridial acetone/butanol/isopropanol fermentation. *Appl Microbiol Biotechnol* 49:639–648
- Dürre P, Bahl H (1996) Microbial production of acetone/butanol/isopropanol. In: Roehr M (ed) *Products of primary metabolism*, vol 6, 2nd edn. VCH, Weinheim, pp 229–268
- Dürre P, Fischer RJ, Kuhn A, Lorenz K, Schreiber W, Stürzenhofecker B, Ullmann S, Winzer K, Sauer U (1995) Solventogenic enzymes of *Clostridium acetobutylicum*, catalytic properties, genetic organization and transcriptional regulation. *FEMS Microbiol Rev* 17:251–262
- Dürre P, Bohringer M, Nakotte S, Schaffer S, Thormann K, Zickner B (2002) Transcriptional regulation of solventogenesis in *Clostridium acetobutylicum*. *J Molec Microbiol Biotechnol* 4:295–300
- Eiteman MA, Miller JH (1995) Effect of succinic acid on 2,3-butanediol production by *Klebsiella oxytoca*. *Biotechnol Lett* 17:1057–1062
- Ennis BM, Maddox IS (1985) Use of *Clostridium acetobutylicum* P262 for production of solvents from whey permeate. *Biotechnol Lett* 7:601–606
- Evans VJ, Liyanage H, Ravagnani A, Young M, Kashket ER (1998) Truncation of peptide deformylase reduces the growth rate and stabilizes solvent production in *Clostridium beijerinckii* NCIMB 8052. *Appl Environ Microbiol* 64:1780–1785
- Fernbach A, Strange EH (1911) Acetone and higher alcohols (amyl, butyl or ethyl alcohols and butyric, propionic or acetic acid) from starches, sugars and other carbohydrates. British Patent 15203–15204
- Fischer RJ, Helms J, Dü P (1993) Cloning, sequencing and molecular analysis of the sol operon of *Clostridium acetobutylicum*, a chromosomal locus involved in solventogenesis. *J Bacteriol* 175:6959–6969
- Fond O, Jansen NB, Tsao GT (1985) A model of acetic acid and 2,3-butanediol inhibition of the growth and metabolism of *Klebsiella oxytoca*. *Biotechnol Lett* 7:727–732
- Fond O, Engasser JM, Matta-El-Amouri G, Petitdemange H (1986a) The acetone butanol fermentation on glucose and xylose. I: regulation and kinetics in batch cultures. *Biotechnol Bioengin* 28:160–166
- Fond O, Engasser JM, Matta-El-Amouri G, Petitdemange H (1986b) The acetone butanol fermentation on glucose and xylose. II: regulation and kinetics in fed-batch cultures. *Biotechnol Bioengin* 28:167–175
- Fontaine L, Meynial-Salles I, Girbal L, Yang X, Croux C, Soucaille P (2002) Molecular characterization and transcriptional analysis of adhE2, the gene encoding the NADH-dependent aldehyde/alcohol dehydrogenase responsible for butanol production in alcohologenic cultures of *Clostridium acetobutylicum* ATCC 824. *J Bacteriol* 184:821–830
- Forage RG, Foster MA (1982) Glycerol fermentation in *Klebsiella pneumoniae*: functions of the coenzyme B12-dependent glycerol and diol dehydratases. *J Bacteriol* 149:413–419
- Forage RG, Lin ECC (1982) Dha system mediating aerobic and anaerobic dissimilation of glycerol in *Klebsiella pneumoniae* NCIB 418. *J Bacteriol* 151:591–599
- Frazer FR, McCaskey TA (1991) Effect of components of acid-hydrolyzed hardwood on conversion of D-xylose to 2,3-butanediol by *Klebsiella pneumoniae*. *Enz Microb Technol* 13:110–115

- Freier-Schroeder D, Wiegel J, Gottschalk G (1989) Butanol formation by *Clostridium thermosaccharolyticum* at neutral pH. *Biotechnol Lett* 11:831–836
- Gabriel CL (1928) Butanol fermentation process. *Ind Engin Chem* 20:1063–1067
- Gabriel CL, Crawford FM (1930) Development of the butyl-acetonic fermentation industry. *Ind Engin Chem* 22:1163–1165
- Gapes JR (2000a) The economics of the acetone-butanol fermentation: theoretical and market considerations. *J Molec Microbiol Biotechnol* 2:27–32
- Gapes JR (2000b) The history of the acetone-butanol project in Austria. *J Molec Microbiol Biotechnol* 2:5–8
- Gapes JR, Nimcevic D, Friedl A (1996) Long-term continuous cultivation of *Clostridium beijerinckii* in a two-stage chemostat with on-line solvent removal. *Appl Environ Microbiol* 62:3210–3219
- Garg SK, Jain A (1995) Fermentative production of 2,3-butanediol: a review. *Biores Technol* 51:103–109
- George HA, Chen J-S (1983) Acidic conditions are not obligatory for onset of butanol formation by *Clostridium beijerinckii* (synonym, *C. butylicum*). *Appl Environ Microbiol* 46:321–327
- George HA, Johnson JL, Moore WEC, Holdeman LV, Chen J-S (1983) Acetone, isopropanol, and butanol production by *Clostridium beijerinckii* (syn. *Clostridium butylicum*) and *Clostridium aurantibutyricum*. *Appl Environ Microbiol* 45:1160–1163
- Gerischer U, Dü P (1990) Cloning, sequencing, and molecular analysis of the acetoacetate decarboxylase gene region from *Clostridium acetobutylicum*. *J Bacteriol* 172:6907–6918
- Ghazvinizadeh H, Turtura GC, Zambonelli C (1972) The fermentation of L-rhamnose by clostridia. *Ann Microbiol* 22:155–158
- Gibbs DF (1983) The rise and fall (...and rise?) of acetone/butanol fermentations. *Trends Biotechnol* 1:12–15
- Girbal L, Soucaille P (1994) Regulation of *Clostridium acetobutylicum* metabolism as revealed by mixed-substrate steady-state continuous cultures: Role of NADH/NAD ratio and ATP pool. *J Bacteriol* 176:6433–6438
- Girbal L, Soucaille P (1998) Regulation of solvent production in *Clostridium acetobutylicum*. *Trends Biotechnol* 16:11–16
- Girbal L, Croux C, Vasconcelos I, Soucaille P (1995a) Regulation of metabolic shifts in *Clostridium acetobutylicum* ATCC 824. *FEMS Microbiol Rev* 17:287–297
- Girbal L, Vasconcelos I, Saint-Amans S, Soucaille P (1995b) How neutral red modified carbon and electron flow in *Clostridium acetobutylicum* grown in chemostat culture at neutral pH. *FEMS Microbiol Rev* 16:151–162
- Godin C, Engasser JM (1990) Two-stage continuous fermentation of *Clostridium acetobutylicum*: effects of pH and dilution rate. *Appl Microbiol Biotechnol* 33:269–273
- Gottwald M, Gottschalk G (1985) The internal pH of *Clostridium acetobutylicum* and its effect on the shift from acid to solvent formation. *Arch Microbiol* 143:42–46
- Gottwald M, Hippe H, Gottschalk G (1984) Formation of n-butanol from D-glucose by strains of the “*Clostridium tetanomorphum*” group. *Appl Environ Microbiol* 48:573–576
- Goupil-Feuillerat N, Coccagn-Bousquet M, Godon J-J, Ehrlich SD, Renault P (1997) Dual role of α -acetylacetyl decarboxylase in *Lactococcus lactis* subsp. *lactis*. *J Bacteriol* 179:6285–6293
- Green EM, Bennett GN (1996) Inactivation of an aldehyde/alcohol dehydrogenase gene from *Clostridium acetobutylicum* ATCC 824. *Appl Biochem Biotechnol* 57/58:213–221
- Green EM, Boynton ZL, Harris LM, Rudolph FB, Papoutsakis ET, Bennett GN (1996) Genetic manipulation of acid formation pathways by gene inactivation in *Clostridium acetobutylicum* ATCC 824. *Microbiology* 142:2079–2086
- Greenberg K (1999) New PDO technologies create opportunities. *Chem Mark Rep* 255 4 and 9
- Grove LH (1982) Process for the production of organic fuel. US Patent 4326032
- Grupe H, Gottschalk G (1992) Physiological events in *Clostridium acetobutylicum* during the shift from acidogenesis to solventogenesis in continuous culture and presentation of a model for shift induction. *Appl Environ Microbiol* 58:3896–3902
- Gunzel B, Yonsel S, Deckwer WD (1991) Fermentative production of 1,3-propanediol from glycerol by *Clostridium butyricum* up to a scale of 2 m³. *Appl Microbiol Biotechnol* 36:289–294
- Gutierrez NA, Maddox IS (1992) Product inhibition in a nonmotile mutant of *Clostridium acetobutylicum*. *Enz Microbiol Technol* 14:101–105
- Hamilton GA, Westheimer FH (1959) A crystalline decarboxylase without biotin. *J Am Chem Soc* 81:2277
- Hancock KR, Rockman E, Young CA, Pearce L, Maddox IS, Scott DB (1991) Expression and nucleotide sequence of the *Clostridium acetobutylicum* β -galactosidase gene cloned in *Escherichia coli*. *J Bacteriol* 173:3084–3095
- Harris J, Mulder R, Kell DB, Walter RP, Morris JG (1986) Solvent production by *Clostridium pasteurianum* in media of high sugar content. *Biotechnol Lett* 8:889–892
- Harris LM, Desai RP, Welker NE, Papoutsakis ET (2000) Characterization of recombinant strains of the *Clostridium acetobutylicum* butyrate kinase inactivation mutant: need for new phenomenological models for solventogenesis and butanol inhibition? *Biotechnol Bioengin* 67:1–11
- Harris LM, Welker NE, Papoutsakis ET (2002) Northern, morphological, and fermentation analysis of spo0A inactivation and overexpression in *Clostridium acetobutylicum* ATCC 824. *J Bacteriol* 184:3586–3597
- Hartmanis MGN (1987) Butyrate kinase from *Clostridium acetobutylicum*. *J Biol Chem* 262:617–621
- Hasting JH (1978) Acetone-butyl alcohol fermentation. In: Rose AH (ed) *Primary products of metabolism*. Academic, London, pp 31–45
- Hastings JH (1971) Development of the fermentation industries in Great Britain. *Adv Appl Microbiol* 14:1–45
- Haynie SL, Wagner LW (1997) Process for making 1,3-propanediol from carbohydrates using mixed microbial cultures. US Patent 5599689
- Hermann M, Fayolle F, Marchal R, Podvin L, Sebald M, Vandecasteele J-P (1985) Isolation and characterization of butanol-resistant mutants of *Clostridium acetobutylicum*. *Appl Environ Microbiol* 50:1238–1243
- Heyndrickx M, De Vos P, Vancanneyt M, De Ley J (1991) The fermentation of glycerol by *Clostridium butyricum* LMG 1212 t2 and 1213 t1 and *C. pasteurianum* LMG 3285. *Appl Microbiol Biotechnol* 34:637–642
- Himmi EH, Bories A, Barbirato F (1999) Nutrient requirements for glycerol conversion to 1,3-propanediol by *Clostridium butyricum*. *Biores Technol* 67:123–138
- Hui SF, Zhu C-X, Yan R-T, Chen J-S (1987) Butanol-ethanol dehydrogenase and butanol-ethanol-isopropanol dehydrogenase: different alcohol dehydrogenases in two strains of *Clostridium beijerinckii* (*Clostridium butylicum*). *Appl Environ Microbiol* 53:697–703
- Hoffman J (2001) Butadiene hit hard by sharp drop in derivatives demand. *Chem Mark Rep* 260:1 and 12
- Holt RA, Stephens GM, Morris JG (1984) Production of solvents by *Clostridium acetobutylicum* cultures maintained at neutral pH. *Appl Environ Microbiol* 48:1166–1170
- Holt RA, Cairns AJ, Morris JG (1988) Production of butanol by *Clostridium puniceum* in batch and continuous culture. *Appl Microbiol Biotechnol* 27:319–324
- Homann T, Tag C, Biehl H, Deckwer WD, Schink B (1990) Fermentation of glycerol to 1,3-propanediol by Klebsiella and Citrobacter strains. *Appl Microbiol Biotechnol* 33:121–126
- Hong R (1999) The cloning of a putative regulatory gene and the sol region from *Clostridium beijerinckii*. M.S. thesis Virginia Polytechnic Institute and State University, Blacksburg VA
- Hongo M, Murata A (1965a) Bacteriophages of *Clostridium saccharoperbutylacetonicum*. Part I: some characteristics of the twelve phages obtained from the abnormally fermented broths. *Agric Biol Chem* 29:1135–1139
- Hongo M, Murata A (1965b) Bacteriophages of *Clostridium saccharoperbutylacetonicum*. Part II: enumeration of phages by the application of the plaque count technique and some factors influencing the plaque formation. *Agric Biol Chem* 29:1140–1145
- Houben MCM (1995) Oxygenated blending components for gasoline-alcohols and ethers. In: Marshall EL, Owen K (eds) *Motor gasoline: critical reports on applied chemistry*, vol 34, Royal Society of Chemistry. Cambridge, UK, pp 45–71

- Howard WL (1991) Acetone. In: Kroschwitz JI, Howe-Grant M (eds) Kirk-Othmer encyclopedia of chemical technology, vol 1, 4th edn. Wiley, New York, pp 176–194
- Huang K-X, Rudolph FB, Bennett GN (1999) Characterization of methylglyoxal synthase from *Clostridium acetobutylicum* ATCC 824 and its use in the formation of 1,2-propanediol. *Appl Environ Microbiol* 65:3244–3247
- Huang K-X, Huang S, Rudolph FB, Bennett GN (2000) Identification and characterization of a second butyrate kinase from *Clostridium acetobutylicum* ATCC 824. *J Molec Microbiol Biotechnol* 2:33–38
- Husemann M, Papoutsakis ET (1986) Effect of acetoacetate, butyrate, and uncoupling ionophores on growth and product formation of *Clostridium acetobutylicum*. *Biotechnol Lett* 8:37–42
- Husemann MHW, Papoutsakis ET (1988) Solventogenesis in *Clostridium acetobutylicum* fermentations related to carboxylic acid and proton concentrations. *Biotechnol Bioengin* 32:843–852
- Husemann MHW, Papoutsakis ET (1989) Comparison between in vivo and in vitro enzyme activities in continuous and batch fermentations of *Clostridium acetobutylicum*. *Appl Microbiol Biotechnol* 30:585–595
- Inoue Y, Kimura A (1995) Methylglyoxal and regulation of its metabolism in microorganisms. *Adv Microb Physiol* 37:177–227
- Ismaiel AA, Chen JS (1998) Purification of the aldehyde-alcohol dehydrogenase encoded by the aad gene from *Clostridium acetobutylicum* ATCC 824. In: Abstracts of the 98th general meeting of the American Society of Microbiology American Society for Microbiology, Washington, DC, pp O-40 400
- Ismaiel AA, Zhu C-X, Colby GD, Chen J-S (1993) Purification and characterization of a primary-secondary alcohol dehydrogenase from two strains of *Clostridium beijerinckii*. *J Bacteriol* 175:5097–5105
- Jansen NB, Tsao GT (1983) Bioconversion of pentoses to 2,3-butanediol by *Klebsiella pneumoniae*. In: Fiechter A, Jeffries TW (eds) Advances in biochemical engineering/biotechnology, vol 27. Springer, New York, pp 85–99
- Jansen NB, Flickinger MC, Tsao GT (1984) Production of 2,3-butanediol from D-xylose by *Klebsiella oxytoca* ATCC 8724. *Biotechnol Bioengin* 26:362–369
- Johansen L, Bryn K, Stormer FC (1975) Physiological and biochemical role of the butanediol pathway in *Aerobacter* (Enterobacter) aerogenes. *J Bacteriol* 123:1124–1130
- Johnson JL (1984) Bacterial classification. III: nucleic acids in bacterial classification. In: Krieg NR, Holt JG (eds) *Bergey's manual of systematic bacteriology*, vol 1. Williams and Wilkins, Baltimore, pp 8–11
- Johnson JL, Chen J-S (1995) Taxonomic relationships among strains of *Clostridium acetobutylicum* and other phenotypically similar organisms. *FEMS Microbiol Rev* 17:233–240
- Johnson JL, Toth J, Santiwatanakul S, Chen J-S (1997) Cultures of “*Clostridium acetobutylicum*” from various collections comprise *Clostridium acetobutylicum*, *Clostridium beijerinckii*, and two other distinct types based on DNA-DNA reassociation. *Int J Syst Bacteriol* 47:420–424
- Jones DT, Keis S (1995) Origins and relationships of industrial solvent-producing clostridial strains. *FEMS Microbiol Rev* 17:223–232
- Jones DT, Woods DR (1986) Acetone-butanol fermentation revisited. *Microbiol Rev* 50:484–524
- Jones DT, Jones WA, Woods DR (1985) Production of recombinants after protoplast fusion in *Clostridium acetobutylicum* P262. *J Gen Microbiol* 131:1213–1216
- Jones DT, Shirley M, Wu X, Keis S (2000) Bacteriophage infections in the industrial AB fermentation process. *J Molec Microbiol Biotechnol* 2:21–26
- Junelles A-M, Janati-Idrissi R, El Kanouni A, Petitdemange H, Gay R (1987) Acetone-butanol fermentation by mutants selected for resistance to acetate and butyrate halogen analogues. *Biotechnol Lett* 9:175–178
- Juni E, Heym GA (1956) A cyclic pathway for the bacterial dissimilation of 2,3-butanediol, acetylmethylcarbinol, and diacetyl. I: general aspects of the 2,3-butanediol cycle. *J Bacteriol* 71:425–432
- Kashket ER, Cao ZY (1995) Clostridial strain degeneration. *FEMS Microbiol Rev* 17:307–315
- Keis S, Bennett CF, Ward VK, Jones DT (1995) Taxonomy and phylogeny of industrial solvent-producing clostridia. *Int J Syst Bacteriol* 45:693–705
- Keis S, Shaheen R, Jones DT (2001a) Emended description of *Clostridium acetobutylicum* and *Clostridium beijerinckii* and descriptions of *Clostridium saccharoperbutylacetonicum* sp. nov. and *Clostridium saccharobutylicum* sp. nov. *Int J Syst Evol Microbiol* 51:2095–2103
- Keis S, Sullivan JT, Jones DT (2001b) Physical and genetic map of the *Clostridium saccharobutylicum* (formerly *Clostridium acetobutylicum*) NCP 262 chromosome. *Microbiology* 147:1909–1922
- Kelly FC (1936) One thing leads to another. Houghton Mifflin, Boston
- Killeffer DH (1927) Butanol and acetone from corn. *Ind Engin Chem* 19:46–50
- Korkhin Y, Kalb (Gilboa) AJ, Peretz M, Bogin O, Burstein Y, Frolov F (1998) NADP-dependent bacterial alcohol dehydrogenases: crystal structure, cofactor-binding and cofactor specificity of the ADHs of *Clostridium beijerinckii* and *Thermoanaerobacter brockii*. *J Molec Biol* 278:67–981
- Kutzenok A, Aschner M (1952) Degenerative processes in a strain of *Clostridium butylicum*. *J Bacteriol* 64:829–836
- Ladisch MR (1991) Fermentation-derived butanol and scenarios for its uses in energy-related applications. *Enz Microbiol Technol* 13:280–283
- Laffend LA, Nagarajan V, Nakamura CE (1997) Bioconversion of a fermentable carbon source to 1,3-propanediol by a single microorganism. US Patent 5686276
- Laffend LA, Nagarajan V, Nakamura CE (2000) Bioconversion of a fermentable carbon source to 1,3-propanediol by a single microorganism. US Patent 6025184
- Largier ST, Long S, Santangelo JD, Jones DT, Woods DR (1985) Immobilized *Clostridium acetobutylicum* P 262 mutants for solvent production. *Appl Environ Microbiol* 50:477–481
- Larsen SH, Stormer FC (1973) Diacetyl (Acetoin) reductase from *Aerobacter aerogenes*. *Eur J Biochem* 34:100–106
- Laube VM, Groleau D, Martin SM (1984) 2,3-butanediol production from xylose and other hemicellulosic components by *Bacillus polymyxa*. *Biotechnol Lett* 6:257–262
- Lee HK, Maddox IS (1986) Continuous production of 2,3-butanediol from whey permeate using *Klebsiella pneumoniae* immobilized in calcium alginate. *Enz Microb Technol* 8:409–411
- Lee SF, Forsberg CW, Gibbins LN (1985) Cellulolytic activity of *Clostridium acetobutylicum*. *Appl Environ Microbiol* 50:220–228
- Lee SY, Bennett GN, Papoutsakis ET (1992) Construction of *Escherichia coli*-*Clostridium acetobutylicum* shuttle vectors and transformation of *Clostridium acetobutylicum* strains. *Biotechnol Lett* 14:427–432
- Lemme CJ, Frankiewicz JR (1985) Strains of *Clostridium acetobutylicum* and process for its preparation. US Patent 4521516
- Lemmel SA (1985) Mutagenesis in *Clostridium acetobutylicum*. *Biotechnol Lett* 7:711–716
- Lemmel SA, Datta R, Frankiewicz JR (1986) Fermentation of xylan by *Clostridium acetobutylicum*. *Enz Microbiol Technol* 8:217–221
- Lenz TG, Moreira AR (1980) Economic evaluation of the acetone-butanol fermentation. *Ind Engin Chem Prod Res Devel* 19:478–483
- Lepage C, Fayolle F, Hermann M, Vandecasteele J-P (1987) Changes in membrane liquid composition of *Clostridium acetobutylicum* during acetone-butanol fermentation: effects of solvents, growth temperature and pH. *J Gen Microbiol* 133:103–110
- Li G (1998) Development of a reporter system for the study of gene expression for solvent production in *Clostridium beijerinckii* NRRL B582 and *Clostridium acetobutylicum* ATCC 824. PhD thesis, Virginia Polytechnic Institute and State University, Blacksburg VA
- Lin Y-L, Blaschek HP (1984) Transformation of heat-treated *Clostridium acetobutylicum* protoplasts with pUB110 plasmid DNA. *Appl Environ Microbiol* 48:737–742
- Logsdon JE, Loke RA (1996) Isopropyl alcohol. In: Kroschwitz JI, Howe-Grant M (eds) Kirk-Othmer encyclopedia of chemical technology, vol 20, 4th edn. Wiley, New York, pp 216–240
- Logsdon JE, Loke RA (1999) Isopropyl alcohols. In: Kroschwitz JI (ed) Kirk-Othmer concise encyclopedia of chemical technology, 4th edn. Wiley, New York, pp 1654–1656
- Luers FM, Seyfried R, Daniel R, Gottschalk G (1997) Glycerol conversion to 1,3-propanediol by *Clostridium pasteurianum*: cloning and expression of

- the gene encoding 1,3-propanediol dehydrogenase. *FEMS Microbiol Lett* 154:337–345
- Lund BM, Brocklehurst TF, Wyatt GM (1981) Characterization of strains of *Clostridium puniceum* sp. nov., a pink-pigmented, pectolytic bacterium. *J Gen Microbiol* 122:17–26
- Macis L, Daniel R, Gottschalk G (1998) Properties and sequence of the coenzyme B12-dependent glycerol dehydratase of *Clostridium pasteurianum*. *FEMS Microbiol Lett* 164:21–28
- Maddox IS (1980) Production of n-butanol from whey filtrate using *Clostridium acetobutylicum* NCIB 2951. *Biotechnol Lett* 2:493–498
- Maddox IS, Steiner E, Hirsch S, Wessner S, Gutierrez NA, Gapes JR, Schuster KC (2000) The cause of “acid crash” and “acidogenic fermentations” during the batch acetone-butanol-ethanol (ABE-) fermentation process. *J Molec Microbiol Biotechnol* 2:95–100
- Malinowski JJ (1999) Evaluation of liquid extraction potentials for downstream separation of 1,3-propanediol. *Biotechnol Tech* 13:127–130
- Malinowski JJ (2000) Reactive extraction for downstream separation of 1,3-propanediol. *Biotechnol Prog* 16:76–79
- Marchal R, Ropars M, Pourquie J, Fayolle F, Vandecasteele JP (1992) Large-scale enzymatic hydrolysis of agricultural lignocellulosic biomass. Part II: conversion into acetone-butanol. *Biores Technol* 42:205–217
- Mattsson DM, Rogers P (1994) Analysis of Tn916-induced mutants of *Clostridium acetobutylicum* altered in solventogenesis and sporulation. *J Ind Microbiol* 13:258–268
- McCoy E, Fred EB (1941) The stability of a culture for industrial fermentation. *J Bacteriol* 41:90–91
- McCoy E, McClung LS (1935) Studies on anaerobic bacteria. *J Infect Dis* 56:333–346
- McCoy E, Fred EB, Peterson WH, Hastings EG (1926) A cultural study of the acetone butyl alcohol organism. *J Infect Dis* 39:457–483
- McCutchan WN, Hickey RJ (1954) The butanol-acetone fermentations. In: Underkofler LA, Hickey RJ (eds) *Industrial fermentations*, vol 1. Chemical Publishing, New York, pp 347–388
- McNeil B, Kristiansen B (1986) The acetone butanol fermentation. *Adv Appl Microbiol* 31:61–92
- Meinecke B, Bahl H, Gottschalk G (1984) Selection of an asporogenous strain of *Clostridium acetobutylicum* in continuous culture under phosphate limitation. *Appl Environ Microbiol* 48:1064–1065
- Menzel K, Zeng AP, Deckwer WD (1997) High concentration and productivity of 1,3-propanediol from continuous fermentation of glycerol by *Klebsiella pneumoniae*. *Enz Microbiol Technol* 20:82–86
- Mermelstein LD, Papoutsakis ET (1993a) Evaluation of macrolide and lincosamide antibiotics for plasmid maintenance in low pH *Clostridium acetobutylicum* ATCC 824 fermentations. *FEMS Microbiol Lett* 113:71–76
- Mermelstein LD, Papoutsakis ET (1993b) In vivo methylation in *Escherichia coli* by the *Bacillus subtilis* phage 3 T I methyltransferase to protect plasmids from restriction upon transformation of *Clostridium acetobutylicum* ATCC 824. *Appl Environ Microbiol* 59:1077–1081
- Mermelstein LD, Welker NE, Bennett GN, Papoutsakis ET (1992) Expression of cloned homologous fermentative genes in *Clostridium acetobutylicum* ATCC 824. *Biotechnology* 10:190–195
- Mermelstein LD, Papoutsakis ET, Petersen DJ, Bennett GN (1993) Metabolic engineering of *Clostridium acetobutylicum* ATCC 824 for increased solvent production by enhancement of acetone formation enzyme activities using a synthetic acetone operon. *Biotechnol Bioengin* 42:1053–1060
- Mickelson MN, Werkman CH (1940) Formation of trimethyleneglycol from glycerol by *Aerobacter*. *Enzymologia* 8:252–256
- Minton NP, Oultram JD (1988) Host-vector systems for gene cloning in *Clostridium*. *Microbiol Sci* 5:310–315
- Mitchell WJ (1998) Physiology of carbohydrate to solvent conversion by clostridia. *Adv Microb Physiol* 39:31–130
- Monot F, Engasser J-M, Petitdemange H (1984) Influence of pH and undissociated butyric acid in the production of acetone and butanol in batch cultures of *Clostridium acetobutylicum*. *Appl Microbiol Biotechnol* 19:422–426
- Montoya D, Arevalo C, Gonzales S, Aristizabal F, Schwarz WH (2001) New solvent-producing *Clostridium* sp. strains, hydrolyzing a wide range of polysaccharides, are closely related to *Clostridium butyricum*. *J Ind Microbiol Biotechnol* 27:329–335
- Moore SK (1999) DuPont, Genencor close in on biological propanediol route. *Chem Week* 161:17
- Moreira AR, Ulmer DC, Linden JC (1981) Butanol toxicity in butylic fermentation. *Biotechnol Bioengin Symp* 11:567–579
- Nagarajan V, Nakamura CE (1998) Production of 1,3-propanediol from glycerol by recombinant bacteria expressing recombinant diol dehydratase. US Patent 5821092
- Nair RV, Bennett GN, Papoutsakis ET (1994) Molecular characterization of an alcohol/aldehyde dehydrogenase gene of *Clostridium acetobutylicum* ATCC 824. *J Bacteriol* 176:871–885
- Nakamura CE, Gatenby AA, Hsu AK, LaReau RD, Haynie SL, Diaz-Torres R, Trimbur DE, Whited GM, Nagarajan A, Payne MS, Picataggio SK, Nair RV (2000) Method for the production of 1,3-propanediol by recombinant microorganisms. US Patent 6013494
- Nakas JP, Schaele M, Parkinson CM, Coonley CE, Tanenbaum SW (1983) System development for linked-fermentation production of solvents from algal biomass. *Appl Environ Microbiol* 46:1017–1023
- Nakashimada Y, Kanai K, Nishio N (1998) Optimization of dilution rate, pH and oxygen supply on optical purity of 2,3-butanediol produced by *Paenibacillus polymyxa* in chemostat culture. *Biotechnol Lett* 20:113–1138
- Nakashimada Y, Marwoto B, Kashiwamura T, Kakizono T, Nishio N (2000) Enhanced 2,3-butanediol production by addition of acetic acid in *Paenibacillus polymyxa*. *J Biosci Bioeng* 90:661–664
- Nakotte S, Schaffer S, Bohringer M, Dü P (1998) Electroporation of, plasmid isolation from and plasmid conservation in *Clostridium acetobutylicum* DSM 792. *Appl Microbiol Biotechnol* 50:564–567
- Nativel F, Pourquie J, Ballerini D, Vandecasteele JP, Renault P (1992) The biotechnology facilities at Soustons for biomass conversion. *Int J Solar Energy* 11:219–229
- Nilegaonkar S, Bhosale SB, Kshirsagar DC, Kapadi AH (1992) Production of 2,3-butanediol from glucose by *Bacillus licheniformis*. *World J Microbiol Biotechnol* 8:378–381
- Nimcevic D, Gapes JR (2000) The acetone-butanol fermentation in pilot plant and pre-industrial scale. *J Molec Microbiol Biotechnol* 2:15–20
- Nimcevic D, Schuster M, Gapes JR (1998) Solvent production by *Clostridium beijerinckii* NRRL B592 growing on different potato media. *Appl Microbiol Biotechnol* 50:426–428
- Nölling J, Breton G, Omelchenko MV, Markarova KS, Zeng Q, Gibson R, Lee HM, DuBois J, Qiu D, Hitti J, GTC Sequencing Center Production, Finishing, and Bioinformatics Teams, Wolf YI, Tatusov RL, Sabathe F, Doucette-Stamm L, Soucaille P, Daly MJ, Bennett GN, Koonin EV, Smith DR (2001) Genome sequence and comparative analysis of the solvent-producing bacterium *Clostridium acetobutylicum*. *J Bacteriol* 183:4823–4838
- Noon R (1982) Power-grade butanol. *Chemtech* 12:681–683
- Northrop JH, Ashe LH, Senior JK (1919) Biochemistry of *Bacillus acetoethylicum* with reference to the formation of acetone. *J Biol Chem* 39:1–21
- Ogata S, Hongo M (1979) Bacteriophages of the genus *Clostridium*. *Adv Appl Microbiol* 25:241–273
- Oiwa H, Naganuma M, Ohnuma S-I (1987) Acetone-butanol production from dahlia inulin by *Clostridium pasteurianum* var. I-53. *Agric Biol Chem* 51:2819–2820
- O'Neill H, Mayhew SG, Butler G (1998) Cloning and analysis of the genes for a novel electron-transferring flavoprotein from *Megasphaera elsdenii*. *J Biol Chem* 273:21015–21024
- Osuna J, Soberon X, Morett E (1997) A proposed architecture for the central domain of the bacterial enhancer-binding proteins based on secondary structure prediction and fold recognition. *Protein Sci* 6:543–555
- Oude Elferink SJWH, Krooneman J, Gorrschal JC, Spoelstra SF, Faber F, Driehuis F (2001) Anaerobic conversion of lactic acid to acetic acid and 1,2-propanediol by *Lactobacillus buchneri*. *Appl Environ Microbiol* 67:125–132
- Ouellette J (2000) PO and PG markets face tight margins. *Chem Mark Rep* 257 5 and 14
- Oultram JD, Young M (1985) Conjugal transfer of plasmid pAMβ1 from *Streptococcus lactis* and *Bacillus subtilis* to *Clostridium acetobutylicum*. *FEMS Microbiol Lett* 27:129–134

- Oultram JD, Davies A, Young M (1987) Conjugal transfer of a small plasmid from *Bacillus subtilis* to *Clostridium acetobutylicum* by cointegrate formation with plasmid pAM β 1. *FEMS Microbiol Lett* 42:113–119
- Oultram JD, Loughlin M, Swinfield T-J, Brehm JK, Thompson DE, Minton NP (1988) Introduction of plasmids into whole cells of *Clostridium acetobutylicum* by electroporation. *FEMS Microbiol Lett* 56:83–88
- Oultram JD, Burr ID, Elmore MJ, Minton NP (1993) Cloning and sequence analysis of the genes encoding phosphotransbutyrylase and butyrate kinase from *Clostridium acetobutylicum* NCIMB 8052. *Gene* 131:107–112
- Owen K, Coley T (1990) Oxygenated blend components for gasoline. In: *Automotive fuels handbook*. Society of Automotive Engineers, Warrendale PA, pp 221–259
- Palosaari NR, Rogers P (1988) Purification and properties of the inducible coenzyme A-linked butyraldehyde dehydrogenase from *Clostridium acetobutylicum*. *J Bacteriol* 170:2971–2976
- Papanikolaou S, Ruiz-Sanchez P, Pariset B, Blanchard F, Fick M (2000) High production of 1,3-propanediol from industrial glycerol by a newly isolated *Clostridium butyricum* strain. *J Biotechnol* 77:191–208
- Papoutsakis ET, Meyer CL (1985) Equations and calculations of product yields and preferred pathways for butanediol and mixed-acid fermentations. *Biotechnol Bioengin* 27:50–66
- Paquet V, Croux C, Goma G, Soucaille P (1991) Purification and characterization of the extracellular α -amylase from *Clostridium acetobutylicum*. *Appl Environ Microbiol* 57:212–218
- Pedroni P, Volpe A, Galli G, Mura GM, Pratesi C, Grandi G (1995) Characterization of the locus encoding the [Ni-Fe] sulfhydrogenase from the archaeon *Pyrococcus furiosus*: evidence for a relationship to bacterial sulfite reductases. *Microbiology* 141:449–458
- Peguín S, Goma G, Delorme P, Soucaille P (1994) Metabolic flexibility of *Clostridium acetobutylicum* in response to methyl viologen addition. *Appl Microbiol Biotechnol* 42:611–616
- Peretz M, Bogin O, Tel-Or S, Cohen A, Li G, Chen J-S, Burstein Y (1997) Molecular cloning, nucleotide sequencing, and expression of genes encoding alcohol dehydrogenase from the thermophile *Thermoanaerobacter brockii* and the mesophile *Clostridium beijerinckii*. *Anaerobe* 3:259–270
- Petersen DJ, Welch RW, Rudolph FB, Bennett GN (1991) Molecular cloning of an alcohol (butanol) dehydrogenase gene cluster from *Clostridium acetobutylicum* ATCC 824. *J Bacteriol* 173:1831–1834
- Petersen DJ, Cary JW, Vanderleyden J, Bennett GN (1993) Sequence and arrangement of genes encoding enzymes of the acetone-production pathway of *Clostridium acetobutylicum* ATCC 824. *Gene* 123:93–97
- Petitdemange E, Durr C, Abbad-Andaloussi S, Raval G (1995) Fermentation of raw glycerol to 1,3-propanediol by new strains of *Clostridium butyricum*. *J Indust Microbiol* 15:498–502
- Pflugmacher U, Gottschalk G (1994) Development of an immobilized cell reactor for the production of 1,3-propanediol by *Citrobacter freundii*. *Appl Microbiol Biotechnol* 41:313–316
- Pierce SM, Wayman M (1983) Diesel fuel by fermentation of wastes. US Patent 4368056
- Potera C (1997) Genecor and DuPont create “green” polyester. *Genet Eng News* 17:17
- Prescott SC, Dunn CG (1949) The acetone-butanol fermentation. In: Prescott SC, Dunn CG (eds) *Industrial microbiology*, 2nd edn. McGraw-Hill, New York, pp 312–351
- Prescott SC, Dunn CG (1959a) The acetone-butanol fermentation. In: Prescott SC, Dunn CG (eds) *Industrial microbiology*, 3rd edn. McGraw-Hill, New York, pp 250–284
- Prescott SC, Dunn G (1959b) The acetone-ethanol fermentation. In: Prescott SC, Dunn G (eds) *Industrial microbiology*, 3rd edn. McGraw-Hill, New York, pp 295–298
- Prescott SC, Dunn CG (1959c) The butanol-isopropanol fermentation. In: Prescott SC, Dunn CG (eds) *Industrial microbiology*, 3rd edn. McGraw-Hill, New York, pp 285–294
- Qureshi N, Blaschek HP (2001) ABE production from corn: a recent economic evaluation. *J Indust Microbiol Biotechnol* 27:292–297
- Qureshi N, Lolas A, Blaschek HP (2001) Soy molasses as fermentation substrate for production of butanol using *Clostridium beijerinckii* BA101. *J Indust Microbiol Biotechnol* 26:290–295
- Rakhley G, Zhou ZH, Adams MWW, Kovacs KL (1999) Biochemical and molecular characterization of the [NiFe] hydrogenase from the hyperthermophilic archaeon, *Thermococcus litoralis*. *Eur J Biochem* 266:1158–1165
- Ramachandran KB, Goma G (1988) 2,3-Butanediol production from glucose by *Klebsiella pneumoniae* in a cell recycle system. *J Biotechnol* 9:39–46
- Rao G, Mutharasan R (1986) Alcohol production by *Clostridium acetobutylicum* induced by methyl viologen. *Biotechnol Lett* 8:893–896
- Rao G, Mutharasan R (1987) Altered electron flow in continuous cultures of *Clostridium acetobutylicum* induced by viologen dyes. *Appl Environ Microbiol* 53:1232–1235
- Rao G, Mutharasan R (1988) Altered electron flow in a reduced environment in *Clostridium acetobutylicum*. *Biotechnol Lett* 10:129–132
- Raspoet D, Pot B, De Deyn D, De Vos P, Kersters K, De Ley J (1991) Differentiation between 2,3-butanediol producing *Bacillus licheniformis* and *B. polymyxa* strains by fermentation product profiles and whole-cell protein electrophoretic patterns. *Syst Appl Microbiol* 14:1–7
- Ravagnani A, Jennert KCB, Steiner E, Grunberg R, Jefferies JR, Wilkinson SR, Young DL, Tidswell EC, Brown DP, Youngman P, Morris JG, Young M (2000) Spo0A directly controls the switch from acid to solvent production in solvent-forming clostridia. *Molec Microbiol* 37:1172–1185
- Rayner A (1926) The occurrence, properties, and uses of trimethylene glycol, and the fermentation of glycerin lyes. *J Soc Chem Indust* 45:265T–266T
- Reid SJ, Allcock ER, Jones DT, Woods DR (1983) Transformation of *Clostridium acetobutylicum* protoplasts with bacteriophage DNA. *Appl Environ Microbiol* 45:305–307
- Reimann A, Biebl H (1996) Production of 1,3-propanediol by *Clostridium butyricum* DSM 5431 and product tolerant mutants in fedbatch culture: feeding strategy for glycerol and ammonium. *Biotechnol Lett* 18:827–832
- Reimann A, Abbad-Andaloussi S, Biebl H, Petitdemange H (1998a) 1,3-propanediol formation with product-tolerant mutants of *Clostridium butyricum* DSM 5431 in continuous culture: productivity, carbon and electron flow. *J Appl Microbiol* 84:1125–1130
- Reimann A, Biebl H, Deckwer WD (1998b) Production of 1,3-propanediol by *Clostridium butyricum* in continuous culture with cell recycling. *Appl Microbiol Biotechnol* 49:359–363
- Reysset G, Sebald M (1985) Conjugal transfer of plasmid-mediated antibiotic resistance from streptococci to *Clostridium acetobutylicum*. *Ann Inst Pasteur/Microbiol* 136B:275–282
- Rogers P (1986) Genetics and biochemistry of *Clostridium* relevant to development of fermentation processes. *Adv Appl Microbiol* 31:1–60
- Rogers P (1999) Clostridia: solvent formation. In: Flickinger MC, Drew SW (eds) *Encyclopedia of bioprocess technology: fermentation, biocatalysis and bioseparation*, vol 2. Wiley, New York, pp 670–687
- Rogers P, Gottschalk G (1993) Biochemistry and regulation of acid and solvent production in clostridia. In: Woods DR (ed) *The clostridia and biotechnology*. Butterworth-Heinemann, Stoneham, pp 25–50
- Rogers P, Palosaari N (1987) *Clostridium acetobutylicum* mutants that produce butyraldehyde and altered quantities of solvents. *Appl Environ Microbiol* 53:2761–2766
- Roos JW, McLaughlin JK, Papoutsakis ET (1985) The effect of pH on nitrogen supply, cell lysis, and solvent production in fermentations of *Clostridium acetobutylicum*. *Biotechnol Bioengin* 27:681–694
- Rose N (1986) Chaim Weizmann. Penguin Books, New York
- Rosenberg SL (1980) Fermentation of pentose sugars to ethanol and other neutral products by microorganisms. *Enz Microb Technol* 2:185–193
- Ross D (1961) The acetone-butanol fermentation. *Progr Indust Microbiol* 3:71–90
- Ryden R (1958) Development of anaerobic fermentation processes: acetone-butanol. In: Steel R (ed) *Biochemical engineering*. Macmillan, New York, pp 125–148
- Sablayrolles JM, Goma G (1984) Butanediol production by *Aerobacter aerogenes* NRRL B199: effects of initial substrate concentration and aeration agitation. *Biotechnol Bioengin* 26:148–155

- Saha BC, Bothast RJ (1999) Production of 2,3-butanediol by newly isolated *Enterobacter cloacae*. *Appl Microbiol Biotechnol* 52:321–326
- Saint-Amans S, Perlot P, Goma G, Soucaille P (1994) High production of 1,3-propanediol from glycerol by *Clostridium butyricum* VPI 3266 in a simply controlled fed-batch system. *Biotechnol Lett* 16:831–836
- Sanchez-Riera F, Cameron DC, Cooney CL (1987) Influence of environmental factors in the production of R(-)-1,2-propanediol by *Clostridium thermosaccharolyticum*. *Biotechnol Lett* 9:449–454
- Sass C, Walter J, Bennett GN (1993) Isolation of mutants of *Clostridium acetobutylicum* ATCC 824. *Curr Microbiol* 26:151–154
- Sauer U, Dürre P (1995) Differential induction of genes related to solvent formation during the shift from acidogenesis to solventogenesis in continuous culture of *Clostridium acetobutylicum*. *FEMS Microbiol Lett* 125:115–120
- Schneider Z, Larsen EG, Jacobson G, Johnson BC, Pawelkiewicz J (1970) Purification and properties of glycerol dehydrase. *J Biol Chem* 245:3388–3396
- Schoutens GH, Groot WJ (1985) Economic feasibility of the production of isopropanol-butanol-ethanol fuels from whey permeate. *Process Biochem* 20:117–121
- Schoutens GH, Nieuwenhuizen MCH, Kossen NWF (1984) Butanol from whey ultrafiltrate: batch experiments with *Clostridium beijerinckii* LMD 27.6. *Appl Microbiol Biotechnol* 19:203–206
- Schoutens GH, Nieuwenhuizen MCH, Kossen NWF (1985) Continuous butanol production from whey permeate with immobilized *Clostridium beijerinckii* LMD 27.6. *Appl Microbiol Biotechnol* 21:282–286
- Schuster KC, Goodacre R, Gapes JR, Young M (2001) Degeneration of solventogenic *Clostridium* strains monitored by Fourier transform infrared spectroscopy of bacterial cells. *J Ind Microbiol Biotechnol* 27:314–321
- Seifert C, Bowien S, Gottschalk G, Daniel R (2001) Identification and expression of the genes and purification and characterization of the gene products involved in reactivation of coenzyme B12-dependent glycerol dehydratase of *Citrobacter freundii*. *Eur J Biochem* 268:2369–2378
- Seyfried M, Daniel R, Gottschalk G (1996) Cloning, sequencing, and overexpression of the genes encoding coenzyme B12-dependent glycerol dehydratase of *Citrobacter freundii*. *J Bacteriol* 178:5793–5796
- Shelley S, D'Aquino RL (1999) Three routes vie for the 1,3-propanediol market. *Chem Engin* 106:56
- Skraly FA, Lytle BL, Cameron DC (1998) Construction and characterization of a 1,3-propanediol operon. *Appl Env Microbiol* 64:98–105
- Solomon BO, Zeng AP, Biebl H, Ejiófor AO, Posten C, Deckwer WD (1994) Effects of substrate limitation on product distribution and H₂/CO₂ ratio in *Klebsiella pneumoniae* during anaerobic fermentation of glycerol. *Appl Microbiol Biotechnol* 42:222–226
- Solomon BO, Zeng A-P, Biebl H, Schlieker H, Posten C, Deckwer W-D (1995) Comparison of the energetic efficiencies of hydrogen and oxychemicals formation in *Klebsiella pneumoniae* and *Clostridium butyricum* during anaerobic growth on glycerol. *J Biotechnol* 39:107–117
- Solomons GL (1976) Solvents from carbohydrates: some economic considerations. *Process Biochem* 11:32–37
- Somrutai W, Takagi M, Yoshida T (1996) Acetone-butanol fermentation by *Clostridium aurantibutyricum* ATCC 17777 from a model medium for palm oil mill effluent. *J Ferment Bioengin* 81:543–547
- Spivey MJ (1978) The acetone/butanol/ethanol fermentation. *Process Biochem* 13:2–25
- Sprenger GA, Hammer BA, Johnson EA, Lin EC (1989) Anaerobic growth of *Escherichia coli* on glycerol by importing genes of the dha regulon from *Klebsiella pneumoniae*. *J Gen Microbiol* 135:1255–1262
- St Martin EJ, Freedberg WB, Lin ECC (1977) Kinase replacement by a dehydrogenase for *Escherichia coli* glycerol utilization. *J Bacteriol* 131:1026–1028
- Stackebrandt E, Goebel BM (1994) Taxonomic note: a place for DNA-DNA reassociation and 16S rRNA sequence analysis in the present species definition in bacteriology. *Int J Syst Bacteriol* 44:846–849
- Stephens GM, Holt RA, Gottschalk JC, Morris JG (1985) Studies on the stability of solvent production by *Clostridium acetobutylicum* in continuous culture. *J Appl Bacteriol* 59:597–605
- Stevens D, Alam S, Bajpai R (1988) Fermentation of cheese whey by a mixed culture of *Clostridium beijerinckii* and *Bacillus cereus*. *J Ind Microbiol* 3:15–19
- Stieb M, Schink B (1984) A new 3-hydroxybutyrate fermenting anaerobe, *Ilyobacter polytropus*, gen. nov.sp.nov., possessing various fermentation pathways. *Arch Microbiol* 140:139–146
- Stim-Herndon KP, Petersen DJ, Bennett GN (1995) Molecular characterization of the acetyl coenzyme A acetyltransferase (thiolase) from *Clostridium acetobutylicum* ATCC 824. *Gene* 154:81–85
- Stormer FC (1975) 2,3-Butanediol biosynthetic system in *Aerobacter aerogenes*. In: Wood WA (ed) *Methods in enzymology*, vol 41. Academic, New York, pp 518–533
- Streekstra H, Teixeira de Mattos MJ, Neijssel OM, Tempest DW (1987) Overflow metabolism during anaerobic growth of *Klebsiella aerogenes* NCTC 418 on glycerol and dihydroxyacetone in chemostat culture. *Arch Microbiol* 147:268–275
- Suzuki T, Onishi H (1968) Aerobic dissimilation of L-rhamnose and the production of L-rhamnonic acid and 1,2-propanediol by yeasts. *Agric Biol Chem* 32:888–893
- Syu MJ (2001) Biological production of 2,3-butanediol. *Appl Microbiol Biotechnol* 55:10–18
- Szmant HH (1989) *Organic building blocks of the chemical industry*. Wiley, New York, pp 347–348
- Tang JCT, Ruch FE, Lin ECC (1979) Purification and properties of a nicotinamide adenine dinucleotide-linked dehydrogenase that serves an *Escherichia coli* mutant for glycerol catabolism. *J Bacteriol* 140:182–187
- Tang JCT, Forage RG, Lin ECC (1982) Immunochemical properties of NAD⁺-linked glycerol dehydrogenases from *Escherichia coli* and *Klebsiella pneumoniae*. *J Bacteriol* 152:1169–1174
- Taylor MB, Juni E (1960) Stereoisomeric specificities of 2,3-butanediol dehydrogenases. *Biochim Biophys Acta* 39:448–457
- Terracciano JS, Kashket ER (1986) Intracellular conditions required of initiation of solvent production by *Clostridium acetobutylicum*. *Appl Environ Microbiol* 52:86–91
- Thayer A (2000) Challenges of a biobased economy C %26 EN May 29 40
- Thompson DK, Chen J-S (1990) Purification and properties of an acetoacetyl coenzyme A-reacting phosphotransbutyrylase from *Clostridium beijerinckii* (“*Clostridium butylicum*”) NRRL B593. *Appl Environ Microbiol* 56:607–613
- Thomson AW, O'Neill JG, Wilkinson JF (1976) Acetone production by methylobacteria. *Arch Microbiol* 109:243–246
- Thormann K, Feustel L, Lorenz K, Nakotte S, Dü P (2002) Control of butanol formation in *Clostridium acetobutylicum* by transcriptional activation. *J Bacteriol* 184:1966–1973
- Tobimatsu T, Hara T, Sakaguchi M, Kishimoto Y, Wada Y, Isoda M, Sakai T, Toraya T (1995) Molecular cloning, sequencing, and expression of the genes encoding adenosylcobalamin-dependent diol dehydrase of *Klebsiella oxytoca*. *J Biol Chem* 270:712–7148
- Tobimatsu T, Azuma M, Matsubara H, Takatori H, Niida T, Nishino K, Satoh H, Hayashi R, Toraya T (1996) Cloning, sequencing, and high level expression of the genes encoding adenosylcobalamin-dependent glycerol dehydrase of *Klebsiella pneumoniae*. *J Biol Chem* 271:22352–22357
- Tobimatsu T, Kjiura H, Yunoki M, Azuma M, Toraya T (1999) Identification and expression of the genes encoding a reactivating factor for adenosylcobalamin-dependent glycerol dehydratase. *J Bacteriol* 181:4110–4113
- Tong IT, Cameron DC (1992) Enhancement of 1,3-propanediol production by cofermentation in *Escherichia coli* expression *Klebsiella pneumoniae* dha regulon genes. *Appl Biochem Biotechnol* 34/35:149–159
- Tong I-T, Liao HH, Cameron DC (1991) 1,3-propanediol production by *Escherichia coli* expressing genes from the *Klebsiella pneumoniae* dha regulon. *Appl Env Microbiol* 57:3541–3546
- Toth J, Ismaiel AA, Chen J-S (1999) Purification of a coenzyme A-acylating aldehyde dehydrogenase and cloning of the structural gene from *Clostridium beijerinckii* NRRL B593. *Appl Environ Microbiol* 65:4973–4980
- Tran-Din K, Gottschalk G (1985) Formation of D(–)-1,2-propanediol and D(–)-lactate from glucose by *Clostridium sphenoides* under phosphate limitation. *Arch Microbiol* 142:87–92
- Truffaut N, Hubert J, Reyset G (1989) Construction of shuttle vectors useful for transforming *Clostridium acetobutylicum*. *FEMS Microbiol Lett* 58:15–20

- Trunger V, Boos W (1994) Mapping and cloning of *gldA*, the structural gene of the *Escherichia coli* glycerol dehydratase. *J Bacteriol* 176:1796–1800
- Tummala SB, Welker NE, Papoutsakis ET (1999) Development and characterization of a gene expression reporter system for *Clostridium acetobutylicum* ATCC 824. *Appl Environ Microbiol* 65:3793–3799
- Turner KW, Robertson AM (1979) Xylose, arabinose, and rhamnose fermentation by *Bacteroides ruminicola*. *Appl Environ Microbiol* 38:7–12
- Ui S, Masuda H, Muraki H (1983) Laboratory-scale production of 2,3-butanediol isomers (D(–), L(+), and Meso) by bacterial fermentations. *J Ferment Technol* 61:253–259
- Ui S, Masuda T, Masuda H, Muraki H (1986) Mechanism for the formation of 2,3-butanediol stereoisomers in *Bacillus polymyxa*. *J Ferment Technol* 64:481–486
- Ui S, Odagiri M, Mimura A, Kanai H, Kobayashi T, Kudo T (1996) Preparation of a chiral acetoinic compound using transgenic *Escherichia coli* expressing the 2,3-butandiol dehydrogenase gene. *J Ferment Bioeng* 81:386–389
- Ui S, Okajima Y, Mimura A, Kanai H, Kudo T (1997) Molecular generation of an *Escherichia coli* strain producing only the meso-isomer of 2,3-butanediol. *J Ferment Bioeng* 84:185–189
- Ui S, Hosaka T, Watanabe K, Mimura A (1998) Discovery of a new mechanism of 2,3-butanediol stereoisomer formation in *Bacillus cereus* YUF-4. *J Ferment Bioeng* 85:79–83
- van der Westhuizen A, Jones DT, Woods DR (1982) Autolytic activity and butanol tolerance of *Clostridium acetobutylicum*. *Appl Environ Microbiol* 44:1277–1281
- Vasconcelos I, Girbal L, Soucaille P (1994) Regulation of carbon and electron flow in *Clostridium acetobutylicum* grown in chemostat culture at neutral pH on mixtures of glucose and glycerol. *J Bacteriol* 176:1443–1450
- Verhasselt P, Poncellet F, Vits K, van Gool A, Vanderleyden J (1989) Cloning and expression of a *Clostridium acetobutylicum* α -amylase gene in *Escherichia coli*. *FEMS Microbiol Lett* 59:135–140
- Voget CE, Mignone CF, Ertola RJ (1985) Butanol production from apple pomace. *Biotechnol Lett* 7:43–46
- Voloch M, Ladisch MR, Rodwell VW, Tsao GT (1983) Reduction of acetoin to 2,3-butanediol in *Klebsiella pneumoniae*: a new model. *Biotechnol Bioengin* 25:173–183
- Wagner TO, Gray DS, Zarah BY, Kozinski AA (1980) Practicality of alcohols as motor fuel. *Alcohols as motor fuels society of automotive engineers, Warrendale PA*, pp 249–265
- Walter KA, Bennett GN, Papoutsakis ET (1992) Molecular characterization of two *Clostridium acetobutylicum* ATCC 824 butanol dehydrogenase isozyme genes. *J Bacteriol* 174:7149–7158
- Walter KA, Nair RV, Cary JW, Bennett GN, Papoutsakis ET (1993) Sequence and arrangement of two genes of the butyrate-synthesis pathway of *Clostridium acetobutylicum* ATCC 824. *Gene* 134:107–111
- Walton MT, Martin JL (1979) Production of butanol-acetone by fermentation. In: Peppler HJ, Perlman D (eds) *Microbial technology*, vol 1, 2nd edn. Academic, New York, pp 187–209
- Waterson RM, Castellino FJ, Hass GM, Hill RL (1972) Purification and characterization of crotonase from *Clostridium acetobutylicum*. *Biol Chem* 247:5266–5271
- Webster JR, Reid SJ, Jones DT, Woods DR (1981) Purification and characterization of an autolysin from *Clostridium acetobutylicum*. *Appl Environ Microbiol* 41:371–374
- Weimer PJ (1984a) Control of product formation during glucose fermentation by *Bacillus macerans*. *J Gen Microbiol* 130:103–111
- Weimer PJ (1984b) Fermentation of 6-deoxyhexoses by *Bacillus macerans*. *Appl Environ Microbiol* 47:263–267
- Weizmann C (1915) Improvements in bacterial fermentation of carbohydrates and in bacterial cultures for the same. *British Patent* 4845
- Welch RW (1991) Purification and studies of two butanol (ethanol) dehydrogenases and the effects of rifampicin and chloramphenicol on other enzymes important in the production of butyrate and butanol in *Clostridium acetobutylicum* ATCC 824. PhD thesis, Rice University, Houston TX
- Welch RW, Rudolph FB, Papoutsakis ET (1989) Purification and characterization of the NADH-dependent butanol dehydrogenase from *Clostridium acetobutylicum* (ATCC 824). *Arch Biochem Biophys* 273:309–318
- Welling H (1998) Fibers industry get ready. *Apparel Industry Magazine* 59:65–66
- Weyer ER, Rettger LF (1927) A comparative study of six different strains of the organism commonly concerned in large-scale production of butyl alcohol and acetone by the biological process. *J Bacteriol* 14:399–424
- Whitfield CD, Mayhew SG (1974) Purification and properties of electron-transferring flavoprotein from *Peptostreptococcus elsdenii*. *J Biol Chem* 249:2801–2810
- Wiesenborn DP, Rudolph FB, Papoutsakis ET (1988) Thiolase from *Clostridium acetobutylicum* ATCC 824 and its role in the synthesis of acids and solvents. *Appl Environ Microbiol* 54:2717–2722
- Wiesenborn DP, Rudolph FB, Papoutsakis ET (1989a) Coenzyme A transferase from *Clostridium acetobutylicum* ATCC 824 and its role in the uptake of acids. *Appl Environ Microbiol* 55:323–329
- Wiesenborn DP, Rudolph FB, Papoutsakis ET (1989b) Phosphotransbutyrylase from *Clostridium acetobutylicum* ATCC 824 and its role in acidogenesis. *Appl Environ Microbiol* 55:317–322
- Wilke D (1999) Chemicals from biotechnology: molecular plant genetics will challenge the chemical and the fermentation industry. *Appl Microbiol Biotechnol* 52:135–145
- Wilkinson SR, Young M (1994) Targeted integration of genes into the *Clostridium acetobutylicum* chromosome. *Microbiology* 140:89–95
- Wilkinson SR, Young M (1995) Physical map of the *Clostridium beijerinckii* (formerly *Clostridium acetobutylicum*) NCIMB 8052 chromosome. *J Bacteriol* 177:439–448
- Williams DR, Young DI, Young M (1990) Conjugative plasmid transfer from *Escherichia coli* to *Clostridium acetobutylicum*. *J Gen Microbiol* 136:819–826
- Winzer K, Lorenz K, Dü P (1997) Acetate kinase from *Clostridium acetobutylicum*: a highly specific enzyme that is actively transcribed during acidogenesis and solventogenesis. *Microbiology* 143:3279–3286
- Winzer K, Lorenz K, Zickner B, Dü P (2000) Differential regulation of two thiolase genes from *Clostridium acetobutylicum* DSM 792. *J Molec Microbiol Biotechnol* 2:531–541
- Wittlich P, Themann A, Vorlop K-D (2001) Conversion of glycerol to 1,3-propanediol by a newly isolated thermophilic strain. *Biotechnol Lett* 23:463–466
- Wood A (2001) DuPont Genencor extend alliance. *Chem Week* 163:38
- Woods DR (1995) The genetic engineering of microbial solvent production. *Trends Biotechnol* 13:259–264
- Woolley RC, Morris JG (1990) Stability of solvent production by *Clostridium acetobutylicum* in continuous culture: strain differences. *J Appl Bacteriol* 69:718–728
- Woolley RC, Pennock A, Ashton RJ, Davies A, Young M (1989) Transfer of Tn1545 and Tn916 to *Clostridium acetobutylicum*. *Plasmid* 22:169–174
- Yan R-T (1991) Enzymology of butanol formation in *Clostridium beijerinckii* NRRL B592. PhD thesis, Virginia Polytechnic Institute and State University, Blacksburg VA
- Yan R-T, Chen J-S (1990) Coenzyme A-acylating aldehyde dehydrogenase from *Clostridium beijerinckii* NRRL B592. *Appl Environ Microbiol* 56:2591–2599
- Yan R-T, Zhu C-X, Golemboski C, Chen J-S (1988) Expression of solvent-forming enzymes and onset of solvent production in batch cultures of *Clostridium beijerinckii* (“*Clostridium butylicum*”). *Appl Environ Microbiol* 54:642–648
- Yeh C-S (1955) Butanol-acetone fermentation (in Chinese). In: *Petroleum Communications China Petroleum Corporation Taiwan China December, Issue 54*, pp10–19
- Yoon K-H, Lee J-K, Kim BH (1991) Construction of a *Clostridium acetobutylicum*-*Escherichia coli* shuttle vector. *Biotechnol Lett* 13:1–6
- Yoshino S, Yoshino T, Hara S, Ogata S, Hayashida S (1990) Construction of shuttle vector plasmid between *Clostridium acetobutylicum* and *Escherichia coli*. *Agric Biol Chem* 54:437–441
- Young M, Minton NP, Staudenbauer WL (1989) Recent advances in the genetics of the clostridia. *FEMS Microbiol Rev* 63:301–326
- Youngleson JS, Santangelo JD, Jones DT, Woods DR (1988) Cloning and expression of a *Clostridium acetobutylicum* alcohol dehydrogenase gene in *Escherichia coli*. *Appl Environ Microbiol* 54:676–682

- Youngleson JS, Jones DT, Woods DR (1989) Homology between hydroxybutyryl and hydroxyacyl coenzyme A dehydrogenase enzymes from *Clostridium acetobutylicum* fermentation and vertebrate fatty acid β -oxidation pathways. *J Bacteriol* 171:6800–6807
- Youngleson JS, Lin F-P, Reid SJ, Woods DR (1995) Structure and transcription of genes within the β -hbd-adh1 region of *Clostridium acetobutylicum* P262. *FEMS Microbiol Lett* 125:185–192
- Yu P-L, Pearce LE (1986) Conjugal transfer of streptococcal antibiotic resistance plasmids into *Clostridium acetobutylicum*. *Biotechnol Lett* 8:469–474
- Yu EKC, Saddler JN (1982) Enhanced production of 2,3-butanediol by *Klebsiella pneumoniae* grown on high sugar concentrations in the presence of acetic acid. *Appl Environ Microbiol* 44:777–784
- Yu EKC, Saddler JN (1983) Fed-batch approach to production of 2,3-butanediol by *Klebsiella pneumoniae* grown on high substrate concentrations. *Appl Environ Microbiol* 46:630–635
- Yu EKC, Saddler JN (1985) Biomass conversion to butanediol by simultaneous saccharification and fermentation. *Trends Biotechnol* 3:100–104
- Yu EKC, Levitin N, Saddler JN (1982) Production of 2,3-butanediol by *Klebsiella pneumoniae* grown on acid-hydrolyzed wood hemicellulose. *Biotechnol Lett* 4:741–746
- Yu EKC, Deschatelets L, Louis-Seize G, Saddler JN (1985) Butanediol production from cellulose and hemicellulose by *Klebsiella pneumoniae* grown in sequential coculture with *Trichoderma harzianum*. *Appl Environ Microbiol* 50:924–929
- Zappe H, Jones DT, Woods DR (1986) Cloning and expression of *Clostridium acetobutylicum* endoglucanase, cellobiase and amino acid biosynthesis genes in *Escherichia coli*. *J Gen Microbiol* 132:1367–1372
- Zappe H, Jones DT, Woods DR (1987) Cloning and expression of a xylanase gene from *Clostridium acetobutylicum* P262 in *Escherichia coli*. *Appl Microbiol Biotechnol* 27:57–63
- Zappe H, Jones WA, Jones DT, Woods DR (1988) Structure of an endo- β -1,4-glucanase gene from *Clostridium acetobutylicum* P262 showing homology with endoglucanase genes from *Bacillus* spp. *Appl Environ Microbiol* 54:1289–1292
- Zeng A-P (1996) Pathway and kinetic analysis of 1,3-propanediol production from glycerol fermentation by *Clostridium butyricum*. *Bioproc Engin* 14:169–175
- Zeng A-P, Deckwer W-D (1991) A model for multiproduct-inhibited growth of *Enterobacter aerogenes* in 2,3-butanediol fermentation. *Appl Microbiol Biotechnol* 35:1–3
- Zeng A-P, Biebl H, Deckwer W-D (1990) Effect of pH and acetic acid on growth and 2,3-butanediol production of *Enterobacter aerogenes* in continuous culture. *Appl Microbiol Biotechnol* 33:485–489
- Zeng A-P, Biebl H, Schlieker H, Deckwer W-D (1993) Pathway analysis of glycerol fermentation by *Klebsiella pneumoniae*: regulation of reducing equivalent balance and product formation. *Enz Microbiol Technol* 15:770–779
- Zeng A-P, Byun T-G, Posten C, Deckwer W-D (1994a) Use of respiratory quotient as a control parameter for optimum oxygen supply and scale-up of 2,3-butanediol production under microaerobic conditions. *Biotechnol Bioengin* 44:1107–1114
- Zeng A-P, Ross A, Biebl H, Tag C, Gunzel B, Deckwer W-D (1994b) Multiple product inhibition and growth modeling of *Clostridium butyricum* and *Klebsiella pneumoniae* in glycerol fermentation. *Biotechnol Bioengin* 44:902–911
- Zeng A-P, Biebl H, Deckwer W-D (1997) Microbial conversion of glycerol to 1,3-propanediol: recent progress. In: Saha BC, Woodward J (eds) *Fuels and chemicals from biomass*. Oxford Press, Oxford UK. ACS Symposium Series 666, pp 264–279
- Zhou X, Traxler RW (1992) Enhanced butanol production and reduced autolysin activity after chloramphenicol treatment of *Clostridium acetobutylicum* ATCC 824. *Appl Microbiol Biotechnol* 37:293–297

3 Organic Acid and Solvent Production: Propionic and Butyric Acids and Ethanol

Mary Jo Zidwick¹ · Jiann-Shin Chen² · Palmer Rogers*

¹Biotechnology Development Center, Cargill, Incorporated, Minneapolis, MN, USA

²Department of Biochemistry, Virginia Polytechnic Institute and State University (Virginia Tech), Blacksburg, VA, USA

Propionic Acid and Butyric Acid	135
Introduction	135
Scientific Background	137
Propionic Acid Process	137
Butyric Acid Process	140
Commercial Applications	141
Major Uses of Propionic and Butyric Acids	141
Market Size and Prices	142
Processes for Production of Propionic and Butyric Acids	142
Research and Development	142
Improvement of Bacterial Strains	142
New Process Technologies: Propionic Acid Production	143
New Process Technologies: Butyric Acid Production	146
Propionic and Butyric Acid Production by Fermentation	147
Ethanol	148
Introduction	148
Scientific Background	149
Physicochemical Properties	149
Ethanol-Producing Microorganisms	149
Mesophilic Ethanol-Producing Bacteria	150
Thermophilic Ethanol-Producing Bacteria	152
Enzymology of Ethanol Formation	153
Pyruvate Decarboxylase	153
CoA-Acylating Aldehyde Dehydrogenase	153
Alcohol Dehydrogenase	154
Toxicity of Ethanol to Microbial Cells	155
Metabolic Engineering	156
<i>Z. mobilis</i>	156
Enteric Bacteria	157
Other Bacteria	158
Commercial Applications	158
Commercial Production	158
Nonfuel Uses	160
Fuel Ethanol	160

Research and Development of Bacterial Ethanol Production	160
Patents and Regulatory Issues	161
Prospects	162

Abstract

Both propionic acid and butyric acid together with their acid salts are incorporated into a large number of commercial products. These include food additives and flavors, preservatives, cellulose-based plastics, drug formulations, and fragrances. In the future, production of these short-chain organic acids by low-cost efficient fermentation processes also may make them attractive as feedstocks for conversion into various industrial chemicals. Ethanol is the key ingredient of alcoholic beverages, and the commercial value of the alcoholic beverages alone would make ethanolic fermentation one of the most important applications of microbial activities. Ethanol is used as an industrial chemical and as a component of healthcare and consumer products, and it is increasingly used in automobile fuel. Yeasts are commonly used in a fermentation to convert sugars into ethanol. Bacterial ethanolic fermentation is gaining importance in the development of processes to convert lignocellulosic biomass into fuel ethanol. As economic conditions and ecological considerations favor the growth of a bio-based chemical industry in the twenty-first century, fermentation-derived organic acids and ethanol will play an increasingly important role as chemical feedstocks and fuel supplement.

Propionic Acid and Butyric Acid

Introduction

Both propionic acid and butyric acid together with their acid salts are incorporated into a large number of commercial products (Boyaval and Corre 1995; Zigova and Sturdik 2000). These include food additives and flavors, preservatives, cellulose-based plastics, drug formulations, and fragrances. In the future, production of these short-chain organic acids by

*Deceased

low-cost efficient fermentation processes also may make them attractive as feedstocks for conversion into various industrial chemicals. Numerous reaction pathways are already available for conversion of lactic acid and succinic acid into useful chemicals that are potentially competitive with petroleum-based routes (Varadarajan and Miller 1999). As economic conditions favor the growth of a bio-based chemical industry in the twenty-first century, fermentation-derived organic acids will play an increasingly important role as chemical feedstocks.

At present, both propionic and butyric acids are manufactured by a number of chemical processes using petrochemical routes (Sauer 1991). For example, butyric acid is usually prepared by oxidation of butyraldehyde, which is produced from propylene by oxosynthesis (Billig and Bryant 1991). Chemical synthesis of these organic acids is favored because chemical processes are still less expensive to perform. In spite of this cost advantage, butyric and propionic acids obtained from natural sources are often required. Consumers prefer that food additives and pharmaceutical products contain ingredients of natural origin. Thus, research and development of bacterial fermentation processes yielding propionic or butyric acid has emerged during the last century. Indeed, a small number of pilot plants were designed and tested for the production of these organic acids from inexpensive biomass materials (Playne 1985). The history of these two fermentations is treated separately below.

The history of the bacterial propionic acid fermentation began from the investigations by Adolph Strecker (1854) in which he observed for the first time the formation of propionic acid from sugar. He showed that a calcium carbonate-sugar mixture, to which cheese and sour milk were added, first formed a thick, calcium-lactate slurry. Later, a second fermentation occurred in the mixture that converted the lactic acid to mostly propionic acid, some acetic acid, and a gas (later identified as carbon dioxide [CO₂]).

Pasteur (1861b, 1879) demonstrated that the phenomena of fermentation, including the butyric and propionic acid fermentations, were due to the activities of living microbes. The earliest investigations of the morphology and physiology of the propionic acid bacteria were reported by Albert Fitz (1878). From experiments using a variety of carbon sources, Fitz predicted a balanced equation for propionic acid production from organic acid and sugars:

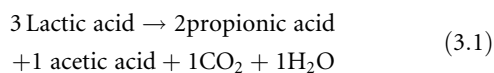

Studies by von Freudenreich and Jensen (1906) and Van Niel (1928) defined and differentiated eleven species of the *Propionibacterium* that have a role in propionic acid production during cheese making. Van Niel's thesis on the propionic acid bacteria contains extensive experimental data on growth and fermentations by these bacteria (Van Niel 1928). He demonstrated a 90–100% yield (m/m) of propionic acid during growth of a number of strains of *Propionibacterium* on glycerol. The significance of this finding is discussed (see sections [3](#) “Scientific Background” and [4](#) “Research and Development”

in this chapter). Van Niel predicted that the *Propionibacterium* fermentation might form the basis for future industrial production of propionic acid.

Research on the factors affecting the growth and fermentation by the propionic acid bacteria was published in the 1920s and 1930s and is nicely reviewed by Prescott and Dunn (1949). The early history of process development for the production of propionic acid began about the same time and has extended to the present. A detailed review of development of this process up to 1981 has been presented by Playne (1985). According to Playne (1985), Sherman and Shaw (1923) first promoted developing this fermentation into an industrial process. During the period 1920–1953, 17 patents were granted on propionic acid production by fermentation. Following this early work, three pilot-plant projects were reported which utilized sulfite waste liquors from wood pulp processing. The Wayman process (Wayman et al. 1962) was a continuous process with *Propionibacterium arabinosum* immobilized on calcium carbonate beads (>3 mm). The liquor was recycled, the pH was adjusted to above 5.7, and the operating temperature was 35–38 °C. The acids were separated by steam distillation or by solvent extraction. The designed plant would use 4,000 l/min of sulfite waste and produce 50 t of acetic and propionic acid per day. Martin et al. (1961) designed a smaller plant based on the same process in which bacterial mass was pre-grown and then immobilized in columns. With nongrowing cells, a much lower amount of yeast extract was required to maintain production and the pH tolerated was lower than pH 5.7, resulting in a higher concentration of acids during production. Utilizing the same Wayman process, Nishikawa et al. (1970) employed immobilized *Propionibacterium freudenreichii* instead of *P. arabinosum* to investigate coproduction of vitamin B₁₂ along with propionic and acetic acid after the addition of cobalt ion. Difficulties due to inhibition of growth of this strain with the sulfite liquor were reported.

The history of the butyric acid fermentation began with Pasteur's discovery that a living infusion both grew and produced butyric acid in the absence of air (Pasteur 1861a). Further, he found that the activities of these rod-shaped bodies were inhibited by exposure to air, suggesting that his bacterium was most likely a butyric clostridium. A number of scientists studied the butyric-acid fermenting bacteria during the 1880s. Beijerinck proposed that the anaerobic spore-forming microbes that were butyric fermenting could be divided into two groups: those producing mostly butyric acid or those producing mostly butyl alcohol (Morris 1993). The commercial exploitation of the acetone-butanol (AB) fermentation, which began during the First World War (1914–1918), had a great impact on the study of the anaerobic spore-forming bacteria and the history of their utilization for manufacture of chemical products (Morris 1993). The AB fermentation dependent on strains of *Clostridium acetobutylicum* dominated the market for acetone during the war and then for butanol after the war up to the early 1940s. Even with massive fermentation plants and development of downstream processing, the lower costs of chemical synthesis from petroleum became more economically competitive during

the 1950s and indeed up to the present time. There was a major attempt to produce calcium butyrate from a number of waste carbon sources including sawdust by a fermentation process developed by Lefranc and coworkers (Lefranc 1923). Employing the “Lefranc Process,” the calcium butyrate was converted downstream to dipropyl ketone by a pyrolytic process (Société Lefranc et Cie. 1925). The proposal was to use the ketones as a fuel or a fuel additive. Depasse (1945) reported a detailed description of a commercial process that would produce 5,000 l/day of ketones from beet molasses through butyrate fermentation. There is no evidence that a factory was ever built to manufacture ketones by this process (Playne 1985). Advances in strain development and in fermentation or

downstream process technology for butyric acid production have been extremely slow. In a recent short review, Zigova and Sturdik (2000) outline some of the developments since 1985 referred to below (see section “Research and Development” in this chapter).

Scientific Background

Propionic Acid Process

Table 3.1 lists the most prominent bacteria in the development of processes for propionic acid production. The

Table 3.1

Bacteria used in developing processes for propionic acid and butyric acid production

Organism	Properties
1. Propionic acid bacteria	
<i>Propionibacterium acidipropionici</i>	High yield of propionic acid
ATCC 25562, ATCC4875, P9, P68, P200910	Production strains
	Genetic development
<i>P. freudenreichii</i> subsp. <i>freudenreichii</i>	Used in Swiss-type cheese
<i>P. freudenreichii</i> subsp. <i>shermanii</i>	production
<i>P. shermanii</i>	New production strains
CDB10014, IF012426, TL162, P93, ATCC 6207 ^T	Genetic development
<i>P. thoenii</i>	Acid-tolerant strain
P20, P38, P54	Genetic studies
<i>P. jensenii</i>	Acid-tolerant strain
P114, P117	Genetic studies
<i>P. cyclohexanicum</i>	Acid-tolerant, cyclohexyl fatty
TA-12 ^T , IAM 14535 ^T	acid in membranes
	Acid-tolerant
	High lactic acid produced
<i>Clostridium propionicum</i>	Obligate anaerobe
ATCC 25522	Acrylate pathway to propionate
2. Butyric acid bacteria	
<i>Clostridium butyricum</i>	Uses many C-sources
S21	
<i>C. tyrobutyricum</i>	Selective
CIP I-776, CNRZ 596	Uses few sugars: glucose and fructose
	Produces 90 % butyrate
<i>C. beijerinckii</i>	Uses many C-sources
ATCC 25732	Will produce solvents: isopropanol, butanol, and ethanol
<i>C. acetobutylicum</i>	Uses many C-sources
ATC 4259	Will produce solvents: acetone, butanol, and ethanol
<i>Butyribacterium methylotrophicum</i>	Uses CO as a C-source

CDB Collection of the Centro de Desenvolvimento Biotecnológico, Brazil, ATCC The American Type Culture Collection, IFO The Institute for Fermentation, Osaka, HUT The Hiroshima University Type Culture Collection, P200910, P20, etc., strains from Iowa State University Collection, IAM Collection of the Institute of Applied Microbiology (now Institute of Molecular and Cellular Biosciences), Tokyo University, CIP Culture Collection of the Institut Pasteur, CNRZ Institut National de la Recherche Agronomique, and S21 Strain isolated at Slovak Technical Institute, Bratislava

propionibacteria *Propionibacterium acidipropionici*, *P. freudenreichii* subsp. *freudenreichii*, and *P. freudenreichii* subs. *P. shermanii* are the organisms used in the most recent investigations for improvement of the propionic acid fermentation.

Even though these important dairy bacteria play successful roles in Swiss-type cheese production, they suffer three major drawbacks as biocatalysts effective for commercial production of propionic acid from biomass sources. Strains of the genus *Propionibacterium* are characterized by (1) very low growth rates and fermentation rates so that a batch process would require 7–12 days to complete, (2) low tolerance to acid and to moderate concentrations of propionic or acetic acids resulting in low yields, and (3) simultaneous production of acetic acid and other products complicating downstream purification. In an attempt to allay the problem of acid sensitivity, three relatively acid-tolerant species of propionibacteria (*P. thoenii*, *P. jensenii*, and *P. cyclohexanicum*) have been investigated (▶ [Table 3.1](#)). Finally, the obligate anaerobic bacterium, *Clostridium propionicum*, is listed since it converts lactate to propionic acid, acetic acid, and CO₂, as do the propionibacteria, according to the Fitz equation (▶ [3.1](#)); see section ▶ “[Introduction](#)” in this chapter. In contrast to the propionibacteria, *C. propionicum* reduces lactate directly to propionic acid probably through an acrylate intermediate (Sinskey et al. 1981) rather than via succinate, as shown for the propionibacteria (▶ [Fig. 3.1](#)). Even though acrylic acid is an important chemical

feedstock presently produced by chemical synthesis, it is unlikely that the *C. propionicum* fermentation will develop as a bioprocess for production of this chemical (Rogers and Gottschalk 1993).

Organic acid inhibition of the propionic acid fermentation and cell growth is the most serious problem facing the use of both the propionibacteria and *C. propionicum* for any bioconversion process. Rather belatedly, research focused in this area is emerging. Batch fermentations of lactose by *P. acidipropionici* were studied at a broad pH range (4.5–7.1; Hsu and Yang 1991). As the growth rate fell from 0.23 h⁻¹ at pH 6.0–7.1 to 0.08 h⁻¹ at pH 4.5, the yield of propionic acid increased from 33 % (w/w) to about 63 % (w/w), while the yield of acetic acid was unchanged at about 9–12%. The authors also found that after growth ceased, propionic acid production continued for many hours apparently uncoupled from growth. These basic findings have led to development of improved fermentation processes; see section ▶ “[Research and Development](#).” A propionic acid-tolerant strain of *P. acidipropionici* (strain P200910) was isolated that produced significantly more propionic acid than the parent strain, P9 (Woskow and Glatz 1991). Strain P200910 contained an increase in the proportion of straight-chain fatty acids in cellular lipids. During batch and semicontinuous fermentations of whey permeate, strain P200910 showed uncoupling of propionic acid production from growth, produced a higher ratio of propionic acid to acetic acid, utilized lactose more

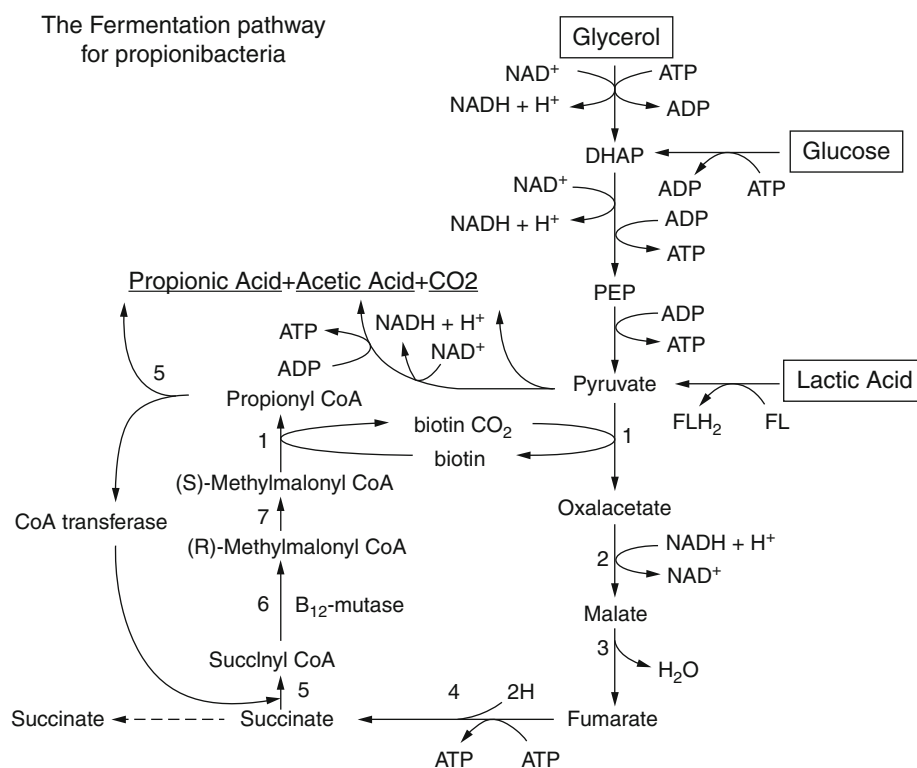

■ Fig. 3.1

Fermentation of glucose, glycerol, and lactic acid by propionibacteria utilizing the succinate-propionate pathway. 1 (S)-methylmalonyl-CoA-pyruvate transcarboxylase, 2 malate dehydrogenase; 3 fumarase, 4 fumarate reductase, 5 CoA transferase, 6 (R)-methylmalonyl-CoA mutase, and 7 methylmalonyl-CoA racemase

efficiently, and produced more propionic acid per gram of cell mass than did the parent, P9, in all fermentations. Further research is needed to determine the biochemical and genetic nature of the changes responsible for the observed superiority of acid-tolerant strains. Rehberger and Glatz (1998) tested 17 strains of propionibacteria for organic acid production after fermentation of glucose, maltose, or fructose. In general, strains of *P. acidipropionici* produced more propionic acid and reached a lower final pH than strains of other species. Strains of *P. acidipropionici*, *P. jensenii*, and *P. thoenii* were tested for ability to grow and/or survive at low pH with lactic, propionic (found to be the most inhibitory), or hydrochloric acid. The strains of *P. jensenii* and *P. thoenii* started growth and survived at a lower pH than did the *P. acidipropionici* strains. Apparently, the ability to produce large amounts of propionic acid does not coincide with the ability to initiate growth or to survive at a low pH. A newly described acid-tolerant propionibacterium, *P. cyclohexanicum*, strain TA-12, grows at pH range 3.2–7.5, whereas the closely related *P. freudenreichii* grows at pH 4.5–8.5 (Kusano et al. 1997). Strain TA-12 is also resistant to heating at 90 °C for 10 min. although it is not a sporeformer. The major cellular fatty acid was *w*-cyclohexyl undecanoic acid, which was 52.7% of the total fatty acids. It may be that the presence of this unusual lipid contributes to the acid and heat resistance of this organism. Unfortunately, following fermentation of glucose, TA-12 yielded a 5:4:2 ratio of lactic acid, propionic acid, and acetic acid (Kusano et al. 1997). These results are important for design of future experiments to determine the biological basis for acid tolerance and its relationship to acid production; see section [Research and Development](#) in this chapter.

The relationship of the propionibacteria to oxygen with respect to both growth rate and fermentation products has been examined. *Propionibacterium shermanii* CDB 10014 was reported to grow well at high oxygen (O₂) transfer rates of 24 mmoles O₂ l⁻¹ h⁻¹ (Quesada-Chanto et al. 1998b). Cell growth rate was reduced about one-third during growth on glucose in the presence of O₂, compared with anaerobic growth, whereas growth yield in the presence of O₂ increased about 50% over growth yield in anaerobic conditions. Thus, growth of propionibacteria cannot be considered O₂ sensitive. However, in contrast, growth with O₂ completely inhibits propionic acid production and enhances both acetic acid and lactic acid production by *P. shermanii* and *P. acidipropionici* (Quesada-Chanto et al. 1994b, 1998b).

Both cell growth and propionic acid production by propionibacteria are dependent upon the vitamin-nitrogen sources as well as their concentrations in the fermentation broth. Comparative experiments using various sources of yeast extract and corn steep liquor (CSL) showed slightly better growth and optimal production of propionic acid by either *P. shermanii* or *P. acidipropionici* using the less expensive CSL (Quesada-Chanto et al. 1998a).

The propionibacterium strains of the species listed in [Table 3.1](#) are rather omnivorous with respect to carbon sources for growth and acid formation. Most strains grow on

lactic acid, glycerol, and erythritol; all strains grow on a panel of sugars, and *P. thoenii* and *P. acidipropionici* grow on starch (Cummins and Johnson 1986; Kusano et al. 1997). The general fermentation pathway used by the majority of propionic acid-producing bacteria, including the propionibacteria, is the succinate-propionate pathway combined with the central pathway of carbon metabolism for conversion of glucose (sugars), lactic acid, and glycerol.

The pathway for propionic acid synthesis involves the following reactions, as first proposed by Swick and Wood (1960). Pyruvate is converted to oxaloacetate by a transcarboxylation of CO₂ from (S)-methylmalonyl-CoA by a biotin-enzyme as a CO₂-carrier. Oxaloacetate is reduced and converted to fumarate by the enzymes malate dehydrogenase and fumarase. The reduction of fumarate to succinate by a membrane-bound fumarate reductase is coupled in anaerobically grown propionibacteria to an electrochemical proton gradient sufficient to synthesize one ATP. The high growth yields of propionibacteria during fermentation are consistent with ATP formation in this reaction (Gottschalk 1986). Then succinyl-CoA is formed by transfer (catalyzed by a CoA transferase) of coenzyme A from propionyl-CoA. Rearrangement of succinyl-CoA to (R)-methylmalonyl-CoA is a coenzyme B₁₂-dependent reaction catalyzed by methylmalonyl-CoA mutase (Barker 1972). Finally, the (R)-methylmalonyl-CoA is converted to (S)-methylmalonyl-CoA by a specific racemase. The S-enantiomer is the specific substrate for the transcarboxylase yielding propionyl-CoA. The CoA transferase recycles the coenzyme A back to another succinic acid, resulting in the release of propionic acid into the broth. Thus, with the interlocking of a “one-carbon” cycle and a CoA cycle, pyruvate is reduced to propionate with a minimum expenditure of energy.

Considering the pathways for the three carbon sources displayed in [Fig. 3.1](#), under ideal conditions, the propionibacteria will produce the ratio of the three major products as well as smaller amounts of minor products such as succinic acid, lactic acid, etc., according to balance restrictions. For example, Fitz showed the usual product balance from the fermentation of lactate: 3 lactic acid = 2 propionic acid + 1 acetic acid + 1CO₂ + 1H₂O. Similarly, when glucose is fermented, the same ratio of products is usually obtained:

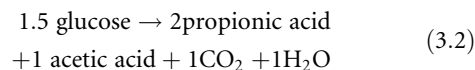

With respect to products produced, the same ratio is expected, and according to the pathways shown in [Fig. 3.1](#), the major difference is that only 3 ATPs are produced during fermentation of 3 lactic acid molecules, while 6 ATPs are expected when 1.5 glucose molecules are fermented. The maximum theoretical weight yields for sugar from the balanced [Eq. 3.2](#) are 54 % (w/w) as propionic acid and 22.2 % as acetic acid. The yield for the lactic acid fermentation ([Eq. 3.1](#)) is the same as for sugars. In a recent review, Piveteau (1999) lists a comparison of the relative amounts of propionate and acetate produced from sugars or lactate by 12 strains of

propionibacteria grown under 26 different conditions. The molar ratios, P/A, varied between 0.9/1.0 and 3.8/1.0, clustering around 2.0/1.0, as predicted from [Eqs. 3.1](#) to [3.2](#). These ratios are in contrast to that predicted and realized from the fermentation of glycerol to propionic acid. The pathway in [Fig. 3.1](#) predicts:

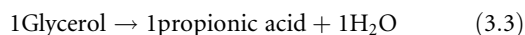

In this case, the balance does not demand any formation of CO₂ or acetic acid. Further, six ATPs are predicted when three glycerol molecules are fermented. It is interesting that Van Niel reported in his thesis (Van Niel 1928) that seven strains of propionic acid bacteria produced 90–100 % propionic acid when grown with glycerol as major carbon source. Research efforts are focusing on production of propionic acid from glycerol; see section [“Research and Development”](#) in this chapter.

Butyric Acid Process

Several bacterial species are known to produce significant amounts of butyric acid. They are members of the genera *Clostridium*, *Butyribacterium*, *Butyrivibrio*, *Eubacterium*, and *Fusobacterium*. However, it is strains of the genus *Clostridium* (Hippe et al. 1991) that have been used for development of butyric acid or butanol production ([Table 3.1](#)). The productivity of these strains is high, and they are relatively stable. In contrast to the *Propionibacterium*, they are strict anaerobes and form heat-resistant endospores. During the 1980s and 1990s, *C. butyricum* was the favored organism for the development of fermentation technologies and fermentations combined with simultaneous product recovery (Vandak et al. 1995a, b, 1997). *Clostridium butyricum* can grow well on a large number of sugars including complex mixtures, such as molasses, potato starch, and cheese-whey permeate, producing only butyric acid, acetic acid, CO₂, and H₂ in most fermentations. *Clostridium tyrobutyricum* has been studied, since fermentation of glucose yields mostly butyric acid, CO₂, and H₂ with very little acetic acid or other products. Unfortunately, natural strains of *C. tyrobutyricum* grow and ferment on only a few sugars such as glucose and fructose ([Table 3.1](#)). Both *C. acetobutylicum* and *C. beijerinckii* are important butanol-producing strains, which also synthesize primarily butyric acid under specific growth conditions (Alam et al. 1988; Evans and Wang 1990). A great deal of research effort has been centered on these bacteria, aimed at development of the butanol-acetone process; see “Butanol, Acetone, and Isopropanol” in this handbook and Rogers (1999). Because of the extensive knowledge of the regulatory system and the genetics of these organisms, they are excellent candidates for strains to be used in future development of the butyric acid process. Finally, *Butyribacterium methylotrophicum* is listed since it can grow on carbon monoxide (CO) as a sole carbon and energy source and produces primarily butyric acid under specific culture conditions (Worden et al. 1989; Shen et al. 1996). Since CO is produced by gasification of

waste biomass, it is potentially a cheap feedstock for butyric acid and acetic acid production.

The pathway for the butyric acid fermentation in the clostridia (and in fact all of the anaerobic bacteria that produce butyric acid) is illustrated in [Fig. 3.2](#).

It is clearly a branched pathway, yielding both acetic acid and butyric acid in the fermentation. As in the case of the propionic acid fermentation, this is a serious problem for downstream recovery of pure butyric acid. A second problem is that one-third of a carbon source, such as glucose, is removed as CO₂, leaving only two-thirds of the carbon for organic acid production. This loss is a consequence of the conversion of a major portion of the pyruvate produced from sugars to acetyl-CoA, CO₂, and reduced ferredoxin (FdH₂) by the enzyme pyruvate:ferredoxin oxidoreductase, which is ubiquitous in all butyrate-producing bacteria ([Fig. 3.2](#)). Reduced ferredoxin FdH₂ is reoxidized to Fd by hydrogenase which passes the two electrons to hydrogen ions yielding the H₂ gas typically produced by these organisms. The role of the butyrate branch leading from acetyl-CoA is the reoxidation of NADH to NAD⁺ so that the pathway from glucose to pyruvate can continue uninterrupted. There is also an additional ATP formed from butyryl-phosphate so that a net yield of 3ATPs for each butyrate is formed from glucose. In the alternate branch, formation of two acetic acid molecules instead of one butyric acid would not provide for reoxidation of NADH, but a net yield of 4 ATPs results from conversion of glucose to two acetic acids. Since a major characteristic of this fermentation is the simultaneous production of both butyric and acetic acid, the identification of specific control points in the bacterium that will allow selective butyric acid formation is crucial for the eventual development of a commercial process. *Clostridium butyricum* and *C. tyrobutyricum* are purely acidogenic species, and fermentation by them follows this approximate ratio of products:

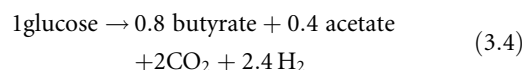

Thauer et al. (1977) have interpreted the production ratio of acetate to butyrate in terms of supplying the energy requirements in the cell. Some work has demonstrated that at high growth rates, acetate production increases, whereas at low rates of growth, butyric acid increases and acetate production either decreases or almost stops (van Andel et al. 1985; Michel-Savin et al. 1990a). These observations are consistent with the view that more acetate production results in more ATP synthesis, which would be necessary for rapid growth. Also, for every acetate molecule produced, the excess electrons are removed by the production of extra H₂ gas via hydrogenase, as shown in [Eq. 3.4](#) above. The electron traffic is apparently regulated in these cells by allosteric modification of the NADH:ferredoxin oxidoreductase and reduced ferredoxin: NAD⁺ oxidoreductase (reactions 3a and 3b, [Fig. 3.2](#)). They are sensitive to the CoA/acetyl-CoA ratio and the NAD⁺/NADH ratio, respectively (Petitdemange et al. 1976). Measurements

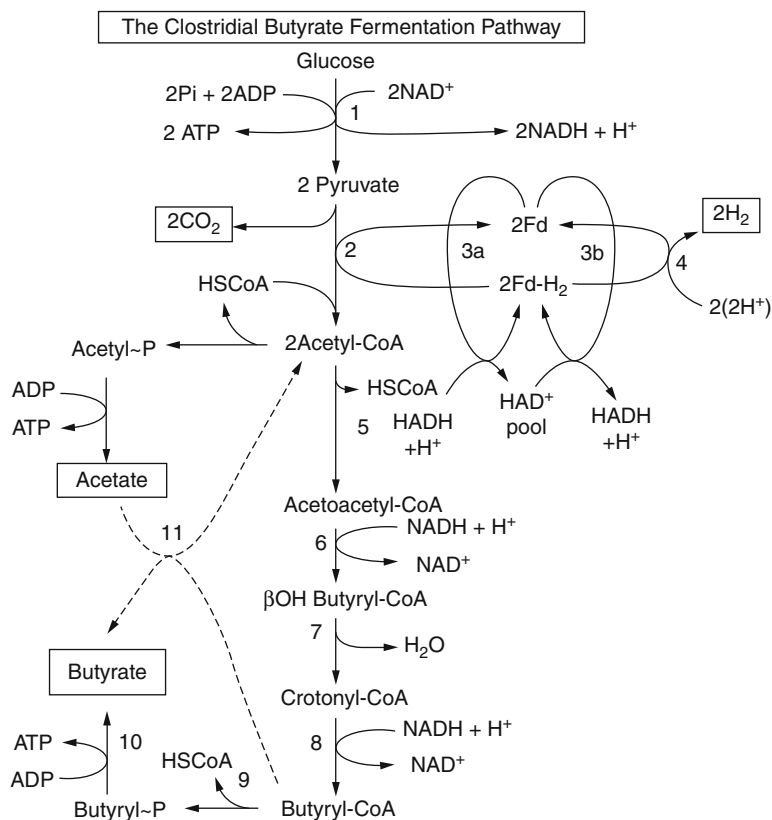

■ Fig. 3.2

The pathway of the clostridia for the formation of butyrate and acetate from glucose. 1 Embden-Meyerhof-Parnas pathway and hexose phosphotransferase, 2 pyruvate-ferredoxin oxidoreductase, 3a NAD(P)H-ferredoxin reductase, 3b ferredoxin-NAD(P)⁺ reductase, 4 hydrogenase, 5 acetyl-CoA-acetyltransferase, 6 β-hydroxybutyryl CoA dehydrogenase, 7 crotonase, 8 butyryl CoA dehydrogenase, 9 phosphotransbutyrylase, 10 butyrate kinase, and 11 proposed enzyme butyryl CoA-acetate transferase (for recycling of acetate)

of the intracellular concentrations of NADH and acetyl-CoA in *C. butyricum* at various growth rates in a glucose-limited chemostat confirm this view of the control of the butyrate-to-acetate ratio (Abbad-Andalousi et al. 1996). In all cases, the amount of acetic acid production remains lower than that of butyric acid. This is probably due to the unfavorable potential difference between the Fd/FdH₂ couple and the NAD⁺/NADH couple slowing transfer of electrons from NADH to Fd, which is essential when acetate is produced (reaction 3a, ● Fig. 3.2).

It was observed that fed-batch supply of glucose increased the productivity for butyrate by *C. tyrobutylicum*. The ratio of butyrate to acetate (selectivity) was influenced by growth rate. At high growth rates, both acetate and butyrate were produced, whereas in glucose-limited fed-batch cultures, acetate (which accumulated at high growth rates) was recycled and converted to butyrate (Michel-Savin et al. 1990a). This recycling process (probably involving a CoA transferase; ● Fig. 3.2 [dashed lines]) provides no direct energetic advantage for reutilization of acetate. The purpose of recycling in the organism may be to detoxify the medium by reducing total hydrogen ion concentration, which occurs when one butyrate substitutes for two acetates. In unlimited

glucose fed-batch cultures, *C. tyrobutylicum* produced a butyrate concentration of 42.5 g/l with a selectivity of 0.90 and a yield of 36.6 g/100 g of glucose. (Michel-Savin et al. 1990b). This unusually high selectivity may be related to recycling of acetate by these bacteria.

Commercial Applications

Major Uses of Propionic and Butyric Acids

These organic acids serve important roles in a great variety of products and industrial processes. Propionic acid and its sodium, potassium, and calcium salts are excellent antifungicides. They are used extensively in the food industry to suppress mold growth in breads, meats, fruits, and on the surfaces of cheeses and also as preservatives for grains, silage, and tobacco during storage and transport. Dipping and spraying food containers, caps, and wrappers with solutions containing propionate salts are used for preservation. Solutions of propionic acid mixed with acetic and lactic acids have been shown to be effective in growth inhibition of *Listeria monocytogenes* in foods. The Food and Drug

Administration (FDA) considers the sodium, potassium, and calcium propionate salts as safe additives (GRAS), since they are found normally in a number of foods and are metabolized easily by all mammals. Propionic acid is used in the production of cellulose-based plastics (such as cellulose acetate propionate), which are used in textiles, filters, reverse osmosis membranes, sheeting, film products, lacquers, and molding plastics. Propionic acid esters and other derivatives are used as antiarthritic and antibiotic drug preparations, as perfumes and flavors (e.g., citronellyl propionate and geranyl propionate), as plasticizers (e.g., phenyl propionate and glycerol tripropionate), and as specialized solvents.

A major use of butyric acid is in the manufacture of cellulose acetate butyrate plastics. They are used as textile fibers and in situations where resistance to heat and sunlight is essential. Calcium butyrate has been used in some leather tanning processes. Butyric acid esters are added as flavors in some soft drinks and chewing gums. Various derivatives of butyric acid are used as vasoconstrictor drugs, in anesthetics, and as antioxidants (Playne 1985).

Market Size and Prices

The main producers of propionic acid in the United States are Eastman, Hoechst Celanese, and Union Carbide (Sauer 1991). Eastman and Hoechst Celanese also manufacture butyric acid. The estimates of propionic acid production are 120×10^6 lbs/year in the United States and 80×10^6 lbs/year in Western Europe (Boyaval and Corre 1995). The price for propionic acid is currently \$1.01–1.08/kg (Anonymous 2001a). The production of butyric acid in the United States was about 48×10^6 lbs/year in 1991, and no estimate of world production is available (Sauer 1991). The price for butyric acid is not available, but the price for synthetic butyraldehyde is \$1.19–1.28/kg (Anonymous 2001b). Normally, synthetic butyric acid is produced by air oxidation of butyraldehyde (Billig and Bryant 1991). Thus, the price may be close to the price quoted for butyric acid, \$1.50/kg, in May 1982 (Playne 1985).

Processes for Production of Propionic and Butyric Acids

Chemical processes dominate the production of short-chain organic acids. The primary route of synthesis employs the “Oxo” process (Billig and Bryant 1991). Propionic acid is made by oxo synthesis of propionaldehyde from ethylene, CO, and H₂ with a rhodium catalyst. Liquid-phase oxidation of the aldehyde yields propionic acid. Butyric acid is made by air oxidation of butyraldehyde, which is synthesized by the oxo process from propylene, CO, and H₂. The triphenylphosphine-modified rhodium oxo process, termed the “LP Oxo” process, is the industry standard for the hydroformylation of ethylene and propylene (Billig and Bryant 1991). Also pure propionic acid can be obtained from propionitrile or by oxidation of propane gas.

Three changing economic forces have combined to revive a search for alternative production routes for propionic and butyric acids. The decreasing supply of world crude oil reserves will eventually increase the cost of substrates for chemical synthesis. The increasing amounts of food industry by-products and unused agricultural biomass can serve as substrates for microbial conversion. The increasing consumer demand for organic natural products in food additives, pharmaceutical products, and preservatives has produced a favorable business climate for the emergence of the microbial fermentation route for production of these organic acids. For example, organic acids produced by fermentation are favored over chemically synthesized acids when the fermentation product can be labeled a “natural preservative” for foods or feeds. Several products produced by *Propionibacterium* fermentation of milk or whey after concentration and drying have been marketed as preservatives. These include the following: Upgrade, made by Microlife Techniques; CAPARVE, produced by PTX Food Corp.; and Microgard, made by Wesman Foods, Inc. (Lyon and Glatz 1995). The United States Food and Drug Administration approved the use of Microgard in cottage cheese to prolong its shelf life, and an estimated 30 % of the cottage cheese made in the United States contains this preservative (Weber and Broich 1986).

Significant improvements in the yield, productivity, and selectivity of the fermentations producing propionic acid or butyric acid would be required if these methods were to become competitive with chemical synthesis methods used for industrial applications of these acids as commodity chemicals.

Research and Development

Improvement of Bacterial Strains

Modern genetic methods are being applied to the strains of propionibacteria that are listed in [Table 3.1](#). Lyon and Glatz (1995) have reviewed the plasmid biology, the application of DNA transfer methods, and mutagenesis and selection techniques applied to these organisms. The cryptic plasmid pRG01 is present in a number of strains of *P. acidipropionici*, *P. freudenreichii*, *P. jensenii*, and *P. thoenii*. Kiatpapan et al. (2000) sequenced this plasmid and constructed a shuttle vector, pPK705, using parts of pRG01, the *Escherichia coli* plasmid pUC18, and the hygromycin B-resistant gene as a drug marker. The pPK705 has been transferred into *P. freudenreichii* strains by electroporation at an efficiency of 8×10^6 CFU/microgram of DNA. This and other similar vectors will facilitate genetic analysis of strains of propionibacteria and allow transfer of genes for producing new industrial strains.

The solvent-forming clostridia have been the focus of a great deal of research effort over the past 20 years because of the potential to apply their ability to convert biomass into the important commodity chemicals butanol, acetone, and isopropanol. The metabolic pathways for solvent and acid production as well as the basic mechanisms of regulation of these

pathways have been determined for *C. acetobutylicum* and related clostridia (see reviews by Rogers and Gottschalk 1993, and Rogers 1999). Genetic systems for gene manipulation of the clostridia have been developed including ones involving mutagenesis (Jones 1993), conjugative gene transfer (Young 1993), clostridial cloning vectors (Minton et al. 1993), and transformation and electroporative transformation (Reyssset and Sebald 1993). With these techniques, the cloning, structure, and expression of acid and solvent pathway genes of *Clostridium acetobutylicum* have been examined in some detail (Papoutsakis and Bennett 1993; Mermelstein et al. 1994; Dürre et al. 1995). The obvious application of these basic studies is to develop clostridial strains that will be useful in processes for commercial solvent production (Papoutsakis and Bennett 1999). However, since these solventogenic organisms also produce butyric acid, strains can be developed for production of this acid as well (Alam et al. 1988; Evans and Wang 1990). Furthermore, the mechanisms of regulation of the fermentation pathways in the solvent-forming clostridia have been fairly well defined (Girbal et al. 1995a, b; Rogers 1999). Using these studies as a model, regulation of carbon and electron flow in *C. butyricum* is being examined under conditions for optimal production of butyric acid or of 1,3-propanediol (Saint-Amans et al. 2001).

The complete genome sequence of the bacterium *C. acetobutylicum* ATCC 824 was determined including a 192-kb megaplasmid that contains the majority of the genes necessary for solvent production (Nölling et al. 2001). With this information, it is now possible to effectively develop industrial strains that can be utilized for either butanol or butyric acid production from a variety of biomass sources.

A major barrier blocking commercialization of bacterial fermentation for production of propionic or butyric acid is that the available strains of propionibacteria and clostridia have low tolerance to organic acids and sensitivity to acid stress in general. The acid tolerance response (ATR) of *P. freudenreichii* was studied (Jan et al. 2000). Survival at pH 2 was conferred by preexposure of the bacteria in media at pH 4–5 so that adaptation was established within 3–10 min. Later, it was shown that new “stress” proteins are synthesized rapidly during adaptation. These proteins were identified as chaperonins GroEL and GroES. Also, specific DNA synthesis and repair enzymes were upregulated (Jan et al. 2001). However, in what way is sensitivity to accumulated organic acids related to production capacity? Rehberger and Glatz (1998) showed that *P. jensenii* and *P. thoenii* survive at a lower pH than *P. acidipropionici*, yet *P. acidipropionici* produces the highest yield (g/l) of propionic and acetic acids during fermentation. The newly described propionibacterium, *P. cyclohexanicum* (Kusano et al. 1997), grows and ferments at a low pH optimum of pH 5.5–6.5, while the pH optimum of *P. freudenreichii* and other dairy propionibacteria is 6.5–7.0. *Propionibacterium cyclohexanicum*, strain TA-12, *w*-cyclohexyl undecanoic acid is the major cellular fatty acid (52.7 % of the total fatty acids). Thus, there appears to be a number of factors governing the tolerance of propionibacteria to organic acids as well as their sensitivity to acids. The low tolerance of the clostridia to organic acids and to solvents has

been a major factor preventing their use in commercial production of acetic acid and of solvents such as butanol (see section “Acetic Acid” in Chapter 1 and section “Butanol, Acetone and Isopropanol” in Chapter 2). Although numerous mutants and so-called butanol tolerant strains of *C. acetobutylicum* and *C. beijerinckii* have been selected, this research has had only a limited impact on our understanding of tolerance or on producing industrially useful strains (Rogers 1999). On the other hand, important research has emerged on the basic elements of the general stress response and of the σ factors and the phosphorelay pathway essential for the initiation of endospore formation in *Clostridium* (Bahl et al. 1995; Sauer et al. 1995; Wilkinson et al. 1995). It was found that the transcription factor SpOA in *C. beijerinckii* not only controls entry into the sporulation cycle but also upregulates expression of genes for the solvent pathways and downregulates expression of the genes for organic acid production (Brown et al. 1994). As organic acid concentration increases and the pH drops, *C. acetobutylicum* rapidly accumulates a set of stress proteins, the chaperonins, required for proper folding of newly synthesized proteins in the bacterium; in addition, a series of ATP-dependent proteases (Lon, ClpP, and ClpX) is induced (Bahl et al. 1995). This research may be applied to the future development of organic acid-tolerant strains of the clostridia useful for commercial fermentations.

New Process Technologies: Propionic Acid Production

Comparative fermentations with a variety of substrates confirmed the earlier finding reported by Van Niel (1928) that numerous species of the propionibacteria produce propionic acid selectively with very little acetic acid when fermenting glycerol (Boyaval et al. 1994; Barbirato et al. 1997a; Himmi et al. 2000). Propionic acid/acetic acid molar ratios for *P. acidipropionici* and *P. freudenreichii* subs. *P. shermanii* were 5.7 and 3.8, respectively, with glycerol, and 1.7 and 1.3, respectively, with glucose (Himmi et al. 2000). Barbirato et al. (1997a) obtained an even better propionic acid to acetic acid ratio of 37 with *P. acidipropionici*. Since selective acid production simplifies downstream processing for recovery of propionic acid, the choice of glycerol for this process is suggested. The high proportion of acetic acid produced with glucose or lactic acid as substrate explains the lower yields of propionic acid compared to that reached when fermenting glycerol, as recorded in **Table 3.2**. Inexpensive industrial grades of glycerol are readily available as by-products of processing of natural fats and oils during production of fatty acids.

The two major weaknesses of the fermentation process for propionic acid production are the low final product concentration and the extremely low productivity due to the sensitivity of the bacterial cells to organic acids and their slow fermentation and growth rates. Two developments in fermentation technology that improve the process are the high cell density reactor and improved ultrafiltration membranes for recovery of the product.

Table 3.2
Experimental fermentation processes for production of propionic acid

Organism	Process	Substrate	Time of operation (h)	Product concentration (g l ⁻¹)	Product productivity (g l ⁻¹ h ⁻¹)	Yield for major product (g/g)	References
<i>P. acidipropionici</i> ATCC 25562	Batch	Glucose	60–80	11.9	0.17	0.59	Barbirato et al. (1997a, b, c)
		Glycerol	60–80	13.6	0.18	0.68	
		Lactic acid	60–80	12.3	0.17	0.61	
<i>P. acidipropionici</i> ATCC 4965	CSTR, high cell density, with cell recycle UF module (5 m ³ pilot plant)	Whey (lactose)	950	35	0.65	0.54–0.62	Colomban et al. (1993)
<i>P. acidipropionici</i> DSM 8250	CSTR, high cell density, with cell recycle UF module (1.5 l)	Sucrose	>336	3.0–16.2	3.0–8.0	0.4	Quesada-Chanto et al. (1994a)
		Blackstrap molasses (sugarcane)	>336	17.7	4.4	0.5	
<i>P. thoenii</i> NCDO1082	CSTR, with high cell density, cell recycle and UF module (1.5 l)	Glycerol	300	10	1.0	>0.5	Boyaval et al. (1994)
<i>P. acidipropionici</i> P200910	Immobilized cells: Ca alginate beads, 10 ¹⁰ cells per g of beads (fed batch)	Glucose	250	57	0.23	0.57	Paik and Glatz (1994)
		Corn steep liquor	250	45.6	0.18		
<i>P. thoenii</i> P20	Immobilized cells: Ca alginate beads, 2 × 10 ¹¹ cells per g of beads (repeated fed batch)	Glucose (75 g l ⁻¹)	12	34	2.8	0.45	Rickert et al. (1998)
<i>P. acidipropionici</i> ATCC4875	Immobilized cells: fibrous bed bioreactor (continuous RT 52 h)	Lactose (42 g l ⁻¹) in whey perm.	4 months	20	0.38	0.48	Yang et al. (1994)
<i>P. acidipropionici</i> and <i>S. lactis</i> OSU 588	Immobilized cells: fibrous bed bioreactor (continuous RT 68 h)	Lactose (45 g l ⁻¹) in whey perm.	4 months	22	0.32	0.49	Yang et al. (1994)
<i>P. acidipropionici</i> 4875	Hollow fiber mem. Extractive ferm. (alamine extractant)	Lactose (50 g l ⁻¹)	120	75	0.98	0.66	Jin and Yang (1998)
<i>P. thoenii</i> P20	Hollow fiber mem. Extractive ferm. (alamine extractant)	Glucose (75 g l ⁻¹)	200	71	0.4–0.6	0.5–0.6	Gu et al. (1999)
	Immobilized cells: Ca alginate beads, repeated fed batch						

CSTR continuously stirred tank reactor, UF ultrafiltration, RT room temperature, perm. permeate, ferm. fermentation, mem. membrane, and alamine, trilaurylamine

The Laboratory of Dairy Technology Research of the Institut National de la Recherche (INRA) in Rennes, France, is investigating the application of these techniques for improved propionic acid production (Boyaval and Corre 1995). Colomban et al. (1993) demonstrated the production of propionic acid from whey permeate by *P. acidipropionici* at high cell density combined with sequential cell recycling and ultrafiltration. Figure 3.3 is a diagram of the process employing a 5-m³ industrial pilot plant bioreactor.

Initially, the fermentation was run batchwise for about 100 h until the lactose concentration reached less than 5 g l⁻¹ in the bioreactor. The culture was then pumped through an ultrafiltration (UF) module to produce a permeate fraction (fermented permeate) that contained propionic and acetic acids plus

unfermented lactose (Figure 3.3). The permeate was eventually concentrated to 36 % (w/w) propionic acid and 11 % acetic acid. The retentate from the UF module containing the cell biomass and about 25 % of the culture volume was recycled back into the bioreactor together with a stream of fresh medium sufficient to replace the culture volume. Figure 3.4 presents the results of a typical run in the 5-m³ pilot plant, showing the sequential cycles of usually 70–40 h.

In a typical pilot plant run, the biomass was maintained at about 40 g dry wt l⁻¹ by partial cell bleeding (B) at the times shown during the 15 cycles for a total time of 950 h (Figure 3.4a). At this biomass density, the lactose is exhausted regularly after 50–70 h, leading to a new cycle of ultrafiltration and feeding (Figure 3.4b). During this high cell density fermentation, the

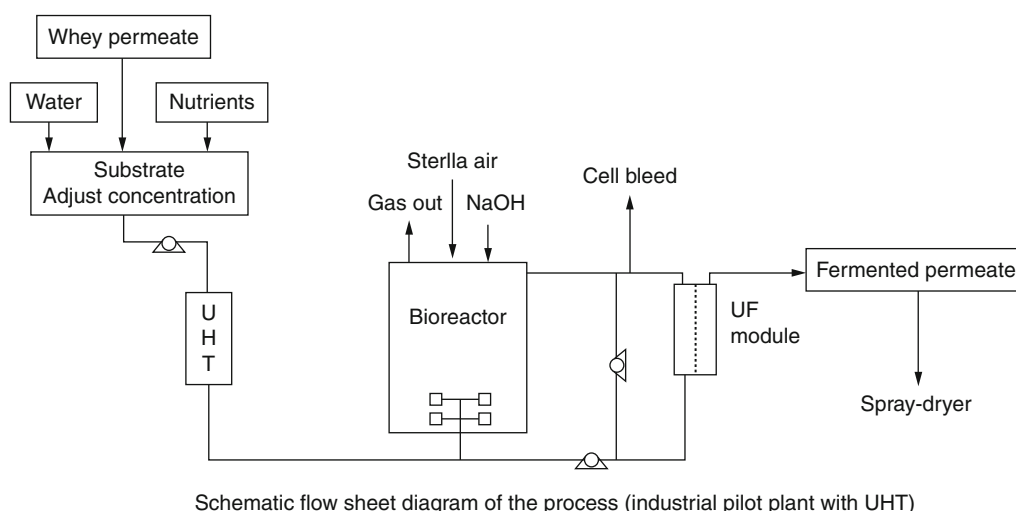

■ Fig. 3.3

Diagram of an industrial scale pilot plant for production of propionic acid from whey permeate by sequential fermentation, ultrafiltration, and cell recycling (Redrawn with permission from Colomban et al. (1993))

propionic acid and acetic acid concentrations reached were normally 35 and 9 g·l⁻¹, respectively (● Fig. 3.4c), which are three times greater than those observed in batch cultures (● Table 3.2). The productivity of propionic acid was normalized at about 0.65 g·l⁻¹ h⁻¹, which is 3.8-fold better than in batch cultures (● Table 3.2). Experimental fermentations by *P. acidipropionici* using sucrose or blackstrap molasses (cane sugar) as substrate were studied employing the same high cell density and continuous recycle process as described above (● Table 3.2). In a 1.5-l reactor, at a cell density of 125 g dry wt l⁻¹, sucrose was converted to propionic acid at the high productivity of 3.0–8.0 g·l⁻¹ h⁻¹ and at a concentration of 30–16.2 g·l⁻¹, dependent on the dilution rate (Quesada-Chanto et al. 1994a). At a cell density of 75 g dry wt l⁻¹, blackstrap molasses was fermented to propionic acid at a productivity of 4.4 g·l⁻¹ h⁻¹ and at a concentration of 17.7 g·l⁻¹. Stable production was maintained at a constant product concentration “over many weeks” (Quesada-Chanto et al. 1994a). The most encouraging report was that of the experimental fermentation of glycerol to propionic acid by *P. thoenii* NCDO 1082 by the continuous high cell density cell recycle process (Boyaval et al. 1994). During stable operation with a cell density of only 20 g dry wt l⁻¹, a propionic acid concentration of 10 g·l⁻¹ and a productivity of 1.0 g·l⁻¹ h⁻¹ were maintained, while the acetic acid concentration was only 0.1 g·l⁻¹. During the continuous ultrafiltration, the only nutrient added to the reactor was glycerol. At 140 h, a short 10-h regeneration period with yeast extract was inserted. The application of the high cell density reactor with ultrafiltration to the fermentation of glycerol as a substrate appears very promising for future development of a commercial propionic acid production process (Boyaval and Corre 1995).

Experimental fermentation processes employing cell immobilization have been applied to propionic acid production by the propionibacteria. The objectives are to create a stable high-

density cell module that will produce a high concentration of propionic acid in a relatively short time. *Propionibacterium acidipropionici* was immobilized in Ca alginate beads at about 10¹⁰ cells/g of beads. Fed-batch fermentations with 80 g of beads in 290 ml medium were incubated 250 h with either glucose or corn steep liquor as substrate (Paik and Glatz 1994). Unusually high concentrations of propionic acid were obtained: 45.6 g·l⁻¹ with corn steep liquor and 57 g·l⁻¹ with glucose (● Table 3.2). Using Ca alginate immobilized *P. thoenii* P20 at 2 × 10¹¹ cells/g of beads, Rickert et al. (1998) demonstrated complete conversion of high concentrations of glucose (65–115 g·l⁻¹) to propionic acid during a short 12-h fermentation time. For example, 75 g·l⁻¹ glucose yielded 34 g·l⁻¹ of propionic acid (● Table 3.2). A second type of immobilization technique, which appears promising, is the fibrous bed bioreactor (Lewis and Yang 1992), which consists of a piece of cotton towel (15 × 45 cm) rolled up with a stainless steel mesh and placed in a 5 × 15 cm glass column. *Propionibacterium acidipropionici* is added to the reactor with 290 ml of growth medium and incubated for 2–3 days until about 40–60 g dry wt l⁻¹ of immobilized cells is reached. Cells form a biofilm on the fiber surfaces and are entrapped in the fibrous matrix. Reactor performance was studied during continuous operation at a variety of retention times to determine the best conditions for converting the lactate or lactose in whey permeate to propionic and acetic acids (Lewis and Yang 1992; Yang et al. 1994). These reactors are capable of complete conversion of high concentrations of whey permeate-lactose to 20–22 g·l⁻¹ propionic acid at a productivity of 0.38 g·l⁻¹ h⁻¹ for 4–6 months of stable operation (● Table 3.2). Co-immobilization of *P. acidipropionici* and *S. lactis* did not improve the productivity of the fermentation (Yang et al. 1994; see ● Table 3.2). The nature of this immobilization system allows constant cell renewal, and consequently, the bioreactor could operate continuously for 6 months without clogging, degeneration, or contamination.

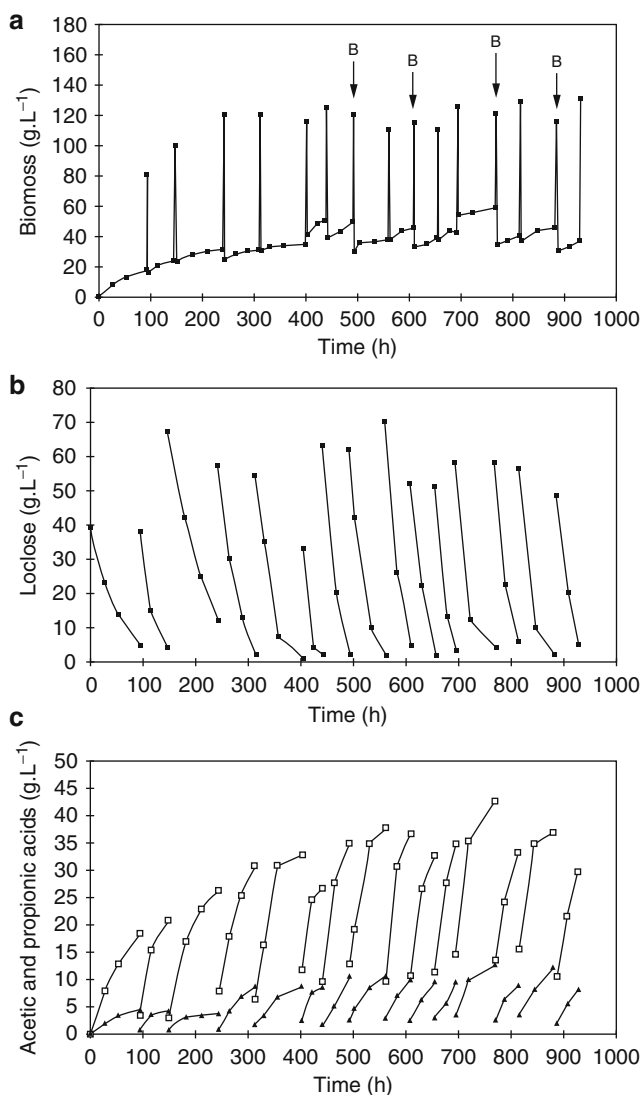

Fig. 3.4
(a) Biomass evolution during a typical run in a 5-m³ bioreactor. Each peak results from the concentration of the cells by ultrafiltration. At the times indicated by the arrows, a cell bleed, B, was done. (b) Lactose concentration during the same run. (c) Propionic acid ("box") and acetic acid ("triangle") concentrations in the same run (From Colombari et al. (1993), with permission)

Extractive fermentation is a relatively new technology that combines the fermentation process with product separation from beer. This process has been applied to commercial production of both lactic acid and ethanol, and experimental results suggest application to the propionic acid process will overcome some of the barriers indicated above. Solichien et al. (1995) examined a series of microporous membranes and polymer films for performance in membrane-based extraction of propionic and acetic acids with a range of organic solvents and acid-complexing carriers. The hollow-fiber membrane extractors, Celgard X20-400 or X-30, were found to be most satisfactory for laboratory-scale fermentations. Each extractor consisted

of 200–800 hydrophobic, microporous, polypropylene hollow fibers jacketed in an extractor shell such that the extraction solvent could flow through the hollow fibers while the fermentation broth with the cells circulated on the shell side of the extractor. Solvent leakage from the membrane pores was prevented by applying back pressure to the shell side of the extractor. The hydrophobic structure of the fibers prevented the broth from entering the solvent phase. This setup allowed the extractive fermentation to operate continuously. The solvent selected for extractive fermentation of propionic acid was 40 % Alamine 304-1 (trilaurylamine) in oleyl alcohol because it was nontoxic, provided good partitioning of propionic acid, and allowed free recovery of the acid by distillation (Gu et al. 1998, 1999). Jin and Yang (1998) used a similar extraction solvent: 4–15% adogen 283 (a secondary amine, ditridecylamine; Sherex Chemical Co., Dublin, OH) in oleyl alcohol. Jin and Yang (1998) demonstrated a fed-batch extractive fermentation of lactose by *P. acidipropionici* for propionic acid production. Lactose was added up to 50 g.l⁻¹ every 20 h, while the culture was cycled through the extractor module for 120 h. The extracted propionic acid reached 75 g.l⁻¹ at a productivity of 0.98 g.l⁻¹ h⁻¹ and a yield of 0.66 g/g of lactose (Table 3.2). This was the first report of a successful demonstration of extractive fermentation of propionic acid. Further, the fed-batch extractive fermentation produced a propionic to acetic acid ratio (P/A ratio) of 9.8, probably owing to the selectivity of the extraction step for propionic acid combined with the low pH (5.3) of the fermentation (Jin and Yang 1998). Production of propionic acid by fermentation of glucose by immobilized cells of *P. thoenii* P20 was combined with concurrent liquid extraction employing a hollow-fiber membrane extractor (Gu et al. 1999). Cells immobilized in Ca alginate beads were suspended in 300 ml broth with glucose maintained at 75 g.l⁻¹ in a fed-batch operation. The culture was continuously cycled through the shell side of the extractor with concurrent circulation of the organic extraction solvent through the tube side for more than 200 h. A total of 71 g.l⁻¹ of propionic acid and 16 g.l⁻¹ of acetic acid was produced with a propionic acid productivity varying between 0.4 and 0.6 g.l⁻¹ h⁻¹ during the fermentation (Table 3.2). Gu et al. (1999) also noted a partial selectivity of the extractive fermentation for propionic acid with a P/A ratio of 4.4.

New Process Technologies: Butyric Acid Production

The development of processes for the production of butyric acid by fermentation has centered on two species of *Clostridium*, *C. butyricum* and *C. tyrobutyricum*. Experiments employing *C. tyrobutyricum* seem the most promising primarily because strains of this bacterium are highly selective for butyric acid over acetic acid, both of which are produced simultaneously during fermentation of carbohydrates. For example, in batch culture, *C. butyricum* produces a butyric acid to acetic acid weight ratio (B/A) of 2.0–2.5, whereas the B/A for *C. tyrobutyricum* is 4.0–6.0. Thus, compared to *C. butyricum*,

■ Table 3.3

Experimental fermentation processes for production of butyric acid

Organism	Process	Substrate	Time of operation (h)	Product concentration (g·l ⁻¹)	Product productivity (g·l ⁻¹ h ⁻¹)	Yield for major product (g/g)	References
<i>Clostridium tyrobutyricum</i> CNRZ 596	Batch	Glucose	70	44	0.59	0.38	Michel-Savin et al. 1990b, c
	Continuous culture D = 0.1 h ⁻¹			16.8	1.68	0.35	
	Continuous culture D = 0.2 h ⁻¹			9.7	1.94	0.37	
	Continuous with cell recycle, UF		>400	29.7	9.5	0.45	
<i>C. tyrobutyricum</i> CIP I-776	Batch	Wheat flour hydrolysate (glucose)	140	45	0.32	0.34	Fayolle et al. 1990
	Fed batch, constant feeding		50	55.3	1.17	0.44	
	Fed batch, feeding controlled by gas production rate		50	62.8	1.25	0.45	
	Fed batch	Corn steep liquor	120	72	0.6	0.48	
<i>C. butyricum</i> S21	Batch	Glucose	30	7.3	0.24	0.24	Zigova et al. 1999
	Extractive batch	Sucrose	45	10.0	0.23	0.30	
	Pertractive fed-batch	Sucrose	95	20.0	0.21	0.19	

CIP Culture Collection of the Institut Pasteur, CNRZ Institute National de la Recherche Agronomique, S21 Strain isolated at Slovak Technical Institute, Bratislava, D dilution rate, and UF ultrafiltration

C. tyrobutyricum produces higher yields of butyrate per g of carbohydrate and higher product concentrations (see ► Table 3.3).

The most successful process reported for fermentation of glucose by *C. tyrobutyricum* was a continuous fermentation with cell recycle through a microfiltration membrane module for about 20 days (Michel-Savin et al. 1990c). With glucose fed to maintain 65 g·l⁻¹ and at a dilution rate D=0.32 h⁻¹, an excellent butyric acid concentration of 29.7 g·l⁻¹ and a remarkable productivity of 9.5 g·l⁻¹ h⁻¹ were obtained and remained constant for more than 15 days (see ► Table 3.3). Importantly, the selectivity for butyric acid production improved to a B/A ratio of 16, or 0.94 g of butyric acid per g of total acid produced. Fayolle et al. (1990) demonstrated fed-batch fermentation of wheat flour hydrolysate (glucose) or corn steep liquor by *C. tyrobutyricum* compared to batch fermentation (see ► Table 3.3). Again, productivity was greatly improved over batch fermentation, and selectivity for butyric acid reported was a B/A ratio of 10–30. The reason for the high selectivity for butyric acid observed for the *C. tyrobutyricum* fermentation may be related to the reutilization of acetate discovered by Michel-Savin et al. (1990a); see section ► “Scientific Background” in this chapter. In a very preliminary investigation, butyric acid production by *C. butyricum* was demonstrated with simultaneous extraction or pertraction of butyric acid using as an organic phase, Hostarex A327 (*n*-octyl[*n*-decyl] amine; 20% w/w in oleyl alcohol; Zigova et al. 1999). They reported an increase in butyric acid concentration compared

to the control batch fermentation with either integrated extraction or pertraction during the fermentation (see ► Table 3.3).

Final recovery and purification of organic acids from the fermentation broth is the most energy-intensive and costly stage in any bulk manufacturing process. Experiments using the modern solvents for simultaneous extraction during the fermentations of propionic or butyric acid resulted in rather low concentrations of organic acids (50–70 g·l⁻¹), as shown in ► Tables 3.2 and ► 3.3. Thus, further separation steps would be necessary. Playne (1985) reviewed nine different approaches to the problem of separation of organic acids available at that time, with no real solution. Boyaval et al. (1993) demonstrated the application of electrodialysis with bipolar membranes and electro-electrodialysis for concentration of propionic acid up to 130 g·l⁻¹ from fermentation broth with 40 g·l⁻¹. Boyaval and Corre (1995) propose that this technique considerably improves the recovery and purification step, but it had not been evaluated for an industrial process at that time.

Propionic and Butyric Acid Production by Fermentation

Today, chemical synthesis of propionic and butyric acids dominates the production of these and most other organic acids used in industry. However, since these organic acids are added to products for human consumption by both the food and pharmaceutical industries, consumer demand for “natural sources”

of these acids is substantial. Thus, fermentation can play a role in supplying these markets. The prospect of future challenge of the dominant chemical methods by fermentation technology will depend upon decreased availability and increasing cost of ethylene, propylene, or other chemical precursors.

Developments of the propionic acid fermentation catalyzed by propionibacteria are outlined above (see section [“Areas of Research and Development”](#) in this chapter). First, selectivity for propionic acid was improved to better than 95 % of total organic acids by using glycerol as a carbon source. Low-cost industrial-grade glycerol is available and is used in production of 1,3-propanediol by *C. butyricum* (Papanikolaou et al. 2000). Secondly, the research laboratories at INRA, France, combined new production technologies to demonstrate an economical production of propionic acid from cheese whey with propionibacteria (Colomban et al. 1993). Downstream processing with electro dialysis membrane modules facilitated recovery and purification from the fermentation medium (Boyaval et al. 1993). A second approach is the simultaneous extractive fermentation, using a hollow fiber membrane module and an amine extractant to keep the organic acid concentration in the growth medium low and to recover the propionic acid in a separate solution (Jin and Yang 1998; Gu et al. 1999). Although this experimental work appears promising, these new technologies have yet to reach a commercial production stage.

Work on fermentation processes yielding butyric acid is not as advanced as that for propionic acid. *Clostridium tyrobutyricum* was found superior to *C. butyricum* in that *C. tyrobutyricum* is more selective, yielding 90% of total organic acids as butyric acid. Some preliminary studies gave high productivities and product concentrations (Fayolle et al. 1990; Michel-Savin et al. 1990c). Unfortunately, this clostridium will grow and ferment only glucose and fructose as carbon sources. However, there is every reason to be optimistic about the future of this fermentation for two reasons. First, a great deal of genetic and physiologic work on the closely related butanol-producing strains such as *C. acetobutylicum* has been done (see section [“Areas of Research and Development”](#) in this chapter). Thus, the panel of carbon sources available to *C. tyrobutyricum* can be changed easily. Secondly, fermentation processes for the production of 1,3-propanediol have been greatly developed (see “1,3- and 1,2-propanediols” in Butanol, Acetone, and Isopropanol in this handbook). The methods developed for production of 1,3-propanediol, employing strains of *C. butyricum*, will certainly be applicable to developing processes for butyric acid production (Papanikolaou et al. 2000).

Ethanol

Introduction

Among alcohols, ethanol is the best known because it is the intoxicating ingredient of alcoholic beverages, which mankind has consumed since ancient times. The use of fermentation to convert starchy or sugary material into ethanol-containing

liquid is thus among the earliest practices of applied microbiology. It has been suggested that alcoholic fermentation played a role in making water potable where other methods for the treatment of water were not available. The commercial value of the alcoholic beverages alone would rank ethanolic fermentation (for the production of wine and spirits) as one of the most important applications of microbial activities.

Despite the long practice of ethanolic fermentation by mankind, the active agent for this process was not known until the mid-nineteenth century. In the 1830s, after the successful synthesis of urea from inorganic materials, chemists debated intensely the subject of whether ethanol is a product of biological action. That yeast is the agent responsible for ethanol production in sugary liquid was eventually established by Louis Pasteur (1822–1895). Since the discovery of anaerobic bacteria by Pasteur, the number of known mesophilic ethanol-producing bacteria has been rising continuously. During the past 20 years, many saccharolytic thermophilic anaerobic bacteria have been isolated, and some of them can produce ethanol from hexoses and pentoses with a high yield (see section [“Ethanol-Producing Microorganisms”](#) in this chapter).

Among ethanol-producing bacteria, *Zymomonas mobilis* is unusual in having an ethanol productivity higher than that of the yeast *Saccharomyces cerevisiae* and an ethanol tolerance comparable to that of the yeast (Buchholz et al. 1987). However, the substrate range of *Z. mobilis* is as limited as the yeast's. The high ethanol productivity of *Z. mobilis* is partly attributable to the high levels of pyruvate decarboxylase and alcohol dehydrogenase in *Z. mobilis*. This property has been utilized in the engineering (see section [“Metabolic Engineering”](#) in this chapter) of *Z. mobilis*, *Escherichia coli*, *Klebsiella oxytoca*, and other bacteria to create strains that can produce high yields of ethanol from all sugars that are monomers of hemicellulose and cellulose.

Ethanol has many uses. Besides being the key ingredient of alcoholic beverages, ethanol is traditionally used as an industrial chemical and as a component of pharmaceuticals and other healthcare and consumer products. As a chemical, ethanol can be produced either through chemical synthesis or by fermentation. Owing to changes in the availability and cost of the raw materials and the needs of the market, the major route for ethanol production has changed back and forth between fermentation and chemical synthesis since the 1930s. In the United States, synthetic ethanol began to dominate the market in the 1950s, and the trend continued until the early 1980s when fermentation again became the major route (see section [“Commercial Production”](#) in this chapter). At present, the United States production of fermentation ethanol at over 1.6 billion gal a year has greatly exceeded previous levels achieved by the synthetic route. In Brazil, over 3.6 billion gal of fermentation ethanol were produced during the 1997–1998 harvest (Zanin et al. 2000). This dramatic increase in ethanol production is because of the use of ethanol as an automobile fuel, which results from the jump in oil prices in the early 1970s and from the uncertainty of an unobstructed supply of crude oil. Ethanol has been used as a fuel for various purposes, and its use as an

automobile fuel also has a long history (Jackson and Moyer 1991). However, the extensive use of ethanol (as an automobile fuel) did not start until the implementation of the Brazilian National Alcohol Program (the Pro-Alcohol Program) in 1975 (Jackson and Moyer 1991; Zanin et al. 2000).

Fermentation ethanol has traditionally been produced by using yeasts with sugars from corn, sugar beet, and sugarcane juice as the raw material. During the past 20 years, great advances have been made in the development of a bacterial process for the production of ethanol from lignocellulosic biomass (Sheehan 2000). A commercial plant is under construction to use an engineered strain of *E. coli* to produce 20 million gal of ethanol per year from sugarcane residues and rice hull (see section [▶ “Commercial Production”](#)). Further improvement of bacteria for the commercial production of ethanol from lignocellulosic materials should increase the proportion of ethanol produced by bacteria.

Fermentation ethanol that is produced from the lignocellulosic biomass has been identified as bioethanol, to distinguish it from ethanol produced from feed grains. Lignocellulosic materials represent the bulk of plant biomass and are a desirable source of energy because they are less expensive to produce than grains and are not used for food or feed. When taking into consideration the use of fuel through all stages of production, producing ethanol from lignocellulosic biomass requires much less fossil fuel than producing ethanol from feed grains. Up to 7 gal of oil may be needed to produce 8 gal of ethanol from feed grains, whereas only about one gal of oil is needed to produce 7 gal of ethanol from cellulosic biomass (Lugar and Woolsey 1999). Comprehensive reviews on the technology, economics, and policy issues of bioethanol production by bacterial fermentation are available (Himmel et al. 1997; Sheehan 2000; Wyman 2001).

Scientific Background

Physicochemical Properties

Ethanol or ethyl alcohol ($\text{CH}_3\text{CH}_2\text{OH}$, mol. wt. 46.07) is a colorless, flammable liquid. Anhydrous ethanol has a boiling point of 78.5 °C and is hygroscopic. It has a specific gravity of 0.7893 at 20 °C (relative to water at 4 °C), or a weight of 6.578 lb (20 °C) per gallon. Ethanol and water form an azeotrope, which has an ethanol concentration of 95.57% (by weight), 94.9% (by volume), or 92.3% (by weight of ethanol at 15.56 °C). The azeotropic mixture has a boiling point of 78.15 °C. Therefore, distillation of a fermentation broth yields the “95%” ethanol, which must be further processed to yield the anhydrous ethanol. The 95% ethanol can be used directly as a fuel for automobiles equipped with a specially designed engine (Jackson and Moyer 1991; Zanin et al. 2000). However, anhydrous ethanol must be used when it is blended with gasoline.

After 1975, a major use for ethanol was as a fuel or fuel additive for automobiles (see section [▶ “Commercial Applications”](#) in this chapter). Ethanol has a number of desirable properties when used as a fuel in an internal combustion engine

(Winston 1981; Jackson and Moyer 1991). These desirable properties include the following: (1) high heat of combustion relative to volume. Ethanol has a heating value of 11,500–12,800 British thermal units (Btu)/lb, which is about two-thirds that of gasoline (18,900–20,260 Btu/lb). (2) High rate of flame propagation. The rate of flame propagation of ethanol is roughly comparable to that of gasoline. A high rate of propagation is important because the fuel in the combustion chamber must burn completely during the combustion stroke or it is blown out in the exhaust stroke without doing useful work. (3) High octane rating. The octane rating measures the relative tendency of fuels to pre-ignite, which is an undesirable property, when a mixture of fuel and air is compressed on the second stroke in an automobile (Otto cycle) engine. *Iso*-octane was chosen as a standard and assigned an octane rating of 100. Fuels that burn less readily than *iso*-octane are assigned octane ratings higher than 100. Ethanol has a Research Octane Number (RON) of 106 and a Motor Octane Number (MON) of 92. In comparison, “straight run” gasolines have RON and MON ranging as low as 80s and 60s, respectively. Gasoline sold as an automobile fuel in the United States generally has an octane rating between 87 and 93, which is based on $(\text{RON} + \text{MON})/2$. Ethanol is therefore an effective octane-rating enhancer for gasoline and is a substitute for MTBE (methyl *tert*-butyl ether), which replaces the lead-based octane-rating enhancer in gasoline; however, use of MTBE in the United States is now being phased out because of its threat to the environment (Houge 2000).

Ethanol has an oxygen content of 35 % (on a weight basis) and is hence also described as an oxygenate when used as a fuel additive. When blended with gasoline, ethanol can improve the combustion of fuel in the automobile engine to reduce the amount of carbon monoxide in the exhaust gas (Sheehan 2000). Therefore, besides its usefulness as an octane-rating enhancer, ethanol has been blended with gasoline to be used in regions where carbon monoxide emission from automobiles is a problem, especially in cold climate.

Ethanol-Producing Microorganisms

Ethanol, a product of anaerobic metabolism, is produced by a wide range of eukaryotic and prokaryotic microorganisms when growth or redox metabolism takes place under oxygen-free or low-oxygen conditions (Wiegel 1980). Because alcohol dehydrogenases (see section [▶ “Toxicity of Ethanol to Microbial Cells”](#)) catalyze a readily reversible reaction, it is natural for short-term ethanol production to occur when the intracellular condition favors the formation of ethanol. Thus, even obligate aerobic bacteria like *Pseudomonas* and *Alcaligenes* can produce ethanol if they are incubated under anaerobic conditions (Vollbrecht and El Nawawy 1980). In general, however, ethanol is a product of obligate and facultative anaerobes, including *Bacillus subtilis* (Nakano et al. 1997), which may produce ethanol when grown under anaerobic conditions in the absence of external electron acceptors.

Among ethanol-producing microorganisms, the yeast *Saccharomyces cerevisiae* is the best known, and it is still the most widely used organism for the production of industrial ethanol from glucose (from corn) and sucrose (from sugarcane or sugar beet). *Saccharomyces cerevisiae* can metabolize glucose, fructose, galactose, maltose, and sucrose, but not starch or other polysaccharides (Helbert 1982). The lager beer yeast *Saccharomyces uvarum* is sometimes used because it is more flocculent and sediments faster than *S. cerevisiae* (Reed 1982). In addition to *S. cerevisiae* and *S. uvarum*, other ethanol-producing yeasts are used to ferment raw materials containing sugars not efficiently used by *S. cerevisiae* (Reed 1982). *Candida utilis* is used for the fermentation of the sulfite liquor (waste from the paper industry) because it also ferments pentoses. The fermentation of whey (waste from cheese making) requires the use of a “dairy” yeast, such as *Kluyveromyces fragilis* and *Kluyveromyces lactis*, because the dairy yeasts can ferment lactose at a rate comparable to that of glucose utilization by *S. cerevisiae*. Besides yeasts, several other fungi within the genera of *Aspergillus*, *Fusarium*, and *Penicillium* can produce more than a mole of ethanol per mole of glucose consumed, but these fungi do not grow or metabolize sugars as fast as yeasts or bacteria do (Wiegel 1980).

Many bacteria have the ability to produce ethanol, but relatively few taxa contain bacteria that produce ethanol as a major end product. Ethanol-producing species can be found among aerobic, anaerobic, and facultative anaerobic bacteria within the family Enterobacteriaceae and the genera *Bacillus*, *Bacteroides*, *Bifidobacterium*, *Clostridium*, *Eubacterium*, *Lactobacillus*, and many others (Wiegel 1980). Examples of mesophilic (▶ Table 3.4) and thermophilic (▶ Table 3.5) bacteria that can produce one or more moles of ethanol per mole of glucose metabolized have been compiled by Wiegel (Wiegel 1980, 1992).

Mesophilic Ethanol-Producing Bacteria

Several mesophilic species are potentially useful for the production of industrial or fuel ethanol. Among them, the facultative anaerobes *Escherichia coli* and *Zymomonas mobilis* have been extensively investigated. The metabolic capabilities of *E. coli* (Ingram et al. 1998, 1999) and *Z. mobilis* (Zhang et al. 1995) have been expanded by genetic manipulations to enable these species to produce ethanol efficiently from sugars derived from hemicellulosic materials (see section ◉ “Metabolic Engineering” in this chapter). Besides the sugar-fermenting species, the CO-utilizing *Butyrivacterium methylothrophicum* (Worden et al. 1991), *Clostridium ljungdahlii* (Tanner et al. 1993), and *Clostridium autoethanogenum* (Abrini et al. 1994) can produce ethanol from synthesis gas (CO plus H₂), which may be derived by gasification of biomass (Klasson et al. 1992; Philips et al. 1994; Clausen and Gaddy 1996) or coal (Barik et al. 1988). Members of the genus *Acetobacterium*, including *Acetobacterium woodii*, *Acetobacterium carbinolicum*, and *Acetobacterium wieringae*, which do not normally produce ethanol from glucose and CO₂, shift their metabolism to produce ethanol when the phosphate concentration of the growth medium is below a certain level (Buschhorn et al. 1989). The amount of ethanol produced by *A. woodii* is moderate (below 15 mM), but its production of ethanol in the stationary phase when there is an excess of glucose or fructose in the medium and when the phosphate concentration is low (below 8.4 mM) suggests an interesting regulatory mechanism. In addition, growth of *A. woodii* can tolerate an ethanol concentration up to 1 M (4.6%, w/v), which is unusual among bacteria (Buschhorn et al. 1989). Properties of extensively investigated mesophilic ethanol-producing bacteria are described below.

■ **Table 3.4**
Mesophilic bacterial species producing ethanol as a major end product

Organism	Moles of ethanol produced per mole of glucose metabolized
<i>Clostridium sporogenes</i>	Up to 4.15 ^a
<i>Clostridium indolis</i> (pathogenic)	1.96 ^a
<i>Clostridium sphenoides</i>	1.8 ^a (1.8) ^b
<i>Clostridium sordellii</i> (pathogenic)	1.7
<i>Zymomonas mobilis</i> (syn. Z. anaerobica)	1.9
<i>Zymomonas mobilis</i> subsp. pomaceae	1.7
<i>Spirochaeta aurantia</i>	1.5 (0.8)
<i>Spirochaeta stenostrepta</i>	0.84 (1.46)
<i>Spirochaeta litoralis</i>	1.1 (1.4)
<i>Erwinia amylovora</i>	1.2
<i>Leuconostoc mesenteroides</i>	1.1
<i>Streptococcus lactis</i>	1.0
<i>Sarcina ventriculi</i> (syn. Zymosarcina)	1.0

^aIn the presence of high amounts of yeast extract

^bValues in parentheses were obtained with resting cells

Adapted from Wiegel (1980)

■ Table 3.5
Thermophilic bacterial species producing ethanol as a major end product

Organism	T _{max}	Moles of ethanol produced per mole of glucose metabolized
<i>Thermoanaerobacter tengcongensis</i> ^a	80	0.7
<i>Thermoanaerobacter ethanolicus</i>	78	1.8; 1.4 (xylose)
<i>Thermoanaerobacter thermohydrosulfuricus</i> (formerly <i>Clostridium thermohydrosulfuricum</i>) ^b	78	12–1.5
<i>Bacillus stearothermophilus</i>	78	1.0 (anaerobic, above 55 °C)
<i>Thermoanaerobacter brockii</i> subsp. brockii (formerly <i>Thermoanaerobium brockii</i>) ^{b,c}	78	0.95
<i>Thermoanaerobacter brockii</i> subsp. finnii (formerly <i>Thermoanaerobacter finnii</i>) ^{c,d}	75	1.67; 1.26 (xylose)
<i>Thermoanaerobacter mathranii</i> ^e	75	1.1 (xylose)
<i>Clostridium</i> sp. (cellulolytic)	75	0.8
<i>Thermoanaerobacterium thermosaccharolyticum</i> (formerly <i>Clostridium thermosaccharolyticum</i>) ^f	68	1.1
<i>Clostridium thermocellum</i>	68	1.0

^aXue et al. (2001)

^bLee et al. (1993)

^cCayol et al. (1995)

^dWiegel (1992)

^eLarsen et al. (1997)

^fCollins et al. (1994) and Cann et al. (2001)

Adapted from Wiegel (1980), with the addition of new data

Zymomonas mobilis is a remarkable ethanol producer (Swings and De Ley 1977; Rogers et al. 1982). It is one of the natural fermentative agents in the production of palm and cactus wines and the Mexican drink “pulque” and has been isolated from various fermenting, sugar-rich fluids (Rogers et al. 1982). About 20 different names have been used for this organism since its original naming as “*Termobacterium mobile*”; the names and the history have been reviewed (Swings and De Ley 1977). *Zymomonas mobilis* is a facultative anaerobic rod (some strains are obligately anaerobic, whereas others can tolerate some O₂). It can produce almost two moles of ethanol and two moles of CO₂ from each mole of glucose or fructose metabolized. Some strains can also ferment sucrose, but no other carbon sources are used. *Zymomonas mobilis* is the only species in the genus (Swings and De Ley 1984). It is excluded from the Enterobacteriaceae on the basis of its polar flagellation, its inability to reduce nitrates, its growth at pH 4, and its growth in the presence of 5% ethanol. Genetically, phenotypically, and ecologically, *Zymomonas* is related to the acetic acid bacteria, especially *Gluconobacter*: they both occur in acidic, sugary, and alcoholic niches such as tropical plant juices and beer (Buchholz et al. 1987).

Zymomonas mobilis can produce ethanol to a concentration of 10–12%, which is comparable to the performance of the yeasts *S. cerevisiae* (Buchholz et al. 1987) and *S. uvarum* (Kosaric 1996). Compared with the yeasts, the bacterium *Z. mobilis* has higher rates (twofold or greater) of sugar uptake and ethanol production. It converts sugar to ethanol with a similar yield (above 90%) and tolerates high sugar concentrations

(above 40%). *Zymomonas mobilis* ferments sugars exclusively via the Entner-Doudoroff pathway. The key intermediate of the Entner-Doudoroff pathway, 2-keto-3-deoxy-6-phosphogluconate (KDPG), is cleaved by KDPG aldolase to pyruvate and glyceraldehyde-3-phosphate, and the latter is further metabolized to pyruvate. Thus, two moles of pyruvate are produced per mole of glucose, but only one mole of ATP is obtained per mole of glucose consumed. *Zymomonas mobilis* uses pyruvate decarboxylase (PDC) to convert pyruvate directly to acetaldehyde and CO₂, whereas most other ethanol-producing organisms convert pyruvate to acetyl-CoA and CO₂ first and require an acetaldehyde dehydrogenase to convert acetyl-CoA to acetaldehyde, the substrate for alcohol dehydrogenase (ADH). The high ethanol productivity of *Z. mobilis* is correlated with the organism’s high cellular level of PDC and ADH.

Under anaerobic growth conditions, *Escherichia*, *Klebsiella*, and other enteric bacteria produce ethanol as a minor end product (Gottschalk 1986). The native ethanol productivity of these bacteria is not useful for industrial applications. However, the enteric bacteria can ferment hexose as well as pentose sugars derived from hemicellulosic materials (Ingram and Doran 1995). To take advantage of their broad substrate range, the enteric bacteria have been recipients of the *Z. mobilis* PDC and ADH genes, and recombinant strains of *E. coli* will be used in the commercial production of fuel ethanol (see section “Metabolic Engineering” in this chapter).

In addition to the organisms that convert carbohydrates into ethanol, there are mesophilic anaerobic bacteria that can convert CO into ethanol. A strain of *Butyribacterium methylotrophicum*

that was adapted to grow on 100 % CO (with a doubling time of 12 h) produced small amounts of butanol and ethanol (Grethlein et al. 1990; Worden et al. 1991). Ethanol production in a continuous culture doubled (from 0.026 to 0.056 g/l) when the pH decreased from 6.8 to 6.0 (Grethlein et al. 1990). *Clostridium autoethanogenum* is another anaerobe that can grow on 100 % CO and produce ethanol besides acetate and CO₂ (Abrini et al. 1994). *Clostridium autoethanogenum* was isolated from rabbit feces, which is known to contain active CO-utilizing bacteria. Besides 100 % CO, this organism can also grow on CO₂ plus H₂, pyruvate, arabinose, xylose, fructose, rhamnose, and L-glutamate. From chicken yard waste, another CO-utilizing anaerobe, *Clostridium ljungdahlii*, was isolated (Barik et al. 1988; Vega et al. 1989; Tanner et al. 1993). *Clostridium ljungdahlii* can grow on CO, CO₂ plus H₂, ethanol, pyruvate, arabinose, xylose, fructose, or glucose. The amount of ethanol produced by *C. ljungdahlii* was low initially (Klasson et al. 1992), but the productivity increased in response to changes in growth conditions (Philips et al. 1994). By maintaining the pH at 4–4.5 and using a nutrient-limited medium, the ethanol concentration was raised to 20 g/l, whereas the acetate concentration was lowered to 2–3 g/l (Clausen and Gaddy 1996). Ethanol production from CO and H₂ (synthesis gas) has a low volumetric productivity, which is attributed to low cell densities, production of unwanted by-products, and slow transfer of the gases into the liquid phase (Worden et al. 1997). These engineering and biological problems will need to be resolved before synthesis gas, which may be generated through gasification of coal or cellulosic materials, can be biologically converted into ethanol on a commercial scale.

Thermophilic Ethanol-Producing Bacteria

Thermophilic bacteria have been proposed for the production of useful chemicals (Wiegel and Ljungdahl 1986; Slapack et al. 1987; Lynd 1989; Wiegel 1992; Lowe et al. 1993). Wiegel (1980) listed seven advantages of using thermophilic anaerobic bacteria for ethanol fermentation. They include higher ethanol yields due to the utilization of a wide range of substrates as well as less biomass production (relative to aerobes), fast fermentation, little or no possibility for microbial contamination, no need for aeration or cooling, and a growth condition conducive to continuous distillation for the removal of ethanol and other volatile products. Commercial utilization of the thermophiles for ethanol production will be more attractive when genetic tools for engineering these organisms are further developed.

Ethanol-producing thermophiles are members of the genera *Clostridium*, *Thermoanaerobacterium*, and *Thermoanaerobacter*. The latter two genera include several species that were at first identified as members of the genus *Clostridium* (Wiegel 1992; Lee et al. 1993). The first thermophilic anaerobe that is still validly described (being included in the Approved Lists of Bacterial Names) is the cellulose-degrading, ethanol-producing *Clostridium thermocellum*; however, it took nearly 20 years after its first description before a pure culture was obtained

(Wiegel 1992). In early 2001, there are over 20 named species in the two genera *Thermoanaerobacterium* and *Thermoanaerobacter*. A taxonomic key was proposed for the preliminary identification of saccharolytic, ethanol-producing, thermophilic anaerobic bacteria (Lee et al. 1993). However, the description for the genus *Thermoanaerobacterium* has been emended concerning the location of sulfur droplets (Liu et al. 1996) or the lack of reduction of thiosulfate to sulfur (Cann et al. 2001). The lack of defining phenotypic characteristics for some species makes their assignment to a proper genus difficult. Therefore, the following taxonomic key may be revised when useful criteria for further differentiation emerge:

- A. Does not reduce thiosulfate, ferments cellulose
 1. *Clostridium thermocellum* (Wiegel 1992)
- B. Does reduce thiosulfate, does not ferment cellulose
 1. May reduce thiosulfate to elemental sulfur
 - Thermoanaerobacterium aotearoense* (Liu et al. 1996)
 - Thermoanaerobacterium polysaccharolyticum* (Cann et al. 2001)
 - Thermoanaerobacterium saccharolyticum* (Lee et al. 1993)
 - Thermoanaerobacterium thermosaccharolyticum* (Cann et al. 2001)
 - Thermoanaerobacterium thermosulfurigenes* (Lee et al. 1993)
 - Thermoanaerobacterium xylanolyticum* (Lee et al. 1993)
 - Thermoanaerobacterium zeae* (Cann et al. 2001)
 2. Reduces thiosulfate to hydrogen sulfide (H₂S)
 - Thermoanaerobacter brockii* (Lee et al. 1993)
 - Thermoanaerobacter ethanolicus* (Lee et al. 1993)
 - Thermoanaerobacter mathranii* (Larsen et al. 1997)
 - Thermoanaerobacter thermohydrosulfuricus* (Lee et al. 1993)
 - Thermoanaerobacter tengcongensis* (Xue et al. 2001)
 - Thermoanaerobacter wiegeli* (Cook et al. 1996)

Among the ethanol-producing thermophiles, *C. thermocellum* was extensively studied for its ability to degrade cellulose and produce ethanol (Wiegel 1980, 1992). Strains of *C. thermocellum* are readily isolated from nearly all decaying organic material. They produce 0.3 to nearly 1 mole of ethanol per mole of glucose-equivalent contained in the cellulose utilized. It was possible to develop strains with an increased tolerance to ethanol (up to 8%; based on cellulose degradation) and an improved ratio of ethanol to acetate produced (from 1:1 to 10:1); however, growth of the mutants was still inhibited to 50% when 5% of ethanol was present in the growth medium (reviewed by Wiegel 1980). Isolation of strains that tolerate 4–5% ethanol was reported (Rani and Seenayya 1999). *Clostridium thermocellum* forms stable mixed cultures with saccharolytic organisms in a beneficial, syntrophic association. Cocultures of *C. thermocellum* and the saccharolytic ethanol-producing *Thermoanaerobacter ethanolicus* produced a significantly higher amount of ethanol from cellulose than the pure cultures produced (Wiegel 1980), suggesting that the cellulolytic activity of *C. thermocellum* is in practice more important than its ethanol-producing activity for the production of ethanol from cellulose. Since the early 1980s, the cellulolytic enzymes of *C. thermocellum* have been subjects

of active research, and the cellulosome, an extracellular supramolecular machine that can efficiently degrade crystalline cellulose substrates, was identified through this research (Shoham et al. 1999).

The genera *Thermoanaerobacter* and *Thermoanaerobacterium* contain saccharolytic species with a high ethanol productivity. The thermophilic anaerobes that have T_{\max} above 72 °C and can produce more than 1.5 moles of ethanol per mole of glucose consumed are *Thermoanaerobacter ethanolicus* (including the former *Clostridium thermohydrosulfuricum* strain 39E), *Thermoanaerobacter brockii* subspecies *finii* (formerly *Thermoanaerobacter finii*), and *Thermoanaerobacter thermohydrosulfuricus*. Some of these thermophiles were isolated from hot springs, where the glucose concentration is not high. Therefore, the observed high ethanol productivity of the newly isolated strains, when provided with high glucose concentrations in the laboratory, may represent a lack of refined regulatory mechanisms for these organisms to respond to rich growth conditions. After repeated subculturing in a rich medium, these organisms may adapt to a metabolism producing more acetate and less ethanol (Wiegel 1992).

Thermoanaerobacter ethanolicus has a broad pH optimum between 5.5 and 8.5 (growth occurs between pH 4.5 and 9.5), and it ferments glucose to ethanol (up to 1.8 moles ethanol per mole of glucose used) as efficiently as yeast and *Zymomonas* (Wiegel 1992). In addition, *T. ethanolicus* has a broad substrate range: glucose, xylose, oligomers of xylose, xylan, mannose, ribose, arabinose, lactose, cellobiose, maltose, starch, and pyruvate are used. These properties make *T. ethanolicus* an attractive candidate for the conversion of lignocellulosic material or whey into ethanol.

Enzymology of Ethanol Formation

Pyruvate is the central metabolic intermediate during sugar metabolism. The saccharolytic ethanol-producing bacteria can be divided into two groups based on how pyruvate is converted into the direct precursor for ethanol formation. One group, which encompasses the majority of fermentative bacteria, converts pyruvate into acetyl-CoA and CO₂, and acetyl-CoA is then reduced to acetaldehyde by aldehyde dehydrogenase. Like yeasts, the other group, including *Z. mobilis*, *Sarcina ventriculi*, *Erwinia amylovora*, and the acetic acid bacteria, converts pyruvate directly into acetaldehyde and CO₂ by pyruvate decarboxylase (Bringer-Meyer et al. 1986). Acetaldehyde is reduced to ethanol by alcohol dehydrogenase. The alcohol-producing organisms have multiple alcohol dehydrogenases (ADHs), and in many cases, the physiological importance of each ADH isozyme remains to be determined.

Pyruvate Decarboxylase

The thiamine pyrophosphate- and Mg²⁺-dependent pyruvate decarboxylase (EC 4.1.1.1) catalyzes the nonoxidative

decarboxylation of pyruvate to form acetaldehyde and CO₂. Pyruvate decarboxylase (PDC) is widely present in plants and fungi, but its occurrence among the bacteria is limited. Constituting 4–6% of the total soluble protein of *Z. mobilis*, PDC is one of the most abundant proteins in this organism (Bringer-Meyer et al. 1986). Also, PDC has been purified from *Z. mobilis* (Hoppner and Doelle 1983; Bringer-Meyer et al. 1986), and its structural gene has been cloned from two strains of *Z. mobilis* (Brau and Sahn 1986; Conway et al. 1987; Neale et al. 1987; Reynen and Sahn 1988). The *Z. mobilis* PDC is a tetrameric protein consisting of apparently identical subunits with a molecular weight of 56,500. The *pdc* gene of *Z. mobilis* ATCC 29191 encodes a polypeptide of 567 amino acids (Neale et al. 1987; Reynen and Sahn 1988), whereas the *pdc* gene of *Z. mobilis* ATCC 31821 encodes a polypeptide of 559 amino acids (Conway et al. 1987). The difference involves two internal amino acids and seven at the C-terminus. The K_M of PDC for pyruvate was first reported at 4.4 mM (Hoppner and Doelle 1983). But when the PDC activity was measured in the presence of Mg²⁺ (20 mM) and thiamine pyrophosphate (1.5 mM), a K_M of 0.4 mM was found (Bringer-Meyer et al. 1986). The lower K_M value of *Z. mobilis* PDC for pyruvate should allow the enzyme to compete favorably against the other pyruvate-utilizing enzymes (e.g., pyruvate formate lyase [$K_M=2.05$ mM] and D-lactate dehydrogenase [$K_M=4.4$ mM]) in *E. coli* (Brau and Sahn 1986). This difference in K_M values for pyruvate could explain the increase in ethanol production from 6.5 to 41.5 mM and the lack of acid production when a recombinant strain of *E. coli* harboring the *Z. mobilis pdc* gene was compared with the parent strain (Brau and Sahn 1986). The apparent benefit of expressing *Z. mobilis* PDC in *E. coli* for ethanol production is confirmed by the successful engineering of *E. coli* for fuel ethanol production (see section [Metabolic Engineering](#) in this chapter). Antiserum raised against *Z. mobilis* PDC did not detect any hybridizing protein in cell extracts of *Sarcina ventriculi*, *Erwinia amylovora*, *Gluconobacter oxydans*, or *Saccharomyces cerevisiae*, although the PDCs of *Z. mobilis* and *S. cerevisiae* have a similar molecular size and subunit structure (Bringer-Meyer et al. 1986).

In anaerobic bacteria, oxidation of pyruvate is generally catalyzed by a ferredoxin- or flavodoxin-linked pyruvate dehydrogenase (Chen 1987, 1993) to form acetyl-CoA, CO₂, and reduced ferredoxin or flavodoxin. In CO-utilizing organisms, acetyl-CoA is synthesized by the nickel-containing CO dehydrogenase/acetyl-CoA synthase (Ragsdale and Riordan 1996). Acetyl-CoA is reduced by acyl-CoA-dependent aldehyde dehydrogenases (ALDHs) to acetaldehyde.

CoA-Acylating Aldehyde Dehydrogenase

The reduction of acetyl-CoA to acetaldehyde is catalyzed by CoA-acylating aldehyde dehydrogenase (EC 1.2.1.10), which catalyzes the reaction $\text{Acyl-CoA} + \text{NAD(P)H} + \text{H}^+ \rightleftharpoons \text{aldehyde} + \text{CoASH} + \text{NAD(P)}^+$. Although more than 150 full-length aldehyde dehydrogenase (ALDH) sequences are now compiled

and aligned at the {website} (http://www.psc.edu/biomed/pages/researchCol_HBN_ALDH.html), relatively few ALDHs, especially CoA-acylating ALDHs, have been isolated and characterized from ethanol-producing organisms. Most organisms have several distinct ALDH genes, and 13 have been recognized in the *E. coli* genome (Perozich et al. 1999). Nevertheless, only the *adhE* gene has been shown to be responsible for the CoA-linked ALDH activity and is required for ethanol production in *E. coli* (Clark 1989; Holland-Staley et al. 2000). The ADH-E protein of *E. coli* has been purified as a polymer, and it has a third function, the pyruvate-formate lyase (PFL) deactivase activity, besides the acetyl-CoA reducing activity and ADH activity (Kessler et al. 1991, 1992). Based on its molecular size and its ADH and CoA-acylating ALDH activity, the ALDH purified from *E. coli* by Fromm and coworkers (Rudolph et al. 1968; Shone and Fromm 1981) appears to be the *adhE* product. Results of steady-state measurements (in the direction of CoA-acylation) suggest that the enzyme uses a bi-uni-uni-uni ping-pong mechanism in which NAD⁺ binds to the free enzyme followed by acetaldehyde; the product NADH is then released before CoASH can bind, and acetyl-CoA is the final product released (Shone and Fromm 1981).

In the butanol- and ethanol-producing clostridia, two types of CoA-acylating ALDHs have been found (Toth et al. 1999). *Clostridium acetobutylicum* has an *adhE*- or *aad*-encoded enzyme very similar to the ADH-E of *E. coli* (Fischer et al. 1993; Nair et al. 1994), whereas *Clostridium* species NRRL B643 (Palosaari and Rogers 1988) and *C. beijerinckii* (Yan and Chen 1990; Toth et al. 1999) have a dimeric enzyme with a subunit of 55–56 kDa. The gene (*ald*) encoding the *C. beijerinckii* ALDH has been cloned and sequenced (Toth et al. 1999). Results of Southern analysis suggest that each species of the butanol- and ethanol-producing clostridia uses either an aldehyde-alcohol dehydrogenase or an aldehyde dehydrogenase, but not both, for the reduction of acyl-CoA to the respective aldehyde. The ALDH of *C. beijerinckii* is most similar to the *eutE*-encoded ALDH of *Salmonella typhimurium* and *E. coli*, which use the ALDH during growth on ethanolamine.

Alcohol Dehydrogenase

Alcohol dehydrogenase (ADH; EC 1.1.1.1 for NAD⁺-linked ADH; EC 1.1.1.2 for NADP⁺-linked ADH; EC 1.1.1.71 for NAD(P)⁺-linked ADH) catalyzes the readily reversible reaction: aldehyde or ketone + NAD(P)H + H⁺ ⇌ primary or secondary alcohol + NAD(P)⁺. ADHs may be differentiated by their coenzyme and substrate specificities, metal requirement, and the number and size of their subunits (Reid and Fewson 1994).

Multiple ADHs are often present in an organism (Chen 1995). Two ADHs have been found in *Z. mobilis* (Wills et al. 1981; Kinoshita et al. 1985; Neale et al. 1986). Both ADHs use NADH to reduce acetaldehyde to ethanol and were reported to be dimeric or tetrameric. ADH-I is a zinc enzyme with a subunit molecular weight of 40,000 (Kinoshita et al. 1985;

Neale et al. 1986), whereas ADH-II is activated by iron (Scopes 1983; Neale et al. 1986) and has a subunit molecular weight of 37,000 (Neale et al. 1986) or 38,000 (Kinoshita et al. 1985). ADH-II accounts for 90 % of ADH activity in cell extracts (Neale et al. 1986). It has been proposed that ADH-I forms a complex with glyceraldehyde-3-phosphate dehydrogenase and phosphoglycerate kinase (Aldrich et al. 1992). Mutants lacking ADH-II but not ADH-I have been obtained (O'Mullan et al. 1995). These mutants were isolated by using allyl alcohol as the selecting agent. ADH-I mutants may not be detectable by this procedure because of the high activity of ADH-II, which would reduce allyl alcohol to toxic acrolein more rapidly than would ADH-I, and perhaps because of the presence of ADH-I in an enzyme complex. The level of ADH-I and ADH-II can be modulated by iron and zinc (Mackenzie et al. 1989). The structural gene for ADH-I, designated *adhA*, has been cloned and sequenced (Keshav et al. 1990), and it encodes a polypeptide of 337 amino acids with a molecular weight of 36,096. The structural gene for ADH-II, designated *adhB*, encodes a polypeptide of 383 amino acids with a molecular weight of 40,141 (Conway et al. 1987; Yoon and Pack 1990). The *adhB* gene of *Z. mobilis* has been used in the engineering of *E. coli* for ethanol production from lignocellulosic material (see section **“Metabolic Engineering”** in this chapter).

ADHs have been purified from the ethanol-producing thermophiles *Thermoanaerobacter brockii* subsp. *brockii* (Lamed and Zeikus 1981) and *Thermoanaerobacter ethanolicus* (Bryant et al. 1988; Burdette and Zeikus 1994). Although these thermophiles do not produce secondary alcohols, an NADP(H)-dependent ADH purified from these organisms is active in reducing both aldehydes and ketones to the respective primary or secondary alcohols. In addition, the secondary ADH from *T. ethanolicus* 39E can produce ethanol from acetyl-CoA, indicating the presence of acetyl-CoA reductive thioesterase (CoA-acylating ALDH) activity in the enzyme (Burdette and Zeikus 1994). The structural gene for the primary-secondary ADH has been cloned from *T. ethanolicus* 39E (Burdette et al. 1996) and *T. brockii* subsp. *brockii* (Peretz et al. 1997). X-ray crystallographic data (Korkhin et al. 1998) show that the primary-secondary ADH of *T. brockii* subsp. *brockii* is structurally related to the primary-secondary ADH of *Clostridium beijerinckii* NRRL B593, which produces isopropanol in addition to *n*-butanol and ethanol (Korkhin et al. 1998).

Fermentative growth of *E. coli* depends on the *adhE*-encoded protein, which is a polypeptide of 891 amino acids, with a molecular weight of 96,008, and has CoA-acylating ALDH activity in addition to ADH activity (Clark 1989; Goodlove et al. 1989). Thus, ADH-E is responsible for the two reductive reactions in converting acetyl-CoA to ethanol and the regeneration of NAD⁺. The *adhE* gene is expressed only under anaerobic growth conditions, and the ADH-E protein is inactive in air. Interestingly, mutations in the promoter region and in the coding region of *adhE* allowed production of active ADH-E under aerobic growth conditions, and the amino acid Glu568 alone determines the oxygen sensitivity of ADH-E (Holland-Staley et al. 2000). In addition to the aldehyde-alcohol

dehydrogenase, *E. coli* has a 1,2-propanediol oxidoreductase (encoded by the *fucO* gene), which has 41.7 % identity at the amino acid level with the iron-containing ADH-II of *Z. mobilis* (Conway and Ingram 1989).

Toxicity of Ethanol to Microbial Cells

Short-chain alcohols (C_1 – C_5) elicit a number of cellular responses that are potentially cytotoxic, and this cytotoxicity is manifested in all cell types, although the threshold level of alcohol cytotoxicity may vary from organism to organism (Baker and Kramer 1999). Effects of alcohols on microorganisms have been reviewed (Ingram and Buttke 1984; Ingram 1986; Buchholz et al. 1987; Mishra and Kaur 1991). Reviews are also available on ethanol tolerance in bacteria (Ingram 1990), *E. coli* (Ingram and Dombek 1989), *Z. mobilis* (Ingram and Dombek 1989; Rogers et al. 1989), and clostridia (Linden and Kuhn 1989). Cytotoxicity is the basis for the practical use of alcohols as a disinfectant or as a preservative, but it is also a major factor limiting the final ethanol concentration during commercial fermentation.

The cytotoxicity of short-chain alcohols ranges from reversible effects to cell death. Besides the toxicity to microbes, human exposure to ethanol and other short-chain alcohols in the environment is widespread because these alcohols are extensively used as industrial solvents and are increasingly used as a component of automobile fuels. In mammalian cells, aberrations in phospholipid and fatty acid metabolism, changes in the cellular redox state, disruptions of the energy state, and increased production of reactive oxygen metabolites have been implicated in cellular damage resulting from acute or chronic exposure to short-chain alcohols. Such cellular damage can result in disruptions of the intracellular signaling cascades and decreases in phosphorylation potential and lipid peroxidation, which are the suggested mechanisms by which alcohols can affect the rate of cell proliferation (Baker and Kramer 1999). Nonoxidative metabolism of short-chain alcohols, including synthesis of alcohol phospholipids and fatty acid alcohol esters, is an additional mechanism by which alcohols can affect membrane structure and compromise cell function. The reasons for specific cell types to exhibit different sensitivities to individual short-chain alcohols have been attributed to unique membrane compositions (Buchholz et al. 1987; Ingram 1990) and to unique metabolites produced in the affected cell and to perturbations of functions unique to the cell type (Baker and Kramer 1999).

Concentrations of ethanol above 15 % result in immediate inactivation of most vegetative organisms, with spores being considerably more resistant, whereas low concentrations of ethanol also render bacteria more sensitive to inactivation by ionizing radiation and by lipophilic acids (Ingram and Buttke 1984). The toxicity of ethanol to yeasts and bacteria has a major impact on the cost of industrial ethanol fermentation. As ethanol accumulates in the growth medium, the rate of conversion of sugars into ethanol declines progressively, and the fermentation terminates when an ample supply of substrates is still available in the medium. The limit of the achievable ethanol concentration

in a reactor and the decreasing rate of ethanol accumulation during fermentation increase the cost of the process because the production facility cannot be used more efficiently. It is thus important to understand the mechanism of ethanol toxicity so that bacterial strains more tolerant to ethanol may be developed for industrial uses. However, when studying ethanol toxicity or tolerance, it is useful to consider that rather than the increasing ethanol concentration, other growth stage-related changes in the medium composition might inhibit growth. It has been reported that salt accumulation resulting from the addition of base for pH control, not ethanol, limits the growth of an ethanol-producing organism (Lynd et al. 2001).

The cell membrane has been identified as the prime target for the toxic effect of ethanol, but other cellular components can also be deleteriously affected by ethanol to contribute to the cytotoxicity of ethanol (Ingram 1986; Ingram and Dombek 1989; Mishra and Kaur 1991). A primary action of ethanol in biological systems is to increase membrane leakage. The rates of leakage of hydrogen, magnesium, and potassium ions increased with added ethanol. Nucleotides are lost from cells at a surprising rate in the absence of ethanol, and this rate of loss is accelerated by the addition of ethanol (Ingram 1990). Loss of magnesium ions and nucleotides can cause a decrease in glycolytic flux and hence lower fermentation activity. At higher ethanol concentrations, the integrity of the membrane is further disrupted, and large molecules like proteins are also lost, and cell death will follow.

From a consideration of the possible structural and functional changes in the membrane as a result of a change in the fatty acyl composition of the membrane lipids, it is possible to infer the mechanism by which ethanol inhibits growth and survival through its actions on the plasma membrane (Ingram 1986, 1990). Ethanol exerts its effects on the membrane by affecting hydrophobic associations. Thus, the potency of alcohols as inhibitors of cellular functions is directly related to hydrophobicity, rather than involving specific steric interactions or receptors. Ethanol is less polar than water but more polar than the hydrophobic core of the membrane. High concentrations of ethanol in the culture fluid and cytoplasm alter the colligative properties of the culture fluid and cytoplasm. Ethanol increases the dielectric strength and the strength of ionic or coulombic interactions in the aqueous milieu, hence causing a decrease in the ability of the aqueous environment to accommodate charged species and a shift of the pK_a of all ionizable groups toward the conjugate neutral form. Such changes may alter the conformation of and interactions between macromolecules, the pH optima for enzymic reactions, or the pH of the environment itself (Ingram 1990).

When situated within the hydrophobic core of the membrane, ethanol decreases the dielectric strength of the membrane, the primary barrier for the cell, which in turn increases the ability of the membrane core to accommodate charged or polar molecules. The passage of molecules across the membrane is restricted primarily by the energy barrier for their transfer from an aqueous to a hydrophobic environment. Ethanol decreases this energy barrier both by its effects on the aqueous

milieu (decreasing polarity) and its effects on the hydrophobic core of the membrane (increasing polarity), thus increasing the permeability of the membrane to polar and charged molecules (Ingram 1990).

Research conducted with *E. coli* and *S. cerevisiae* shows that in response to elevated levels of ethanol in the surrounding medium, the composition of the fatty acids in the cell membrane changes with an increase in the proportion of unsaturated long-chain fatty acids, especially the *cis*-18:1 (Δ 11) fatty acid (vaccenic acid) for *E. coli* and the *cis*-18:1 (Δ) fatty acid (oleic acid) for *S. cerevisiae* (Ingram 1986). These findings suggest that the changed fatty acid compositions of the membrane lipids and hence the properties of the cell membrane may afford the cells a greater tolerance toward ethanol. The fatty acid composition of the membrane lipids of naturally ethanol-tolerant organisms provides supporting evidence for this relationship.

Zymomonas mobilis, *Lactobacillus homohiochii*, and *Lactobacillus heterohiochii* are among the most ethanol-tolerant organisms so far identified. (*Lactobacillus heterohiochii* is now considered a subjective synonym of *Lactobacillus fructivorans* because of high DNA/DNA homology between the strains; Weiss et al. 1983.) *Zymomonas mobilis* is unusual among the ethanol-producing bacteria in that it can produce ethanol to a concentration of 12% (w/v), which is comparable to that of the yeast *S. cerevisiae*. In comparison, growth of *A. woodii* can tolerate an ethanol concentration of 4.6% (w/v), which is considered high for bacteria (Buschhorn et al. 1989). The membrane of *Z. mobilis* maintains a stable and exceptionally high amount (70 % of the fatty acids) of vaccenic acid and unusual hopanoids, which are evolutionary precursors of sterols (Buchholz et al. 1987). Ethanol-dependent changes in the membranes of *Z. mobilis* include a decrease in the phospholipid content, an increase in the proportion of cardiolipin and phosphatidylcholine, and an increase in the proportion of hopanoids. *Lactobacillus homohiochii* and *L. heterohiochii* are not ethanol-producing bacteria; they were originally isolated as spoilage organisms from Japanese rice wine (Kitahara et al. 1957; Demain et al. 1961). These two lactobacilli can grow in ethanol concentrations above 16% (w/v), and both organisms exhibit ethanol-inducible changes in fatty acid composition. During growth in the presence of high concentrations of ethanol, the membranes of *L. homohiochii* contain less than 3% of saturated fatty acids, with the balance being primarily the *cis*-18:1 (Δ 11) vaccenic acid (Uchida 1975b). *Lactobacillus heterohiochii* exhibits an ethanol-inducible increase in the proportion of long-chain, *cis*-mono-unsaturated fatty acids including 18:1, 20:1, 22:1, 24:1, 26:1, 28:1, and 30:1 fatty acids (Uchida 1974, 1975a). During growth in the presence of ethanol, over 30 % of the fatty acyl chains in the membranes of *L. heterohiochii* are monounsaturated and have a chain length of 20 or more carbons, which is a property not yet observed in any other organism (Ingram 1986).

The relationship between the fatty acid composition of the membrane lipids and an organism's ethanol tolerance also has been investigated using mutants of *E. coli*. The membrane fatty acyl composition of *E. coli* is easily manipulated using mutants

defective in lipid biosynthesis and fatty acid supplements (Ingram and Buttke 1984). Mutant strains of *E. coli*, which are unable to synthesize vaccenic acid (an 18:1 fatty acid), contain membranes composed of nearly equal proportions of palmityl and palmitoleyl residues. These mutants are hypersensitive to growth inhibition and death caused by exposure to ethanol in comparison to the wild-type cells. Exogenously added fatty acids are readily incorporated into *E. coli* cells, and addition of 18:1 fatty acids to the growth medium resulted in an increase in the growth rate of the mutant in the presence of ethanol and a restoration of the tolerance level to that of the wild-type strain. No other fatty acids were found beneficial. Similar enhancement in ethanol tolerance was observed in ethanol-producing yeasts when the fermentation medium was supplemented with unsaturated fatty acids or sterols (Ingram and Buttke 1984; Mishra and Kaur 1991). These studies have led to the conclusion that an elevated level of ethanol tolerance involves an increase in the fatty acyl chain length and in the proportion of *cis*-mono-unsaturated fatty acids in the membrane lipids, and with *E. coli* at least, the increase in chain length appears to be more significant than the increase in *cis*-unsaturation. The adaptative changes in the fatty acyl composition of the membrane of the ethanol-tolerant cells indicate that the plasma membrane is a flexible system that may be manipulated by genetic engineering to increase the ethanol tolerance of the cell.

Metabolic Engineering

Efforts to use genetic tools to improve bacteria for ethanol production have focused on the enteric bacteria (Ingram et al. 1998; 1999) and *Z. mobilis* (Himmel et al. 1997). The rationale for this endeavor resides in the fact that for subtropical or temperate regions, the abundant and renewable lignocellulosic biomass is the only choice of carbon substrates for an expanded fermentation industry because the starchy grains will be increasingly needed as food and feed and hence cannot meet the growing need of the ethanol industry. The yeast *S. cerevisiae* is not chosen for several reasons: (1) it cannot efficiently use the pentose sugars that are the major component of hemicellulose, (2) it is less amenable to genetic manipulation than the prokaryotes, and (3) it has different requirements for O₂ during growth and during ethanol production, which practically limit the duration of the production period. On the other hand, enteric bacteria can ferment these pentose sugars, and *Z. mobilis* has superb ethanol tolerance and high specific rates of sugar uptake and ethanol production, both under anaerobic conditions. Therefore, efforts of metabolic engineering have been directed to either expanding the substrate range of *Z. mobilis* or increasing the ethanol productivity of enteric bacteria.

Z. mobilis

Results of earlier genetic studies with *Z. mobilis* have been reviewed (Rogers et al. 1982), and mutants with better ethanol

tolerance and better viability in liquid media were selected. The use of recombinant DNA techniques allowed the construction of a chimeric plasmid carrying a xylose assimilation operon (*xylA* and *xylB* genes under the promoter for glyceraldehyde-3-phosphate) and a pentose phosphate pathway operon (*tal* and *tktA* genes under the promoter for enolase) consisting of the *E. coli* genes or gene homolog encoding xylose isomerase (*xylA*), xylulokinase (*xylB*), transaldolase (*tal*) and transketolase (*tkt*) under the control of strong promoters from *Z. mobilis* (Zhang et al. 1995). The recombinant *Z. mobilis* harboring the plasmid expresses the respective enzymes, can grow on xylose as the sole carbon source, and produces 1.43 moles ethanol per mole of xylose consumed (86% theoretical yield). In the presence of a mixture of glucose and xylose, the recombinant strain fermented both sugars to ethanol at 95% of theoretical yield within 30 h. Glucose is used at a faster rate than xylose by the recombinant strain, although there is not an apparent diauxic effect. A recombinant strain of *Z. mobilis* capable of fermenting arabinose to ethanol has also been constructed (Himmel et al. 1997). These accomplishments provide a foundation for the further broadening of the substrate range of *Z. mobilis*.

Enteric Bacteria

The metabolic engineering of enteric bacteria for the production of ethanol from hexose and pentose sugars, the major components of hemicellulose syrup, has been reviewed (Ingram and Doran 1995; Ingram et al. 1998, 1999). Initial efforts involved the introduction of recombinant plasmids carrying either the *pdc* gene or the *pdc* and *adhB* genes of *Z. mobilis* into enteric bacteria to obtain high ethanol production from pentose and hexose sugars. When the *pdc* gene alone was introduced into wild-type *Klebsiella planticola* (Tolan and Finn 1987) or *K. planticola* mutant deficient in pyruvate formate lyase (Feldmann et al. 1989) or *E. coli* (Braun and Sahm 1986), increased ethanol production from xylose or glucose was observed. However, the recombinant strains exhibited plasmid instability, decreased ethanol tolerance, decreased growth rate under fermentative conditions, decreased cell yield, incomplete conversion of substrate, and accumulation of acidic fermentation products. When recombinant plasmids carrying both *pdc* and *adhB* genes of *Z. mobilis* were introduced into *E. coli* (Ingram et al. 1987; Ingram and Conway 1988; Neale et al. 1988) or *Klebsiella oxytoca* (Ohta et al. 1991b), the central metabolism was effectively redirected into ethanol production under both aerobic and anaerobic conditions, resulting in diminished acid production and dramatically increased final cell density. The ADH-II of *Z. mobilis* has a K_M of 12 μM for NADH, which is much lower than those of the competing dehydrogenases of *E. coli* (Ingram and Conway 1988). A high level of ADH-II activity in the recombinant *E. coli* results in efficient removal of acetaldehyde to increase ethanol production, to facilitate the continued action of pyruvate decarboxylase, and to prevent the production of acids. The results

indicate that the acids produced by enteric bacteria are more damaging than ethanol is to the cell (Ingram and Conway 1988).

For an efficient transfer of both the *pdc* and the *adhB* genes of *Z. mobilis* into different recipient cells, an artificial operon, dubbed the “PET operon” for the production of ethanol, has been constructed as a portable ethanol production cassette (Ingram et al. 1987). The PET operon consists of the *Z. mobilis* *pdc* and *adhB* genes under the control of the *lac* promoter, and it was initially introduced into recipient enteric bacteria on a pUC18 plasmid. Use of a putative *Z. mobilis* promoter in place of the *E. coli* *lac* promoter for the PET operon gave optimal expression of PDC and ADH-II activities and much higher ethanol production in recombinant *E. coli* strains harboring the plasmid (Ingram and Conway 1988).

To alleviate the problem of plasmid instability, *Z. mobilis* *pdc* and *adhB* genes were successfully inserted into the chromosome of *E. coli* at the *pfl* site under the control of the *pfl* promoter (Ohta et al. 1991a). The *pfl* site (encoding pyruvate formate lyase or PFL) was chosen because PFL represents a competing branch point (causing diversion of pyruvate to acid production) and because the *pfl* gene is expressed at very high levels during anaerobic growth. The latter is important for high-level expression of PDC and ADH-II from single-copy genes in *E. coli*. Additional genetic modifications, which include a selection for resistance to a high level of chloramphenicol, inactivation of succinate production, and block of homologous recombination, were required to increase the level of expression, to decrease acid production, and to ensure genetic stability. The resulting *E. coli* strain was designated *E. coli* KO11 (Ohta et al. 1991a). Ethanol concentrations of 54.4 and 41.6 g/l were obtained from 10% glucose and 8% xylose, respectively. Although the high yield was partly attributed to the utilization of fermentable complex nutrients in the medium, that *E. coli* can accumulate ethanol above 5 % is significant. *Escherichia coli* KO11 has since been used widely to demonstrate the fermentation of hemicellulose hydrolysates from various lignocellulosic materials (Ingram et al. 1999). *Zymomonas mobilis* *pdc* and *adhB* genes have also been integrated into the *pfl* gene on the chromosome of *K. oxytoca* to enable the recombinant strain P2 to produce ethanol from cellulose and hemicellulose (Wood and Ingram 1992). In 1991, the use of recombinant *E. coli* KO11 harboring the *Z. mobilis* *pdc* and *adhB* genes for ethanol production was awarded the United States patent no. 5,000,000 (Ingram et al. 1991).

When autoclaved crystalline cellulose is the substrate, commercial fungal (*Trichoderma*) cellulase is added to the growth medium to allow simultaneous saccharification and fermentation or SSF (Doran and Ingram 1993; see “Polyhydroxyalkanoic Acids” in Organic Acid and Solvent Production, Part I in this handbook). When sugarcane bagasse is the substrate, a pretreatment is essential to render the cellulose accessible to enzymic digestion. Either ammonia freeze explosion (AFEX) or hydrolysis of hemicellulose with dilute sulfuric acid is an effective pretreatment to increase cellulose digestibility (Doran et al. 1994). At present, low sugar concentrations in hemicellulose hydrolysate rather than alcohol tolerance of

the bacteria limit the final concentration of ethanol achieved during fermentation.

During the pretreatment of lignocellulose with acid, substances toxic to enteric bacteria are produced. At present, additional treatments of the acid hydrolysate are necessary, which include the separation of liquid (hemicellulose syrup) and solid (cellulose and lignin) followed by washing and detoxification steps. The hemicellulose syrup containing the monosaccharides of hemicellulose is fermented to ethanol by *E. coli* KO11. The fibrous solid containing cellulose and lignin is converted to ethanol by SSF using recombinant *K. oxytoca* and commercial fungal cellulase, with the lignin-rich residue after SSF burned to provide energy (Ingram et al. 1999).

Other Bacteria

The *Z. mobilis* *pdC* gene was introduced into the soft-rot bacterium *Erwinia chrysanthemi* to produce ethanol from xylose and arabinose (Tolan and Finn 1987). Plasmids carrying the PET operon have been introduced into the soft-rot bacteria *Erwinia carotovora* and *E. chrysanthemi* (Beall and Ingram 1993). These plant pathogenic bacteria have the native ability to secrete a battery of hydrolases and lyases to aid in the solubilization of lignocellulose and to macerate and penetrate plant tissues. Strains harboring the PET operon produced ethanol efficiently from glucose, cellobiose, and xylose. The PET operon has also been introduced into *Bacillus subtilis* and *Bacillus polymyxa* (de F. S. Barbosa and Ingram 1994). The *Z. mobilis* genes encoding PDC and ADH are expressed in these recombinant strains; however, the level of expression is not high enough for ethanol production. The presence of multiple proteinases in these Gram-positive bacteria may limit high-level expression. Although the glycohydrolases of Gram-positive organisms may prove advantageous for the production of ethanol from cellulosic material, further improvement in the expression level of the introduced ethanol-pathway enzymes will be needed to make the recombinant strains useful.

Commercial Applications

Commercial Production

Ethanol has traditionally been produced by chemical synthesis (mostly via catalytic hydration of ethylene) or by fermentation using yeasts. The synthetic procedures for ethanol production can be found in Lowenheim and Moran (1975) or Logsdon (1994), and the ethanolic fermentation using yeasts can be found in Reed (1982). The bacterial fermentation to be used by BC International Corp. (McCoy 1998) at its plant in Jennings, Louisiana, is based on United States patent no. 5,000,000 awarded to Dr. L. O. Ingram and coworkers (Ingram et al. 1991) for a recombinant *E. coli* that can ferment both pentose and hexose sugars to ethanol (see section 3 “Metabolic Engineering” in this chapter).

The proportion of ethanol produced by the synthetic and the fermentation processes is largely determined by the production costs, the market condition, and the government policies at the time. In 1935, 90% of the United States supply of industrial ethanol came from fermentation plants; less than 10% was of synthetic origin. By 1954, 70% was synthetic, and by 1963, synthetic ethanol accounted for 91% of the production (Lowenheim and Moran 1975). However, the trend has reversed since the early 1980s. During the past 25 years, the annual production of ethanol by the United States and Brazil, the two largest ethanol producers in the world, increased dramatically (Table 3.6), whereas the United States production of synthetic

Table 3.6

Production of ethanol in the United States and Brazil (in million gallons)

Year	United States		Brazil fermentation ^c
	Synthetic ^a	Fermentation ^b	
1975	217.2		132
1976	227.4		
1977	203.6		
1978	192.6		
1979	214.1	~10 ^d	
1980	220.6	175	
1981	200.2	215	
1982	155.5	350	
1983	163.7	375	
1984	161.1	430	
1985	98.7	610	
1986	80.4	710	3,434
1987	87.3	830	
1988	85.4	845	
1989	83.5	870	
1990	83.0	900	
1991	80.0	950	
1992	106.1	1,100	
1993	103.1	1,200	
1994	98.5	1,350	
1995	95.2	1,400	
1996		1,100	
1997		1,300	3,471
1998		1,400	3,646
1999		1,470	
2000		1,630	

^aConverted from data in million lbs, as collected by the International Trade Commission and reported annually in *Chemical & Engineering News* until 1995, which was the last year that such data were collected or published

^bFrom the Renewable Fuels Association (Washington, DC, United States)

^cConverted from data in million or billion liters as reported in Zanin et al. (2000)

^dSheehan (2000)

ethanol decreased from a peak of 360 million gal in 1969 (Anonymous 1979) to 100 million gal or less in the early 1990s (Table 3.6). The United States ethanol production is about 1.7 billion gal per year; roughly 350 million gallons (20%) are used in industry and beverage-making. The unprecedented increase in ethanol production in the United States after 1980 (<http://www.ethanolrfa.org>) and Brazil after 1975 (Zanin et al. 2000) is mainly because of the use of ethanol in the automobile fuel to reduce the consumption of gasoline. With properly modified gasoline engines, anhydrous ethanol can be blended with gasoline up to a concentration of 85% ethanol (E85) for automobile use, whereas hydrated ethanol (the azeotropic mixture with water, containing about 95% ethanol) can be used as straight motor fuel in alcohol-fueled automobiles (Jackson and Moyer 1991; Zanin et al. 2000). Dehydration of ethanol can now be accomplished by using a molecular sieve dehydrator

according to Commercial Alcohols, Inc. (<http://www.comalc.com>), which is the largest alcohol producer and distributor in Canada, or by the traditional procedure of adding benzene to form a ternary azeotrope containing 74% benzene, 18.5% ethanol, and 7.5% water, which has a boiling point of 68 °C, much lower than that (78.15 °C) of the ethanol-water azeotrope. Fuel ethanol and industrial ethanol can be manufactured by the same fermentation process, but with different finishing steps.

Essentially all of the fermentation ethanol is produced from sugars derived from corn (Table 3.7) and sugarcane juice (Zanin et al. 2000) using yeasts as the fermentation agent. However, BC International is building a production facility in Louisiana, in the United States, that will use *E. coli* KO11 (see section “Metabolic Engineering” in this chapter) to convert sugars present in bagasse and rice hull to ethanol

Table 3.7

Feedstock and production capacity (million gallons per year)^a of selected United States companies producing fuel ethanol

Company	Location	Feedstock	Capacity
Archer Daniels Midland	Decatur, Illinois	Corn	797
	Peoria, Illinois	Corn	
	Cedar Rapids, Iowa	Corn	
	Clinton, Iowa	Corn	
	Walhalla, North Dakota	Corn, barley	
Minnesota Corn Processor	Columbus, Nebraska	Corn	110
	Marshall, Minnesota	Corn	
Cargill, Inc.	Blair, Nebraska	Corn	100
	Eddyville, Iowa	Corn	
Williams Bio-Energy	Pekin, Illinois	Corn	100
New Energy Corp.	South Bend, Indiana	Corn	85
High Plains Corp.	York, Nebraska	Corn, milo	70
	Colwich, Kansas		
	Portales, New Mexico		
Chief Ethanol	Hastings, Nebraska	Corn	62
AGP	Hastings, Nebraska	Corn	52
BC International	Jennings, Louisiana	Bagasse, rice hull	20 ^b
Central Minnesota	Little Falls, Minnesota	Corn	18
Pro-Corn	Preston, Minnesota	Corn	18
Agri-Energy, LLC	Luverne, Minnesota	Corn	17
Exol, Inc.	Albert Lea, Minnesota	Corn	17
Al-Corn Clean Fuel	Claremont, Minnesota	Corn	17
Georgia-Pacific Corp.	Bellingham, Washington	Paper waste	7
J. R. Simplot	Caldwell, Idaho	Potato waste	6
	Burley, Idaho		
Golden Cheese Co. of California	Corona, California	Cheese whey	5
Kraft, Inc.	Melrose, Minnesota	Cheese whey	2.6

^aTotal capacity including those under construction, 2,184 million gallons per year

^bUnder construction (<http://www.ethanolrfa.org>; June, 2001)

From data of the Renewable Fuels Association (<http://www.ethanolrfa.org>)

(McCoy 1998; Table 3.7). The BC International facility has an annual production capacity of 20 million gal, which is comparable to or larger than the capacity of over 35 United States companies that are producing fuel ethanol from grains or waste materials (<http://www.ethanolrfa.org>). Positive results at the BC International plant can lead to expanded commercial uses of recombinant bacteria for the conversion of lignocellulosic material to ethanol.

Nonfuel Uses

Alcoholic beverages are perhaps the most important use for ethanol, other than its industrial uses and its use as a fuel. The use of pure ethanol in alcoholic beverages is likely limited because besides neutral spirits such as vodka, ethanol is but one of the many crucial ingredients of each distinctive beverage. Useful information on the processes for the manufacturing of alcoholic beverages can be found in the following references: wine (Benda 1982), beer (Helbert 1982), and distilled spirits (Brandt 1982).

Ethanol is one of the most versatile oxygen-containing organic chemicals. It has important uses as a solvent and in the manufacturing of other organic chemicals, pharmaceuticals, perfumes, toiletries, detergents, flavors, disinfectants, and other products (Logsdon 1994). The consumption of ethanol in these nonfuel products can be expected to grow, especially because ethanol is easily degraded in the environment and can be produced from renewable raw materials.

Fuel Ethanol

The dramatic increase in the production and use of ethanol as an automobile fuel started in 1975 when the Brazilian National Alcohol Program or Pro-Alcohol Program was implemented (Jackson and Moyer 1991; Zanin et al. 2000). Between 1975 and 1986, annual Brazilian ethanol production (from sugarcane juice) increased from 0.5 billion l (132 million gal) to 13 billion l (3,434 million gal). However, ethanol production decreased in the early 1980s before it stabilized after 1986 because of policy changes which reduced incentives for sugarcane production, the manufacturing of alcohol-driven automobiles, and the guaranteed price for ethanol. The production level was maintained at 14.16 billion l (3,741 million gal) for the 1996–1997 harvest and 13.8 billion l (3,646 million gal) for the 1997–1998 harvest. The performance of the Pro-Alcohol Program and the evolution of alcohol-fueled automobiles in Brazil were reviewed (Zanin et al. 2000).

Several reviews examined the merit, the technology, and the economics of producing fuel ethanol from lignocellulosic biomass, also known as “bioethanol” or “cellulosic ethanol” (Lynd et al. 1991; Ballerini et al. 1994; Wyman 1994, 1996; Himmel et al. 1997; Lugar and Woolsey 1999; Sheehan 2000). One review summarized key events of the last 20 years of this effort (Wyman 2001). It was stressed that the production and use of bioethanol

cause very low net greenhouse gas emissions, as shown by full fuel-cycle analysis. Fuel properties of ethanol, other additives of gasoline, and unleaded regular gasoline can be found in Jackson and Moyer (1991) and Wyman (1994). More information about the fuel properties of ethanol can be found in a book produced by the Solar Energy Information Data Bank and published by the United States Government Printing Office (Winston 1981).

Research and Development of Bacterial Ethanol Production

The technology is now available to produce fuel ethanol from lignocellulosic material. The challenge is to assemble the various process options into a commercial venture and to begin the task of incremental improvements (Ingram et al. 1999). The task of incremental improvements is a continuing one so that an initially successful process can remain competitive. For example, *E. coli* KO11 (Ohta et al. 1991a) is remarkable in having the capacity to ferment the constituent pentoses and hexoses of hemicellulose into ethanol with a high yield. Nevertheless, its ability to ferment simultaneously all the sugars in a mixture may be limited due to catabolite repression. The high ethanol productivity of *E. coli* KO11 may also be an unstable trait under certain conditions, and the ethanol tolerance of *E. coli* KO11 is still lower than that of yeasts used for commercial ethanol production. These are some of the shortcomings of *E. coli* KO11 that will require continued attention to improve. Mutants of *E. coli* KO11 have been obtained that are unable to ferment glucose and other sugars transported by the phosphoenolpyruvate-dependent sugar transport system, but these mutants retain the ability to ferment arabinose and xylose not transported by this system. Such mutants can use xylose efficiently in the presence of high concentrations of glucose, and a second fermentation step or a coculture may be employed to utilize the remaining glucose. Additional mutants have been obtained that retain the ability to ferment all sugars and can produce 60 g/l of ethanol from 120 g/l of xylose in 60 h (Lindsay et al. 1995). Using an enrichment method that selects alternatively for ethanol tolerance and for ethanol production, more ethanol-tolerant mutants of *E. coli* KO11 were isolated (Yomano et al. 1998). Conditions have been identified that cause *E. coli* KO11 to lose its high ethanol productivity. For example, maintenance of *E. coli* KO11 on xylose in chemostat cultures leads to the irreversible loss of high ethanol productivity (Dumsday et al. 1999). Such knowledge is important to the further improvement of this organism.

Research on growth and ethanol production by *Z. mobilis* is also in progress at the United States National Renewable Energy Laboratory or NREL (Himmel et al. 1997) and elsewhere (Zakpaa et al. 1997; Joachimsthal et al. 1998; McLellan et al. 1999; Silveira et al. 2001). The topics of these studies range from the selection of a mutant capable of ethanol production from glucose in the presence of 20 g/l of sodium acetate (Joachimsthal et al. 1998) to the mechanism that causes an oscillatory behavior in the continuous fermentation of *Z. mobilis*

(McLellan et al. 1999). The development of acetate-tolerant ethanol-producers is important because during acid hydrolysis of hemicellulose, acetic acid (which inhibits fermentation) is produced at a high ratio relative to fermentable sugars.

The conversion of cellulose into fermentable glucose requires the use of expensive fungal cellulase, and it remains a limiting factor in the conversion of lignocellulosic material to ethanol. There is intense research on cellulase, with an aim of decreasing the cost of cellulase production (Himmel et al. 1997). There has also been success in adding the ability to produce and secrete high levels of endoglucanase to *K. oxytoca* P2 so that the requirement for fungal cellulase is reduced in the simultaneous saccharification and fermentation (SSF) process for cellulose (Ingram et al. 1999). An alternative approach is to convert lignocellulosic material into CO and H₂ (synthesis gas), which can be converted to ethanol by some anaerobic bacteria (Clausen and Gaddy 1996). At present, the synthesis-gas fermentation has a low volumetric productivity owing to physical and biological limitations (Worden et al. 1997). Improvements in both bioreactor design and metabolic capacity of the organism will be needed to make the process commercially useful.

The thermophilic anaerobic bacteria in the genera *Thermoanaerobacter* and *Thermoanaerobacterium* may emerge as useful organisms for ethanol production from lignocellulosic material because of their high ethanol productivity and their natural ability to use a wide range of sugars, oligosaccharides, and polysaccharide. New ethanol-producing species of *Thermoanaerobacter* and *Thermoanaerobacterium* are reported (Cook et al. 1996; Liu et al. 1996; Larsen et al. 1997; Cann et al. 2001; Xue et al. 2001). These organisms offer a growing pool of potentially useful traits for use in metabolic engineering. Besides metabolic engineering, the performance of these organisms may also be enhanced under special growth conditions. A coculture of *T. ethanolicus* and *C. thermocellum* can convert cellulose into ethanol more efficiently than pure cultures into can, without the addition of fungal cellulase (Wiegel 1980). To make the thermophilic bacteria useful for commercial ethanol production, genetic tools are needed to refine their properties both now and in future incremental improvement. Electrotransformation procedures (Klapatch et al. 1996; Mai et al. 1997) as well as shuttle vectors and homologous recombination for chromosomal integration (Mai and Wiegel 2000) have been developed for *Thermoanaerobacterium saccharolyticum* or *Thermoanaerobacterium thermosaccharolyticum*. Genes for hydrolytic enzymes have been introduced into *T. saccharolyticum* and expressed (Mai and Wiegel 2000). These genetic tools should facilitate research with thermophiles such as *T. ethanolicus* and *C. thermocellum*.

Patents and Regulatory Issues

There are patents that cover three critical areas of bacterial ethanol production: the use of genetically engineered bacteria for ethanol production, the commercial production of cellulase for the saccharification of cellulosic materials, and the

development of the simultaneous saccharification and fermentation (SSF) process.

The issuance of the United States patent no. 5,000,000 (ethanol production by *Escherichia coli* strains coexpressing *Zymomonas mobilis pdc* and *adh* genes; Ingram et al. 1991) is a landmark event attesting to the innovative nature of using rationally constructed bacteria (see section [“Metabolic Engineering”](#) in this chapter) for producing ethanol from lignocellulosic material. Further improvement and extension of this approach have led to additional patents, for example, United States patents 5,028,539 (ethanol production using engineered mutant *Escherichia coli*; Ingram and Clark 1992), 5,424,202 (Ethanol production by recombinant hosts; Ingram et al. 1995b), 5,482,846 (Ethanol production by Gram-positive microbes; Ingram and Barbosa-Alleyne 1996), and 5,821,093 (Recombinant cells that highly express chromosomally integrated heterologous genes; Ingram and Ohta 1998).

The development of manufacturing processes for stable cellulytic enzymes has resulted in United States patents 3,990,945 (enzymatic hydrolysis of cellulose; Huff and Yata 1976), 5,275,944 (Thermostable purified endoglucanase from *Acidothermus cellulolyticus*; Himmel et al. 1994), and 5,712,142 (Method for increasing thermostability in cellulase enzymes; Thomas et al. 1997).

The introduction of simultaneous saccharification and fermentation (SSF) has been considered the most important process improvement made for the enzymatic hydrolysis of biomass for bioethanol production (Sheehan 2000). United States patent 3,990,944 (manufacturing alcohol from cellulosic materials using plural ferments; Gauss et al. 1976) describes the SSF process. In the SSF process, the hydrolysis of cellulosic materials to glucose by a separately prepared cellulase and the fermentation of glucose by an alcohol-producing organism occur simultaneously in a reactor under anaerobic conditions. The advantages of the SSF process include the reduction of the number of reactors required and the alleviation of product inhibition of the hydrolytic enzymes.

The construction of the 20-million gal/year plant by BC International Corporation (see section [“Commercial Production”](#) in this chapter) to utilize these technologies is an endorsement to the commercial value of the bacterial process. Future growth of the fermentation industry for producing fuel ethanol will depend on the price and availability of crude oil, the environmental issues, public policy and legislative trends, and public opinion (Himmel et al. 1997). At present, the costs of producing fuel ethanol by fermentation are still high that without tax credits and other forms of subsidy (Sheehan 2000), fermentation ethanol will not be able to compete against gasoline, especially during periods when the price of oil drops. As illustrated by what occurred in Brazil in the 1980s, the production of fermentation ethanol is vulnerable to changes in economic and political factors. The “Brazilian miracle” ended when oil prices dropped and stabilized, the government-guaranteed price for ethanol was lowered, the special credit line for the cultivation of sugarcane was cut, and the tax incentive for manufacturing alcohol-driven automobiles was reduced (Zanin et al. 2000). The continuous

growth of the demand for hydrated ethanol, which cannot be used in gasoline, further constrained the production of anhydrous ethanol. Thus, the production of fermentation ethanol in Brazil leveled off after 1986. On the other hand, the production of fuel ethanol in the United States is still on the rise (► [Table 3.7](#)), and there are laws and regulations in the United States that encourage an increase in use of ethanol in automobile fuels.

The 1990 amendments to the Clean Air Act, requiring the addition of oxygenates to gasoline to reduce the formation of carbon dioxide and ozone in urban areas where the climate conditions favor the production of these pollutants, have created demand for ethanol, which is an oxygenate. The use of methyl *tert*-butyl ether (MTBE) as an octane-rating enhancer in gasoline is being phased out because of its leakage into the groundwater, hence creating another need for ethanol, which has a high octane rating (see section ► [“Physicochemical Properties”](#) in this chapter). The Biomass R&D Act of 2000 helps to support biomass conversion projects, which can help lower the production costs for ethanol as less expensive enzymes may be developed for converting lignocellulosic material into fermentable substrates. Any legislation that would require all United States gasoline to contain a certain amount of renewable fuels will further expand the market for ethanol.

Prospects

Production of ethanol by microbial fermentation is an ancient art. The tool of molecular biology has made it possible to alter the metabolic pathways of enteric bacteria and to allow their use in commercial production of ethanol from lignocellulosic material. As illustrated by Ingram and Conway (1988), the relative activity levels of pyruvate decarboxylase and alcohol dehydrogenase in genetically engineered *E. coli* have a major influence on ethanol productivity. In *E. coli* KO11 (Ohta et al. 1991a) and *K. oxytoca* P2 (Wood and Ingram 1992), expression of these two enzymes is under the control of one promoter, the *pfl* promoter. It is conceivable that further improvement in ethanol productivity by these bacteria may be realized when the expression of these two enzymes is further fine-tuned and the competing reactions or limitations further decreased. The thermophilic ethanol producer *T. ethanolicus* (Wiegel 1992) is an attractive candidate for future commercial use because of its high ethanol productivity and its natural ability to use a wide range of substrates including pentose and hexose sugars, lactose, and oligosaccharides containing xylose. To use lignocellulosic material as the raw material for ethanol production, the polymer must be pretreated to convert it into fermentable substrates—a costly process. Future improvement in this area holds the greatest promise in making bacterial ethanolic fermentation a more successful commercial process.

Ethanol tolerance remains a potential limiting factor for ethanol production by bacteria. However, it has been shown that by suppressing acid production, the recombinant *E. coli* can produce ethanol to a much higher level than what is achievable by the

acid-producing parent strain, suggesting that carboxylic acids are more detrimental than ethanol to the cell. Therefore, when ethanol is the predominant end product, it not only facilitates product recovery but also circumvents inhibition caused by other products. At present, the low sugar concentration in the hemicellulose hydrolysate, rather than ethanol toxicity, is limiting the final ethanol concentration obtained with hemicellulosic substrates. Use of bacterial strains that are more tolerant to ethanol will improve the productivity of a process when ethanol toxicity becomes the limiting factor for the process.

The use of ethanol in automobile fuels is by far the largest use for this chemical. Inclusion of ethanol in diesel fuels will further increase its market size. The future growth of the fuel ethanol market, however, will not be determined solely by the fuel properties of ethanol, the technological capabilities for its production, and economic factors. Public policies and the attitude of the consumer will play an important role in determining whether ethanol will remain the most substantial commercial product of microbial action.

References

- Abbad-Andaloussi S, Durr C, Raval G, Petitdemange H (1996) Carbon and electron flow in *Clostridium butyricum* grown in chemostat culture on glycerol and glucose. *Microbiol* 142:1149–1158
- Abrini J, Naveau H, Nyns E-J (1994) *Clostridium autoethanogenum*, sp. nov., an anaerobic bacterium that produces ethanol from carbon monoxide. *Arch Microbiol* 16:345–351
- Alam S, Stevens D, Bajpai R (1988) Production of butyric acid by batch fermentation of cheese whey with *Clostridium beijerinckii*. *J Ind Microbiol* 2:359–364
- Aldrich HC, McDowell L, Barbosa MF, Yomano LP, Scopes RK, Ingram LO (1992) Immunocytochemical localization of glycolytic and fermentative enzymes in *Zymomonas mobilis*. *J Bacteriol* 174:4504–4508
- Anonymous (1979) Facts and figures for the U.S. chemical industry—production of organic chemicals. *Chem Eng News* 11:37
- Anonymous (2001a) Chemical prices. *Chem Mark Rep* 160(17):23–26
- Anonymous (2001b) Glycerol, propionic acid, butyric acid. *Chem Mark Rep* 259(13):30–33
- Bahl H, Müller H, Behrens S, Joseph H, Naberhaus F (1995) Expression of heat shock genes in *Clostridium acetobutylicum*. *FEMS Microbiol Rev* 17:341–348
- Baker RC, Kramer RE (1999) Cytotoxicity of short-chain alcohols. *Annu Rev Pharmacol Toxicol* 39:127–150
- Ballerini D, Desmarquest JP, Pourquie J, Nativel F, Rebeller M (1994) Ethanol production from lignocellulosics: Large scale experimentation and economics. *Bioresource Technol* 50:17–23
- Barbirato F, Chedaille D, Bories A (1997a) Propionic acid fermentation from glycerol: comparison with conventional substrates. *Appl Microbiol Biotechnol* 47:441–446
- Barbirato F, Astruc S, Soucaille P, Camarasa C, Salmon JM, Bories A (1997b) Anaerobic pathways of glycerol dissimilation by *Enterobacter agglomerans* CNCM 1210: limitations and regulations. *Microbiology* 143:2423–2432
- Barbirato F, Larguier A, Conte T, Astruc S, Bories A (1997c) Sensitivity to pH, product inhibition, and inhibition by NAD⁺ of 1,3-propanediol dehydrogenase purified from *Enterobacter agglomerans* CNCM 1210. *Arch Microbiol* 168:160–163
- Barbosa MF, Ingram LO (1994) Expression of the *Zymomonas mobilis* alcohol dehydrogenase II (*adhB*) and pyruvate decarboxylase (*pdC*) genes in *Bacillus*. *Curr Microbiol* 28:279–282
- Barik S, Prieto S, Harrison SB, Clausen EC, Gaddy JL (1988) Biological production of alcohols from coal through indirect liquefaction: scientific note. *Appl Biochem Biotechnol* 18:363–378

- Barker HA (1972) Co-enzyme B₁₂-dependent mutases causing carbon chain rearrangements. In: Boyer PD (ed) *The enzymes*, vol 6. Academic, New York, pp 509–537
- Beall DS, Ingram LO (1993) Genetic engineering of soft-rot bacteria for ethanol production from lignocellulose. *J Ind Microbiol* 11:151–155
- Benda I (1982) Wine and brandy. In: Reed G (ed) *Prescott & Dunn's industrial microbiology*, 4th edn. AVI Publishing, Westport, pp 293–402
- Billig E, Bryant DR (1991) *Oxoprocess encyclopedia of chemical technology*, vol 17, 4th edn. Wiley, New York, pp 903–919
- Boyaval P, Seta J, Gavach C (1993) Concentrated propionic acid production by electro-dialysis. *Enzyme Microb Technol* 15:683–686
- Boyaval P, Corre C, Madec MN (1994) Propionic acid production in a membrane bioreactor. *Enzyme Microb Technol* 16:883–886
- Boyaval P, Corre C (1995) Production of propionic acid. *Lait* 75:453–461
- Brandt DA (1982) Distilled beverage alcohol. In: Reed G (ed) *Prescott & Dunn's industrial microbiology*, 4th edn. AVI Publishing, Westport, pp 468–491
- Brau B, Sahm H (1986) Cloning and expression of the structural gene for pyruvate decarboxylase of *Zymomonas mobilis* in *Escherichia coli*. *Arch Microbiol* 144:296–301
- Bringer-Meyer S, Schmitz K-L, Sahm H (1986) Pyruvate decarboxylase from *Zymomonas mobilis*: isolation and partial characterization. *Arch Microbiol* 146:105–110
- Brown DP, Ganova-Raevn L, Green BD, Wilkinson SR, Young M, Youngman P (1994) Characterization of spoOA homologues in diverse Bacillus and Clostridium species identifies a probable DNA-binding domain. *Molec Microbiol* 14:411–426
- Bryant FO, Wiegell J, Ljungdahl LG (1988) Purification and properties of primary and secondary alcohol dehydrogenases from *Thermoanaerobacter ethanolicus*. *Appl Environ Microbiol* 54:460–465
- Buchholz SE, Dooley MM, Eveleigh DE (1987) *Zymomonas*—an alcoholic enigma. *Trends Biotechnol* 5:199–204
- Burdette D, Zeikus JG (1994) Purification of acetaldehyde dehydrogenase and alcohol dehydrogenases from *Thermoanaerobacter ethanolicus* 39E and characterization of the secondary-alcohol dehydrogenase (2°dh) as a bifunctional alcohol dehydrogenase-acetyl-CoA reductive thioesterase. *Biochem J* 302:163–170
- Burdette DS, Vieille C, Zeikus JG (1996) Cloning and expression of the gene encoding the *Thermoanaerobacter ethanolicus* 39E secondary-alcohol dehydrogenase and biochemical characterization of the enzyme. *Biochem J* 316:115–122
- Buschhorn H, Dü P, Gottschalk G (1989) Production and utilization of ethanol by homoacetogen *Acetobacterium woodii*. *Appl Environ Microbiol* 55:1835–1840
- Cann IKO, Stroot PG, Mackie KR, White BA, Mackie RI (2001) Characterization of two novel saccharolytic, anaerobic thermophiles, *Thermoanaerobacterium polysaccharolyticum* sp. nov. and *Thermoanaerobacterium zeae* sp. nov., and emendation of the genus *Thermoanaerobacterium*. *Int J Syst Evol Microbiol* 51:293–302
- Cayol J-L, Ollivier B, Patel BKC, Ravot G, Magot M, Ageron E, Grimont PAD, Garcia J-L (1995) Description of *Thermoanaerobacter brockii* subsp. lactiethylicus subsp. nov., isolated from a deep subsurface french oil well, a proposal to reclassify *Thermoanaerobacter finnii* as *Thermoanaerobacter brockii* subsp. finnii comb. nov., and an emended description of *Thermoanaerobacter brockii*. *Int J Syst Bacteriol* 45:783–789
- Chen J-S (1987) Electron transport in anaerobes. In: Montville TJ (ed) *Concepts in physiology and metabolism*, vol 1. CRC Press, Boca Raton, pp 61–101
- Chen J-S (1993) Properties of acid- and solvent-forming enzymes of clostridia. In: Woods DR (ed) *The clostridia and biotechnology*. Butterworth-Heinemann, Stoneham, pp 51–76
- Chen JS (1995) Alcohol dehydrogenase: multiplicity and relatedness in the solvent-producing clostridia. *FEMS Microbiol Rev* 17:263–273
- Clark DP (1989) The fermentation pathways of *Escherichia coli*. *FEMS Microbiol Rev* 63:223–234
- Clausen EC, Gaddy JL (1996) Ethanol from biomass by gasification/fermentation. In: Khan MR (ed) *Conversion and utilization of waste materials*. Taylor & Francis, Washington DC, pp 157–167
- Collins MD, Lawson PA, Willems A, Cordoba JJ, Fernandez-Garayzabal J, Garcia P, Cai J, Hippe H, Farrow JAE (1994) The phylogeny of the genus *Clostridium*: proposal of five new genera and eleven new species combinations. *Int J Syst Bacteriol* 44:812–826
- Colomban A, Roger L, Boyaval P (1993) Production of propionic acid from whey permeate by sequential fermentation, ultrafiltration, and cell recycling. *Biotechnol Bioeng* 42:1091–1098
- Conway T, Osman YA, Konnan JL, Hoffmann EM, Ingram LO (1987) Promoter and nucleotide sequences of the *Zymomonas mobilis* pyruvate decarboxylase. *J Bacteriol* 169:949–954
- Conway T, Ingram LO (1989) Similarity of *Escherichia coli* propanediol oxidoreductase (fucO product) and an unusual alcohol dehydrogenase from *Zymomonas mobilis* and *Saccharomyces cerevisiae*. *J Bacteriol* 171:3754–3759
- Cook GM, Rainey FA, Patel BKC, Morgan HW (1996) Characterization of a new obligately anaerobic thermophile, *Thermanaerobacter wiegellii* sp. nov. *Int J Syst Bacteriol* 46:123–127
- Cummins CS, Johnson JL (1986) The genus *Propionibacterium*. In: Sneath PHA, Mair NS, Sharpe ME, Holt JG (eds) *Bergey's manual of systematic bacteriology*, vol 2. Williams and Wilkins, Baltimore, pp 1346–1353
- Demain AL, Rickes EL, Hendlin D, Barnes EC (1961) Nutritional studies on *Lactobacillus heterohiochi*. *J Bacteriol* 81:147–153
- Depasse E (1945) Vue d'ensemble d'une production industrielle de cétones. *Bull Assoc Chim Sucre Distill Fr* 62:317–339
- Doran JB, Ingram LO (1993) Fermentation of crystalline cellulose to ethanol by *Klebsiella oxytoca* containing chromosomally integrated *Zymomonas mobilis* genes. *Biotechnol Progr* 9:533–538
- Doran JB, Aldrich HC, Ingram LO (1994) Saccharification and fermentation of sugar cane bagasse by *Klebsiella oxytoca* P2 containing chromosomally integrated genes encoding the *Zymomonas mobilis* ethanol pathway. *Biotechnol Bioeng* 44:240–247
- Dumdsday GJ, Zhou B, Yaqin W, Stanley GA, Pamment NB (1999) Comparative stability of ethanol production by *Escherichia coli* KO11 in batch and chemostat culture. *J Ind Microbiol Biotechnol* 23:701–708
- Dürre P, Fischer RJ, Kuhn A, Lorenz K, Schreiber W, Stürzenhofecker B, Ullmann S, Winzer K, Sauer U (1995) Solventogenic enzymes of *Clostridium acetobutylicum*, catalytic properties, genetic organization and transcriptional regulation. *FEMS Microbiol Rev* 17:251–262
- Evans PJ, Wang HY (1990) Effects of extractive fermentation on butyric acid production by *Clostridium acetobutylicum*. *Appl Microbiol Biotechnol* 32:393–397
- Fayolle F, Marchal R, Ballerini D (1990) Effect of controlled substrate feeding on butyric acid production by *Clostridium tyrobutyricum*. *J Indust Microbiol* 6:179–183
- Feldmann S, Sprenger GA, Sahm H (1989) Ethanol production from xylose with a pyruvate-formate-lyase mutant of *Klebsiella planticola* carrying a pyruvate-decarboxylase gene from *Zymomonas mobilis*. *Appl Microbiol Biotechnol* 31:152–157
- Fischer RJ, Helms J, Dü P (1993) Cloning, sequencing and molecular analysis of the sol operon of *Clostridium acetobutylicum*, a chromosomal locus involved in solventogenesis. *J Bacteriol* 175:6959–6969
- Fitz A (1878) Über spaltpilzgärungen, IV Bericht der Deutsch. Chem Ges 11:1890
- Gauss WF, Suzuki S, Takagi M (1976) US Patent 3,990,944
- Girbal L, Croux C, Vasconcelos I, Soucaille P (1995a) Regulation of metabolic shifts in *Clostridium acetobutylicum* ATCC 824. *FEMS Microbiol Rev* 17:287–297
- Girbal L, Vasconcelos I, Saint-Amans S, Soucaille P (1995b) How neutral red modified carbon and electron flow in *Clostridium acetobutylicum* grown in chemostat culture at neutral pH. *FEMS Microbiol Rev* 16:151–162
- Goodlove PE, Cunningham PR, Parker J, Clark DP (1989) Cloning and sequence analysis of the fermentative alcohol-dehydrogenase-encoding gene of *Escherichia coli*. *Gene* 85:209–214
- Gottschalk G (1986) *Bacterial metabolism*, 2nd edn. Springer, New York, pp 97–98
- Grethlein AJ, Worden RM, Jain MK, Datta R (1990) Continuous production of mixed alcohols and acids from carbon monoxide. *Appl Biochem Biotechnol* 24–25:875–884
- Gu Z, Glatz BA, Glatz CE (1998) Propionic acid production by extractive fermentation. I: solvent consideration. *Biotechnol Bioeng* 57:454–461
- Gu Z, Rickert DA, Glatz BA, Glatz CE (1999) Feasibility of propionic acid production by extractive fermentation. *Lait* 79:137–148

- Helbert JR (1982) Beer. In: Reed G (ed) Prescott & Dunn's industrial microbiology, 4th edn. AVI Publishing, Westport, pp 403–467
- Himmel ME, Adney WS, Grohmann K, Tucker MP (1994) US Patent 5,275,944
- Himmel ME, Adney WS, Baker JO, Elander R, McMillan JD, Nieves RA, Sheehan JJ, Thomas SR, Vinzant TB, Zhang M (1997) Advanced bioethanol production technologies: a perspective. In: Saha BC, Woodward J (eds) Fuels and chemicals from biomass. American Chemical Society, Washington, DC, pp 2–45, ACS Symposium Series 666
- Himmi EH, Bories A, Boussaid A, Hassani L (2000) Propionic acid fermentation of glycerol and glucose by *Propionibacterium acidipropionici* and *Propionibacterium freudenreichii* ssp. *shermanii*. Appl Microbiol Biotechnol 53:435–440
- Hippe H, Andresen JR, Gottschalk G (1991) The genus Clostridium, non-medical. In: Balows HG, Truper M, Dworkin WH, Schleifer KH (eds) The prokaryotes. Springer, New York, pp 1799–1866
- Holland-Staley CA, Lee K, Clark DP, Cunningham PR (2000) Aerobic activity of *Escherichia coli* alcohol dehydrogenase is determined by a single amino acid. J Bacteriol 18(2):6049–6054
- Hoppner TC, Doelle HW (1983) Purification and kinetic characteristics of pyruvate decarboxylase and ethanol dehydrogenase from *Zymomonas mobilis* in relation to ethanol production. Eur J Appl Microbiol Biotechnol 17:152–157
- Houge C (2000) Getting the MTBE out. Chem Eng News, p. 6
- Hsu ST, Yang ST (1991) Propionic acid fermentation of lactose by *Propionibacterium acidipropionici*—effects of pH. Biotechnol Bioeng 38:571–578
- Huff GF, Yata N (1976) US Patent 3,990,945
- Ingram LO, Buttke TM (1984) Effects of alcohols on micro-organisms. Adv Microb Physiol 25:253–300
- Ingram LO (1986) Microbial tolerance to alcohols: role of the cell membrane. Trends Biotechnol 4:40–44
- Ingram LO, Conway T, Clark DP, Sewell GW, Preston JF (1987) Genetic engineering of ethanol production in *Escherichia coli*. Appl Environ Microbiol 53:2420–2425
- Ingram LO, Conway T (1988) Expression of different levels of ethanologenic enzymes from *Zymomonas mobilis* in recombinant strains of *Escherichia coli*. Appl Environ Microbiol 54:397–404
- Ingram LO, Dombek KM (1989) Effects of ethanol on *Escherichia coli*. In: van Uden N (ed) Alcohol toxicity in yeasts and bacteria. CRC Press, Boca Raton, pp 227–237
- Ingram LO (1990) Ethanol tolerance in bacteria. Crit Rev Biotechnol 9:305–319
- Ingram LO, Alterthum F, Conway T (1991) US Patent 5,000,000
- Ingram LO, Clark DC (1992) US Patent 5,028,539
- Ingram LO, Doran JB (1995) Conversion of cellulosic materials to ethanol. FEMS Microbiol Rev 16:235–241
- Ingram LO, Beall DS, Burchhardt GFH, Guimaraes WV, Ohta K, Wood BE, Shanmugam KT, Fowler DE, Ben-Bassat A (1995) US Patent 5,424,202
- Ingram LO, Barbosa-Alleyne MDF (1996) US Patent 5,482,846
- Ingram LO, Ohta KW, B. E. (1998) US Patent 5,821,093
- Ingram LO, Gomez PF, Lai X, Moniruzzaman M, Wood BE, Yamano LP, York SW (1998) Metabolic engineering of bacteria for ethanol production. Biotechnol Bioeng 58:204–214
- Ingram LO, Aldrich HC, Borges ACC, Causey TB, Martinez A, Morales F, Saleh A, Underwood SA, Yomano LP, York SW, Zaldivar J, Zhou S (1999) Enteric bacterial catalysts for fuel ethanol production. Biotechnol Progr 15:855–866
- Jackson MD, Moyer CB (1991) Alcohol fuels. In: Kroschwitz JJ, Howe-Grant M (eds) Kirk-Othmer encyclopedia of chemical technology, vol 1, 4th edn. Wiley, New York, pp 826–864
- Jan G, Rouault A, Maubois JL (2000) Acid stress susceptibility and acid adaptation of *Propionibacterium freudenreichii* subsp. *shermanii*. Lait 80:325–336
- Jan G, Leverrier P, Pichereau V, Boyaval P (2001) Changes in protein synthesis and morphology during acid adaptation of *Propionibacterium freudenreichii*. Appl Environ Microbiol 67:2029–2036
- Jin ZW, Yang ST (1998) Extractive fermentation for enhanced propionic acid production from lactose by *Propionibacterium acidipropionici*. Biotechnol Prog 14:457–465
- Joachimsthal E, Haggett KD, Jang J-H, Rogers PL (1998) A mutant of *Zymomonas mobilis* ZM4 capable of ethanol production from glucose in the presence of high acetate concentrations. Biotechnol Lett 20:137–142
- Jones DT (1993) Mutagenesis and its application to biotechnology. In: Woods DR (ed) The clostridia and biotechnology. Butterworth-Heinemann, London, pp 77–98
- Keshav KF, Yomano LP, An H, Ingram LO (1990) Cloning of the *Zymomonas mobilis* structural gene encoding alcohol dehydrogenase I (adhA): Sequence comparison and expression in *Escherichia coli*. J Bacteriol 172:2491–2497
- Kessler D, Leibrecht I, Knappe J (1991) Pyruvate-formate-lyase-deactivase and acetyl-Co reductase activities of *Escherichia coli* reside on a polymeric protein particle encoded by adhE. FEBS Lett 281:59–63
- Kessler D, Herth W, Knappe J (1992) Ultrastructure and pyruvate formate-lyase radical quenching property of the multienzymic AdhE protein of *Escherichia coli*. J Biol Chem 267:18073–18079
- Kiatpapan P, Hashimoto Y, Nakamura H, Piao Y-Z, Ono H, Yamashita M, Murooka Y (2000) Characterization of pRG01, a plasmid from *Propionibacterium acidipropionici*, and its use for development of a host-vector system in propionibacteria. Appl Environ Microbiol 66:4688–4695
- Kinoshita S, Kakizono T, Kadota K, Das K, Taguchi H (1985) Purification of two alcohol dehydrogenases from *Zymomonas mobilis* and their properties. Appl Microbiol Biotechnol 22:249–254
- Kitahara K, Kaneko T, Goto O (1957) Taxonomic studies on the hiochi-bacteria specific saprophytes of sake. I: isolation and grouping of bacterial strains. J Gen Appl Microbiol (Japan) 3:102–110
- Klapatch RR, Guerinot ML, Lynd LR (1996) Electrotransformation of *Clostridium thermosaccharolyticum*. J Ind Microbiol 16:342–347
- Klasson KT, Ackerson MD, Clausen EC, Gaddy JL (1992) Bioconversion of synthesis gas into liquid or gaseous fuels. Enzyme Microb Technol 14:602–608
- Korkhin Y, Kalb(Gilboa) AJ, Peretz M, Bogin O, Burstein Y, Frolow F (1998) NADP-dependent bacterial alcohol dehydrogenases: crystal structure, cofactor-binding and cofactor specificity of the ADHs of *Clostridium beijerinckii* and *Thermoanaerobacter brockii*. J Mol Biol 278:967–981
- Kosaric N (1996) Ethanol-potential source of energy and chemical products. In: Rehm H-J, Reed G (eds) Biotechnology. VCH, New York, pp 123–203
- Kusano K, Yamada H, Niwa M, Yamasoto K (1997) *Propionibacterium cyclohexanicum* sp. nov., a new acid-tolerant omega-cyclohexyl/fatty acid-containing propionibacterium isolated from spoiled orange juice. Int J Syst Bacteriol 47:825–831
- Lamed RJ, Zeikus JG (1981) Novel NADP-linked alcohol-aldehyde/ketone oxidoreductase in thermophilic ethanologenic bacteria. Biochem J 195:183–190
- Larsen L, Nielsen P, Ahring BK (1997) *Thermoanaerobacter mathranii* sp. nov., an ethanol-producing, extremely thermophilic anaerobic bacterium from a hot spring in Iceland. Arch Microbiol 168:114–119
- Lee Y-E, Jain MK, Lee C, Lowe SE, Zeikus JG (1993) Taxonomic distinction of saccharolytic thermophilic anaerobes: description of *Thermoanaerobacterium xylanolyticum* gen. nov., sp. nov., and *Thermoanaerobacterium saccharolyticum* gen. nov., sp. nov.; reclassification of *Thermoanaerobium brockii*, *Clostridium thermosulfurogenes*, and *Clostridium thermohydrosulfuricum* E100-69 as *Thermoanaerobacter brockii* comb. nov., and *Thermoanaerobacter thermosulfurigenes* comb. nov., and *Thermoanaerobacter thermohydrosulfuricum* comb. nov., respectively; and transfer of *Clostridium thermohydrosulfuricum* 39E to *Thermoanaerobacter ethanolicus*. Int J Syst Bacteriol 43:41–51
- Lefranc L et Cie (1923) A process for the manufacture of butyric acid and other fatty acids with recovery of the gases of fermentation. British Patent 186–572. Chem Abstr 17:324
- Lewis VP, Yang ST (1992) Continuous propionic acid fermentation by immobilized *Propionibacterium acidipropionici* in a novel packed bed bioreactor. Biotechnol Bioeng 40:465–474
- Linden JC, Kuhn RH (1989) Biochemistry of alcohol effects on clostridia. In: van Uden N (ed) Alcohol toxicity in yeasts and bacteria. CRC Press, Boca Raton, pp 271–291
- Lindsay SE, Bothast RJ, Ingram LO (1995) Improved strains of recombinant *Escherichia coli* for ethanol production from sugar mixture. Appl Microbiol Biotechnol 43:70–75

- Liu S-Y, Rainey FA, Morgan HW, Mayer F, Wiegel J (1996) *Thermoanaerobacterium aotearoense* sp. nov., a slightly acidophilic, anaerobic thermophile isolated from various hot springs in New Zealand, and emendation of the genus *Thermoanaerobacterium*. *Int J Syst Bacteriol* 46:388–396
- Logsdon JE (1994) Ethanol. In: Kroschwitz JI, Howe-Grant M (eds) *Kirk-Othmer encyclopedia of chemical technology*, vol 9, 4th edn. Wiley, New York, pp 812–860
- Lowe SE, Jain MK, Zeikus JG (1993) Biology, ecology, and biotechnological applications of anaerobic bacteria adapted to environmental stresses in temperature, pH, salinity, or substrates. *Microbiol Rev* 57:451–509
- Lowenheim FA, Moran MK (1975) *Industrial chemicals*, 4th edn. Wiley, New York
- Lugar RG, Woolsey RJ (1999) The new petroleum. *Foreign Aff* 78:88–102
- Lynd LR (1989) Ethanol production from lignocellulosic substrates using thermophilic bacteria. *Adv Biochem Eng Biotechnol* 38:1–52
- Lynd LR, Cushman JH, Nichols RJ, Wyman CE (1991) Fuel ethanol from cellulosic biomass. *Science* 251:1318–1323
- Lynd LR, Baskaran S, Casten S (2001) Salt accumulation resulting from base added for pH control, and not ethanol, limits growth of *Thermoanaerobacterium thermosaccharolyticum* HG-8 at elevated feed xylose concentrations in continuous culture. *Biotechnol Prog* 17:118–125
- Lyon WJ, Glatz BA (1995) Propionibacteria. In: Hui YH, Khachatourians GG (eds) *Food biotechnology, microorganisms*. VCH, New York, pp 703–719
- Mackenzie KF, Eddy CK, Ingram LO (1989) Modulation of alcohol dehydrogenase isoenzyme levels in *Zymomonas mobilis* by iron and zinc. *J Bacteriol* 171:1063–1067
- Mai V, Wiegel J (2000) Advances in development of a genetic system for *Thermoanaerobacterium* spp.: expression of genes encoding hydrolytic enzymes, development of a second shuttle vector, and integration of genes into chromosome. *Appl Environ Microbiol* 66:4817–4821
- Mai V, Lorenz WW, Wiegel J (1997) Transformation of *Thermoanaerobacterium* sp. strain JW/SL-YS485 with plasmid pIKM1 conferring kanamycin resistance. *FEMS Microbiol Lett* 148:163–167
- Martin ME, Wayman M, Graf G (1961) Fermentation of sulfite waste liquor to produce organic acids. *Can J Microbiol* 7:341–346
- McCoy M (1998) Biomass ethanol inches forward. *Chem Eng News* 76:29–32
- McLellan PJ, Daugulis AJ, Li J (1999) The incidence of oscillatory behavior in the continuous fermentation of *Zymomonas mobilis*. *Biotechnol Prog* 15:667–680
- Mermelstein LD, Welker NE, Petersen DJ, Bennett GN, Papoutsakis ET (1994) Genetic and metabolic engineering of *Clostridium acetobutylicum*. ATCC 824. *Ann NY Acad Sci* 721:54–68
- Michel-Savin D, Marchal R, Vandecasteele JP (1990a) Control of the selectivity of butyric acid production and improvement of fermentation performance with *Clostridium tyrobutyricum*. *Appl Microbiol Biotechnol* 32:387–392
- Michel-Savin D, Marchal R, Vandecasteele JP (1990b) Butyrate production in continuous culture of *Clostridium tyrobutyricum*. *Appl Microbiol Biotechnol* 33:127–131
- Michel-Savin D, Marchal R, Vandecasteele JP (1990c) Butyric fermentation: metabolic behavior and production performance of *Clostridium tyrobutyricum* in a continuous culture with cell recycle. *Appl Microbiol Biotechnol* 34:172–177
- Minton NP, Brehm JK, Swinfield TJ, Whelan SW, Mauchline ML, Bodsworth N, Oultrum JD (1993) Clostridial cloning vectors. In: Woods DR (ed) *The clostridia and biotechnology*. Butterworth-Heinemann, London, pp 120–150
- Mishra P, Kaur S (1991) Lipids as modulators of ethanol tolerance in yeast. *Appl Microbiol Biotechnol* 34:697–702
- Morris JG (1993) History and future potential of the clostridia in biotechnology. In: Woods DR (ed) *The clostridia and biotechnology*. Butterworth-Heinemann, London, pp 1–23
- Nair RV, Bennett GN, Papoutsakis ET (1994) Molecular characterization of an alcohol/aldehyde dehydrogenase gene of *Clostridium acetobutylicum* ATCC 824. *J Bacteriol* 176:871–885
- Nakano MM, Dailly YP, Zuber P, Clark DP (1997) Characterization of anaerobic fermentative growth of *Bacillus subtilis*: identification of fermentation end products and genes required for growth. *J Bacteriol* 179:6749–6755
- Neale AD, Scopes RK, Kelly JM, Wettenhall REH (1986) The two alcohol dehydrogenases of *Zymomonas mobilis*: purification by differential dye ligand chromatography, molecular characterisation and physiological roles. *Eur J Biochem* 154:119–124
- Neale AD, Scopes RK, Wettenhall REH, Hoogenraad NJ (1987) Nucleotide sequence of the pyruvate decarboxylase gene from *Zymomonas mobilis*. *Nucleic Acids Res* 15:1753–1761
- Neale AD, Scopes RK, Kelly JM (1988) Alcohol production from glucose and xylose using *Escherichia coli* containing *Zymomonas mobilis* genes. *Appl Microbiol Biotechnol* 29:162–167
- Nishikawa M, Brancon RMR, Pinder KL, Strasline GA (1970) Fermentation of spent sulfite liquor to produce acetic acid, propionic acid and vitamin B12. *Pulp and Paper Magazine of Canada* 71(3):T59–T64
- Nölling J, Breton G, Omelchenko MV, Markarova KS, Zeng Q, Gibson R, Lee HM, DuBois J, Qiu D, Hitti J, GTC Sequencing Center Production, Finishing, and Bioinformatics Teams, Wolf YI, Tatusov RL, Sabathe F, Doucette-Stamm L, Soucaille P, Daly MJ, Bennett GN, Koonin EV, Smith DR (2001) Genome sequence and comparative analysis of the solvent-producing bacterium *Clostridium acetobutylicum*. *J Bacteriol* 183:4823–4838
- Ohta K, Beall DS, Mejia JP, Shanmugam KT, Ingram LO (1991a) Genetic improvement of *Escherichia coli* for ethanol production: chromosomal integration of *Zymomonas mobilis* genes encoding pyruvate decarboxylase and alcohol dehydrogenase I. *Appl Environ Microbiol* 57:893–900
- Ohta K, Beall DS, Mejia JP, Shanmugam KT, Ingram LO (1991b) Metabolic engineering of *Klebsiella oxytoca* M5A1 for ethanol production from xylose and glucose. *Appl Environ Microbiol* 57:2810–2815
- O'Mullan PJ, Buchholz SE, Chase T Jr, Eveleigh DE (1995) Roles of alcohol dehydrogenases of *Zymomonas mobilis* (ZADH): characterization of a ZADH-2-negative mutant. *Appl Microbiol Biotechnol* 43:675–678
- Paik HD, Glatz BA (1994) Propionic acid production by immobilized cells of a propionate-tolerant strain of *Propionibacterium acidipropionici*. *Appl Microbiol Biotechnol* 42:22–27
- Palosaari NR, Rogers P (1988) Purification and properties of the inducible coenzyme A-linked butyraldehyde dehydrogenase from *Clostridium acetobutylicum*. *J Bacteriol* 170:2971–2976
- Papanikolaou S, Ruiz-Sanchez P, Pariset B, Blanchard F, Fick M (2000) High production of 1,3-propanediol from industrial glycerol by a newly isolated *Clostridium butyricum* strain. *J Biotechnol* 77:191–208
- Papoutsakis ET, Bennett GN (1993) Cloning, structure, and expression of acid and solvent pathway genes of *Clostridium acetobutylicum*. In: Woods DR (ed) *The clostridia and biotechnology*. Butterworth-Heinemann, London, pp 157–200
- Papoutsakis ET, Bennett GN (1999) Molecular regulation and metabolic engineering of solvent production by *Clostridium acetobutylicum*. In: Papoutsakis ET, Lee SY (eds) *Bioprocess technology*, vol 24. Marcel Dekker, New York, pp 253–279
- Pasteur L (1861a) Animalcules infusoires vivant sans gaz oxygène libre et déterminant des fermentations. *Comp Rend* 52:344–347
- Pasteur L (1861b) Mémoire sur les corpuscles organisés qui existent dans l'atmosphère: Esamen de la doctrine des générations spontanées. *Ann Sci Nat* 16:5–98, 4th series
- Pasteur L (1879) *Studies on fermentation*. Macmillan, London
- Peretz M, Bogin O, Tel-Or S, Cohen A, Li G, Chen J-S, Burstein Y (1997) Molecular cloning, nucleotide sequencing, and expression of genes encoding alcohol dehydrogenase from the thermophile *Thermoanaerobacter Brockii* and the mesophile *Clostridium beijerinckii*. *Anaerobe* 3:259–270
- Perozich J, Nicholas H, Wang BC, Lindahl R, Hempel J (1999) Relationships within the aldehyde dehydrogenase extended family. *Protein Sci* 8:137–146
- Petitdemange H, Cherrier C, Raval G, Gay R (1976) Regulation of NADH and NADPH ferredoxin oxidoreductases in clostridia of the butyric group. *Biochem Biophys Acta* 421:334–347
- Philips JR, Clausen EC, Gaddy JL (1994) Synthesis gas as substrate for the biological production of fuels and chemicals. *Appl Biochem Biotechnol* 45–46:145–157
- Piveteau P (1999) Metabolism of lactate and sugars by dairy propionibacteria: a review. *Lait* 79:23–41
- Playne MJ (1985) Propionic acid and butyric acid. In: Moo-Young M (ed) *Comprehensive biotechnology*. Pergamon, New York, pp 731–755

- Prescott SC, Dunn CG (1949) Industrial microbiology, 2nd edn. McGraw-Hill, New York, pp 477–486
- Quesada-Chanto A, Afschar AS, Wagner F (1994a) Microbial production of propionic acid and vitamin B-12 using molasses or sugar. *Appl Microbiol Biotechnol* 41:378–383
- Quesada-Chanto A, Afschar AS, Wagner F (1994b) Optimization of a *Propionibacterium acidipropionici* continuous culture utilization of sucrose. *Appl Microbiol Biotechnol* 42:16–21
- Quesada-Chanto A, da Costa JPCL, Silveira MM, Schroeder AG, Schmidt-Meyer AC, Jona R (1998a) Influence of different vitamin-nitrogen sources on cell growth and propionic acid production from sucrose by *Propionibacterium shermanii*. *Acta Biotechnologia* 18:267–274
- Quesada-Chanto A, Silveira MM, Schmidt-Meyer AC, Schroeder AG, da Costa JPCL, Lopez J, Carvalho-Jonas MF, Artolozaga MJ, Jona R (1998b) Effect of oxygen supply on pattern of growth and corrinoid and organic acid production of *Propionibacterium shermanii*. *Appl Microbiol Biotechnol* 49:732–736
- Ragsdale SW, Riordan CG (1996) The role of nickel in acetyl-CoA synthesis by the bifunctional enzyme CO dehydrogenase/acetyl-CoA synthase: enzymology and model chemistry. *J Biol Inorg Chem* 1:489–493
- Rani KS, Seenayya G (1999) High ethanol tolerance of new isolates of *Clostridium thermocellum* strains SS21 and SS22. *World J Microbiol Biotechnol* 15:173–178
- Reed G (1982) Production of fermentation alcohol as a fuel source. In: Reed G (ed) Prescott & Dunn's industrial microbiology, 4th edn. AVI Publishing, Westport, pp 835–859
- Rehberger JL, Glatz BA (1998) Response of cultures of *Propionibacterium* to acid and low pH tolerance and inhibition. *J Food Protect* 61:211–216
- Reid MF, Fewson CA (1994) Molecular characterization of microbial alcohol dehydrogenases. *Crit Rev Microbiol* 20:13–56
- Reynen M, Sahn H (1988) Comparison of the structural genes for pyruvate decarboxylase in different *Zymomonas mobilis* strains. *J Bacteriol* 170:3310–3313
- Reysset G, Sebald M (1993) Transformation/electrotransformation of clostridia. In: Woods DR (ed) The clostridia and biotechnology. Butterworth-Heinemann, London, pp 151–158
- Rickert DA, Glatz CE, Glatz BA (1998) Improved organic acid production by calcium alginate-immobilized propionibacteria. *Enzyme Microb Technol* 22:409–414
- Rogers P (1999) Clostridia: solvent formation. In: Flickinger MC, Drew SW (eds) Encyclopedia of bioprocess technology: fermentation, biocatalysis and bioseparation, vol 2. Wiley, New York, pp 670–687
- Rogers P, Gottschalk G (1993) Biochemistry and regulation of acid and solvent production in clostridia. In: Woods DR (ed) The clostridia and biotechnology. Butterworth-Heinemann, Stoneham, pp 25–50
- Rogers PL, Lee KJ, Skotnicki ML, Tribe DE (1982) Ethanol production by *Zymomonas mobilis*. *Adv Biochem Eng* 23:37–84
- Rogers PL, Lee KJ, Smith GM, Barrow KD (1989) Ethanol tolerance of *Zymomonas mobilis*. In: van Uden N (ed) Alcohol toxicity in yeasts and bacteria. CRC Press, Boca Raton, pp 239–256
- Rudolph FB, Purich DL, Fromm HJ (1968) Coenzyme A-linked aldehyde dehydrogenase from *Escherichia coli*. I: partial purification, properties, and kinetic studies of the enzyme. *J Biol Chem* 243:5539–5545
- Saint-Amans S, Girbal L, Andrade J, Ahrens K, Soucaille P (2001) Regulation of carbon and electron flow in *Clostridium butyricum* VP 13266 g grown on glucose-glycerol mixtures. *Bacteriol* 183:1748–1754
- Sauer ET (1991) Carboxylic acids (economic aspects). In: Encyclopedia of chemical technology, vol 5, 4th edn. Wiley, New York, pp 179–187
- Sauer U, Santangelo JD, Trever A, Bucholz M, Dürre P (1995) Sigma factor and sporulation genes in *Clostridium*. *FEMS Microbiol Rev* 17:331–340
- Scopes RK (1983) An iron-activated alcohol dehydrogenase. *FEBS Lett* 156:303–306
- Sheehan J (2000) The road to bioethanol: a strategic perspective of the U.S. Department of Energy's national ethanol program. In: HM E, Baker JO, Saddler JN (eds) Glycosyl hydrolases for biomass conversion, vol 769. American Chemical Society, Washington, DC, pp 2–25, ACS Symposium Series
- Shen GJ, Annons BA, Lovitt RW, Jain MK, Zeikus JG (1996) Biochemical route and control of butyrate synthesis in *Butyribacterium methylotrophicum*. *Appl Microbiol Biotechnol* 45:355–362
- Sherman JM, Shaw RH (1923) Process for the production of propionates and propionic acid. US Patent 1,470,885 Chem Abstr 18:146
- Shoham Y, Lamed R, Bayer EA (1999) The cellulosome concept as an efficient microbial strategy for the degradation of insoluble polysaccharides. *Trends Microbiol* 7:275–281
- Shone CC, Fromm HJ (1981) Steady-state and pre-steady-state kinetics of coenzyme A linked aldehyde dehydrogenase from *Escherichia coli*. *Biochemistry* 20:7494–7501
- Silveira MM, Wisbeck E, Hoch I, Jonas R (2001) Production of glucose-fructose oxidoreductase and ethanol by *Zymomonas mobilis* ATCC 29191 in medium containing corn steep liquor as a source of vitamins. *Appl Microbiol Biotechnol* 55:442–445
- Sinskey AJ, Akedo M, Cooney CL (1981) Acrylate fermentations. In: Hollaender A (ed) Trends in the biology of fermentations. Plenum Press, New York, pp 473–492
- Slapack GE, Russell I, Stewart GG (1987) Thermophilic microbes in ethanol production. CRC Press, Boca Raton
- Société Lefranc et Cie. (1925) An improved process for the manufacture of dipropylketone. British Patent 216–120. Chem Abstr 19:77
- Solichien MS, O'Brien D, Hammond EG, Glatz CE (1995) Membrane-based extractive fermentation to produce propionic and acetic acids: toxicity and mass transfer considerations. *Enzyme Microb Technol* 17:23–31
- Strecker A (1854) Über eine eigentümliche Bildungsweise der Propionsäure und einige Salze derselben. *Ann Chem* 92:80
- Swick RW, Wood HG (1960) The role of transcarboxylation in propionic acid fermentation. *Proc Natl Acad Sci USA* 46:28–41
- Swings J, De Ley J (1977) The biology of *Zymomonas*. *Bacteriol Rev* 41:1–46
- Swings J, De Ley J (1984) Genus *Zymomonas*. In: Krieg NR, Holt JG (eds) [http://www.cme.msu.edu/bergeys] Bergey's Manual of Systematic Bacteriology]. Williams and Wilkins, Baltimore 1:576–580
- Tanner RS, Miller LM, Yang D (1993) *Clostridium ljungdahlii* sp. nov., an acetogenic species in clostridial rRNA homology group I. *Int J Syst Bacteriol* 43:232–236
- Thauer RK, Jungerman K, Decker K (1977) Energy conservation in chemotrophic anaerobic bacteria. *Bacteriol Rev* 41:100–180
- Thayer A (2000) Challenges of a biobased economy. *C & EN* 29:40
- Thomas SR, Adney WS, Baker JO, Chou Y-C, Himmel ME (1997) US Patent 5,712,142
- Tolan JS, Finn RK (1987) Fermentation of D-xylose and L-arabinose to ethanol by *Erwinia chrysanthemi*. *Appl Environ Microbiol* 53:2033–2044
- Toth J, Ismael AA, Chen J-S (1999) Purification of a coenzyme A-acylating aldehyde dehydrogenase and cloning of the structural gene from *Clostridium beijerinckii* NRRL B593. *Appl Environ Microbiol* 65:4973–4980
- Uchida K (1974) Lipids of alcoholophilic lactobacilli. II: occurrence of polar lipids with unusually long acyl chains in *Lactobacillus heterochiochii*. *Biochim Biophys Acta* 369:146–155
- Uchida K (1975a) Alteration of the unsaturated to saturated ratio of fatty acids in bacterial lipids by alcohols. *Agric Biol Chem* 39:1515–1516
- Uchida K (1975b) Effects of cultural conditions on the cellular fatty acid composition of *Lactobacillus heterochiochii*, an alcoholophilic bacterium. *Agric Biol Chem* 39:837–842
- Van An del JG, Zoutberg GR, Crabbendam PM, Breure AM (1985) Glucose fermentation by *Clostridium butyricum* grown under a self-generated gas atmosphere in chemostat culture. *Appl Microbiol Biotechnol* 23:21–26
- Van Niel CB (1928) The propionic acid bacteria (thesis) Laboratorium voor Microbiologie der Technische Hoogeschool Delft, N.V. Uitgeverszaak, J. W. Boissevain & Co Haarlem, The Netherlands
- Vandak D, Telgarsky M, Sturkik E (1995a) Influence of growth factor components on butyrate production from sucrose by *Clostridium butyricum*. *Folia Microbiol* 40:32–42
- Vandak D, Zigova TM, Sturdik E (1995b) Effect of growth supplements and whey pretreatment on butyric acid production by *Clostridium butyricum*. *World J Microbiol Biotechnol* 11:363

- Vandak D, Zigova J, Sturdik E, Schlosser S (1997) Evaluation of solvent and pH for extractive fermentation of butyric acid. *Process Biochem* 32:245–251
- Varadarajan S, Miller DJ (1999) Catalytic upgrading of fermentation-derived organic acids. *Biotechnol Prog* 15:845–854
- Vega JL, Prieto S, Elmore BB, Clausen EC, Gaddy JL (1989) The biological production of ethanol from synthesis gas. *Appl Biochem Biotechnol* 20/21:781–797
- Vollbrecht D, El Nawawy MA (1980) Restricted oxygen supply and excretion of metabolites. *Euro J Appl Microbiol Biotechnol* 9:1–8
- Von Freudenreich E, Jensen O (1906) Über die im Emmentaler Käse stattfindende Propionsäuregärung Zentralblatt für Bacteriologie. Parasiten Kunde Infectious Krankheiten und Hygiene Abt II 17:529–546
- Wayman M, Martin ME, Graf G (1962) Propionic acid fermentation. US Patent 3,067,107. *Chem Abstr* 58:7337
- Weber GH, Broich WA (1986) Shelf life extension of cultured dairy foods. *Cult Dairy Prod J* 21(4):19–23
- Weiss N, Schillinger U, Kandler O (1983) *Lactobacillus trichodes* and *Lactobacillus heterochiochii*, subjective synonym of *Lactobacillus fructivorans*. *Syst Appl Microbiol* 4:507–511
- Wiegel J (1980) Formation of ethanol by bacteria. A pledge for the use of extreme thermophilic anaerobic bacteria in industrial ethanol fermentation processes. *Experientia* 36:1434–1446
- Wiegel J (1992) The obligately anaerobic thermophilic bacteria. In: Kristjansson JK (ed) *Thermophilic bacteria*. CRC Press, Boca Raton, pp 105–184
- Wiegel J, Ljungdahl LG (1986) The importance of thermophilic bacteria in biotechnology. *Crit Rev Biotechnol* 3:39–108
- Wilkinson SR, Young DI, Morris JG, Young M (1995) Molecular genetics and the initiation of solventogenesis in *Clostridium beijerinckii* (formerly *Clostridium acetobutylicum*) NCIMB 8052. *FEMS Microbiol Rev* 17:275–285
- Wills C, Kratofil P, Londo D, Martin T (1981) Characterization of the two alcohol dehydrogenases of *Zymomonas mobilis*. *Arch Biochem Biophys* 210:775–785
- Winston SJ, Solar Energy Information Data Bank (1981) *Ethanol fuels: use, production & economics*, 1st edn. US Government Printing Office, Golden
- Wood BE, Ingram LO (1992) Ethanol production from cellobiose, amorphous cellulose, and crystalline cellulose by recombinant *Klebsiella oxytoca* containing chromosomally integrated *Zymomonas mobilis* genes for ethanol production and plasmids expressing thermostable cellulase genes from *Clostridium thermocellum*. *Appl Environ Microbiol* 58:2103–2110
- Worden RM, Grethlein AJ, Zeikus JG, Datta R (1989) Butyrate production from carbon monoxide by *Butyribacterium methylotrophicum*. *App Biochem Biotechnol* 20/21:687–698
- Worden RM, Grethlein AJ, Jain MK, Datta R (1991) Production of butanol and ethanol from synthesis gas via fermentation. *Fuel* 70:615–619
- Worden RM, Bredwell MD, Grethlein AJ (1997) Engineering issues in synthesis-gas fermentations. In: Saha BC, Woodward J (eds) *Fuels and chemicals from biomass*, vol 666. American Chemical Society, Washington, DC, pp 320–335, ACS Symposium Series
- Woskow SA, Glatz BA (1991) Propionic acid production by a propionic acid tolerant strain of *Propionibacterium acidipropionici* in batch and semicontinuous fermentation. *Appl Environ Microbiol* 57:2821–2828
- Wyman CE (1994) Ethanol from lignocellulosic biomass: technology, economics, and opportunities. *Bioresource Technol* 50:3–16
- Wyman CE (ed) (1996) *Handbook on bioethanol: production and utilization*. Taylor and Francis, Washington, DC
- Wyman CE (2001) Twenty years of trials, tribulations and research progress in bioethanol technology. *Appl Biochem Biotechnol* 91–93:5–21
- Xue Y, Xu Y, Liu Y, Ma Y, Zhou P (2001) *Thermoanaerobacter tengcongensis* sp. nov., a novel anaerobic, saccharolytic, thermophilic bacterium isolated from a hot spring in Tongcong, China. *Int J Syst Evol Microbiol* 51:1335–1341
- Yan R-T, Chen J-S (1990) Coenzyme A-acylating adlehyde dehydrogenase from *Clostridium beijerinckii* NRRL B592. *Appl Environ Microbiol* 56:2591–2599
- Yang ST, Zhu H, Li Y, Hong G (1994) Continuous propionate production from whey permeate using a novel fibrous bed bioreactor. *Biotechnol Bioeng* 43:1124–1130
- Yomano LP, York SW, Ingram LO (1998) Isolation and characterization of ethanol-tolerant mutants of *Escherichia coli* KO11 for fuel ethanol production. *J Ind Microbiol Biotechnol* 20:132–138
- Yoon K-H, Pack MY (1990) Nucleotide sequence of the *Zymomonas mobilis* alcohol dehydrogenase II gene. *Nucleic Acids Res* 18:187
- Young M (1993) Development and exploitation of conjugative gene transfer in clostridia. In: Woods DR (ed) *The clostridia and biotechnology*. Butterworth-Heinemann, London, pp 99–118
- Zakpaa HD, Ishizaki A, Shimizu K (1997) Computer-mediated addition of fresh medium in continuous culture of *Zymomonas mobilis* by monitoring weight changes. In: Saha BC, Woodward J (eds) *Fuels and chemicals from biomass*, vol 666. American Chemical Society, Washington, DC, pp 143–154, ACS Symposium Series
- Zanin GM, Santana CC, Bon EPS, Giordano RCL, de Moraes FF, Andrietta SR, de Carvalho Neto CC, Macedo IC, Fo DL, Ramos LP, Fontana JD (2000) Brazilian bioethanol program. *Appl Biochem Biotechnol* 84–86:1147–1161
- Zhang M, Eddy C, Deanda K, Finkelstein M, Picataggio S (1995) Metabolic engineering of a pentose metabolism pathway in ethanologenic *Zymomonas mobilis*. *Science* 267:240–243
- Zigova J, Sturdik E (2000) Advances in biotechnological production of butyric acid. *J Ind Microb Biotechnol* 24:153–160
- Zigova J, Sturdik E, Vandak D, Schlosser S (1999) Butyric acid production by *Clostridium butyricum* with integrated extraction and pertraction. *Process Biochem* 34:835–843

4 Amino Acid Production

Hidehiko Kumagai

Ishikawa Prefectural University, Nonoichi-shi, Ishikawa-ken, Japan

Introduction	169
L-Alanine	169
L-Aspartate	170
L-Cysteine	171
L-DOPA	171
L-Glutamic Acid	172
D-p-Hydroxyphenylglycine	173
Hydroxy-L-proline	174
L-Lysine	174
L-Threonine	175

Abstract

Since microbial production of L-glutamic acid was started in 1957 in Japan, various amino acids production with microorganisms has been developed and almost all protein-constitutive amino acids become able to be produced by microbial biotechnology, fermentation, or enzymatic method. This chapter summarizes the microbial biotechnology which was developed and industrialized in Japan. The amino acids include L-alanine, L-cysteine, L-DOPA, L-glutamic acid, D-p-hydroxyphenylglycine, hydroxy-L-proline, L-lysine and L-threonine.

Introduction

The water extract of a marine algae “kelp” (*Laminaria japonica*) has been used in a number of Japanese recipes as a kind of soup to flavor cooking. The tasty (“umami” in Japanese) factor in the marine algae was identified as monosodium glutamate by Prof. Kikunae Ikeda in 1908. Soon thereafter, Ajinomoto Co. Ltd. started to produce monosodium glutamate by extraction from wheat protein after hydrolysis with hydrochloric acid.

In 1956, Kyowa Hakko Kogyo Co. Ltd. succeeded in producing sodium glutamate by using a bacterium (*Corynebacterium glutamicum*). Then, production using microbial methods of various amino acids (including of L-alanine, L-aspartic acid, L-arginine, L-citrulline, L-cysteine, L-DOPA [3,4-dihydroxyphenylalanine], L-glutamic acid, L-glutamine, glutathione, L-histidine,

D-hydroxyphenylglycine, L-hydroxyproline, L-isoleucine, L-lysine, L-ornithine, L-phenylalanine, D-phenylglycine, L-polylysine, L-proline, L-serine, L-threonine, L-tryptophan, and L-tyrosine) was investigated and successfully manufactured on an industrial scale. Glycine is produced by chemical methods because the molecule has no chiral center, and methionine is also produced by chemical methods in its racemic form because the main use of the amino acid is as feedstuff. D-Methionine is metabolized in animals by the action of D-amino acid oxidase. These amino acids were useful as sources of medicines, food additives, feed-stuffs, and starting materials for chemical synthesis.

The microbial methods for the production of amino acids are either fermentative or enzymatic. Fermentation methods use cheap carbon and nitrogen sources as the starting materials to produce rather large amounts of amino acids. These starting materials are metabolized by a number of enzymatic reaction steps, and the product accumulates in the culture medium during cell growth. Enzymatic methods require substrates that are generally expensive because they usually are produced by chemical synthesis. So this method is suitable for rather expensive, small-scale production.  [Figure 4.1](#) shows the difference between fermentative and enzymatic methods.

This chapter describes the microbial production of some amino acids including the producing strains, production method, product usage, and industrial production.

L-Alanine

The annual world production of L-alanine is about 500 t. This amino acid is useful as an enteral and parenteral nutrient and as a food additive, which has a sweet taste and bacteriostatic properties.

L-Alanine is produced from L-aspartate by a one-step enzymatic method using aspartate β -decarboxylase (Chibata et al. 1986a) ( [Fig. 4.2](#)).

L-Alanine production by fermentation is difficult because bacteria usually have an alanine racemase to racemize the product. Fermentative production of L-alanine with racemase-deficient strains of *Corynebacterium glutamicum*, *Brevibacterium flavum*, and *Arthrobacter oxydans* (Hashimoto and Katsumata 1999) has been investigated, and good yields have been reported, although the method is not yet industrially applicable.

Tanabe Seiyaku Co. in Japan applied on an industrial scale the enzymatic method described above, using aspartic acid produced by immobilized enzymes as the starting material. A bacterial strain selected for its strong aspartate β -decarboxylase

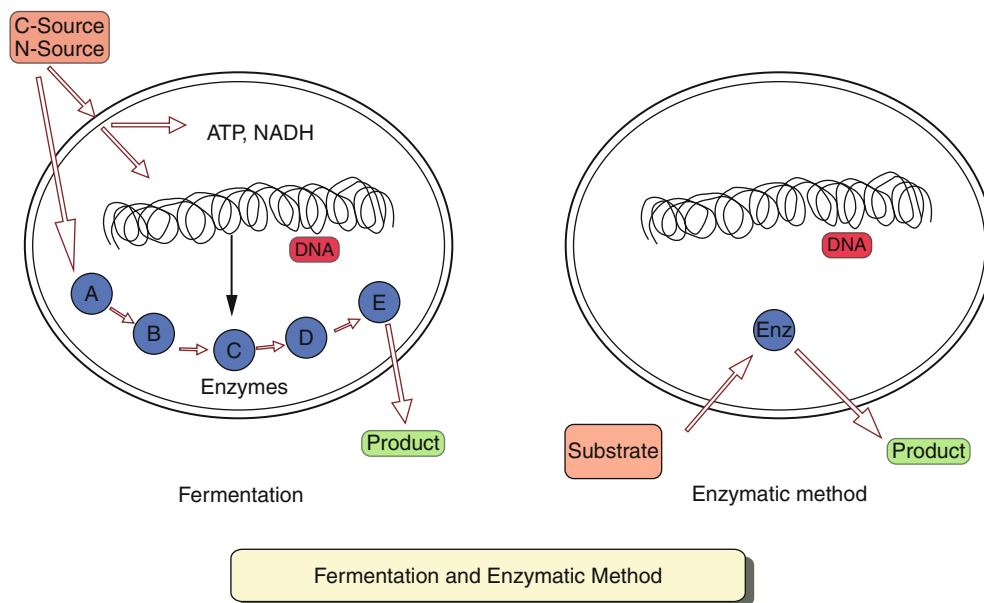

Fig. 4.1
Fermentation and enzymatic methods

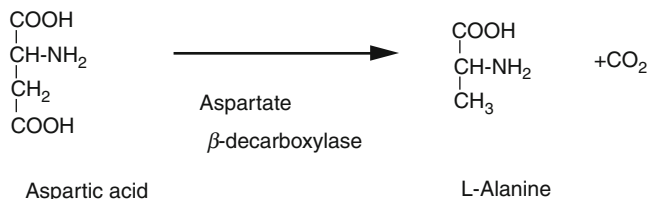

Fig. 4.2
Enzymatic synthesis of L-alanine

activity was identified as *Pseudomonas dacunhae* (Chibata et al. 1965). The bacterial cells with high activity were immobilized on κ-carrageenan, a polysaccharide obtained from seaweed, and packed in a column. The L-alanine was produced by this column system continuously. To prevent the evolution of carbon dioxide gas, a closed column reactor was designed and used for the production. In this column, the enzyme reaction proceeds under high pressure (Chibata et al. 1986a).

The substrate, L-aspartate, is produced from fumarate by an enzyme system involving aspartase, as described in the section on L-aspartate. To produce L-alanine directly from fumarate, the L-alanine-producing column was connected in tandem to an L-aspartate-producing column. In this tandem column system, side reactions caused by fumarase in *Escherichia coli* and alanine racemase in *P. dacunhae* reduced the yield. Then, both bacterial cells were separately treated with high temperature and low pH, respectively, and the enzymes responsible for the side reactions were inactivated. Immobilization of these two kinds of bacterial cells with κ-carrageenan resulted in the production of L-alanine in a single reactor without the production of the side products, malate and D-alanine (Takamatsu et al. 1982; Chibata et al. 1986b).

L-Aspartate

The annual world production of L-aspartate is estimated to be 7,000 t. L-Aspartate is used as an enteral and parenteral nutrient, a food additive, and a starting material for the low-calorie sweetener aspartame (aspartylphenylalanine methyl ester). It is also used as a raw material to synthesize detergent and for chelating or water treatment agents.

L-Aspartate is produced by the reaction of fumarate and ammonia catalyzed by aspartase.

L-Aspartate production began in 1960 using a batchwise process involving *E. coli* cells containing high aspartase activity. In 1973, Chibata and collaborators at the Tanabe Seiyaku Co. started producing L-aspartate using a continuous reaction system consisting of an immobilized enzyme column. In the system, aspartase extracted from *E. coli* cells was immobilized on ion exchange resin. *Escherichia coli* cells were immobilized by trapping in acrylamide gel, and then, the column was used in industrial production (Tosa et al. 1973). In 1978, this matrix was changed to κ-carrageenan. The production of L-aspartate was greatly improved by this method, and the yield became 100 t/month using a 1 kl bioreactor (Chibata et al. 1986b). In the United States, *E. coli* cells with high aspartase activity immobilized on polyurethane and polyazetidine were reported, and the latter was shown to have high aspartase activity, producing aspartate at the rate of 55.9 mol/h/kg cell (wet weight; Fusee et al. 1981).

A different system for the enzymatic production of L-aspartate was proposed and used by Mitsubishi Petrochemical Co. in Japan in 1985. In this system, resting intact coryneform bacteria, *Brevibacterium flavum*, were used without immobilization in a reactor with an ultrafiltration membrane (Terasawa et al. 1985). The starting material, maleate, was converted to fumarate

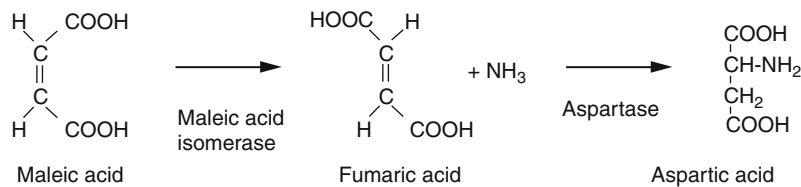

■ Fig. 4.3
Enzymatic synthesis of L-aspartate

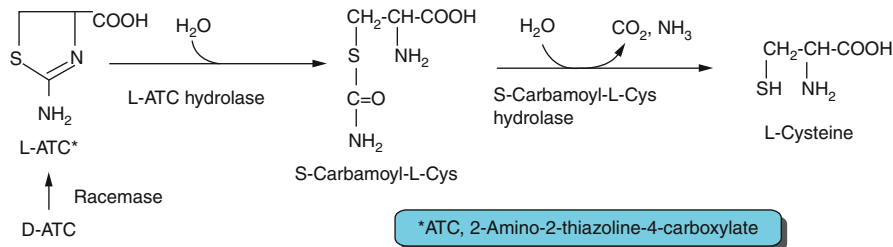

■ Fig. 4.4
Enzymatic synthesis of L-cysteine

by maleate isomerase in the cells. The bacterial strain with high maleate isomerase and aspartase activity was obtained by the transformation of its genes. The plasmids introduced were stabilized (Zupansic et al. 1995), and the cells were reused many times without any loss of activity and lysis (Yukawa 1999) (► Fig. 4.3).

L-Cysteine

Annual world production of L-cysteine is 1,500 t. Its uses are as an enteral and parenteral nutrient, food additive, constituent of hair treatment preparations, and starting material of constituents used in cosmetics.

In 1982, Ajinomoto Co. Ltd. industrially applied a three-step enzymatic process to produce L-cysteine from DL-2-amino-2-thiazoline-4-carboxylate (DL-ATC), a starting material of the chemical synthesis of L-cysteine. The enzymes catalyzing this process are DL-ATC racemase, L-ATC hydrolase, and S-carbamoyl-L-cysteine (SCC) hydrolase (Sano et al. 1977, 1979; Sano and Mitsugi 1978; ► Fig. 4.4).

S-Carboxymethyl-L-cysteine is also produced by the same enzymatic method from the corresponding starting material (Yokozeki et al. 1988).

In screening for high-yield producers, the bacterial strain that produced the most L-cysteine from DL-ATC was isolated from soil and designated "*Pseudomonas thiazolinophilum*." The enzymes responsible for the conversion were inducible, and the addition of DL-ATC to the culture medium was essential for enzyme activity. Addition of Mn^{+2} and Fe^{+2} to the medium also contributed to increasing the enzyme activity. The reaction proceeds by adding cells with high enzyme activities but no cysteine-desulhydrase (an L-cysteine-degrading enzyme) to the

reaction mixture containing DL-ATC. L-Cysteine produced in the reaction mixture is oxidized to L-cystine by aeration and precipitated as crystals. This increases the efficiency of L-cysteine production, which is 31.4 g/l obtained from 40 g/l of DL-ATC, i.e., 95 % product yield by molar ratio.

L-DOPA

The annual world production of L-DOPA is around 250 t. L-DOPA (the precursor of the neurotransmitter dopamine) is useful as a treatment for Parkinson's disease. It had been mainly produced by a chemical synthetic method that included eight reaction steps including an optical resolution step.

L-DOPA is produced from pyrocatechol, pyruvate, and ammonia by a one-step enzyme reaction using tyrosine phenol-lyase (TPL). Ajinomoto Co. Ltd. began using *Erwinia* TPL for enzymatic L-DOPA production (by a simple one-step method and one of the most economical processes to date) in 1993.

Tyrosine phenol-lyase (TPL) is a pyridoxal 5'-phosphate-dependent multifunctional enzyme and catalyzes degradation of tyrosine into phenol, pyruvate, and ammonia. This reaction is reversible, and the reverse reaction is available to produce L-DOPA using pyrocatechol instead of phenol (► Fig. 4.5).

Erwinia herbicola was selected as the most favorable strain for the L-DOPA production out of 1,041 microbial strains tested. No enzyme activity was found in yeasts, fungi, and actinomycetes. Culture conditions for the preparation of cells containing high TPL activity and reaction conditions for the synthesis of L-DOPA were optimized with *Erwinia herbicola*. Additions of yeast extract, meat extract, polypeptone, and the hydrolyzate of soybean protein to the basal medium enhanced cell growth as well as the formation of TPL. Catabolite repression of

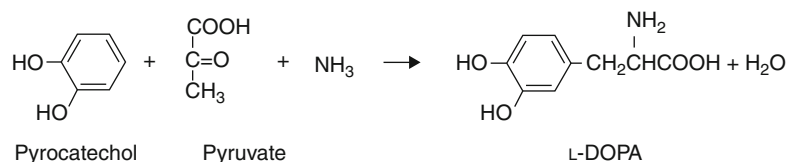

■ Fig. 4.5

Enzymatic synthesis of L-3,4-dihydroxyphenylalanine (DOPA)

biosynthesis of TPL was observed on adding glucose, pyruvate, and α -ketoglutarate to the medium at high concentrations. Glycerol was a suitable carbon source for cell growth as well as for the accumulation of the enzyme in growing cells. TPL is an inducible enzyme, and the addition of L-tyrosine to the medium is essential for formation of the enzyme. L-Phenylalanine is not an inducer of TPL biosynthesis but works as a synergistic agent for the induction by L-tyrosine. The activity of TPL increased five times by the addition of L-phenylalanine together with L-tyrosine to the medium. Cells of *E. herbicola* with high TPL activity were prepared by growing them at 28 °C for 28 h in a medium containing 0.2 % KH_2PO_4 , 0.1 % $\text{MgSO}_4 \cdot 7\text{H}_2\text{O}$, 2 ppm of Fe^{+2} ($\text{FeSO}_4 \cdot 7\text{H}_2\text{O}$), 0.01 % pyridoxine-HCl, 0.6 % glycerol, 0.5 % succinic acid, 0.1 % DL-methionine, 0.2 % DL-alanine, 0.05 % glycine, 0.1 % L-phenylalanine, and 12 ml of hydrolyzed soybean protein in 100 ml of tap water, with the pH controlled at 7.5 throughout cultivation. Under these conditions, TPL was efficiently accumulated in the cells of *E. herbicola* and made up about 10 % of the total soluble cellular protein (Yamada and Kumagai 1975).

The enzymatic synthesis reaction of L-DOPA is carried out in a batchwise system with cells of *E. herbicola* containing high activity of TPL. Since pyruvate, one of the substrates, was unstable in the reaction mixture at high temperature, low temperature was used for the synthesis of L-DOPA. The reaction was carried out at 16 °C for 48 h in a reaction mixture containing various amounts of sodium pyruvate, 5 g of ammonium acetate, 0.6 g of pyrocatechol, 0.2 g of sodium sulfite, 0.1 g of EDTA, and cells harvested from 100 ml of broth in a total volume of 100 ml. The pH was adjusted to 8.0 by the addition of ammonia. At 2-h intervals, sodium pyruvate and pyrocatechol were added to the reaction mixture to maintain the initial concentrations. The maximum synthesis of L-DOPA was obtained when the concentration of sodium pyruvate was kept at 0.5 %. The addition of substrates, pyrocatechol and pyruvate, was separated by a time interval to prevent the denaturation of TPL and to prevent by-product formation. Sodium sulfite is added to keep the reactor in a reductive state and to prevent the oxidation of product L-DOPA. The L-DOPA is not soluble in the reaction medium, so it forms a crystalline precipitate (reaching 110 g/l) during the reaction (Yamada and Kumagai 1975; Kumagai 1999a, b).

Induction and repression mechanisms of TPL in *E. herbicola* were studied. It was found that TPL biosynthesis is regulated at the transcriptional level. Tyrosine phenol-lyase mRNA was increased by the addition of tyrosine and decreased by the addition of glucose in the medium. TyrR box and operator-like regions were found in the 5' flanking region of its gene, *tpl*. TyrR

box is a typical binding site on DNA where a regulator protein TyrR binds and controls transcription of the regulon of enzyme genes or transporter genes responsible for biosynthesis of aromatic amino acids or transport through cell membrane (Suzuki et al. 1995; Katayama et al. 1999). Katayama et al. reported three point mutations in the *tyrR* gene that caused high-level expression of *lacZ* in *E. coli* and *tpl* in *E. herbicola* (Katayama et al. 2000). The functions of the product of *tutB* gene and the gene itself, located just downstream of *tpl* in *E. herbicola*, were analyzed. It was elucidated that *tutB* encodes a tyrosine-specific transporter and this is essential for maximum induction of TPL in *E. herbicola* cells (Katayama et al. 2002).

L-Glutamic Acid

World production of monosodium L-glutamate using so-called coryneform bacteria is around 1 million tons per annum. Monosodium glutamate is used as a flavor enhancer and an intermediate material for chemical synthesis of medicines. Its ester is used as a detergent and the polymer as artificial skin. Two Japanese companies, Ajinomoto and Kyowa Hakko Kogyo, built factories and produced it in other countries, mainly in Southeast Asia. China, Korea, and Taiwan also are producing large amounts of monosodium L-glutamate.

Glutamic acid is produced by *Corynebacterium glutamicum* in the presence of high concentrations of sugar and ammonium, appropriate concentrations of minerals, and a limited concentration of biotin under aerobic conditions (Kikuchi and Nakao 1986). In 2–3 days, around 100 g of L-glutamate per liter accumulates in the medium.

Various glutamic acid-producing strains were reported after the first report on *Corynebacterium glutamicum*. They are *Brevibacterium flavum*, *Brevibacterium lactofermentum*, *Brevibacterium thiogenitalis*, and *Microbacterium ammoniaphilum*, and all strains are Gram-positive, nonsporulating, nonmotile, or rodlike cocci and all require biotin for growth. Currently, these strains are thought to belong to the genus *Corynebacterium*.

The carbon source most commonly used as a starting material is glucose, which is obtained by enzymatic hydrolysis of starch from corn, potato, and cassava. Waste molasses is also used since it is cheap. Acetic acid and ethanol are also good carbon sources to produce glutamate. A high concentration of a nitrogen source is necessary to accumulate glutamate, and ammonia gas, its solution, the inorganic salt, or urea is used in actual production.

Coryneform bacteria generally show high rates of sugar assimilation and highly active glutamate dehydrogenase, which is responsible for glutamate biosynthesis. Glucose incorporated in the cell is metabolized through the Embden-Meyerhof pathway (EMP) and a part of the tricarboxylic acid (TCA) cycle, and 2-oxoglutarate formed in the cycle is aminated to glutamate by the action of glutamate dehydrogenase.

Biotin is an important factor regulating the growth of the bacterium and glutamic acid production. Its suboptimal addition is essential to produce a large amount of glutamic acid in the medium (Clement and Lanneelle 1986). To use a starting material such as waste molasses, which contains excess biotin, the addition of penicillin to the medium during growth was found to be effective. In the production of glutamic acid, several saturated fatty acids or their esters were also found to function similarly to penicillin. A glycerol-requiring mutant of *Corynebacterium alkanolyticum* was used to produce glutamic acid in appreciable amounts without the addition of penicillin and without the need to control biotin concentration (Kikuchi and Nakao 1986).

Since these treatments are essential for the glutamate fermentation, it has been suggested that the cell surface of the bacteria is damaged under such conditions, and consequently leaking of glutamate takes place. This leaking theory has been accepted for a long time. But recently another published theory of excretion of glutamate suggested an exporter protein of glutamate was present on the cell surface of the bacterium (Kraemer 1994).

The amount of 2-oxoglutarate dehydrogenase complex (ODHC), which catalyzes the conversion of 2-oxoglutarate to succinyl-CoA as the first step of succinate synthesis in the TCA cycle, was reported to be decreased in glutamate-producing bacterial cells. And recently, the enzyme activity was confirmed to be very low in the presence of detergent, or limited amounts of biotin or penicillin (Kawahara et al. 1997). These results suggest that one of the main causes for the glutamate overproduction is the decrease of 2-oxoglutarate dehydrogenase activity (ODH). A disrupted (ODH) gene-bearing bacterial strain produced as much glutamate as the wild-type strain under conditions of glutamate overproduction.

Furthermore, a novel gene *dtsR* was cloned, which rescues the detergent sensitivity of a mutant derived from a glutamate-producing bacterium, *Corynebacterium glutamicum*

(Kimura et al. 1996). The authors found that this gene encodes a putative component of a biotin-containing enzyme complex and has something to do with fatty acid metabolism. The disruption of this gene causes constitutive production of glutamate even in the presence of excess biotin. The authors suggested that the overproduction of glutamate is caused by an imbalance of the coupling between fatty acid and glutamate synthesis (Kimura et al. 1997). They successfully showed that inducers of glutamate overproduction such as Tween 40 and limited amounts of biotin reduced the level of DtsR, which then triggered overproduction by decreasing the activity of ODHC (Kimura et al. 1999).

Kyowa Hakko Kogyo Co. Ltd., the Research Institute for Innovative Technology for Earth in Japan, and Degussa in Germany completed the analysis of the genomic DNA nucleotide sequence of *Corynebacterium glutamicum*.

D-p-Hydroxyphenylglycine

Kaneka Co. Ltd. started the enzymatic production of D-p-hydroxyphenylglycine (D-HPG) in 1980 in Singapore, and the immobilized D-carbamoylase reactor was introduced in this process in 1995. The annual production of D-HPG by this method is around 2,000 t. D-HPG is a starting material for the production of semisynthetic penicillins and cephalosporins, such as amoxicillin and cefadroxil. D-HPG is produced from DL-p-hydroxyphenylhydantoin (DL-HPH) by a two-step enzymatic method (Takahashi 1986).

The starting material DL-HPH is synthesized by the amidoalkylation of phenol (Ohhashi et al. 1981). Only D-HPH is hydrolyzed by hydantoinase to form D-HPG via N-carbamoyl-D-p-HPG. L-HPH is spontaneously racemized at a slightly alkaline pH. Then, during the reaction, only D-HPH is hydrolyzed to form D-HPG via N-carbamoyl-D-p-HPG. Finally, DL-HPH in the reaction mixture is completely hydrolyzed to D-HPG (● Fig. 4.6).

D-Hydantoin hydrolase activity was found in some bacteria belonging to the genera *Bacillus*, *Pseudomonas*, *Aerobacter*, *Agrobacterium*, and *Corynebacterium* and in actinomycetes belonging to the genera *Streptomyces* and *Actinoplanes*. D-Carbamylase activity was found in various bacteria belonging

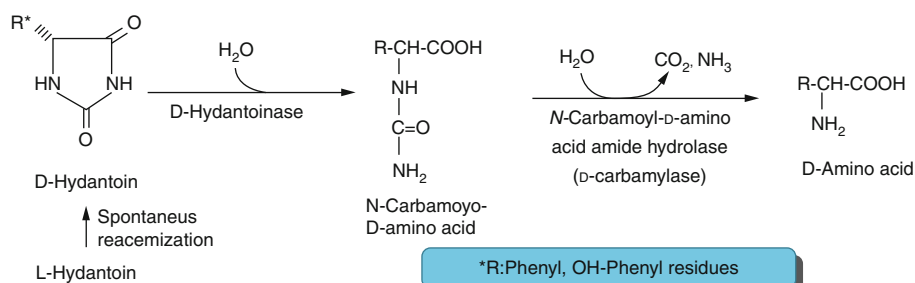

■ Fig. 4.6
Enzymatic synthesis of D-hydroxy-phenylglycine

to the genera *Agrobacterium*, *Pseudomonas*, *Comamonas*, and *Blastobacter*. The genes of these two enzymes were cloned, and an *E. coli* strain transformed by this gene was used as the practical enzyme source. To obtain stable D-carbamoylase for repeated use, a random mutation technique was applied to the *Agrobacterium* D-carbamoylase. Three heat stable mutant enzymes were obtained. These mutations were found at His 57, Pro203, and Val236. These mutations were combined in one molecule, and the mutant enzyme containing the triple mutation His57Tyr, Pro203Glu, and Val236Ala had 19 °C higher heat stability than did the wild-type enzyme (Ikenaka et al. 1999). *Escherichia coli* cells containing this mutant enzyme were immobilized and used for practical industrial production of D-HPG with the simultaneous use of immobilized D-hydantoinase on line. This immobilized mutant D-carbamoylase reactor can be used for 1 year without any supply of new enzyme.

D-Phenylglycine is also produced by the same enzymatic method using the corresponding starting material.

Hydroxy-L-proline

The industrial production of *trans*-4-hydroxy-L-proline was started by Kyowa Hakko Kogyo Co. Ltd. in 1997. 4-Hydroxy-L-proline is useful as a chiral starting material in chemical synthesis and as a starting material of medicinals, cosmetics, and food additives. *trans*-4-Hydroxy-L-proline is a component of animal tissue protein such as collagen and was extracted from collagen after hydrolysis with strong acid before this enzyme process was industrially utilized. The discovery of L-proline hydroxylases made the microbial production of hydroxyproline possible. *trans*-4-Hydroxy-L-proline or *cis*-3-hydroxy-L-proline is produced from L-proline by the respective action of L-proline 4-hydroxylase or 3-hydroxylase. The other substrate 2-oxoglutarate is supplied from glucose added to the reaction mixture through the EMP pathway and TCA cycle (► Fig. 4.7).

Ozaki et al. developed a specific hydroxyproline detection method with high-performance liquid chromatography (Ozaki et al. 1995) and screened strains for microbial proline hydroxylase activity. L-Proline 4-hydroxylase was found in some etamycin-producing actinomycetes belonging to the genera *Streptomyces*, *Dactylosporangium*, or *Amycolatopsis* (Shibasaki et al. 1999). L-Proline 3-hydroxylase was found in some telomycin-producing actinomycetes belonging to the genus *Streptomyces* and in bacteria belonging to *Bacillus* (Mori et al. 1996).

The genes of these proline hydroxylase-producing organisms were cloned in *E. coli* cells, respectively, and the cells overexpressing the enzyme were used as the enzyme source in the industrial process of L-hydroxyproline production. Since the genes obtained from actinomycetes had some difficulty in being highly expressed in *E. coli* cells, the genetic codons corresponding to the N-terminal of the enzyme protein were changed to match the codon usage in *E. coli*. Furthermore, the promoter of *trp* operon was introduced twice at the promoter site of the gene in the plasmid to achieve the overexpression. These transformants expressed 1,400 times higher activity of proline 4-hydroxylase and 1,000 times higher activity of proline 3-hydroxylase in comparison with the original strain.

2-Oxoglutarate, one of the substrates of hydroxylation, is made from glucose in the reaction medium via the EMP pathway and TCA cycle in *E. coli*, and the product succinate is recycled. The mutant strain of *E. coli* lacking the L-proline-degrading enzyme was obtained and used for the host cells in the production of L-hydroxyproline.

Using *E. coli* as the host cells in L-proline production, the direct production of L-hydroxyproline from glucose became possible. In this case, the derepressed genes of the L-proline biosynthetic pathway were introduced into *E. coli* cells together with the gene of L-proline hydroxylase.

L-Lysine

The estimated annual world production of L-lysine is around 500,000 t, almost all supplied by Ajinomoto, Kyowa Hakko Kogyo, Archer Daniels Midland (ADM), and Badische Anilin- und Soda-Fabrik (BASF). L-Lysine (an essential amino acid for swine and poultry) is useful as an additive to feeds such as grains and defatted soybeans, which contain less lysine.

L-Lysine is produced by some mutants derived from wild strains of glutamate-producing bacteria including *Corynebacterium glutamicum*, *Brevibacterium lactofermentum*, and *B. flavum* in the presence of high concentration of sugar and ammonium, at neutral pH, and under aerobic conditions (Tosaka and Takinami 1986).

The pathway of biosynthesis of L-lysine and L-threonine including controls of the biosynthesis in *Corynebacterium glutamicum* is shown in ► Fig. 4.8. The formation of phosphoaspartate from aspartate is the first step and is catalyzed by aspartokinase. The activity of this enzyme is controlled through concerted feedback inhibition by L-lysine and L-threonine.

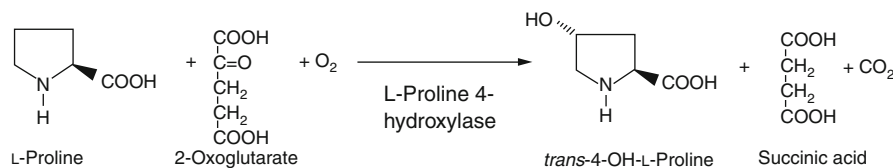

► Fig. 4.7
Enzymatic synthesis of L-hydroxyproline

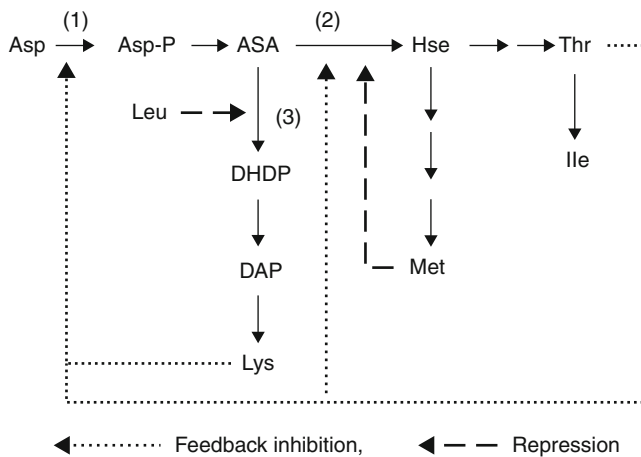

■ Fig. 4.8
 Regulation of lysine biosynthesis. ASA, aspartate- β -semialdehyde; DHP, dihydrodipicolinate; DAP, α , ϵ -diaminopimelate; and Hse, homoserine. (1) Aspartate kinase, (2) homoserine dehydrogenase, and (3) dihydrodipicolinate synthase

In 1958, Kinoshita and Nakayama of Kyowa Hakko Kogyo Co. Ltd. reported that the auxotrophic mutant of *Corynebacterium glutamicum*, which lacks homoserine dehydrogenase and is defective in L-homoserine (or L-threonine plus L-methionine) biosynthesis, produced L-lysine in the culture medium (Kinoshita et al. 1958). This was the first report on production of an amino acid by an auxotrophic mutant. Subsequently, amino acid production by auxotrophic mutants expanded greatly. Then, the mutants with the L-threonine- or L-methionine-sensitive phenotype due to the mutation in homoserine dehydrogenase (low activity) were also found to produce appreciable amounts of L-lysine in the culture medium (Tosaka and Takinami 1986). Furthermore, a lysine analogue (*S*-aminoethylcysteine)-resistant mutant was obtained as an L-lysine producer. In this strain, aspartokinase was insensitive to feedback inhibition (Tosaka and Takinami 1986). This is the first demonstration of amino acid production by an analogue-resistant mutant.

These characteristics of lysine production were combined to make strains that were much more efficient producers. In addition, the introduction of a leucine-requiring mutation also increases the amount of lysine, since in the mutant dihydrodipicolinate synthase is released from repression by leucine.

The precursors of lysine synthesis include phosphoenolpyruvate, pyruvate, and acetyl CoA. Many mutations are induced in lysine producer cells to supply sufficient amounts of these precursors in good balance. These are deletion mutants of pyruvate kinase, those that show low activity of pyruvate dehydrogenase, etc. Furthermore, an alanine requirement was also reported to be effective in increasing the lysine amount.

The genes of the enzymes responsible for the biosynthesis of lysine in *Corynebacterium* have been cloned, and their nucleotide sequences are known. These genes include aspartokinase, aspartate semialdehyde dehydrogenase, dihydrodipicolinate

synthase, dihydrodipicolinate reductase, tetrahydrodipicolinate succinylase, succinyl diaminopimelate desuccinylase, diaminopimelate dehydrogenase, and diaminopimelate decarboxylase (Tosaka and Takinami 1986). A host-vector system of *Corynebacterium* was established, and the introduction of some genes that encode the enzymes responsible for lysine biosynthesis (i.e., aspartokinase and dihydrodipicolinate synthase) was found to be effective in increasing the amount of lysine produced (Cremer et al. 1991).

A new gene *ldc* which encodes lysine decarboxylase (formerly known as *cadA* in *E. coli*) has been identified, and the enzyme was purified from the overexpressing strain. The lysine decarboxylase encoded by *ldc* is constitutively produced by *E. coli* cells, although lysine decarboxylase encoded by *cadA* is inducible (Kikuchi et al. 1997). It is interesting to note that this new lysine decarboxylase is present in lysine-producing *Corynebacterium* and to investigate the effects of deleting the gene on L-lysine production.

Vrljic et al. (1996) cloned a new gene *lysE* from *Corynebacterium glutamicum* and showed that it encodes a specific L-lysine exporter. Recently, they analyzed the membrane topology of the gene product and showed that it is a member of a protein family found in some other bacteria such as *E. coli*, *Bacillus subtilis*, *Mycobacterium tuberculosis*, and *Helicobacter pylori*. The authors suggested that LtsE superfamily members would be shown to catalyze export of a variety of biologically important solutes including amino acids (Aleshin et al. 1999; Vrljic et al. 1999; Zakataeva et al. 1999).

L-Threonine

The annual worldwide production of L-threonine is around 13,000 to 14,000 t. L-Threonine is an essential amino acid for humans and some livestock animals, such as pigs and poultry. It is used as an additive for animal feed, medicines, food, and cosmetics.

L-Threonine is produced by some auxotrophic mutants or threonine-analogue-resistant mutants, and those are created by genetic engineering techniques. The bacteria used are *Escherichia coli*, *Corynebacterium glutamicum*, *Brevibacterium lactofermentum*, *B. flavum*, *Serratia marcescens*, and *Proteus rettgeri* (Nakamori 1986). L-Threonine production by fermentation was started in the 1970s. The auxotrophic mutant and analogue-resistant mutant strains obtained for this purpose were cultured in the presence of amino acids required by the mutant.

Auxotrophic mutants of L-lysine, diaminopimelate, or L-methionine were found to produce L-threonine in the culture medium, but the amount was not high enough to justify their use in practical production. A resistant mutant to an L-threonine analogue, α -amino- β -hydroxyvaleric acid (AHV), was obtained and shown to be an L-threonine producer. In this strain, homoserine dehydrogenase was insensitive to the feedback inhibition by L-threonine (► Fig. 4.8). The much stronger L-threonine-producing strains were obtained by the combination of the auxotrophic mutations and AHV-resistant mutation.

L-Threonine-producing mutant of *S. marcescens* was induced by the techniques of phage transduction. The strain has the following properties: deficiency of L-threonine-degrading enzymes; a mutation in the aspartokinase and homoserine dehydrogenase genes, making them insensitive to feedback inhibition by L-threonine; mutations in genes for L-threonine biosynthetic enzymes, releasing them from repression by L-threonine; a mutation in the aspartokinase gene, making it insensitive to feedback inhibition by L-lysine; and a mutation in the aspartokinase and homoserine dehydrogenase genes, releasing them from the repression by L-methionine.

Recombinant DNA techniques were employed to improve the L-threonine producer. Genes of the threonine operon obtained from AHV-resistant and feedback-insensitive mutants were introduced into a threonine-deficient mutant of *E. coli* to amplify the expression of enzymes and to increase the amount of L-threonine. *Escherichia coli* mutant strains were also constructed with amplified genes of the threonine operon (obtained from AHV-resistant and feedback-insensitive mutants) by the action of Mu phage on the chromosomal DNA. This strain is used in France for L-threonine production. Okamoto et al. constructed an L-threonine hyper-producing *E. coli* mutant that can produce L-threonine (100 g/l) in 77 h. They suggested that uptake of L-threonine in this strain is impaired (Okamoto et al. 1997).

References

- Aleshin VV, Zakataeva NP, Livshits VA (1999) A new family of amino-acid-efflux proteins. *Trends Biochem Sci* 24:133–135
- Chibata I, Kakimoto T, Kato J (1965) Enzymatic production of L-alanine by *Pseudomonas dachnae*. *Appl Microbiol* 13:638–645
- Chibata I, Tosa T, Kakimoto T (1986a) Alanine. In: Aida K, Chibata I, Nakayama K, Takinami K, Yamada H (eds) *Biotechnology of amino acid production*. Kodansha/Elsevier, Tokyo/Amsterdam, pp 224–232
- Chibata I, Tosa T, Sato T (1986b) Aspartic acid. In: Aida K, Chibata I, Nakayama K, Takinami K, Yamada H (eds) *Biotechnology of amino acid production*. Kodansha/Elsevier, Tokyo/Amsterdam, pp 144–151
- Clement Y, Lanneelle G (1986) Glutamate excretion mechanism in *Corynebacterium glutamicum*: triggering by biotin starvation or by surfactant addition. *J Gen Microbiol* 132:925–929
- Cremer J, Eggeling L, Sahn H (1991) Control of the lysine biosynthesis sequence in *Corynebacterium glutamicum*, as analyzed by overexpression of the individual corresponding genes. *Appl Environ Microbiol* 57:1746–1752
- Fusee MC, Swann WE, Carlson GJ (1981) Immobilization of *Escherichia coli* cells containing aspartase activity with polyurethane and its application for L-aspartic acid production. *Appl Environ Microbiol* 42:672–676
- Hashimoto S, Katsumata R (1999) Mechanism of alanine hyperproduction by *Arthrobacter oxydans* HAP-1: metabolic shift to fermentation under nongrowth aerobic conditions. *Appl Environ Microbiol* 65:2781–2783
- Ikenaka Y, Nanba H, Yajima K, Yamada Y, Takano M, Takahashi S (1999) Thermostability reinforcement through a combination of thermostability-related mutations of N-carbamyl-D-amino acid amidohydrolase. *Biosci Biotechnol Biochem* 63:91–95
- Katayama T, Suzuki H, Yamamoto K, Kumagai H (1999) Transcriptional regulation of tyrosine phenol-lyase gene mediated through TyrR and cAMP receptor protein. *Biosci Biotechnol Biochem* 63:1823–1827
- Katayama T, Suzuki H, Koyanagi T, Kumagai H (2000) Cloning and random mutagenesis of the *Erwinia herbicola* tyrR gene for high-level expression of tyrosine phenol-lyase. *Appl Environ Microbiol* 66:4764–4771
- Katayama T, Suzuki H, Koyanagi T, Kumagai H (2002) Functional analysis of the *Erwinia herbicola* tutB gene and its product. *J Bacteriol* 184:3135–3141
- Kawahara Y, Takahashi-Fuke K, Shimizu E, Nakamatsu T, Nakamori S (1997) Relationship between the glutamate production and the activity of 2-oxoglutarate dehydrogenase in *Brevibacterium lactofermentum*. *Biosci Biotechnol Biochem* 61:109–1112
- Kikuchi M, Nakao Y (1986) Glutamic acid. In: Aida K, Chibata I, Nakayama K, Takinami K, Yamada H (eds) *Biotechnology of amino acid production*. Kodansha/Elsevier, Tokyo/Amsterdam, pp 101–120
- Kikuchi YH, Kojima T, Takatsuka Y, Tanaka T, Kamio Y (1997) Characterization of a second lysine decarboxylase isolated from *Escherichia coli*. *J Bacteriol* 179:4486–4492
- Kimura E, Abe C, Kawahara Y, Nakamatsu T (1996) Molecular cloning of a novel gene, dtsR, which rescues the detergent sensitivity of a mutant derived from *Brevibacterium lactofermentum*. *Biosci Biotechnol Biochem* 60:1565–1570
- Kimura E, Abe C, Kawahara Y, Nakamatsu T, Tokuda H (1997) A dtsR gene-disrupted mutant of *Brevibacterium* requires fatty acids for growth and efficiently produces L-glutamate in the presence of an excess biotin. *Biochem Biophys Res Commun* 234:157–161
- Kimura E, Yagoshi C, Kawahara Y, Ohsumi T, Nakamatsu T, Tokuda H (1999) Glutamate overproduction in *Corynebacterium glutamicum* triggered by a decrease in the level of a complex comprising dtsR and a biotin-containing subunit. *Biosci Biotechnol Biochem* 63:1274–1278
- Kinoshita S, Nakayama K, Kitada S (1958) L-Lysine production using microbial auxotroph. *J Gen Appl Microbiol* 4:128–129
- Kraemer R (1994) Secretion of amino acids by bacteria: physiology and mechanism. *FEMS Microbiol Rev* 13:75–79
- Kumagai H (1999a) Dihydroxyphenylalanine, produced by microorganisms. In: Flicinger MC, Drew SW (eds) *Encyclopedia of bioprocess, technology: fermentation, biocatalysis and bioseparation*. Wiley, New York, pp 821–823
- Kumagai H (1999b) Tyrosine phenol-lyase. In: Flicinger MC, Drew SW (eds) *Encyclopedia of bioprocess, technology: fermentation, biocatalysis and bioseparation*. Wiley, New York, pp 2605–2609
- Mori H, Shibasaki T, Uozaki Y, Ochiai K, Ozaki A (1996) Detection of novel proline 3-hydroxylase activities in *Streptomyces* and *Bacillus* spp. by region- and stereospecific hydroxylation of L-proline. *Appl Environ Microbiol* 62:1903–1907
- Nakamori S (1986) Threonine and homoserine. In: Aida K, Chibata I, Nakayama K, Takinami K, Yamada H (eds) *Biotechnology of amino acid production*. Kodansha/Elsevier, Tokyo/Amsterdam, pp 173–182
- Ohhashi T, Takahashi S, Nagamachi T, Yoneda K, Yamada H (1981) A new method for 5-(4-hydroxyphenyl)hydantoin synthesis. *Agric Biol Chem* 45:831–838
- Okamoto K, Kino K, Ikeda M (1997) Hyperproduction of L-threonine by an *Escherichia coli* mutant with impaired L-threonine uptake. *Biosci Biotechnol Biochem* 61:1877–1882
- Ozaki A, Shibasaki T, Mori H (1995) Specific proline and hydroxyproline detection method by post-column derivatization for high-performance liquid chromatography. *Biosci Biotechnol Biochem* 59:1764–1765
- Sano K, Mitsugi K (1978) Enzymatic production of L-cysteine from DL-2-amino- Δ^2 -thiazoline-4-carboxylic acid by *Pseudomonas thiazolinohilum*: optimal conditions for the enzyme formation and enzymatic reaction. *Agric Biol Chem* 42:2315–2321
- Sano K, Yokozeki K, Tamura F, Yasuda N, Noda I, Mitsugi K (1977) Microbial conversion of DL-2-amino- Δ^2 -thiazoline-4-carboxylic acid to L-cysteine and L-cysteine: screening of microorganisms and identification of products. *Appl Environ Microbiol* 34:806–810
- Sano K, Eguchi NY, Mitsugi K (1979) Metabolic pathway of L-cysteine formation from DL-2-amino- Δ^2 -thiazoline-4-carboxylic acid by *Pseudomonas*. *Agric Biol Chem* 43:2373–2374
- Shibasaki T, Mori H, Chiba S, Ozaki A (1999) Microbial proline 4-hydroxylase screening and gene cloning. *Appl Environ Microbiol* 65:4028–4031
- Suzuki H, Katayama T, Yamamoto K, Kumagai H (1995) Transcriptional regulation of tyrosine phenol-lyase gene of *Erwinia herbicola* AJ2985. *Biosci Biotechnol Biochem* 59:2028–2032

- Takahashi S (1986) Microbial production of D-p-hydroxyphenylglycine. In: Aida K, Chibata I, Nakayama K, Takinami K, Yamada H (eds) Biotechnology of amino acid production. Kodansha/Elsevier, Tokyo/Amsterdam, pp 269–279
- Takamatsu S, Umemura I, Yamamoto K, Sato T, Chibata I (1982) Production of L-alanine from ammonium fumarate using two immobilized microorganisms. *Eur J Appl Microbiol Biotechnol* 15:147–152
- Terasawa M, Yukawa H, Takayama Y (1985) Production of L-aspartic acid from *Brevibacterium* by the cell re-using process. *Process Biochem* 20:124–128
- Tosa T, Sato T, Mori T, Matsuo Y, Chibata I (1973) Continuous production of L-aspartic acid by immobilized aspartase. *Biotechnol Bioeng* 15:69–84
- Tosaka O, Takinami K (1986) Lysine. In: Aida K, Chibata I, Nakayama K, Takinami K, Yamada H (eds) Biotechnology of amino acid production. Kodansha/Elsevier, Tokyo/Amsterdam, pp 152–172
- Vrljic M, Sahn H, Eggeling L (1996) A new type of transporter with a new type of cellular function: L-lysine export from *Corynebacterium glutamicum*. *Mol Microbiol* 22:815–826
- Vrljic M, Garg J, Bellmann A, Wachi S, Freudl R, Malecki MJ, Sahn H, Kozina VJ, Eggeling L, Saier MH Jr (1999) The LysE superfamily: topology of the lysine exporter LysE of *Corynebacterium glutamicum*, a paradigm for a novel superfamily of transmembrane solute translocators. *J Mol Microbiol Biotechnol* 1:327–336
- Yamada H, Kumagai H (1975) Synthesis of L-tyrosine related amino acids by β -tyrosinase. In: Perlman D (ed) *Advances in applied microbiology*, vol 19. Academic, New York, pp 249–288
- Yokozeiki K, Eguchi C, Kamimura A, Kubota K (1988) Asymmetric synthesis of S-carboxymethyl-L-cysteine by a chemico-enzymatic method. *Agric Biol Chem* 52:2367–2368
- Yukawa H (1999) L-aspartic acid. In: Flicinger MC, Drew SW (eds) *Encyclopedia of bioprocess technology: fermentation, biocatalysis and bioseparation*. Wiley, New York, pp 206–208
- Zakataeva NP, Aleshin VV, Tokmakova IL, Troshin PV, Livshits VA (1999) The novel transmembrane *Escherichia coli* proteins involved in the amino acid efflux. *FEBS Lett* 452:228–232
- Zupansic T, Kittle J, Baker B, Miller C, Palmaer D, Asai Y, Inui M, Verrttes A, Kobayashi M, Kurusu M, Yukawa H (1995) Isolation of promoters from *Brevibacterium flavum* strain MJ233C and comparison of their gene expression levels in *B. flavum* and *Escherichia coli*. *FEMS Microbiol Lett* 131:121–125

5 Microbial Exopolysaccharides

Avinash Mishra · Bhavanath Jha

Discipline of Marine Biotechnology and Ecology, CSIR-Central Salt and Marine Chemicals Research Institute (CSIR-CSMCRI), Bhavnagar, Gujarat, India

Introduction	179
Sources of Exopolymers Producing Bacteria	180
Biosynthesis and Genetic Regulation	181
EPS Composition and Analytical Techniques/Characterization	182
Common Exopolysaccharides: Property and Applications	187
Future Prospects	189

Abstract

Microbial polysaccharides are produced in two forms, capsular polysaccharide (CPS) and exopolysaccharide (EPS). EPSs of microbial origin are ubiquitous in nature, have unique properties, and can be isolated from the bacteria in fresh water, marine environment, extreme conditions, and soil ecosystem. Exopolysaccharides are comprised of repeated units of sugar moieties, attached to a carrier lipid, and can be associated with proteins, lipids, organic and inorganic compounds, metal ions, and DNA. Specific functions and precise role of EPSs depend on structural units and ecological niches of the host microorganisms. EPSs produced by bacteria have great potential, and physicochemical characteristics of EPS decide its possible commercial application ranging from pharmaceutical to food-processing, extended to detoxification, bioremediation, paints, biotechnology, and petrochemicals. Exploitation of microbial exopolysaccharides is relatively unexplored and research interest is constantly increasing toward isolation, characterization, and applications of novel exopolysaccharides as renewable resources. Downstream processing and genetic engineering for enhanced biosynthesis of EPS require further emphasis.

Introduction

Extracellular polymeric substances are metabolic products. Their production by selected microorganisms was first reported in the 1880s (Whitfield 1988). Extracellular polysaccharides (EPSs) accumulate on the microbial cell surface and provide protection to the cells by stabilizing membrane structure against the harsh external environment. EPSs also serve as carbon and energy reserves. EPSs are a heterogeneous matrix of polymers

comprised of polysaccharides, proteins, nucleic acids, and (phospho) lipids (McSwain et al. 2005). Generally, EPSs have often been reported in bacteria and cyanobacteria (De Philippis et al. 2001; Parikh and Madamwar 2006; Chi et al. 2007); however, they have also been reported in the marine microalga *Chroomonas* sp. (Bermúdez et al. 2004), *Dunaliella salina* (Mishra and Jha 2009), the medicinal mushroom *Phellinus linteus* (Zou et al. 2006), yeast (Duan et al. 2008), basidiomycetes (Manzoni and Rollini 2001; Chi and Zhao 2003), and marine microorganisms (Satpute et al. 2010). EPS-producing microorganisms have been isolated from different natural sources of both aquatic and terrestrial environments, like freshwater, marine water, wastewater, soils, biofilms, and also extreme niches such as hot springs, cold environments, hypersaline and halophilic environments, salt lakes, and salterns (Maugeri et al. 2002; Nichols et al. 2005; Mata et al. 2006; Gerbersdorf et al. 2009; Satpute et al. 2010; Andersson et al. 2011; Kavita et al. 2011).

Microbial polysaccharides show biotechnological promise in pharmaceutical industries as immunomodulators and healing agents and in food-processing industries as gelling and thickening agents. Some EPSs are used as biosurfactants in detoxification of petrochemical oil-polluted areas. Some microbial exopolymers that are commonly used in industries are summarized in Table 5.1. Exopolymers are used as thickeners and gelling agents to improve food quality and texture in food industries. They can be used as adjuvants to enhance nonspecific immunity, as hydrophilic matrix for development of bacterial vaccines and controlled release of drugs in pharmaceutical industry. Besides these, different environmental applications are also proposed as improvement of water-holding capacity of soil, detoxification of heavy metals and radionuclide-contaminated water, and removal of solid matter from water reservoirs for cyanobacterial EPSs (Bender and Phillips 2004). Some special applications like sludge settling and dewatering were demonstrated with EPSs (Subramanian et al. 2010). Bioremediation is one of most common application for EPSs as they have the capacity to adsorb oil and make it more easily biodegraded. Heavy metals and organic contaminants can be efficiently removed by EPSs as they have a large number of negatively charged functional groups (Liu et al. 2001; Sheng et al. 2005; Bhaskar and Bhosle 2006; Zhang et al. 2006) which form multiple complexes with heavy metal ions.

Methods of EPSs extraction are very important as their physicochemical properties may get affected during isolation and purification. Several physical and chemical methods are available for the extraction of EPSs from different sources,

■ **Table 5.1**

Microbial exopolymers and their applications (Sutherland 1998; Kumar et al. 2007; Vu et al. 2009)

Biopolymers	Possible applications
Acetan	Viscosifier and gelling agent
Alginate	Immobilization and microencapsulation
Cellulose	Temporary artificial skin, natural nondigestible fibers, hollow fibers or membranes, and acoustic membranes in audiovisual equipment
Curdlan	Gelling agent
Cyclosporans	Encapsulation of drugs and food component
Dextran	Blood plasma extender or blood flow improving agent, cholesterol lowering agent, and microcarrier in tissue/cell culture
Emulsan	Emulsification and immobilization
Gellan	Solidification/gelling agent
Hyaluronic acid	Moisturization and synovial fluid replica
Kefiran	Gelatination and viscoelasticity
Levan and Alternan	Similar as dextran
Succinoglycan	Gelling agent and immobilization
Welan	Stabilizer and viscosifier
Xanthan	Emulsification and gelatination

such as cell suspension, biofilm, sludge, solid surfaces, and waters. Physical methods include centrifugation, sonication, heating, freeze thawing, while in chemical methods, different chemical agents, like ethylenediamine tetraacetic acid (EDTA), NaOH, and formaldehyde, are used for extractions. Structural diversity and physicochemical characteristics of biopolymers are exhibited by different EPSs. Several analytical methods have been adopted for the analysis of exopolysaccharides, including HPLC, FTIR, and NMR. Monosaccharide composition is generally analyzed by HPLC or advances methods of GC-MS, while functional groups are investigated by FTIR and NMR. Recently, MALDI TOF TOF (Mishra et al. 2011), AFM (Pletikapić et al. 2011), XRD (Mishra et al. 2011), etc., have been used for qualitative analysis of exopolymers. This chapter aims to present comprehensive information on microbial exopolymers, methods of analysis, and their potential future applications.

Sources of Exopolymers Producing Bacteria

Microbial polysaccharides are classified as (a) cell wall polysaccharides, (b) intracellular polysaccharides, and (c) extracellular polysaccharides. The first two are integral part of the cell, while exopolysaccharides are produced by numerous microorganisms, many of which are isolated from aquatic, especially marine ecosystems. About 134 strains have been isolated from 18 different saline habitats, including inland salterns, marine salterns,

and soils, and a taxonomic study was reported by Martínez-Cánovas et al. (2004) in order to establish the relationship between exopolysaccharide-producing bacterial strains living in diverse hypersaline habitats. A halophilic, thermotolerant *Bacillus* strain B3-15 was isolated from water of a shallow, marine hot spring at Vulcano island (Eolian islands), Italy (Maugeri et al. 2002); similarly, Nicolaus et al. (2002) isolated a thermophilic bacteria from the genus *Geobacillus* from shallow, marine hydrothermal vents of flegrean areas (Italy) and an EPS-producing bacterium *Alteromonas macleodii* subsp. *fijiensis*; *Pseudoalteromonas* strain HYD 721 was isolated from a deep-sea hydrothermal vent (Raguénès et al. 1996; Rougeaux et al. 1999). Extreme marine habitats, deep-sea hydrothermal vents, volcanic and hydrothermal marine areas, and shallow submarine thermal springs were observed as a new source of EPS-producing bacteria (Poli et al. 2010). In contrast to thermal marine environments, little has been reported on EPS-producing bacteria from cold marine environments. Nichols et al. (2004) studied the EPS-producing bacterial strains CAM025 and CAM036, which were closely related to the genus *Pseudoalteromonas* and isolated from particulate material and melted sea ice, collected from the Southern Ocean. Similarly, a gamma-proteobacterium *Pseudoalteromonas* sp. SM9913 was isolated from sea sediment in the Bohai Gulf of the Yellow Sea of northeastern China (Qin et al. 2007). A flagella-containing EPS-producing, gamma-proteobacterium *Colwellia psychrerythraea* strain 34H was isolated from cold marine environments of Arctic and Antarctic sea ice (Marx et al. 2009).

Marine microorganisms are rich natural resource of exopolysaccharide producers, and several marine microorganisms were isolated from the sea for the EPS production (Satpute et al. 2010). A halophilic EPS-producing archaea *Haloferax mediterranei* was isolated from the Mediterranean Sea (Anton et al. 1988). A novel EPS-R-producing halophilic marine bacterium *Hahella chejuensis* was isolated from a marine sediment of Marado, Cheju Island, Republic of Korea (Lee et al. 2001), and a new halo-alkalophilic *Halomonas alkaliantarctica* strain CRSS was isolated from salt sediments near the salt lake in Cape Russell in Antarctica (Poli et al. 2007). Mata et al. (2008) studied three moderately halophilic, exopolysaccharide-producing bacteria belonging to the family Alteromonadaceae isolated from inland hypersaline habitats in Spain. Jiao et al. (2010) isolated an acidophile from natural microbial pellicle biofilms growing on acid mine drainage water and characterized their extracellular polymeric substances. Ortega-Morales et al. (2007) studied tropical intertidal biofilms that contained *Microbacterium* and *Bacillus* species as a source of novel exopolymers. Exopolysaccharides produced by Antarctic isolates, representing the genera *Pseudoalteromonas*, *Shewanella*, *Polaribacter*, and *Flavobacterium* were characterized by Nichols et al. (2005). They concluded that members of the Gammaproteobacteria and Cytophaga-Flexibacter-Bacteroides dominate polar sea ice and seawater microbial communities. Several marine thermophilic strains were isolated from shallow hydrothermal vents and marine hot springs, near Lucrino area (gulf of Pozzuoli,

Naples, Italy), and around Ischia Island (Flegrean areas, Italy) and analyzed for exopolysaccharide production (Nicolaus et al. 2004). They also identified four new polysaccharides from thermophilic marine bacteria *Bacillus thermantarcticus* isolated from the crater of Mount Melbourne. Ganesh-Kumar et al. (2004) screened some heavily polluted soil samples from the mudflats surrounding the city of Incheon, Korea, and isolated a haloalkalophilic bacterium *Bacillus* sp. I-450 that was identified as an extracellular polysaccharide producer. Most of the marine producers of EPSs are Gram-negative bacteria such as *Pseudomonas*, *Acinetobacter*, *Vibrio*, and *Alteromonas*. EPSs from marine biofouling *Vibrio* species, namely, *V. harveyi*, *V. alginolyticus*, *V. furnissii*, and *V. parahaemolyticus* (Muralidharan and Jayachandran 2003; Bramhachari and Dubey 2006; Bramhachari et al. 2007; Kavita et al. 2011) were characterized in detail.

Biosynthesis and Genetic Regulation

EPSs are synthesized intracellularly either throughout growth or during late logarithmic or stationary phase. Rate of EPS production also depends on stresses, namely, nutrient imbalance, salt, temperature, pH, etc. Microbial exopolysaccharides are apparently synthesized in four steps (Stanford 1979) with the help of four groups of enzymes (Kumar et al. 2007) as shown in ▶ Fig. 5.1. In the first step (uptake of substrate), a specific substrate, for example, glucose, is taken up by the bacterial cell. Entry of sugar moiety may be accomplished by active transport, diffusion, or group translocation (Roseman 1972). In the second step, metabolism of sugar proceeds, and the substrate is phosphorylated. The intracellular enzyme “hexokinase” phosphorylates glucose to glucose-6-phosphate which is subsequently converted to glucose-1-phosphate by

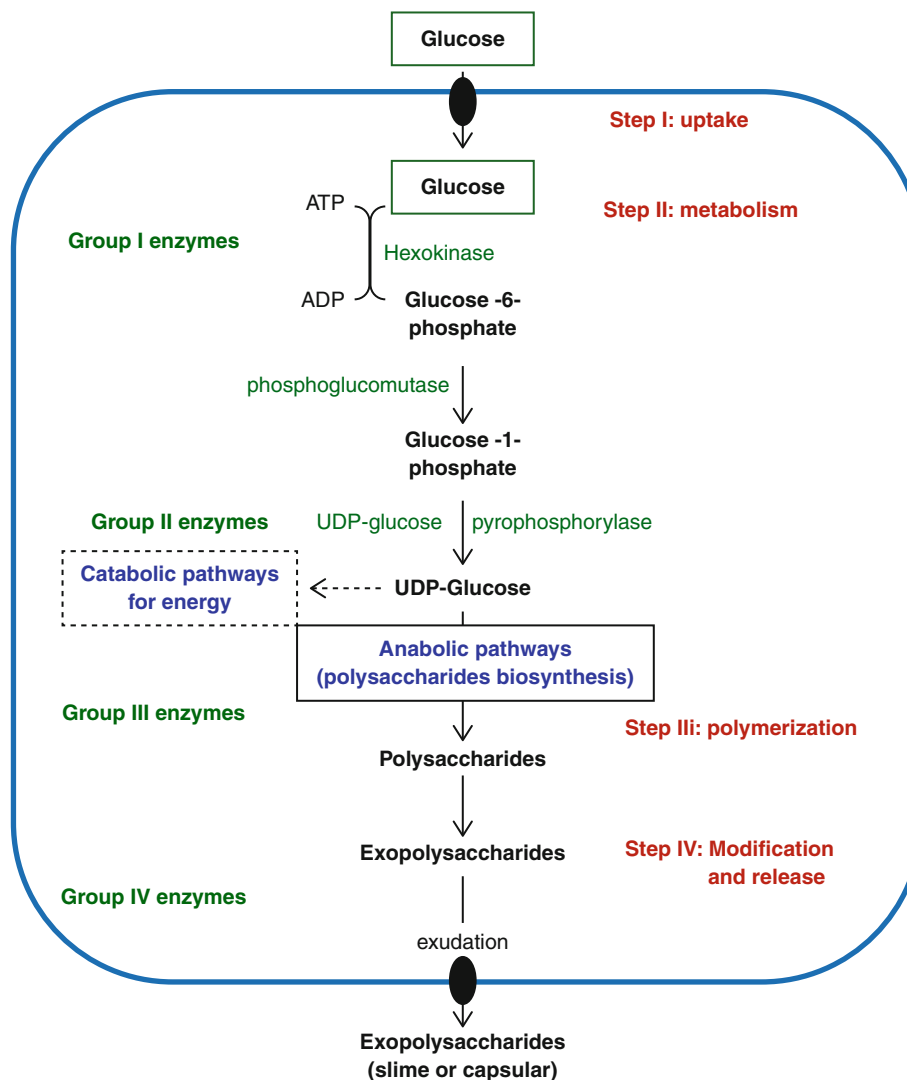

■ Fig. 5.1

Schematic representation of microbial exopolysaccharide biosynthesis

“phosphoglucomutase.” The phosphorylated glucose may be utilized for energy (i.e., catabolism) or for the formation of polysaccharides (anabolism). Enzyme of group II “UDP-glucose pyrophosphorylase” convert glucose-1-phosphate to UDP-glucose (uridine diphosphate glucose). UDP-glucose is a key intermediate, which can be interconverted to other sugars and proceed toward catabolic pathways. It can also enter in third step of polymerization, where polysaccharides are synthesized by an anabolic pathway. Thus, fate of intermediate and formation of polysaccharides is controlled by the cell, which can be achieved by genetic regulation of synthesis or hydrolysis of precursors (Lieberman and Markovitz 1970). Bacterial polysaccharides are comprised of repeating units of sugars moieties, which are synthesized by third group of enzymes “glycosyltransferases.” They transfer a sugar moiety to a repeating unit, which is attached to a glycosyl carrier lipid, identified as isoprenoid alcohol. The terminal alcohol group of lipid carrier is linked through a pyrophosphate bridge to a monosaccharide unit. Thus, in this step, monomers are polymerized, and polysaccharides are synthesized. Individual repeating sugar units are linked onto a lipid carrier through glycosyltransferases, a key enzyme that catalyzes the transfer of sugar moieties from activated donor molecules to specific acceptor molecules, forming a glycosidic bond (Campbell et al. 1997). Polysaccharides can be modified in fourth step by different enzymatic activities like acylation, acetylation, sulphation, and methylation. Modified polysaccharides are transported to the cell surface and finally exuded from the cell in the form of loose slime or a capsule (Margaritis and Pace 1985) with the help of group IV hydrophobic enzymes like flippase (Liu et al. 1996), permease (Daniels et al. 1998), or ABC transporters (Sutherland 2001).

Homology among the gene and gene products was noted for different polysaccharide-synthesizing systems, and a gene sequence of 12–17 kb (single or multiple copies) may be required (Sutherland 2001). Length and copy number of the responsible gene depends on the complexity of polysaccharide. Biosynthesis of alginate in *Pseudomonas aeruginosa* is under control of single operon includes *algA*, *algC*, *algD*, *algE*, and *algK* genes, while in *Azotobacter vinelandii*, it is regulated by three transcriptional units (Martinez-Salazar et al. 1996; Gacesa 1998). Regulatory systems comprise similar clusters of genes and gene products in both bacterial species.

Exopolysaccharide synthesis is generally controlled by gene (s) located on chromosomes, but in some bacteria, it is controlled through a two component system, that is, by megaplasmids and chromosome. In *E. coli* strains, generally one chromosomal segment controls synthesis of the sugar nucleotides required for polysaccharide formation along with enzymes for monosaccharide transfer and polymerase (Sutherland 2001). In contrast, biosynthesis of succinoglycan is regulated by a two component system (chromosomal and megaplasmid) comprised of about 30 genes (Cheng and Walker 1998) in *Rhizobium meliloti*, in which succinoglycan biosynthesis is fully characterized (Glucksman et al. 1993; Becker et al. 1995).

Biosynthesis of xanthan in *Xanthomonas campestris* is regulated by eight chromosomal gene loci, and gene loci *eps7*

contains the *gum* gene cluster, encoding functional enzymes required for assembly of the lipid-bound repeating unit (Tseng et al. 1999). Gum gene cluster is a linear sequence of 16 kb transcribed as a 12-cistron operon containing two promoters (Fig. 5.2a), one upstream to gene *gumB*, and a second internal upstream to gene *gumK* (Katzen et al. 1998). It was observed that genes *gumB*, *gumC*, and *gumJ* showed homology with *kpsD*, *exoP*, and *exoT*, respectively, and are involved in translocation or export of the polymer. Gene *gumD* product shows similarity to bacterial glucosyl- and galactosyl-1-phosphate transferases and thus is probably involved in the first step of xanthan biosynthesis, while genes *gumM*, *gumH*, *gumK*, and *gumI* encode glycosyltransferases II, III, IV, and V, respectively (Katzen et al. 1998). These gene products are involved in the transfer of a glycosyl residue to growing lipid-linked oligosaccharide. Genes *gumF* and *gumG* are involved in acetylation of mannose and encode acetyltransferase, while gene *gumL* encodes ketal pyruvate transferase and thus is involved in further modification (Katzen et al. 1998).

Similar to the gum gene cluster, a 29-kb multicistronic locus was detected in *Sphingomonas* sp. and contains regulatory genes required for the biosynthesis of Sphingan S-88 (Yamazaki et al. 1996). Gene *spsB* of *Sphingomonas* showed homology with *gumD* and encodes a priming glycosyltransferase. Like xanthan biosynthesis, several genes are involved in acetan synthesis in *Acetobacter xylinum*. Nucleotide sugar synthesis is regulated by genes *aceF* and *aceM*, and gene cluster *aceFA* and *aceBDCE* is involved in the repeating unit synthesis, polymerization, and export. Enzymatic glycosyltransferases activity is controlled by genes *aceA*, *aceB*, and *aceC* (Griffin et al. 1996a, b, 1997a, b). It was observed that initial steps of formation of repeating oligosaccharide unit are controlled by the same set of genes encoding glycosyltransferases in both acetan and xanthan biosynthesis, as both have a similar structure (Griffin et al. 1996a; Katzen et al. 1998).

Biosynthesis of exopolysaccharides in *Streptococcus thermophilus* Sfi6 is regulated by *eps* gene cluster (Fig. 5.2b) of 14.5-kb region comprised of 13 genes, namely, *epsA* to *epsM* (Stinglele et al. 1996). Gene *epsA* located at the beginning of the cluster is involved in the regulation of EPS expression, and the central region (*epsE*, *epsF*, *epsG*, *epsH*, and *epsI*) of the gene cluster is involved in biosynthesis of the tetramer repeating unit. Gene *epsE* encodes the galactosyltransferase, catalyzing the first step of biosynthesis of the repeating unit. Genes upstream (*epsC* and *epsD*) and downstream (*epsJ* and *epsK*) of the central region regulate polymerization and export of the EPS.

EPS Composition and Analytical Techniques/Characterization

EPSs are comprised of repeating units of monosaccharides, which may link with proteins (glycoproteins), lipids (glycolipids), acids (e.g., glucuronic acid, galacturonic acid, or mannuronic acid), and/or extracellular DNA. EPSs mostly

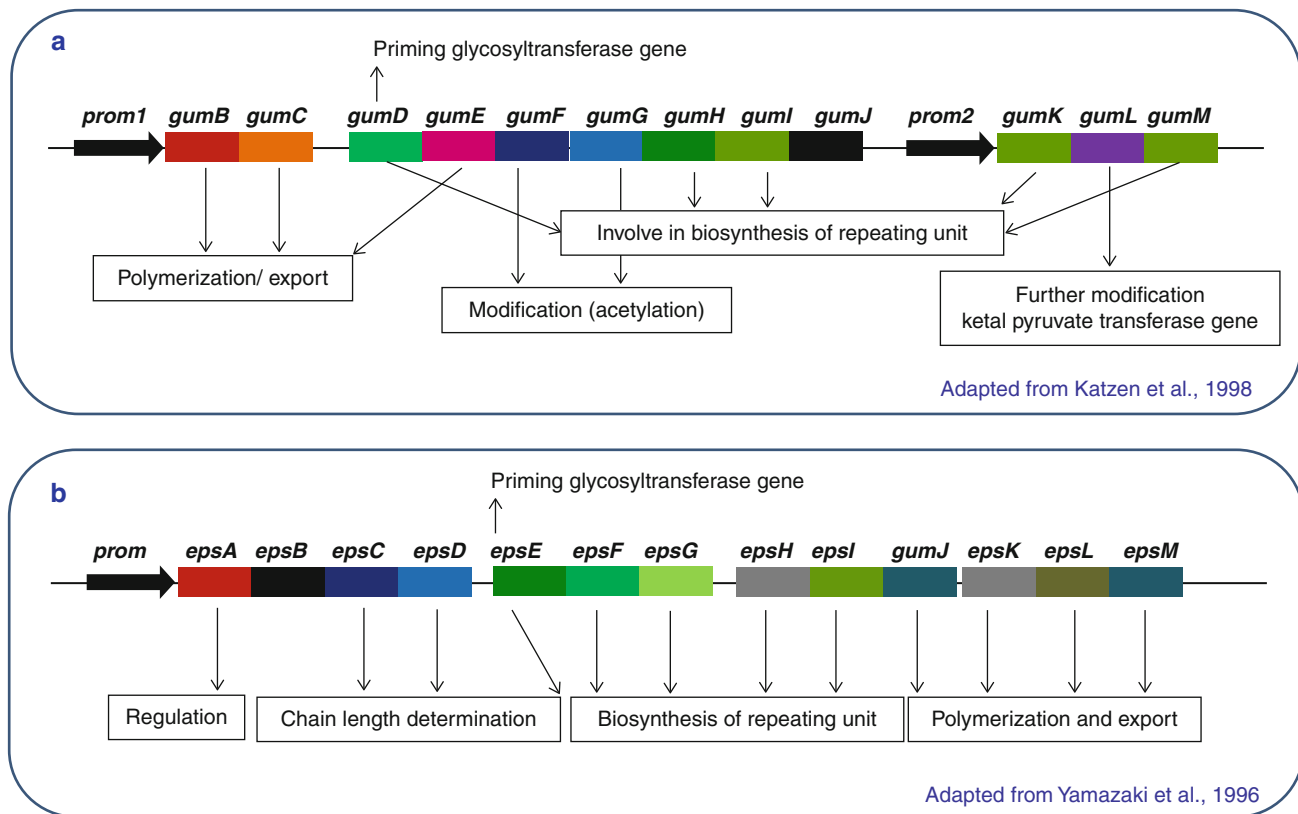

■ Fig. 5.2

Schematic representation of gene cluster involve in microbial exopolysaccharide biosynthesis. (a) *gum* gene cluster responsible for xanthan biosynthesis in *Xanthomonas campestris* and (b) *eps* gene cluster involve in EPS biosynthesis in *Streptococcus thermophilus* Sfi6

consist of a limited number of different monosaccharide types or their derivatives and show a high diversity through various combinations of monosaccharide units arranged in linear or branched configurations. The most common backbone linkages of monosaccharide sequences are 1,4- β - or 1,3- β -linkages, which exhibit characteristic structural rigidity, while other linkages like 1,2- α - or 1,6- α -linkages are considered to have flexible structures. Extracellular polysaccharides are associated with each other and can also interact with other components of the EPS matrix, like proteins, lipids, inorganic ions, and other macromolecules of the bacterial cell surface (Meisen et al. 2008). The common components of bacterial exopolysaccharides are shown in ► Table 5.2.

Microbial extracellular polysaccharides can be divided into three groups on the basis of structural composition (Sutherland 1997). (1) Homopolysaccharides—These are comprised of a single structural unit that can be further categorized as (a) linear or (b) branched polymers. An example of a linear homopolysaccharide is bacterial cellulose (polyglucose). Branched homopolysaccharides are represented by levans (polyfructoses) and dextrans (polyglucose). (2) Heteropolysaccharides—These are composed of two or more structural repeating units with varying complexity. These have a regular structure and may also possess short side-chains. (3) Polysaccharides with irregular structure—A regular

structure is not defined for this group of polysaccharides. Alginate is one of the best examples of this group. It has two structural units—D-mannuronic acid and L-guluronic acid and composed of (a) blocks of 1,4-linked β -D-mannuronic acid (M), (b) blocks of 1,4-linked α -L-guluronic (G), and (c) mixed blocks (-M-G-) of alternating mannuronic acid and guluronic acid residues. Basic structures of the common exopolysaccharides are listed in ► Table 5.3.

A method was developed for determining the mass-molecular composition of microbial exopolysaccharides by Votselko et al. (1993). In this method, molecular mass composition of microbial exopolysaccharides (EPS) is determined by centrifuging EPS in a combined density gradient created by NaCl and CsCl solutions, and molecular mass of dextran is used as standard. EPS is preliminary assayed for total carbohydrate content using the phenol sulfuric acid method with glucose as standard (Dubois et al. 1956), while uronic acids are assayed by a spectrophotometric micromethod of color reaction of methyl pentoses (Dische and Shettles 1948) with glucuronic acid as standard. Sulfated sugars are determined by measuring sulfates after hydrolysis of the polymer with K_2SO_4 as standard (Terho and Hartiala 1971). The protein content of the EPSs is determined by Lowry method where BSA is taken as standard (Lowry et al. 1951). Major constitutive unit of extracellular polymers are sugars which are generally analyzed after acid

Table 5.2
Common components of bacterial exopolysaccharides (Kenne and Lindberg 1983)

Components	Example
Pentose sugars	D-arabinose
	D-ribose
	D-xylose
Hexose sugars	D-glucose
	D-galactose
	D-mannose
	D-allose
	L-rhamnose
	L-fucose
Amino sugars	D-glucosamine
	D-galactosamine
Uronic acids	D-glucuronic acids
	D-galacturonic acids
	D-mannuronic acid
Organic substituents	Acetate,
	Succinate
	Pyruvate
	Glycerate
	Hydroxybutanoate
Inorganic substituents	Sulfate
	Phosphate

hydrolysis. High-performance liquid chromatography (HPLC) with refractive index (RI)/UV detection is used for the qualitative and quantitative determination of various monosaccharides, oligosaccharides, and uronic acids present in the microbial exopolysaccharide. Gas chromatography–mass spectroscopy (GC-MS) is another and sensitive method applied for the determination of monomer units, but it requires conversion of monosaccharides to the partially methylated alditol acetates (PMAA). Identification of the PMAA is made by comparison of the mass spectra obtained with those of known standards. The functional groups and bonds present in EPS are analyzed by Fourier-transform infrared spectroscopy (FTIR) and nuclear magnetic resonance (NMR). Infrared spectroscopy reveals the fact that molecules possess specific frequencies at which they can rotate or vibrate corresponding to discrete energy levels (vibrational modes). These resonant frequencies are determined by the shape of the molecular potential energy surface, by the mass of the atoms, and by the associated vibronic coupling. Variation in stretching and bending modes of vibration with single functional group is usually coupled with the vibration of adjacent group, as well as with the number of substitution(s) taking place on the molecule itself. This leads to the shifting or overlapping of the peaks of two or more functional groups in the same region of IR

spectrum. The interpretation of infrared spectra involves the correlation of absorption bands in the spectrum of an unknown compound with the known absorption frequencies for different type of bonds. NMR spectroscopy is a powerful tool for studying the structure, function, and dynamics of biological macromolecules, widely used to determine chemical structure and conformational changes. The chemical structure of the EPS mucoidan was determined using ^1H and ^{13}C NMR spectroscopy and by conducting 2D DQF-COSY, TOCSY, HMQC, HMBC, and NOESY experiments (Urai et al. 2007). A FTIR and NMR spectrum of EPS is shown in [Figs. 5.3](#) and [5.4](#), respectively.

Energy dispersive X-ray spectroscopy (EDS or EDX) is one of the variants of X-ray fluorescence spectroscopy used for the elemental analysis of EPS. EDX relies on the investigation of a sample through interactions between electromagnetic radiation and matter, analyzing X-rays emitted by the matter in response to be hit with charged particles (Goldstein et al. 2003). A polymer can be considered crystalline or amorphous, and X-ray powder diffraction (XRD) is a rapid analytical technique most widely used for phase identification of EPS (Kavita et al. 2011; Mishra et al. 2011; Singh et al. 2011).

EPSs, obtained from marine bacterium *Vibrio parahaemolyticus*, seaweed associated-bacterium *Bacillus licheniformis* and microalgae *Dunaliella salina* are amorphous in nature with CI_{xrd} 0.092, 0.397, and 0.12, respectively (Kavita et al. 2011; Mishra et al. 2011; Singh et al. 2011). Crystallinity index (CI_{xrd}) is calculated from the area under crystalline peaks normalized with corresponding total scattering area, that is, ratio of areas of peaks of crystalline phases to the sum of areas of crystalline peaks and amorphous profile ([Eq. 5.1](#), Ricou et al. 2005). The crystalline domains act as a reinforcing grid and improve the performance of EPS over a wide range of temperatures. A typical XRD pattern of EPS extracted from *B. licheniformis* is shown in [Fig. 5.5](#):

$$CI_{xrd} = \left(\frac{\sum A_{crystal}}{\sum A_{crystal} - \sum A_{amorphous}} \right) \quad (5.1)$$

The applicability of exopolysaccharides is largely dependent on their thermal and rheological behavior. Thermogravimetric analysis (TGA) is a simple analytical technique that measures the weight loss of a material as a function of temperature. As temperature increases, an amorphous solid will become less viscous, and at a particular temperature, the molecules obtain enough freedom of motion to spontaneously arrange themselves into a crystalline state, known as the crystallization temperature (Dean 1995). This transition from amorphous solid to crystalline solid is an exothermic process, and differential scanning calorimetric analysis showed a significant thermal transition of EPSs ([Fig. 5.6](#)).

Matrix-assisted laser desorption—ionization mass spectroscopy is a convenient method for rapid and sensitive structural analysis of oligosaccharides (Harvey 1999). It was observed that MALDI TOF mass spectrometric analysis reveal a series of masses (m/z) corresponding to pentose and hexose sugars

■ Table 5.3
Common exopolysaccharides and structures

Exopolysaccharides	Source	Structure (backbone)
Acetan	<i>Acetobacter xylinum</i>	Branched homopolysaccharide of glucose (1 → 4 β) linkage with side chain: α-(1,3)- tetrasaccharides $[\beta\text{-D-Glc-(1} \rightarrow 4)\text{-}\beta\text{-D-Glc-}]_n$ $\downarrow[\alpha(1 \rightarrow 3)]$ $\text{Rha-}\alpha(1 \rightarrow 6)\text{Glc-}\beta(1 \rightarrow 6)\text{Glc-}\alpha(1 \rightarrow 4)\text{GlcA } \beta(1 \rightarrow 2)\text{Man}$
Alginate	<i>Pseudomonas aeruginosa</i> <i>Azotobacter</i> sp.	Polysaccharides with irregular structure: composed of variable proportions of 1,4-linked β-D-mannuronic acid (M) and its C-5 epimer α-L-guluronic (G) M blocks: [-D-ManUA-(1 → 4)β-] _n G blocks: [-L-GulUA-(1 → 4)α-] _n Mixed block: [DM(1 → 4)-LG-(1 → 4)-] _n
Alteran	<i>Leuconostoc mesenteroides</i>	Homopolysaccharide of glucose linkage alternating (1 → 3 β) and (1 → 6 β) $[\beta\text{-D-Glc-(1} \rightarrow 3)\text{-}\beta\text{-D-Glc-(1} \rightarrow 6)]_n$
Biodispersion	<i>Alteromonas</i> sp. <i>Alteromonas haloplanktis</i> <i>Alteromonas macleodii</i>	Heteropolysaccharide containing repeating tetrasaccharide units [L-Rha → 2-acetamido → 2-deoxy-D-Glu → 3-O-[(R)-1-carboxyethyl]-D-Glu] [D-Gal → 3-O-acetyl-2-acetamido-2-deoxy-DGlu → 2-acetamido-2-deoxy-L-guluronic acid → 3,6-dideoxy-3-(4-hydroxybutyramido)-D-Gal]
Cellulose	<i>Acetobacter xylinum</i> <i>Agrobacterium</i> sp., <i>Pseudomonas</i> sp., <i>Rhizobium</i> sp.	Linear homopolysaccharide of glucose (1 → 4 β) linkage $[\beta\text{-D-Glc-(1} \rightarrow 4)\text{-}\beta\text{-D-Glc-}]_n$
Curdlan	<i>Alcaligenes faecalis</i> var. <i>myxogenes</i>	Linear homopolysaccharide of glucose (1 → 3β) linkage $[\beta\text{-D-Glc-(1} \rightarrow 3)\text{-}\beta\text{-D-Glc-}]_n$
Cyclophorans	<i>Agrobacterium</i> sp., <i>Rhizobium</i> sp., <i>Xanthomonas</i> sp.	Cyclic (1 → 2)- β-D-glucans
Dextran	<i>Lactobacillus hilgardii</i> , <i>Leuconostoc mesenteroides</i> , <i>Leuconostoc dextranicum</i> , <i>Streptococcus mutans</i>	Branched homopolysaccharide of glucose (1 → 6 α) linkage with side chains α-(1,3)-; α-(1,4)- or α-(1,2)- $[\alpha\text{-D-Glc-(1} \rightarrow 6)\text{-}\alpha\text{-D-Glc-}]_n$ $\downarrow[\alpha(1 \rightarrow 3)]$ $[\text{D-Glc}(1 \rightarrow 6)\text{-}\alpha\text{-D-Glc-}]_m$ The exact structure of each type of dextran depends on the microbial strain
Emulsan	<i>Acinetobacter calcoaceticus</i>	Heteropolysaccharide containing repeating trisaccharide [GalNAc → GalNAcUA → an unidentified N-acetyl amino sugar]
Gellan	<i>Aureomonas elodea</i> , <i>Sphingomonas paucimobilis</i> , <i>Sphingomonas elodea</i>	Linear heteropolysaccharide of glucose, glucuronic acid, and rhamnose [-D-Glc-(1 → 4)β-D-GlcUA-(1 → 4)β-D-Glc(1 → 4) β -L-Rha(1 → 3)α-] _n
Hyaluronan (Hyaluronic acid)	<i>Streptococcus</i> sp.	Heteropolysaccharide of glucuronic acid and N-acetylglucosamine linkage alternating (1 → 4 β) and (1 → 3 β) [-DGlcUA-(1 → 4)β-DGalNAc-(1 → 3)β-]
Kefiran	<i>Lactobacillus hilgardii</i> , <i>L. rhamnosus</i> , <i>L. kefir</i> , <i>L. kefirnofasciens</i>	Heteropolysaccharide of glucose and galactose [-→6)β-DGlc-(1 → 2{6})β-DGal-(1 → 4)α-DGal-(1 → 3)β-DGal-(1 → 4) β-DGlc-(1) ₂₁ \downarrow → 6)β-DGlc-(1 → 2{6})β-DGal
Levan	<i>Alcaligenes viscosus</i> , <i>Zymomonas mobilis</i> , <i>Bacillus subtilis</i>	Branched homopolysaccharide of fructofuranosyl (2 → 6)β linkage with side chains β(2,1) [-→6)β-DFruf-(2 → 6)β-DFruf-] _n $\downarrow[\beta(2 \rightarrow 1)]$ $[-\rightarrow 6)\beta\text{-DFruf-(2} \rightarrow 6)\beta\text{-DFruf-}]_m$
Mutan	<i>Strep. mutans</i> , <i>Strep. sobrinus</i>	Branched homopolysaccharide of glucose(1 → 3α) linkage with side chains α-(1,6) $[\alpha\text{-D-Glc-(1} \rightarrow 3)\text{-}\alpha\text{-D-Glc-}]_n$ $\downarrow[\alpha(1 \rightarrow 6)]$ $[-\text{D-Glc}(1 \rightarrow 3)\text{-}\alpha\text{-D-Glc-}]_m$

■ Table 5.3 (Continued)

Exopolysaccharides	Source	Structure (backbone)
Succinoglucan	<i>Alcaligenes faecalis</i> var. <i>myxogenes</i>	Heteropolysaccharide of glucose and galactose linkage alternating (1 → 4 β) and (1 → 3 β) [β-D-Glc-(1 → 4)-β-D-Gal-(1 → 3)] _n
Welan	<i>Alcaligenes</i> species	Heteropolysaccharide of glucose, glucuronic acid, and rhamnose with side chains of n repeat of either L-rhamnose or L-mannose (1 → 4 α) or n repeat of glucose(1 → 6 α) units substituted on C3 of every 1,4 linked glucose repeating unit of backbone [D-Glc-(1 → 4)β-D-GlcUA-(1 → 4)βD-Glc(1 → 4) α-L-Rha/Man(1 → 3) β-] _n
Xanthan	<i>Xanthomonas. campestris</i>	Branched homopolysaccharide of glucose (1 → 4 β) linkage with side chains α-(1,3)- triasaccharides [β-D-Glc-(1 → 4)-β-D-Glc-] _n ↓[α(1 → 3)] Man-β(1 → 4) GlcA β(1 → 2)Man

Note: Adapted from Vandamme and Soetaert (1995), Sutherland (1997), Vu et al. (2009), Satpute et al. (2010)

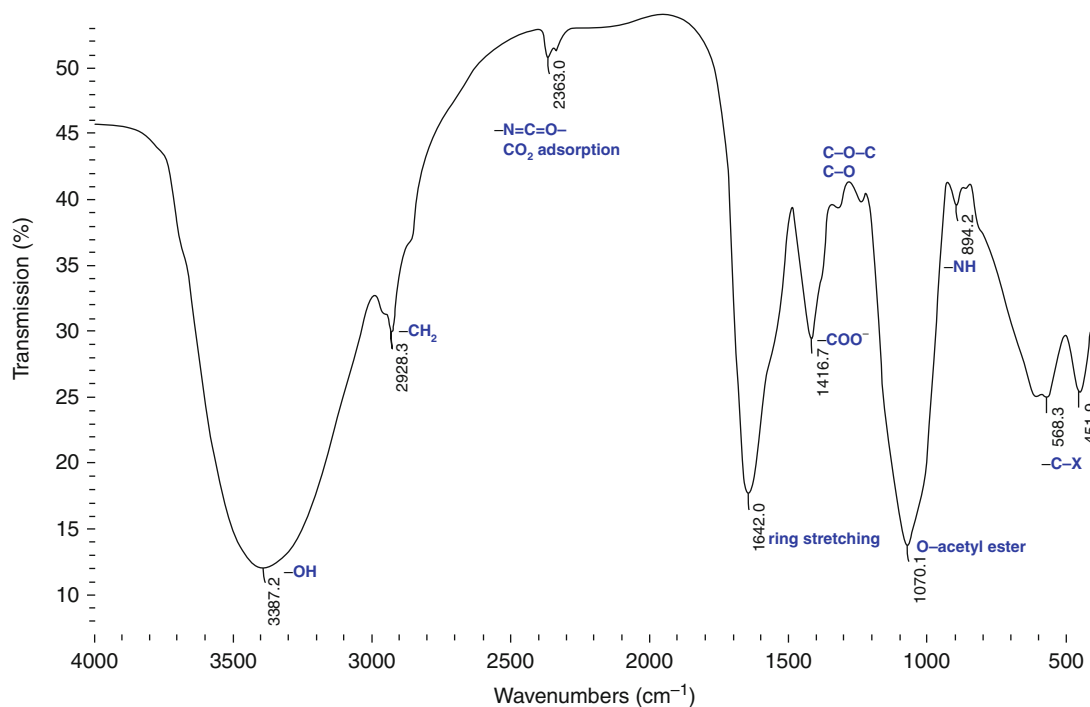

■ Fig. 5.3

FT-IR spectrum of EPS extracted from marine bacterium *Vibrio parahaemolyticus* (Kavita et al. 2011)

(150, 180) individually or combined as disaccharides (2 pentose—approx. 300, 1 pentose +1 hexose—approx. 330, and 2 hexose approx. 360) in midrange linear mode while positive ion reflector mode exhibited a higher range of masses m/z attributed to oligosaccharides comprised of hexose and pentose moiety linked in different combinations. Positive ion linear mode was found suitable for oligomers and reflector mode for polysaccharide analysis (Mishra et al. 2011). Recent progress in the surface and structure analysis of EPS has resulted from the development of advanced microscopy and spectroscopy techniques like

atomic force microscopy (AFM), confocal laser scanning microscopy (CLSM), infrared spectroscopy, nuclear magnetic resonance imaging (NMRI), Raman spectroscopy (RM), and scanning electron microscopy (SEM). The physicochemical properties and further applications of EPSs depend on its emulsifying activity in different solvents, rheological behavior under varying pH, temperature and stress, gel strength, binding ability toward metals, ions, biodegradability, immunogenicity, thermostability, nature, abundance (availability), and downstream processing (fermentation and commercialization).

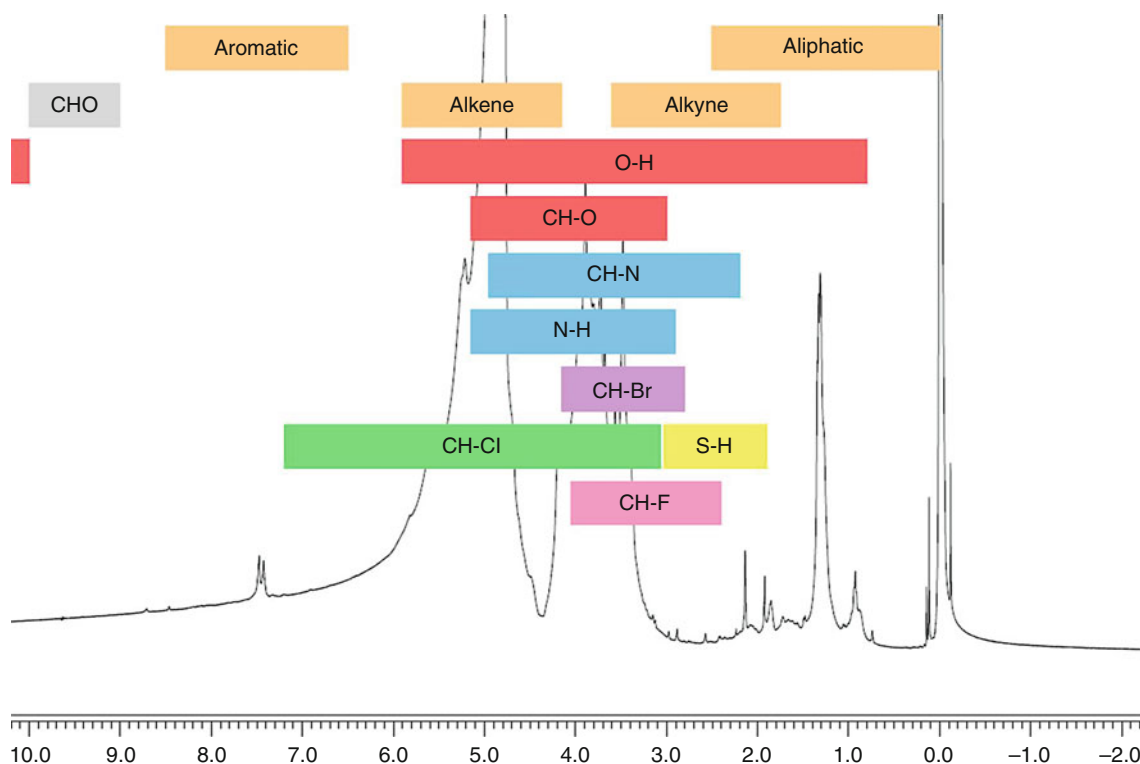

■ Fig. 5.4

A typical NMR spectrum of EPSs isolated from *Dunaliella salina* showing range of chemical shift (^1H , ppm) (Mishra et al. 2011)

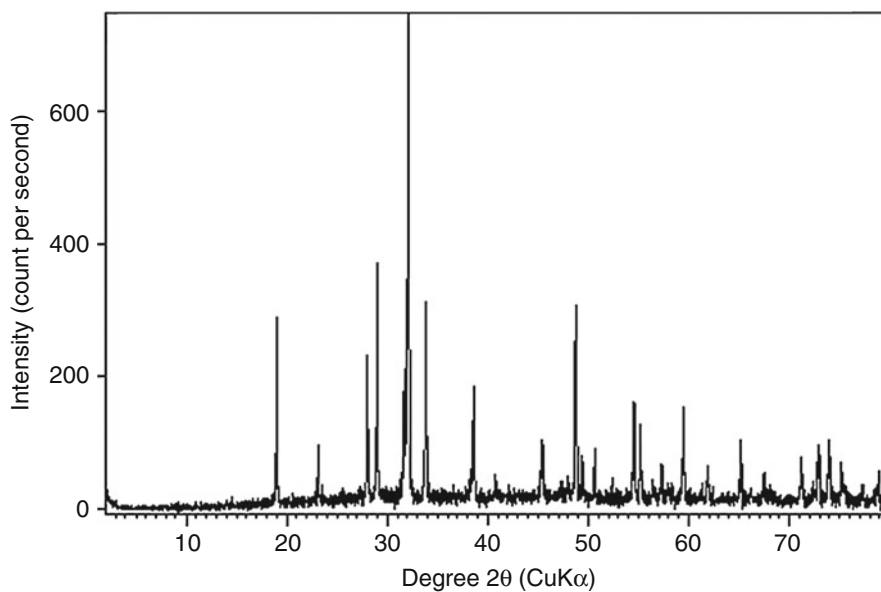

■ Fig. 5.5

XRD spectrum of EPS extracted from seaweed-associated bacterium *B. licheniformis* (Singh et al. 2011)

Common Exopolysaccharides: Property and Applications

Microbial exopolysaccharides have a wide range of applications depending on their nature, composition, and structure.

Generally a limited number of monosaccharides comprise EPS, and its structural diversity determines its possible applications. EPSs are used in the food, pharmaceutical, biomedical, bioremediation, and bioleaching fields because of their physical, rheological, some unique properties, and wide structural

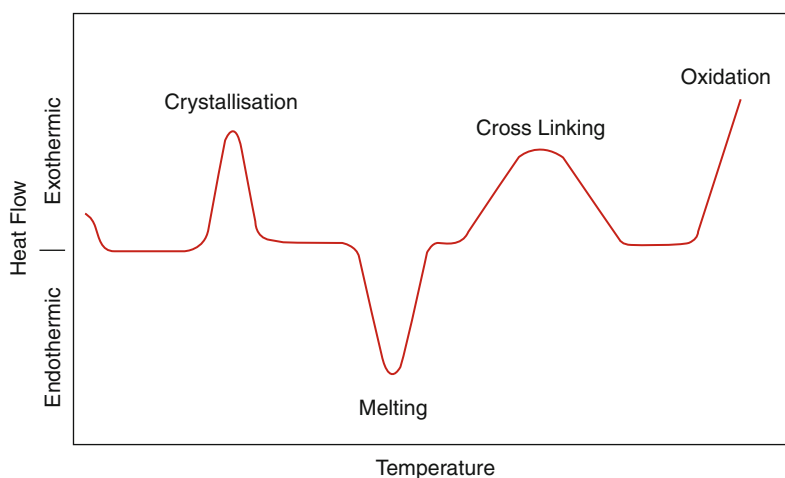

■ Fig. 5.6
A DSC thermogram of a polymer

diversity. Medicinal applications include antitumor, antiviral, and immunostimulant activities of exopolysaccharides produced by marine *Vibrio* and *Pseudomonas* as well as several other bacterial genera (Okutani 1984, 1992). A low molecular weight heparin-like exopolysaccharide was extracted from *Alteromonas infernus*, isolated from deep-sea hydrothermal vents, which contains anticoagulant property (Collicet et al. 2001). EPSs are also reported for the prevention of tumor cell development, formation of white blood cells and in the treatment of the rheumatoid arthritis (Vanhooren and Vandamme 2000). Owing to their low immunogenic properties, some low molecular weight exopolysaccharides are used as integral components of vaccines, adjuvant, or as carriers of antigenic proteins. Most of the EPSs have applications in food industries as gelling agent, and it was reported that gelrite, an exopolysaccharide isolated from *Pseudomonas* sp., is superior to agar (Lin and Casida 1984). EPSs are also used as surfactants and emulsifiers, which attracted attention because of their biodegradability (Rosenberg and Ron 1997). The flocculation and metals binding ability of EPS in solutions make its wide applications in the removal of heavy metals from the environment (Pal and Paul 2008). Thus, bioremediation of targeted pollutants such as heavy metals, hydrocarbons, petroleum, polycyclic aromatic hydrocarbons, microaromatics, polychlorinated biphenyls, chlorinated phenols, and aliphatics is one of the most important applications of EPS (Lynch and Moffat 2005). Apart from these, it is also used to enhance oil recovery (Sun et al. 2011). Biofilm-mediated bioremediation is an effective and safe method for removing pollutants from water (Singh et al. 2006). Bacterial exopolysaccharides play a key role in biofilm formation, facilitating initial adhesion leading to development of complex architecture. In contrast, antibiofilm activity was observed with an exopolysaccharide obtained from a marine *Vibrio* sp. (Jiang et al. 2011).

Xanthan has widespread applications in diverse fields like crude-oil recovery, paints industry, pesticide and detergent formulations, cosmetics, pharmaceuticals, printing inks, and food

sector (Vandamme and Soetaert 1995; Sutherland 1997; 1998; 1999; Kumar et al. 2007; Kumar and Mody 2009). Xanthan is an extracellular polysaccharide produced by the bacterium *Xanthomonas campestris* composed of homopolysaccharide D-glucose backbone with trisaccharide side chains, modified with differing proportions of O-acetyl and pyruvic acid acetal. Xanthan has remarkable emulsion stabilizing, particle suspension ability, and recoverable shear-thinning activity with high viscosities even at low concentration. Generally its viscosity does not change greatly on raising the temperature, and it is stable at both acid and alkaline pHs. It forms pseudoplastic dispersions in water and can also form gels in solution even with some nongelling polysaccharides. Xanthan gum has several applications and received GRAS (generally regarded as safe) listing for edible purposes. In the food sector, it is used in French dressing, for making cool packs and paper to wrap food stuffs, cottage cheese creaming emulsions, as a toothpaste stabilizer, cattle feed supplement, and calf milk replacer. Its shear-thinning characteristics is utilized in the paint industry as xanthan containing paints are highly viscous at low shear rates and thus will not drip from the brush. Its solution is also used as lubricant for drilling machines used in drilling muds at drilling oil wells.

Similar to xanthan, another and the only bacterial exopolysaccharide listed in GRAS is **gellan**, which is a product of the bacterium *Spingomonas paucimobilis* (Sutherland 2002). The physicochemical property of gellan that is of considerable interest is that it is highly viscous and shows high thermal stability (Banik et al. 2000). It is an excellent gelling agent, making clear, brittle gels at a lower concentration than agar (Lin and Casida 1984). Because naturally gellan is nongelling, it must be modified for commercial purposes and is available under the trade name of gelrite or phytogel (Banik et al. 2000). It is widely used as replacement of agar in culture media. As an elastic gel, it holds particles in suspension without altering the viscosity of the solution (Kumar and Mody 2009). Furthermore, it shows thermal and acid stability, elasticity and rigidity, and high transparency (Sutherland 1998; Banik et al. 2000;

Kumar and Mody 2009). Gellan is also used in pharmaceutical industries as a vehicle for ophthalmic drugs release (Carlfors et al. 1998). In the food sector, it is used in low calorie jams and jellies, as a fining agent for alcoholic beverages including beers, wines, and fortified wines (Sutherland 1998; Banik et al. 2000; Kumar and Mody 2009; Patel and Patel 2011).

Dextran is an important extracellular bacterial polysaccharide widely used as a molecular sieve for purification and separation of biomacromolecules, like proteins, nucleic acids, and polysaccharides, as matrices (e.g., SephadexTM) in size-exclusion chromatography (Naessens et al. 2005). Dextran is also used in clinical research as “clinical dextran,” a blood plasma substitute, in alleviate iron-deficiency anemia, and in confectionary to improve moisture retention, viscosity, and inhibit sugar crystallization (Sutherland 1997, 1998, 1999; Kumar et al. 2007; Kumar and Mody 2009).

Alginate or alginic acid is a well-known commercial product obtained from brown algae. It is also secreted by *Pseudomonas aeruginosa* and *Azotobacter vinelandii* as extracellular polysaccharides (Remminghorst and Rehm 2009). Applications of bacterial alginate include its uses as an emulsion stabilizer, gelling agent, thickener, foam stabilizer, suspending agent, viscosifier, film forming, or water-binding agent, and in the pharmaceutical industry for encapsulation of cells and enzymes for slow release and as wound dressings and dental materials. In the agriculture sector, it is used as a coating for roots of seedlings and plants to prevent desiccation, and as a microencapsulation matrix for fertilizers, pesticides, nutrients, etc. (Vandamme and Soetaert 1995; Sutherland 1998; Kumar and Mody 2009).

Hyaluronan or hyaluronic acid (HA) is a linear polymer and has significant structural, rheological, physiological, and biological functions. It is thought to possess properties that can affect angiogenesis, cancer, cell motility, wound healing, and cell adhesion and thus has a wide range of applications in the cosmetic and medicinal fields as skin moisturizers, in artificial tears, osteoarthritis treatment, as replacer of eye fluid in ophthalmic surgery, lubricant for the joints, for adhesion prevention in abdominal surgery, wound healing, and surface coating (Vandamme and Soetaert 1995; Yamada and Kawasaki 2005; Widner et al. 2005).

Exopolysaccharide **curdlan** has ability to form an elastic gel (gelatin) in aqueous suspension beyond approx. 55 °C (Dumitriu 2004) and is used in food and pharmaceutical industries to improve texture and stability of foods (heat processed food) and release of drugs, respectively (Gummadi and Kumar 2005; Kumar and Mody 2009). **Succinoglucon** is a glucose-galactose heteropolymer, which contains succinate and pyruvate moieties with similar applications as curdlan (Vandamme and Soetaert 1995). Since curdlan has no caloric value, it is useful in low-calorie foods (jams and jellies). During baking, it is used as a film to support immobilization of enzymes (Sutherland 1998). Bacterial **cellulose** is highly pure polymer and used in specific applications including food supplements such as a food matrix, dietary fiber, or thickening or suspending agents (Sutherland 1998). Besides this, it is used as a temporary artificial skin for

healing burns and surgical wounds in human (Vandamme and Soetaert 1995). Future application of bacterial cellulose is in separation technology as membranes or hollow fibers and as a special paper source (Vandamme and Soetaert 1995). Another microbial EPS **cyclophorans** has potential applications in encapsulation of drugs and food components (Vandamme and Soetaert 1995). EPS **welan** has stability and viscosity at elevated temperatures and thus is used at oil well-drilling sites. It is also use as a stabilizer and viscosifier in cement systems (Kumar and Mody 2009). Antibacterial, antifungal, and antitumor activity has been reported for the bacterial EPS, **kefiran** (Micheli et al. 1999; Kumar and Mody 2009). Kefiran is traditionally consumed and used in the formulation of self-carbonated, slightly alcoholic fermented milk (Duboc and Mollet 2001). In addition, it used to enhance viscosity of the dairy products. Recently, **levans** have drawn attention of researchers because of their prebiotic properties and wide scope in dairy industries. A cytotoxic effect against human cancer cell lines has been reported for a sulfated exopolysaccharide obtained from *Pseudomonas* sp. (Matsuda et al. 2003). Its application is now being extended toward development of new drugs to be used for pharmaceutical purposes (Laurienzo 2010).

Future Prospects

Microbial exopolysaccharides are preferred in industries owing to their novel functionality, reproducible physicochemical properties, stable cost, and supply. The increased demand of natural polymers for various industrial applications in recent past has led to an interest in EPS production by new sources. Most of the microbial world remains unexplored because of enormity of the biosphere and a large fraction of natural bacteria cannot be cultured by existing methods. Intelligent screening of microbes for novel exopolysaccharides is prerequisite for its further exploration toward commercialization. An advanced approach is needed for applications of exopolysaccharides in the medical or pharmaceutical field and food sectors. A multidisciplinary approach including microbiology, biochemistry, genetics, molecular biology, fermentation technology, dairy science, chemistry, etc., is imperative in order to develop novel industrially important biopolymers. Exopolysaccharides used in food sectors require further research and development to expand its use and to be listed in GRAS. In future, there will be further development of prebiotic and probiotic-based dairy products where bacterial exopolysaccharides will play a key role.

There are several reports regarding the novelty of exopolysaccharides extracted from marine bacteria and its pharmaceutical applications. Applicability and acceptability of exopolysaccharides in pharmaceutical industries has now opened a new avenue for the research to utilize novel bacteria that inhabit unexplored marine ecosystems. Microbial exopolysaccharides are constantly evolving, and advancement in biological techniques is required for its in vitro production. The main challenges for the commercialization of new microbial exopolysaccharides are the identification (of both strain

and exopolysaccharides nature), improvement of original structures, cost of production, and development of downstream process. There is a need of a suitable downstream process for the production and commercialization of exopolysaccharides. There are several problems associated with fermentation processes for the production of EPSs because of the properties of exopolysaccharides, such as high gel strength, viscosity, and foaming. More research is needed on fermentation technology to overcome these limitations. Further developments are also required for genetic engineering of microbes so they can more efficiently convert inexpensive raw materials to exopolysaccharides. In the light of current knowledge, an emphasis should be given to discover new microbial exopolysaccharides with potential multifarious applicability. In future years, there will be a quest for renewable resources and to preserve the ecosystem.

Acknowledgment

CSIR Network Project (NWP-0018) is thankfully acknowledged for research work conducted in the authors' laboratory. Authors are also thankful to Prof. Eugene Rosenberg for critically editing the manuscript.

References

- Andersson S, Dalhammar G, Rajarao GK (2011) Influence of microbial interactions and EPS/polysaccharide composition on nutrient removal activity in biofilms formed by strains found in wastewater treatment systems. *Microbiol Res* 166:449–457
- Anton J, Meseguer I, Rodriguez-Valera F (1988) Production of an extracellular polysaccharide by *Haloferax mediterranei*. *Appl Environ Microbiol* 10:2381–2386
- Banik R, Kanari MB, Upadhyay SN (2000) Exopolysaccharide of the gellan family: prospects and potential. *World J Microbiol Biotechnol* 16:407–414
- Becker A, Kuester H, Niehaus K, Puhler A (1995) Extension of the *Rhizobium meliloti* succinoglycan biosynthesis gene cluster: Identification of the *exsA* gene encoding an ABC transporter protein and the *exsB* gene which probably codes for a regulator of succinoglycan biosynthesis. *Mol Gen Genet* 249:487–497
- Bender J, Phillips P (2004) Microbial mats for multiple applications in aquaculture and bioremediation. *Bioresour Technol* 94:229–238
- Bermúdez J, Rosales N, Loreto C, Briceño B, Morales E (2004) Exopolysaccharide, pigment and protein production by the marine microalga *Chroomonas* sp. in semicontinuous cultures. *World J Microbiol Biotechnol* 20:179–183
- Bhaskar PV, Bhosle NB (2006) Bacterial extracellular polymeric substance (EPS): a carrier of heavy metals in the marine food chain. *Environ Int* 32:191–198
- Bramhachari PV, Dubey SK (2006) Isolation and characterization of exopolysaccharide produced by *Vibrio harveyi* strain VB23. *Lett Appl Microbiol* 43:571–577
- Bramhachari PV, Kavi-kishor PB, Ramadevi R, Kumar R, Rao BR, Dubey SK (2007) Isolation and characterization of mucous exopolysaccharide (EPS) produced by *Vibrio furnissii* strain VB0S3. *J Microbiol Biotechnol* 17:44–51
- Campbell JA, Davies GJ, Bulone V, Henrissat B (1997) A classification of nucleotide-diphospho-sugar glycosyltransferases based on amino acid sequence similarities. *Biochem J* 326:929–939
- Carlfors J, Edsman K, Peterson R, Jorning K (1998) Rheological evaluation of gelrite in situ for ophthalmic use. *Eur J Pharm Sci* 6:113–119
- Cheng HP, Walker GC (1998) Succinoglycan production by *Rhizobium meliloti* is regulated through the *ExoS-ChvI* two component regulatory system. *J Bacteriol* 180:20–26
- Chi Z, Zhao S (2003) Optimization of medium and cultivation conditions for pullulan production by a new pullulan-producing yeast. *Enzyme Microb Technol* 33:206–211
- Chi Z, Su CD, Lu WD (2007) A new exopolysaccharide produced by marine *Cyanotheca* sp. 113. *Bioresour Technol* 98:1329–1332
- Collic JS, Chevotot L, Helley D, Ratiskol J, Bros A, Sinquin C, Roger O, Fischer AM (2001) Characterization, chemical modifications and in vitro anticoagulant properties of an exopolysaccharide produced by *Alteromonas infernos*. *Biochim Biophys Acta* 1528:141–151
- Daniels C, Vindurampulle C, Morona R (1998) Overexpression and topology of the *Shigella flexneri* O-antigen polymerase (Rfc/Wzy). *Mol Microbiol* 28:1211–1222
- De Philippis R, Sili C, Paperi R, Vincenzini M (2001) Exopolysaccharide-producing cyanobacteria and their possible exploitation: A review. *J Appl Phycol* 13:293–299
- Dean JA (1995) *The analytical chemistry handbook*. McGraw Hill, New York
- Dische Z, Shettles LB (1948) A specific colour reaction of methyl pentoses and a spectrophotometric micro method for their determination. *J Biol Chem* 175:595–603
- Duan X, Chi Z, Wang L, Wang X (2008) Influence of different sugars on pullulan production and activities of α -phosphoglucose mutase, UDPG-pyrophosphorylase and glucosyltransferase involved in pullulan synthesis in *Aureobasidium pullulans* Y68. *Carbohydr Polym* 73:587–593
- Duboc P, Mollet B (2001) Applications of exopolysaccharides in the dairy industry. *Int Dairy J* 11:759–768
- Dubois M, Gilles KA, Hamilton JK, Rebers PA, Smith F (1956) Colorimetric method for determination of sugars and related substances. *Anal Chem* 28:350–356
- Dumitriu S (2004) Microbial exopolysaccharides. In: Dekker M (ed) *Polysaccharides: structural diversity and functional versatility*. CRC Press, New York, pp 431–457
- Gaceta P (1998) Bacterial alginate biosynthesis recent progress and future prospects. *Microbiology* 144:1133–1143
- Ganesh-Kumar C, Joo HS, Choi JW, Koo YM, Chang CS (2004) Purification and characterization of an extracellular polysaccharide from haloalkalophilic *Bacillus* sp. I-450. *Enzyme Microb Technol* 34:673–681
- Gerbersdorf S, Westrich B, Paterson DM (2009) Microbial extracellular polymeric substances (EPS) in fresh water sediments. *Microb Ecol* 58:334–349
- Glucksman MA, Reuber TL, Walker GC (1993) Genes needed for the modification, polymerization, export and processing of succinoglycan by *Rhizobium meliloti*: A model for succinoglycan biosynthesis. *J Bacteriol* 175:7045–7055
- Goldstein J, Newbury DE, Joy DC, Lyman CE, Echlin P, Lifshin E, Sawyer L, Michael JR (2003) *Scanning electron microscopy and X-ray microanalysis*, 3rd edn. Springer, Dordrecht
- Griffin AM, Morris VJ, J M (1996a) Identification, cloning and sequencing the *aceA* gene involved in acetan biosynthesis in *Acetobacter xylinum*. *FEMS Microbiol Lett* 137:115–121
- Griffin AM, Morris VJ, Gasson MJ (1996b) Genetic analysis of the acetan biosynthetic pathway in *Acetobacter xylinum*: nucleotide sequence analysis of the *aceB*, *aceC*, *aceD*, and *aceE* genes. *DNA Seq* 6:275–284
- Griffin AM, Poelwijk ES, Morris VJ, Gasson MJ (1997a) Cloning of the *aceF* gene encoding the phosphomannose isomerase and GDP mannose pyrophosphorylase activities involved in acetan biosynthesis in *Acetobacter xylinum*. *FEMS Microbiol Lett* 154:389–396
- Griffin AM, Edwards KJ, Morris VJ, Gasson MJ (1997b) Genetic analysis of acetan biosynthesis in *Acetobacter xylinum*: DNA sequence analysis of the *aceM* gene encoding an UDP-glucose dehydrogenase. *Biotechnol Lett* 19:469–474
- Gummadi SN, Kumar K (2005) Production of extracellular water insoluble β -1,3-glucan (curdlan) from *Bacillus* sp. SNC07. *Biotechnol Bioprocess Eng* 10:546–551
- Harvey DJ (1999) Matrix assisted laser desorption/ionization mass spectrometry of carbohydrates. *Mass Spectrom Rev* 18:349–451

- Jiang P, Li J, Han F, Duan G, Lu X, Gu Y, Yu W (2011) Antibiofilm activity of an exopolysaccharide from marine bacterium *Vibrio* sp. QY101. *PLoS One* 6: e18514
- Jiao Y, Cody GD, Harding AK, Wilmes P, Schrenk M, Wheeler KE, Banfield JF, Thelen MP (2010) Characterization of extracellular polymeric substances from acidophilic microbial biofilms. *Appl Environ Microbiol* 76(9):2916–2922. doi:10.1128/AEM.02289-09
- Katzen F, Ferreira DU, Oddo CG, Ielmini MV, Becker A, Pühler A, Ielpi L (1998) *Xanthomonas campestris* pv. *campestris* gum mutants: effects on xanthan biosynthesis and plant virulence. *J Bacteriol* 180:1607–1617
- Kavita K, Mishra A, Jha B (2011) Isolation and physico-chemical characterisation of extracellular polymeric substances produced by the marine bacterium *Vibrio parahaemolyticus*. *Biofouling* 27:309–317
- Kenne L, Lindberg B (1983) Bacterial polysaccharides. In: Aspinnall GO (ed) *The polysaccharides*, vol 2. Academic, New York, pp 287–363
- Kumar AS, Mody KH (2009) Microbial exopolysaccharides: variety and potential applications. In: Rehm BHA (ed) *Microbial production of biopolymers and polymer precursors: applications and perspectives*. Caister Academic, Norfolk, pp 229–254
- Kumar AS, Mody KH, Jha B (2007) Bacterial exopolysaccharides—a perception. *J Basic Microbiol* 47:103–117
- Laurienzo P (2010) Marine polysaccharides in pharmaceutical applications: an overview. *Mar Drugs* 8:2435–2465
- Lee HK, Chun J, Moon EJ, Ko SH, Lee DS, Lee HS, Bae KS (2001) *Hahella chejuensis* gen. nov., sp. nov., an extracellular polysaccharide producing marine bacterium. *Int J Syst Evol Microbiol* 51:661–666
- Lieberman M, Markovitz A (1970) Depression of guanosine diphosphate-mannose pyrophosphorylase by mutations in two different regulator genes involved in capsular polysaccharide synthesis in *Escherichia coli* K-12. *J Bacteriol* 101:965–972
- Lin CC, Casida LE (1984) Gelrite as a gelling agent in media for the growth of thermophilic microorganisms. *Appl Environ Microbiol* 47:427–429
- Liu D, Cole RA, Reeves PR (1996) An O-antigen processing function for Wzx (RfbX): a promising candidate for O-unit flippase. *J Bacteriol* 178:2102–2107
- Liu Y, Lam MC, Fang HHP (2001) Adsorption of heavy metals by EPS of activated sludge. *Water Sci Technol* 43:59–67
- Lowry OH, Rosenbrough NJ, Farr AL, Randall RJ (1951) Protein measurement with the folin phenol reagent. *J Biol Chem* 193:265–275
- Lynch JM, Moffat AJ (2005) Bioremediation prospects for the future application of innovative applied biological research. *Ann Appl Biol* 146:217–221
- Manzoni M, Rollini M (2001) Isolation and characterization of the exopolysaccharide produced by *Daedalea quercina*. *Biotechnol Lett* 23:1491–1497
- Margaritis A, Pace GW (1985) Microbial polysaccharides. In: Blanch HW, Drew S, Wang DIC (eds) *Comprehensive biotechnology. The practice of biotechnology: current commodity products*, vol 3. Pergamon Press, New York, pp 1005–1045
- Martínez-Cánovas MJ, Quesada E, Martínez-Checa F, Béjar V (2004) A taxonomic study to establish the relationship between exopolysaccharide-producing bacterial strains living in diverse hypersaline habitats. *Curr Microbiol* 48:348–353
- Martínez-Salazar JM, Moreno S, Najera R, Boucher JC, Espin G, Soberon-Chavez G, Deretic V (1996) Characterization of the genes coding for the putative sigma factor AlgU and its regulators MucA, MucB, MucC and MucD in *Azotobacter vinelandii* and evaluation of their roles in alginate biosynthesis. *J Bacteriol* 178:1800–1808
- Marx JG, Carpenter SD, Deming JW (2009) Production of cryoprotectant extracellular polysaccharide substances (EPS) by the marine psychrophilic bacterium *Colwellia psychrerythraea* strain 34H under extreme conditions. *Can J Microbiol* 55:63–72
- Mata JA, Béjar V, Llamas I, Arias S, Bressollier P, Tallon R, Urdaci MC, Quesada E (2006) Exopolysaccharides produced by the recently described halophilic bacteria *Halomonas ventosae* and *Halomonas anticariensis*. *Res Microbiol* 157:827–835
- Mata J, Béjar V, Bressollier P, Tallon R, Urdaci M, Quesada E, Llamas I (2008) Characterization of exopolysaccharides produced by three moderately halophilic bacteria belonging to the family Alteromonadaceae. *J Appl Microbiol* 105:521–528
- Matsuda M, Yamori T, Naitoh M, Okutani K (2003) Structural revision of sulfated polysaccharide B-1 isolated from a marine pseudomonas species and its cytotoxic activity against human cancer cell lines. *Mar Biotechnol* 5:13–19
- Maugeri TL, Gugliandolo C, Caccamo D, Panico A, Lama L, Gambacorta A, Nicolaus BA (2002) Halophilic thermotolerant *Bacillus* isolated from a marine hot spring able to produce a new exopolysaccharide. *Biotechnol Lett* 24:515–519
- McSwain BS, Irvine RL, Hausner M, Wilderer PA (2005) Composition and distribution of extracellular polymeric substances in aerobic flocs and granular sludge. *Appl Environ Microbiol* 71:1051–1057
- Meisen S, Wingender J, Telgheder U (2008) Analysis of microbial extracellular polysaccharides in biofilms by HPLC. Part I: development of the analytical method using two complementary stationary phases. *Anal Bioanal Chem* 391:993–1002
- Micheli L, Uccelletti D, Palleschi C, Crescenzi V (1999) Isolation and characterization of a rosy *Lactobacillus* strain producing the exopolysaccharide kefiran. *Appl Environ Microbiol* 53:69–74
- Mishra A, Jha B (2009) Isolation and characterization of extracellular polymeric substances from micro-algae *Dunaliella salina* under salt stress. *Bioresour Technol* 100:3382–3386
- Mishra A, Kavita K, Jha B (2011) Characterization of extracellular polymeric substances produced by micro-algae *Dunaliella salina*. *Carbohydr Polym* 83:852–857
- Muralidharan J, Jayachandran S (2003) Physicochemical analyses of the exopolysaccharides produced by a marine biofouling bacterium, *Vibrio alginolyticus*. *Process Biochem* 38:841–847
- Naessens M, Cerdobbel A, Soetaert W, Vandamme EJ (2005) *Leuconostoc* dextranucrase and dextran: production, properties and applications. *J Chem Technol Biotechnol* 80:845–860
- Nichols MC, Garon S, Bowman JP, Raguénès G, Guézennec J (2004) Production of exopolysaccharides by Antarctic marine bacterial isolates. *J Appl Microbiol* 96:1057–1066
- Nichols MC, Garon S, Bowman JP, Nichols PD, Gibson JAE, Guézennec J (2005) Chemical characterization of exopolysaccharides from Antarctic marine bacteria. *Microb Ecol* 49:578–589
- Nicolaus B, Lama L, Panico A, Schiano-Moriello V, Romano I, Gambacorta A (2002) Production and characterization of exopolysaccharides excreted by thermophilic bacteria from shallow, marine hydrothermal vents of fleegran areas (Italy). *Syst Appl Microbiol* 25:319–325
- Nicolaus B, Schiano-Moriello V, Lama L, Poli A, Gambacorta A (2004) Polysaccharides from extremophilic microorganisms. *Orig Life Evol Biosph* 34:159–169
- Okutani K (1984) Antitumor and immunostimulant activities of polysaccharides produced by a marine bacterium of the genus *Vibrio*. *Bull Jpn Soc Sci Fish* 50:1035–1037
- Okutani K (1992) Antiviral activities of sulfated derivatives of a fucosamine-containing polysaccharide of marine bacterial origin. *Nippon Suisan Gakk* 58:927–930
- Ortega-Morales B, Santiago-García J, Chan-Bacab M, Moppert X, Miranda-Tello E, Fardeau M, Carrero J, Bartolo-Pérez P, Valadéz-González A, Guezennec J (2007) Characterization of extracellular polymers synthesized by tropical intertidal biofilm bacteria. *J Appl Microbiol* 102:254–264
- Pal A, Paul AK (2008) Microbial extracellular polymeric substances: central elements in heavy metal bioremediation. *Indian J Microbiol* 48:49–64
- Parikh A, Madamwar D (2006) Partial characterization of extracellular polysaccharides from cyanobacteria. *Bioresour Technol* 97:1822–1827
- Patel RM, Patel VP (2011) Microbial polysaccharides: current innovations and future trends in medical science. *Curr Pharma Res* 1:204–209
- Pletikapić G, Radić TM, Zimmermann AH, Svetličić V, Pfannkuchen M, Marić D, Godrijan J, Žutić V (2011) AFM imaging of extracellular polymer release by marine diatom *Cylindrotheca closterium* (Ehrenberg) Reiman & J.C. Lewin. *J Mol Recognit* 24:436–445
- Poli A, Esposito E, Orlando P, Lama L, Giordano A, deAppolonia F, Nicolaus B, Gambacorta A (2007) *Halomonas alkaliartctica* sp. nov., isolated from

- saline lake Cape Russell in Antarctica, an alkalophilic moderately halophilic, exopolysaccharide producing bacterium. *Syst Appl Microbiol* 30:31–38
- Poli A, Anzelmo G, Nicolaus B (2010) Bacterial exopolysaccharides from extreme marine habitats: production, characterization and biological activities. *Mar Drugs* 8:1779–1802
- Qin K, Zhu L, Chen L, Wang PG, Zhang Y (2007) Structural characterization and ecological roles of a novel exopolysaccharide from the deep-sea psychrotolerant bacterium *Pseudoalteromonas* sp. SM9913. *Microbiology* 153:1566–1572
- Raguénès G, Pignet P, Gauthier G, Peres A, Christen R, Rougeaux H, Barbier G, Guezennec J (1996) Description of a new polymer-secreting bacterium from a deep-sea hydrothermal vent, *Alteromonas macleodii* subsp. *fijiensis*, and preliminary characterization of the polymer. *Appl Environ Microbiol* 62:67–73
- Remminghorst U, Rehm BHA (2009) Microbial production of alginate: biosynthesis and applications. In: Rehm BHA (ed) *Microbial production of biopolymers and polymer precursors: applications and perspectives*. Caister Academic, Norfolk, pp 13–42
- Ricou P, Pinel E, Juhasz N (2005) Temperature experiments for improved accuracy in the calculation of polyamide-11 crystallinity by X-ray diffraction. In: *Advances in X-ray analysis*, vol 48. International Centre for Diffraction Data, Newtown Square, Pennsylvania, USA, pp 170–175
- Roseman S (1972) Carbohydrate transport in bacterial cells. In: Hokin LE (ed) *Metabolic pathways*, vol 6. Academic, London/New York, pp 41–89
- Rosenberg E, Ron E (1997) Bioemulsans: microbial polymeric emulsifiers. *Curr Opin Biotechnol* 8:313–316
- Rougeaux H, Guezennec J, Carlson RW, Kervarec N, Pichon R, Talaga P (1999) Structural determination of the exopolysaccharide of *Pseudoalteromonas* strain HYD 721 isolated from a deep-sea hydrothermal vent. *Carbohydr Res* 315:273–285
- Satpute SK, Banat IM, Dhakephalkar PK, Banpurkar AG, Chopade BA (2010) Biosurfactants, bioemulsifiers and exopolysaccharides from marine microorganisms. *Biotechnol Adv* 28:436–450
- Sheng GP, Yu HQ, Yue ZB (2005) Production of extracellular polymeric substances from *Rhodospseudomonas acidophila*, in the presence of toxic substances. *Appl Microbiol Biotechnol* 69:216–222
- Singh R, Paul D, Jain RK (2006) Biofilms: implications in bioremediation. *Trends Microbiol* 14:389–397
- Singh RP, Shukla MK, Mishra A, Kumari P, Reddy CRK, Jha B (2011) Isolation and characterization of exopolysaccharides from seaweed associated bacteria *Bacillus licheniformis*. *Carbohydr Polym* 84:1019–1026
- Stanford PA (1979) Exocellular, microbial polysaccharides. In: Tipson RS, Horton D (eds) *Advances in carbohydrate chemistry and biochemistry*, vol 36. Academic, London/New York, pp 266–303
- Stingle F, Neeser JR, Mollet B (1996) Identification and characterization of the *eps* (exopolysaccharide) gene cluster from *Streptococcus thermophilus* Sfi6. *J Bacteriol* 178:1680–1690
- Subramanian BS, Yan S, Tyagi RD, Surampalli RY (2010) Extracellular polymeric substances (EPS) producing bacterial strains of municipal wastewater sludge: isolation, molecular identification, EPS characterization and performance for sludge settling and dewatering. *Water Res* 44:2253–2266
- Sun S, Zhang Z, Luo Y, Zhong W, Xiao M, Yi W, Yu L, Fu P (2011) Exopolysaccharide production by a genetically engineered *Enterobacter cloacae* strain for microbial enhanced oil recovery. *Bioresour Technol* 102:6153–6158
- Sutherland IW (1997) Microbial exopolysaccharides- structural subtleties and their consequences. *Pure Appl Chem* 69:1911–1917
- Sutherland IW (1998) Novel and established applications of microbial polysaccharides. *Trends Biotechnol* 16:41–46
- Sutherland IW (1999) Microbial polysaccharide products. *Biotechnol Genet Eng Rev* 16:217–229
- Sutherland IW (2001) Microbial polysaccharides from gram negative bacteria. *Int Dairy J* 11:663–674
- Sutherland IW (2002) A sticky business. *Microbial polysaccharides: current products and future trends*. *Microbiol Today* 29:70–71
- Terho TT, Hartiala K (1971) Method for determination of the sulfate content of glycosaminoglycans. *Anal Biochem* 41:471–476
- Tseng YH, Choy KT, Hung CH, Lin NT, Liu JY, Lou CH, Yang BY, Wen FS, Weng SF, Wu JR (1999) Chromosome map of *Xanthomonas campestris* pv. *campestris* 17 with locations of genes involved in xanthan gum synthesis and yellow pigmentation. *J Bacteriol* 181:117–125
- Urai M, Yoshizaki H, Anzai H, Ogihara J, Iwabuchi N, Harayama S, Sunairi M, Nakajima M (2007) Structural analysis of mucoidan, an acidic extracellular polysaccharide produced by a pristane-assimilating marine bacterium, *Rhodococcus erythropolis* PR4. *Carbohydr Res* 342:927–932
- Vandamme EJ, Soetaert W (1995) Biotechnical modification of carbohydrates. *FEMS Microbiol Rev* 16:163–186
- Vanhooren PT, Vandamme EJ (2000) Microbial production of clavans, an L-fucose rich exopolysaccharide. In: Bielecki S, Tramper J, Polak J (eds) *Food biotechnology*. Elsevier, Amsterdam, pp 109–114
- Votselko SK, Pirog TP, Malashenko YR, Grinberg TA (1993) A method for determining the mass-molecular composition of microbial exopolysaccharides. *J Microbiol Methods* 18:349–356
- Vu B, Chen M, Crawford RJ, Ivanova EP (2009) Bacterial extracellular polysaccharides involved in biofilm formation. *Molecules* 14:2535–2554
- Whitfield C (1988) Bacterial extracellular polysaccharides. *Can J Microbiol* 34:415–420
- Widner B, Behr R, Von-Dollen S, Tang M, Heu T, Sloma A, Sternberg D, DeAngelis PL, Weigel PH, Brown S (2005) Hyaluronic acid production in *Bacillus subtilis*. *Appl Environ Microbiol* 71:3747–3752
- Yamada T, Kawasaki T (2005) Microbial synthesis of hyaluronan and chitin: new approaches. *J Biosci Bioeng* 99:521–528
- Yamazaki M, Thorne L, Mikolajczak MJ, Armentrout RW, Pollock TJ (1996) Linkage of genes essential for synthesis of a polysaccharide capsule in *Sphingomonas* strain S88. *J Bacteriol* 178:2676–2687
- Zhang DY, Wang JL, Pan XL (2006) Cadmium sorption by EPSs produced by anaerobic sludge under sulfate-reducing conditions. *J Hazard Mater* 138:589–593
- Zou X, Sun M, Guo X (2006) Quantitative response of cell growth and polysaccharide biosynthesis by the medicinal mushroom *Phellinus linteus* to NaCl in the medium. *World J Microbiol Biotechnol* 22:1129–1133

6 Bacterial Enzymes

Wim J. Quax

University of Groningen, Groningen, The Netherlands

Introduction	193
Scientific Background: The Source of Enzymes	195
Commercial Applications	195
Starch	195
Amylases	196
Isomerases	197
Pullulanases and Cyclodextrin-Glucanotransferases	198
Detergents	198
Proteases	198
Lipases	199
Cellulases	200
Amylases	200
Mannanase	200
Food Processing	200
Textiles	201
Amylases	201
Cellulases	201
Proteases	201
Fine Chemicals	201
Amidases	201
β -Lactam Acylases	201
Other Amidases	203
Lipases and Esterases	203
Areas of Research	204
Feed	204
Phytases	204
Xylanases	204
Paper and Pulp	204
General Expression Hosts	205
Patents and Regulatory Systems	206
Regulations and Enzymes	206
Patents and Taxonomy	206
Prospects	206
Extremophiles	206
Directed Evolution	207

Introduction

In the living world, each chemical reaction is catalyzed by its own enzyme. Enzymes exhibit a high specificity, as they are able to discriminate between slightly different substrate molecules. Furthermore, they have the ability to operate at moderate temperature, pressure, and pH, which makes them attractive catalysts for industrial and household conversion processes. The first reports on the industrial use of enzyme products go back to the beginning of the last century. It was the German scientist Röhme who introduced the use of bovine pancreas extracts for the removal of stains in dirty clothing (Röhme 1915, Fig. 6.1). Around the same time, the Laboratoire Amylo in France experimented with the use of extract from *Bacillus* for conversion of starch into sugars (Fig. 6.2). As a result, the company Rapidase (Seclin, France), which is now part of the life science division of DSM, was formed. With the development of microbial fermentations in the second half of the last century, the number of industrial processes performed by enzymes and the amount of enzyme produced have increased sharply. At present, a renewed worldwide research effort has been directed to identifying more sustainable and environmentally friendly biocatalytic processes. The availability of highly specific and cheap enzymes resulting from genetic and protein engineering has been very instrumental in reviving interest in the industrial application of enzymes.

Most classically used industrial enzymes are hydrolytic (proteolytic, amylolytic, or lipolytic). Hydrolytic enzymes hardly require any cofactors, which allow their application in a great variety of conditions. These enzymes are usually separated from the cell broth after fermentation and formulated in more or less high concentrations. Recently, more specialized bioconversions have been developed in which enzymatic activity is maintained only by special cofactors that must be regenerated or, even worse, by living cells. In this chapter, the emphasis will be on bacterial enzymes that can be used in isolated form.

The organization of this chapter has focused on application. Owing to the versatility and stability of hydrolytic enzymes, the same enzyme may be used in totally different parts of industrial processes. Table 6.1 summarizes the current use of enzymes in various industry and household applications. The data are compiled from information provided by enzyme producers, customers, and industry organizations and from information acquired as a result of my involvement with industrial enzyme production for many years. As it relates to products of

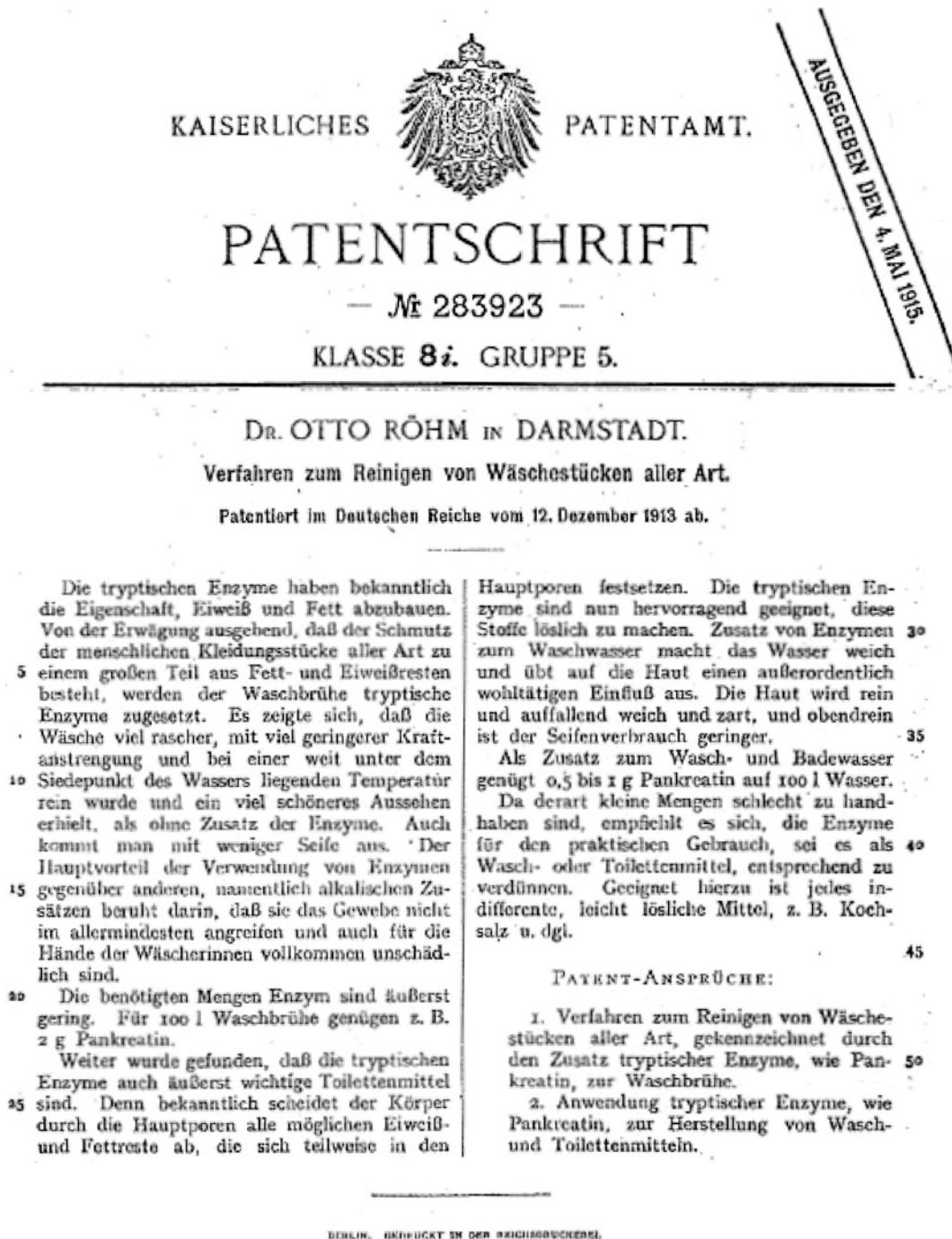

■ Fig. 6.1

A copy of the original patent by Röhm which describes for the first time the use of proteases as a cleaning aid

commercial importance, access to the data is not always possible, and relating the biochemical and genetic characteristics of production strains, which are usually proprietary, to better described strains in the literature is sometimes difficult. Nevertheless, this chapter should provide an overview of the importance of bacterial enzymes for sustainable and efficient conversion in industrial processes. Of the \$2.9 billion annual

world sales of industrial enzymes, about 50 % are sales of bacterial enzymes, and most of the remaining 50 % are sales of fungal enzymes. Background information on the specific enzymes available and their substrate specificities can be found in several databases (e.g., www.brenda-enzymes.org; www.sigmaaldrich.com/life-science/metabolomics/enzyme-explorer.html).

Scientific Background: The Source of Enzymes

Historically, the selection of microorganisms that produce enzymes has been empirical, starting with samples from very diverse natural sources. Cultures enriched by growth on substrates were used to inoculate fermentations. In a later stage, pure bacterial strains were selected. Intellectual property protections associated with bioprocesses have hampered the taxonomical characterization of industrially used strains. For the same reason, it is not always possible to trace the origin and history of currently used organisms. Once it

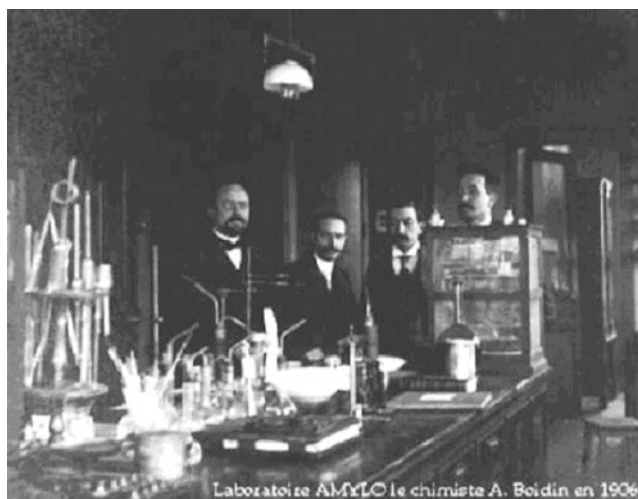

■ Fig. 6.2

The founders of the Rapidase Company the official website of the city of Seclin (France) (Source: <http://www.ville-seclin.fr/>, where the history of industrial activity including the “Usine Rapidase” is described)

■ Table 6.1

Bacterial enzymes and their field of application

	Starch	Detergents	Food	Biofuel	Textile	Fine chemicals	Brewing and juices	Paper and pulp	Feed
Amylases	+++++	++	++	++++	++	–	–	–	–
Proteases	–	+++++	++	–	+	–	+	–	–
Lipase	–	++	+	–		++++	–	–	–
Esterase	–	–	–	–		+++	–	–	–
Cellulase	–	++	+	++++		–	–	+	–
Glucanase	–	–	+	–		–	+++	–	–
Xylanase	–	–	+	++		–	++	++	+
Glucose isomerase	++++	–	–	–		–	–	–	–
β-Lactam acylase	–	–	–	–		++++	–	–	–
Phytases	–	–	–	–		–	–	–	++

Abbreviations: +++++ to +, the importance of the enzyme class to the specific use is graded on the basis of the amount of enzyme produced and its economic value; and –, enzyme of no importance to this use

became possible to protect man-made bacterial strains by a patent (Chakrabarty 1981), the taxonomy of the bacterial strains became a key element in the development of industrial enzymes. Ever since, the 16 S rRNA sequence has been routinely determined for every bacterial strain producing an enzyme with interesting properties (Jones et al. 1998). Later, the DNA sequence of the enzyme-encoding gene and its corresponding amino acid sequence became the key subjects for patent protection (Yamagata and Udaka 1994; Outtrup et al. 1998; van Solingen et al. 2001) because genetic engineering eliminated restrictions on enzyme production (i.e., the enzymes could be produced by both the original host bacterium and specialized expression hosts).

In general, early important criteria for evaluating enzyme technology included the ease of fermentation and recovery, lack of adverse side-products, yield, and finally the properties of the enzyme (see ▶ Table 6.2). It is no surprise that this emphasis on easily recovered enzymes has resulted in industrial production organisms that are predominantly secreting organisms. Gram-positive species with only a single membrane are highly represented among enzyme host cells. Especially bacilli known for their high secretory capability are often used. Nevertheless, in the absence of good alternatives, some interesting enzymes such as glucose isomerases expressed in *Streptomyces* (Jorgensen et al. 1988) are recovered from the cytoplasm of bacteria. Other products are secreted from Gram-negative organisms such as lipases from *Pseudomonas* (Gerritse et al. 1998a).

Commercial Applications

Starch

Starch, the primary storage polymer in higher plants, consists of a mixture of amylose (15–30 % w/w) and amylopectin

(70–85 % w/w). Amylose is composed of α -1,4-linked glucose units linked in linear chains of molecular weight ca. 60,000–800,000. Amylopectin is a branched polymer containing α -1,6 branch points every 24–30 glucose units (● Fig. 6.3); its molecular weight may be as high as 100 million (Buleon et al. 1998).

■ **Table 6.2**
Critical parameters for selecting an industrial enzyme

Enzyme activity
Specific activity (units/mg)
Application dosage
Stability during
Storage
Application
Immobilization for multiple use
pH range for activity and stability
Broad range of pH
Broad range of process conditions
Safety (allergenicity)
Nontoxic to men and environment
Nonallergenic
High-yield production
High-yield expression in bacterial host
Secretion for high yield and for easy purification

Corn (maize) starch represents 75 % of the world starch production. Virtually all of the 20 million ton world production of corn starch (Economic Research Service, personal communication) is converted into glucose by a two-step enzyme-catalyzed process involving (1) liquefaction of solid starch with an endoamylase into dextrans consisting of 7–10 molecules of glucose and (2) saccharification of the resulting liquefied starch with an exoamylase (glucoamylase) into single glucose monomers. The industrially most important endoamylases are α -amylases isolated from bacilli (Welker and Campbell 1967a; Aiba et al. 1983; Yuuki et al. 1985). The glucoamylase with the best industrial specifications is produced from the fungus *Aspergillus niger* (Reilly 1979). The produced glucose is used in more or less equal shares for the production of concentrated dextrose syrups, fuel ethanol, and high-fructose corn syrup.

Amylases

α -Amylase (EC 3.2.1.1) hydrolyzes starch, glycogen, and related polysaccharides by cleaving internal α -1,4-glucosidic bonds at random. The reports on the industrial use of bacterial amylase go back to the early 1920s, with a product trade named “Rapidase,” marketed by a European company with the same name. This enzyme, introduced to replace the acid hydrolysis process, which suffered from large salt loads and extreme yield losses, has long been classified as a product of *Bacillus subtilis*. Taxonomic data of the 1970s have revealed, however, that the

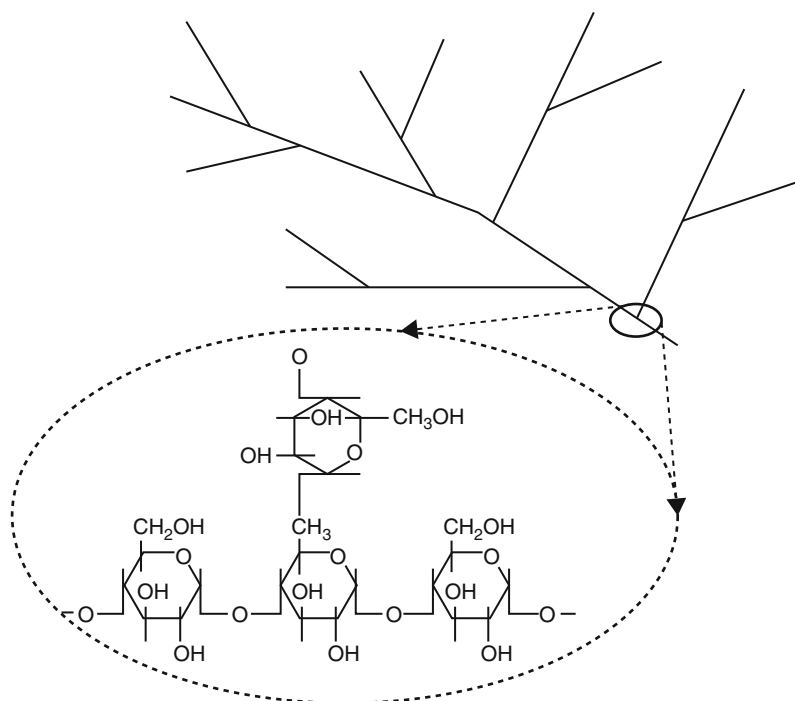

■ **Fig. 6.3**
Starch and actions of amylases on amylopectin. The 1,4 bonds (horizontal) are cleaved by α -amylases, and the 1,6 bonds (vertical), which are formed every 24–30 glucose units, can be cleaved by pullulanase (debranching enzyme)

production organism is a related but distinct species nowadays known as *Bacillus amyloliquefaciens* (Welker and Campbell 1967b). Notably the amylase (AmyE) from *Bacillus subtilis* 168 has no liquefying activity at all and is in fact unrelated. In the classical process, starch is first heated in a jet-cooking treatment that serves to open up the starch granules for gelatinization, and after cooling the mixture to 60 °C, the α -amylase is added to the starch.

In the early 1980s, a major change was introduced in the industry. Now the enzyme is added during the first step of the starch degradation process, and gelatinization occurs at high temperature (up to 110 °C), allowing the liquefaction during the steam explosion step. This has speeded up hydrolysis rates and decreased conversion costs significantly. The introduction of the more thermostable α -amylase from *Bacillus licheniformis* has been crucial for this improvement (Outtrup and Aunstrup 1975; Chandra et al. 1980; Edman et al. 1999). Next to the amylase from *Bacillus licheniformis*, the enzyme from *Bacillus stearothermophilus* has been introduced for industrial use. This enzyme, with stability slightly higher than that of the *Bacillus licheniformis* amylase, however, has never been widely used, since it generates maltodextrins in a size distribution that is unfavorable for the subsequent glucoamylase treatment. In an effort to combine the best properties of these two amylases, chimeric enzymes formed of the NH₂-terminal portion of *Bacillus stearothermophilus* α -amylase and the COOH-terminal portion of *Bacillus licheniformis* α -amylase have been made (Gray et al. 1986). The hybrid enzyme molecules, however, were shown to be less stable than each of the parent wild-type α -amylases. Finally, an enzyme mixture composed of the amylases from *Bacillus licheniformis* and *Bacillus stearothermophilus* was introduced with more success. Nowadays most commercial amylases are produced from a small subgroup of *Bacillus* species such as *Bacillus amyloliquefaciens*, *Bacillus coagulans*, *Bacillus licheniformis*, or *Bacillus stearothermophilus*. These enzymes show a high degree of homology and similarity (Yuuki et al. 1985; Nakajima et al. 1986).

Thermostability, pattern of breakdown into dextrins, ease of production, and activity at low pH (<6) are important criteria used industrially for choosing amylases. In recent years, the amylases in commercial use have been optimized by protein engineering and directed evolution. Enzyme properties such as heat stability, substrate specificity, or performance at different pH have been altered (Quax et al. 1991a; see also section **► “Prospects”** in this chapter). The generation of engineered variants and the availability of the corresponding cloned genes have inspired the development of host strains genetically engineered to optimize expression of amylases. To optimize yields in fermentation processes, classical mutagenesis was used to develop industrial strains for many decades, and much effort was made to develop transformation protocols and genetically stable multicopy systems for industrial host strains such as *Bacillus licheniformis* (Sanders et al. 1985). For efficiency and regulatory reasons, host strains of the same species or genus from which the α -amylase is derived are preferred (Jorgensen and Jorgensen 1993). Particularly for the production of mutant

amylases, a *Bacillus licheniformis* strain without a wild-type α -amylase gene and preferably a strain without other enzymatic activities such as proteases are used (Quax et al. 1991b). The α -amylases are produced throughout fermentation as a precursor with a signal sequence that is cleaved off during secretion, and secretion facilitates recovery. As a matter of fact, the secretion of amylase is so efficient that a potent expression/secretion system based on *Bacillus licheniformis* strain T9 and the amylase expression signals has been developed. This host strain has been at the basis of the PlugBug® concept that was introduced by Gist-brocades in the late 1980s (Quax et al. 1993). This system has been used to produce high amounts of both mutant α -amylases and human interleukin-3 (Van Leen et al. 1991).

Apart from the use of α -amylases for the production of sweeteners, the enzyme has also been applied in fuel ethanol production from liquefied starch (Kosaric et al. 1983). Though the demand for fuel ethanol is fluctuating, fuel ethanol has the potential to become a major product of cornstarch, and concomitant growth of the amylase supply will be required.

Isomerases

A major part of the glucose produced from starch liquefaction and saccharification is processed further into high-fructose corn syrup (HFCS). Eight million tons are produced worldwide (Economic Research Service, personal communication). Glucose isomerases (EC 5.3.1.5) catalyze the reversible isomerization of glucose to fructose. Fructose is now commonly used as a sugar substitute because it is sweeter than sucrose or glucose. Many microorganisms are known to produce glucose isomerase, see, for example, the review article by Wen-Pin Chen (1980), which lists a large number of microorganisms capable of producing glucose isomerase. The best producers of industrial glucose isomerases are from the *Actinomyces* group including *Streptomyces rubiginosus*, *Actinoplanes missouriensis*, and *Ampullariella* spp. (Quax et al. 1991b; Wong et al. 1991; Saari et al. 1987).

Activity on glucose (these enzymes are in fact xylose isomerases), no need for heavy metal cofactors (e.g., cobalt), amenability to immobilization, thermal stability (process conditions are at 55 °C), and ease of production are the most important features of glucose isomerases. Generally, the naturally occurring glucose isomerases also show a high affinity for sugars other than glucose, such as D-xylose, D-ribose, and L-arabinose. As a matter of fact, the K_m values for xylose are generally significantly lower and the V_{max} values usually higher than those for glucose, which is reflected in the official name of the enzyme (D-xylose ketol isomerase; EC 5.3.1.5). The enzyme causes glucose isomerization to fructose until about a 1:1 equilibrium mixture (the ratio present in natural sucrose) is formed, and the product has the same sweetness as sucrose. Because the enzyme is not secreted, its cost of production is relatively high. Therefore, glucose isomerase is immobilized in column reactors, allowing prolonged use of one batch of enzyme. Typically, the reactors operate for 60–100 days of continuous conversion at 55–60 °C.

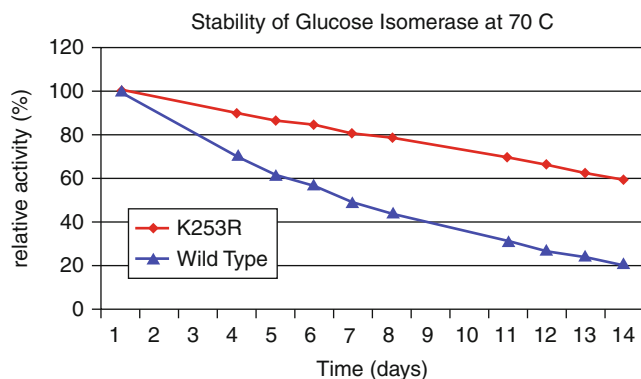

Fig. 6.4
The application test of protein-engineered, thermostable glucose isomerase. The activity of immobilized enzyme is plotted as a function of time. The stability at 70 °C indicates how the enzymes will behave under industrial conditions. The variant Lys253Arg of *Actinoplanes missouriensis* glucose isomerase has been shown to have (also under industrial conditions) a doubled half-life

Glucose isomerase requires a bivalent cation such as Mg^{+2} , Co^{+2} , or Mn^{+2} for its catalytic activity. Determination of three-dimensional (3D) structures of different glucose isomerases has revealed the presence of two metal ions in the monomeric unit (Kreft et al. 1983; Farber et al. 1987; Henrick et al. 1987). Apart from a role in the catalytic mechanism, bivalent cations are also reported to increase the thermostability of some glucose isomerases (Callens et al. 1988). Although the pH optimum of glucose isomerases is usually 7.0–9.0, use of glucose isomerase at lower pH is beneficial for the following reasons: (1) under alkaline conditions, the formation of colored by-products and a nonmetabolizable sugar (D-psicose) is a problem, and (2) the process step preceding the isomerization is performed at pH 4.5 (Roels and van Tilburg 1979). Despite an extensive screening of many microorganisms by industry researchers for a glucose isomerase with a higher activity at lower pH (Van Straten et al. 1997), no novel commercial glucose isomerase has been found.

Protein engineering has been used with more success to obtain glucose isomerases with a lower pH optimum (Drummond et al. 1989; Luiten et al. 1990; Zhu et al. 2000). The mutation of lysine253 into arginine253 of the isomerase from *Actinoplanes missouriensis* has almost doubled the operation time of the immobilized product under industrial conditions (Quax et al. 1991b, Fig. 6.4). In addition, technical optimizations such as an improved immobilization technique have enhanced the performance of traditional glucose isomerases such as that produced from *Streptomyces murinus* (Jorgensen et al. 1988). The mutants by definition are produced in genetically modified host strains. Also the classical nonmodified versions of the enzymes are nowadays being produced efficiently in nonsecreted form in genetically modified *Streptomyces* host cells. However, the exact nature of the strains and the genetic constructions used by industry for these purposes are poorly documented.

Pullulanases and Cyclodextrin-Glucanotransferases

The endoamylases cyclomaltodextrinase (CGTase, EC 3.2.1.54), maltogenic amylase (EC 3.2.1.133), and neopullulanase (EC 3.2.1.135) are minor enzymes capable of hydrolyzing two or three of the following: cyclomaltodextrins, pullulan, and starch. These enzymes hydrolyze cyclomaltodextrins and starch to maltose, and pullulan to panose, by cleavage of α -1,4 glycosidic bonds (see Fig. 6.3), whereas α -amylases are essentially inactive on cyclomaltodextrins and pullulan. Uniquely, pullulanases are also able to cleave the α -1,6 bonds (see Fig. 6.3), which makes them especially important for completely converting starch into glucose monomers. Pullulanases have been described from many species, but the enzyme from *Bacillus acidopullolyticus* seems to be specially suited for use in the starch-processing industry (Kelly et al. 1994).

The cyclodextrins produced from glucose have applications ranging from the formulation of pharmaceuticals to surfactants (solubility enhancers; Hesselink et al. 1989; Albers and Muller 1995). The right endoamylase for cyclodextrin production should act quickly and yield the desired product spectrum at high temperatures and low pH. The enzymes from *Bacillus coagulans* and *Bacillus circulans* are well known in the market (Kitahata et al. 1983; Hofmann et al. 1989). Recently, variants of cyclodextrin-glucanotransferases (CGTases) with an altered cyclodextrin product spectrum have been engineered by mutagenesis of specific residues (Norris et al. 1983; Wind et al. 1998).

Detergents

Proteases

Subtilisins (EC 3.4.21.62), a large class of microbial serine proteases, are responsible for the breakthrough in industrial enzyme development. As early as 1959, the Swiss company Gebrüder Schnyder AG marketed the first detergent powder with a protease produced from a *Bacillus* strain under the name Bio 40. Schweizerische Ferment AG in Basel delivered the protease. The name of the enzyme, subtilisin, refers to the producing organism *Bacillus subtilis*. In 1963, the Dutch company Kortmann and Schulte marketed the first bacterial enzyme-cleaning product (Biotex® with Alcalase®), and it became a big success. Alcalase®, the major extracellular serine protease from *Bacillus licheniformis*, was manufactured by the Danish company Novo (now Novozymes). Between 1965 and 1966, the big soap producers (Procter and Gamble, Unilever, Colgate, and Henkel) realized the potential of the hydrolytic action of bacterial protease in removing protein-based stains, and they began adding Alcalase® and a similar product, Maxatase®, to their major detergent brands. This has led to the creation of a worldwide industrial enzyme market based on *Bacillus licheniformis* fermentation. Proteases hydrolyze the peptide bonds of proteins staining fabric, releasing smaller polypeptides and individual amino acid units. In 1969, a major drawback (fatal allergic

reactions of employees exposed to dust set free during enzyme production) became apparent. Thanks to improved dust-free formulations, the enzyme industry was able to recover. To satisfy the desire to lower the temperature and concomitantly increase the alkalinity of laundry processes, extreme alkaline proteases (Maxacal[®] originating from *Bacillus alcalophilus* [Van Eekelen et al. 1988; Van der Laan et al. 1991] by Gist-brocades and Savinase[®] from *Bacillus lentus* [Betzel et al. 1988] by Novo-Nordisk) were introduced into the market in the early 1980s. Interestingly, the gene sequences showed that these proteases differed by only a single amino acid. Recently, the strain producing Savinase[®] has been reclassified as *Bacillus clausii* (Christiansen et al. 2002). The gene for the Alcalase[®] serine protease, also known as Carlsberg subtilisin, was cloned in 1985 (Jacobs et al. 1985). The availability of the cloned genes and detailed 3D structures of various subtilisin molecules (Drenth et al. 1972; McPhalen and James 1988; Van der Laan et al. 1992) has facilitated protein-engineered improvements in enzymes and their adaptation to the detergent matrix. More stable variants and especially more bleach-stable variants, which were obtained by substituting the methionine residue next to the active site serine, are dominating the marketplace today (Estell et al. 1985; Van Eekelen et al. 1989). For liquid detergent application, the more neutral subtilisin BPN-P originating from *Bacillus amyloliquefaciens* has been the product of choice for many years. In the United States, about 50 % of liquid detergents and 25 % of powder detergents contain proteases for improved cleaning. In Europe where powder detergents are more popular, virtually all brands have protease additives.

Lipases

After the successful introduction of proteases for the removal of proteinaceous stains in laundry detergents, the next challenge was the development of lipases for the removal of greasy stains. The search for suitable lipases however turned out to be far more difficult than the introduction of proteases.

Detergent lipases were selected according to the following criteria: (a) broad activity on a variety of fats and lipids, (b) stability in alkaline detergent formulations, (c) sufficient solubility in water to soak into fabrics, (d) compatibility with proteases present in detergent formulations, and (e) ease of production. The first lipase introduced in detergent powder is a lipase of fungal origin that fits well with criteria (c) and (e). However, owing to the acidophilic nature of fungi, the compatibility of their lipases with the alkaline conditions in detergents is poor. Therefore, bacterial lipases (EC 3.1.1.3) originating from *Pseudomonas* species have received much attention. Especially the lipase from *Pseudomonas alcaligenes* has an excellent activity in the pH range compatible with detergent conditions. Criterion (e) is however far more problematic for fungal lipase production. The expression in heterologous host strains such as *Bacillus* or *Escherichia coli* turned out to be impossible because a lipase-specific chaperone Lif (El-Khattabi et al. 1999) or LipB was required. Furthermore, the lipase is secreted via the terminal

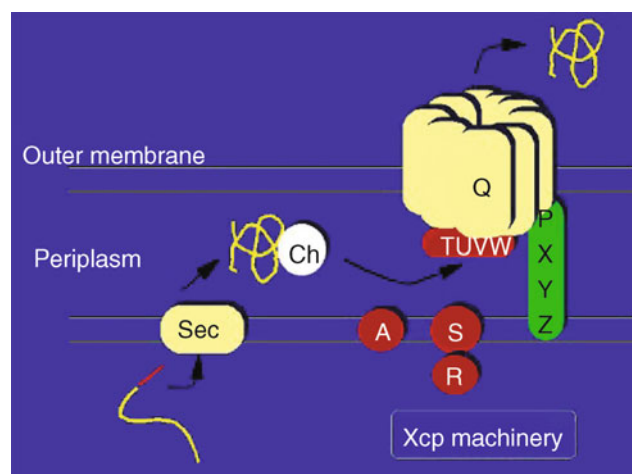

■ Fig. 6.5

The secretion machinery of *Pseudomonas alcaligenes*, the producer of Lipomax[®], an alkaline lipase for detergent compositions. The XcpQ protein forms a multimeric ring in the outer membrane. The Xcp T, U, V, and W proteins are thought to be involved in the gating of the pore, and proteins P, X, Y, and Z form a connection between the outer membrane pore and the inner membrane. XcpA, S, and P play a role in the processing of other Xcp proteins. Sec is inner membrane translocase. Ch is the periplasmic chaperone

branch of the general secretion pathway (Xcp-machinery), which involves very specific interactions (for a review, see Filloux et al. 1998, ● Fig. 6.5). Apart from the expression yield also the recovery of *Pseudomonas* lipases from the fermentation broth requires special processes owing to the hydrophobic nature of lipases and the presence of lipopolysaccharides. Despite these obstacles, the lipase from *Pseudomonas alcaligenes* was introduced as a detergent additive in 1995 by Gist-brocades under the trade name Lipomax[®] (Gerritse et al. 1998b; Cox et al. 2001). As a result of a stepwise improvement of the production strain and fermentation process, commercially viable yields of lipase were obtained (Gerritse et al. 1998a, b; Cox et al. 2001).

As most lipases do not meet all the above-mentioned criteria, the first protein engineering of lipases was based on amino acid sequence information only (e.g., the study on lipase from *Pseudomonas mendocina*; Gray et al. 1995). When the first 3D structures became available in the late 1980s, protein engineering efforts increased dramatically. A European-wide-funded project focused on solving new lipase structures, and now more than 15 X-ray structures of lipases are available in the protein database (PDB), of which 12 are microbial and five are of prokaryotic origin. The X-ray structure of lipase containing a phosphonate inhibitor covalently bound to its active site serine revealed that a lid was displaced from the active site by a hinge bending movement, creating an increased hydrophobic surface. Many of the lipase structures are solved in both a closed and an open conformation, that is, with the lid or lids displaced from

■ **Table 6.3**

Three-dimensional structures of prokaryotic lipases

Species	Molecular weight (kDa)	Structure ^a	References
<i>Burkholderia glumae</i> (<i>Pseudomonas glumae</i> , <i>Chromobacterium viscosum</i>)	23	PDB1QGE	Noble et al. (1994)
<i>Pseudomonas aeruginosa</i>	30	PDB1EX9	Nardini et al. (2000)
<i>Bacillus subtilis</i>	19	PDB1I6W	van Pouderoyen et al. (2001)
<i>Burkholderia cepacia</i> (<i>Pseudomonas cepacia</i>)	33	PDB2LIP	Schrag et al. (1997)
<i>Bacillus stearothermophilus</i>	43	PDB1KU0	Jeong et al. (2002)

^aCode name for the corresponding file in the Protein Database Bank (www.rcsb.org/pdb) (PDB code)

the active site. A list of selected solved bacterial lipase structures is given in ► [Table 6.3](#). The overall structure of the triacylglycerol lipases has a central L-sheet with the active serine placed in a loop termed the “catalytic elbow.” Above the serine, a hydrophobic cleft is present or formed after activation of the lipases. Molecular modeling of these structures has been used to construct models of lipase homologues (e.g., the engineering of the *Pseudomonas alcaligenes* lipase; Aehle et al. 1995). The use of lipases for the generation of enzymatic peroxide bleach in detergents has been pioneered but not yet applied.

Cellulases

Cellulases are enzymes capable of hydrolyzing the 1,4 β-D-glucosidic linkages in cellulose. Cellulolytic enzymes have been traditionally divided into three major classes: endoglucanases, exoglucanases (or cellobiohydrolases), and β-glucosidases (Knowles et al. 1987). A large number of bacteria, yeasts, and fungi are known to produce this group of enzymes. Initially, cellulolytic enzymes have been developed for application in converting wood and cellulose pulp into sugars for bioethanol production. Later on, it was discovered that cellulases can be used for the treatment of textiles. For example, repeated washing of cotton-containing fabrics results in a grayish cast to the fabric, which is believed to be due to fibrils disrupted and disordered by mechanical action. This grayish cast, sometimes called “pills,” is particularly noticeable on colored fabrics. The ability of cellulase to remove the disordered top layer of the fiber and thus improve the overall appearance of the fabric has been used to recondition used fabrics to make their colors more vibrant.

Despite the availability of fungal cellulases having some of the above properties, new cellulases that are more compatible

with the alkaline detergent formulations have been sought. Alkaliphilic *Bacillus* species have been found to express cellulases (EC 3.2.1.4) with excellent properties for detergent conditions, and one of these cellulases is now expressed from *Bacillus subtilis* and marketed under the trade name Puradax® (Jones and Quax 1998). Also, cellulases from *Thermomonospora fusca* have been found to be of interest (Irwin et al. 1998) to textile decolorators. Some of these cellulases can be abundantly expressed in a *Streptomyces lividans* host cell (Jung et al. 1993).

Amylases

The thermostable α-amylase (EC 3.2.1.1) from *Bacillus licheniformis* is perfectly compatible with detergent conditions, and nowadays small amounts of this enzyme are widely added to detergent powder formulations for the removal of starch stains. A protein-engineered variant, Purastar® Ox, has been developed specifically for inclusion in bleach-containing detergent formulations (Genencor 2001). This brings the number of different enzyme systems added to modern detergent powders up to four: proteases, lipases, cellulases, and amylases.

Mannanase

Guar gum-based stains (e.g., ice cream, sauces) can be removed more effectively with the addition of mannanases to detergent powders.

Food Processing

Microorganisms play a major role in the processing of dairy products, beer, wine, and many other food products. Isolated enzymes are also being used in specialized processes, although in much smaller amounts than are used in the immense starch-processing industry, which will be discussed in a separate chapter.

The baking of bread is one of the oldest biotechnological processes known to man. Yeast enzymes and endogenous flour enzymes are the primary modifiers and metabolizers of flour sugars and proteins. However, the levels of endogenous enzymes vary considerably depending on wheat growth, harvest, and storage conditions. Correction and supplementation of the flour with bacterial enzymes result in more tasteful and better quality bread. *Bacillus amyloliquefaciens* α-amylase (EC 3.2.1.1) is used to obtain an improved loaf volume and crumb structure (Lin and Lineback 1990). In addition, α-amylase contributes to anti-staling by mildly hydrolyzing starch polymers, which prevents their crystallization and thereby hardening of bread. The neutral protease of the same bacterium is used for improving the rheological properties of biscuit and cracker dough (Lyons 1982). This protease fragments the gluten protein in wheat flour, which gives the dough its elastic properties. As a result, the dough requires a reduced fermentation time, and the resulting biscuits have a prolonged freshness.

Dairy products and beverages are processed under mildly acidic conditions favoring the use of enzymes of fungal origin. However, in the processing of beer, the enzymes from selected *Bacillus* strains play an essential role. The α -amylase from *Bacillus amyloliquefaciens* is used to improve the enzymatic liquefaction potential of the malt. A β -glucanase from the same bacterium (Hofemeister et al. 1986) is used to reduce the viscosity of the wort, which improves the filtration of the beer.

Textiles

Amylases

Woven fabrics from natural plant and animal fibers represent the oldest forms of textile. The introduction of mechanical processes in the nineteenth century prompted the introduction of protective agents to prevent warp-end breaks. Starch added as a sizing agent strengthens fibers and makes the yarn more resistant to high mechanical stress during the weaving process. Traditionally, malt extracts and animal-derived preparations have been used to remove starch-based thickeners in the desizing operation. However, as early as 1917, a high-temperature stable bacterial enzyme preparation obtained by dedicated fermentation was introduced (Wallerstein 1939). Today we know that the bacterium used was *Bacillus amyloliquefaciens* (Welker and Campbell 1967a). At present both *Bacillus amyloliquefaciens* and *Bacillus licheniformis* α -amylases are being used for this process.

Cellulases

In various treatments of cotton fibers, these enzymes have resulted in better wash-down effects, resistance to pilling, softening, and better dye uptake. Later it was discovered that the enzymatic treatment of textiles could result in decorative effects on clothing similar to the stone washing of denim (Gusakov et al. 2000). This has resulted in a large market for cellulases in providing a worn look to jeans. The enzymatic production of stone-washed denim products (no need for pumice) has become a fast growing market with more than \$40 million in sales per year. A variety of cellulase products (many of fungal origin) is marketed for this purpose. Recently, enzymes from the actinomycete *Thermomonospora fusca* have been developed (Spezio et al. 1993). The cellulase (EC 3.2.1.4) can be efficiently produced from a genetically engineered *Streptomyces lividans* (Jung et al. 1993). Care needs to be taken to prevent loss of fiber strength from cellulase treatment that is too lengthy or intense.

Proteases

These enzymes (e.g., subtilisin [EC 3.4.21.62]) are used to treat protein fabrics such as wool and silk. By breaking down the fibrils on the surface, the look and feel of the fabric can be softened.

Fine Chemicals

In nature, a huge repertoire of chemical transformations is catalyzed by many thousands of enzymes. Its precise 3D architecture allows each enzyme to exhibit a remarkable specificity for the conversion of a particular set of substrates. The introduction of these enzymes as biocatalysts in the industrial production of fine chemicals probably represents the uppermost innovation in the enzyme field in recent years. Since a company produces in-house many of the biocatalysts used within industrial processes (i.e., production for captive use or captive consumption), the information on the actual scale and commercial impact of many of these biocatalytic processes is often limited. Nevertheless, from the scarce publications on industrial use of biocatalysts, it can be concluded that numerous energy intensive chemical processes involving a high output of pollutants have now been replaced by environmentally friendly enzymatic processes (Schmid et al. 2001).

Amidases

β -Lactam Acylases

Penicillin G acylase (benzylpenicillin amidohydrolase, also named “penicillin amidase”; EC 3.5.1.11) is an enzyme used commercially to produce 6-aminopenicillanic acid (6-APA), the most important intermediate for the industrial production of semisynthetic penicillins. This is achieved by the hydrolysis of penicillin G (for review, see Bruggink et al. 1998,  Fig. 6.6, left column).

Numerous bacterial species have been described in the literature as penicillin G acylase-producing strains, but only certain strains of the species *E. coli*, *Kluyvera citrophila*, and *Alcaligenes faecalis* were found to produce an enzyme compatible with the requirements of industrial deacylation (Balasingham et al. 1972; Barbero et al. 1986; Verhaert et al. 1997). Driven by environmental legislation in the past decade, all chemical deacylation processes in industry have been replaced by the less polluting enzymatic cleavage process. Recombinant DNA methods have been applied not only to increase the yields of commercially used penicillin G acylases (Bruns et al. 1985) but also to decipher the complex processing of these enzymes (Schumacher et al. 1986). The penicillin G acylase of *E. coli* ATCC11105 was found to be produced as a large precursor protein, which is secreted into the periplasm and further processed to the mature protein constituting a small (α) and a large (β) subunit. Cloning and sequencing has revealed a close homology (90 % identity) to the *Kluyvera citrophila* and a distant homology (50 % identity) to the *Alcaligenes faecalis* acylase gene. The heterodimeric structure, however, is evolutionarily preserved not only among penicillin acylases but also within the much larger family of β -lactam acylases.

Whereas the conversion of penicillin G requires an enzyme with a specificity for the aromatic phenyl acetate side chain, the processing of the second largest β -lactam fermentation product,

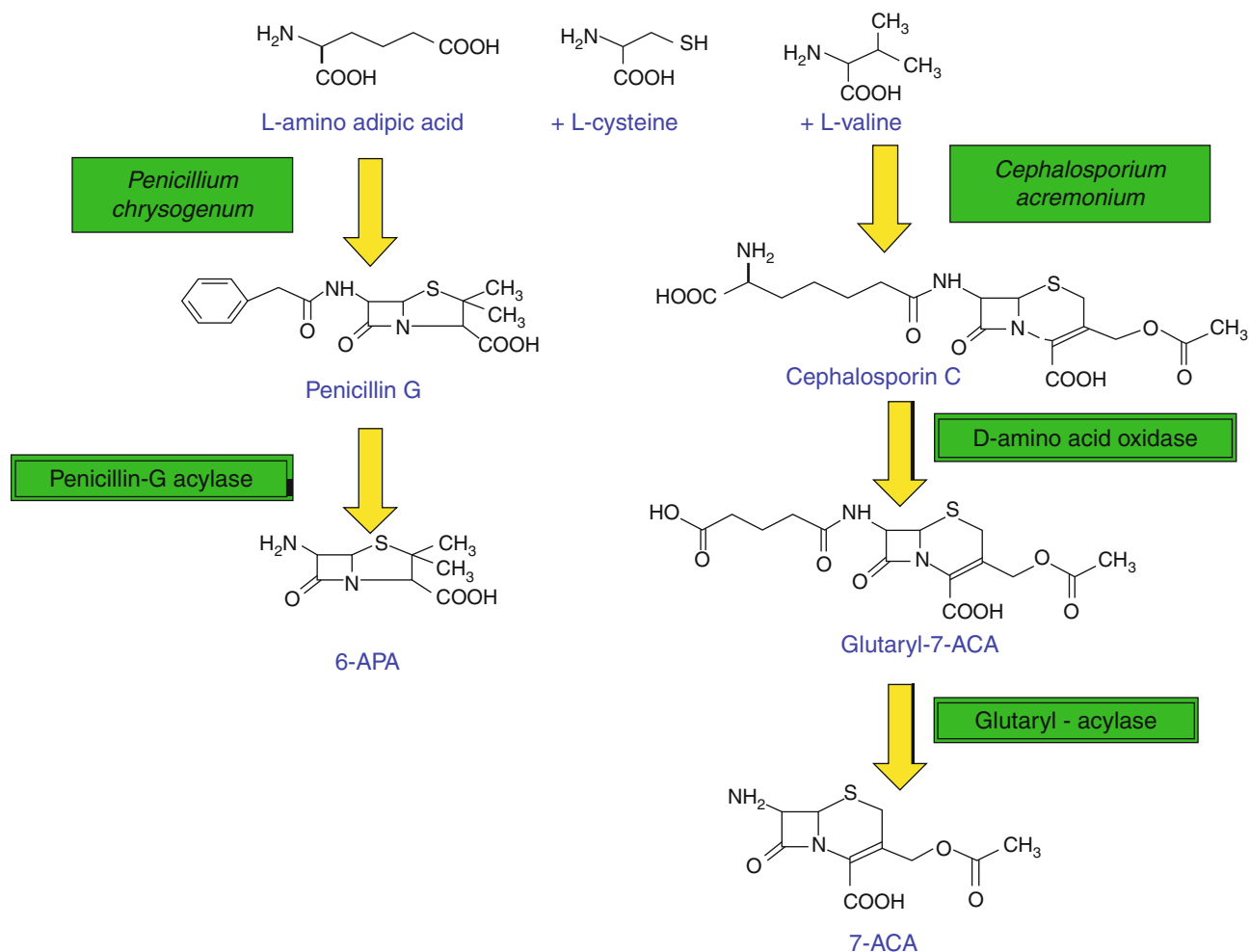

Fig. 6.6

The role of β -lactam acylases in the manufacturing of semisynthetic cephalosporins and penicillins. In the left pathway, the production of 6-amino penicillanic acid (6-APA) from the fermentation product penicillin G is shown. In the right pathway, the production of 7-aminocephalosporanic acid (7-ACA) from the fermentation product cephalosporin-C is depicted

cephalosporin-C, requires the cleavage of aminoadipyl, an aliphatic side chain, from the β -lactam nucleus. Since a one-step enzymatic deacylation (Aramori et al. 1991a) was not feasible, a combination of two enzyme-mediated reactions has been introduced to produce 7-aminocephalosporanic acid (ACA). In this process, D-amino acid oxidase and a glutaryl acylase perform an enzymatic deacylation of cephalosporin-C (see Fig. 6.6, right column). This glutaryl acylase (EC 3.5.1.-) can be obtained from several *Pseudomonas* species (Shibuya et al. 1981; Matsuda et al. 1987; Aramori et al. 1991a; Ishiye and Niwa 1992; Ishii et al. 1994; Li et al. 1998) or from a *Bacillus* species (Aramori et al. 1991b). Research toward a one-step cephalosporin-C-deacylating enzyme so far has been unsuccessful.

A third important intermediate, 7-aminodesacetoxycephalosporanic acid (7-ADCA), is produced from penicillin G by an expensive chemical ring expansion reaction. Subsequent deacylation of cephalosporin G can be achieved enzymatically by a

penicillin G acylase such as the enzyme from *Alcaligenes faecalis*; (Fig. 6.7, left column). The latest development in the field is the use of a genetically modified *Penicillium chrysogenum* equipped with an expandase gene from *Streptomyces clavuligerus* to produce adipyl-7-ADCA upon fermentation with adipate feed (Crawford et al. 1995, Fig. 6.7, right column). Deacylation of adipyl-7-ADCA cannot be done with penicillin acylases but requires an enzyme with affinity for the adipate side chain (Schroen et al. 2000; Xie et al. 2001). Some of the aforementioned glutaryl acylase enzymes have a low activity on this substrate. Recently by directed evolution, several mutants of *Pseudomonas* SY-77 acylase (EC 3.5.1) with a high activity on adipyl-7-ADCA have been isolated (Otten et al. 2002; Sio et al. 2002; Fig. 6.7).

Semisynthetic cephalosporins and penicillins are industrially produced from intermediates depicted in Figs. 6.6 and 6.7. As β -lactam acylases are hydrolytic enzymes, in theory the reaction can be reversed under conditions of low water

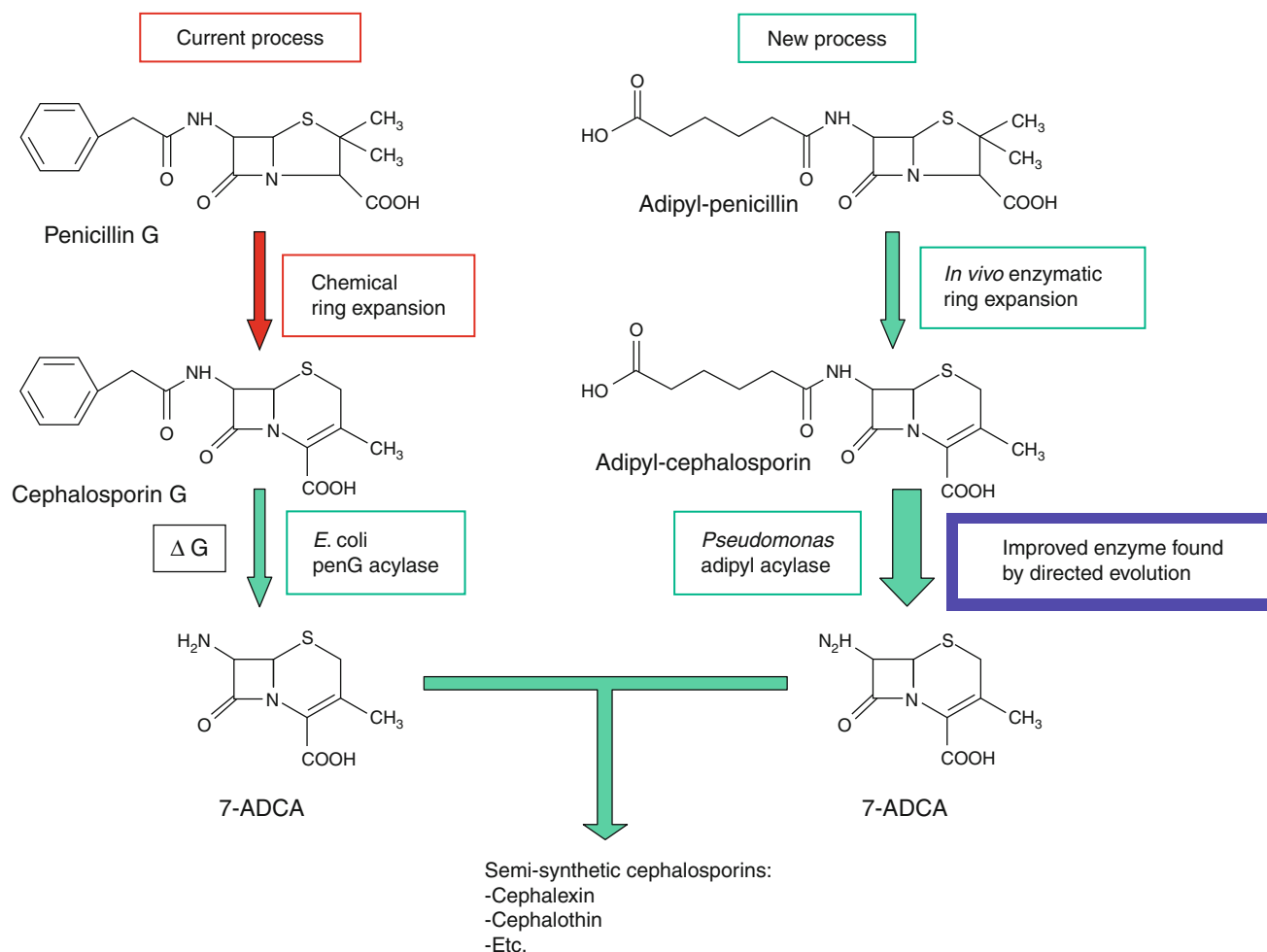

■ Fig. 6.7

In the left panel, the classical process for obtaining 7-ADCA is shown. A novel biosynthetic pathway for adipyl-cephalosporin using *Penicillium* is depicted in the right column. The final conversion toward 7-ADCA is done with an adipyl-cephalosporin acylase. Using directed evolution, the glutaryl acylase of *Pseudomonas SY77* has been converted into an adipyl acylase (Otten et al. 2002; Sio et al. 2002)

concentration. Precisely this property of β -lactam acylases is being used for the selective coupling of specific side chains to form pharmaceutically valuable β -lactams such as ampicillin, cephalexin (Boesten and Moody 1995), and loracarbef (Koeller and Wong 2001). Directed evolution will undoubtedly result in the isolation of variants with novel synthetic properties (Alkema et al. 2000).

Other Amidases

Aspartame is a dipeptide with an immense sweet taste. The synthesis of this low-calorie sweetener is performed with the neutral protease (EC 3.4.24.27) from *Bacillus thermoproteolyticus* also known as “thermolysin.” Applied as a reversal of the hydrolytic reaction, the enzyme shows a remarkable specificity in the coupling of N-protected-L-aspartic acid and D/L phenylalanine methyl ester. Owing its extreme thermostability, the enzyme is very stable in the high solvent conditions used for

the reaction. As an alternative to thermolysin, a highly stable variant of *Bacillus stearothermophilus* neutral protease obtained by protein engineering is now available (Mansfeld et al. 1997; Van den Burg et al. 1998).

Amidases are also applied for the chiral resolution of racemic amino acid amides to allow the biocatalytic synthesis of nonnatural L-amino acids, which are important building blocks for pharmaceuticals. An amidase (EC 3.5.1.4) from *Pseudomonas putida* has been developed for the kinetic resolution of a wide range of amino acid amides (Schmid et al. 2001).

Lipases and Esterases

Lipases from *Pseudomonas aeruginosa*, *Pseudomonas cepacia*, and *Pseudomonas fluorescens* (EC 3.1.1.3) are being used for a large number of different synthetic reactions in organic chemistry with special emphasis on kinetic resolution of chiral compounds (Coffen 1997). As lipases are active in organic solvents,

not only hydrolytic but also transesterification reactions can be performed. For racemic alcohols, this may be an enantioselective transformation with acyl donors such as vinyl esters, anhydrides, or diketenes (Koeller and Wong 2001; Schmid et al. 2001). Using this process, enantiomerically pure alcohols are produced on a several hundred ton scale by Badische Anilin und Soda Fabriken (BASF). *Pseudomonas* lipase can also react with amines as nucleophiles, allowing the resolution of optically active amines such as *S*-methoxyisopropylamine, an important building block for the herbicide "FrontierX2."

The enzymatic activity of lipases is very comparable to that of esterases, with the main difference being the chain length and hydrophobicity of the acid moiety of the substrate. Therefore in fine chemical applications, lipases and esterases are being used as alternatives for several conversions. For instance, for the kinetic resolution of 2-arylpionic acids such as naproxen and ibuprofen, both a lipase and an esterase have been found that can perform a stereoselective hydrolysis yielding the pharmaceutically preferred enantiomer *S*-naproxen (Bertola et al. 1992; Hedstrom et al. 1993). High activity and ease of production have made the carboxylesterase from *Bacillus subtilis* Thai I-8 the prime choice of industry (Quax and Broekhuizen 1994).

The markets for fine chemicals that can be made from esters are very important and diverse. Thus, the ability to perform ester hydrolysis or esterification reactions in a manner that ensures high specificity and high stereoselectivity is of great importance. Therefore, the use of genomics information to search for new esterases is of great interest (Robertson et al. 1999; Droge et al. 2001).

Areas of Research

Feed

Animal feed is mainly composed of polymeric structures that have to be digested in the gut. Any pretreatment of the agricultural stock may lead to an improved digestibility and hence yield of feedstuffs. It is therefore no surprise that most of the hydrolytic enzymes including the pancreatic extracts used as the first enzyme preparation in the 1920s have been tested in one way or another for the processing of animal feed. Only after an increased understanding of the digestive physiology did realistic applications come within reach. The examples described below are the result of expert advice and evaluation of feed industry experiences.

Phytases

Phosphorus is an important component of feed, as it is crucial for bone and skeleton formation. About 70 % of phosphorus in vegetable feed ingredients is present in the form of phytate, an inositol-bound organic form of phosphorus that has a low bioavailability in monogastric animals. For this reason, the diet for monogastric animals like pigs and chickens is supplemented

with significant amounts of inorganic phosphate that causes eutrophication in regions of the world with a dense monogastric animal population, such as the Netherlands. The addition of microbial phytases (EC 3.1.3.26) has resulted in a doubling of the bioavailability of phytate, obviating the need for addition of inorganic phosphate (Simons et al. 1990). This has led to lowering phosphate in manure to unprecedented levels in the Netherlands and to phosphate pollution reductions that are more significant than the reductions from the detergent phosphate ban in the mid-1970s.

Phytase from fungi has been shown to be extremely compatible with the low pH conditions of the animal gastric tract (Jongbloed et al. 1992), but also phytases from bacteria, such as *Bacillus subtilis*, are being developed for use as a feed additive (Kerovuo et al. 2000; Park et al. 1999; Kerovuo and Tynkkynen 2000).

Xylanases

Pentosans present in wheat and rye diets are often poorly metabolized. Especially arabinoxylans negatively influence the digestion and absorption of nutrients in the foregut of animals. When a xylanase (EC 3.2.1.8) treated arabinoxylan fraction was used, the nutritional parameters were similar to those when an arabinose and xylan monomeric mixture was used, indicating that xylanases are a valuable feed additive. Especially sought are enzymes with endo-1,4- β -xylanase activity that are stable in the digestive tract of poultry (Mondou et al. 1986).

Paper and Pulp

In the pulp and paper manufacturing process, elemental chlorine is applied for the bleaching of the pulp. As a by-product of this process, toxic chlorinated phenols as well as polychlorinated biphenyls are formed. Next to alternative bleaching chemicals such as ozone, the use of enzymes has gained more interest. Especially the removal of residual lignin results in a lower required amount of bleaching chemicals, allowing the replacement of elementary chlorine by the less polluting chlorine dioxide. The removal of lignin can be facilitated by a pretreatment of the pulp with xylanases or by laccases. This xylanase pretreatment cleaves the hemicellulose fraction that links the lignin to the cellulose. The laccase treatment results in a direct oxidative degradation of the lignin. The search for sufficiently active laccase systems is still in its infancy, but xylanases have been developed for commercial use.

The pulping process in a paper mill is performed at temperatures of 65–80 °C at pH 9–12. Xylanases (EC 3.2.1.32; endo-1,3- β -xylanase) from some thermophilic bacilli were found to be compliant with these conditions (Gat et al. 1994), and the xylanase from *Bacillus stearothermophilus* T6 was developed and tested on a large scale (Lundgren et al. 1994). This enzyme shows activity at high temperature (60–70 °C) and

high pH (7–9). The enzyme can be expressed and purified in high yields from *Bacillus subtilis* (Lapidot et al. 1996). The search for even more thermostable and more alkaline-stable xylanases has been targeted toward extremophiles (Saul et al. 1995; Outtrup et al. 1998).

General Expression Hosts

Bacteria are attractive for large-scale manufacturing of commercially relevant proteins owing to their fast growth rate and their high protein synthesis capacity. Enhanced levels of gene expression, however, often result in the intracellular accumulation of inactive protein aggregates also known as inclusion bodies. For most enzyme manufacturing processes, the recovery of active protein from these aggregates is uneconomical. The only enzyme process that has been in use for many years has been the manufacturing of bovine chymosin (rennin), with the Gram-negative bacterium *E. coli* as a host (Nishimori et al. 1981; Emtage et al. 1983).

Export of overexpressed heterologous enzymes from the cytoplasm has been explored as a solution to prevent inclusion body formation and to produce functional proteins in an easily recoverable form. With the identification of some periplasmic chaperone and foldase functions in Gram-negative bacteria, the concept of using the periplasm as a “construction compartment” in which chaperones aid the folding and functional assembly of proteins has come within reach. The ultimate goal from the viewpoint of industrial scale recovery—accumulation of proteins on a gram per liter scale in the extracellular medium—requires however the passage through two membranes. Recently described have been some nonpathogenic species such as *Pseudomonas alcaligenes* that have the capacity to secrete commercially important enzymes (lipases, proteases, cellulases, and phospholipases) in significant amounts into the extracellular medium (Gerritse et al. 1998a). The outer membrane secretion machinery is crucial for the export of proteins from the periplasm. At high expression levels, the outer membrane can become a barrier as exemplified by the effect on *Pseudomonas alcaligenes* lipase overexpression of selecting the *Xcp* gene cluster using the phenotype enhancement method (Gerritse et al. 1998b). The *xcp* gene cluster encodes the type II secretion pathway in Gram-negative bacteria, also referred to as the main terminal branch (MTB) of the general secretion pathway (GSP). Proteins secreted via the GSP pass the cell envelope in two separate steps. First, they are translocated across the inner membrane into the periplasm, a process mediated by the Sec machinery. Subsequently, the periplasmic intermediates are translocated across the outer membrane as fully folded proteins (► Fig. 6.5). Several nonspecific chaperones function in the periplasm of *E. coli*. The peptidyl-prolyl-*cis-trans*-isomerases (PPI) catalyze the *cis-trans* isomerization of X-proline peptide bonds, which was found to be rate limiting upon high-level production of functional single chain Fv (scFV) fragments in the periplasm of *E. coli* (Jager and Pluckthun 1997). A second class of nonspecific chaperones, the thiol-disulfide

oxidoreductases (Dsb) that catalyze the formation of disulfide bonds, has been shown to play a crucial role in the formation of disulfide bonds in heterologous proteins expressed in *E. coli* (Joly and Swartz 1997; Joly et al. 1998). Recently homologues of *dsb* genes have been found in *Pseudomonas aeruginosa* to be involved lipase folding (Reetz and Jaeger 1998).

In addition to nonspecific chaperones, the folding of a variety of extracellular proteins requires the action of specific chaperones. For example, the correct folding of lipases is mediated by the lipase-specific foldases (Lif). It has been shown that folding of the lipase of *Pseudomonas aeruginosa*, when expressed in *E. coli*, is dependent on the coexpression of the *Pseudomonas aeruginosa lif* gene (El-Khattabi et al. 1999). Interestingly, it was found that the amount of Lif can become limiting in an industrial *Pseudomonas alcaligenes* strain upon overexpression of the endogenous lipase gene (Gerritse et al. 1998a).

Bacillus species have always been the paradigm hosts for the production of bacterial enzymes, and around 50 % of the total worldwide enzyme production is by bacilli. Nevertheless, the protein secretion machinery of *Bacillus* has certain limitations, and in a systematic analysis, members of the European *Bacillus* Secretion Group (EBSG) over the past years have identified bottlenecks in the secretion pathway of *Bacillus subtilis* that relate to different stages in the secretion process. Different proteins can run into different limiting factors (Bolhuis et al. 1999). During transport over the membrane, signal peptidases can become limiting factors in pre-protein processing. For example, overproduction of signal peptidase was shown to be beneficial for the secretion of heterologous β -lactamase from *Bacillus subtilis* (Van Dijl et al. 1992). Alternatively, signal peptidases can interfere with efficient pre-protein processing under conditions of high-level overproduction of secretory proteins. This is illustrated by the observation that the disruption of the *sipS* gene, encoding one of the five signal peptidases of *Bacillus subtilis*, resulted in highly increased rates of processing of an α -amylase precursor (Tjalsma et al. 1997).

Finally, late stages in the secretion process, including the folding of mature proteins and cell wall passage, can become secretion bottlenecks. It was found that the lipoprotein PrsA becomes limiting under conditions of high-level secretion of α -amylases, as it is required for the folding into a protease-resistant conformation upon translocation (Kontinen and Sarvas 1993). In another experiment, it was found that the cell wall, which is relatively thick (10–50 nm) and contains a high concentration of immobilized negative charge (e.g., teichoic or teichuronic acids), can act as a barrier in translocation (Saunders and Guyer 1986; Stephenson et al. 1998). Thus, proteins with a net positive charge might be retained in the wall. Furthermore, it was shown that the wall-bound serine protease CWBP52, encoded by the *wprA* gene, can degrade slowly folding enzymes at the site of pre-protein translocation. Hence, CWBP52 depletion has resulted in an increased yield of secreted α -amylase (Stephenson and Harwood 1998).

More successful approaches to remove bottlenecks in the production of proteins from *Bacillus* involve the elimination of detrimental factors, such as extracellular proteases. In a stepwise

approach, strains with an increasing number of protease gene deletions have been constructed, resulting in a sevenfold protease-negative strain that shows significant higher yields of susceptible bacterial enzymes (Ye et al. 1999).

Patents and Regulatory Systems

Regulations and Enzymes

Bacterial enzymes for food applications must comply with the regulations put forward by the United States Food and Drug Administration (FDA) or comparable bodies in other countries. Most enzymes are considered as food processing aids and usually do not end up in the final consumer end product. Nevertheless, all products undergo a strict testing program including toxicity and efficacy testing. Finally, the industrial production process has to comply with the regulations stipulated by the Environmental Protection Agency (EPA). These documents may be accessed through Office of Pollution Prevention and Toxics' Biotechnology Program homepage at the EPA homepage (<http://www.epa.gov/opptintr/biotech/>). Alternatively, the documents are available from the (<http://www.epa.gov/fedrgstr/>) at the Environmental Sub Set entry for this document under "Regulations."

The industrial and household enzyme products not used for food applications must comply with the regulations of the EPA and general product safety regulations. Especially with respect to preventing allergenicity, there are strict specifications for formulating enzymes and preventing dust formation. The production host strains must be nontoxic and preferably with a record of safe use. Most of the enzyme products have Generally Recognized as Safe (GRAS) status.

Patents and Taxonomy

Purified enzyme products can be covered by a broad substance patent claim as long as the disclosure complies with the three elements of a patent application: the substance should be novel, the disclosure should involve an inventive step, and the substance should have a use. The aspect of novelty can be readily checked since the amino acid sequence of a newly described enzyme can be easily compared to a protein or DNA database. As the number of described amino acid and DNA sequences has exploded in the past years and since patent examiners tend to use the criterion of 70 % amino acid sequence identity to specify homologous enzymes, it is clear that broad substance patent claims will be difficult to obtain in future. Rather, patent protection will be sought more for specific methods and applications of certain enzymes. Enzymes that have been obtained by protein engineering or directed evolution represent a special group of patent claims. As the sequence identity to existing enzymes will generally be very high (>99 %), the variant will need to have a property that distinguishes it from wild-type enzymes to become patentable. Patent claims

in those cases have mostly been restricted to the specific examples shown in the description.

With the granting of patent claims on living organisms (Chakrabarty 1981), a new dimension was added to the intellectual property protection. Patent claims on the bacteria themselves were initially rejected because living things were not considered patentable. Finally, the United States Supreme Court reversed the initial decision, making the argument that a genetically engineered microorganism is not a product of nature but rather a product of a person's work and is thus patentable under the United States law. This decision has added a new element to the patenting of bacterial enzymes and the host cells producing them. Now also the bacterial strains as isolated from natural sources could be patented (Collins et al. 1998a, b; Outtrup et al. 1998). A detailed description in the form of a correct taxonomic determination of the strain is now essential to obtain good patent protection. This has led to the development of modern tools for the description of claimed species, such as the 16 S RNA identification.

Prospects

Extremophiles

Enzymes isolated from microorganisms living under harsh conditions are adapted to those extreme conditions. For example, an amylase and a protease that are fully stable and active at 95 °C have been isolated from *Pyrococcus furiosus*, a hyperthermophile living in a 90 °C hot spring (Brown et al. 1990; Eggen et al. 1990). Especially the progress in research on archaea and the ability to culture these strains in the laboratory have generated a lot of enthusiasm for household and industrial uses of enzymes from extremophiles. As the growth conditions for these extremophiles are difficult to create on an industrial scale, the goal is to express the genetic material encoding these enzymes in mesophilic hosts. Numerous novel genes encoding thermostable (Koch et al. 1990; Hakamada et al. 2000), alkali stable (Shendye and Rao 1993; Kobayashi et al. 1995; Saeki et al. 2000), and acid stable (Tamuri et al. 1997) enzymes have been characterized in recent years. This can result in not only enzymes better suited to existing applications (such as detergents [alkaline] and starch [high temperature]) but also completely new applications such as the enzymatic bleaching of pulp, a process requiring both high temperature and very alkaline conditions. The yields in production of enzymes from extremophiles, however, are generally low because compatibility of these proteins with the folding and secretion machinery of mesophilic hosts is low. The impact of these novel enzymes on the household and industrial enzyme market therefore remains to be seen and "expressibility" must be considered when selecting extremophilic enzymes with desired properties (Van Solingen et al. 2001). The best results have been obtained with enzymes from extremophilic eubacterial origin, such as the thermostable xylanase (produced on a large scale for enzymatic pulp treatment) from *Bacillus stearothermophilus* (Lundgren et al. 1994). In research and diagnostic laboratories,

the thermostable DNA polymerases (such as the Taq polymerase from *Thermus aquaticus* and Pfu polymerase from *Pyrococcus furiosus*) have shown their tremendous value already (Peterson 1988; Picard et al. 1994). The diagnostic enzymes including the huge diversity of restriction enzymes and polymerases are, however, beyond the scope of this chapter.

Directed Evolution

In the past two decades, the technique of protein engineering has allowed investigators to create new enzymes and proteins. Interestingly, some of the most striking commercial successes have not been the result of rational design based on a 3D structure, but merely the payoff of smart combinations of random mutagenesis and screening. The power of this combination resides in the fact that many variants with subtle differences can be probed quickly. In practice, however, major weaknesses are still encountered, as most screening assays for enzymatic activity are rather limited in throughput. A major improvement can be made if a selection instead of a screening can be introduced. This combination of gene pool diversification and selection for function (collectively termed “directed evolution”) is now considered as one of the most successful protein engineering strategies. Two processes play a key role in evolution: mutation and selection. Gene mutation methods have been expanded enormously with the advent of the polymerase chain reaction (PCR) techniques (error prone PCR and PCR with spiked oligonucleotide primers and staggered extension process) and DNA shuffling (Cramer et al. 1997; Zhao et al. 1998; Matsumura et al. 1999). However, the selection for function is less obvious as the majority of industrial enzymes are secreted into the extracellular medium, which interferes with growth selection. Most of the newly described directed evolution studies have been on intracellular enzymes with in vivo selectable functions, such as β -lactamase, which can be selected for by increasing the antibiotic concentrations (Stemmer 1994). Attempts have been made to use display techniques involving coupling of the phenotype of an extracellular enzyme with the genotype. As demonstrated with the industrially important enzyme α -amylase from *Bacillus licheniformis*, it is possible to use phage display for the selection of enzymes with improved substrate binding properties (Verhaert et al. 2002). Binding to substrate transition state analogues has been used to select for enzymes with altered catalytic properties. Although binding of phages to transition state analogues is feasible, the use of this technique to select for industrially relevant catalytic properties remains to be established (Legendre et al. 2000). More success has been obtained with the compartmentalization of bacteria that are secreting mutant enzymes. By fixing the mutant bacterial cells in a solid matrix, the diffusion of the secreted mutant protease was delayed. This provides a way of coupling the phenotype to the genotype, inasmuch as the converted growth substrate remains in the same compartment as the bacterial cell (Tawfik and Griffiths 1998; Griffiths and Tawfik 2003). Finally, a novel dimension has been given to evolution techniques by the use of

genes isolated directly from soil samples (without culturing the donor organism). In a large experiment, genes encoding amylases were cloned directly from soil and identified by expression on starch plates, and the resulting genes have been “evolved” using DNA shuffling. This has resulted in a very thermostable α -amylase (Richardson et al. 2002). This shows that isolating enzyme encoding genes from extremophiles combined with directed evolution in the laboratory can be a path forward for enzyme engineering.

Acknowledgments

This chapter is a compilation of numerous collaborations that have allowed the author to develop insights and ideas in the bacterial enzyme field. Special thanks to all the colleagues and students who have contributed material and illustrations presented in this chapter. The sponsoring of EU under contracts BIO2-CT950119, BIO4-9-98-0249, QLK3-CT-1999-00413, QLTR-2001-00519, and of NWO/STW under contract GBI.4707 is highly acknowledged.

References

- Aehle W, Gerritse G, Lenting HB (1995) Lipases with improved surfactant resistance. Patent WO 95/30744
- Aiba S, Kitai K, Imanaka T (1983) Cloning and expression of thermostable alpha-amylase gene from *Bacillus stearothermophilus* in *Bacillus stearothermophilus* and *Bacillus subtilis*. Appl Environ Microbiol 46:1059–1065
- Albers E, Muller BW (1995) Cyclodextrin derivatives in pharmaceuticals. Crit Rev Ther Drug Carrier Syst 12:311–337
- Alkema WB, Hensgens CM, Kroezinga EH, De Vries E, Floris R, Van der Laan JM, Dijkstra BW, Janssen DB (2000) Characterization of the beta-lactam binding site of penicillin acylase of *Escherichia coli* by structural and site-directed mutagenesis studies. Protein Eng 13:857–863
- Aramori I, Fukagawa M, Tsumura M, Iwami M, Isogai T, Ono H, Ishitani Y, Kojo H, Kohsaka M, Ueda Y, Imanaka H (1991a) Cloning and nucleotide sequencing of new glutaryl 7-aca and cephalosporin c acylase genes from pseudomonas strains. J Ferment Bioeng 72(4):232–243
- Aramori I, Fukagawa M, Tsumura M, Iwami M, Ono H, Kojo H, Kohsaka M, Ueda Y, Imanaka H (1991b) Cloning and nucleotide sequencing of a novel 7 beta-(4-carboxybutanamido)cephalosporanic acid acylase gene of *Bacillus laterosporus* and its expression in *Escherichia coli* and *Bacillus subtilis*. J Bacteriol 173:7848–7855
- Balasingham K, Warburton D, Dunnill P, Lilly MD (1972) The isolation and kinetics of penicillin amidase from *Escherichia coli*. Biochim Biophys Acta 276:250–256
- Barbero JL, Buesa JM, Gonzalez De Buitrago G, Mendez E, Perez-Aranda A, Garcia JL (1986) Complete nucleotide sequence of penicillin acylase gene from *Kluyvera citrophila*. Gene 49:69–80
- Bertola MA, Quax WJ, Robertson BW, Marx AF, van der Laken CJ (1992) Microbial esterases and process for the preparation of 2-arylpropionic acids. Patent EP 233656-B
- Betzel C, Wilson KS, Branner S (1988) Crystallization and preliminary X-ray diffraction studies of an alkaline protease from *Bacillus lentus*. J Mol Biol 204:803–804
- Boesten WHJ, Moody HM (1995) Process for the enzymatic preparation of a beta-lactam derivative. Patent WO 9503420
- Bolhuis A, Tjalsma H, Smith HE, De Jong A, Meima R, Venema G, Bron S, van Dijk JM (1999) Evaluation of bottlenecks in the late stages of protein secretion in *Bacillus subtilis*. Appl Environ Microbiol 65:2934–2941

- Brown SH, Costantino HR, Kelly RM (1990) Characterization of amylolytic enzyme activities associated with the hyperthermophilic archaeobacterium *Pyrococcus furiosus*. *Appl Environ Microbiol* 56:1985–1991
- Bruggink A, Roos EC, Devroom E (1998) Penicillin acylase in the industrial production of beta-lactam antibiotics. *Org Process Res Dev* 2:128–133
- Bruns W, Hoppe J, Tsai H, Bruning HJ, Maywald F, Collins J, Mayer H (1985) Structure of the penicillin acylase gene from *Escherichia coli*: a periplasmic enzyme that undergoes multiple proteolytic processing. *J Mol Appl Genet* 3(1):36–44
- Buleon A, Colonna P, Planchot V, Ball S (1998) Starch granules: structure and biosynthesis. *Int J Biol Macromol* 23:85–112
- Callens M, Kersters-Hilderson H, Vangrype W, De Bruyne CK (1988) D-xylose isomerase from streptomycetes violaceoruber: structural and catalytic roles of bivalent metal ions. *Enzyme Microb Technol* 10:695–700
- Chakrabarty AM (1981) Microorganisms having multiple compatible degradative energy-generating plasmids and preparation thereof. US Patent 4,259,444
- Chandra AK, Medda S, Bhadra AK (1980) Production of extracellular thermostable alpha-amylase by *Bacillus licheniformis*. *J Ferment Technol* 58:1–10
- Chen W-P (1980) Glucose isomerase [review]. *Proc Biochem* 15:36–41
- Christiansen T, Christensen B, Nielsen J (2002) Metabolic network analysis of *Bacillus clausii* on minimal and Semirich medium using (13)C-labeled glucose. *Metab Eng* 4:159–169
- Coffen DL (1997) Enzyme-catalyzed reactions. In: Ahuja SE (ed) Chiral separations: applications and technology. American Chemical Society, Washington, DC, pp 59–91
- Collins NC, Grant WD, Jones BE (1998a) Gram-negative alkaliphilic microorganisms. US Patent 5,733,767
- Collins NC, Grant WD, Jones BE (1998b) Gram-positive alkaliphilic microorganisms. US Patent 5,707,851
- Cox M, Gerritse G, Dankmeyer L, Quax WJ (2001) Characterization of the promoter and upstream activating sequence from the *Pseudomonas alcaligenes* lipase gene. *J Biotechnol* 86:9–17
- Cramer A, Dawes G, Rodriguez E Jr, Silver S, Stemmer WP (1997) Molecular evolution of an arsenate detoxification pathway by DNA shuffling. *Nat Biotechnol* 15:436–438
- Crawford L, Stepan AM, Mcada PC, Rambosk JA, Conder MJ, Vinci VA, Reeves CD (1995) Production of cephalosporin intermediates by feeding adipic acid to recombinant *Penicillium chrysogenum* strains expressing ring expansion activity. *Biotechnology (NY)* 13:58–62
- Drenth J, Hol WGJ, Jansonius JN, Koekoek R (1972) Subtilisin novo: The three-dimensional structure and its comparison with subtilisin Bpn. *Eur J Biochem* 26:177–181
- Droge MJ, Bos R, Quax WJ (2001) Paralogous gene analysis reveals a highly enantioselective 1,2-o-isopropylidene-glycerol caprylate esterase of *Bacillus subtilis*. *Eur J Biochem* 268:3332–3338
- Drummond RJ, Bloch W, Matthews BW, Toy PL, Nicholson HH (1989) Prokaryotic xylose isomerase muteins and method to increase protein stability. Patent WO 89/01520
- Edman M, Jarhede T, Sjoström M, Wieslander A (1999) Different sequence patterns in signal peptides from mycoplasmas, other Gram-positive bacteria, and *Escherichia coli*: a multivariate data analysis. *Prot Struct Funct Genet* 35:195–205
- Eggen R, Geerling A, Watts J, Devos WM (1990) Characterization of pyrolysin, a hyperthermoactive serine protease from the archaeobacterium *Pyrococcus furiosus*. *FEMS Microbiol Lett* 71:17–20
- El-Khattabi M, Ockhuijsen C, Bitter W, Jaeger KE, Tommassen J (1999) Specificity of the lipase-specific foldases of gram-negative bacteria and the role of the membrane anchor. *Mol Gen Genet* 261:770–776
- Emtage JS, Angal S, Doel MT, Harris TJR, Lowe B, Jenkins PA, Lilley G (1983) Synthesis of calf prothymosin (prorennin) in *Escherichia coli* (synthetic oligonucleotide/gene expression/industrial enzyme). *Proc Natl Acad Sci USA* 80:3671–3675
- Estell DA, Graycar TP, Wells JA (1985) Engineering an enzyme by site-directed mutagenesis to be resistant to chemical oxidation. *J Biol Chem* 260:6518–6521
- Farber GK, Petsko GA, Ringe D (1987) The 3.0 Å crystal structure of xylose isomerase from *Streptomyces olivochromogenes*. *Protein Eng* 1:459–466
- Filloux A, Michel G, Bally M (1998) GSP-dependent protein secretion in Gram-negative bacteria: the Xcp system of *Pseudomonas aeruginosa*. *FEMS Microbiol Rev* 22:177–198
- Gat O, Lapidot A, Alchanati I, Regueros C, Shoham Y (1994) Cloning and dna sequence of the gene coding for *Bacillus stearothermophilus* T-6 xylanase. *Appl Environ Microbiol* 60:1889–1896
- Genencor Cleaning Enzymes Product List (2001) Genencor cleaning enzymes product list. Genencor International, Rochester
- Gerritse G, Hommes RW, Quax WJ (1998a) Development of a lipase fermentation process that uses a recombinant *Pseudomonas alcaligenes* strain. *Appl Environ Microbiol* 64:2644–2651
- Gerritse G, Ure R, Bizoullier F, Quax WJ (1998b) The phenotype enhancement method identifies the Xcp outer membrane secretion machinery from *Pseudomonas alcaligenes* as a bottleneck for lipase production. *J Biotechnol* 64:23–38
- Gray GL, Mainzer SE, Rey MW, Lamsa MH, Kindle KL, Carmona C, Requadt C (1986) Structural genes encoding the thermophilic alpha-amylases of *Bacillus stearothermophilus* and *Bacillus licheniformis*. *J Bacteriol* 166:635–643
- Gray GL, Power SD, Poulouse AJ (1995) Lipase from *Pseudomonas Mendocina* having cutinase activity. US Patent 5,389,536
- Griffiths AD, Tawfik DS (2003) Directed evolution of an extremely fast phosphotriesterase by in vitro compartmentalization. *EMBO J* 22:24–35
- Gusakov AV, Sinityn AP, Berlin AG, Markov AV, Ankudimova NV (2000) Surface hydrophobic amino acid residues in cellulase molecules as a structural factor responsible for their high denim-washing performance. *Enzyme Microb Technol* 27:664–671
- Hakamada Y, Hatada Y, Koike K, Yoshimatsu T, Kawai S, Kobayashi T, Ito S (2000) Deduced amino acid sequence and possible catalytic residues of a thermostable, alkaline cellulase from an alkaliphilic bacillus strain. *Biosci Biotechnol Biochem* 64:2281–2289
- Hedstrom G, Backlund M, Slotte JP (1993) Enantioselective synthesis of ibuprofen esters in Aot iso-octane microemulsions by *Candida cylindracea* lipase. *Biotechnol Bioeng* 42:618–624
- Henrick K, Blow DM, Carrell HL, Glusker JP (1987) Comparison of backbone structures of glucose isomerase from streptomyces and arthrobacter. *Protein Eng* 1:467–469
- Hesslink PGM, van Vliet S, De Vries H, Witholt B (1989) Optimization of steroid side chain cleavage by *Mycobacterium* sp. in the presence of cyclodextrins. *Enzyme Microb Technol* 11:398–404
- Hofmeister J, Kurtz A, Borriss R, Knowles J (1986) The beta-glucanase gene from *Bacillus amyloliquefaciens* shows extensive homology with that of *Bacillus subtilis*. *Gene* 49:177–187
- Hofmann BE, Bender H, Schulz GE (1989) Three-dimensional structure of cyclodextrin glycosyltransferase from *Bacillus circulans* at 3.4 Å resolution. *J Mol Biol* 209:793–800
- Irwin D, Shin DH, Zhang HL, Barr BK, Sakon J, Karplus PA, Wilson DB (1998) Roles of the catalytic domain and two cellulose binding domains of *Thermomonospora fusca* E4 in cellulose hydrolysis. *J Bacteriol* 180:1709–1714
- Ishii Y, Saito Y, Fujimura T, Isogai T, Kojo H, Yamashita M, Niwa M, Kohsaka M (1994) A novel 7-beta-(4-carboxybutanamido)-cephalosporanic acid acylase isolated from *Pseudomonas* strain C427 and its high-level production in *Escherichia coli*. *J Ferment Bioeng* 77:591–597
- Ishiy M, Niwa M (1992) Nucleotide sequence and expression in *Escherichia coli* of the cephalosporin acylase gene of a *Pseudomonas* strain. *Biochim Biophys Acta* 1132:233–239
- Jacobs M, Eliasson M, Uhlen M, Flock JI (1985) Cloning, sequencing and expression of subtilisin Carlsberg from *Bacillus licheniformis*. *Nucleic Acids Res* 13:8913–8927
- Jager M, Pluckthun A (1997) The rate-limiting steps for the folding of an antibody ScFv fragment. *FEBS Lett* 418:106–110
- Jeong ST, Kim HK, Kim SJ, Chi SW, Pan JG, Oh TK, Ryu SE (2002) Novel zinc-binding center and a temperature switch in the *Bacillus stearothermophilus* L1 lipase. *J Biol Chem* 277:17041–17047

- Joly JC, Swartz JR (1997) In vitro and in vivo redox states of the *Escherichia coli* periplasmic oxidoreductases Dsba and Dsbc. *Biochemistry* 36:10067–10072
- Joly JC, Leung WS, Swartz JR (1998) Overexpression of *Escherichia coli* oxidoreductases increases recombinant insulin-like growth factor-I accumulation. *Proc Natl Acad Sci USA* 95:2773–2777
- Jones B, Quax W (1998) Alzheimer tau test and detergent cellulase made by genetic engineering [no. 9 in a series of articles to promote a better understanding of the use of genetic engineering]. *J Biotechnol* 66:229–233
- Jones BE, Grant WD, Duckworth AW, Owenson GG (1998) Microbial diversity of soda lakes. *Extremophiles* 2:191–200
- Jongbloed AW, Mroz Z, Kemme PA (1992) The effect of supplementary *Aspergillus niger* phytase in diets for pigs on concentration and apparent digestibility of dry matter, total phosphorus and phytic acid in different sections of the alimentary tract. *J Anim Sci* 70:1168
- Jorgensen ST, Jorgensen PL (1993) A process for expressing genes in *Bacillus Licheniformis*. Patent WO 93/10248
- Jorgensen OB, Karlsen LG, Nielsen NB, Pedersen S, Rugh S (1988) A new immobilized glucose isomerase with high productivity produced by a strain of *Streptomyces murinus*. *Starch/Stärke* 40:307–313
- Jung ED, Lao G, Irwin D, Barr BK, Benjamin A, Wilson DB (1993) DNA sequences and expression in *Streptomyces lividans* of an exoglucanase gene and an endoglucanase gene from *Thermomonospora fusca*. *Appl Environ Microbiol* 59:3032–3043
- Kelly AP, Diderichsen B, Jorgensen S, McConnell DJ (1994) Molecular genetic analysis of the pullulanase b gene of *Bacillus acidopullulyticus*. *FEMS Microbiol Lett* 115:97–105
- Kerovuo J, Tynkkynen S (2000) Expression of *Bacillus subtilis* phytase in *Lactobacillus plantarum* 755. *Lett Appl Microbiol* 30:325–329
- Kerovuo J, Rouvinen J, Hatzack F (2000) Analysis of myo-inositol hexakisphosphate hydrolysis by *bacillus phytase*: indication of a novel reaction mechanism. *Biochem J* 352:623–628
- Kitahata S, Taniguchi M, Beltran SD, Sugimoto T, Okada S (1983) Purification and some properties of cyclodextrinase from *Bacillus coagulans*. *Agric Biol Chem* 47:1441–1447
- Knowles J, Lehtovaara P, Penttila M, Teeri T, Harkki A, Salovuori I (1987) The cellulase genes of trichoderma. *Antonie Van Leeuwenhoek* 53:335–341
- Kobayashi T, Hakamada Y, Adachi S, Hitomi J, Yoshimatsu T, Koike K, Kawai S, Ito S (1995) Purification and properties of an alkaline protease from alkalophilic *Bacillus* sp. KSM-K16. *Appl Microbiol Biotechnol* 43:473–481
- Koch R, Zabłowski P, Spreinat A, Antranikian G (1990) Extremely thermostable amyolytic enzyme from the archaeobacterium *Pyrococcus furiosus*. *FEMS Microbiol Lett* 71:21–26
- Koeller KM, Wong CH (2001) Enzymes for chemical synthesis. *Nature* 409:232–240
- Kontinen VP, Sarvas M (1993) The PrsA lipoprotein is essential for protein secretion in *Bacillus subtilis* and sets a limit for high-level secretion. *Mol Microbiol* 8:727–737
- Kosaric N, Wiczorek A, Cosentino GP, Magee RJ, Prenosil JE (1983) Ethanol fermentation. *Biotechnology* 3:258–385
- Kreft J, Berger H, Haertlein M, Mueller G, Goebel G, Weidinger W (1983) Cloning and expression in *E. coli* and *Bacillus subtilis* of the hemolysin determinant from *Bacillus cereus*. *J Bacteriol* 155:681–689
- Lapidot A, Mechaly A, Shoham Y (1996) Overexpression and single-step purification of a thermostable xylanase from *Bacillus stearothermophilus* T-6. *J Biotechnol* 51:259–264
- Legendre D, Laraki N, Graslund T, Bjornvad ME, Bouchet M, Nygren PA, Borchert TV, Fastrez J (2000) Display of active subtilisin 309 on phage: analysis of parameters influencing the selection of subtilisin variants with changed substrate specificity from libraries using phosphonylating inhibitors. *J Mol Biol* 296:87–102
- Li Y, Jiang W, Yang Y, Zhao G, Wang E (1998) Overproduction and purification of glutaryl 7-amino cephalosporanic acid acylase Protein. *Protein Expr Purif* 12:233–238
- Lin W, Lineback DR (1990) Changes in carbohydrate fractions in enzyme-supplemented bread and the potential relationship to staling. *Starch/Stärke* 42:385–394
- Luiten RGM, Quax WJ, Schuurhuizen PW, Mrabet N (1990) Novel glucose isomerase enzymes and their use. Patent EP 0351029-A
- Lundgren KR, Berkqvist L, Hogman S, Joves H, Eriksson G, Bartfai T, van der Laan J, Rosenberg E, Shoham Y (1994) Tcf mill trial on softwood pulp with korsnas thermostable and alkaline stable xylanase T6. *FEMS Microbiol Rev* 13:365–368
- Lyons TP (1982) Proteinase enzymes relevant to the baking industry. *Biochem Soc Trans* 10:287–290
- Mansfeld J, Vriend G, Dijkstra BW, Veltman OR, van Den BB, Venema G, Ulbrich-Hofmann R, Eijsink VG (1997) Extreme stabilization of a thermolysin-like protease by an engineered disulfide bond. *J Biol Chem* 272:11152–11156
- Matsuda A, Matsuyama K, Yamamoto K, Ichikawa S, Komatsu K (1987) Cloning and characterization of the genes for two distinct cephalosporin acylases from a *Pseudomonas* strain. *J Bacteriol* 169:5815–5820
- Matsumura I, Wallingford JB, Surana NK, Vize PD, Ellington AD (1999) Directed evolution of the surface chemistry of the reporter enzyme beta-glucuronidase. *Nat Biotechnol* 17:696–701
- McPhalen CA, James MNG (1988) Structural comparison of two serine proteinase-protein inhibitor complexes: Eglin-C-Subtilisin carlsberg and Ci-2-subtilisin novo. *Biochemistry* 27:6582–6598
- Mondou F, Sharek F, Morosoli R, Kluepfel D (1986) Cloning of the xylanase gene of *Streptomyces lividans*. *Gene* 49:323–329
- Nakajima R, Imanaka T, Aiba S (1986) Comparison of amino acid sequences of eleven different alpha-amylases. *Appl Microbiol Biotechnol* 23:355–360
- Nardini M, Lang DA, Liebeton K, Jaeger KE, Dijkstra BW (2000) Crystal structure of *Pseudomonas aeruginosa* lipase in the open conformation: the prototype for Family I.1 of bacterial lipases. *J Biol Chem* 275:31219–31225
- Nishimori K, Kawaguchi Y, Hidaka M, Uozumi T, Beppu T (1981) Communication: cloning in *Escherichia coli* of the structural gene of prorennin, the precursor of calf milk-clotting enzyme rennin. *J Biochem* 90:901–904
- Noble ME, Cleasby A, Johnson LN, Egmond MR, Frenken LG (1994) Analysis of the structure of *Pseudomonas glumae* lipase. *Protein Eng* 7:559–562
- Norris L, Norris F, Christiansen L, Fiil N (1983) Efficient site-directed mutagenesis by simultaneous use of two primers. *Nucleic Acids Res* 11:5103–5112
- Otten LG, Sio CF, Vrielink J, Cool RH, Quax WJ (2002) Altering the substrate specificity of cephalosporin acylase by directed evolution of the beta-subunit. *J Biol Chem* 277:42121–42127
- Outtrup H, Aunstrup K (1975) Production and application of a thermostable alpha-amylase from *Bacillus licheniformis*. In: *Proceedings of the First Intersectoral Congress of the Association of Microbiological Societies IAMS (IUMS)* 5:205–210
- Outtrup H, Dambmann C, Bisgaard-Frantzen H, Olsen AA, Schuelein M (1998) *Alkalophilic Bacillus* Sp. Ac13 and protease, xylanase, cellulase obtainable therefrom. US Patent 3,723,250
- Park SC, Choi YW, Oh TK (1999) Comparative enzymatic hydrolysis of phytate in various animal feedstuff with two different phytases. *J Vet Med Sci* 61:1257–1259
- Peterson MG (1988) DNA sequencing using Taq polymerase. *Nucleic Acids Res* 16:10915
- Picard V, Ersdalbadju E, Lu AQ, Bock SC (1994) A rapid and efficient one-tube PCR-based mutagenesis technique using PFU DNA polymerase. *Nucleic Acids Res* 22:2587–2591
- Quax WJ, Broekhuizen CP (1994) Development of a new bacillus carboxyl esterase for use in the resolution of chiral drugs. *Appl Microbiol Biotechnol* 41:425–431
- Quax WJ, Laroche Y, Vollebregt AWH, Stanssens P, Lauwereys M (1991a) Mutant microbial alpha-amylases with increased thermal, acid and/or alkaline stability. Patent WO 91/00353
- Quax WJ, Mrabet NT, Luiten RG, Schuurhuizen PW, Stanssens P, Lasters I (1991b) Enhancing the thermostability of glucose isomerase by protein engineering. *Nat Biotechnol* 9:738–742
- Quax WJ, Bonekamp AF, van Tilborg M (1993) Correct secretion of heterologous proteins from *Bacillus licheniformis*. In: Baltz HS (ed) *Industrial microorganisms: basic and applied molecular genetics*. ASM Press, Washington, DC, pp 143–150

- Reetz MT, Jaeger KE (1998) Overexpression, immobilization and biotechnological application of *Pseudomonas* lipases. *Chem Phys Lipids* 93:3–14
- Reilly PJ (1979) Starch hydrolysis with soluble and immobilized glucoamylase. *Appl Biochem Bioeng* 2:185–207
- Richardson TH, Tan X, Frey G, Callen W, Cabell M, Lam D, Macomber J, Short JM, Robertson DE, Miller C (2002) A novel, high performance enzyme for starch liquefaction: discovery and optimization of a low pH, thermostable alpha-amylase. *J Biol Chem* 277:26501–26507
- Robertson DE, Murphy D, Reid J, Antony MM, Link S, Swanson RV, Warren PV, Kosmotka A (1999) Esterases. US Patent 5,942,430
- Roels JA, van Tilburg R (1979) Temperature dependence of the stability and the activity of immobilized glucose isomerase. *ACS Symp Ser* 106:147–172
- Röhm O (1915) Verfahren zum Reinigen von Wäschestücken aller Art. Patent DE 283923
- Saari GC, Kumar AA, Kawasaki GH, Insley MY, O'Hara PJ (1987) Sequence of the *Ampullariella* sp. strain 3876 gene coding for xylose isomerase. *J Bacteriol* 169(2):612–618
- Saeki K, Okuda M, Hatada Y, Kobayashi T, Ito S, Takami H, Horikoshi K (2000) Novel oxidatively stable subtilisin-like serine proteases from *alkaliphilic bacillus* spp.: enzymatic properties, sequences, and evolutionary relationships. *Biochem Biophys Res Commun* 279:313–319
- Sanders JPM, van den Berg JA, Andreoli PM, Vos YJ, van Ee JH, Mulleners LJS (1985) Molecular cloning and expression in industrial microorganism species. Patent EP 0134048
- Saul DJ, Williams LC, Reeves RA, Gibbs MD, Bergquist PL (1995) Sequence and expression of a xylanase gene from the hyperthermophile *Thermotoga* sp. strain Fjss3-B.1 and characterization of the recombinant enzyme and its activity on kraft pulp. *Appl Environ Microbiol* 61:4110–4113
- Saunders CW, Guyer MS (1986) The production of human serum albumin in *Bacillus*: new gene fusions, plasmids and *Bacillus* strains useful in production of human serum albumin economically by cultivation. Patent EP 0229712a2 13
- Schmid A, Dordick JS, Hauer B, Kiener A, Wubbolts M, Witholt B (2001) Industrial biocatalysis today and tomorrow. *Nature* 409:258–268
- Schrag JD, Li Y, Cygler M, Lang D, Burgdorf T, Hecht HJ, Schmid R, Schomburg D, Rydel TJ, Oliver JD, Strickland LC, Dunaway CM, Larson SB, Day J, McPherson A (1997) The open conformation of a pseudomonas lipase. *Structure* 5:187–202
- Schroen CG, Vandewiel S, Kroon PJ, Devroom E, Janssen AE, Tramper J (2000) Equilibrium position, kinetics, and reactor concepts for the adipyl-7-Adca-hydrolysis process [in process citation]. *Biotechnol Bioeng* 70:654–661
- Schumacher G, Sizmann D, Haug H, Buckel P, Boeck A (1986) Penicillin acylase from *E. coli*: unique gene-protein relation. *Nucleic Acids Res* 14:5713–5727
- Shendye A, Rao M (1993) Cloning and extracellular expression in *Escherichia coli* of xylanases from an alkaliphilic thermophilic bacillus sp. Ncim-59. *FEMS Microbiol Lett* 108:297–302
- Shibuya Y, Matsumoto K, Fujii T (1981) Isolation and properties of 7 β -(4-carboxybutanamido) cephalosporanic acid acylase-producing bacteria. *Agric Biol Chem* 45:1561–1567
- Simons PCM, Versteegh HAJ, Jongbloed AV, Kemme PA, Skump P, Bos KD, Wolters MGE, Beudeker RF, Verschoor G (1990) Improvement of phosphorus availability by microbial phytase in broilers and pigs. *Br J Nutr* 64:525–540
- Sio CF, Riemens AM, van der Laan JM, Verhaert RM, Quax WJ (2002) Directed evolution of a glutaryl acylase into an adipyl acylase. *Eur J Biochem* 269:4495–4504
- Spezio M, Wilson DB, Karplus PA (1993) Crystal structure of the catalytic domain of a thermophilic endocellulase. *Biochemistry* 32:9906–9916
- Stemmer WP (1994) Rapid evolution of a protein in vitro by DNA shuffling. *Nature* 370:389–391
- Stephenson K, Harwood CR (1998) Influence of a cell-wall-associated protease on production of alpha-amylase by *Bacillus subtilis*. *Appl. Environ Microbiol* 64:2875–2881
- Stephenson K, Carter NM, Harwood CR, Petitglatron MF, Chambert RG (1998) The influence of protein folding on late stages of the secretion of alpha-amylases from *Bacillus subtilis*. *FEBS Lett* 430:385–389
- Tamuri M, Kanno M, Ishii Y (1997) Heat and acid-stable alpha-amylase enzymes and processes for producing the same. US Patent 4283722
- Tawfik DS, Griffiths AD (1998) Man-made cell-like compartments for molecular evolution. *Nat Biotechnol* 16:652–656
- Tjalsma H, Noback MA, Bron S, Venema G, Yamane K, van Dijl JM (1997) *Bacillus subtilis* contains four closely related Type I signal peptidases with overlapping substrate specificities: constitutive and temporally controlled expression of different Sip genes. *J Biol Chem* 272:25983–25992
- Van den Burg B, Vriend G, Veltman OR, Venema G, Eijssink VG (1998) Engineering an enzyme to resist boiling. *Proc Natl Acad Sci USA* 95:2056–2060
- van der Laan JC, Gerritse G, Mulleners LJ, van der Hoek RA, Quax WJ (1991) Cloning, characterization, and multiple chromosomal integration of a *Bacillus* alkaline protease gene. *Appl Environ Microbiol* 57(4): 901–909
- Van der Laan JM, Teplyakov AV, Kelders H, Kalk KH, Misset O, Mulleners LJS, Dijkstra BW (1992) Crystal structure of the high-alkaline serine protease-Pb92 from *Bacillus alcalophilus*. *Protein Eng* 5:405–411
- Van Dijl JM, Dejong A, Vehmaanpera J, Venema G, Bron S (1992) Signal peptidase-I of *Bacillus subtilis*: patterns of conserved amino acids in prokaryotic and eukaryotic Type-I signal peptidases. *EMBO J* 11:2819–2822
- Van Eekelen CAG, van der Laan JC, Mulleners LJS (1988) Molecular cloning and expression of genes encoding proteolytic enzymes. Patent EP 0283075
- Van Eekelen CAG, Mulleners LJS, van der Laan JC, Misset O, Cuperus RA, Alensink JH (1989) Novel proteolytic enzymes and their use in detergents. Patent EP 0328229
- van Leen RW, Bakhuis JG, van Beckhoven RF, Burger H, Dorssers LC, Hommes RW, Lemson PJ, Noordam B, Persoon NL, Wagemaker G (1991) Production of human interleukin-3 using industrial microorganisms. *Biotechnology* 9:47–52
- Van Pouderoyen G, Eggert T, Jaeger KE, Dijkstra BW (2001) The crystal structure of *Bacillus subtilis* lipase: a minimal alpha/beta hydrolase fold enzyme. *J Mol Biol* 309:215–226
- Van Solingen P, Meijer D, van der Kleij WA, Barnett C, Bolle R, Power SD, Jones BE (2001) Cloning and expression of an endocellulase gene from a novel streptomycete isolated from an East African soda lake. *Extremophiles* 5:333–341
- Van Straten NCR, Duynstee HI, Devroom E, Van der Marel GA, van Boom JH (1997) Enzymatic cleavage of N-phenylacetyl-protected ethanolamine phosphates. *Liebigs Annalen* 1997(6):1215–1220
- Verhaert RM, Riemens AM, van der Laan JM, van Duin J, Quax WJ (1997) Molecular cloning and analysis of the gene encoding the thermostable penicillin G acylase from *Alcaligenes faecalis*. *Appl Environ Microbiol* 63:3412–3418
- Verhaert RM, Beekwilder J, Olsthoorn R, van Duin J, Quax WJ (2002) Phage display selects for amylases with improved low pH starch-binding. *J Biotechnol* 96:103–118
- Wallerstein L (1939) Enzyme preparation from microorganisms. *Ind Eng Chem* 31:1218–1224
- Welker NE, Campbell LL (1967a) Comparison of the alpha-amylase of *Bacillus subtilis* and *Bacillus amyloliquefaciens*. *J Bacteriol* 94:1131–1135
- Welker NE, Campbell LL (1967b) Unrelatedness of *Bacillus amyloliquefaciens* and *Bacillus subtilis*. *J Bacteriol* 94:1124–1130
- Wind RD, Uitdehaag JC, Buitelaar RM, Dijkstra BW, Dijkhuizen L (1998) Engineering of cyclodextrin product specificity and pH optima of the thermostable cyclodextrin glycosyltransferase from *Thermoanaerobacterium thermosulfurigenes* Em1. *J Biol Chem* 273:5771–5779
- Wong HC, Ting T, Lin H-C, Reichert F, Myambo K, Watt KWK, Toy PL, Drummond RJ (1991) Genetic organization and regulation of the xylose degradation genes in *Streptomyces rubiginosus*. *J Bacteriol* 173: 6849–6858
- Xie Y, van De SE, De Weerd T, Wang NH (2001) Purification of adipoyl-7-amino-3-deacetoxycephalosporanic acid from fermentation broth using stepwise elution with a synergistically adsorbed modulator. *J Chromatogr A* 908:273–291
- Yamagata H, Udaka S (1994) Starch-processing enzymes produced by recombinant bacteria. *Bioprocess Technol* 19:325–340

- Ye RQ, Kim JH, Kim BG, Szarka S, Sihota E, Wong SL (1999) High-level secretory production of intact, biologically active staphylokinase from *Bacillus subtilis*. *Biotechnol Bioeng* 62:87–96
- Yuuki T, Nomura T, Tezuka H, Tsuboi A, Tsukagoshi H, Yamagata N, Udaka S (1985) Complete nucleotide sequence of gene coding for heat-and pH-stable alpha-amylase of *Bacillus licheniformis*: comparison of the amino acid sequence of 3 bacterial liquefying alpha-amylases deduced from the DNA. *J Biochem* 98:1147–1156
- Zhao HM, Giver L, Shao ZX, Affholter JA, Arnold FH (1998) Molecular evolution by Staggered Extension Process (STEP) in vitro recombination. *Nat Biotechnol* 16:258–261
- Zhu GP, Luo D, Cai YF, Zhu XY, Teng MK, Wang YZ (2000) Mutations of Q20I and G247D improved the specific-activity and optimum pH of glucose isomerase. *Sheng Wu Gong Cheng Xue Bao* 16:469–473

7 Diversity and Biotechnological Applications of Prokaryotic Enzymes

Alane Beatriz Vermelho¹ · Eliane Ferreira Noronha² · Edivaldo Ximenes Ferreira Filho² · Maria Antonieta Ferrara³ · Elba Pinto S. Bon⁴

¹Laboratory of Microbial Peptidases, Institute of Microbiology Paulo de Góes, BIOINOVAR - Biotechnonology center, Federal University of Rio de Janeiro (UFRJ), Rio de Janeiro, RJ, Brazil

²Laboratory of Enzymology, Department of Cellular Biology, Federal University of Brasilia (UNB), Brasilia, Brazil

³Medicines and Drugs Technology Institute, Oswaldo Cruz Foundation, Rio de Janeiro, RJ, Brazil

⁴Laboratory of Enzyme Technology, Biochemistry Department, Chemistry Institute, Federal University of Rio de Janeiro (UFRJ), Rio de Janeiro, RJ, Brazil

Introduction: Biotechnology and Microorganisms	214	The Importance and Prospective Market of Industrial and Specialty Enzymes	233
Lipases	214	Introduction	233
Definition and Properties	214	Industrial Enzymes	233
Classification	216	Specialty Enzymes	234
Prokaryotic Lipases	216	Perspectives	235
Improving Activity and Stability of Lipases	217		
Biotechnological Applications	217		
Amylases	218	Abstract	
Cellulases	220	The global enzyme market was estimated at US \$5 billion in 2009. Taking into consideration the compound annual growth rate (CAGR) of 6 % for the next 5 years, this market is expected to reach US \$7 billion by 2015. Enzymes have been used in a wide range of applications in the fuel, pharmaceutical, brewing, food, animal feed, bioremediation, detergent, paper, and textile industries. The industrial sector is under continuous pressure to use more environmentally friendly processes and to find new methods to make products more competitive. Consequently, microbial enzymes are increasingly replacing conventional chemical catalysts in a range of industrial processes. Microbial enzymes present some advantages when compared to enzymes sourced from plants and animals which may be seasonal. There is a reliable supply of raw material to make microbial enzymes whenever necessary, and their production in bioreactors is easily controlled and predictable; excreted microbial enzymes are more robust in comparison to the intracellular animal and plant enzymes, and the microbial genetic diversity is a source of biocatalysts with a wide specificity range. This chapter is a review of the important prokaryotic enzyme families used in present-day biotechnology. A comprehensive survey on lipases, amylases, transglutaminases, cellulases, peroxidases, and peptidases, including keratinases, is presented. This chapter also focuses on the types of catalyzed reactions, the mechanisms of enzyme actions, and the main producing microorganisms, as well the contribution of molecular biology for enzyme production.	
Definition and Properties	220		
Cellulolytic Bacteria	221		
Biotechnological Applications	223		
Peroxidases	224		
Peptidases	225		
Definition and Classification	225		
Peptidases in the Prokaryotes	225		
Aspartic Peptidases	225		
Metallopeptidases	227		
Cysteine Peptidases	227		
Serine Peptidase	227		
Asparagine Peptidases	229		
Proteasome	229		
Biological Roles of Peptidases	229		
Biotechnological Applications	229		
Transglutaminases	230		
Definition and Catalyzed Reactions	230		
Microbial TGases (MTGase)	231		
Role of Microbial Transglutaminase	231		
Biotechnological Applications	232		

Despite the promising performance of newly studied enzymes in the laboratory, their application in the industrial milieu might fail due to their lack of robustness. However, as anaerobic, extremophilic, and marine bacteria might be a source of enzymes with superior chances of success in biotechnological processes, a great deal of laboratory effort has been concentrated on their production and characterization. Furthermore, the design of novel enzymes as well as molecular approaches such as enzyme evolution and metagenomic approaches can be used to identify and develop novel biocatalysts from uncultured bacteria—a treasure of unknown proteins.

Introduction: Biotechnology and Microorganisms

Biotechnology is defined by the European Federation of Biotechnology as “the integration of natural sciences and organisms, cells, parts thereof, and molecular analogs for products and services” which can be translated from legalese to “a technology which employs practical applications of living organism or the components of living organisms.” Biocatalysis is a major part of biotechnology and can be performed by living cells and/or their enzymes to catalyze chemical reactions (Carvalho 2011). Thus, biocatalysis has emerged as a methodology that allows the development of eco-friendly processes within the basic principles of sustainable chemistry (Busto et al. 2010). Industrial biotechnology also known as white biotechnology involves the use of enzymes and microorganisms from renewable sources to aggregate value to chemicals (for manufacturing products) in the chemical, food and feed, paper and pulp, textile, and energy industries (Wohlgemuth 2010). Enzymes are proteins that are produced by living organisms to catalyze metabolic biochemical reactions necessary for all life processes. The use of pure enzymes in biocatalysis has several advantages including its specificity for selected reactions. However, enzyme isolation and purification can be quite expensive and time consuming (Zhao et al. 2007).

Microbial enzymes present some advantages when compared to enzymes from plant and animal sources. Their production and growth conditions such as pH, temperature, and aeration are easily controlled and predictable in bioreactors. They are more potent, showing different specificities; they have a broad biochemical diversity and feasibility of mass culture, and there is a reliable supply of raw material to make microbial enzymes. Prokaryotes are a source of a wide array of enzymes, and a single strain produces different types of cellular or secreted enzymes. Enzyme production is dependent on the growth conditions and on the cellular development. The different habitats and extreme microenvironments around the world favor a diversity of microbial enzymes (Bode et al. 2002; Carvalho 2011). Another advantage of microbial enzymes is their ease of genetic manipulation (Vermelho et al. 2008; Zhang and Kim 2010). One of the most important tools for industrial biotechnology is protein engineering, and several enzymes have already been engineered to function better in industrial processes. This method can optimize enzyme performance in terms of activity,



selectivity, thermostability, tolerance to organic solvents, enantioselectivity, and substrate specificity for the enzymatic process to be commercially viable (Luetz et al. 2008; Tang and Zhao 2009). Another important way to improve enzyme usability in industry is metabolic engineering. In this process, enzyme transport and regulatory functions as well as the control gene expression regulation in microorganism can be redirected by metabolic engineering (Keasling 2010; Otero and Nielsen 2010).

Synthetic biology is an emerging field, which is growing and still presents great challenges. Synthetic biology can be defined as the design and construction of new biological functions and systems not found in nature. The aim is to create a synthetic genome, which is easier to understand and manipulate compared to those available in nature (Benner and Sismour 2005; Chen et al. 2010). For example, designed microorganisms might be capable of producing pharmaceutical compounds that are extremely challenging for existing methods of chemical or biological synthesis. Gibson et al. (2008) synthesized a 582,970 base pair *Mycoplasma genitalium* genome. This synthetic genome, named *M. genitalium* JCVI-1.0, contains all the genes of wild-type *M. genitalium* G37 except MG408, which was disrupted by an antibiotic marker to block pathogenicity and to allow for selection (Gibson et al. 2008).

Also, another integrated strategy used in industrial biotechnology is systems biology which is the quantitative analysis, often through the use of predictive mathematical models, of biological systems and is a dynamic interaction between various disciplines and approaches via computer simulation (Otero and Nielsen 2010). Cellular networks are analyzed and optimized for application in the development of strains and bioprocesses, via computer simulation. This involves “omics” technologies, such as (1) transcriptome (genome-wide study of mRNA expression levels), (2) proteome (analysis of structure and function of proteins and their interactions), (3) metabolome (measurement of all metabolites to access the complete metabolic response to a stimulus), and (4) fluxome analysis (measurement of all metabolites to access the complete metabolic response to a stimulus), and also advanced mathematical modeling tools such as genome-scale metabolic modeling (Tang and Zhao 2009; Otero and Nielsen 2010).  [Figure 7.1](#) summarizes the major tools and strategies used in industrial biotechnology.

Lipases

Definition and Properties

Lipases are serine hydrolases (EC 3.1.1.3) that catalyze the hydrolysis of ester bonds in long-chain triacylglycerols with a concomitant release of fatty acids and glycerol (Jaeger et al. 1999; Sharma et al. 2001). The action mechanism of lipases is shown in  [Fig. 7.2](#).  [Figure 7.3](#) represents a structure of a lipase from *Pseudomonas aeruginosa* (Nardini and Dijkstra 1999).

Lipases are a diverse group of enzymes acting on a great variety of substrates, including natural oils, synthetic triglycerides, and esters of fatty acids. The reaction is catalyzed at the

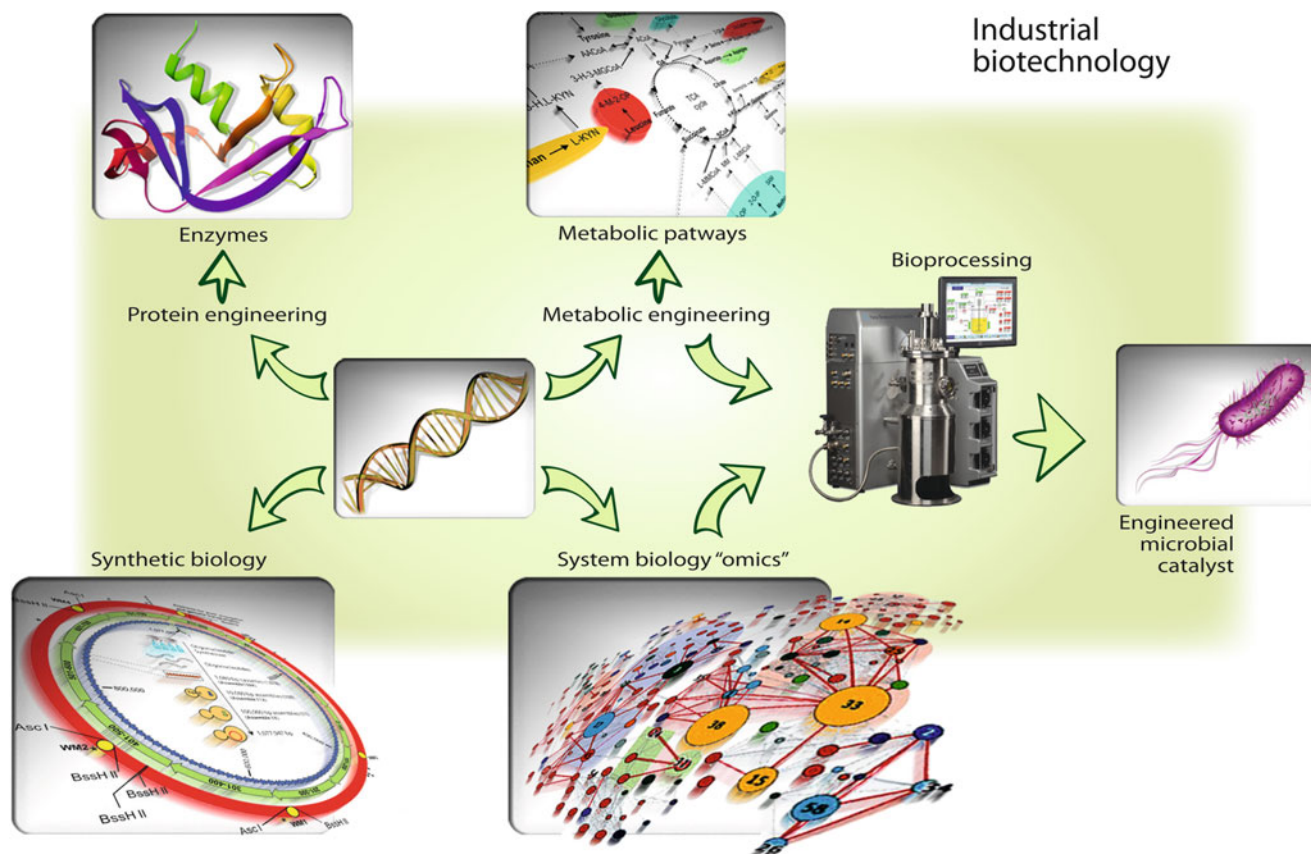

■ Fig. 7.1
Strategies used in industrial biotechnology

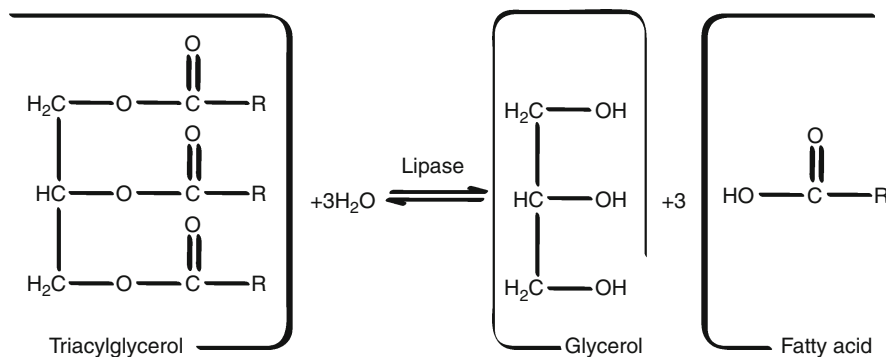

■ Fig. 7.2
The catalytic action of lipase (Jaeger et al. 1999)

lipid-water interface, forming equilibrium between the monomeric, micellar, and emulsified states (Jaeger et al. 1999; Sharma et al. 2001; Gupta et al. 2004). The mechanism of lipase adsorption on the oil/water interface before hydrolysis involves substantial conformational changes in enzyme architecture during catalysis (Arpigny and Jaeger 1999; Saxena et al. 2003). Lipases are highly specific as chemo-, regio-, and enantioselective biocatalysts. Moreover, they display, under micro-aqueous conditions, reverse reactions, resulting in esterification, alcoholysis,

and acidolysis (Jaeger et al. 1999, 2001). In addition, lipases also possess the ability to carry out esterolytic activity (Gupta et al. 2004). The use of lipases in organic media has been an extensive area of research (Cardenas et al. 2001; Peng et al. 2010). Organic media has several advantages such as increased enzyme activity and stability, regiospecificity and stereoselectivity, higher solubility of substrate and ease of product recovery, and ability to shift the reaction equilibrium toward the synthetic direction. However, only a limited number of lipases belonging to a few



Fig. 7.3
Conformation of lipase from *P. aeruginosa* lipase with a phosphonate inhibitor. α -helices (helical ribbons), β -strands (arrows), and coils (ropes), phosphonate inhibitor covalently bound to the nucleophile and the calcium ion (ball and stick) (based on Nardini and Dijkstra 1999)

species have been demonstrated to have adequate stability and biosynthetic capabilities to allow routine use in organic reactions, and native enzymes almost always exhibit low activity in organic solvents (Peng et al. 2010).

Classification

Lipases can be classified into two main groups: true lipases (triacylglycerol acylhydrolases, E.C.3.1.1.3) and carboxylesterases (EC.3.1.1.1). These enzymes are members of the α/β hydrolase fold superfamily and share a sequence consensus of G-X-S-X-G located near the active site serine with a characteristic β -turn- α motif named the “nucleophilic elbow” (Jaeger and Reetz 1998; Nardini and Dijkstra 1999; Gupta et al. 2004; Mala and Takeuchi 2008; Messaoudi et al. 2010). Furthermore, their active sites contain a catalytic triad composed of conserved serine, aspartic or glutamic acid, and histidine residues and oxyanion hole, which is formed by the backbone amides of two conserved residues (Nardini and Dijkstra 1999; Fan et al. 2009). According to Arpigny and Jaeger (1999), lipases are classified into eight families and subdivided

into six subfamilies. The criteria adopted for this classification were the conserved sequence motifs and biological properties of the enzymes (Sangeetha et al. 2011). These families comprise lipases of different characteristics, such as true lipases (family I), the G-D-S-L motif located at the active site (family II), and amino acid sequence similarity to various bacterial nonlipolytic enzymes (family V). Most lipases are members of family I that catalyze the hydrolysis and synthesis of long-chain substrates with low water solubility, and are classified into seven subfamilies (Yu et al. 2010). Recently, a lipase from hyperthermophilic bacterium *Fervidobacterium changbaicum* CBS-1 was described by phylogenetic analysis as a new member of the bacterial lipase family V and displayed some common features of α/β hydrolase, such as the nucleophilic G-X-S-X-G sequence and the catalytic triad composed of Ser134, Asp266, and His294 (Cai et al. 2011). *Fervidobacterium nodosum* Rt17-B1 was reported to produce a novel lipase classified as member of the new subfamily I.8 composed of an α/β -hydrolase fold and a lid domain comprised of four α -helices (Yu et al. 2010). Lipases from subfamily I.4 are described as mesophilic and more active in the neutral to alkaline range (pH 7–11), and also they are restricted to the medium or short-chain fatty acids as substrates (Ruiz et al. 2002). A lipase from *Bacillus* sp. HH-01 exhibited 82 % amino acid sequence identity with the subfamily I.4 lipase LipA of *Bacillus subtilis* 168 (Kamijo et al. 2011). Lazniewski et al. (2011) have identified a novel family of transmembrane lipases of the α/β -hydrolase fold that may catalyze the initial steps in the modification of various glycerol esters (triglycerides, lysophospholipids, or phospholipids), which are essential for ATP production in the cell.

Prokaryotic Lipases

Lipases are ubiquitous in nature, and those from bacterial origin are mainly produced by the genera *Bacillus*, *Pseudomonas*, *Staphylococcus*, and *Burkholderia* (Arpigny and Jaeger 1999; Gupta et al. 2004; Fan et al. 2009). To date, a large number of lipases from bacteria have been extensively studied, both from the biochemical and from the genetic point of view (Sangeetha et al. 2011). Mesophilic and thermophilic bacteria are the primary active organisms in the composting process (Ohnishi et al. 2011). Bacteria belonging to the genus *Bacillus* are very active during the compost process, decomposing organic compounds such as sugar, proteins, lipids, and carboxylic acids. Bacterial lipases are mostly extracellular and are produced by submerged culture. Halophilic enzymes or bacteria require NaCl for activity or growth, while halotolerant forms are able to grow in the absence of NaCl (Garabito et al. 1998; Kanlayakrit and Boonpan 2007). Cold-adapted bacteria are a potential source of cold-active lipases, which show a high level of flexibility around the catalytic site and high specific activity at low temperatures (Joseph et al. 2008; Chen et al. 2011). The increasing flexibility of the lipase structure makes the accommodation of substrates at low temperatures possible. The cold-active lipase activity of culturable psychrophilic bacteria associated with sandy sediment from Nella Fjord, Eastern Antarctica, was investigated by

Yu et al. (2011). In this case, 12 % of the strains possessed lipase activity, and lipase activity was detected in members of *Sulfitobacter*, *Colwellia*, *Glaciecola*, *Photobacterium*, and *Pseudomonas*. Lipases are constitutive as well as inductive in nature (Hasan et al. 2009). Lipid sources such as oil, triacylglycerols, fatty acids, hydrolyzable esters, tweens, bile salts, and glycerol are reported as good inducers of lipase (Dharmsthiti et al. 1998; Rath et al. 2001; Gupta et al. 2004; Treichel et al. 2010). The synthesis of lipase is influenced by several factors, including availability of carbon and nitrogen sources; the presence of activators, stimulators, inhibitors, surfactants, incubation temperature, pH, and oxygen tension; and the amount and source of inoculums (Hadeball 1991; Chartrain et al. 1993; Hasan et al. 2009). *F. nodosum* Rt17-B1, an anaerobic thermophilic bacterium of the eubacterial order Thermotogales, is capable of growing at high temperatures with an optimum of about 80 °C (Yu et al. 2010).

Improving Activity and Stability of Lipases

Lipases of microbial origin represent one of the most used classes of enzymes in biotechnological applications and organic chemistry. Advances in the development of both experimental and computational protein engineering tools have led to the development of lipases with improvement in certain desired characteristics for industrial use (Schmidt-Dannert 1999; Bommarius et al. 2011; Brustad and Arnold 2011). Moreover, the metagenome approach facilitates the discovery of novel enzymes from microbial sources, and the number of potentially useful biocatalysts has increased in the past decade. The use of protein engineering methods to modify lipases on the molecular level is an important tool in order to attend the desired characteristics including stability and specificities. *Pseudomonas mendocina* lipase was the first enzyme to be engineered (Svendsen 2000). Induced mutation by physical and chemical methods, including UV irradiation, γ -ray, fast neutron irradiation, nitrosoguanidine (NTG), diethyl sulfate, and nitrous acid, have been applied to breed lipase-producing microorganisms. With these simple methods, the lipase yield can be improved by one- to tenfold; however, the low positive mutation rate, the long periodicity, and the work of screening limited its widespread application (Shu et al. 2010). With the development of gene engineering technology, many lipase genes have been cloned. Using recombinant DNA technology, heterologously expressing lipase genes have been produced. The recombinant *Thermomyces lanuginosus* lipase (Novozyme) was produced in an *Aspergillus oryzae* expression system. Due to factors such as the protein secretion mechanism and posttranslation, exogenous lipase genes may not be able to achieve significant overexpression, and in this case a homologous expression of the lipase gene is desired. An amplification of lipase gene copies was carried out with the aid of low- and high-copy-number plasmids, and the lipase yield of the recombinant *P. alcaligenes* was up to 23-fold. The expression of the gene was optimized in its original host, *P. alcaligenes* (Gerritse and Hommes 1998).

In Gram-negative bacteria, the lipases are extracellular enzymes and fold into an enzymatically active conformation in the periplasm. To be secreted in a correct conformation, lipases require specific intermolecular chaperone proteins, the Lif proteins. Due to this, the expression of the gene lipase in plasmid with gene *lif* increases the lipase yield more than the expression of the lipase gene in plasmid without the gene *lif* (Rosenau and Jaeger 2000; Shu et al. 2010). One approach used to prevent the degradation of lipases by peptidase and in order to increase the yield and the stability of lipases is the construction of a peptidase-deficient strain. In *B. subtilis* multiple peptidase genes were removed with success. Other strategy for a better lipase yield includes an improvement of lipase gene expression (Ma et al. 2006).

Enzyme immobilization techniques have been revealed as a powerful tool to enhance most enzyme properties such as stability, activity, specificity and selectivity, and reduction of inhibition. Several methods had been used including cross-linked enzyme aggregates (CLEAs) (Wang et al. 2011), entrapment, and support-based immobilization (Brady and Jordaan 2009).

Biotechnological Applications

Lipases from bacteria have a wide spectrum of biotechnological applications, playing a vital role in the food, pharmaceutical, detergent, and dairy industries (Gosh et al. 1996; Sharma et al. 2001; Gupta et al. 2004; Aravindan et al. 2007; Mala and Takeuchi 2008; Hasan et al. 2006, 2010; Sangeetha et al. 2011). Enzymes can reduce the environmental load of chemicals used in industrial processes. Furthermore, they are nontoxic and leave no harmful residues (Hamid et al. 2003). For industrial applications, attention has focused on particular classes of lipases such as those from the genus *Pseudomonas* with special attention from the detergent industry (Gosh et al. 1996; Reetz and Jaeger 1998; Cardenas et al. 2001; Rahman et al. 2005; Cai et al. 2011). Applications of bacterial lipases have been increased due to their stability when exposed to severe conditions, including low and high temperatures (Kanjanavas et al. 2010; Yu et al. 2011). Cold-active lipases may find applications in detergent and food industries (Joseph et al. 2008; Yu et al. 2011). For the detergent industry, they can be used to develop ingredients capable of working efficiently at low to medium temperatures. In the food industry, cold-active lipases are particularly attractive for the processing of foods due to their high catalytic activity under low-temperature conditions that minimize spoilage and alterations in flavor and nutritional values. In this case, cold-active lipases can serve as rennet substitutes and accelerate the maturation of slow-ripening cheeses. Halophilic lipases are also described to have applications in the food industry (Kanlayakrit and Boonpan 2007). The properties of halophilic lipase from a halotolerant *Staphylococcus warneri* PB233 may lead to potential applications in fish sauce production for flavor and aroma improvement.

Lipases from thermophilic bacteria have also received attention from the detergent and food industries (Hamid et al. 2003).

Thermostable lipases show good stability toward organic solvents and exhibit higher activity at elevated temperatures than nonthermostable lipase. *F. nodosum* Rt17-B1 produces a lipase that is more active at 70 °C and pH 9.0 (Yu et al. 2010). The thermotolerant lipase-producing *Bacillus* strains have potential use in certain manufacturing processes, including antibiotic production, biosurfactant and biofilm production, and biodegradation of recalcitrant substances (Pohlenz et al. 1992; Zock et al. 1994; Yakimov et al. 1995). A secreted lipase from thermotolerant *Bacillus* sp. RN2 was organic and detergent tolerant, showing potential to be used in manufacturing processes (Kanjanas et al. 2011).

Biodiesel (fatty acid methyl ester) derived from the transesterification of triglycerides is emerging as a viable alternative to replace petroleum-based diesel (Charpe and Rathod 2010; Gupta et al. 2011). Transesterification, which is the displacement of alcohol from an ester by another alcohol, has been used as an alternative process to reduce the viscosity and to improve the physical properties of biodiesel whereas the direct use of vegetable oils is considered unfeasible due to a number of parameters such as high viscosity, acid composition, and free fatty acid content of the triglycerides (Fukuda et al. 2008). Furthermore, enzymatic transesterification provides several advantages such as reducing process operations in biodiesel fuel production and an easy separation of the glycerol by-product. The advantages of using biodiesel instead of diesel fuel include low toxicity, high biodegradation, and lower emission of particulate matter and its derivation from renewable energy sources. When compared to refined oil, the production of biodiesel by transesterification from sunflower frying oil is an economic alternative because of its low cost. The use of *Pseudomonas fluorescens* lipase as a catalyst for the transesterification of waste sunflower frying oil has been reported by Charpe and Rathod (2010). The process parameters for the reaction were optimized, including temperature and enzyme concentration, and the enzyme showed a high substrate conversion.

Protein engineering via direct evolution or rational design has been applied as a tool to design and alter the properties of lipases with special attention to thermostability, enantioselectivity, and solubility and a view to be used in a variety of biotechnology applications (Böttcher and Bornscheuer 2010). The industrial purification strategies for lipase include inexpensive, rapid, high yielding, and amenable to large-scale operations (Saxena et al. 2003). These purified enzymes are required for the biocatalytic production of fine chemicals, pharmaceuticals, and cosmetics (Dheeman et al. 2011). Therefore, new technologies such as membrane processes, aqueous two-phase systems, and immunopurification are being increasingly used in industrial processes for the purification of lipases.

The world market for lipases is the fastest growing segment driven by its growing applications in the detergent and cosmetic markets (Rahman et al. 2005). Global Industry Analysts Inc. has announced a comprehensive analysis on the worldwide market for industrial enzymes. According to this analysis, the world market for industrial enzymes is forecasted to reach US \$3.74 billion by 2015, and lipases represent one of the major product

segments in the global industrial enzyme market with a high growth potential (<http://www.strategy.com/pressMCP-2178.asp>).

In conclusion, lipases are enzymes with an ability to carry out a wide variety of chemo-, regio-, and enantioselective transformations in both aqueous and nonaqueous media. Such enzymes show several applications in areas of industrial microbiology and biotechnology. Today, environmental issues are taken into account when it comes to industrial processes. Thus, enzyme technology contributes significantly to a reduction of these negative effects such as toxicity and emission of particulate matter. Environmental concerns and the depletion of oil reserves have resulted in research into the use of lipases for environmentally friendly and sustainable biofuel production.

Amylases

Starch is one of the most abundant organic macromolecules on earth and represents the major reserve of carbohydrates in plants. This macromolecule is a polysaccharide constituted by D-glucose units joined together by α -(1 → 4) linkages forming the linear structure called amylose which makes up 20–30 % of normal starch and α -(1 → 4) linkages with ramifications α -(1 → 6) forming amylopectin, the major component (70–80 %) of the starch molecule (Zeeman et al. 2010). In higher plants, starch biosynthesis is carried out in chloroplasts or specialized organelles named amyloplasts and storage as granules in many different organs, including seeds, fruits, tubers, and roots. The ramification degree, the structure, and the amylose/amylopectin content of these granules vary considerably depending on the source of starch and plant species (Van der Maarel et al. 2002).

The cereal seeds, tubers, starch storage roots, and bean/pea seeds are directly consumed as food in human diet or animal feed and are used as a source of starch. Extracted starch can be used to produce starch derivatives or hydrolyzed to produce soluble sugars, food additives, or glucose syrup. Also, extracted starch can be used for other applications in nonfood industries (Nghiem et al. 2011). For example, it is used as a thickener and as a source of renewable raw material for bioethanol production. The major source of starch for the world market is cornstarch holding more than 80 % of the market, but wheat, potato, cassava or tapioca, and to a lesser extent rice and sweet potato starches are also commercialized (Thomsen et al. 2008).

Maize starch is the major source of fermentable sugars for bioethanol production in the USA, but other starch-containing materials have been studied for this purpose. In Brazil, researchers are focusing their studies on alternative starch-containing raw materials, such as sweet potato, cassava, and industrial residues generated during the production of starch products. The production of bioethanol using starch as the raw material begins with a physical/thermal pretreatment and then chemical or enzymatic hydrolysis of the starch leading to liquefaction and production of sugars that are fermented to the end product, normally using yeasts and more commonly *Saccharomyces cerevisiae* (Thomsen et al. 2008; Sun et al. 2010). Starch enzymatic hydrolysis is an environmental friendly and less

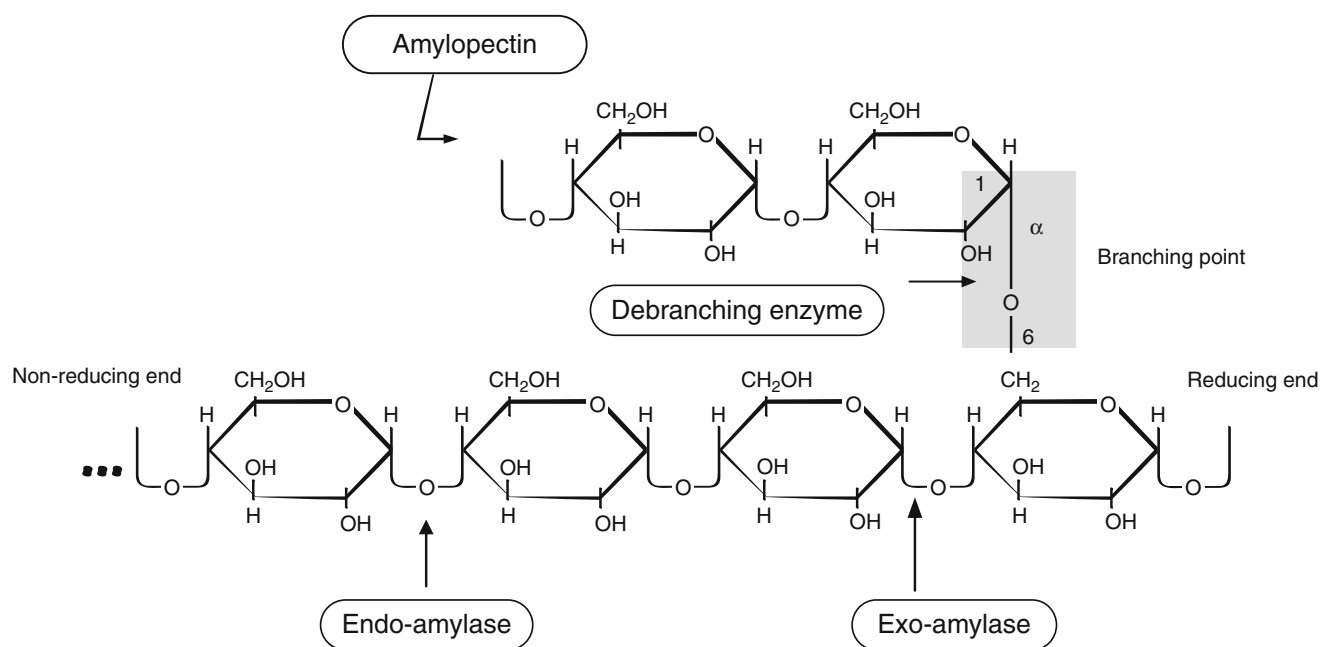

■ Fig. 7.4
The three major mode of action described for starch-degrading enzymes

pollutant procedure to starch liquefaction and is emerging as an alternative to the chemical treatments. In addition, biological catalysts are specific and produce fewer side products than chemical catalysts, improving the quality of the end product and its commercial value (Hahn-Hagerdal et al. 2006).

Efficient enzymatic degradation of starch-containing biomass in nature is carried out by a set of microorganisms according to the production and secretion of the starch-degrading enzymes. These enzymes can be classified into two major groups according to the mode of action or type of glycosidic linkages hydrolyzed: endo-amylases, exo-amylases, debranching enzymes, and transferases. The endo-amylases are able to hydrolyze randomly internal α -1,4- linkages from starch producing glucose or oligosaccharides with a variable number of glucose units. The most studied and industrially used endo-amylase is the α -amylase, α -1,4-glucan-4-glucanohydrolase (E.C. 3.2.1.1). Starch-degrading enzymes classified as exo-amylases are able to hydrolyze the starch link α -1,4-glycosidic sequentially from the reducing end producing glucose, maltose, or β -dextrin and are subdivided in β -amylases (E.C. 3.2.1.2), glucoamylases (E.C. 3.2.1.3), and α -glucosidase (E.C. 3.2.1.20) (Sun et al. 2010; Van der Maarel et al. 2002).

The β -amylases hydrolyze exclusively α -1,4-glycosidic linkages and produce maltose or β -dextrin. Glucoamylases and α -glucosidases hydrolyze the α -1,4- and α -1,6-glycosidic linkages of the starch producing glucose. In addition, these enzymes can be distinguished by the specificity of the substrate; the former presents more activity against polysaccharides and the second against malto-oligosaccharides. Special types of exo-amylases have been also described as cyclodextrin glucosyltransferase (E.C. 2.4.1.19), glucan 1,4- α glucanohydrolase (E.C. 3.2.1.133), and malto-oligosaccharides forming enzymes (E.C. 3.2.1.60 and

E.C. 3.2.1.98). Starch-debranching enzymes including isoamylase (E.C. 3.2.1.68) and pullulanase type I (E.C. 3.2.1.41) hydrolyze exclusively α -1,6-glycosidic linkages, as showed in Fig. 7.4, and are differentiated by the action against amylopectin observed for isoamylases. Type II pullulanase was also described and presents activity against glucans containing α -1,4- and α -1,6-glycosidic linkages (Van der Maarel et al. 2002).

Amylases classified in family 13 glycoside hydrolases have been described from the archaea to the bacteria domains. The genus *Bacillus* includes a set of species able to produce starch-degrading enzymes and has biotechnological potential as a source of these enzymes especially the α -amylases, which are the most frequent starch-degrading enzymes described for bacteria. In addition, *Bacillus* α -amylases present activity and are stable in temperatures over 50–60 °C, therefore are very attractive for industrial applications. *B. subtilis*, *Bacillus stearothermophilus*, *Bacillus licheniformis*, and *Bacillus amyloliquefaciens* have been widely used for commercial production of amylases and for the production of starch derivatives. The α -amylases produced by other bacteria and also archaea have to compete with the *Bacillus* enzymes that already present excellent thermophilic properties and high conversion rates (Prakash and Jaiswal 2010).

These enzymes present a conserved structural motif, a single polypeptide chain folded into three structural domains called A, B, and C. The N-terminal catalytic domain A consists of a $(\beta/\alpha)_8$, eight parallel β -strands arranged in a barrel encircled by eight α -helices. The domain B varies considerably in size and structure among amylases and presents the substrate-binding cleft. Domain C constitutes the C-terminal and is in the opposite position of domain B and presents a β -sandwich domain containing a Greek key motif. A remarkable characteristic of *Bacillus* α -amylases is the presence of three or four calcium ions,

one sodium ion, and a calcium-sodium-calcium metal triad bridge between domains A and B, which probably has an important role to maintain the correct protein structure and the thermal stability. Three amino acid residues (Asp 262, Glu 292 and Asp 359) are critical to the catalytic activity of *B. amyloliquefaciens* α -amylase; Asp 262 is the catalytic nucleophile while Glu 292 is the catalytic hydrogen donor. The residue Asp 359 seems to assist in the catalysis by hydrogen bonding to the substrate and by increasing the pKa value of Glu 292 (Prakash and Jaiswal 2010).

Pullulanases and glucoamylases from bacteria are also attractive for industrial purposes and are widely used in food industries. The glucoamylases from glycoside hydrolase family 15 present an invariable catalytic domain (α/α) sixfold bound to a non-catalytic domain barrel shape and an amino-terminal, β -sandwich domain.

Starch-binding domains are absent in prokaryotic glucoamylases. Most information available about the structure of the bacterial glucoamylases is derived from the structure of the glucoamylase produced by the thermophilic bacteria *Thermoanaerobacterium thermosaccharolyticum* (Marin-Navarro and Polaina 2011). The pullulanases also classified in family 13 glycoside hydrolase are used for the development of starch derivatives, because of their unique “debranching” activity that favors the production of high-fructose corn syrup and high maltose content syrups. The pullulanases can be also classified in the family 13 glycoside hydrolase and are used for the development of starch derivatives, because of their unique “debranching” activity that favors the production of high-fructose corn syrup and high maltose content syrup. Moreover, these enzymes have been used in the brewing industry for the production of low calorie and “light” beers since it carries out a more complete fermentation of the mash and leaves less residual sugar (Doman-Pytka and Bardowski 2004).

Starch-degrading enzymes have also been described for a set of bacteria such as *Anoxybacillus*, *Bacillus* spp., *Clostridium butyricum*, *Cytophaga* sp., *Geobacillus thermodenitrificans*, *Klebsiella pneumoniae*, *Lactobacillus amylophilus*, *Rhodospseudomonas* sp., *Streptococcus bovis*, and *Thermoanaerobacter* (Sun et al. 2010). However, there is a growing interest to find more robust enzymes suitable for industrial process such as those produced by the extremophilic bacteria and archaea. Extremophilic microorganisms are adapted to live at high or low temperatures, at high pressures on the seabed, at very low and high pH values (pH 0 to 3 or pH 10 to 12), or at very high salt concentrations (5 % to 30 %), and are very useful as a source of enzymes that are active at the extreme conditions required for industrial processes (Nichaus et al. 1999; Feller and Gerday 2003).

Extremely thermostable amylases and pullulanases, active above 100 °C and stable/active at acidic pH values will significantly improve the industrial starch bioconversion processes of liquefaction, saccharification, and isomerization. The lack of enzymes with these characteristics means that the bioconversion of starch to glucose and fructose must be carried out in a multistage process (step 1: pH 6.0 to 6.5, 95 to 105 °C; step 2: pH 4.5, 60 to 62 °C; step 3: pH 7.0 to 8.5, 55 to 60 °C),

which is accompanied by the formation of undesirable high concentrations of salts. In the final step, where high-fructose syrup is produced, salts have to be removed by expensive ion exchangers. The multistep process and the high salt production make this process more expensive. Thermostable and acidic active α -amylases and pullulanases have been described for thermophilic bacteria such as *Desulfurococcus mucosus*, *Pyrococcus* spp., *Staphylothermus marinus*, *Sulfolobus solfataricus*, *Thermococcus* spp., *Dictyoglomus thermophilum*, *Thermotoga maritime*, *Fervidobacterium pennavorans*, and *Thermus caldophilus*, and their potential use in the industrial process of starch liquefaction is under evaluation (Nichaus et al. 1999).

Novel approaches have been also developed to obtain amylases with desirable kinetics for industrial conditions. For example, the site-directed mutagenesis, random mutagenesis, and DNA-shuffling techniques have been used to obtain variants of amylase with desirable characteristics such as activity and stability at higher temperatures, acidic pH, and more oxidative stability (Chi et al. 2010; Kelly et al. 2009; Van der Maarel et al. 2002). The metagenomic approach is also a promising technique to find amyolytic genes from uncultured bacteria (Ferrer et al. 2007; Tasse et al. 2010). This technique is cultivation independent and provides the screening of a set of genomes of a microbial community.

Cellulases

Definition and Properties

Cellulose is the major constituent of all plant materials and, thus, is the most abundant of organic macromolecules on earth (Sukuruman et al. 2005; Rubin 2008; Li et al. 2009). Cellulose accounts on average for 40 % by weight of biomass and represents about 1.5×10^{12} t of the total biomass production (Sukuruman et al. 2005). Cellulose is described as a crystalline and linear polymer of glucopyranose units joined together by β -(1 \rightarrow 4) linkages. The matrix of polysaccharides (holocellulose) presents an enormous structural diversity in the plant cell wall, and the enzyme systems that catalyze the hydrolysis of such complex substrates are composed of endoenzymes that cleave internal glycosidic linkages, exoenzymes that remove sugar residues from main chain ends, and debranching enzymes (Andreas and Filho 2008). The recalcitrant, heterogeneous, and dynamic structure of plant cell wall, composed of polysaccharides, proteins, and lignin, is the major bottleneck and strategic barrier to enzymatic attack and is largely responsible for the high cost of lignocelluloses conversion (Himmel et al. 2007; Lagaert et al. 2009; Wei et al. 2009; King et al. 2011). Moreover, three other types of proteins are indirectly involved in the degradation process of holocellulose: the nonenzymatic proteins that are responsible for the cell wall loosening, the enzyme group that acts on non-glycosidic linkages of cell wall components, and finally those termed as auxiliary enzymes that release small molecules as a result of lignocellulose pretreatment

(Arantes and Saddler 2010; Banerjee et al. 2010; Gao et al. 2010; Moreira et al. 2011). The role of amorphogenesis in the initial stage of enzymatic saccharification of cellulose is to non-hydrolytically loosen or disrupt the cellulose fibril network (Arantes and Saddler 2010).

An enzymatic synergism is required for the complete hydrolysis of cellulose, and basically, three types of enzymes are involved in the breaking down of cellulose (Wilson and Irwin 1999). The exo- β -1,4-glucanase or cellobiohydrolase (EC 3.2.1.91) hydrolyses terminal glycosidic linkages and liberates cellobiose units from nonreducing and reducing ends, while endo- β -1,4-glucanase (EC 3.2.1.4) cleaves internal glycosidic bonds at random or at specific positions, usually internally. There is evidence that some cellulases present endo- and exo-acting mechanisms (Davies and Henrissat 1995; Maki et al. 2009) so that cellobiohydrolases are described as active on the crystalline regions of cellulose and endoglucanases are typically active on the more soluble amorphous region of the cellulose crystal. Furthermore, the presence of β -1,4-glucosidase (EC 3.2.1.21) that is active on cellooligomers and cellobiose is essential for complete hydrolysis of cellulose to glucose monomers. A typical cellulase system is composed of a carbohydrate-binding domain at the C-terminal joined by a short poly-linker region to the catalytic domain at the N-terminal (Maki et al. 2009). An important question raised by Wilson and Irwin (1999) refers to multiple forms of cellulases and their catalytic action on only one type of bond (β -1,4 linkage). Within this context, we can speculate that most known cellulolytic bacteria produce cellulose-degrading enzymes with different properties during the hydrolysis of crystalline cellulose structures of plant cell wall at different rates. Cellulase shows two conserved mechanisms of acid/base hydrolysis of the glycosidic bonds with retention or inversion of the anomeric configuration at the cleavage point (Hancock et al. 2006; Siqueira and Filho 2010). Retention occurs via a double displacement reaction and inversion via a single displacement reaction (Rye and Withers 2000; Maki et al. 2009). Both mechanisms involve stabilization of an oxycarbonium ion by electrostatic interaction and a pair of carboxylic acids at the active site. Some cellulases work via two consecutive single displacements in which the anomeric configuration is retained, while others catalyze single displacement reactions with inversion of the configuration. However, the physiological role of these reaction mechanisms remains to be established. Moreover, elucidation of the action mechanism of the cellulase system with natural polymeric substrates is complicated because the latter undergoes repetitive attacks by the enzyme. However, considerable information relevant to the action mechanism can be obtained by analysis of the products of hydrolysis and kinetic parameters using appropriate oligosaccharides. The occurrence of multiple cellulases is often described in cellulolytic bacteria (Gilbert and Hazlewood 1993). The multiplicity of cellulases may be due to differential mRNA processing, partial proteolysis, or differences in the degree of glycosylation.

Efficient enzymatic degradation and complete utilization of agricultural and forestry wastes for single cell protein production by microorganisms require the conversion of cell wall

polysaccharides, including cellulose, into their respective sugar components before being incorporated into microbial biomass. Moreover, the economic viability of biomass-based processes depends on the effective bioconversion and utilization of the cellulose fraction of the plant cell wall (Kumar et al. 2008; Zhang 2008). Enzymatic rather than acid-mediated hydrolysis of cellulose is advantageous because of the high efficiency of conversion, the absence of substrate loss due to chemical modifications, the mild conditions (non-corrosive), and also it is environmentally friendly. Susceptibility of the cellulose polymer from plant cell wall to enzymatic degradation is largely determined by its accessibility to the cellulase system or to other metabolites produced in bacteria. According to Popa (1998), the direct contact between enzymes or the metabolic products and the components of the cell wall is an essential condition for their hydrolytic and oxidative degradation. The high degree of insolubility of cellulose in water and its intimate contact with hemicelluloses and lignin in the cell wall make the above physical contact possible through the cellulase diffusion in the cell wall matrix.

Cellulolytic Bacteria

Bacteria have been isolated from different sources, such as forestry, agricultural waste, soil, and feces of ruminants, and they have been investigated intensively in terms of their ability to produce cellulase. To date, most of the fungal glycoside hydrolases have been tested for lignocelluloses degradation, and emphasis has been given to their potential to produce high amounts of extracellular hydrolases (Banerjee et al. 2010). Bacterial glycoside hydrolases are often more complex than fungal hydrolases and are often expressed in multienzyme complexes providing increased function and synergy and are described as a plentiful source of enzymes able to degrade lignocellulose structures (Maki et al. 2009; Gao et al. 2010). Within the same line of reasoning, cellulases of bacterial origin can be classified as complexed and noncomplexed enzyme systems (Gilbert and Hazlewood 1993; Sukuruman et al. 2005). Noncomplex cellulase systems from aerobic bacteria are composed of typical cellulolytic enzymes while multi-complex enzyme systems (cellulosome) are mainly produced by anaerobic bacteria (Wilson and Irwin 1999; Bayer et al. 2008; Pason et al. 2010). However, cellulolytic enzymatic complexes have also been described for Bacillus species, such as the facultative anaerobic bacterium *Paenibacillus curdlanolyticus* (Waeonukul et al. 2009). The cellulosome, described by Bayer et al. (2004) as a multienzyme machine for degradation of plant cell wall polysaccharides, is highly active in crystalline cellulose and can carry out several different enzyme activities including endoglucanase, exoglucanase, cellobiose phosphorylase, cellodextrin phosphorylase, β -glucosidase, xylanase, and laminarinase, linked to the scaffolding protein (Demain et al. 2005).

Among the anaerobic thermophilic bacteria, *Clostridium thermocellum* is the most studied, and its cellulosome has been widely investigated (Bayer et al. 2004, 2008; Schwarz et al. 2004; Demain et al. 2005; Zverlov and Schwarz 2008). This complex

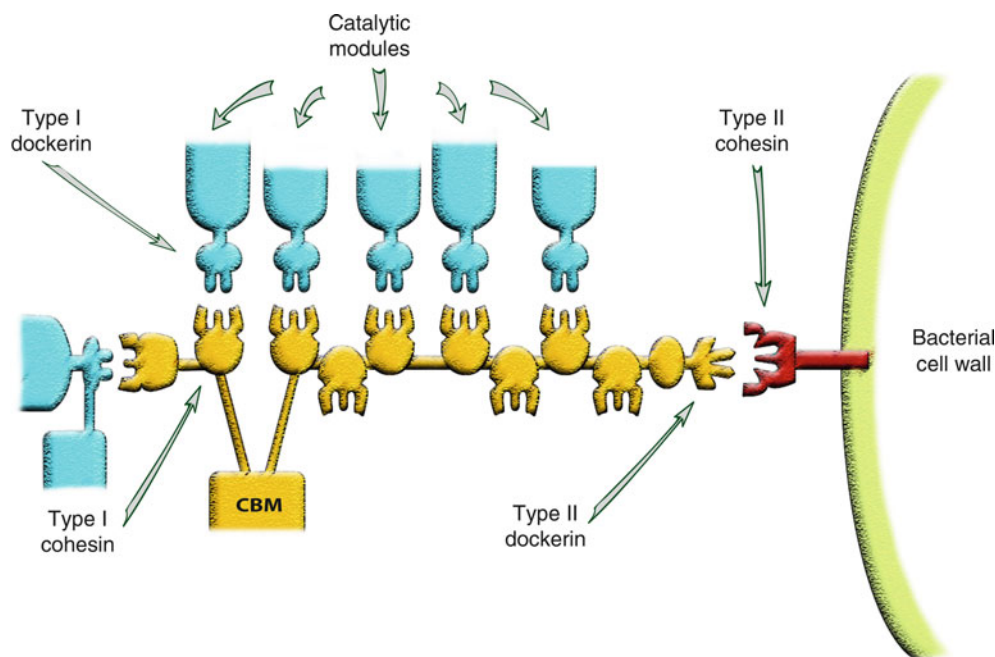

■ Fig. 7.5
Clostridium thermocellum's cellulosome. CBM carbohydrate-binding module (Based on Gilbert 2007)

with approximately 2–6 MDa is composed of a type I containing a protein called CipA and at least nine enzymatic subunits, including hemicellulases and cellulases. The enzymatic subunits contain a dockerin domain that binds specifically to the scaffolding cohesin type I. Moreover, the scaffolding protein has two other domains, a CBM, carbohydrate-binding module, and the type II cohesion module at the C-terminal region that is anchored to the bacterial peptidoglycan layer (► Fig. 7.5). The CBM interacts tightly with crystalline cellulose and, thus, plays a key role in the attachment of the cellulosome to its substrate. The numbers of enzymatic units and cohesion domains are different for other *Clostridium* species, but the overall cellulosomal architecture is very similar (Gilbert 2007).

Other cellulolytic bacterial species are found within the phyla Thermotogae, Proteobacteria, Actinobacteria, Spirochaetes, Firmicutes, Fibrobacteres and Bacteroides (Carere et al. 2008). However, approximately 80 % of the isolated cellulolytic bacteria are found within the phyla Firmicutes and Actinobacteria. The majority of the Gram-positive cellulolytic bacteria are found within Firmicutes and belong to the class Clostridia and the genus *Clostridium*. The capability of producing cellulase is characteristic of a wide variety of genera of bacteria, including *Clostridium*, *Bacillus*, *Zymomonas*, *Streptomyces*, *Pseudomonas*, and *Cellulomonas*. Furthermore, not only can these strains survive the harsh conditions found in the bioconversion process, but they often produce enzymes that are stable under extreme conditions which may be present in the bioconversion process, and this may increase rates of enzymatic hydrolysis, fermentation, and product recovery.

The colonization of a wide variety of environmental and industrial niches by these bacteria provides a valuable source

of cellulolytic strains that are extremely resistant to environmental stresses and presents a high metabolic and ecological diversity (Hough and Danson 1999). These include strains that are thermophilic or psychrophilic, alkaliphilic or acidophilic, and halophilic that can be found under aerobic or anaerobic conditions. For example, *Anaerocellum thermophilum*, described as the most thermophilic species of anaerobic bacterium, is able to grow efficiently on crystalline cellulose (Blumer-Schuetz et al. 2008). Unlike bacteria of the genus *Clostridium*, *A. thermophilum* produces free-acting cellulases. On the other hand, the absence of free-acting and cellulosomal cellulases was reported in bacteria belonging to the archaea domain. Those that live under anaerobic conditions play a major role in the digestion of biomass by herbivores and termites (Schwarz et al. 2004). A number of mesophilic cellulolytic anaerobes have been isolated from soil and sediments, compost, sludge, and anaerobic digesters (Leschine 1995; Pérez et al. 2002). Bacteria of the genus *Streptomyces* are abundant in soil (Chater et al. 2010). In terrestrial habitats, *Streptomyces* are important for the initial decomposition of organic material by their arsenal of lignocellulose-degrading enzymes (Schrempf 2007).

The production of cellulases by bacteria is governed by induction, catabolism repression, or end product inhibition (Kumar et al. 2008). The former mechanism also controls the constitution of cellulosome from *C. thermocellum*. The proteomic maps of the cellulose-bound protein fraction containing the cellulosomes show that the enzymatic subunits vary according to the carbon source used in the culture medium (Raman et al. 2009; Nataf et al. 2010).

Traditional cultivation-based techniques are widely used to prospect cellulolytic bacteria as a source of cellulases for

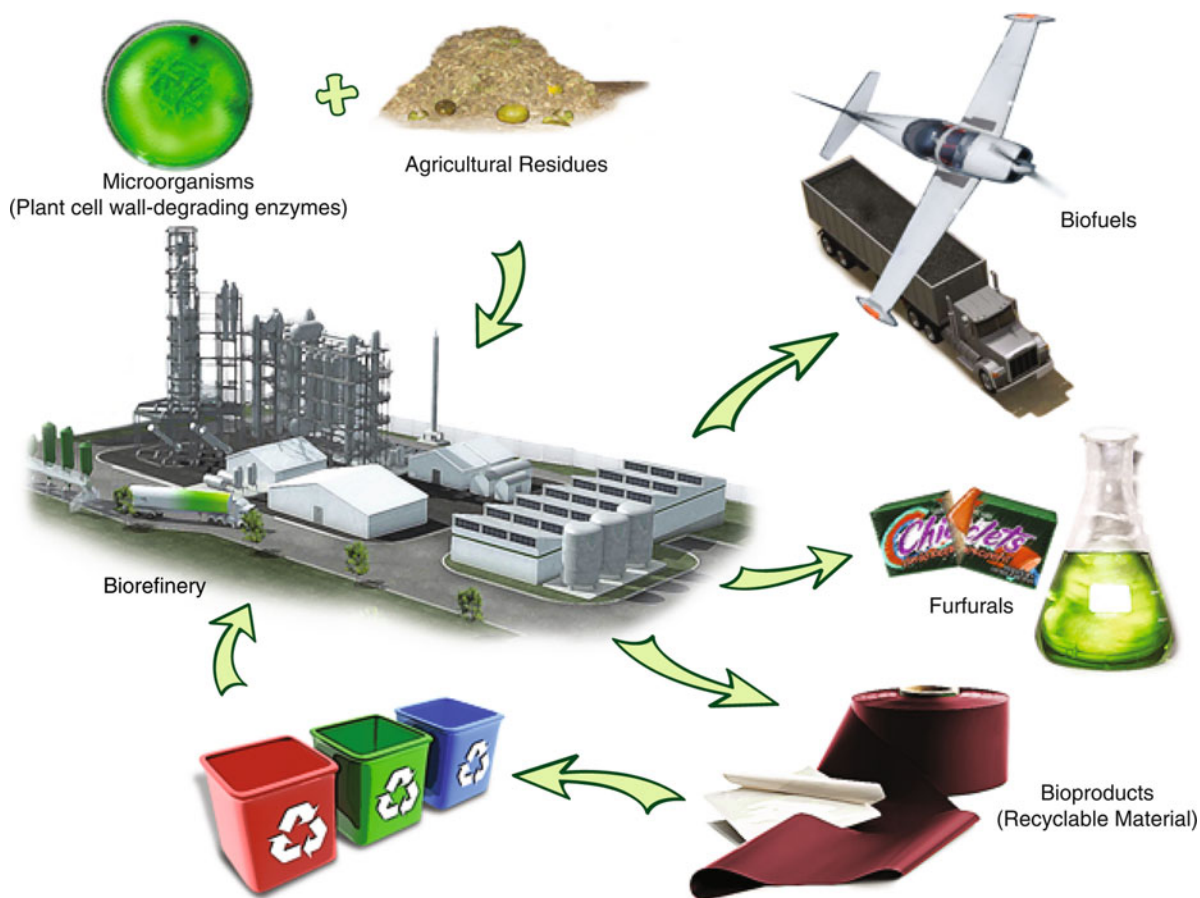

■ Fig. 7.6

A model of a biorefinery as an alternative for bioethanol production (Diagram based on Siqueira and Filho 2010)

industrial applications. However, most of the bacteria are cultivation resistant, thereby reducing the number of species that can be screened in this way (Hess et al. 2011). Therefore, novel approaches have been developed to provide access to the genetic resources of cultivation-resistant bacteria. One important approach is the enrichment of the cultivation medium to obtain the cultivation of resistant species. Novel culture mediums have been developed containing growth supporting factors (GSF) such as culture supernatant and cell-free extracts of other microorganisms and cocultivation with helper bacteria and successfully used to obtain bacteria previously described as cultivation resistant (Joong-Jae et al. 2008). The metagenomic approach is also a promising technique to prospect cellulolytic genes from uncultivable cellulolytic bacteria. This technique is cultivation independent and provides the screening of a set of genomes of a microbial community (Hess et al. 2011).

Biotechnological Applications

Bacterial cellulases have applications in agricultural and industrial processes, including laundry and detergents, textile, food and animal feed, pulp and paper, and biofuel industries

(Sukuruman et al. 2005; Turner et al. 2007). The use of cellulases in industrial processes is becoming increasingly widespread because of their catalytic efficiency, their ability to operate under green conditions, and their ease of production in large quantities through fermentation procedures (Hancock et al. 2006). One of the most important applications of cellulase systems could be in the production of ethanol from renewable lignocellulose (Li et al. 2009; Zhang et al. 2010). ● Figure 7.6 shows an example of a biorefinery for a variety of products, including bioethanol and recyclable materials. In this context, thermostable cellulases are highly desirable; cellulose breakdown is carried out at high temperatures (Turner et al. 2007).

Significant advances have been made toward the use of lignocellulosic residues, including sugarcane bagasse and corn stover, as cellulose sources for the fermentation of glucose to ethanol and production of cellulase by microorganisms (Zaldivar et al. 2001; Merino and Cherry 2007; Neves et al. 2007). The consolidated bioprocessing strategy, based on cellulase production, cellulose hydrolysis, and fermentation in one step, is becoming an alternative approach for the production of low-cost biofuel from lignocellulosic biomass (Lynd et al. 2005; Carere et al. 2008). The main goal of CBP, also referred to as the third-generation biofuel production, is the development of

a single-step conversion process that dramatically reduces the cost and complexity of producing cellulosic ethanol on a commercial scale from a broad variety of nonfood feedstocks. Within this context, native and recombinant cellulolytic strategies have been tested in CBP-developing bacteria (Lynd et al. 2005; Zhang et al. 2010). *B. subtilis* is described as a potential biocommodity-producing bacterium given its ability as a recombinant cellulolytic industrial microorganism. Furthermore, *B. subtilis* has several advantages such as being industrially safe and having a very high-protein-secreting capability. *Zymomonas mobilis*, a facultative anaerobic Gram-negative bacterium, has emerged as an alternative to the use of yeast in ethanol production (Panesar et al. 2006). Comparative attributes for ethanol production by *Zymomonas* and yeast indicate a higher specific rate of sugar uptake and high ethanol yield for *Z. mobilis*. However, the rate of ethanol production and the final ethanol concentration decrease when *Z. mobilis* strains utilize industrial substrates as the carbon source.

In conclusion, a large number of cellulases have been isolated from bacterial sources and used in many industrial applications. Researchers are now focusing on utilizing and improving these enzymes for use in the biofuel and bioproduct industries. Thus, successful development of “third-generation” biofuels depends on a detailed understanding of the mechanisms of action of these enzymes (Carere et al. 2008). Furthermore, cellulase performance could be improved by a number of factors, including increasing the catalytic rate constants and improving the pretreatment technology (Himmel et al. 1999). Other alternatives include the use of strategies based on directed evolution, rational design, and the employment of continuous culture using insoluble cellulosic substrates (Zhang et al. 2006).

Peroxidases

Peroxidases (EC 1.11.1.x) represent a large group of oxidoreductases that catalyze the reduction of hydrogen peroxide in different oxidative reactions and present a set of organic and inorganic substrates as electron donors. These enzymes are classified as heme peroxidases depending on the presence of the heme group at the catalytic site and are separated into two major superfamilies according to their sequence similarity: one includes peroxidases from fungi, plant, and bacteria while the other is represented by the peroxide cyclooxygenase that includes vertebrate enzymes. The superfamily of plant, fungi, and bacterial heme peroxidases includes an evolutionary-related monomeric group of proteins with a molecular weight ranging from 35,000 to 45,000 Da which is then subdivided into three classes, I to III, and also according to their sequence similarities. The bacterial peroxidases are represented in class I characterized by the absence of disulfide bridges, glycosylation, and their association with calcium ion; class II is represented by the fungal lignin peroxidases and manganese peroxidases and class III by plant peroxidases. The heme peroxidases of *Mycobacterium tuberculosis*, *Escherichia coli*, and *Synechocystis* PCC 6803 KatG are

examples of bacterial members inside heme peroxidase class II (Battistuzzi et al. 2010).

The reaction catalyzed by these enzymes is carried out in three consecutive redox steps made up of the redox couples compound I/Fe⁺³, compound I/compound II, and compound II/Fe⁺³. The reaction catalyzed by heme peroxidases is initiated by a two-step reduction of hydrogen peroxide (H₂O₂) to water and concomitantly conversion of the enzyme to the compound I containing an oxyferryl center and organic cationic radical on the heme group. This radical is subsequently reduced by the second molecule of hydrogen peroxide, forming the compound II that maintains the oxyferryl group, and then it is reduced to the ferric state by a second substrate (Battistuzzi et al. 2010).

A novel superfamily of heme peroxidase was recently described, and it presented sequences and structural and reaction characteristics quite different from that explained for the classes I to III of the heme-containing peroxidases. These enzymes were analogs to isoforms previously described for fungi and present dye-decolorizing activity against a set of colorants used industrially in the textile and pharmaceutical industries, and so are designated dye-decolorizing peroxidases (DyP-type peroxidase) (Zubieta et al. 2007). They were described in *Bacteroides thetaiotaomicron* (BtDyP), *Shewanella oneidensis* (TyrA), and *E. coli* (YcdB), but their physiological role is yet unknown. The DyP-type peroxidase from the thermophilic bacteria *Thermobifida fusca* also has activity against other phenolic compounds and aromatic sulfides; however, this activity has not been described for the others members of this superfamily (Zubieta et al. 2007; Bloois et al. 2010).

The bacterial peroxidases are also represented by nonheme and non-selenium proteins different from catalases and glutathione peroxidases and the cysteine-based peroxidases known as peroxiredoxins (Prxs). These enzymes present an important role in antioxidant defenses against peroxide-mediated oxidative damage since they have detoxification ability against organic hydroperoxides, hydrogen peroxide, and peroxyxynitrite. Their oxidative/reductive activity depends on the presence of reactive cysteinyl residues at the active site. During the reaction, the enzyme is oxidized and recycled in a process mediated by NAD (P)H and at least two proteins: thioredoxin reductase (TrxR) and thioredoxin (Trx). Two major catalytic mechanisms were identified; therefore, they can be classified as 1-Cys Prx and 2-Cys Prx, and the second group can be further subdivided into typical 2-Cys Prx and atypical 2-Cys Prx, according to the localization of the additional cysteine involved in catalysis (Poole 2005). Classification based on amino acid sequence similarity, structural motifs, structural elements, and conserved amino acids around the active site has also been used as a parameter to categorize this protein family in three different ways, as proposed by Copley et al. (2004), Trivelli et al. (2003), and Hofmann et al. (2002). The Copley's classification is based on the sequence similarities of the Prx members classified in five classes class 1 to class 5 (Horta et al. 2010). Prxs are widely distributed and are found in the majority of the pathogenic bacteria such as *Xylella fastidiosa*, *P. aeruginosa*, and *Mycobacterium* spp. and are probably used as a primary defense

mechanism against the production of oxidants by the host during infection. In addition, the production of Prxs by pathogenic bacteria has been linked to the virulence (Horta et al. 2010; Trujillo et al. 2006).

Due to its action against industrial dyes, phenolic compounds, and aromatic sulfides, the bacterial DyP-type peroxidases have been studied for their application in the bioremediation of liquid and solid wastes produced by the pharmaceutical, textile, and petrochemical industries and thus contribute to the transformation of polluting compounds to less toxic or innocuous products (Zubieta et al. 2007). The same use is also applied to the heme peroxidases as bioremediation agents to reduce the contamination effects of phenolic compounds, heavy metals, aromatic hydrocarbon, and azo dyes (Garcia-Arellano et al. 2004). In addition, the peroxidases can be used for the development of diagnostic kits and biosensors. Biocatalytic sensors using enzymes as the recognition element are typically easy to use, compact, inexpensive devices, and often with relatively simple designs and do not require expensive instrumentation. Moreover, these sensors can be adapted to automatic clinical laboratorial or industrial analyses. The peroxidases, like others oxidoreductases, are an important biosensor component enabling the monitoring of the concentrations of phenolic pollutants in the environment and other peroxidase substrates in samples from different sources (Ronkainen et al. 2010).

Indeed for this biotechnological application, the genomic analysis of *Amycolatopsis* sp. ATCC 39116 led to the discovery of two new heme proteins that are produced by this bacterium during the growth in the presence of lignocellulosic biomass. These enzymes are similar to the manganese and lignin peroxidases produced by white root filamentous fungi, which are very useful in the industrial breakdown of lignocellulosic biomass for the production of bioethanol. However, these enzymes present a quite different reactivity toward lignin than the fungal partners. They remove the lignin from the substrate and favor the cellulase activities which hydrolyze the raw material producing fermentable sugars. Moreover, several species of soil bacteria have also been reported to produce lignin-degrading or lignolytic-like enzymes such as *Streptomyces viridosporus*, *Streptomyces griseus*, *Streptomyces badius*, *Arthrobacter chlorophenolicus* and *Rhodococcus opacus* (Brown et al. 2011).

Peptidases

Definition and Classification

Peptidases including keratinases are hydrolases able to hydrolyze peptide bonds in proteins and peptides. They are classified using three different approaches: (1) the chemical mechanism of catalysis (based on the catalytic amino acid or metal ion at their active site, represented by serine, cysteine, threonine, aspartic, asparagine, glutamic and metallo-catalytic type), (2) the catalytic reaction (this type of classification depends on the selectivity for the bonds that the peptidases will hydrolyze), and (3) the molecular structure and homology. In this latter approach, amino acid

sequences and three-dimensional structures of the peptidases are analyzed and compared. Figure 7.7 summarizes the current classification of peptidases. The MEROPS database has grouped peptidases into protein species, which are in turn grouped into families, and then into clans. In the Merops (release 8.5), all known peptidases are grouped into 208 families and 52 clans (Rawlings et al. 2010).

The seven catalytic types depend on the nature of the nucleophile in the catalytic reaction. The nucleophile could be either the hydroxyl of a serine or a threonine, the thiol of a cysteine, or the activated water bound either to a metal ion (metallopeptidases) or aspartate, glutamate, and asparagine residues.

In cysteine, serine, and threonine peptidases, the nucleophiles are in the amino acid residue (Cys, Ser, or Thr, respectively) located at the active site from which the class names are derived. The peptidases utilize the nucleophiles and form an acyl intermediate – these peptidases can also readily act as transferases. Aspartic, asparagines, glutamic, and metallopeptidases utilize an activated water molecule as a nucleophile to attack the peptide bond of the substrate. Most of the keratinases are serine and metallopeptidases, but the precise mechanism of keratin degradation is not completely elucidated. Probably keratinase activity is not due to only one enzyme. It is a cooperative system with peptidases and an enzyme disulfide reductase or a reducing agent such as a sulfide as occurs in sulfitolysis (Kunert 1972; Yamamura et al. 2002; Gupta and Ramnani 2006). Figures 7.8 and 7.9 show the keratin degradation mechanism.

Peptidases in the Prokaryotes

Among the prokaryotic organisms, peptidases of seven catalytic types are found. Only one, the glutamic peptidase, has been recently described in prokaryotes in the thermoacidophilic bacteria *Alicyclobacillus* sp. DSM 15716 (Jensen et al. 2010). In the next section, some peptidases from the different catalytic types will be cited below, but the peptidases from prokaryote can be found in MEROPS database (Rawlings et al. 2010).

Aspartic Peptidases

In Merops, the peptidase database, release 9.5, there are 16 families of the aspartic peptidases distributed between vertebrates, fungi, plants, protozoa, viruses, and prokaryotes (Horimoto et al. 2009). Structurally, aspartic peptidases are bilobal enzymes, each lobe contributing with a catalytic Asp residue, with an extended active site cleft localized between the two lobes of the molecule. The presence and position of disulfide bridges are another conserved feature of aspartic peptidases. All or most aspartate peptidases are endopeptidases. In prokaryotes, they are detected in archaea and bacteria. One example is the thermopain, which is a thermostable acid protease from the archaea *Sulfolobus acidocaldarius* (A5 family, EC 3.4.23.42) (Dash et al. 2003). The enzyme shows a broad protein substrate

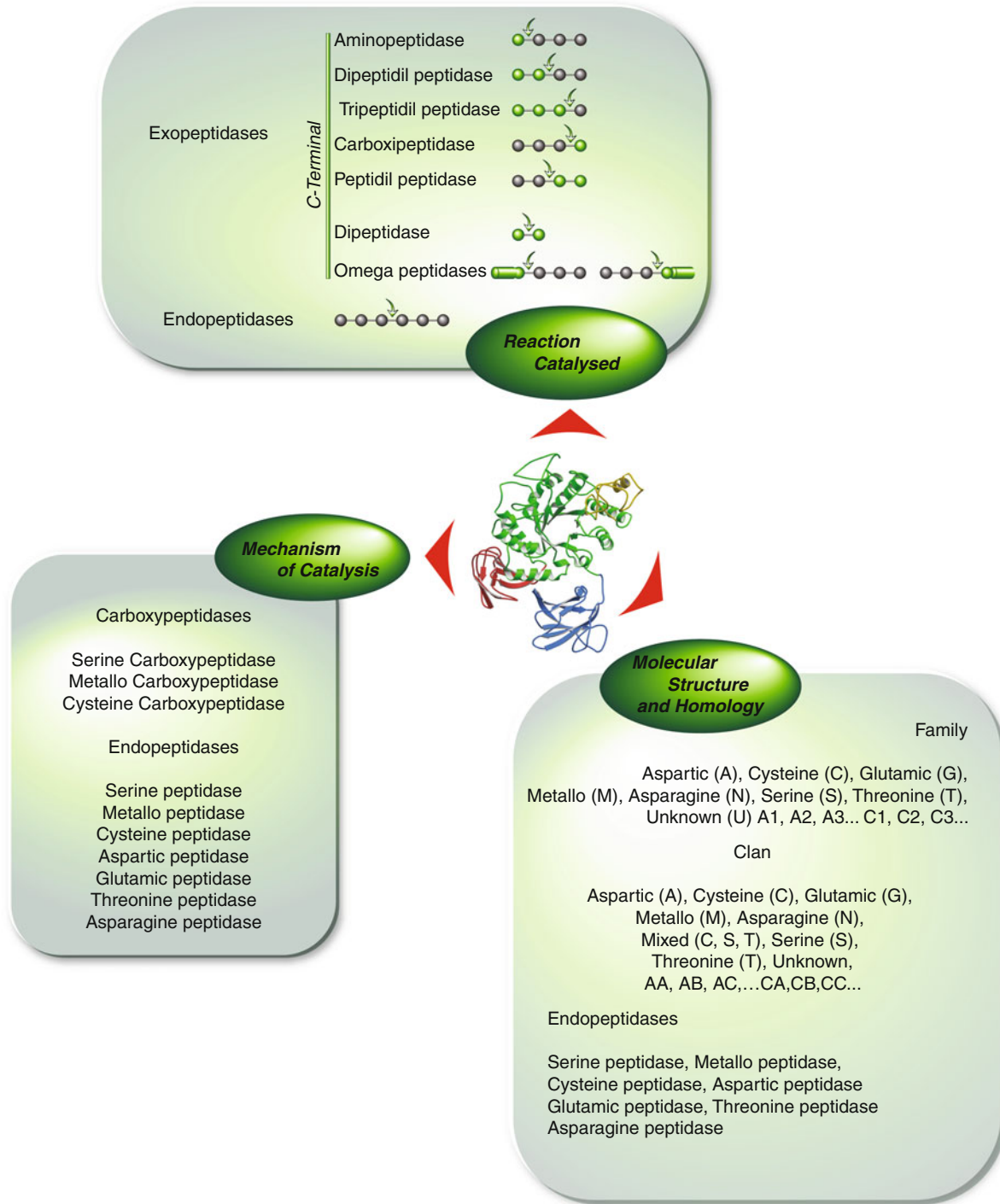
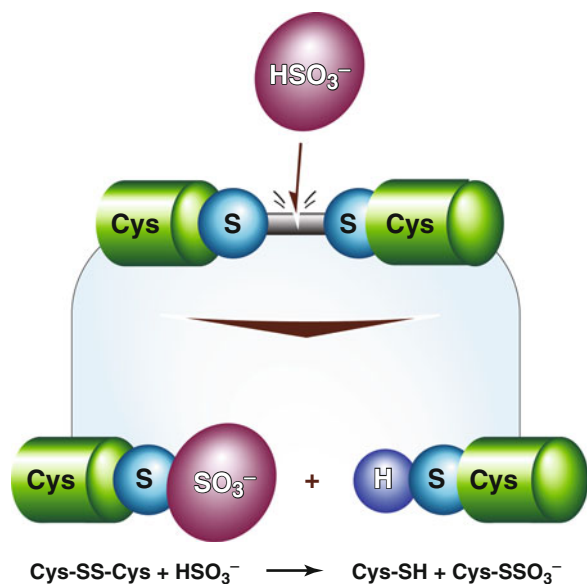

Fig. 7.7 Peptidase classification. Mechanism of catalysis: catalytic site; reaction catalyzed: cleavage site; and molecular structure and homology: amino acid sequences and three-dimensional structures

specificity, it is involved in the supply of nutrients from protein substrates since this bacterium optimally grows in pH 2 at about 70 °C (Fusek et al. 1990; Lin and Tang 1990; Tang and Lin 2004). Other aspartic peptidases include *E. coli* signal peptidase II or lipoprotein signal peptidases (A8 family, EC:3.4.23.36) which

facilitates the secretion of the lipoprotein. Signal peptidases (SPases) remove the targeting signals (i.e., signal peptides) from proteins that are translocated across the bacterial cytoplasmic membrane (Paetzel et al. 2002). Pepsin homologues have been found in the completed genomic sequences of seven



■ Fig. 7.8

Sulfitolysis. The high number of disulfide bonds in the structure of keratin makes it insoluble and resistant to peptidases. Sulfide secreted by the microorganism cleaves the disulfide bonds in the cysteine from keratin allowing its posterior enzymatic degradation. This mechanism was described for the first time by Kunert (1972) working with *dermatophyte* fungi. Currently, this mechanism has been found in several sulfide-secreting bacteria such as *Bacillus* sp. (Ramnani et al. 2005; Suh and Lee 2001)

species of two groups of bacteria: oceanic bacteria and plant symbionts. The Proteobacteria are *Colwellia psychrerythraea*, *Marinomonas* sp. MWYL1, *Shewanella amazonensis*, *Shewanella denitrificans*, *Shewanella loihica*, *Shewanella sediminis*, and *Sinorhizobium medicae*. The bacterial homologues, unlike those from eukaryotes, do not possess signal peptides and would therefore be intracellular acting at neutral pH. No pepsin homologues could be detected in any archaea genome (Rawlings and Bateman 2009). Other aspartic peptidases from prokaryote can be found in the MEROPs database (Rawlings et al. 2010).

Metallopeptidases

Metallopeptidases (EC 3.4.24) are the most diverse of the four main types of protease, with more than 60 families identified to date. In these enzymes, a divalent cation, usually zinc, activates the water molecule. The known metal ligands are His, Glu, Asp, or Lys, and at least one other residue is required for catalysis, which may play an electrophilic role. In the prokaryotes, metallopeptidases are distributed in the bacteria and archaea domains (Rawlings et al. 2010).

The thermolysin family (M4) has been found in *Bacillus thermoproteolyticus*, and this metallopeptidase is the type example of the M4 family. At least 200 sequences belonging to the

M4 family have been described, and among them, other bacteria and archaea metallopeptidases were found (Adekoya and Sylte 2009). This metallopeptidase binds to a single catalytic zinc ion. Other examples are the extracellular elastase of *P. aeruginosa* (Malloy et al. 2005) and aureolysin from *Staphylococcus aureus* (Banbula 1998). Collagenases from *Vibrio* sp. and *Clostridium* sp. both of them of the M9 family are other metallopeptidases described (Dive et al. 1990; Rawlings and Barrett 2004).

Cysteine Peptidases

Cysteine peptidases (EC 3.4.22) are also referred to as thiol peptidases, sulfhydryl peptidases, and cysteinyl peptidases. The catalysis of cysteine peptidases involves the covalent intermediate, thioester (Atkinson et al., 2009). Many pathogens, including bacteria, use cysteine peptidases to evade target organism defense mechanisms. Staphopains A and B from *Staphylococcus aureus* (family C47), gingipains from *Porphyromonas gingivalis* (family C25) and streptopain from *Streptococcus pyogenes* (family C10) are some examples. Furthermore, the growth and proliferation of pathogenic bacteria depend on proteolytic enzymes (Travis et al. 1995; Potempa and Pike 2009). Research labs and the pharmaceutical industry focus on these enzymes as potential targets for the control of bacterial infections (Kantyka et al. 2010). In archaea, the PfpI peptidase from *Pyrococcus furiosus* is the enzyme type of family C56. It is an intracellular cysteine peptidase, characterized by its stability, and is proposed to represent the predominant proteolytic activity of this thermophilic archaeobacterium (Du et al. 2000).

Serine Peptidase

Serine peptidases constitute the largest group of peptidases and the trypsin-like peptidases of family S1 of clan PA are the most abundant among the serine peptidases. Over 18,000 serine proteases are grouped into 114 clans and 48 families. They are found in eukaryotes, prokaryotes (archaea and bacteria), and viruses (Polgar 2005). The catalytic mechanism of serine peptidases involves a covalent intermediate ester. Several serine peptidases have industrial applications such as subtilisin Carlsberg isolated from *B. licheniformis* and others. One of the largest markets for industrial peptidases is the detergent industry (Saeki et al. 2007). The success of subtilisins is based on several factors, including their high stability and relatively low substrate specificity. Another important factor is their production as extracellular enzymes facilitating the separation of the enzyme from the biomass and other downstream processing steps (Maurer 2004). The *Bacillus* genus is the major bacteria, and at present, 15 different enzyme molecules are used in detergents worldwide. These enzymes originate from *B. amyloliquefaciens*, *B. licheniformis*, *Bacillus clausii*, *Bacillus lentus*, *Bacillus alcalophilus*, and *Bacillus halodurans* (Siezen and Leunissen 1997; Betzel et al. 1992).

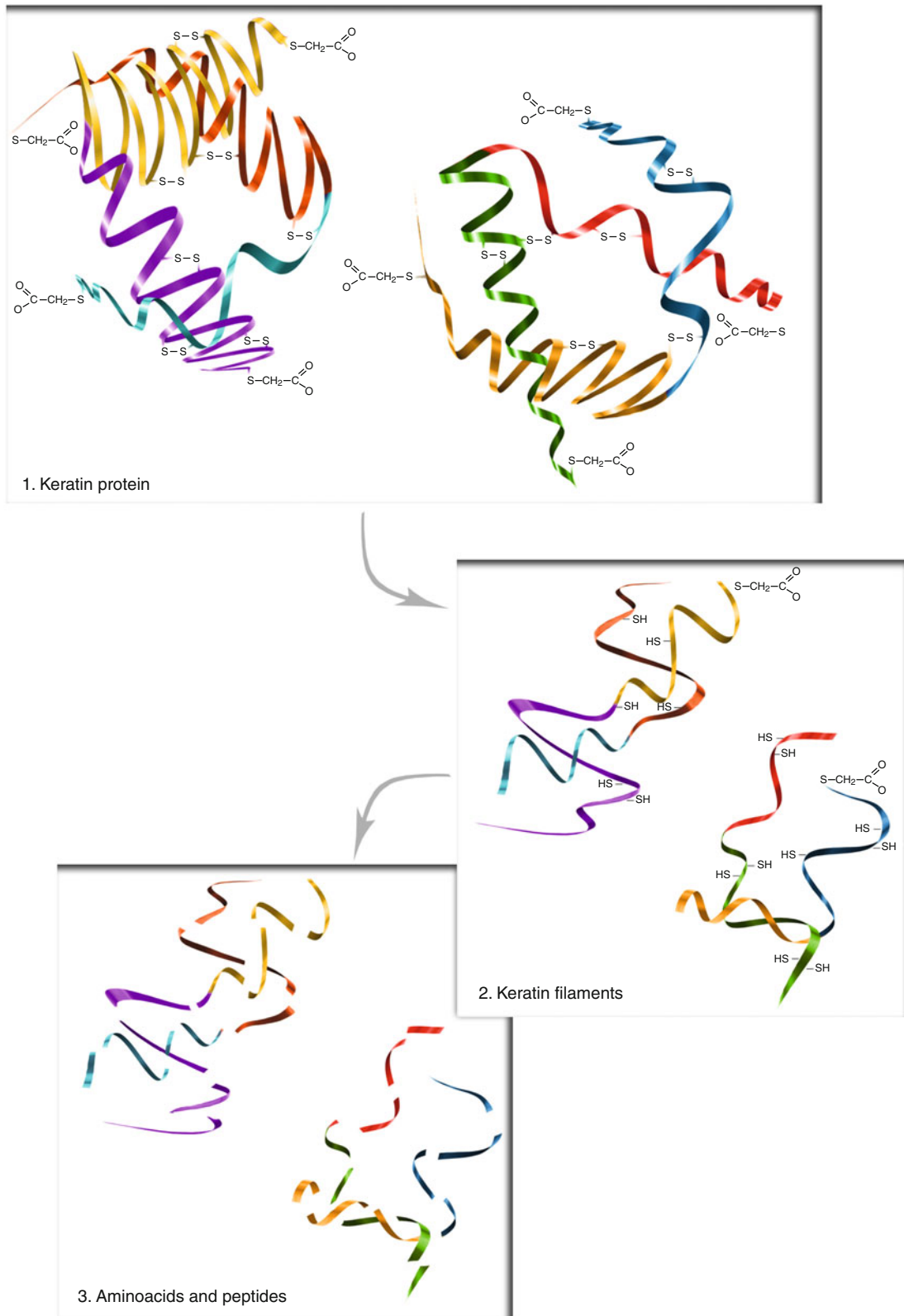

■ Fig. 7.9

Cooperative mechanism: disulfide reductase (disulfide bond reducing) and peptidases (cleaving peptide bonds in keratin). This mechanism was described by Yamamura et al. (2002) in *Stenotrophomonas* sp. None of these enzymes showed keratinolytic activity independently and the cooperative action of the two enzymes results in the effective degradation of keratin. Extracellular peptidases acted on the dissociated polymers, hydrolyzing them into peptides/amino acids

Asparagine Peptidases

Recently added to the MEROPS database, asparagine peptidases have ten families distributed in six clans and have been detected in cyanobacterium *Synechocystis* sp. PCC 6803 (family N10), in *Yersinia pseudotuberculosis* (YscUprotein, family N6), and in *E. coli* (family N4, Tsh-associated self-cleaving domain). In the asparagine peptidases, the nucleophile is asparagine and all are self-processing endopeptidases (Rawlings et al. 2010).

Proteasome

Proteasomes are multisubunit peptidases found in all eukaryotes and archaea and some bacteria. The 20 S proteasome is found only in actinomycetales. Prokaryotic 20 S proteasome cores are self-compartmentalized peptidases composed of 14 α -subunits and 14 β -subunits, with the N-terminal threonines of the β -subunits providing the protease activity. Core particles from archaea and bacteria are simpler structures with homoheptameric rings of catalytic β -subunits flanked by homoheptameric rings of α -subunits. In bacteria, proteasomes are evolved in protein turnover, but in archaea, their function is unknown. Proteasomes are threonine peptidases (Darwin 2009; Murata et al. 2009).

Biological Roles of Peptidases

Peptidases have been widely studied, and a variety of biological functions and processes depend on their activity. They catalyze highly specific reactions producing new protein products; they regulate the fate, localization, and activity of many proteins, modulating protein-protein interactions in biological systems and contributing to the processing of cellular information (López-Otín and Matrisian 2007). They also play important roles in the pathogenesis of diseases, in the inactivation of host immune defense mediators, in the processing of host or parasite surface proteins for invasion of host cells, as well as in the digestion of host proteins for nutrition. Peptidases are potential drug targets for microbial diseases and are a research area for the pharmaceutical industry (Ilies et al. 2003; Santos et al. 2003; Vermelho et al. 2007; Rodrigues et al. 2010).

Many bacteria express a variety of peptidases with a different degree of specificity ranging from nonspecific to specific enzymes. Some of them degraded proteins involved in human innate immunity (for review, see Potempa and Pike 2009). An example is the metallopeptidase aureolysin from *Staphylococcus aureus* that cleaves and inactivates LL-37 (Sieprawska-Lupa et al. 2004).

In prokaryote, some extracellular peptidases produced by various pathogens are considered virulence factors. These proteins are not produced constitutively but are regulated in response to various environmental and cellular stimuli (Władyka and Pustelny 2008). *Porphyromonas gingivalis*, the major etiologic agent of periodontitis, produces several virulence factors, including peptidases.

Lys-gingipain, a cysteine proteinase, is the main endopeptidase produced by *P. gingivalis* (Grenier and Tanabe 2010). *Vibrio cholerae* O1, the causative agent of epidemic cholera, secretes 32-kDa zinc-containing hemagglutinin (HAP), the peptidases PrtV, and a 59-kDa serine peptidases, all of which are related to the pathogenicity (Syngkon et al. 2010). Peptidases appear to be critical for cell cycle development in *Caulobacter crescentus*. Each cell division cycle involves cellular events with extensive protein degradation involving peptidases (Grunenfelder et al. 2001; Gottesman 2003).

P. aeruginosa is an opportunistic pathogen typically associated with long-term infection in patients undergoing treatment for cancer or burn wounds, trauma, and those with cystic fibrosis (Govan and Deretic 1996). It is also a leading pathogen in nosocomial pneumonia. *P. aeruginosa* secretes a number of peptidases including various alkaline proteases and elastases which degrade surfactant proteins and results in a reduction in pulmonary surfactant host defense and biophysical functions (Potvin et al. 2003; Malloy et al. 2005).

Collagenases have been characterized in *Clostridium* sp. and other bacteria, and besides their role in pathogenicity, they have promising industrial applications based on diverse biological functions of collagen (Watanabe 2004).

Another important function is that peptidases perform some of the most important posttranslational processing events leading to the activation or inactivation of other proteins, including other enzymes (Rawlings and Bateman 2009).

Biotechnological Applications

Bacterial peptidases have found several applications worldwide, for example, as additives for laundry detergents. In detergents, several serine peptidases of *Bacillus* sp. have been used (Maurer 2004; Saeki et al. 2007). In dermatology, keratinases have been demonstrated to enhance unguinal drug permeation in topical therapy of nail diseases. The use of drugs is limited due to their low permeability through the nail plate (Mohorcic et al. 2007). Bacterial collagenases have a direct therapeutic use in wound healing (Sank et al. 1989). Furthermore, they can tenderize meat by digesting collagens in the food industry (Takeuchi et al. 1992). In bacteria, cysteine, serine, and metallopeptidases with activity against collagen are found. But in collagenolytic peptidases from bacteria, metallopeptidases, such as the collagenases produced by *Clostridium histolyticum* and *Bacillus cereus* (Watanabe 2004), are the most frequent. Keratinases have been used to process keratin waste, recycling them into peptides for feeds and fertilizers (Kornilowicz-Kowalska and Justyna 2011). Recently, a pesticide effect against root-knot nematodes, specifically *Meloidogyne incognita*, with a keratinase isolated from *Bacillus* sp. was reported (Yu et al. 2011).

In the food industry, peptidases have several applications (Olempska-Beer et al. 2006). The bitterness found in protein hydrolysates has been classically associated with the release of peptides containing hydrophobic amino acid residues

Table 7.1

Commercial peptidases and their applications

Enzyme	Class	Commercial name	Bacteria	Application	Reference
Keratinase	Serine	Valkerase (BioResource International)	<i>Bacillus</i> sp.	Poultry feather meal	Lin et al. (1997), Wang et al. (2006)
Keratinase	Serine	Versazyme (BioResource International)	<i>B. licheniformis</i>	Animal feed	Wang et al. (2006)
Keratinase	Serine	Pure100 Keratinase (Proteos Biotech)	Recombinant <i>B. licheniformis</i> (PwD) and produced in <i>E. coli</i>	Acne, psoriasis Depilation Preparation of vaccine for dermatophytosis therapy Nail treatment Epithelium regeneration Cosmetic	Vignardet et al. (2001), Friedrich et al. (2005), Gradisar et al. (2005), Mohorcic et al. (2007), Chao et al. (2007)
				Degradation of prion and prion-like proteins	Wang et al. (2005), Yoshioka et al. (2007)
				Animal feed	Suzuki et al. (2006)
Peptidase	Serine	RONOZYME ProAct (Novozyme)	Genetically modified strain of <i>B. licheniformis</i>	Animal feed	Caloni (2009)
Keratinase	Metallo	Arazyme (Insect Biotech Co)	<i>Serratia</i> <i>proteamaculans</i> HY-3	Cosmetic Detergent Animal feed Textile (leather depilation)	Kwak et al. (2007)
Peptidase	Serine (subtilisins)	Alcalase (Novozyme)	<i>B. licheniformis</i>	Detergent	Maurer (2004), Saeki et al. (2007)
		Savinases (Novozyme)	<i>B. clausii</i>		
		Properase TM (Genencor)	<i>B. alcalophilus</i> PB92		
		BLAP Xb (Henkel)	<i>B. lentus</i>		
Peptidase	Metallo	Collagenase SANTYL [®] Ointment (Santyl)	<i>Clostridium</i> <i>histolyticum</i>	Wound healing Pharmaceutical	Metzmacher et al. (2007)

(Ney 1979). Significant reductions in bitterness have been observed after peptidase treatment of food. The peptidases used are exopeptidases including amino- and carboxypeptidases, which cleave hydrophobic amino acid residues (Saha and Hayashi 2001; Raksakulthai and Haard 2003; FitzGerald and O’Cuinn 2006). Thermolysin is used as a peptide and ester synthetase in the production of the artificial sweetener aspartame (Ager et al. 1998). Table 7.1 summarizes some commercial peptidases and their applications.

Transglutaminases

Definition and Catalyzed Reactions

Transglutaminases (EC 2.3.2.13, TG, TGase, protein-glutamine γ -glutamyl-transferase) are a group of intracellular and

extracellular enzymes that catalyze the posttranslational modification of proteins by the formation of an isopeptide bond. TGase catalyzes the acyl-transfer reaction between the γ -carboxamide group of a peptide-bound glutamine residue and a primary amine. In this reaction, the glutamine side chain serves as the acyl donor and the primary amine functions as the acceptor (Fig. 7.10a). As a result a covalent bond between the two substrates is formed and ammonia is released. In most cases described, the primary amine is the ϵ -amino group of a lysine residue, and the reaction results in the formation of ϵ -(γ -glutamyl) lysine linkages (Fig. 7.10b). When primary amines are not available, water can function as the acyl group acceptor, with the consequent deamidation of the glutamine residue (Fig. 7.10c). This enzyme nonspecifically polymerizes proteins, either intra- or intermolecularly, creating proteins with novel properties and making them highly resistant to proteolytic degradation (Folk 1980).

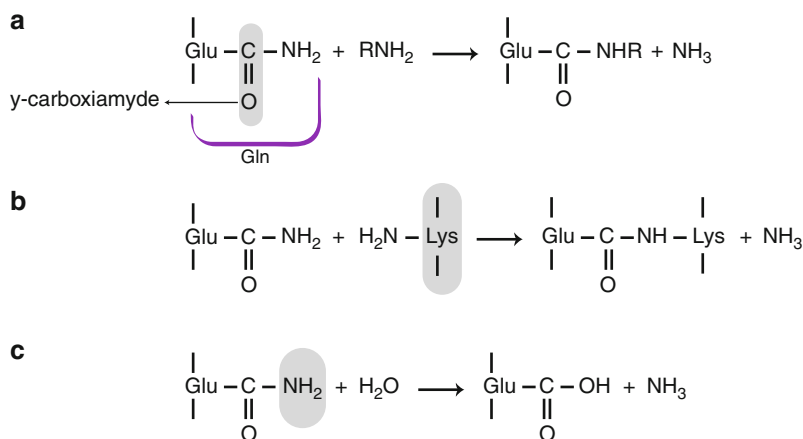

■ Fig. 7.10

Transglutaminase reactions. (a) Acyl transfer. (b) Cross-linking of Glu and Lys residues in proteins or peptides. (c) Deamidation

Microbial TGases (MTGase)

TGases or homologues are widely distributed in nature and are found in humans, plants (Serafini-Fracassini and Del Duca 2008), invertebrates (Singh and Mehta 1994), lower vertebrates (Zhang and Masui 1997), and microorganisms such as archaea (Makarova et al. 1999), bacteria (Yokoyama and Kikuchi 2004), and yeasts (Ruiz-Herrera et al. 1995). The first characterized microbial transglutaminase was that of the actinomycete *Streptomyces mobaraensis* (previously termed *Streptovorticillium mobaraensis*). The enzyme was isolated from the culture medium and produced a Ca^{2+} -independent TGase (Ando et al. 1989). Recently, the crystal structure of the MTGase zymogen from *Streptomyces mobaraense* was determined at 1.9 Å resolution based on the crystal structure of the mature MTGase. The enzyme is secreted as a zymogen with an additional prosequence that consists of 45 amino acid residues at the N terminus, and the enzyme becomes active only after proteolytic cleavage of the prosequence. The structures of the zymogen and the mature TGase are similar, except for the prosequence region (Kashiwagi et al. 2002; Yang et al. 2011). TGase has been detected in various *Bacillus* spp. including the *B. subtilis* (Plácido et al. 2008) and a *Bacillus circulans* from the Amazon (Volken de Souza et al. 2009). ● Table 7.2 summarizes the distribution of a superfamily of proteins homologous to eukaryotic transglutaminases detected using computer analysis and profiles generated by the PSI-BLAST program. The members of the superfamily are found in archaea and bacteria and were detected also in eukaryotes, such as two yeast species and in the nematode *Caenorhabditis elegans* (Makarova et al. 1999). TGases from *Micrococcus* sp., *Clostridium* sp., and *B. subtilis* are registered as patents (Sano et al. 1998; Kobayashi et al. 1999, 2002).

Role of Microbial Transglutaminase

TGases are involved in many physiological functions such as blood clotting, wound healing, formation of isopeptide bonds

in multilayered epithelium, stiffening of the erythrocyte membrane in vertebrates, stabilization of photosynthetic complexes in the chloroplast, modification of cytoskeletal proteins, abiotic and biotic stresses, aging, and programmed cell death in plants (Eckert et al. 2005; Yang et al. 2011). They are also involved in a variety of protein modifications associated with animal development and pathological processes (Muszbek et al. 1996).

In microbiology, these enzymes have been used in many biotechnological applications, but their biological roles need to be studied in more depth. The cytotoxic necrotizing factor 1 (CNF1) from *E. coli* and the dermonecrotic toxin from *Bordetella pertussis*, possess transglutaminase activity which are essential for the deamination of a glutamine in animal GTPases (Horiguchi et al. 1997; Schmidt et al. 1998). A family of bacterial transglutaminase-like cysteine proteinases (BTLCPs) has been described. Assignment of the BTLCP family to the superfamily of transglutaminase-like enzymes suggests a general role for BTLCP proteins in protein modification, although the identity of both the type of modification and the protein substrates remain to be determined. BTLCP representatives with similar genomic neighborhoods exist in all classes of proteobacteria (Ginalski et al. 2004). Transglutaminase from *S. mobaraense* (TGase) was found to facilitate selective cross-linking of bacteriorhodopsin (BR) in purple membrane. BR may act as a glutamine donor as well as a lysine donor for TGase (Seitz et al. 2001). The relation between cell sporulation and TGase production has been well established for *B. subtilis*. Nutrient limitations will trigger *B. subtilis* sporulation. In this process, TGase has a role in the cross-linking of proteins such as GerQ to generate high-molecular-mass proteins involved in the assembly of the spore coating (Ragkousi and Setlow 2004). This enzyme forms an $-\gamma$ -glutamyl lysine isopeptide bond between a lysine donor from one protein and a glutamine acceptor from another protein. GerQ is a lysine donor and any one of the three lysine residues near the amino terminus of the protein (K2, K4, or K5) is necessary to form the cross-links with binding partners in the spore coat (Monroe and Setlow 2006).

■ Table 7.2

A superfamily of proteins homologous to eukaryotic transglutaminases detected by computer analysis using profiles generated by the PSI-BLAST program (Based on Makarova et al. 1999)

Family	Archaea	Bacteria	Yeast	Nematodes	Mammal
1					<i>Homo sapiens</i>
2	–	<i>Bordetella</i> , <i>Synechocystis</i> sp.	<i>Schizosaccharomyces pombe</i> , <i>S. cerevisiae</i>	<i>Caenorhabditis elegans</i>	
3	<i>Methanococcus jannaschii</i> , <i>Pyrococcus horikoshii</i> , <i>Archaeoglobus fulgidus</i>	–	–	–	–
4	–	<i>M. tuberculosis</i> , <i>Aquifex</i> <i>aeolicus</i> , <i>Haemophilus influenza</i>	–	–	–
5	–	<i>Synechocystis</i> sp., <i>M. tuberculosis</i>	–	–	–
6	<i>Methanobacterium</i> <i>thermoautotrophicus</i> , <i>Sulfolobus</i>	–	–	–	–
7	<i>Archaeoglobus fulgidus</i> , <i>Pyrococcus horikoshii</i>	<i>B. subtilis</i> , <i>Synechocystis</i> sp., <i>Aquifex aeolicus</i>	<i>S. cerevisiae</i>	–	–

Biotechnological Applications

In the past, guinea pig liver, a nonmicrobial source of TGase, was the only commercial transglutaminase. The complex separation and purification process for obtaining TGase tissue have resulted in an extremely high price for this enzyme. However, since the early 1990s, many microbial transglutaminase-producing strains have been found. Biotechnological research focusing on the production of microbial TGases, along with downstream processing developments and improved fermentation processes, has reduced the cost and increased the productivity and applications for these enzymes. Currently, they are applied in the food, pharmaceuticals, and textiles industries among others (Yokoyama and Kikuchi 2004).

One approach used for microbial transglutaminase production is to screen TGase-producing microorganisms and produce the enzyme by fermentation technology or obtain the enzyme by means of genetic manipulation using host microorganisms such as *E. coli*, *Bacillus* spp., yeast, or *Aspergillus* spp. (Yu et al. 2008). The secretion of TGase in an enzymatically active form by methylotrophic yeasts (as expression hosts) required a pro-peptide (Yurimoto et al. 2004). The secretion of *Streptomyces mobaraensis* transglutaminase by *Corynebacterium glutamicum* ATCC13869 (formerly classified as *Brevibacterium lactofermentum*) has been described (Date et al. 2003).

TGase is used in the food industry as a natural biological glue, binding meat and fish, and in gelled food products such as jelly, yogurt, and cheese improving the texture (Orenzen and Schlimme 1998; Griffin et al. 2002). The enzyme has the ability to

reconstitute small pieces of meat into a “steak” (Zhu and Tramper 2008). In the case of sausages, hams, and other meat products, the effect of adding TG is improved texture with higher breaking strength or firmness. In cheese, TGase treatment of milk results in an increase in curd yield, a less dry texture, and a reduced whey separation. In yogurt, milk treated with TGase shows an increase in firmness and viscosity and reduced syneresis (Arrizubieta 2007; Kuraishi et al. 2001). The enzyme has applications in bakery. Gluten, the protein of wheat flour, can be cross-linked by TGase reinforcing the protein network structure and changing the viscoelastic properties of the dough (Larre et al. 2000).

Polymer hydrogels have been extensively investigated as materials useful for drug delivery, tissue repair, and tissue engineering, and protein cross-linking enzymes, such as transglutaminase, could be used (Hu and Messersmith 2003). McDermott et al. (2004) were the first to convert gelatin solutions into hydrogels using transglutaminase as a catalyst.

In leather processing, materials have to be introduced between the fibers to smoothen any irregularities on the leather surface. Casein cross-linked with transglutaminase can be used effectively as a filling material (Taylor et al. 2007).

Cortez et al. (2004) were among the first to report the use of transglutaminases for wool processing in the textile industry. The enzyme was either directly used with wool or was used after protease treatment. Transglutaminase-treated wool showed an increase in fabric strength of up to 25 % compared to the control. Using silk proteins, TGase mediated their grafting onto wool fabrics leading to improved physical and mechanical properties (Cortez et al. 2007).

Transglutaminase from a variant of *Streptovorticillium mobaraense* was used to immobilize biomolecules on electrodes acting as a biosensor (Josten et al. 1999).

Medical applications include the use of FXIII in blood clotting products to control bleeding during surgery and as a general tissue adhesive. The use of putrescine as a TGase inhibitor in the treatment of scars tissue was patented. Hypertrophic scarring occurs in a significant number of patients following surgery or serious burns. A higher percentage of type III collagen due to elevated levels of TGase activity is associated with these scars (Dolynchuk and Bowness 1999). Due to the role of TGase in the epidermal tissue differentiation, these enzymes could be used in cosmetic preparations and the process was registered as a patent. Topical preparations consisting of TGase and one or more of the corneocyte proteins are proposed to form a protective layer on the surface of hair, skin, and nails (Green and Dijan 1996).

Mireya Santos and Torné (2009) described 20 patents on different TGase codifying genes and 63 patents about their industrial applications.

The Importance and Prospective Market of Industrial and Specialty Enzymes

Introduction

The enzyme market is divided in two main segments: industrial enzymes and specialty enzymes. The industrial enzyme market is divided into three segments: technical enzymes (cleaning products, textile and leather processing, biofuels, and paper and cellulose industry), food and beverage processing enzymes, and animal feed additive enzymes. The industrial enzyme preparations are, in many cases, formulations with different activities according to their use. The specialty enzyme market is divided into four segments: therapeutic enzymes, diagnostic enzymes, enzymes used in fine chemistry, and enzymes used in research. Specialty enzymes need to be highly purified and therefore have a higher price.

The demand for industrial enzymes in mature economies such as the USA, Western Europe, Japan, and Canada has been fairly stable in recent times, while the developing economies of South America, Asia Pacific, Eastern Europe, Africa, and Middle East regions have emerged as the fastest growing markets. Europe followed by the USA commands a major share of the world's industrial enzyme market. On the other hand, Asia Pacific is prompt to register the fastest compound annual growth rate (CAGR). The world enzyme market that was estimated to be worth US \$5 billion in 2009 has likely risen since then as the worldwide enzyme demand is predicted to raise 6.3 % annually through 2013. This increase is chiefly due to the increased demand of industrial enzymes for the production of animal feed, detergent, textile, and ethanol and of specialty enzymes for the pharmaceutical and cosmetics companies. Improved access to medical care facilities as well as services in various developing regions and the urge to achieve universal health care in a few of the mature regions such as the USA has

likely bolstered the demand for diagnostic as well as pharmaceutical enzymes.

The market for industrial enzymes is estimated in 60 % of the world enzyme market and is forecasted to reach US \$4 billion by 2015, while the technical enzyme segment accounts for a market of US \$1 billion of which 30 % corresponds to cleaning enzymes. The market for specialty enzymes was estimated as being US \$2 billion in 2009 which represented 40 % of the world enzyme market and is predicted to rise 7.9 % annually reaching a total of US \$3 billion in 2014 (43 % of the global market).

Figures regarding the international enzyme market, which were referred to in this section, were taken from Freedonia (2005), Freedonia (2009), and Global Industry Analysts (2011).

Industrial Enzymes

A key factor driving market growth is linked to new enzyme technologies endeavoring to enhance cost efficiency and productivity. Market growth is also related to the growing interest among consumers to substitute petrochemical products for those obtained from renewable materials and via an enzymatic route that, besides presenting a superior quality, bears a much lower environmental impact.

The development of novel and superior performing products and rapid advances in the technology could enable industrial enzyme manufacturers to cash in on the vast untapped potential in the market. Sectors such as ethanol production from lignocelluloses have succeeded in drawing significant attention from investors and are self-sufficient in undertaking new product development activities and in launching novel and unique products on the market, thus offering new opportunities for the industrial enzyme manufacturers.

The market leaders in enzymes are proteases and amylases which account for 25 % and 15 % of the industrial enzyme market, respectively. Proteases constitute the largest product segment in the global industrial enzyme market. Growth-wise, the carbohydrase market, which includes amylases, cellulases, and xylanases, is projected to be the fastest growing product segment, with a CAGR of more than 7.0 % through 2013. Lipases are another major product in the global industrial enzyme market with high growth potential. In terms of end use, food and feed are the largest segments for industrial enzymes. Developing regions are expected to emerge as the fastest growing consumers of industrial enzymes for feed applications, where the enzyme phytase plays a central role, in response to the increase in per capita income that would continue to drive the demand for meat.

Considering *food and beverage* enzymes, the successful application of enzymes such as amylases, peptidases, and glucose isomerase has been paving the way for the continuous and above average growth of these enzyme segments that have also been fostered by new applications for bread and dairy products. Enzymes for starch and sugar processing account for 43.7 % of the market, from which 90 % is channeled for the production of high-fructose syrups. Innovation in this sector has been related to enzyme production by genetically modified organisms

(GMO). However, controversy has been hindering the use of GMO enzymes in the bakery industry.

The *cleaning enzymatic product* sector has been fast evolving and highly competitive in response to market pressure. The multienzymatic formulations are very effective to break down organic material, which is enhanced by enzymatic presoaking. The use of enzymatic products has evolved from its earlier application in washing machines to the more specialized cleaning of surgical instruments. Moreover, enzymes are 100 % biodegradable and as such offer a low environmental impact in comparison to the use of the chemical detergents. The main enzymes which are used in the detergent industry are proteases, lipases, amylases, and cellulases (Qing and Zhang 2002).

The use of enzymes in the *feed industry* is growing due to its effect on increasing the feed nutritional value and by extension on the faster growth of poultry and swine. Other advantages include the increasing cost of the traditional feed supplies and the decrease on environmental contamination with phosphate, nitrogen, copper, and zinc. However, there are concerns regarding the enzyme cost and stability besides its low catalytic activity in the formulated feed. The main enzymes which are used in the feed industry are phytases, xylanases, proteases, and amylases (Pariza and Cook 2010).

The *textile industry*, whose global market is worth over US \$700 billion, has been pushed toward innovation to attain better quality products. Furthermore, the increasing demand to reduce pollution caused by the textile industry has fueled biotechnological advances whereby harsh chemicals have been replaced by enzymes for processing of fibers and clothes. In this framework, the use of enzymes evolved for several important wet-processing applications such as de-sizing, bio-polishing, denim finishing, bleach cleanup, bio-scouring, and dewooling, besides improving the softness of fabrics and clothes. Moreover, the use of enzymes, besides decreasing the chemical load and the damage to the garments and machinery, allows a lower energy and water consumption. The main enzymes which are used in the textile industry are cellulases, either acid or neutral, thermostable bacterial amylases, peroxidases, catalases, and pectinases.

The global demand for *liquid biofuels* more than tripled between 2000 and 2007, indisputably showing an increasing trend toward the use of fuels derived from plant feed stocks, which are renewable. Plant-derived materials present different substrates, for example, sugars, starch, lignocellulose, and oils, that can be processed to obtain the target products. The rise in demand has been caused by oil prices, the need to reduce oil imports, energy supply, security issues, environmental concerns, and greenhouse gas mitigation (FAOSTAT, <http://faostat.fao.org/site/567/default.aspx#ancor>) (SIMS et al. 2008). This scenario has led to a remarkable increase in the production of starch derived ethanol in the USA which increased from 18 billion liters in 2006 to 51 billion liters in 2011 (Renewable Fuels Association 2011; Hettinga et al. 2009). As the starch ethanol industry includes an enzyme-based amylolytic step, it is in good reason to assume that the amylase market linked to starch ethanol production increased over twofold in the last 5 years. The

demand for liquid fuels is also pushing toward the development of ethanol production technology from diverse lignocellulosic materials which will include a cellulolytic and xylanolytic step performed by cellulases, beta-glucosidase, and hemicellulases, whose market will increase enormously upon the deployment of this technology. Considering the production of biodiesel from vegetal oils and animal fat, the replacement of the present chemical route by a biotechnological one, based on the use of lipases, would significantly increase the lipase market.

The *pulp and paper industry* offers a huge potential for the cellulase and xylanase markets provided the necessary enzyme cost is met so that enzymes can be used to substitute chlorine and hydrogen peroxide in the bleaching step and alkali and acids for cleaning equipment. There is also potential for enzymatic deinking, a process to remove printing ink from waste paper allowing this material to be recycled. Although the noteworthy environmental impact of the paper industry has led to significant changes in this industry's profile, concerning the use of harsh chemicals, the expected shift toward a biotechnology-based industry is still on hold and dependent on the relevant costs of the biocatalysts.

Specialty Enzymes

The *use of therapeutic enzymes* corresponded, in 2004, to 38.4 % of the total specialty enzyme consumption and it is forecasted to reach 47.2 % in 2014 whereby the market for enzymes used in replacement therapy (ERT) is expected to reach over 50 % of the total pharmaceutical enzymes. ERT is a medical treatment replacing an enzyme in patients in whom that particular enzyme is deficient or absent as in the Gaucher disease, Fabry disease, mucopolysaccharidoses (MPS I and MPS VI), and glycogen storage disease type II, among others. Growth-wise, the USA consumption is the highest in the world making up for the decreasing demand for ERT in Europe. Examples of other uses for therapeutic enzymes include the following: as a digestive aid (usually a mixture of plant-derived enzymes for protein, fat, and carbohydrate digestion), as an anti-inflammatory agent (selected peptidases), for cancer treatment (bacterial asparaginase for leukemia), for treatment for cystic fibrosis (aerosolized enzyme that thins the mucus and digestive enzymes), and as a thrombolytic drug (streptokinase, urokinase). The forecasted market increase for therapeutic enzymes is also due to the advancement in the field of therapeutic enzyme formulations for improved lifetime, stability, targeting, and decreased antigenicity. The use of recombinant DNA technology for the cloning and expression of relevant therapeutic enzymes in accordance to the pharmaceutical industry needs was of paramount importance for the market increase.

The market for *diagnostic enzymes* can be divided into three main segments: analytical enzymes, enzymes for immunoassays, and enzymes used for clinical diagnostic of diseases (Goldberg 2005; Murooka and Yamashita 2001). Polymerase and nuclease enzymes stand out among the diagnostic enzymes accounting for 45 % of the market demand and where the USA is the highest consumer.

The *fine chemical enzymes* are used to obtain high value chiral building blocks as enzymes present stereo-, regio-, and chemo-selectivity. The biocatalyzed processes are also favored, in comparison to the traditional organic synthesis processes, because they present high catalytic efficiency and are able to perform in mild reaction conditions regarding pH, temperature, and pressure. In addition, the use of enzyme catalyzed reactions avoids the formation of undesirable by-products, due to the biocatalysts specificity. Selected biocatalysts are also able to perform in the presence of organic solvents, making up for the poor aqueous solubility of a number of reaction substrates and products. Pharmaceuticals, the most important products from fine-chemistry, account for over 50 % of all products from this enzyme segment. Hydrolases (lipases, proteases, amidases, and glycosidases) are the main enzymes applied in these industrial processes. Nevertheless, lyases, transferases, isomerases, and oxidoreductases have also been used. Whole cells have been also extensively used in industrial biotransformations. Their application is noteworthy in redox reactions due to their ability to regenerate cofactors (Liese et al. 2006; Fessner and Anthonsen 2009). The introduction of smaller and newer molecular drugs in the market involves a complicated and intricate process, which is likely to compel pharmaceutical companies to shift toward biotechnology and to the wider application of enzymes in fine chemicals.

Perspectives

All in all, the industrial use of biocatalysts increased twofold in the last ten years in response to the consolidated demand for sustainable development which is based on the use of renewable raw materials via the so-called carbon and environmental neutral technologies (Sá-Pereira 2008). Genomes sequencing and advances in genetic engineering, working hand in hand with the call for industrial biocatalyzed processes, diversification, and robustness, has prompted a significant increase in the diversity of commercially available enzymes with lower costs. Furthermore, enzyme rational redesign and directed evolution, as well as high-throughput screening of both enzymes and bacterial cells among, for example, extremophiles, have led to novel biocatalysts with industrial applications. A better understanding of cell metabolism as well as the identification of metabolic targets forecasts a market increase for therapeutic and diagnosis enzymes. Chirality, a most desirable feature for advanced therapeutic drugs, is also moving forward due to the growing use of biocatalysts in organic synthesis.

Acknowledgments

We would like to thank the technical assistance of Ms. Denise da Rocha de Souza, supported by fellowships from MCT/CNPq. Research supported by CAPES, FAPERJ, MCT/CNPq, and Conselho de Ensino para Graduados e Pesquisas (CEPG/UFRJ).

References

- Adekoya OA, Sylte I (2009) The thermolysin family (M4) of enzymes: therapeutic and biotechnological potential. *Chem Biol Drug Design* 73:7–16
- Ager DJ, Pantaleone DP, Henderson SA, Katritzky AR, Prakash I, Walters DE (1998) Commercial, synthetic nonnutritive sweeteners. *Angew Chemie Int Ed* 37:1802–1817
- Ando H, Adachi M, Umeda K, Matsuura A, Nonaka M, Uchio R, Tanaka H, Motoki M (1989) Purification and characteristics of a novel transglutaminase derived from microorganisms. *Agric Biol Chem* 53:2613–2617
- Andreas J, Filho EXF (2008) Biotechnology of holocellulose-degrading enzymes. In: Hou CT, Shaw J-F (eds) *Biocatalysis and bioenergy*. Wiley, New York, pp 197–229
- Arantes V, Saddler JN (2010) Access to cellulose limits the efficiency of enzymatic hydrolysis: the role of amorphogenesis. *Biotechnol Biofuels* 3:4–12
- Aravindan R, Anbumathi P, Viruthagiri T (2007) Lipase applications in food industry. *Indian J Biotechnol* 6:141–158
- Arpigny JL, Jaeger KE (1999) Bacterial lipolytic enzymes: classification and properties. *Biochem J* 343:177–183
- Arrizubieta MJ (2007) Transglutaminases. In: Polaina J, MacCabe AP (eds) *Industrial enzymes: structure, function and applications*. Springer, New York, pp 567–581
- Atkinson HJ, Babbitt PC, Sajid M (2009) The global cysteine peptidase landscape in parasites. *Trends Parasitol* 25(12):573–581
- Banbula A (1998) Amino-acid sequence and three-dimensional structure of the *Staphylococcus aureus* metalloproteinase at 1.72 Å resolution. *Structure* 6:1185–1193
- Banerjee G, Scott-Craig JS, Walton JD (2010) Improving enzymes for biomass conversion: a basic research perspective. *Bioenerg Res* 3:82–92
- Battistuzzi G, Bellei M, Bortolotti CA, Sola M (2010) Redox properties of heme peroxidases. *Arch Biochem Biophys* 500:21–36
- Bayer EA, Belaich J-P, Shoham Y, Lamed R (2004) The cellulosomes: multienzyme machines for degradation of plant cell wall polysaccharides. *Annu Rev Microbiol* 58:521–524
- Bayer EA, Lamed R, White BA, Flint HJ (2008) From cellulosomes to cellulosomes. *Chem Rec* 8:364–377
- Benner SA, Sismour AM (2005) Synthetic biology. *Nat Rev Genet* 6:6533–6544
- Betzel C, Klupsch S, Papendorf G, Hastrup S, Branner S, Wilson KS (1992) Crystal structure of the alkaline proteinase Savinase™ from *Bacillus lentus* at 1.4 Å resolution. *J Mol Biol* 223:427–445
- Bloois EV, Pazmiño DET, Winter RT, Fraaije MW (2010) A robust and extracellular heme-containing peroxidase from *Thermobifida fusca* as prototype of a bacterial peroxidase superfamily. *Appl Microbiol Biotechnol* 86:1419–1430
- Blumer-Schuetz SE, Kataeva I, Westpheling J, Adams MWW, Kelly RM (2008) Extremely thermophilic microorganisms for biomass conversion: status and prospects. *Curr Opin Biotechnol* 19:210–217
- Bode HB, Bethe B, Höfs R, Zeeck A (2002) Big effects from small changes: possible way to explore nature's chemical diversity. *Chembiochem* 3:619–627
- Bommarius AS, Blum JK, Abrahamson MJ (2011) Status of protein engineering for biocatalysts: how to design an industrially useful biocatalyst. *Curr Opin Chem Biol* 15:194–200
- Böttcher D, Bornscheuer UT (2010) Protein engineering of microbial enzymes. *Curr Opin Microbiol* 13:274–292
- Brady D, Jordaan EJ (2009) Advances in enzyme immobilisation. *Biotechnol Lett* 31:1639–1650
- Brown ME, Walker MC, Nakashige TG, Iavarone AT, Chang MC (2011) Discovery and characterization of heme enzymes from unsequenced bacteria: application to microbial lignin degradation. *J Am Chem Soc* 133(45):18006–18009. doi:10.1021/ja203972q
- Brustad EM, Arnold FH (2011) Optimizing non-natural protein function with directed evolution. *Curr Opin Chem Biol* 15:201–210
- Busto E, Gotor-Fernandez V, Gotor V (2010) Hydrolases: catalytically promiscuous enzymes for non-conventional reactions in organic synthesis. *Chem Soc Rev* 39:4504–4523

- Cai J, Xie Y, Song B, Wang Y, Zhang Z, Feng Y (2011) *Fervidobacterium changbaicum* Lip1: identification, cloning, and characterization of the thermophilic lipase as a new member of bacterial lipase family V. *Appl Microbiol Biotechnol* 89:1463–1473
- Caloni F (2009) Safety and efficacy of Ronozyme® ProAct (serine protease) for use as feed additive for chickens for fattening (EFSA panel on additives and products or substances used in animal feed, EFSA panel on genetically modified organisms). *EFSA J* 1185:1–15, ISSN 1831-4732.-7:7
- Cardenas F, de Castro MS, Sanchez-Montero JM, Sinisterra JV, Valmaseda M, Elson SW, Alvarez E (2001) Novel microbial lipases: catalytic activity in reactions in organic media. *Enzyme Microb Technol* 28:145–154
- Carere CR, Sparling R, Cicek N, Levin DB (2008) Third generation biofuels via direct cellulose fermentation. *Int J Mol Sci* 9:1342–1360
- Carvalho CCCR (2011) Enzymatic and whole cell catalysis: finding new strategies for old processes. *Biotechnol Adv* 29:75–83
- Casadio GM, Bergamini RCM (2002) Transglutaminases: nature's biological glues. *Biochem J* 368:377–396
- Chao YP, Xie FH, Yang J, Lu JH, Qian SJ (2007) Screening for a new *Streptomyces* strain capable of efficient keratin degradation. *J Environ Sci* 19:1125–1128
- Charpe TW, Rathod VK (2010) Biodiesel production using waste frying oil. *Waste Manag* 26:487–494
- Chartrain M, Katz L, Marcin C, Thien M, Smith S, Fisher E (1993) Purification and characterization of a novel bioconverting lipase from *Pseudomonas aeruginosa* MB 5001. *Enzyme Microb Technol* 15:575–580
- Chater KF, Biró S, Lee KJ, Palmer T, Schrempf H (2010) *FEMS Microbiol Rev* 34:171–198
- Chen Z, Wilmanns M, Zeng AP (2010) Structural synthetic biotechnology: from molecular structure to predictable design for industrial strain development. *Trends Biotechnol* 28(10):535–542
- Chen R, Guo L, Dang H (2011) Gene cloning, expression and characterization of a cold-adapted lipase from a psychrophilic deep-sea bacterium *Psychrobacter* sp. C18. *World J Microbiol Biotechnol* 27:431–441
- Chi MC, Chen YH, Wu TJ, Lo HF, Lin LL (2010) Engineering of a truncated α -amylase of *Bacillus* sp. strain TS-23 for the simultaneous improvement of thermal and oxidative stabilities. *J Biosci Bioeng* 109(6):531–538
- Copley SD, Novak WR, Babbitt PC (2004) Divergence of function in the thioredoxin fold suprafamily: evidence for evolution of peroxiredoxins from a thioredoxin-like ancestor. *Biochemistry* 43(44):13981–13995
- Cortez J, Bonner PLR, Griffin M (2004) Application of transglutaminases in the modification of wool textiles. *Enzyme Microb Technol* 34:64–72
- Cortez J, Anghierib A, Bonnera PLR, Griffin M, Freddi G (2007) Transglutaminase mediated grafting of silk proteins onto wool fabrics leading to improved physical and mechanical properties. *Enzyme Microb Technol* 40:1698–1704
- Darwin KH (2009) Prokaryotic ubiquitin-like protein (Pup), proteasomes and pathogenesis. *Nat Rev Microbiol* 7(7):485–491
- Dash C, Kulkarni A, BenRao M (2003) Aspartic peptidase inhibitors: implications in drug development. *Crit Rev Biochem Mol Biol* 38:89–119
- Date M, Yokoyama K, Umezawa Y, Matsui H, Kikuchi Y (2003) Production of native-type *Streptovorticillium mobaraense* transglutaminase in *Corynebacterium glutamicum*. *Appl Environ Microbiol* 69:3011–3014
- Davies GJ, Henrissat B (1995) Structures and mechanisms of glycosyl hydrolases. *Structure* 3:853–859
- Demain AL, Newcomb M, Wu JHD (2005) Cellulase, clostridia, and ethanol. *Microbiol Mol Biol Rev* 69:124–154
- Dharmsthiti S, Pratuangdejkul J, Theeragool GT, Luchai S (1998) Lipase activity and gene cloning of *Acinetobacter calcoaceticus* LP009. *J Gen Appl Microbiol* 44:139–145
- Dheeman DS, Henehan GTM, Frias JM (2011) Purification and properties of *Amycolatopsis mediterranei* DSM 43304 lipase and its potential in flavour ester synthesis. *Bioresour Technol* 102:3373–3379
- Dive V, Yiotakis A, Nicolaou A, Toma F (1990) Inhibition of *Clostridium histolyticum* collagenases by phosphonamide peptide inhibitors. *Eur J Biochem* 191:685–693
- Dolynchuk KN, Bowness JM (1999) Use of transglutaminase inhibitor for the treatment of scar tissue. US Patent US5885982
- Doman-Pytka M, Bardowski J (2004) Pullulan degrading enzymes of bacterial origin. *Crit Rev Microbiol* 30(2):107–121
- Du X, Choi GC, Kim R, Wang W, Jancarik J, Yokota H, Kim SH (2000) Crystal structure of an intracellular protease from *Pyrococcus horikoshii* at 2-Å resolution. *Proc Natl Acad Sci* 97(26):14079–14084
- Eckert LR, Sturniolo MT, Broome AM, Ruse M, Rorke EA (2005) Transglutaminase function in epidermis. *J Invest Dermatol* 124:481–492
- Fan Z, Yue C, Tang Y, Zhang V (2009) Cloning, sequence analysis and expression of bacterial lipase-coding DNA fragments from environment in *Escherichia coli*. *Mol Biol Rep* 36:1515–1519
- Feller G, Gerday G (2003) Psychrophilic enzymes: hot topics in cold adaptation. *Nat Rev Microbiol* 1(3):200–208
- Ferrer M, Beloqui A, Golyshina OV, Plou FJ, Neef A, Chernikova TN, Fernández-Arrojo L, Ghazi I, Ballesteros A, Elborough K, Timmis KN, Golyshin PN (2007) Biochemical and structural features of a novel cyclodextrinase from cow rumen metagenome. *Biotechnol J* 2(2):207–213
- Fessner W, Anthonsen A (2009) Modern biocatalysis. Wiley-VCH, Weinheim
- FitzGerald RJ, O'Cuinn G (2006) Enzymatic debittering of food protein hydrolysates. *Biotechnol Adv* 24:234–237
- Folk JE (1980) Transglutaminases. *Annu Rev Biochem* 49:517–531
- Freedonia (2005) World enzymes to 2009. Freedonia Group Incorporated, Cleveland
- Freedonia (2009) World enzymes to 2013 – Market research, market share, market size, sales, demand forecast, market leaders, company profiles, industry trends. Freedonia Group Incorporated, Cleveland, <http://www.freedoniagroup.com/World-Enzymes.html>. Accessed 05 Jul 2011
- Friedrich J, Gradisar H, Vrecl M, Pogacnik A (2005) In vitro degradation of porcine skin epidermis by a fungal keratinase of *Doratomyces microsporus*. *Enzyme Microb Technol* 36:455–460
- Fukuda H, Hama S, Talamampudi S, Noda H (2008) Whole-cell biocatalysts for biodiesel fuel production. *Trends Biotechnol* 26:668–673
- Fusek M, Lin XL, Tang T (1990) Enzymic properties of thermopsin. *J Biol Chem* 265:1496–1501
- Gao DN, Uppugundia SPS, Chundawat X, Yu S, Hermanson K, Gowda P, Brumm D, Mead VB, Dale BE (2010) Hemicellulases and auxiliary enzymes for improved conversion of lignocellulosic biomass to monosaccharides. *Biotechnol Biofuels* 4:5
- Garabito MJ, Maquez MC, Ventosa A (1998) Halotolerant *Bacillus* diversity in hypersaline environments. *Can J Microbiol* 44:95–102
- Garcia-Arellano H, Alcalde M, Ballesteros A (2004) Use and improvement of microbial redox enzymes for environmental purposes. *Microb Cell Fact* 3:10
- Gerritse G, Hommes RW, Quax WJ (1998) Development of a lipase fermentation process that uses a recombinant *Pseudomonas alcaligenes* strain. *Appl Environ Microbiol* 64(7):2644–2651
- Gibson DG, Benders GA, Andrews-Pfannkoch C, Denisova EA, Baden-Tillson H, Zaveri J, Stockwell TB, Brownley A, Thomas DW, Algire MA, Merryman C, Young L, Noskov VN, Glass JL, Enter JV, Hutchison CA III, Smith HO (2008) Complete chemical synthesis, assembly, and cloning of a *Mycoplasma genitalium* genome. *Science* 319:1215–1220
- Griffin M, Casadio R, Bergamini CM (2002) Transglutaminases: nature's biological glues. *Biochem J* 368:377–396
- Gilbert HJ (2007) Cellulosomes: microbial nanomachines that display plasticity in quaternary structure. *Mol Microbiol* 63(6):1568–1576
- Gilbert HJ, Hazlewood GP (1993) Bacterial cellulases and xylanases. *J Gen Microbiol* 139:187–194
- Ginalski K, Kinch L, Leszek Rychlewski L, Grishin NV (2004) BTLCP proteins: a novel family of bacterial transglutaminase-like cysteine proteinases. *Trends Biochem Sci* 29(8):392–395
- Global Industry Analysts (2011) Industrial enzymes: a global strategic business report. Global Industry Analysts, San Jose, http://www.prweb.com/releases/industrial_enzymes/proteases_carbohydrases/prweb8121185.htm. Accessed 05 July 2011
- Goldberg DM (2005) Clinical enzymology: an autobiographical history. *Clin Chim Acta* 357:93–112
- Gosh PK, Saxena RK, Gupta R, Yadav RP, Davison S (1996) Microbial lipases: production and applications. *Sci Prog* 79:119–157

- Gottesman S (2003) Proteolysis in bacterial regulatory circuits. *Annu Rev Cell Dev Biol* 19:565–587
- Govan V, Deretic V (1996) Microbial pathogenesis in cystic fibrosis: mucoid *Pseudomonas aeruginosa* and *Burkholderia cepacia*. *Microbiol Rev* 60:539–574
- Gradisar H, Friedrich J, Krizaj I, Jerala R (2005) Similarities and specificities of fungal keratinolytic proteases: comparison of keratinases of *Paecilomyces marquandii* and *Doratomyces microsporus* to some known proteases. *Appl Environ Microbiol* 71:3420–3426
- Green H, Dijan P (1996) Cosmetic containing comeocyte proteins and transglutaminase, and method of application. US Patent US5525336
- Grenier D, Tanabe S (2010) *Porphyromonas gingivalis* gingipains trigger a proinflammatory response in human monocyte-derived macrophages through the p38 α mitogen-activated protein kinase signal transduction pathway. *Toxins* 2:341–352
- Grunenfelder B, Rummel G, Vohradsky J, Roder D, Langen H, Jenal U (2001) Proteomic analysis of the bacterial cell cycle. *Proc Natl Acad Sci* 98:4681–4686
- Gupta R, Gupta N, Rathi P (2004) Bacterial lipases: an overview of production, purification and biochemical properties. *Appl Biochem Biotechnol* 64:763–781
- Gupta R, Ramnani P (2006) Microbial keratinases and their prospective applications: an overview. *Appl Microbiol Biotechnol* 70:21–33
- Gupta P, B LS, Shrivastava R (2011) Lipase catalyzed- transesterification of vegetable oils by lipolytic bacteria. *Research J Microbiol* 6:281–288
- Hadeball W (1991) Production of lipase by *Yarrowia lipolytica* I. Lipases from yeasts. *Acta Biotechnol* 11:159–167
- Hahn-Hagerdal B, Galbe M, Gorwa-Grauslund MF, Lidén G, Zacchi G (2006) Bio-ethanol—the fuel of tomorrow from the residues of today. *Trends Biotechnol* 24(12):549–556
- Hamid NSA, Zen HB, Tein OB, Halifah YM, Saari N, Bakar FA (2003) Screening and identification of extracellular lipase-producing thermophilic bacteria from a Malaysian hot spring. *World J Microbiol Biotechnol* 19:961–968
- Hasan F, Shah AA, Hameed A (2006) Industrial applications of microbial lipases. *Enzyme Microb Technol* 39:235–251
- Hasan F, Shah AA, Hameed A (2009) Methods for detection and characterization of lipases: a comprehensive review. *Biotechnol Adv* 27:782–798
- Hasan F, Shah AA, Javed S, Hameed A (2010) Enzymes used in detergents: lipases. *Afr J Biotechnol* 9:4836–4844
- Hess M, Sczyrba A, Egan R, Kim T-W, Chokhwalwa H, Schroth G, Luo S, Clark DS, Chen F, Zhang T, Mackie RI, Pennacchio LA, Tringe SG, Visel A, Woyke T, Wang Z, Rubin EM (2011) Metagenomic discovery of biomass-degrading genes and genomes from cow rumen. *Science* 331(28):463–467
- Hettinga WG, Junginger HM, Dekker SC, Hoogwijk M, Mcaloon AJ, Hicks KB (2009) Understanding the reductions in US corn ethanol production costs: an experience curve approach. *Energy Policy* 37:190–203
- Himmel ME, Ruth MF, Wyman CE (1999) Cellulase for commodity products from cellulose biomass. *Curr Opin Biotechnol* 10:358–364
- Himmel ME, Ding S-Y, Johnson DK, Adney WS, Nimtos MR, Brady JW, Foust TD (2007) Biomass recalcitrance: engineering plants and enzymes for biofuels production. *Science* 315:804–807
- Hofmann B, Hecht HJ, Flohé L (2002) Peroxiredoxins. *J Biol Chem* 277(3):347–364
- Horiguchi Y, Inoue N, Masuda M, Kashimoto T, Katahira J, Sugimoto N, Matsuda M (1997) *Bordetella bronchiseptica* dermonecrotizing toxin induces reorganization of actin stress fibers through deamidation of Gln-63 of the GTP binding protein Rho. *Proc Natl Acad Sci USA* 94:11623–11626
- Horimoto Y, Dee DR, Yada RY (2009) Multifunctional aspartic peptidase prosegments. *N Biotechnol* 25:318–324
- Horta BB, Oliveira MA, Discola KF, Cussiol JRR, Netto LES (2010) Structural and biochemical characterization of peroxiredoxin Q β from *Xylella fastidiosa*. *J Biol Chem* 285(21):16051–16065
- Hough DW, Danson MJ (1999) Extremozymes. *Curr Opin Chem Biol* 3:39–46
- Hu BH, Messersmith PB (2003) Formation of hydrogels. *J Am Chem Soc* 125:14298–14299
- Ilies M, Banciu MDM, Scozzafava A, Ilies MA, Caproiu MT, Supuran CT (2003) Protease inhibitors: synthesis of bacterial collagenase and matrix metalloproteinase inhibitors incorporating arylsulfonyleureido and 5-Dibenzo- suberenyl/suberyl moieties. *Bioorg Med Chem* 11:2227–2239
- Jaeger KE, Reetz MT (1998) Microbial lipases form versatile tools for biotechnology. *Trends Biotechnol* 16:396–403
- Jaeger KE, Dijkstra BW, Reetz MT (1999) Bacterial biocatalysts: molecular biology, three-dimensional structures and biotechnological applications of lipases. *Annu Rev Microbiol* 53:315–351
- Jaeger K-E, Eggert T, Eipper A, Reetz MT (2001) Directed evolution and the creation of enantioselective biocatalysts. *Appl Microbiol Biotechnol* 55: 519–530
- Jensen K, Østergaard PR, Wilting R, Lassen SF (2010) Identification and characterization of a bacterial glutamic peptidase. *BMC Biochem* 11:47
- Joong-Jae K, Masui R, Kuramitsu S, Seo JH, Kim K, Sung MH (2008) Characterization of growth-supporting factors produced by *Geobacillus toebii* for the Commensal Thermophile *Symbiobacterium toebii*. *J Microbiol Biotechnol* 18(3):490–496
- Joseph B, Ramteke PW, Thomas G (2008) Cold active microbial lipases: some hot issues and recent developments. *Biotechnol Adv* 26:457–470
- Josten A, Meusel M, Spener F, Haalck L (1999) Enzyme immobilization via microbial transglutaminase: a method for the generation of stable sensing surfaces. *J Mol Catal B Enzym* 7:57–66
- Kamijo T, Saito A, Ema S, Yoh I, Hayashi H, Nagata R, Nagata Y, Ando A (2011) Molecular and enzymatic characterization of a subfamily I.4 lipase from an edible oil-degrader *Bacillus* sp. HH-01. *Antonie van Leeuwenhoek* 99: 179–187
- Kanjanavas P, Khuchareontaworn S, Khawsak P, Pakpitcharoen A, Pothivejkul K, Santiwatanakul S, Matsui K, Kajiwara T, Chansiri K (2010) Purification and characterization of organic solvent and detergent tolerant lipase from thermotolerant *Bacillus* sp. RN2. *Int J Mol Sci* 11:3783–3792
- Kanlayakrit W, Boonpan A (2007) Screening of halophilic lipase-producing bacteria and characterization of enzyme for fish sauce quality improvement. *Kasetsart J Nat Sci* 41:576–585
- Kantyka T, Rawlings ND, Potempa J (2010) Prokaryote-derived protein inhibitors of peptidases: a sketchy occurrence and mostly unknown function. *Biochimie* 92:1644–1656
- Kashiwagi T, Yokoyama K, Ishikawa K, Ono K, Ejima D, Matsui H, Suzuki E (2002) Crystal structure of microbial transglutaminase from *Streptovorticillum mobaraense*. *J Biol Chem* 277:44252–44260
- Keasling JD (2010) Manufacturing molecules through metabolic engineering. *Science* 330:301–355
- Kelly RM, Dijkhuizen L, Leemhuis H (2009) Starch and α -glucan acting enzymes, modulating their properties by direct evolution. *J Biotechnol* 140:184–193
- King BC, Waxman KD, Nenni NV, Walker LP, Bergstrom GC, Gibson DM (2011) Arsenal of plant cell wall degrading enzymes reflects host preference among plant pathogenic fungi. *Biotechnol Biofuels* 4:4
- Kobayashi K, Yamanaka S, Miwa K, Suzuki S, Eto Y, Tanita Y, Yokozeki K, Hashiguchi K (1999) *Bacillus*-derived TGase US 5731183
- Kobayashi K, Yamanaka S, Tanita Y, Tsuyoshi N, Fudo R, Shinozaki J, Yokozeki K, Suzuki S (2002) Process for producing transglutaminase by microorganism US 6472182
- Kornilowicz-Kowalska T, Justyna B (2011) Biodegradation of keratin waste: theory and practical aspects. *Waste Manag* 31(8):1689–1701
- Kumar R, Singh S, Singh OV (2008) Bioconversion of lignocellulosic biomass: biochemical and molecular perspectives. *J Ind Microbiol Biotechnol* 35: 377–391
- Kunert J (1972) Keratin decomposition by dermatophytes: evidence of the sulphitolysis of the protein. *Experientia* 28:1025–1026
- Kuraishi C, Yamazaki K, Susa Y (2001) Transglutaminase: its utilization in the food industry. *Food Rev Int* 17:221–232
- Kwak J, Lee K, Shin DH, Maeng JS, Park DS, Oh HW, Son KH, Bae KS (2007) Biochemical and genetic characterization of arazyme, an extracellular metalloprotease produced from *Serratia proteamaculans* HY-3. *J Microbiol Biotechnol* 175(5):761–768
- Lagaert S, Beliën T, Volckaert G (2009) Plant cell walls: protecting the barrier from degradation by microbial enzymes. *Semin Cell Dev Biol* 20:1064–1073
- Larre C, Denery Papini S, Popineau Y, Deshayes C, Desserre C, Lefebvre J (2000) Biochemical analysis and rheological properties of gluten modified by transglutaminase. *Cereal Chem* 77:121–127

- Lazniewski M, Steczkiewicz K, Knizewski L, Wawer I, Ginalski K (2011) Novel transmembrane lipases of alpha/beta hydrolase fold. *FEBS Lett* 585:870–874
- Leschine SB (1995) Cellulose degradation in anaerobic environments. *Annu Rev Microbiol* 49:399–426
- Li X-H, Yang H-J, Roy B, Wang D, Yue W-F, Jiang L-J, Park EY, Miao Y-G (2009) The most stirring technology in future: cellulase enzyme and biomass utilization. *Afr J Biotechnol* 8:2418–2422
- Liese A, Seelbach K, Wandrey C (2006) Industrial biotransformations. Wiley-VCH, Weinheim
- Lin X, Tang J (1990) Purification, characterization, and gene cloning of thermopsin, a thermostable acid protease from *Sulfolobus acidocaldarius*. *J Biol Chem* 265:1490–1495
- Lin X, Wong SL, Miller ES, Shih JCH (1997) Expression of the *Bacillus licheniformis* PWD-1 keratinase gene in *B. subtilis*. *J Ind Microbiol Biotechnol* 19:134–138
- López-Otín C, Matrisian LM (2007) Emerging roles of proteases in tumour suppression. *Nat Rev Cancer* 7:800–808
- Luetz S, Giver L, Lalonde J (2008) Engineered enzymes for chemical production. *Biotechnol Bioeng* 101:647–653
- Lynd LR, Van WH, Zyl JEMB, Laser M (2005) Consolidated bioprocessing of cellulosic biomass: an update. *Curr Opin Biotechnol* 16:577–583
- Ma J, Zhang Z, Wang B, Kong X, Wang Y, Shugui Cao S, Feng Y (2006) Overexpression and characterization of a lipase from *Bacillus subtilis*. *Protein Expr Purif* 45:22–29
- Makarova KS, Aravind L, Koonin EV (1999) A superfamily of archaeal, bacterial, and eukaryotic proteins homologous to animal transglutaminases. *Protein Sci* 8(8):1714–1719
- Maki M, Leung KT, Qin W (2009) The prospects of cellulase-producing bacteria for the bioconversion of lignocellulosic biomass. *Int J Biol Sci* 5:500–516
- Mala JGS, Takeuchi S (2008) Understanding structural features of microbial lipases: an overview. *Anal Chem* 3:9–19
- Malloy JL, Thibodeaux RAW, O'Callaghan BARJ, Wright JR (2005) *Pseudomonas aeruginosa* protease IV degrades surfactant proteins and inhibits surfactant host defense and biophysical functions. *J Physiol Lung Cell Mol Physiol* 288: L409–L418
- Marin-Navarro J, Polaina J (2011) Glucoamylases: structural and biotechnological aspects. *Appl Microbiol Biotechnol* 89:1267–1273
- Maurer KH (2004) Detergent proteases. *Curr Opin Biotechnol* 15:330–334
- McDermott MK, Chen T, Williams CM, Markley KM, Payne GF (2004) Mechanical properties of biomimetic tissue adhesive based on the microbial transglutaminase-catalyzed crosslinking of gelatin. *Biomacromolecules* 5:1270–1279
- Merino ST, Cherry J (2007) Progress and challenges in enzyme development for biomass utilization. *Adv Biochem Eng Biotechnol* 108:95–120
- Messaoudi A, Belguith H, Gram I, Hamida JB (2010) Classification of EC 3.1.1.3 bacterial true lipases using phylogenetic analysis. *African J Biotechnol* 9:8243–8247
- Metzmacher I, Ruth P, Abel M, Friess W (2007) In vitro binding of matrix metalloproteinase-2 (MMP-2), MMP-9, and bacterial collagenase on collagenous wound dressings. *Wound Repair Regen* 2:549–555
- Míreya Santos M, Torné JM (2009) Recent patents on transglutaminase production and applications: a brief review. *Recent Pat Biotechnol* 3:166–174
- Mohorcic MA, Torkar A, Friedrich J, Kristl J, Murdan S (2007) An investigation into keratinolytic enzymes to enhance unguinal drug delivery. *Int J Pharm* 332:196–201
- Monroe A, Setlow P (2006) Localization of the transglutaminase cross-linking sites in the *Bacillus subtilis* spore coat protein GerQ. *J Bacteriol* 188: 7609–7616
- Moreira LRS, von Gal Milanezi N, Filho EXF (2011) Enzymology of plant cell wall breakdown: an update. In: Buckeridge MS, Goldman GH (eds) *Routes to cellulosic ethanol*. Springer, New York, pp 73–96
- Murata S, Yashiroda S, Tanaka K (2009) Molecular mechanisms of proteasome assembly. *Nat Rev* 10:104–115
- Murooka Y, Yamashita M (2001) Genetic and protein engineering of diagnostic enzymes, cholesterol oxidase and xylitol oxidase. *J Biosci Bioeng* 91:433–441
- Muszbek L, Adany R, Mikkola H (1996) Novel aspects of blood coagulation factor XIII. I. Structure, distribution, activation, and function. *Crit Rev Clin Lab Sci* 3:357–421
- Nardini M, Dijkstra BW (1999) α/β Hydrolase fold enzymes: the family keeps growing. *Curr Opin Struct Biol* 9:732–737
- Nataf Y, Bahari L, Kahel-Raifer H, Borovak I, Lamed R, Bayer EA, Sonenshein AL, Shoham Y (2010) *Clostridium thermocellum* cellulosomal genes are regulated by extracytoplasmic polysaccharides via alternative sigma factors. *Proc Natl Acad Sci* 107(43):18646–18651
- Neves MA, Kimura T, Shimizu N, Nakajima M (2007) State of the art and future trends of bioethanol production. *Dyn Biochem Process Biotech Mol Biol* 1:1–14
- Ney KH (1979) Bitterness of peptides: amino acid composition and chain length. In: Bondreau JC (ed) *Food taste chemistry*. American Chemical Society, Washington, DC, pp 149–173
- Nghiem NP, Taylor F, Johnston DB, Shelly JK, Hicks KB (2011) Scale-up of ethanol production from winter barley by the EDGE (enhanced dry grind enzymatic) process in fermentors up to 300 l. *Appl Biochem Biotechnol* 165(3–4):870–882. doi:10.1007/s12010-011-9304-1
- Nichaus F, Bertoldo C, Kühler M, Antranikian G (1999) Extremophiles as a source of novel enzymes for industrial application. *Appl Microbiol Biotechnol* 89:1267–1273
- Ohnishi A, Nagano A, Fujimoto N, Suzuki M (2011) Phylogenetic and physiological characterization of mesophilic and thermophilic bacteria from a sewage sludge composting process in Sapporo, Japan. *World J Microbiol Biotechnol* 27:333–340
- Olempska-Beer ZWS, Merker RI, Ditto MD, DiNovi MJ (2006) Food-processing enzymes from recombinant microorganisms—a review. *Regul Toxicol Pharmacol* 45:144–158
- Orenzen PC, Schlimme E (1998) Properties and potential fields of application of transglutaminase preparations in dairying. *Bull Int Dairy Fed* 332:347
- Otero JM, Nielsen J (2010) Industrial systems biology. *Biotechnol Bioeng* 105:439–460
- Paetzel M, Andrew K, Strynadka NCJ, Dalbey RE (2002) Signal peptidases. *Chem Rev* 102:4549–4579
- Panesar PS, Marwaha SS, Kennedy JF (2006) *Zymomonas mobilis*: an alternative ethanol producer. *J Chem Technol Biotechnol* 81:623–635
- Pariza MW, Cook M (2010) Determining the safety of enzymes used in animal feed. *Regul Toxicol Pharmacol* 56:332–342
- Pason P, Kosugi A, Waonukul R, Tachaapaikoon C, Ratanakhanokchai K, Arai T, Murata Y, Nakajima J, Mori Y (2010) Purification and characterization of a multienzyme complex produced by *Paenibacillus curdolanolyticus* B-6. *J Ind Microbiol Biotechnol* 85:573–580
- Peng R, Lin J, Wei D (2010) Purification and characterization of an organic solvent-tolerant lipase from *Pseudomonas aeruginosa* CS-2. *Appl Biochem Biotechnol* 162:733–743
- Pérez J, Muñoz-Dorado J, de la Rubia T, Martínez J (2002) Biodegradation and biological treatments of cellulose, hemicellulose and lignin: an overview. *Int Microbiol* 5:53–63
- Plácido D, Fernandes CG, Carrondo IA, Henriques MA, Adriano HO, Archer M (2008) Auto-induction and purification of a *Bacillus subtilis* transglutaminase (Tgl) and its preliminary crystallographic characterization. *Protein Expr Purif* 59:1–8
- Pohlenz HD, Boidol W, Schuttke I, Streber W (1992) Purification and properties of an *Arthrobacter oxydans* P52 carbamate hydrolase specific for the herbicide phenmedipham and nucleotide sequence of the corresponding gene. *J Bacteriol* 174:6600–6607
- Polgar L (2005) The catalytic triad of serine peptidases. *Cell Mol Life Sci* 62:2161–2172
- Poole LB (2005) Bacterial defenses against oxidants: mechanistic features of cysteine-based peroxidases and their flavoprotein reductases. *Arch Biochem Biophys* 433:240–254
- Popa VI (1998) Enzymatic hydrolysis of hemicelluloses and cellulose. In: Severian D (ed) *Polysaccharides structural diversity and functional versatility*. Marcel Dekker, New York, pp 969–1006
- Potempa JJ, Pike RN (2009) Corruption of innate immunity by bacterial proteases. *J Innate Immun* 1:70–87

- Potvin E, Lehoux DE, Kukavica-Ibrulj I, Richard KL, Sanschagrin F, Law GW, Levesque RC (2003) *Pseudomonas* in vivo functional genomic for high-throughput screening of new virulence factors and antibacterial targets. *Environ Microbiol* 5(12):1294–1308
- Prakash O, Jaiswal N (2010) α -Amylase: an ideal representative of thermostable enzymes. *Appl Biochem Biotechnol* 160:2401–2414
- Qing X, Zhang XH (2002) Detergent enzyme application handbook version 2. Chinese Light Industry Press and Novozymes, Beijing
- Ragkousi K, Setlow P (2004) Transglutaminase-mediated cross-linking of GerQ in the coats of *Bacillus subtilis* spores. *J Bacteriol* 186(17):5567–5575
- Rahman RNZRA, Baharum SN, Basri M (2005) High-yield purification of an organic solvent-tolerant lipase from *Pseudomonas* sp. strain S5. *Anal Biochem* 341:267–274
- Raksakulthai R, Haard NF (2003) Exopeptidases and their application to reduce bitterness in food: a review. *Crit Rev Food Sci Nutr* 43(4):401–445
- Raman B, Pan C, Hurst GB, Rodriguez M, McKeown CK, Lankford PK, Samatova NF, Mielenz JR (2009) Impact of pretreated switchgrass and biomass carbohydrates on *Clostridium thermocellum* ATCC 27405 cellulose composition: a quantitative proteomic analysis. *PLoS ONE* 4(4):e5271
- Ramrani P, Singh R, Gupta R (2005) Keratinolytic potential of *Bacillus licheniformis* RG1: structural and biochemical mechanism of feather degradation. *Can J Microbiol* 51:191–196
- Rathi P, Saxena RK, Gupta R (2001) A novel alkaline lipase from *Burkholderia cepacia* for detergent formulation. *Process Biochem* 37:187–192
- Rawlings ND, Barrett AJ (2004) Introduction: metallopeptidases and their clans. In: Barrett AJ, Rawlings ND, Woessner JF (eds) *Handbook of proteolytic enzymes*, 2nd edn. Elsevier, London, pp 231–268
- Rawlings ND, Bateman A (2009) Pepsin homologues in bacteria. *BMC genomics* 10:437–446
- Rawlings ND, Barrett AJ, Bateman A (2010) *MEROPS*: the peptidase database. *Nucl Acids Res* 38:D227–D233
- Reetz MT, Jaeger KE (1998) Overexpression, immobilization and biotechnological application of pseudomonas lipases. *Chem Phys Lipids* 93:3–14
- Renewable Fuels Association (2011) Ethanol industry outlook: building bridges to a more sustainable future. <http://www.ethanolrfa.org/pages/annual-industry-outlook>. Accessed 20 July 2011
- Rodrigues GC, Aguiar AP, Vianez Júnior JLSG, Macrae A, Nogueira de Melo AC, Vermelho AB (2010) Peptidase inhibitors as a possible therapeutic strategy for chagas disease. *Curr Enzyme Inhib* 6:183–194
- Ronkainen NJ, Halsall HB, Heineman WR (2010) Electrochemical biosensors. *Chem Soc Rev* 39(5):1747–1763
- Rosenau F, Jaeger KE (2000) Bacterial lipases from pseudomonas: regulation of gene expression and mechanisms of secretion. *Biochimie* 82:1023–1032
- Rubin EM (2008) Genomics of cellulosic biofuels. *Nature* 454:841–845
- Ruiz C, Blanco A, Javier Pastor FI, Diaz P (2002) Analysis of *Bacillus megaterium* lipolytic system and cloning of LipA, a novel subfamily I.4 bacterial lipase. *FEMS Microbiol Lett* 217(2):263–267
- Ruiz-Herrera J, Iranzo M, Elorza MV, Sentandreu R, Mormeneo S (1995) Involvement of transglutaminase in the formation of covalent cross-links in the cell wall of *Candida albicans*. *Arch Microbiol* 164(3):186–193
- Rye CS, Withers SG (2000) Glycosidase mechanisms. *Curr Opin Chem Biol* 4:573–580
- Sá-Pereira P, Duarte JC, Ferrara MA, Lacerda PSB, Alves FC (2008) Biotatálise: Estratégias de Inovação e Criação de Mercados. In: Bon EPS, Corvo L, Vermelho AB, Paiva CLA, Ferrara MA, Coelho RR, Alencastro RB (eds) *Enzimas em Biotecnologia: Produção, Aplicações e Mercado*. Interciência, Brasil, pp 433–462
- Saeki K, Ozaki K, Kobayashi T, Ito S (2007) Detergent alkaline proteases: enzymatic properties, genes, and crystal structures. *J Biosci Bioeng* 103(6):501–508
- Saha BC, Hayashi K (2001) Debittering of protein hydrolyzates. *Biotechnol Adv* 19:355–370
- Sangeetha R, Arulpandi I, Geetha A (2011) Bacterial lipases as potential biocatalysts: an overview. *Res J Microbiol* 6:1–24
- Sank A, Chi M, Shima T, Reich R, Martin GR (1989) Increased calcium levels alteccellular and molecular events in wound healing. *Surgery* 106:1141–1148
- Sano K, Kumazawa Y, Yasueda H, Seguro K, Motoki M (1998) TGase originating from *Crassostrea gigas* US 5736356
- Santos MAL, Marques S, Gil M, Tegoni M, Scozzafava A, Supuran CT (2003) Protease inhibitors: synthesis of bacterial collagenase and matrix metalloproteinase inhibitors incorporating succinyl hydroxamate and iminodiacetic acid hydroxamate moieties. *J Enzyme Inhib Med Chem* 18:233–242
- Saxena RK, Sheoran A, Giri B, Davidson WS (2003) Purification strategies for microbial lipases. *J Microbiol Methods* 52:1–18
- Schmidt G, Selzer J, Lerm M, Aktories K (1998) The Rho-deamidating cytotoxic necrotizing factor 1 from *Escherichia coli* possesses transglutaminase activity. *J Biol Chem* 273:13669–13674
- Schmidt-dannert C (1999) Recombinant microbial lipases for biotechnological applications. *Bioorg Med Chem* 7:1–8
- Schrempf H (2007) Biology of streptomycetes. In: Dworkin M, Falkow S, Rosenberg E, Schleifer K-H, Stackebrandt E (eds) *The prokaryotes, a handbook on the biology of bacteria*. Springer, New York
- Schwarz WH, Zverlov W, Bahl H (2004) Extracellular glycosyl hydrolases from clostridia. *Adv Appl Microbiol* 56:215–261
- Seitz A, Schneider F, Pasternack R, Fuchsbauer HL, Hampp N (2001) Enzymatic cross-linking of purple membranes catalyzed by bacterial transglutaminase. *Biomacromolecules* 2:233–238
- Serafini-Fracassini D, Del Duca S (2008) Transglutaminases: widespread cross-linking enzymes in plants. *Ann Bot* 102(2):145–152
- Sharma R, Chisti Y, Banerjee UC (2001) Production, purification, characterization, and applications of lipases. *Biotechnol Adv* 19:627–662
- Shu ZY, Jianga H, Lin R-F, Jianga YM, Lina L, Huang JZ (2010) Technical methods to improve yield, activity and stability in the development of microbial lipases. *J Mol Catal B Enzym* 62:1–8
- Sieprawska-Lupa M, Mydel P, Krawczyk K, Wójcik K, Puklo M, Lupa B, Suder P, Silberring J, Reed M, Pohl J, Shafer W, McAleese F, Foster T, Travis J, Potempa J (2004) Degradation of human antimicrobial peptide LL-37 by *Staphylococcus aureus* – derived proteinases. *Antimicrob Agents Chemother* 48:4673–4679
- Siezen RJ, Leunissen JAM (1997) Subtilases: the superfamily of subtilisin-like serine proteases. *Protein Sci* 6:501–523
- Sims R, Taylor M, Saddler J, Mabee W (2008) From 1st to 2nd generation biofuel technologies. Organisation for Economic Co-operation and Development International Energy Agency, France. http://www.iea.org/papers/2008/2nd_Biofuel_Gen_Exec_Sum.pdf. Accessed 11 July 2011
- Singh RN, Mehta K (1994) Purification and characterization of a novel transglutaminase from filarial nematode *Brugia malayi*. *Eur J Biochem* 225:625–634
- Siqueira FG, Filho EFF (2010) Plant cell wall as a substrate for the production of enzymes with industrial applications. *Mini-Rev Org Chem* 7:54–60
- Suh HJ, Lee HK (2001) Characterization of a keratinolytic serine protease from *Bacillus subtilis* KS-1. *J Protein Chem* 20:165–169
- Sukuruman RK, Singhania RR, Pandey A (2005) Microbial cellulases: production, applications and challenges. *J Sci Ind Res* 64:832–844
- Sun H, Zhao P, Ge X, Xia Y, Hao Z, Liu J, Peng M (2010) Recent advances in microbial raw starch degrading enzymes. *Appl Biochem Biotechnol* 160(4):988–1003
- Suzuki Y, Tsujimoto Y, Matsui H, Watanabe K (2006) Decomposition of extremely hard-to-degrade animal proteins by thermophilic bacteria. *J Biosci Bioeng* 102(2):73–81
- Svendsen A (2000) Lipase protein engineering. *Biochim Biophys Acta* 1543(2): 223–228
- Syngkon A, Elluri S, Koley H, Rompikuntal PK, Saha DR, Chakrabarti MK, Bhadra RK, Wai SN, Pal A (2010) Studies on a novel serine protease of a Δ hapA Δ prtV *Vibrio cholerae* O1 strain and its role in hemorrhagic response in the rabbit ileal loop model. *PLoS One* 5:1–11
- Takeuchi H, Shibano Y, Morihara K, Fukushima J, Inami S, Keil B, Gilles AM, Kawamoto S, Okuda K (1992) Structural gene and complete amino acid sequence of *Vibrio alginolyticus* collagenase. *Biochem J* 281:703–708
- Tang J, Lin X (2004) Thermopsin. In: Barrett AJ, Rawlings ND, Woessner JF (eds) *Handbook of proteolytic enzymes*, 2nd edn. Elsevier, London, pp 225–227
- Tang WJ, Zhao H (2009) Industrial biotechnology: tools and applications. *J Biotechnol* 4:1725–1739
- Tasse L, Bercovici J, Pizzut-Serin S, Robe P, Tap J, Klopp C, Cantarel BL, Coutinho PM, Henrissat B, Leclerc M, Doré J, Monsan P, Remaud-Simeon M, Potocki-

- Veronese G (2010) Functional metagenomics to mine the human gut microbiome for dietary fiber catabolic enzymes. *Genome Res* 20(11):1605–1612
- Taylor M, Marmer W, Brown E (2007) Evaluation of polymers prepared from gelatin and casein or whey as potential fillers. *J Am Leather Chem Assoc* 102(4):111–120
- Thomsen MH, Holm-Nielsen JB, Oleskowicz-Popiel P, Thomsen AB (2008) Pretreatment of whole-crop harvested, ensiled maize for ethanol production. *Appl Biochem Biotechnol* 148:23–33
- Travis J, Potempa J, Maeda H (1995) Are bacterial proteinases pathogenic factors? *Trends Microbiol* 3(10):405–407
- Treichel H, Oliveira D, Mazutti MA, Di Luccio M, Oliveira JV (2010) A review on microbial lipases production. *Food Bioprocess Technol* 3:182–186
- Trivelli X, Krimm I, Ebel C, Verdoucq L, Prouzet-Mauléon V, Chartier Y, Tsan P, Lauquin G, Meyer Y, Lancelin JM (2003) Characterization of the yeast peroxiredoxin Ahp1 in its reduced active and overoxidized inactive forms using NMR. *Biochemistry* 42(48):14139–14149
- Trujillo M, Mauri P, Benazzi L, Comini M, De Palma A, Flohé L, Radi R, Stehr M, Singh M, Ursini F, Jaeger T (2006) The mycobacterial thioredoxin peroxidase can act as a one-cysteine peroxiredoxin. *J Biol Chem* 281(29):20555–20566
- Turner P, Mamo G, Karlsson EN (2007) Potential and utilization of thermophiles as thermostable enzymes in biorefining. *Microb Cell Fact* 6:1–23
- Van der Maarel MJ, Van der Veen B, Uitendaal JC, Leemhuis H, Dijkhuizen L (2002) Properties and applications of starch-converting enzymes of the α -amylase family. *J Biotechnol* 94:137–155
- Vermelho AB, De Simone SG, d'Avila-Levy CM, Santos ALS, Melo ACN, Silva FP Jr, Bon EPS, Branquinha MH (2007) Trypanosomatidae peptidases: a target for drugs development. *Curr Enzyme Inhib* 3:19–48
- Vermelho AB, Nogueira de Melo AC, Branquinha MH, Santos AL, D'Avila-Levy CM, Couri S, Bon EPS (2008) Enzimas proteolíticas: Aplicações Biotecnológicas. In: Bon EPS, Corvo L, Vermelho AB, Paiva CLA, Ferrara MA, Coelho RR, Alencastro RB (eds) *Enzimas em Biotecnologia: Produção, Aplicações e Mercado*. Interciência, Brasil, pp 269–286
- Vignardet C, Guillaume YC, Michel L, Friedrich J, Millet J (2001) Comparison of two hard keratinous substrates submitted to the action of a keratinase using an experimental design. *Int J Pharm* 224:115–122
- Volken de Souza CF, de Matos GSF, Hickmann MA, Ayub Z (2009) Environmental effects on transglutaminase production and cell sporulation in submerged cultivation of *Bacillus circulans*. *Appl Biochem Biotechnol* 158:302–312
- Waeonukul R, Kyu KL, Sakka K, Ratanakhanokchai K (2009) Isolation and characterization of a multienzyme complex (cellulosome) of the *Paenibacillus curdolanolyticus* B-6 grown on Avicel under aerobic conditions. *J Biosci Bioeng* 107(6):610–614
- Wang JJ, Greenhut WB, Shih JCH (2005) Development of an asporogenic *Bacillus licheniformis* for the production of keratinase. *J Appl Microbiol* 98:761–767
- Wang JJ, Garlich JD, Shih JCH (2006) Beneficial effects of Versazyme® a keratinase feed additive, on body weight, feed conversion and breast yield of broiler chickens. *J Appl Poultry Res* 15:544–550
- Wang A, Zhang F, Chen F, Wang M, Li H, Zeng Z, Xie ZT, Chen Z (2011) A facile technique to prepare cross-linked enzyme aggregates using p-benzoquinone as cross-linking agent. *Korean Journal of Chemical Engineering* 28: 1090–1095
- Watanabe K (2004) Collagenolytic proteases from bacteria. *Appl Microbiol Biotechnol* 63:520–526
- Wei H, Xu Q, Taylor LE II, Baker JO, Tucker MP, Ding S-Y (2009) Natural paradigms of plant cell wall degradation. *Curr Opin Biotechnol* 20: 330–338
- Wilson DB, Irwin DC (1999) Genetics and properties of cellulases. *Adv Biochem Eng Biotechnol* 65:1–21
- Władyska B, Pustelny K (2008) Cellular and molecular biology letters. *Biol Lett* 13:212–229
- Wohlgemuth R (2010) Biocatalysis key to sustainable industrial chemistry. *Curr Opin Biotechnol* 21:713–724
- Yakimov MM, Timmis KN, Wray V, Fredrickson HL (1995) Characterization of a new lipopeptide surfactant produced by thermotolerant and halotolerant subsurface *Bacillus licheniformis* BAS50. *Appl Environ Microbiol* 61: 1706–1713
- Yamamura S, Yasutaka M, Quamrul H, Yokoyama K, Tamiya E (2002) Keratin degradation: a cooperative action of two enzymes from *Stenotrophomonas* sp. *Biochem Biophys Res Commun* 294:1138–1143
- Yang MT, Chang CH, Wang JM, Wu TK, Wang K, Chang CY, Li TT (2011) Crystal structure and inhibition studies of transglutaminase from *Streptomyces mobaraense*. *J Biol Chem* 286(9):7301–7307
- Yokoyama K, Kikuchi NY (2004) Properties and applications of microbial transglutaminase. *Appl Microbiol Biotechnol* 64:447–454
- Yoshioka M, Miwa T, Horii H, Takata M, Yokoyama T, Nishizawa K, Watanabe M, Shinagawa M, Muruyama Y (2007) Characterization of a proteolytic enzyme derived from a *Bacillus* strain that effectively degrades prion protein. *J Appl Microbiol* 102(2):509–515
- Yu YJ, Wu SC, Chan HH, Chen YC, Chen ZY, Yang MT (2008) Overproduction of soluble recombinant transglutaminase from *Streptomyces netropsis* in *Escherichia coli*. *Appl Microbiol Biotechnol* 81:523–532
- Yu S, Yu S, Han W, Wang H, Zheng B, Feng Y (2010) A novel thermophilic lipase from *Fervidobacterium nodosum* Rt17-B1 representing a new subfamily of bacterial lipases. *J Mol Catal B: Enzym* 66:81–89
- Yu YH-R, Li Y-XZ, Chen B (2011) Bacterial diversity and bioprospecting for cold-active hydrolytic enzymes from culturable bacteria associated with sediment from Nella Fjord, Eastern Antarctica. *Mar Drugs* 9:184–195
- Yue XY, Zhang B, Jiang DD, Liu YJ, Niu TG (2011) Separation and purification of a keratinase as pesticide against root-knot nematodes. *World J Microbiol Biotechnol* 27(9):2147–2153
- Yurimoto H, Maiko Y, Yoshimi K, Hiroshi M, Nobuo K, Yasuyoshi S (2004) The pro-peptide of *Streptomyces mobaraensis* transglutaminase functions in cis and in trans to mediate efficient secretion of active enzyme from methylotrophic yeasts. *Biosci Biotechnol Biochem* 68:2058–2069
- Zaldivar J, Nielsen J, Olsson L (2001) Fuel ethanol production from lignocellulose: a challenge for metabolic engineering and process integration. *Appl Microbiol Biotechnol* 56:17–34
- Zeeman SC, Kossmann J, Smith AM (2010) Starch: its metabolism, evolution, and biotechnological modification in plants. *Annu Rev Plant Biol* 61:209–234
- Zhang Y-HP (2008) Reviving the carbohydrate economy via multi-product lignocelluloses biorefineries. *J Ind Microbiol Biotechnol* 35:367–375
- Zhang C, Kim S-K (2010) Research and application of marine microbial enzymes: status and prospects. *Mar Drugs* 8:1920–1934
- Zhang J, Masui Y (1997) Role of amphibian egg transglutaminase in the development of secondary cytostatic factor in vitro. *Mol Reprod Dev* 47:302–311
- Zhang Y-HP, Himmel ME, Mielenz JR (2006) Outlook for cellulase improvement: screening and selection strategies. *Biotechnol Adv* 24:452–481
- Zhang X-Z, Heng Y, Zhang P (2010) One-step production of biocommodities from lignocellulosic biomass by recombinant cellulolytic *Bacillus subtilis*: opportunities and challenges. *Eng Life Sci* 10:398–406
- Zhao J, Ding GH, Tao L, Yu H, Yu ZH, Luo JH, Cao ZW, Li YX (2007) Modular co-evolution of metabolic networks. *BMC Bioinformatics* 8:311–322
- Zhu Y, Tramper J (2008) Novel applications for microbial transglutaminase beyond food processing. *Trends Biotechnol* 26(10):559–565
- Zock J, Cantwell C, Swartling J, Hodges R, Pohl T, Sutton K, Rostek P, McGilvray D, Queener S (1994) The *Bacillus subtilis* *pnbA* gene encoding p-nitrobenzyl esterase: cloning, sequence and high-level expression in *Escherichia coli*. *Gene* 151:37–43
- Zubieta C, Joseph R, Krishna SS, McMullan D, Kapoor M, Axelrod HL, Miller MD, Abdubek P, Acosta C, Astakhova T, Carlton D, Chiu HJ, Clayton T, Deller MC, Duan L, Elias Y, Elsliger MA, Feuerhelm J, Grzechnik SK, Hale J, Han GW, Jaroszewski L, Jin KK, Klock HE, Knuth MW, Kozbial P, Kumar A, Marciano D, Morse AT, Murphy KD, Nigoghossian E, Okach L, Oommachen S, Reyes R, Rife CL, Schimmel P, Trout CV, van den Bedem H, Weekes D, White A, Xu Q, Hodgson KO, Wooley J, Deacon AM, Godzik A, Lesley SA, Wilson IA (2007) Identification and structural characterization of heme binding in a novel dye-decolorizing peroxidase. *TyrA*. *Proteins* 69:234–243
- Zverlov VV, Schwarz WH (2008) Bacterial cellulose hydrolysis in anaerobic environmental subsystems—*Clostridium thermocellum* and *Clostridium stercorarium*, thermophilic plant-fiber degraders. *Ann N Y Acad Sci* 1125:298–307

8 Bacteria in Food and Beverage Production

Michael P. Doyle¹ · Larry R. Steenson² · Jianghong Meng³

¹Department of Food Science & Technology, University of Georgia, Griffin, GA, USA

²Dupont Nutrition and Health, New Century, KS, USA

³Department of Nutrition and Food Science, University of Maryland, College Park, MD, USA

Introduction	242	Probiotic Bacteria and Competitive Exclusion	253
		Probiotic Bacteria in Food	253
Classification of Bacteria in Food and Beverage Products	243	Competitive Exclusion Concept	254
Other Bacteria	243	Competitive Exclusion of Foodborne Pathogens	254
		Prospects	254
Fundamental Metabolism	243		
Carbohydrate Metabolism	245	Abstract	
Proteolysis	245	Foods typically contain a variety of bacteria of which some may be beneficial, such as those preserving foods through products of fermentation, and others may be harmful by causing human illness or food spoilage. Lactic acid bacteria are among the most important groups of microorganisms used in food fermentations and are largely included in the genera <i>Carnobacterium</i> , <i>Enterococcus</i> , <i>Lactobacillus</i> , <i>Lactococcus</i> , <i>Leuconostoc</i> , <i>Oenococcus</i> , <i>Pediococcus</i> , <i>Streptococcus</i> , <i>Tetragenococcus</i> , <i>Vagococcus</i> , and <i>Weissella</i> . The essential feature of lactic acid bacteria metabolism is efficient carbohydrate fermentation coupled to substrate-level phosphorylation. These bacteria can degrade a variety of carbohydrates, with lactic acid being the predominant end product. Many lactic acid bacteria also produce bacteriocins that have antimicrobial activity that is antagonistic to other bacteria, especially toward bacteria closely related to the bacteriocin-producing strain. Bacteriocins are peptides that are produced ribosomally by bacteria and released extracellularly.	
Bacteriocin Production	246	Starter cultures, which are largely comprised of lactic acid bacteria, are food-grade microorganisms that are used to produce fermented foods of desirable appearance, body, texture, and flavor. Types of fermented foods for which commercial starter cultures are currently used include dairy products (cheese, sour cream, yogurt), meat products (sausages), and vegetable products (pickles, sauerkraut, olives). For starter cultures to be effective during food fermentations, they must dominate over naturally occurring microflora and produce the desired end products of fermentation. Many of the activities essential for food fermentations, including lactose metabolism, proteinase activity, oligopeptide transport, bacteriophage-resistance mechanisms, bacteriocin production and immunity, bacteriocin resistance, exopolysaccharide production, and citrate utilization, are encoded on plasmids harbored by lactic acid bacteria. Advances in molecular technology have enabled the construction of superior strains of starter cultures for food fermentations. Improved features of these strains include	
Biopreservation of Food	247		
Protective Cultures	247		
Fermentates	248		
Starter Cultures	248		
Development of Starter Cultures	248		
General Requirements for Starter Cultures	248		
Safety	248		
Technological Effectiveness	248		
Economic Aspects	249		
Genetics of LAB Starter Cultures	249		
Starter Culture Improvement	249		
Bacteriophage and Bacteriophage Resistance	249		
Flavor Production	250		
Commercial Application	250		
Dairy Products	250		
Cultured Butter and Buttermilk	250		
Yogurt	251		
Cheese	251		
Meat Products	251		
Vegetable and Fruit Products	252		
Sauerkraut	252		
Cucumber Pickles	252		
Olives	252		
Vinegar	253		
Malolactic Fermentation in Wine	253		
Indigenous Fermented Beverages	253		

bacteriophage resistance, genetic stability, and reduced variation and unpredictability in performance.

Another application for beneficial microbes used in foods is adding probiotic microorganisms to provide a health benefit to consumers. Many beneficial health effects for probiotics have been reported and include protection against enteric pathogens, improved digestion by means of enzymes to metabolize otherwise indigestible food nutrients (e.g., lactase to hydrolyze lactose in lactose intolerant consumers), stimulation of the intestinal immune system, and improvement of intestinal peristaltic activity. Lactic acid bacteria are the most common types of probiotic microbes being used. Probiotics have been largely delivered in fermented foods such as yogurt and fermented milk products; however, growing consumer interest in probiotics is leading to using other types of foods such as fruit and vegetable juices, cereal-based products, and even ice cream, as delivery vehicles.

Fermented foods are an important part of the food processing industry and of many consumers' diets and are largely produced by lactic acid bacteria that have been selected for their ability to produce desired products or changes in the food. Many advances have been made during the past decade in developing improved bacterial strains for starter culture application, which largely have been made possible through advances in molecular technology. The use of lactic acid bacteria to enhance the quality and safety of foods is a rapidly evolving field. With the discovery of new bacteriocins and the development of more efficient approaches to deliver them to foods, the importance of lactic acid bacteria in preserving and providing enhanced safety of food will continue to increase for the foreseeable future.

Introduction

Foods are plants and animals (or their products), and each often contains many types of microorganisms. These microbes from natural and external sources contaminate foods by contact, which can occur anytime between production and consumption. Microbial contamination of foods can have many undesirable consequences ranging from spoilage to foodborne illness. However, some microorganisms possess properties that can benefit food production or conversion. Many food-grade microorganisms are used to produce a variety of fermented foods from raw animal and plant materials. The acidic, and in part organoleptic, properties of fermented products result from the fermentative activities of these microorganisms. Foods such as ripened cheeses, fermented sausages, sauerkraut, and pickles have not only a greatly extended shelf life compared to the raw materials from which they are derived, but also aroma and flavor characteristics contributed directly or indirectly by the fermenting organisms. Consumption of fermented food product has increased dramatically during the last two decades and will continue to increase. The production and availability of fermentative microorganisms (starter cultures) used in food conversion have advanced to meet this demand. This includes the development of novel and better strains through genetic engineering.

Lactic acid bacteria (LAB) are among the most important groups of microorganisms used in food fermentations. LAB contribute to the taste and texture of fermented products and inhibit food spoilage bacteria by producing growth-inhibitory substances (bacteriocins) and large amounts of lactic acid, and other organic acids. Many LAB benefit human and animal health, whereas others spoil beer, wine, and processed meats. They can be isolated from the respiratory, intestinal, and genital tracts of humans and animals and from plants.

Fermented dairy products have been made for thousands of years, but only within the last century has the microbiological basis of these fermentations been elucidated and that LAB are the principal organisms involved in fermenting dairy products. Prior to the availability of starter cultures, milk fermentations relied on the LAB naturally present in raw milk. The first commercial starter cultures, unknown mixes of strains most likely from raw milk, were prepared in Denmark just before the end of the nineteenth century. In the 1930s and 1940s, the concept of pure single-strain starter cultures evolved, and bacteriophage were identified as important agents of slow fermentation in cheese. With their development in the 1960s and 1970s, concentrated (often frozen or freeze-dried) starter cultures could be inoculated directly into the bulk starter vessel without the need for prior preparation in the creamery. In the last two decades, major advances on dairy starter technology have included improved culture selection procedures that enhance bacteriophage resistance. Molecular technology has been applied to map the genetic constructs of starter culture organisms and, by using plasmid/gene transfer mechanisms, to improve starter culture performance.

Sausage is one of the oldest processed meat products. The writings of ancient Egyptians described the preservation of meat by salting and sun drying. The ancient Babylonians, Greeks, and Romans used sausage as a food source during times of war. Microorganisms were recognized as being important to the production of sausages at about 1921. In the 1940s and 1950s, pure microbial starter cultures became available to processors, and in 1968, frozen culture concentrates became commercially available to the meat industry. Use of these cultures was not widespread until the early 1980s largely because producers clung to the traditional methods of making sausage (using previously fermented meat as the source of LAB) and feared they might lose the quality and consumer acceptance of their final product. Today the importance of the use of starter cultures is recognized in most countries.

The fermentation of vegetables, a practice that originated in the Orient, has been used as a means of preserving food for more than 2,000 years. In the third century B.C. during the construction of the Great Wall of China, the Chinese produced fermented vegetables (cabbages, radishes, turnips, cucumbers, etc.) on a large scale. The most common fermented vegetables available in the United States are pickles, sauerkraut, and olives. Carrots, cauliflower, celery, okra, onions, and sweet and hot peppers also are sold as fermented vegetable products.

Currently, more than 2,000 different fermented foods are consumed by humans worldwide; many are ethnic and produced in small quantities to meet the demand of a group in

a particular region. Some are produced commercially and only a few by large commercial food processors. As consumers' interest in natural and health foods increases, future consumption of fermented foods also will increase significantly worldwide.

Classification of Bacteria in Food and Beverage Products

The classical approach to bacterial classification is based on morphological and physiological features. LAB are gram-positive, nonsporeforming cocci, coccobacilli, or rods with a DNA base composition of less than 50 mol% G+C (Stiles and Holzapfel 1997). They generally lack catalase and ferment glucose mainly to lactic acid (homofermentative) or to lactic acid, CO₂, and ethanol or acetic acid or both (heterofermentative). The importance of LAB in the fermentation of food products (dairy, meat, vegetables, fruits, and beverages) has been used as a basis to differentiate the group, although some are also members of normal flora of the mouth, intestine, and vagina of mammals (Klein et al. 1998). Therefore, LAB associated with food are generally restricted to the genera *Carnobacterium*, *Enterococcus*, *Lactobacillus*, *Lactococcus*, *Leuconostoc*, *Oenococcus*, *Pediococcus*, *Streptococcus*, *Tetragenococcus*, *Vagococcus*, and *Weissella*. Table 8.1 shows differential characteristics of LAB at the genus level (Axelsson 1998). Bacterial taxonomic classification has been expanded recently to include cell wall composition (de Ambrosini et al. 1996), cellular fatty acids (Gilarova et al. 1994), isoprenoid quinones and other characteristics of cells (Stiles and Holzapfel 1997). Molecular characteristics also have become important taxonomic tools, such as electrophoretic properties of the gene products, DNA: DNA hybridization studies, and structures and sequence of ribosomal RNA (rRNA; Collins-Thompson et al. 1991; Makela et al. 1992; Stackebrandt and Teuber 1988; Vandamme et al. 1996). The 16S rRNA data for LAB suggest new groupings that cross the established taxonomic lines. Not all of the new groupings have become established in bacterial taxonomy, but recent phylogenetic considerations indicate that the lactobacilli, *Leuconostocs* and *Pediococci* can be reclassified as three major groups: the *Leuconostoc* group, the *Lactobacillus delbrueckii* group, and the *Lactobacillus casei*-*Pediococcus* group. The newly established genera *Carnobacteria*, *Tetragenococcus* (previously *Pediococcus halophilus*) and *Vagococcus* (previously motile streptococci) form a phylogenetic cluster with the genus *Enterococcus* (Vandamme et al. 1996). However, generally LAB that are important to food microbiology include only certain species of the genera *Lactobacillus*, *Lactococcus* (*Streptococcus*), *Leuconostoc*, and *Pediococcus* (Stiles and Holzapfel 1997). The genus *Lactobacillus* is by far the largest of the genera included in LAB. It is also very heterogeneous, encompassing species with a large variety of phenotypic, biochemical, and physiological properties.

Based on sugar fermentation patterns, LAB can be further divided into three broad metabolic categories (Axelsson 1998). The first category includes the group I lactobacilli and some

individual species from other genera that are obligately homofermentative, meaning the sugars can only be fermented by glycolysis. The second category includes *leuconostocs*, group III lactobacilli, *oenococci*, and *weissellas* that are obligately heterofermentative, meaning that only the 6-phosphogluconate/phosphoketolase (6-PG/PK) pathway is available for sugar fermentation. The apparent difference on the enzyme level between these two categories is the presence or absence of the key enzymes of glycolysis and the 6-PG/PK pathway. The third category, including the remaining LAB (i.e., group II lactobacilli and most species of *enterococci*, *lactococci*, *pediococci*, *streptococci*, *tetragenococci*, and *vagococci*), holds an intermediate position. They resemble the obligately homofermentative LAB in that they possess a constitutive fructose-1,6-diphosphate aldolase, resulting in the use of glycolysis form hexose fermentation.

Other Bacteria

In addition to LAB, other bacteria also are involved in food fermentations, some of which contribute significantly to flavor development and other characteristics of fermented products. Propionibacteria are probably best known for their role as dairy starter cultures, in which they produce the characteristic eyes and flavor of Swiss-type cheeses (Cogan and Accolas 1996). The family Propionibacteriaceae, genus *Propionibacterium* and the closely related genus *Corynebacterium*, are classified as members of the Actinomycetaceae group. Five species of dairy Propionibacteria are currently recognized: *P. freudenreichii* subsp. *freudenreichii*, *P. freudenreichii* subsp. *shermanii*, *P. thoenii*, *P. acidipropionici*, and *P. jensenii*. In addition to being important starter organisms in dairy fermentations, Propionibacteria also contribute to natural fermentations of silage and olives and can produce a variety of industrially important products (Jay et al. 2007).

Acetobacters are gram-negative aerobic rods and cocci and consist of three species, *Acetobacter aceti*, *A. pasteurianus*, and *A. peroxydans* (Lee 1996). The organisms are widely distributed in nature where they are abundant in plant materials undergoing alcoholic fermentations. They are important for their role in the production of vinegar.

Fundamental Metabolism

The essential feature of LAB metabolism is efficient carbohydrate fermentation coupled to substrate-level phosphorylation. The generated adenosine triphosphate (ATP) is subsequently used for biosynthetic purposes. LAB as a group exhibit an enormous capacity to degrade different carbohydrates and related compounds. Generally, the predominant end product is lactic acid (>50 % of sugar carbon). However, LAB adapt to various conditions and change their metabolism accordingly. This may lead to significantly different end product patterns.

Table 8.1
Differential characteristics of lactic acid bacteria at the genus level based on morphology and physiology

Characteristic	Rods			Cocci							
	<i>Carnobacterium</i>	<i>Lactobacillus</i>	<i>Enterococcus</i>	<i>Lactococcus Vagococcus</i>	<i>Leuconostoc Oenococcus</i>	<i>Pediococcus</i>	<i>Streptococcus</i>	<i>Tetragenococcus</i>	<i>Weissella</i> ^a		
Tetrad formation	–	–	–	–	–	+	–	+	–		
CO ₂ from glucose ^b	± ^c	±	–	–	+	–	–	–	+		
Growth:											
At 10 °C	+	±	+	+	+	±	–	+	+		
At 45 °C	–	±	+	–	–	±	±	–	–		
In 6.5 % NaCl	ND ^d	±	+	–	±	±	–	+	±		
In 18 % NaCl	–	–	–	–	–	–	–	+	–		
At pH 4.4	ND	±	+	±	±	+	–	–	±		
At pH 9.6	–	–	+	–	–	–	–	+	–		
Lactic acid ^e	L	D, L, DL	L	L	D	L, DL	L	L	D, DL		

+ positive, – negative, ± response varies between species, ND not determined

^aMay also be rods

^bTest for homo- or heterofermentation of glucose; + homofermentation, – heterofermentation

^cSmall amounts of CO₂ can be produced

^dNo growth in 8 % NaCl has been reported

^eConfiguration of lactic acid produced from glucose

Modified from Axelsson (1998)

Carbohydrate Metabolism

LAB, as nonrespiring microorganisms, principally generate ATP by fermentation of carbohydrates coupled to substrate-level phosphorylation. Many compounds can serve as fermentable growth substrates, and many pathways for their fermentation have evolved (Kandler 1983). These pathways have the following three general stages (Thompson 1988): (1) conversion of the fermentable compound to the phosphate donor for substrate phosphorylation—this stage often contains metabolic reactions in which NAD^+ is reduced to NADH ; (2) phosphorylation of ADP by the energy-rich phosphate donor; (3) metabolic steps that bring the products of the fermentation into chemical balance with the starting materials. The most frequent requirement in the last stage is a mechanism for oxidation of NADH , generated in the first stage of fermentation, to NAD^+ so that the fermentation can proceed. The two major pathways for metabolism of hexose in lactic acid bacteria are the homofermentative (Embden-Meyerhof) and heterofermentative (phosphoketolase) pathways (► Figs. 8.1 and 8.2). The transport and phosphorylation of sugars occur according to the following metabolisms: transport of free sugar and phosphorylation by an ATP-dependent glucokinase for glucose; other sugars, such as mannose and fructose, enter the major pathways at the level of glucose-6-phosphate or fructose-6-phosphate after isomerization or phosphorylation or both (Axelsson 1998). One exception is galactose metabolism in LAB which use the phosphoenolpyruvate:sugar phosphotransferase system (PTS) for uptake of this sugar. Some species of LAB use this system for all sugars, in which phosphoenolpyruvate is the phosphoryl donor.

Proteolysis

LAB have a very limited capacity to synthesize amino acids using inorganic nitrogen sources (Mayo 1993). They are, therefore, dependent on preformed amino acids being present in the growth medium as a source of nitrogen. The requirement for amino acids differs among species and strains within species (Chebbi et al. 1977). Some strains are prototrophic for most amino acids, whereas others may require 13–15 amino acids. The quantities of free amino acids present in food often are not sufficient to support the growth of bacteria to a high cell density; therefore, they require a proteolytic system capable of utilizing the peptides and proteins present in food that hydrolyzes proteins to obtain essential amino acids. All dairy lactococci used for acidification of milk (e.g., in cheese manufacture) have proteolytic activity (Poolman et al. 1995). The lactococcal proteolytic system consists of enzymes outside the cytoplasmic membrane, transport systems, and intracellular enzymes. The transport systems on the cell membrane include oligopeptide transport, di-/tripeptide transport, and amino acid transport systems (► Fig. 8.3; Pritchard and Coolbear 1993). The transport of free amino acids contributes very little to the total growth of lactococci in milk. Two general classes of proteolytic enzymes

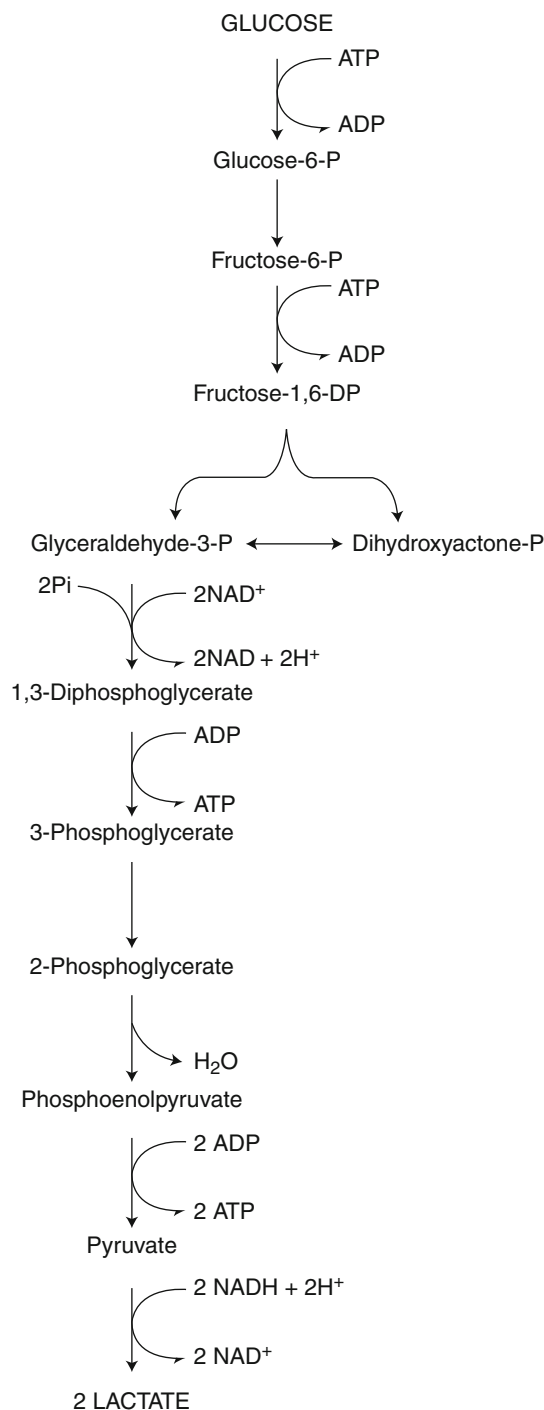

■ Fig. 8.1 Homolactic fermentation pathway of glucose (glycolysis, Embden-Meyerhof pathway)

of LAB are proteinases and peptidases. An extracellular, membrane-anchored serine proteinase (PrtP) has been identified as being essential for this activity. Once inside the cell, peptides are hydrolyzed by peptidases.

The proteolytic activity also contributes to the development of the flavor and rheological characteristics of fermented

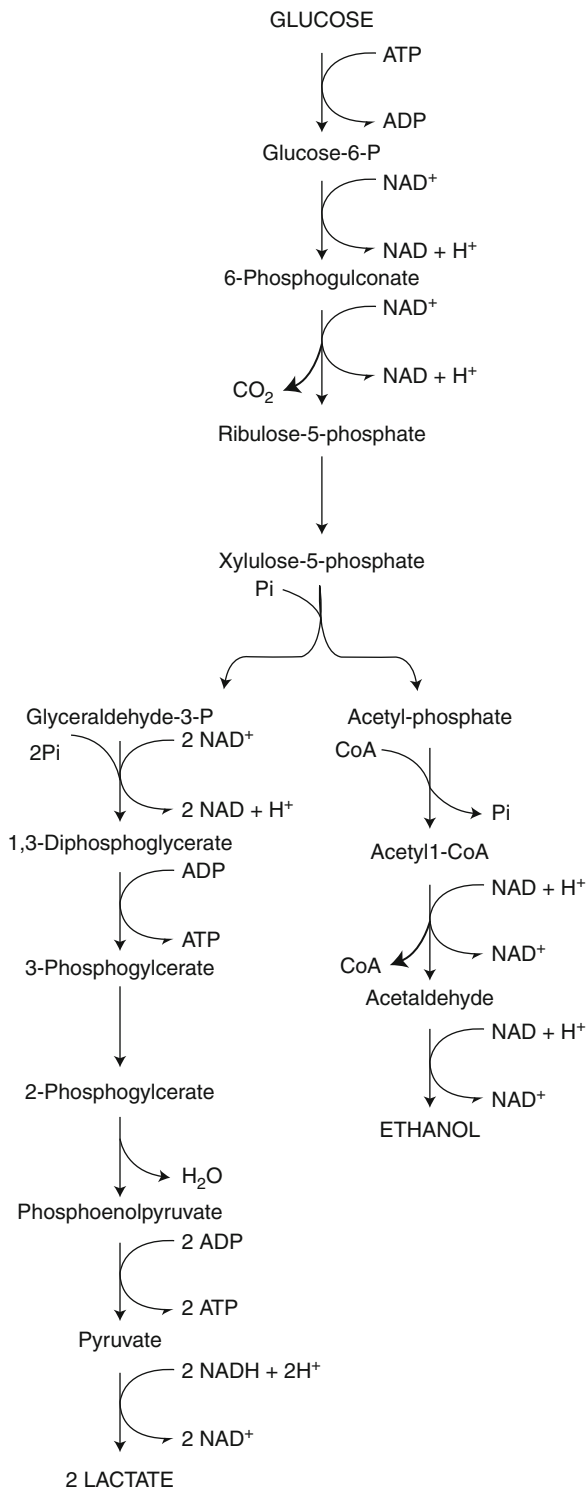

Fig. 8.2
Heterolactic fermentation pathway of glucose
(6-phosphogluconate/phosphoketolase pathway)

products (Mayo 1993). For many varieties of cheeses, such as Swiss and Cheddar, desirable flavor tones are derived by proteolysis. However, proteolysis also can lead to undesirable flavors due to the accumulation of bitter peptides.

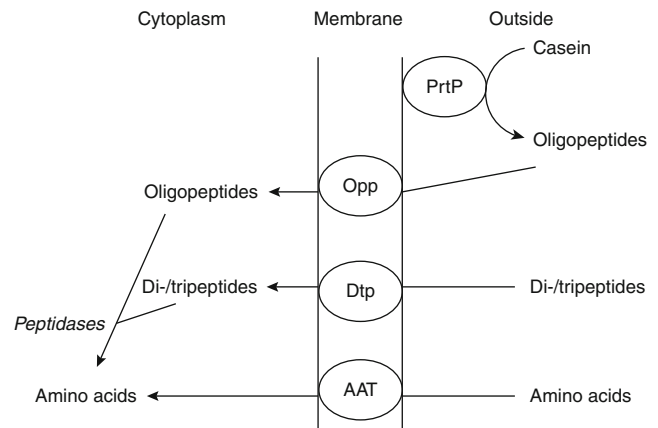

Fig. 8.3
Model of the lactococcal proteolytic system. Included also is transport of di- and tripeptides and free amino acids, but they contribute very little to the total growth of Lactococci. PrtP membrane-anchored proteinase, Opp oligopeptide transport system, Dtp di-/tripeptide transport system, AAT amino acid transport system.

Bacteriocin Production

Bacteriocins, antimicrobials produced by bacteria, were described more than 50 years ago (Heng and Tagg 2006), and interest in their use for food safety and spoilage applications in food generally began upon their discovery in LAB. Bacteriocins are peptides that are synthesized ribosomally by bacteria and released extracellularly. They are antagonistic to other bacteria, most often those closely related to the producer strain (Leroy and De Vuyst 2010). Several have been identified that have broad host ranges, typically against Gram-positive bacteria. Producer cells have specific immunity to their bacteriocin(s). Interest in bacteriocins produced by LAB accelerated in the 1980s, and research activities have continued unabated to this day, with new bacteriocins continually being discovered and described. Klaenhammer (1993) outlined a classification scheme to describe LAB bacteriocins. There are four distinct classes in this scheme: (I) lantibiotics, (II) small, heat-stable, non-lanthionine-containing membrane-active peptides (with three subgroups), (III) large, heat-labile proteins, and (IV) complex bacteriocins, composed of protein plus one or more chemical moieties. Although other classification schemes have been proposed since 1993, with the goal of having more universal definitions (Cotter et al. 2005; Heng and Tagg 2006), Klaenhammer's classification is still relevant for bacteriocins of LAB. This classification is listed in Table 8.2.

Recently, bacteriocins produced by LAB and associated bacteria have been identified that exhibit expanded host ranges, specifically with added activities against Gram-negative bacteria (Svetoch and Stern 2010; Lee et al. 2011). Both class I and class IIa bacteriocins have been identified.

■ Table 8.2

Classes of bacteriocins produced by lactic acid bacteria

Class	Subclass	Description	Bacteriocin producer
I		Lantibiotics	<i>Carnobacterium</i> , <i>Enterococcus</i> , <i>Leuconostoc</i> , <i>Lactobacillus</i> , <i>Streptococcus</i>
II		Small (<10 kDa), heat stable (100–121 °C)	<i>Carnobacterium</i> , <i>Enterococcus</i> , <i>Leuconostoc</i> , <i>Lactobacillus</i> , <i>Streptococcus</i>
	IIa	<i>Listeria</i> -active peptides	
	IIb	Two-peptide bacteriocins	
	IIc	Thiol-activated peptides	
III		Large (>30 kDa) heat-labile proteins	<i>Lactobacillus</i>
IV		Complex bacteriocins: protein with lipid and/or carbohydrate	<i>Lactobacillus</i> , <i>Leuconostoc</i> , <i>Pediococcus</i>

(I) Lantibiotics, or lanthionine-containing peptides, generally less than 5 kDa, which are membrane active. These peptides contain the unusual amino acids lanthionine, β -methyl lanthionine, and dehydrated residues. They can be further subdivided into type A (linear) and type B (globular). Nisin (type A) is the most well-known lantibiotic, and the only purified bacteriocin approved for use in food as a biopreservative (Leroy and De Vuyst 2010). Other lantibiotics include lactacin 481, carnocin U149, and lactocin S. Nisin's mode of action has been elucidated and involves binding to the specific target lipid II cell wall precursor while still anchored to the cell membrane and pore formation, resulting in membrane disruption (Wiedemann et al. 2001; Breukink and de Kruiff 2006)

(II) Small heat-stable non-lanthionine-containing peptides of less than 10 kDa in size that are membrane active and act to disrupt bacterial membranes. Subgroups include the following:

(a) *Listeria*-active (pediocin-like) peptides with the homologous region in the N-terminal of YGNVXCXXXXCXV, with the two cysteine residues forming a disulfide bridge (pediocin PA-1, sakacin A, leucocin A, others; Deegan et al. 2006)

(b) Two-peptide bacteriocins forming poration complexes (lactococcins G and M, lactacin F)

(c) Thiol-activated peptides requiring reduced cysteine residues for activity (lactococcin B)

(III) Large heat-labile proteins greater than 30 kDa in size (helveticins J and V, others)

(IV) Complex bacteriocins composed of proteins plus one or more chemical moieties such as lipid or carbohydrate (plantaricin S, pediocin SJ-1, others)

Biopreservation of Food

While LAB bacteriocins can be powerful interventions against foodborne pathogens and spoilage organisms, other metabolites useful for this purpose are also produced by LAB and associated bacteria such as *Propionibacterium* and *Bifidobacterium*. These include organic acids (lactic, acetic, propionic, formic, phenyllactic, etc.), diacetyl, acetoin, reuterin, reutericyclin, peroxides, and many more, both identified and unidentified (Leroy and De Vuyst 2010). Because of their general acceptability in food, these bacteria are rich sources of potential antimicrobials for specific food and feed applications. With the increasing desire by the food industry to deliver more “natural” foods to consumers (along with increasing demand for these foods by consumers), interest in replacing chemical preservatives with natural alternatives (biopreservatives) is growing. Bacteriocins and other metabolites produced by LAB are logical alternatives. Antimicrobial activity from LAB can be delivered to food systems in a number of ways. Purified bacteriocins such as nisin are already used in the food industry for food safety applications (*Listeria*, sporeformers) and prevention of spoilage by LAB (Leroy and De Vuyst 2010; Delves-Broughton et al. 1996). Other bacteriocins with broad host ranges could conceivably be purified and delivered in similar fashion. However, two alternative delivery systems are available, which preclude purification of specific bacteriocins or other metabolites, thus increasing speed to market. These are use of living cultures to deliver the desired antimicrobial effect to foods as protective

cultures (Jones et al. 2011) and the use of raw (unpurified) concentrates (fermentates) obtained by the cultivation of the antimicrobial strain in food-grade substrates, such as milk, whey, or dextrose (Galvez et al. 2007; Weber et al. 2008). Jones et al. (2011) defined seven desirable criteria for biopreservative agents. These are (1) nontoxic, (2) regulatory approved (GRAS, Generally Recognized as Safe), (3) low cost, (4) no negative organoleptic effects, (5) effective in low concentrations, (6) stable at storage conditions, and (7) no medical application.

Protective Cultures

Antimicrobial properties beyond basic fermentative capabilities of food-grade bacteria can be delivered to food products by living cells in the form of protective cultures. These properties are due to production of specific metabolites such as bacteriocins, bacteriocin-like inhibitory substances (BLIS; Jones et al. 2011), organic acids, or other compounds and may also be a result of other microbial interactions (competitive exclusion, quorum sensing). Protective cultures can be developed to inhibit specific target microorganisms such as yeast and mold or pathogens such as *Listeria monocytogenes*. As these cultures are viable, it is important that they contribute little or no undesirable sensory aspects to the food. For this reason, their use in food has generally been limited to cultured products, where they are typically added as adjunct cultures and have little effect on the finished product with regard to organoleptic properties.

Protective cultures for specific food safety and quality applications are available commercially, and are gaining in popularity as biopreservative agents in food.

Fermentates

Fermentates can be defined as raw concentrates obtained from cultivation of protective cultures in food-grade substrates such as milk or dextrose, which are subsequently inactivated by heat, condensed, and dried to produce substances that can be directly added to food as additives or ingredients (Galvez et al. 2007; Weber et al. 2008). Fermentates are convenient systems for delivering antimicrobial substances produced by GRAS microorganisms to food and, because there are no viable cells, have greater versatility than protective cultures. Their application can be expanded beyond cultured food products, where they have little or no sensory effects. Because they contain nonviable cells of the cultivated culture, they can also be considered as whole fraction fermentates (Weber et al. 2008). Fermentates have been utilized successfully to deliver bacteriocins, BLIS, organic acids, and other metabolites to target a host of undesirable microorganisms such as yeast, mold, spoilage LAB, and pathogens such as *L. monocytogenes* and *Salmonella*. Currently, there are several fermentates available commercially for use as biopreservatives in food.

Starter Cultures

Starter cultures are food-grade microorganisms of known and stable metabolic activities and other characteristics that are used to produce fermented foods of desirable appearance, body, texture, and flavor (Ray 1996). Starter cultures in manufacture of food products were used long before it was known that bacteria were involved at all. Initial development of starter cultures resulted from the need and changes in the cheese industry. Since the early 1900s, there has been a marked worldwide increase in the industrial production of fermented food products. Process technology has progressed toward greater mechanization, larger factory size, shorter processing times, and more food processed daily in the processing plant. All of this relies on the optimization of the starter culture's activity, whereby the culture must maintain stable fermentative properties and resistance to bacteriophage (Lee 1996). Currently, starter cultures for many types of fermented foods, including dairy products, meat products, vegetable products, and baking products, and for alcohol fermentation are commercially available.

Development of Starter Cultures

Starter cultures used in dairy products can be divided into mesophilic and thermophilic cultures based on their optimum growth temperature (▶ Table 8.3, Cogan and Accolas 1996). Mesophilic cultures grow at temperatures of 10–40 °C, with an

■ Table 8.3

Examples of mesophilic and thermophilic starter culture organisms used by the dairy industry

Type	Species
Mesophilic	<i>Lactococcus lactis</i> spp. <i>lactis</i>
	<i>Lactococcus lactis</i> spp. <i>cremoris</i>
	<i>Lactococcus lactis</i> spp. <i>lactis</i> var. <i>diacetylactis</i>
	<i>Leuconostoc lactis</i>
	<i>Leuconostoc cremoris</i>
Thermophilic	<i>Lactobacillus delbrueckii</i> spp. <i>lactis</i>
	<i>Lactobacillus helveticus</i>
	<i>Lactobacillus delbrueckii</i> spp. <i>bulgaricus</i>
	<i>Lactobacillus acidophilus</i>
	<i>Streptococcus thermophilus</i>

optimum of ca. 30 °C. Comprised of acid-forming lactococci as well as flavor-producing bacteria, these cultures are used to make a variety of cheeses, fermented milk products, and ripened cream butter. Thermophilic cultures have optimum temperatures of 40–50 °C and are used for yogurt and cheese varieties with high cooking temperatures. Starter cultures also have been used to produce meat products such as sausages and fermented vegetables. *Pediococcus acidilactici*, *Lactobacillus plantarum*, and/or *Staphylococcus carnosus* are often used as starter cultures in sausage production, whereas cabbage, cucumbers, and olives are fermented with *Lactobacillus plantarum*. Starter cultures, usually comprised of different species or of several strains of a single species, are often categorized on the basis of their composition (Ray 1996): (1) single-strain starter: one strain of a certain species, (2) multiple-strain starter (defined-strain starter): different known strains of one species, (3) multiple-mixed-strain starter: different defined strains of different species, and (4) raw mixed-strain starter: species and strains partly or all undefined. Mixed-strain starter cultures may also be phage carrying.

General Requirements for Starter Cultures

Safety

Starter cultures contain bacteria that lack virulence factors for humans and thus are free of pathogens and toxins (Buckenhuskes 1993).

Technological Effectiveness

Starter culture bacteria dominate over naturally occurring microflora. The microorganisms perform the required metabolic activities. Starter culture preparations are free of bacteriophage and microorganisms that may inhibit or reduce starter culture activity.

Economic Aspects

The propagation and production of starter cultures must be economically feasible. The starter culture can be preserved by freezing or freeze drying with little practical loss of activity. Essential properties of starter cultures such as fermentative ability are stable under defined storage conditions for several months.

Frozen concentrated starter cultures were developed in the 1970s for direct inoculation into substrates to be cultured. Efforts have been made to produce freeze-dried concentrated cultures, which have less bulk and do not require transport on dry ice, thereby eliminating the problem of accidental thawing. The dried cultures can be used directly for product manufacture or to produce bulk starters (Cogan and Accolas 1996). However, many starter culture strains do not survive well in the dried state. Hence, the care of dried cultures in large commercial operations has been limited. A recent advance has been the availability of custom-designed starter cultures to meet the specific needs of a food processor. An understanding of the genetic basis of both desirable fermentative characteristics as well as phage inhibition defenses of starter cultures has advanced the production of designer cultures.

Genetics of LAB Starter Cultures

The characterized genetic elements of LAB starter cultures include chromosomes, transposable elements, and plasmids (Gasson 1990; Rodriguez and Vidal 1990). Chromosomes of LAB are smaller than those of other eubacteria, ranging from 1.1 to 2.6 Mbp, depending on the species. Transposable elements, genetic elements capable of moving as discrete units from one site to another in the genome, have been identified in LAB. Insertion sequences, the simplest of transposable elements, are widely distributed in bacteria and also have been found in LAB. Their ability to mediate molecular rearrangements and affect gene regulation has had both positive and negative implications for food fermentations (Gasson 1990). Plasmids have been identified in many LAB. Some plasmids encode many of the activities essential for food fermentations (de Vos 1999), including lactose metabolism, proteinase activity, oligopeptide transport, bacteriophage-resistance mechanisms, bacteriocin production and immunity, bacteriocin resistance, exopolysaccharide production, and citrate utilization.

Natural gene transfer systems among LAB are largely transduction and conjugation, although transformation also has been reported as a means of genetic exchanges (Rodriguez and Vidal 1990). Transduction, the transfer of bacterial genetic material by a bacteriophage, has been demonstrated in lactococci, lactobacilli, and *Streptococcus thermophilus*. Usefulness of transduction in construction of strains for the fermentation industry is limited because of the relatively narrow host range of transducing bacteriophage. Conjugation, the transfer of genetic material from one bacterial cell to another, which requires cell-to-cell contact, has been well characterized in lactococci. Most plasmid-encoded characteristics important in the

manufacture of fermented dairy products can be transferred by conjugation. Using an approach that does not require antibiotic-resistance markers, conjugation has been used to transfer plasmids that encode bacteriophage-resistance genes into commercial lactococcal strains (Verrips and van den Berg 1996). These strains have enhanced resistance to infection by bacteriophage and have been used successfully in the dairy industry for years. Recent advances in molecular biology and functional genomics are providing a greater understanding of the genetics of LAB. Several genomes have been sequenced and annotated to date, and more are being added (Morelli et al. 2004).

Starter Culture Improvement

Past emphasis on starter culture improvement was largely based on screening natural isolates for traits of interest and monitoring existing strains to select for beneficial variations. More recently, advances in molecular technology have enabled us to understand more about the biology, physiology, and taxonomy of LAB and other microorganisms important to food fermentations (McKay and Baldwin 1990). In the future, it may be possible to definitively identify and then combine the most desirable nutritional, sensory, and/or therapeutic properties of starter cultures to construct “superior” strains for food fermentations (Geisen and Holzapfel 1996). At present, however, strain improvement focuses on eliminating problems that beset their use as starter cultures. Features such as bacteriophage infection, genetic instability, variation and unpredictability in performance, and the production of low-grade or poor-quality products all lead to economic losses. These are characteristics that have been examined extensively with interest in identifying and generating strains with superior attributes. Considerable research has been devoted to studying phage and phage-host interactions in LAB, the mechanisms by which lactose, citrate, and protein are metabolized and the basis for instability and unpredictability in strain performance. Also, because of their food-grade, nonpathogenic, Generally Recognized as Safe (GRAS) status, LAB are considered to be ideal hosts for the production of proteins and other compounds that they do not produce naturally and that have medical or food-related applications (Kuipers et al. 1997).

Bacteriophage and Bacteriophage Resistance

Food fermentations rely on actively growing LAB that either are added as starter cultures or grow spontaneously in the food matrix. The fermentation capabilities of LAB can be severely inhibited by bacteriophage infection, which has been a major commercial problem (Klaenhammer 1991). Bacteriophages are bacterial viruses that were first identified at the beginning of 1900 as “filter-transmissible” agents and were first described in LAB by Whitehead and Cox (1935). Significant progress has been made toward the characterization of bacteriophages from LAB. All of the bacteriophages examined contain double-stranded

linear DNA genomes with either cohesive or circularly permuted terminally redundant ends. Both lytic and temperate bacteriophages have been identified. Bacteriophage infection may lead to a decrease or complete inhibition of lactic acid production by the starter culture. This effect has had a major impact on the manufacture of fermented food products, as lactic acid synthesis is required to produce these products. In addition, slow acid production disrupts manufacturing schedules and typically results in products that are of lower economic value. In the past, strain rotation programs were developed to combat disturbances of dairy fermentations by bacteriophage and are still important today. However, bacteriophage resistance remains a very important characteristic of any industrial LAB strain, whether natural or genetically engineered (Klaenhammer 1991).

Selective environmental pressures placed on LAB by bacteriophages over thousands of years have resulted in strains that possess numerous bacteriophage defense mechanisms. The best-characterized bacteriophage-resistant LAB are lactococci (Dinsmore and Klaenhammer 1995; Sanders 1988). Phage defense mechanisms identified in lactococci include abortive infection mechanisms, the restriction-modification system, and interference with phage adsorption. Abortive phage infection is a powerful defense, acting after phage injection to decrease phage development efficiency and so reduce the number of emerging phages when the cell bursts. This mechanism effectively decreases phage replication rates and results in poor to no plaque formation on agar assays. The restriction-modification system is another common phage defense mechanism that reduces plaquing efficiencies of phages on normally permissive hosts by several log cycles. Such systems operate by coordinated activities of a restriction enzyme that recognizes and cleaves foreign DNA and a modification enzyme that labels DNA as host derived. These defense loci are encoded by plasmids capable of conjugal transfer, suggesting that genetic exchange between LAB has an important role in the development of bacteriophage-resistant starter cultures (Sanders 1988). Recombinant DNA techniques also have been used to engineer starter cultures with enhanced bacteriophage resistance (Daly et al. 1996). Recently, the discovery of CRISPR/Cas systems in LAB has led to the speculation that these may be used to enhance bacteriophage resistance in dairy starter cultures (Horvath and Barrangou 2010). These systems (Clustered Regularly Interspaced Short Palindromic Repeats) in combination with *cas* genes (CRISPR-associated), form indigenous adaptive immune systems, which allow acquired immunity to exogenous DNA to which the bacterial cell has had previous exposure.

Flavor Production

LAB produce a range of flavor products such as diacetyl, which has a buttery aroma and is a highly desirable product in many foods (Cogan and Accolas 1996). Strategies involving metabolic engineering, whereby metabolic pathways are manipulated to overproduce specific products, have been used to develop cultures that elaborate elevated levels of diacetyl.

Proteolytic activity of LAB is of major significance in contributing to the liberation of small peptides and amino acids which either add flavor directly or are likely to be flavor precursors.

Commercial Application

Dairy Products

Fermented dairy products are enjoying increased popularity as convenient, nutritious, stable, natural, and healthy foods. LAB are the principal microorganisms involved in the manufacture of cheese, yogurt, sour cream, and cultured butter. In some fermented dairy products, additional bacteria, referred to as secondary microflora, are added to produce carbon dioxide, which influences the flavor and alters the texture of the final product (Early 1998). Two LAB, *Leuconostoc* species and strains of *Lactobacillus lactis* subsp. *lactis*, which are capable of metabolizing citric acid, are added to produce aroma compounds and carbon dioxide in cultured buttermilk and certain cheeses. *Propionibacterium freudenreichii* subsp. *shermanii* is added to Swiss-type cheeses primarily to metabolize L-lactic acid to propionic acid, acetic acid, and carbon dioxide. Carbon dioxide forms the eyes in Swiss-type cheeses. Other types of secondary microflora include undefined mixtures of yeasts, molds, and bacteria (Ray 1996). These microorganisms are added directly to the milk or are smeared, sprayed, or rubbed onto the cheese surface. This group of microorganisms has extremely varied and complex metabolic activities, with their main function being to produce unique flavors. LAB and the predominant microbes used to make fermented dairy products are listed in [Table 8.4](#) (Johnson and Steele 2007).

Cultured Butter and Buttermilk

Cultured butter is made from milk fat to which a mesophilic starter culture has been added to enhance its flavor, principally that of diacetyl. Diacetyl, made from citrate by LAB, enhances buttermilk's storage properties. *Lactobacillus lactis* or mixed cultures that contain *Lb. lactis*, *Leuconostoc citrovorum*, and *Leu. dextranicum* are used (Early 1998). Fat (cream) is separated from skim milk by centrifugation of milk. The cream is pasteurized and inoculated with selected starter cultures. The ripened cream is then churned. The cream separates again into cream butter and its byproduct sour buttermilk, which has limited use because of its high acidity.

An alternative process has been developed to produce cultured butter without the formation of sour buttermilk. In this process, lactose-reduced whey inoculated with *Lactobacillus helveticus* and skim milk inoculated with a starter culture to produce aroma compounds and lactic acid are added to the pasteurized cream. The cream is further churned and worked. The resulting butter is known as sour aromatic butter, and the liquid phase is sweet buttermilk, which is not as acidic as sour buttermilk.

Table 8.4
Microorganisms involved in the manufacture of fermented dairy products

Product	Principal acid producers	Secondary microflora
Cheese		
Colby, Cheddar, cottage, cream	<i>Lactococcus lactis</i> subsp. <i>cremoris</i>	None
	<i>Lactococcus lactis</i> subsp. <i>lactis</i>	
Blue	<i>Lactococcus lactis</i> subsp. <i>cremoris</i>	Cit ⁺ <i>Lactococcus lactis</i> subsp. <i>lactis</i> <i>Penicillium roqueforti</i>
	<i>Lactococcus lactis</i> subsp. <i>lactis</i>	
Mozzarella, provolone, Romano, parmesan	<i>Streptococcus thermophilus</i>	None
	<i>Lactobacillus delbrueckii</i> subsp. <i>bulgaricus</i>	
	<i>Lactobacillus helveticus</i>	
Swiss	<i>Streptococcus thermophilus</i>	<i>Propionibacterium freudenreichii</i> subsp. <i>shermanii</i>
	<i>Lactobacillus delbrueckii</i> subsp. <i>bulgaricus</i>	
	<i>Lactobacillus helveticus</i>	
Fermented milk		
Yogurt	<i>Streptococcus thermophilus</i>	None
	<i>Lactobacillus delbrueckii</i> subsp. <i>bulgaricus</i>	
Buttermilk	<i>Lactococcus lactis</i> subsp. <i>cremoris</i>	<i>Leuconostoc</i> sp. Cit ⁺ <i>Lactococcus lactis</i> subsp. <i>lactis</i>
	<i>Lactococcus lactis</i> subsp. <i>lactis</i>	
Sour cream	<i>Lactococcus lactis</i> subsp. <i>cremoris</i>	None
	<i>Lactococcus lactis</i> subsp. <i>lactis</i>	

Yogurt

Yogurt is produced by fermenting milk, usually cow's milk, with *Streptococcus thermophilus* and *Lactobacillus bulgaricus* (Chandan and Shahani 1993). Initial acid production is largely due to *Str. thermophilus*, but the characteristic yogurt flavor is produced by *Lb. bulgaricus*. Both yogurt cultures

may produce extracellular polymers, which contribute to the viscosity of yogurt. It is desirable that the starter cultures be present in approximately equal numbers to ensure the characteristic flavor, consistency, and odor, otherwise *Lb. bulgaricus* becomes dominant.

Yogurt is generally fermented in batches. Standardized milk, with a fat content of 0.5–3.0 % and milk solids of 14–16 %, is homogenized and pasteurized. After cooling to the incubation temperature, the batch is inoculated with starter cultures and incubated for 16 h at 30 °C or 4 h at 45 °C. The product is then cooled to 2–4 °C and packaged and stored.

Cheese

Cheesemaking is essentially a dehydration process in which milk casein, fat, and minerals are concentrated 6- to 12-fold, depending on the variety. Although the manufacturing protocols for individual varieties differ, the basic steps common to most varieties are acidification, coagulation, dehydration, and salting. Acid production is the major function of the starter bacteria. Lactic acid is responsible for the fresh acidic flavor of unripened cheese and is of importance in coagulation of milk. Coagulation of the casein is accomplished by the concerted action of rennet and by acidification. Starter cultures have other essential roles in the production of volatile flavor compounds (e.g., diacetyl, aldehydes), the synthesis and release of the intracellular proteolytic and lipolytic enzymes involved in the cheese ripening (Steele 1995), and the suppression of pathogens and other spoilage microorganisms (Lewus et al. 1991). For Cheddar cheese production, starter cultures include mixed strains of *Lactobacillus lactis* subsp. *cremoris* or *lactis*. *Leuconostoc* may be added for flavor development. *Streptococcus thermophilus* and *Lb. helveticus* are used in Swiss cheese primarily for acid production, whereas *Propionibacterium* spp. is a secondary culture added for eye formation, taste, and flavor. Similar to Cheddar cheese production, blue cheese production requires *Lb. lactis* subsp. *cremoris* or *lactis* and *Leuconostoc* spp., but the mold *Penicillium roqueforti* is also added as a secondary culture for flavor and blue appearance.

Meat Products

Fermented meat products are defined as meats that are deliberately inoculated during processing to ensure sufficient controlled microbial activity to alter the product's sensory characteristics (Luche 1994). Dry and semidry sausages represent the largest category of fermented meat products, with many present-day processing practices having their origin in the Mediterranean region. Fermented sausages are chopped or ground meat products that, as a result of bacterial activity, reach a pH of 5.3 or less and are then dried. Based on final moisture content, fermented sausages are classified as dry (25–45 % moisture content) or semidry (40–50 % moisture content). To ensure products of consistent flavor, texture, and shelf stability, as well

Table 8.5
Bacteria used as starter cultures in meat and poultry products

Products	Bacteria
Semidry fermented meat sausages	
Lebanon bologna	Mixture of <i>Pediococcus cerevisiae</i> / <i>Lactobacillus plantarum</i>
Summer sausage	<i>P. cerevisiae</i> or mixture/ <i>Lb. plantarum</i>
Cervelat	<i>P. cerevisiae</i> or mixture/ <i>Lb. plantarum</i>
Thuringer	<i>P. cerevisiae</i>
Teewurst	<i>Lactobacillus</i> species
Pork roll	<i>P. cerevisiae</i>
Dry fermented meat sausages	
Pepperoni	<i>P. cerevisiae</i> / <i>Lb. plantarum</i>
Dry sausage	<i>P. cerevisiae</i>
European dry sausage	<i>Micrococcus</i> spp. or <i>Micrococcus</i> / <i>Lactobacillus</i> spp.
Salami	<i>Micrococcus</i> / <i>Lactobacillus</i> spp. or <i>Lb. plantarum</i>
Hard salami, Genoa	<i>Micrococcus</i> spp.
	<i>Micrococcus</i> spp./ <i>P. cerevisiae</i> ; <i>Micrococcus</i> spp./ <i>Lb. plantarum</i>
Fermented poultry sausages	
Semidry turkey sausage	<i>P. cerevisiae</i>
Dry turkey sausage	<i>P. cerevisiae</i> / <i>Lb. plantarum</i>

as to improve product safety, most processors have developed pure microbial cultures to control the fermentation of their sausage product. It is evident that with a starter culture, the pH decreased much more rapidly; hence, the entire manufacturing process is accelerated, leading to economic benefits for the processor. Most starter cultures are natural isolates of the desirable microorganisms present normally in sausage (Egan 1983). A wide variety of species has been used as starter cultures in meat and poultry products (▶ Table 8.5; Ricke et al. 2007).

Vegetable and Fruit Products

The fermentation of vegetables and fruits can be affected by many different microorganisms (Daeschel and Fleming 1984). LAB and yeasts are preferentially used in the western hemisphere, whereas in the Orient, a large number of vegetables are fermented by molds. However, the most extensively used procedure for biopreservation of vegetables involves lactic acid fermentation. Almost all vegetables can be fermented through natural processes because they contain fermentable carbohydrates and harbor many types of LAB. Therefore, many fermented vegetable products are produced by natural fermentation, and some such as cucumbers are now being produced by controlled fermentation (Breidt et al. 2007). Although many

different vegetables are commercially fermented, at present, only olives, cabbage for sauerkraut, and cucumbers for pickles are of major economic importance (Buckenhushkes 1993).

Sauerkraut

Sauerkraut is produced from the natural lactic acid fermentation of cabbage that has been shredded and salted. It is a major fermented vegetable food in Europe and the United States. At the beginning of the fermentation, some oxygen remains in the shredded cabbage. Plant cells, aerobic bacteria, yeasts, and molds consume the remaining oxygen and then die off as the oxygen supply diminishes. The facultative anaerobes then increase in number. Initially, coliform species (e.g., *Enterobacter cloacae*) and *Flavobacterium* species grow to produce gas, volatile fatty acids, and flavors. As the acidity increases, these bacteria are normally replaced by *Leuconostoc mesenteroides*, which become the predominant microbes. They are subsequently succeeded by *Lactobacillus brevis*, *Pediococcus pentosaceus*, and *Lb. plantarum*, which increase the acid level to about 2 % and decrease the pH to 3.4–3.6.

Cucumber Pickles

The starter culture for cucumber fermentation usually consists of the normal mixed microbial flora of cucumbers, including *Lb. mesenteroides*, *Enterococcus faecalis*, *Pediococcus cerevisiae*, *Lb. brevis*, and *Lb. plantarum*. Of these, the pediococci and *Lb. plantarum* are the most involved, with *Lb. brevis* being undesirable because of its ability to produce gas. *Lb. plantarum* is the most essential species in pickle production, as it is for sauerkraut production. The natural fermentation of cucumbers, though in practice for many years, can lead to pickle spoilage and thereby serious economic loss. A controlled fermentation of cucumbers brined in bulk has been developed, and this process not only reduces economic losses but also leads to a more uniform product over a shorter period of time (10–12 days). This method employs a chlorinated brine of 25° salinometer, acidification with acetic acid, the addition of sodium acetate, and inoculation with *P. cerevisiae* and *Lb. plantarum* or with *Lb. plantarum* only.

Olives

Like cucumbers, olives are fruits that are categorized as vegetables and are fermented under conditions similar to those of other vegetable products. The microbial population responsible for the fermentation of olives differs from that of sauerkraut and pickles, mainly because the higher salt concentration of the brine prevents many salt-sensitive strains from growing and provides an advantage to salt-tolerant strains. LAB become prominent during the intermediate stage of fermentation. *Lb. mesenteroides* and *P. cerevisiae* are the first lactics to become predominant, followed by lactobacilli, with *Lb. plantarum* and *Lb. brevis* being

the most important. The fermentation may require as long as 6–10 months to complete, and the final pH of the product is typically 3.8–4.0.

Vinegar

Vinegar (acetic acid) is used as an acidulant and flavor compound in processed foods. It is produced by an alcoholic fermentation of sugar-containing plant extracts followed by a microbial oxidation of ethanol to acetic acid (Sievers and Teuber 1995). The slow process of natural acetification of wines and ciders is the oldest method of making vinegar. The Orleans process, developed in France for the industrial production of vinegar at the end of the fourteenth century, is also a slow fermentation in which the substrate “wine” is placed in barrels and inoculated with fresh vinegar or with the slimy, thick microbial film formed on the surface of the fermenting mash during acetification. Technological advances have led to a submerged culture process in which a suspension of *Acetobacter* spp. grows in an ethanol-containing substrate with constant agitation and small air bubbles. Commercial strains of *Acetobacter* include low cost, higher yields, less space required, and low evaporation loss.

Malolactic Fermentation in Wine

Malolactic fermentation (carried out by many LAB) involves the decarboxylation of malic acid to lactic acid and CO₂. In winemaking as well as in production of cider and perry, LAB reduce acidity by converting malic to lactic acid and modify flavor and texture, which in part mature a beverage (Henick-Kling 1995). Red and white wines are commonly produced by a yeast alcoholic fermentation of musts prepared from grapes. After alcoholic fermentation, wines frequently undergo malolactic fermentation. This process occurs naturally at or near the completion of alcoholic fermentation. Wines produced from grapes cultivated in cool climates generally have higher concentrations of malic acid, which can mask the varietal character of the wine. Decreasing acidity by malolactic fermentation produces a wine with a softer and mellower taste. LAB resident in wine are responsible for the malolactic fermentation. However, since the early 1980s, commercial starter cultures consisting of *Leuconostoc oenos*, *Lb. plantarum*, and *Lb. hilgardii* as single- or multiple-strain preparations have been available for the induction of malolactic fermentation (Buckenhuskus 1993). The malolactic fermentation is more commonly used in red wines, although recently, it is increasingly used in white wines.

Indigenous Fermented Beverages

Production of indigenous fermented beverages (examples listed in Table 8.6) often involves complex biochemical, sensory, and nutritional changes that can result from more or less controlled microbial activity in a range of raw materials (Beuchat 1997).

The preparation of many indigenous or traditional fermented beverages is a household art. Hence, they are often produced regionally or by different ethnic groups and are not commercially available (Steinkraus 1983). The microbiology of indigenous fermented beverages is less clear. In many cases, LAB and yeasts both contribute to the fermentation process.

Probiotic Bacteria and Competitive Exclusion

The 2002 definition of a probiotic by a joint FAO/WHO working group is likely the most widely accepted: “Live microorganisms which when administered in adequate amounts confer a health benefit to the host” (Anonymous 2002). This definition indicates that probiotics need to be viable in the gastrointestinal tract. Although viability indicates that cells are living, there are many states of viability, and in the case of probiotics, viability is generally taken to mean culturability (Ouweland et al. 2011). Other criteria for probiotics include human origin, safety for human use, scientific validation of health effects, stability to acid and bile, ability to adhere to intestinal mucosa, accurate taxonomic identification and characterization, and good technological properties (Ouweland et al. 2011). Although several types of microorganisms have been utilized for their probiotic effects, such as *Bifidobacterium*, *Bacillus*, and yeast species, the most commonly utilized are LAB. LAB have been used in foods for centuries, and most strains are considered commensal microorganisms with no pathogenic potential. Their omnipresence on the intestinal epithelium of the human gastrointestinal tract, their traditional use in fermented foods without significant health-associated problems, and their health-promoting benefits make this group of bacteria ideal candidates for use as a probiotic (Naidu et al. 1999).

Probiotic Bacteria in Food

The practice of incorporating probiotic bacteria into food is as old as fermented foods themselves, and traditional cultured products such as yogurt and kefir have beneficial health effects. However, the practice of delivering probiotic strains in food products for their specific health effects has seen increasing interest as more strains are identified and validated through clinical trials. The variety of foods utilized for probiotic incorporation is also increasing as technologies for improved delivery of high numbers of viable cells to the gastrointestinal tract improves. Probiotics have been typically delivered in foods such as fermented milk products and pharmaceutical products such as tablets or capsules, but the number of foods used as delivery vehicles for probiotic strains is growing, and these have been reviewed recently (Saarela 2011) and include foods such as fruit and vegetable juices, cereal-based products, sausages, and even ice cream. Many health effects of probiotic bacteria have been documented, and beneficial effects include protection against enteric pathogens (Jeppesen and Huss 1993; Lewus et al. 1991; Okereke and Montville 1991; Rodriguez et al. 1997),

Table 8.6

Examples of indigenous fermented beverages

Product	Geography	Substrate	Microorganism(s)	Product use
Busa	Tartars of Krim, Turkestan, Egypt	Rice or millet, sugar	<i>Lactobacillus</i> and <i>Saccharomyces</i> spp.	Drink
Mahewu (Magou)	South Africa	Maize	LAB	Sour and nonalcoholic drink
Pito	Nigeria	Guinea corn or maize or both	Yeast, LAB	Drink
Sorghum beer	South Africa	Sorghum, maize	LAB, yeast	Acidic and weakly alcoholic drink
Soybean milk yogurt	China, Japan	Soybeans	LAB	Drink
Pulque	Mexico	Agave	LAB, <i>Saccharomyces</i> spp., <i>Zymomonas mobilis</i>	Alcoholic drink

LAB lactic acid bacteria

detoxification and improved digestion by means of enzymes to metabolize some food nutrients (e.g., lactase to hydrolyze lactose; Gilliland 1990) and removal of some harmful food components and metabolites (El-Nezami and Ahokas 1998), stimulation of the intestinal immune system (Salminen and Deighton 1992; Salminen and Salminen 1997), and improvement of intestinal peristaltic activity (Rafter 1995). Recent findings in the progress of research in probiotic health effects are reviewed by Yan and Polk (2010).

Competitive Exclusion Concept

The competitive exclusion concept was originated by Nurmi and Rantala (1973), based on the study of *Salmonella* in chickens. Newly hatched birds in modern hatcheries are not able to obtain the normal gut flora of adult birds. As a result, the intestines of chicks can be easily colonized by foodborne pathogens when present. When the chickens were inoculated immediately after birth with the intestinal content of a *Salmonella*-free adult bird, the frequency of *Salmonella* infections was radically reduced and the number of *Salmonella* needed to colonize the ceca of chicks increased. Hence, the normal gastrointestinal microflora of adult chickens can competitively exclude *Salmonella* from colonizing the naïve intestinal tract of chicks.

Competitive Exclusion of Foodborne Pathogens

After establishment of the basic concept of competitive exclusion, considerable research has been done to identify the mechanisms by which bacteria are competitively excluded from host sites (Nurmi et al. 1992; Zhao et al. 1995). Responsible factors include competition for receptor sites on the intestinal epithelium, production of volatile fatty acids and/or other antibacterial substances, and competition among different bacteria for limited nutrients. The use of LAB as a probiotic for live poultry and livestock has been extensively studied and has

potential to reduce carriage of pathogens and increase growth rates (Abe et al. 1995; Hammes and Tichaczek 1994). Cecum-colonizing bacteria including *Escherichia coli* that produce inhibitory metabolites to *Campylobacter jejuni* have been used successfully to reduce intestinal carriage of *C. jejuni* by poultry (Aho et al. 1992; Schoeni and Doyle 1992). Similarly, *E. coli* strains that produce antimicrobial metabolites to *E. coli* O157:H7 have been confirmed effective in reducing carriage of *E. coli* O157:H7 by cattle (Zhao et al. 1998).

Prospects

For many years, bacteria, mainly LAB, have been involved in the fermentation of foods from raw agricultural materials such as milk, meat, vegetables, fruits, and cereals. Fermented foods are a significant part of the food processing industry and are often produced using bacteria that have been selected for their ability to effectively produce desired products or changes. The interaction of LAB and other bacteria in enhancing the physiology, nutrition, and metabolism of humans and animals and their involvement in promoting health and reducing disease are additional roles that prokaryotes can serve by their presence in foods. Over the past decade, there have been major developments in furthering our understanding of both the biochemistry and physiology of bacteria involved in food fermentations. Advanced molecular techniques have served as invaluable tools for the development of defined mutants that have enabled basic studies on proteolysis, peptidase action, and peptide transport. Knowledge from such studies is invaluable for the design and modification of commercially useful strains. The application of genetic engineering technology to improve existing strains through enhanced bacteriophage resistance or more efficient metabolic characteristics such as proteolytic activities or to develop novel strains for fermentations has greatly contributed to the success of the fermentation industry through more consistent production of high quality, uniform products and less fermentation failure. Finally, the use of LAB to enhance quality and safety of

food is a quickly evolving field. As new LAB bacteriocins and other antimicrobial metabolites are discovered and more efficient ways are developed to deliver them to food in the form of protective cultures or fermentates, the importance of LAB in food protection intervention strategies will continue to expand.

References

- Abe F, Ishibashi N, Shimamura (1995) Effect of administration of bifidobacteria and lactic acid bacteria to newborn calves and piglet. *J Dairy Sci* 78:2838–2846
- Aho M, Nuotio L, Nurmi E, Kiiskinen T (1992) Competitive exclusion of campylobacters from poultry with K-bacteria and Broilact. *Int J Food Microbiol* 15:265–275
- Anonymous (2002) Guidelines for the evaluation of probiotics in food. Joint FAO/WHO working group report on drafting guidelines for the evaluation of probiotics in food. http://www.who.int/foodsafety/publications/fs_management/probiotics2/en/
- Axelsson L (1998) Lactic acid bacteria: classification and physiology. In: Salminen S, von Wright A (eds) *Lactic acid bacteria—microbiology and functional aspects*. Marcel Dekker, New York, pp 1–72
- Beuchat LR (1997) Traditional fermented foods. In: Doyle M, Beuchat L, Montville T (eds) *Food microbiology—fundamentals and frontiers*. ASM Press, Washington, DC, pp 629–648
- Breidt F Jr, McFeeters RF, Díaz-Muñoz I (2007) Fermented vegetables. In: Doyle M, Beuchat L (eds) *Food microbiology—fundamentals and frontiers*, 3rd edn. ASM Press, Washington, DC, pp 783–794
- Breukink E, de Kruiff B (2006) Lipid II as a target for antibiotics. *Nat Rev Drug Discov* 5:321–333
- Buckenhuskes H (1993) Selection criteria for lactic acid bacteria to be used as starter cultures for various food commodities. *FEMS Microbiol Rev* 12:253–272
- Chandan R, Shahani K (1993) *Yoghurt*. In: Hui Y (ed) *Dairy science technology handbook*. VCH, New York, pp 2–53
- Chebbi NB, Chander H, Ranganathan B (1977) Casein degradation and amino acid liberation in milk by two highly proteolytic strains of lactic acid bacteria. *Acta Microbiol Pol* 26:281–284
- Cogan T, Accolas J (1996) *Dairy starter cultures*. VCH, New York
- Collins-Thompson DL, Slade PJ, Goethals M (1991) Use of low molecular mass RNA profiles to identify lactic acid bacteria and related organisms associated with foods. *Int J Food Microbiol* 14:135–143
- Cotter PD, Hill C, Ross RP (2005) Bacteriocins: developing innate immunity for food. *Nat Rev Microbiol* 3:777–788
- Daeschel M, Fleming H (1984) Selection of lactic acid bacteria for use in vegetable fermentations. *Food Microbiol* 1:303–313
- Daly C, Fitzgerald GF, Davis R (1996) Biotechnology of lactic acid bacteria with special reference to bacteriophage resistance. *Antonie Van Leeuwenhoek* 70:99–110
- De Ambrosini VM, Gonzalez S, Perdigon G, de Ruiz Holgado AP, Oliver G (1996) Chemical composition of the cell wall of lactic acid bacteria and related species. *Chem Pharm Bull (Tokyo)* 44:2263–2267
- De Vos WM (1999) Gene expression systems for lactic acid bacteria. *Curr Opin Microbiol* 2:289–295
- Deegan LH, Cotter PD, Hill C, Ross P (2006) Bacteriocins: biological tools for bio-preservation and shelf-life extension. *Int Dairy J* 16:1058–1071
- Delves-Broughton J, Blackburn P, Evans RJ, Hugenholtz J (1996) Applications of the bacteriocin, nisin. *Antonie Van Leeuwenhoek* 69:193–202
- Dinsmore PK, Klaenhammer TR (1995) Bacteriophage resistance in *Lactococcus*. *Mol Biotechnol* 4:297–314
- Early R (1998) In: Early R (ed) *The technology of dairy products*, 2nd edn. Blackie, London
- Egan AF (1983) Lactic acid bacteria of meat and meat products. *Antonie Van Leeuwenhoek* 49:327–336
- El-Nezami H, Ahokas J (1998) Lactic acid bacteria: an approach for detoxification of aflatoxins. In: Salminen S, von Wright A (eds) *Lactic acid bacteria—microbiology and functional aspects*. Marcel Dekker, New York, pp 359–368
- Galvez A, Abriouel H, Lopez RL, Omar NB (2007) Bacteriocin-based strategies for food biopreservation. *Int J Food Microbiol* 120:51–70
- Gasson MJ (1990) In vivo genetic systems in lactic acid bacteria. *FEMS Microbiol Rev* 7:43–60
- Geisen R, Holzapfel WH (1996) Genetically modified starter and protective cultures. *Int J Food Microbiol* 30:315–324
- Gilarova R, Voldrich M, Demnerova K, Cerovsky M, Dobias J (1994) Cellular fatty acids analysis in the identification of lactic acid bacteria. *Int J Food Microbiol* 24:315–319
- Gilliland SE (1990) Health and nutritional benefits from lactic acid bacteria. *FEMS Microbiol Rev* 7:175–188.
- Hammes WP, Tichaczek PS (1994) The potential of lactic acid bacteria for the production of safe and wholesome food. *Z Lebensm Unters Forsch* 198:193–201
- Heng NCK, Tagg JR (2006) What's in a name? Class distinction for bacteriocins. *Nat Rev Microbiol* 4(2). doi:10.1038/nrmicro1273-c1
- Henick-Kling T (1995) Control of malo-lactic fermentation in wine: energetics, flavour modification and methods of starter culture preparation. *J Appl Bacteriol* 79(Suppl):29S–37S
- Horvath P, Barrangou R (2010) CRISPR/Cas, the immune system of bacteria and archaea. *Science* 327:167–170
- Jay J, Loessner MJ, Golden DA (2007) *Modern food microbiology*, 7th edn. Chapman & Hall, New York, 790 pp
- Jeppesen VE, Huss HH (1993) Antagonistic activity of two strains of lactic acid bacteria against *Listeria monocytogenes* and *Yersinia enterocolitica* in a model fish product at 5 degrees C. *Int J Food Microbiol* 19:179–186
- Johnson M, Steele J (2007) Fermented dairy products. In: Doyle M, Beuchat L (eds) *Food microbiology—fundamentals and frontiers*, 3rd edn. ASM Press, Washington, DC, pp 767–782
- Jones RJ, Wescombe PA, Tagg JR (2011) Identifying new protective cultures and culture components for food biopreservation. In: Lacroix C (ed) *Protective cultures, antimicrobial metabolites and bacteriophages for food and beverage biopreservation*. Woodhead, Cambridge, UK, pp 3–26
- Kandler O (1983) Carbohydrate metabolism in lactic acid bacteria. *Antonie Van Leeuwenhoek* 49:209–224
- Klaenhammer TR (1991) Development of bacteriophage-resistant strains of lactic acid bacteria. *Biochem Soc Trans* 19:675–681
- Klaenhammer TR (1993) Genetics of bacteriocins produced by lactic acid bacteria. *FEMS Microbiol Rev* 12:39–86
- Klein G, Pack A, Bonaparte C, Reuter G (1998) Taxonomy and physiology of probiotic lactic acid bacteria. *Int J Food Microbiol* 41:103–125
- Kuipers OP, de Ruyter PG, Kleerebezem M, de Vos WM (1997) Controlled overproduction of proteins by lactic acid bacteria. *Trends Biotechnol* 15:135–140
- Lee B (1996) Bacteria-based processes and products. In: Lee B (ed) *Fundamentals of food biotechnology*. VEH, New York, pp 219–290
- Lee JH, Li X, O'Sullivan DJ (2011) Transcription analysis of a lantibiotic gene cluster from *Bifidobacterium longum* DJO10A. *Appl Environ Microbiol* 77:5879–5887
- Leroy F, De Vuyst L (2010) Bacteriocins of lactic acid bacteria to combat undesirable bacteria in dairy products. *Aust J Dairy Technol* 65:143–149
- Lewus CB, Kaiser A, Montville TJ (1991) Inhibition of food-borne bacterial pathogens by bacteriocins from lactic acid bacteria isolated from meat. *Appl Environ Microbiol* 57:1683–1688
- Luche F (1994) Fermented meat products. *Food Res Int* 27:299–308
- Makela P, Schillinger U, Korkeala H, Holzapfel WH (1992) Classification of ropy slime-producing lactic acid bacteria based on DNA-DNA homology, and identification of *Lactobacillus sake* and *Leuconostoc amelibiosum* as dominant spoilage organisms in meat products. *Int J Food Microbiol* 16:167–172
- Mayo B (1993) The proteolytic system of lactic acid bacteria. *Microbiologia* 9:90–106
- McKay LL, Baldwin KA (1990) Applications for biotechnology: present and future improvements in lactic acid bacteria. *FEMS Microbiol Rev* 7:3–14

- Morelli L, Vogensen FK, von Wright A (2004) Genetics of lactic acid bacteria. In: Salminen S, von Wright A, Ouwehand A (eds) Lactic Acid Bacteria: microbiological and functional aspects. Marcel Dekker, New York, pp 249–293
- Naidu AS, Bidlack WR, Clemens RA (1999) Probiotic spectra of lactic acid bacteria (LAB). *Crit Rev Food Sci Nutr* 39:13–126
- Nurmi E, Rantala M (1973) New aspects of *Salmonella* infection in broiler production. *Nature* 241:210–211
- Nurmi E, Nuotio L, Schneitz C (1992) The competitive exclusion concept: development and future. *Int J Food Microbiol* 15:237–240
- Okereke A, Montville TJ (1991) Bacteriocin-mediated inhibition of *Clostridium botulinum* spores by lactic acid bacteria at refrigeration and abuse temperatures. *Appl Environ Microbiol* 57:3423–3428
- Ouwehand AC, Sondberg Svendsen L, Leyer G (2011) Probiotics: from strain to product. In: Kniebel W, Salminen S (eds) Probiotics and health claims. Wiley, W. Sussex, pp 37–47
- Poolman B, Kunji E, Hagting A, Juillard V, Konings W (1995) The proteolytic pathway of *Lactococcus lactis*. *J Appl Bacteriol* 79:65S–75S
- Pritchard GG, Coolbear T (1993) The physiology and biochemistry of the proteolytic system in lactic acid bacteria. *FEMS Microbiol Rev* 12:179–206
- Rafter JJ (1995) The role of lactic acid bacteria in colon cancer prevention. *Scand J Gastroenterol* 30:497–502
- Ray B (1996) Fundamental food microbiology. CRC Press, Boca Raton
- Ricke S, Zabala Diaz I, Keeton JT (2007) Fermented meat, poultry, and fish products. In: Doyle M, Beuchat L (eds) Food microbiology—fundamentals and frontiers, 3rd edn. ASM Press, Washington, DC, pp 795–816
- Rodriguez A, Vidal DR (1990) Genetics of lactic acid bacteria with special reference to *lactococci*. *Microbiologia* 6:51–64
- Rodriguez E, Tomillo J, Nunez M, Medina M (1997) Combined effect of bacteriocin-producing lactic acid bacteria and lactoperoxidase system activation on *Listeria monocytogenes* in refrigerated raw milk. *J Appl Microbiol* 83:389–395
- Saarela MH (2011) Probiotic functional foods. In: Saarela M (ed) Functional foods: concept to product. Woodhead, Cambridge, UK, pp 425–488
- Salminen S, Deighton M (1992) Lactic acid bacteria in the gut in normal and disordered states. *Dig Dis* 10:227–238
- Salminen S, Salminen E (1997) Lactulose, lactic acid bacteria, intestinal microecology and mucosal protection. *Scand J Gastroenterol Suppl* 222:45–48
- Sanders ME (1988) Phage resistance in lactic acid bacteria. *Biochimie* 70:411–422
- Schoeni JL, Doyle MP (1992) Reduction of *Campylobacter jejuni* colonization of chicks by cecum-colonizing bacteria producing anti-*C. jejuni* metabolites. *Appl Environ Microbiol* 58:664–670
- Sievers M, Teuber M (1995) The microbiology and taxonomy of *Acetobacter europaeus* in commercial vinegar production. *J Appl Bacteriol (Suppl)* 79:85S–95S
- Stackebrandt E, Teuber M (1988) Molecular taxonomy and phylogenetic position of lactic acid bacteria. *Biochimie* 70:317–324
- Steele JL (1995) Contribution of lactic acid bacteria to cheese ripening. *Adv Exp Med Biol* 367:209–220
- Steinkraus KH (1983) Handbook of indigenous fermented foods. Marcel Dekker, New York
- Stiles ME, Holzapfel WH (1997) Lactic acid bacteria of foods and their current taxonomy. *Int J Food Microbiol* 36:1–29
- Svetoch EA, Stern NJ (2010) Bacteriocins to control *Campylobacter* spp. in poultry – a review. *Poult Sci* 89:1763–1768
- Thompson J (1988) Lactic acid bacteria: model systems for in vivo studies of sugar transport and metabolism in gram-positive organisms. *Biochimie* 70:325–336
- Vandamme P, Pot B, Gillis M, de Vos P, Kersters K, Swings J (1996) Polyphasic taxonomy, a consensus approach to bacterial systematics. *Microbiol Rev* 60:407–438
- Verris CT, van den Berg DJ (1996) Barriers to application of genetically modified lactic acid bacteria. *Antonie Van Leeuwenhoek* 70:299–316
- Weber G, Steenson L, Delves-Broughton J (2008) Antimicrobial fermentate technology. In: Havkin-Frenkel D, Dudai N, van der Mheen H (eds) II International symposium on natural preservatives in food, feed, and cosmetics, vol 778, Acta Hort. International Society for Horticultural Science, Belgium, pp 79–84
- Whitehead HR, Cox GA (1935) The occurrence of bacteriophage in cultures of lactic streptococci. *N Z J Sci Technol* 16:319–320
- Wiedemann I, Breukink E, van Kraaij C, Kuipers OP, Bierbaum G, de Kruijff B, Sahl HG (2001) Specific binding of nisin to the peptidoglycan precursor lipid II combines pore formation and inhibition of cell wall biosynthesis for potent antibiotic activity. *J Biol Chem* 276:1772–1779
- Yan F, Polk DB (2010) Probiotics: progress toward novel therapies for intestinal diseases. *Curr Opin Gastroenterol* 26:95–101
- Zhao S, Meng J, Zhao T, Doyle M (1995) Use of vaccine and biological control techniques to control pathogens in animals used for food. *J Food Safety* 15:193–199
- Zhao T, Doyle MP, Harmon BG, Brown CA, Mueller PO, Parks AH (1998) Reduction of carriage of enterohemorrhagic *Escherichia coli* O157:H7 in cattle by inoculation with probiotic bacteria. *J Clin Microbiol* 36:641–647

9 Bacterial Pharmaceutical Products

Giancarlo Lancini¹ · Arnold L. Demain²

¹Fondazione Istituto Insubrico Ricerca per la Vita (FIIRV), Milan, Italy

²Research Institute for Scientists Emeriti, Drew University, Madison, NJ, USA

Introduction	258
Secondary Metabolites	258
Antibiotics	258
Families of Classical Antibiotics	259
Nonclassical Antibiotics	262
Search for New Antibiotics in the Following Decades	264
Antitumor Agents	265
Other Bioactive Metabolites	265
Immunosuppressive Agents	266
Enzyme Inhibitors	266
Insecticides and Antiparasitic Agents	267
Biochemical and Genetic Aspects of Secondary Metabolism	268
Regulation of Secondary Metabolite Production	268
Secondary Metabolite Biosynthetic Pathways	269
The Three Classes of Biosynthetic Reactions	270
Products from Modern Technology	272
Production of Recombinant Proteins	272
Hosts for Recombinant Protein Production	273
<i>Escherichia coli</i>	273
<i>Saccharomyces cerevisiae</i>	273
Mammalian Cell Lines	273
Genetic Engineering of Secondary Metabolism	274
Protoplast Fusion	274
Use of Genetic Engineering to Improve Productivity or to Produce Modified Antibiotics	274
Combinatorial Biosynthesis	275
Combinatorial Biosynthesis of Polypeptide Antibiotics	276
Closing Remarks	276

Abstract

Bacterial pharmaceutical products include antibiotics, antitumor agents, immunomodulators, and enzyme inhibitors. Other bioactive products of bacterial origin are coccidiostatic agents, nematocides, and insecticides. In addition, *Escherichia coli*, the prototype of molecular biology, is one of the most important hosts for the production of pharmaceutical recombinant proteins.

The approach to antibiotic discovery, denoted as “screening,” proposed by Waksman in 1940, was so effective that by the end of the 1950s, members of all the main families of clinically useful antibiotics were discovered. In the following years, the screening concepts were refined, introducing methods to select organisms which were potential producers of novel antibiotics and orienting the screening toward biochemical targets rather than general activities. The approach was successful, and many interesting products were identified in the period of 1960–1980. In the following decades, the research was mainly driven by the need to stop the spread of antibiotic multiresistant strains due to the horizontal transmission of resistance genes. Some important success has been obtained, mainly by target-oriented modification of members of classical families of antibiotics.

Most of the clinically effective antitumor agents were discovered in the 1960s by testing against tumor cell lines the active metabolites which were too toxic for use as anti-infective drugs. Only recently, a new family of products, active by stabilizing microtubulins, has been discovered by a target-oriented screening.

Among the other bioactive metabolites, two products of *Streptomyces* have important clinical use as immunomodulators, and members of the avermectin family are largely used against nematode and arthropod infections. A family of exceptionally effective insecticides, the spinosins, receives an increasing share of the agricultural market.

Most of the bacteria producing therapeutically effective antibiotics are actinomycetes, organisms belonging to the order Actinomycetales. Most of the products are produced by member of the genus *Streptomyces*. The genetics and biochemistry of antibiotic production has been mainly studied in strains of this genus. Antibiotics are products of the secondary metabolism, a form of cellular chemical differentiation linked in time, and sharing some initiator genes with cell morphological differentiation. The biosynthetic pathways yielding the backbone of most molecules of actinomycete pharmaceutical products consist of five different polymerization mechanisms: (1) and (2) the iterative polyketide synthases and modular polyketide synthases formed from small carboxylic acids units, polyaromatic compounds, and aliphatic chains; (3) the thiotemplate mechanism of polypeptide synthesis, by which most of the peptide antibiotics are produced; (4) the ribosome-dependent amino acid polymerization, which synthesizes the peptide antibiotics; and (5) the condensation of carbohydrate units forming the aminosaccharide antibiotics.

The genes governing the production of secondary metabolites are grouped in clusters, composed of structural genes encoding the enzymes catalyzing the synthesis of the molecule, and regulatory genes, determining the activation of the

structural genes. During the growth phase of the *Streptomyces* life cycle, all the genes of the cluster are repressed. When the deprivation of an essential nutrient induces the onset of cell differentiation, a cascade of events activates the transcription of the regulatory genes, which in turn activate the genes governing the biosynthesis. Genetic studies have been essential in understanding the mechanisms of antibiotic synthesis regulation. Most relevant successes have been recently obtained by genetic engineering for the improvement of metabolite production, especially in orienting the production toward the preferred members of the metabolite complexes.

Introduction

In contrast to plant metabolites, whose use against diseases has roots in folk and traditional medicine, bacterial pharmaceutical products are the result of large targeted research efforts, carried out by tens of laboratories all around the world. The original approach (later denoted “screening”) of Selman Waksman in 1939–1940 (Waksman and Woodruff 1940) consisted of (1) systematically collecting soil microorganisms, (2) growing them in axenic culture, (3) testing the culture broths for their ability to inhibit the growth of pathogens, and (4) recovering the active substances produced. It was rapidly found that actinomycetes were most frequently positive; in particular, nearly 50 % of *Streptomyces* strains isolated were active, mainly against Gram-positive bacteria. This widely applied approach was very fruitful by the early 1960s, and members of all the main families of clinically useful antibiotics were discovered. With the exception of the penicillins, cephalosporins and a few minor products, all were produced by actinomycetes. Their collective spectra of action covered practically all the important bacterial pathogens.

In the 1960s, the need was felt for a substantial revision of the objectives and the methods of the screening. The number of antibiotics isolated was such that repetitions of discovery became more and more frequent. In fact, 1,300 metabolites had been reported in journals or patents by 1960, and over 2,000 by 1965 (data from Biosearch Italia database, courtesy of G. Toppo). General antibacterial activity appeared to be a less attractive target than activity against fungi, viruses, or antibiotic-resistant bacterial strains. Antitumor efficacy was also considered as a possible target. Therefore, the search for novel metabolites was slowly changed in the various laboratories. Some devised methods for mass screening of unusual genera of microorganisms (such as rare actinomycetes) or organisms living in different (e.g., marine) environments. Others relied upon the use of new targets, rather than on isolation of novel producers, to select new products. The result was the discovery of novel and important antimicrobial agents, antitumor substances, and inhibitors of mammalian enzymes of potential pharmaceutical interest. Mammalian enzymes have been especially targeted in recent years, with the isolation of pharmacologically active metabolites and of antimicrobial agents occurring at present at about the same frequency. However, the number of new products of proven clinical value has been unfortunately declining.

All these natural products are known as secondary metabolites (“idiolites”). They are low molecular weight products of microbial metabolism (such as antibiotics, pheromones, sex hormones, etc.) that differ from primary metabolites (amino acids, vitamins, purines, pyrimidines, etc.) in that they are not involved in growth processes but rather in mechanisms of survival in nature.

The advent of modern biotechnology opened totally new perspectives for the use of microorganisms as producers of pharmaceutical products. Genetic engineering provided methods (such as altering biosynthetic genes or inserting selected genes into the DNA of an antibiotic-producing strain) for obtaining modified secondary metabolites. Moreover, a number of new metabolites could be obtained by randomly combining the genes of two or more gene clusters governing similar biosynthetic pathways. Even more important, the progress of biotechnology made feasible the industrial production of mammalian proteins and peptides by bacteria and other hosts. The stages of this development have been the following (1) biosynthesis of known clinically useful proteins (e.g., insulin and human growth hormone) and the generation of monoclonal antibodies to them, (2) identification and cloning of genes encoding physiologically important, lesser-known proteins (e.g., interferons, interleukins, colony stimulation factors, cytokines, thrombolytic agents, and vaccines), and finally, (3) provision of macromolecules (e.g., receptors, ligands, enzymes, cytoskeleton proteins, adhesion molecules, signaling proteins, and regulatory elements) to be used in screening for modulators. We summarize in this chapter the main results obtained during the past 70 years in the search and development of the various classes of medically useful substances produced by bacteria.

Secondary Metabolites

Bacterial secondary metabolites are relatively small molecules, each produced by a limited number of strains that appear to have no obvious function in growth. In fact, producer strains that by mutation have lost their production ability exhibit perfectly normal growth rates and characteristics. Secondary metabolites include antibiotics, pigments, toxins, effectors of ecological competition and symbiosis, pheromones, enzyme inhibitors, immunomodulating agents, receptor antagonists and agonists, pesticides, antitumor agents, and growth promotants of animals and plants. Nature produces an amazing variety and number of such products. At the end of 1999, over 23,400 microbial secondary metabolites were known. Of these, 42.1 % were produced by fungi, 42.4 % by actinomycetes, and 15.5 % by other bacteria (Lazzarini et al. 2001). New bioactive products from microbes continued to be discovered at an amazing pace: 200–300 per year in the late 1970s increasing to 500 per year by 1997.

Antibiotics

The most important microbial metabolites so far isolated are antibiotics, i.e., substances (produced by microorganisms) that inhibit at low concentrations the growth of different species

of microorganisms. They exert a major effect on the health, nutrition, and economics of our society. An analysis by Berdy revealed that by 2002, 16,500 antibiotics and 6,000 metabolites with other biological activities were known. Of these, 8,700 antibiotics and 1,400 other bioactive metabolites were produced by actinomycetes, and 2,900 antibiotics and 900 other bioactive metabolites were produced by bacteria (Berdy 2005). In addition to their number, another impressive aspect of antibiotics is the variety of their chemical structures. Many different classes of organic chemistry are represented: aliphatic chains, aromatic rings isolated or condensed, heterocyclic rings (all substituted with any imaginable function) and oligopeptides, oligosaccharides, and so on.

The property that makes antibiotics “wonder drugs” is the selectivity of their mechanisms of antimicrobial action, which distinguishes them from the plethora of synthetic disinfectants and germicides. We have benefited for 70 years from their remarkable property of being selectively toxic to some class of organisms. The successes were so impressive that antibiotics were, with a few exceptions, the only drugs utilized for therapy against most pathogenic microorganisms. By 1996, the world market for antimicrobials amounted to \$23 billion and involved some 150–300 products (natural, semisynthetic, or synthetic), which included cephalosporins (45 %), penicillins (15 %), quinolones (11 %), tetracyclines (6 %), macrolides (5 %), thienamycin, and others (Strohl 1997).

Families of Classical Antibiotics

Antibiotics are commonly grouped into families. A family is comprised of all the products having a similar chemical structure and sharing the same mechanism of antimicrobial action. We summarize here the characteristics of the classical antibiotic families used in human therapy (Lancini et al. 1995).

β -Lactams. Typical of the chemical structure of these antibiotics is the presence of a four-membered ring closed by an amide bond. They exert a killing action on many bacterial species by inhibiting the assembly of the peptidoglycan component of the cell wall. Fungi produce the classical subfamilies, penicillins and cephalosporins, although bacteria make modified cephalosporins, e.g., cephamycins. Thienamycin, one of the last commercial antibiotics discovered and which possesses a β -lactam ring and an exceptionally broad spectrum of action, is produced by a prokaryote, *Streptomyces cattleya* (► Fig. 9.1).

Aminoglycosides. Chemically, these are oligosaccharides comprising aminosugars and an aminocyclitol moiety, i.e., an alicyclic six-membered ring with hydroxyl and amino substituents. They are mainly active on Gram-negative bacteria and act by irreversibly inhibiting protein synthesis. The main products are streptomycin from *Streptomyces griseus*, and gentamicins, produced by *Micromonospora purpurea* (► Fig. 9.2).

Tetracyclines. Characteristically composed of four six-membered rings linearly arranged, these broad-spectrum antibiotics act by inhibiting protein synthesis at the ribosomal level,

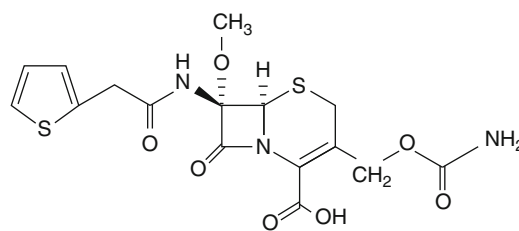

Cefoxitin (a semisynthetic cephamycin)

Fig. 9.1

Cefoxitin (a semisynthetic cephamycin)

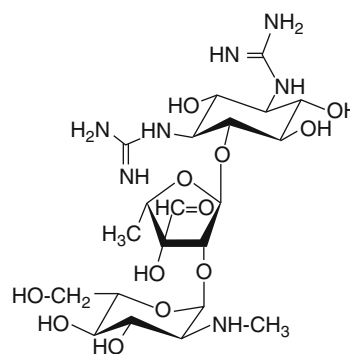

Streptomycin

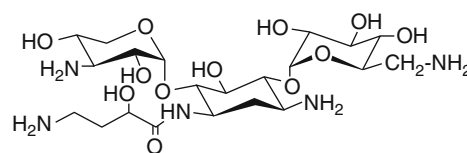

Amikacin (a semisynthetic aminoglycoside)

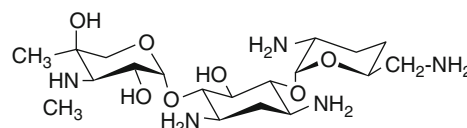

Gentamicin C1a

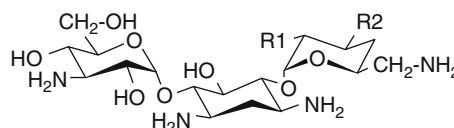

R1	R2	Name
OH	OH	kanamycin A
NH ₂	OH	kanamycin B
NH ₂	H	Tobramycin

Fig. 9.2

Aminoglycosides

but their binding site on the 30S ribosomal subunit differs from that of aminoglycosides. In clinical use are oxytetracycline produced by *Streptomyces rimosus*, tetracycline and chlortetracycline from *Streptomyces aureofaciens*, and a number of their derivatives (● Fig. 9.3).

Antibacterial Macrolides. This is a large family of products characterized by a lactone ring of 12–16 atoms bearing two or more sugar substituents. The best-known representative is erythromycin, produced by *Saccharopolyspora erythraea*. It

inhibits protein synthesis, binding (unlike tetracyclines) to the 50S ribosomal subunit (● Fig. 9.4).

Polyenes. These antifungal macrolides differ from antibacterial macrolides in the size of the lactone ring, ranging from 26 to 38 atoms, and with the presence of a series of conjugated double bonds. The only member systemically used is amphotericin B, produced by *Streptomyces nodosus*. Antifungal activity is due to interference with membrane sterols, resulting in permeability alteration (● Fig. 9.5).

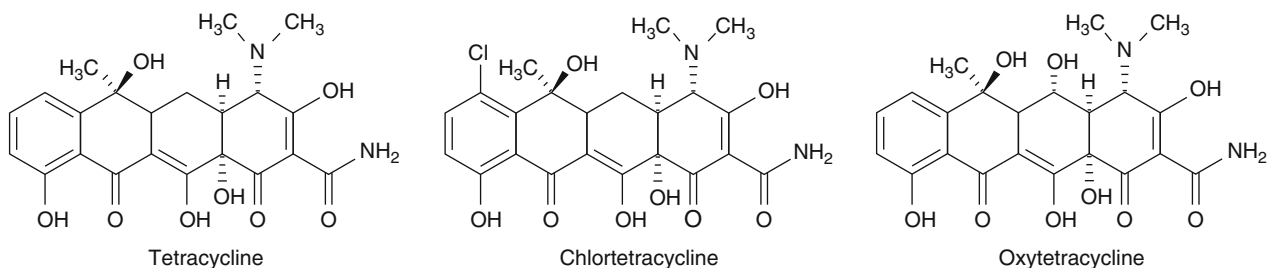

■ Fig. 9.3
Tetracyclines

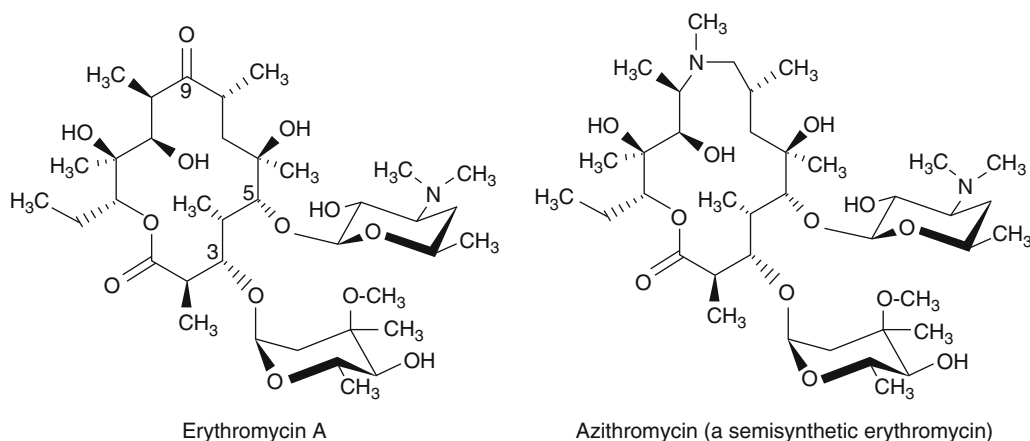

■ Fig. 9.4
Macrolides

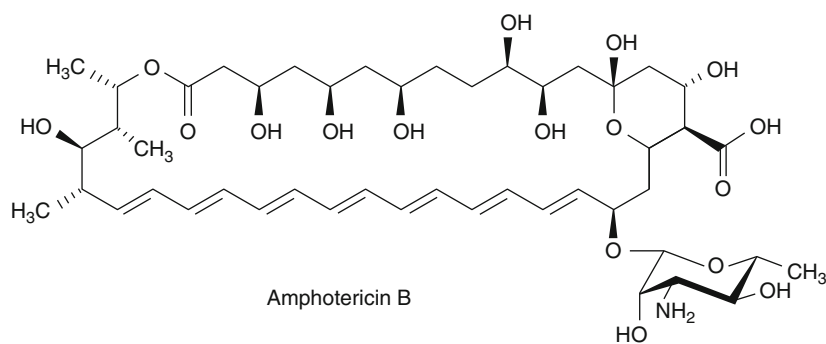

■ Fig. 9.5
Amphotericin

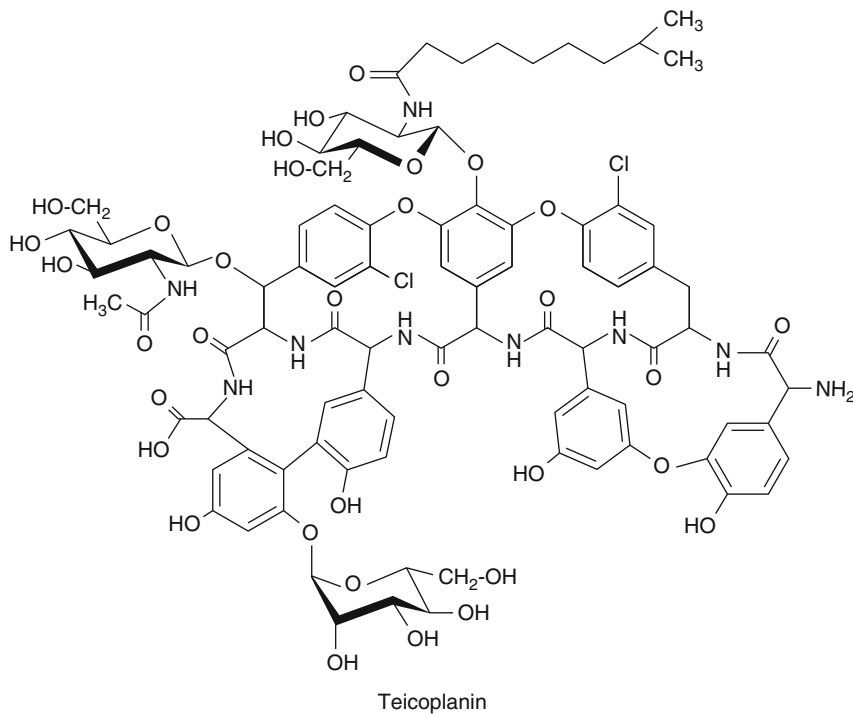
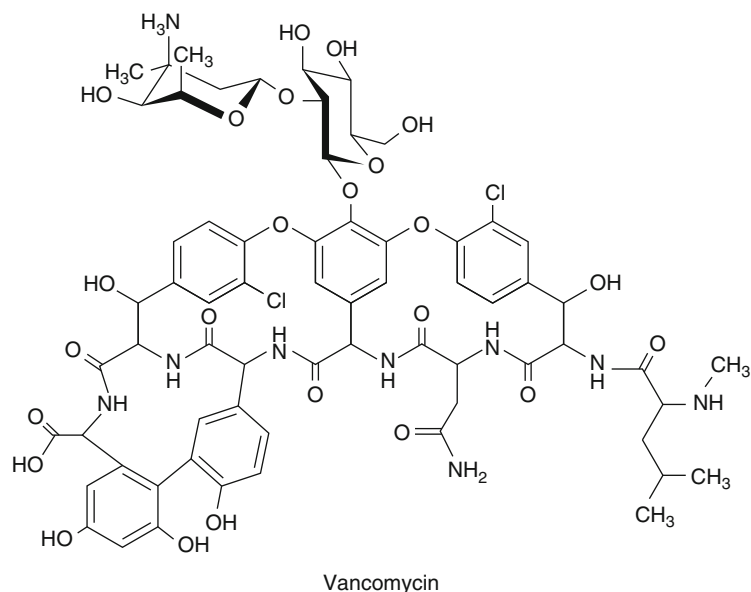

■ Fig. 9.6
Glycopeptides

Glycopeptides. Among the vast class of peptide antibiotics, the only ones commonly used are members of this family, denoted as “dalbaheptides” in view of their mechanism of action (d-alanine-D-alanine binding) and their composition (*heptapeptides*). The most well known are vancomycin and teicoplanin, produced by *Amycolatopsis orientalis* and *Actinoplanes teichomyceticus*, respectively (● Fig. 9.6).

Rifamycins. This family belongs to the large class of ansamycins, molecules characterized by an aromatic nucleus

spanned by an aliphatic (ansa) chain. Their mechanism of action is inhibition of RNA synthesis by binding to RNA polymerase. Industrially produced are rifamycin B and rifamycin SV, from *Amycolatopsis mediterranei*. These are the starting materials for the synthesis of rifampicin or rifapentine, clinically used semi-synthetic derivatives (● Fig. 9.7).

There are a few important antibiotics not belonging to any of the large families. These include chloramphenicol and lincomycin, both having a mechanism of action similar to

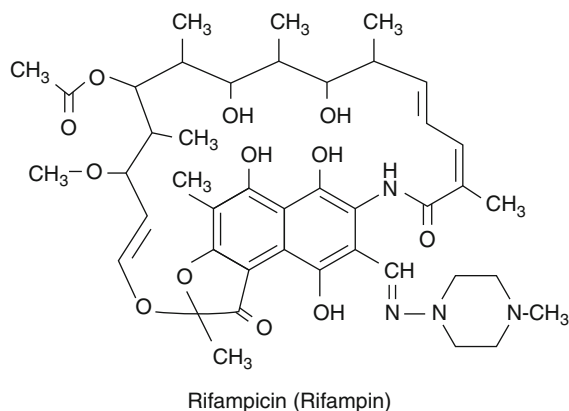

■ Fig. 9.7
Rifampicin (rifampin)

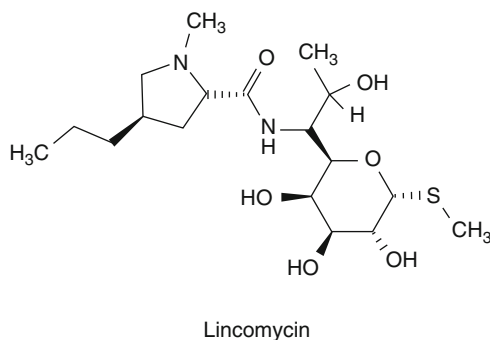

■ Fig. 9.8
Lincomycin

that of erythromycin. Chloramphenicol was isolated from *Streptomyces venezuelae* but is now produced by chemical synthesis. Lincomycin is the product of *Streptomyces lincolnensis* (► Fig. 9.8).

Nonclassical Antibiotics

About 40 years ago, the difficulty and high cost of isolating novel structures and agents with new antimicrobial modes of action became apparent and the field looked like it might enter a phase of decline. This is understandable considering the probability of finding useful antibiotics from microbes is 1 from 10,000 to 100,000 cultures examined (Fleming et al. 1982; Woodruff et al. 1979; Woodruff and McDaniel 1958). Indeed, the number of anti-infective investigational new drugs (INDs) declined by 50 % from the 1960s to the late 1980s (DiMasi et al. 1994).

Prior to the 1980s, bacterially produced antibiotics were the mainstay of control of pathogenic organisms in humans (β -lactams, chloramphenicol, tetracyclines, erythromycin, streptomycin, gentamicin, rifampicin, vancomycin, lincomycin), in foods (nisin), in animals (monensin) and in plants (polyoxins). However, new antibiotics were clearly needed because of (1) the development of resistance in pathogens; (2) the evolution of new

diseases (e.g., AIDS, Hantavirus, Ebola virus, *Cryptosporidium*, Legionnaire's disease, Lyme disease, and *Escherichia coli* 0157:H7); (3) the existence of naturally resistant bacteria (Stephens and Shapiro 1997), e.g., *Pseudomonas aeruginosa* (causing fatal wound infections, burn infections, and chronic and fatal infections in the lungs of cystic fibrosis patients), *Stenotrophomonas maltophilia*, *Enterococcus faecium*, *Burkholderia cepacia*, and *Acinetobacter baumannii* (Tenover and Hughes 1996); and (4) the toxicity of some of the approved compounds (Strohl 1997). Other organisms existed which were not normally virulent but did infect immunocompromised patients (Morris et al. 1998). By chemical or biological techniques, chemists had been improving antibiotics for many years. Despite the success of many semisynthetic antibiotics, new screening techniques were sorely needed in the 1970s and 1980s to isolate new bioactive molecules from nature. Two approaches were successful in improving the efficiency of screening: the isolation of actinomycete strains different from streptomycetes and novel tests that could indicate directly in fermentation broths the antibiotic mechanism of action.

The first approach was applied at the Schering-Plough Laboratories in the 1960s (Weinstein 2004). The company had acquired a collection of *Micromonospora* strains to assess their ability to transform steroids into novel derivatives. A few cultures were forwarded to the antibiotic screening section of the microbiology department. Preliminary test revealed the frequent presence of antibiotic activity; therefore, a screening program was immediately started. An important aspect of the program was to select among the many active cultures those whose crude extracts were able to cure an experimental infection in mice. In a short time, several active novel compounds were isolated and characterized, among which gentamicin appeared particularly attractive especially for its activity in vitro and in vivo on *Pseudomonas* and *Proteus* (Weinstein et al. 1963). Gentamicin was produced by *Micromonospora purpurea* as a complex of three components, gentamicins C₁, C₂, and C₃, practically identical in their biological activities, and as such was developed for clinical topical and systemic use and marketed in 1969. In the following years, sales grew to \$500 million annually.

A program for the isolation of rare *Actinomycetales* genera was started in 1966 at the Lepetit Research Laboratories (Lancini 2006). By microscopic examination of colonies on agar plates, strains displaying unusual morphology were picked and cultivated. By this approach in 2 years, four new genera were discovered, *Dactylosporangium*, *Planomonospora*, *Microtetraspora*, and *Planobispora*. However, this method was too laborious for a large screening program since only a few strains could be isolated in a reasonable period of time. A method for mass isolation of uncommon actinomycetes was devised, based on the fact that unlike streptomycetes, some genera produce motile spores. Soil samples were dispersed in water and settled by centrifugation. Motile spores soon migrated into the supernatant, where they could be collected in large numbers. The system was particularly effective for isolating *Actinoplanes* spp., and during 1971, several thousand strains were isolated and cultured. Novel antibiotics

were found, none of which, however, presented a potential clinical efficacy. To select among the thousands of active broths those producing nontoxic antibiotics, a simple test was devised which involved determining antibiotic activity in parallel toward an *S. aureus* strain and an isogenic L-form. Broths active against the normal strain but inactive against the L-form were considered to contain an inhibitor of cell wall synthesis. The combination of screening *Actinoplanes* strains and selecting products inhibiting cell wall synthesis led to the discovery of some interesting antibacterial agents: gardimycin in 1971, teichomycins in 1972, and ramoplanin and lipiarmycin in 1975.

Gardimycin (later called “actagardine”) was the first known example of a new group of lantibiotics characterized by their globular structure and their mechanism of action, inhibition of peptidoglycan synthesis by binding to lipid II (Coronelli et al. 1976) [the second example, mersacidin, was described nearly 20 years later (Chatterjee et al. 1992)]. Gardimycin, produced by *Actinoplanes garbadinensis*, has a narrow spectrum of activity restricted to streptococci. In spite of its low toxicity and noteworthy efficacy in curing experimental infections, it was never developed due to lack of activity toward *S. aureus*. Years later, it was found that some derivatives demonstrated a significant efficacy in experimental infections of enterococci. However, this indication was not further pursued.

Actinoplanes teichomyceticus produces several antibiotics, of which teichomycin A₂ (now called “teicoplanin”) is of particular interest. Teicoplanin is a complex of five glycopeptide antibiotics differing in the structure of their fatty acid moieties (Borghi et al. 1984). The components have quite similar biological properties, and therefore, teicoplanin was developed as one anti-infective agent (Pallanza et al. 1983). It has a similar spectrum, properties, and mechanism of action as vancomycin; however, it showed more favorable pharmacokinetics, being therapeutically effective when administered either i.v. or i.m. once daily, in contrast to vancomycin which had to be administered i.v. every 6 hours (Parenti et al. 2000). Teicoplanin was introduced in several European countries in the early 2000s and at present is largely used in all the important Asian countries also.

Ramoplanin, an antibiotic produced by *Actinoplanes* sp. ATCC 33076, is an inhibitor of peptidoglycan synthesis, which acts by sequestering lipid II (Cavalleri et al. 1984). It attracted the attention of medical bacteriologists because of its excellent bactericidal activity against important pathogens, such as *E. faecium*, *C. difficile*, and methicillin-resistant *S. aureus*. The product is not absorbed orally and when administered i.v. is effective in curing several infections but induces severe lesions at the site of injection. At present, it is being orally tested in clinical phase II for the cure of *C. difficile* infections. Recently, it has been proposed for the decontamination of *E. faecium* in the gastrointestinal tract.

Lipiarmycin is a narrow-spectrum macrocyclic antibiotic discovered at Lepetit (Coronelli et al. 1975) which has been recently approved as an oral agent against *C. difficile* infections under the name of fidaxomicin.

In 1954, Merck & Co., Inc., established in Spain at CEPA a laboratory devoted to screening for antibiotics. The “screening

program” at CEPA proved successful in the discovery of novel active compounds, but none of them presented the degree of safety needed for clinical application. An original test, based on mode of action, was devised, consisting of microscopically observing the formation of spheroplasts in cultures of Gram-negative cells to which filtrates of active broth had been added (Strohl et al. 2001). Introduced in mid-1960s, the new program yielded in the following years three antibiotics clinically effective, as such or as simple derivatives: fosfomycin in 1969, cefoxitin in 1972, and thienamycin in 1976.

Fosfomycin, produced by *Streptomyces fradiae*, proved of interest because of its great safety and broad spectrum. However, it was not orally effective toward systemic infections and is used in the UK, in the USA, and in several other countries as an oral formulation for the treatment of urinary infections. In a few countries, but not in the UK or USA, i.v. formulations are used for the treatment of systemic infections (Hendlin et al. 1969).

Considering the high number of actinomycete broths positive in the protoplast assay, the necessity was felt of introducing an additional test to select products active on cell wall but resistant to β -lactamases. The extracts from a strain of *Nocardia lactamadurans* appeared to possess these properties. The product, named cephamycin C, was in fact effective against several penicillin- or cephalosporin-resistant organisms but not sufficiently active against many Gram-positive pathogens. Therefore, a program of chemical modification was initiated, which led to the synthesis of cefoxitin, an important clinically effective antibiotic (Little and Peddie 1978).

The most important antibiotic discovered during the Spain laboratory screening program is thienamycin, a product of a new species named *S. cattleya* (Kahan et al. 1979). Thienamycin is the most potent and broadest in spectrum of all antibiotics known today. Although a β -lactam, it is not a member of the penicillins or cephalosporins; rather, it is a carbapenem, differing from the conventional β -lactams by the presence of a carbon atom instead of sulfur in the ring condensed to the lactam ring and by the *trans* configuration of the hydrogen atoms of the lactam ring (Birnbaum et al. 1985). It is bactericidal against aerobic and anaerobic bacteria, both Gram positive and Gram negative, including *Pseudomonas*. Similar to those of the other bacterial β -lactams, thienamycin's mode of action is inhibition of peptidoglycan synthesis; however, it is not affected by most bacterial β -lactamases and is therefore active against resistant strains. It is chemically rather unstable, but chemists were able to eliminate this problem by modifying the molecule. The new derivative, named imipenem, was not only more stable but also twice as active as the original molecule. In humans, imipenem was found to be metabolized by an enzyme in the kidney, renal dehydropeptidase-I, which acts as a β -lactamase (► Fig. 9.9).

Because the enzyme appeared to serve no essential role in human metabolism, scientists were able to develop a synthetic competitive inhibitor, cilastatin, which they then used with imipenem to produce the combination drug, primaxin (Tienam). Primaxin was introduced into medical practice in 1985.

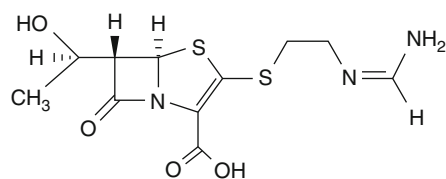

Imipenem (a semisynthetic thienamycin)

Fig. 9.9

Imipenem (a semisynthetic thienamycin)

Search for New Antibiotics in the Following Decades

Microbiologists knew in the 1970s–1980s that antibiotic technology had not yet defeated infectious microorganisms owing to resistance development in pathogenic microbes. Indeed, antibiotics probably can never win the war against infection permanently, and we have to be satisfied to stay one step ahead of the pathogens for a long time to come. Thus, the search for new natural product drugs and their improved semisynthetic derivatives slowed down but fortunately was not stopped. Clinical isolates of penicillin-resistant *Streptococcus pneumoniae*, the most common cause of bacterial pneumonia, increased in the United States from 1987 to 1992 by 60-fold (Breiman et al. 1994). Methicillin-resistant *Staphylococcus* infections increased to an alarming extent throughout the world (Goldman et al. 1996). At that time, vancomycin was the molecule of choice to treat these infections; however, resistance was developing to this glycopeptide antibiotic, especially in the case of nosocomial *Enterococcus* infections. We report here the new products, natural or semisynthetic, that attained a significant clinical use in the treatment of infectious diseases.

One group of useful narrow-spectrum compounds is the streptogramins, which are synergistic pairs of antibiotics made by single microbial strains. The pairs are constituted by a (group A) polyunsaturated macrolactone containing an unusual oxazole ring and a dienylamide fragment and a (group B) cyclic hexadepsipeptide possessing a 3-hydroxypicolinoyl exocyclic fragment. Such streptogramins include virginiamycin and pristinamycin (Barriere et al. 1998). Although the natural streptogramins are poorly water soluble and cannot be used intravenously, new derivatives have been made by semisynthesis and mutational biosynthesis. Synercid (RP59500) is a mixture of two water-soluble semisynthetic streptogramins, quinupristin (RP57669) and dalfopristin (RP54476), which has been approved for i.v. treatment of resistant bacterial infections (Nichterlein et al. 1996). The two Synercid components synergistically (100-fold) inhibit protein synthesis and are active against vancomycin-resistant enterococci and methicillin-resistant staphylococci (Stinson 1996). Another product, called pristinamycin has been developed for oral treatment of community-acquired infections and was approved for clinical use in Belgium and France. It is a co-crystalline association of two minor natural streptogramins (pristinamycin IB and pristinamycin IIB) produced by *Streptomyces pristinaespiralis*.

To contrast the widespread diffusion of pathogens resistant to natural and semisynthetic classical tetracyclines, a new series of derivatives, the glycylcyclines, have been synthesized (Sum et al. 1998). These modified tetracyclines show excellent activity against Gram-positive and Gram-negative bacteria, including strains that possess tetracycline-resistance determinants. Among them, a derivative of minocycline was chosen for development. Its spectrum of activity includes pathogens resistant to antibiotics other than tetracyclines, such as methicillin-resistant staphylococci and vancomycin-resistant enterococci. The product, named “tigecycline,” was approved by the FDA in 2005 as an injectable anti-infective agent (Sum 2006).

The cyclic lipopeptide antibiotic daptomycin, produced by *Streptomyces roseosporus*, was discovered in the late 1980 by Lilly (Debono et al. 1988). It presents excellent activity against most clinically relevant Gram-positive bacteria, including clinical isolates of methicillin-resistant *S. aureus* and vancomycin-resistant *Enterococcus* strains. Its mode of action differs from that of any other clinically useful antibiotics: it binds to bacterial cell membrane, disrupting several membrane functions, and, consequently shows a strong bactericidal effect. During preliminary clinical tests, severe side effects were observed. However, it was later demonstrated that these were due to the excessive dosage applied, and a good curative efficacy could be obtained administering lower safe doses. Daptomycin was approved in 2003 by FDA for skin infections, but in the following years, several other indications were admitted.

Two successful semisynthetic derivatives of erythromycin were discovered at the beginning of the 1980s, azithromycin and clarithromycin. Both are more stable to gastric acid than erythromycin and consequently, in comparison with the parent product, show an improved oral absorption and gastric tolerability. In the following years, a new family of semisynthetic macrolides, the ketolides, were obtained, characterized by their activity on some pathogens resistant to macrolides, fluoroquinolones, and other antibiotics such as penicillins. The most promising member of the family, telithromycin, was developed and in 2001 approved in Europe for the treatment of community-acquired respiratory tract infections. Approval by FDA was granted in 2004 (Scheinfeld 2004).

Clavulanic acid is produced by *Streptomyces clavuligerus*, together with cephamycin C. It belongs to the clavam subgroup of the β -lactam antibiotics, characterized by a structure comprising an oxazolidine ring. It was first described in 1976 (Birnbaum et al. 1978) and shown to be a potent inhibitor of β -lactamases, the penicillin-inactivating enzymes produced by staphylococci and several Gram-negative pathogens. Therefore, clavulanate is used in combination with different penicillins to enlarge their spectrum of activity. The combination with amoxicillin, denoted “augmentin,” is widely used orally (Brown 1986). Severe infections are treated parenterally with the combination clavulanate-ticarcillin.

Telavancin is a semisynthetic derivative of vancomycin characterized by the presence of a medium-length fatty acid linked as an amide to a sugar of the parent molecule. Similarly to teicoplanin, telavancin shows an improved pharmacokinetic

behavior and can be administrated once daily (Higgins et al. 2005). It was approved by FDA in late 2009 for the treatment of complicated skin infections. Recently, it has been proposed for a second indication, nosocomial pneumonia.

Antitumor Agents

Microbial metabolites are among the most important cancer chemotherapeutic agents. More than 60 % of the approved small molecules drugs are either natural products or modified natural products (Newman and Cragg 2007). Most of these are products of streptomycetes, and were discovered testing for their activity against tumor cells. The molecules, detected in the screening, that were too toxic to be used as anti-infective drugs. Generally, these agents act by permanently damaging, although through different mechanisms, the DNA of growing cells with a rapid lethal effect.

Actinomycins have essentially a historic importance, being the first antibiotics isolated from a streptomycete, *Actinomyces antibioticus* (Waksman and Woodruff 1941). Due to their toxicity, clinical application was not considered for years, but they attracted much attention after their antitumor activity in animals was demonstrated. However, at the curative doses, their toxicity was in general too high for allowing human clinical use and was used primarily as investigating tools for studies of molecular biology. The only substance that found a clinical application is actinomycin D (dactinomycin), in use since 1964 for the treatment of Wilms' tumor in children.

Streptomyces caespitosus produces several mitomycins, antibiotics that show an excellent antitumor activity but of limited utility because of their toxicity. The only substance acceptable for human use is mitomycin C, approved by FDA in 1974. Mitomycin C acts by forming covalent bridges across two opposite DNA strands, causing a rapid cell death (Tomasz 1995). In contrast to most antitumor agents, it is also active against the hypoxic cells in the core of solid tumors and therefore is indicated for the treatment of specific type of neoplasms such as gastric, colorectal, and lung cancer.

The anthracyclines are among the most effective antitumor antibiotics, being active against more types of cancer than any other chemotherapy agent. The first anthracycline discovered was daunorubicin, a product of *Streptomyces peucetius*, described in 1966. A year later, doxorubicin was reported, the product of a variant of the same microorganism, widely known as Adriamycin, the most effective agent of the family. It is used to treat lymphomas, leukemias, and breast, uterine, ovarian, and lung cancers (Minotti et al. 2004). Their main adverse effect is a cumulative dose-related cardiotoxicity, which prevents the repetition of chemotherapy treatment more than once. Among the many derivatives – natural or semisynthetic – tested, epirubicin appeared to cause fewer side effects and was approved by FDA in 1999. A new totally synthetic analog of doxorubicin, denoted amrubicin, has been introduced since 2002 into the Japanese market. It is claimed to be almost devoid of cardiotoxicity. At

present, it is in advanced phase II clinical trials for the treatment of small cell lung cancer, with positive results (Ogawara et al. 2010).

Bleomycins are a family of structurally related compounds produced by *Streptomyces verticillus* (Umezawa et al. 1966). They act through a peculiar mechanism, causing nicks in DNA strands by a complex reaction involving oxygen and metals. A mixture of bleomycins A2 and B2 was introduced in clinics in 1966 for the treatment of squamous cell carcinomas and malignant lymphomas and is still used, mainly in combinations.

A few antitumor antibiotics whose use is strictly limited to a single indication deserve a brief mention. Streptozotocin, produced by *Streptomyces achromogenes*, is selectively active against β -cells of pancreatic islets. It was approved by FDA in 1982. Pentostatin (deoxycoformycin), a product of *Streptomyces antibioticus*, although rather toxic, is used to treat some forms of leukemia. The FDA granted approval for pentostatin in 1993.

Enediynes are a large class of antibiotics comprising two families, the neocarzinostatins and the calicheamicins. The enediynes are endowed with an exceptional antitumor activity but are too toxic to be proposed for clinical use. To overcome this problem, calicheamicin gamma (ozogamicin), a product of *Micromonospora echinospora*, has been linked to a humanized monoclonal antibody specific for some cancer type. Gemtuzumab-ozogamicin was approved by FDA in 2001 for some form of leukemia (Giles 2002). However, in 2010 the drug was withdrawn from the market because a post-approval clinical trial raised serious doubt about the drug's safety and efficacy. At the same time, another agent was developed, inotuzumab-ozogamicin, in which the same calicheamicin is linked to a different antibody. This new agent is undergoing several clinical trials, one of which has recently completed a phase III trial.

Epothilones are a family of very promising new anticancer agents produced by *Sorangium cellulosum*, a myxobacterium. They act by stabilizing microtubulins, similarly to taxanes, but they also inhibit the overexpression of P-glycoprotein efflux pumps (Bollag et al. 1995). Ixabepilone, an orally effective semi-synthetic derivative of epothilone B, was approved by FDA in 2007 for the treatment of advanced breast cancer. This product is undergoing further clinical trials for other indications. At the same time, the natural compound epothilone B (patupilone) is currently being evaluated in phase III clinical trials against a variety of tumors (Goodin et al. 2004) (● Fig. 9.10).

Other Bioactive Metabolites

It was pointed out in the 1970s and 1980s (for review, see (Demain 1983) that compounds with antibiotic activity also exhibit other valuable activities, some of which had been quietly exploited in the past, and that such broadening of scope should be exploited and expanded in the future. Thus, a broad screening of antibiologically active molecules for activity against organisms other than microorganisms, as well as for activities having other pharmacological applications, was proposed to yield new and useful lives for "failed antibiotics." A large number of simple in vitro

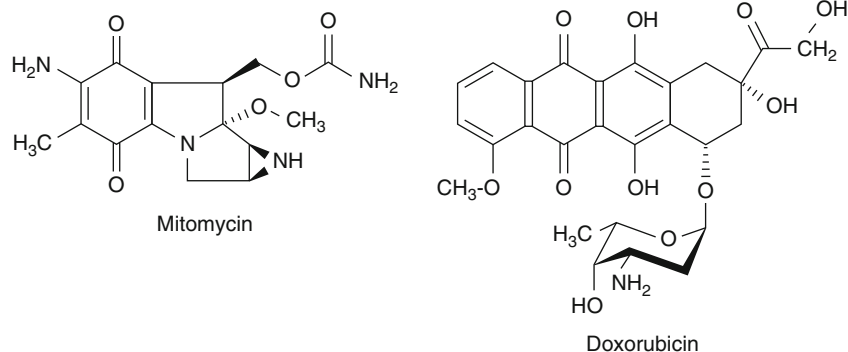

■ Fig. 9.10
Antitumor agents

laboratory tests were developed to detect, isolate, and purify useful compounds. Much of this emphasis was brought about by the writings of Hamao Umezawa (Umezawa 1972, 1982), who pointed out the potential importance of enzyme inhibitors as drugs. Fortunately, we entered into a new era in which microbial metabolites were applied to diseases (not caused by bacteria and fungi) heretofore only treated with synthetic compounds. Successes were achieved in the following different areas.

Immunosuppressive Agents

Cyclosporine A was originally discovered as a narrow-spectrum antifungal peptide produced by a mold (Borel et al. 1976). Discovery of its immunosuppressive activity led to its use in heart, liver, and kidney transplants and to the overwhelming success of the organ transplant field. Although cyclosporine A had been the only immunosuppressant on the market for many years, two other products, produced by actinomycetes, are providing new opportunities. These are the polyketides FK-506 (tacrolimus) and rapamycin (sirolimus), both narrow-spectrum antifungal agents, which are more potent than cyclosporine as immunosuppressants and less toxic.

Sirolimus (rapamycin) (Vezina et al. 1975) is widely used to prevent rejection in organ transplant. It is especially useful in kidney transplants because, different from cyclosporine and tacrolimus, it is not a calcineurin inhibitor and therefore is less toxic to the kidney. Sirolimus inhibits T-cell and B-cell activation. It binds to the immunophilin FKprotein12, and this binary complex inactivates a serine-threonine kinase (mTOR) termed the mammalian target of rapamycin (Huang et al. 2003). The final effect is the arrest at phase G1 of cell cycle progression. This effect occurs not only in T cell and B cells, but it has been observed in many tumor cell lines. Semisynthetic derivatives of rapamycin, suitable for i.v. administration, have been developed as antitumor agents. Temsirolimus was approved by FDA in 2007 for advanced kidney cancer treatment (Hudes 2009). Everolimus was also approved for kidney cancer treatment in 2009 and for organ rejection prophylaxis in 2010. At present, phase III clinical trials are under way in a variety of tumors (Dansey 2006).

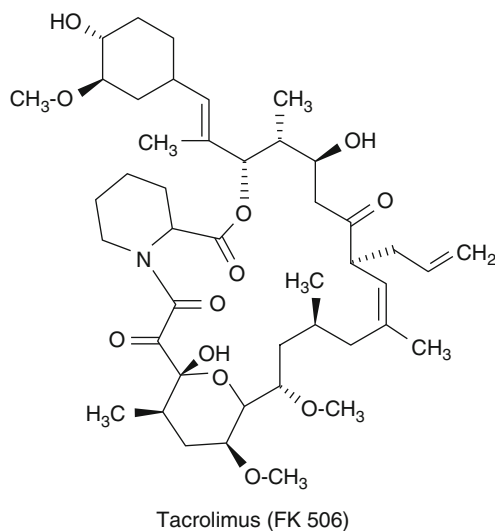

■ Fig. 9.11
Tacrolimus (FK-506)

Tacrolimus (FK-506) is an extremely effective immunosuppressive agent, being approximately 100 times more active than cyclosporine A (Kino et al. 1987). Its mechanism of action is quite similar to that of cyclosporines. Tacrolimus binds to immunophilin FKprotein12, and this binary complex inhibits calcineurin, which is responsible for activating the transcription of interleukin-2 (Liu et al. 1991). It was approved by FDA in 1994 for use in liver transplantation. Subsequently, its use has been extended to include bone marrow, cornea, heart, lung, and other transplants (🔗 Fig. 9.11).

Enzyme Inhibitors

In addition to the enzyme inhibitors produced by fungi used to lower cholesterol (statins), several bacterial enzyme inhibitors have also been studied for potential utilization in medicine. The most important is clavulanic acid, the inhibitor of β -lactamases discussed above in the section 🔗 “Search for New Antibiotics in the Following Decades.”

Several enzyme inhibitors are useful for the control of carbohydrate-dependent diseases, such as diabetes. One of these is acarbose, a pseudopolysaccharide produced by an *Actinoplanes* strain. Acarbose inhibits intestinal α -glucosidase thus reducing the conversion of starch into glucose (Truscheit et al. 1981). Other enzymes, the protein α -amylases from plants, are effective inhibitors of human α -amylases, in contrast with several α -amylases isolated from streptomycetes (e.g., pamI and Haim II) which are active in various animals but not in humans. However, a new polypeptide, Al-409, produced by *Streptomyces chartreusis* was recently shown to be active on human salivary α -amylase, opening the way to further studies (Imada 2004).

Lipstatin is a pancreatic lipase inhibitor produced by *Streptomyces toxytricini* that interferes with intestinal absorption of fats. A semisynthetic derivative, tetrahydrolipstatin, has been introduced into the market as an antiobesity agent. It appears to be also useful in managing the effects of diabetes (Weibel et al. 1987).

Enzyme XO catalyzes the oxidation of hypoxanthine to uric acid. An inhibitor of XO, hydroxyakalone, has been isolated from cultures of *Agrobacterium aurantiacum*, a marine microorganism. This inhibitor is potentially useful for prevention and cure of gout (Izumida et al. 1997).

Insecticides and Antiparasitic Agents

Spinosins are a family comprising over 20 metabolites produced by *Saccharopolyspora spinosa*. Although devoid of antibiotic activity, they are active against a variety of insects noxious to plants, especially Lepidoptera and Diptera (Kirst et al. 1991). Their use is safe in regard to humans and other animals, since they selectively disrupt the insect nervous system specifically targeting two key neurotransmitter receptors, γ -aminobutyric acid receptor and a subtype of nicotinic acid receptor. Spinosad, a mixture of spinosin A and D produced by fermentation, is largely used as the active ingredient of several commercial products (Thompson et al. 2000). In addition, it has been approved in several countries for use in organic agriculture. A number of semisynthetic derivatives were chemically prepared starting with a mixture of the natural products spinosin J and L. This effort was directed by SAR studies, with the help of an artificial intelligence model of the neural network. The final result was spinetoram, which showed greater potency and longer duration of insect control in comparison with spinosad, while retaining a low environmental effect on nontarget species. Spinetoram has been successfully developed as a new commercial product for insect control on a variety of agricultural crops (Kirst 2010).

One of the major economic diseases of poultry is coccidiosis caused by species of the parasitic protozoan, *Eimeria*. For years, this disease was treated solely by synthetic chemicals. Although they were generally effective, resistance developed rapidly in the coccidia, and new chemical modifications of the existing coccidiostats had to be made. Surprisingly, a parenterally toxic and narrow-spectrum antibiotic, monensin, was found to have orally an extreme potency against coccidia (Haney and Hoehn 1968). Even with this finding, there were grave doubts that the

fermentation process for this polyether compound could be improved to the point where monensin would become economical for use on the farm. However, the power of industrial genetics and biochemical engineering is so great that there is almost no limit to the improvements possible in a fermentation process. As a result, the polyether antibiotics, especially monensin (produced by *Streptomyces cinnamonensis*), lasalocid (produced by *Streptomyces lasaliensis*), and salinomycin (produced by *Streptomyces albus*; (Westley 1977)), dominate the commercial coccidiostat field today.

Another major veterinary problem has been the infection of farm animals by worms. The predominant type of screening effort over the years was the testing of synthetic compounds against nematodes, and some commercial products did result. Certain antibiotics also had been shown to possess antihelminthic activity against nematodes or cestodes, but these failed to compete with the synthetic compounds. Further screening of microbial broths for antihelminthic activity yielded a nontoxic fermentation broth that killed the intestinal nematode, *Nematospiroides dubius*, in mice. The *Streptomyces avermitilis* culture, which was isolated by Omura and coworkers at the Kitasato Institute in Japan, produced a family of secondary metabolites having both antihelminthic and insecticidal activities, which were named "avermectins" (Stapley 1982; Ikeda and Omura 1997). They are disaccharide derivatives of macrocyclic lactones with exceptional activity against parasites, i.e., at least ten times higher than any synthetic antihelminthic agent known. Despite their macrolide structure, avermectins lack activity against bacteria and fungi; they interfere with neurotransmission in many invertebrates. They have activity against both nematode and arthropod parasites in sheep, cattle, dogs, horses, and swine. A semisynthetic derivative 22,23-dihydroavermectin B1 (ivermectin) is 1,000 times more active than thiobenzole and is a commercial veterinary product. A new avermectin, called "Doramectin" (cyclohexylavermectin B1), was developed by the technique of mutational biosynthesis (McArthur 1998). Indeed, it was the first commercially successful example of mutational biosynthesis. The natural avermectins contain C-25 side chains of 2-methyl butyryl ("a" components) or isobutyryl ("b" components). Branched-chain 2-keto acid dehydrogenase was eliminated from the parent culture by knocking out gene *bkd* (Hafner et al. 1991; Chen et al. 1989); this strain produced no avermectin unless fed isobutyric acid or (S)-2-methylbutyric acid. Upon feeding other fatty acids, novel avermectins were made (Dutton et al. 1991). More than 800 fatty acids were tested, yielding over 60 avermectins including cyclohexyl B1 avermectin (doramectin), which resulted from incorporation of cyclohexane carboxylic acid. Doramectin is claimed to have some commercial advantages over ivermectin (Goudie et al. 1993).

A fortunate fallout of the avermectin work was the finding that ivermectin has activity against the blackfly vector of human onchocerciasis (river blindness). It interferes with transmission of the filarial nematode, *Onchocerca volvulus*, to the human population. Because this disease affects 40 million people, the decision by Merck to supply ivermectin free of charge to the

World Health Organization for use in humans in the tropics was met with great enthusiasm and hope for conquering this parasitic disease.

Biochemical and Genetic Aspects of Secondary Metabolism

There is no longer any doubt that antibiotics and other secondary metabolites are produced under natural growth conditions and have a physiological role. Over 40 % of actinomycetes produce antibiotics when they are freshly isolated from nature. Soil, straw, and agricultural products often contain antibacterial and antifungal substances. Bacterially produced siderophores have been found in soil, and microcins, enterobacterial antibiotics, have been isolated from human fecal extracts. The microcins are thought to be important in bacterial colonization of the human intestinal tract early in life. A further indication of natural antibiotic production is the possession of antibiotic-resistance plasmids by most soil bacteria. The widespread nature of secondary metabolite production and the preservation of the multigenic biosynthetic pathways in nature indicate that secondary metabolites serve survival functions in organisms that produce them. There are a multiplicity of such functions, some dependent on antibiotic activity and others independent of such activity. Indeed, in the latter case, the molecule may possess antibiotic activity but may be used in nature for an entirely different purpose. These functions include metal transport, bacteria-plant symbiosis, plant growth stimulation, bacteria-nematode symbiosis, and induction of morphological and chemical differentiation (Demain 1989).

It is now widely accepted that secondary metabolism represents a form of cellular differentiation. In prokaryotes and in other microorganisms, differentiation is comprised of morphological differentiation (morphogenesis, sporulation, and germination) and physiological (or chemical) differentiation (production of secondary metabolites). One important difference is that morphological differentiation is characteristic of a taxonomic group of organisms, normally a genus, whereas production of a given secondary metabolite is a characteristic of one or a few strains not necessarily related taxonomically. In the cases thoroughly studied, such as *Bacillus subtilis* and *Streptomyces coelicolor*, it has been observed that the two forms of differentiation share some of the early genes involved in regulation. In *Bacillus*, the transcription of the sporulation genes, as well as that of genes involved in secondary metabolism, is totally dependent on the *SpoOA* gene product. The activated forms of gene products *SpoOA* and *SpoOF* set off the sporulation regulatory cascade. In this cascade, one of the steps is the repression by *SpoOA* of the *abrB* gene. The *abrB* gene product represses transcription of genes *tycA* and *tycB* governing the biosynthesis of tyrocidine. Derepression of transcription initiates the synthesis of this antibiotic. In *S. coelicolor*, inactivation of the *bld* genes hinders both the formation of aerial mycelium and the production of antibiotics. Inactivation of the *whi* genes (that follow the *bld* genes in the morphological differentiation cascade) blocks

the development of aerial mycelium into spores but allows the production of the antibiotics. Vice versa, mutations in genes *absA* and *absB* result in normal sporulation but absence of antibiotic production (Chater and Bibb 1997).

Relevant evidence that morphological secondary metabolism and chemical secondary metabolism (i.e., production of antibiotics) are connected is that initiations of both events occur at the same growth phase. It is well known that antibiotic production in liquid cultures generally starts at the end of logarithmic growth, i.e., at the entry into stationary phase, which is a form of morphological differentiation. On solid substrates, streptomycetes grow as a network of hyphae constituting the vegetative mycelium. When, upon the depletion of an essential nutrient, the vegetative growth ceases, morphological differentiation occurs at the expense of substrate mycelium, which lyses, releasing the nutrients necessary for the aerial hyphae growth (Ensign 1992). It has been demonstrated that antibiotic production in agar surface-grown cultures occurs at this stage of the streptomycetes growth cycle (Mendez et al. 1985; Bibb 1996).

The specific time of onset of secondary metabolite synthesis was obviously established by evolutionary pressure. Delay in secondary metabolite production until the initiation of differentiation makes sense if the product has a competitive function in nature. In nutritionally rich habitats, such as the intestines of mammals where enteric bacteria thrive, secondary metabolite production is not as important as in soil and water, where nutrients limit microbial growth. Thus, antibiotics tend not to be produced by enteric bacteria but by soil inhabitants such as bacilli, actinomycetes, and fungi. It is noteworthy that, for instance, *Pseudomonas* species living preferably in soil produce a number of antibiotics, whereas those living on plants generally produce toxins, molecules selectively acting against complex eukaryotes. Considering the *Streptomyces* life cycle, it appears that the time at which a defense is most needed is when the vegetative mycelium lyses, scattering the nutrients needed for the formation of aerial mycelium. Production of antibiotics can prevent competitors to scavenge for the nutrients.

Regulation of Secondary Metabolite Production

The mechanisms by which the limitation of essential nutrients induces antibiotic production are only partially understood. However, the organization of genes governing antibiotic production in many organisms has been elucidated and provides some reasonable general assumptions. In all the cases studied, the genes governing the production of a specific antibiotic are grouped in a cluster that includes, in addition to structural genes governing the production of the biosynthesis enzymes, regulatory genes, denoted "pathway-specific regulators," responsible for overall gene expression. Two families of pathway-specific regulators are known: the SARPs (streptomycetes antibiotic regulatory proteins) and the LAL (large ATP-binding regulators of the LuxR family). During vegetative growth, all the genes of the cluster are repressed, possibly constitutively, or in some cases, by specific repressors. The SARPs and apparently most of the other

pathway regulators are transcriptional activators. When the concentration of an essential nutrient falls below a certain level, a cascade of events is initiated whose final outcome is the derepression of a SARP gene. The protein thus produced activates the transcription of all the genes of the cluster. Overall, the system is such as to realize two important aims of antibiotic production regulation: (1) linking the production to a given phase of the growth cycle and (2) insuring that all the biosynthetic enzymes are produced at the same time. In addition, when the cluster contains a gene of the self-resistance mechanisms, its transcription is activated.

In some cases, the cascade of events linking the physiological condition to the cluster derepression has been clarified. In unicellular prokaryotes, when the cytoplasmic concentration of an amino acid falls below a given level, a complex cascade of events occurs, called the stringent response. Some mRNAs of the amino acid are uncharged and, binding to ribosomes, activate ribosomal protein Rel A, a synthetase converting GTP into guanosine tetraphosphate (ppGpp). The latter, binding to RNA polymerase, changes drastically its ability to recognize gene promoters. Those relevant for growth are not transcribed anymore, whereas those governing chemical and morphological secondary metabolism are activated. In streptomycetes, the overall effect of the stringent response is quite similar to that observed in other prokaryotes, although the intermediate steps present some difference. In particular, it has been shown that normally, the complex ppGpp-RNA polymerase complex selectively induces transcription of the pathway regulators and brings on antibiotic production (Hesketh et al. 2007).

Most actinomycetes produce small molecules, γ -butyrolactones, which are implicated in the onset of secondary metabolism. The best studied of these is A-factor of *Streptomyces griseus*. A characteristic of A-factor is that it is required for both secondary metabolite production and morphological differentiation. The mechanism by which A-factor operates is sufficiently understood. During the early stages of growth, the A-factor-specific receptor, ArpA, binds to the promoter region of *adpA* and represses its transcription. When the concentration of A-factor reaches a critical level, A-factor binds to ArpA and releases it from DNA, allowing the transcription of *adpA*. Protein *adpA* is a transcriptional activator of a number of genes of morphological development and of *strR* which encodes the pathway-specific activator for streptomycin biosynthetic genes (Kato et al. 2004). In contrast, most γ -butyrolactones appear to regulate specifically the production of secondary metabolites. A well-studied example is the virginiae butanolides which control virginiamycin production in *Streptomyces virginiae*. Another example is the regulation of tylosin production in *Streptomyces fradiae*. This comprises five regulatory genes, including two butyrolactone-binding protein homologues. Although the cognate butyrolactones are at present unidentified, it has been possible to propose a regulatory cascade involving four proteins in the activation of tylosin biosynthetic genes (Takano 2006).

Many genes have been identified in different *Streptomyces* species able to regulate, either positively or negatively, antibiotic production independently from the stringent response. Among

these two are especially important pleiotropic regulators activated by the environmental concentration of specific nutrients. These are the two-component system PhoR-PhoP and the system AfsK-AfsR.

An excessive concentration of phosphate in the culture medium prevents the production of many secondary metabolites. Recent studies have clarified the dominant role that a two-component system PhoR and PhoP in phosphate action regulation (Sola-Landa et al. 2003). PhoR is a transmembrane protein, sensing the environmental phosphate concentration. When the concentration falls below a given limit, PhoR is activated and phosphorylates PhoP. PhoP is a regulatory protein able, when thus activated, to recognize specific DNA sequences near the promoters of many different genes, of which they may either repress or promote transcription. In *Streptomyces*, activated PhoP represses several genes of primary metabolism, including *glnR*, encoding the major nitrogen metabolism regulator, and two genes encoding glutamine synthetases, *glnA* and *glnIII*. In secondary metabolism, two cases of phosphate control of antibiotic production stood out. It was demonstrated that the phosphate negative effect on the biosynthesis of candicidin of *Streptomyces griseus* and of oxytetracycline of *Streptomyces rimosus* was exerted at the transcriptional level, but the overall mechanism remained obscure (Martin 2004). In recent years, it was found that in several cases, antibiotics are overproduced upon deletion of *PhoP* or *PhoR-PhoP*, demonstrating the involvement of these genes in the regulation of secondary metabolism.

The cascade of events connecting phosphate concentration to secondary metabolism has been unraveled by studying the control of actinorhodin and undecylprodigiosin biosynthesis in *Streptomyces coelicolor* (Martin 2004). The signal transduction pathway, which regulates the derepression of the pathway-specific regulators of these antibiotics, comprises the two component system AfsK-AfsR that globally controls secondary metabolism. AfsK is a transmembrane protein which autophosphorylates in the presence S-adenosylmethionine and other unknown effectors. When activated, AfsK phosphorylates AfsR which is a regulatory protein structurally quite similar to the SARPs. Activated AfsR binds and derepresses the promoter of *AfsS*, a gene present in the clusters of several antibiotics. *AfsS* is a small protein that, induced in this way, activates the transcription of the SARPs. In *Streptomyces coelicolor*, *AfsS* induces the transcription of *actII-ORF4* and *redD* and consequently activates the biosynthetic genes for actinorhodin and undecylprodigiosin production, respectively (Horinouchi 2003). The phosphate regulator PhoP acts by binding to a sequence in the *AfsS* promoter overlapping with the AfsR binding site. The interaction of these two high-level regulators appears to integrate different environmental signals for the *AfsS*-mediated control of secondary metabolites.

Secondary Metabolite Biosynthetic Pathways

The study of the biosynthesis of secondary metabolites requires identification of the sequence of reactions by which one or more

primary metabolites are converted into the final molecule. The biosynthetic pathways of a vast number of antibiotics have been elucidated, both as a result of academic interest and for the practical outcome that such research can give, e.g., in increasing production yields of antibiotics of commercial interest and in obtaining molecules modified in their biological activity.

In contrast to the huge variety of chemical structures presented by antibiotic molecules, the sequences of biological reactions by which they are made can be grouped into three classes (Lancini and Lorenzetti 1993).

The Three Classes of Biosynthetic Reactions

Class I Reactions. These are the series of reactions by which a primary metabolite is converted into a small antibiotic molecule or into an intermediate of the synthesis of larger antibiotics. Typically, these series of reactions can be conveniently classified according to the pathways of primary metabolism with which they are related. We thus have antibiotics, or antibiotic moieties, whose biosynthesis is tied to amino acid synthesis or catabolism, nucleoside metabolism, or coenzyme synthesis (Lancini and Demain 1999). Chloramphenicol and clavulanic acid are examples of small antibiotic molecules biosynthesized through class I reactions. Chloramphenicol synthesis initiator is *p*-aminophenylalanine, which derives from a variation of tyrosine synthesis, and is modified by acylation, reduction, and final oxidation of the amino- into the nitro-group. The last is an uncommon enzymatic reaction, absent in primary metabolism. Clavulanic acid is a β -lactam, but its biosynthesis is quite different from that of penicillins or cephalosporins. It is initiated by the condensation of arginine with glyceraldehyde-3-phosphate to give carboxyethyl-arginine. The last molecule folds to form the β -lactam ring and then folds again to form the typical core of the clavam antibiotics.

A vast number of class I reactions are devoted to the synthesis of molecules that become part of larger structures. Typical of antibacterial macrolides and of glycopeptides is the variety of uncommon sugars that glycosylate the molecule's core structure. The sugars are synthesized by complex sequences of reactions starting from glucose or, rarely, glucosamine. In all the cases, the starting molecules and all the intermediates of the pathway are activated as nucleotide diphosphates. A well-studied example is the biosynthetic pathway of the erythromycin and tylosin sugars. The pathway starts with the conversion of dTDP-glucose into dTDP-4-keto-6-deoxyglucose, from which initiates a sequence of three reactions leading to formation of desosamine, a sugar decorating both tylosin and erythromycin. By epimerization of dTDP-4-keto-6-deoxyglucose into dTDP-4-keto-L-rhamnose, a second pathway initiates, leading to formation of dTDP-micarose, which glycosylates the desosamine of tylosin, and in addition, glycosylates the erythromycin molecule which is further modified into cladinose. Streptose, the sugar part of streptomycin structure, is also synthesized from dTDP-glucose through dTDP-4-keto-L-rhamnose.

Class II Reactions. The key steps in the biosynthesis of a number of antibiotics are polymerization reactions, by which several similar units are linked together to form the backbone of a larger molecule. On the biochemical basis and according to the similarity of the genes involved, the following types of polymerization reaction are recognized in bacteria:

Polyketide Synthesis

This is a mechanism of polymerization of small acid units (most often acetate or propionate; the actual molecules involved in the condensation process are malonate or methylmalonate) closely analogous to the mechanism of fatty acid synthesis (Katz and Donadio 1993). Two types of polyketide synthases (PKSs) are recognized:

Iterative Polyketide Synthases (Type II). These PKSs are characterized by an organization of the enzymes similar to that of fatty acid synthases (FAS) of most bacteria, in which each of the reactions necessary for the addition of a unit (condensation, reduction, etc.) is catalyzed by a single set of enzymes (Hopwood and Sherman 1990). The mechanism is iterative, in the sense that the same addition operations are repeated several times by the same set of enzymes, giving rise to a chain composed of identical elements. In iterative polyketide antibiotic synthesis, the chain extension molecule is always malonate, and reduction and dehydration steps are generally omitted. The resulting chain is composed of alternating methylene and keto groups (the term "PKS" is derived from the presence of the keto groups). Such a structure is highly unstable and tends to eliminate water by aldol condensation between keto and methylene groups. According to the length of the chain and the nature of the enzymes involved, many different structures can be formed; these tend to be aromatic owing to steric and energy factors. Two important families of metabolites are biosynthesized by iterative PKS: the antibacterial tetracyclines and the antitumor anthracyclines, e.g., doxorubicin. The basic structure of these molecules is comprised of four linearly condensed rings. The organization of the genes governing polyketide synthesis is quite similar in all the *Streptomyces* species examined. The gene encoding the ketosynthase, responsible for the condensation of the units, is adjacent to the gene encoding an essential protein, the chain length factor, which determines the length of the growing chain. This is followed by the gene encoding the acyl carrier protein to which the polyketide growing chain is attached by a thioester bond. Downstream are located the genes of the cyclases, enzymes essential for the correct folding of the chain, and the aromatases that catalyze the dehydration.

Modular Polyketide Synthases (Type I). In contrast to iterative PKSs, modular PKSs consist of one or more large proteins composed of synthase units called modules (Donadio et al. 1991). Each module performs an elongation step of the synthesis of the polyketide chain. In all the modules are present the enzymes necessary for the condensation of an extension unit of the growing chain: acylketosynthase (KS), acyltransferase (AT), and acyl carrier protein (ACP). In some modules, also present may be some or all of the enzymes devoted in fatty acid synthesis to the stepwise reduction of keto groups: ketoreductase

(KR), dehydratase (DH), and enoylreductase (ER). The biochemical mechanism of each step of extension is quite similar to that of iterative PKS, but the structural features of the growing chain vary: the extension units recognized by the module's acyltransferase may be, instead of malonate, methylmalonate, or ethylmalonate, originating methyl or ethyl substituted chains. The reduction of the keto group can give rise to hydroxyl substituents, double bonds, or contiguous methylenes. The modules are linearly arranged on the PKS protein, and the growing chain is transferred by ACP from one module to the next one. The length of the chain is determined by the number of modules and its structural features depend on the location of the modules on the protein and by the enzymes that these are comprised of. Since most of the keto groups are normally reduced, these chains, in contrast to those of the iterative PKSs, do not have a true polymethylene structure. Therefore, they cannot fold to form aromatic rings, and instead, either linear molecules or macrocyclic rings are formed. The basic structure of several important families of secondary metabolites are synthesized by modular PKSs: (1) the macrolide antibiotics, such as erythromycin, and the immunomodulators sirolimus and tacrolimus, characterized by a macrolactone ring; (2) the ansamycins, such as the rifamycins, whose basic structure is a macrolactam; (3) the ionophoric polyethers, such as monensin, characterized by a linear structure which includes several small rings closed by ether bonds; and (4) the linear antifungal polyenes such as amphotericin B.

Polymerization of Amino Acids

Polymerization by Polypeptide Synthetases. Typical of secondary metabolism is a mechanism of formation of polypeptides catalyzed by nonribosomal polypeptide synthetases (NRPSs) (Kleinkauf and von Döhren 1987). The NRPSs catalyze the activation and incorporation of monomers (amino- or hydroxy-acids) into oligomers (peptides or depsipeptides). The mechanism is similar in several aspects to polyketide synthesis by modular PKS. NRPSs present a modular organization such that each module comprises the enzymes needed to perform the stepwise addition of one monomer. Therefore, the number of modules corresponds to the number of monomers incorporated, and, most relevant, the order in which the monomers are incorporated reflects the order in which the modules are present on the NRPS. Each module comprises an adenylation domain, responsible for amino acid recognition and activation; a thiolation domain that covalently links the amino acids to a small protein denoted peptidyl carrier protein (PCP); and a condensation domain where the amide bond is formed. Additional specialized domains, such as those for conversion of L- to D-amino acids, may also be present. The steps of the synthesis are as follows: (1) the amino acids are activated by adenylation and each linked, through a thioester bond, to the PCP of the appropriate module; (2) the first amino acid is positioned by PCP at the condensation domain where an amide bond is formed by its carboxyl group with the amino group of the second amino acid, the energy being provided by the breaking of the thioester bond; (3) the formed dipeptide

thioester, carried by PCP to the second condensation domain, forms a peptide bond with the following monomer; and (4) the cycle is repeated until completion of the chain that is then released by a thioesterase. An important example of oligopeptide synthesis is the formation of the tripeptide δ -(L- α -amino adipyl)-L-cysteinyl-D-valine (ACV), the intermediate in the synthesis isopenicillin N, the common precursor in the synthesis of all β -lactam antibiotics. Other examples are the synthesis of daptomycin, a cyclic polypeptide comprising 13 amino acids, and the family of glycopeptides such as vancomycin and teicoplanin whose basic structure is comprised of a polypeptide containing 7 amino acids.

Ribosomal Peptide Synthesis. A group of large peptide antibiotics has been described that are made by the general transcription and translation system of ribosomal protein synthesis (Jack et al. 1997). These are known as the lantibiotics, owing to the presence in their molecules of several lanthionine moieties derived from sulfide bridge formation between cysteine and serine (or threonine) residues. Nisin, an antibiotic used in foods, is produced by unicellular bacteria; others, such as ancovenin, actagardine, and mersacidin, are made by actinomycetes. Analysis of the lantibiotic gene cluster revealed the presence of a gene encoding the synthesis of a large peptide (prepeptide) comprising the sequence of amino acids constituting the backbone of the final molecule and a sequence of amino acids with the characteristic structure of a leader peptide. A second gene is present encoding the enzyme catalyzing the formation of the sulfur bridge typical of lanthionines. The biosynthesis consists of the production of the prepeptide, the formation of lanthionines with the consequent closure of the rings, and the export from the cell with the simultaneous cleavage of the leader peptide. Whereas the genes for the transport system are present in the cluster, the gene responsible for the cleavage can be located elsewhere on the chromosome (Boakes et al. 2009).

Condensation of Carbohydrate Units

A number of important antibiotics are composed of a few carbohydrate molecules, often amino sugars, and one aminocyclitol moiety. These, in spite being formally pseudosaccharides, are generally called aminosaccharide antibiotics. The available evidence indicates that antibiotics having an oligosaccharide structure are formed by the assembly of monomers activated as nucleoside diphosphates at the anomeric carbon (Piepersberg and Distler 1997). In this respect, their biosynthesis is not different from that of the normal polysaccharides present in bacterial cell walls or surfaces. The components of the oligosaccharide antibiotics are most often unusual carbohydrates. Two patterns may be distinguished with regard to their formation: (a) sugars normally found in primary metabolism are assembled and then modified; typical of this pattern is the biosynthesis of the antibiotics of the gentamicin family; and (b) common sugars, such as glucose or glucosamine, are converted (as above discussed in the section Class I Reaction) into unusual carbohydrates and then condensed stepwise to give the final molecule; this is the case of streptomycin biosynthesis. In the latter case, the transformation reactions also

occur, as a rule, on sugars activated as nucleoside diphosphates at the anomeric carbon. However, there is not a rigid distinction between the two cases; both patterns may be present in a single biosynthetic pathway.

These mechanisms of polymerization are similar to those of primary metabolism, which are involved in building molecules that are components of cell envelopes. Polyketide synthesis and, to some extent, nonribosomal polypeptide synthesis appear to be derived from the mechanism of membrane fatty acid biosynthesis, whereas the biosynthesis of sugar-derived antibiotics is similar to that of the polysaccharides present in the external layers of bacterial envelopes, such as the O-antigens of Gram-negative organisms. It is of interest that isoprenoid synthesis, very common in fungal secondary metabolism, is almost absent in biosyntheses of bacterial secondary metabolites.

Class III Reactions. In general, the basic structure produced by a polymerization mechanism, or by condensation of one or more subunits, is further modified by enzymatic reactions to give the final antibiotic molecule (Lancini and Lorenzetti 1993). These “tailoring” reactions are normally very common ones: hydroxylations, double-bond saturations and other reductions, methylations, transaminations, glycosylations, and acylations. However, they are most relevant because the modifications are usually essential for activity. A typical tailoring reaction is the glycosylation of macrolide and glycopeptide antibiotics by many unusual sugars. Tailoring is often responsible for the production, by many strains, of complexes of antibiotic molecules, i.e., structurally related substances quite similar in their biological activity. A complex may arise when an intermediate of the biosynthesis is the substrate of different reactions and therefore yields different products. One example is teicoplanin produced by *A. teichomyceticus*. The antibiotic is a complex of several molecules differing in the structure of the acyl substituents linked to a glucosamine moiety. The relative amounts of the components depend on the amounts of the fatty acids, which are the substrates of the acylation reaction. A typical example of the importance of tailoring is the formation of tetracyclines. Here, the common intermediate methylpretetramide is converted through reductions, amination, and methylation into the final tetracycline molecule. In certain strains, carbon 7 of the molecule is chlorinated, giving rise to chlortetracycline; in contrast, other strains hydroxylate carbon 5, yielding oxytetracycline. Another example is the synthesis of erythromycins: the product of PKS action, deoxyerythronolide B, is first hydroxylated and then glycosylated with two sugars. The resulting molecule can be hydroxylated on the ring, giving erythromycin C, or methylated on one of the sugars, giving erythromycin B, or submitted to both these reactions, giving rise to erythromycin A, thus producing a mixture of the three antibiotics.

Products from Modern Technology

Although industrial microbiology is not a new field, the recombinant DNA discoveries made in 1972 in the laboratories of Stanford

University and the University of California at San Francisco propelled the field to new heights and led to the establishment of a new biotechnology industry in the United States and around the world. The revolutionary exploitation of basic biological discoveries did not take place in a vacuum but heavily depended upon the solid structure of the fermentation industry. Before the new biotechnology era began, there had already been a rapid application of fundamental biological knowledge, thanks to the earlier developments of industrial microbiology. The period from 1910 to 1950 had featured the first large-scale anaerobic fermentations devoted to manufacture of chemicals (acetone and butanol) and the aerobic production of citric acid and then those of penicillin and streptomycin. The scale-up investigations of the penicillin and streptomycin fermentations, a joint effort between Merck & Co., Inc., and Princeton University, gave birth to the new field of biochemical (we prefer microbiological) engineering. On the heels of this major development was the academic development of mutational microbial genetics, which evolved into the new technology of strain improvement. With microbiological engineering and strain improvement at hand, the pharmaceutical industry wasted no time in bringing laboratory discoveries to the commercial scale.

Production of Recombinant Proteins

Modern biotechnology encompasses recombinant DNA technology, enzyme and cell immobilization (“enzyme engineering”), cell fusion, monoclonal antibodies and DNA probes as diagnostics, and in vitro mutagenesis (“protein engineering”). It interacts strongly with industrial microbiology and microbial engineering in areas of fermentation, microbial physiology, high-throughput screening for novel metabolites, automation and miniaturization in screening and strain improvement, bioreactor design, and downstream processing. Biotechnology is having a major effect on health care, diagnostics, and agriculture and promises to make inroads in the practices of other industries such as petroleum, mining, foods, and chemicals. The progress in biotechnology has been truly remarkable. Within 4 years of the development of recombinant DNA technology, genetically engineered bacteria were making human insulin and human growth hormone (hGH). This led to an explosion of investment activity in new companies, mainly dedicated to innovation via genetic approaches. Newer companies entered the scene in various niches such as biochemical engineering and downstream processing. Auxiliary industries also made their mark in the commercial world of biotechnology by offering equipment, supplies, information, mechanisms of communication, and patent protection. In 10 years (1982–1991), seven recombinant pharmaceutical products were approved by FDA and marketed (► [Table 9.1](#)).

In the following years, the number of new products kept growing exponentially. The pharmaceutical market of recombinant proteins in 2005 comprised 134 approved products, with an approximate sales value of 35 billion dollars. The top ten drugs accounted for 26.2 billion dollars. These included Etanercept

■ Table 9.1

Recombinant products marketed in the years 1982–1991

Approval date	Product	Company
1982	Human insulin	Genentech
1985	Human growth hormone	Genentech
1986	Interferon α	Biogen
1986	First recombinant vaccine	Chiron
1987	tPA-plasminogen activator	Genentech
1989	Erythropoietin	Amgen
1991	Granulocyte-CSF	Amgen

(TNF receptor linked to IgG1: 3.6 billion) and four variants of erythropoietin, Aranesp, Procrit, EPOGEN, and NeoRecormon together accounting for 10.8 billion (Lawrence 2006).

Hosts for Recombinant Protein Production

In the early 1980s, *E. coli* was the organism of choice for recombinant protein production. The deep knowledge of the biology and the molecular biology of this bacterium offered a potent set of technologies for the controlled and scalable production of polypeptides of interest. However, it was soon realized that the choice of the producing organism was conditioned by the characteristics of the recombinant product. At the beginning of 2009, among the 151 pharmaceutical recombinant protein marketed, 45 were produced by *E. coli*, 28 by *Saccharomyces cerevisiae*, and 59 by mammalian cells (Ferrer-Miralles et al. 2009). This distribution can be explained by the properties of the hosts in relation to the characteristics of their products.

Escherichia coli

The benefits of *E. coli* as a recombinant host include (1) ease of quickly and precisely modifying the genome, (2) rapid growth, (3) ease of fermentation, (4) growth to very high cell densities, (5) ease of promoter control, (6) ease of alteration of plasmid copy number, (7) ease of formation of intracellular disulfide bonds, (8) accumulation of heterologous proteins up to 50 % of dry cell weight, (9) inexpensive medium ingredients, (10) reproducible performance especially with computer control, and (11) high product yields (Swartz 1996). Not all mammalian polypeptides are produced best in *E. coli*. Heterologous proteins are often produced as inactive insoluble aggregates (inclusion bodies), usually possessing nonnative intra- and intermolecular disulfide bonds and unusual free cysteines. To get active protein, these bodies must be removed from the cell by homogenization, washing, and centrifugation and solubilized by denaturants (guanidine-HCl, urea, and sodium dodecyl sulfate [SDS]), which unfold the protein and (with reducing agents) break the disulfide bonds. Refolding is carried out by removal of denaturant and reducing agent. The renaturation processes are

(1) air oxidation, (2) the glutathione reoxidation system, and (3) the mixed disulfides of protein-S-sulfonate and protein-S-glutathione systems. However, heterologous recombinant proteins can be made in biologically active soluble form at high levels when their genes are fused to the *E. coli* thioredoxin gene (LaVallie et al. 1993). Many murine and human proteins are produced at levels of 5–20 % of total protein as fusions in *E. coli* cytoplasm. (Demain and Vaishnav 2009). However, the major limitation to the use of unicellular bacteria to make eukaryotic recombinant polypeptides is that these organisms lack the ability to make the posttranslational modifications (PTMs) which are present in most eukaryotic proteins. Glycosylation is the most important PTM and is species-, tissue-, and cell-type-specific (Parekh 1989). Almost all eukaryotic cell-excreted polypeptides are glycosylated. In some cases however, a normally glycosylated protein is active without the carbohydrate moiety and can be made in bacteria, as is the case with human tPA (Sarmientos et al. 1989). Most of the 45 approved products of *E. coli* have the following therapeutic indications: infectious diseases (8 products), diseases of the blood (6 products), and endocrine, metabolic, and nutritional diseases (19 products). The anti-infectives include an oral cholera vaccine and several interferon analogs and derivatives. Products against blood diseases include growth factors such as the granulocyte-CSF and interleukin-11. Among the peptides indicated for endocrine and metabolic diseases, there are seven formulations of somatropin and seven of insulin or insulin derivatives. Other important products are calcitonin, tumor necrosis factor alpha, and tPA-plasminogen activator [the complete list of approved recombinant drugs is reported as Addendum 1 in (Ferrer-Miralles et al. 2009)].

Saccharomyces cerevisiae

For a number of years, *S. cerevisiae* was the only yeast used for the industrial production of recombinant proteins. However, other organisms, such as *Pichia pastoris* came upon the scene for production of posttranslation modified proteins. *S. cerevisiae* possesses several properties analogous to those of *E. coli*. Usually, the yeast appears more convenient to use when the target protein is not produced in a soluble form by the prokaryotic system. A few peptides, such as insulin, human growth hormone, and granulocyte-CSF, are produced by both *S. cerevisiae* and *E. coli*, whereas *S. cerevisiae* alone hosts the production of almost all the approved recombinant vaccines (17 products compared to one by *E. coli*) (Ferrer-Miralles et al. 2009).

Mammalian Cell Lines

Microbial organisms in several instances are not suitable for the production of large therapeutic proteins. Most human proteins require, for activity, glycosylation and other posttranslational modifications (PTM) that bacteria are unable to perform correctly. Mammalian cell lines are the best expression systems for these products. Most recombinant proteins belong to the WHO

indications C (neoplasm), D (diseases of the blood), and E (endocrine, nutritional, and metabolic diseases). Almost all are produced by immortalized Chinese hamster ovary (CHO) cell lines. The PTM of this expression system is closely similar to that of human cells. The cells are grown in chemically defined liquid media because excretion of proteins in these media simplifies the purification process. Furthermore, the use of chemically defined media decreases the risk of contamination by prions and viruses. The main drawback of production by mammalian systems is poor secretion. In addition, the costs of production are very high: the construction of an adequate facility may cost over 40 million dollars, and the yearly manufacturing costs are estimated around 20–40 million dollars (Demain and Vaishnav 2009).

Genetic Engineering of Secondary Metabolism

Genetics has had a long history of contributing to the production of bacterial products. The tremendous increases in fermentation productivity and the resulting decreases in costs came about mainly by mutagenesis and screening for higher producing bacterial strains. In the main, this was “brute force” technology, but in recent years, efforts have been devoted to miniaturization and automation of screening procedures and to the development of methods of enhancing the frequency of improved strains by selection procedures (found earlier to be useful in improving production of primary metabolites, e.g., the isolation of antimetabolite-resistant mutants in cases where the natural metabolite is a precursor, an inhibitor, or a corepressor of a biosynthetic pathway). These selective agents include antimetabolites of precursors, 2-deoxyglucose for enzymes and pathways regulated by carbon source regulation, and methylammonium for those regulated by nitrogen source repression. Mutation has served to (1) shift the proportion of metabolites produced in a fermentation broth to a more favorable distribution, (2) elucidate the pathways of secondary metabolism, and (3) yield new compounds. The medically useful products demethyltetracycline and doxorubicin (Adriamycin) were discovered by simple mutation of the cultures producing tetracycline and daunorubicin (daunomycin), respectively. The technique of mutational biosynthesis has been used for the discovery of many new aminoglycoside, macrolide, and anthracycline antibiotics, as well as a commercial antihelminthic agent, doramectin.

Protoplast Fusion

Although mutation was used for forty years to improve antibiotic production, genetic recombination was virtually ignored, the principal reason being the low frequency of recombination, e.g., 10^{-6} . However, application of protoplast fusion changed the situation markedly. Frequencies of recombination increased to even greater than 10^{-1} in some cases, and strain improvement programs routinely incorporate protoplast fusion between different mutant lines. This technique is largely used in industrial laboratories; rarely are the results published but some interesting cases have been reported.

(a) Two cephamycin C-producing species, *Nocardia lactamdurans* and *Streptomyces griseus*, were fused, and among the recombinants were two cultures producing more antibiotic than the best parent (Wesseling and Lago 1981). (b) Protoplast fusion of arginine and cysteine auxotrophs of *S. clavuligerus*, the producer of clavulanic acid, yielded a fusant 30 times more productive than the wild type. (c) Several genetic techniques have been used to improve the productivity of epothilones produced by the myxobacterium *Sorangium cellulosum*. By UV mutation followed by recursive protoplast fusion, yields were increased from 0.8 to 104 mg/L (Gong et al. 2007). (d) Production of spinosad by *Saccharopolyspora spinosa* was also improved by genome shuffling. By mutation with nitrosoguanidine followed by recursive protoplast fusion, a strain was obtained producing over 400 mg/L of the insecticide (Jin et al. 2009).

Use of Genetic Engineering to Improve Productivity or to Produce Modified Antibiotics

Specific gene modifications, based on the knowledge of biosynthetic pathways processes and regulatory mechanisms, have successfully been applied to improve metabolite production or to obtain by fermentation the production of useful semisynthetic metabolites.

(a) Cephamycin C production by *Nocardia lactamdurans* has been improved by overexpression of the *lat* gene (encoding lysine-6-aminotransferase) from strong heterologous promoters (Chary et al. 2000). (b) Overexpression of the positive regulatory gene *ccaR* in *Streptomyces clavuligerus* led to a relevant increase in cephamycin C and clavulanic acid production (Perez-Llarena et al. 1997). (c) Transposition mutagenesis has been successfully used to improve productivity: some *Streptomyces roseosporus* transposition mutants were found producing 50 % more daptomycin than the original strain (Baltz et al. 1997). (d) In *Streptomyces fradiae*, the O-methylation of macrocin is the last step of tylosin synthesis. Transposition insertion of a second *tylF* gene, encoding macrocin O-methyltransferase, increased enzyme production and consequently enhanced the production of tylosin up to 60 %. (e) Epirubicin is a derivative of doxorubicin obtained by chemical replacement of the sugar daunosamine by its isomer 4'-epidaunosamine. A fermentation method was developed to bypass the laborious chemical process. A mutant strain of *Streptomyces peucetius* was constructed, blocked in the *dnmV* gene, essential for the production of daunosamine. By replacing in the chromosome the gene *dnmV* with the heterologous gene *avrE* from *S. avermitilis*, the biosynthesis of the epimeric sugar was obtained and consequently the production of epirubicin by fermentation (Madduri et al. 1998). (f) Epothilones are a complex of four components, produced by the myxobacterium *Sorangium cellulosum*. Epothilone B, one of the components, is a promising anticancer agent under clinical evaluation. The structure of epothilone B comprises a polyketide chain whose biosynthesis initiator molecule is methylmalonyl-CoA, made by

carboxylation of propionyl-CoA. Addition of propionate to the culture medium gave poor results, due to the toxicity of propionic acid. Insertion of the propionyl-CoA synthetase gene (*prpE*) from *Ralstonia solanacearum* resulted in a rapid conversion of propionate into propionyl-CoA and an increase of up to 127–1 in the ratio of epothilone B to epothilone A (Han et al. 2008). (g) In *Streptomyces avermitilis*, gene *aveC* encodes a protein that modulates the production ratio of doramectin (CHC-B1) to other avermectins. Iterative rounds of *aveC* DNA semisynthetic shuffling produced gene variants that were transformed into *S. avermitilis*. Clones were fermented and analyzed to determine the production ratio of CHC-B1 versus other avermectins. The best shuffled gene showed an improved production ratio 23 times over the wild-type gene and was inserted into a high-producing strain, which was developed for industrial use (Stutzman-Engwall et al. 2005).

Combinatorial Biosynthesis

Combinatorial Engineering of Iterative PKS Genes. In a seminal paper, David Hopwood and other known scientists suggested the possibility of obtaining a large number of new antibiotics by combining the genes governing the biosynthesis of antibiotics made by a similar biosynthetic pathway (Hopwood et al. 1985). Attention was initially focused on the aromatic products made by the iterative polyketosynthase (PKS II) of streptomycetes. Cloning of aromatase and cyclase genes from *S. coelicolor* into the 2-hydroxyaklavinone producer, *Streptomyces galilaeus* 31671, yielded the novel hybrid metabolites desoxyerythrolaccin and 1-O-methyl-desoxyerythrolaccin (Strohl et al. 1991). By combining the genes of the synthesis of the octadekide chain of actinorhodin with the aromatase/cyclase genes of tetracenomycin, a new metabolite was obtained. Adding the actinorhodin gene of ketoreductase to the genes of the synthesis of the decaketide chain of tetracenomycin, two different metabolites were produced (McDaniel et al. 1994). On the basis of these and other experiments (McDaniel et al. 1993), general rules were proposed for the rational design of novel aromatic antibiotics by combinatorial biosynthesis (McDaniel et al. 1995). A suitable host, normally *S. coelicolor*, is constructed by deleting the entire cluster of actinorhodin genes. In this strain are inserted the genes of a minimal polyketosynthase (minPKS) comprising the acyltransferase, the ketosynthase (with the cognate chain length factor), and the ACP (acyl carrier protein). The products of these genes perform the synthesis of the polyketide and determine its length and the nature of the starter molecule. Addition of genes encoding cyclases/aromatases or ketoreductase from different organisms leads to the synthesis of a number of diverse molecules. Relevant has been the use of the *whiE* minimal PKS as a platform for engineering the production of a larger number of polyketides. The *whiE* cluster encodes the production of a dodecaketide spore pigment. When minimal *whiE* PKS alone was introduced into a suitable host strain, a dozen polyketides were produced, four of which

were purified and their structure elucidated. By addition of *act* ketoreductase, seven other products were identified. Two novel dodecaketides were produced by adding the *whiE* cyclase/aromatase to the minimal PKS (Yu et al. 1998). Another variation allowed the production of novel anthraquinone antibiotics with initiator molecules different from acetate (Tang et al. 2004). Later, some cases were reported of extension of the combinatorial biosynthesis scope by addition of heterologous sugars to anthracycline aglycones [for a review, see (Olano et al. 2010)]. An interesting example is the generation of ellermycin analogs by combining PKS anthraquinone biosynthesis genes with oleandomycin sugar biosynthetic genes (Rodriguez et al. 2000).

Genetic Engineering of Modular Polyketide Synthases (PKS I). The complexity of modular PKSs presents many more possibilities of introducing gene modifications leading to the biosynthesis of novel metabolites. These are the following: (1) altering chain length, (2) changing AT specificity, (3) modulating the extent of reduction, and (4) changing starter units. By combining multiple changes, an impressive number of novel metabolite can be obtained (Donadio and Sosio 2003). In all the examples, the modifications are made on the 6-deoxyerythronolide B synthase (DEBS), which produces the first intermediate in the biosynthesis of erythromycin (6DEBS). The synthase is composed by six elongation modules, each adding a ketide unit, plus the module loading the starter unit. (1) *Alteration of Chain Length.* The last module of DEBS carries at the carboxyl terminus a thioesterase domain (TA), which releases the polyketide chain, forming the macrolactone. Repositioning the TA domain at the end of module 2, a triketide is formed, cyclized in a six-membered lactone (Cortes et al. 1995). By repositioning TA at the end of module 3, a tetraketide is formed that can cyclize in two ways, forming two different six-membered lactones (Kao et al. 1995). (2) *Changing AT Specificity.* The acyltransferase of all the DEBS modules recognizes methyl malonate as the extender unit. Therefore, on the 6DEBS chain, six methyl substituents are present. The AT domain of module 2 of rapamycin synthase, a malonate-specific domain, was used to replace the methylmalonyl domains of DEBS modules 2, 5, and 6. The result, as expected was the production of 6DEBs lacking the methyl group at positions 10, 4, and 2, respectively (McDaniel et al. 1999). (3) *Modulating the Extent of Reduction.* The ketoreductase domains were deleted from DEBS modules 5 and 6 by site-directed mutagenesis. The expected 6DEBS analogs were produced that carried a keto group at positions 5 and 3, respectively (Donadio et al. 1993; McDaniel et al. 1999). The enoylreductase domain from module 4 was inactivated by site-directed mutagenesis, resulting in the formation of the 6-7-unsaturated analog of 6DEBS (Donadio et al. 1993). (4) *Changing Starter Units.* The AT-ACP segment from the avermectin PKS loading module, which incorporates branched-chain isomers of butyric acid, was used to replace the loading module from DEBS. Two macrolactones were produced derived from isobutyrate and 2-methylbutyrate starters (Marsden et al. 1998).

Multiple Genetic Modifications. A combinatorial library of polyketides was constructed starting from 6-DEB synthase. This was accomplished by substituting the AT domains and the processing domains KR, DH, and ER of DEBS modules by counterparts from the rapamycin PKS that encode alternative substrate specificity and reducing activities. The engineered DEBS obtained contained single, double, and triple modifications and generated the corresponding modified macrolactones. Over 50 analogs of erythromycin's lactone were produced and identified (McDaniel et al. 1999). Several PKS have been formed by a different approach consisting of combining, rather than single domains or modules, large protein subunits from different modular PKS. Different combinations of subunits of picromycin, erythromycin, and oleandomycin were cloned and expressed in *S. lividans* generating a series of hybrid polyketides (Tang et al. 2000). Later, an innovative system was devised by scientists of Kosan Biosciences, allowing the production and screening of a multitude of desired polyketides. From eight PKS clusters, 14 modules were synthesized and were associated in 145 bimodular combinations, spanning over 1.5 million bp of novel PKS gene sequences. Inserted and expressed in *E. coli*, nearly half of the combinations mediated the synthesis of the predicted polypeptide (Menzella et al. 2005).

Combinatorial Biosynthesis of Polypeptide Antibiotics

Most peptide antibiotics are biosynthesized by the nonribosomal peptide synthetase (NRPS), a large protein that, in its modular organization, is similar to the modular PKSs. In fact, some concepts of combinatorial synthesis of PKSs, such as changing the recognition specificity of a module, or altering the order of the modules and consequently the amino acid sequence, can be applied. To demonstrate this, genes encoding the activating domains for phenylalanine, ornithine and leucine from the gramicidin NRPS and cysteine and valine from the penicillin ACV, were transferred into a mutant of the surfactin producer *B. subtilis* which had a disrupted *leu7* gene. The five new surfactins produced substantially maintained the biological properties of the natural product (Stachelhaus et al. 1995). In further experiments, the leucine-activating module was exchanged within the first three modules of the surfactin NRPS. The results demonstrated that a minimal module (composed by the activation domain and the thiolation domain) can confer its amino acid specificity on a multimodular peptide synthetase (Schneider et al. 1998). Considerable effort has been made by Cubist Pharmaceuticals scientist to produce recombinant analogs of the antibiotic daptomycin. A complex *trans*-complementation system was set up in *Streptomyces roseosporus* to generate subunit exchanges of the daptomycin NRPS with subunits of the synthetases of the structurally related daptomycin antibiotic A54145 and calcium-dependent antibiotic. The recombinant proteins produced several novel hybrid molecules. Additional novel derivatives of daptomycin were obtained by module exchange at positions D-Ala₈ and D-Ser₁₁. Most of the

compounds displayed antibacterial activities (Baltz et al. 2006). Recently, an alternative similar system was constructed using the NRPS of the structurally related lipopeptide A54145 in its natural host *Streptomyces fradiae*. Hybrid synthetase biosynthetic genes were generated and expressed in combination with a deletion of the methyltransferase gene involved in the formation of 3-methylglutamic acid. Some of the compounds were very active against *S. aureus* and other Gram-positive pathogens, and one had some curative effect in a *Streptococcus pneumoniae* experimental infection (Nguyen et al. 2010).

Closing Remarks

The antibiotics produced by bacteria have been useful in our battles against infectious bacteria and fungi for over 60 years. In addition, many antibiotics are used commercially or are potentially useful in medicine for activities other than their antibiotic action. There has been a major change in the field of discovery and application of secondary metabolites over the past 20 years. This change is characterized by the broadening of the scope of the search. No longer are bacterial sources looked upon solely as potential solutions for microbial diseases. This change in screening philosophy has been followed by ingenious applications of molecular biology to detect receptor antagonists and agonists and other agents inhibiting or enhancing cellular activities on a molecular level (Tanaka and Omura 1997).

Secondary metabolites are employed as antitumor agents, immunosuppressive agents, enzyme inhibitors, antiparasitic agents, etc. Many of these products were first discovered as antibiotics that failed in their commercial development as such, although a few successful secondary metabolites appear to have no antibiotic activity. The recently increased development of resistance to older antibacterial and antifungal drugs is being met with the use or clinical testing of older underutilized or previously nondeveloped narrow-spectrum antibacterial products.

Natural products have been an overwhelming success in our society. The doubling of our life span in the twentieth century is mainly due to the use of plant and microbial secondary metabolites (Verdine 1996). They have reduced pain and suffering and revolutionized medicine by allowing for the transplantation of organs. Natural products are the most important anticancer and anti-infective agents. Over 60 % of approved and pre-NDA (new drug application) candidates are natural products or related to them, not including biologicals such as vaccines and monoclonal antibodies (Cragg et al. 1997; Newman and Cragg 2007). Almost half of the best-selling pharmaceuticals are natural or are related to natural products. Often, the natural molecule was not used itself but served as a lead molecule for manipulation by chemical or genetic means.

Secondary metabolism has evolved in nature in response to needs and challenges of the natural environment. Nature is continually carrying out its own version of combinatorial chemistry (Verdine 1996). Bacteria have inhabited the earth for over 3 billion years (Holland 1998). During that time, there has been an evolutionary process going on in which producers of secondary

metabolites have evolved according to their local environments. When the metabolites were useful to the organism, the biosynthetic genes were retained, and genetic modifications further improved the process. Combinatorial chemistry practiced by nature is much more sophisticated than combinatorial chemistry in the laboratory, yielding exotic structures rich in stereochemistry, concatenated rings, and reactive functional groups (Verdine 1996; Baltz et al. 2006). We hear today that combinatorial chemistry will replace natural product efforts for discovery of new drugs. Some companies are even dropping their natural product programs to support combinatorial chemistry efforts. This makes no sense considering that the role of combinatorial chemistry, like those of structure-function drug design and recombinant DNA technology two and three decades ago, is that of complementing and assisting natural product discovery and development, not replacing them. Natural product research is at its highest level (Imada 2004), owing to unmet needs, remarkable diversity of structures and activities, utility as biochemical probes, novel and sensitive assay methods, improvements in isolation, purification and characterization, and new production methods (Clark 1996). Enormous diversity exists in secondary metabolism, as illustrated by the following example: 10,000 polyketides are known, many of which are produced by bacteria (Rawls 1998). These include antibiotics, antitumor agents, immunosuppressants, antiparasitic agents, antifungals, and agricultural products. Many new polyketides have been made by genetic methods involving modification or exchange of polyketide genes between organisms to create hybrid polyketides, i.e., by combinatorial biosynthesis (Hutchinson 1997; McAlpine 1998; Baltz et al. 2006; Donadio and Sosio 2003). We should also keep in mind the enormous diversity of bacteria and that only a minor proportion have thus far been examined for secondary metabolite production. It has been estimated that 1 g of soil contains 1,000–10,000 species of undiscovered prokaryotes (Torsvik et al. 1996). In addition, surprisingly, it has been found that well-known actinomycetes (either producing or not producing polypeptide antibiotics) harbor an unsuspected number of gene clusters coding for polypeptide synthases (Sosio et al. 2000). It is conceivable that these could be activated to produce novel metabolites. The main factors important for the discovery of useful compounds in the future are commitment, ingenuity, and the ability to exploit nature's biodiversity and to devise simple in vitro high-throughput screening procedures for desirable activities.

Genetic engineering and its associated disciplines, as first developed in bacteria, have already made major impacts in the world of medicine and finance and are changing the face of agriculture and industry today and will continue to do so. Bacteria have been employed to produce many mammalian polypeptides as pharmaceuticals of major importance to modern medicine (Demain and Vaishnav 2009). The improvement of secondary metabolite production processes and the discovery of new drugs (by combinatorial biosynthesis) can be attributed to the remarkable developments of recombinant DNA technology (Ferrer-Miralles et al. 2009).

Molecular biology of bacteria led the way for the development of the biotechnology industry, and today, molecular biology is the major driving force in pharmaceutical research (Ferrer-Miralles et al. 2009). In addition to natural polypeptides, analogs can be produced by recombinant DNA technology. Second-generation recombinant polypeptides include modifications of first-generation products to alter specificity of targets, distribution in tissues, pharmacokinetics, side effects, and stability (Huber 1989). Third-generation peptides will fuse coding sequences of different genes, e.g., an enzyme's catalytic sequence to a cell-specific receptor-binding sequence, to achieve targeted drug delivery. In the future, we shall see the replacement of polypeptide drugs by small molecules (Moore 1992) produced by chemical synthesis or by bacteria. Protein drugs are difficult to use because delivery systems are often inappropriate. They cannot be orally administered because they are enzymatically degraded in the stomach. Market size is limited by the need for injection. Polypeptides generally have to be administered by intravenous injection of hospitalized patients. Low molecular mass drugs might be given by intradermal, intraperitoneal, or oral route and will probably be more stable and nonimmunogenic. Because bacteria are such excellent producers of small peptides, we can expect full use of these prokaryotes as means of production of these pharmaceuticals of the future.

References

- Baltz RH, MacHenney MA, Cantwell CA, Queener SW, Solemberg PJ (1997) Application of transposition mutagenesis in antibiotic producing streptomycetes. *Ant v Leeuwenhoek* 71:179–187
- Baltz RH, Brian P, Miao V, Wrigley SK (2006) Combinatorial biosynthesis of lipopeptide antibiotics in *Streptomyces roseosporus*. *J Ind Microbiol Biotechnol* 33:66–67
- Barriere JC, Berthaud N, Beyer D, Dutka-Malen S, Paris JM, Desnottes JF (1998) Recent developments in streptogramin research. *Curr Pharm Design* 4:155–180
- Bérty J (2005) Bioactive microbial metabolites. *J Antibiot* 58:1–26
- Bibb M (1996) The regulation on antibiotic production in *Streptomyces coelicolor* A3(2). *Microbiology* 142:1335–1344
- Birnbaum J, Stapley EO, Miller AK, Wallick H, Hendlin D, Woodruff HB (1978) Cefoxitin, a semi-synthetic cephamycin: a microbiological overview. *J Antimicrob Chemother* 4:15–32
- Birnbaum J, Kahan FM, Kropp H, MacDonald JS (1985) Carbapenems, a new class of beta-lactam antibiotics: discovery and development of imipenem/cilastatin. *Am J Med* 78(Suppl 6A):3–21
- Boakes S, Cortés J, Appleyard AN, Rudd BA, Dawson MJ (2009) Organization of the genes encoding the biosynthesis of actagardine and engineering of a variant generation system. *Mol Microb* 72:1126–1136
- Bollag DM, McQueney PA, Zhu J (1995) Epothilones, a new class of microtubule-stabilizing agents with a taxol-like mechanism of action. *Cancer Res* 55:2325–2333
- Borel JF, Feurer C, Gabler HU, Stahelin H (1976) Biological effects of cyclosporin A: a new antilymphocytic agent. *Agents Actions* 6:468–475
- Borghesi A, Coronelli C, Faniuolo F, Allievi G, Pallanza R, Gallo GG (1984) Teichomycins: new antibiotics from *Actinoplanes teichomyceticus*. Separation and characterization of the component teichomycin (teicoplanin). *J Antibiot* 37:615–620
- Breiman R, Butler J, Tenover F, Elliot J, Facklam R (1994) Emergence of drug-resistant pneumococcal infections in the United States. *JAMA* 271:1831–1835
- Brown AG (1986) Clavulanic acid, a novel β -lactamase inhibitor: a case-study in drug discovery and development. *Drug Des Deliv* 1:1–21

- Cavalleri B, Pagani H, Volpe G, Selva E, Parenti F (1984) A-16686, a new antibiotic from *Actinoplane*. I. Fermentation, isolation and preliminary physico-chemical characteristics. *J Antibiot* 37:309–317
- Chary VK, de la Fuente JL, Leitao AL, Liras P, Martin JF (2000) Overexpression of the *lat* gene in *Nocardia lactamdurans* from strong heterologous promoters results in very high levels of lysine6-aminotransferase and up to two-fold increase of cephamycin C production. *Appl Microbiol Biotechnol* 53:282–288
- Chater KF, Bibb MJ (1997) Regulation of bacterial antibiotic production. In: Kleinkauf H, von Döhren H (eds) *Biotechnology*, vol 7. VCH Weinheim, New York, pp 57–105
- Chatterjee S, Chatterjee S, Lads SJ, Phansalkar MS, Rupp RH, Ganguli BN, Fehlhaber HW, Kogler H (1992) Mersacidin a new antibiotic from *Bacillus*. Fermentation, isolation, purification and chemical characterization. *J Antibiot* 45:832–838
- Chen T, Arison B, Gullo V, Inamine E (1989) Further studies on the biosynthesis of the avermectins. *J Ind Microbiol* 4:231–238
- Clark AM (1996) Natural products as a resource for new drugs. *Pharmaceut Res* 13:1133–1141
- Coronelli C, White RJ, Lancini GC, Parenti F (1975) Lipiarmycin, a new antibiotic from *Actinoplane*. II. Isolation, chemical, biological and biochemical characterization. *J Antibiot* 28:253–259
- Coronelli C, Tamoni G, Lancini GC (1976) Gardimycin, a new antibiotic from *Actinoplanes*. II. Isolation and preliminary characterization. *J Antibiot* 29:507–510
- Cortes J, Wiesmann KE, Roberts GA, Brown MJ, Stauton J, Leadlay PF (1995) Repositioning of a domain in a modular polyketide synthase to promote specific chain cleavage. *Science* 268:1487–1489
- Cragg GM, Newman DJ, Snader KM (1997) Natural products in drug discovery and development. *J Nat Prod* 60:52–60
- Dansey JE (2006) Therapeutic targets: MTOR and related pathways. *Cancer Biol Ther* 5:1065–1075
- Debono M, Abbott BJ, Molloy RM, Fukuda DS, Hunt AH, Daupert VM, Counter FT, Ott JL, Carrell CB, Howard LC, Boeck LD, Hamill RL (1988) Enzymatic and chemical modifications of lipopeptide antibiotic L21978; the synthesis and evaluation of daptomycin (LY1146032). *J Antibiot* 41:1093–1105
- Demain AL (1983) New applications of microbial products. *Science* 219:709–714
- Demain AL (1989) Function of secondary metabolites. In: Hershberger CL, Queener SW, Hegeman G (eds) *Genetics and molecular biology of industrial microorganisms*. ASM Press, Washington, DC, pp 1–11
- Demain AL, Vaishnav P (2009) Production of recombinant proteins by microbes and higher organisms. *Biotechnol Adv* 27:297–306
- DiMasi J, Seibring M, Lasagna L (1994) New drug development in the United States from 1963 to 1992. *Clin Pharmacol Ther* 55:609–622
- Donadio S, Sosio M (2003) Strategies for combinatorial biosynthesis with modular polyketide synthases. *Comb Chem High Throughput Screen* 6:489–500
- Donadio S, Staver MJ, McAlpine JB, Swanson SJ, Katz L (1991) Modular organization of genes required for complex polyketide biosynthesis. *Science* 252:675–679
- Donadio S, McAlpine JB, Sheldon PA, Jackson MA, Katz L (1993) An erythromycin analog produced by reprogramming of polyketide synthesis. *Proc Natl Acad Sci USA* 90:7119–7123
- Dutton C, Gibson S, Goudie A, Holdom K, Pacey M, Ruddock J (1991) Novel avermectins produced by mutational biosynthesis. *J Antibiot* 44:357–365
- Ensign JC (1992) Introduction to actinomycetes. In: Balows A, Truper HG, Dworkin M, Harder W, Schleifer KE (eds) *The prokaryotes*, vol 1, 2nd edn. Springer, Berlin, pp 811–815
- Ferrer-Miralles N, Domingo-Espin J, Corcero JL, Vasquez E, Villaverde A (2009) Microbial factories for recombinant pharmaceuticals. *Microb Cell Fact* 8:17–25
- Fleming ID, Nisbet LJ, Brewer SJ (1982) Target directed antimicrobial screens. In: Bullock JD, Nisbet LJ, Winstanley DJ (eds) *Bioactive microbial products: search and discovery*. Academic, London, pp 107–130
- Giles FJ (2002) Gentuzumab ozogamicin: promise and challenge in patients with acute myeloid leukemia. *Expert Rev Anticancer Ther* 2:630–640
- Goldman DA, Weinstein RA, Wenzel RP, Tablan OC, Duma RJ, Gaynes RP, Schlosser J, Martone WJ (1996) Strategies to prevent and control the emergence and spread of antimicrobial-resistant microorganisms in hospitals. *JAMA* 275:234–240
- Gong GL, Sun X, Liu XL, Hu W, Cao WR, Liu H (2007) Mutation and high-throughput screening for improving the production of epothilones of *Sorangium*. *J Ind Microbiol Biotechnol* 34:615–623
- Goodin S, Kane MP, Rubin EH (2004) Epothilones: mechanism of action and biological activity. *J Clin Oncol* 22:2015–2225
- Goudie AC, Evans NA, Gratton KAF, Bishop BF, Gibson SP, Holdom KS, Kaye B, Wicks RS, Lewis D, Weatherley AJ, Bruce CI, Herbert A, Seymour DJ (1993) Doramectin—a potent novel endectocide. *Vet Parasitol* 49:5–15
- Hafner EW, Holley BW, Holdom KS, Lee E, Wax RG, Beck D, McArthur H, Wernau WC (1991) Branched-chain fatty acid requirement for avermectin production by a mutant of *Streptomyces avermitilis* lacking branched-chain 2-oxo acid dehydrogenase activity. *J Antibiot* 44:349–356
- Han SJ, Park SW, Park BW, Sim SJ (2008) Selective production of epothilone B by heterologous expression of propionyl-CoA synthetase in *Sorangium cellulosum*. *J Microbiol Biotechnol* 18:135–137
- Haney ME Jr, Hoehn MM (1968) Monensin, a new biologically active compound. I: discovery and isolation. *Antimicrob Agents Chemother* 7:349–352
- Hendlin D, Stapley EO, Jackson M, Wallick H, Miller AK, Wolf FJ, Miller T, Chalet L, Kahan FM, Foltz EL, Woodruff HB, Mata JM, Hernandez S, Mochales S (1969) Phosphonomycin: a new antibiotic produced by strains of *Streptomyces*. *Science* 166:122–123
- Hesketh A, Chen WJ, Ryding J, Chang S, Bibb M (2007) The global role of ppGpp synthesis in morphological differentiation and antibiotic production in *Streptomyces coelicolor* A3(2). *Genome Biol* 8:R161
- Higgins DL, Chang R, Debobov DV, Leung J, Wu T, Krause KM, Sandvik E, Hubbard JM et al (2005) Telavancin, a multifunctional glycopeptide, disrupts both cell wall synthesis and cell membrane integrity in methicillin-resistant *Staphylococcus aureus*. *Antimicrob Ag Chemother* 49:1127–1134
- Holland HD (1998) Evidence for life on earth more than 3850 million years ago. *Science* 275:38–39
- Hopwood DA, Sherman DH (1990) Molecular genetics of polyketides and comparison with fatty acid biosynthesis. *Annu Rev Genet* 24:37–66
- Hopwood DA, Malpartida F, Kieser HM, Ikeda H, Duncan J, Fujui I, Rudd BAM, Floss HG, Omura S (1985) Production of “hybrid” antibiotics by genetic engineering. *Nature* 314:642–644
- Horinouchi S (2003) AfsR an integrator of signals that are sensed by multiple serine/threonine kinases in *Streptomyces coelicolor* A3(2). *J Ind Microbiol Biotechnol* 30:462–467
- Huang S, Bjornsti MA, Houghton PJ (2003) Rapamycins; mechanism of action and cellular resistance. *Cancer Biol Ther* 2:222–232
- Huber BE (1989) Therapeutic opportunities involving cellular oncogenes: novel approaches fostered by biotechnology. *FASEB J* 3:5–13
- Hudes GR (2009) Targeting mTOR in renal cell carcinoma. *Cancer* 115(10 Suppl):2313–2320
- Hutchinson CR (1997) Antibiotics from genetically engineered microorganisms. In: Strohl W (ed) *Biotechnology of antibiotics*, 2nd edn. Marcel Dekker, New York, pp 683–702
- Ikeda H, Omura S (1997) Avermectin biosynthesis. *Chem Rev* 97:2591–2609
- Imada C (2004) Enzyme inhibitors of marine microbial origin with pharmaceutical importance. *Mar Biotechnol* (NY) 6:193–198
- Izumida H, Adachi K, Mihara A, Yasuzawa T, Sano H (1997) Hydroxyakalone, a novel xanthine oxidase inhibitor produced by a marine bacterium, *Agrobacterium aurantiacum*. *J Antibiot* 50:916–918
- Jack R, Gotz F, Jung G (1997) Lantibiotics. In: Kleinkauf H, von Döhren H (eds) *Biotechnology*, vol 7. VCH Weinheim, New York, pp 323–370
- Jin ZH, Xu B, Lin SZ, Jin QC, Chen PL (2009) Enhanced production of spinosad in *Saccharopolyspora spinosa* by genome shuffling. *Appl Biochem Biotechnol* 159:655–663
- Kahan JS, Kahan FM, Geogelman R, Currie SA, Jackson M, Stapley EO, Miller TW, Hendlin D, Mochales S, Hernandez S, Woodruff HB, Birnbaum J (1979) Thienamycin, a new β -lactam antibiotic: discovery, taxonomy, isolation, and physical properties. *J Antibiot* 32:1–12
- Kao CM, Luo G, Katz L, Cane DE, Khosla C (1995) Manipulation of macrolide ring size by directed mutagenesis of a modular polyketide synthase. *J Am Chem Soc* 117:9105–9106

- Kato JY, Miyahisa I, Mashiko M, Ohnishi Y, Horinouchi S (2004) A single target is sufficient to account for the biological effects of the A-factor receptor protein of *Streptomyces griseus*. *J Bacteriol* 186:2206–2211
- Katz L, Donadio S (1993) Polyketide synthesis: prospects for hybrid antibiotics. *Ann Rev Microbiol* 47:875–912
- Kino T, Hatanaka H, Hashimoto M, Nishiyama M, Goto T, Okuhara M, Kohsaka M, Aoki H, Imanaka H (1987) FK-506, a novel immunosuppressant isolated from *Streptomyces*. 1: fermentation, isolation and physico-chemical and biological characteristics. *J Antibiot* 40:1249–1255
- Kirst HA (2010) The spinosyn family of insecticides: realizing the potential of natural product research. *J Antibiot* 63:101–111
- Kirst HA, Michel KH, Martin JW, Creemer LC, Chio EH, Yao RC, Nakatsukasa WM, Boeck L, Oocolowitz JL, Paschal JW, Deeter JB, Jones ND, Thompson GD (1991) A83543A-D, unique fermentation-derived tetracyclic macrolides. *Tetrahedron Lett* 32:4839–4842
- Kleinkauf H, von Döhren H (1987) Biosynthesis of peptide antibiotics. *Ann Rev Microbiol* 41:259–289
- Lancini GC (2006) Forty years of antibiotic research at Lepetit: a personal journey. *SIM News* 56:192–212
- Lancini GC, Demain AL (1999) Secondary metabolism in bacteria: antibiotic pathways, regulation, and function. In: Lengeler JW, Drews G, Schlegel HG (eds) *Biology of the prokaryotes*. Thieme Verlag, Stuttgart, pp 627–651
- Lancini GC, Lorenzetti R (1993) *Biotechnology of antibiotics and other bioactive microbial metabolites*. Plenum Press, New York, pp 95–132
- Lancini GC, Parenti F, Gallo GG (1995) *Antibiotics: a multidisciplinary approach*. Plenum Press, New York
- LaVallie ER, DiBlasio EA, Kovacic S, Grant KL, Schendel PF, McCoy JM (1993) A thioredoxin gene fusion expression system that circumvents inclusion body formation in the *E. coli* cytoplasm. *Bio/Technology* 11:187–193
- Lawrence S (2006) Biotech blockbusters consolidate markets. *Nat Biotechnol* 24:1466
- Lazzarini A, Cavaletti L, Toppo G, Marinelli F (2001) Potentialities of rare actinomycetes as producers of new antibiotics. *Ant v Leeuwenhoek* 79:399–405
- Little PS, Peddie BA (1978) Clinical use of cefoxitin, a new semisynthetic cephamycin. *N Z Med J* 88:46–49
- Liu J, Farmer J, Lane W, Friedman J, Waissman I, Schreiber S (1991) Calcineurin is a common target of cyclophilin-cyclosporin A and FKBP-FK506 complexes. *Cell* 66:807–815
- Madduri K, Kennedy J, Rivola G, Inventa-Solari A, Filippini S, Zanuso G, Colombo AL, Gewain KM, Occi JL, MacNeil DJ, Hutchinson CR (1998) Production of the antitumor drug epirubicin (4' epidoxorubicin) and its precursor by a genetically engineered strain of *Streptomyces peucetius*. *Nat Biotechnol* 16:69–74
- Marsden AF, Wilkinson B, Cortès J, Dunster NJ, Stauton J, Leadlay PF (1998) Engineering broader specificity into an antibiotic-producing polyketide synthase. *Science* 279:199–202
- Martin JF (2004) Phosphate control of the biosynthesis of antibiotics and other secondary metabolites is mediated by the PhoR-PhoP system: an unfinished story. *J Bacteriol* 186:5197–5201
- McAlpine J (1998) Unnatural natural products by genetic manipulation. In: Sapienza DM, Savage LM (eds) *Natural products II: new technologies to increase efficiency and speed*. International Business Community, Southborough, MA, pp 251–278
- McArthur HIA (1998) The novel avermectin, doramectin – a successful application of mutasynthesis. In: Hutchinson CR, McAlpine J (eds) *Proceedings, biotechnology of microbial products conference, (BMP 97), Society for Industrial Microbiology, Fairfax, VA, pp 43–48*
- McDaniel R, Ebert-Khosla S, Hopwood DA, Khosla C (1993) Engineered biosynthesis of novel polyketides. *Science* 262:1546–1550
- McDaniel R, Ebert Khosla S, Hopwood DA, Khosla C (1994) Engineered biosynthesis of novel polyketides: actVII and actIV genes encode aromatase and cyclase enzymes, respectively. *J Am Chem Soc* 116:10855–10859
- McDaniel R, Ebert Khosla S, Hopwood DA, Khosla C (1995) Rational design of aromatic polyketide natural products by recombinant assembly of enzymatic subunits. *Nature* 375:549–554
- McDaniel R, Thamehaipenet A, Gustafsson C, Fu H, Betlach M, Ashley G (1999) Multiple genetic modifications of the erythromycin polyketide synthase to produce a library of novel natural products. *Proc Natl Acad Sci USA* 96:1846–1851
- Mendez C, Brana AF, Manzanal MB, Hardisson C (1985) Role of substrate mycelium in colony development in *Streptomyces*. *Can J Microbiol* 31:446–450
- Menzella HG, Reid R, Carney JR, Chandran SS, Reisinger SJ, Patel KG, Hopwood DA, Santi DV (2005) Combinatorial polyketide biosynthesis by *de novo* design and rearrangement of modular polyketide synthase genes. *Nat Biotechnol* 21:1171–1176
- Minotti G, Menna P, Salvatorelli E, Cairo G, Gianni L (2004) Anthracyclines: molecular advances and pharmacologic developments in antitumor activity and cardiotoxicity. *Pharmacol Rev* 56:185–229
- Moore M (1992) Strategic alliances: technological value in pharmaceutical drug discovery. *Biofut Eur* 9:138–143
- Morris A, Kellner JD, Low DE (1998) The superbugs: evolution, dissemination and fitness. *Curr Opin Microbiol* 1:524–529
- Newman DJ, Cragg GM (2007) Natural products as sources of new drugs over the last 25 years. *J Nat Prod* 70:461–477
- Nguyen KT, He X, Alexander DC, Li C, Gu JQ, Mascio C, Van Praag A, Morti L, Chu M, Silverman JA, Brian P, Baltz RH (2010) Genetically engineered lipopeptide antibiotics related to A54145 and daptomycin with improved properties. *Antimicrob Agents Chemother* 54:1404–1413
- Nichterlein T, Kretschmar M, Hof H (1996) RP 59500, a streptogramin derivative, is effective in murine listeriosis. *J Chemother* 8:107–112
- Ogawara D, Fukuda M, Nakamura Y, Kono S (2010) Efficacy and safety of amrubicin hydrochloride for treatment of relapsed small cell lung cancer. *Cancer Manag Res* 2:191–195
- Olano C, Mendez C, Salas JA (2010) Post-PKS tailoring steps in natural product-producing actinomycetes from the perspective of combinatorial biosynthesis. *Nat Prod Rep* 27:571–616
- Pallanza R, Berti M, Goldstein BP, Mapelli E, Randisi E, Scotti R, Arioli V (1983) Teichomycin: in -vitro and in-vivo evaluation in comparison with other antibiotics. *J Antimicrob Chemother* 11:419–425
- Parekh R (1989) Polypeptide glycosylation and biotechnology. *Biotech Eur* 6:18–21
- Parenti F, Schito GC, Courvalin P (2000) Teicoplanin chemistry and microbiology. *J Chemother* 12(Suppl 5):5–14
- Perez-Llarena FG, Liras P, Rodriguez-Garcia A, Martin JF (1997) A regulatory gene (*ccaR*) required for cephamycin and clavulanic acid production in *Streptomyces clavuligerus*: amplification results in overproduction of both β -lactam compounds. *J Bacteriol* 179:2053–2059
- Piepersberg W, Distler J (1997) Aminoglycosides and sugar components in other secondary metabolites. In: Kleinkauf H, von Döhren H (eds) *Biotechnology, vol 7*. VCH Weinheim, New York, pp 397–488
- Rawls RL (1998) Polyketides: research increases on modular synthesis of these biomolecules by enzymes. *Chem Eng News* 76:29–30
- Rodriguez L, Oelkers C, Aguirrezabalaga I, Brana AF, Rhor J, Mendez C, Salas JA (2000) Generation of hybrid elloramycin analogs by combinatorial biosynthesis using genes from anthracycline-type and macrolide biosynthetic pathways. *J Mol Microbiol Biotechnol* 2:271–276
- Sarmientos P, Duchesne M, Deneffe P, Bolziau J, Fromage N, Delporte N et al (1989) Synthesis and purification of active human tissue plasminogen activator from *Escherichia coli*. *Bio/Technology* 127:495–501
- Scheinfeld N (2004) Telithromycin: a brief review of a new ketolide antibiotic. *J Drugs Dermatol* 3:409–413
- Schneider A, Stachelhaus T, Marahiel MA (1998) Targeted alteration of the substrate specificity of peptide synthetases by rational module swapping. *Mol Gen Genet* 257:308–318
- Sola-Landa A, Moura RS, Martin JF (2003) The two component PhoR-PhoP system controls both primary metabolism and secondary metabolite biosynthesis in *Streptomyces lividans*. *Proc Natl Acad Sci USA* 100: 6133–6138
- Sosio M, Bossi E, Bianchi A, Donadio S (2000) Multiple gene synthetase gene clusters in actinomycetes. *Mol Gen Genet* 264:213–221
- Stachelhaus T, Schneider A, Marahiel M (1995) Rational design of peptide antibiotics by targeted replacement of bacterial and fungal domains. *Science* 269:69–72

- Stapley EO (1982) Avermectins, antiparasitic lactones produced by *Streptomyces avermitilis* isolated from a soil in Japan. In: Umezawa H, Demain AL, Hata R, Hutchinson CR (eds) Trends in antibiotic research. Antibiotic Research Association, Tokyo, pp 154–170
- Stephens C, Shapiro L (1997) Bacterial protein secretion – a target for new antibiotics? *Chem Biol* 4:637–641
- Stinson SC (1996) Drug firms restock antibacterial arsenal. *Chem Eng News* 74:75–100
- Strohl WR (1997) Biotechnology of antibiotics, 2nd edn. Marcel Dekker, New York
- Strohl WR, Bartel PL, Li Y, Connor NC, Woodman RH (1991) Expression of polyketide biosynthesis and regulatory genes in heterologous streptomycetes. *J Ind Microbiol* 7:163–174
- Strohl WR, Woodruff RL, Monaghan D, Hendlin H, Mochales S, Demain AL, Liesch L (2001) The history of natural products research at Merck and Co., Inc. *SIM News* 51:5–19
- Stutzman-Engwall H, Colon S, Fedechko R, McArthur H, Pekrun K, Chen Y, Jenne S, La C, Thrin N, Kim S, Zang XY, Fox R, Gustafsson C, Krebber A (2005) Semi-synthetic DNA shuffling of *aveC* leads to improved industrial scale production of doramectin by *Streptomyces avermitilis*. *Metab Eng* 7:27–37
- Sum PE (2006) Case studies in current drug development: “glycylcyclines”. *Curr Opin Chem Biol* 10:374–379
- Sum PE, Sum FW, Projan SJ (1998) Recent developments in tetracycline antibiotics. *Curr Pharm Des* 4:119–132
- Swartz JR (1996) *Escherichia coli* recombinant DNA technology. In: Neidhardt FC (ed) *Escherichia coli* and *Salmonella*: cellular and molecular biology, 2nd edn. American Society of Microbiology Press, Washington, DC, pp 1693–1711
- Takano E (2006) Gamma-butyrolactones: *Streptomyces* signalling molecules regulating antibiotic production and differentiation. *Curr Opin Microbiol* 9:287–294
- Tanaka H, Omura S (1997) Screening of novel receptor-active compounds of microbial origin. In: Rehm HJ, Reed G, Kleinkauf H, von Döhren H (eds) *Biotechnology*, vol 7, 2nd edn. VCH Weinheim, New York, pp 107–132
- Tang L, Fu H, McDaniel R (2000) Formation of functional heterologous complexes using subunits from the picromycin, erythromycin and oleandomycin polyketide synthases. *Chem Biol* 7:77–84
- Tang Y, Lee TS, Khosla C (2004) Engineered biosynthesis of regioselectively modified aromatic polyketides using bimodular polyketide synthases. *PLoS Biol* 2:0228–0238
- Tenover FC, Hughes JM (1996) The challenges of emerging infectious diseases. *JAMA* 275:300–304
- Thompson GD, Dutton R, Sparks TC (2000) Spinosad—a case study: an example from a natural products discovery program. *Pest Manag Sci* 56:696–702
- Tomasz M (1995) Mitomycin C: small, fast and deadly (but very selective). *Curr Biol* 2:575–579
- Torsvik V, Sorheim R, Goksoyr J (1996) Total bacterial diversity in soil and sediment communities – a review. *J Indust Microbiol* 17:170–178
- Truscheit E, Frommer W, Junge B, Müller L, Schmidt D, Wingender W (1981) Chemistry and biochemistry of microbial α -glucosidase inhibitors. *Angew Chemie Internat Ed* 20:744–761
- Umezawa H (1972) Enzyme inhibitors of microbial origin. University Park Press, Baltimore
- Umezawa H (1982) Low molecular-weight inhibitors of microbial origin. *Ann Rev Microbiol* 36:75–99
- Umezawa H, Maeda K, Takeuci T, Okami Y (1966) New antibiotics, bleomycin A and B. *J Antibiot* 19:200–209
- Verdine GL (1996) The combinatorial chemistry of nature. *Nature* 384(Suppl):11–13
- Vežina C, Kudelski A, Sehgal SN (1975) Rapamycin (AY 22,989), a new antifungal antibiotic. I: taxonomy of the producing streptomycete and isolation of the active principle. *J Antibiot* 28:721–726
- Waksman SA, Woodruff HB (1940) The soil as a source of microorganisms antagonistic to disease-producing bacteria. *J Bacteriol* 40:581–599
- Waksman SA, Woodruff HB (1941) *Actinomyces antibioticus*, a new soil organism antagonistic to pathogenic and non-pathogenic bacteria. *J Bacteriol* 42:231–249
- Weibel EK, Hadvary P, Hochuli E, Kupfer E, Lengsfeld H (1987) Lipstatin, an inhibitor of pancreatic lipase, produced by *Streptomyces toxytricini*. I. Producing organism, fermentation, isolation and biological activity. *J Antibiot* 40:1081–1085
- Weinstein MJ (2004) *Micromonospora* antibiotic discovery at schering/schering-plough (1961–1973). *SIM News* 54:56–66
- Weinstein MJ, Ludemann GM, Odem EM, Wagman GH (1963) Gentamicin, a new broad-spectrum antibiotic. *Antimicrob Agents Chemother* 161:1–7
- Wesseling AC, Lago B (1981) Strain improvement by genetic recombination of cephamycin producers, *Nocardia lactamdurans* and *Streptomyces griseus*. *Dev Ind Microbiol* 22:641–651
- Westley JW (1977) Polyether antibiotics: versatile carboxylic acid ionophores produced by *Streptomyces*. *Adv Appl Microbiol* 22:177–223
- Woodruff HB, McDaniel LE (1958) Antibiotic approach in strategy of chemotherapy. *Soc Gen Microbiol Symp* 8:29–48
- Woodruff HB, Hernandez S, Stapley EO (1979) Evolution of antibiotic screening programme. *Hindustan Antibiot Bull* 21:71–84
- Yu T, Shen Y, McDaniel R, Floss HG, Khosla C, Hopwood DA, Moore S (1998) Engineered biosynthesis of novel polyketides from *Streptomyces* spore pigment polyketide synthases. *J Am Chem Soc* 120:7749–7759

10 Biosurfactants

Eugene Rosenberg · Eliora Z. Ron

Department of Molecular Microbiology and Biotechnology, Tel Aviv University, Tel Aviv, Israel

Introduction	281
Chemical and Surface Properties of Biosurfactants	282
Glycolipids	282
Lipopeptides	284
Fatty Acids and Phospholipids	285
High-Molecular-Weight Biosurfactants	285
Other High-Molecular-Mass Biosurfactants	286
Genetics and Regulation of Bioemulsifier	
Production	287
Lipopeptides of Gram-Positive Bacilli	287
Rhamnolipids	287
Polymeric Bioemulsifiers	288
Natural Roles of Biosurfactants	289
Increasing the Surface Area of Hydrophobic	
Water-Insoluble Substrates	289
Increasing the Bioavailability of Hydrophobic	
Water-Insoluble Substrates	289
Regulating the Attachment-Detachment of	
Microorganisms to and from Surfaces	289
Potential Commercial Applications	290

Abstract

Microorganisms synthesize a wide variety of high- and low-molecular-mass bioemulsifiers. The low-molecular-mass bioemulsifiers are generally glycolipids, such as trehalose lipids, sphorolipids, and rhamnolipids, or lipopeptides, such as surfactin, gramicidin S, and polymyxin. The high-molecular-mass bioemulsifiers are amphipathic polysaccharides, proteins, lipopolysaccharides, lipoproteins, or complex mixtures of these biopolymers. The low-molecular-mass bioemulsifiers lower surface and interfacial tensions, whereas the higher-molecular-mass bioemulsifiers are more effective at stabilizing oil-in-water emulsions. Three natural roles for bioemulsifiers have been proposed: (1) increasing the surface area of hydrophobic water-insoluble growth substrates, (2) increasing the bioavailability of hydrophobic substrates by increasing their apparent solubility or desorbing them from surfaces, and (3) regulating the attachment and detachment of microorganisms to and from surfaces. Bioemulsifiers have several important advantages over chemical surfactants, which should allow them to become prominent in industrial and environmental applications. The potential commercial applications of bioemulsifiers include bioremediation of oil-polluted soil and water; enhanced oil recovery; replacement of chlorinated solvents used in cleaning-up

oil-contaminated pipes, vessels, and machinery; use in the detergent industry; formulations of herbicides and pesticides; and formation of stable oil-in-water emulsions for the food and cosmetic industries.

Introduction

Microorganisms are specialists. In any particular ecological niche, one microorganism or a limited number of strains dominate. These microorganisms have evolved the ability to survive in this niche for long periods when growth is impossible, and then when nutrients become available, they can outgrow their competitors. The fast growth of microorganisms depends largely on their high surface-to-volume ratio, which allows for the efficient uptake of nutrients and release of waste products. The price that the microorganism pays for the high surface-to-volume ratio is that it is totally exposed. All the components outside of the cell must function under the specific conditions of the ecological niche. Probably for this reason, the diversity of the microbial world is best expressed on the outside of the cell.

In any heterogeneous system, boundaries are of fundamental importance to the behavior of the system as a whole. Therefore, it is not surprising that microorganisms, having a large surface-to-volume ratio, produce a variety of surface-active agents (surfactants) that adsorb to and alter the conditions prevailing at interfaces. Surfactants concentrate at interfaces because they are amphipathic, that is, they contain both hydrophobic and polar groups. Biosurfactants can be divided into low-molecular-weight molecules that efficiently reduce surface and interfacial tensions and high-molecular-weight polymers that bind tightly to surfaces. ● [Tables 10.1](#) and [10.2](#) list some microbially produced surfactants that have been studied.

Numerous reviews have examined various aspects of biosurfactants such as their role in bacterial adhesion (Neu 1996) and in growth of bacteria on hydrocarbons (Rosenberg and Ron 1996), surface-active polymers from the genus *Acinetobacter* (Rosenberg and Ron 1998), biochemistry of surfactin (Peypoux et al. 1999), microbial surfactants (Rosenberg and Ron 1999), biosurfactant assay (Lin 1996), surfactants from *Rhodococci* (Lang and Philip 1998), production (Wang and Wand 1990), molecular genetics (Sullivan 1998), and commercial applications (Fiechter 1992), including enhanced oil recovery (Banat 1995), bioemulsions (Rosenberg and Ron 1997), role of biosurfactants (Ron and Rosenberg 2010a), and protein emulsifiers (Ron and Rosenberg 2010b). In this chapter, we

will present some of the chemical and surface properties of biosurfactants and the genetics and regulation of their production, and then we will discuss what functions they may play for the producing strains and what their potential is for commercial application.

When considering the natural roles and potential applications of biosurfactants, it is important to emphasize that a wide variety of diverse microorganisms (only some of which are shown in [Tables 10.1](#) and [10.2](#)) synthesize these molecules and that biosurfactants have very different chemical structures and surface properties. It is therefore reasonable to assume that different groups of biosurfactants have different natural roles in the growth of the producing microorganisms. Similarly, since their chemical structures and surface properties are so different, it is likely that each group of biosurfactants will have a specific use. This diversity makes it difficult to generalize about the natural role of biosurfactants and provides both advantages and disadvantages for potential commercial exploitation.

Chemical and Surface Properties of Biosurfactants

Glycolipids

The low-molecular-weight biosurfactants are generally glycolipids or lipopeptides ([Table 10.1](#)). The best studied glycolipid bioemulsifiers, rhamnolipids, trehalose lipids, and sophorolipids are disaccharides that are acylated with long-chain fatty acids or hydroxy fatty acids ([Figs. 10.1](#), [10.2](#), and [10.3](#)). Interest in trehalose lipids as general surfactants can be traced back to the discovery that the emulsion layer of *Arthrobacter paraffineus* culture broths contained trehalose dimycolates when the cells were grown on hydrocarbon substrates (Suzuki et al. 1969). Wagner and coworkers (1983) have studied trehalose dimycolates produced by *Rhodococcus erythropolis* extensively with special reference to their interfacial activities and possible application in enhanced oil recovery (Kim et al. 1990). When *R. erythropolis* was grown in batch fermentor cultures on 2 % (w/w) C₁₂–C₁₈ *n*-alkanes, the maximum amounts of trehalose lipids and dry cell mass were 2.1 and 19 g/l, respectively (Rapp et al. 1979). Yields of trehalose lipids were increased to 4 g/l when the bacteria were grown on 10 % (w/v) *n*-alkanes and the trehalose lipids were continuously extracted. Recently, the yield of rhamnolipids was increased to 24.3 g/l in media containing 6 % canola oil (Sim et al. 1997). Surfactant production is growth associated (Espuny et al. 1996). Essentially all of the trehalose lipids of *R. erythropolis* are cell bound and extractable with *n*-hexane. The surfactant properties of the fractionated cell-bound lipids of *R. erythropolis* were measured by Kretschmer et al. 1982. The minimal interfacial tensions (between aqueous salt solutions and *n*-hexadecane) achieved with corynomycolic acids, trehalose monocorynomycolates, and trehalose dicorynomycolates were 6, 16, and 17 mN/m, respectively. However, the critical micelle concentration (CMC) for the trehalose lipids (ca. 2 mg/l) was more than 100

Table 10.1

Low-molecular-mass microbially produced surfactants.

Surfactant	Producing microorganisms	References
Rhamnolipids	<i>P. aeruginosa</i>	Rendell et al. (1990)
		Sim et al. (1997)
		Lang and Wullbrandt (1999)
	Arino et al. (1996)	
	<i>Pseudomonas</i> spp.	Parra et al. (1989)
Trehalose lipids	<i>R. erythropolis</i>	Ristau and Wagner (1983)
		Kim et al. (1990)
		Lang and Philip (1998)
	<i>Arthrobacter</i> sp.	Li et al. (1984)
	<i>Mycobacterium</i> sp.	Cooper et al. (1989)
Sophorolipids	<i>T. bombicola</i> (yeast)	Inoue and Itoh (1982)
		Davila et al. (1997)
Glucose lipids	<i>A. borkumensis</i>	Yakimov et al. (1998)
		Abraham et al. (1998)
	<i>C. bogoriensis</i> (yeast)	Cutler and Light (1979)
Viscosin	<i>P. fluorescens</i>	Neu and Poralla (1990)
Surfactin	<i>B. subtilis</i> <i>B. velezensis</i>	Arima et al. (1968)
		Wei and Chu (1998)
		Liu et al. (2010)
Gramicidin S	<i>B. brevis</i>	Katz and Demain (1977)
Polymyxins	<i>B. polymyxa</i>	Suzuki et al. (1965)
Serrawettin	<i>S. marcescens</i>	Matsuyama et al. (1991)
		Pruthi and Cameotra (1997)
Lipopeptide	<i>B. Licheniformis</i>	Horowitz and Griffin (1991)
		Lin et al. (1994)
		Yakimov et al. (1995)
Lipopeptide	<i>S. liquefaciens</i>	Lindum et al. (1998)
Streptofactin	<i>S. tendae</i>	Richter et al. (1998)
Corynomycolic acids	<i>N. erythropolis</i>	MacDonald et al. (1981)
	<i>C. lepus</i>	Cooper et al. (1981)
Phospholipids	<i>Acinetobacter</i> spp.	Kaeppli and Finnerty (1980)
	<i>T. thiooxidans</i>	Beebe and Umbreit (1971)
Fatty acids	Widespread	MacDonald et al. (1981)

times lower than that for the free corynomycolic acids. Trehalose mycolates reduced the surface tension of water from 72 to 26 mN/m (Lang and Philip 1998).

Different species of the yeast *Torulopsis* produce extracellular sophorolipids, which consist of two glucose units linked β-1,2.

■ Table 10.2
High-molecular-mass microbially produced surfactants

Surfactant	Producing microorganisms	References
RAG-1 emulsan	<i>A. calcoaceticus</i> RAG-1	Rosenberg et al. (1979a)
BD4 emulsan	<i>A. calcoaceticus</i> BD413	Kaplan and Rosenberg (1982)
Alasan	<i>A. radioresistens</i> KA53	Navon-Venezia et al. (1995)
Glycoprotein	Antartic bacterium	Gutierrez et al. (2007)
Biodispersan	<i>A. calcoaceticus</i> A2	Rosenberg (1993)
Mannan-lipid-protein	<i>C. tropicalis</i>	Kaeppli et al. (1984)
Liposan	<i>C. lipolytica</i>	Cirigliano and Carman (1984)
Emulsan 378	<i>P. fluorescens</i>	Persson et al. (1988)
Glycoprotein	<i>Myroides</i> sp.	Maneerat et al. (2006)
Protein complex	<i>M. thermoautotrophium</i>	De Acevedo and McInerney (1996)
Insecticide emulsifier	<i>P. tralucida</i>	Appaiah and Karanth (1991)
Thermophilic emulsifier	<i>B. stearotherophilus</i>	Gunjar et al. (1995)
Acetylheteropolysaccharide	<i>S. paucimobilis</i>	Ashtaputre and Shah (1995)
Food emulsifier	<i>C. utilis</i>	Shepherd et al. (1995)
Sulfated polysaccharide	<i>H. eurihalinia</i>	Calvo et al. (1998)
PM-factor	<i>P. marginalis</i>	Burd and Ward (1996)
Extracellular polysaccharide	<i>Pseudomonas putida</i> ML2	Bonilla et al. (2005)
Emulcyan	<i>Phormidium</i> J-1	Fattom and Shilo (1985)

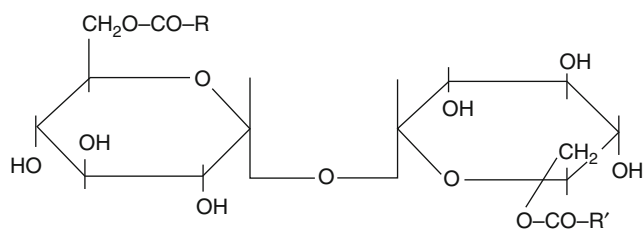

■ Fig. 10.1
 β , β -Trehalose-6,6'-dicarboxylic ester. Trehalose lipids differ in the structure of the R and R' groups

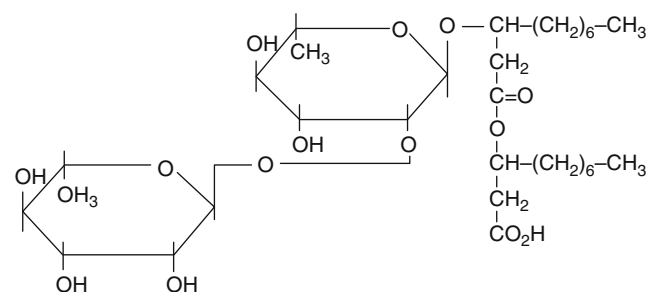

■ Fig. 10.3
Structure of the rhamnolipid of *Pseudomonas aeruginosa*

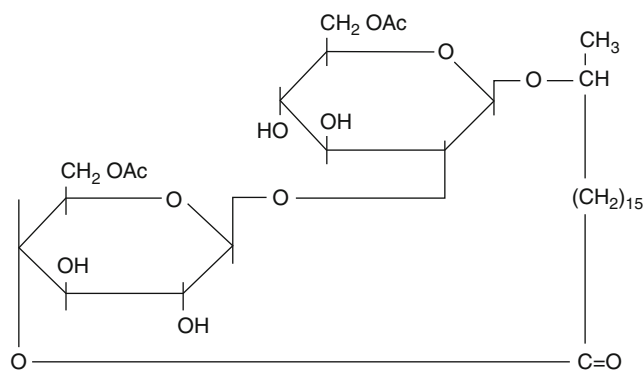

■ Fig. 10.2
Structure of the lactonic sophorose lipid of *Torulopsis bombicola*

The 6 and 6' hydroxyl groups are generally acetylated. The lipid portion is connected to the reducing end through a glycosidic linkage. The terminal carboxyl group of the fatty acid can be in the lactonic form (as shown in Fig. 10.2) or hydrolyzed to generate an anionic surfactant. High yields of sophorose lipids can be obtained from the extracellular fluid of cultures of *T. bombicola* grown on glucose and oil. For example, Itoh and Inoue 1982 reported yields of 32 g/l of a crude sophorolipid mixture when the bacteria were grown in shaker flasks on a glucose-safflower oil medium. Under controlled conditions in a 7-l fermentor, the maximum yield of sophorose lipids from *T. bombicola* ATCC 22214 was about 70 g/l when the medium contained both glucose and a vegetable oil as substrates (Cooper and Paddock 1983). More recently, yields have improved to over 150 g/l (Davila et al. 1997; Rau et al. 1996;

Zhou and Kosaric 1995), making potential commercial exploitation more feasible. The sophorose lipids lower surface and interfacial tensions, although they are not effective emulsifying agents (Cooper and Paddock 1983). The pure lactonic sophorose lipid (10 mg/l) lowered the interfacial tension between *n*-hexadecane and water from 40 to about 5 mN/m, relatively independent of pH (6–9), salt concentration, and temperature (20–90 °C). The minimum interfacial tensions brought about by a mixture of acidic sophorose lipids against hexadecane or several vegetable oils were 1–2 mN/m.

Certain species of *Pseudomonads* are known to produce large quantities of a glycolipid (Hauser and Karnovsky 1954) consisting of 2 mol of rhamnose and 2 mol of β -hydroxydecanoic acid. The hydroxyl group of one of the acids is involved in glycosidic linkage with the reducing end of the rhamnose disaccharide, whereas the hydroxyl group of the second acid is involved in ester formation. Since one of the carboxylic groups is free, the rhamnolipids are anions above pH 4. Rhamnolipid was reported (Hisatsuka et al. 1971) to lower surface tension, emulsify hydrocarbons, and stimulate growth on *n*-hexadecane of *P. aeruginosa* strains but not other hydrocarbon-degrading bacteria. Formation of rhamnolipids by *P. aeruginosa* has been studied (Wagner et al. 1983; Guerra-Santos et al. 1986; Lang and Wullbrandt 1999). More than 100-g/l rhamnolipids were produced from 160-g/l soybean oil (Lang and Wullbrandt 1999). The pure rhamnolipid lowered the interfacial tension against *n*-hexadecane to about 1 mN/m and had a CMC of 10–30 mg/l, depending on the pH and salt conditions (Lang and Wagner 1987; Parra et al. 1989).

Zhang and Miller 1995 reported that the interfacial tension between hexadecane and water was decreased to less than 0.1 mN/m by a methyl ester of rhamnolipid, whereas the free acid decreased the interfacial tension only to 5 mN/m. Mannosylerythritol lipids (extracellular microbial surfactants) have several interesting biological properties. They inhibit growth of human promyelocytic leukemia cell lines and induce monocytic differentiation (Isoda et al. 1997). Furthermore, the surfactant inhibited serine/threonine phosphorylations in intact leukemia cells. The authors suggest that the differentiation-inducing ability of mannosylerythritol lipids is not due to a simple detergent-like effect but rather is the result of a specific action on the plasma membrane.

Recently, a new class of glycolipid, glucose lipids, has been described (Yakimov et al. 1998; Abraham et al. 1998). These glucose lipids are produced by a new bacterial genus and species, *Alcanivorax borkumensis* (Golyshin et al. 1998). During cultivation on *n*-alkanes as sole source of carbon and energy, this novel marine bacterium produced extracellular and cell-bound surface-active glucose lipids which reduced the surface tension of water from 72 to 29 mN/m. Ten different glucose lipids were separated, and their structures elucidated. They all consist of an anionic glucose lipid with a tetrameric oxyacyl side chain. The glucose lipids extracted from the cell envelope were *N*-terminally esterified with glycine. The glucose lipids differ in the chain length of one or two of the four β -hydroxy fatty acids.

Lipopeptides

Several lipopeptide antibiotics show potent surface-active properties. *Bacillus subtilis* produces a cyclic lipopeptide called surfactin or subtilisin (Peypoux et al. 1999; Bernheimer and Avigad 1970; Arima et al. 1968), which is reputedly the most active biosurfactant known to date (Cooper and Zajic 1980). The structure of surfactin is shown in Fig. 10.4. Surfactin has a CMC in water of 25 mg/l and lowers the surface tension to 27 mN/m. The minimum interfacial tension against hexadecane was 1 mN/m. The yield of surfactin produced by *B. subtilis* can be improved to around 0.8 g/l by continuously removing the surfactant by foam fractionation and addition of either iron or manganese salts to the growth medium (Cooper et al. 1981). Wei and Chu 1998 obtained a yield of 3.5 g/l by carefully controlling iron concentration and pH. A recombinant *B. subtilis*, carrying a gene for surfactin production, produced new surfactin variants (Nakayama et al. 1997). The amphipathic nature of surfactin may contribute to some of its interesting biological properties, such as the formation of ion-conducting pores in membranes (Grau et al. 1999). Recently, surfactin was shown to be present in the marine bacterium *Bacillus velezensis* (Liu et al. 2010).

Streptomyces tendae produces an extracellular hydrophobic peptide referred to as streptofactin (Richter et al. 1998). Streptofactin is a mixture of structurally related peptides ranging in molecular mass from 1,003 to 1,127 Da. Streptofactin reduced the surface tension of water from 72 mN/m to 39.4 mN/m and had a critical micelle concentration of 36 mg/l. Interestingly, streptofactin restored the ability of mutants defective in aerial mycelium formation to develop normally. It was suggested that streptofactin plays a role in *Streptomyces* development by allowing for the erection of aerial hyphae by lowering the surface tension of water films enclosing the colonies.

The synthesis of one or more peptide antibiotic during the early stages of sporulation is common to most, if not all,

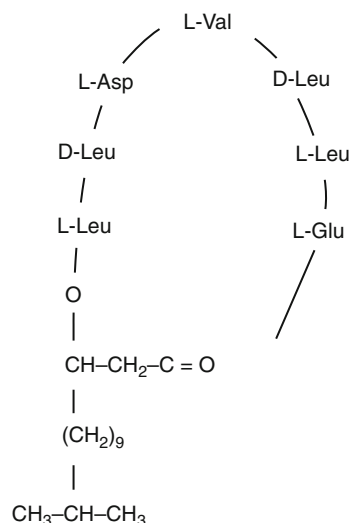
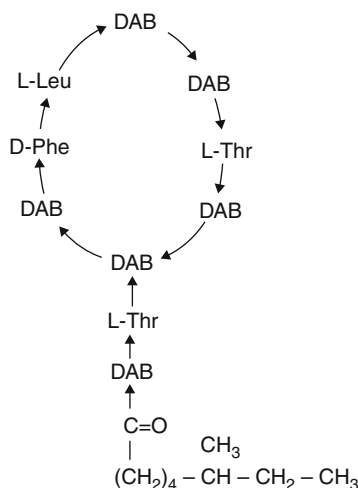

Fig. 10.4
Surfactin



■ Fig. 10.5
Polymyxin B. DAB is 2,4-diaminobutyric acid

members of the genus *Bacillus* (Katz and Demain 1977). *B. brevis* produces the cyclosymmetric decapeptide antibiotic gramicidin S. In solution, gramicidin S exists in the form of a rigid ring with the two positively charged ornithine side chains constrained to one side of the ring, an average of 8 nm apart, and the side chains of the remaining hydrophobic residues oriented toward the opposite side of the ring (Krauss and Chan 1983). As a result, gramicidin S will bind strongly to negative surfaces and polyanions, causing them to become lipophilic. For example, two moles of gramicidin S form a stable coordination complex with one molecule of ATP, which partitions into organic solvents.

The polymyxins are a group of closely related lipopeptide antibiotics produced by *B. polymyxa* and related bacilli. As seen in ▶ Fig. 10.5, polymyxin B is a decapeptide in which amino acids 3 through 10 form a cyclic octapeptide. A branched-chain fatty acid is connected to the terminal 2,4-diaminobutyric acid (DAB). The structures of polymyxins differ in substituents at residues 3 (DAB or D-Ser), 6 (D-Leu or L-Ileu), or 7 (D- or L-DAB) (Suzuki et al. 1965). The cationic 7γ -amino groups of the DAB residues, together with the hydrophobic side chain of the fatty acid, give these antibiotics the surface-active properties of a cationic detergent. *Pseudomonas* strains produce viscosin, a peptidolipid biosurfactant which lowers surface tension of water to 27 mN/m (Neu et al. 1992).

Fatty Acids and Phospholipids

Fatty acids derived from alkanes have received considerable attention as surfactants. Rehm and Reiff 1981 have published a detailed list of fatty acids resulting from the microbial oxidation of alkanes. The hydrophilic-lipophilic balance (HLB) of fatty acids is clearly related to the length of the hydrocarbon chain. For lowering surface and interfacial tensions, the most active saturated fatty acids are in the range of C-12 to C-14. In addition to straight-chain fatty acids, microorganisms produce

complex fatty acids containing hydroxyl groups and alkyl branches. Some of these complex fatty acids, for example, the corynomycolic acids, are potent surfactants (MacDonald et al. 1981). Similar to two-hydroxy fatty acid surface properties, the surface properties of corynomycolic acids are relatively insensitive to pH and ionic strength.

Phospholipids are major components of microbial membranes. When certain hydrocarbon-degrading bacteria or yeast is grown on alkane substrates, the level of phospholipid increases greatly. In the case of hexadecane-grown *Acinetobacter* sp. HO1-N, phospholipid-rich (mainly phosphatidylethanolamine) extracellular membrane vesicles accumulate in the medium (Kaeppli and Finnerty 1979). The potent surfactant properties of these vesicles are evident from the observation that they are able to generate optically clear microemulsions of alkanes in water (Kaeppli and Finnerty 1980). Surfactant properties of cellular phospholipids of *Rhodococcus erythropolis* grown on *n*-alkanes were examined by Kretschmer et al. 1982. The phosphatidylethanolamine fraction was the most potent, lowering the interfacial tension between water and hexadecane to less than 1 mN/m and having a CMC of 30 mg/l. The surface properties of phospholipids are influenced greatly by changes in pH and ionic strength. Phospholipids produced by *Thiobacillus thiooxidans* have been reported to be responsible for wetting elemental sulfur, which is necessary for growth (Beebe and Umbreit 1971).

High-Molecular-Weight Biosurfactants

A large number of bacterial species from different genera produce exocellular polymeric surfactants composed of polysaccharides, proteins, lipopolysaccharides, lipoproteins, or complex mixtures of these biopolymers (▶ Table 10.2). The best studied are the bioemulsans produced by different species of *Acinetobacter* (Rosenberg and Ron 1998). The RAG-1 emulsan is a complex of an anionic heteropolysaccharide and protein (Rosenberg et al. 1979b; Rosenberg and Kaplan 1987). Its surface activity is due to the presence of fatty acids, comprising 15 % of the emulsan dry weight, that are attached to the polysaccharide backbone via *O*-ester and *N*-acyl linkages (Belsky et al. 1979). ▶ Table 10.3 summarizes the chemical and physical properties of RAG-1 emulsan. *A. calcoaceticus* RAG-1 excretes maximum amounts of emulsan in shaker flasks when grown in a minimal medium containing 2 % ethanol as the sole carbon and energy source. Under these conditions, approximately 80 % of the emulsan produced is released when the cells are in stationary phase (Goldman et al. 1982). Emulsan is an effective emulsifier at low concentrations (0.01–0.001 %), representing emulsan-to-hydrocarbon ratios of 1:100–1:1,000, and exhibits considerable substrate specificity (Rosenberg et al. 1979a). The RAG-1 emulsan does not emulsify pure aliphatic, aromatic, or cyclic hydrocarbons; however, all mixtures that contain an appropriate mixture of an aliphatic and an aromatic (or cyclic alkane) are emulsified efficiently. Maximum emulsifying activity is obtained in the presence of divalent cations (2–10 mM Mg^{2+}) at pH values of 5.0–7.5.

Table 10.3
Chemical and physical properties of RAG-1 emulsan^a

Measurement	Result
Chemical composition	D-galactosamine, 25 %
	L-galactosaminouric acid, 25 %
	Dideoxy-diaminohexose, 25 %
	3-hydroxydodecanoic acid, 10 %
	2-hydroxydodecanoic acid, 10 %
	Water and ash, 10 %
Intrinsic viscosity	55 cc/g
Diffusion constant	5.3×10^{-8} cm ² /g
Partial molar volume	0.71 cm ³ /g
Molecular weight	98×10^5 Da
Dimensions	30 Å × 2,000 Å

^aData taken from Rosenberg et al. (1979a)

Acinetobacter calcoaceticus BD4, initially isolated and characterized by Taylor and Juni 1961, produces a large polysaccharide capsule. Under certain growth conditions (e.g., 2 % ethanol as the carbon and energy source), an enhanced release of the capsules was obtained (Sar and Rosenberg 1983). However, in contrast to RAG-1, no decrease in capsular polysaccharide was observed; rather, capsular polysaccharide levels remained constant when enhanced levels of extracellular polysaccharide were obtained (Kaplan and Rosenberg 1982). When the crude capsule was applied to a Sepharose 4B column, it eluted in a single peak containing a polysaccharide-protein complex. The pure polysaccharide component was obtained by deproteinization, and its chemical structure elucidated (▶ Fig. 10.6). The protein component was obtained from the extracellular supernatant fluid of strain BD4-R7, a capsule-negative mutant of BD4 that produces no extracellular polysaccharide. The polysaccharide and protein components had no emulsifying activity by themselves. Mixing the protein and polysaccharide fractions led to a reconstitution of the emulsifying activity (Kaplan et al. 1987). Apparently the protein, which is hydrophobic, binds to the hydrocarbon initially in a reversible fashion. The polysaccharide then attaches to the protein and stabilizes the oil-in-water emulsion.

Alasan, produced by a strain of *Acinetobacter radioresistens*, is a complex of an anionic polysaccharide and protein with a molecular weight of approximately 1×10^6 (Navon-Venezia et al. 1995). However, the polysaccharide component of alasan is unusual in that it contains covalently bound alanine. The protein component of alasan appears to play an important role in both the structure and activity of the complex (Navon-Venezia et al. 1998). Deproteinization of alasan with hot phenol or treatment with specific proteinases caused a loss in most of the emulsifying activity. When a solution of alasan was exposed to increasing temperatures, there were large changes in the viscosity and emulsifying activity of the complex. Between 30 °C and 50 °C, the viscosity increased 2.6 times with no change in activity. Between 50 °C and 90 °C, the viscosity decreased 4.8

times and the activity increased fivefold. None of these changes occurred with the protein-free polysaccharide, indicating that they were due to the interactions of the protein and polysaccharide portions of the complex. Alasan lowers interfacial tension from 69 to 41 mN/m at 20 °C and has a CMC of 200 µg/ml (Barkay et al. 1999). Alasan enhanced the aqueous solubility and biodegradation rates of polyaromatic hydrocarbons (Barkay et al. 1999). In the presence of 0.5-mg alasan per ml, the apparent solubilities of phenanthrene, fluoranthene, and pyrene were increased 6.6-, 25.7-, and 19.8-fold, respectively. Alasan binds polyaromatic hydrocarbons in a reversible manner. The presence of alasan more than doubled the rate of [¹⁴C] phenanthrene mineralization by *Sphingomonas paucimobilis*. The solubilization of polyaromatic hydrocarbons and emulsification of hydrocarbons can be accomplished with the purified alasan proteins (Rosenberg et al. 1999). One of the alasan proteins, with an apparent molecular mass of 45 kDa, was studied at the molecular level. This protein has an amino acid sequence homologous to that of *Escherichia coli* OmpA and is highly effective in stabilizing oil-in-water emulsions and in solubilizing hydrocarbons, including polycyclic aromatic hydrocarbons (Toren et al. 2002a, b).

A. calcoaceticus A2 produces an extracellular anionic polysaccharide surfactant of molecular mass 51.4 kDa that effectively disperses limestone and titanium dioxide (Rosenberg et al. 1988a, b). The biopolymer, referred to as biodispersan, binds to powdered calcium carbonate and changes its surface properties in a way that allows for better dispersion in water. In addition to being a surfactant, biodispersan acts also as a surfactant, aiding in the fracturing of limestone during the grinding process (Rosenberg et al. 1989).

Sar and Rosenberg 1983 reported that the majority of *Acinetobacter* strains produce extracellular nondialyzable emulsifiers. These strains included both soil and hospital isolates. Marin et al. 1996 have reported the isolation of a strain of *A. calcoaceticus* from contaminated heating oil that emulsifies that substrate. Neufeld and Zajic 1984 demonstrated that whole cells of *A. calcoaceticus* 2CA2 have the ability to act as emulsifiers, in addition to producing an extracellular emulsifier.

Other High-Molecular-Mass Biosurfactants

A large number of high-molecular-weight complex biosurfactants have been reported. In general, little is known about these emulsifiers other than the producing organism and the overall chemical composition of the crude mixture. *Halomonas eurihalina* produces an extracellular sulfated heteropolysaccharide (Calvo et al. 1998). *Pseudomonas tralucida* produced an extracellular-acetylated polysaccharide that was effective in emulsifying several insecticides (Appaiah and Karanth 1991). Several recently reported biosurfactants are effective at high temperature, including the protein complex from *Methanobacterium thermoautotrophium* (De Acevedo and McInerney 1996) and the protein-polysaccharide-lipid complex of *Bacillus stearothermophilus* ATCC 12980

which is located in the periplasm. The expression of the *rhlAB* genes in *Escherichia coli* led to the formation of active rhamnosyltransferase. Recently, another gene—*rhlG*—essential for the biosynthesis of rhamnolipids has been identified by insertional mutation (Campos-Garcia et al. 1998). This gene is homologous to the *fabG* gene, which encodes the NADPH-dependent β -ketoacyl-acyl carrier protein (ACP) reductase required for fatty acid synthesis. Insertional mutants in this gene grew normally, and the mutation had no apparent effect on the total lipid content of the cells, but the production of rhamnolipids was completely inhibited. These results suggest that the synthetic pathway for the fatty acid moiety of rhamnolipids is separate from the general fatty acid synthetic pathway, starting with a specific ketoacyl reduction step catalyzed by the RhlG protein. The existence of synthetic pathways for emulsifiers that are homologous but distinct from the general fatty acid synthetic pathway may well be a general characteristic of emulsifier biosynthesis, as a *fabG* homologue that is nonessential for growth was also identified in a hydrocarbon-degrading strain of *A. junii* (Sapir 1998).

Production of rhamnolipids occurs at the stationary phase of growth, and recent experiments demonstrated that it is controlled by quorum sensing (Brint and Ohman 1995; Ochsner and Reiser 1995; Pearson et al. 1997). The *rhlAB* gene cluster coding for the biosynthesis of rhamnolipids contains two additional genes that encode regulatory proteins (RhlR and RhlI). These proteins share significant sequence similarity with bacterial autoinducer synthetases of the LuxI type. The RhlR is a putative transcriptional activator, and the RhlI protein directs the synthesis of the quorum-sensing inducer *N*-butyryl homoserine lactone (PAI-2). The RhlR-RhlI regulatory system is essential for the regulation of rhamnolipid production. Moreover, rhamnolipid synthesis also is regulated by another regulatory system, the LasR-LasI system, which controls the biosynthesis of elastase. This is also a quorum-sensing system that consists of a transcriptional activator, LasR, and LasI, which directs the synthesis of the autoinducer *N*-(3-oxododecanoyl) homoserine lactone (PAI-1). There is sequence homology between the LasR-LasI proteins and the RhlR-RhlI proteins, and there is cross-communication between the two quorum-sensing systems. It has been shown that LasR together with PAI-1 regulates transcription of the *rhlR* gene (Campos-Garcia et al. 1998; Latifi et al. 1996; Latifi et al. 1995; Ochsner et al. 1994; Pearson et al. 1997; Pesci et al. 1997; Van Delden et al. 1998).

Polymeric Bioemulsifiers

Polymeric bioemulsifiers are more complex than the low-molecular-weight lipopeptides and rhamnolipids. The synthesis of high-molecular-weight heteropolysaccharides requires a large number of genes, and the genetics is even more complex for polysaccharide-protein complexes. From the genetics point of view, the best studied polysaccharide bioemulsifier is the one produced by *A. calcoaceticus* BD4. The genes involved in its

synthesis were identified in a cosmid library that was used to complement nonproducing mutants (Stark 1996). These biosynthetic genes are organized in a cluster of about 60 kilobases. The first gene in the biosynthesis of the BD4 emulsifier (Accession no. X89900) was identified as a homologue of genes coding for phosphoglucosyltransferase (*pgi*). The product of this gene is a protein of about 60 kDa in molecular weight that carries out the bidirectional conversion of glucose-6-phosphate to fructose-6-phosphate. The gene is highly conserved from bacteria to mammals, with about 40 % homology in amino acids. Additional genes in the cluster (*epsX* and *epsM*, accession no. X81320) show homology to the genes coding for GDP-mannose pyrophosphorylase and phosphomannose isomerase of enteric bacteria (Stark 1996). It is interesting to note that mutants in the *epsX* and *epsM* genes grow poorly under conditions that favor the formation of the bioemulsifier, and these deleterious mutations can be overcome by an additional (suppressor) mutation in the first gene in the pathway: *pgi*. These results suggest that mutants in the biosynthesis of the polysaccharide accumulate a toxic intermediate, probably fructose-6-phosphate (Fraenkel 1992). The accumulation of the toxic substance, as well as the inhibition of growth, can be overcome by a mutation in a previous metabolic reaction, since the mutation blocks the synthesis of this toxic intermediate. The finding that some mutants in capsule synthesis grow poorly under conditions that favor capsule synthesis may explain the difficulty often encountered in getting such mutants (as an example, mutants unable to synthesize alasin were not obtained after screening more than 7,000 transposants of *A. radioresistens* KA53; Dahan 1998). As screening for the mutants is usually performed on media that maximize the contrast between the capsule-producing wild-type and mutant organisms (i.e., media that favor capsule formation), it is possible that these conditions are strongly inhibitory, or even lethal, for many of the mutants.

In *Acinetobacter*, the production of polysaccharide bioemulsifiers is concurrent with stationary phase. It has also been suggested that UDP-glucose, one of the precursors in the synthesis of polysaccharide bioemulsifiers, is a signal molecule in the control of σ -S and σ -S-dependent genes (Bohringer et al. 1995). The bioemulsifier of *A. calcoaceticus* BD4 (Kaplan and Rosenberg 1982), emulsan of *A. calcoaceticus* RAG-1 (Rubinovitz et al. 1982), biodispersan of *A. calcoaceticus* A2 (Rosenberg et al. 1988a), alasin of *A. radioresistens* (Dahan 1998; Navon-Venezia et al. 1995), and an uncharacterized bioemulsifier from *A. junii* (Goldenberg-Dvir 1998) can be detected in cultures only after more than 10 h of growth, and maximal production occurs when the cultures have progressed well into the stationary phase. These results suggest the possibility that the high-molecular-weight bioemulsifiers are also controlled by quorum sensing, although there is, as yet, no direct proof.

The results presented here suggest that production of bioemulsifiers by bacteria is correlated with high bacterial density. This finding may be fortuitous or may reflect an indirect

correlation with one or more physiological factors affected by high bacterial density such as availability of energy, nitrogen, or oxygen. However, it is possible that the production of bioemulsifiers at high bacterial density has a selective advantage. For emulsifiers produced by pathogens, Sullivan 1998 suggested that, being virulence factors, they are produced when the cell density is high enough to cause a localized attack on the host. It is easier to explain the need for bioemulsifiers in bacteria growing on hydrocarbons. As these bacteria are growing at the oil-water interphase, production of emulsifiers when the density is high will increase the surface area of the drops, allowing more bacteria to feed. Furthermore, when the utilizable fraction of the hydrocarbon is consumed, as in the case of oil that consists of many types of hydrocarbons, the production of the emulsifiers allows the bacteria to detach from the “used” droplet and find a new one (Rosenberg et al. 1983).

Natural Roles of Biosurfactants

The question “what is the natural role of microbial surfactants” would appear to be of fundamental significance in microbial physiology and of practical value in designing selection methods for improved molecules. However, the question has a basic flaw. There is no reason to suspect that surfactants have *one* natural role. As described in this chapter, microbial surfactants have very different structures, are produced by a wide variety of microorganisms, and have very different surface properties. Thus, it will be necessary to analyze each surfactant, or group of surfactants, separately. Only then may it be possible to draw any generalizations.

There are relatively few data available on the natural roles of biosurfactants, that is, what function they play for the producing organisms. In only a few cases have nonbiosurfactant-producing mutants been generated and compared to the parent strain (Itoh and Suzuki 1972; Koch et al. 1991). Thus, most of the concepts have been derived from a consideration of the surface properties of the biosurfactants and experiments in which biosurfactants are added to microorganisms growing on water-insoluble substrates. At least three general hypotheses have emerged.

Increasing the Surface Area of Hydrophobic Water-Insoluble Substrates

Theoretical and experimental studies on the production of single-cell protein from hydrocarbons in fermentors demonstrated that the growth rate can be limited by the interfacial surface area between water and oil (Sekelsky and Shreve 1999). When the surface area becomes limiting, biomass increases arithmetically rather than exponentially. The evidence that emulsification is a natural process brought about by extracellular agents is indirect, and understanding how emulsification can provide an (evolutionary) advantage for the microorganism producing the emulsifier has certain conceptual difficulties. Stated briefly,

emulsification is a cell density-dependent phenomenon, that is, the greater the number of cells, the higher the concentration of extracellular product. The concentration of cells in an open system, such as an oil-polluted body of water, never reaches a high enough value to effectively emulsify oil. Furthermore, any emulsified oil would disperse in the water and not be more available to the emulsifier-producing strain than to competing microorganisms. One way to reconcile the existing data with these theoretical considerations is to suggest that the emulsifying agents do play a natural role in oil degradation but not in producing macroscopic emulsions in the bulk liquid. If emulsion occurs at or very close to the cell surface and no mixing occurs at the microscopic level, then each cell creates its own microenvironment and a local cell density dependence would be expected.

Increasing the Bioavailability of Hydrophobic Water-Insoluble Substrates

One of the major reasons for the prolonged persistence of high-molecular-weight hydrophobic compounds is their low water solubility, which increases their sorption to surfaces and limits their availability to biodegrading microorganisms. When organic molecules are bound irreversibly to surfaces, biodegradation is inhibited (van Loosdrecht et al. 1990). Biosurfactants can enhance growth on bound substrates by desorbing them from surfaces or by increasing their apparent water solubility (Deziel et al. 1996). Surfactants that lower interfacial tension dramatically are particularly effective in mobilizing bound hydrophobic molecules and making them available for biodegradation. Low-molecular-weight biosurfactants that have low CMCs increase the apparent solubility of hydrocarbons by incorporating them into the hydrophobic cavities of micelles (Miller and Zhang 1997). Data have been reported which indicate that biosurfactants can stimulate, inhibit, or have no effect on biodegradation of hydrocarbons (reviewed in Bruheim et al. 1997). In this regard, Arino et al. 1998 have reported that a rhamnolipid-producing strain of *P. aeruginosa* is involved in the degradation of PAHs by a bacterial community. Enzymatically synthesized lauroyl glucose emulsified different hydrophobic substrates and enhanced degradation of crude oil by a known oil-degrading *Rhodococcus* species (Kelkar et al. 2007). Much less is known on how polymeric biosurfactants increase apparent solubilities of hydrophobic compounds. It has been demonstrated that alasan increases the apparent solubilities of PAHs 5–20-fold and significantly increases their rate of biodegradation (Rosenberg et al. 1999; Barkay et al. 1999).

Regulating the Attachment-Detachment of Microorganisms to and from Surfaces

One of the most fundamental survival strategies of microorganisms is their ability to locate themselves in an ecological niche

where they can multiply. This is true not only for microbes that live in or on animals and plants but also for those that inhabit soil and aquatic environments. The key elements in this strategy are cell surface structures which are responsible for the attachment of the microbes to the proper surface. Neu 1996 has reviewed how surfactants can affect the interaction between bacteria and interfaces. If a biosurfactant is excreted, it can form a conditioning film on an interface, thereby stimulating certain microorganisms to attach to the interface while inhibiting the attachment of others. In the case where the substrate is also a water-insoluble substrate, for example, sulfur and hydrocarbons, the biosurfactant stimulates growth (Beebe and Umbreit 1971; Bunster et al. 1989). If the biosurfactant is cell bound, it can cause the microbial cell surface to become more hydrophobic, depending on its orientation. For example, the cell surface hydrophobicity of *P. aeruginosa* was greatly increased by the presence of cell-bound rhamnolipid (Zhang and Miller 1994), whereas the cell surface hydrophobicity of *Acinetobacter* strains was reduced by the presence of its cell-bound emulsifier (Rosenberg et al. 1983). These data suggest that microorganisms can use their biosurfactants to regulate their cell surface properties to attach or detach from surfaces according to need. This has been demonstrated for *A. calcoaceticus* RAG-1 growing on crude oil (Rosenberg 1993). During exponential growth, emulsan is cell bound in the form of a minicapsule. This bacterium utilizes only relatively long-chain *n*-alkanes for growth. After these compounds are utilized, RAG-1 becomes starved, although it is still attached to the oil droplet enriched in aromatics and cyclic paraffins. Starvation of RAG-1 causes release of the minicapsule of emulsan. It was shown that this released emulsan forms a polymeric film on the *n*-alkane-depleted oil droplet, thereby desorbing the starved cell (Rosenberg et al. 1983). In effect, the “emulsifier” frees the cell to find fresh substrate. At the same time, the depleted oil droplet has been “marked” as used because it now has a hydrophilic outer surface to which the bacterium cannot attach.

Potential Commercial Applications

Bioemulsifiers have several important advantages over chemical surfactants, which should allow them to become prominent in several industrial and environmental uses. Bioemulsifiers are produced from renewable resources, are biodegradable, and are active under a variety of conditions. Of special interest are the emulsifiers produced by thermophilic and halophilic bacterial species (Trebbaud-de and McInerney 1996; Makkar and Cameotra 1997). Although not extensively studied so far, they present unique possibilities for applications involving extreme conditions of pH, salinity, and temperature (Desai and Banat 1997). It is interesting that an arctic strain, *Arthrobacter protophormiae*, produces a heat-stable bioemulsifier (Pruthi and Cameotra 1997).

One obvious application is in the oil and petroleum industries (Rosenberg 1993). As surfactants increase the oil–water surface area, they accelerate degradation of various oils by

bacteria and improve bioremediation of water and soil (Banat 1995; Bruheim et al. 1997; Volkering et al. 1997). Surfactants are important for microbially enhanced oil recovery as well as for cleanup of storage tanks and pipes. Moreover, some bioemulsifiers are capable of increasing the bioavailability of poorly soluble organic compounds, such as polycyclic aromatics (PAHs). One such emulsifier—alasan (Navon-Venezia et al. 1995)—increases the solubility of several PAHs, such as phenanthrene, flourene, and pyrene, and significantly accelerates the rate of their mineralization (Barkay et al. 1999). Similar results were obtained for the biodegradation of polychlorinated biphenyls (PCBs) in the presence of a bioemulsifier produced on sunflower (Fiebig et al. 1997; Robinson et al. 1996).

In the detergent and cleaning industries, it is important to remove hydrocarbons or fatty materials. Bioemulsifiers have three major advantages for these applications: the environmental consequences of their use are minimal, and their addition can reduce the concentration of chemical detergents that are much more harmful. In addition, the biosurfactants are compatible with the variety of enzymes that are used in the “bio”-detergents that are often inactivated by the chemical detergents. Bioemulsifiers also can be used as substitutes for chlorinated solvents for cleaning of electronic boards and cutting devices and delicate instruments that can be damaged by standard detergents.

Bioemulsifiers are potentially useful in agriculture, especially in various formulations of herbicides and pesticides. The active compounds in these formulations are hydrophobic, and emulsifiers are required for dispersing them in the aqueous solutions. One example is the use of bioemulsifiers—probably glycolipopeptides—produced by strains of *Bacillus* for emulsifying immiscible organophosphorus pesticides (Patel and Gopinathan 1986).

The class of polymeric (high-molecular-weight) bioemulsifiers offers additional advantages. These emulsifiers coat the droplets of oil, thereby forming very stable emulsions that never coalesce. This property is especially useful for making oil-in-water emulsions for cosmetics and for food (such as salad dressings; Klekner and Kosaric 1993; Shepherd et al. 1995). In dairy products (soft cheeses and ice creams), the addition of polymeric emulsifiers improves the texture and creaminess. This quality is of special value for low-fat products. Because polymeric emulsifiers adhere to the oil, they concentrate in the oil–water interphase and stay with the oil when the water is removed. Consequently, the emulsions are stable even in very dilute solutions. In addition, the emulsifier concentrations in the water are very low, allowing the water to be recycled. These properties are of special importance for various applications in the textile or paper industries (Rosenberg et al. 1989).

At present, the cost of production and insufficient experience in applications limit the use of bioemulsifiers. However, inasmuch as awareness of water quality and environmental conservation is increasing and demand for natural products is expanding, it appears inevitable that the high-quality, microbially produced bioemulsifiers will replace the currently used chemical emulsifiers in many of the applications outlined above.

References

- Abraham WR, Meyer H, Yakimov M (1998) Novel glycine containing glucolipids from the alkane using bacterium *Alcanivorax borkumensis*. *Biochim Biophys Acta* 1393(1):57–62
- Appaiah AKA, Karanth NGK (1991) Insecticide specific emulsifier production by hexachlorocyclohexane-utilizing *Pseudomonas tralucida* Ptm+ strain. *Biotechnol Lett* 13:371–374
- Arima K, Kahinuma A, Tamura G (1968) Surfactin, a crystalline peptide lipid surfactant produced by *Bacillus subtilis*: isolation, characterization and its inhibition of fibrin clot formation. *Biochem Biophys Res Commun* 31:488–494
- Arino S, Marchal R, Vandecasteele JP (1996) Identification and production of a rhamnolipidic biosurfactant by a *Pseudomonas* species. *Appl Microbiol Biotechnol* 45(1–2):162–168
- Arino S, Marchal R, Vandecasteele JP (1998) Involvement of a rhamnolipid-producing strain of *Pseudomonas aeruginosa* in the degradation of polycyclic aromatic hydrocarbons by a bacterial community. *J Appl Microbiol* 84:769–776
- Ashtaputre AA, Shah AK (1995) Emulsifying property of a viscous exopolysaccharide from *Sphingomonas paucimobilis*. *World J Microbiol Biotechnol* 11:219–222
- Banat IM (1995) Biosurfactants production and possible use in microbial enhanced oil recovery and oil pollution remediation: a review. *Biosource Technol* 51:1–12
- Barkay T, Navon-Venezia S, Ron E, Rosenberg E (1999) Enhancement of solubilization and biodegradation of polyaromatic hydrocarbons by the bioemulsifier alasan. *Appl Environ Microbiol* 65:2697–2702
- Beebe JL, Umbreit WW (1971) Extracellular lipid of *Thiobacillus thiooxidans*. *J Bacteriol* 108:612–615
- Belsky I, Gutnick DL, Rosenberg E (1979) Emulsifier of *Arthrobacter* RAG-1: determination of emulsifier-bound fatty acids. *FEBS Lett* 101:175–178
- Bernheimer AW, Avigad LS (1970) Nature and properties of a cytological agent produced by *Bacillus subtilis*. *J Gen Microbiol* 61:361–369
- Bohringer J, Fischer D, Mosler G, Hengge-Aronis R (1995) UDP-glucose is a potential intracellular signal molecule in the control of expression of sigma S and sigma S-dependent genes in *Escherichia coli*. *J Bacteriol* 177:413–422
- Bonilla M, Olivaro C, Corona M, Vazquez A, Soubes M (2005) Production and characterization of a new bioemulsifier from *Pseudomonas putida* ML2. *J Appl Microbiol* 98:456–463
- Borchert S, Stachelhaus T, Marahiel MA (1994) Induction of surfactin production in *Bacillus subtilis* by gsp, a gene located upstream of the gramicidin S operon in *Bacillus brevis*. *J Bacteriol* 176:2458–2462
- Brint JM, Ohman DE (1995) Synthesis of multiple exoproducts in *Pseudomonas aeruginosa* is under the control of RhlR-RhlI, another set of regulators in strain PAO1 with homology to the autoinducer-responsive LuxR-LuxI family. *J Bacteriol* 177:7155–7163
- Bruheim P, Bredholt H, Eimhjellen K (1997) Bacterial degradation of emulsified crude oil and the effect of various surfactants. *Can J Microbiol* 43(1):17–22
- Bunster L, Fokkema NJ, Shippers B (1989) Effect of surface-active *Pseudomonas* spp. on leaf wettability. *Appl Environ Microbiol* 55:1434–1435
- Burd G, Ward OP (1996) Physicochemical properties of PM-factor, a surface-active agent produced by *Pseudomonas marginalis*. *Can J Microbiol* 42:243–252
- Calvo C, Martinez-Checa F, Mota A, Bejar V, Quesada E (1998) Effect of cations, pH and sulfate content on the viscosity and emulsifying activity on the *Halomonas eurihalina*. *J Ind Microbiol Biotechnol* 20:205–209
- Cameron DR, Cooper DG, Neufeld RJ (1988) The mannoprotein of *Saccharomyces cerevisiae* is an effective bioemulsifier. *Appl Environ Microbiol* 54:1420–1425
- Campos-Garcia J, Caro AD, Najera R, Miller-Maier RM, Al-Tahhan RA, Soberon-Chavez D (1998) The *Pseudomonas aeruginosa* rhlG gene encodes an NADPH-dependent beta-ketoacyl reductase which is specifically involved in rhamnolipid synthesis. *J Bacteriol* 180:4442–4451
- Cirigliano MC, Carman GM (1984) Purification and characterization of liposan, a bioemulsifier from *Candida lipolytica*. *Appl Environ Microbiol* 50:846–850
- Cooper DG, Paddock DA (1983) *Torulopsis petrophilum* and surface activity. *Appl Environ Microbiol* 46:1426–1429
- Cooper DG, Zajic JE (1980) Surface active compounds from microorganisms. *Adv Appl Microbiol* 26:229–253
- Cooper DG, MacDonald CR, Duff SJB, Kosaric N (1981) Enhanced production of surfactin of *B subtilis* by continuous product removal and metal cation additions. *Appl Environ Microbiol* 42:408–412
- Cooper DG, Liss SN, Longay R, Zajic JE (1989) Surface activities of *Mycobacterium* and *Pseudomonas*. *J Ferment Technol* 59:97–101
- Cosby WM, Vollenbroich D, Lee OH, Zuber P (1998) Altered srf expression in *Bacillus subtilis* resulting from changes in culture pH is dependent on the Spo0K oligopeptide permease and the ComQX system of extracellular control. *J Bacteriol* 180:1438–1445
- Cosmina P, Rodriguez F, de Ferra F, Grandi G, Perego M, Venema G, van Sinderen D (1993) Sequence and analysis of the genetic locus responsible for surfactin synthesis in *Bacillus subtilis*. *Mol Microbiol* 8:21–31
- Cutler AJ, Light RJ (1979) Regulation of hydroxydocosanoic and sophorose production in *Candida bogoriensis* by the level of glucose and yeast extract in the growth medium. *J Biol Chem* 254:1944–1950
- Dahan O (1998) Isolation and characterization of alasan mutants in *Acinetobacter radioresistens*. MSc, Thesis, Tel Aviv University
- Davila AM, Marchal R, Vandecasteele JP (1997) Sophorose lipid fermentation with differentiated substrate supply for growth and production phases. *Appl Microbiol Biotechnol* 47:496–501
- De Acevedo GT, McInerney MJ (1996) Emulsifying activity in thermophilic and extremely thermophilic microorganisms. *J Ind Microbiol* 16:17–22
- Desai J, Banat I (1997) Microbial production of surfactants and their commercial potential. *Microbiol Mol Biol Rev* 61:47–48
- Deziel E, Paquette G, Villemur R, Lepine F, Bisailon JG (1996) Biosurfactant production by a soil *Pseudomonas* strain growing on polycyclic aromatic hydrocarbons. *Appl Environ Microbiol* 62(6):1908–1912
- Espuny MJ, Egado S, Rodon I, Manresa A, Mercade ME (1996) Nutritional requirements of a biosurfactant producing strain *Rhodococcus* s p 51 T7. *Biotechnol Lett* 18:521–526
- Fabret C, Quentin Y, Guiseppi A, Busuttill J, Haiech J, Denizot F (1995) Analysis of errors in finished DNA sequences: the surfactin operon of *Bacillus subtilis* as an example. *Microbiology* 141:345–350
- Fattom A, Shilo M (1985) Production of emulcyan by *Phormidium* J-1: its function and activity. *FEMS Microbiol Ecol* 1:1–7
- Fiebig R, Schulze D, Chung JC, Lee ST (1997) Biodegradation of polychlorinated biphenyls (PCBs) in the presence of a bioemulsifier produced on sunflower oil. *Biodegradation* 8:67–75
- Fiechter A (1992) Biosurfactants: moving towards industrial application. *Trends Biotechnol* 10:208–217
- Fraenkel DG (1992) Genetics and intermediary metabolism. *Annu Rev Genet* 26:159–177
- Galli G, Rodriguez F, Cosmina P, Pratesi C, Nogarotto R, de Ferra F, Grandi G (1994) Characterization of the surfactin synthetase multi-enzyme complex. *Biochim Biophys Acta* 1205:19–28
- Goldenberg-Dvir V (1998) A new bioemulsifier produced by the oil-degrading *Acinetobacter junii* V-26. MSc, thesis, Tel Aviv University
- Goldman S, Shabtai Y, Rubinovitz C, Rosenberg E, Gutnick DL (1982) Emulsan in *Acinetobacter calcoaceticus* RAG-1: distribution of cell-free and cell-associated cross-reacting materials. *Appl Environ Microbiol* 44:165–170
- Golyshin PN, Lang S, Moore ER, Abraham WR, Lunsdorf H, Timmis KJ (1998) *Alcanivorax borkumensis* gen. nov., sp. nov., a new hydrocarbon-degrading and surfactant-producing marine bacterium. *Int J Syst Bacteriol* 48(2):339–348
- Grau A, Gomez Fernandez JC, Peypoux F, Ortiz A (1999) A study on the interactions of surfactin with phospholipid vesicles. *Biochim Biophys Acta* 1418:307–319
- Grossman AD (1995) Genetic networks controlling the initiation of sporulation and the development of genetic competence in *Bacillus subtilis*. *Annu Rev Genet* 29:477–508
- Guerra-Santos LH, Kappeli O, Fiechter A (1986) Dependence of *Pseudomonas aeruginosa* continuous culture biosurfactant production on nutritional and environmental factors. *Appl Microbiol Biotechnol* 24:443–448

- Gunjar M, Khire JM, Khan MI (1995) Bioemulsifier production by *Bacillus stearothermophilus* VR8 isolate. *Lett Appl Microbiol* 21:83–86
- Gutierrez T, Mulloy B, Bavington C, Black K, Green DH (2007) Partial purification and chemical characterization of a glycoprotein (putative hydrocolloid) emulsifier produced by a marine bacterium *Antarctobacter*. *Appl Microbiol Biotechnol* 76:1017–1026
- Hauser G, Karnovsky ML (1954) Studies on the production of glycolipid by *Pseudomonas aeruginosa*. *J Bacteriol* 68:645–654
- Hisatsuka K, Nakahara T, Sano N, Yamada K (1971) Formation of rhamnolipid by *Pseudomonas aeruginosa* and its function in hydrocarbon fermentation. *Agric Biol Chem* 35:686–692
- Horowitz S, Griffin WM (1991) Structural analysis of *Bacillus licheniformis* 86 surfactant. *J Ind Microbiol* 7:45–52
- Inoue S, Itoh S (1982) Sophorolipids from *Torulopsis bombicola* as microbial surfactants in alkane fermentation. *Biotechnol Lett* 4:308–312
- Isoda H, Shinmoto H, Kitamoto D, Matsumura M, Nakahara T (1997) Differentiation of human promyelocytic leukemia cell line HL60 by microbial extracellular glycolipids. *Lipids* 32:263–271
- Itoh S, Inoue S (1982) Sophorolipids from *Torulopsis bombicola* as microbial surfactants in alkane fermentations. *Appl Environ Microbiol* 43:1278–1283
- Itoh S, Suzuki T (1972) Effect of rhamnolipids on growth of *Pseudomonas aeruginosa* mutant deficient in *n*-paraffin-utilizing ability. *Agric Biol Chem* 36:1233–1235
- Kaeppli O, Finnerty WR (1979) Partition of alkane by an extracellular vesicle derived from hexadecane-grown *Acinetobacter*. *J Bacteriol* 140:707–712
- Kaeppli O, Finnerty WR (1980) Characteristics of hexadecane partition by the growth medium of *Acinetobacter* sp. *Biotechnol Bioeng* 22:495–501
- Kaeppli O, Walther P, Mueller M, Fiechter A (1984) Structure of cell surface of the yeast *Candida tropicalis* and its relation to hydrocarbon transport. *Arch Microbiol* 138:279–282
- Kaplan N, Rosenberg E (1982) Exopolysaccharide distribution and bioemulsifier production in *Acinetobacter calcoaceticus* BD4 and BD413. *Appl Environ Microbiol* 44:1335–1341
- Kaplan N, Jann B, Jann K (1985) Structural studies on the capsular polysaccharide of *Acinetobacter calcoaceticus* BD4. *Eur J Biochem* 152:453–458
- Kaplan N, Zosim Z, Rosenberg E (1987) *Acinetobacter calcoaceticus* BD4 emulsan: reconstitution of emulsifying activity with pure polysaccharide and protein. *Appl Environ Microbiol* 53:440–446
- Katz E, Demain AL (1977) The peptide antibiotics of *Bacillus*: chemistry, biogenesis and possible functions. *Bacteriol Rev* 41:449–458
- Kelkar DS, Kumar AR, Zinjarde SS (2007) Hydrocarbon emulsification and enhanced crude oil degradation by lauroyl glucose ester. *Bioresour Technol* 98:1505–1508
- Kim JS, Powalla M, Lang S, Wagner F, Lunsdorf H, Wray V (1990) Microbial glycolipid production under nitrogen limitation and resting cell conditions. *J Biotechnol* 13:257–266
- Klekner V, Kosaric N (1993) Biosurfactants for cosmetics. In: Kosaric N (ed) *Biosurfactants: production, properties, applications*, vol 48, Surfactant science series. Marcel Dekker, New York, pp 329–372
- Koch AK, Kaeppli O, Fiechter A, Reiser J (1991) Hydrocarbon assimilation and biosurfactant production in *Pseudomonas aeruginosa* mutants. *J Bacteriol* 173:4212–4219
- Konz D, Doekel A, Marahiel MA (1999) Molecular and biochemical characterization of the protein template controlling biosynthesis of the lipopeptide lichenysin. *J Bacteriol* 181:133–140
- Krauss EM, Chan SI (1983) Complexation and phase transfer of nucleotides by gramicidin S. *Biochemistry* 22:4280–4285
- Kretschmer A, Bock H, Wagner F (1982) Chemical and physical characterization of interfacial-active lipids from *Rhodococcus erythropolis* grown on *n*-alkane. *Appl Environ Microbiol* 44:864–870
- Lambalot RH, Gehring AM, Flugel RS, Zuber P, LaCelle M, Marahiel MA, Reid R, Khosla C, Walsh CT (1996) A new enzyme superfamily—the phosphopantetheinyl transferases. *Chem Biol* 3:923–936
- Lang S, Philip JC (1998) Surface active lipids in *Rhodococci*. *Anton Leeuw Int* 74:59–70
- Lang S, Wagner F (1987) Structure and properties of biosurfactants. In: Kosaric N, Cairns WL, Gray NCC (eds) *Biosurfactants and biotechnology*, vol 25, Surfactant science series. Marcel Dekker, New York, pp 21–47
- Lang S, Wullbrandt D (1999) Rhamnose lipids-biosynthesis, microbial production and application potential. *Appl Microbiol Biotechnol* 51:22–32
- Latifi A, Winson MK, Foglino M, Bycroft BW, Stewart GS, Lazdunski A, Williams P (1995) Multiple homologues of LuxR and LuxI control expression of virulence determinants and secondary metabolites through quorum sensing in *Pseudomonas aeruginosa* PAO1. *Mol Microbiol* 17:333–343
- Latifi A, Foglino M, Tanaka K, Williams P, Lazdunski A (1996) A hierarchical quorum-sensing cascade in *Pseudomonas aeruginosa* links the transcriptional activators LasR and RhlR (VsmR) to expression of the stationary-phase sigma factor RpoS. *Mol Microbiol* 21:1137–1146
- Lazizzera BA, Kurtser IG, McQuade RS, Grossman AD (1999) An autoregulatory circuit affecting peptide signaling in *Bacillus subtilis*. *J Bacteriol* 181:5193–5200
- Li ZY, Lang S, Wagner F, Witte L, Wray V (1984) Formation and identification of interfacial-active glycolipids from resting microbial cells of *Arthrobacter* sp. and potential use in tertiary oil recovery. *Appl Environ Microbiol* 48:610–617
- Lin SC (1996) Biosurfactants: recent advances. *J Chem Technol Biotechnol* 66(2):109–120
- Lin SC, Minton MA, Sharma MM, Georgiou G (1994) Structural and immunological characterization of a biosurfactant produced by *Bacillus licheniformis* JF-2. *Appl Environ Microbiol* 60:31–38
- Lindum PW, Anthoni U, Christophersen C, Eberl L, Molin S, Givskov M (1998) N-Acyl-L-homoserine lactone autoinducers control production of an extracellular lipopeptide biosurfactant required for swarming motility of *Serratia liquefaciens* MG1. *J Bacteriol* 180:6384–6388
- Liu L, Nakano MM, Lee OH, Zuber P (1996) Plasmid-amplified comS enhances genetic competence and suppresses sinR in *Bacillus subtilis*. *J Bacteriol* 178:5144–5152
- Liu X, Ren B, Chen M, Wang H, Kokare CR, Zhou X, Wang J, Dai H, Song F, Liu M, Wang J, Wang S, Zhang L (2010) Production and characterization of a group of bioemulsifiers from the marine *Bacillus velezensis* strain H3. *Appl Microbiol Biotechnol* 5:1881–1893
- Luttinger A, Hahn J, Dubnau D (1996) Polynucleotide phosphorylase is necessary for competence development in *Bacillus subtilis*. *Mol Microbiol* 19:343–356
- MacDonald CR, Cooper DG, Zajic JE (1981) Surface-active lipids from *Nocardia erythropolis* grown on hydrocarbons. *Appl Environ Microbiol* 41:117–123
- Makkar RS, Cameotra SS (1997) Biosurfactant production by a thermophilic *Bacillus subtilis* strain. *J Ind Microbiol Biotechnol* 18(1):37–42
- Maneerat S, Bamba T, Harada K, Kobayashi A, Yamada H, Kawai F (2006) A novel crude oil emulsifier excreted in the culture supernatant of a marine bacterium, *Myroides* sp. strain SM1. *Appl Microbiol Biotechnol* 70:254–259
- Marahiel MA (1997) Protein templates for the biosynthesis of peptide antibiotics. *Chem Biol* 4:4561–4567
- Marahiel MA, Nakano MM, Zuber P (1993) Regulation of peptide antibiotic production in *Bacillus*. *Mol Microbiol* 7:631–636
- Marin M, Pedregosa A, Laborda F (1996) Emulsifier production and microscopical study of emulsions and biofilms formed by the hydrocarbon-utilizing bacteria *Acinetobacter calcoaceticus* MM5. *Appl Microbiol Biotechnol* 44:660–667
- Matsuyama T, Sogawa M, Yano I (1991) Direct colony thin-layer chromatography and rapid characterization of *Serratia marcescens* mutants defective in production of wetting agents. *Appl Environ Microbiol* 53:1186–1188
- Menkhaus M, Ullrich C, Kluge B, Vater J, Vollenbroich D, Kamp RM (1993) Structural and functional organization of the surfactin synthetase multienzyme system. *J Biol Chem* 268:7678–7684
- Miller RM, Zhang Y (1997) Measurement of biosurfactant-enhanced solubilization and biodegradation of hydrocarbons. *Method Biotechnol* 2:59–66
- Nakano MM, Magnuson R, Myers A, Curry J, Grossman AD, Zuber P (1991) srfA is an operon required for surfactin production, competence development, and efficient sporulation in *Bacillus subtilis*. *J Bacteriol* 173:1770–1778
- Nakano MM, Corbel N, Besson J, Zuber P (1992) Isolation and characterization of sfp: a gene that functions in the production of the lipopeptide biosurfactant, surfactin, in *Bacillus subtilis*. *Mol Gen Genet* 232:313–321

- Nakayama S, Takahashi S, Hirai M, Shoda M (1997) Isolation of new variants of surfactin by a recombinant *Bacillus subtilis*. *Appl Microbiol Biotechnol* 48:80–82
- Navon-Venezia S, Zosim Z, Gottlieb A, Legmann R, Carmeli S, Ron EZ, Rosenberg E (1995) Alasan, a new bioemulsifier from *Acinetobacter radioresistens*. *Appl Environ Microbiol* 61:3240–3244
- Navon-Venezia S, Banin E, Ron EZ, Rosenberg E (1998) The bioemulsifier alasan: role of protein in maintaining structure and activity. *Appl Microbiol Biotechnol* 49:382–384
- Neu TR (1996) Significance of bacterial surface-active compounds in interaction of bacteria with interfaces. *Microbiol Rev* 60:151–166
- Neu TR, Poralla K (1990) Emulsifying agent from bacteria isolated during screening for cells with hydrophobic surfaces. *Appl Microbiol Biotechnol* 32:521–525
- Neu TR, Dengler T, Jann B, Poralla K (1992) Structural studies of an emulsion-stabilizing exopolysaccharide produced by an adhesive, hydrophobic *Rhodococcus* strain. *J Gen Microbiol* 138:2531–2537
- Neufeld RJ, Zajic JE (1984) The surface activity of *Acinetobacter calcoaceticus* sp. 2CA2. *Biotechnol Bioeng* 26:1108–1114
- Ochsner UA, Reiser J (1995) Autoinducer-mediated regulation of rhamnolipid biosurfactant synthesis in *Pseudomonas aeruginosa*. *Proc Natl Acad Sci USA* 92:6424–6428
- Ochsner UA, Koch AK, Fiechter A, Reiser J (1994) Isolation and characterization of a regulatory gene affecting rhamnolipid biosurfactant synthesis in *Pseudomonas aeruginosa*. *J Bacteriol* 176:2044–2054
- Parra JL, Guinea J, Manresa MR, Mercade ME, Comelles F, Bosch MP (1989) Chemical characterization and physico-chemical behaviour of biosurfactants. *J Am Oil Chem Soc* 66:141–145
- Patel MN, Gopinathan KP (1986) Lysozyme-sensitive bioemulsifier for immiscible organophosphorus pesticides. *Appl Environ Microbiol* 52:1224–1226
- Pearson JP, Pesci EC, Iglewski BH (1997) Roles of *Pseudomonas aeruginosa* las and rhl quorum-sensing systems in control of elastase and rhamnolipid biosynthesis genes. *J Bacteriol* 179:5756–5767
- Persson A, Oesterberg E, Dostalek M (1988) Biosurfactant production by *Pseudomonas fluorescens* 378: growth and product characteristics. *Appl Microbiol Biotechnol* 29:1–4
- Pesci EC, Pearson JP, Seed PC, Iglewski BH (1997) Regulation of las and rhl quorum sensing in *Pseudomonas aeruginosa*. *J Bacteriol* 179:3127–3132
- Peypoux F, Bonmatin JM, Wallach J (1999) Recent trends in the biochemistry of surfactin. *Appl Microbiol Biotechnol* 51:553–563
- Pruthi V, Cameotra SS (1997) Production of a biosurfactant exhibiting excellent emulsification and surface active properties by *Serratia marcescens*. *World J Microbiol Biotechnol* 13(1):133–135
- Rapp P, Bock H, Wray V, Wagner F (1979) Formation, isolation and characterization of trehalose dimycolates from *Rhodococcus erythropolis* grown on n-alkanes. *J Gen Microbiol* 115:491–503
- Rau U, Manzke C, Wagner F (1996) Influence of substrate supply on the production of sophorose lipids by *Candida bombicola* ATCC 22214. *Biotechnol Lett* 18:149–154
- Rehm HJ, Reiff I (1981) Mechanisms and occurrence of microbial oxidation of long-alkanes. *Adv Biochem Eng* 19:173–181
- Rendell NB, Taylor GW, Somerville M, Todd H, Wilson R, Cole J (1990) Characterization of *Pseudomonas rhamnolipids*. *Biochim Biophys Acta* 1045:189–193
- Richter M, Willey M, Suessmuth R, Jung G, Fiedler HP (1998) Streptofactin, a novel biosurfactant with aerial mycelium inducing activity from *Streptomyces tendae* Tue 901/8c. *FEMS Microbiol Lett* 163(2):165–171
- Ristau E, Wagner F (1983) Formation of novel anionic trehalose-tetraesters from *Rhodococcus erythropolis* under growth limiting conditions. *Biotechnol Lett* 5:95–100
- Robinson K, Ghosh M, Shi Z (1996) Mineralization enhancement of non-aqueous phase and soil-bound PCB using biosurfactant. *Water Sci Technol* 34:303–309
- Ron E, Rosenberg E (2010a) Role of biosurfactants. In: Timmis KN (ed) *Handbook of hydrocarbon and lipid microbiology*. Springer, Heidelberg
- Ron E, Rosenberg E (2010b) Protein emulsifiers. In: Timmis KN (ed) *Handbook of hydrocarbon and lipid microbiology*. Springer, Heidelberg
- Rosenberg E (1993) Exploiting microbial growth on hydrocarbon: new markets. *Trends Biotechnol* 11:419–424
- Rosenberg E, Kaplan N (1987) Surface-active properties of *Acinetobacter expolysaccharides*. In: Inouye M (ed) *Bacteria outer membranes as model systems*. Wiley, New York, pp 311–342
- Rosenberg E, Ron EZ (1996) Bioremediation of petroleum contamination. In: Crawford RL, Crawford DL (eds) *Bioremediation: principles and applications*. Cambridge University Press, Cambridge, MA, pp 100–124
- Rosenberg E, Ron EZ (1997) Bioemulsans: microbial polymeric emulsifiers. *Curr Opin Biotechnol* 8:313–316
- Rosenberg E, Ron EZ (1998) Surface active polymers from the genus *Acinetobacter*. In: Kaplan DL (ed) *Biopolymers from renewable resources*. Springer, Berlin, pp 281–291
- Rosenberg E, Ron EZ (1999) High and low molecular mass microbial surfactants. *Appl Microbiol Biotechnol* 52:154–162
- Rosenberg E, Perry A, Gibson DT, Gutnick D (1979a) Emulsifier of *Arthrobacter* RAG-1: specificity of hydrocarbon substrate. *Appl Environ Microbiol* 37:409–413
- Rosenberg E, Zuckerberg A, Rubinovitz C, Gutnick DL (1979b) Emulsifier of *Arthrobacter* RAG-1: isolation and emulsifying properties. *Appl Environ Microbiol* 37:402–408
- Rosenberg E, Gottlieb A, Rosenberg M (1983) Inhibition of bacterial adherence to hydrocarbons and epithelial cells by emulsan. *Infect Immun* 39:1024–1028
- Rosenberg E, Rubinovitz C, Gottlieb A, Rosenhak S, Ron EZ (1988a) Production of biodispersan by *Acinetobacter calcoaceticus* A2. *Appl Environ Microbiol* 54:317–322
- Rosenberg E, Rubinovitz C, Legmann R, Ron EZ (1988b) Purification and chemical properties of *Acinetobacter calcoaceticus* A2 biodispersan. *Appl Environ Microbiol* 54:323–326
- Rosenberg E, Schwartz Z, Tenenbaum A, Rubinovitz C, Legmann R, Ron EZ (1989) A microbial polymer that changes the surface properties of limestone: effect of biodispersan in grinding limestone and making paper. *J Dispers Sci Technol* 10:241–250
- Rosenberg E, Barkay T, Navon-Venezia S, Ron EZ (1999) Role of *Acinetobacter* bioemulsans in petroleum degradation. In: Fass R et al (eds) *Novel approaches for bioremediation of organic pollution*. Kluwer/Plenum, New York, pp 171–180
- Rubinowitz C, Gutnick DL, Rosenberg E (1982) Emulsan production by *Acinetobacter calcoaceticus* in the presence of chloramphenicol. *J Bacteriol* 152:126–132
- Sapir S (1998) Genes involved in growth of *Acinetobacter junii* strain V26 on hexadecane. MSc, Thesis, Tel Aviv University
- Sar N, Rosenberg E (1983) Emulsifier production by *Acinetobacter calcoaceticus* strains. *Curr Microbiol* 9:309–314
- Sekelsky AM, Shreve GS (1999) Kinetic model of biosurfactant-enhanced hexadecane biodegradation by *Pseudomonas aeruginosa*. *Biotechnol Bioeng* 63:401–409
- Shepherd R, Rocky J, Sutherland IW, Roller S (1995) Novel bioemulsifiers from microorganisms for use in foods. *J Biotechnol* 40:207–217
- Sim L, Ward OP, Li ZY (1997) Production and characterization of a biosurfactant isolated from *Pseudomonas aeruginosa* UW-1. *J Ind Microbiol Biol* 19:232–238
- Solomon JM, Magnuson R, Srivastava A, Grossman AD (1995) Convergent sensing pathways mediate response to two extracellular competence factors in *Bacillus subtilis*. *Genes Dev* 9:547–558
- Stark M (1996) Analysis of the exopolysaccharide gene cluster from *Acinetobacter calcoaceticus* BD4. PhD thesis, Tel Aviv University
- Sullivan ER (1998) Molecular genetics of biosurfactant production. *Curr Opin Biotechnol* 9:263–269
- Suzuki T, Hayashi K, Fujikawa K, Tsukamoto K (1965) The chemical structure of polymyxin E the identities of polymyxin E1 with colistin A and polymyxin E2 with colistin. *J Biol Chem* 57:226–227
- Suzuki T, Tanaka K, Matsubara J, Kimoshita S (1969) Trehalose lipid and branched-hydroxy fatty acids formed by bacteria grown on n-alkanes. *Agric Biol Chem* 33:1619–1625

- Taylor WH, Juni E (1961) Pathways for biosynthesis of a bacterial capsular polysaccharide. I. Characterization of the organism and polysaccharide. *J Bacteriol* 81:688–693
- Toren A, Orr E, Paitan Y, Ron EZ, Rosenberg E (2002a) The active component of the bioemulsifier alasin from *Acinetobacter radioresistens* KA53 is an OmpA-like protein. *J Bacteriol* 184:165–170
- Toren A, Ron EZ, Bekerman R, Rosenberg E (2002b) Solubilization of polyaromatic hydrocarbons by recombinant bioemulsifier AlnA. *Appl Microbiol Biotechnol* 59:580–584
- Trebbau-de AG, McInerney MJ (1996) Emulsifying activity in thermophilic and extremely thermophilic microorganisms. *J Ind Microbiol* 16:1–7
- Van Delden C, Pesci EC, Pearson JP, Iglewski BH (1998) Starvation selection restores elastase and rhamnolipid production in a *Pseudomonas aeruginosa* quorum-sensing mutant. *Infect Immun* 66:4499–4502
- van Loosdrecht MCM, Lyklema J, Norde W, Zehnder AJB (1990) Influence of interfaces on microbial activity. *Microbiol Rev* 54:75–87
- Volkering F, Breure A, Rulkens W (1997) Microbiological aspects of surfactant use for biological soil remediation. *Biodegradation* 8:401–417
- Wagner F, Behrendt V, Bock H, Kretschmer A, Lang S, Syltatk C (1983) Production and chemical characterization of surfactants from *Rhodococcus erythropolis* and *Pseudomonas* sp. MUB grown on hydrocarbons. In: Zajic JE et al (eds) *Microbial enhanced oil recovery*. Pennwell, Tulsa, pp 55–60
- Wang SD, Wand DIC (1990) Mechanisms for biopolymer accumulation in immobilized *Acinetobacter calcoaceticus* system. *Biotechnol Bioeng* 36:402–410
- Wei YH, Chu IM (1998) Enhancement of surfactin production in iron-enriched media by *Bacillus subtilis* ATCC 21332. *Enzyme Microb Technol* 22:724–728
- Yakimov MM, Golyshin PN (1997) ComA-dependent transcriptional activation of lichenysin A synthetase promoter in *Bacillus subtilis* cells. *Biotechnol Prog* 13:757–761
- Yakimov MM, Timmis KN, Wray V, Fredrickson HL (1995) Characterization of a new lipopeptide surfactant produced by thermotolerant and halotolerant subsurface *Bacillus licheniformis* BAS50. *Appl Environ Microbiol* 61:1706–1713
- Yakimov MM, Kroger A, Slepak TN, Giuliano L, Timmis KN, Golyshin PN (1998) A putative lichenysin A synthetase operon in *Bacillus licheniformis*: initial characterization. *Biochim Biophys Acta* 1399:141–153
- Zhang Y, Miller RM (1994) Effect of a *Pseudomonas rhamnolipid* biosurfactant on cell hydrophobicity and biodegradation of octadecane. *Appl Environ Microbiol* 60:2101–2106
- Zhang Y, Miller RM (1995) Effect of rhamnolipid (biosurfactant) structure on solubilization and biodegradation of n-alkanes. *Appl Environ Microbiol* 61(6):2247–2251
- Zhou QH, Kosaric N (1995) Utilization of canola oil and lactose to produce biosurfactant with *Candida bombicola*. *J Am Oil Chem Soc* 72:67–71

11 Bioremediation

Ronald L. Crawford¹ · Eugene Rosenberg²

¹Environmental Biotechnology Institute, University of Idaho, Moscow, ID, USA

²Department of Molecular Microbiology and Biotechnology, Tel Aviv University, Tel Aviv, Israel

Introduction	295
Bioremediation	295
Areas of Research and Development	296
Bioreactors	296
Biofiltration	297
Air Sparging	297
Bioventing	299
Landfarming	300
Biopiles	300
Composting	301
Intrinsic Bioremediation	302
Phytoremediation	302
White-Rot Fungi	303
Bioremediation of Oil Spills at Sea	304
Limitations of Bioremediation	304

Abstract

Bioremediation is the use of biological systems, usually microorganisms, to treat polluted soils and water. Optimization of bioremediation processes generally requires the addition of inorganic materials (biostimulation), such as utilizable sources of nitrogen, phosphorus, and oxygen. Generally, appropriate microorganisms are present in the polluted material and do not have to be added. However, occasionally natural or genetically engineered microbes may need to be added (bioaugmentation). Treatments can be either *ex situ* or *in situ*. The technology can involve aerobic and/or anaerobic bioreactors, biofiltration, air sparging, bioventing, composting, landfarming, and biopiles. Intrinsic remediation refers to the combined effects of all natural processes in contaminated environments that reduce the mobility, mass, and risks of pollutants. The limitations of bioremediation are discussed, including the treatment of petroleum pollution in the sea.

Introduction

As a result of human ignorance in the safe use of chemicals, carelessness in manufacture of synthetic compounds, occasional accidents, and improper disposal of chemical wastes, toxic

anthropogenic chemicals have become ubiquitous contaminants of soils and waters worldwide. For example, the recent Deepwater Horizon oil spill (also referred to as the BP oil spill) resulted in the release of more than 700,000 t of crude oil into the Gulf of Mexico. Chemical pollutants include thousands of individual molecules. They are found in the environment sometimes individually but more often as complex mixtures. Many are overtly toxic (e.g., the metal mercury or the herbicide dinoseb). Many more are chronic toxins, some of them carcinogens (e.g., organic polynuclear aromatic hydrocarbons or metals such as arsenic). They are derived from sources such as petroleum, synthetic organic chemicals, mining activities, and natural or man-made radionuclides. Governments now regulate the use and disposal of toxic chemicals more rigorously than in the past. However, the legacy of environmental damage from previous decades of improper practice now requires cleanup to mitigate, insofar as possible, hazards to human health and the environment.

Traditional environmental cleanup methods include approaches such as excavation and incineration of contaminated soil or pumping and aboveground treatment of groundwater. These techniques are both expensive and politically unpopular. Affordable, innovative technologies are needed by the environmental restoration industry. Bioremediation is such a technology.

Bioremediation

Bioremediation employs living organisms, most often microorganisms, plants, or both, or products produced from living organisms to degrade, detoxify, or sequester toxic chemicals present in natural waters and soils. Bioremediation can be adapted for use to treat soil, sediment, sludge, water, or even air. Treatments can be either *ex situ* or *in situ*. *Ex situ* procedures involve removal of contaminated materials from a polluted site prior to treatment in another location. *In situ* approaches treat contaminants in place without moving them to a treatment facility. Bioremediation sometimes can be accelerated or, in very difficult circumstances, even made possible by augmenting natural systems with exogenous biological materials. This process is called *bioaugmentation*. Bioaugmentation usually involves the use of natural microorganisms or plants grown to large numbers in fermenters or greenhouses and can include the use of genetically engineered microorganisms (GEMs) or plants developed specifically for the purpose. More often bioremediation can be accomplished most efficiently by simply stimulating natural, indigenous,

contaminant-transforming microbial or plant populations by providing them the necessary nutrients, environmental conditions, or both needed for growth and metabolism. This process is called *biostimulation* (Ron and Rosenberg 2009). Recently, it has been shown that water-insoluble fertilizers, such as uric acid and urea-formaldehyde polymers, can be effective in stimulating biodegradation of hydrocarbons in the marine environment (Koren et al. 2003; Knezevich et al. 2006). Yet another bioremediation option is called *intrinsic bioremediation*. This encompasses natural microbial processes that occur without human intervention (self-restoration). Finally, abiotic processes sometimes can be used in combination with biotic processes to degrade particularly recalcitrant molecules. Examples of abiotic catalysts that may enhance biodegradative processes include ultraviolet light, inorganic reductants, and Fenton reagent (iron and hydrogen peroxide). The bioremediation industry has developed many novel approaches for biostimulation, bioaugmentation, combined abiotic/biotic processes, and for monitoring and quantifying intrinsic bioremediation.

Areas of Research and Development

Bioreactors

Bioreactors are vessels of various configurations and arrangements (Admassu and Korus 1996) that contain degradative microbes and possibly other catalytic agents that function cooperatively with microbial systems. They are a common means of ex situ treatment of contaminated soil that has been excavated from a polluted site or groundwater that has been pumped from a polluted aquifer.

A common bioreactor design seen in the field is a vessel containing a slurry of soil and water to which nutrients have been added to stimulate indigenous bacteria. Common nutrient additions include sources of nitrogen, phosphorus, and carbon that support the growth and metabolism of desirable indigenous degradative microorganisms. For example, nitrogen can be added to stimulate the growth of bacteria that grow on hydrocarbon contaminants such as polynuclear aromatic compounds and aromatic compounds derived from creosote (Barbeau et al. 1997; Shuttleworth and Cerniglia 1997). Additions also may include inducer substrates to stimulate particular types of microorganism or microbial activities. For example, biphenyl has been used to stimulate the growth of bacteria able to degrade chlorinated compounds and polychlorinated biphenyls (PCBs; Focht 1997). If appropriate microorganisms are not present to be stimulated, they can be added (Brunsbach and Reineke 1994). *Slurry reactors* can be run aerobically by stirring and mixing in either air or pure oxygen (LaGrega et al. 1994). Alternatively, they can be run anaerobically (anoxic conditions) with the economic advantage that little or no mixing is required (Funk et al. 1995a, b). Slurry-phase reactors can be designed to hold a few thousand or millions of gallons of material (Korus 1997). Aeration systems for aerobic slurry reactors are usually designed to maintain dissolved oxygen concentrations of at least 2.0 mg/l.

Since aeration requires considerable power consumption (pumps, mixers, spargers, etc.) and may require special mechanical designs, it is a major expense for any treatment system. For example, to increase oxygen transfer rates, a system may be sparged with air or pure oxygen introduced through a series of special eductors. At the same time, such systems must minimize air emissions, which often are regulated by state or federal agencies or both. Anaerobic slurry systems usually also require some mixing devices to evenly distribute soil or sediment materials throughout the vessel. However, anoxic processes need not move large amounts of oxygen into the aqueous phase. The choice of anaerobic versus aerobic processes involves, however, more than economic considerations. Some contaminants are degraded poorly or not at all under normal aerobic conditions (e.g., the chlorinated solvent tetrachloroethylene; Wackett 1997). Other contaminants are not degraded under anaerobic conditions, for example, many aromatic compounds (polynuclear aromatic hydrocarbons [PAHs]; Shuttleworth and Cerniglia 1997). Thus, aerobic slurry reactors have been used most commonly to treat soil or water contaminated with compounds such as PAHs and chlorinated compounds (chlorinated phenols; Barbeau et al. 1997). Anaerobic slurry reactors have been used to treat soil- or water-containing compounds such as highly chlorinated solvents and nitrated munitions like 2,4,6-trinitrotoluene (TNT,  Fig. 11.1; Funk et al. 1995b) or aerobically recalcitrant herbicides like dinoseb (Kaake et al. 1992).

Water often is treated in simple vessels known as batch reactors, which hold from a few hundred to many thousands of liters. Nutrients, microorganism, or both may be added to promote degradation of particular contaminants. Another variation on reactors designed for treatment of water is the fluidized bed. Fluidized beds usually contain biomass immobilized on or within carriers (e.g., polysaccharide-based beads, plastic saddles, sand particles, etc.). These carrier matrixes are circulated

Bangor Naval Weapons Station
January 1995



40 Cubic Yard Demonstration

 Fig. 11.1
Anaerobic slurry reactor for treating TNT-contaminated soil
(photograph courtesy of Tom Yergovich, J. R. Simplot Company)

continuously within the vessel to ensure that environmental conditions are maintained uniformly throughout the system. Fluidized beds are particularly useful and frequently used for water treatment (Nyer 1992). They are run either aerobically or anaerobically (Voice et al. 1995; Sayles and Suidan 1993). Even very toxic and recalcitrant compounds such as nitrobenzene or aniline have been treated successfully in microbiologically acclimated fluidized beds.

It should be pointed out that one of the by-products of bioremediation is the microorganisms themselves. In many cases, water released into the environment must contain a low total organic carbon (TOC) content. Recently, it has been shown that TOC associated with bacteria can be reduced by bacteriophages which lyse the cells and allow other bacteria to mineralize the cell carbon (Rosenberg et al. 2010).

Biomass also can be cultivated on a supporting, but stationary, matrix. The matrix is packed into a vessel such as a column. Such an arrangement is known as a packed-bed reactor. Contaminated water passes through the packed matrix where biomass (usually bacteria) eliminates the contaminants by degradation, absorption, or both (King 1992). Packed beds work well for water, but also have been successful for the removal of contaminants from the vapor phase. For example, some chlorinated solvents in their vapor phase can be sparged through a packed-bed reactor. Microorganisms on or within the packed matrix material take in and degrade the gaseous molecules as they pass through the bed (Marsman et al. 1994). A particularly useful variation of the packed-bed reactor is the *biotrickling filter*, which also can be employed for treatment of vapor-phase pollutants (Unterman et al. 1996; Gabriel and Weiss 2003). Within a biotrickling filter, the gaseous phase containing contaminants flows through the packed bed in one direction, and an aqueous nutrient solution flows in the opposite direction.

The *up-flow sludge-blanket reactor* is a water treatment approach that uses unique *bio-granules* containing anaerobic bacteria that have been acclimated for the degradation of waste components within a particular waste stream (Wu et al. 1993). The granules contain a mixed microbiota consortium that acts as a community with biodegradative capacities far beyond those of individual members.

As mentioned previously, bioreactors can be used in unique combinations as treatment trains that vary conditions to obtain specific results not possible with single reactors. The most common approach is the simple system of alternating anaerobic and aerobic conditions for treating mixtures of oxidized and reduced contaminants. Such systems also may work for some highly chlorinated compounds that are first reductively dehalogenated (in an anaerobic reactor), producing products that are then mineralized by aerobic microorganisms in a second reactor (Evans et al. 1996). Aerobic and anaerobic series reactors have been proposed for contaminants like PCBs and solvents like the tetrachloroethylene (perchloroethylene, also known as PCE). Many other variations of serial reactors are possible. For example, an abiotic reactor (UV light or Fenton reagent) can precede a biotic reactor (Büyüksönmez et al. 1998a, b).

Biofiltration

Another established method for treatment of gas-phase contaminants is biofiltration. An *ex situ* process (Deshusses 1997; Leson and Winer 1991), as shown in Fig. 11.2, biofiltration requires the passing of contaminated air through a bed of soil, peat, or compost. These materials first must be pre-acclimated to the contaminants being treated to select a microbial consortium that can detoxify or completely mineralize the targeted pollutants (Yudelson and Tinari 1995). Biofiltration works particularly well for volatile components of petroleum. It is commonly used in Europe for odor control (Ottengraf 1986), and use of the method in the United States is increasing due to its simplicity and effectiveness (Deviny et al. 2010). The following lists some Internet sites that discuss biofiltration technology:

www.kumc.edu
www.rcf.usc.edu
www.scf.usc.edu
www.cce.uc.edu
www.inel.gov
<http://194.178.172.97/class/ixg02.htm>
<http://194.178.172.97/aboutgrn.htm>
<http://online.awma.org>
www.proact-usa.com

Biofiltration works to degrade a diversity of airborne contaminants, including industrial chemicals like styrene (Arnold et al. 1997), pentane and isobutane mixtures (Barton et al. 1997), toluene (Matteau and Ramsay 1997), chlorinated benzenes (Oh and Bartha 1994), dimethylsulfide (Pol et al. 1994), ethylene (Elsgaard 1998), and other volatile organic compounds (VOCs; Leson and Winer 1991). Maintenance of good degradative activity of biofilter microbial communities sometimes requires the addition of nutrients to the biofiltration matrix, since materials like peat or wood chips are generally nutrient poor. Adjustments and careful control of environmental variables such as temperature, pH, and availability of moisture (humidity) also are often required (Arnold et al. 1997; Matteau and Ramsay 1997). Removal rates for contaminants by biofilters can be impressive. For example, removal of vapors of chlorinated compounds (chlorinated benzenes, in one instance) was measured at 300 g of solvent vapor · h⁻¹ · m³ of filter volume (Oh and Bartha 1994).

Air Sparging

Biodegradation of many contaminants requires the availability of an electron acceptor to be reduced at the expense of oxidation of the contaminant(s). In groundwater, electron acceptor concentrations often are limited, especially for oxidative processes. Though numerous compounds can serve as electron acceptors for respiratory processes (oxygen, nitrate, Fe³⁺, Mn³⁺, and others), the most effective electron acceptor for the bioremediation of many contaminants is oxygen. Oxygen is present in pristine ground water at only 8–10 mg/l, and in most ground

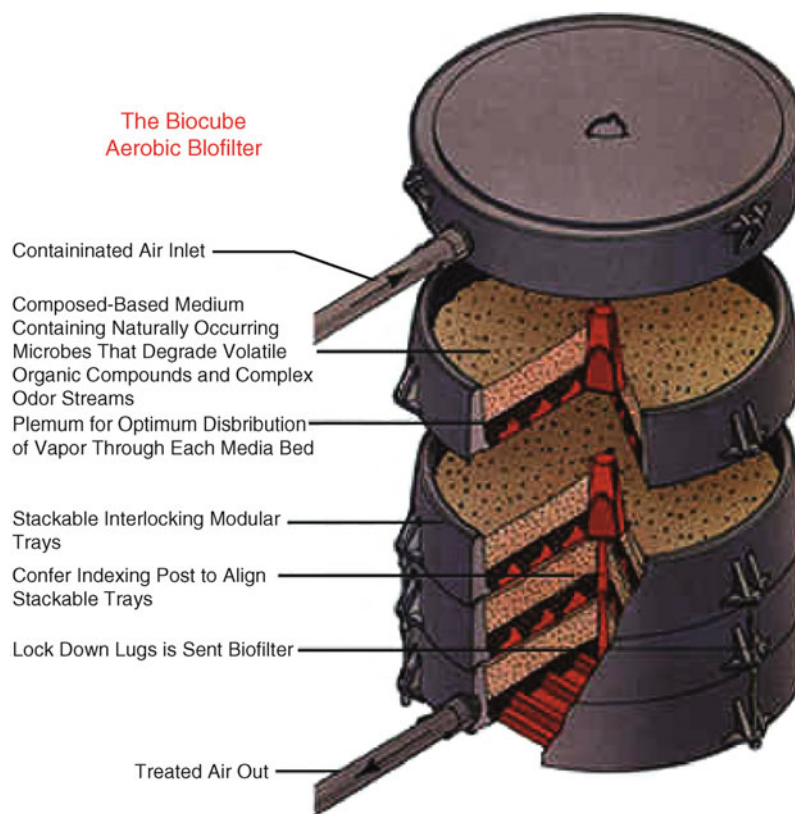
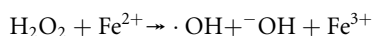

Fig. 11.2

Example of design of a biofiltration unit for removal of vapor-phase contaminants; illustration from ProAct Services Corporation (<http://www.proact-usa.com/biocube.html>)

water, the levels are even lower. Oxygen can be introduced into ground water by a process called *air sparging*, an in situ technology (Raymond et al. 1975). Air or even pure oxygen is injected into an aquifer through specially designed sparging wells or infiltration galleries (Bowlen and Kosson 1995). Oxygen is such a good electron acceptor (effective energy production for cellular metabolism) that air sparging runs the risk of overstimulating microbial growth. A resulting problem can be *biofouling*, where injection wells become plugged with biomass, which obstructs well screens and seals off the aquifer formation from further aeration. Additional problems include the plugging of subsurface geologic formations by iron-containing precipitates formed by the oxidation of ferrous ions (Fe^{2+}) to ferric ions (Fe^{3+}) and the subsequent formation of ferric oxyhydroxides or other highly insoluble iron minerals. Hydrogen peroxide can be used as a convenient source of oxygen, since it decomposes in the presence of iron or biomass to produce oxygen (Frankenberger et al. 1989). Another potential advantage of hydrogen peroxide is that some iron minerals may catalyze its decomposition to hydroxyl radicals by the well-known Fenton process (Haber and Weiss 1934):



Hydroxyl radicals produced by Fenton reactions are exceptionally reactive and can attack contaminants in groundwater

(Tyre et al. 1991), degrading them to products that may be more susceptible to breakdown by microbial populations than the original contaminants. In fact, hydroxyl radicals generated by modified Fenton reactions react with most environmental contaminants at near diffusion-controlled rates ($>10^9 \text{ M}^{-1} \cdot \text{s}^{-1}$). The degradation of xenobiotic chemicals by hydroxyl radicals then proceeds via either hydroxylation or hydrogen atom abstraction:

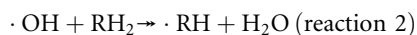

More work is required to determine how effective this “abiotic/biotic” approach to in situ bioremediation might be (Büyüksönmez et al. 1998a, b).

Even when oxygen is supplied by sparging, it can be used so rapidly that its supply can still be rate limiting for bioremediation processes. Thus, the bioremediation industry has developed oxygen-releasing compounds (ORCs) composed of materials such as magnesium peroxide that allow controlled, long-term release of oxygen when introduced into boreholes as a slurry (Kao and Borden 1994). Most successes with air sparging, as with many other bioremediation systems, have been reported in petroleum-contaminated aquifers. The reintroduction of indigenous microorganisms isolated from a contaminated site after

culturing is one approach to in situ hydrocarbon bioremediation. It is effective especially when microorganism growth is supplemented by addition of oxygen and nitrogen (Korda et al. 1997). At the Moffett Field (Sunnyvale, Calif.) groundwater test site, in situ removal of *c*-DCE (*cis*-dichloroethylene) and TCE (trichloroethylene) coincided with biostimulation through phenol and oxygen injection and utilization, with *c*-DCE removed more rapidly than TCE. Greater TCE and *c*-DCE removal was observed when the phenol concentration was increased. Over 90 % removal of *c*-DCE and TCE was observed in a 2-m biostimulated zone (Hopkins et al. 1993). Thus, introduction of oxygen into contaminated aquifers can be of use even for recalcitrant compounds such as VOCs.

Bioventing

Bioventing is an in situ technique and a cousin of air sparging (Kidd 1996). The objectives of air sparging and bioventing are similar: to provide oxygen to the microbial populations in the subsurface. Bioventing systems use pumps, blowers, and piping systems similar to those used for *soil vapor extraction* (SVE). Where the primary goal of SVE is simply to remove contaminants from the subsurface for physical destruction (e.g., combustion) or adsorption (e.g., to activated carbon), the purpose of bioventing is to promote biological degradation of the vapors as they move through the soil (Kramer and Cullen 1997). Injection or extraction wells or specially designed trenches are connected to vacuum pumps or blowers, which either pull or push air through the unsaturated soil horizons (the vadose zone). The movement of air (oxygen) stimulates the microorganisms naturally present that are capable of degrading the targeted contaminants, using them as energy and carbon sources. Oxygen is used as the terminal electron acceptor for oxidation of the pollutants. Enough oxygen must be supplied to the subsurface to promote in situ contaminant degradation. However, the use of too much flow may force undegraded contaminant into the atmosphere. Flows must be carefully regulated to avoid this loss. Thus, bioventing is most effective when applied to sites containing contaminants that are moderately volatile. Examples of such contaminants include diesel or jet fuels and residues of aged petroleum (Bowlen and Kosson 1995). Bioventing does not work for all sites, even if the site contains an appropriate contaminant. As a general guide, the vadose zone must be permeable enough to allow air to be exchanged at least every 24 h (Hinchee and Ong 1992). For some impermeable soils, such as those containing lots of clay or silt, methods have been developed to make soils more porous for better airflow. For example, this has been accomplished by fracturing soils with pressurized hydraulic fluids or by the use of pressurized air injection (Kaplan 1990). After fractures are formed, bioventing becomes possible. Bioventing has been employed frequently with great success worldwide in the past decade (Bowlen and Kosson 1995; Dupont 1993; Hinchee et al. 1991; Bossert and Compeau 1995). A typical bioventing system is shown in

► Fig. 11.3.

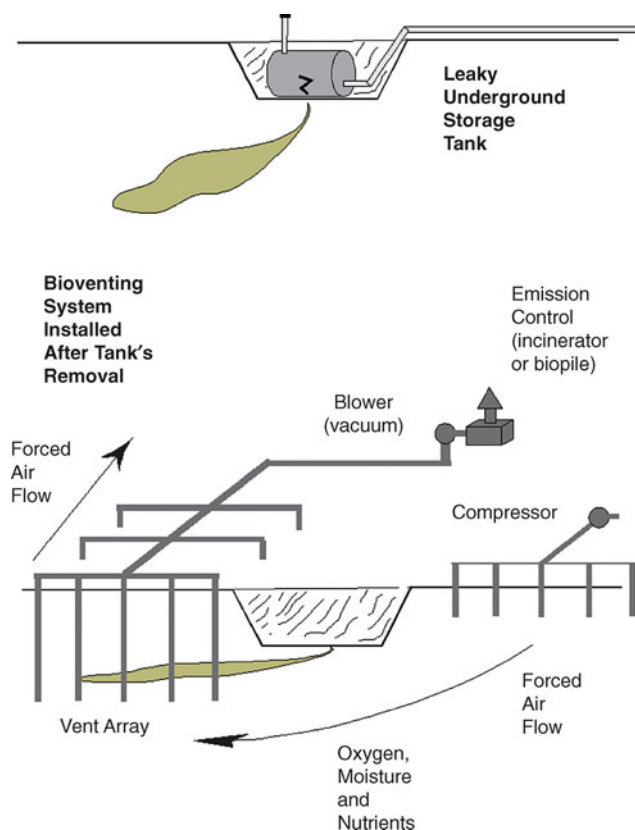

► Fig. 11.3
Typical bioventing operation

During bioventing operations, it is important to ensure that the soil does not become too dry to support microbial growth. Thus, neutron probes sometimes are used for soil moisture monitoring. Soil moisture must be maintained within a range of 6–12 % for biological processes to proceed effectively. An impermeable liner, usually made of plastic, is commonly placed over the surface of a contaminated area. This prevents infiltration of air that might bypass the desired path of air to the vent wells. Extra phosphorus or nitrogen compounds or both may be needed if the soils being treated are poor in these essential nutrients. Nitrogen, in the form of ammonia, can be provided in the gas phase. It is desirable, if possible, to maintain a carbon/nitrogen/phosphorus ratio of about 100:10:1. It is not always possible to ensure that all of the contaminant vapors at a particular site are degraded as they pass through a soil column. Also, most engineered systems are subject to occasional failures in operation or design. Thus, a catalytic incinerator to destroy extracted vapor that was not degraded by microbes in the vadose zone is often installed as a safety device. As mentioned above, not all sites are amenable to bioventing. The Battelle Corporation (Battelle Memorial Institute, Columbus, Ohio) has developed an evaluation protocol that is useful for determining whether a site is suited for remediation by bioventing (Hinchee and Ong 1992). The evaluation involves four steps, performed sequentially:

A soil-gas survey is conducted to determine if the subsurface is oxygen limited. Soil gas is analyzed for concentrations of oxygen and carbon dioxide.

1. A soil-gas permeability test is conducted. This determines if air can be injected at sufficient rates to aerate the vadose zone. The actual test involves injection and withdrawal of air, measuring changes in subsurface pressures at specific distances from the injection point.
2. If a soil is found to be oxygen limited but permeable, it is next subjected to an in situ respiration test. This test measures biological contaminant degradation rates as compared to respiration rates in similar but uncontaminated control soils. For this test, soils are aerated while monitoring the oxygen and carbon dioxide concentrations in the soil-gas phase. Oxygen utilization rates are calculated and used to estimate contaminant degradation rate. These rates can be used later to estimate the time that will be required to treat a site by bioventing.
3. If a site remains a candidate for bioventing after the initial three tests, a pilot-scale bioventing demonstration may be conducted at the site. However, it may be possible to move directly to a full-scale process. This is determined on a site-by-site basis.

Among its advantages, bioventing (1) uses readily available equipment, easy to install; (2) creates minimal disturbance to site operations; (3) can be used in inaccessible areas (e.g., under buildings); (4) requires relatively short treatment times, usually 6 months to 2 years under optimal conditions; (5) is competitively priced (\$45–140 per ton of contaminated soil); (6) is easily combinable with other technologies (e.g., air sparging, groundwater extraction); and (7) may not require costly offgas treatment. Its disadvantages are the following: (1) high constituent concentrations initially may be toxic to microorganisms; (2) certain site conditions (low soil permeability, high clay content, and others) preclude its use; (3) very low cleanup standards cannot always be achieved; (4) permits are generally required for nutrient injection wells (if used); and (5) only unsaturated (vadose) zone soils can be treated.

Landfarming

Landfarming is an ex situ process where contaminated soil is excavated, supplemented with nutrients, and spread in layers on a prepared site to promote biodegradation. The nutrients added usually are nitrogen or phosphorus sources or both, which support the microbial catabolism of the added contaminant carbon. The soils are kept moist by irrigation and aerated by periodic tilling (Bowlen and Kosson 1995). Depending on the contaminants present, soils may or may not be spread directly on the ground at a landfarm site. If there is a danger that the contaminants will leach through the vadose zone to groundwater or vaporize to dangerous levels in the atmosphere, then additional precautions must be considered. For example, soils may be spread on pre-installed plastic liners or clay barriers.

Aqueous leachate collection systems may be constructed to prevent the movement of contaminants off-site or to groundwater. Vapor containment structures may be required, especially if the landfarm is located near populated areas. Petroleum, which is readily biodegraded by soil microbial communities, has been commonly treated by landfarming (Bossert and Compeau 1995). However, highly toxic and/or biologically recalcitrant compounds generally cannot be successfully landfarmed. The presence of heavy metals, such as lead found in some older petroleum products, usually is a negative indication for landfarming. Using this method to treat petroleum-contaminated soil has some advantages: (1) design and implementation are relatively simple; (2) treatment times (usually 6 months to 2 years under optimal conditions) are short; (3) cost (\$30–60 per ton of contaminated soil) is competitive; and (4) treatment is effective for organic constituents with slow biodegradation rates. The disadvantages of landfarming of petroleum-contaminated soil are the following: (1) concentration reductions >95 % and constituent concentrations >0.1 ppm are very difficult to achieve; (2) high constituent concentrations (>50,000 ppm total petroleum hydrocarbons) may reduce or preclude effectiveness; (3) presence of significant heavy metal concentrations (>2,500 ppm) may inhibit microbial growth; (4) volatile constituents tend to evaporate rather than biodegrade during treatment; (5) treatment requires a large land area; (6) dust and vapor generation during aeration may pose air quality concerns; and (7) bottom liners may be required if leaching from the landfarm is a concern. (The data are from US EPA <http://www.epa.gov/swerust1/cat/landfarm.htm>.)

The presence of plants sometimes can enhance the degradation of contaminants during landfarming operations. For example, the degradation of aromatic compounds (PAHs) can be greater in the presence of vegetation than without it. Enhanced microbial activity in the plant root zone seems to contribute to the increased removal of PAHs. Though PAHs can be detected in the tissues of plants grown on landfarms, overall uptake is generally thought to be insignificant. Planting of vegetation not only increases contaminant degradation rates but also helps control erosion and can be an esthetic addition to a treatment site. Use of plants therefore can be an inexpensive means of speeding landfarm-based remediation of sites contaminated with petroleum (Schwab and Banks, 1994).

Biopiles

Biopiles are variants of landfarms that permit treatment conditions to be more directly controlled. Also known as *soil-heaping* operations, biopiles use less land area and produce fewer air emissions than landfarms. Volatile compounds lost from biopiles are readily captured and treated, a major advantage of this technology (Bossert and Compeau 1995). To produce a biopile, soil is excavated and then mounded and covered by a plastic sheet within a lined treatment cell. An internal system of perforated pipes is placed within the pile and used to draw air in by means of vacuum pumps. Air also may be blown into

a biopile through the internal pumping system. Alternatively, oxygen can be supplied from oxygen-releasing compounds (ORCs, see Air Sparging) and mixed into the piles as they are formed. As for all biological processes, careful control of moisture content and nutrient status (particularly the nitrogen to phosphorus to carbon ratio) is required. Water and nutrients are added as needed. Special microbial cultures can be added (Walter 1997), though this is rarely done in practice. Most contaminants treated in biopiles are degradable by natural microbial populations already present in the soil, if conditions are made favorable for their growth. Leachates and gaseous emissions are collected for separate treatment. Biopiles can be used for most biodegradable contaminants, but most of the limitations of landfarming still apply. To date, most biopile operations have treated petroleum-contaminated soils (Bossert and Compeau 1995).

Biomounds are lower cost variations of biopiles and also have been used to treat petroleum-contaminated soil. Biomounding is the addition of bulking materials like animal manure and wood chips to help retain moisture, provide good aeration, and supply readily available sources of nitrogen, phosphorus, and trace nutrients for growing microbial populations capable of hydrocarbon degradation. This simple process usually can reach stringent soil cleanup standards in the range of 10 ppm of residual petroleum in the soil (known as *total petroleum hydrocarbons*, or TPH). As with biopiles, indigenous bacteria present in petroleum-contaminated soil proliferate under biomounding conditions. Addition of exogenous microbes is not normally required. Biomounds thus are relatively inexpensive to manage and fairly fast at the breakdown of petroleum residues in soil. Though the construction seems much like that of a standard compost heap, biomounds are designed not to require continual turning of the soil as is done during traditional composting. Simple passive aeration systems are used that usually include a grid, sometimes with multiple layers of horizontal piping constructed of flexible, perforated drain tile, along with vertical piping (risers) of PVC. Biomounds generate heat from their biological activity, and it is usually desirable to retain much of this heat, along with moisture, by covering mounds with plastic sheeting.

Composting

Composting is a familiar and effective process for preparing high quality soil additives from organic materials. It also is of value in treatment of hazardous wastes. In composting of contaminated soil, excavated soil is first mixed with bulking agents like straw, horse manure, or other agricultural residues. The mixture then is formed into piles that are aerated by periodic turning with specially designed machines. Microbial activity in composts can be very vigorous, generating considerable heat. Composts thus often are termed *thermophilic*, since they may operate at temperatures of 50–60 °C. Composting has been examined as a treatment for a variety of contaminants. Examples include petroleum sludges (McMillin et al. 1993), chlorophenols (Valo and Salkinoja-Salonen 1986; Mueller et al. 1991), and residues of

explosives (Williams, et al. 1992). Some questions remain as to the overall efficacy and effectiveness of composting for treating certain types of contaminants. For example, during composting, some compounds such as the munition compound 2,4,6-trinitrotoluene, or TNT, are polymerized and/or incorporated into compost humus fractions. Thus, there is little or no conversion of these contaminants to carbon dioxide or products that might themselves be degradable to carbon dioxide (Williams et al. 1992). The long-term stability and potential for release of toxic compounds from such uncharacterized materials in soil are not known. Some work has implied that mutagenic metabolites of explosives are formed and incompletely degraded during the composting process (Jarvis et al. 1998). In another study, [¹⁴C]-TNT was subjected to composting. Much of the ¹⁴C became incorporated into the “humic” fraction of the compost. When the composted TNT was fed to rats, about 2.3 % of the total ¹⁴C dose appeared in the rats’ urine during the first 3 days after feeding, and excretion of ¹⁴C in the urine continued for more than 6 months (Palmer et al. 1997). Thus, it is clear that composted TNT is not irreversibly immobilized in the humic fraction of the compost. TNT, or one or more of its biotransformation products in compost, is still bioavailable. Clearly, composting is not the treatment of choice for some wastes, especially when little mineralization of the target pollutant occurs. Thus, composting is still an experimental approach for most hazardous wastes and should be evaluated individually for each new pollutant prior to extensive use. The fates and mechanisms of removal of chemicals like pesticides and other exotic compounds in composting processes are largely a mystery (Fogarty and Tuovinen 1991; Michel et al. 1995; Kästner et al. 1995). Continued research on composting for treatment of hazardous wastes is slowly building on our knowledge base and overcoming some of the prior limitations. Recent work, for example, indicates that TNT can be degraded more effectively if the compost is allowed to undergo a fairly long anaerobic phase before traditional aerobic composting (Breitung et al. 1996). Recently, it was shown that fluoranthene could be successfully bioremediated using composting technology (Lashermes et al. 2010).

Microbiological agents also can pose a hazard in composted materials (Marsh et al. 1979; Millner et al. 1977). The presence of pathogenic bacteria and fungi is of particular concern. Their presence depends largely on composting methods, and additional research is needed on the risks to human health and the environment of exposure to potentially hazardous chemical residues, heavy metals (Keller and Brunner 1983), and microorganisms in composted waste (Deportes et al. 1995). The danger from pathogenic microorganisms centers on fungi such as *Aspergillus fumigatus*. Spores of this causal agent of the lung disease aspergillosis are abundant in the air near some composting sites (Marsh et al. 1979; Millner et al. 1977). Thus, site location is of considerable importance during design of composting operations. Overall, though the simplicity and affordability of composting for hazardous waste treatment are attractive, the efficacy and safety of this method for treatment of many wastes are still an open question.

Intrinsic Bioremediation

Intrinsic remediation is result of the combined effects of all natural processes in contaminated environments that reduce the mobility, mass, and risks of pollutants (Hinchee et al. 1995). The mechanisms of intrinsic remediation include the following: (1) biodegradation or biotransformation of contaminants by indigenous microbial populations, (2) sorption to or trapping within matrixes or on mineral phases that make toxic compounds non-bioavailable, and (3) loss of toxicity by dilution or volatilization (Frankenberger and Karlson 1991). Intrinsic remediation of petroleum hydrocarbons has been well documented (Rifai et al. 1995; Wiedermeier et al. 1995). Intrinsic remediation also has been confirmed for chlorinated compounds (chlorinated solvents) in anoxic environments that promote reductive dehalogenation of chlorinated hydrocarbons (Hinchee et al. 1995; Rifai et al. 1995). Evidence indicates that natural evolution by genetic exchange within the environment can lead to novel microbial populations that degrade xenobiotic contaminants (van der Meer et al. 1998).

Risk-based assessments become the basis for determining cleanup end points when intrinsic processes are considered as methods for site remediation. In such cases, the distribution of contaminants must be determined. These analyses include obtaining data that allow an understanding of the extent of contaminant plume migration in relation to sensitive receptors, such as groundwater. These analyses require extensive sampling at most sites of the vadose zone and aquifers. Analyses also must confirm that pollutant remediation is proceeding at a rate sufficient to reduce risks to human health and the environment in an acceptable period. Measurements that can provide the required information include the following: (1) the contaminant mass and its environmental distribution; (2) the abundance of contaminant-degrading or contaminant-transforming microorganisms, as indicated by actual microbial counts or other evidence of their presence; (3) the temperature and pH of the environment to show that they are appropriate for microbial activity; (4) types of electron donors and acceptors present, and changes in their concentrations (e.g., concentrations of nitrate, nitrite, redox-active metal species like iron, methane, ammonia, carbon dioxide, and sulfate); (5) redox potential; and (6) other factors, including abiotic ones, that must be determined on a site-by-site basis and will depend on what contaminant(s) is present. Ideally, the efficacy of intrinsic remediation processes should be predictable at individual sites using computer models, though modelers are a long way from this ideal. It is obvious, however, that intrinsic remediation has its place in the repertoire of environmental restoration tools, but it requires specific, extensive, and long-term activities at a site. It is never a “do-nothing” option.

Phytoremediation

Phytoremediation involves the use of plants to remove contaminants from soil or water. Though proposed primarily as a means

to remove toxic metals from environmental systems, phytoremediation also has been suggested for bioremediation of some organic pollutants (Bolton and Gorby 1995). Through a process called *phytoextraction*, contaminants are taken into a plant and concentrated within the plant tissues (Kelly and Guerin 1995; Cunningham et al. 1995). When the plants are harvested, the sequestered contaminants are thereby removed from the environment. Some investigators have suggested that bacteria associated with root zones (the rhizosphere) of plants may degrade organic contaminants, also indicating a potential to use phytoremediation for removal of organic pollutants from soil or water. However, additional research is needed to confirm which plants degrade or sequester which contaminants. Plants, particularly those with deep roots, may remove volatile contaminants from soil as they transpire water. The contaminants are carried through the vascular tissue of the plant and released to the atmosphere with transpired water vapor. Recently, Rugh et al. (1998) developed a genetically engineered yellow poplar tree that expresses the bacterial mercury reductase gene (*merA*) in the plant's tissue. Mercury reductase converts nonvolatile Hg^{2+} to volatile Hg^0 , which the tree pumps into the atmosphere. Thus, this deep-rooted tree has the potential for use in mercury phytoremediation, if it proves to be effective at getting to the mercury bound in soil, and the release of mercury vapor to the air is judged to be safe. Besides their direct effects on contaminants, plants also serve a useful function in the stabilization of polluted sites. Plant cover reduces soil erosion and the infiltration of water into soil. The latter process may decrease or eliminate the leaching of mobile contaminants into groundwater (Bolton and Gorby 1995; Cunningham et al. 1995). Plants appear to have special potential for the challenging task of removal of radionuclides from soil or water (Cornish et al. 1995).

In practice, plants are grown on a contaminated site and allowed to concentrate contaminants like metals or radioactive compounds into their tissues. After an appropriate time, they are harvested and burned to reduce the volume of collected material, typically by about 95 %. This volume reduction, and the accompanying concentration of hazardous material in the ash, greatly decreases the ultimate cost of waste disposal. Though usually not economically feasible, useful metals might be extracted from the ash as industrial products. For example, after harvest, a plant may contain as much as 1 % or more by weight of a particular metal. The ash of this plant would contain about 20 % by weight of that metal, a higher metal content than is found in many ores. Unfortunately, the amounts of metals that might be obtained in this way are small compared to those obtained from traditional mining processes.

Phytoremediation is not a panacea. It can be a very slow process. Thus, it is not an acceptable option for sites that represent an immediate public health or environmental threat and require immediate cleanup. Plant roots also may not grow deep enough to access contaminants at many sites. Most plants used for phytoremediation send their roots to depths of 0.3–10 m. Some trees used in phytoremediation may send their roots somewhat deeper. However, it is improbable that plant roots,

■ Table 11.1

Plants proposed for use in phytoremediation

Plant	Comment
Alfalfa	Symbiotic with hydrocarbon-degrading bacteria
Arabidopsis	Genetically engineered to carry a bacterial gene that transforms mercury into a gaseous state
Bladder campion	Accumulates zinc and copper
Indian mustard greens (<i>Brassica juncea</i>)	Accumulates selenium, sulfur, lead, chromium, cadmium, nickel, zinc, and copper
Boxwood (Buxaceae)	Accumulates nickel
Compositae	Symbiotic with bacteria, accumulates cesium and strontium
Euphorbiaceae	Succulent plants that accumulate nickel
Tomato	Accumulates lead, zinc, and copper
Poplar	Used in the absorption of the pesticide atrazine and solvents like carbon tetrachloride
Alpine pennycress (<i>Thlaspi caerulescens</i>)	Accumulates zinc and cadmium

even under the best of circumstances, can contact all the soil within a contaminated zone. Thus, several cropping seasons may be required to phytoremediate any particular site. Furthermore, plants require a narrow range of growth temperatures. They also grow well only in the presence of favorable soil qualities (texture, water-holding capacity, pH, presence of oxygen, etc.). They must obtain enough water to support growth and metabolism, so irrigation may be required at dry sites. Plants also may be inefficient at taking up some pollutants, allowing contaminants to reach groundwater. All of these potentially negative factors must be considered before phytoremediation is chosen as a remedial option for any particular site.

Some plants proposed for use in phytoremediation (<http://www.ecological-engineering.com/phytoem.html>) are shown in ► Table 11.1.

White-Rot Fungi

Fungi have been used for bioremediation (Bennett and Faison 1997). White-rot fungi, as shown in ► Fig. 11.4, are wood-degrading microorganisms that produce special oxidases, enzymes that help degrade the plant polymer lignin as well as a great variety of chemicals, including many environmental pollutants (Paszczynski and Crawford 1995). Thus, these fungi have been examined extensively as potential bioremediation agents. The peroxidases (known as ligninases or manganese peroxidases) of the basidiomycete *Phanerochaete chrysosporium* are the most thoroughly investigated of the xenobiotic-



■ Fig. 11.4

The white-rot fungus *Fomitopsis pinicola* (common name, red-banded conk). Photographed by Dr. Andrzej Paszczynski in the University of Idaho Experimental Forest, Moscow Mountain, Moscow, Idaho

compound-degrading fungal enzymes. These and other oxidative fungal enzymes like laccase appear to initiate degradation of many xenobiotic molecules, such as the chlorinated compounds (including PCBs; Novotny et al. 1997).

For application in the field, white-rot fungi are grown on a cellulose substrate such as wood chips. Some commercial companies have developed specially formulated proprietary lignocellulosic (lignocellulose) materials for growing fungal mycelia. These colonized materials provide both a carrier for the organism and a carbon and energy source (cellulose) to support pollutant cometabolism. The carriers are mixed directly into a polluted soil, which then is tilled, watered, and managed to encourage the growth and lignin-degrading activity of the introduced fungus. As the fungus consumes its lignocellulosic carrier, it simultaneously degrades the contaminants through the fortuitous activities of its oxidases. This technology is still experimental. The fungi used thus far can be inhibited by the contaminant concentrations found in some soils. With some contaminants, degradation may be incomplete. Thus, more development work is required before white-rot fungi see significant use in the treatment of contaminated soil.

The focus of many recent studies has been the fungus *Phanerochaete chrysosporium*. For example, this fungus was shown to enhance the indigenous rate of mineralization of aromatic compounds (such as PAHs) in one soil system (Brodkorb and Legge 1992). Among the *P. chrysosporium* genes implicated in pollutant degradation are two lignin peroxidase genes. The mRNA transcripts of these genes were detected directly in a soil being treated by fungal inoculation (Lamar et al. 1995). Thus, the use of white-rot fungi appears most promising for specific classes of contaminants including the PAHs (Brodkorb and Legge 1992) and some chlorinated phenols (Paszczynski and Crawford 1995). Additional research, however,

is required before use of white-rot fungi becomes common practice. There remains the possibility of identifying many more strains of white-rot fungi that might be suitable for use as bioremediation agents. Hundreds of species of white-rot fungi have never been examined in this regard.

Bioremediation of Oil Spills at Sea

In considering the bioremediation of petroleum, it is useful to distinguish between open systems, for example, oceans, and closed systems, for examples, reactors. In closed systems, it is relatively simple to satisfy the necessary nitrogen and phosphorus requirements for efficient microbial growth and hydrocarbon degradation by the addition of water-soluble inorganic compounds. An early example of a controlled experiment demonstrating enhanced petroleum bioremediation in a closed seawater system was the cleaning of a cargo compartment of an oil tanker by addition of urea and phosphate (Gutnick and Rosenberg 1977). However, there is at present no practical microbial solution to the reoccurring problem of petroleum pollution in the sea, because of the difficulty of providing the necessary nitrogen and phosphorus supplements. Addition of common fertilizers containing nitrogen and phosphorus is not effective in open systems because of rapid dilution.

To overcome the N limitation for petroleum degradation in open systems, Atlas and Bartha (1973) studied the effectiveness of several oleophilic nitrogen compounds with low C:N ratios. It was reported that paraffinized urea was particularly efficient. The authors stressed that, because of the high affinity of such oleophilic nutrients for the oil phase, these materials enhance growth of petroleum-degrading microorganisms selectively, thus minimizing their possible contribution toward algal bloom formation. Subsequently, an oleophilic fertilizer (Inipol EAP 22 = oleic acid, urea, lauryl phosphate) was used in the bioremediation of polluted shorelines following the Exxon Valdez spill (Atlas 1991; Lindstrom et al. 1991). Initial reports of success (Crawford 1990; Pritchard et al. 1992) have been challenged (Button et al. 1992). There are at least three problems with Inipol EAP 22. First, it contains large amounts of oleic acid, which serve as an alternative carbon source, thereby increasing the C:N ratio in the environment. Second, it contains toxic compounds. Third, as soon as the fertilizer comes into contact with water, the emulsion breaks, releasing urea into the water phase where it is not available for the microorganism. Another approach has been the use of a water-insoluble polymer, based on a urea-formaldehyde formulation, that adheres to oil (Rosenberg et al. 1996). This latter fertilizer was used successfully to bioremediate a heavily oil-contaminated sandy beach. Also slow-release fertilizers and chitosan have been used to treat oil-contaminated sediments (Xu et al. 2004, 2005). None of the above technologies has been shown to be effective in treating oil at sea. Using a simulated open system, it was recently demonstrated that commercial guano was an effective source of nitrogen and phosphorus for the growth of marine bacteria on crude oil (Knezevich et al. 2006).

Limitations of Bioremediation

Bioremediation has the limitations inherent in any biological system. Thus, bioremediation is not always an appropriate approach for restoration of a contaminated site. The first requirement for use of bioremediation is that environmental conditions must support biological activity. For example, the extreme ranges of pH, temperature, or radioactivity seen at some sites generally are not tolerated by degradative organisms. Microorganisms require nitrogen, phosphorus, sulfur, and a number of trace elements. These must be present and in forms that are available to microbial cells. The presence of overly toxic concentrations of heavy metals like mercury, lead, and zinc or of other antimicrobial substances may inhibit or even prevent bioremediation processes. In other instances, the concentrations of contaminants may be so low that they do not provide sufficient energy for microbial growth. If alternative energy sources are unavailable and cannot be added, then even cometabolism may not be an option. Contaminants may not be accessible to microorganisms. This might occur, for example, if they are tightly adsorbed to clays or soil organic matter or have found their way into pores that are smaller than bacteria. Even such non-bioavailable contaminants still may be subject to very stringent remediation standards set and enforced by regulatory agencies. Contaminants more often than not occur in mixtures. Sometimes, these are so complex that the most likely bioremediation processes may remove only some of the waste components. Those that remain still may be regulated. In other instances, the site to be treated (e.g., a large, deep aquifer) may not be accessible to manipulations needed to promote bioremediation. Despite the amazing versatility of microorganisms for the degradation of xenobiotic molecules, some man-made compounds simply are not biodegradable. In summary, bioremediation is just one tool in the environmental engineer's repertoire. It will be used frequently, but not for all sites or situations.

References

- Admassu W, Korus RA (1996) Engineering of bioremediation processes: needs and limitations. In: Crawford RL, Crawford DL (eds) *Bioremediation: principles and applications*. Cambridge University Press, Cambridge, UK, pp 13–34
- Arnold M, Reittu A, von Wright A, Martikainen PJ, Suihko ML (1997) Bacterial degradation of styrene in waste gases using a peat filter. *Appl Microbiol Biotechnol* 48:738–744
- Atlas RM (1991) Microbial hydrocarbon degradation-bioremediation of oil spills. *J Chem Technol Biotechnol* 52:149–156
- Atlas RM, Bartha R (1973) Stimulated biodegradation of oil slicks using oleophilic fertilizers. *Environ Sci Technol* 7:538–541
- Barbeau C, Deschenes L, Karamanev D, Comeau Y, Samson R (1997) Bioremediation of pentachlorophenol-contaminated soil by bioaugmentation using contaminated soil. *Appl Microbiol Biotechnol* 48:745–752
- Barton JW, Klasson KT, Koran LT Jr, Davison BH (1997) Microbial removal of alkanes from dilute gaseous waste streams: kinetics and mass transfer considerations. *Biotechnol Prog* 13:814–821
- Bennett JW, Faison BD (1997) Use of fungi in biodegradation. In: Hurst CJ, Knudsen GR, McInerney MJ, Stetzenback LD, Walter MV (eds) *Manual of environmental microbiology*. ASM Press, Washington, DC, pp 758–765

- Bolton H Jr, Gorby YA (1995) An overview of the bioremediation of inorganic contaminants. In: Hincsee RE, Means JL, Burris DR (eds) *Bioremediation of inorganics*. Battelle, Columbus, OH
- Bossert ID, Compeau GC (1995) Cleanup of petroleum hydrocarbon contamination in soil. In: Young LY, Cerniglia CE (eds) *Microbial transformation and degradation of toxic organic chemicals*. Wiley-Liss, New York, NY, pp 77–125
- Bowlen GF, Kosson DS (1995) In situ processes for bioremediation of BTEX and petroleum fuel products. In: Young LY, Cerniglia CE (eds) *Microbial transformation and degradation of toxic organic chemicals*. Wiley-Liss, New York, NY, pp 514–542
- Breitung J, Bruns-Nagel D, Steinbach K, Kaminski L, Gemsa D, von Low E (1996) Bioremediation of 2,4,6-trinitrotoluene-contaminated soils by two different aerated compost systems. *Appl Microbiol Biotechnol* 44:795–800
- Brodkorb TS, Legge RL (1992) Enhanced biodegradation of phenanthrene in oil-tar-contaminated soils supplied with *Phanerochaete chrysosporium*. *Appl Environ Microbiol* 58:3117–3121
- Brunsbach FR, Reineke W (1994) Degradation of chlorobenzenes in soil slurry by a specialized organism. *Appl Microbiol Biotechnol* 42:415–420
- Button DK, Robertson BR, McIntosh D, Juttner F (1992) Interactions between marine bacteria and dissolved-phase and beached hydrocarbons after the Exxon Valdez oil spill. *Appl Environ Microbiol* 58:243–251
- Büyüksönmez F, Hess TF, Crawford RL, Paszczynski A, Watts RA (1998a) Effects of modified fenton reactions on *Xanthobacter flavus* FB71. *Appl Environ Microbiol* 64(10):3759–3764
- Büyüksönmez F, Hess TF, Crawford RL, Paszczynski A, Watts RA (1998b) Simultaneous abiotic-biotic mineralization of perchlorethylene (PCE). In: Proceedings, first international conference on the remediation of chlorinated and recalcitrant compounds, May 1998 Monterey, CA Battelle Press, Columbus, OH, pp 277–282
- Cornish JE, Goldberg WC, Levine RS, Benemann JR (1995) Phytoremediation of soils contaminated with toxic elements and radionuclides. In: Means JL, Burris DR, Hincsee RE (eds) *Bioremediation of inorganics*. Battelle, Columbus, OH, pp 55–63
- Crawford M (1990) Bacteria effective in Alaska cleanup. *Science* 247:1537
- Cunningham SD, Berti WR, Huang JW (1995) Remediation of contaminated soils and sludges by green plants. In: Hincsee RE, Means JL, Burris DR (eds) *Bioremediation of inorganics*. Battelle, Columbus, OH, pp 33–54
- Deportes I, Benoit-Guyod JL, Zmirou D (1995) Hazard to man and the environment posed by the use of urban waste compost: a review. *Sci Total Environ* 172:197–222
- Deshusses MA (1997) Biological waste air treatment in biofilters. *Curr Opin Biotechnol* 8:335–339
- Devigny JS, Deshusses MA, Webster TS (2010) *Biofiltration for air pollution control*. CRC Press, London
- Dupont RR (1993) Fundamentals of bioventing applied to fuel-contaminated sites. *Environ Progr* 12:45–53
- Elsgaard L (1998) Ethylene removal by a biofilter with immobilized bacteria. *Appl Environ Microbiol* 64:4168–4173
- Evans BS, Dudley CA, Klasson KT (1996) Sequential anaerobic-aerobic biodegradation of PCBs in soil slurry microcosms. *Appl Biochem Biotechnol* 57/58:885–894
- Focht DD (1997) Aerobic biotransformation of polychlorinated biphenyls. In: Hurst CJ, Knudsen GR, McInerney MJ, Stetzenback LD, Walter MV (eds) *Manual of environmental microbiology*. ASM Press, Washington, DC, pp 811–814
- Fogarty AM, Tuovinen OH (1991) Microbiological degradation of pesticides in yard waste composting. *Microbiol Rev* 55:225–233
- Frankenberger WT Jr, Karlson U (1991) Bioremediation of seleniferous soils. In: Hincsee RE, Olfenbuttel RF (eds) *On-site bioreclamation: processes for xenobiotic and hydrocarbon treatment*. Butterworth-Heinemann, Stoneham, MA, pp 239–254
- Frankenberger WT Jr, Emerson KD, Turner DW (1989) In situ bioremediation of an underground diesel fuel spill: a case history. *Environ Manage* 13:325–332
- Funk SB, Crawford DL, Roberts DJ, Crawford RL (1995a) Two-stage bioremediation of TNT-contaminated soils. In: Schepart BS (ed) *Bioremediation of pollutants in soil and water*, ASTM STP 125. American Society for Testing and Materials, Philadelphia, PA, pp 177–189
- Funk SB, Crawford DL, Crawford RL, Mead G, Davis-Hoover W (1995b) Full-scale anaerobic bioremediation of trinitrotoluene (TNT)-contaminated soil: a U.S. EPA SITE program demonstration. *Appl Biochem Biotechnol* 51/52:625–633
- Gabriel F, Weiss J (2003) Retrofitting existing chemical scrubbers to biotrickling filters for H₂S emission control. *Proc Natl Acad Sci (USA)* 100:6308–6312
- Gutnick DL, Rosenberg E (1977) Oil tankers and pollution: a microbiological approach. *Ann Rev Microbiol* 31:379–396
- Haber F, Weiss J (1934) The catalytic decomposition of hydrogen peroxide by iron salts. *Proc R Soc London: Ser A* 147:332–351
- Hincsee RE, Ong SK (1992) A rapid in situ respiration test for measuring aerobic biodegradation rates of hydrocarbons in soils. *J Air Waste Manage Assoc* 42:1305–1312
- Hincsee RE, Downey DC, Dupont RR, Aggarwal P, Miller P (1991a) Enhancing biodegradation of petroleum hydrocarbons through bioventing. *J Haz Mat* 27:315–325
- Hincsee RE, Wilson JT, Downey DC (eds) (1995) *Intrinsic bioremediation*. Battelle Press, Columbus, OH
- Hopkins GD, Semprini L, McCarty PL (1993) Microcosm and in situ field studies of enhanced biotransformation of TCE by phenol-utilizing microorganisms. *Appl Environ Microbiol* 59:2277–2285
- Jarvis SA, McFarland VA, Honeycutt ME (1998) Assessment of the effectiveness of composting for the reduction of toxicity and mutagenicity of explosive-contaminated soil. *Ecotoxicol Environ Safety* 39:131–135
- Kaake RH, Roberts DJ, Stevens TO, Crawford RL, Crawford DL (1992) Bioremediation of soils contaminated with 2-sec-butyl-4,6-dinitrophenol (dinoseb). *Appl Environ Microbiol* 58:1683–1689
- Kao C-M, Borden RC (1994) Enhanced aerobic bioremediation of a gasoline-contaminated aquifer by oxygen-releasing barriers. In: Hincsee RE, Alleman BC, Hopple RE, Miller RN (eds) *Hydrocarbon bioremediation*. Lewis Publishers, Boca Raton, FL, pp 262–266
- Kaplan DL (1990) Biotransformation pathways of hazardous energetic organo-nitro compounds. In: Kamely D, Chakrabarty A, Omenn GS (eds) *Biotechnology and biodegradation*. Portfolio Publishing, Houston, TX, pp 152–182
- Kästner M, Lotter S, Heerenklage J, Breuer-Jammali M, Stegmann R, Mahro B (1995) Fate of ¹⁴C-labeled anthracene and hexadecane in compost manured soil. *Appl Microbiol Biotechnol*, 43:1128–1135
- Keller L, Brunner PH (1983) Waste-related cadmium cycle in Switzerland. *Ecotoxicol Environ Safety* 7:141–150
- Kelly RT, Guerin TF (1995) Feasibility of using hyperaccumulating plants to bioremediate metal-contaminated soil. In: Hincsee RE, Means JL, Burris DR (eds) *Bioremediation of inorganics*. Battelle, Columbus, OH, pp 25–32
- Kidd DF (1996) Fracturing. In: Nyer E (ed) *In situ treatment technology*. Lewis Publishers, Boca Raton, FL, pp 245–269
- King RB (1992) *Practical environmental bioremediation*. CRC Press, Boca Raton, FL
- Kner M, Lotter S, Heerenklage J, Breuer-Jammali M, Stegmann R, Mahro B (1995) Fate of 14 C-labeled anthracene and hexadecane in compost-manured soil. *Appl Microbiol Biotechnol* 43:1128–1135
- Knezevic V, Koren O, Ron EZ, Rosenberg E (2006) Petroleum bioremediation in seawater using guano as the fertilizer. *Bioremed J* 10:83–91
- Korda A, Santas P, Tenente A, Santas R (1997) Petroleum hydrocarbon remediation: sampling and analytical techniques, in situ treatments, and commercial microorganisms currently used. *Appl Microbiol Biotechnol* 48:677–686
- Koren O, Knezevic V, Ron EZ, Rosenberg E (2003) Petroleum bioremediation using water insoluble uric acid as the nitrogen source. *Appl Environ Microbiol* 69:6337–6339
- Korus RA (1997) Scale-up of processes for bioremediation. In: Hurst CJ, Knudsen GR, McInerney MJ, Stetzenback LD, Walter MV (eds) *Manual of environmental microbiology*. ASM Press, Washington, DC, pp 856–864
- Kramer JH, Cullen SJ (1997) Bioventilation and modeling of airflow in soil. In: Hurst CJ, Knudsen GR, McInerney MJ, Stetzenback LD, Walter MV (eds) *Manual of environmental microbiology*. ASM Press, Washington, DC, pp 746–752
- LaGrega MD, Bunkingham PL, Evans JC (1994) *Hazardous waste management*. McGraw Hill, New York, NY

- Lamar RT, Schoenike B, Vanden Wymelenberg A, Stewart P, Dietrich DM, Cullen D (1995) Quantitation of fungal mRNAs in complex substrates by reverse transcription PCR and its application to *Phanerochaete chrysosporium*-colonized soil. *Appl Environ Microbiol* 61:2122–2126
- Lashermes G, Houot S, Barriuso E (2010) Sorption and mineralization of organic pollutants during different stages of composting. *Chemosphere* 79:455–462
- Leson G, Winer AM (1991) Biofiltration: an innovative air pollution control technology for VOC emissions. *J Air Waste Manage Assoc* 41:1045–1054
- Lindstrom JE, Prince RC, Clark JC, Grossman MJ, Yeager TR, Braddock JF, Brown EJ (1991) Microbial populations and hydrocarbon biodegradation potentials in fertilized shoreline sediments affected by the T/V Exxon Valdez oil spill. *Appl Environ Microbiol* 57:2514–2522
- Marsh PB, Millner PD, Kla JM (1979) A guide to the recent literature on aspergillosis as caused by *Aspergillus fumigatus*, a fungus frequently found in self-heating organic matter. *Mycopathologica* 69:67–81
- Marsman EH, Appleman JMM, Urlings LG, Bult BA (1994) Biopur, an innovative bioreactor for the treatment of groundwater and soil vapor contaminated with xenobiotics. In: Hinchee RE, Anderson DB, Metting FB Jr (eds) *Applied biotechnology for site remediation*. Lewis Publishers, Boca Raton, FL, pp 391–399
- Matteau Y, Ramsay B (1997) Active compost biofiltration of toluene. *Biodegradation* 8:135–140
- McMillin SJ, Kerr JM, Gray NR (1993) Microcosm studies of factors that influence bioremediation of crude oil in soil. In: *Proceedings, SPE/EPA exploration and production environmental conference*, San Antonio, TX, March 7–10, 1993. Society of Petroleum Engineers, Dallas, TX, pp 389–401
- Michel FC Jr, Reddy CA, Forney LJ (1995) Microbial degradation and humification of the lawn care pesticide 2,4-dichlorophenoxyacetic acid during the composting of yard trimmings. *Appl Environ Microbiol* 61:2566–2571
- Millner PD, Marsh PB, Snowden RB, Parr JF (1977) Occurrence of *Aspergillus fumigatus* during composting of sewage sludge. *Appl Environ Microbiol* 34:765–772
- Mueller JG, Lanz SE, Baltmann BO, Chapman PJ (1991) Bench-scale evaluation of alternative biological treatment processes for the remediation of pentachlorophenol- and creosote-contaminated materials: slurry-phase bioremediation. *Environ Sci Technol* 25:1055–1061
- Novotny C, Vyas BR, Erbanova P, Kubatova A, Sasek V (1997) Removal of PCBs by various white-rot fungi in liquid cultures. *Folia Microbiol (Praha)* 42:136–140
- Nyer KE (1992) *Groundwater treatment technology*. Van Nostrand Reinhold, New York, NY
- Oh YS, Bartha R (1994) Design and performance of a trickling air biofilter for chlorobenzene and o-dichlorobenzene vapors. *Appl Environ Microbiol* 60:2717–2722
- Ottengraf SPP (1986) Exhaust gas purification. In: Rehm HJ, Reed G (eds) *Biotechnology*, vol 8. VCH, Weinheim, pp 301–322
- Palmer WG, Beaman JR, Walters DM, Creasia DA (1997) Bioavailability of TNT residues in composts of TNT-contaminated soil. *J Toxicol Environ Health* 51:97–108
- Paszczynski A, Crawford RL (1995) Potential for bioremediation of xenobiotic compounds by the white-rot fungus *Phanerochaete chrysosporium*. *Biotechnol Progr* 11:368–379
- Pol A, Op den Camp HJ, Mees SG, Kersten MA, van der Drift C (1994) Isolation of a demethylsulfide-utilizing *Hyphomicrobium* species and its application in biofiltration of polluted air. *Biodegradation* 5:105–112
- Pritchard PH, Mueller JG, Rogers JC, Kremer VF, Glaser JA (1992) Oil spill bioremediation: experiences, lessons and results from the Exxon Valdez oil spill in Alaska. *Biodegradation* 3:315–335
- Raymond RL, Jamison VW, Hudson JO (1975) Beneficial stimulation of bacterial activity in groundwater containing petroleum products, API Publication 4427. American Petroleum Institute, Washington, DC
- Rifai HS, Borden RC, Wilson JT, Ward CW (1995) Intrinsic bioattenuation for subsurface restoration. In: Hinchee RE, Wilson JT, Downey DC (eds) *Intrinsic bioremediation*. Battelle, Columbus, OH, pp 1–29
- Ron EZ, Rosenberg E (2009) Role of fertilizers: biostimulation. In: Timmis KN (ed) *Handbook of hydrocarbon and lipid microbiology*. Springer, Heidelberg
- Rosenberg E, Legmann R, Kushmaro A, Adler E, Abir H, Ron EZ (1996) Oil bioremediation using insoluble nitrogen source. *J Biotechnol* 51:273–278
- Rosenberg E, Bittan-Banin G, Shon A, Hershko G, Levy I, Ron EZ (2010) The phage-driven microbial loop in petroleum bioremediation. *Microb Biotechnol* 3:467–472
- Rugh CL, Senecoff JF, Meagher RB, Merkle SA (1998) Development of transgenic yellow poplar for mercury phytoremediation. *Nat Biotechnol* 16:925–928
- Sayles GD, Suidan MT (1993) Biological treatment of industrial and hazardous wastewater. In: Levin MA, Gealt MA (eds) *Biotreatment of industrial and hazardous wastes*. McGraw Hill, New York, NY, pp 245–268
- Schwab AP, Banks MK (1994) Biologically mediated dissipation of polyaromatic hydrocarbon in the root zone. In: Anderson TA, Coats JR (eds) *Bioremediation through rhizosphere technology*, vol 563, ACS Symposium Series. American Chemical Society, Washington, DC, pp 132–141
- Shuttleworth KL, Cerniglia CE (1997) Practical methods for the isolation of polycyclic aromatic hydrocarbon (PAH)-degrading microorganisms and the determination of PAH mineralization and biodegradation intermediates. In: Hurst CJ, Knudsen GR, McInerney MJ, Stetzenback LD, Walter MV (eds) *Manual of environmental microbiology*. ASM Press, Washington, DC, pp 766–775
- Tyre BW, Watts RJ, Miller GC (1991) Treatment of four biorefractory contaminants in soils using catalyzed hydrogen peroxide. *J Environ Qual* 20:832–838
- Unterman R, Folsom BR, Togna AP (1996) Mechanically mixed packed bed reactor. U.S. patent 5,494,574. U.S. Patent Office, Washington, DC
- Valo R, Salkinoja-Salonen M (1986) Bioreclamation of chlorophenol-contaminated soil by composting. *Appl Microbiol Biotechnol* 25:68–75
- van der Meer JR, Werlen C, Nishino S, Spain JC (1998) Evolution of a pathway for chlorobenzene metabolism lead to natural attenuation in contaminated groundwater. *Appl Environ Microbiol* 64:4185–4193
- Voice TC, Zhao X, Shi J, Hickey RF (1995) Biological activated carbon fluidized-bed system to treat gasoline-contaminated groundwater. In: Hinchee RE, Sayles GD, Skeen RS (eds) *Biological unit processes for hazardous waste treatment*. Battelle, Columbus, OH, pp 29–36
- Wackett LP (1997) Biodegradation of halogenated solvents. In: Hurst CJ, Knudsen GR, McInerney MJ, Stetzenback LD, Walter MV (eds) *Manual of environmental microbiology*. ASM Press, Washington, DC, pp 784–789
- Walter MV (1997) Bioaugmentation. In: Hurst CJ, Knudsen GR, McInerney MJ, Stetzenback LD, Walter MV (eds) *Manual of environmental microbiology*. ASM Press, Washington, DC, pp 753–757
- Wiedermeier TH, Swanson MA, Wilson JT, Campbell DH, Miller RN, Hansen JE (1995) Patterns of intrinsic bioremediation at two U.S. Air Force bases. In: Hinchee RE, Wilson JT, Downey DC (eds) *Intrinsic bioremediation*. Battelle, Columbus, OH, pp 31–51
- Williams RT, Ziegenfuss PS, Sick WE (1992) Composting of explosives and propellant-contaminated soils under thermophilic and mesophilic conditions. *J Ind Microbiol* 9:137–144
- Wu WM, Bhatnagar L, Zeikus JG (1993) Performance of anaerobic granules for degradation of pentachlorophenol. *Appl Environ Microbiol* 59:389–397
- Xu R, Lau NLA, Ng KL, Obbard JP (2004) Application of a slow-release fertilizer for oil bioremediation in beach sediment. *J Environ Qual* 33:1210–1216
- Xu R, Lau AN, Lim YG, Obbard JP (2005) Bioremediation of oil-contaminated sediments on an inter-tidal shoreline using a slow-release fertilizer and chitosan. *Mar Pollut Bull* 51:1062–1070
- Yudelson JM, Tinari PD (1995) Economics of biofiltration for remediation projects. In: Hinchee RE, Sayles GD, Skeen RS (eds) *Biological unit processes for hazardous waste treatment*. Battelle, Columbus, OH, pp 205–209

Additional References for Specific Topics Biofiltration

- Alonso C, Smith PJ, Suidan MT, Sorial GA, Biswas P, Smith FL, Brenner RC (1995) Gas treatment in trickle-bed biofilters: a modeling approach and experimental study. In: *Proceedings of the water environmental*

- federation 68th annual conference and exposition, Miami Beach, FL, October 21–25
- Alonso C, Suidan MT, Kim BR, Kim BJ (1996). Dynamical mathematical model for the biodegradation of VOC's in a biofilter: biomass accumulation study. In: Proceedings of the water environmental federation 69th annual conference and exposition, Dallas, TX, October 5–9
- Alonso C, Suidan MT, Sorial GA, Smith FL, Biswas P, Smith PJ, Brenner RC (1997a) Gas treatment in trickle-bed biofilters: biomass, how much is enough? *Biotechnol Bioeng* 54:583–594
- Alonso C, Zhu X, Suidan MT, Kim BR, Kim BJ (1997b) Effect of nitrate on VOC removal in a gas phase biofilter. In: Proceedings of the water environmental federation 70th annual conference and exposition, Chicago, IL
- Alonso C, Zhu X, Suidan MT, Kim BR, Kim BJ (1997c) Nutrients and electron acceptors effect in a vapor phase bioreactor. In: Proceedings of the in situ and on-site bioremediation, 4th international symposium, New Orleans, LA
- Apel WA, Turick CE (1993) The use of denitrifying bacteria for the removal of nitrogen oxides from combustion gases. *Fuel* 72(12):1715–1718
- Apel WA, Kant WD, Colwell FS, Singleton B, Lee BD, Andrews GE, Espinosa AM, Johnson EG (1994a) Chapter 9. Removal of gasoline vapors from air streams by biofiltration. In: Tedder DW, Pohland FG (eds) *Emerging technologies in hazardous waste management, IV*. American Chemical Society, Washington DC, pp 142–159
- Apel WA, Walton MR, Dugan PR (1994b) An evaluation of autotrophic microbes for the removal of carbon dioxide from combustion gas streams. *Fuel Process Technol* 40:139–149
- Apel WA, Barnes JM, Barrett KB (1995a) Biofiltration of nitrogen oxides from fuel combustion gas streams. In: Proceedings of the 88th annual meeting of the air and waste management association, Paper 95-TP9C.04, San Antonio, TX, June 1995
- Apel WA, Lee BD, Walton MR, Cook LL, Dinerstein KB (1995b) Removal of α -pinene from off-gases by biofiltration. In: Proceedings of the 88th annual meeting of the air and waste management association. Paper No. 95-TP9C.07, San Antonio, TX, June 1995
- Barnes JM, Apel WA, Barrett KB (1995) Removal of nitrogen oxides from gas streams using biofiltration. *J Haz Mat* 41:315–326
- Bohn H (1992) Consider biofiltration for decontaminating gases. *Chem Eng Progr* 88(4):34–40
- Deviny JS, Deshusses MA, Webster TS (1998) *Biofiltration for air pollution control*. CRC Lewis Publishers, Boca Raton, FL, 320 pp
- Lee BD, Apel WA, Barnes JM, Walton MR, Barrett KB, Cook LL (1995) Biofiltration using different modes of biodegradation. In: Proceedings of the 1995 conference on biofiltration, University of Southern California, Los Angeles, CA, October 1995, pp 309–316
- Lee BD, Apel WA, Cook LL, Nichols KM (1996) Effect of bed medium moisture on alpha-pinene removal by biofilters. In: Proceedings of the 1996 conference on biofiltration. University of Southern California, Los Angeles, CA. October 1996
- Lee BD, Apel WA, Walton MR, Cook LL (1996) Treatment of methanol contaminated air streams using biofiltration. In: Proceedings of the 89th annual meeting of the air and waste management association. Paper 96-RP87C.03. Nashville, TN. June 1996
- Lee BD, Apel WA, Walton MR (1997) Utilization of toxic gases and vapors as alternate electron acceptors in biofilters. In: Proceedings of the 90th annual meeting of the air and waste management association. Paper 97-WA71A.05, Toronto, Canada, June 1997
- Smith FL, Sorial GA, Suidan MT, Breen AW, Biswas P, Brenner RC (1996) Development of two biomass control strategies for extended, stable operation of highly efficient biofilters with high toluene loadings. *Environ Sci Technol* 30:1744–1751
- Sorial GA, Smith FL, Suidan MT, Biswas P (1995) Evaluation of trickle bed biofilter media for toluene removal. *J Air Waste Manage Assoc* 45:801–810
- Zhu X, Rihn MJ, Suidan MT, Kim BJ, Kim BR (1996a) The effect of nitrate on VOC removal in trickle bed biofilters. *Water Sci Technol* 34(3–4):573–581
- Zhu XM, Rihn J, Suidan MT, Kim BJ, Kim BR, Paik BC (1996b) Role of nitrate in trickle bed biofilters: nutrient or electron acceptor. In: Proceedings of the water environmental federation 69th annual conference and exposition, Dallas, TX, October 5–9

Bioventing

- Hinchee RE (1993) Bioventing of petroleum hydrocarbons. In: *Handbook of bioremediation*. Lewis Publication, Boca Raton, FL, pp 39–59
- Hinchee RE, Ong SK, Hoepfel R (1991) A treatability test for bioventing. In: Proceedings of the 84th annual meeting and exhibition, air and waste management association, Vancouver, BC, pp 91–19.4
- Hinchee RE, Ong SK, Miller RN, Downey DC (1992) Report to AFCEE. Brooks AFB, TX
- Hoepfel RE, Hinchee RE, Arthur MF (1991) Bioventing soils contaminated with petroleum hydrocarbons. *J Ind Microbiol* 8:141–146
- Leeson A, Hinchee RE (1996a) Principles and practices of bioventing, vol 2: bioventing principles, vol 2. Battelle Memorial Institute for U.S. Air Force and U.S. EPA, Columbus, OH
- Leeson A, Hinchee RE (1996b) Principles and practices of bioventing, vol 2: bioventing design, vol 2. Battelle Memorial Institute for U.S. Air Force and U.S. EPA, Columbus, OH
- Norris RD, Hinchee RE, Brown RA, McCarty PL, Semprini L, Wilson JT, Campbell DH, Reinhard M, Bower EJ, Borden RC, Vogel TM, Thomas JM, Ward CH (1994) *Handbook of bioremediation*. CRC Press, Boca Raton, FL
- U.S. Environmental Protection Agency (EPA) (1991a) Guide for conducting treatability studies under CERCLA: aerobic biodegradation remedy screening. Office of Emergency and Remedial Response, Washington, DC, EPA/540/2-91/013A
- U.S. Environmental Protection Agency (EPA) (1991b) Soil vapor extraction technology: reference handbook. Office of Research and Development, Cincinnati, OH, EPA/540/2-91/003
- U.S. Environmental Protection Agency (EPA) (1991c) Guide for conducting treatability studies under CERCLA: soil vapor extraction. Office of Emergency and Remedial Response, Washington, DC, EPA/540/2-91/019A
- U.S. Environmental Protection Agency (EPA) (1993) Decision-support software for soil vapor extraction technology application: hyperVentilate. Office of Research and Development, Cincinnati, OH, EPA/600/R-93/028
- USAEC (1997) Bioventing of POL contaminated soils. In: Innovative technology demonstration, evaluation and transfer activities, FY 96 annual report, report no. SFIM-AEC-ET-CR-97013, pp 75–76
- Wisconsin Department of Natural Resources (DNR) (1993) Guidance for design, installation and operation of soil venting systems. Emergency and Remedial Response Section, Madison, WI, PUBL-SW185-93

Phytoremediation

The phytoremediation bibliography <http://www.rtdf.org/phytodoc.htm>: >1,000 citations on phytoremediation and related topics

12 Biodeterioration

Ji-Dong Gu¹ · Ralph Mitchell²

¹School of Biological Sciences, Faculty of Science, The University of Hong Kong, Hong Kong SAR

²Laboratory of Applied Microbiology, School of Engineering and Applied Sciences, Harvard University, Cambridge, MA, USA

Introduction	309	Detection and Preventive Strategies	327
Corrosion of Metals	312	Conclusions	329
Microorganisms Involved in Corrosion	312		
Aerobic Microorganisms	312		
Strictly Anaerobic Microorganisms	314		
Mechanisms of Microbial Corrosion	314		
Aerobic Conditions	314		
Anaerobic Conditions	315		
Alternation Between Aerobic and Anaerobic Conditions	316		
Other Processes Contributing to Corrosion	316		
Inhibition of Corrosion by Microorganisms	317		
Nonferrous Metals	317		
Biodeterioration of Polymeric Materials	318		
Microorganisms and Degradation of Synthetic Polymers	318		
Degradable Polymers	319		
Biopolymers	320		
Chemically Modified Biopolymers	320		
Chemically Synthesized Polymers	321		
Recalcitrant Polymers	321		
Electronic Insulation Polymers	321		
Fiber-Reinforced Polymeric Composite Materials	322		
Corrosion Protective Coatings	322		
Nondegradable Polymers	322		
Corrosion of Concrete and Stone	323		
Microorganisms Responsible for Deterioration	324		
Microbial Exopolymers	325		
Corrosion of Reinforcing Materials	326		
Biodeterioration of Cultural Heritage Materials	326		

Introduction

Bacteria were the first life forms to appear on Earth, and they have a long history of association with mineral surfaces. Surfaces of clay minerals played an important role in the initial evolutionary processes of bacteria and the diversification of their physiology (Kluyver and van Niel 1956; Mayr 1998; Wächtershäuser 1988; Woese 1987, 1990, 1998; Woese and Olsen 1986). Bacteria also adapt themselves to a mode of living on physical surfaces and at interfaces (Angles et al. 1993; Bitton 1980; Brune et al. 2000; Caldwell et al. 1997; Fenchel and Finlay 1995; Fletcher 1980; Glagolev 1984; Hugenholtz et al. 1998; Margulis 1981; Marshall 1992; Moat and Foster 1988; Pace 1997; Wolfaardt et al. 1994; Zavarzin et al. 1994; Zinder 1993). In addition, they are capable of degrading a wide range of pollutants (Gibson 1984; Gu and Berry 1991, 1992; Gu et al. 1992a; Young and Cerniglia 1995). It is well recognized that degradation of organic chemicals and nutrient cycling are more rapid on surfaces. Unfortunately, microbial association with surfaces also has a potential negative economic impact, when it accelerates degradation and deterioration of a wide range of materials, including inorganic minerals (Gu et al. 2000b; Mitchell and Gu 2000), concrete, and stone (Gebers and Hirsch 1978; Gu et al. 2000b; Moosavi et al. 1986; Padival et al. 1995; Piervittori et al. 1994; Prieto et al. 1995); metals (Ford and Mitchell 1990b; Gu et al. 2000a; Miller 1970); and natural and synthetic polymers (Gu et al. 2000d; Guezennec et al. 1998; Swift et al. 1979). In all cases, the essential ingredient is the close association between the microflora and the material surface.

Under natural conditions, all surfaces are covered with microorganisms except for extremely clean rooms. Biofilm formation is the process by which a complex community of microorganisms becomes established on a surface. Biofilms can exist in many different forms and have many different compositions (Fig. 12.1). They are ubiquitous on surfaces in soil and aquatic environments (Ford 1993) and are also present on materials exposed to humidity, particularly in tropical and subtropical climates. For example, microbial biofilms are common on surfaces of ancient archaeological limestone in Southern Mexico (Fig. 12.2). This process of biofilm formation is prerequisite to

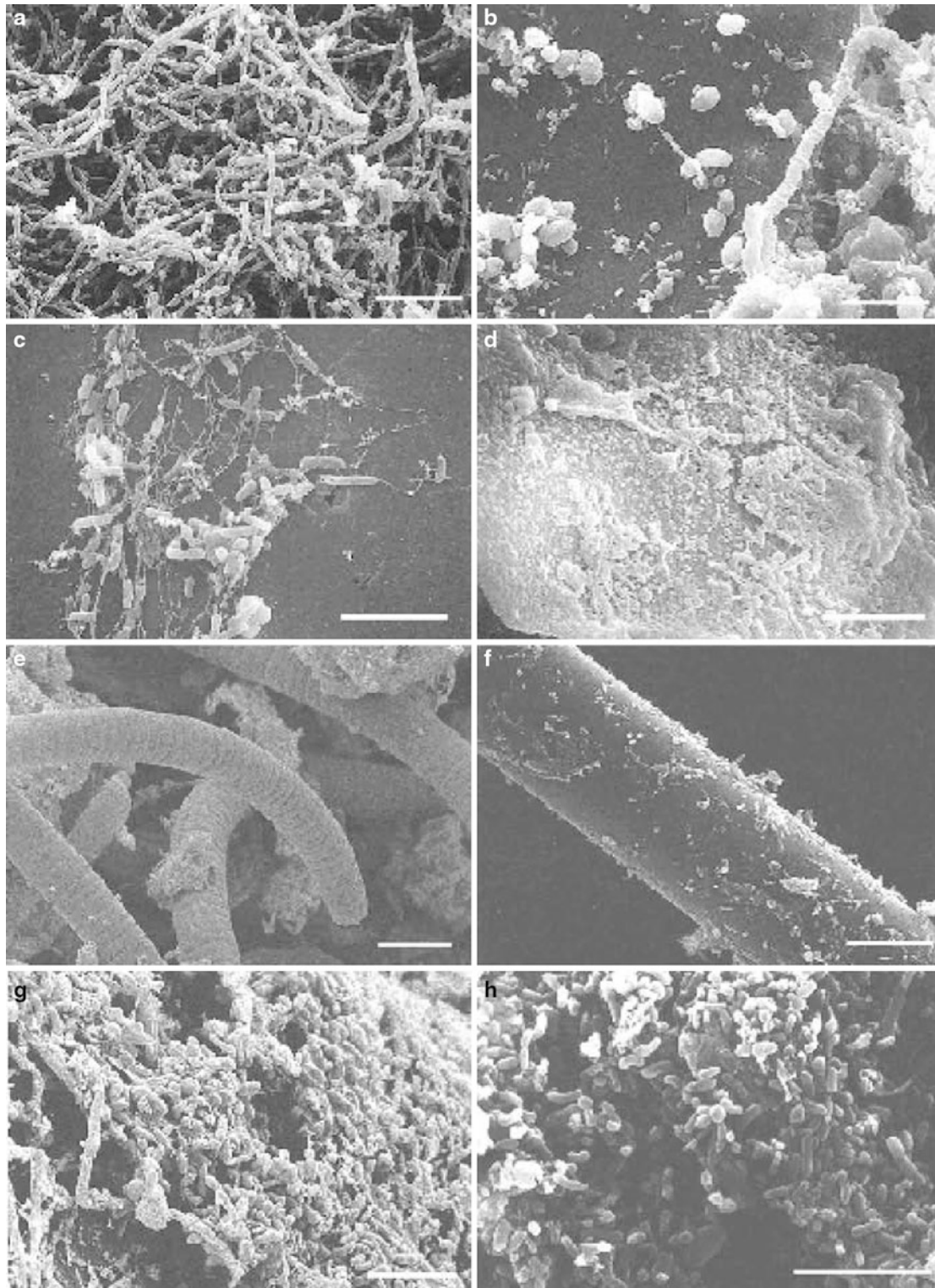

■ Fig. 12.1

Scanning electron micrographs of biofilms on (a) a stainless steel coupon after a 1-month incubation in the Merrimack River, Massachusetts, United States ($bar = 10 \mu\text{m}$), (b) contaminated air-conditioner condenser ($bar = 10 \mu\text{m}$), (c) urinary tract catheter after use ($bar = 5 \mu\text{m}$), (d) dental suture after 3 days in a patient's mouth ($bar = 5 \mu\text{m}$), (e) phototrophic organisms on stone surfaces from a tropical region ($bar = 5 \mu\text{m}$), (f) fiber (from a bioreactor) used for immobilization of pollutant-degrading microorganisms ($bar = 10 \mu\text{m}$), (g) an artificial carrier of fiber after immersion for 20 days in a wastewater treatment plant ($bar = 5 \mu\text{m}$), and (h) surface of a sewer's concrete pipe ($bar = 5 \mu\text{m}$)



■ Fig. 12.2
Photographs showing (a) an ancient Mayan temple made of limestone covered by microbial biofilms, (b) a close-up view near the base, and (c) the contrast between newly replaced and original stone

substantial corrosion and/or deterioration of the underlying materials (Arino et al. 1997; Saiz-Jimenez 1995, 1997; Walch 1992).

Biofilms on surfaces are highly structured (Breznak 1984; Costerton et al. 1978, 1994; Dalton et al. 1994; Davey and O'Toole 2000; Kelly-Wintenberg and Montie 1994; Lappin-Scott et al. 1992; L'Hostis et al. 1997; O'Toole et al. 2000; Wimpenny and Colasanti 1997). Architectural structure and the organization of microorganisms on a particular surface are generally material specific, dependent on surface properties (Fletcher and Loeb 1979; van Loosdrecht et al. 1987, 1990; Wiencek and Fletcher 1995) and ambient conditions, including externally supplied electrical current, cation concentration, solution chemistry, and hydrodynamic conditions (Caldwell

and Lawrence 1986; Korber et al. 1989; Lawrence et al. 1987; Lewandowski et al. 1995; Leyden and Basiulis 1989; Little et al. 1986b; Marshall et al. 1971; Martrhamuthu et al. 1995; Neu 1996; Pendyala et al. 1996; Power and Marshall 1988; Rijnaarts et al. 1993; Schmidt 1997; Sneider et al. 1994; Stoodley et al. 1997). All surfaces may act as substrata for bacterial adhesion and biofilm formation (Busscher et al. 1990; Costerton et al. 1995; Geesey and White 1990; Geesey et al. 1996; Marshall 1980), and microbial attack on materials can take place either directly or indirectly, depending on the specific microorganism and on the biology, chemistry, and physical properties of the materials and their environment (Gu et al. 2000c). Specifically, these factors may include material composition (Bos et al. 1999; Busscher et al. 1990; Wiencek and Fletcher 1995), the nature of the surface (Becker et al. 1994; Caldwell et al. 1997; Callow and Fletcher 1994), and the indigenous microflora. In addition, other factors affecting the physical environment influence the extent of bacterial adhesion, including ionic strength of the solution, type of cation, hydrodynamic force, and surface properties (e.g., hydrophobicity or hydrophilicity; Bos et al. 1999; Fletcher 1996; Marshall 1976). Recently, chemical signaling has been found to play a role in bacterial attachment on surfaces (Davies et al. 1998; McLean et al. 1997; Reynolds and Fink 2001).

Microbial biofilms immobilized on solid materials are exploited in pollutant biodegradation, wastewater treatment, and bioleaching (Bryers 1990, 1994; Osswald et al. 1995; Sharp et al. 1998). In contrast, biofilms are undesirable in food processing, energy production, and on submerged mechanical equipment surfaces. Biofouling is generally defined as the undesirable accumulation of microorganisms, their products, deposits such as minerals and organic matter, and macroorganisms on a substratum surface (Novikova and Zalogoyev 1985; Nefedov et al. 1988; Solomin 1985; Sunesson et al. 1995; Viktorov 1994; Viktorov and Novikova 1985; Viktorov and Ilyin 1992; Viktorov et al. 1993; Zaloguyev 1985). The thin film on fouled surfaces usually consists of microorganisms embedded in an organic matrix of biopolymers, which are produced by the microorganisms under natural conditions. In addition, microbial precipitates, minerals, and corrosion products may be present (Beveridge et al. 1997; Konhauser et al. 1994; Liken 1981; Lovley 1991; Pierson and Parenteau 2000; Zehnder and Stumm 1988). Industrial fouling is a complex phenomenon involving interactions between chemical, biological, and physical processes. Materials immersed in aqueous environments or under high humidity conditions are susceptible to biofouling (Characklis 1990; Gu et al. 1998c; Jones-Meehan et al. 1994a, b; Knyazev et al. 1986; Little et al. 1990; Thorp et al. 1994). These include medical implants (Dobbins et al. 1989; Gu et al. 2001a; McLean et al. 1995; Mittelman 1996), water pipes (Rogers et al. 1994), artificial coatings (Edwards et al. 1994; Gu et al. 1998b; Jones-Meehan et al. 1994b; Stern and Howard 2000; Thorp et al. 1997), rubber (Berekaa et al. 2000), ultrapure systems (Flemming et al. 1994; Mittelman 1995), porous media (Bouwer 1992; Cunningham et al. 1990, 1991; Mills and Powelson 1996; Rittman 1993; Vandevivere 1995; Vandevivere and Kirchman 1993; Williams

and Fletcher 1996), water and wastewater treatment equipment (Bryers and Characklis 1990; Gillis and Gillis 1996; Rethke 1994; Tall et al. 1995), oilfield water systems (Lynch and Edyvean 1988), equipment on the space station (Gazenko et al. 1990; Meshkov 1994; Novikova et al. 1986; Pierson and Mishra 1992; Stranger-Joannesen et al. 1993; Zaloguyev 1985), and magnetic diskettes (McCain and Mirocha 1995).

In general, biodeterioration is described as the undesirable degradation of materials by microorganisms. The term “biodeterioration” also implicitly includes biocorrosion and biodegradation. All three terms, “corrosion,” “degradation,” and “deterioration,” will be used in this chapter. In the following sections, microbial deterioration of metals, polymeric materials, concrete, and stone will be discussed.

Corrosion of Metals

Biodeterioration of materials includes the corrosion of metals, a process commonly called “microbiological induced/influenced corrosion” (MIC) by corrosion engineers. This process affects a wide range of industrial materials, including those in oil fields, offshore drilling platforms, pipelines, pulp and paper factories, armaments, nuclear and fossil fuel power plants, chemical manufacturing facilities, and food processing plants (Corbett et al. 1987; Evans 1948; Hill et al. 1987; Kobrin 1993; Pope et al. 1989; Sequeira and Tiller 1988; Widdel 1992; Zachary et al. 1980). Significant economic loss has resulted from undesirable processes caused by the growth of microorganisms and subsequent accumulation of fouling organisms (Jensen 1992; Ross 1994). Corrosion has severe economic consequences. It was estimated that 70 % of the corrosion in gas transmission lines is due to problems caused by microorganisms. The American oil refining industry loses \$1.4 billion a year from microbial corrosion (Knudsen 1981). The terminology of microbiological corrosion and the term “microfouling” have frequently been used interchangeably. The term “MIC” is not clearly defined and is commonly misused.

Biocorrosion of metals was first reported by von Wolzogen Kuhr and van der Vlugt (1934) more than 60 years ago. A wide variety of microorganisms are capable of degradation of metal alloys: the causative microorganisms include both aerobic and anaerobic bacteria. In the early studies, most attention was given to the strictly anaerobic sulfate-reducing bacteria (SRB; see the reviews by Dexter 1993; Dowling and Guezenc 1997; Dowling et al. 1992; Eashwar et al. 1995; Evans 1948; Ford and Mitchell 1990a, b; Gu et al. 2000a; Hamilton 1985; Lee et al. 1995). In addition to SRBs, thermophilic bacteria, iron-oxidizing bacteria, and exopolymer- and acid-producing bacteria were found to participate actively in corrosion processes by mechanisms in which metal ions are either transformed by or complexed with functional groups of the exopolymers, resulting in release of metallic species into solution (Chen et al. 1995, 1996; Clayton et al. 1994; Ford and Mitchell 1990b; Little et al. 1986b; Paradies 1995; Schmidt 1986; Siedlarek et al. 1994).

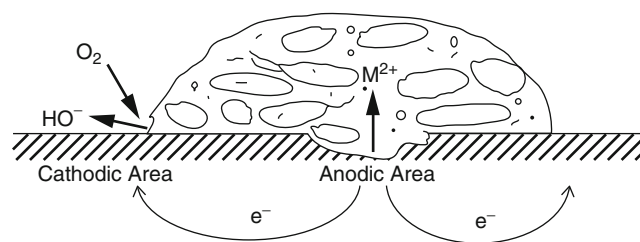

Fig. 12.3 Schematic of an aeration zone created by a biofilm, with resultant corrosion. Metallic cations (M^{2+}) are released from the anodic area

Corrosion of metals is a result of both electrochemical and biological processes occurring on or near material surfaces, initiated and accelerated by microbial activity (the formation of complex microbial biofilms and metabolism of microorganisms on surfaces; Breslin et al. 1997; Ford and Mitchell 1990b; Gu et al. 1998a, c; Walch 1992). In the process, surface-attached microorganisms alter the chemical and biological environments on the substratum. The microbial communities, in turn, form differential aeration zones under aerobic conditions because dissolved oxygen is consumed beneath microbial colonies (Uhlir and Revie 1985).

The difference in oxygen concentrations on two localized and adjacent areas generates an electrochemical potential and electron flow (Fig. 12.3). The area more exposed to oxygen serves as a cathode, whereas the area underneath the microbial biofilm serves as an anode, resulting in dissolution of metallic matrices, crevice corrosion, and pitting (Ford and Mitchell 1990b; Gu et al. 2000a; Vaidya et al. 1997; Videla 1996; Walch et al. 1989; Wang 1996). Subsequently, the decrease in oxygen levels provides an opportunity for anaerobic microorganisms to become established within biofilms. In particular, activity of anaerobic sulfate-reducing bacteria has been shown to directly cause corrosion of underlying metals by a process of cathodic depolarization. In addition, methanogenic microorganisms may participate in the corrosion process (Daniels et al. 1987; Kim et al. 1996). Overall, the interactions between chemistry and biology create unique niches for the propagation of corrosion. Methods used to study biocorrosion are available in the literature (Hungate 1969; Murray et al. 1993; Peng and Park 1994; Tatnall 1986; Wagner and Ray 1994). The participating microorganisms and their corrosive processes under different environmental conditions are discussed below.

Microorganisms Involved in Corrosion

Aerobic Microorganisms

Several groups of aerobic microorganisms play an important role in corrosion, including the sulfur bacteria, the iron- and manganese-depositing and exopolymer-producing bacteria, and fungi and algae. Figure 12.4 shows bacteria and corrosion products on the surface of a stainless steel cold water pipe.

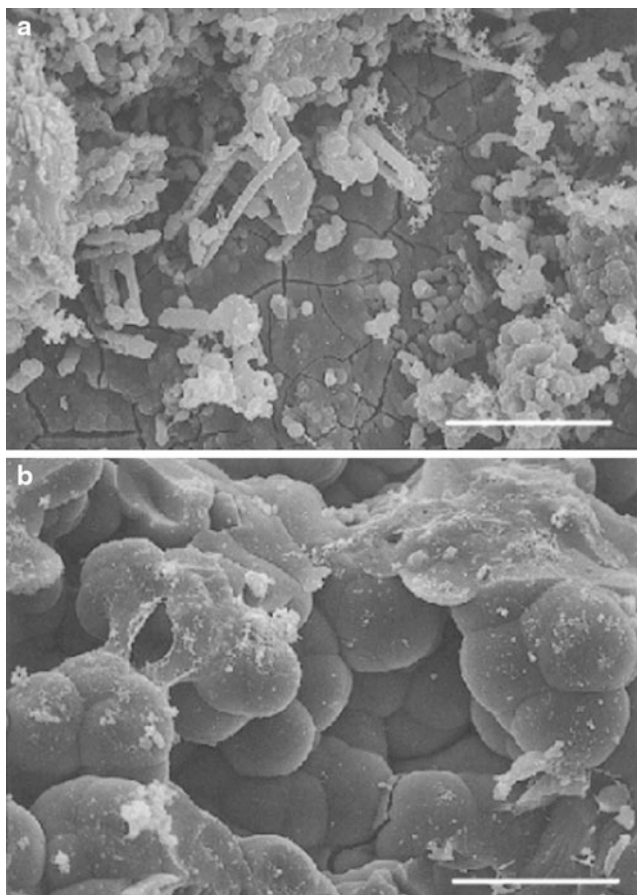

■ Fig. 12.4 Scanning electron micrographs of (a) an aerobic microbial biofilm on a stainless steel surface (bar = 10 μm) and (b) the associated corrosion products (bar = 5 μm)

The “iron bacteria” include *Sphaerotilus*, *Leptothrix*, *Gallionella*, and *Siderocapsa* (Ehrlich 1996). Ghiorse and Hirsch (Ghiorse and Hirsch 1978, 1979) also observed that two *Pedomicrobium*-like budding bacteria deposit Fe and Mn ions on their cell walls. Most of these bacteria are difficult to culture under laboratory conditions (Hanert 1981). Elucidation of their impact on corrosion is still limited by availability of culturing techniques. At neutral pH, Fe^{2+} is not stable in the presence of O_2 and is rapidly oxidized to the insoluble Fe^{3+} state. In fully aerated freshwater at pH 7, the half-life of Fe^{2+} oxidation is less than 15 min (Ghiorse 1989; Stumm and Morgan 1996). Because of the rapidity of this reaction, the only neutral pH environments where Fe^{2+} is present are interfaces between anoxic and oxic conditions.

Improved microbiological techniques permit the isolation of new Fe^{2+} -oxidizing bacteria under microaerophilic conditions at neutral pH (Emerson and Moyer 1997). Ferric oxides may be enzymatically deposited by *Gallionella ferruginea* and nonenzymatically deposited by *Leptothrix* sp., *Siderocapsa*, *Naumanniella*, *Ochrobium*, *Siderococcus*, *Pedomicrobium*, *Herpetosiphon*, *Seliberia*, *Toxothrix*, *Acinetobacter*, and *Archangium* (Ehrlich 1996; Ghiorse and Hirsch 1978). Iron-depositing bacteria include *Acholeplasma*, *Actinomyces* spp.,

Arthrobacter, *Caulococcus*, *Clonothrix*, *Crenothrix*, *Ferrobacillus*, *Gallionella*, *Hypomicrobium*, *Leptospirillum*, *Leptothrix*, *Lieskeella*, *Metallogenium*, *Naumanniella*, *Ochrobium*, *Peloploca*, *Pedomicrobium*, *Planctomyces*, *Seliberia*, *Siderococcus*, *Sphaerotilus*, *Sulfolobus*, *Thiobacillus*, *Thiopedia*, and *Toxothrix* (Ford and Mitchell 1990b). However, questions remain as to the extent of microbial involvement in specific processes of corrosion involving iron oxidation. Further investigation requires integrated approaches including microbiology, materials science, and electrochemistry.

Microorganisms in the genus *Thiobacillus* are also responsible for oxidative corrosion. Because they oxidize sulfur compounds to sulfuric acid, the acid surrounding the cells may attack alloys. Similarly, organic acid-producing microorganisms, including bacteria and fungi, are of concern. A number of acid-tolerant microorganisms are capable of Fe^0 oxidation. *Thiobacillus* is the most common. *Thiobacillus ferrooxidans* oxidizes Fe^{2+} to Fe^{3+} . However, the product limits growth of the organisms (Ehrlich 1996; Kuenen and Tuovinen 1981). Sulfate (SO_4^{2-}) is required by the Fe-oxidizing system in *T. ferrooxidans*. The role of sulfur is probably to stabilize the hexa-aquated complex of Fe^{2+} as a substrate for the Fe-oxidizing enzyme system, with the Fe^{2+} being oxidized at the surface of the bacterium. The electrons removed from Fe^{2+} are passed to periplasmic cytochrome *c*. The reduced cytochrome *c* binds to the outer plasma membrane of the cell, allowing transport of electrons across the membrane to cytochrome oxidase located in the inner membrane.

Most microorganisms accumulate Fe^{3+} on their outer surface by reacting with acidic polymeric materials. Such mechanisms have important implications not only for the corrosion of metals but also for the accumulation of heavy metals in natural habitats. *Aquaspirillum magnetotacticum* is capable of taking up complexed Fe^{3+} and transforms it into magnetite (Fe_3O_4) by reduction and partial oxidation (Blakemore 1982; Schüler and Frankel 1999). The magnetite crystals are single-domain magnets. They play an important role in bacterial orientation to the two magnetic poles of the Earth in natural environments. However, magnetite can also be formed extracellularly by some nonmagnetotactic bacteria (Lovley et al. 1987). The role of these bacteria in metal corrosion is unknown.

Manganese deposition by microorganisms also affects the corrosion behavior of alloys. Growth of *Leptothrix discophora* resulted in ennoblement of stainless steel by elevating the open-circuit potential to +375 mV (Dickinson et al. 1996, 1997). Further examination of the deposits on surfaces of coupons using X-ray photoelectron spectroscopy (XPS) confirmed that the product was MnO_2 . The MnO_2 can also be reduced to Mn^{2+} by accepting two electrons generated by metal dissolution. The intermediate product is MnOOH (Olesen et al. 1998). Manganese-depositing bacteria may include *Aeromonas*, *Bacillus*, *Caulobacter*, *Caulococcus*, *Citrobacter*, *Clonothrix*, *Cytophaga*, *Enterobacter*, *Flavobacterium*, *Hypomicrobium*, *Kuznetsovia*, *Leptothrix*, *Metallogenium*, *Micrococcus*, *Nocardia*, *Oceanospirillum*, *Pedomicrobium*, *Pseudomonas*, *Siderocapsa*, *Streptomyces*, and *Vibrio* spp.

Strictly Anaerobic Microorganisms

The sulfate-reducing bacteria are mostly responsible for corrosion under anaerobic conditions, as described earlier (and in [Fig. 12.5](#)). Currently, 18 genera of dissimilatory sulfate-reducing bacteria have been recognized (Balow et al. 1992; Campaignolle and Crolet 1997; Clapp 1948; Enos and Taylor 1996; Holland et al. 1986; Krieg and Holt 1984). They are further divided into two physiological groups (Madigan et al. 2000; Odom 1993; Odom and Singleton 1993; Postgate 1984). One group utilizes lactate, pyruvate, or ethanol as carbon and energy sources and reduces sulfate to sulfide. Examples are *Desulfovibrio*, *Desulfomonas*, *Desulfotomaculum*, and *Desulfobulbus*. The other group oxidizes fatty acids, particularly acetate, and reduces sulfate to sulfide. This group includes *Desulfobacter*, *Desulfococcus*, *Desulfosarcina*, and *Desulfonema*. Some species of *Desulfovibrio* lack hydrogenase. For example, *D. desulfuricans* is hydrogenase negative and *D. salexigens* is positive (Booth and Tiller 1960, 1962). Booth et al. (1962; 1968) observed that the rate of corrosion by these bacteria correlated with their hydrogenase activity. Hydrogenase-negative SRBs were completely inactive in corrosion. Apparently, hydrogenase-positive organisms utilize cathodic hydrogen, depolarizing the cathodic reaction, which controls the kinetics. In contrast to this theory, it has been suggested that ferrous sulfide (FeS) is the primary catalyst (Lee et al. 1995; Sanders and Hamilton 1986; Weimer et al. 1988; Westlake et al. 1986; White et al. 1986).

Other microorganisms should be noted for their role in anaerobic corrosion. They include methanogens (Daniels et al. 1987; Ferry 1995), acetogens (Drake 1994; Nozhevnikova et al. 1994), thermophilic bacteria (Ghassem and Adibi 1995; Little et al. 1986a; Torres-Sanchez et al. 1997), and obligate proton reducers (Tomei et al. 1985). More work is needed to elucidate the role of their contributions to corrosion.

Mechanisms of Microbial Corrosion

Aerobic Conditions

Iron is the most abundant element in the Earth's crust and is present in two oxidative states, ferrous (Fe^{2+}) and ferric (Fe^{3+}). Metallic iron is a product of human activity by smelting. When molecular oxygen (O_2) is available as an electron acceptor for oxidation of reduced organic compounds or metallic iron (Fe^0), the area beneath the microbial colonies acts as an anode, whereas the area further away from the colonies, where oxygen concentrations are relatively higher, serves as a cathodic site. Electrons flow from anode to cathode and the corrosion process is initiated, resulting in the dissolution of metal. Depending on the species of bacteria present and the chemical conditions, dissociated metal ions form ferrous hydroxides, ferric hydroxide, and a series of Fe-containing minerals in the solution phase. It should be noted that oxidation, reduction, and electron flow must all occur for corrosion to proceed. However, the

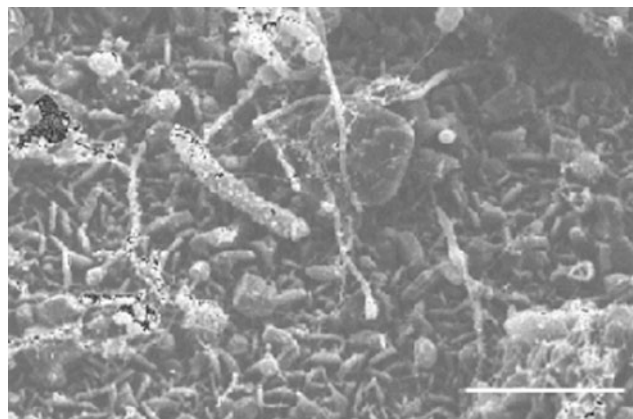
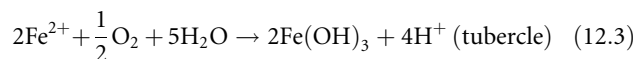
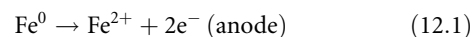

Fig. 12.5
Scanning electron micrograph of an anaerobic microbial biofilm together with corrosion products (bar = 5 μm)

electrochemical reactions never proceed at theoretical rates because the rate of oxygen supply to cathodes and removal of products from the anodes limit the overall reaction (Dowling and Guezenc 1997; Lee et al. 1993a, b; Little et al. 1990; Uhlig and Revie 1985), although the corrosion reaction is thermodynamically favorable. Electrolytes in the adjacent environments affect the resultant distance between the anode and cathode, being shorter at low salt and longer at high salt concentrations. In addition, impurities and contaminants of the metal matrices also stimulate corrosion by initiating the formation of differential cells and accelerated electrochemical reactions.

Under aerobic conditions, corrosion products usually form a typical structure consisting of three layers called “tubercles.” The inner green layer is almost entirely ferrous hydroxide ($\text{Fe}[\text{OH}]_2$). The outer one consists of orange ferric hydroxide ($\text{Fe}[\text{OH}]_3$). In between these two, magnetite (Fe_3O_4) forms a black layer (Lee et al. 1995). The most aggressive form of corrosion is tuberculation caused by the formation of differential oxygen-concentration cells on material surfaces. The overall reactions are summarized as follows:



Initial oxidation of Fe^0 of mild steel at near neutral pH is driven by dissolved O_2 (Uhlig 1971). Subsequent oxidation of Fe^{2+} to Fe^{3+} is an energy producing process carried out by a few bacterial species including *Gallionella*, *Leptothrix*, and *Thiobacillus* spp. Since the amount of free energy from this reaction is quite small for these microorganisms, approximately -31 kJ, large quantities of Fe^{2+} have to be oxidized to support the microbial growth. Because the Fe^{2+} oxidative reaction is rapid under natural conditions, microorganisms must compete with chemical processes for Fe^{2+} . As a result, biological involvement under aerobic conditions may be underestimated (Ford and Mitchell 1990a, b).

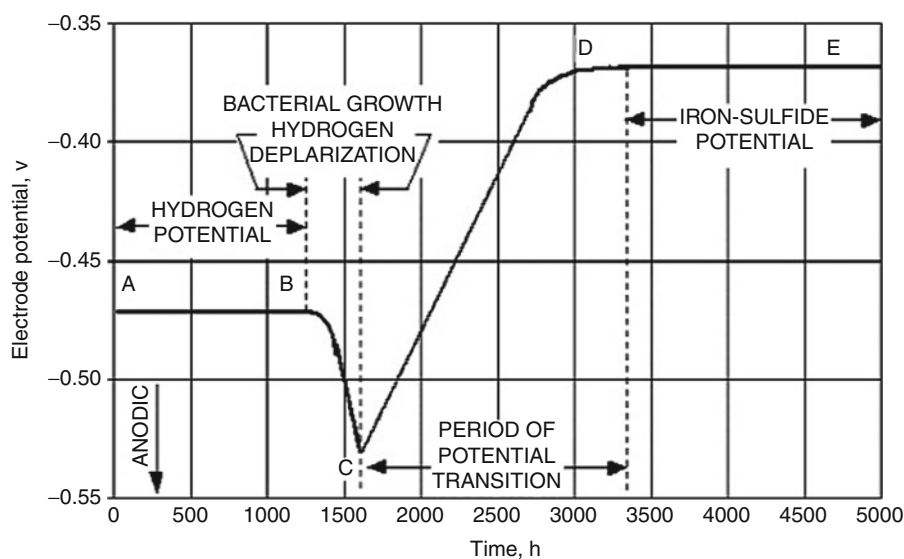

■ Fig. 12.6
Cathodic depolarization potential after inoculation of sulfate-reducing bacteria

Anaerobic Conditions

Adhesion to surfaces is a strategy microorganisms use for survival and multiplication (Marshall 1992), and it provides an opportunity leading to corrosion. In all submerged environments including freshwater and marine, surfaces are covered with microorganisms and their exopolymeric layers. Within this gelatinous matrix of a biofilm, there are oxic and anoxic zones, permitting aerobic and anaerobic processes to take place simultaneously within the biofilm layer. Aerobic processes consume oxygen, which is toxic to the anaerobic microflora, whereas anaerobes benefit from the decrease in oxygen tension. In the absence of oxygen, anaerobic bacteria including methanogens, sulfate-reducing bacteria, acetogens, and fermentative bacteria are actively involved in corrosion processes. Interactions between these microbial species allow them to coexist under conditions where nutrients are limited.

Sulfate-reducing bacteria (SRBs) are among the most intensely investigated groups of microorganisms causing biological corrosion (Angell et al. 1995; Audouard et al. 1995; Hadley 1948; Iverson 1984; Little et al. 1994; Pope et al. 1989; Starkey 1986; Walch and Mitchell 1986; Widdel 1988). Characteristic corrosion by SRBs on metal surfaces results in pitting corrosion. Since molecular oxygen is not available to accept electrons under anaerobic conditions, SO_4^{2-} or other compounds (CO_2 , H_2 , and organic acids) are used as electron acceptors. Each type of electron acceptor is unique in the pathway of microbial metabolism. When corrosion begins, the following reactions take place:

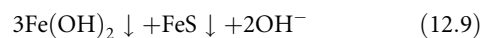
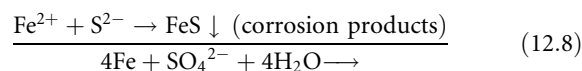
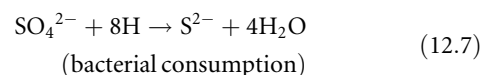
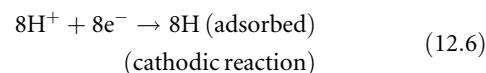
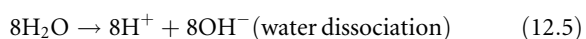
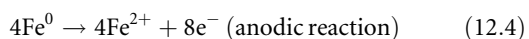

Von Wolzogen Kuhr and van der Vlugt (1934) suggested that the above set of reactions is caused by SRBs. This electrochemical generalization has been accepted and is still prevalent. During corrosion, the redox potential of the bacterial growth medium is -52 mv (Hadley 1948). After inoculation of a corrosion testing cell with SRBs, the electrochemical potential decreases from the initial value of -470 mv to approximately -538 mv (● Fig. 12.6).

Several changes take place in the electrical potential of steel after inoculation with the SRBs. Before inoculation, the value is determined by the concentration of hydrogen ions in the medium. A film of hydrogen forms on surfaces of Fe^0 and steel, inducing polarization. Immediately after inoculation, SRBs begin growth and depolarization occurs, resulting in a drop in the anodic direction. The SRBs, by means of their hydrogenase system, remove the adsorbed hydrogen, depolarizing the system. The overall process was described as depolarization, based on the theory that these bacteria remove hydrogen that accumulates on the surfaces of iron. The electron removal as a result of hydrogen utilization results in cathodic depolarization and forces more iron to be dissolved at the anode.

The direct removal of hydrogen from the surface is equivalent to lowering the activation energy for hydrogen removal by

providing a depolarization reaction. The enzyme hydrogenase, synthesized by many species of *Desulfovibrio* spp., is involved in this specific depolarization process (Starkey 1986). Under aerobic conditions, the presence of molecular oxygen serves as an electron sink; under anaerobic conditions, particularly in the presence of SRBs, SO_4^{2-} in the aqueous phase can be reduced to S_2^- by the action of the microflora. The biogenically produced S_2^- reacts with Fe^{2+} to form a precipitate of FeS. Controversy surrounding the mechanisms of corrosion includes more complex mechanisms involving both sulfide and phosphide (Iverson 1981, 1984; Iverson and Olsen 1983, 1984; Iverson et al. 1986) and processes related to hydrogenase activity (Li and Lu 1990; Starkey 1986). The addition of chemically prepared Fe_2S and fumarate as electron acceptors also depolarizes the system. However, higher rates are always observed in the presence of SRBs.

As a result of the electrochemical reactions, the cathode always tends to be alkaline with an excess of OH^- . These hydroxyl groups also react with ferrous irons to form precipitates of hydroxy iron. Precipitated iron sulfites are frequently transformed into minerals, such as mackinawite, greigite, pyrrhotite, marcasite, and pyrite. Lee et al. (Lee et al. 1993a, 1995) suggest that biogenic iron sulfides are identical to those produced by purely inorganic processes under the same conditions. Little et al. (1994) showed evidence that biogenic minerals are microbiological signature markers.

Alternation Between Aerobic and Anaerobic Conditions

Constant oxic or anoxic conditions are rare in natural or industrial environments. It is more common that the two alternate, depending on oxygen gradient and diffusivity in a specific environment. Microbial corrosion under such conditions is quite complex, involving two different groups of microorganisms and an interface that serves as a transition boundary between the two conditions. Resultant corrosion rates are often higher than those observed under either oxic or anoxic conditions. Microbial activity reduces the oxygen level at interfaces, facilitating anaerobic metabolism. The corrosion products (such as FeS, FeS_2 , and S^0) resulting from anaerobic processes can be oxidized when free oxygen is available (Nielsen et al. 1993).

During oxidation of reduced sulfur compounds, more corrosive sulfides are produced under anoxic conditions, causing cathodic reactions. The corrosion rate increases as the reduced and oxidized FeS concentrations increase (Lee et al. 1993a, b). Cathodic depolarization processes also can yield free O_2 which reacts with polarized hydrogen on metal surfaces.

Other Processes Contributing to Corrosion

Bacteria produce copious quantities of exopolymers which appear to be implicated in corrosion (Ford et al. 1986, 1987b, 1988, 1990a, b, 1991; Little and Depalma 1988; Paradies 1995; Roe et al. 1996; Whitfield 1988). The process is shown in

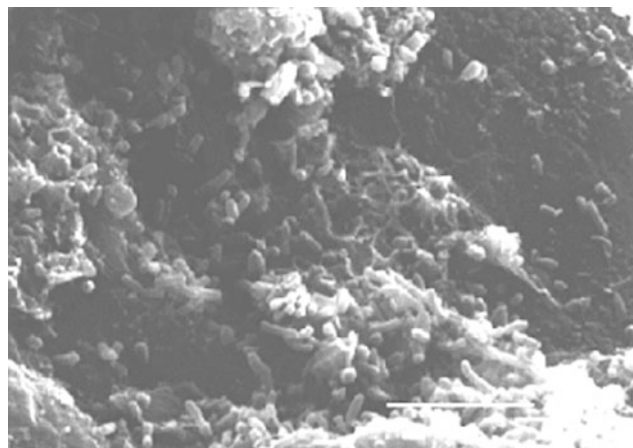

■ Fig. 12.7 Scanning electron micrograph showing a biofilm and large quantities of exopolysaccharide on the surface of stainless steel (bar = 5 μm)

● Fig. 12.7. These exopolymers are acidic and contain functional groups capable of binding to metal ions. Paradies (1995) recently reviewed this subject. The exopolymers facilitate adhesion of bacteria to surfaces. They are involved in severe corrosion of copper pipes and water supplies in large buildings and hospitals (Fischer et al. 1987; Paradies et al. 1990). Some materials also play an important role in cueing the settlement of invertebrate larvae and others in repelling larvae from surfaces (Gu et al. 1997b; Holmström et al. 1992; Maki et al. 1989, 1990a, b; Mitchell and Maki 1989; Rittschof et al. 1986). They primarily consist of polysaccharides and proteins and influence the electrochemical potential of metals (Chen et al. 1995, 1996). Surface analysis using XPS showed that these functionality-rich materials can complex metal ions from the surface, releasing them into aqueous solution. As a result, corrosion is initiated. Proteins in polymeric materials use their disulfide-rich bonds to induce corrosion.

Bacterial polymers were recently found to promote corrosion of copper pipes in water supplies (Fischer et al. 1987; Mittelman and Geesey 1985; Paradies et al. 1990), owing to the high affinity of the polymeric materials for copper ions (Mittelman and Geesey 1985; Ford et al. 1988). The corrosion processes are accelerated when the pipes are filled with stagnant soft water. Cations influence the production of bacterial exopolymers. Polysaccharide production by *Enterobacter aerogenes* is stimulated by the presence of Mg, K, and Ca ions (Wilkinson and Stark 1956). Toxic metal ions (e.g., Cr^{6+}) also enhance polysaccharide production. Synthesis is positively correlated with Cr concentration. These bacteria also can be used in the mining and recovery of precious metals, a process called “bioleaching” (Clark and Ehrlich 1992; Davidson et al. 1996; Dunn et al. 1995).

The role of bacteria in embrittlement of metallic materials by hydrogen is not fully understood. During the growth of bacteria, fermentation processes produce organic acids and molecular hydrogen. This hydrogen can be adsorbed to material

surfaces, causing polarization. Some bacteria, particularly the methanogens, sulfidogens, and acetogens, can also utilize hydrogen (Gottschalk 1986). Walch and Mitchell (1986) proposed a possible role for microbial hydrogen in hydrogen embrittlement. They measured permeation of microbial hydrogen into metal, using a modified Devanathan cell (Devanathan and Stachurski 1962). In a mixed microbial community commonly found in natural conditions, hydrogen production and consumption occur simultaneously. Competition for hydrogen between microbial species determines the ability of hydrogen to permeate metal matrices, causing crack initiation.

Microbial hydrogen involved in material failure may be explained by two distinct hypotheses: pressure and surface energy change (Borenstein 1994; Gangloff and Kelly 1994). The kinetic nature of hydrogen embrittlement of cathodically charged mild steel is determined by the competition between diffusion and plasticity. The greater the strength of the alloy, the more susceptible it is to embrittlement. However, microstructures were also proposed to be the more critical determinant of material susceptibility. Hydrogen permeation may increase the mobility of screw dislocations, but not the mobility of edge dislocations (Luu et al. 1997; Wang 1996). On the other hand, corrosion may also be inhibited by the presence of biofilms on surfaces (Hernandez et al. 1994; Jayaraman et al. 1997, 1999; Mattila et al. 1997; Potekhina et al. 1999).

Inhibition of Corrosion by Microorganisms

The mechanisms involved during microbial corrosion of metals are the following: (1) stimulation of an anodic or cathodic process by bacterial metabolites, (2) breakdown of the protective layers, and (3) enhanced conductivity near the surface liquid environment. However, bacteria may also inhibit corrosion processes (▶ Fig. 12.8) by electrochemical processes (Hernandez et al. 1994; Jayaraman et al. 1997, 1999; Mattila et al. 1997; Potekhina et al. 1999). Bacteria may also (1) neutralize the corrosive substances, (2) form protective layers on materials, or (3) decrease the corrosiveness of the aqueous environment.

Nonferrous Metals

Metals other than Fe are commonly used in alloys to inhibit corrosion and enhance mechanical properties. They include Mo, Cr, Ni, Cu, Zn, and Cd. The selection of metal species and the quantities in the iron matrices are based on the engineering properties of the materials. Pure metals in common use are limited to Fe, Al, Cu, and Ti. We know very little about biocorrosion of Al and Ti (Gu et al. 2000a). Aluminum (Al) reacts with molecular oxygen (O_2) under ambient conditions, forming an oxidized layer of protective aluminum oxide on the outer surface of the material matrix. When Al ions are released, the free Al^{3+} is toxic to both the microflora (Appanna and Piperre 1996; Illmer and Schinner 1999) and animals

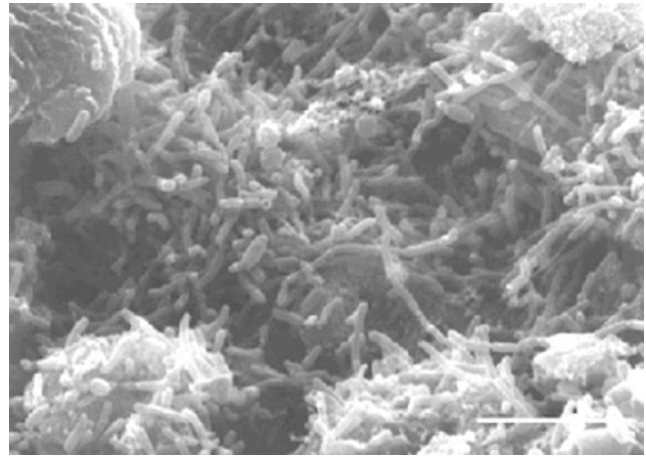

■ Fig. 12.8 Scanning electron micrograph of a bacterial biofilm of the type that is inhibiting corrosion of underlying stainless steel (bar = 5 μm)

(Nieboer et al. 1995). Because of their corrosion resistance, titanium (Ti) alloys are used in water cooling systems on ships and in water recycling systems in space. Biofilm formation on these materials has been documented (Gu et al. 1998c). However, the extent of attack by microorganisms is unknown.

Recent research on microbial interactions with metals has focused on the precipitation (Cunningham and Lundie 1993; Fortin et al. 1994), mineral formation (Bazylinski et al. 1993; Douglas and Beveridge 1998; Klaus et al. 1999), and oxidation/reduction processes (Kessi et al. 1999; Lovley and Phillips 1994; Santini et al. 2000; Stolz and Oremland 1999; Sugio et al. 1988, 1992; Tebo and Obraztsova 1998; Wang et al. 1989). Surprisingly, information on Zn, one of the most widely used metals, is very limited.

Microorganisms may affect transitional metals in several ways, including precipitation by metabolic products (Fortin et al. 1994), cellular complexation (Schembri et al. 1999; Schultzen-Lam et al. 1992), and concentration and mineral formation of internal cellular structures. Sulfate-reducing bacteria can effectively immobilize a wide range of soluble metals by forming sulfide precipitates (Sakaguchi et al. 1993). Recently, bacterial exopolymers have been found to be capable of complexing metals, leading to accumulation at the cell surface. This ability is not restricted to a specific group of microorganisms and has been documented in the aerobic bacterium *Deleya marina* and an anaerobe *Desulfovibrio desulfuricans* (Chen 1996a). Since many transitional metals exist in several oxidation/reduction states, both bacterial oxidation and reduction are possible.

Chromium (Cr) can exist in either the hexavalent or trivalent form. Reduction of Cr^{6+} to Cr^{3+} is mediated by both aerobic and anaerobic microorganisms. A change of phenotypic expression in *Pseudomonas indigofera* (*Vogesella indigofera*) has been observed in the presence of Cr^{6+} (Gu and Cheung 2001). Intracellular partition of Cr was reported using bacteria from a subsurface environment. Reduction of Cr^{6+} is a

process in which the toxicity of the metal is greatly reduced. Bacteria possessing this ability include *Achromobacter eurydice*, *Aeromonas dechromatica*, *Agrobacterium radiobacter*, *Arthrobacter* spp., *Bacillus subtilis*, *B. cereus*, *Desulfovibrio vulgaris*, *Escherichia coli*, *Enterobacter cloacae*, *Flavobacterium devorans*, *Sarcina flava*, *Micrococcus roseus*, and *Pseudomonas* spp. (Ehrlich 1996).

Similarly, Mo exists in a number of oxidation states, with Mo^{4+} and Mo^{6+} being most common. *Thiobacillus ferrooxidans* is capable of oxidizing Mo^{5+} to Mo^{6+} , whereas *Enterobacter cloacae*, *Sulfolobus* sp., and *Thiobacillus ferrooxidans* can reduce Mo^{6+} to Mo^{5+} (Sugio et al. 1988, 1992). Microbiological oxidation or reduction of other metals, including Cd, Ni, and Zn, has not been fully established. Microbial exopolymers have a significant effect on the solubilization of metals from material matrices through complexation and chelation. Because of this property, wastewater containing these metal ions can be purified through biomass adsorption, a process in which metal ions are concentrated on a biosorbent (Gelmi et al. 1994; Matis et al. 1996; Sánchez et al. 1999).

Our knowledge of microbial transformation of metals is very limited. Recent developments in isolation of Bacteria and Archaea may provide new tools to investigate metal transformations in natural habitats (Amann et al. 1995). Molecular techniques, including DNA probes and in situ hybridization, permit the identification of physiologically unique bacteria without the need to culture the organisms. Microbial resistance to metals is widespread in nature (Lin and Olsen 1995; Mergeay 1991; Sandaa et al. 1999). Elucidation of the genetic structure of these bacteria should provide new insights into the processes involved in resistance.

Biodeterioration of Polymeric Materials

Microorganisms also contribute to the deterioration and degradation of synthetic and natural polymers (Lee 1948; Gu et al. 2000d). Very little is known about the biodegradation of synthetic polymeric materials, probably because of their relatively recent widespread use and very slow rate of degradation in natural habitats. Since chemically synthesized polymeric materials have become an indispensable part of human activities and have more diversified applications than metals, issues related to polymer deterioration will receive more attention in the future.

Polymeric materials are very diversified in their chemical composition, physical forms, mechanical properties, and applications. Variations in their chemical structure result from the versatility of the hydrocarbon (C—C, C—R, and C—H) bonds and substituent groups and their possible configurations, stereochemistry, and orientation (Odian 1991). These small variations in structure result in large differences in biodegradability. Because of their versatility, they are widely used in product packaging, insulation, structural components, protective coatings, medical implants, drug delivery carriers, slow-release capsules, electronic insulation, telecommunications equipment, aviation and space industry applications, sporting and

recreational equipment, and building consolidants. In service, they are constantly exposed to a range of natural and artificial conditions often involving microbial contamination, resulting in aging, disintegration, and deterioration over time (Lemaire et al. 1992; Pitt 1992).

Microorganisms and Degradation of Synthetic Polymers

Polymers are potential substrates for heterotrophic microorganisms. Microbial utilization of polymers depends on their chemical structure, molecular weight, crystallinity, and physical form (Gu et al. 2000d). Generally, an increase in molecular weight results in a decreased degradation rate of the polymer. By contrast, monomers, dimers, and oligomers of a polymer's repeating units are easily degraded and mineralized. High molecular weights result in a decrease in solubility and are unfavorable for microbial attack because bacteria require that the substrate be assimilated through the cellular membrane and then further degraded by intercellular enzymes. Both abiological and biological processes may facilitate degradation of polymers.

At least two types of enzymes are active in biological degradation of polymers: extracellular and intracellular depolymerases (Doi 1990). During degradation, exoenzymes from microorganisms break complex polymers to yield short units including oligomers, dimers, and monomers that are small enough to pass through permeable outer bacterial membranes and subsequently be utilized as carbon and energy sources (▶ Fig. 12.9). The more similar a polymeric structure is to a natural analog, the more easily it is degraded and mineralized. Cellulose, chitin, pullulan, and poly β -hydroxybutyrate (PHB) are all biologically synthesized and can be completely and rapidly biodegraded by heterotrophic microorganisms (Bérenger et al. 1985; Byrom 1991; Chahal et al. 1992; Frazer 1994; Gamerith et al. 1992; Gujer and Zehnder 1983; Gunjala and Sulflita 1993; Hamilton et al. 1995; Hass et al. 1992; Hespell and O'Bryan-Shah 1988; Kormelink and Voragen 1993; Lee et al. 1985, 1987a, b, 1993c; Lüthi et al. 1990a; Lüthi et al. 1990b; MacDonald et al. 1985; MacKenzie et al. 1987; Nakanishi et al. 1992; Sonne-Hansen et al. 1993; Sternberg et al. 1977; Törrönen et al. 1993; Wong et al. 1988; Yoshizako et al. 1992). The complete decomposition of a polymer to CO_2 and H_2O under aerobic conditions or to organic acids, CO_2 , and CH_4 under anaerobic conditions is rare. Degradation and mineralization of a polymer substrate rarely are complete because of the utilization of a portion of the partially degraded polymer to form humus and other natural products (Alexander 1977; Narayan 1993).

Environmental conditions may determine the dominant groups of microorganisms and the degradative pathways associated with polymer degradation. Under high redox conditions, aerobic microorganisms are mostly responsible for destruction of complex materials, with microbial biomass, CO_2 , and H_2O as the final products (▶ Fig. 12.9). In contrast, under low redox conditions, anaerobic consortia of microorganisms are involved in polymer deterioration, and the primary products will be

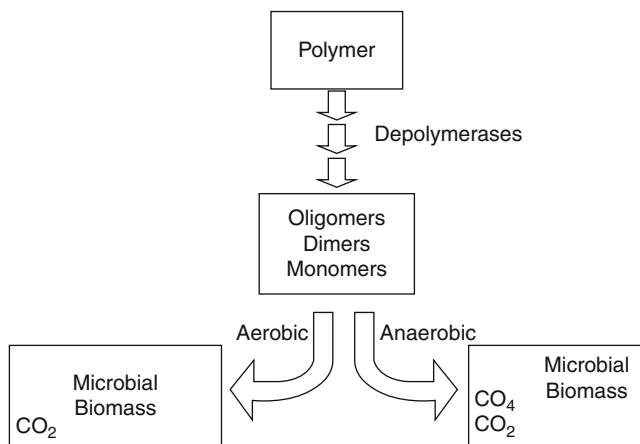

■ Fig. 12.9
A schematic of polymer degradation under aerobic and anaerobic conditions

microbial biomass, CO_2 , CH_4 , and H_2O (Barlaz et al. 1989a; Barlaz et al. 1989b; Gu et al. 2000d, e; ► Fig. 12.9). These conditions are widely found in natural environments and can be simulated in the laboratory with appropriate inocula. Both aerobic and strictly anaerobic microorganisms also coexist in natural environments.

We can divide synthetic polymers into three groups: (1) relatively degradable, (2) recalcitrant, and (3) completely resistant. We have excluded natural polymers, e.g., cellulose, chitin, chitosan, lignin, and polysaccharides.

Degradable Polymers

Microbial degradability of polymers depends on their molecular composition and molecular weight. Some can be almost completely utilized as a source of carbon and energy, whereas others are only partially degraded. Examples of the former include the polyhydroxyalkanoates (PHAs; Anderson and Dowes 1990; Brandl et al. 1988; Choi and Yoon 1994; Doi 1990; Nakayama et al. 1985; Stenbüchel 1991; Stuart et al. 1995; Tanio et al. 1982), γ -polyglutamates (Cromwick and Gross 1995), cellulose acetates (Buchanan et al. 1993; Gross et al. 1993, 1995; Gu et al. 1992b, c, 1993a, b, c, 1994b), polyethers (Kawai 1987; Kawai and Moriya 1991; Kawai and Yamanaka 1986), polylactides (Gu et al. 1992b, c), polyurethanes (Blake et al. 1998; Crabbe et al. 1994; El-Sayed et al. 1996; Filip 1978; Gillatt 1990; Gu et al. 1998c; Mitchell et al. 1996; Nakajima-Kambe et al. 1995; Szycher 1989), and rubbers (Berekaa et al. 2000; Heisey and Papadatos 1995). A general rule is that biologically synthesized polymers are readily biodegradable in natural environments, whereas synthetic polymers are either less biodegradable or degrade very slowly, depending on their chemical composition, structural complexity, and molecular weights. However, the rate of degradation is largely determined by the chemical structure, e.g., the C—C and other types of bonds, molecular weight, structure and configuration, as well as the

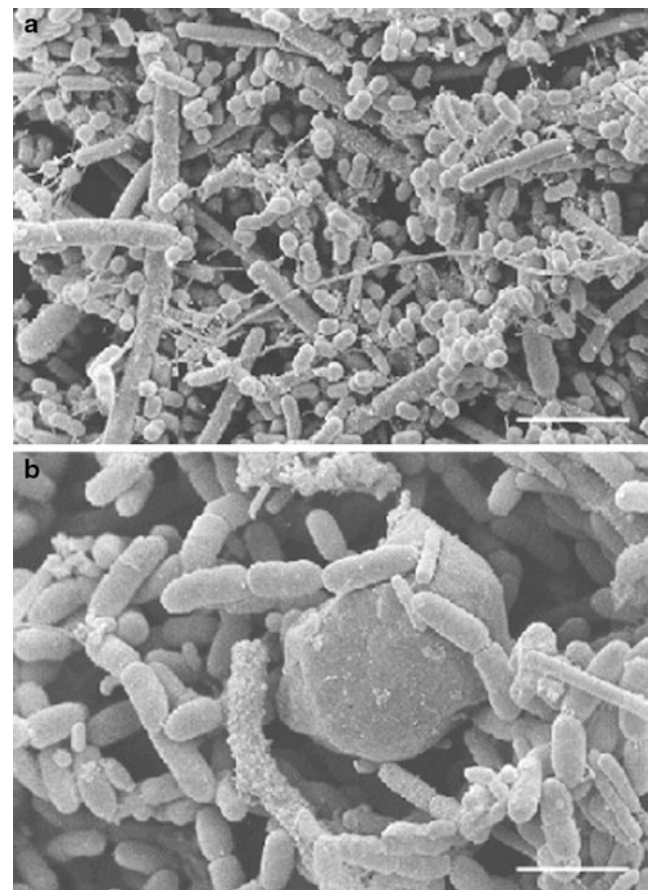

■ Fig. 12.10
Scanning electron micrographs of (a) an aerobic microbial biofilm on the surface of poly- β -hydroxybutyrate (PHB; bar = 10 μm) and (b) bacteria surrounding a PHB granule (bar = 5 μm)

participating microorganisms. It is also determined by the environment, specifically the presence of an active microbial population capable of utilizing all or part of the polymer.

Chemical structure of a polymer determines its biodegradability. As a general rule, high molecular weight synthetic polymers are less biodegradable or degrade at a slower rate than those with low molecular weights. The same principal may also apply to the polymers mentioned above. In addition, the rate of hydrolytic chain cleavage is dependent on the copolymer composition. For example, Doi (1990) determined that the most susceptible polyhydroxybutyrate to hydrolysis (from highest to lowest hydrolysis rate) are the following: poly(3-hydroxybutyrate-co-27 % 4-hydroxybutyrate), also known as (P[3HB-co-27 % 4HB]) > (P[3HB-co-17 % 4HB]) > (P[3HB-co-10 % 4HB]) > poly(3-hydroxybutyrate-co-45 % 3-hydroxyvalerate), also known as (P[3HB-co-45 % 3HV]) > (P[3HB-co-71 % 3HV]). Similarly, Parikh et al. (1993) in another series arranged PHBs in the order of their rates (from highest to lowest) of enzymatic hydrolysis as follows: (P[HB-co-16 % HV]) > (P[HB-co-32 % HV]) > PHB (► Fig. 12.10). The crystallinity of the polymer also affects the rate of degradation but is rarely taken into account (Budwill et al. 1992).

Biopolymers

Bacterial poly(β -hydroxyalkanoates) are formed as energy storage materials during nutrient-limited growth when the carbon source is in excess, e.g., high C/N ratio (Anderson and Dawes 1990; Brandl et al. 1988; Doi 1990; Holmes et al. 1985; Kim et al. 1995; Lemoigne 1926; Stenbüchel 1991). They consist of homo- or copolymers of [R]- β -hydroxyalkanoic acids. The polymer forms intracellular inclusions (granules 0.3–1.0 μm in diameter) in the bacterial cytoplasm, and it can comprise as much as 30–80 % of cellular biomass. The polymer is isolated from *Bacillus megaterium* by extraction in chloroform and has a molecular weight of approximately 10^5 – 10^6 with more than 50 % in crystalline form (Gu et al. unpublished observation). Unlike other biopolymers, such as polysaccharides, proteins, and DNAs, P(3HB) is a thermoplastic with a melting temperature around 180 $^{\circ}\text{C}$, making it a good candidate for thermoprocessing. Poly- β -hydroxyalkanoates (PHAs) and copolymers have also been produced through genetic engineering in plants (John and Keller 1996) and by chemical synthesis (Kemnitzner et al. 1992, 1993).

Homopolymers and copolymers can be degraded in biologically active environments, e.g., soil (Albertsson et al. 1987; Mas-Castellà et al. 1995; Tsao et al. 1993), sludge, compost (Gilmore et al. 1992, 1993; Gross et al. 1993, 1995; Gu et al. 1993b), river water (Andrady et al. 1993; Iman et al. 1992), and seawater (Andrady et al. 1993; Sullivan et al. 1993; Wirsén and Jannasch 1993). Extracellular P(HB) depolymerases have been isolated from *Pseudomonas lemoignei* (Lusty and Doudoroff 1966) and *A. faecalis* (Saito et al. 1989; Tanio et al. 1982). Other bacteria capable of degrading these polymers include *Acidovorax facilis*, *Variovorax paradoxus*, *Pseudomonas syringae* subsp. *savastanoi*, *Comamonas testosteroni*, *Cytophaga johnsonae*, *Bacillus megaterium*, *B. polymyxa*, and *Streptomyces* spp. (Mergaert et al. 1993). The enzymatic degradation occurs at the surfaces of the polyester film (► Fig. 12.11), and the rate of surface erosion is highly dependent on the molecular weight (degree of polymerization), composition of the polyester, crystallinity, and the dominant species of bacteria.

Chemically Modified Biopolymers

Cellulose acetates (CAs) are a class of chemically modified natural polymers designed to improve their processibility and mechanical properties for different applications (Bogan and Brewer 1985). Theoretically, they carry substitution values from as low as near zero to 3.0. Generally, CAs with a degree of substitution less than 2.5 have been shown to be degraded in thermophilic compost (Gross et al. 1993, 1995; Gu et al. 1992b, c; 1993a, b, c, 1994b) or transformed through biologically catalyzed reactions (Downing et al. 1987). Increasing the degree of substitution (DS) value on a repeating unit makes the CA less degradable. It is also apparent that deviation from the natural structure increases resistance of degradation.

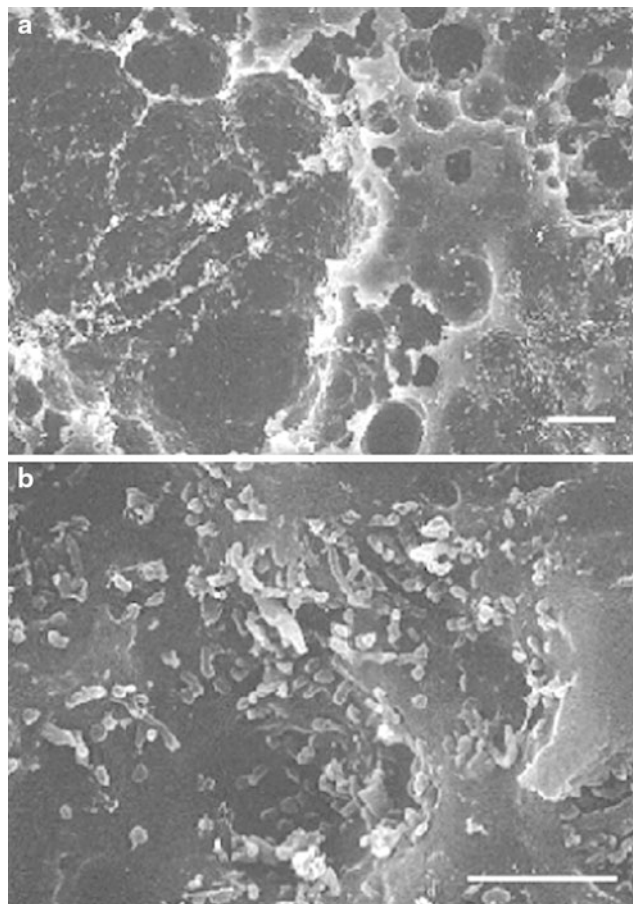

■ Fig. 12.11 Scanning electron micrographs showing (a) extensive surface erosion by surface-colonizing bacteria in soil (bar = 1 μm) and (b) a close-up of the eroded area (bar = 5 μm)

Cellulose acetate (CA) degradation occurs more rapidly under aerobic conditions. The mechanisms of degradation are deacetylation, which releases the substituted groups, followed by cleavage of the C–C backbone. It is believed that the molecular weight decrease and deacetylation proceed simultaneously during degradation, after CA reaches a critical value of substitution. Structural substitution groups, and their number per repeating unit, also affect the degradation kinetics. For example, cellulose acetates (CAs) with lower degree of substitution (DS) values are more quickly degraded than more substituted ones under both aerobic and anaerobic conditions (Buchanan et al. 1993; Gross et al. 1993, 1995, 1992c, Gu et al. 1992d, 1992c, 1993a, b, c, b). Cellulose acetates (CAs) with lower substitution values also show relatively higher solubility. During degradation of CA, both molecular weight and degree of substitution decreased, suggesting that deacetylation and decomposition of the polymer backbone proceed simultaneously (Gu et al. 1993c). Earlier data suggested that CA with DS values greater than 0.82 is recalcitrant to biodegradation and that the limiting step is deacetylation, followed by breaking of the polymer carbon–carbon bonds (Reese 1957). Obviously, degradation of CA can proceed at DS values higher than 0.82.

Chemically Synthesized Polymers

The most common group of synthetic polymers is polyethers. These polymers include polyethylene glycols (PEGs), polypropylene glycols (PPGs), and polytetramethylene glycols (PTMGs). They are widely used in pharmaceuticals, cosmetics, lubricants, inks, and surfactants. They frequently contaminate natural waters, including coastal waters and streams where wastewater is discharged.

Degradability of this class of polymers has been studied under both oxic (Kawai and Moriya 1991; Kawai and Yamanaka 1986; Kawai 1987) and anoxic conditions (Frings et al. 1992; Schink and Stieb 1983; Dwyer and Tiedje 1983). Their degradability is dependent on molecular weight. Molecules with molecular weights higher than 1,000 have been considered resistant to biodegradation (Kawai 1987). However, degradation of PEGs with molecular weights up to 20,000 has been reported. The ability of a microflora to degrade larger PEG molecules is dependent primarily on the ability of a syntrophic association of bacteria to metabolize the chemicals. For example, *Flavobacterium* and *Pseudomonas* (acting in concert) can degrade PEG. After each oxidation cycle, PEG molecules are reduced by a glycol unit.

The central theme of PEG degradation is cleavage of an aliphatic ether linkage. In a coculture of aerobic *Flavobacterium* and *Pseudomonas* species, PEG degradation proceeds through dehydroxylation to form an aldehyde and continues through a dehydrogenation to a carboxylic acid derivative (Kawai 1987; Kawai and Yamanaka 1986). Either of these bacteria in pure culture cannot degrade PEG alone. Cellular contact between them seems to be essential for effective activity.

In the *Flavobacterium* and *Pseudomonas* system, three enzymes (PEG dehydrogenase, PEG-aldehyde dehydrogenase, and PEG-carboxylate dehydrogenase) are involved in the complete degradation of PEG (Kawai 1987). All three were found in *Flavobacterium*, whereas only PEG-carboxylate dehydrogenase was present in *Pseudomonas*. The polymer PEG 6000 cannot be degraded by either bacterial species alone. The ether cleavage is extremely sensitive to the presence of glyoxylic acid. However, *Pseudomonas*, though not directly involved in the degradation, utilizes the toxic metabolite that inhibits the activity of the *Flavobacterium*. This appears to be the essential link for their syntrophic association in the degradation of PEG.

Recalcitrant Polymers

Electronic Insulation Polymers

Generally, polymers in this category are chemically synthesized with the objective of high strength and resistance to degradation. They include thermosetting polyimides (Brown 1982; Ford et al. 1995; Gu et al. 1994a, 1995a, 1996b, e, 1998b, c; Mitton et al. 1993, 1996, 1998), corrosion protective coatings (Mitchell et al. 1996), and fiber-reinforced polymeric composites (Gu et al. 1994a, 1995a, b, c, d, 1996a, c, e, 1997a, b; Wagner 1995; Wagner et al. 1996). Wide acceptance of polyimides in the electronics

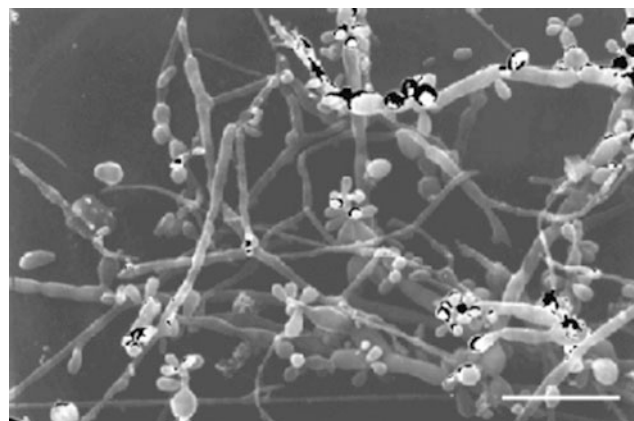

■ Fig. 12.12
Scanning electron micrograph showing a fungal community growing on the surface of electronic insulation polyimides (bar = 10 μm)

industry (Brown 1982; Jensen 1987; Lai 1989; Verbicky 1988; Verbiest et al. 1995) has drawn attention to the stability of these materials. The National Research Council in 1987 (NRC 1987) emphasized the need to apply these polymers in the electronics industries because data acquisition, information processing, and communication are critically dependent on materials performance. The interlayering of polyimides and electronics in integrated circuits prompted several studies on the interactions between these two materials (Hahn et al. 1985; Kelley et al. 1987).

Polyimides are also widely used in load-bearing applications (e.g., struts, chassis, and brackets in automotive and aircraft structures), owing to their flexibility and compressive strength. They are also used in appliance construction, cookware, and food packaging because of their chemical resistance (to oils, greases, and fats), microwave transparency, and thermal resistance. Their electrical properties are ideally suited for use in the electrical and electronics markets, especially as high temperature insulation materials and passivation layers in the fabrication of integrated circuits and flexible circuitry. In addition, the flammability resistance of this class of polymers may provide a halogen-free flame-retardant material for aircraft interiors, furnishings, and wire insulation. Other possible uses may include fibers for protective clothing, advanced composite structures, adhesives, insulation tapes, foam, and optics operating at high temperatures (Verbiest et al. 1995).

Electronic packaging polyimides are particularly useful because of their outstanding performance and engineering properties. However, they are susceptible to degradation by fungi (Ford et al. 1995; Gu et al. 1994a, 1995a, 1996b; Mitton et al. 1993, 1998; ► Fig. 12.12).

Polyimide degradation occurs through biofilm formation and subsequent physical changes in the polymer. Using electrochemical impedance spectroscopy (EIS) (Mansfeld 1995; van Westing et al. 1994), fungi growing on polyimides have been shown to yield distinctive EIS spectra, indicative of failing resistivity. Two steps are involved during degradation: an initial

decline in coating resistance is related to the partial ingress of water and ionic species into the polymer matrices. This is followed by further deterioration of the polymer by activity of the fungi, resulting in a large decrease in resistivity. The data support the hypothesis that polyimides are susceptible to microbial degradation resulting in the corrosion of underlying metal. They also confirm the versatility of EIS as a method in evaluation of the biosusceptibility of polymers.

Our studies showed that the dielectric properties of polyimides could be altered drastically following growth of a microbial biofilm (Ford et al. 1995; Gu et al. 1995a, 1996b; Mitton et al. 1993, 1998). This form of deterioration may be slow under ambient conditions. However, the deterioration processes can be accelerated in humid conditions or in enclosed environments, e.g., submarines, space vehicles, aircraft, and other closed facilities. Very small changes in material properties may have serious consequences.

Fiber-Reinforced Polymeric Composite Materials

Fiber-reinforced polymeric composite materials (FRPCMs) are also susceptible to biological attack. Impurities and additives that can promote microbial growth are potential sources of carbon and energy for the microorganisms (► Fig. 12.13). Recently, two groups reported microbial degradation of FRPCMs (Gu and Mitchell 1995; Gu et al. 1995b, c, d, 1996c, e, 1997a, b; Wagner et al. 1996). Wagner and her collaborators (Wagner et al. 1996) used a mixed culture of microorganisms including a sulfate-reducing bacterium. Gu and colleagues (Gu et al. 1994a, 1996b, c, e, 1997a, b) used a fungal consortium originally isolated from degraded polymers. This consortium consisted of *Aspergillus versicolor*, *Cladosporium cladosporioides*, and a *Chaetomium* sp. Physical and mechanical tests were not sufficiently sensitive to detect any significant physical changes in the materials (Gu et al. 1997a; Thorp et al. 1994). However, the resins were actively degraded, indicating that the materials were at risk of failure.

The increasing usage of FRPCMs as structural components of public structures and aerospace applications has generated an urgent need to evaluate the biodegradability of this class of new material. It has become clear that FRPCMs are not immune to adhesion by microorganisms (Ezeonu et al. 1994b; Gu et al. 1998c; Mitchell et al. 1996).

Recently, natural populations of microorganisms were found capable of growth on surfaces of FRCPM coupons at both relatively high (65–70 %) and lower humidity (55–65 %; Gu et al. 1998c). The accumulation of bacteria on surfaces of composites develops into a biofilm layer, providing some initial resistance to further environmental changes. However, the resistivity of composite materials was found to decline significantly during a year of monitoring using EIS (Gu et al. 1996e, 1997a). Clear differences resulting from biofilm development were detected on FRPCMs used in aerospace applications (Gu et al. 1997a). Further study indicated that microorganisms utilize chemicals

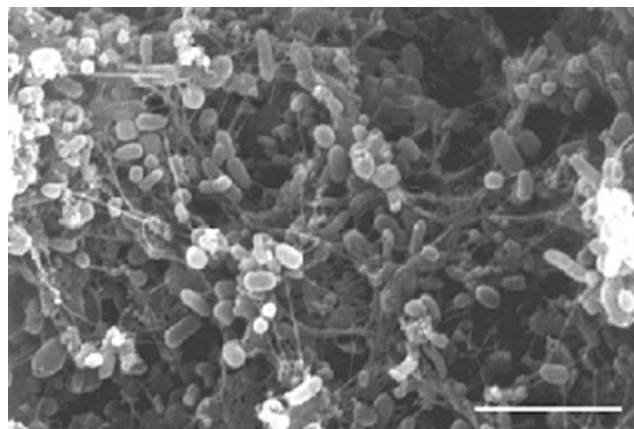

■ Fig. 12.13 Scanning electron micrograph of microorganisms colonizing the surface of a fiber-reinforced polymeric composite (bar = 10 μ m)

introduced during composite manufacture as carbon and energy sources (Gu et al. 1996c). Lignopolystyrene graft copolymers were also susceptible to attack by fungi (Milstein et al. 1992).

A critical question remains about the effect of FRCPM degradation on the mechanical properties of the composite materials. Thorp et al. (1994) attempted to determine mechanical changes in composite coupons after exposure to a fungal culture. No mechanical changes could be measured after 120 days of exposure. They suggested that methodologies sufficiently sensitive to detect surface changes need to be utilized. Acoustic techniques also have been proposed as a means of detecting changes in the physical properties of the composite (Wagner et al. 1996).

Corrosion Protective Coatings

Polymeric coatings are designed to prevent contact of the underlying materials with corrosive chemicals and microorganisms. However, microbial degradation of coatings may accelerate and severely damage the underlying metals. Natural bacterial populations were found to readily form microbial biofilms on surfaces of coating materials, including epoxy and polyamide primers and aliphatic polyurethanes (Blake et al. 1998; Gu et al. 1998c; Thorp et al. 1997; ► Fig. 12.14). Surprisingly, the addition of biocides to polyurethane coatings may not inhibit bacterial attachment or growth of bacteria (Gu et al. 1998c; Mitchell et al. 1996).

Using EIS, both primers and top-coatings were monitored for their response to biodegradation by fungi. Results indicated that primers are more susceptible to degradation than are top-coats (Gu et al. 1998c).

Nondegradable Polymers

Polyethylenes (PEs) of high and low density are primarily used in product packaging as sheets and thin films.

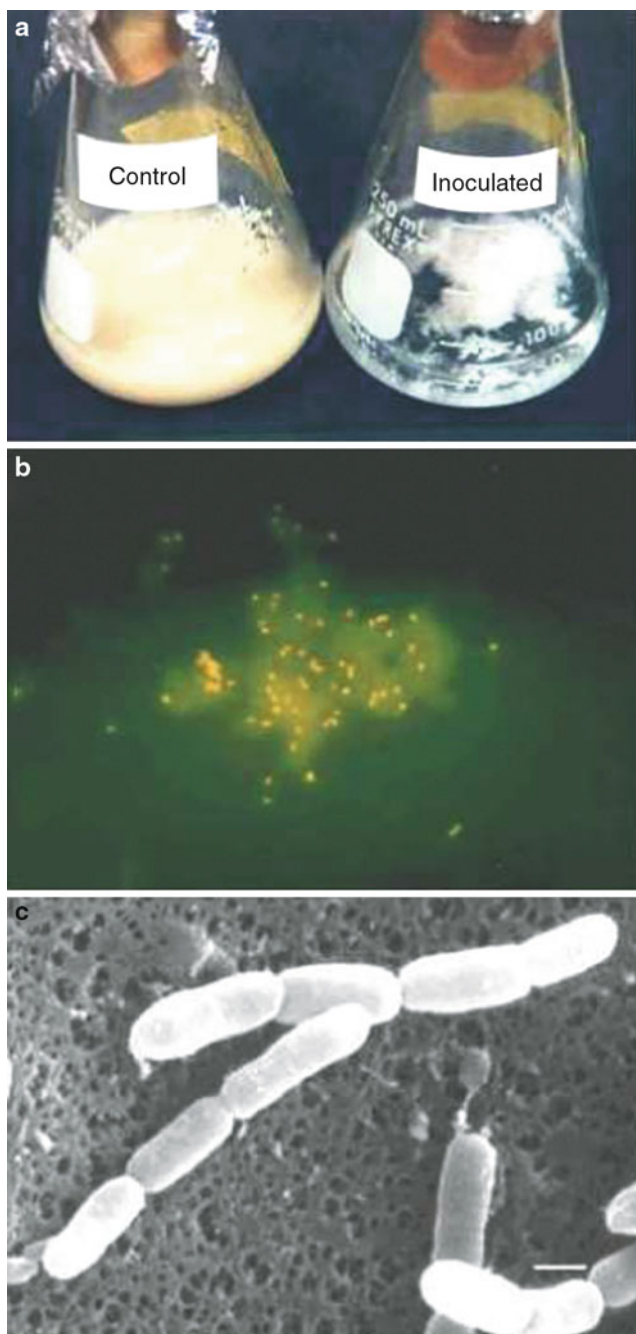

■ Fig. 12.14

A polyurethane-degrading bacterium isolated and in pure culture. (a) Photograph shows clearing in the inoculated flask and a homogeneous emulsion in the control flask. (b) An epifluorescence photomicrograph of the precipitated materials from the inoculated flask shows surface-associated bacteria (magnification 1,300 \times), and (c) a scanning electron micrograph shows a bacterium capable of degrading polyurethane in pure culture ($bar = 1 \mu m$)

Their degradability in natural environments poses serious environmental concerns, owing to their slow degradation rate under natural conditions and the hazard they present to freshwater and marine animals. Biodegradation of PEs has been studied

extensively (Albertsson 1980; Breslin 1993; Breslin and Swanson 1993; Iman and Gould 1990). Prior exposure of PEs to UV promotes polymer degradation. It is believed that polymer additives, such as starch, antioxidants, coloring agents, sensitizers, and plasticizers, may significantly alter the biodegradability of the parent polymers (Karlsson et al. 1988). Degradation rates may be increased by 2–4 % following photosensitizer addition. However, degradation is very slow (estimated in decades). Crystallinity, surface treatment, additives, molecular weight, and surfactants are all factors affecting the fate and rate of PE degradation, and they may accelerate the process.

In one study, extracellular culture concentrates of three *Streptomyces* species were inoculated to starch-containing PE films (Pometto et al. 1992, 1993). It was claimed that the PE was degraded. However, degradation may have been minimal. Other data describing degradation of PE-containing starch are questionable. Microbial metabolites may contaminate the PE surfaces and could be interpreted as degradation products of the parent PE. Abiotic degradation of PE is evident by the appearance of carbonyl functional groups in abiotic environments. In contrast, an increase of double bonds was observed when polymers showed weight loss resulting from biodegradation (Albertsson et al. 1994). It was proposed that microbial PE degradation is a two-step process: an initial abiotic photooxidation followed by a cleavage of the polymer carbon backbone. However, the mechanism of the second step needs extensive analysis before plausible conclusions can be drawn. Lower molecular weight PEs including paraffin can be biodegraded. Paraffin undergoes hydroxylation oxidatively to form an alcohol group, followed by formation of carboxylic acid. At higher temperatures, ketones, alcohols, aldehydes, lactones, and carboxylic acids are formed abiotically in six weeks (Albertsson et al. 1994). Polyethylene (PE) pipes used in gas distribution systems may fail because of cracking. It is unlikely that biological processes are involved (Zhou and Brown 1995).

Polypropylenes (PPs) are also widely utilized in engineering pipes and containers. Degradation of PPs results in a decrease of their tensile strength and molecular weight. The mechanism may involve the formation of hydroperoxides which destabilize the polymeric carbon chain to form a carbonyl group (Cacciari et al. 1993; Severini et al. 1988). Degradability of pure and high molecular weight PPs is still an open question.

Corrosion of Concrete and Stone

Concrete and stone are the most widely used materials in construction and infrastructures. Biodeterioration of these materials has important economic consequences, especially when replacement or repair of infrastructures such as bridges or municipal sewer systems is involved (Biczok 1968; Diercks et al. 1991; Ford 1993; Mansfeld et al. 1990; Sand and Bock 1984; Sand et al. 1983, 1987, 1991; Yao and Li 1995). In addition, biodeterioration plays an important role in deterioration of stone in historic buildings, monuments, and archaeological sites (Arino et al. 1997; Bianchi et al. 1980; Bock et al. 1989;

Cariola et al. 1987; Danin 1993; Feddema and Mererding 1991; Garcia de Miguel et al. 1995; Kumar and Venkataraman 1996; Mitchell and Gu 2000; Ortega-Calvo et al. 1993, 1995; Tiano 1993; Tomaselli et al. 2000; Urzi and Realini 1998). Degradation of these materials is a complex phenomenon involving chemical, physicochemical, electrochemical, and biological processes (Ascaso et al. 1998). Microorganisms have been implicated for many years (Dutton and Evans 1996; Ezeonu et al. 1994a; Parker 1945a, b), but their involvement is poorly understood. Bacteria in the genus *Thiobacillus* were initially identified as the major culprits through biologically produced sulfuric acid, resulting in dissolution of materials. Other chemolithotrophs have been implicated in the deterioration process, including inorganic acid-producing (Atlas and Bartha 1997; Jazsa et al. 1996a, b; Sand et al. 1991), organic acid-producing (Gu et al. 1996a, 1998a), and exopolymer-producing bacteria (Freeman and Lock 1995; Gehrke et al. 1998; Gu et al. 1996a, 1998a). Macroscopic organisms, invertebrates in particular, also participate in degradation of concrete in submerged structures, but no detailed study has been reported.

As early as 1900, corrosion of concrete sewer pipes was detected by Olmstead and Hamlin (1900). Hydrogen sulfide, an anaerobic decomposition product of sulfur-containing organic compounds and reduction of SO_4^{2-} in wastewater during microbial metabolism, was identified as the cause of corrosion (Fig. 12.15). The corrosion reaction was initially regarded as a purely chemical process (Lea and Desch 1936), in which hydrogen sulfite produced under anaerobic conditions in wastewater is oxidized chemically to sulfuric acid in the presence of oxygen (Biczok 1968). The sulfuric acid then reacts with calcium in concrete to form CaSO_4 or gypsum. Parker and his coworkers established the relationship between acidophilic thiobacilli and concrete degradation by isolating *Thiobacillus concretivorus* (renamed "*Thiobacillus thiooxidans*") and another *Thiobacillus* species from corroded concrete (*T. neopolitabus*; Parker 1945a, b, 1947; Parker and Jackson 1965; Parker and Prisk 1953). The extent of corrosion correlates positively with the population of these microorganisms.

In the early 1980s, rapid deterioration of newly replaced sewer systems in Hamburg, Germany, renewed interest in the corrosion processes (Milde et al. 1983; Sand and Bock 1984; Sand et al. 1983, 1987, 1991). In these investigations, positive correlations were observed between the extent of concrete corrosion and the numbers of *T. thiooxidans*. Sand (Sand 1987, 1997) also observed that *T. ferrooxidans* was associated with oxidative activity of H_2S . In the presence of sodium thio-sulfate, the dominant microorganisms were *T. neapolitanus*, *T. intermedius*, and *T. novellus*.

Biological corrosion of sewer pipes can be a serious problem in coastal cities, owing to the abundance of SO_4^{2-} in the wastewater. At the time of the Hamburg failure, coastal cities in the United States faced similar problems with newly installed concrete sewer systems, especially the city of Los Angeles (Mansfeld et al. 1990; Morton et al. 1991). A reason for the reemergence of the problem was the advent of the National Pollution Discharge Elimination Systems (NPDES) in 1972, which bans discharge of

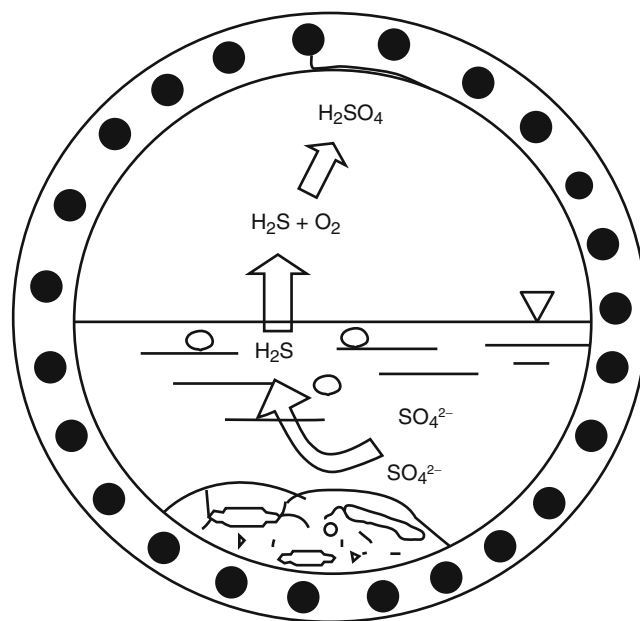

■ Fig. 12.15
A schematic of concrete corrosion by bacteria

toxic metals and chemicals into sewers. As a result of this legislation, inorganic and organic toxic wastes were no longer permitted to be discharged directly to sewers, with a resultant increased activity of microorganisms producing large quantities of H_2S (Bitton 1994; Somlev and Tishkov 1994; Widdel 1988; Fig. 12.15). In addition to sewers, concrete corrosion problems today involve highway bridges, historic buildings and monuments (Eckhardt 1978; Islam et al. 1995; Jain et al. 1993; May et al. 1993), river dams (Mittelman and Danko 1995), and nuclear depositories (Pedersen 1996; Stroes-Gascoyne et al. 1996) where corrosion rates are unacceptably high.

Microorganisms Responsible for Deterioration

Recent findings suggest that microorganisms participate actively in the degradation of buildings by utilization of pollutants deposited from the atmosphere as primary substrates (Corvo et al. 1997; Hutchinson et al. 1993; Lefebvre-Drouet and Rousseau 1995; Mitchell and Gu 2000; Ortega-Calvo et al. 1991; Saiz-Jimenez 1995; Warcheid et al. 1991; Fig. 12.16). The predominant groups of microorganisms are those capable of sulfur oxidation (Kulpa and Baker 1990; Sand 1987) and nitrification (Bock et al. 1986; Hirsch et al. 1995a, b; Jazsa et al. 1996a; Sand et al. 1983, 1987, 1991). Reported microorganisms associated with biodeterioration of building stone include *Thiobacillus*, *Desulfovibrio*, *Nitrosomonas*, *Nitrosococcus*, *Nitrobacter*, *Bacillus*, *Pseudomonas*, *Micrococcus*, and *Staphylococcus*. Actinomyces include *Nocardia*, *Micropolyspora*, *Micromonospora*, *Microbispora*, and *Streptomyces*. Cyanobacteria include *Anabaena*, *Anacystis*, *Aphanothece*, *Aulosira*,

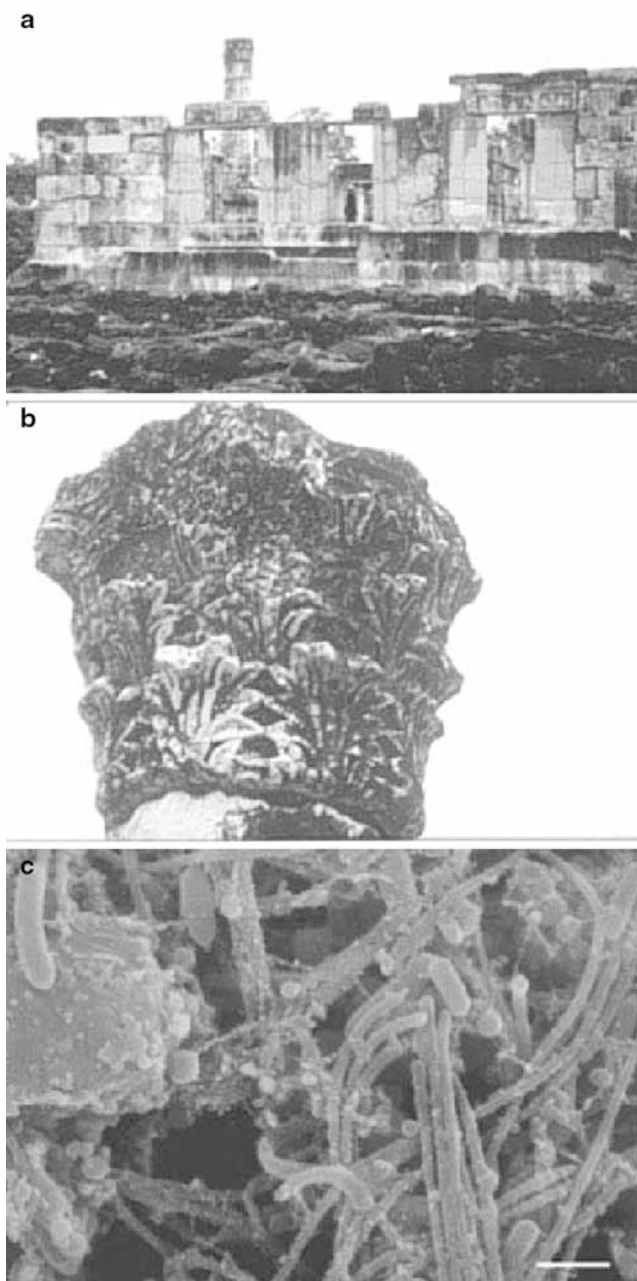

■ **Fig. 12.16**
Deterioration of an ancient building by microorganisms. (a) A view of the building, (b) a close-up of a black layer of microorganisms on the stone, and (c) a scanning electron micrograph illustrating the dense complex microbial community (bar = 1 μm)

Calothrix, *Chlorogloea*, *Chroococcus*, *Entophysalis*, *Gloeocapsa*, *Gomphosphaeria*, *Heterohormogonium*, *Lyngbya*, *Microcystis*, *Nostoc*, *Oscillatoria*, *Phormidium*, *Porphyrosiphon*, *Schizothrix*, *Scytonema*, *Stignoema*, *Synechocystis*, and *Tolypothrix*. Organic acids, particularly from fungi, were also found to contribute to building and concrete corrosion (Gu et al. 1996a). Bacterial exopolysaccharides may also be involved in degradation of building materials (Ford et al. 1986, 1987a, 1995; Gu et al. 1998b).

Chemical and biological processes interact, resulting in the corrosion of the materials (Chen et al. 1995, 1996). However, a systematic approach that integrates the role of both acid deposition and microbial activity with degradation of concrete and stone has not been attempted. Data describing stone degradation in the presence of various natural microbial populations have been made available in recent years (Flores et al. 1997; Hirsch et al. 1995b; Krumbein 1968; Tayler and May 1991, 1994; Tiano et al. 1995; Torre et al. 1991, 1993a, b). Pollutants in the air may become a source of microbial substrates on building materials and monuments (Mitchell and Gu 2000), in the form of not only sulfurous and nitrogenous oxides but also hydrocarbons and other sulfur- and nitrogen-containing compounds (Gómez-Alarcón et al. 1995a, b; Jorgensen 1988; Jazsa et al. 1996a; Kelley 1981; Kelley et al. 1987; MacDonald 1986; Ortega-Morales et al. 1999; Saiz-Jimenez 1995; Schmidt 1982). Information regarding the interaction of the natural microflora with these chemicals on concrete surfaces is still very limited.

Bock and Sand (1990) found that the nitrifying bacteria play an important role in the degradation of concrete as a result of nitric acid production during nitrification (Jazsa et al. 1996a). Nitrifying bacteria were also found to be the predominant contributors to the deterioration of other stone materials (Ehrich and Bock 1996; Gómez-Alarcón et al. 1995a, b). These bacteria differ from the thiobacilli in that the former are capable of growth on nonimmersed surfaces (such as buildings), whereas the latter require an aqueous environment in the presence of sulfate.

Microbial Exopolymers

Microorganisms produce large quantities of exopolymeric materials in late growth phase and/or in high carbon/nitrogen (C/N) ratio environments or during adhesion to surfaces. These polymeric materials are important carbon and energy reserves and are utilized during periods of nutrient deficiency. Bacterial exopolymeric materials also play an important role in the formation of microbial biofilms (Bonet et al. 1993; Davies et al. 1998), subsequent corrosion of metals, and transport of metal ions in porous media (Chen et al. 1995, c; Ford and Mitchell 1992; Ford et al. 1986, 1987a, 1995). They are multifunctional group molecules (Ford et al. 1991; Paradies 1995). The activity of these molecules and their functional groups in chelation and dissolution of calcium from concrete is still not understood. Ford and Mitchell (1992) and Geesey et al. (1986) proposed that bacterial exopolymers bind metals and promote formation of ionic concentration cells, accelerating dissolution and corrosion of metallic materials. Similarly, negatively charged carboxylic and hydroxyl groups of exopolymeric materials from thiobacilli (► Fig. 12.17) may form complexes with calcium and leach the calcium from concrete matrices. This process may contribute to concrete degradation, particularly when biofilms grow in close proximity to the surface (► Fig. 12.18). Further research is needed to identify a possible role for these exopolymers in concrete degradation.

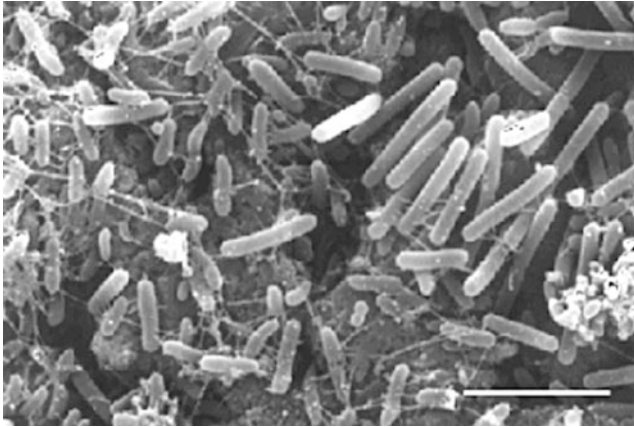

■ Fig. 12.17
Scanning electron micrograph of *Thiobacillus ferrooxidans* on the surface of corroding concrete (bar = 5 μm)

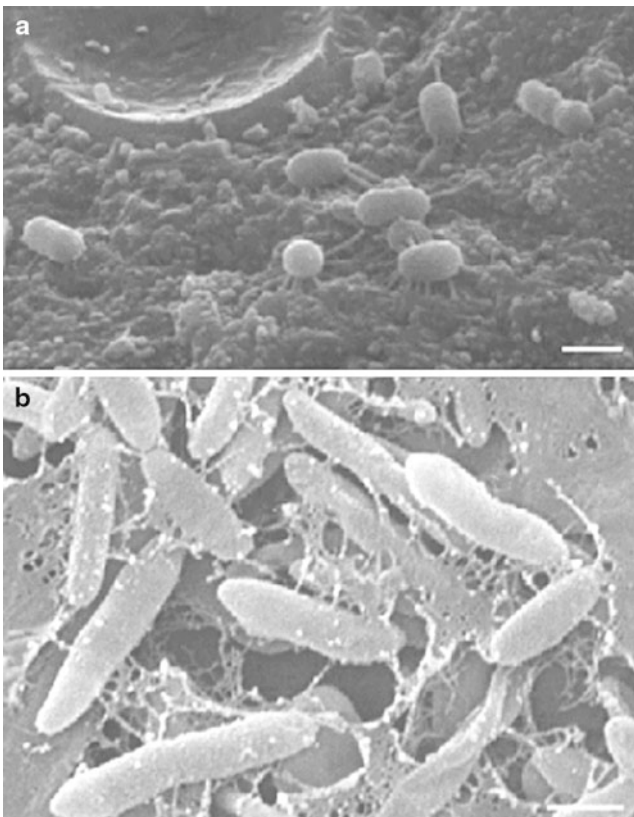

■ Fig. 12.18
Scanning electron micrographs of (a) a bacterial attachment on a concrete surface (bar = 1 μm) and (b) bacteria and their exopolymers (bar = 5 μm)

Corrosion of Reinforcing Materials

Concrete is often formulated with steel reinforcement for a wide range of applications. Reinforcement of concrete with steel bars may accelerate concrete corrosion because of the growth of SRBs

and the resultant production of H_2S in submerged environments. Both SRBs and the H_2S are detrimental to steel (Gu et al. 2000a). The corrosion products expand in volume, generating stress for surrounding concrete materials and resulting in cracks in the concrete (Broomfield 2000; Millard et al. 1995; Nakagawa et al. 1993; Saito et al. 1995). In this case, biological and physicochemical processes act in concert. Preventive measures involve the use of polymeric coating or reinforced polymeric sheets to prevent moisture reaching the steel reinforcing bars. Microbial activity is significantly reduced at low moisture levels (Gu et al. 1998c).

Hydrogen-producing bacteria may also contribute to the stress cracking of high-strength steel. Ford and Mitchell (1990b) reported the presence of bacteria in the cracking areas of a high-strength steel bar under loading conditions. They suggest that metabolites of these bacteria, particularly molecular hydrogen, would significantly weaken the strength of steel, owing to permeation of the alloy with microbially produced hydrogen (Ford et al. 1990b).

Biodeterioration of Cultural Heritage Materials

Additional materials of interest and importance to society for protection from biodeterioration are objects with historical and cultural value. Examples of these materials are bronze (Wang et al. 1991, 1993, Wu et al. 1992; Zuo et al. 1994), jade, ceramic and glass (Fuchs et al. 1991), lacquer, silk, papers (Adamo et al. 1998; Arai 2000; Fabbri et al. 1997; Florian 1996; Zyska 1996), paintings (Fabbri et al. 1997; Lauwers and Heinen 1974; Rölleke et al. 1998), animal bones and shells, wood (Blanchette 1995; King and Eggins 1972), and mummified bodies. Figure 12.19 shows ancient script on paper, a textile and a bronze object, and a modern book from a library in the tropics. These materials suffer from potential biodeterioration due to the growth of microorganisms. Preservation of a variety of historic cultural materials presents a major challenge, especially where microbial activities are involved.

Wood is susceptible to a wide range of biodeteriogens including rodents, insects, and microorganisms (Blanchette 1995). Common treatment involves deep freezing and biocides. Maintenance of low humidity and low temperature are important factors in the inhibition of microbial deterioration.

Staining of historic paper manuscripts, known as “foxing,” appears to have a microbial origin. Though several mechanisms of foxing found in museums and libraries (Fabbri et al. 1997; Florian 1996) have been proposed, the cause is still not understood. In one proposed mechanism, fungal spores are believed to contribute to the development of color, and melanin synthesis may be involved (Williamson et al. 1998). Treatment using biocides is widely debated on the basis of their effectiveness, potential adverse effects on the materials, and the environmental impact of the chemicals (Hugo 1995).

Leather and mummified materials are polymers that were dehydrated for long-term preservation. When they are being

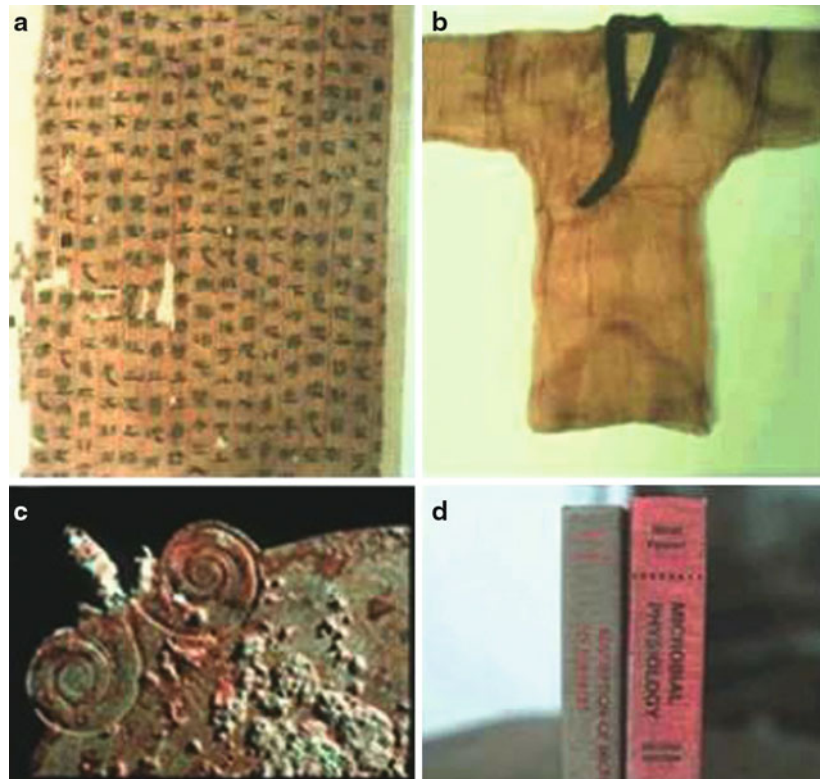

■ Fig. 12.19

Photographs showing (a) an ancient script, (b) textile, (c) bronze, and (d) a moldy book from a library in the tropics

kept under low humidity and sealed conditions, long-term preservation is feasible. However, deterioration may be due to oxidation by atmospheric oxygen and adsorption of moisture. When the moisture level is increased, further growth of microorganisms occurs. One example is the deterioration of recovered mummies after their archaeological excavation.

Organic polymers are widely used in consolidation of monuments (Selwitz 1992). Utilization of these materials by microorganisms has been documented (Gu and Mitchell, unpublished data), and guidelines are needed for systematic evaluation of candidate polymers and their suitability in specific applications. Polymer additives are also probable sources of carbon and energy for microbial growth (Gu et al. 1998c, 2000d; Tilstra and Johnsonbaugh 1993). Physical conditions for biodeterioration are favorable, particularly in tropical and subtropical developing countries.

The application of biocides has become a routine practice in the conservation of cultural heritage materials (► Fig. 12.20). However, environmental issues have severely limited the number of available effective biocidal chemicals for use in conservation (Bingaman and Willingham 1994).

Detection and Preventive Strategies

Microbial growth and propagation on material surfaces can be controlled by physical or chemical manipulation of the material or the environment. Prevention includes surface engineering to

prevent microbial adhesion (Mansfeld 1994; Matamala et al. 1994; Scamans et al. 1989; Williamson 1994; Young 1948). Methods of detection of growth on surfaces are well described in the literature (e.g., Madigan et al. 2000; Balow et al. 1992; Krieg and Holt 1984; Sneath et al. 1986; Staley et al. 1989; Williams et al. 1989). Humidity control is commonly used to inhibit growth of microorganisms on surfaces in enclosed environments (Gu et al. 1998c).

Control measures require information about the biofilm population. Molecular methods permit early detection of growth on surfaces (Amann et al. 1995). Using the principle of modification of the microbial community, Sand et al. (1991) proposed oxygenation as a means of alleviating the propagation of SRBs. Alternatively, biocides can be effective in controlling biofilms and subsequent deterioration of materials (Bell and Chadwick 1994; Bell et al. 1992; Wakefield 1997). Other attempts at community modification include precipitation of microbially produced H_2S by ferrous chloride (Morton et al. 1991) and displacement of *Thiobacillus* by heterotrophic bacteria (Padival et al. 1995). All of these efforts have met with limited success.

Biocides are commonly applied in repairing, cleaning, and maintenance of artworks. Chlorine and iodine compounds are used widely and routinely in controlling biofilms that cause corrosion of a wide range of industrial materials (Bloomfield and Megid 1994; Cargill et al. 1992; Chen and Stewart 1996). These chemicals have been shown to be ineffective as means of

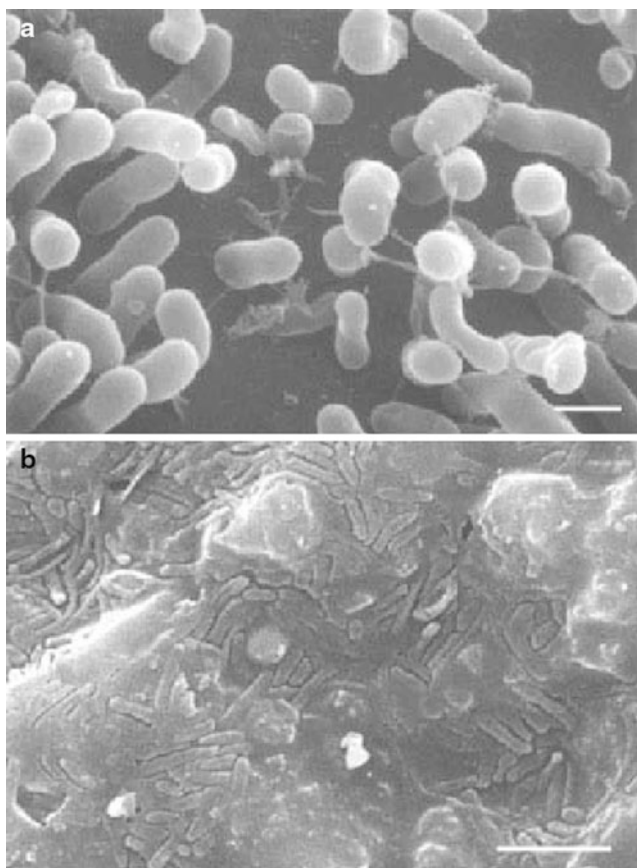

■ Fig. 12.20
Scanning electron micrographs showing (a) bacterial biofilm developed on the surface of a protective coating ($bar = 5 \mu m$) and (b) biofilm on the same coating, containing a biocide, but with the bacteria killed ($bar = 5 \mu m$)

killing biofilm bacteria (Huang et al. 1996; Keevil and Mackerness 1990; Koenig et al. 1995; Liu et al. 1998; Lü et al. 1984, 1989; McFeters 1991; McFeters et al. 1995; Moore and Postle 1994; Myers 1988; Pyle et al. 1992; Reinsel et al. 1996; Rossmoore and Rossmoore 1993; Srinivasan et al. 1995; Stewart 1996; Stewart et al. 1996; Suci et al. 1998; Wakefield 1997; Xu et al. 1996; Yu and McFeters 1994). In addition to their environmental unacceptability, biocides induce the development of biofilms that are highly resistant to the levels of biocide normally utilized to prevent biocorrosion. Organic biocides, used to prevent bacterial growth in industrial systems, may selectively enrich populations of microorganisms capable of biocide resistance (● Fig. 12.21). No solution to these problems is currently available. Alternative biocides have been screened from natural products (Abdel-Hafez and El-Said 1997; Bell and Chadwick 1994; Bell et al. 1992; Brözel and Cloete 1993). Current research by materials scientists is focused on the prevention of adhesion of corrosive microorganisms to surfaces through surface treatment and modification (Costerton et al. 1988).

Since bacteria are capable of forming biofilms on most surfaces, future tests should be focused on biofilm quantification. In assaying biocide efficacy, tests should be conducted based on biofilm populations rather than on liquid culture efficacy (Gu et al. 1998c, 2000c). Planktonic cells are not representative of conditions on surfaces of materials.

Unfortunately, routine analysis is not effective in the development of control strategies. Simulation testing of microbial growth on materials frequently includes only selected species of fungi (ASTM 1993a, b, c, d, e). In addition, biodeterioration assessment is rarely quantitative. Modern methods are available to determine biodeterioration kinetics (Gross et al. 1993, 1995,

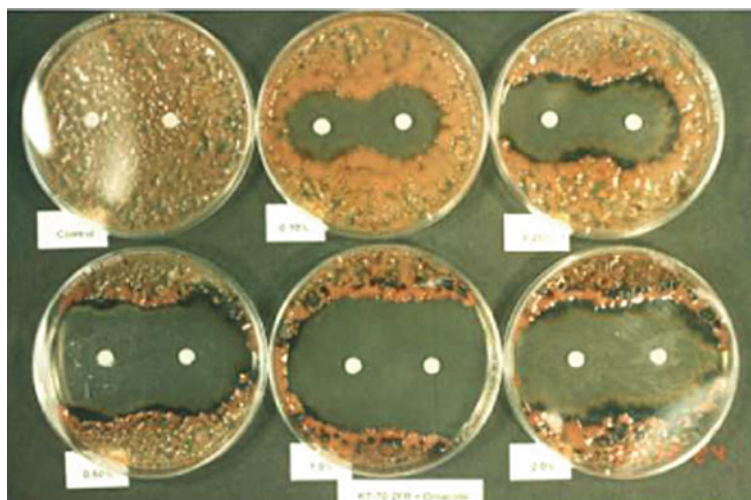

■ Fig. 12.21
At low concentrations of biocide, resistant bacteria are selected



■ Fig. 12.22
Microbial adhesion and consequent deterioration only occurred at the top (dark) part of the building. The lower protected portion was free of bacteria and deterioration

Gu et al. 2000a). Recently, a sensitive method was introduced to evaluate polymer integrity using electrochemical impedance spectroscopy (Gu et al. 1998b).

Surface engineering also provides a means of preventing adhesion of microorganisms and subsequent material deterioration (Mansfeld 1994; Matamala et al. 1994; Scamans et al. 1989; Williamson 1994; Young 1948; ● Fig. 12.22). Protection can be enhanced by early detection (Li et al. 1997). New detection technologies include optical fibers (Bacci 1995). DNA probes and microarrays (Raychaudhuri et al. 2001; Salama et al. 2000) are being increasingly utilized to control biodeterioration of materials.

Conclusions

Microorganisms are involved in the corrosion of metal and the degradation and deterioration of polymers, concrete, and stone under both aerobic and anaerobic conditions. They may influence the surface electrochemical properties, resulting in corrosion of metals under aerobic conditions, and induce hydrogen embrittlement by microbial production of hydrogen. Indirectly, degradation and deterioration of metals, stone, and concrete are

often associated with complexation mechanisms of microbial exopolysaccharides with substratum materials. We have only recently begun to understand the complex nature of interactions between the microflora and metals leading to corrosion. Modern methods in molecular biology, specifically gene technology, combined with recently developed techniques in materials science, such as laser confocal scanning microscopy and atomic force microscopy, should permit us to understand more fully the role of microorganisms in metal corrosion.

Protection of materials can be achieved to some extent through surface engineering and control of the physical, chemical, and biological environments. Application of biocides presents major challenges. A better understanding of the microbial ecology on material surfaces will be needed before a suitable control strategy can be identified. Utilization of molecular techniques to detect specific groups of microorganisms involved in the degradation process will permit a more complete view of the organization of the microbial community involved in the attack of materials. Passivation mechanisms of metals by bacteria should be further elucidated. Control methods should be developed based on combined information about both the material characteristics and the microbial community.

Acknowledgments

Preparation of this manuscript was partially supported by the “One-Hundred Talent Project” of the Chinese Academy of Sciences to J.-D.G. This work was also supported in part by grants No. BES-990 6337 from the U.S. Natural Parks Service, National Center for the Preservation Technology and Training to Harvard University. We would like to thank Jessie Lai and Yanzhen Fan for the digitalization of images and Yanzhen Fan for preparation of the references.

References

- Abdel-Hafez SII, El-Said AHM (1997) Effect of garlic, onion and sodium benzoate on the mycoflora of pepper, cinnamon and rosemary in Egypt. *Int Biodeter Biodegr* 39:67–97
- Adamo AM, Giovannotti M, Magaudda G, Plossi Zappalà M, Rocchetti F, Rossi G (1998) Effect of gamma rays on pure cellulose paper. *Restaurator* 19:41–59
- Albertsson A-C (1980) The shape of the biodegradation curve for low and high density polyethylenes in prolonged series of experiments. *Eur Polym J* 16:623–630
- Albertsson A-C, Andersson SO, Karlsson S (1987) The mechanism of biodegradation of polyethylene. *Polym Degr Stab* 18:73–87
- Albertsson A-C, Barenstedt C, Karlsson S (1994) Abiotic degradation products from enhanced environmentally degradable polyethylene. *Acta Polym* 45:97–103
- Alexander M (1977) Ecological interrelationships. In: Alexander M (ed) *Introduction to soil microbiology*, 2nd edn. Wiley, New York, pp 405–456
- Amann RI, Ludwig W, Schleifer K-H (1995) Phylogenetic identification and in situ detection of individual microbial cells without cultivation. *Microbiol Rev* 59:143–169
- Anderson AJ, Dowes EA (1990) Occurrence, metabolism, metabolic role, and industrial uses of bacterial polyhydroxyalkanoates. *Microbiol Rev* 54:450–472

- Andrady AL, Pegram JE, Nakatsuka S (1993) Studies on enhanced degradable plastics. 1: the geographic variability in outdoor lifetimes of enhanced photodegradable polyethelenes. *J Environ Polym Degr* 1:31–43
- Angell P, Luo JS, White DC (1995) Studies of the reproducible pitting of 304 stainless steel by a consortium containing sulphate-reducing bacteria. In: Agell P, Borenstein SW, Buchanan RA, Dexter SC, Dowling NJE, Little BJ, Lundin CD, McNeil MB, Pope DH, Tatnall RE, White DC, Ziegenfuss HG (eds) International conference on microbial induced corrosion NACE international. Houston TX 1/1–10
- Angles ML, Marshall KC, Goodman AE (1993) Plasmid transfer between marine bacteria in the aqueous phase and biofilms in reactor microcosms. *Appl Environ Microbiol* 59:843–850
- Appanna VD, Piperre MS (1996) Aluminum elicits exocellular phosphatidylethanolamine production in *Pseudomonas fluorescens*. *Appl Environ Microbiol* 62:2778–2782
- Arai H (2000) Foxing caused by fungi: twenty-five years of study. *Int Biodeter Biodegr* 46:181–188
- Arino X, Hernandez-Marine M, Saiz-Jimenez C (1997) Colonization of Roman tombs by calcifying cyanobacteria. *Phycologia* 36:366–373
- Ascaso C, Wierzychos J, Castello R (1998) Study of the biogenic weathering of calcareous litharenite stones caused by lichen and endolithic microorganisms. *Int Biodeter Biodegr* 42:29–38
- ASTM (American Society for Testing, and Materials) (1993a) Standard practice for determining resistance of synthetic polymeric materials to fungi 1993 Annual Book of ASTM Standards. ASTM, Philadelphia PA 08.03, G21-90 527–529
- ASTM (American Society for Testing, and Materials) (1993b) Standard practice for determining resistance of plastics to bacteria 1993 Annual Book of ASTM Standards. ASTM, Philadelphia, PA, 08.03, G22-76 531–533
- ASTM (American Society for Testing, and Materials) (1993c) Standard test method for determining the aerobic biodegradability of degradable plastics by specific microorganisms 1993 Annual Book of ASTM Standards. ASTM, Philadelphia, PA 08.03, D5247-92 401–404
- ASTM (American Society for Testing, and Materials) (1993d) Standard test method for assessing the aerobic biodegradation of plastic materials in an activated-sludge-wastewater-treatment system 1993 Annual Book of ASTM Standards ASTM, Philadelphia, PA 08.03, D5247-92 411–416
- ASTM (American Society for Testing, and Materials) (1993e) Standard test method for determining aerobic biodegradation of plastic materials under controlled composting conditions 1993 Annual Book of ASTM Standards. ASTM, Philadelphia, PA 08.03, D5338-92 444–449
- Atlas RM, Bartha R (1997) Physiological ecology of microorganisms: adaptations to environmental conditions. In: Atlas RM, Bartha R (eds) *Microbial ecology: fundamentals and applications*, 4th edn. Benjamin/Cummings, Menlo Park, pp 281–331
- Audouard JP, Compère C, Dowling NJE, Feron D, Festy D, Mollica A, Rogne T, Scotto V, Steinsmo U, Taxen K, Thierry D (1995) Effect of marine biofilms on high performance stainless steel exposed in European coastal waters. In: *Microbial corrosion: proceedings of the 3rd international european federation of corrosion (EFC) Workshop European Federation of Corrosion EFC Publication no. 15*, pp 198–210
- Bacci M (1995) Fibre optics applications to works of art. *Sensors Actuat B29:190–196*
- Balow A, Trüper HG, Dworkin M, Harder W, Schleifer KH (1992) The prokaryotes I, II, III, and IV. Springer, New York, <http://www.prokaryotes.com>
- Barlaz MA, Ham RK, Schaefer DM (1989a) Mass-balance analysis of anaerobically decomposed refuse. *J Environ Eng* 115:1088–1102
- Barlaz MA, Schaefer DM, Ham RK (1989b) Bacterial population development and chemical characterization of refuse decomposition in a simulated sanitary landfill. *Appl Environ Microbiol* 55:55–65
- Bazylinski DA, Garrett-Reed AJ, Abedi A, Frankel RB (1993) Copper association with iron sulfide magnetosomes in a magnetotactic bacterium. *Arch Microbiol* 160:35–42
- Becker TW, Feumbein WE, Warscheid T, Resende MA (1994) Investigation into microbiology. In: Herkenrath GM (ed) *Investigations into devices against environmental attack on stone*. GKSS-Forschungszentrum/GmbH, Geesthacht, pp 147–190
- Bell E, Dowling P, Cooper TP (1992) The effect of a biocide treatment and a silicone treatment on the weathering of limestone. *Environ Technol* 13:687–693
- Bell GM, Chadwick J (1994) Regulatory controls on biocides in the United Kingdom and restrictions on the use of triorganotin-containing antifouling products. *Int Biodeter Biodegr* 34:375–386
- Berekaa MM, Lino A, Reichelt R, Keller U, Steinbüchel A (2000) Effect of pretreatment of rubber material on its biodegradability by various rubber degrading bacteria. *FEMS Microbiol Lett* 184:199–206
- Béranger J-F, Frixon C, Bigliardi J, Creuzet N (1985) Production, purification and properties of thermostable xylanase from *Clostridium stercoararium*. *Can J Microbiol* 31:635–643
- Beveridge TJ, Makin SA, Kadurugamuwa JL, Li Z (1997) Interactions between biofilms and the environment. *FEMS Microbiol Rev* 20:291–303
- Bianchi A, Favali MA, Barbieri N, Bassi M (1980) The use of fungicides on mold-covered frescoes in S. Eusebio in Pavia. *Int Biodeter Bull* 16:45–51
- Biczok I (1968) Betonkorrosion. Betoschutz, Wiesbaden/Berlin, pp 28–30
- Bingaman WW, Willingham GL (1994) The changing regulatory environment: EPA registration of a new marine antifoulant active ingredient. *Int Biodeter Biodegr* 34:387–399
- Bitton G (1980) Adsorption of viruses to surfaces: technological and ecological implications. In: Bitton G, Marshall KC (eds) *Adsorption of microorganisms to surfaces*. Wiley, New York, pp 331–374
- Bitton G (1994) Processes based on attached microbial growth. In: Bitton G (ed) *Wastewater microbiology*. Wiley, New York, pp 189–198
- Blake RC II, Norton WN, Howard GT (1998) Adherence and growth of a *Bacillus* species on an insoluble polyester polyurethane. *Int Biodeter Biodegr* 42:63–73
- Blakemore RP (1982) Magnetotactic bacteria. *Ann Rev Microbiol* 36:217–238
- Blanchette RA (1995) Biodeterioration of archaeological wood. *Biodeter Abstr* 9:113–127
- Bloomfield SF, Megid R (1994) Interaction of iodine with *Bacillus subtilis* spores and spore forms. *J Appl Bacteriol* 76:492–499
- Bock E, Koops HP, Harms H (1986) Cell biology of nitrifying bacteria. In: Prosser JI (ed) *Nitrification*. IRL Press, Oxford, UK, pp 17–38
- Bock E, Ahlers B, Myer C (1989) Biogene Korrosion von Beton- und Natursteinen durch salpetersäure bildende Bakterien Bauphysik 11:141–144
- Bock E, Sand V (1990) Microbially influenced corrosion of concrete and natural sandstone. In: Dowling NJ, Mittelman MW, Danko JC (eds) *Microbially influenced corrosion and biodeterioration*. National Association of Corrosion Engineers, Houston, pp 3/29–3/33
- Bogan RT, Brewer RT (1985) Cellulose esters, organic. In: Kroschwitz JI (ed) *Encyclopedia of polymer science and engineering*, 2nd edn. Wiley, New York, pp 158–181
- Bonet R, Simon-Pujol MD, Congregado F (1993) Effects of nutrients on exopolysaccharide production and surface properties of *Aeromonas salmonicida*. *Appl Environ Microbiol* 59:2437–2441
- Booth GH, Tiller AK (1960) Polarization studies of mild steel in cultures of sulphate-reducing bacteria. *Trans Faraday Soc* 56:1689–1696
- Booth GH, Tiller AK (1962) Polarization studies of mild steel in cultures of sulphate-reducing bacteria. Part 2: thermophilic organisms. *Trans Faraday Soc* 58:110–115
- Booth GH, Tiller AK, Wormwell F (1962) Ancient iron nails well preserved from apparently corrosive soils. *Nature (Lond)* 195:376–377
- Booth GH, Elford L, Wakerly DJ (1968) Corrosion of mild steel by sulfate-reducing bacteria: an alternative mechanism. *Br Corrosion J* 3:242–245
- Borenstein S (1994) *Microbiologically influenced corrosion handbook*. Woodhead, Cambridge, MA, p 56
- Bos R, van der Mei HC, Busscher HJ (1999) Physico-chemistry of initial microbial adhesion interactions – its mechanisms and methods for study. *FEMS Microbiol Rev* 23:179–230
- Bouwer EJ (1992) Bioremediation of organic contaminants in the subsurface. In: Mitchell R (ed) *Environmental microbiology*. Wiley, New York, pp 319–333
- Brandl H, Gross RA, Lenz RW, Fuller RC (1988) *Pseudomonas oleovorans* as a source of poly(β -hydroxyalkanoates) for potential application as biodegradable polyesters. *Appl Environ Microbiol* 54:1977–1982
- Breslin VT (1993) Degradation of starch-plastic composites in a municipal solid waste landfill. *J Environ Polym Degr* 1:127–141

- Breslin VT, Swanson RL (1993) Deterioration of starch-plastic composite in the environment. *J Air Waste Manag Assoc* 43:325–335
- Breslin CB, Chen C, Mansfeld F (1997) The electrochemical behaviour of stainless steels following surface modification in cerium-containing solutions. *Corrosion Sci* 39:1061–1073
- Breznak JA (1984) Activity on surfaces. In: Marshall KC (ed) *Microbial adhesion and aggregation*. Dahlem Konferenzen/Springer, Berlin, pp 203–221
- Broomfield JP (2000) Corrosion of steel in concrete. In: Revie RW (ed) *Uhligh's corrosion handbook*, 2nd edn. Wiley, New York, pp 581–600
- Brown GA (1982) Implications of electronic and ionic conductivities of polyimide films in integrated circuit fabrication. In: Feit ED, Wilkins CW (eds) *Polymer materials for electronic applications*. American Chemical Society, Washington DC, ACS Symposium Ser, vol 184, pp 151–169
- Brözel VS, Cloete TE (1993) Bacterial resistance to conventional water treatment biocides. *Biodeter Abstr* 7:387–395
- Brune A, Frenzel P, Cypionka H (2000) Life at the oxic-anoxic interface: microbial activities and adaptations. *FEMS Microbiol Rev* 24:691–710
- Bryers JD (1990) Biofilms in biotechnology. In: Characklis WG, Marshall KC (eds) *Biofilms*. Wiley, New York, pp 733–773
- Bryers JD, Characklis WG (1990) Biofilms in water and wastewater treatment. In: Characklis WG, Marshall KC (eds) *Biofilms*. Wiley, New York, pp 671–696
- Bryers JD (1994) Biofilms and the technological implications of microbial cell adhesion. *Colloid Surf B Biointerf* 2:9–23
- Buchanan CM, Gardner RM, Komarek RJ (1993) Aerobic biodegradation of cellulose acetate. *J Appl Polym Sci* 47:1709–1719
- Budwill K, Fedorak PM, Page WJ (1992) Methanogenic degradation of poly(3-hydroxyalkanoates). *Appl Environ Microbiol* 58:1398–1401
- Busscher HJ, Sjollem J, van der Mei HC (1990) Relative importance of surface free energy as a measure of hydrophobicity in bacterial adhesion to solid surfaces. In: Doyle RJ, Rosenberg M (eds) *Microbial cell surface hydrophobicity*. American Society for Microbiology, Washington DC, pp 335–339
- Byrom D (1991) Miscellaneous biomaterials. In: Byrom D (ed) *Biomaterials: novel materials from biological sources*. Macmillan, New York, pp 335–359
- Cacciari I, Quatrini P, Zirletta G, Mincione E, Vinciguerra V, Lupattelli P, Sermanni GG (1993) Isotactic polypropylene biodegradation by a microbial community: physicochemical characterization of metabolites produced. *Appl Environ Microbiol* 59:3695–3700
- Caldwell DE, Lawrence JR (1986) Growth kinetics of *Pseudomonas fluorescens* microcolonies within the hydrodynamic boundary layers of surface micro-environments. *Microb Ecol* 12:299–312
- Caldwell DE, Wolfaardt GM, Korber DR, Lawrence JR (1997) Do bacterial communities transcend Darwinism? *Adv Microb Ecol* 15:105–191
- Callow ME, Fletcher RL (1994) The influence of low surface energy materials on bioadhesion – a review. *Int Biodeter Biodegr* 34:333–348
- Campaignolle X, Crolet J-L (1997) Method for studying stabilization of localized corrosion on carbon steel by sulfate-reducing bacteria. *Corrosion* 53:440–447
- Cargill KL, Pyle BH, McFeters GA (1992) Effects of culture conditions and biofilm formation on the iodine susceptibility of *Legionella pneumophila*. *Can J Microbiol* 38:423–429
- Cariola MG, Forni C, Albertano P (1987) Characterization of the algal flora growing on ancient Roman frescoes. *Phycologia* 26:387–397
- Chahal PS, Chahal DS, André G (1992) Cellulase production profile of *Trichoderma reesei* on different cellulosic substrates at various pH levels. *J Ferment Bioeng* 74:126–128
- Characklis WG (1990) Microbial fouling. In: Characklis WG, Marshall KC (eds) *Biofilms*. Wiley, New York, pp 523–584
- Chen G, Clayton CR, Sadowski RA, Gillow JB, Francis AJ (1995) Influence of sulfate-reducing bacteria on the passive film formed on austenitic stainless steel, AISI 304 NACE International, Houston TX Corrosion
- Chen G (1996) An XPS study of the passivity of stainless steels influenced by sulfate-reducing bacteria (PhD dissertation). State University of New York at Stony Brook, New York, p 279
- Chen X, Stewart PS (1996) Chlorine penetration into artificial biofilm is limited by a reaction-diffusion interaction. *Environ Sci Technol* 30:2078–2083
- Chen G, Kagwade SV, French GE, Ford TE, Mitchell R, Clayton CR (1996) Metal ion and expolymer interaction: a surface analytical study. *Corrosion* 52:891–899
- Choi MH, Yoon SC (1994) Polyester biosynthesis characteristics of *Pseudomonas citronellolis* grown on various carbon sources, including 3-methyl-branched substrates. *Appl Environ Microbiol* 60:3245–3254
- Clapp WP (1948) Macro-organisms in sea water and their effect on corrosion. In: Uhligh HH (ed) *The corrosion handbook*. Wiley, New York, pp 433–441
- Clark TR, Ehrlich HL (1992) Copper removal from an industrial waste by bioleaching. *J Ind Microbiol* 9:213–218
- Clayton CR, Halada GP, Kearns JR, Gillow JB, Francis AJ (1994) Spectroscopic study of sulfate reducing bacteria-metal ion interactions related to micro-biologically influenced corrosion (MIC). In: Kearns JR, Little BJ (eds) *Microbiologically influenced corrosion testing*. American Society for Testing and, Philadelphia, PA, ASTM STP, vol 1232, pp 141–152
- Corbett RA, Morrison WS, Bickford DF (1987) Corrosion evaluation of alloys for nuclear waste processing. *Mat Perf* 2:40–45
- Corvo F, Haces C, Betancourt N, Maldonado L, Véleca L, Echeverria M, de Rincón OT, Rincón A (1997) Atmospheric corrosivity in the Caribbean area. *Corrosion Sci* 39:823–833
- Costerton JW, Geesey GG, Cheng K-J (1978) How bacteria stick. *Scient Am* 238:86–95
- Costerton JW, Geesey GG, Jones PA (1988) Bacterial biofilms in relation to internal corrosion monitoring and biocide strategies. *Mat Perf* 4:49–53
- Costerton JW, Lewandowski Z, DeBeer D, Caldwell D, Korber D, James G (1994) Biofilms, the customized microniche. *J Bacteriol* 176:2137–2142
- Costerton JW, Lewandowski Z, Caldwell DE, Korber DR, Lappin-Scott HM (1995) Microbial biofilms. *Ann Rev Microbiol* 49:711–745
- Crabbe JR, Campbell JR, Thompson L, Walz SL, Scultz WW (1994) Biodegradation of a colloidal ester-based polyurethane by soil fungi. *Int Biodeter Biodegr* 33:103–113
- Cromwick A-M, Gross RA (1995) Investigation by NMR of metabolic routes to bacterial γ -poly(glutamic acid) using ^{13}C -labelled citrate and glutamate as media carbon source. *Can J Microbiol* 41:902–909
- Cunningham AB, Bouwer EJ, Characklis WG (1990) Biofilms in porous media. In: Characklis WG, Marshall KC (eds) *Biofilms*. Wiley, New York, pp 697–732
- Cunningham AM, Characklis WG, Abedeen F, Crawford D (1991) Influence of biofilm accumulation on porous media hydrodynamics. *Environ Sci Technol* 25:1305–1311
- Cunningham DP, Lundie LL Jr (1993) Precipitation of cadmium by *Clostridium thermoaceticum*. *Appl Environ Microbiol* 59:7–14
- Dalton HM, Poulsen LK, Halasz P, Angles ML, Goodman AE, Marshall KC (1994) Substratum-induced morphological changes in a marine bacterium and their relevance to biofilm structure. *J Bacteriol* 176:6900–6906
- Daniels L, Belay N, Rajagopal B, Weimer P (1987) Bacterial methanogenesis and growth from CO_2 with elemental iron as the sole source of electrons. *Science* 237:509–511
- Danin A (1993) Biogenic weathering of marble monuments in Didim, Turkey and in Trajan Column, Rome. *Water Sci Technol* 27:557–563
- Davey ME, O'Toole GA (2000) Microbial biofilms: from ecology to molecular genetics. *Microbiol Molec Biol Rev* 64:847–867
- Davidson D, Beheshti B, Mittelman MW (1996) Effects of *Arthrobacter* sp. *Acidovorax delafieldii*, and *Bacillus megaterium* colonisation on copper solvency in a laboratory reactor. *Biofouling* 9:279–292
- Davies DG, Parsek MR, Pearson JP, Iglewski BH, Costerton JW, Greenberg EP (1998) The involvement of cell-to-cell signals in the development of a bacterial biofilm. *Science* 280:295–298
- Devanathan MAV, Stachurski Z (1962) Adsorption and diffusion of electrolytic hydrogen in palladium. *Proc Roy Soc Lond A* 270:90–110
- Dexter SC (1993) Role of microfouling organisms in marine corrosion. *Biofouling* 7:97–127
- Dickinson WH, Caccavo F Jr, Lewandowski Z (1996) The ennoblement of stainless steel by manganic oxide biofouling. *Corrosion Sci* 38:1407–1422
- Dickinson WH, Caccavo F Jr, Olesen B, Lewandowski Z (1997) Ennoblement of stainless steel by the manganese-depositing bacterium *Leptothrix discophora*. *Appl Environ Microbiol* 63:2502–2506

- Diercks M, Sand W, Bock E (1991) Microbial corrosion of concrete. *Experientia* 47:514–516
- Dobbins JJ, Giammara BL, Hanker JS, Yates PE, DeVries WC (1989) Demonstration of the bacterial-biomaterial interface in implant specimens. In: Hanker JS, Giammara BL (eds) *Biomedical materials and devices materials*, vol 110. Research Society, Philadelphia, pp 337–348
- Doi Y (1990) Biodegradation of microbial polyesters. In: Doi Y (ed) *Microbial polyesters*. VCH, New York, pp 135–152
- Douglas S, Beveridge TJ (1998) Mineral formation by bacteria in natural microbial communities. *FEMS Microbiol Ecol* 26:79–88
- Dowling NJE, Brooks SA, Phelps TJ, White DC (1992) Effects of selection and fate of substrate supplied to anaerobic bacteria involved in the corrosion of pipeline steel. *J Ind Microbiol* 10:207–215
- Dowling NJE, Guezenc J (1997) Microbially influenced corrosion. In: Hurst CJ, Knudsen GR, McInerney MJ, Stetzenbach LD, Walter MV (eds) *Manual of environmental microbiology*. ASM Press, Washington, DC, pp 842–855
- Downing KM, Ho CS, Zabriskie DW (1987) Enzymatic production of ethanol from cellulose using soluble cellulose acetate as an intermediate. *Biotech Bioeng* 29:1086–1096
- Drake H (1994) Acetogenesis, acetogenic bacteria, and the acetyl-CoA 'Wood/Ljungdahl' pathway: past and current perspectives. In: Drake HL (ed) *Acetogenesis*. Chapman and Hall, New York, pp 1–60
- Dunn DS, Sridhar N, Cragolino GA (1995) Effects of surface chromium depletion on localized corrosion of alloy 825 as a high-level nuclear waste container material. *Corrosion* 51:618–624
- Dutton MV, Evans CS (1996) Oxalate production by fungi: its role in pathogenicity and ecology in the soil environment. *Can J Microbiol* 42:881–895
- Dwyer D, Tiedje JM (1983) Degradation of ethylene glycol and polyethylene glycols by methanogenic consortia. *Appl Environ Microbiol* 46:185–190
- Eashwar M, Marthamuthu S, Palanichamy S, Balakrishnan K (1995) Sunlight irradiation of seawater eliminates ennoblement-causation by biofilms. *Biofouling* 8:215–221
- Eckhardt FEW (1978) Microorganisms and weathering of a sandstone monument. In: Krumbein WE (ed) *Environmental biogeochemistry and geomicrobiology*, vol 2, The terrestrial environment. Ann Arbor Science, Ann Arbor, pp 675–586
- Edwards DP, Nevell TG, Plunkett BA, Ochiltree BC (1994) Resistance to marine fouling of elastomeric coatings of some poly(dimethylsiloxanes) and poly(dimethyldiphenylsiloxanes). *Int Biodeter Biodegr* 34:349–359
- Ehrlich S, Bock E (1996) Biogenic sulfuric acid corrosion test procedure for cement bound materials. In: Sand W (ed) *DECHEMA monographs*, vol 133, Biodeterioration and biodegradation. VCH Verlagsgesellschaft, Frankfurt, pp 193–198
- Ehrlich HL (1996) Geomicrobial processes: a physiological and biochemical overview. In: Ehrlich HL (ed) *Geomicrobiology*, 3rd edn. Marcel Dekker, New York, pp 108–142
- El-Sayed AHMM, Mohmoud WM, Davis EM, Coughlin RW (1996) Biodegradation of polyurethane coatings by hydrocarbon-degrading bacteria. *Int Biodeter Biodegr* 37:69–79
- Emerson A, Moyer C (1997) Isolation and characterization of novel iron-oxidizing bacteria that grow at circumneutral pH. *Appl Environ Microbiol* 63:4784–4792
- Enos DG, Taylor SR (1996) Influence of sulfate-reducing bacteria on alloy 625 and austenitic stainless steel weldments. *Corrosion* 52:831–842
- Evans UR (1948) An outline of corrosion mechanisms, including the electrochemical theory. In: Uhlig HH (ed) *The corrosion handbook*. Wiley, New York, pp 3–11
- Ezeonu IM, Noble JA, Simmons RB, Price DL, Crow SA, Ahearn DG (1994a) Effect of relative humidity on fungal colonization of fiberglass insulation. *Appl Environ Microbiol* 60:2149–2151
- Ezeonu IM, Price DL, Simmons RB, Crow SA, Ahearn DG (1994b) Fungal production of volatiles during growth on fiberglass. *Appl Environ Microbiol* 60:4172–4173
- Fabbri AA, Ricelli A, Brasini S, Fanelli C (1997) Effect of different antifungals on the control of paper biodeterioration caused by fungi. *Int Biodeter Biodegr* 39:61–65
- Feddema JJ, Mererding TC (1991) Marble deterioration in the urban atmosphere. In: Baer NS, Sabbioni C, Sors AI (eds) *Science, technology and European cultural heritage*. Butterworth-Heinemann, Oxford/England, pp 443–446
- Fenchel T, Finlay BJ (1995) Anaerobic environments. In: Fenchel T, Finlay BJ (eds) *Ecology and evolution in anoxic Worlds*. Oxford University Press, New York, pp 1–31
- Ferry JG (1995) Physiological ecology of methanogens. In: Ferry JG (ed) *Methanogenesis: ecology, physiology, biochemistry and genetics*. Chapman and Hall, New York, pp 128–206
- Filip Z (1978) Decomposition of polyurethane in a garbage landfill leakage water and by soil microorganisms. *Eur J Appl Microbiol* 5:225–231
- Fischer W, Haenßel I, Paradies HH (1987) Gutachten: Schadensanalyse von Korrosionshäden an Brauchwasserleitungen aus Kupferrohren im Krieskrankenhaus Lüdenscheid/Hellersen, FRG Märkischer Kreis 17 March
- Flemming H-C, Schaule G, McDonogh R, Ridgway HF (1994) Effects and extent of biofilm accumulation in membrane systems. In: Geesey GG, Lewandowski Z, Flemming HC (eds) *Biofouling and biocorrosion in industrial water systems*. Lewis, Boca Raton, pp 63–89
- Fletcher M, Loeb GI (1979) Influence of substratum characteristics on the attachment of a marine *Pseudomonad* to solid surfaces. *Appl Environ Microbiol* 37:67–72
- Fletcher M (1980) Adherence of marine micro-organisms to smooth surfaces. In: Beachey EH (ed) *Bacterial adherence*, vol 6, Receptors and recognition, Series B. Chapman and Hall, London, pp 345–374
- Fletcher M (1996) Bacterial attachment in aquatic environments: a diversity of surfaces and adhesion strategies. In: Fletcher M (ed) *Bacterial adhesion: molecular and ecological diversity*. Wiley-Liss, New York, pp 1–24
- Flores M, Lorenzo J, Gomez-Alarcon G (1997) Algae and bacteria on historic monuments at Alcalá de Henares, Spain. *Int Biodeter Biodegr* 40:241–246
- Florian M-LE (1996) The role of the conidia of fungi in fox spots. *Studies Conserv* 41:65–75
- Ford T, Black JP, Mitchell R (1986) Relationship between bacterial exopolymers and corroding metal surfaces. National Association of Corrosion Engineers, Houston
- Ford T, Maki J, Mitchell R (1987a) The role of metal-binding bacterial exopolymers in corrosion processes. National Association of Corrosion Engineers, Houston, pp 87–380
- Ford TE, Walch M, Mitchell R (1987b) Corrosion of metals by thermophilic microorganisms. *Mat Perf* 26:35–39
- Ford T, Maki J, Mitchell R (1988) Involvement of bacterial exopolymers in biodeterioration of metals. In: Houghton DR, Smith RN, Eggins HOW (eds) *Biodeterioration*, vol 7. Elsevier Science, New York, pp 378–384
- Ford T, Mitchell R (1990a) Metal brittleness by bacterial hydrogen – an overview. *Marine Technol Soc J* 24:29–35
- Ford T, Mitchell R (1990b) The ecology of microbial corrosion. In: Marshall KC (ed) *Advances in microbial ecology*, vol 11. Plenum Press, New York, pp 231–262
- Ford TE, Seaton PC, Harris T, Mitchell R (1990a) Investigation of microbiologically produced hydrogen permeation through palladium. *J Electrochem Soc* 137:1175–1179
- Ford TE, Black JP, Mitchell R (1990b) Relationship between bacterial exopolymers and corroding metal surfaces. NACE International, Houston, pp 90–110
- Ford T, Sacco E, Black J, Kelley T, Goodacre R, Berkley RCW, Mitchell R (1991) Characterization of exopolymers of aquatic bacteria by pyrolysis-mass spectroscopy. *Appl Environ Microbiol* 57:1595–1601
- Ford T, Mitchell R (1992) Microbial transport of toxic metals. In: Mitchell R (ed) *Environmental microbiology*. Wiley, New York, pp 83–101
- Ford TE (1993) The microbial ecology of water distribution and outfall systems. In: Ford TE (ed) *Aquatic microbiology: an ecological approach*. Blackwell Scientific, Boston, pp 455–482
- Ford T, Maki J, Mitchell R (1995) Metal-microbe interactions. In: Gaylarde CC, Videla HA (eds) *Bioextraction and biodeterioration of metals*. Cambridge University Press, New York, pp 1–23
- Fortin D, Southam G, Beveridge TJ (1994) Nickel sulfide, iron-nickel sulfide and iron sulfide precipitation by a newly isolated *Desulfotomaculum* species and its relation to nickel resistance. *FEMS Microbiol Ecol* 14:121–132

- Frazer AC (1994) O-methylation and other transformations of aromatic compounds by acetogenic bacteria. In: Drake HL (ed) *Acetogenesis*. Chapman and Hall, New York, pp 445–483
- Freeman C, Lock MA (1995) The biofilm polysaccharide matrix: a buffer against changing organic substrate supply? *Limnol Oceanogr* 40:273–278
- Frings J, Schramm E, Schink B (1992) Enzymes involved in anaerobic polyethylene glycol degradation by *Pelobacter venetianus* and *Bacteroides* Strain PG1. *Appl Environ Microbiol* 58:2164–2167
- Fuchs DR, Popall M, Römich H, Schmidt H (1991) Preservation of stained glass windows: new materials and techniques. In: Baer NS, Sabbioni C, Sors AI (eds) *Science, technology and european cultural heritage*. Butterworth-Heinemann, Oxford/England, pp 679–683
- Gamerith G, Groicher R, Zeilinger S, Herzog P, Kubicek CP (1992) Cellulase-poor xylanases produced by *Trichoderma reesei* RUT C-30 on hemicellulose substrates. *Appl Microbiol Biotechnol* 38:315–322
- Gangloff RP, Kelly RG (1994) Microbe-enhanced environmental fatigue crack propagation in HY130 steel. *Corrosion* 50:345–354
- Garcia de Miguel JM, Sanchez-Castillo L, Ortega-Calvo JJ, Gil JA, Saiz-Jimenez C (1995) Deterioration of building materials from the Great Jaguar Pyramid at Tikal. *Guatemala Build Environ* 30:591–598
- Gazenko OG, Grigoryev AI, Bugrov SA, Yegorov VV, Bogomolov VV, Kozlovskaya IB, Tarasov IK (1990) Review of the major results of medical research during the flight of the second prime crew of the Mir space station (in Russian) *Kosmicheskaya Biologiya i Aviakosmicheskaya Medistina* 23:3–11
- Gebers R, Hirsch P (1978) Isolation and investigation of *Pedomicrobium* spp., heavy metal-depositing bacteria from soil habitats. In: Krumbein WE (ed) *Environmental biogeochemistry and geomicrobiology: methods, metals and assessment*, vol 3. Ann Arbor Science, Ann Arbor, pp 911–922
- Geesey GG, Mittelman MW, Iwaoka T, Griffiths PR (1986) Role of bacterial copolymers in the deterioration of copper surfaces. *Mat Perf* 25:37–40
- Geesey GG, White DC (1990) Determination of bacterial growth and activity at solid-liquid interfaces. *Ann Rev Microbiol* 44:579–602
- Geesey GG, Gills RJ, Avci R, Daly D, Hamilton M, Shope P, Harkon G (1996) The influence of surface features on bacterial colonization and subsequent substratum chemical change of 316 L stainless steel. *Corrosion Sci* 38:73–95
- Gehrke T, Telegdi J, Thierry D, Sand W (1998) Importance of extracellular polymeric substances from *Thiobacillus ferrooxidans* for bioleaching. *Appl Environ Microbiol* 64:2743–2747
- Gelmi M, Apostoli P, Cabibbo E, Porru S, Alessio L, Turano A (1994) Resistance to cadmium salts and metal absorption by different microbial species. *Curr Microbiol* 29:335–341
- Ghassem H, Adibi N (1995) Bacterial corrosion of reformer heater tubes. *Mat Perf* 34:47–48
- Ghiorse WC, Hirsch P (1978) Iron and manganese deposition by budding bacteria. In: Krumbein WE (ed) *Environmental Biogeochemistry and geomicrobiology*, vol 3, Methods, metals and assessment. Ann Arbor Science, Ann Arbor, pp 897–909
- Ghiorse WC, Hirsch P (1979) An ultrastructural study of iron and manganese deposition associated with extracellular polymers of *Pedomicrobium*-like budding bacteria. *Arch Microbiol* 123:213–226
- Ghiorse WC (1989) Manganese and iron as physiological electron donors and acceptors in aerobic-anaerobic transition zones. In: Cohen Y, Rosenberg E (eds) *Microbial mats: physiological ecology of benthic microbial communities*. American Society for Microbiology, Washington, DC, pp 163–169
- Gibson DT, Subramanian V (1984) Microbial degradation of aromatic hydrocarbons. In: Gibson DT (ed) *Microbial degradation of organic compounds*. Marcel Dekker, New York, pp 181–252
- Gillatt J (1990) The biodeterioration of polymer emulsions and its prevention with biocides. *Int Biodeter* 26:205–216
- Gillis RJ, Gillis JR (1996) A comparative study of bacterial attachment to high-purity water system surfaces. *Ultrapure Water* 9:27–36
- Gilmore DF, Antoun S, Lenz RW, Goodwin S, Austin R, Fuller RC (1992) The fate of biodegradable plastics in municipal leaf compost. *J Indust Microbiol* 10:199–206
- Gilmore DF, Antoun S, Lenz RW, Fuller RC (1993) Degradation of poly(β -hydroxyalkanoates) and polyolefin blends in a municipal wastewater treatment facility. *J Environ Polym Degr* 1:269–274
- Glagolev AN (1984) Motility and taxis in prokaryotes. In: Skulachev VP (ed) *Soviet scientific reviews supplement series: physicochemical biology*. Harwood Academic, Zurich, pp 59–64
- Gómez-Alarcón G, Cilleros B, Flores M, Lorenzo J (1995a) Microbial communities and alteration processes in monuments at Alcalá de Henares, Spain. *Sci Total Environ* 167:231–239
- Gómez-Alarcón G, Muñoz M, Arino X, Ortega-Calvo JJ (1995b) Microbial communities in weathered sandstone: the case of Carrasosa del Campo church, Spain. *Sci Total Environ* 169:249–254
- Gottschalk G (1986) Regulation of bacterial metabolism. In: Gottschalk G (ed) *Bacterial metabolism*, 2nd edn. Springer, New York, pp 178–282
- Gross RA, Gu J-D, Eberiel D, Nelson M, McCarthy SP (1993) Cellulose acetate biodegradability in simulated aerobic composting and anaerobic bioreactors as well as by a bacterial isolate derived from compost. In: Kaplan D, Thomas E, Ching C (eds) *Fundamentals of biodegradable materials and packaging*. Technomic, Lancaster, pp 257–279
- Gross RA, Gu JD, Eberiel D, McCarthy SP (1995) Laboratory scale composting test methods to determine polymer degradability: model studies on cellulose acetate. In: Albertson A, Huang S (eds) *Degradable polymers, recycling and plastics waste management*. Marcel Dekker, New York, pp 21–36
- Gu J-D, Berry DF (1991) Degradation of substituted indoles by an indole-degrading methanogenic consortium. *Appl Environ Microbiol* 57:2622–2627
- Gu J-D, Berry DF (1992) Metabolism of 3-methylindole by a methanogenic consortium. *Appl Environ Microbiol* 58:2667–2669
- Gu J-D, Berry DF, Taraban RH, Martens DC, Walker HL Jr, Edmonds WJ (1992a) Biodegradability of atrazine, cyanazine, and dicamba in wetland soils. Virginia Water Resource Research Center, Blacksburg
- Gu J-D, Gada M, Kharas G, Eberiel D, McCarty SP, Gross RA (1992b) Degradability of cellulose acetate (1.7 and 2.5, d. s.) and poly(lactide) in simulated composting bioreactors. *Polym Mater Sci Eng* 67:351–352
- Gu J-D, McCarty SP, Smith GP, Eberiel D, Gross RA (1992c) Degradability of cellulose acetate (1.7, d.s.) and cellophane in anaerobic bioreactors. *Polym Mat Sci Eng* 67:230–231
- Gu J-D, Coulter S, Eberiel D, McCarthy SP, Gross RA (1993a) A respirometric method to measure mineralization of polymeric materials in a matured compost environment. *J Environ Polym Degr* 1:293–299
- Gu J-D, Eberiel DT, McCarthy SP, Gross RA (1993b) Cellulose acetate biodegradability upon exposure to simulated aerobic composting and anaerobic bioreactor environments. *J Environ Polym Degr* 1:143–153
- Gu J-D, Eberiel D, McCarthy SP, Gross RA (1993c) Degradation and mineralization of cellulose acetate in simulated thermophilic composting environment. *J Environ Polym Degr* 1:281–291
- Gu J-D, Ford TE, Thorp KEG, Mitchell R (1994a) Microbial degradation of polymeric materials. In: Naguy T (ed) *Proceedings of the tri-service conference on corrosion*, 21–23 June 1994, Orlando, Florida. US Government Printing House, Washington, DC, pp 291–302
- Gu J-D, Yang S, Welton R, Eberiel D, McCarthy SP, Gross RA (1994b) Effects of environmental parameters on the degradability of polymer films in laboratory-scale composting reactors. *J Environ Polym Degr* 2:129–135
- Gu J-D, Mitchell R (1995) Microbiological influenced corrosion of metal, degradation and deterioration of polymeric materials of space application (in English). *Chinese J Mat Res* 9(Suppl):473–489
- Gu J-D, Ford TE, Mitton B, Mitchell R (1995a) Microbial degradation of complex polymeric materials used as insulation in electronic packaging materials. National Association of Corrosion Engineers, Houston
- Gu J-D, Ford TE, Thorp KEG, Mitchell R (1995b) Effects of microorganisms on stability of fiber reinforced polymeric composites. In: Hui D (ed) *Second international conference on composites engineering*. University of New Orleans, 21–24 Aug 1995, pp 279–280
- Gu J-D, Ford TE, Thorp KEG, Mitchell R (1995c) Microbial biodeterioration of fiber reinforced composite materials. In: Angell P, Borenstein SW, Buchanan RA, Dexter SC, Dowling NJE, Little BJ, Lundin CD, McNeil MB, Pope DH, Tatnall RE, White DC, Zigenfuss HG (eds) *1995 international conference on microbial influenced corrosion*. NACE International, Houston TX 25/1–7
- Gu J-D, Ford TE, Thorp KEG, Mitchell R (1995d) Microbial deterioration of fiber reinforced polymeric materials. In: Scully J (ed) *Corrosion/95, Research in progress symposium*. NACE International, Houston, pp 16–17

- Gu J-D, Ford TE, Berke NS, Mitchell R (1996a) Fungal degradation of concrete. In: Sand W (ed) DECHEMA monographs, Biodeterioration and biodegradation, vol 133. VCH, Frankfurt, pp 135–142
- Gu J-D, Ford TE, Mitchell R (1996b) Susceptibility of electronic insulating polyimides to microbial degradation. *J Appl Polym Sci* 62:1029–1034
- Gu J-D, Ford T, Thorp K, Mitchell R (1996c) Microbial growth on fiber reinforced composite materials. *Int Biodeter Degr* 39:197–204
- Gu J-D, Lu C, Thorp K, Crasto A, Mitchell R (1996d) Susceptibility of polymeric coatings to microbial degradation. NACE International, Houston
- Gu J-D, Thorp K, Crasto A, Mitchell R (1996e) Microbiological degradation of fiber-reinforced polymeric composites. In: The electrochemical society spring meeting, 5–10 May 1996, Los Angeles The Electrochemical Society, Pennington, pp 143–144
- Gu J-D, Lu C, Thorp K, Crasto A, Mitchell R (1997a) Fiber-reinforced polymeric composite materials are susceptible to microbial degradation. *J Ind Microbiol Biotechnol* 18:364–369
- Gu J-D, Lu C, Thorp K, Crasto A, Mitchell R (1997b) Fungal degradation of fiber-reinforced composite materials. *Mat Perf* 36:37–42
- Gu J-D, Maki JS, Mitchell R (1997c) Microbial biofilms and their role in the induction and inhibition of invertebrate settlement. In: D'Itri FM (ed) Zebra mussels and aquatic nuisance species. Ann Arbor Press, Chelsea, pp 343–357
- Gu J-D, Ford TE, Berke NS, Mitchell R (1998a) Biodeterioration of concrete by the fungus *Fusarium*. *Int Biodeter Biodegr* 41:101–109
- Gu J-D, Mitton DB, Ford TE, Mitchell R (1998b) Microbial degradation of polymeric coatings measured by electrochemical impedance spectroscopy. *Biodegradation* 9:35–39
- Gu J-D, Roman M, Esselman T, Mitchell R (1998c) The role of microbial biofilms in deterioration of space station candidate materials. *Int Biodeter Biodegr* 41:25–33
- Gu J-D, Ford TE, Mitchell R (2000a) Microbial corrosion of metals. In: Revie W (ed) The H. H. Uhlig corrosion handbook, 2nd edn. Wiley, New York, pp 915–927
- Gu J-D, Ford TE, Mitchell R (2000b) Microbial corrosion of concrete. In: Revie W (ed) The H. H. Uhlig corrosion handbook, 2nd edn. Wiley, New York, pp 477–491
- Gu J-D, Ford TE, Mitchell R (2000c) Microbial degradation of materials: general processes. In: Revie W (ed) The H. H. Uhlig corrosion handbook, 2nd edn. Wiley, New York, pp 349–365
- Gu J-D, Ford TE, Mitton DB, Mitchell R (2000d) Microbial degradation and deterioration of polymeric materials. In: Revie W (ed) The H. H. Uhlig corrosion handbook, 2nd edn. Wiley, New York, pp 439–460
- Gu J-D, Gu J-G, Li XY (2000e) Degradation of poly(hydroxybutyrate-co-16 % valerate) and cellulose acetate (DS 1.7 and 2.5) under simulated landfill condition. In: Bao X, Englande AJ (eds) Critical technologies to the World in 21st Century: pollution control and reclamation in process industries, September 18–20, 2000 International Water Association (IWA) Beijing P.R. China, pp 564–572
- Gu J-D, Cheung KH (2001) Phenotypic expression of *Vogesella indigofera* upon exposure to hexavalent chromium, Cr⁶⁺. *World J Microbiol Biotechnol* 17:475–480
- Gu J-D, Belay B, Mitchell R (2001) Protection of catheter surfaces from adhesion of *Pseudomonas aeruginosa* by a combination of silver ions and lectins. *World J Microbiol Biotechnol* 17:173–179
- Gu J-D, Gu J-G, Shi HC, Li XY (2001b) Simulating anaerobic landfill conditions in bioreactors and testing polymer degradability using poly(β -hydroxybutyrate-co-16 % valerate) and cellulose acetates (DS 1.7 and 2.5) *Water Sci Technol*
- Guezennec J, Ortega-Morales O, Raguene G, Geesey G (1998) Bacterial colonization of artificial substrate in the vicinity of deep-sea hydrothermal vents. *FEMS Microbiol Ecol* 26:89–99
- Gujer W, Zehnder AJB (1983) Conversion processes in anaerobic digestion. *Water Sci Technol* 15:127–167
- Gunjala KR, Sulflita JM (1993) Environmental factors influencing methanogenesis from refuse in landfill samples. *Environ Sci Technol* 27:1176–1181
- Hadley RF (1948) Corrosion by micro-organisms in aqueous and soil environments. In: Uhlig HH (ed) The corrosion handbook. Wiley, New York, pp 466–481
- Hahn PO, Rubloff GW, Bartha JW, Legoues F, Tromp R, Ho PS (1985) Chemical interactions at metal-polymer interfaces. *Mat Res Soc Symp Proc* 40:251–263
- Hamilton WA (1985) Sulphate-reducing bacteria and anaerobic corrosion. *Ann Rev Microbiol* 39:195–217
- Hamilton JD, Reinert KH, Hogan JV, Lord WV (1995) Polymers as solid waste in municipal landfills. *J Air Waste Manag Assoc* 43:247–251
- Hanert HH (1981) The Genus *Siderocapsa* (and other iron- or manganese-oxidizing eubacteria). In: Starr MP, Stolp H, Trüper HG, Balow A, Schlegel HG (eds) The prokaryotes, vol 1. Springer, New York, pp 1049–1060, <http://www.prokaryotes.com>
- Hass H, Herfurth E, Stöffler G, Redl B (1992) Purification, characterization and partial amino acid sequences of a xylanase produced by *Penicillium chrysogenum*. *Biochim Biophys Acta* 1117:279–286
- Heisey RM, Papadatos S (1995) Isolation of microorganisms able to metabolize purified natural rubber. *Appl Environ Microbiol* 61:3092–3097
- Hernandez G, Kucera V, Thierry D, Pedersen A, Hermansson M (1994) Corrosion inhibition of steel by bacteria. *Corrosion* 50:603–608
- Hespell RB, O'Bryan-Shah PJ (1988) Esterase activities in *Butyrivibrio fibrisolvens* strains. *Appl Environ Microbiol* 54:1917–1922
- Hill EC (1987) Microbial problems in the off-shore oil industry. Institute of Petroleum, London, pp 25–28
- Hirsch P, Eckhardt F, Palmer RJ (1995a) Fungi active in weathering of rock and stone monuments. *Can J Bot* 73:1384–1390
- Hirsch P, Eckhardt FEW, Palmer RJ Jr (1995b) Methods for the study of rock-inhabiting microorganisms – a mini review. *J Microbiol Meth* 23:143–167
- Holland KT, Knapp JS, Shoesmith JG (1986) Industrial applications of anaerobes. In: Anaerobic bacteria. Chapman and Hall, New York, pp 165–188
- Holmes PA, Wright LF, Collins SH (1985) β -hydroxybutyrate polymers. European Patent Application EP 52, 459
- Holmström C, Rittschof D, Kjelleberg S (1992) Inhibition of settlement by larvae of *Balanus amphitrite* and *Ciona intestinalis* by a surface-colonizing marine bacterium. *Appl Environ Microbiol* 58:2111–2115
- Huang C-T, James G, Pitt WG, Stewart PS (1996) Effects of ultrasonic treatment on the efficacy of gentamicin against established *Pseudomonas aeruginosa* biofilms. *Colloid Surf B Biointerf* 6:235–242
- Hugenholtz P, Pitulle C, Hershberger KL, Pace NR (1998) Novel division level bacterial diversity in a Yellowstone Hot Spring. *J Bacteriol* 180:366–376
- Hugo WB (1995) A brief history of heat, chemical and radiation preservation and disinfection. *Int Biodeter Biodegr* 35:197–217
- Hungate RE (1969) A roll tube method for cultivation of strict anaerobes. In: Norris JR, Ribbons DW (eds) Methods in microbiology, vol 38. Academic, New York, pp 117–132
- Hutchinson AJ, Johnson JB, Thompson GE, Wood GC, Sage PW, Cooke MJ (1993) Stone degradation due to wet deposition of pollutants. *Corrosion Sci* 34:1881–1898
- Illmer P, Schinner F (1999) Influence of nutrient solution on Al-tolerance of *Pseudomonas* sp. *FEMS Microbiol Lett* 170:187–190
- Iman SH, Gould JM (1990) Adhesion of an amyolytic Arthrobracter sp. to starch-containing plastic films. *Appl Environ Microbiol* 56:872–876
- Iman SH, Gould JM, Gordon SH, Kinney MP, Ramsey AM, Tosteson TR (1992) Fate of starch-containing plastic films exposed in aquatic habitats. *Curr Microbiol* 25:1–8
- Islam M, Thompson NG, Lankard DR, Virmani YP (1995) Quantitative identification of environmental factors in corrosion induced deterioration of reinforced bridge structures. National Association of Corrosion Engineers, Houston
- Iverson WP (1981) An overview of the anaerobic corrosion of underground metallic structures, evidence for a new mechanism. In: Escalante E (ed) Underground corrosion. American Society for Testing and Materials, Philadelphia, Technical Publication No. 741, pp 33–52
- Iverson WP, Olsen GJ (1983) Anaerobic corrosion by sulfate-reducing bacteria due to highly reactive volatile phosphorus compounds. In: Microbial corrosion. The Metal Society, London, pp 46–53
- Iverson WP (1984) Mechanism of anaerobic corrosion of steel by sulfate reducing bacteria. *Mat Perf* 23:28–30
- Iverson WP, Olsen GJ (1984) Problems relating to sulfate-reducing bacteria in the petroleum industry. In: Atlas RM (ed) Petroleum microbiology. Macmillan, New York, pp 619–641

- Iverson WP, Olsen GJ, Heverly LF (1986) The role of phosphorus and hydrogen sulfide in the anaerobic corrosion of iron and the possible detection of this corrosion by an electrochemical noise technique. In: Dexter SC (ed) Biological influenced corrosion. National Association of Corrosion Engineers, Houston, pp 154–161
- Jain KK, Mishra AK, Singh T (1993) Biodeterioration of stone: a review of mechanisms involved. In: Garg KL, Garg N, Mukerji KG (eds) Recent advances in biodeterioration and biodegradation. Naya Prokash, Calcutta, pp 323–354
- Jayaraman A, Earthman JC, Wood TK (1997) Corrosion inhibition by aerobic biofilms on SAE 1018 steel. *Appl Microbiol Biotechnol* 47:62–68
- Jayaraman A, Ornek D, Duarte DA, Lee C-C, Wood TK (1999) Axenic aerobic biofilms inhibit corrosion of copper and aluminum. *Appl Microbiol Biotechnol* 52:787–790
- Jazsa P-G, Kußmaul M, Bock E (1996a) Simulation of concrete corrosion by nitrifying bacteria. In: Sand W (ed) DECHEMA Monographs, vol 133: biodeterioration and biodegradation. VCH Verlagsgesellschaft, Frankfurt, pp 127–134
- Jazsa P-G, Stüven R, Bock E, Kußmaul M (1996b) Statistical data analysis of microbially influenced deterioration of concrete. In: Sand W (ed) DECHEMA monographs, vol 133: Biodeterioration and Biodegradation VCH Verlagsgesellschaft Frankfurt, pp 199–208
- Jensen RJ (1987) Polyimides as interlayer dielectrics for high-performance interconnections of integrated circuits. In: Bouwden MJ, Turner SR (eds) Polymers for high technology: electronics and photonics. American Chemical Society, ACS Symp. Ser. 346, Washington, DC, pp 466–483
- Jensen RA (1992) Marine bioadhesive: role for chemosensory recognition in a marine invertebrate. *Biofouling* 5:177–193
- John ME, Keller G (1996) Metabolic pathway engineering in cotton: biosynthesis of polyhydroxybutyrate in fiber cells. *Proc Natl Acad Sci USA* 93:12768–12773
- Jones-Meehan J, Vasanth KL, Conrad RK, Fernandez M, Little BJ, Ray RI (1994a) Corrosion resistance of several conductive caulks and sealants from marine field tests and laboratory studies with marine, mixed communities containing sulfate-reducing bacteria (SRB). In: Kearns JR, Little BJ (eds) Microbiologically influenced corrosion testing. American Society for Testing and Materials, Philadelphia, ASTM STP 1232, pp 217–233
- Jones-Meehan J, Walch M, Little BJ, Ray RI, Mansfeld FB (1994b) Effect of mixed sulfate-reducing bacterial communities on coatings. In: Geesey GG, Lewandowski Z, Flemming HC (eds) Biofouling and biocorrosion in industrial water systems. Lewis, Boca Raton, pp 107–135
- Jorgensen BB (1988) Ecology of the sulphur cycle: oxidative pathways in sediments. In: Cole JA, Ferguson SJ (eds) The nitrogen and sulphur cycles. Cambridge University Press, New York, pp 31–63
- Karlsson S, Ljungquist O, Albertsson A-C (1988) Biodegradation of polyethylene and the influence of surfactants. *Polym Degr Stab* 21:237–250
- Kawai F, Yamanaka H (1986) Biodegradation of polyethylene glycol by symbiotic mixed culture (obligate mutualism). *Arch Microbiol* 146:125–129
- Kawai F (1987) The biochemistry of degradation of polyethers. *CRC Biotechnol* 6:273–307
- Kawai F, Moriya F (1991) Bacterial assimilation of polytetramethylene glycol. *J Ferment Bioeng* 71:1–5
- Keevil CW, Mackerness CW (1990) Biocide treatment of biofilms. *Int Biodeter* 26:169–179
- Kelley DP (1981) Introduction to the chemolithotrophic bacteria. In: Starr MP, Stolp H, Trüper HG, Balow A, Schlegel HG (eds) The prokaryotes. Springer, New York, pp 1023–1036, <http://www.prokaryotes.com>
- Kelley K, Ishino Y, Ishida H (1987) Fourier transform IR reflection techniques for characterization of polyimide films on copper substrates. *Thin Solid Films* 154:271–279
- Kelly DP (1981) Oxidation of sulphur compounds. In: Cole JA, Ferguson SJ (eds) The nitrogen cycle. Cambridge University Press, New York, pp 997–1004
- Kelly-Wintenberg K, Montie TC (1994) Chemotaxis to oligopeptides by *Pseudomonas aeruginosa*. *Appl Environ Microbiol* 60:363–367
- Kemnitz JE, McCarthy SP, Gross RA (1992) Poly(β -hydroxybutyrate) stereoisomers: a model study of the effects of stereochemical and morphological variables on polymer biological degradability. *Macromolecules* 22:5927–5934
- Kemnitz JE, McCarthy SP, Gross RA (1993) Syndiospecific ring-opening polymerization of β -butyrolactone to form predominantly syndiotactic poly(β -hydroxybutyrate) using Tin (IV) catalysts. *Macromolecules* 23:6143–6150
- Kessi J, Ramuz M, Wehrli E, Spycher M, Bachofen R (1999) Reduction of selenite and detoxification of elemental selenium by the phototrophic bacterium *Rhodospirillum rubrum*. *Appl Environ Microbiol* 65:4734–4740
- Kim O, Gross RA, Rutherford DR (1995) Bioengineering of poly (β -hydroxyalkanoates) for advanced material applications: incorporation of cyano and nitrophenoxy side chain substituents. *Can J Microbiol* 41(Suppl):32–43
- Kim B-K, de Macario EC, Nölling J, Daniels L (1996) Isolation and characterization of a copper-resistant methanogen from a copper-mining soil samples. *Appl Environ Microbiol* 62:2629–2635
- King B, Eggins HOW (1972) Some observations on decay mechanisms of microfungi deteriorating wood. In: Walters AH, Hueck-van der Plas EH (eds) Biodeterioration of materials. Halsted Press/Wiley, New York, pp 145–151
- Klaus T, Joerger R, Olsson E, Granqvist CG (1999) Silver-based crystalline nanoparticles, microbially fabricated. *Proc Natl Acad Sci USA* 96:13611–13614
- Kluyver AJ, van Niel CB (1956) Life's flexibility, microbial adaptation. In: Kluyver AJ, van Niel CB (eds) The microbe's contribution to biology. Harvard University Press, Cambridge, pp 93–129
- Knudsen JG (1981) Fouling of heat transfer surfaces. In: Marto PJ (ed) Power condenser heat transfer technology. Hemisphere, New York, pp 57–82
- Knyazev VM, Korolkov VI, Viktorov AN, Pozharskiy GO, Petrova LN, Gorshkov VP (1986) Sanitary and microbiological aspects of closed environment occupied by people and animals (in Russian) *Kosmicheskaya Biologiya i Aviakosmicheskaya Meditsina* 20:80–82
- Kobrin G, Tatnall RE (1993) Introduction a practical manual on microbiological influenced corrosion. NACE International, Houston, pp 68–72
- Koenig DW, Mishra SK, Pierson DL (1995) Removal of Burkholderia Cepacia biofilms with oxidants. *Biofouling* 9:51–62
- Kong K, Johnstone DL, Yonge DR, Petersen JN, Brouns TM (1994) Long-term intracellular chromium partitioning with subsurface bacteria. *Appl Microbiol Biotechnol* 42:403–407
- Konhauser KO, Schultze-Lam S, Ferris FG, Fyfe WS, Longstaffe FJ, Beveridge TJ (1994) Mineral precipitation by epilithic biofilms in the Speed River, Ontario, Canada. *Appl Environ Microbiol* 60:549–553
- Korber DR, Lawrence JR, Sutton B, Caldwell DE (1989) Effect of laminar flow velocity on the kinetics of surface recolonization by Mot^+ and Mot^- *Pseudomonas fluorescens*. *Microb Ecol* 18:1–9
- Kormelink FJM, Voragen J (1993) Degradation of different [(glucurono)arabino] xylans by a combination of purified xylan-degrading enzymes. *Appl Microbiol Biotechnol* 38:688–695
- Krieg NR, Holt JG (1984) Bergey's manual of systematic bacteriology. Williams and Wilkins, Baltimore, p 1, <http://www.cme.msu.edu/bergeys>
- Krumbein WE (1968) Inquiry on biological decomposition: the influence of microflora on the decomposition of building stone and its dependence on edaphic factors. *Zeitschrift für Allgemeine Microbiologie* 8:107–117
- Kuonen JG, Tuovinen OH (1981) The genera Thiobacillus and Thiomicrospira. In: Starr MP, Stolp H, Trüper HG, Balow A, Schlegel HG (eds) The prokaryotes. Springer, New York, pp 1023–1036, <http://www.prokaryotes.com>
- KulpaCF, Baker CJ (1990) Involvement of sulfur-oxidizing bacteria in concrete deterioration. In: Dowling NJ, Mittelman MW, Danko JC (eds) Microbially influenced corrosion and biodeterioration. National Association of Corrosion Engineers, Houston, pp 4/7–4/9
- Kumar R, Venkataraman A (1996) Biodeterioration of stone monuments in tropical regions: a review of current research status. The Getty Conservation Institute, Marina del Rey, pp 1–63
- Lai JH (1989) Polymers for electronic applications. CRC Press, Boca Raton, pp 23–24
- Lappin-Scott H, Costerton JW, Marrie TJ (1992) Biofilms and biofouling. In: Encyclopedia of microbiology, vol 1, pp 277–284
- Lauwers AM, Heinen W (1974) Biodegradation and utilization of silica and quartz. *Arch Microbiol* 95:67–78

- Lawrence JR, Delaquis PJ, Korber DR, Caldwell DE (1987) Behavior of *Pseudomonas fluorescens* within the hydrodynamic boundary layers of surface microenvironments. *Arch Ecol* 14:1–14
- Lea FM, Desch CH (1936) The chemistry of cement and concrete. Edward Arnold, London, pp 16–17
- Lee JA (1948) Plastics. In: Uhlrig HH (ed) The corrosion handbook. Wiley, New York, pp 359–365
- Lee SF, Forsberg CW, Gibbins LN (1985) Xylanolytic activity of *Clostridium acetobutylicum*. *Appl Environ Microbiol* 50:1068–1076
- Lee SF, Forsberg CW, Rattray JB (1987a) Purification and characterization of two endoxylanases from *Clostridium acetobutylicum*. ATCC 824. *Appl Environ Microbiol* 53:644–650
- Lee H, To RJB, Latta RK, Biely P, Schneider H (1987b) Some properties of extracellular acetylxyylan esterase produced by the yeast *Rhodotorula mucilaginosa*. *Appl Environ Microbiol* 53:2831–2834
- Lee W, Lewandowski Z, Okabe S, Characklis WG, Avci R (1993a) Corrosion of mild steel underneath aerobic biofilms containing sulfate-reducing bacteria, part I: at low dissolved oxygen concentration. *Biofouling* 7:197–216
- Lee W, Lewandowski Z, Morrison M, Characklis WG, Avci R, Nielsen PH (1993b) Corrosion of mild steel underneath aerobic biofilms containing sulfate-reducing bacteria, part II: at high dissolved oxygen concentration. *Biofouling* 7:217–239
- Lee Y-E, Lowe SE, Zeikus JG (1993c) Regulation and characterization of xylanolytic enzymes of Thermoanaerobacterium saccharolyticum B6A-RI. *Appl Environ Microbiol* 59:763–771
- Lee W, Lewandowski Z, Nielsen PH, Hamilton WA (1995) Role of sulfate-reducing bacteria in corrosion of mild steel: a review. *Biofouling* 8:165–194
- Lefebvre-Drouet E, Rousseau MF (1995) Dissolution de différents oxyhydroxydes de fer par voie chimique et par voie biologique: importance des bactéries redutrices. *Soil Biol Biochem* 27:1041–1050
- Lemaire J, Dabin P, Arnaud R (1992) Mechanisms of abiotic degradation of synthetic polymers. In: Vert M, Feijen J, Albertsson A, Scott G, Chiellini E (eds) Biodegradable polymers and plastics. Royal Society of Chemistry, Cambridge, pp 30–39
- Lemoigne M (1926) Produits de déshydratation et de polymérisation de l'acide β -oxybutyrique. *Bull Soc Chim Biol (Paris)* 8:770–782
- Lewandowski Z, Stoodley P, Altobelli S (1995) Experimental and conceptual studies on mass transport in biofilms. *Water Sci Technol* 31:153–162
- Leyden RN, Basulis DI (1989) Adhesion and electrical insulation of thin polymeric coatings under saline exposure. In: Hanker JS, Giammara BL (eds) Biomedical materials and devices materials, vol 10. Research Society, Pittsburgh, pp 627–633
- L'Hostis E, Compère C, Festy D, Tribollet B, Deslouis C (1997) Characterization of biofilms formed on gold in natural seawater by oxygen diffusion analysis. *Corrosion* 53:4–10
- Li D, Lu R (1990) Purification and properties of periplasmic hydrogenase from *Desulfovibrio vulgaris* D-2. *Acta Microbiol Sinica* 30:267–272
- Li D, Ma Y, Flanagan WF, Lichter BD, Wikswo JP Jr (1997) Detection of hidden corrosion of aircraft aluminum alloy by magnetometry using a superconducting quantum interference device. *Corrosion* 53:93–98
- Liken GE (1981) Some perspectives of the major biogeochemical cycles: scope 17. Wiley, New York, pp 93–112
- Lin C, Olson BH (1995) Occurrence of cop-like copper resistance genes among bacteria isolated from a water distribution system. *Can J Microbiol* 41:642–646
- Little B, Wagner P, Gerchakov SM, Walch M, Mitchell R (1986a) The involvement of a thermophilic bacterium in corrosion processes. *Corrosion* 42:533–536
- Little BJ, Wagner P, Maki JS, Mitchell R (1986b) Factors influencing the adhesion of microorganisms to surfaces. *J Adhesion* 20:187–210
- Little BJ, Depalma JR (1988) Marine biofouling. *Treat Mat Sci Technol* 28:89–119
- Little B, Wagner P, Characklis WG, Lee W (1990) Microbial corrosion. In: Characklis WG, Marshall KC (eds) Biofilms. Wiley, New York, pp 635–670
- Little BJ, Wagner P, Jones-Meehan J (1994) Sulfur isotopic fractionation in sulfide corrosion products as an indicator for microbiologically influenced corrosion (MIC). In: Kearns JR, Little BJ (eds) Microbiologically influenced corrosion testing. American Society for Testing and Materials, Philadelphia PA ASTM STP 1232, pp 180–187
- Liu X, Roe F, Jesaitis A, Lewandoski Z (1998) Resistance of biofilms to the catalase inhibitor 3-amino-1,2,4-triazole. *Biotechnol Bioeng* 59:156–162
- Lovley DR, Stolz JF, Nord GL, Phillips EJ (1987) Anaerobic production of magnetite by a dissimilatory iron-reducing microorganism. *Nature (Lond)* 330:252–254
- Lovley DR (1991) Dissimilatory Fe(III) and Mn(IV) reduction. *Microbiol Rev* 55:259–287
- Lovley DR, Phillips EJP (1994) Reduction of chromate by *Desulfovibrio vulgaris* and its c_3 cytochrome. *Appl Environ Microbiol* 60:726–728
- Lü R, Liu Q, Xiao C, Bai S, Chen H, Wang F (1984) Study on microbicidal efficiency of chlorine dioxide for fouling harmful microbes in desalting water systems. *Acta Microbiol Sinica* 24:243–249
- Lü R, Liu Q, Zhang Y, Xiao C (1989) Studies on harmful microbes in recirculating cooling water system of oil refinery. *Acta Microbiol Sinica* 29:204–215
- Lusty CJ, Doudoroff M (1966) Poly- β -hydroxybutyrate depolymerases of *Pseudomonas lemoignei*. *Proc Natl Acad Sci USA* 56:960–965
- Lüthi E, Jasmal NB, Bergquist PL (1990a) Overproduction of an acetylxyylan esterase from the extreme thermophile '*Caldocellum saccharolyticum*' in *Escherichia coli*. *Appl Microbiol Biotechnol* 34:214–219
- Lüthi E, Love DR, McAnulty J, Wallace C, Caughey PA, Saul D, Bergquist PL (1990b) Cloning, sequence analysis, and expression of genes encoding xylan-degrading enzymes from the thermophile '*Caldocellum saccharolyticum*'. *Appl Environ Microbiol* 56:1017–1024
- Luu WC, Kuo HS, Wu JK (1997) Hydrogen permeation through nickel-plated steels. *Corrosion Sci* 39:1051–1059
- Lynch JL, Edyvean RGJ (1988) Biofouling in oilfield water systems – a review. *Biofouling* 1:147–162
- MacDonald MJ, Hartley DL, Speedie MK (1985) Location of cellulolytic enzyme activity in the marine fungus *Trichocladium achrasporum*. *Can J Microbiol* 31:145–148
- MacDonald RM (1986) Nitrification in soil: an introductory history. In: Prosser JI (ed) Nitrification. IRL Press, Oxford, pp 1–16
- MacKenzie CR, Bilous D, Schneider H, Johnson KG (1987) Induction of cellulolytic and xylanolytic enzyme systems in *Streptomyces* spp. *Appl Environ Microbiol* 53:2853–2839
- Madigan MT, Martinko JM, Parker J (2000) Brock biology of microorganisms, 9th edn. Prentice-Hall, Upper Saddle River
- Maki JS, Rittschof D, Schmidt AR, Snyder AS, Mitchell R (1989) Factors controlling attachment of bryozoan larvae: a comparison of bacterial films and unfiled surfaces. *Biol Bull* 177:295–302
- Maki JS, Little BJ, Wagner P, Mitchell R (1990a) Biofilm formation on metal surfaces in Antarctic waters. *Biofouling* 2:27–38
- Maki JS, Rittschof D, Samuelson MO, Szwedzyk U, Yule AB, Kjelleberg S, Costlow JD, Mitchell R (1990b) Effect of marine bacteria and their exopolymers on attachment of barnacle cypris larvae. *Bull Marine Sci* 46:499–511
- Mansfeld F, Shih H, Postyn A, Devinny J, Islander R, Chen CL (1990) Corrosion monitoring and control in concrete sewer pipes. National Association of Corrosion Engineers, Houston
- Mansfeld F (1994) Effectiveness of ion vapor-deposited aluminum as a primer for epoxy and urethane topcoats. *Corrosion* 50:609–612
- Mansfeld F (1995) Use of electrochemical impedance spectroscopy for the study of corrosion by polymer coatings. *J Appl Electrochem* 25:187–202
- Margulis L (1981) The endosymbiotic theory. In: Margulis L (ed) Symbiosis in cell evolution. W. H. Freeman, San Francisco, pp 1–14
- Marshall KC, Stout R, Mitchell R (1971) Mechanism of the initial events in the sorption of marine bacteria to surfaces. *J Gen Microbiol* 68:337–348
- Marshall KC (1976) Solid-liquid and solid-gas interfaces. In: Marshall KC (ed) Interfaces in microbial ecology. Harvard University Press, Cambridge, pp 27–52
- Marshall KC (1980) Adsorption of microorganisms to soils and sediments. In: Bitton G, Marshall KC (eds) Adsorption of microorganisms to surfaces. Wiley, New York, pp 317–329
- Marshall KC (1992) Biofilms: an overview of bacterial adhesion, activity, and control at surfaces. *ASM News* 58:202–207

- Marthamuthu S, Rajagopal G, Sathianarayanan S, Eashwar M, Balakrishnan K (1995) A photoelectrochemical approach to the ennoblement process: proposal of an adsorbed inhibitor theory. *Biofouling* 8:223–232
- Mas-Castellà J, Urmeneta J, Lafuente R, Navarrete A, Guerrero R (1995) Biodegradation of poly- β -hydroxyalkanoates in anaerobic sediments. *Int Biodeter Biodegr* 35:155–174
- Matamala G, Smeltzer W, Droguett G (1994) Use of tannin anticorrosive reaction primer to improve traditional coating systems. *Corrosion* 4:270–275
- Matis KA, Zouboulis AI, Grioriadou AA, Lazaridis NK, Ekateriniadou LV (1996) Metal biosorption-flotation, application to cadmium removal. *Appl Microbiol Biotechnol* 45:569–573
- Mattila K, Carpen L, Hakkarainen T, Salkinoja-Salonen MS (1997) Biofilm development during ennoblement of stainless steel in Baltic Sea water: a microscopic study. *Int Biodeter Biodegr* 40:1–10
- May E, Lewis FJ, Pereira S, Taylor S, Seaward MRD (1993) Microbial deterioration of building stone – a review. *Biodeter Abstr* 7:109–123
- Mayr E (1998) Two empires or three? *Proc Natl Acad Sci USA* 95:9720–9723
- McCain JW, Mirocha CJ (1995) Screening computer diskettes and other magnetic media for susceptibility to fungal colonization. *Int Biodeter Biodegr* 33:255–268
- McFeters GA (1991) Disinfection susceptibility of waterborne *Pseudomonads* and *Legionellae* under simulated space vehicle conditions. Intersociety Conference on Environmental Systems San Francisco CA SAE Technical Paper 911404, ICE
- McFeters GA, Yu FP, Pyle BH, Stewart PS (1995) Physiological methods to study biofilm disinfection. *J Ind Microbiol* 15:333–338
- McLean RJC, Nickel JC, Olson ME (1995) Biofilm associated urinary tract infections. In: Lappin-Scott HM, Costerton JW (eds) *Microbial biofilms*. Cambridge University Press, Cambridge, pp 261–273
- McLean RJC, Whiteley M, Stickler DJ, Fuqua WC (1997) Evidence of autoinducer activity in naturally occurring biofilms. *FEMS Microbiol Lett* 154:259–263
- Mergaert J, Webb A, Anderson C, Wouters A, Swings J (1993) Microbial degradation of poly(3-hydroxybutyrate) and poly(3-hydroxybutyrate-co-3-hydroxyvalerate) in soils. *Appl Environ Microbiol* 59:3233–3238
- Mergeay M (1991) Towards an understanding of the genetics of bacterial metal resistance. *Trends Biotechnol* 9:17–24
- Meshkov D (1994) The influence of spaceflight conditions on sensitization of men to bacterial and chemical allergens. 45th Congress of the International Astronautical Confederation Congress, Jerusalem Israel IAF/IAA-94-G.1.125
- Meyer L (1864) Chemische untersuchungen der themen zu landeck in der grafenschaft glatz. *J Prakt Chem* 91:1–15
- Milde K, Sand W, Wolff W, Bock E (1983) Thiobacilli of the concrete walls of the Hamburg sewer system. *J Gen Microbiol* 129:1327–1333
- Millard SG, Gowers KR, Bungey JH (1995) Galvanostatic pulse techniques: a rapid method of assessing corrosion rates of steel in concrete structure. NACE International Corrosion, Houston
- Miller JDA (1970) *Microbial aspects of metallurgy*. Elsevier, New York, pp 61–105
- Mills AL, Powelson DK (1996) Bacterial interactions with surfaces in soils. In: Fletcher M (ed) *Bacterial adhesion: molecular and ecological diversity*. Wiley-Liss, New York, pp 25–57
- Milstein O, Gersonde R, Huttermann A, Chen M-J, Meister JJ (1992) Fungal biodegradation of lignopolystyrene graft copolymers. *Appl Environ Microbiol* 58:3225–3232
- Mitchell R, Maki JS (1989) Microbial surface films and their influence on larval settlement and metamorphosis in the marine environment. In: Thompson MF, Sarojini R, Nagabhushanam R (eds) *Marine biodeterioration: advanced techniques applicable to the Indian Ocean*. Oxford & IBH, New Delhi, pp 489–497
- Mitchell R, Gu JD, Roman M, Soukup S (1996) Hazards to space missions from microbial biofilms. In: Sand W (ed) *Biodeterioration and biodegradation*. VCH Verlagsgesellschaft, Frankfurt, DEHEMA Monographs, vol 133, pp 3–16
- Mitchell R, Gu J-D (2000) Changes in the biofilm microflora of limestone caused by atmospheric pollutants. *Int Biodeter Biodegr* 46:299–303
- Mittelman MW, Geesey G (1985) Copper-binding characteristics of exopolymers from a freshwater-sediment bacterium. *Appl Environ Microbiol* 49:846–851
- Mittelman MW (1995) Biofilm development in purified water systems. In: Lappin-Scott HM, Costerton JW (eds) *Microbial biofilms*. Cambridge University Press, Cambridge, pp 133–147
- Mittelman MW, Danko JC (1995) Corrosion of a concrete dam structure: evidence of microbially influenced corrosion activity. In: Angell P et al (eds) 1995 International conference on microbial influenced corrosion. National Association of Corrosion Engineers, Houston TX, pp 15/1–15/7
- Mittelman MW (1996) Adhesion to biomaterials. In: Fletcher M (ed) *Bacterial adhesion: molecular and ecological diversity*. Wiley-Liss, New York, pp 89–127
- Mitton B, Ford TE, LaPointe E, Mitchell R (1993) Biodegradation of complex polymeric materials. National Association of Corrosion Engineers, Houston
- Mitton DB, Latanison RM, Bellucci F (1996) The effects of post-cure annealing on the protective properties of polyimides on chromium substrates. *J Electrochem Soc* 143:3307–3316
- Mitton DB, Toshima S, Latanison RM, Bellucci F, Ford TE, Gu J-D, Mitchell R (1998) Biodegradation of polymer-coated metallic substrates. In: Bierwagen GP (ed) *Organic coatings for corrosion control*, vol 689. ACS Symp. Ser, ACS Washington, DC, pp 211–222
- Moat AG, Foster JW (1988) Growth and its regulation. In: Moat AG, Foster JW, Spector MP, Sector MP (eds) *Microbial physiology*, 2nd edn. Wiley, New York, pp 523–578
- Moore L, Postle M (1994) Risk-benefit analysis and case study on tributyl tin. *Int Biodeter Biodegr* 34:401–412
- Moosavi AN, Dawson JL, King RA (1986) The effect of sulfate-reducing bacteria on the corrosion of reinforced concrete. In: Dexter SC (ed) *Biologically induced corrosion: proceedings of the international conference on biologically induced corrosion*. National Association of Corrosion Engineers, Houston, pp 291–308
- Morton RL, Yanko WA, Graham DW, Arnold RG (1991) Relationships between metal concentrations and crown corrosion in Los Angeles County sewers. *Res J WPCF* 63:779–798
- Murray FES, Mitchell R, Ford T (1993) In: *Experimental methods for the study of microbial mediated corrosion*. NACE International, Houston
- Myers T (1988) Failing the test: germicides or use dilution methodology? *ASM News* 54:19–21
- Nakagawa H, Akihawa S, Suenaga T, Taniguchi Y, Yoda K (1993) Fiber reinforced concrete: developments and application to buildings. *Adv Composite Mat* 3:123–131
- Nakajima-Kambe T, Onuma F, Kimpara N, Nakahara T (1995) Isolation and characterization of a bacterium which utilizes polyester polyurethane as a sole carbon and energy source. *FEMS Microbiol Lett* 129:39–42
- Nakanishi K, Marui M, Yasui T (1992) Comparison of xylan and methyl β -xyloside-induced xylanases from *Streptomyces* sp. *J Ferment Bioeng* 74:392–394
- Nakayama K, Saito T, Fukui Y, Shirakura Y, Tomita K (1985) Purification and properties of extracellular poly(3-hydroxybutyrate) depolymerases from *Pseudomonas lemoignei*. *Biochim Biophys Acta* 827:63–72
- Narayan R (1993) Biodegradation of polymeric materials (anthropogenic macromolecules) during composting. In: Hoitink HAJ, Keener HM (eds) *Science and engineering of composting: design, environmental, microbiological and utilization aspects*. Renaissance, Worthington, pp 339–362
- Nefedov Y, Novikova ND, Surovezhin IN (1988) Products of biodegradation of polymers as a factor in the possible pollution of the air of hermetically sealed environments with toxic substances (in Russian) *Kosmicheskaya Biologiya i Aviakosmicheskaya Medistina* 22:67–71
- Neu T (1996) Significance of bacterial surface-active compounds in interaction of bacteria with interfaces. *Microbiol Rev* 60:151–166
- Nieboer E, Gibson BL, Oxman AD, Kramer JR (1995) Health effects of aluminum: a critical review with emphasis on aluminum in drinking water. *Environ Rev* 3:29–81
- Nielsen PH, Lee W, Lewandowski Z, Morison M, Characklis WG (1993) Corrosion of mild steel in an alternating oxic and anoxic biofilm system. *Biofouling* 7:267–284
- Novikova ND, Zalogoyev SN (1985) Formation of volatile substances during polymer destruction by *Pseudomonas aeruginosa* (in Russian) *Kosmicheskaya Biologiya i Aviakosmicheskaya Medistina* 19:74–76

- Novikova ND, Orlova MI, Dyachenko MB (1986) Reproductive capacity of microflora on polymers used in sealed environments (in Russian) *Kosmicheskaya Biologiya i Aviakosmicheskaya Medistina* 20:71–73
- Nozhevnikova AN, Kotsyurbenko OR, Simankova MV (1994) Acetogenesis. In: Drake HL (ed) *Acetogenesis at low temperature*. Chapman and Hall, New York, pp 416–431
- NRC (National Research Council) (1987) *Agenda for advancing electrochemical corrosion science and technology*. National Academy Press, Washington, DC, Publication NMAB438-2 87–96
- Odian G (1991) Reactions of polymers. In: Odian G (ed) *Principles of polymerization*, 3rd edn. Wiley, New York, pp 691–745
- Odom JM (1993) Industrial and environmental activities of sulfate-reducing bacteria. In: Odom JM, Singleton R Jr (eds) *The sulfate-reducing bacteria: contemporary perspectives*. Springer, New York, pp 189–210
- Odom JM, Singleton R Jr (1993) *The sulfate-reducing bacteria: contemporary perspectives*. Springer, New York, p 289
- Olesen BH, Avci R, Lewandowski Z (1998) Ennoblement of stainless steel studied by X-ray photoelectron spectroscopy. *NACE International, Houston TX Corrosion*
- Olmstead WM, Hamlin H (1900) Converting portions of the Los Angeles outfall sewer into a septic tank. *Engin 1199 News* 44:317–318
- Ortega-Calvo JJ, Hernandez-Marine M, Saiz-Jimenez C (1991) Biodeterioration of building materials by cyanobacteria and algae. *Int Biodeter* 28:165–185
- Ortega-Calvo JJ, Sanchez-Castillo PM, Hernandez-Marine M, Saiz-Jimenez C (1993) Isolation and characterization of epilithic chlorophytes and cyanobacteria from two Spanish cathedrals (Salamanca and Toledo). *Nova Hedwigia* 57:239–253
- Ortega-Calvo JJ, Arino X, Hernandez-Marine M, Saiz-Jimenez C (1995) Factors affecting the weathering and colonization of monuments by phototrophic microorganisms. *Sci Total Environ* 167:329–341
- Ortega-Morales O, Hernandez-Duque G, Borges-Gomez L, Guezennec J (1999) Characterization of epilithic microbial communities associated with Mayan stone monuments in Yucatan, Mexico. *Geomicrobiol J* 16:221–232
- Osswald P, Courtes R, Bauda P, Block JC, Bryers JD, Sunde E (1995) Xenobiotic biodegradation test using attached bacteria in synthetic seawater. *Ecotoxicol Environ Safety* 31:211–217
- O'Toole G, Kaplan HB, Kolter R (2000) Biofilm formation as microbial development. *Ann Rev Microbiol* 54:49–79
- Pace NR (1997) A molecular view of microbial diversity and the biosphere. *Science* 276:734–740
- Padival NA, Weiss JS, Arnold RG (1995) Control of *Thiobacillus* by means of microbial competition: Implications for corrosion of concrete sewers. *Water Environ Res* 67:201–205
- Paradies HH, Haenßel I, Fisher W, Wagner D (1990) Microbial induced corrosion of copper pipes. New York, INCRA Report No. 444 16
- Paradies HH (1995) Chemical and physical aspects of metal biofilms. In: Gaylarde CC, Videla HA (eds) *Bioextraction and biodeterioration*. Cambridge University Press, Cambridge, pp 197–269
- Parikh M, Gross RA, McCarthy SP (1993) The effect of crystalline morphology on enzymatic degradation kinetics. In: Kaplan D, Thomas E, Ching C (eds) *Fundamentals of biodegradable materials and packaging*. Technomic, Lancaster, pp 159–170
- Parker CD (1945a) The corrosion of concrete. 1: the isolation of a species of bacterium associated with the corrosion of concrete exposed to atmospheres containing hydrogen sulphide. *Aust J Exp Biol Med Sci* 23:81–90
- Parker CD (1945b) The corrosion of concrete. 2: the function of *Thiobacillus concretivorus* (nov. spec.) in the corrosion of concrete exposed to atmospheres containing hydrogen sulphide. *Aust J Exp Biol Med Sci* 23:91–98
- Parker CD (1947) Species of sulfur bacteria associated with the corrosion of concrete. *Nature (Lond)* 159:439
- Parker CD, Prisk A (1953) The oxidation of inorganic compounds of sulphur by various sulphur bacteria. *J Gen Microbiol* 8:344–364
- Parker CD, Jackson D (1965) The microbial flora of concrete surfaces. *Hydrogen Sulphide Corrosion of Concrete Sewers Melbourne and Metropolitan Board of Works, Melbourne, Australia Technical Paper No. A8, Part 6*, pp 1–29
- Pedersen K (1996) Investigations of subterranean bacteria in deep crystalline bedrock and their importance for the disposal of nuclear waste. *Can J Microbiol* 42:382–391
- Pendyala J, Avci R, Geesey GG, Stoodley P, Hamilton M, Harkin G (1996) Chemical effect of biofilm colonization on 304 stainless steel. *J Vac Sci Technol A14*:1955–1760
- Peng C-G, Park JK (1994) Principal factors affecting microbiologically influenced corrosion of carbon steel. *Corrosion* 50:669–675
- Pierson DL, Mishra SK (1992) Microbiological challenges of space habitation. 43rd congress of the international astronomical confederation congress, Washington, DC
- Pierson BK, Parenteau MN (2000) Phototrophs in high iron microbial mats: microstructure of mats in iron-depositing hot springs. *FEMS Microbiol Ecol* 32:181–196
- Piervittori R, Salvadori O, Laccisaglia A (1994) Literature on lichens and biodeterioration of stonework I. *Lichenologist* 26:171–192
- Pitt CG (1992) Non-microbial degradation of polyesters: mechanisms and modifications. In: Vert M, Feijen J, Albertsson A, Scott G, Chiellini E (eds) *Biodegradable polymers and plastics*. Royal Society for Chemistry/Redwood Press, Melksham, pp 7–17
- Pometto AL III, Lee B, Johnson KE (1992) Production of an extracellular polyethylene-degrading enzyme(s) by *Streptomyces* species. *Appl Environ Microbiol* 58:731–733
- Pometto AL III, Johnson KE, Kim M (1993) Pure-culture and enzymatic assay for starch-polyethylene degradable plastic biodegradation with *Streptomyces* species. *J Environ Polym Degr* 1:213–221
- Pope DH, Duquette D, Wayner Jr. PC, Johannes AH (1989) In: *Microbiologically influenced corrosion: a state-of-the-art review*, 2nd edn. National Association of Corrosion Engineers, Houston TX MTI Publication No. 13 4 1–3
- Postgate JR (1984) *The sulfate-reducing bacteria*, 2nd edn. Cambridge University Press, New York, pp 132–152
- Potekhina JS, Sherisheva NG, Povetkina LP, Pospelov AP, Rakitina TA, Warnecke F, Gottschalk G (1999) Role of microorganisms in corrosion inhibition of metals in aquatic habitats. *Appl Microbiol Biotechnol* 52:639–646
- Power K, Marshall KC (1988) Cellular growth and reproduction of marine bacteria on surface-bound substrate. *Biofouling* 1:163–174
- Prieto B, Rivas T, Silva B, Carballal R, Lopez de Silanes ME (1995) Colonization by lichens of granite dolments in Galicia (NW Spain). *Int Biodeter Biodegr* 34:47–60
- Pyle BH, Broadaway SC, McFeters GA (1992) Efficacy of copper and silver ions with iodine in the inactivation of *Pseudomonas cepacia*. *J Appl Bacteriol* 72:71–79
- Raychaudhuri S, Sutphin PD, Chang JT, Altman RB (2001) Basic microarray analysis: grouping and feature reduction. *Trends Biotechnol* 19:189–193
- Reese ET (1957) Biological degradation of cellulose derivatives. *Ind Engin Chem* 49:89–93
- Reinsel MA, Sears JT, Stewart PS, McInerney MJ (1996) Control of microbial souring by nitrate, nitrite or glutaraldehyde injection in a sandstone column. *J Ind Microbiol* 17:128–136
- Rethke D (1994) Testing of Russian ECLSS-Sabatier and potable water processor Intersociety Conference on Environmental Systems Friedrichshafen Germany SAE Technical Paper 941252, ICES
- Reynolds TB, Fink GR (2001) Baker's yeast, a model for fungal biofilm formation. *Science* 291:878–881
- Rijnaarts HHM, Norde W, Bouwer EJ, Lyklema J, Zehnder AJB (1993) Bacterial adhesion under static and dynamic conditions. *Appl Environ Microbiol* 59:3255–3265
- Rittman BE (1993) The significance of biofilms in porous media. *Water Res Rev* 29:2195–2202
- Rittschof D, Maki J, Mitchell R, Costlow JD (1986) Ion and neuropharmacological studies of barnacle settlement Netherlands. *J Sea Res* 20:269–275
- Roe FL, Lewandowski Z, Funk T (1996) Simulation microbiologically influenced corrosion by depositing extracellular biopolymers on mild steel surfaces. *Corrosion* 52:744–752
- Rogers J, Dowsett AB, Dennis PJ, Lee JV, Keevil CW (1994) Influence of plumbing materials on biofilm formation and growth of *Legionella pneumophila* in potable water systems. *Appl Environ Microbiol* 60:1842–1851

- Rölleke S, Witte A, Wanner G, Lubitz W (1998) Medieval wall paintings – a habitat for archaea: identification of archaea by denaturing gradient gel electrophoresis (DGGE) of PCR-amplified gene fragments coding for 16S rRNA in a medieval wall painting. *Int Biodeter Biodegr* 41:85–92
- Ross J (1994) An aquatic invader is running amok in U.S. waterways. *Smithsonian* 24:40–51
- Rossmore HW, Rossmore LA (1993) MIC in metalworking processes and hydraulic systems. In: Kobrin G (ed) *A practical manual on microbiologically influenced corrosion*. NACE International, Houston, pp 31–40
- Saito H, Miyata Y, Takazawa H, Takai K, Yamauchi G (1995) Corrosion rate measurements of steel in carbonated concrete. NACE International, Houston TX, *Corrosion*
- Saito T, Suzuki K, Yamamoto J, Fukui T, Miwa K, Tomita K, Nakanishi S, Odani S, Suzuki J-I, Ishikawa K (1989) Cloning, nucleotide sequence, and expression in *Escherichia coli* of the gene for poly-3-hydroxybutyrate depolymerase from *Alcaligenes faecalis*. *J Bacteriol* 171:184–189
- Saiz-Jimenez C (1995) Deposition of anthropogenic compounds on monuments and their effect on airborne microorganisms. *Aerobiologia* 11:161–175
- Saiz-Jimenez C (1997) Biodeterioration vs biodegradation: the role of microorganisms in the removal of pollutants deposited on historic buildings. *Int Biodeter Biodegr* 40:225–232
- Sakaguchi T, Burgess JG, Matsunaga T (1993) Magnetite formation by a sulphate-reducing bacterium. *Nature (Lond)* 253:47–49
- Salama N, Guillemin K, McDaniel TK, Sherlock G, Tompkins L, Falkow S (2000) A whole-genome microarray reveals genetic diversity among *Helicobacter pylori* strains. *Proc Natl Acad Sci USA* 97:14668–14673
- Sánchez A, Ballester A, Blázquez ML, González F, Muñoz J, Hammami A (1999) Biosorption of copper and zinc by *Cymodocea nodosa*. *FEMS Microbiol Rev* 23:527–536
- Sand W, Milde K, Bock E (1983) Simulation of concrete corrosion in a strictly controlled H₂S breeding chamber. In: Rossi G, Torma AE (eds) *Recent progress in biohydrometallurgy associazione mineraria*. Sarda, Italy, pp 667–677
- Sand W, Bock E (1984) Concrete corrosion in the Hamburg sewer system. *Environ Technol Lett* 5:517–528
- Sand W (1987) Importance of hydrogen sulfide, thiosulfate and methylmercaptan for growth of thiobacilli during simulation of concrete corrosion. *Appl Environ Microbiol* 53:1645–1648
- Sand W, Bock E, White DC (1987) Biotest system for rapid evaluation of concrete resistance to sulfur-oxidizing bacteria. *Mat Perf* 26:14–17
- Sand W, Ahlers B, Bock E (1991) The impact of microorganisms — especially nitric acid producing bacteria — on the deterioration of natural stones. In: Baer NS, Sabbioni C, Sors AI (eds) *Science, technology and European cultural heritage*. Butterworth-Heinemann, Oxford, pp 481–484
- Sand W (1997) Microbial mechanisms of deterioration of inorganic substrates — a general mechanistic overview. *Int Biodeter Biodegr* 40:183–190
- Sandaa R-A, Enger O, Torsvik V (1999) Abundance and diversity of Archaea in heavy-metal-contaminated soils. *Appl Environ Microbiol* 65:3293–3297
- Sanders PF, Hamilton WA (1986) Biological and corrosion activities of sulphate-reducing bacteria in industrial process plant. In: Dexter SC (ed) *Biologically induced corrosion: proceedings of the international conference on biologically induced corrosion*. National Association of Corrosion Engineers, Houston, pp 47–68
- Santini JM, Sly LI, Schnagi RD, Macy JM (2000) A new chemolithoautotrophic arsenite-oxidizing bacterium isolated from a gold mine: phylogenetic, physiological, and preliminary biochemical studies. *Appl Environ Microbiol* 66:92–97
- Scamans GM, Hunter JA, Holroyd NJH (1989) A surface-engineering approach to the corrosion aluminum. *Treat Mater Sci Technol* 31:485–500
- Schembri MA, Kjærgaard K, Klemm P (1999) Bioaccumulation of heavy metals by fibrillar designer adhesives. *FEMS Microbiol Lett* 170:363–371
- Schink B, Stieb M (1983) Fermentative degradation of polyethylene glycol by a strictly anaerobic, Gram-negative, nonsporeforming bacterium, *Pelobacter venetianus* sp. nov. *Appl Environ Microbiol* 45:1905–1913
- Schmidt EL (1982) Nitrification in soil. In: Stevenson FJ (ed) *Nitrogen in agricultural soils*. Soil Science Society of America, vol 22, Agronomy Monograph. Madison, pp 253–288
- Schmidt R (1997) Monte Carlo simulation of bioadhesion. *Int Biodeter Biodegr* 40:29–36
- Schmidtt CR (1986) Anomalous microbiological tuberculation and aluminum pitting corrosion — case histories. In: Dexter SC (ed) *Biologically induced corrosion: proceedings of the international conference on biologically induced corrosion*. National Association of Corrosion Engineers, Houston TX, pp 69–75
- Schüler D, Frankel RB (1999) Bacterial magnetosomes: microbiology, biomineralization and biotechnological applications. *Appl Microbiol Biotechnol* 52:464–473
- Schultzen-Lam S, Harauz G, Beveridge TJ (1992) Participation of a cyanobacterial S layer in fine-grain mineral formation. *J Bacteriol* 174:7971–7981
- Selwitz CM (1992) The use of epoxy resins in field projects for stone stabilization. *Mat Res Soc Symp Proc* 267:925–934
- Sequeira CAC, Tiller AK (1988) *Microbial corrosion*, vol 1. Elsevier Science, London/New York, pp 34–36
- Severini F, Gallo R, Ipsale S (1988) Environmental degradation of polypropylene. *Polym Degr Stab* 22:185–194
- Sharp RR, Bryers JB, Jones WG, Shields MS (1998) Activity and stability of a recombinant plasmid-borne TCE degradative pathway in suspended cultures. *Biotechnol Bioeng* 57:287–296
- Siedlerek H, Wagner D, Fischer WR, Paradies HH (1994) Microbiologically influenced corrosion of copper: the ionic transport properties of biopolymers. *Corrosion Sci* 36:1751–1763
- Sneath PHA, Mair NS, Sharpe ME, Holt JG (1986) *Bergey's manual of systematic bacteriology*. Williams and Wilkins, Baltimore, <http://www.cme.msu.edu/bergeys>
- Sneider RP, Chadwick BR, Pembrey R, Jankowski J, Acworth I (1994) Retention of the Gram-negative bacterium SW8 on surfaces under conditions relevant to the subsurface environment: effects of conditioning films and substratum nature. *FEMS Microbiol Ecol* 14:243–254
- Solomin GI (1985) Problem of combined toxicological and hygienic evaluation of polymer construction materials (in Russian) *Kosmicheskaya Biologiya i Aviakosmicheskaya Medistina* 19:4–11
- Somlev V, Tishkov S (1994) Anaerobic corrosion and bacterial sulfate reduction: application for the purification of industrial wastewater. *Geomicrobiology* 12:53–60
- Sonne-Hansen J, Mathrani IM, Ahring BK (1993) Xylanolytic anaerobic thermophiles from Icelandic hot-springs. *Appl Microbiol Biotechnol* 38:537–541
- Srinivasan R, Stewart PS, Griebel T, Chen C-I (1995) Biofilm parameters influencing biocide efficacy. *Biotechnol Bioeng* 46:553–560
- Staley JT, Bryant MP, Pfennig N, Holt JG (1989) *Bergey's manual of systematic bacteriology*. Williams and Wilkins, Baltimore, <http://www.cme.msu.edu/bergeys>
- Starkey RL (1986) Anaerobic corrosion — perspectives about causes. In: Dexter SC (eds) *Biologically induced corrosion: proceedings of the international conference on biologically induced corrosion*. National Association of Corrosion Engineers, Houston TX, pp 3–7
- Stenbüchel A (1991) Polyhydroxyalkanoic acids. In: Byrom D (ed) *Biomaterials: novel materials from biological sources*. Macmillan, New York, pp 127–213
- Stern RV, Howard GT (2000) The polyester polyurethanase gene (pue A) from *Pseudomonas chlororaphis* encodes a lipase. *FEMS Microbiol Lett* 185:163–168
- Sternberg D, Vigayakumar P, Reese ET (1977) β -glucosidase: microbial production and effect on enzymatic hydrolysis of cellulose. *Can J Microbiol* 23:139–147
- Stewart PS (1996) Theoretical aspects of antibiotic diffusion into microbial biofilms. *Antimicrob Agents Chemother* 40:2517–2522
- Stewart PS, Hamilton MA, Goldstein BR, Schneider BT (1996) Modeling biocide action against biofilms. *Biotechnol Bioeng* 49:445–455
- Stolz JF, Oremland RS (1999) Bacterial respiration of arsenic and selenium. *FEMS Microbiol Rev* 23:615–627
- Stoodley P, DeBeer D, Lappin-Scott HM (1997) Influence of electric fields and pH on biofilm structure as related to the bioelectric effect. *Antimicrob Agents Chemother* 41:1876–1879
- Stranger-Joannesen M, Sorheim R, Zanotti D, Bichi A (1993) The ESA-LPTO simulation campaigns: microbial contamination of the closed manned habitats. 44th congress of the international astronomical confederation congress, IAF/IAA-93-G.4.162 Graz Austria

- Stroes-Gascoyne S, Pedersen K, Dumas S, Hamon CJ, Haveman SA, Delaney TL, Ekendahl S, Jahromi N, Arlinger J, Hallbeck L, Dekeyser K (1996) Microbial analysis of the buffer/container experiment at AECL's Underground Research Laboratory Whiteshell Laboratories, Atomic Energy of Canada Ltd Pinawa Manitoba, Canada AECL-11436, pp 1–219
- Stuart ES, Lenz RW, Fuller RC (1995) The ordered macromolecular surface of polyster inclusion bodies in *Pseudomonas oleovorans*. *Can J Microbiol* 41(Suppl):84–93
- Stumm W, Morgan JJ (1996) Oxidation and reduction, equilibria and microbial mediation. In: Stumm W, Morgan JJ (eds) *Aquatic chemistry: chemical equilibria and rates in natural waters*, 3rd edn. Wiley, New York, pp 425–515
- Suci PA, Vranj JD, Mittelamn MW (1998) Investigation of interactions between antimicrobial agents and bacterial biofilms using attenuated total reflection Fourier transform infrared spectroscopy. *Biomaterials* 19:327–339
- Sugio T, Hirayama K, Inagaki K, Tanaka H, Tano T (1992) Molybdenum oxidation by *Thiobacillus ferrooxidans*. *Appl Environ Microbiol* 58:1768–1771
- Sugio T, Tsujita Y, Katagiri T, Inagaki K, Tano T (1988) Reduction of Mo⁶⁺ with elemental sulfur by *Thiobacillus ferrooxidans*. *J Bacteriol* 170:5956–5959
- Sullivan BK, Oviatt CA, Klein-MacPhee G (1993) Fate and effects of a starch-based biodegradable plastic substitute in the marine environment. In: Kaplan D, Thomas E, Ching C (eds) *Fundamentals of biodegradable materials and packaging*. Technomic, Lancaster, pp 281–296
- Sunesson A, Vaes WHJ, Nilsson C, Blomouist G, Andersson B, Carlson R (1995) Identification of volatile metabolites from five fungal species cultivated on two media. *Appl Environ Microbiol* 61:2911–2918
- Swift MJ, Heal OW, Anderson JM (1979) Decomposer organisms. *Decomposition in terrestrial ecosystems: studies in ecology*, vol 5. Blackwell Scientific, London, pp 66–117
- Szycher M (1989) Medical-grade polyurethanes: their crucial role in artificial hearts. In: Hanker JS, Giammara BL (eds) *Biomedical materials and devices materials*, vol 110. Research Society, Pittsburgh, pp 41–50
- Tall BD, Williams HN, George KS, Gray RT, Walch M (1995) Bacterial succession within a biofilm in water supply lines of dental air-water syringes. *Can J Microbiol* 41:647–654
- Tanio T, Fukui T, Saito T, Tomita K, Kaiho T, Masamune S (1982) An extracellular poly(β -hydroxybutyrate) depolymerase from *Alcaligenes faecalis*. *Eur J Biochem* 124:71–77
- Tatnall RE (1986) Experimental methods in biocorrosion. In: Dexter SC (ed) *Biologically induced corrosion: proceedings of the international conference on biologically induced corrosion*. National Association of Corrosion Engineers, Houston TX, pp 246–253
- Taylor S, May E (1991) The seasonality of heterotrophic bacteria on sandstones of ancient monuments. *Int Biodeter* 28:49–64
- Taylor S, May E (1994) Detection of specific bacteria on stone using an enzyme-linked immunosorbent assay. *Int Biodeter Biodegr* 33:155–167
- Tebo BM, Obraztsova AY (1998) Sulfate-reducing bacterium grows with Cr(VI), U(VI), Mn(IV) and Fe(III) as electron acceptors. *FEMS Microbiol Lett* 162:193–198
- Thorp KEG, Crasto AS, Gu JD, Mitchell R (1994) Biodegradation of composite materials. In: Naguy T (ed) *Proceedings of the tri-service conference on corrosion*. US Government Printing House, Washington, DC, pp 303–314
- Thorp KEG, Crasto AS, Gu JD, Mitchell R (1997) Contribution of microorganisms to corrosion. National Association of Corrosion Engineers, Houston TX Corrosion
- Tiano P (1993) Biodeterioration of stone monuments: a critical review. In: Garg KL, Garg N, Mukerji KG (eds) *Recent advances in biodeterioration and biodegradation*. Naya Prokash, Calcutta, pp 301–321
- Tiano P, Accolla P, Tomaselli L (1995) Phototrophic biodeteriogens on lithoid surfaces: an ecological study. *Microb Ecol* 29:299–309
- Tilstra L, Johnsonbaugh D (1993) A test method to determine rapidly if polymers are biodegradable. *J Environ Polym Degr* 1:247–255
- Tomaselli L, Lamenti G, Bosco M, Tiano P (2000) Biodiversity of photosynthetic micro-organisms dwelling on stone monuments. *Int Biodeter Biodegr* 46:251–258
- Tomei FA, Maki JS, Mitchell R (1985) Interactions in syntrophic associations of endospore-forming, butyrate-degrading bacteria and H₂-consuming bacteria. *Appl Environ Microbiol* 50:1244–1250
- Torre MAD, Gómez-Alarcón G, Melgarejo P, Lorenzo J (1991) Fungal colonization of the Salamanca cathedral sandstones: some patterns of degradation. In: Baer NS, Sabbioni C, Sors AI (eds) *Science, technology and european cultural heritage*. Butterworth-Heinemann, Oxford, UK, pp 511–514
- Torre MAD, Gómez-Alarcón G, Palacios JM (1993a) 'In vitro' biofilm formation by *Penicillium frequentans* strains on sandstone, granite, and limestone. *Appl Microbiol Biotechnol* 40:408–415
- Torre MADL, Gómez-Alarcón G, Vizcaino G, Garcia MT (1993b) Biochemical mechanisms of stone alteration carried out by filamentous fungi living in monuments. *Biogeochemistry* 19:129–147
- Torres-Sanchez R, Magana-Vazquez A, Sanchez-Yanez JM, Gomez LM (1997) High temperature microbial corrosion in the condenser of a geothermal electric power unit. *Mat Perf* 36:43–46
- Törönen A, Kubicek CP, Henrissat B (1993) Amino acid sequence similarities between low molecular weight endo-1,4- β -xylanases and family H cellulases revealed by clustering analysis. *FEBS Lett* 321:135–139
- Tsao R, Anderson TA, Coats JR (1993) The influence of soil macroinvertebrates on primary biodegradation of starch-containing polyethylene films. *J Environ Polym Degr* 1:301–306
- Uhlig HH (1971) *Corrosion and corrosion control*. Wiley, New York
- Uhlig HH, Revie RW (1985) *Corrosion and corrosion control: an introduction to corrosion science and engineering*, 3rd edn. Wiley, New York
- Urzi C, Realini M (1998) Colour changes of Noto's calcareous sandstone as related to its colonization by microorganisms. *Int Biodeter Biodegr* 42:45–54
- Vaidya RU, Butt DP, Hersman LE, Zurek AK (1997) Effect of microbiologically influenced corrosion on the tensile stress-strain response of aluminum and alumina-particle reinforced aluminum composite. *Corrosion* 53:136–141
- Vandevivere P, Kirchman DL (1993) Attachment stimulates exopolysaccharide synthesis by a bacterium. *Appl Environ Microbiol* 59:3280–3286
- Vandevivere P (1995) Bacterial clogging of porous media: a new modelling approach. *Bifouling* 8:281–291
- van Loosdrecht MCM, Lyklema J, Norde W, Schraa G, Zehnder AJB (1987) The role of bacterial cell wall hydrophobicity in adhesion. *Appl Environ Microbiol* 53:1893–1897
- van Loosdrecht MCM, Lyklema J, Norde W, Schraa G, Zehnder AJB (1990) Influence of interfaces on microbial activity. *Microbiol Rev* 54:75–87
- van Westing EPM, Ferrari GM, De Witt JHW (1994) The determination of coating performance with impedance measurements. II: water uptake of coatings. *Corrosion Sci* 36:957–977
- Verbicky JW (1988) Polyimides. In: *Encyclopedia of polymer science and engineering*, vol 12. Wiley, New York, pp 364–383
- Verbiest T, Burland DM, Jurich MC, Lee VY, Miller RD, Volksen W (1995) Exceptionally thermally stable polyimides for second-order nonlinear optical applications. *Science* 268:1604–1606
- Videla HA (1996) Corrosion inhibition by bacteria. In: Videla HA, Fred Wilkes J, Silva RA (eds) *Manual of biocorrosion*. CRC Press, Boca Raton, pp 121–136
- Viktorov AN, Novikova ND (1985) Distinctions in formation of microflora on construction materials used in habitable pressurized compartments (in Russian) *Kosmicheskaya Biologiya i Aviakosmicheskaya Meditsina* 19:66–69
- Viktorov AN, Ilyin VK (1992) The actual problems of microbiological control in regenerative life support systems exploration. 43rd congress of the international astronomical confederation congress, IAF/IAA-92-0277, Washington, DC
- Viktorov AN, Ilyin VK, Syniak J (1993) The problems of microbial safety in regenerative life support systems exploration. 44th congress of the international astronomical confederation congress, IAF/IAA-93-G.4.161 Graz Austria
- Viktorov AN (1994) The characteristics of interaction between normal and conventionally pathogenic human microflora in different types of closed objects. 45th Congress of the International Astronautical Confederation Congress, IAF/IAA-94-5.165 Jerusalem Israel
- von Wolzogen Kuhr CAH, van der Vlugt IS (1934) The graphitization of cast iron as an electrochemical process in anaerobic soils. *Water (The Hague)* 18:147–165
- Wächtershäuser G (1988) Before enzymes and templates: theory of surface metabolism. *Microbiol Rev* 52:452–484

- Wagner PA, Ray RI (1994) Surface analytical techniques for microbiologically influenced corrosion—a review. In: Kearns JR, Little BJ (eds) Microbiologically influenced corrosion testing. American Society for Testing and Materials, Philadelphia PA, ASTM STP 1232, pp 153–169
- Wagner P (1995) Microbial degradation of stressed fiber reinforced polymeric composites. NACE International, Houston TX Corrosion
- Wagner P, Ray R, Hart K, Little B (1996) Microbiological degradation of stressed fiber-reinforced polymeric composites. *Mat Perf* 35:79–82
- Wakefield RD (1997) Masonry biocides: assessments of efficacy and effects on stone. *Scottish Soc Conserv Restor* 5–11
- Walch M, Mitchell R (1986) Microbial influence on hydrogen uptake by metals. In: Dexter SC (eds) Biologically induced corrosion: proceedings of the international conference on biologically induced corrosion. National Association of Corrosion Engineers, Houston TX, pp 201–209
- Walch M, Ford TE, Mitchell R (1989) Influence of hydrogen-producing bacteria on hydrogen uptake by steel. *Corrosion* 45:705–709
- Walch M (1992) Corrosion, microbial. In: Lederberg J (ed) Encyclopedia of microbiology, vol 1. Academic, San Diego, pp 585–591
- Wang P-C, Mori T, Komori K, Sasatsu M, Toda K, Ohtake H (1989) Isolation and characterization of an Enterobacter cloacae strain that reduces hexavalent chromium under anaerobic conditions. *Appl Environ Microbiol* 55:1665–1669
- Wang C-C, Fan S-J, Wang SJ, Zhang MG (1991) Research on powdery corrosion of the serials bells from Cai Hou Tomb. *Sci China (Ser B)* 34:522–529
- Wang C-C, Wu Y-S, Fan C-Z, Wang SJ, Hua YM (1993) Formation mechanism of particulates in the surface layer of Bronze Mirror Chinese. *Sci Bull* 38:429–432
- Wang J-S (1996) Hydrogen induced embrittlement and the effect of the mobility of hydrogen atoms. In: Thompson AW, Moody NR (eds) Hydrogen effects in materials the minerals, metals and materials. Society, Warrendale PA, pp 61–75
- Warcheid T, Oelting M, Krumbein WE (1991) Physico-chemical aspects of biodeterioration processes on rocks with special regard to organic pollutants. *Int Biodeter* 28:37–48
- Weimer PL, van Kavelaar MJ, Michel CB, Ng TK (1988) Effect of phosphate on the corrosion of carbon steel and on the composition of corrosion products in two-stage continuous cultures of *Desulfovibrio desulfuricans*. *Appl Environ Microbiol* 54:386–396
- Westlake DWS, Semple KM, Obuekwe CO (1986) Corrosion by ferric iron-reducing bacteria isolated from oil production systems. In: Dexter SC (ed) Biologically induced corrosion: proceedings of the international conference on biologically induced corrosion. National Association of Corrosion Engineers, Houston TX, pp 193–200
- White DC, Nivens DE, Geesey GG, Clarke CK (1986) Role of aerobic bacteria and their extracellular polymers in the facilitation of corrosion: use of Fourier transforming infrared spectroscopy and 'signature' phospholipid fatty acid analysis. In: Dexter SC (ed) Biologically induced corrosion. Proceedings of the international conference on biologically induced corrosion. National Association of Corrosion Engineers, Houston, pp 233–243
- Whitfield C (1988) Bacterial extracellular polysaccharides. *Can J Microbiol* 34:415–420
- Widdel F (1988) Microbiology and ecology of sulfate- and sulfite-reducing bacteria. In: Zehnder AJB (ed) Biology of anaerobic microorganisms. Wiley, New York, pp 469–585
- Widdel F (1992) Microbial corrosion. In: Finn RF, Prave P, Schlingmann M, Crueger W, Esser K, Thauer R, Wagner F (eds) Biotechnology focus, vol 3. Hanser, Munich, pp 261–300
- Wiencek KM, Fletcher M (1995) Bacterial adhesion to hydroxyl- and methyl-terminated alkanethiol self-assembled monolayer. *J Bacteriol* 177:1959–1966
- Wilkinson JF, Stark GH (1956) The synthesis of polysaccharide by washed suspensions of *Klebsiella aerogenes*. *Proc Roy Phys Soc Edinburgh* 25:35–39
- Williams ST, Sharpe ME, Holt JG (1989) Bergey's manual of systematic bacteriology. Williams and Wilkins, Baltimore, <http://www.cme.msu.edu/bergeys>
- Williams V, Fletcher M (1996) *Pseudomonas fluorescens* adhesion and transport through porous media are affected by lipopolysaccharide composition. *Appl Environ Microbiol* 62:100–104
- Williamson PR (1994) The screening of sponge extracts for antifouling activity using a bioassay with laboratory-reared cyprid larvae of the barnacle *Balanus amphitrite*. *Int Biodeter Biodegr* 34:361–373
- Williamson PR, Wakamatsu K, Ito S (1998) Melanin biosynthesis in *Cryptococcus neoformans*. *J Bacteriol* 180:1570–1572
- Wimpenny JWT, Colasanti R (1997) A unifying hypothesis for the structure of microbial biofilm based on cellular automaton models. *FEMS Microbiol Ecol* 22:1–6
- Wirsen CO, Jannasch HW (1993) Microbial degradation of a starch-based biopolymer in the marine environment. In: Kaplan D, Thomas E, Ching C (eds) Fundamentals of biodegradable materials and packaging. Technomic, Lancaster, pp 297–310
- Woese CR, Olsen GJ (1986) Archaeobacterial phylogeny: perspectives on the Urkingdoms System. *Appl Microbiol* 7:161–177
- Woese CR (1987) Microbial evolution. *Microbiol Rev* 51:221–171
- Woese CR (1990) Towards a natural system of organisms: proposal for the domains Archaea, Bacteria and Eukarya. *Proc Natl Acad Sci USA* 87:4576–4579
- Woese CR (1998) Default taxonomy: Ernest Mayr's view of the microbial world. *Proc Natl Acad Sci USA* 95:11043–11046
- Wolfaardt GM, Lawrence JR, Robarts RD, Caldwell SJ, Caldwell DE (1994) Multicellular organization in a degradative biofilm community. *Appl Environ Microbiol* 60:434–446
- Wong KKY, Tan LUL, Saddler JN (1988) Multiplicity of β -1,4-xylanase in microorganisms: function and applications. *Microbiol Rev* 52:305–317
- Wu Y-S, Wang C-S, Fan C-Z, Wang S-J, Li Z-C (1992) A study on corrosion-resistance mechanism of the ancient mirror 'Hei Qi Gu'. *Acta Phys Sinica* 41:170–176
- Xu X, Stewart PS, Chen X (1996) Transport limitation of chlorine disinfection of *Pseudomonas aeruginosa* entrapped in alginate beads. *Biotechnol Bioeng* 49:93–100
- Yao Y, Li Y (1995) Research and development of concrete admixtures. *Chinese J Mat Res* 9(Suppl):381–390
- Yoshizako F, Nishimura A, Chubachi M (1992) Microbial reduction of cyclohexanone by *Chlorella pyrenoidosa*. *Chick J Ferment Bioeng* 74:395–397
- Young GH (1948) Anti-fouling measures. In: Uhlig HH (ed) The corrosion handbook. Wiley, New York, pp 441–446
- Young LL, Cerniglia CE (1995) Microbial transformation and degradation of toxic organic chemicals. Wiley-Liss, New York
- Yu FP, McFeters GA (1994) Physiological responses of bacteria in biofilms to disinfection. *Appl Environ Microbiol* 60:2462–2466
- Yue S, Pilliar RM, Weatherly GC (1984) The fatigue strength of porous-coated Ti-6%Al-4%V implant alloy. *J Biomed Mat Res* 18:1043–1058
- Zachary A, Taylor ME, Scott FE, Colwell RR (1980) Marine microbial colonization on material surfaces. In: Oxley TA, Becker G, Allsopp D (eds) Biodeterioration: proceedings of the 4th international biodeterioration symposium. Pitman, London, pp 171–177
- Zaloguyev SN (1985) Results of microbiological studies conducted during operation of Salyut-6 orbital space station (in Russian) *Kosmicheskaya Biologiya i Aviakosmicheskaya Medistina* 19:64–66
- Zavarzin GA, Zhilina TN, Pusheva MA (1994) Halophilic acetogenic bacteria. In: Drake HL (ed) Acetogenesis. Chapman and Hall, New York, pp 432–444
- Zehnder AJB, Stumm W (1988) Geochemistry and biochemistry of anaerobic habitats. In: Zehnder AJB (ed) Biology of anaerobic microorganisms. Wiley, New York, pp 1–38
- Zhou Z, Brown N (1995) Slow crack growth in polyethylene gas pipes and resins. *Chinese J Mat Res* 9(Suppl):463–472
- Zinder SH (1993) Physiological ecology of methanogens. In: Ferry JG (ed) Methanogenesis: ecology, physiology, biochemistry and genetics. Chapman and Hall, New York, pp 128–206
- Zuo J, Xu C, Liu X, Wang C (1994) Study of the Raman spectrum of nanometer SnO₂. *J Appl Phys* 75:1835–1836
- Zyska B (1996) Performance of paper in Polish books of the period 1900–1994. *Restaurator* 17:214–228

13 Microbial Biofilms

Dirk De Beer¹ · Paul Stoodley²

¹Max-Planck-Institute for Marine, Microbiology, Bremen, Germany

²Imaging Center for Genomic Sciences, Allegheny-Singer Research Institute, West Penn Allegheny Health System, Pittsburgh, PA, USA

Introduction	343
Biofilm Structure	345
Heterogeneity	345
Extracellular Polymeric Substances (EPS)	347
Morphogenetic Factors	350
Hydrodynamics	350
Biofilm Viscoelasticity	351
Growth and Detachment	353
Cell-Cell Signaling	353
Mass Transfer and Microbial Activity	354
Mass Transfer in Biofilms	354
Stratification (E-Donor) and Internal Cycling	357
Special Physiology of Biofilm Cells?	358
Microbial Populations	359
Biofilm Control	360
Methods for Studying Biofilms	360
Cultivation	360
Laboratory-Scale Cultivation	360
Flow Cells	361
Annular Biofilm Reactor	361
Fowler Cell	361
The Modified Robbins Device (MRD)	361
Constant-Depth Fermenter	361
Reactors for Biofilms on Carriers	362
Microscopic and Staining Methods	362
Microscopy	362
Staining	362
Microbial Activity	363
Microsensors	363
Interpretation of Profiles	364

Population Analysis	365
Cultivation Techniques: Microslicing, Most Probable Number (MPN) Technique, and Plate Counting	365
Molecular Techniques	366

Introduction

Biofilms are usually thought of as the slimy layer of microorganisms that covers solid surfaces. However, there are a number of features that distinguish biofilm populations from their planktonic (suspended or free floating) counterparts, namely, the association with a surface, high population densities (on the order of 10^{10} cells per ml of hydrated biofilm), an extracellular polymer (EPS) slime matrix, and a wide range of physical, metabolic, and chemical heterogeneities. However, some biofilms may not have all features. Indeed, a concise universal definition of biofilms has yet to emerge; in part, this is because of the wide diversity of biofilm populations. Although much of contemporary microbiology is based on the study of planktonic “cells,” it is now thought that biofilms are the primary habitat for many microorganisms. Microbial mats associated with sediment and suspended microbial flocs or aggregates, although different in appearance from conventional biofilms, have many important features in common and thus are included in the definition of “biofilm.” Often biofilm cells are embedded within a highly hydrated EPS matrix, and in the absence of corrosion products or scale, biofilms are estimated to be primarily water. The physical properties of the biofilm are largely determined by the EPS, while the physiological properties are determined by the bacterial cells (► [Figs. 13.1](#) and ► [13.2](#)).

Characklis (1990a) identified up to eight processes in the development of biofilms. These can be condensed to three main processes: the attachment of cells to a surface (colonization), growth of the attached cells into a mature biofilm, and the detachment of single cells (erosion) or large pieces (sloughing) (► [Figs. 13.3](#) and ► [13.4](#)).

Since free convection is hindered within biofilms, the chemical environment to which the cells are exposed differs from the surrounding water phase. Also, mass transfer to the cells often limits conversion rates. All natural biofilms, mats, aggregates, and flocs can consist of complex microbial communities, and their function is characterized by interactions

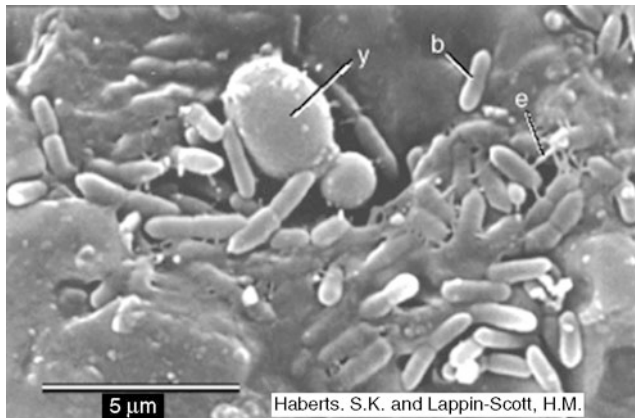

Fig. 13.1

Scanning electron photomicrograph showing biofilm formation after 24-h growth on stainless steel AISI 321. The biofilm was established under laminar pipe flow ($Re = 2.72$) using a modified Robbins device (MRD). The inocula were all environmental isolates and consisted of four Gram-negative rod-shaped bacteria, *Stenotrophomonas maltophilia*, *Pseudomonas alcaligenes*, *Alcaligenes denitrificans*, and *Flavobacterium indologenes*; one nonfermentative yeast, *Rhodotorula glutinis*; and two filamentous fungi, *Fusarium solani* and *Fusarium oxysporum* (Eivers 1998). The image shows a budding yeast cell “y” and bacterial rods “b” attached to the surface. The bacteria are embedded in an EPS matrix. During preparation for SEM the dehydrated EPS has formed characteristic strands “e.” Scale bar = 5 μm (Image supplied by Sara K. Roberts, Biological Sciences, Exeter University)

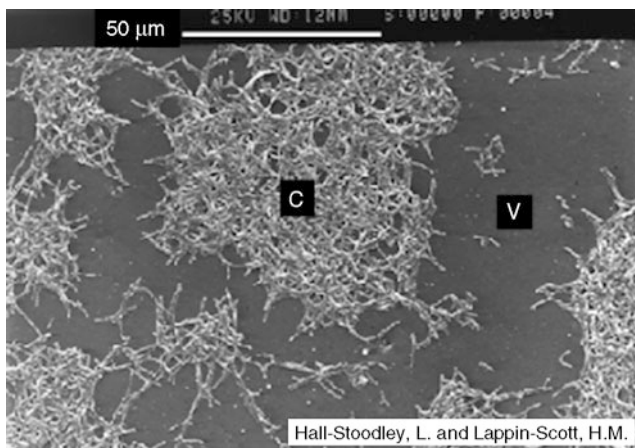

Fig. 13.2

Scanning electron photomicrograph showing biofilm formation of *Mycobacterium fortuitum* after 24-h growth on silicone rubber (Hall-Stoodley 1998). The biofilm was grown under laminar flow in a MRD. The biofilm was composed of cell clusters “c” surrounded by voids “v.” Scale bar = 50 μm (Image supplied by Luanne Hall-Stoodley, Biological Sciences, Exeter University)

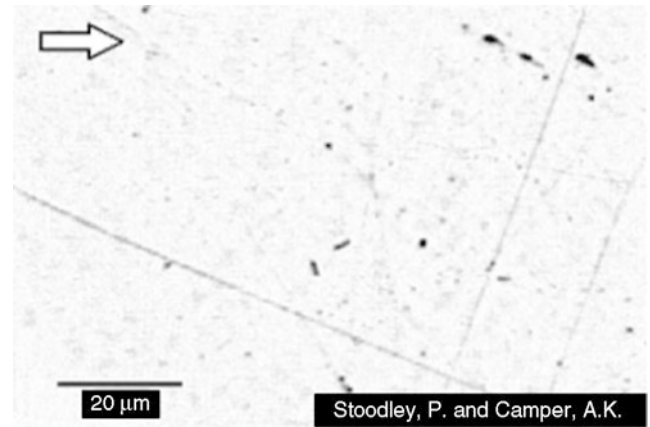

Fig. 13.3

Time-lapse movie showing the initial events of biofilm formation. *Pseudomonas aeruginosa* cells are attaching to a 316L stainless steel coupon over 6.5 h. The *P. aeruginosa* cells were initially grown in a chemostat with a residence time of 5 h. The stainless steel coupon was mounted in a flat-plate flow cell and the inoculum was delivered with an average flow velocity of 2.8 $\text{cm}\cdot\text{s}^{-1}$ ($Re = 6$). Note how some of the cells divide, detach, and move around on the surface. Arrow indicates flow direction. Scale bar = 20 μm (Images were enhanced for clarity using NIH-Image 1.59 (available at <http://zippy.nimh.nih.gov>). For Fig. 13.3, see the online version of *The Prokaryotes*)

between different populations within these communities. Many experimental methods to study aggregated biomass are similar, that is, microscopic and staining techniques. We will refer therefore in this review to all types of aggregated microorganisms. Table 13.1 gives some examples of biofilm types.

Biofilms, flocs, and microbial mats are responsible for most microbial conversions in natural environments. Natural biofilms can develop on solid surfaces under all conditions facilitating microbial growth; thus, biofilms are ubiquitous in nature, covering rocks and plants in seawater and freshwater, sediment grains, and sediment surfaces. Microbial mats are formed on most sediments, especially under extreme conditions (temperature, salinity) that inhibit the activity of grazers (Karsten and Kühl 1996). Flocs are highly fragile structures suspended in fresh- and seawater (called river and marine snow) and typically occur during bloom periods after an increased input of nutrients. Consequently, biofilms exist almost everywhere, and microbial aggregates are responsible for the majority of the microbial conversions in many aquatic ecosystems. Biofilms have been associated with a wide range of problems both in industry and in medicine (Table 13.2) and have been utilized for various processes (Table 13.3).

Microbial cells living in biofilms are much more difficult to eradicate or control than suspended cells. Yet the susceptibility of biofilm cells to antibiotics and industrial antimicrobial agents is rarely assessed. In part, this is due to convention and, in part, because standard testing protocols against suspended cultures

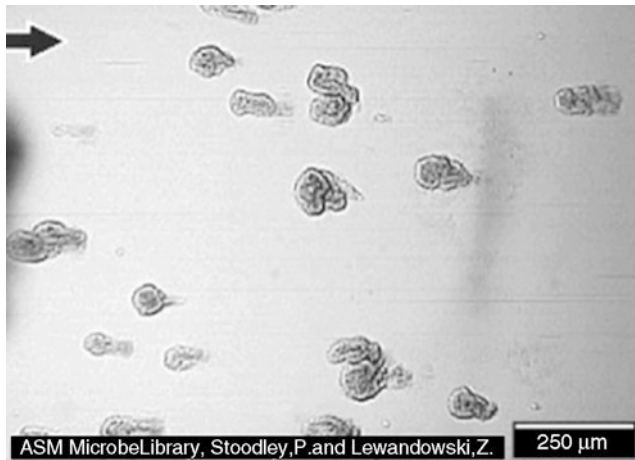

■ Fig. 13.4

Time-lapse movie showing the accumulation of a bacterial biofilm on a glass surface over 14 days. The biofilm was composed of *Pseudomonas aeruginosa*, *Pseudomonas fluorescens*, and *Klebsiella pneumoniae* and was grown in a glass flow cell (average flow velocity = $1.8 \text{ m}\cdot\text{s}^{-1}$) to simulate conditions in an industrial pipeline. Note the complex structure of biofilm patches (dark) and water channels between them. After 12 days, much of the biofilm detached from the surface in a “sloughing event.” There was a corresponding decrease in pressure drop across the flow cell, which had been building up as the biofilm accumulated (Lewandowski and Stoodley 1995). The arrow shows the direction of fluid flow. Scale bar = $250 \mu\text{m}$. This sequence of images has been accepted for use in the ASM Biofilms Collection [<http://www.asmsa.org/edusr>]]. For  Fig. 13.4, see the online version of *The Prokaryotes*

are much easier to develop. Cell density and growth phase can be easily controlled in both batch and chemostat cultures, whereas biofilms are highly variable.

Currently, the most important practical use of biofilms is for biological wastewater treatment, while many emerging technologies are utilizing biofilms for biodegradation and bioremediation in bioreactors. Municipal wastewater is treated in activated sludge plants that are based on the activity of flocs. Their relevance in natural element cycles as well as their economical and medical impact has been recognized, and the study of immobilized cell systems has gained considerable momentum in the last decade. The knowledge has been advanced because of new techniques to determine the functioning, structure, and microbial populations in biofilms.



Biofilms and microbial mats are thus important microbial communities in most aquatic ecosystems today. Interestingly, the first known fossils of single microbes and microbial communities share almost identical structural characteristics to those found in recent biofilms and microbial mats (Schopf and Klein 1992).

Because of their ubiquity in natural and industrial environments, the study of biofilms lends itself to a multidisciplinary approach involving microbiology and engineering. Originally, an engineering approach was used to study biofilm performance

on the macroscale (i.e., for optimization of wastewater treatment plants). Subsequently, engineering concepts were applied to further our understanding of biofilm processes on the microscale. An important task for microbiologists studying biofilms is to determine the types of organisms present and to determine their in situ activities. This chapter will focus on recent findings on biofilm structure, mass-transfer phenomena, microbial activities, and community structure. Brief descriptions of biofilm cultivation methods and new techniques to determine biofilm structure in situ, community structure and population distributions, and in situ microbial activity distributions will be given.

Biofilm Structure

Biofilm structure is the spatial arrangement of bacteria, cell clusters, EPS, and particulates. Since the structure can influence transport resistance, it is a significant determinant in the activity of the biofilm. Various conceptual and mathematical models have been proposed to describe the structure and function of biofilms (Characklis 1990a; Rittmann and Manem 1992; Wanner and Gujer 1986). Mathematical models describing transport, conversion, cell growth, and biofilm development are based on conceptual models. Biofilms were initially considered as planar structures, impermeable and with homogeneous cell distribution. Mass transfer through the mass boundary layer and within the biofilm was assumed to be diffusional and perpendicular to the surface to which it was attached (the substratum).

Biofilms and mats are matrices of cells and extracellular polymers (EPS). The EPS is produced by the cells and consists of polysaccharides, polyuronic acids, proteins, nucleic acids, and lipids (Schmidt and Ahring 1994; Decho 1990; Decho and Lopez 1993). EPS holds the cells together and to the substratum. Owing to the dimensions of microbial mats and biofilms, their structural analysis is strongly dependent on microscopic methods that are briefly discussed and listed in  Table 13.4 ( Fig. 13.5).

Heterogeneity

Recent microscopic observations indicated that biofilms are not flat and the distribution of microorganisms is not uniform. Instead, multispecies biofilms were observed with complex structures containing “voids,” channels, cavities, pores, and filaments and with cells arranged in clusters or layers. Such complex structures were found in a wide variety of biofilms such as methanogenic films from fixed-bed reactors (Robinson et al. 1984), aerobic films from wastewater plants (Eighmy et al. 1983; Mack et al. 1975), nitrifying biofilms (Kugaprasatham et al. 1992), and pure culture biofilms of *Vibrio parahaemolyticus* (Lawrence et al. 1991) and *Pseudomonas aeruginosa* (Stewart et al. 1993).

Depending on growth conditions and age, the thickness of biofilms can range from a few micrometers (a monolayer) up to

■ Table 13.1

Examples of different types of biofilms

Environment	Biofilm type	Thickness (m)	Community	References
Natural	Photosynthetic microbial mats, hot springs, and hypersaline lakes	10^{-3} to 1	Mixed algal and bacterial community	Stal (1994)
	Stromatolites	1	Bacterial	Stal (1994)
	Benthic/river sediments	10^{-6} to 10^{-3}	Mixed bacterial, algal, and protozoan communities	Baty (1996) Costerton (1994)
Medical	Dental plaque	10^{-6} to 10^{-4}	Mixed bacterial community	Kinnement (1996)
	Infectious	10^{-6} to 10^{-3}	Often bacterial or fungal monocultures	Morck (1994) Buret (1991)
Industrial	Heat exchangers	10^{-6} to 10^{-3}	Mixed bacterial and fungal communities	Characklis (1990)
	Drinking water pipes	10^{-6} to 10^{-2}	Mixed bacterial and fungal communities	Camper (1994) Van Der Kooij (1994)
	Wastewater treatment	10^{-4} to 10^{-3}	Mixed bacterial and fungal communities, biofilms, aggregates, and flocs	Lemmers and Griebel (1995)
	Filtration units	10^{-5} to 10^{-4}	Mixed bacterial and fungal biofilms	Flemming (1996)
	Ship hulls	10^{-4} to 10^{-2}	Mixed bacterial and algal and marine macroorganisms	Cooksey (1995)

■ Table 13.2

Problems associated with biofilms

Problems	Consequences
Fouling of heat exchangers	Loss of heat exchange efficiency and reduction of flow capacity
Fouling of ships	Energy losses
Oil reservoirs	H ₂ S souring by sulfate-reducing bacteria
Industrial and drinking water pipelines	Energy losses, pitting and general corrosion, product contamination, pathogen reservoirs
Dental plaque	Dental caries
Medical infections	Colonization of indwelling devices (catheters, artificial joints, contact lenses) – endocarditis

a centimeter. Owing to the microscopic dimensions of microbial mats and biofilms, their structural analysis strongly depends on the microscopic methods used. Most microscopic techniques involve preparation of the sample, such as dehydration and embedding, which causes the soft biofilm structure to collapse and often to be observed as flattened (Stewart et al. 1995). Because this structure most conveniently agreed with the basic assumption for one-dimensional (1-D) modeling, it was

■ Table 13.3

Processes which utilize biofilms

Processes	Uses
Wastewater treatment	Bioremoval of pollutants
Biobarriers ^a	Immobilization of groundwater contaminants; microbially enhanced oilfield recovery (MEOR)
Metals leaching	Enhanced recovery of metals

^aSee MacLeod 1988

accepted as the general structure of biofilms. However, a study by Siebel and Characklis (1990) using interference contrast (Nomarsky) microscopy challenged this assumption. They reported that binary population biofilms of *Pseudomonas aeruginosa* and *Klebsiella pneumoniae* could form uneven biofilms consisting of patchy clusters of cells surrounded by a smooth monolayer. After the introduction of confocal scanning laser microscopy (CSLM), however, the perception changed drastically. The findings with new microscopic techniques indicate that the assumptions for 1-D geometry need to be carefully analyzed. CSLM images of undisturbed biofilms show that biofilms can consist of biomass clusters separated by interstitial voids (De Beer et al. 1994). [Voids were made visible with a negative staining by fluorescein that is strongly quenched

■ Table 13.4

List of microscopic techniques for studying biofilms and mats

Microscopy technique	Spatial resolution	Application	Sample treatment	References
LM	1 μm	EPS and cells	Dehydration, freezing, sectioning, staining	Chayen (1973)
FM	1 μm	EPS and cells	Dehydration, freezing, sectioning, staining	Stewart (1995), Griebe (1995), De Beer (1996)
SEM	1 nm	Cell and EPS surfaces	Dehydration, sputter coating	Beeftink (1986), Paterson (1995)
ESEM	10 nm	Cell and EPS surfaces	None	Little (1991)
TEM	1 nm	Cells and EPS	Dehydration, sectioning, staining	Beeftink (1986), Bakke (1984), Sanford (1995)
CSLM	1 μm	EPS, cells, voids	Staining	Lawrence (1991), De Beer (1994)
AFM	0.1 μm	Cell and EPS surfaces	None	Bremer (1992), Gunning (1996)

Abbreviations: *LM* light microscopy, *EPS* extracellular polymer slime, *FM* fluorescence microscopy, *SEM* scanning electron microscopy, *ESEM* environmental scanning electron microscopy, *TEM* transmission electron microscopy, *CSLM* confocal scanning laser microscopy, *AFM* atomic force microscopy

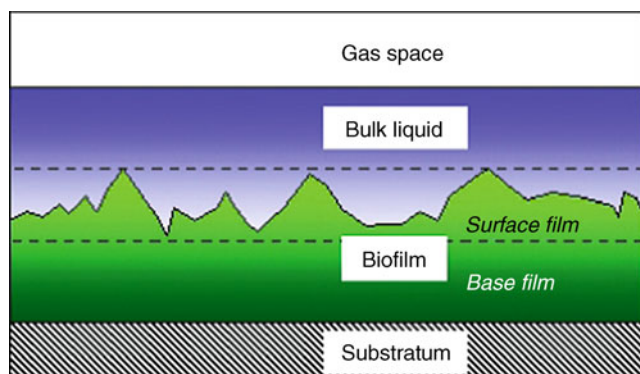

■ Fig. 13.5

Conceptual model for biofilm structure proposed at the 1988 Dahlem conference (Wilderer 1989). The model divides the biofilm system into specific compartments: the substratum, the biofilm, the bulk liquid, and a possible headspace. The biofilm compartment was further subdivided into a base film and a surface film. Although the model recognized a certain degree of biofilm roughness, it was essentially a planar layered model

by biomass. Cells (stained with a DNA stain) and EPS (stained with calcofluor and Alcian blue) were observed in the clusters, while no cells or EPS could be detected in the voids.] Fluorescent beads (0.3 μm) added to the medium immediately penetrated the voids but not the cell clusters. It was concluded that voids were water channels in open connection with the bulk water phase. Fluid flow in the biofilm was later directly demonstrated and quantified, by using the beads as particle tracers to visualize flow through the water channels (Stoodley et al. 1994). The flow velocity of individual beads at various depths in the biofilm

channels were calculated by measuring the bead track length, using confocal microscopy. The resulting flow profiles were consequently used to determine the fluid shear stress acting on the channel wall and the surface of the biofilm cell clusters (deBeer et al. 1994; Stoodley et al. 1994). These observations were made on biofilms grown in the lab, either as undefined culture or as mixed pure culture. Similar observations were reported from both pure culture biofilms and biofilms with undefined microbial communities from various sources (Massol-Deya et al. 1995; Gjaltema et al. 1994; Zhang 1994; Neu and Lawrence 1997; Okabe et al. 1996; Okabe et al. 1997). The presence of voids has considerable consequences for mass transfer inside the biofilms (advection) and exchange of substrates and products with the water phase (effective exchange surface), as will be discussed in the relevant section. These new findings have led to a concept that incorporates two key features: structural heterogeneity and the water flow within the biofilm (● Figs. 13.6–13.11).

Extracellular Polymeric Substances (EPS)

The proportion of EPS can vary between 50 % and 80 % of the organic matter and is the main structural component of biofilms. The physical properties of the biofilm are largely determined by the EPS, while the physiological properties are determined by the bacterial cells. A common perception was that EPS consists mainly of polysaccharides, and many detection techniques focus on this group of compounds (Christensen and Characklis 1990; Neu and Lawrence 1997; Beeftink and Staugaard 1986; Williams and Wimpenny 1978; De Beer 1996). Also, research relating EPS to biofilm functioning, cell-cell and cell-surface interactions was concentrated on the polysaccharide

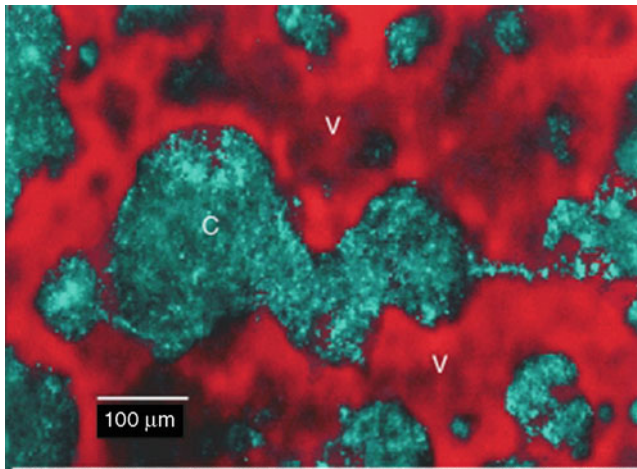

Fig. 13.6

Biofilm composed of *P. aeruginosa*, *P. fluorescens*, and *K. pneumoniae* grown in a glass flow cell for 5 days (de Beer et al. 1994a). The image was taken using CSLM which allows high resolution 3-D imaging of fully hydrated samples. Differential staining with propidium iodide (a nucleic acid stain) and fluorescein (red) showed that the biofilm consisted of cell clusters “c” separated by interstitial voids “v” or water channels. Scale bar = 100 μm (Image available from the ASM Biofilms Collection [<http://www.asmta.org/edusrc/edu34.htm>])

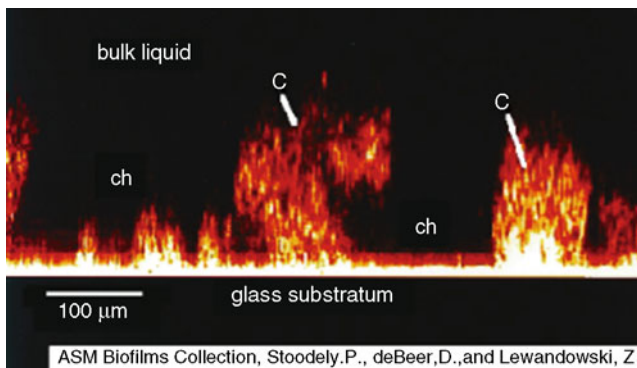

Fig. 13.7

Side view of the same biofilm in Fig. 13.6. Cells appear red and orange and are grouped in distinct cell clusters “c” separated by water channels “ch.” Some of the cell clusters formed “mushroom” shapes, which greatly increase the available surface area for nutrient and waste product exchange with the bulk liquid. The horizontal white line is the glass surface. Scale bar = 100 μm (Image available from the ASM Biofilms Collection [<http://www.asmta.org/edusrc/edu34.htm>])

fraction of EPS. However, recent analyses showed that biofilms contain EPS consisting of a mixture of protein, polysaccharides, lipids, and nucleic acids (Nielsen et al. 1997; Schmidt and Ahring 1994; Jahn 1995; Frolund et al. 1996). Protein appeared the most abundant EPS component (50 % or more) in activated

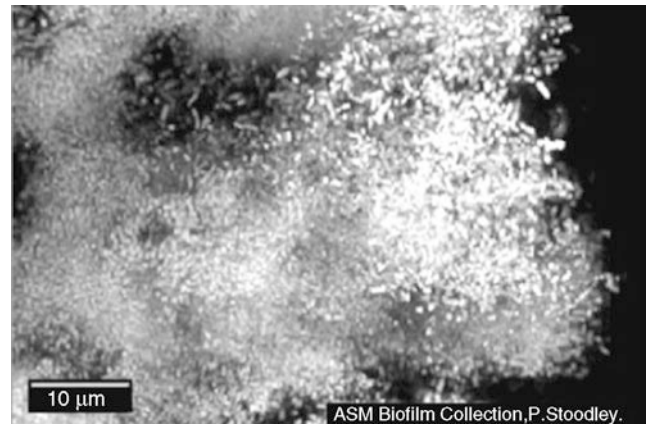
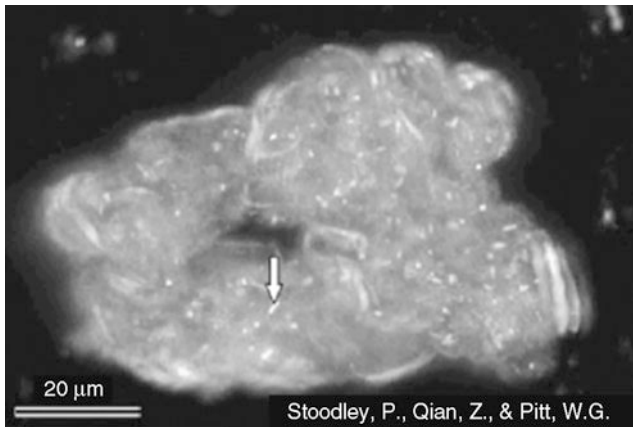

Fig. 13.8

Movie sequence showing 3-D structure of a mixed-species biofilm taken by CSLM. The biofilm was composed of *Pseudomonas aeruginosa*, *Pseudomonas fluorescens*, and *Klebsiella pneumoniae* and was grown in a flow cell with an average liquid flow velocity of $6.6 \text{ cm} \cdot \text{s}^{-1}$. The biofilm was heterogeneous and was made up of microbial cell clusters (individual cells are stained with propidium iodide and appear as bright dots) held in an EPS matrix (not stained in this image). The biofilm was approximately 150-μm thick and protrudes out toward the viewer. The image is composed of 27 overlaid optical sections taken at 6-μm depth intervals. The motion is an artifact used to give the 3-D effect. Scale bar = 10 μm. For Fig. 13.8, see the online version of *The Prokaryotes*

sludge (Frolund et al. 1996), biofilms (Jahn and Nielsen 1995), and anaerobic aggregates (Ahring et al. 1993), while polysaccharides were much less abundant (5–20 %). Detailed knowledge is available on the polysaccharide content of both laboratory grown and natural biofilm EPS (Sutherland 1994, 1996); however, data on the actual composition of nonpurified biofilm EPS as it occurs in situ are lacking. Thus, we face the situation that the actual composition of EPS, including the protein fraction, is largely unknown, as are its chemical and physical properties. Since EPS is the second important fraction of biofilms, beside cells, research on the chemistry and properties of EPS has a high priority.

More research on the composition and function of EPS is needed, since EPS has been linked with many processes and properties integral to biofilm behavior, that is, attachment, detachment, mechanical strength, antibiotic resistance, and exo-enzymatic degradation activity. The mechanical stability of a biofilm is important for stable process maintenance (sloughing of biofilms, floc stability). To remove unwanted biofilms, surfactants are used to weaken the strength of the matrix. Furthermore, there is evidence that biofilms maintain their structural heterogeneity by releasing EPS-degrading enzymes (Davies et al. 1998). This interesting process is thought to involve cell-cell communication, that is, quorum sensing, through the generation of homoserine lactones (Greenberg 1997).



■ Fig. 13.9
Movie sequence showing 3-D structure of a pure-culture *Pseudomonas aeruginosa* biofilm taken by CSLM (Qian et al. 1996). The biofilm was heterogeneous and consisted of cell clusters and surrounding water channels. This image shows a donut-shaped cell cluster that protrudes out toward the viewer. The bright dots are stained bacterial cells (representative cell indicated by arrow) and the lighter, hazy material is probably EPS slime. The biofilm was grown in a polycarbonate flow cell on a glass slide. Scale bar = 20 μm . For Fig. 13.9, see the online version of *The Prokaryotes*

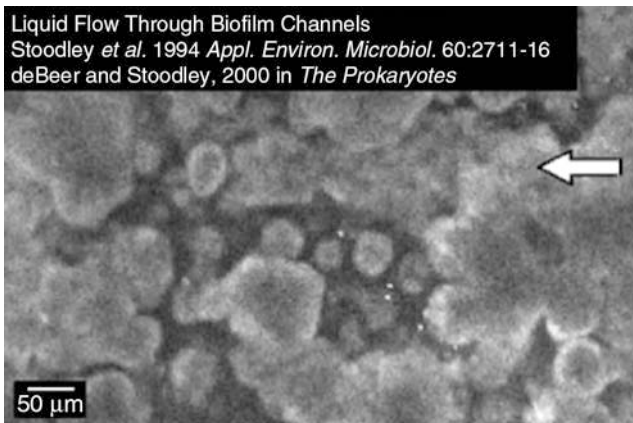

■ Fig. 13.10
Time-lapse CSLM movie sequence showing fluorescent latex beads moving through biofilm water channels (Stoodley et al. 1994). The bacterial biofilm, composed of *Pseudomonas aeruginosa*, *Pseudomonas fluorescens*, and *Klebsiella pneumoniae*, was grown in a flow cell on a glass coverslip. The sequence of images was taken over 44 s. The beads were moving with a velocity of approximately $15 \mu\text{m}\cdot\text{s}^{-1}$; the average liquid flow velocity of the bulk liquid was $6.6 \text{ cm}\cdot\text{s}^{-1}$. The arrow indicates flow direction of the bulk liquid. Note that in some cases, the flow around the cell clusters is counter to that of the channel current. The biofilm clusters were autofluorescent and appear lighter than the surrounding water channels. The optical section was taken at a depth of $70 \mu\text{m}$ in the $175\text{-}\mu\text{m}$ thick biofilm. Scale bar = $50 \mu\text{m}$. For Fig. 13.10, see the online version of *The Prokaryotes*

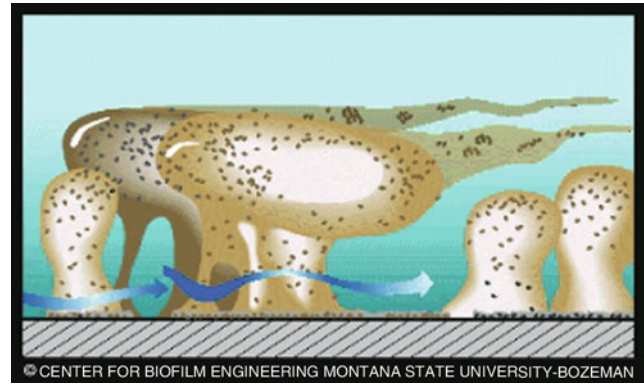

■ Fig. 13.11
Recent “Center for Biofilm Engineering” conceptual biofilm model incorporating structural complexity and liquid flow through biofilm channels. The model also incorporates biofilm streamers, which form as a function of fluid shear. The schematic was composed by Peg Dirckx of the Center for Biofilm Engineering (With permission from the Center for Biofilm Engineering, Bozeman, Montana, USA)

Binding of water is important for dehydrating activated sludge (Nielsen et al. 1996). Pollutants may bind considerably to the EPS of biofilms; 60 % of biofilm-bound BTX, but less than 20 % of the biofilm-bound heavy metals (Späth et al. 1998), was located in the EPS.

EPS can mask the original surface properties of the cells and render hydrophobic surfaces hydrophilic. The phenomenon of flotation of anaerobic aggregates occurs by attachment of gas bubbles to the hydrophobic aggregate surface. Aggregates with low amounts of EPS showed a strong tendency to float, leading to severe biomass losses from the reactors. The presence of carbohydrates in the feed increases the amount of EPS, especially on the aggregate surface, inhibiting attachment of gas bubbles and preventing flotation (De Beer 1996; Neu and Lawrence 1997).

The diffusion coefficient of solutes in biofilms is influenced by the microstructure of EPS (Neu and Lawrence 1997; De Beer et al. 1997). Biofilms have been considered to be highly porous polymer gels (Christensen and Characklis 1990) and diffusion studies demonstrate their gel-like characteristics (De Beer et al. 1997). Also, recent *in situ* rheological testing of *P. aeruginosa* biofilms, grown in the absence of divalent cations, showed that the biofilm behaved like a non-cross-linked polymer gel (Stoodley et al. 1999c). In this case, the EPS matrix can be considered to be a two-phase system with a solid network of polymers and free interstitial water as depicted by Stewart (1998). Only then does the structure of the network effect diffusivity (Westrin 1991), particularly when the pore size of the network is of the same order of magnitude as the molecular diameter of the solute. Based on this assumption, it is possible to infer some properties of the microstructure of EPS from the diffusional behavior of large molecules. It was found that the diffusion of small molecules is not strongly inhibited by the

biofilm matrix, whereas diffusion of large molecules is impeded (Bryers and Drummond 1996). Similar effects of the molecular size were found using microinjection of fluorescent dyes (fluorescein, MW 332, $\text{\AA} > 1$ nm, diffusivity not affected, and phycoerythrin, MW 240,000, $\text{\AA} = 11$ nm, 40 % reduction of diffusivity; De Beer et al. 1997). The pore size of the biofilm matrix (ca. 80 nm) was calculated from these data.

However, it has been reported that the forces keeping the polymers together are not strong covalent bonds, but weak hydrophobic and electrostatic interactions and hydrogen bonds (Flemming 1998). These forces are weakened by surface active agents, complexing agents, pH and ionic strength. Flemming concluded that a significant portion of the EPS may not be in bound form; if so, the polymers would increase the viscosity and reduce the diffusion coefficient, which could explain in part contradictory findings on D_{eff} . Boyd and Chakrabarty (1994) hypothesized that altering the length of polymer chains through the activity of alginate lyase may control the viscosity of *P. aeruginosa* biofilms. It is clear that further research is needed on both the physical and chemical properties of EPS, which appears to play a critical role in the structure and function of biofilms.

Morphogenetic Factors

In conclusion, the architectural features of biofilms can be viewed in terms of a hierarchical arrangement, the basic components of the biofilm being the cells and the EPS. These can combine to form secondary structures such as discrete cell clusters (which may take on various forms and dimensions) and a base film. Finally, the arrangement of base film, cell clusters, and the void areas between the clusters gives the overall biofilm architecture. The relative importance of each of these features in determining the biofilm heterogeneity can be highly variable.

Hydrodynamics

Hydrodynamic conditions control two interdependent parameters (mass transfer and shear stress) and will, therefore, significantly influence many of the processes involved in biofilm development. Two types of flows are relevant to most natural and industrial processes: laminar flow and turbulent flow. Generally, when the flow rate of a liquid is low, flow will be laminar, and when the rate is high, it will be turbulent. Transition between these two types of flow will be dependent on channel geometry and fluid properties and, in many cases, can be predicted by the Reynolds number (Re), a dimensionless parameter commonly used by engineers (Vogel 1994). In closed pipes, flow is generally turbulent at a Re above 1,200. The Re is also useful as a comparative indicator of flow conditions in a diverse range of systems. Briefly, in laminar flow shear stresses are low and mixing is poor, whereas in turbulent flow shear stresses are high and mixing is good. Under these conditions, shear and mixing have opposing influences on biofilm accumulation and on the resulting biofilm structure (van Loosdrecht

et al. 1995). Increased shear tends to increase the detachment rate by the physical removal of individual cells (erosion) or larger pieces of biofilm (sloughing), while increased mixing tends to increase the growth rate by reducing transport limitations and increasing the nutrient supply. The rate of transport of dissolved and particulate species (nutrients, biocides, etc.) into the biofilm and the removal of waste products from the biofilm also will have a profound influence on the chemistry (pH and eH, etc.) of the local microenvironment. It has been hypothesized that there may be an optimal flow for biofilm formation below which accumulation would be limited by mass transfer and above which accumulation would be limited by detachment (Lewandowski 1991).

To date, most of the detailed investigation on biofilm structure has been conducted on biofilms grown in the laboratory under laminar flows. These biofilms tend to be cell clusters which are roughly circular or amorphous and in which there is no obvious axial alignment. However, in turbulent flows, the influence of drag becomes apparent, and biofilms form filamentous “streamers” which can oscillate rapidly in the flow (Bryers and Characklis 1981; McCoy et al. 1981; Siegrist and Gujer 1985; Stoodley et al. 1998, 1999a, b). The increased energy losses in pipelines have been attributed to the possible formation of streamers (Picologlou et al. 1980). More recently, it has been shown that mixed biofilms growing in turbulent flow can form ripple structures that steadily migrate downstream (Stoodley et al. 1999d). The ripple morphology and migration velocity varied with bulk liquid flow velocity, with a response time on the order of minutes. The ripples had a maximum migration velocity of approximately $1 \text{ mm}\cdot\text{h}^{-1}$. Dalton et al. (1996) have observed cyclical colonization by marine *Vibrio* and *Pseudomonas* species growing in laminar flow, in which microcolonies repeatedly formed and dispersed over periods between 1 and 2 days. However, in this case, it appears that the structural changes were caused by gliding motility of the individual cells, possibly in response to nutrient conditions in the biofilm. It is generally assumed that microcolonies (also termed cell clusters) are formed mainly through cell division during the early stages of biofilm formation. The observation by Dalton et al. (1996) reveals that clusters also can form by the grouping together of attached cells. Both of these observations (Dalton et al. 1996; Stoodley et al. 1999d) demonstrate that the structural arrangement of biofilms is not only spatially but also temporally complex.

Influence of hydrodynamics on the structure of a *Pseudomonas aeruginosa* PAO1 biofilms grown in parallel glass flow cells under laminar and turbulent pipe flow (Stoodley et al. 1999b). The biofilms were grown on a minimal salts medium with glucose ($400 \text{ mg}\cdot\text{l}^{-1}$) as the carbon source. Images were taken 7 days after inoculation. Black arrow indicates direction of bulk liquid flow. Scale bar = $50 \mu\text{m}$ (● Figs. 13.12–13.14).

It may be possible to predict biofilm morphotypes from theoretical consideration of the relative influences of mass transfer and shear (Stoodley et al. 1999a). At high shear flows, where the influence of drag is high but mass-transfer limitations are low, drag-reducing planar structures may be expected. In low

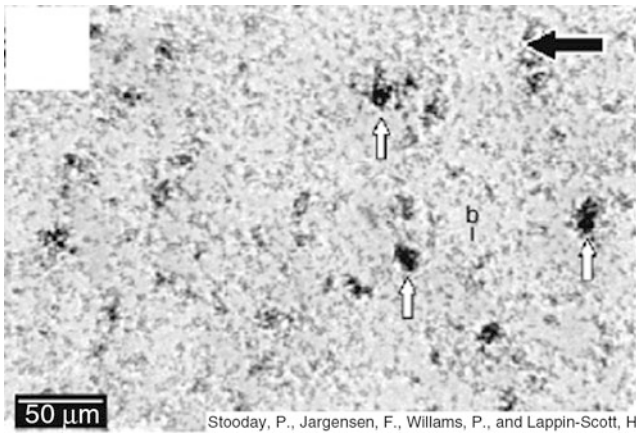

■ Fig. 13.12

The biofilm grown under laminar flow (flow velocity = $0.033 \text{ m}\cdot\text{s}^{-1}$, $Re = 120$) was composed of small cell clusters (white arrows) with single cells "b" in the void spaces

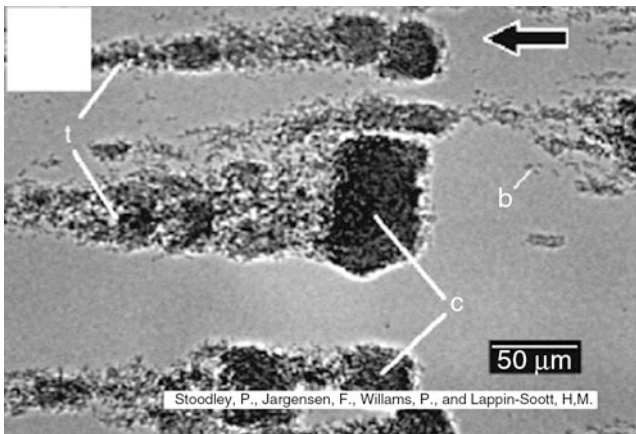

■ Fig. 13.13

The biofilm grown under turbulent flow (flow velocity = $1.0 \text{ m}\cdot\text{s}^{-1}$, $Re = 3,600$) was composed of larger clusters which had become elongated in the downstream direction to form tapered streamers. Each streamer consisted of an upstream "head" cell cluster "c," which was attached to the glass surface, and a downstream tail "t." Some of the tails were free to oscillate in the flow, while others were more firmly attached to the substratum. The void spaces between the streamers were almost devoid of single cells "b"

shear flows, where the mass-transfer limitations are high but drag is low, highly porous structures with high surface exchange areas might be expected. Intermediate forms may exist between these extreme conditions.

Biofilm Viscoelasticity

In addition to the long-term influence of hydrodynamics on the structure of biofilms grown under steady shear, biofilm structure

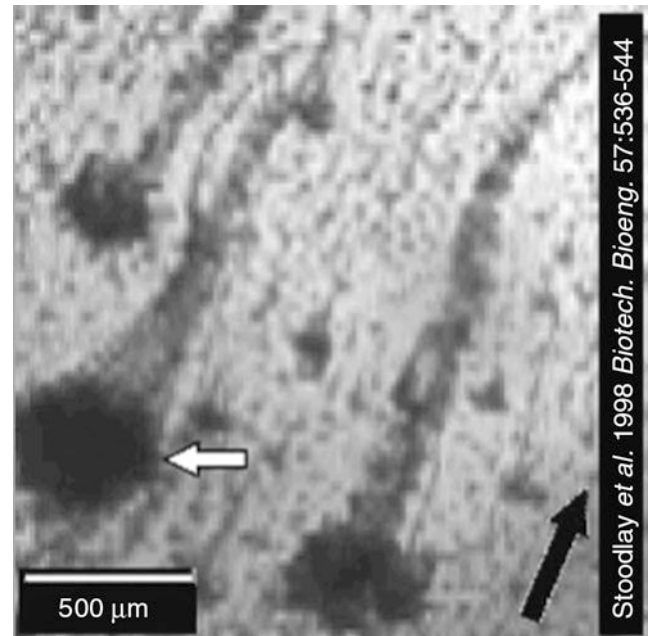

■ Fig. 13.14

Time lapse movie showing biofilm streamers oscillating in turbulent flow. The bacterial biofilm, composed of *Pseudomonas aeruginosa*, *Pseudomonas fluorescens*, and *Klebsiella pneumoniae*, was grown on a glass observation window in a polycarbonate flow cell. The oscillation frequency of the streamers was directly proportional to the velocity of bulk liquid, suggesting that the oscillations were caused by vortex shedding of the upstream "head" (white arrow) of the streamer (Stoodley et al. 1998). Black arrow indicates flow direction; scale bar = $500 \mu\text{m}$. For ▶ Fig. 13.14, see the online version of *The Prokaryotes*

also can be influenced by short-term changes in fluid shear. Structural changes to mixed and pure culture biofilms caused by variations in fluid shear demonstrate that biofilms can be viscoelastic and have a very low elastic modulus (ca. 30 Pa, i.e., biofilms are highly compliant; Stoodley et al. 1999c). The biofilms exhibited liquid flow when the fluid shear stress exceeded the yield point. The yield point occurred between 1.2 and 2.0 times the shear at which the biofilm was grown. It is possible that liquid-like behavior may explain the formation of flowing ripples in similar biofilms (see ▶ Figs. 13.15 and ▶ 13.16).

Also the thickness of cell clusters was reduced by up to 30 % when the flow velocity was increased from 0 to $1.5 \text{ m}\cdot\text{s}^{-1}$. It is thought that the flexibility of certain seaweeds, anemones and other benthic macroorganisms may allow the organisms to withstand the large variations in drag to which they are subjected by wave action (Koehl 1984). In these types of organisms, drag reduction can be achieved when the organisms "collapse" into a more streamlined shape. It is possible that the flexibility of some biofilms is an adaptive characteristic, which allows these biofilms to remain attached when exposed to varying shears (as would be expected in turbulent flow and many natural flowing water systems).

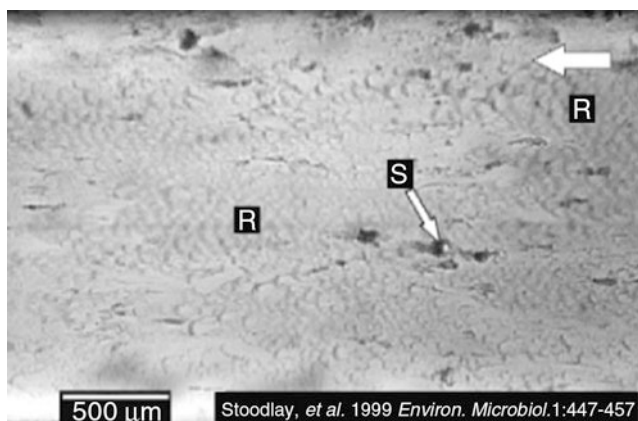

Fig. 13.15

Time-lapse movie showing the migration of biofilm *ripple-like* structures across a glass surface. The mixed species biofilm was composed of *Pseudomonas aeruginosa*, *Pseudomonas fluorescens*, *Stenotrophomonas maltophilia*, and *Klebsiella pneumoniae* (Stoodley et al. 1999d). *Ripple patches* are labeled “R.” Elongated streamers “S” also formed in the biofilm. The streamers did not migrate across the surface, but some of them were observed to detach during the observation period (see labeled streamer “S”). The biofilm was 15 days old and grown in turbulent pipe flow at a bulk liquid flow velocity of $1 \text{ m}\cdot\text{s}^{-1}$ ($Re = 3,600$). The flow direction is indicated by the *arrow*. Frames were captured at 1-h intervals over 15 h. Scale bar = $500 \mu\text{m}$. For Fig. 13.15, see the online version of *The Prokaryotes*

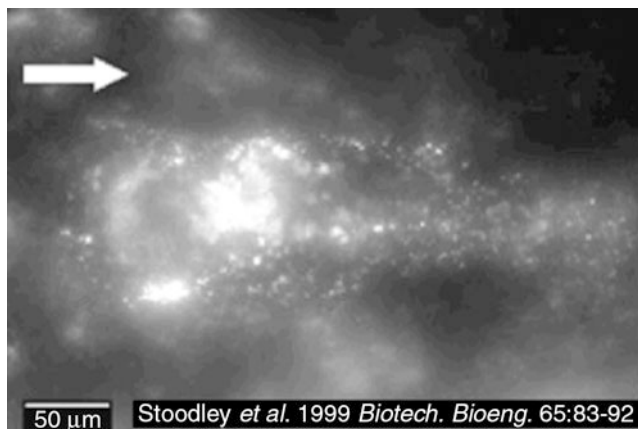

Fig. 13.16

Time-lapse movie showing the influence of fluid shear on biofilm structure (Stoodley et al. 1999c). The biofilm streamer was stained with fluorescent beads, which appear as *bright dots* and were used as fiducial points to monitor structural changes. The sequence of images shows the changes to structure as the fluid shear was increased stepwise from 0 to 10.11 Pa and then reduced stepwise back to 0. When the load was removed, the biofilm “sprang” back, clearly demonstrating an elastic response. Arrow indicates flow direction. Scale bar = $50 \mu\text{m}$. For Fig. 13.16, see the online version of *The Prokaryotes*

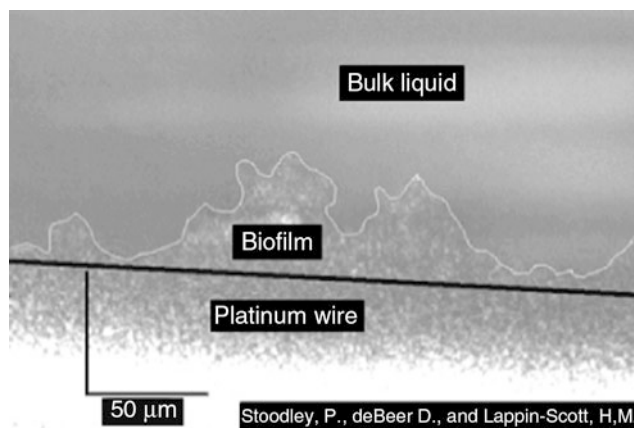

Fig. 13.17

Time-lapse movie sequence showing the expansion and contraction of a mixed-species biofilm growing on a platinum wire (Stoodley et al. 1997). The biofilm expanded when the wire was cathodic but contracted when it was anodic. The biofilm could fully expand and contract at a maximum frequency of approximately 5 Hz. At higher frequencies, the biofilm appeared to fibrillate. Similar contractions and expansions could be induced by pH alone. The edge of the wire is indicated by the *black line*. The edge of the biofilm has been outlined in *white* for clarity. Scale bar = $50 \mu\text{m}$. For Fig. 13.17, see the online version of *The Prokaryotes*

Biofilm rheology also may help explain the large energy losses that biofilms can cause in water pipelines. High-pressure drops (δP) have been linked to the observed formation of filamentous streamers, and it has been calculated that the measured δP was significantly greater than that expected from an equivalent rigid structure (Picologlou et al. 1980). It is known that rigid structures that are anchored in flowing fluids can dissipate the kinetic energy of the fluid through skin friction and pressure drag (Vogel 1994). Skin friction is dependent on surface area and is more significant in laminar flows. Pressure drag is shape-dependent and is more significant in turbulent flows. Biofilms that are behaving viscoelastically also can dissipate kinetic energy through both elastic and viscous action (Stoodley et al. 1999c). Rapid elastic deformations, which may occur when biofilm streamers oscillate, would result in the generation of heat in the biofilm matrix as bonds repeatedly stretch and contract. It is expected that, because of the thin nature of the biofilm, this heat would be quickly transferred to the bulk liquid. Viscous behavior also can generate heat through friction as individual polymer strands move past each other when biofilm flows. As yet, it is not clear what the relative contribution of each of these mechanisms is to the formation of pressure drops in pipe flow (Fig. 13.17).

In addition, biofilm structure may be influenced electrochemically. It has been found that electrical fields can cause biofilms to rapidly contract and expand (Stoodley et al. 1997). It was found that the thickness of a mixed species biofilm cluster was reduced to 74 % of the original thickness when the platinum wire which it had been grown on was cathodic. This

change was similar to that caused physically by hydrodynamic shear (see above). This effect is common in gels and may lead to increased exchange between water phase and biofilm and partly explain the bioelectric effect (Wellman 1996).

Growth and Detachment

Detailed studies on growth and detachment have been performed by van Loosdrecht and his group. Tjihuis et al. (1996) suggested that the degree of heterogeneity is determined by the balance between the growth rate and abrasion. Indeed, slow-growing organisms (e.g., nitrifiers and methanogens) form relatively flat biofilms or spherical aggregates; faster (heterotrophic) growth results in formation of more heterogeneous biofilms with cell clusters and streamers. Characklis (1990a) has demonstrated the relative contributions of nutrient loading and flow velocity on biofilm thickness. At low loading rates ($0.1 \text{ g carbon}\cdot\text{m}^{-2}\cdot\text{h}^{-1}$) biofilm thickness (ca. $50 \mu\text{m}$) was nutrient-limited and relatively independent of liquid flow velocity. However, at higher loading rates ($2.4 \text{ g carbon}\cdot\text{m}^{-2}\cdot\text{h}^{-1}$), the biofilm thickness was approximately $1,000 \mu\text{m}$ at a liquid flow velocity of $1.5 \text{ m}\cdot\text{s}^{-1}$ but was reduced to $200 \mu\text{m}$ when the biofilm was grown at a liquid flow velocity of $3 \text{ m}\cdot\text{s}^{-1}$. In this case, the biofilm thickness was presumably limited by shear-induced detachment as the flow rate was increased. It is well established that generally thinner biofilms form (and less biofilm biomass accumulates) under low nutrient conditions, and it has been proposed that biofilm accumulation may be limited by removing nutrients under controlled conditions in an upstream biofilter (Griebe and Flemming 1998). However, there is less information on the influence nutrients have on the structure of biofilms. Møller et al. (1997) reported that the structure of a mixed microbial community grown under laminar flow changed in response to a switch in substrate (while maintaining a constant labile carbon loading rate) (Møller et al. 1997). When grown on 2,4,6-trichlorobenzoic acid, the biofilm consisted of mounds of cells separated by void areas. However, when the substrate was switched to trypticase soy broth, the biofilm became thicker, and growth in the void areas resulted in a less heterogeneous structure. Also, a change in nutrient concentration can cause a change in the structure of an established biofilm as well as changes in thickness and surface coverage. Stoodley et al. (1999a) reported that the structure of a 21-day mixed-species biofilm growing in turbulent flow initially consisted of ripples and streamers (see [Fig. 13.15](#)) but changed to large cell clusters (ca. $500 \mu\text{m}$ in length) when the carbon and nitrogen concentration was increased by a factor of 10. The biofilm also significantly increased in thickness and surface coverage. When C and N concentrations were reduced to their original levels, there was a loss of biomass and the ripples and streamers reappeared. We speculate that cell surface properties, in particular hydrophobicity or hydrophilicity, also can determine the biofilm structure. Cell surface hydrophobicity results in minimization of the contact surface between liquid and biofilm and thus in planar biofilms or spherical aggregates. Hydrophilic cells

will more easily form protrusions like streamers and cell clusters. Typically, dividing cells (Allison et al. 1990) and many (facultative) aerobic heterotrophs (Daffonchio et al. 1995) are hydrophilic. Heterotrophic conditions thus result in heterogeneous biofilms. Examples of hydrophobic microorganisms are benthic cyanobacteria (Fattom and Shilo 1984), methanogens, syntrophic bacteria, and, to a lesser extent, sulfate reducers (Daffonchio et al. 1995). Indeed, cyanobacterial mats and methanogenic biofilms are usually relatively flat; however, detailed observations on mat structure and heterogeneity have not been conducted to the same extent as on bacterial biofilms.

Cell-Cell Signaling

Finally, cell-cell communication must be considered as a morphogenetic mechanism. By sensing cell-produced compounds, for example, *N*-acyl-homoserine lactones where the acyl group determines action or strain specificity, cells recognize the local cell density (therefore called “quorum sensing”) and react by switching on or off certain sets of functional genes. Quorum sensing regulates the expression of the lux genes in the bioluminescent bacterium *Vibrio fischeri* and the release of virulence genes in pathogens like *Pseudomonas aeruginosa*, and it plays a role in the symbiotic host association of *Rhizobium leguminosarum* in root nodules. Genes for quorum sensing have been found in ca. 25 different bacterial species, and this communication mechanism is believed to be common among Gram-negative bacteria (Greenberg 1997). Quorum sensing also determines the structure of *P. aeruginosa* biofilms (Davies, personal communication): the presence of *N*-3-oxododecanoyl-L-homoserine lactone enhances the production of polyuronic acids, which are important components of bacterial EPS. The lactone concentration is increased, due to restricted out-diffusion, at higher cell densities or after adhesion to a surface, thereby enhancing biofilm formation. At higher concentrations (as can occur in dense and thick biofilms), the same compound induces production of *N*-butyryl-L-homoserine lactone, which then induces the production of alginate lyase that can dissolve EPS and lead to rapid cell mobilization and formation of voids in the biofilm matrix. Mutants of *P. aeruginosa*, defective in quorum sensing, form flat and homogeneous biofilms, while the wild-type organism forms heterogeneous biofilms (Davies et al. 1998). If these mutants are grown with *N*-3-oxododecanoyl-L-homoserine lactone added to the medium, a patchy biofilm resembling the wild-type biofilm is formed. Two counteracting lactones, one stimulating cell aggregation (biofilm formation) and one stimulating biofilm dissolution, can thus regulate biofilm structure. Halogenated furanones, produced by marine algae, interfere with the cell-cell signaling mechanism, resulting in strongly decreased biofilm accumulation (Maximilien et al. 1998). It can be expected that the newly found mechanism of cell-cell signaling will be very important in future biofilm studies. This will lead to an explanation of many biofilm characteristics and to more ways to manipulate biofilms.

Mass Transfer and Microbial Activity

Substrates for biofilm growth usually are supplied by the water phase, and metabolic products are eventually released into the water phase. The rates of exchange between the biofilm and the water phase are determined by the mass-transfer processes of diffusion and advection. Microbial conversions in biofilms are, therefore, dependent and often limited by mass transfer. The process rates should be determined in situ. Activity determinations on biofilm samples cannot give reliable data as the microenvironment cannot be accurately replicated in vitro. Conversions are related mostly to cell growth and division, and the development of reliable methods to determine growth rates of single cells in situ has proved difficult. However, the combination of two photon confocal microscopy with fluorescent gene activity reporters should remove much of the ambiguity associated with current techniques.

Mass Transfer in Biofilms

A common property of microbial mats, biofilms, flocs, and aggregates is the occurrence of mass-transfer resistance. This is due to the limited water flow inside the matrix and the presence of a hydrodynamic boundary layer between the matrix and the surrounding water phase (Jørgensen and Revsbech 1985; Jørgensen 1994; Lewandowski et al. 1993; De Beer et al. 1993, 1994; De Beer and Stoodley 1995; Ploug and Jørgensen 1998). Transport of solutes is thought to be primarily by diffusion inside the biofilm matrix and in the boundary layer adjacent to the solid surface. Consequently, when the internal chemical composition (substrates and products) differs from bulk water conditions, steep gradients develop. This has strong effects on the type and rates of microbial conversions. Mass-transfer resistance often limits conversion rates. However, many processes can occur only inside biofilms because of special prevailing conditions. For example, anaerobic conversions like denitrification, sulfate reduction, and methanogenesis primarily take place in anoxic environments found in the deeper zones of biofilms and mats. However, recent studies showed that anaerobic processes also can occur in the oxic part of sediments and mats, indicating that anaerobic bacteria have special physiological adaptations or that anaerobic microniches may exist in the oxic zone (Canfield and Des Marais 1991; Frund and Cohen 1992; Krekeler et al. 1997). A characterization of the microenvironments and their interaction with mass-transfer processes is needed to understand conversions inside biofilms.

The simplest biofilm concept is a planar geometry, with microbial activity distributed homogeneously and all transport parameters constant regardless of depth. Adjacent to the biofilm is a mass boundary layer (MBL) in which the transport gradually changes from diffusional to advective in the mixed bulk liquid. This is illustrated in Fig. 13.18, showing an O₂ microprofile in and above a respiring biofilm. The strength of this concept is its simplicity, which facilitates mathematical modeling of

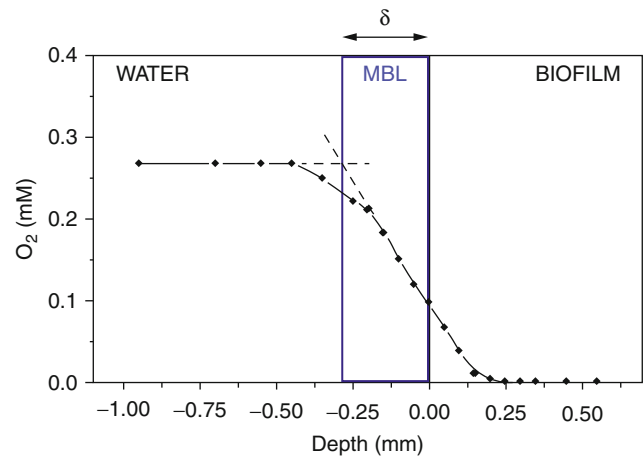

Fig. 13.18
Oxygen profile measured in a moderately active biofilm. The crosspoint of the dashed lines indicates the upper boundary of the hypothetical mass boundary layer (MBL), having a thickness δ . The image shows that a significant part of the mass-transfer resistance can be situated outside the biofilm

transport, conversion, and growth (Wanner and Gujer 1986; Rittmann and Manem 1992; Wanner and Reichert 1996) (Fig. 13.18).

The mass-transfer resistances can be separated into external, in the MBL, and internal, in the matrix itself. The resistance in the MBL is proportional to its thickness, which depends mainly on the flow velocity of the liquid (Jørgensen and Des Marais 1990). The mass transport coefficient, k_s , and the thickness of the MBL, δ , can be calculated from the liquid flow velocity (u). For example (Shaw and Hanratty 1977):

$$k_s = 0.0889u_\infty Sc^{-0.704} \quad (13.1)$$

with Sc as the Schmidt number,

$$Sc = \frac{\eta\rho}{D_{\text{eff}}} \quad (13.2)$$

with η as the dynamic viscosity, ρ as the density of the water phase, and

$$\delta = \frac{D_{\text{eff}}}{k_s} \quad (13.3)$$

Ultimately, the effective diffusion coefficient (D_{eff}) and the penetration depth (ρ ; diffusion distance) of the limiting substrate determine the mass-transfer resistance (η) in the matrix.

The relative importance of the MBL and intra-matrix resistance for conversion rates has been described for flat geometry with first- and zero-order kinetics (De Beer 1998). Qualitatively expressed, the greater is the microbial activity of the matrix, the smaller is the penetration depth of the limiting substrate. Consequently, the relative contribution of the mass-transfer resistance inside the matrix decreases. Therefore, the higher the microbial activity, the more important the MBL is for the regulation of microbial activity. The penetration depth of O₂, often the limiting substrate, is typically 100 μm in

active biofilms, while the thickness of the MBL is in the range of 50–300 μm . Consequently, external mass transfer, and thus flow velocity (see Eq.), often determines the activity of biofilms.

Internal mass transfer is usually considered to be diffusional and, consequently, frequently described using a single effective diffusion coefficient (D_{eff}). The flux of a compound, therefore, depends both on its diffusion coefficient and the slope of the concentration profile

$$J = D_{\text{eff}} = \frac{dc}{dx} \quad (13.4)$$

where J is the flux ($\text{mol}\cdot\text{m}^{-2}\cdot\text{s}^{-1}$), D_{eff} is the effective diffusion coefficient in the biofilm, and dc/dx is the concentration gradient.

Both diffusion and advection of solutes are important in biofilms. The biofilm matrix hinders both phenomena; obviously the matrix is an effective barrier not only for water movement (advection) but also for the random movement of solutes (diffusion). The effective diffusion coefficient (D_{eff}) is proportional to the biofilm porosity (θ) and inversely proportional to the square of the diffusional distance, the average path length (ϕ):

$$D_{\text{eff}} = \frac{D_w\theta}{\phi^2} \quad (13.5)$$

Diffusion is the only transport mechanism when there is no flow inside the biofilm, while advection usually becomes the dominant mechanism when the matrix is sufficiently permeable to allow liquid flow. Contrary to advective transport, diffusion becomes rapidly less effective with increasing distance. A simple

calculation example demonstrates this; the root-mean-square displacement (x) due to diffusion is described by Berg 1983:

$$\langle x^2 \rangle^{1/2} = \sqrt{2Dt} \quad (13.6)$$

where t = time.

From this equation, it is evident that displacement due to diffusion is time dependent: for a diffusion coefficient with a representative value of $1 \times 10^{-9} \text{ m}^2\cdot\text{s}^{-1}$, the average displacement due to diffusion is 100 μm in 5 s, 1 mm in 10 min, 1 cm in 14 h, and 1 dm in 2 months. Diffusion is a very effective transport process for short distances (the size of bacterial cells), but it is much slower over longer distances (the thickness of biofilms). Solute transport due to advection equals the velocity of the liquid, and even if it is in the order of $1 \mu\text{m}\cdot\text{s}^{-1}$, advection will be as important as diffusion for biofilms, which typically range from a few hundred μm to several mm thick. Microscopic observations have showed that biofilms can be highly porous, thus the common assumption that diffusion is the sole transport mechanism must be treated with care. Indeed, it was shown that water can flow between the cell clusters as described in the heterogeneity section. Fluorescent beads quickly penetrated the voids, and their movement, followed by confocal microscopy, showed that water can flow through the channel-like structures (De Beer 1994; Stoodley 1994, 1997). With oxygen microsensors, it was further demonstrated that the oxygen concentration inside the voids is much higher than that in the adjacent cell-clusters, and thus diffusion will occur in a horizontal direction or even from voids at the base of the biofilms in an upward direction into the cell clusters (Fig. 13.19; De Beer 1994). It was calculated that

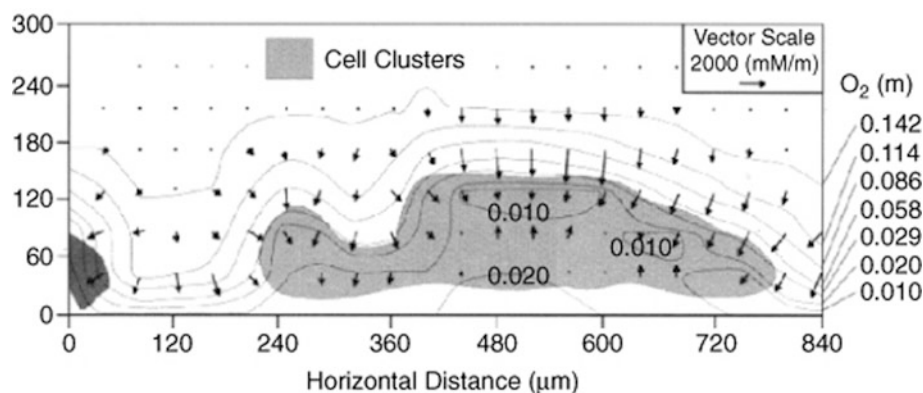

■ Fig. 13.19

Cross section through a heterogeneous biofilm showing dissolved oxygen (DO) contours associated with the cell clusters (shaded) and surrounding water channels. Twenty two adjacent DO profiles were measured by microelectrode to give a 2-D array of DO measurements. The microelectrode was guided by micromanipulator, and confocal microscopy was used to locate the positions of the clusters and channels. In this particular biofilm, the cell clusters were held away from the flow-cell wall (located toward the bottom of the figure) by “stalk-like” structures. Since this cross section did not intersect any of these stalks, the biofilm cluster appears to be “floating” above the wall of the flow cell. The arrows are the calculated DO fluxes and the length of the arrow is proportional to the magnitude of the flux. Note the penetration of DO into the biofilm channel which is centered at 120 μm on the x-axis. Also note that in the center of the large cell cluster the flux arrows are pointing upward, indicating that DO was being supplied from underneath the cell cluster. In this case, the anaerobic region occurred in the center of the cell cluster, approximately 100 μm away from the substratum, and not in a layer adjacent to the wall as would be predicted for a flat biofilm. The vertical distance in microns is shown on the left Y-axis

in such heterogeneous biofilms, the interfacial oxygen flux is two to three times higher than that for a flat biofilm. At low flow velocity, this effect disappears and a 1-D model can be applied (De Beer 1995). Upon injecting a fluorescent dye in the voids of a biofilm, an elongated plume developed, while injection inside the pores resulted in a spherical plume (De Beer 1995). Therefore, it was concluded that in voids flow occurs and induces advective transport at higher flow velocities, but in cell clusters diffusion is the only transport mechanism (● Fig. 13.19).

Numerous studies reporting measurements of the D_{eff} of various compounds in biofilms and microbial aggregates have been reviewed (Christensen and Characklis 1990; Libicki et al. 1988; Siegrist and Gujer 1985). Literature values show a wide range of variation, D_{eff} being 1–900 % of the diffusion coefficient in water (D_w), reflecting the variety of biofilms studied as well as the different measurement methods. The D_{eff}/D_w ratios for substrates with small molecular weights, such as oxygen, glucose, ammonium, and nitrate, in spontaneously growing biofilms and microbial aggregates are assumed to be around 0.9 (Christensen and Characklis 1990). Diffusion of macromolecules such as DNA, dextrans, and proteins may be more strongly impeded by biofilm matrices, resulting in decreased D_e/D_w ratios. Diffusion experiments with such molecules have been reported only for gel matrices; however, biofilms have been considered to be highly hydrated gels (Christensen and Characklis 1990). An extensive review on diffusion phenomena in gels is given by Westrin (1991). It has been shown that the D_e/D_w of proteins diffusing through agarose gels is inversely correlated with their molecular weight (Boyer and Hsu 1992; Arnold et al. 1985). This is due to gel-matrix polymers obstructing diffusion (Rodbard and Chranbach 1970) as well as to hydrodynamic drag at the matrix polymer-solvent interface (Brenner and Gaydos 1977). The impeded diffusion of large molecules in gels is strongly influenced by the microstructure of the gel matrices; consequently, information about the microstructure of the biofilm matrix may be derived from diffusion data.

Diffusivities in biofilms have been estimated by measuring transient or steady-state fluxes through biofilms in diffusion chambers or in uptake experiments (Libicki et al. 1988). If the experiments are performed with a nonreacting compound or with killed biofilms, D_{eff} can be calculated by fitting the measured fluxes with a diffusion model. In the case of a reacting compound, a reaction-diffusion model is necessary.

The determination of diffusivities by these methods assumes a homogeneous and flat biofilm. It was, however, shown that biofilms are not always flat but may contain streamers, cell clusters, voids, pores, and channels that may affect strongly the transport properties of the biofilm. Thus, the diffusivity may be overestimated from advective transport through the pores. This may explain why D_e higher than D_w values have been reported (Libicki et al. 1988; Siegrist and Gujer 1985).

To describe transport inside biofilms, transport in the voids (advection and diffusion) and in the base film and cell clusters (diffusion only) must be distinguished. For this, measuring

techniques with high spatial resolution are needed. A powerful technique for determining local diffusional properties of biofilms is the fluorescence recovery after photobleaching (FRAP) method (Axelrod et al. 1976). Application of optical techniques is limited to transparent structures. First, a biofilm is soaked with fluorescently labeled compounds. The FRAP method measures the diffusion of fluorescent molecules into a small area in which all molecules are bleached by a high-intensity laser beam. After that volume is depleted of fluorescent molecules by the laser flash, other molecules diffuse in from the surrounding area. By quantitatively monitoring this diffusion using CSLM and by fitting these data using a mathematical model, the diffusion coefficient of the compound can be calculated. The spatial resolution of the method is ca. 30 μm . It was found that the diffusion of small molecules (MW 300) was not significantly impeded by biomass. Large molecules, such as dextrans, proteins, and DNA, were impeded (ca. 30 % of that in water for large proteins, MW 200,000, and 20 % for DNA, MW 3×10^6 ; Bryers and Drummond 1996).

A conceptually related technique is based on microinjection of a fluorescent tracer and on monitoring the expansion of the fluorescent plume by CSLM (De Beer et al. 1997). Instead of diffusion into a depleted area (FRAP), the out-diffusion is followed into the surrounding area. The distribution pattern of the dye is fitted with an implicit equation to obtain a local value for D , the diffusion coefficient. A refinement of this technique is to detect the fluorescence with an optical fiber connected to the microinjection capillary (De Beer et al. 1997; Kühl and Revsbech 1998). This microsensor can be used in thick nontransparent biofilms. With this technique, similar observations were obtained as with FRAP: the diffusion coefficient of small molecules (MW 300) is close to that in water, while the mobility of large molecules (MW 240,000) is decreased to ca. 30 %.

Both FRAP and microinjection are non-steady-state methods of measuring the diffusivity at a particular location in the biofilm. The value obtained is the molecular diffusivity, corrected for the tortuosity of the matrix (D_w) but not the porosity (Libicki et al. 1988). For determination of D_{eff} (D_w/j), flux measurements during steady-state transport are needed.

Recently, two microsensor approaches were developed to determine local diffusivity (D_{eff}) with high spatial resolution. A microsensor method to determine local diffusivities or local mass-transfer properties (Yang and Lewandowski 1995; Rasmussen and Lewandowski 1998) is based on measuring the limiting current during the reduction of Fe^{3+} . A strong inhibition of Fe^{3+} transport was measured in biofilms, especially in deeper parts of the cell clusters, with values lower than 10 % of that in water. These findings contradict others that concluded small molecules are not impeded in their motility (Bryers and Drummond 1996; De Beer et al. 1997). Possibly, because of the measuring conditions employed (0.5 M KCl and 25 mM $\text{K}_3\text{Fe}(\text{CN})_6$), the viscosity in the biofilm was increased by cell lysis or weakening of the EPS bonds, thus decreasing the diffusivity. Recently, a diffusion microsensor was developed, based on out-diffusing of a tracer gas from

a needle-type capillary, with a tip size of 140 μm . The concentration of the tracer (H_2 or C_2H_2) in the tip of the capillary is measured using a normal microelectrode incorporated into the capillary. The signal is governed by the diffusional resistance in a sphere around the tip of the sensor and, thus, is proportional to the local diffusion coefficient (Revsbech et al. 1998). With this sensor, the D_{eff} in methanogenic aggregates was estimated at 50 % of that in water (Santegoeds 1999a).

In a recent study using NMR imaging, D_{eff} was determined in microbial mats, which were stratified; their diffusivity values ranged from 30 % to 60 % of that in water (Wieland 1999). These measurements were confirmed with the gas-diffusion sensor (Revsbech et al. 1998).

In conclusion, data on the diffusion coefficient in biofilms are highly variable. This may be partially due not only to differences in the techniques used but also to the possibility of large variations within individual biofilms and between different types of biofilms.

Stratification (E-Donor) and Internal Cycling

In sediments, a stratification into zones with different microbial conversions is well documented (Berner 1981). Sediments are subjected to a continuous or intermittent influx of organic matter, which is mineralized in several steps. Therefore, a wide diversity of conversions takes place, and as a consequence several profiles develop. The deeper regions are more anoxic and reduced than the top, which is usually aerobic. The organics are degraded and oxidized by bacteria using electron acceptors in the characteristic sequence O_2 , NO_3^- , MnO_2 , Fe^{3+} , SO_4^{2-} , and CO_2 (Reeburgh 1983). This sequence coincides with the standard free-energy changes of the reactions involved, and it is assumed that the larger the energy yield of a conversion, the greater the likelihood it will dominate other competing reactions. The mineralization processes involved are aerobic mineralization, denitrification, iron reduction, sulfate reduction, and methanogenesis. Since electron acceptors are usually supplied from the water phase, the different processes will occur adjacent to each other, going from surface to deeper zones, in the same characteristic sequence mentioned. The stratification is not necessarily strict, and processes do not necessarily exclude each other, for example, there is no thermodynamic argument why methanogenesis does not occur under aerobic conditions. Inhibition and regulation on the cell level are strong determinants for the stratification. Denitrification is inhibited usually by oxygen, although an exception was reported (Robertson 1983). Consequently, denitrification is located directly adjacent to the aerobic zone, with some possible overlap in the microaerobic zone (Lorenzen 1998; De Beer and Sweerts 1989; Robertson 1995). Sulfate reducers were thought to be very sensitive to oxygen, and thus restricted to anoxic zones. However, recently sulfate reducers were found in oxic zones of biofilms, sediments, and microbial mats (Dilling 1990; Krekeler et al. 1997). Furthermore, there is evidence that sulfate reducers

can be sulfidogenically active under aerobic conditions (Canfield and Des Marais 1991). Even more confusing was the finding of sulfate reducers that oxidize sulfide aerobically (Fuseler 1996). Sediments are not fundamentally different from biofilms, and both can be considered as matrices with localized (evidence suggests that cells are not immobilized but can swim around inside the cell clusters) microorganisms. All these processes may occur in biofilms as well, although in the relatively thin and heterogeneous biofilms, a stratification of processes and organisms may not be as pronounced and may be more difficult to study.

Owing to the short distances in biofilms, the different conversion processes can be tightly coupled and internal cycling occurs. Organic matter is subjected to hydrolysis and fermentation, producing volatile fatty acids and hydrogen. These products and the original organic matter serve as e-donors for anaerobic and aerobic respiration and methanogenesis. In the oxic zone, products from anaerobic redox processes like sulfide, methane, and Fe^{2+} are oxidized. Thus, internal cycles are possible, which cannot be quantified from interfacial fluxes. Such sequences of processes can only be detected by invasive techniques with high spatial resolution, that is, by microsensors.

An important internal cycle in biofilms is sulfate reduction coupled to sulfide oxidation. It is well known that sulfate reduction contributes considerably to the mineralization process in marine sediments (Jørgensen 1977, 1985; Jørgensen and Des Marais 1990; Thamdrup 1996). Because of reoxidation by aerobic and anaerobic processes, sulfide does not reach the top of the sediment. The importance of sulfate reduction in marine environments is usually explained by the high sulfate concentrations in seawater. However, also in freshwater systems, the sulfur cycle can be important. In aerobic wastewater biofilms, a significant part of the mineralization occurs by sulfate reducers. It was demonstrated with microsensors for S^{2-} that 50 % of the oxygen was used for sulfide oxidation, implying that 50 % of the mineralization of organic matter is degraded by sulfate reduction (Kühl and Jørgensen 1992). In similar biofilms, a combination of molecular techniques and microsensor techniques was used to relate microbial activity with microbial population distributions (Ramsing et al. 1993). A good correlation was found with the distribution of sulfate reducers and sulfide production in these biofilms, which were both confined to the anoxic zones. However, owing to the metabolic versatility of sulfate reducers and their resistance to oxygen, such a good correlation between microbial populations and microbial conversions is not obvious. Recently, the development of sulfate reduction in an aerobic biofilm was studied with microsensor and molecular analyses (Santegoeds et al. 1998). It was found that sulfate reduction coupled to sulfide oxidation began only after 6 weeks, although anoxic zones were present by the first week. Once started, this process became of major importance, resulting in up to 70 % of the mineralization in the biofilm. Thus, sulfate reduction can be an important process even in thin biofilms that are exposed to oxygen.

In the absence of nitrate, sulfide is oxidized by oxygen, and thus, the oxygen and sulfide profiles overlap. Upon addition of

nitrate, a separation between the sulfide and oxygen profile occurs because nitrate penetrates beyond the oxic layer and becomes the e-acceptor for sulfide oxidation (Kühl and Jørgensen 1992). Furthermore, iron and manganese form important shuttles for redox equivalents in marine sediments (Canfield 1991). Their role in biofilms is not known.

When illuminated, photosynthesizing biofilms are found. In such communities, a most complex internal cycling exists as these biofilms are in principle self-supporting. In the photic zone, CO₂ is bound in the biomass and O₂ produced. In the aerobic and anaerobic zones, the biomass is degraded to CO₂. In such systems, a large array of microbial processes can be found. Especially in microbial mats from extreme environments, such as hot springs or hypersaline lakes, undisturbed stratification of the different processes occurs. Microbial mats are actually complete ecosystems, where primary production is balanced by aerobic and anaerobic respiratory processes. Such communities are therefore highly interesting model systems. For further information on these systems, we refer to reviews (Pearl 1996; Stal 1994).

The main processes in the nitrogen cycle are ammonification due to degradation of organic matter, nitrification, and denitrification. Since the product of denitrification is N₂ gas, the nitrogen cycle in biofilms is not closed but depends on input of nitrogen compounds. Since nitrification is an aerobic process and denitrification proceeds primarily in the absence of oxygen, a clear stratification can be expected. Indeed, using microsensors, it could be confirmed that nitrate is formed in the oxic and consumed in the anoxic zone (Schramm and Amann 1999; Schramm et al. 1996; De Beer 1998; De Beer et al. 1997b). Nitrification is usually limited by oxygen penetration and confined to an outer layer of ca. 100- μ m thick (De Beer et al. 1993; Schramm 1998a). The intermediate nitrite can be found in a narrow zone near the oxic-anoxic interface, where it is formed by either incomplete nitrification or denitrification (De Beer et al. 1997b). In biofilms, denitrification is regulated by oxygen in several ways: firstly by inhibition, secondly by nitrification in the oxic zone, and finally by transport. Denitrification takes place adjacent to the oxic zone. At higher oxygen levels, the thicker oxic zone forms a transport resistance for nitrate from the water phase.

The competition between sulfate reduction and methanogenesis for e-donors has been investigated intensively. Sulfate reduction has more favorable thermodynamics than methanogenesis (Widdel 1988). Thus, methanogenesis is typically a more important process in low-sulfate environments (freshwater), and sulfate reduction dominates in marine sediments. Anaerobic reactors are usually designed for methane production, while sulfide production is an unwanted process because of odor and corrosion problems. In practice, both processes are active, resulting in biogas that is polluted with sulfide. Based on modeling, it was concluded that, under sulfate-limiting conditions, the outer layers of anaerobic biofilms or aggregates would be sulfidogenic, leaving a microniche for methanogens in the center (Overmeire et al. 1994). Such a division was indeed found: methane and sulfide microprofiles showed that sulfate reduction is confined to the outer 100 μ m, while methanogenesis occurs in the center (Santegoeds 1999a). This was also observed in aggregates

preincubated for months in excess sulfate and e-donor, that is, where sulfate reducers were expected to be present in the center as well. It was hypothesized that methanogens are needed for initial aggregate formation, while sulfate reduction develops subsequently. However, it is strange that sulfate-reducing bacteria (SRB) do not eventually colonize the aggregate center.

From the previously reviewed literature, it can be concluded that the sequence of e-acceptor use found in sediments is also present in biofilms. This was almost comprehensively demonstrated with microsensors in wastewater biofilms (De Beer 1999). First, O₂ is used by heterotrophic and autotrophic processes (nitrification and sulfide oxidation). Then NO₂⁻ and NO₃⁻, formed by nitrification or originating from the water phase, are consumed in the zone directly adjacent to the oxic layer. Denitrification can be coupled to sulfide oxidation. Sulfate reduction is found below the denitrifying zone. Methanogenesis is also spatially separated from sulfate reduction and occurs in the deepest zones of the biofilms.

Special Physiology of Biofilm Cells?

Since biofilms function differently in many aspects from planktonic cells, it has often been speculated that a special biofilm physiology exists (Cochran et al. 2000). Biofilms usually have a lower specific conversion rate, high resistance toward biocides and antibiotics, and less sensitivity to temperature changes. It has been argued that all these phenomena can be explained by mass-transfer resistance (van Loosdrecht et al. 1990). Mass-transfer resistance reduces the transport of substrates and biocides to the cells, even if they form only a monolayer. Due to mass-transfer resistance, only a partial penetration of substrate occurs, but under conditions of reduced cellular activity (e.g., by cooling), a larger part of the biofilm gets penetrated with substrate, which counteracts the reduced specific conversion rates in each cell. Two other explanations for the reduced efficacy of biocides and antibiotics are the relatively low growth rates of biofilm cells, which make them less susceptible (Brown and Gilbert 1993), and the reduced penetration either by binding of compounds to the biofilm matrix or, in case of reactive biocides, by deactivation in the outer layers of the biofilm (Stewart et al. 1996). It appears that rather than a special biofilm physiology, the growth and activity of the cells within the biofilm may be governed by the physiochemical conditions that prevail in the biofilm microenvironment.

However, more and more evidence indicates that cells recognize and respond to the presence of other cells and surfaces in their environment. It has been shown that after attachment certain genes required for EPS synthesis are activated (Davies and Geesey 1995) and that the production of pheromones (homoserine lactones) induces biofilm formation (Davies et al. 1998). Thus, the development of a mature biofilm involves the same compounds involved in quorum sensing (Greenberg 1997). It was carefully hypothesized that cell-cell signaling might be involved in the resistance of biofilms to biocides (Costerton et al. 1999). See further in the paragraph on section 13.2 “Morphogenetic Factors.”

Microbial Populations

Previously, microbial population analysis was based on enrichment and cultivation techniques. It has become clear that plate counts very often do not represent the true microbial community, as many strains are resistant to cultivation. Microbial analysis has become much more reliable (and easier) due to the development of noncultivation techniques. Owing to the relative ease of molecular techniques, many data are collected from a wide variety of microbial communities; however, the role of the detected populations is often not known. This can be attributed to the difficulty of functional analysis of complex communities: the conversions of a community can be measured, but it is difficult and often impossible to assign the conversion to certain populations. However, there are some exceptions. Some microbial populations can be analyzed with a combination of microsensor and molecular techniques. Then, it is possible to determine the location of certain microbial processes (with microsensors) and to determine the location of certain microbial populations (with fluorescent in situ hybridization, FISH). Comparing these data can lead to estimations of activities and kinetics of populations in situ.

The combination of molecular and microsensor techniques was first used in a biofilm from a trickling filter (Ramsing et al. 1993). Sulfide profiles were measured with AgS microsensors from which the distribution of sulfate reduction and sulfide oxidation was determined. With oligonucleotide probes (SRB385), the distribution of SRB was determined, although it is now known that the probe is not targeting SRB exclusively. Once a reasonable agreement between the distribution of SRB and sulfate-reducing zones was found, the in situ activity could be estimated. However, SRB were also found in the oxic zones. Although 50 % of the mineralization was done by sulfate reduction, only 10^8 – 10^9 SRB per ml were found, which was probably less than 1 % of the total number of cells.

In a more detailed study, the development of the number and distribution of SRB as well as that of sulfate reduction was followed in a biofilm developing in a wastewater treatment plant. Although anoxic conditions were present from the first week on, no sulfate reduction could be detected until the sixth week. More surprisingly, SRB were present also in the initial biofilm as shown with various molecular techniques (DGGE, denaturing gradient gel electrophoresis; FISH; Santegoeds et al. 1998). A better correlation between molecular and functional analysis was found when comparing the presence of the functional gene for bisulfite reductase (DSR) and sulfate reduction (Santegoeds 1999a), as the start of the sulfate reduction coincided with a strong increase of the signal for DSR. Thus, the presence of a functional gene in a complex microbial community seems more predictive for its behavior than a population analysis. However, in activated sludge DSR could be clearly demonstrated, but sulfate reduction was absent, even upon exposure to anoxia in the presence of a suitable cocktail of e-donor (Schramm and Amann 1999). This points again to the fact that observed populations and biodiversity do not necessarily reflect the behavior of the community at the time

of sampling. Many ecosystems and microbial communities are open, and thus, exchange of strains is occurring frequently. For example, wastewater treatment systems, which are the subject of many diversity studies, have an enormous input of microorganisms that are collected from a wide area or are grown in the sewer system. It is likely that the observed sulfate reducers in activated sludge originate from the input and the SRB populations need time to adapt to the conditions in the wastewater treatment plant.

In methanogenic aggregates a good correlation was found between the distribution of SRB and sulfate reduction, as well as between the distribution of methanogenic bacteria (MB) and methanogenesis. SRB were mostly found on the outside, while MB form the core of the aggregates. In between was a layer of syntrophic bacteria, which were found to supply both the SRB and MB with H_2 and acetate. In aggregates from a reactor optimized for sulfate reduction, few MB and little methanogenesis were found. In aggregates from a reactor optimized for methanogenesis, no SRB or sulfate reduction was detected (Santegoeds 1999a). The difference between anaerobic aggregates and the previously studied biofilms and activated sludge is age: while the biofilms and flocs had a life cycle of months or weeks, anaerobic aggregates develop over years. Probably, the SRB populations found in flocs and biofilms originated from outside the biofilms and flocs, and since they did not reduce sulfate, they were not adapted to the environment inside the studied communities. Thus, population analysis based on nucleic acid analysis must be regarded with care. It can be concluded that although certain physiological groups may be present, they may not necessarily be active. The presence of a population will only reflect the functioning of a microbial community if the community is mature and its populations well adapted to its environment.

A good correlation between activity and presence of populations is often found in nitrifying biofilms. In a high-loaded biofilm reactor from a fish hatchery, nitrate microprofiles showed nitrification in the aerobic surface layer and denitrification in the deeper anoxic zone. With FISH, populations of ammonium- and nitrite-oxidizing *Nitrosomonas* and *Nitrobacter* strains were found predominantly in this outer zone (Schramm et al. 1996). Nitrification is generally thought to be mediated mainly by *Nitrosomonas* and *Nitrobacter* strains because these are the main species that can be isolated from environmental samples. However, with molecular techniques these strains are seldom detectable in environmental samples. In aggregates from a rather low-loaded, fluidized bed reactor, intense nitrification was measured, but no nitrifying populations were found with the probes for *Nitrosomonas* and *Nitrobacter*. DNA was extracted, 16S-RNA coding fragments amplified with PCR and sequenced, and after comparison with the databases, new probes were designed. The nitrifiers that were found were new *Nitrosospira* and *Nitrospira* strains, which could not be grown in culture. With FISH and by using these probes, quantification of the different populations was possible, and from the microprofiles, local activities were obtained. Thus, nitrifying activities could be estimated under different

well-chosen conditions, even allowing in situ determination of Monod parameters (Schramm et al. 1998b) of up-to-now uncultured strains. The newly found strains had much lower specific activity and K_s than the known *Nitrosomonas* and *Nitrobacter*, implying a different survival strategy. In biofilms, they were found mainly in areas with low oxygen concentrations (Schramm 1998a). *Nitrosospira* and *Nitrospira* strains are adapted to low nutrient and oxygen concentrations (K-strategy), while *Nitrosomonas* and *Nitrobacter* can compete with their much higher conversion (and probably growth) rates at high nutrient and oxygen concentrations (G-strategy).

Previously described in situ studies, activity of populations was determined using a combination of FISH and microautoradiography, but activity determinations of single cells are also possible (Nielsen et al. 1998). Populations of filamentous bacteria from activated sludge were identified with probes for type 021N (strain identification according to Eikelboom key) and for *Thiothrix*. Uptake of six different organic substrates (^{14}C - or ^3H -labeled) under aerobic conditions revealed that no filaments took up all substrates and that strains, indistinguishable by morphology and molecular probes, showed differences in uptake patterns. This means again that great care must be taken when interpreting population structure of a complex community from the way its components function (Okabe 1997).

Biofilm Control

Biofouling is the detrimental development of biofilms in engineered systems, such as industrial process equipment, drinking water distribution systems, and ship hulls. Biofilms can decrease heat transfer in heat exchangers, increase the pressure drop in pipelines, enhance corrosion, and may be a source of bacterial contamination of drinking water (McCoy 1987; Camper 1994; Characklis 1990b). Biofilms are a nuisance in these systems and control of their development may be necessary to maintain process efficiency and safety. Biofilm control is often performed with biocides, of which the most commonly used is chlorine, a strong oxidizing agent and disinfectant. Biocides are much less effective against biofilms than suspended cells (Chen et al. 1993; Nichols 1988; LeChevallier et al. 1988). Cells in biofilms are protected from biocide action and are killed only at biocide concentrations orders of magnitude higher than those necessary to kill suspended cells. It has been speculated that the lower sensitivity of biofilm cells to biocides is the result of physiological differences associated with lower growth rate (Brown and Gilbert 1993). Alternatively, biocide may not reach the cells due to diffusional resistance of the biofilm matrix or to neutralization of biocide inside the matrix (Stewart et al. 1996). There is evidence for both theories.

Using a microsensor for chlorine, it was shown that chlorine penetrates very slowly in biofilms (De Beer et al. 1994). The shape of the chlorine profiles, the long equilibration times, and the dependence on the bulk chlorine concentration showed that the penetration was a function of simultaneous reaction and diffusion of chlorine in the biofilm matrix. Frozen cross sections

of biofilms, stained with metabolic stain 5-cyano-2,3-ditolyl tetrazolium chloride (CTC; a redox dye), showed that the chlorine penetration overlapped with non-respiring zones near the biofilm-bulk fluid interface. Thus, chlorine was reduced effectively at the surface of the biofilm, which prevented its penetration to the cells in the deeper layers and thereby protected them. See further information in the section on [“Cell-Cell Signaling.”](#)

Methods for Studying Biofilms

Cultivation

Laboratory-Scale Cultivation

All reactors used for cultivation of biofilms must be designed so that a selective advantage exists for cells to grow in biofilms and not in suspension. It must be kept in mind that cells in biofilms have a transport limitation not shared by suspended cells, which gives suspended cells in a reactor a selective advantage. In general, growth of suspended cells will interfere with biofilm behavior and thus complicate the interpretation of the experiment. Suspended cells can more efficiently compete for the limiting substrates, leaving little available for biofilms attached to the reactor surface. Consequently, in biofilm experiments suspended growth must be suppressed. Alternatively, certain selective pressures may favor biofilm formation. For example, biofilm formation may protect cells within the biofilm from the action of biocides or grazing predators (Costerton et al. 1994; Stewart et al. 1996). When biofilm growth is to be studied under controlled conditions, for example, pure or defined mixed cultures and constant conditions, ideally reactor conditions should be chosen so that the residence time of the liquid is shorter than the generation time of the cells. Then the suspended cells will be washed out, and the substrate is available for biofilm growth. This was nicely demonstrated by experiments that stepwise decreased the residence time of a culture (Beefink 1987a). When the residence time became shorter than the generation time of the cells, washout occurred accompanied by a temporary increase of the substrate concentration. Subsequently, attached cell mass proliferated and the substrate concentration decreased again.

The particular design of a reactor system depends on the type of experiment, that is, the type of process, conditions desired, and monitoring techniques applied. Besides the residence time of the medium, also the hydrodynamic regime and the microenvironment in the reactor, that is, axial gradients, should be considered. The presence of stagnant zones must be avoided. The hydrodynamics should be predictable, and sudden expansions or contractions or sharp bends should be avoided where possible. For the medium supply, one can choose a once-through system, in which fresh, sterile medium is pumped through the biofilm compartment. This ensures good control over the substrate concentrations. However, to obtain a sufficiently high flow rate to avoid axial gradients and stagnant zones, large amounts of medium are needed. Most reactor

systems are operated with a continuous supply of medium, sufficient to ensure that the residence time of the medium is shorter than the generation time of the cultures, and a recycle allowing reconditioning of the medium (e.g., aeration and pH control) and control over the hydrodynamics of the biofilm. The design is often a compromise dictated by common sense. If experiments are to be done on pure cultures, a simple system that can be sterilized is preferred. Certain accommodations must be made for specific measurements, for example, observation windows for in situ microscopy, removable slides for biofilm sampling, openings for the introduction of microsensors, and so forth.

Flow Cells

One of the most widely used reactors for biofilm study is the flow cell. The system can be very simple, made of two microscopic slides and a spacer (Caldwell and Lawrence 1988; Wolfaardt et al. 1995; Lawrence et al. 1991), which is ideal for microscopic monitoring of biofilms. The volume is small; therefore, a one-way medium supply can be used. It can easily be sterilized and so be used for pure cultures. A more complicated flow cell is needed when the biofilm is monitored with microsensors. Either a closed flow cell with openings for introduction of the sensors (De Beer et al. 1994) or an open flow cell is used (Horn and Hempel 1997). Since these flow cells are larger, a recycle is needed to obtain good mixing of the water phase. A special type of flow cell is the Robbins device (Whiteley et al. 1997; Sly et al. 1990), essentially a pipe with sample holders, with the surface flush with the lining of the pipe. The sample holders are removable, allowing multiple biofilm sampling. Also, flow cells with observation windows for microscopy have been equipped with pressure- and flowmeters to study the interaction of hydrodynamics and biofilm accumulation (Stoodley et al. 1998).

A special flow cell was developed for immobilization of marine snow flocs (Ploug and Jørgensen 1998). The device (called net-jet) consists of a cylinder with a fine stocking separating the top and bottom part. The hydrodynamics are not well understood, but this simple device allows fixation of flocs in an upward water stream. The flocs can be penetrated by microsensors under settling conditions, resembling the normal hydraulic regime. In this flow cell, also activated sludge flocs with a diameter of 0.2–1.5 mm were investigated (De Beer 1998). If flow cells are well designed, the hydrodynamics can be well characterized (in contrast with many other types of bioreactor), allowing the influence of fluid shear and mass transfer on biofilm processes such as adhesion, detachment, and biotransformation rates.

Annular Biofilm Reactor

The annular reactor is essentially a chemostat consisting of a cylinder rotating in an outer cylinder with the reactor content

between the outer and inner cylinder (Characklis 1988). The outer cylinder can be equipped with removable sample plates that are flush with the surface. The inner cylinder rotates at variable speed, thus allowing adjustment of the hydraulic regime over a wide range, independent of the residence time of the medium. With this device, many studies have been done on initial biofilm formation (Escher and Characklis 1990), the effect of biofilms on shear stress (Characklis 1990), and the effect of hydraulics on biofilm formation (Gjaltema et al. 1994). It is difficult to maintain a pure culture in these reactors. The hydraulics are not well described and not uniform (Gjaltema et al. 1994). Therefore, it now is recognized that this device cannot easily be used for quantitative studies.

Fowler Cell

Hydrodynamics are important for the attachment of cells and development of biofilm. The Fowler cell (Fowler 1988) is a radial flow cell, consisting of two plates mounted parallel to each other. The inlet is mounted in the center so that flow occurs radially, from the center to the periphery. The flow velocity is the highest in the center and decreases with increasing radial distance. The shear forces can be calculated assuming a flat geometry.

The Modified Robbins Device (MRD)

The MRD consists of a square or rectangular channel in a polycarbonate block in which 25 sampling-port studs are inserted along the length of the MRD (Hall-Stoodley et al. 1999). The studs can be fitted with different materials to investigate biofilm formation on different surfaces. The MRD is usually sterilized with ethylene oxide and the studs can be removed aseptically. The advantage of the system is that several samples can be taken simultaneously at different times to study biofilm development. Quantification, such as viable and total cell counts, total protein, and carbohydrate content, is possible on scraped samples. Although it is not possible to observe the biofilms in situ, microscopic analysis is possible using conventional staining techniques of slide-mounted samples or by electron microscopy of the colonized surfaces. The MRD is also relatively inexpensive. It can be used in both batch recirculating and once-through culture systems or can be connected to a chemostat. The major disadvantages of the MRD are the inability to directly observe the biofilm, the possible formation of significant nutrient gradients along the length of the device, and possible eddy generation around the sampling studs.

Constant-Depth Fermenter

Biofilms actually never reach a steady state, in which cell growth is balanced by decay and abrasion. Instead, biofilm development is characterized by colonization, growth, and sloughing

events and then by regrowth. A special type of biofilm reactor is designed in which the top of the biofilm is constantly (a few times per minute) scraped off and a constant thickness is maintained (Peters and Wimpenny 1988). Biofilms are grown in plugged holes in a plate, over which a plastic scraper rotates. In this model system, flat biofilms were obtained, which have several advantages including ease of microprofile interpretation, facilitated determination of *D*, multiple sampling (30 biofilm surfaces per plate), mass balances throughout the reactor accurately related to the biofilm surface, successional population changes to a steady-state situation followed, and spatial heterogeneity of populations determined (Wimpenny 1996). The obvious disadvantage of this approach is that the control of the biofilm thickness is very artificial. While in normal conditions an irregular surface develops, perfectly flat biofilms are formed in this model system.

Reactors for Biofilms on Carriers

A step in the direction of applied biofilm reactors is to downscale them to laboratory-size systems. Most applied biofilm reactor systems are based on biofilms on carrier-aggregated biomass, such as gas-lift reactors (GLR), fluid-bed reactors (FBR) and upflow anaerobic sludge blanket (UASB) reactors. Gas-lift reactors are attractive laboratory systems as the behavior is almost scale independent (Beefink 1987b), facilitating good comparison with full-scale systems. Moreover, they are well mixed and the amount of samples that can be taken without disturbing the reactor is large. The GLR consist of two reactor compartments, a riser and a downcomer. Gas is pumped in the riser, resulting in an upflow of the water-gas-aggregate mixture. At the top of the riser, the gas is separated, and the water-aggregate mixture goes down in the reactor through the downcomer. In aerobic GLR, the gas is used for efficient aeration and mixing (Van Houten et al. 1994; van Loosdrecht et al. 1997; Gjaltema et al. 1997); in an anaerobic GLR oxygen-free gas is recycled for mixing only (Beefink and Staugaard 1986; Van Houten et al. 1994). The advantage of mixing with gas over mechanical devices (impellers) is the relatively low power input and thus low shear forces. The reactor is completed with an internal or external settler to separate aggregates from the effluent stream.

The FBR is based on suspending aggregates on an upwardly directed liquid flow. This reactor is less well mixed, and axial substrate and product gradients develop. This may be a disadvantage for practical use, but for microbial ecology studies such gradient systems can be very useful (Csikor et al. 1994; Buffiere et al. 1995; Shieh and Hsu 1996; Schramm 1998a; De Beer et al. 1993).

The UASBs are used commonly for anaerobic treatment of concentrated wastewater. In these reactors, the hydrodynamic regime is so quiet that the aggregates are constantly settling in a sludge layer at the bottom (Hulshoff Pol 1989; Lettinga 1995). Laboratory-scale UASB with a volume of 1–3 l have been used to study methanogenic and sulfidogenic

consortia (Thaveeshi et al. 1995; Harada et al. 1994; Koster 1989) as well as start-up phenomena of methanogenic biofilm reactors (Hulshoff Pol 1989).

Microscopic and Staining Methods

Microscopy

Scanning electron microscopy (SEM), transmission electron microscopy (TEM), normal light microscopy (LM), fluorescence microscopy (FM), and confocal scanning laser microscopy (CSLM) all have been used to study biofilms (Surman et al. 1996). Most microscopic methods involve some preparation of the sample, including staining, fixation, freezing, dehydration, embedding, and sectioning. For this reason, it is important to realize that biofilms are soft and mostly consist of water (<95 %) (Christensen and Characklis 1990). Preparations for microscopy may significantly change the matrix structure by shrinking and deformation (Stewart et al. 1995), and the resulting artifacts have influenced the concept of biofilm structure for years. Most relevant is the underestimation of the spatial heterogeneity, as several steps in the preparation may level the soft biofilm structures. Then, EPS appears as strands connecting the cells. EPS morphology changes by dehydration: diffuse polymeric matter is condensed to strands, leading to overestimation of the pore size. From SEM images the pore size appears to be in the order of 1 μm . Good TEM preparations show a pore size of ca. 100 nm (Beefink and Staugaard 1986).

Images acquired by ESEM (Little et al. 1991) and atomic force microscopy (AFM; Bremer et al. 1992) with sub- μm resolution (no dehydration) do not show these strands but rather a smooth smear. A possible artifact from ESEM is the filling of recesses by water, “drowning” the roughness elements of the surface. The sensor needle of the AFM might disturb the surrounding water, causing the polymers to move and resulting in a blurred image (Bremer et al. 1992). Samples examined by LM, FM, AFM, ESEM, and CSLM can be unfixed. The recent application of CSLM has been especially instrumental in changing our concepts of biofilm structure (Lawrence et al. 1991; Massol-Deya et al. 1995; De Beer et al. 1994). With the CSL microscope, living transparent tissues can be sectioned optically, under growth conditions. In as much as out-of-focus fluorescence is effectively removed by the pinhole, the images are much sharper than standard microscopic images. Lawrence et al. (1991) published an excellent description of confocal microscopy techniques for biofilm research. Scanning electron microscopy, ESEM and AFM can be used for surface scanning, while the other techniques to some extent allow observation below the surface.

Staining

Specific staining is an important tool to unravel the spatial distribution of different biofilm components, most importantly

■ **Table 13.5**
Dyes for structural analysis of biofilms and microbial mats

Structure	Dye	Microscopy	Staining
Cells	Classical stains (crystal violet, Gram, etc.)	LM	All cells
	Acridine orange DAPI	FM and CSLM	All cells
	Ethidium bromide	FM and CSLM	Dead cells
	Eropidium iodide		
	Hexidium iodide	FM	Living cells
	CTC, formamide	FM and CSLM	Respiratory active cells
Voids and channels	Dextran conjugate	FM	Voids
	Beads	FM and CSLM	Voids
	Fluorescein	CSLM	Voids
EPS	Alcian blue	LM	EPS (carbohydrates)
	Lectins	FM and CSLM	EPS (carbohydrates)
	Calcofluor	FM and CSLM	EPS (carbohydrates)
	FITC	FM and CSLM	EPS (proteins)
	Heavy metals	TEM	Cells, EPS

Abbreviations as stated in Table 13.4; DAPI 4',6-diamidino-2-phenylindole, CTC cyanoditoly tetrazolium chloride

in cells, EPS and voids (Table 13.5). For viewing cells, stains nonspecific for DNA, such as acridine orange, diamidino-phenylindole (DAPI), ethidium bromide, and hexidium iodide are most useful. These dyes can be combined with confocal microscopy, thus giving an image of cell distributions in undisturbed biofilms or mats. Species-specific staining by oligonucleotide probes or antibodies will be treated elsewhere.

Much less attention has been paid to visualization of EPS. Staining of EPS for fluorescent microscopy or CSLM is possible for proteins (fluorescein isothiocyanate), polyuronic acids and polysaccharides (lectin conjugates, calcofluor). Calcofluor stains most polysaccharides (attaching to β -1,4 and β -1,3 polysaccharides; Haigler et al. 1980), while lectins are more specific. Also, EPS dyes will stain cells that become visible as discrete points, whereas EPS appears as a continuous sheet. *The Handbook of Fluorescent Probes and Research Chemicals* (a catalog of molecular probes) is a highly valuable source of information about dyes and staining techniques (Haugland 1996). Also, EPS can be stained by ruthenium red for TEM or observed directly by SEM. Voids can be made visible with negative staining using fluorescein that is quenched by the presence of biomass. Using CSLM, voids appear as bright fluorescent areas, while biomass remains dark (see Fig. 13.6, De Beer et al. 1994; Lawrence et al. 1991). Also fluorescent microbeads can be used that penetrate the voids but not the cell clusters (Stoodley 1998) (Fig. 13.6).

In conclusion, several new microscopic techniques now make it possible to get a much more detailed view of biofilm structure.

Microbial Activity

As biofilms consist of thin but often dense layers of cells, many trophic interactions between different populations may occur

on a small scale. Examples are nitrification and denitrification, sulfate reduction and sulfide oxidation, and photosynthesis and respiration. Few methods are suitable to measure in situ these coupled processes on such a small scale. Activity tests on subsamples give at best an impression of the distribution of potential activities but do not reflect the actual rates (Okabe et al. 1996). Analysis based on in situ detection of mRNA is not developed as yet for complex communities, and its value as a quantitative method is doubtful. With autoradiography, it was possible to detect substrate use on a cell level (Andreasen and Nielsen 1997); however, this method does not give local rates. Microsensor techniques are probably the most suitable for unraveling processes in thin complex communities. The local net consumption or production rates can be calculated from microprofiles with a spatial resolution of 25–50 μm . The main prerequisite is that the different processes must be spatially separated, with a distance of some tens of microns (with the exception of coupled photosynthesis and respiration).

Microsensors

Depending on growth conditions and age, the thickness of biofilms, aggregates and flocs can reach from μm to cm, and the structural heterogeneity can be pronounced. The active zones are typically on the order of a few mm or less. This requires experimental techniques with a high spatial resolution, and here microsensors have proven highly useful tools to study the biofilm and mat microenvironments and microbial activities in immobilized cell systems (including sediments). Microsensors are needle-shaped devices with a tip size of 1–20 μm and can measure the concentration of a specific compound. Owing to the small sensing tip, highly localized measurements

are possible. Although the technique is invasive, the small tips do not influence structures or processes significantly. With microsensors, the spatial distribution of substrates and products can be determined, and from this, the distribution of microbial activity can be inferred.

Niels-Peter Revsbech introduced microsensors in microbial ecology (Revsbech 1983) and also constructed the first reliable O_2 microsensors for profiling sediments and biofilms (Revsbech 1989). Other microsensors relevant for microbial ecology were developed and used, such as for N_2O (Revsbech et al. 1988), pH (Hinke 1969; Lee and De Beer 1995), NH_4^+ (De Beer and van den Heuvel 1988), NO_3^- (De Beer and Sweerts 1989; Larsen et al. 1996), S^{2-} (Revsbech 1983), H_2S (Jeroschewski 1996), NO_2^- (De Beer et al. 1997), CH_4 (Damgaard and Revsbech 1997; Damgaard 1995), CO_2 (De Beer et al. 1997), and $HClO$ (De Beer et al. 1994) determination. Reviews have been published on construction and use of microsensors and on interpretation of results (Thomas 1978; Revsbech 1986; Kühl and Revsbech 1998; De Beer 1998, 1999). Here only a brief summary is given. Microsensors are based on amperometric, potentiometric, or optical principles.

Amperometric sensors are based on current measurements induced by the electrochemical reduction or oxidation of the substrate in the tip, with a rate proportional (usually linearly) to its concentration. Useful O_2 , N_2O , H_2S , and $HClO$ sensors are based on this principle. Many research groups have used O_2 microsensors for study of photosynthesis and respiration. Such studies are done in biofilms (De Beer et al. 1994; Kühl and Jørgensen 1992; Lewandowski 1991; Zhang 1994; Harmer and Bishop 1992; Zhang 1996), activated sludge flocs (Schramm 1998a; Lens et al. 1995), and marine snow (Ploug et al. 1997). The N_2O sensor has been used for denitrification studies in biofilms and microbial mats (Revsbech et al. 1988); the development of nitrate sensors has made this sensor obsolete for this purpose. The new H_2S sensor is used to study sulfate reduction and sulfide oxidation in biofilms (Santegoeds et al. 1998) and activated sludge (Schramm et al. 1998b). The $HClO$ microsensor is used in biofilm disinfection studies (De Beer et al. 1994; Xu et al. 1995).

The variety of measurable substrates has been expanded by applying enzymes or bacteria as catalysts for the formation or consumption of redox-active compounds in the sensor. Glucose oxidase has been used for glucose sensors (Cronenberg et al. 1991), cultures of methane oxidizers in methane sensors (Damgaard and Revsbech 1997), and pure cultures of incomplete denitrifiers in nitrate and nitrite sensors (Larsen et al. 1997, 1996).

Potentiometric microsensors measure electrical potential generated at the tip by charge separation. The oldest potentiometric microsensor is the full glass pH sensor (Hinke 1969). It is versatile (Revsbech 1986), has a low spatial resolution owing to its 100- μm long tip, and has a ca. 30-s response time. The AgS-membrane S^{2-} electrode has been very useful in studies of the sulfur cycle in microbial mats and biofilms (Kühl and Jørgensen 1992; Revsbech 1983), but it must be used with care and in absence of oxygen. The H_2S sensor has no such problems and

can be used for the same research. The H_2S sensor is most suitable for environments with low pH (>8), whereas the S^{2-} sensor may still be necessary in environments with high pH. The liquid membrane ion-exchanging (LIX) microsensor technique was developed by cell physiologists for intracellular measurements (mostly of CO_3^{2-} , Mg^{2+} , Li^+ , Na^+ and K^+). These sensors can be very small (with a tip diameter of less than 1 μm , the size of a bacterial cell) and are used to measure NH_4^+ (De Beer and van den Heuvel 1988), NO_3^- (De Beer and Sweerts 1989; Jensen 1993), NO_2^- (De Beer et al. 1997), H^+ (Schulthess et al. 1981), CO_2 (De Beer et al. 1997), or CO_3^- (Müller et al. 1998). The NH_4^+ , NO_3^- , and NO_2^- sensors are used to study the nitrogen cycle in biofilms and in sediments from freshwater environments (De Beer et al. 1991; Sweerts and De Beer 1989; Jensen 1993; De Beer et al. 1997), and the H^+ and CO_2 sensors are used for studies on photosynthesis and respiration in algal mats.

Ion-selective microsensors have some disadvantages. Often their selectivity is not very high. Because of interference by Na^+ or Cl^- ions, measurements cannot be made in marine environments, with the exception of pH, S^{2-} , and Ca^{2+} . However, their value for studies in freshwater environments is high, and no alternative exists for NH_4^+ , NO_2^- , and NO_3^- microsensors. They last only ca. 1 day; however, they are easy to construct. Finally, these sensors have behaved unpredictably in some circumstances, readings drifting radically, for example, upon penetration of the biofilm. Most likely this is caused by dissolution of hydrophobic biofilm compounds in the LIX membrane. The microsensor can be protected from this phenomenon with a hydrophilic protein layer (De Beer et al. 1997).

Micro-optodes are based on the change of optical properties (fluorescence intensity or fluorescence lifetime) of a layer covering an optical microfiber. Microsensors are developed for O_2 , pH, and temperature. The presence of the substrate induces quenching of the fluorescence intensity or decrease of the fluorescence lifetime. Klimant et al. (1997) gave a description of the theory and practice of this technique. Advantages of optical sensors are their ease of manufacture, insensitivity to noise, stability of calibration, and mechanical strength. Disadvantages include their size (ca. 20 μm), limited types of sensors available, and cost of the opto-electronics.

Typical experiments measure transient concentration changes at a fixed position and concentration profiles. Transient concentration changes are measured during photosynthesis with the fast light-dark shift (Revsbech 1983) or for the in situ determination of diffusion coefficients (Cronenberg 1994a, b). For these types of experiments, we refer to the literature; the interpretation of profiles will be discussed below.

Interpretation of Profiles

Profiles give information on microbial activity as well as insight into the microenvironments in biofilms. Microprofiles depend on mass transfer and microbial conversions. Consequently, if the transport processes are known, information on the distribution of microbial activity can be derived from the measured profiles.

Because of microbial conversion and mass-transfer resistance effects, substrate and product profiles develop inside biofilms. If the biofilm is impermeable, diffusion is the only transport mechanism inside the matrix. The turbulent bulk liquid is usually well mixed by advective transport (transport by liquid flow). Adjacent to the matrix is a viscous boundary layer in which the mixing and flow velocity gradually decrease as the surface is approached. Consequently, the mode of transport changes gradually from advective in the bulk liquid to diffusional in the laminar boundary layer. Diffusional transport is driven by the concentration differences as expressed in Fick's law:

$$J = D \frac{dc}{dx} \quad (13.7)$$

where J is the flux ($\text{mol}\cdot\text{m}^{-2}\cdot\text{s}^{-1}$), D is the diffusion coefficient ($\text{m}^2\cdot\text{s}^{-1}$), dc is the change in concentration (in mols) over the distance dx (in meters), and dc/dx is the concentration gradient. In steady state, local conversion rates are equal to transport rates. Assuming a constant D , the mass balance becomes for a planar geometry

$$D \frac{d^2c}{dx^2} = r \quad (13.8)$$

where r is the conversion rate. With [Eq. 13.8](#), the concentration profiles can be calculated for zero- and first-order kinetics, assuming a homogeneous activity distribution. In reality, the assumptions are often too simple: conversions are of mixed-order kinetics (Monod) and the distribution of activity is varying with depth. Then only with iterative computer modeling, concentration profiles can be calculated. By fitting calculated with measured profiles, a good estimation can be made of the distribution of microbial activity (Revsbech 1986; Berg 1998). The executable code of the procedure from Berg et al. (1998) is available by e-mailing the author (pb8n@virginia.edu). A more direct approach is to derive the local activities from the profiles. Assuming a measured profile consisting of three measured points (a , b , and c), the flux between a and b and b and c can be calculated from [Eq. 13.7](#):

$$J_{ab} = D_{ab} \frac{(c_a - c_b)}{(x_a - x_b)} \quad \text{and} \quad J_{bc} = D_{bc} \frac{(c_b - c_c)}{(x_b - x_c)}$$

This gives the best estimate for the fluxes through the intermediate points between the measurements, $0.5(x_a + x_b)$ and $0.5(x_b + x_c)$. If the system is in steady state, then the difference in fluxes through these points is equal to the local conversion in point b , which is approximated by

$$r_b = \frac{J_{ab} - J_{bc}}{0.5(x_a + x_b) - 0.5(x_b + x_c)} \quad (13.9)$$

If D is constant with depth and we measure with constant depth intervals, δx , then

$$r_b = D \frac{c_a - 2c_b + c_c}{\Delta x^2} \quad (13.10)$$

This approach needs high spatial resolution microprofile measurements. Since noise is magnified, a smoothing procedure

is recommended. Alternatively, the profiles can be fitted with a polynome. Then the local fluxes are given by the product of the derivative of that polynomial function and D . The local activities are calculated by the product of the second derivative of the function and D .

When D_{eff} is varying with depth, the local fluxes must be calculated with the local D_{eff} using [Eq. 13.7](#), and local activities calculated with [Eq. 13.9](#). All these calculations can be conveniently done with a spreadsheet.

An example of such an analysis is given in [Fig. 13.19](#). In a biofilm, profiles of O_2 , NO_2^- , NO_3^- , and H_2S were measured. From these profiles, the aerobic respiration, nitrate consumption (denitrification), and sulfate reduction rates could be calculated. The analysis shows nicely the stratification of processes, that is, the sequence of used e-acceptors ([Fig. 13.20](#)).

Although activity profiles are valuable, combining these data with bacterial population distribution allows a more complete analysis of the microbial activities in biofilms. By aligning population and activity distributions, it can be determined which microorganisms are responsible for certain conversions (Ramsing et al. 1993; Santegoeds et al. 1998). The use of molecular techniques, techniques for population analysis (e.g., DGGE), and population distribution (using fluorescent in situ hybridization, FISH) has resulted in discovery of new species and their distribution within biofilms. With microsensor analysis and FISH, the ecological niche and kinetic data could be determined from these up-to-now uncultivable species (Schramm 1998a; Schramm et al. 1998b).

Population Analysis

Cultivation Techniques: Microslicing, Most Probable Number (MPN) Technique, and Plate Counting

The classical microbial approach for population analysis is based on cultivation techniques, such as plate counting and MPN. However, it has become clear that these techniques select for certain organisms and thus do not give quantitative data (Staley and Konopka 1985). Subpopulations of environmental samples cannot be cultivated and thus do not appear in MPN or plate counts (Torsvik et al. 1990; Wayne et al. 1987). Even key players of a community may not be identified (Wagner et al. 1993, 1994; Schramm et al. 1998b). Consequently, cultivation techniques give a strongly biased picture of complex microbial communities in biofilms. Moreover, assessment of microscale distribution of microorganisms is very difficult. Okabe et al. analyzed the distribution of heterotrophic and nitrifying organisms by slicing living biofilms horizontally in 100–250- μm -thick sections and enumerating organisms by MPN and plate counting (Okabe et al. 1996a, b). However, since active zones in biofilms are often in the order of 50–100 μm , even this fine-scale technique is too coarse. To avoid these limitations, techniques were developed for identification and counting without cultivation steps.

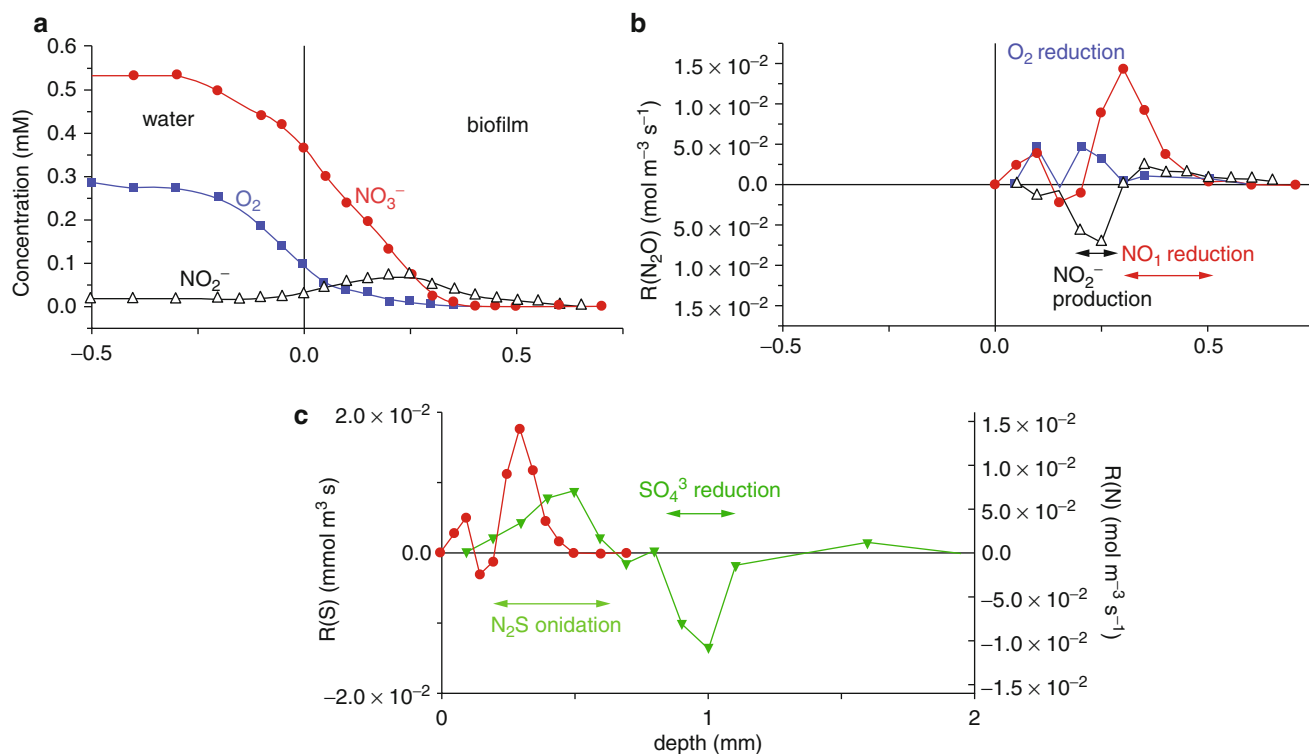

Fig. 13.20

Oxygen, nitrate, and nitrite profiles in a thick biofilm from a wastewater treatment plant (a) and local conversion rates calculated from these profiles (b). In (c) also the total sulfide conversion rates are plotted (sulfide profiles not shown), demonstrating that sulfide production occurs in the deep biofilm (ca. 1-mm depth) and sulfide oxidation overlaps with the denitrifying zone

Molecular Techniques

Species-specific detection of strains is possible with antibodies and analysis of nucleic acids. Both techniques have been used on preparations of dispersed communities (fingerprinting) and on intact biofilms or preparations in which the integrity is maintained (in situ detection). Fingerprinting with antibodies has been described for nitrifiers (Sanden et al. 1994; Both et al. 1992) and methanogens (Kobayashi et al. 1988). More often, in situ analyses (with fluorescently labeled antibodies) are used to detect the spatial distribution of certain microorganisms (Zellner et al. 1995; Kobayashi et al. 1988; Buswell et al. 1998; Coughlin et al. 1997; Sonne Hansen and Ahring 1997; Zellner et al. 1997; Stewart et al. 1997; Morin et al. 1996; Roberts and Keevil 1992; Hunik et al. 1993). Beside technical difficulties, such as nonspecific binding, the preparation of specific antibodies requires pure cultures. Consequently, the antibody technique is not really culture-independent, as only antibodies can be developed for organisms that can be cultivated.

With the nucleic acid approach, population analysis is possible without cultivation. Currently, most efforts are directed to the analysis of ribosomal RNA, recently reviewed by Schramm and Amann (1999). For several reasons, 16S RNA sequence analysis is a powerful tool for the classification of microorganisms (Woese 1987; Maidak et al. 1994). Ribosomes are present in all organisms; thus, this piece of genetic material is universal.

Part of the RNA molecules is identical for all microorganisms, while other regions are less well conserved. Thus, sequences can be found that are specific for different taxonomic levels, from species, genera, kingdoms, and domains. Public databases contain 16S RNA sequences from many of the described bacterial species. Microbial cells contain 1,000–30,000 copies of 16S RNA molecules, allowing sensitive assays and identification of single cells by fluorescent oligonucleotide hybridization.

Fingerprinting techniques for populations based on 16S rDNA analysis are ARDRA (amplified ribosomal DNA restriction analysis; Heyndrickx et al. 1996), DGGE (Muyzer and De Waal 1994) or TGGE (temperature gradient gel electrophoresis), and T-RFLP (terminal-restriction fragment length polymorphism; Liu et al. 1997). These techniques all involve isolation of DNA and amplification of the genes or gene fragments encoding for 16S RNA by PCR (polymerase chain reaction).

In the procedure of ARDRA and T-RFLP, first the complete 16S RNA genes are amplified by PCR; this is followed by a digestion with restriction enzymes and size separation of the fragments by gel electrophoresis. ARDRA is used for fast screening of isolates, particularly giving information on similarities. ARDRA is less suitable for community analysis because of the complexity of resulting band patterns. T-RFLP results in community fingerprints which can demonstrate the diversity and dynamics of microbial communities.

However, different species have often similar fragment lengths, leading to an underestimation of the diversity. The more sensitive alternatives are DGGE and TGGE (Schramm and Amann 1999).

For DGGE and TGGE, only fragments are amplified (200–500 bp) and a GC-rich sequence of 40 bp is added at one end. With an increasing gradient of DNA denaturing agents, denaturation of double-stranded to single-stranded DNA fragments will occur at a position in the gel that depends on the composition of the DNA fragment (G + C content, sequence). Upon denaturation, the migration of that gene fragment stops. Consequently, fragments of the same length but with different sequences can be effectively separated, resulting in a band pattern reflecting the microbial diversity of the community. The sensitivity of DGGE is ca. 1 %, meaning that bacterial populations making up 1 % or more of the total community can be detected (Muyzer and Smalla 1998). These methods (DGGE and TGGE) are very useful for detecting population changes of complex microbial communities. Bands in the gel can be further identified by hybridization analysis with specific probes (complementary fluorescently labeled DNA fragments). Also, bands can be retrieved from the gel and sequenced after amplification and cloning. Comparing the sequence with a database allows identification or affiliation of the band within a phylogenetic tree. Although molecular methods may suffer from biases, they are probably less biased than cultivation methods. DNA has to be extracted, and not all cells may lyse. Furthermore, preferential amplification of DNA during the PCR can occur, and consequently, the band intensity in DGGE gels must not be interpreted as a quantitative measure for species abundance (Schramm et al. 1998b). Quantitative analysis is possible with hybridization, either dot-blot hybridization (Stahl et al. 1988) or in situ hybridization (Amann 1995) with labeled oligonucleotide sequences targeting rRNA. After sequencing, it is possible to design a probe (with a fluorescent marker) targeting that sequence and use it for FISH. Then, by a combination of FISH with microscopic analysis and cell counting, quantitative analysis is possible of uncultivated, and even uncultivable, species in environmental samples.

Fluorescent in situ hybridization (FISH) is a recently developed, very powerful tool to quantify populations within a microbial community and to determine the spatial distributions of populations on different taxonomic levels. Instead of extracting nucleic acids, the cells are gently permeabilized so that fluorescently labeled 16S RNA probes, small fragments of up to 20 bp, can enter the cells and hybridize with rRNA. Probes can be labeled with different fluorescent dyes, each with distinct excitation and emission spectra. Thus, two or more probes can be used simultaneously to detect different (up to seven) populations within one sample (Amann et al. 1996). However, the spatial distribution of populations as determined with FISH does not give information on the activity of the cells. The populations detected are there but can be inactive or dead. Conversion rates can be derived from microprofiles determined with microsensors. At the moment,

the combination of in situ techniques, that is, molecular and microsensor techniques, gives the most accurate characterization of microbial interactions and activities in complex microbial communities.

References

- Ahring BK, Schmidt JE, Winther-Nielsen M, Macario AJL, Conway de Macario E (1993) Effect of medium composition and sludge removal on the production, composition and structure of thermophilic (55°C) acetate-utilizing granules from an upflow anaerobic sludge blanket reactor. *Appl Environ Microbiol* 59:2538–2545
- Allison DG, Evans DJ, Brown MRW, Gilbert P (1990) Possible involvement of the division cycle in dispersal of *Escherichia coli* biofilms. *J Bacteriol* 172:1667–1669
- Amann RI (1995) In situ identification of micro-organisms by whole cell hybridization with rRNA-targeted nucleic acid probes. *Molec Microbiol Ecol Man* 4:543–554
- Amann R, Snaird J, Wagner M, Ludwig W, Schleifer KH (1996) In situ visualisation of high genetic diversity in a natural microbial community. *J Bacteriol* 178:3496–3500
- Andreasen K, Nielsen PH (1997) Application of microautoradiography to the study of substrate uptake by filamentous microorganisms in activated sludge. *Appl Environ Microbiol* 63(9):3662–3668
- Arnold FH, Blanch HW, Wilke CR (1985) Analysis of affinity separations II: the characterization of affinity columns by pulse techniques. *Chem Eng J* 30:25–36
- Axelrod D, Koppel DE, Schlessinger J, Elson E, Webb WW (1976) Mobility measurement by analysis of fluorescence photobleaching recovery kinetics. *Biophys J* 16:1055–1069
- Bakke R, Trulear MG, Robinson JA, Characklis WG (1984) Activity of *Pseudomonas aeruginosa* in steady state biofilms. *Biotechnol Bioeng* 26:1418–1424
- Beefink HH, Staagaard P (1986) Structure and dynamics of anaerobic bacterial aggregates in a gas-lift reactor. *Appl Environ Microbiol* 52(5):1139–1146
- Beefink HH (1987) Anaerobic bacterial aggregates; variety and variation. University of Amsterdam, Amsterdam
- Beefink HH, van den Heuvel JC (1987) Novel anaerobic gas-lift reactor AGLR with retention of biomass, start-up routine and establishment of hold up. *Biotechnol Bioeng* 30(2):233–238
- Berg HC (1983) Random walks in biology. Princeton University Press, Princeton
- Berg P, Risgaard-Pedersen N, Rysgaard S (1998) Interpretation of measured concentration profiles in sediment pore water. *Limnol Oceanogr* 43(7):1500–1510
- Both GJ, Gerards S, Laanbroek HJ (1992) Temporal and spatial variation in the nitrite oxidising bacterial community of a grassland soil. *FEMS Microbiol Ecol* 101(2):99–102
- Boyd A, Chakrabarty AM (1994) Role of alginate lyase in cell detachment of *Pseudomonas aeruginosa*. *Appl Environ Microbiol* 60:2355–2359
- Boyer MB, Hsu JT (1992) Experimental studies of restricted protein diffusion in an agarose matrix. *Am Inst Chem Eng J* 38:259–272
- Bremer PJ, Geesey GG, Drake B (1992) Atomic force microscopy examination of the topography of a hydrated bacterial biofilm on a copper surface. *Curr Microbiol* 24:223–230
- Brenner H, Gaydos LJ (1977) The constrained brownian movement of spherical particles in cylindrical pores of compatible radius. *J Coll Interfac Sci* 58:312–356
- Brown MRW, Gilbert P (1993) Sensitivity of biofilms to antimicrobial agents. *J Appl Bacteriol Symp* 74(Suppl):87–97
- Bryers JD, Characklis WG (1981) Early fouling biofilm formation in a turbulent flow system: overall kinetics. *Wat Res* 15:483–491
- Bryers J, Drummond F (1996) Local macromolecule diffusion coefficients in structurally non-uniform bacterial biofilms using fluorescence recovery after photobleaching (FRAP). *Biotechnol Bioeng* 60(4):462–473
- Buffiere P, Steyer JP, Fonade C, Moletta R (1995) Comprehensive modeling of methanogenic biofilms in fluidized bed systems: mass transfer limitations and multisubstrate aspects. *Biotechnol Bioeng* 48:725–736

- Buret A, Ward KH, Olson ME, Costerton JW (1991) An in vivo model to study the pathobiology of infectious biofilms on biomaterial surfaces. *J Biomed Mat Res* 25(7):865–874
- Buswell CM, Herlihy YM, Lawrence LM, Mcguiggan JTM, Marsh PD, Keevil CW, Leach SA (1998) Extended survival and persistence of *Campylobacter* spp. in water and aquatic biofilms and their detection by immunofluorescent-antibody and-rRNA staining. *Appl Environ Microbiol* 64(2):733–741
- Caldwell DE, Lawrence JR (1988) Study of attached cells in continuous-flow slide culture. In: Wimpenny JWT (ed) *Handbook of laboratory model systems for microbial ecosystems*. CRC Press, Boca Raton, pp 117–138
- Camper AK (1994) Coliform regrowth and biofilm accumulation in drinking water systems: a review. In: Geesey GG, Lewandowski Z, Flemming HC (eds) *Biofouling/biocorrosion in industrial systems*. Lewis, Chelsea, pp 91–105
- Canfield DE, Des Marais DJ (1991) Aerobic sulfate reduction in microbial mats. *Science* 251:1471–1473
- Characklis WG. Biofouling: effects and control. In: *International workshop industrial biofilms biocorrosion*, pp 7–27
- Characklis WG (1988) Model biofilm reactors. In: Wimpenny JWT (ed) *Handbook of laboratory model systems for microbial ecosystems*. CRC Press, Boca Raton, pp 155–174
- Characklis WG (1990) Microbial fouling. In: Characklis WG, Marshall KC (eds) *Biofilms*. Wiley, New York, pp 523–584
- Characklis WG, Marshall K (1990) Biofilms: a basis for an interdisciplinary approach. In: Characklis WG, Marshall KC (eds) *Biofilms*. Wiley, New York, pp 3–15
- Chayen J, Bitensky L, Butcher R (1973) *Practical histochemistry*. Wiley, New York
- Chen C-I, Griebel T, Characklis WG (1993) Biocide action of monochloramine on biofilm systems of *Pseudomonas aeruginosa*. *Biofouling* 7:1–17
- Christensen BE, Characklis WG (1990) Physical and chemical properties of biofilms. In: Characklis WG, Marshall KC (eds) *Biofilms*. Wiley, New York, pp 93–130
- Cochran WL, McFeters GA, Stewart PS (2000) Reduced susceptibility of thin *Pseudomonas aeruginosa* biofilms to hydrogen peroxide and monochloramine. *J Appl Microbiol* 88:22–30
- Costerton WJ, Lewandowski ZL, Debeer D, Caldwell D, Korber D, James G (1994) Biofilms, the customized microniche. *J Bacteriol* 176(8):2137–2142
- Costerton JW, Stewart PS, Greenberg EP (1999) Bacterial biofilms: a common cause of persistent infections. *Science* 284:1318–1322
- Coughlin MF, Kinkle BK, Tepper A, Bishop PL (1997) Characterization of aerobic azo dye-degrading bacteria and their activity in biofilms. *Wat Sci Technol* 36(1):215–220
- Cronenberg CCH, Van Groen H, De Beer D, Van den Heuvel JC (1991) Oxygen-independent glucose microsensor based on glucose oxidase. *Anal Chim Acta* 242:275–278
- Cronenberg CCH (1994) *Biofilms investigated with needle-type glucose sensors*. University of Amsterdam, Amsterdam
- Cronenberg CCH, Ottengraf SPP, van den Heuvel JH, Pottel F, Sziele D, Schugler K, Bellgardt KH (1994) Influence of age and structure of *Penicillium chrysogenum* pellets on the internal concentration profiles. *Bioproc Engin* 10:209–216
- Csikor Z, Mihaltz P, Czako L, Hollo J (1994) New interpretation of expansion in biofilm-coated particle fluidization. *Appl Microbiol Biotechnol* 41:608–614
- Daffonchio D, Thaveeshi J, Verstraete W (1995) Contact angle measurement and cell hydrophobicity of granular sludge from UASB reactors. *Appl Environ Microbiol* 61(10):3676–3680
- Dalton HM, Goodman AE, Marshall KC (1996) Diversity in surface colonization behavior in marine bacteria. *J Ind Microbiol* 17:228–234
- Damgaard LR, Larsen LH, Revsbech NP (1995) Microscale biosensors for environmental monitoring. *Trends Anal Chem* 14:300–303
- Damgaard LR, Revsbech NP (1997) A microscale biosensor for methane. *Anal Chem* 69(13):2262–2267
- Davies DG, Geesey GG (1995) Regulation of the alginate biosynthesis gene *algC* in *Pseudomonas aeruginosa* during biofilm development in continuous culture. *Appl Environ Microbiol* 61(3):860–867
- Davies DG, Parsek MR, Pearson JP, Iglewski BH, Costerton JW, Greenberg EP (1998) The involvement of cell-to-cell signals in the development of a bacterial biofilm. *Science* 280:295–298
- De Beer D, van den Heuvel JC (1988) Response of ammonium-selective microelectrodes based on the neutral carrier nonactin. *Talanta* 35(9):728–730
- De Beer D, Sweerts JPRA (1989) Measurements of nitrate gradients with an ion-selective microelectrode. *Anal Chim Acta* 219:351–356
- De Beer D, Sweerts JPRA, van den Heuvel JC (1991) Microelectrode measurement of ammonium profiles in freshwater sediments. *FEMS Microbiol Ecol* 86(1):1–6
- De Beer D, van den Heuvel JC, Ottengraf SPP (1993) Microelectrode measurements of the activity distribution in nitrifying bacterial aggregates. *Appl Environ Microbiol* 59(2):573–579
- De Beer D, Srinivasan R, Stewart PS (1994a) Direct measurement of chlorine penetration into biofilms during disinfection. *Appl Environ Microbiol* 60(12):4339–4344
- De Beer D, Stoodley P, Lewandowski Z (1994b) Liquid flow in heterogeneous biofilms. *Biotechnol Bioeng* 44:636–641
- De Beer D, Stoodley P, Roe F, Lewandowski Z (1994c) Effect of biofilm structures on oxygen distribution and mass transfer. *Biotechnol Bioeng* 43:1131–1138
- De Beer D, Stoodley P (1995) Relation between the structure of an aerobic biofilm and transport phenomena. *Wat Sci Technol* 32(8):11–18
- De Beer D (1996) Microenvironments and mass transfer phenomena in biofilms and activated sludge studied with microsensors. In: *International symposium on environmental biotechnology*, Ostend Belgium, pp 217–224
- De Beer D, O'Flaherty V, Thaveeshi J, Lens P (1996) Distribution of extracellular polysaccharides and flotation of anaerobic sludge. *Appl Microbiol Biotechnol* 46:197–201
- De Beer D, Glud A, Epping E, Kühl M (1997a) A fast responding CO₂ microelectrode for profiling sediments, microbial mats and biofilms. *Limnol Oceanogr* 42(7):1590–1600
- De Beer D, Schramm A, Santegoeds CM, Kühl M (1997b) A nitrite microsensor for profiling environmental biofilms. *Appl Environ Microbiol* 63(3):973–977
- De Beer D, Stoodley P, Lewandowski Z (1997c) Measurement of local diffusion coefficients in biofilms by microinjection and confocal microscopy. *Biotechnol Bioeng* 53:151–158
- De Beer D, Kühl M (1998) Interfacial processes, gradients and metabolic activity in microbial mats and biofilms. In: Boudreau B, Jørgensen BB (eds) *The benthic boundary layer*. Oxford University Press, Oxford
- De Beer D, Schramm A, Santegoeds CM, Nielsen HK (1998) Anaerobic processes in activated sludge. *Wat Sci Technol* 37(4–5):605–608
- De Beer D (1999a) Use of microelectrodes to measure in situ microbial activities in biofilms, sediments and microbial mats. In: Akkermans ADL, van Elsas JD, de Bruijn FJ (eds) *Molecular microbial ecology manual*. Kluwer, Dordrecht
- De Beer D (1999b) *Micro-electrodes*. In: Wijffels R (ed) *Immobilized cells*. Springer, Heidelberg
- Decho AW (1990) Microbial exopolymer secretions in ocean environments: their role(s) in food webs and marine processes. *Oceanogr Mar Biol Ann Rev* 28:73–153
- Decho AW, Lopez GR (1993) Exopolymer microenvironments of microbial flora: multiple and interactive effects on trophic relationships. *Limnol Oceanogr* 38(8):1633–1645
- Eighmy TT, Maratea D, Bishop PL (1983) Electron microscopic examination of wastewater biofilm formation and structural components. *Appl Environ Microbiol* 45:1921–1931
- Elvers KT, Leeming K, Moore CP, Lappin-Scott HM (1998) Bacterial-fungal biofilms in flowing water photo-processing tanks. *J Appl Microbiol* 84:607–618
- Escher A, Characklis WG (1990) Modeling the initial events in biofilm accumulation. In: Marshall KC, Characklis WG (eds) *Biofilms*. Wiley, New York, pp 445–486
- Fattom A, Shilo M (1984) Hydrophobicity as an adhesion mechanism of benthic cyanobacteria. *Appl Environ Microbiol* 47:135–143
- Flemming HC (1998a) Extracellular polymeric substances-the key to understand biofilms. In: *First international workshop on biofilms in aerobic wastewater treatment: an interdisciplinary approach*, Garching, Germany, pp 28–30
- Flemming HC, Griebel T, Schaule G (1998) Antifouling strategies in technical systems: a short review. *Wat Sci Technol* 34(5–6):517–524

- Fowler HW (1988) Microbial adhesion to surfaces. In: Wimpenny JWT (ed) Handbook of laboratory model systems for microbial ecosystems. CRC Press, Boca Raton, pp 139–153
- Frolund B, Palmgren R, Keiding K, Nielsen PH (1996) Extraction of extracellular polymers from activated sludge using a cation exchange resin. *Wat Res* 30(8):1749–1758
- Frund C, Cohen Y (1992) Diurnal cycles of sulfate reduction under oxic conditions in Cyanobacterial mats. *Appl Environ Microbiol* 58(1):70–77
- Gjaltema A, Arts PAM, van Loosdrecht MCM, Kuenen JG, Heijnen JJ (1994) Heterogeneity of biofilms in rotating annular reactors: occurrence, structure, and consequences. *Biotechnol Bioeng* 44:194–204
- Gjaltema A, Tjihuis L, van Loosdrecht MCM, Heijnen JJ (1995) Detachment of biomass from suspended nongrowing spherical biofilms in airlift reactors. *Biotechnol Bioeng* 46(3):258–269
- Gjaltema A, Vinke JL, van Loosdrecht MCM, Heynen JJ (1997) Abrasion of suspended biofilm pellets in airlift reactors: importance of shape, structure, and particle concentrations. *Biotechnol Bioeng* 53:88–99
- Gorris LGM, van Deursen JMA, van der Drift C, Vogels GD (1988) Influence of waste water composition on biofilm development in laboratory methanogenic fluidized bed reactors. *Appl Microbiol Biotechnol* 29:95–102
- Greenberg EP (1997) Quorum sensing in gram-negative bacteria. *ASM News* 63(7):371–377
- Griebe T, Schaul G, Secker J, Flemming HC (1995) Bestimmung der stoffwechsellaktiven Bakterien im belebten Schlamm Wasser Abwasser 136(12):608–615
- Griebe T, Flemming HC (1998) Biocide-free antifouling strategy to protect RO membranes from biofouling. *Desalination* 118:153–157
- Gunning PA, Kirby AR, Parker ML, Gunning AP, Morris VJ (1996) Comparative imaging of *Pseudomonas putida* bacterial biofilms by scanning electron microscopy and both DC contact and AC non-contact atomic force microscopy. *J Appl Bacteriol* 81(3):276–282
- Haigler CH, Brown RM, Benzman M (1980) Calcofluor White ST alters the in vivo assembly of cellulose microfibrils. *Science* 210:903–906
- Hall-Stoodley L, Lappin-Scott HM (1998) Biofilm formation by the rapidly growing mycobacterial species *Mycobacterium fortuitum*. *FEMS Microbiol Lett* 168:77–84
- Hall-Stoodley L, Rayner JC, Stoodley P, Lappin-Scott HM (1999) Establishment of experimental biofilms using the modified Robbins device and flow cells. In: Edwards C (ed) *Methods in biotechnology*, vol 12, Environmental monitoring of bacteria. Humana Press, Totowa, pp 307–319
- Harada H, Eumura S, Momonoi K (1994) Interaction between sulfate reducing bacteria and methane-producing bacteria in UASB reactors fed with low strength wastes containing different levels of sulfate. *Wat Res* 28:355–367
- Harmer C, Bishop P (1992) Transformation of AZO dye AO-7 by waste water biofilms. *Wat Sci Technol* 26:627–636
- Haugland RP (1996) Handbook of fluorescent probes and research. Chemicals Molecular Probes Inc, Eugene
- Heijnen JJ (1984) Biological industrial waste-water treatment minimizing biomass production and maximizing biomass concentration. Technical University, Delft
- Heyndrickx HJM, Vauterin L, Vandamme P, Kersters K, De Vos P (1996) Applicability of combined ribosomal DNA restriction analysis (ARDRA) patterns in bacterial phylogeny and taxonomy. *J Microbiol Meth* 26:246–259
- Hinke J (1969) Glass microelectrodes for the study of binding and compartmentalisation of intracellular ions. In: Lavallee M, Schanne OF, Herbert NC (eds) *Glass microelectrodes*. Wiley, New York, pp 349–375
- Horn H, Hempel DC (1997) Substrate utilization and mass transfer in an autotrophic biofilm system: experimental results and numerical simulation. *Biotechnol Bioeng* 53(4):363–371
- Hsu Y, Shieh WK (1993) Startup of anaerobic fluidized bed reactors with acetic acid as the substrate. *Biotechnol Bioeng* 41:347–353
- Hulshoff Pol LW (1989) The phenomenon of anaerobic sludge. Wageningen Agricultural University, Wageningen
- Hunik JH, van den Hoogen MP, de Boer W, Smit M, Tramper J (1993) Quantitative determination of the spatial distribution of *Nitrosomonas europaea* and *Nitrobacter agilis* cells immobilized in kappa carrageenan gel beads by a specific fluorescent antibody labeling technique. *Appl Environ Microbiol* 59(6):1951–1954
- Jahn A, Nielsen PH (1995) Extraction of extracellular polymeric substances from biofilms using a cation exchange resin. *Wat Sci Technol* 32(8):157–164
- Jensen K, Revsbech NP, Nielsen LP (1993) Microscale distribution of nitrification activity in sediment determined with a shielded microsensor for nitrate. *Appl Environ Microbiol* 59(10):3287–3296
- Jeroschewski P, Steukart C, Kühl M (1996) An amperometric microsensor for the determination of H₂S in aquatic environments. *Anal Chem* 68:4351–4357
- Jørgensen BB, Revsbech NP (1985) Diffusive boundary layers and the oxygen uptake of sediments and detritus. *Limnol Oceanogr* 30(1):111–122
- Jørgensen BB, Des Marais D (1990) The diffusive boundary layer of sediments: oxygen microgradients over a microbial mat. *Limnol Oceanogr* 35:1343–1355
- Jørgensen BB (1994) Diffusion processes and boundary layers in microbial mats. In: Stal LJ, Caumette P (eds) *Microbial mats: structure, development and environmental significance*. Springer, Berlin, pp 243–253
- Karsten U, Kühl M (1996) Die Mikrobenmatte-das kleinste Ökosystem der Welt *Biologie Unserer Zeit* 26(1):16–26
- Klimant I, Kühl M, Glud RN, Holst G (1997) Optical measurements of oxygen and temperature in microscale: Strategies and biological applications. *Sens Actuators B* 38–39:29–37
- Kobayashi HA, De Macario EC, Williams RS, Macario AJL (1988) Direct characterization of methanogens in two high-rate anaerobic biological reactors. *Appl Environ Microbiol* 54(3):693–698
- Koehl MAR (1984) How benthic organisms withstand moving water. *Am Zool* 24:57–70
- Koster I (1989) Toxicity in anaerobic digestion. Wageningen Agricultural University, Wageningen
- Krekeler D, Sigalevich P, Teske A, Cypionka H, Cohen Y (1997) A sulfate reducing bacterium from the oxic layer of a microbial mat from Solar Lake (Sinai) *Desulfovibrio oxyclineae* sp. nov. *Arch Microbiol* 167(6):369–375
- Kugaprasatham S, Nagaoka H, Ohgaki S (1992) Effect of turbulence on nitrifying biofilms at non-limiting substrate conditions. *Wat Res* 26(12):1629–1638
- Kühl M, Jørgensen BB (1992) Microsensor measurements of sulfate reduction and sulfide oxidation in compact microbial communities of aerobic biofilms. *Appl Environ Microbiol* 58(4):1164–1174
- Kühl M, Revsbech NP (1998) Microsensors for the study of interfacial biogeochemical processes. In: Boudreau B, Jørgensen BB (eds) *The Benthic boundary layer*. Oxford University Press, Oxford
- Larsen LH, Revsbech N, Binnerup SJ (1996) A microsensor for nitrate based on immobilized denitrifying bacteria. *Appl Environ Microbiol* 62(4):1248–1251
- Larsen LH, Kjaer T, Revsbech NP (1997) A microscale NO₃-biosensor for environmental applications. *Anal Chem* 69(17):3527–3531
- Lauwers AM, Heijnen W, Gorris LGM, van der Drift C (1990) Early stages in biofilm development in methanogenic fluidized-bed reactors. *Appl Microbiol Biotechnol* 33:352–358
- Lawrence JR, Korber DR, Hoyle BD, Costerton JW, Caldwell DE (1991) Optical sectioning of microbial biofilms. *J Bacteriol* 173(20):6558–6567
- LeChevallier MW, Lowry CD, Lee RG (1988) Inactivation of biofilm bacteria. *Appl Environ Microbiol* 54:2492–2499
- Lee W, de Beer D (1995) Oxygen and pH microprofiles above corroding mild steel covered with a biofilm. *Biofouling* 8:273–280
- Lens PN, De Poorter M-P, Cronenberg CC, Verstraete WH (1995) Sulfate reducing and methane producing bacteria in aerobic wastewater treatment systems. *Wat Res* 29(3):871–880
- Lettinga G (1995) Anaerobic digestion and wastewater treatment. *Ant v Leeuwenhoek* 67:3–28
- Lewandowski Z, Walser G (1991) Influence of hydrodynamics on biofilm accumulation. In: *Proceedings of the American Society of Civil Engineers, Environmental Engineering Division*, Reno, pp 619–624
- Lewandowski Z, Walser G, Characklis WG (1991) Reaction kinetics in biofilms. *Biotechnol Bioeng* 38:877–882
- Lewandowski Z, Altobelli SA, Fukushima E (1993) NMR and microelectrode studies of hydrodynamics and kinetics in biofilms. *Biotechnol Prog* 9:40–45
- Libicki SB, Salmon PM, Robertson CR (1988) The effective diffusive permeability of a nonreacting solute in microbial cell aggregates. *Biotechnol Bioeng* 32:68–85
- Little B, Wagner P, Ray R, Pope R, Scheetz R (1991) Biofilms, an ESEM evaluation of artifacts introduced during preparation. *J Ind Microbiol* 8(4):213–222

- Liu WT, Marsh TL, Forney LJ (1997) Determination of the microbial diversity of anaerobic-aerobic activated sludge by a novel molecular biological technique. In: 2nd international conference on microorganisms in activated sludge and biofilm processes, Berkeley CA, pp 247–254
- Mack WN, Mack JP, Ackerson AO (1975) Microbial film development in trickling filters. *Microb Ecol* 2:215–316
- Maidak BL, Larsen N, McCaughey MJ, Overbeek R, Olsen GJ, Fogel K, Blandy J, Woese CR (1994) The ribosomal database project. *Nucleic Acids Res* 22:3485–3487
- Massol-Deya AA, Whallon J, Hickey RE, Tiedje JM (1995) Channel structure in aerobic biofilms of fixed-film reactors treating contaminated groundwater. *Appl Environ Microbiol* 61(2):769–777
- Maximilien R, de Nys R, Holmstrom C, Gram L, Crass K, Kjelleberg S, Steinberg PD (1998) Chemical mediation of bacterial surface colonisation by secondary metabolites from the red alga *Delisa pulchra*. *Aquat Microb Ecol* 15(3):233–246
- McCoy WF, Bryers JD, Robbins J, Costerton JW (1981) Observations of fouling biofilm formation. *Can J Microbiol* 27:910–917
- McCoy WF (1987) Effects of fouling biofilms on systems performance. In: Mittelman MW, Geesey GG (eds) *Biological fouling of industrial water systems: a problem solving approach*. Water Micro Associates, San Diego, pp 234–246
- Møller S, Korber DR, Wolfaardt GM, Molin S, Caldwell DE (1997) Impact of nutrient composition on a degradative biofilm community. *Appl Environ Microbiol* 63:2432–2438
- Morck DW, Lam K, McKay SG, Olson ME, Prosser B, Ellis BD, Cleland R, Costerton JW (1994) Comparative evaluation of fleroxacin, ampicillin, trimethoprim-sulfamethoxazole, and gentamicin as treatments of catheter-associated urinary tract infection in a rabbit model. *Int J Antimicrob Agents* 4(2):521–527
- Morin P, Camper A, Jones W, Gatel D, Goldman JC (1996) Colonization and disinfection of biofilms hosting coliform-colonized carbon fines. *Appl Environ Microbiol* 62(12):4428–4432
- Müller B, Buis K, Stierli R, Wehrli B (1998) High spatial resolution measurements in lake sediments with PVC based liquid membrane ion-selective electrodes. *Limnol Oceanogr* 43(7):1728–1733
- Muyzer G, de Waal EC (1994) Determination of the genetic diversity of microbial communities using DGGE analysis of PCR-amplified 16S rDNA. *NATO ASI Series, G35*, pp 207–214
- Muyzer G, Smalla K (1998) Application of denaturing gradient gel electrophoresis (DGGE) and temperature gradient gel electrophoresis (TGGE) in microbial ecology. *Ant v Leeuwenhoek* 73:127–141
- Neu T, Lawrence JR (1997) Development and structure of microbial biofilms in river water studied by confocal laser scanning microscopy. *FEMS Microbiol Ecol* 24:11–25
- Nichols PH (1988) Susceptibility of biofilms to toxic compounds. In: Characklis WG, Wilderer PA (eds) *Structure and function of biofilms*. Wiley, New York, pp 321–331
- Nielsen PH, Frolund B, Keiding K (1996) Changes in composition of extracellular polymeric substances in activated sludge during anaerobic storage. *Appl Microbiol Biotechnol* 44(6):823–830
- Nielsen PH, Jahn A, Palmgren R (1997) Conceptual model for production and composition of exopolymers in biofilms. *Wat Sci Technol* 36(1):11–19
- Nielsen PH, Andreasen K, Wagner M, Blackall LL, Lemmer H, Seviour RJ (1998) Variability of type 021N in activated sludge as determined by in situ substrate uptake pattern and in situ hybridization with fluorescent rRNA targeted probes. *Wat Sci Technol* 37(4–5):423–430
- Okabe S, Hirata K, Ozawa Y, Watanabe Y (1996a) Spatial microbial distributions of nitrifiers and heterotrophs in mixed population biofilms. *Biotechnol Bioeng* 50:24–35
- Okabe S, Ozawa Y, Hirata K, Watanabe Y (1996b) Relationship between population dynamics of nitrifiers in biofilms and reactor performance at various C:N ratios. *Wat Res* 30(7):1563–1572
- Okabe S, Yasuda T, Watanabe Y (1997) Uptake and release of inert fluorogenic particles by mixed-population biofilms. *Biotechnol Bioeng* 53(5):459–469
- Overmeire A, Lens P, Verstraete W (1994) Mass transfer limitation of sulfate in methanogenic aggregates. *Biotechnol Bioeng* 44:387–391
- Paterson DM (1995) Biogenic structure of early sediment fabric visualized by low-temperature scanning electron microscopy. *J Geol Soc Lond* 152:131–140
- Peters A, Wimpenny JWT (1988) A constant depth laboratory model film fermenter. In: Wimpenny WT (ed) *Handbook of laboratory model systems for microbial ecosystems*. CRC Press, Boca Raton, pp 175–195
- Picologlou BF, Zveler N, Characklis WG (1980) Biofilm growth and hydraulic performance. *J Hydraulic Div Am Soc Civ Eng* 106(HY5):733–746
- Ploug H, Kühl M, Buchholz-Cleven B, Jørgensen BB (1997) Anoxic aggregates— an ephemeral phenomenon in the pelagic environment? *Aquat Microb Ecol* 13:285–294
- Ploug H, Jørgensen BB (1998) A net-jet flow system for mass transfer and microsensor studies of sinking aggregates. *Mar Ecol Prog Ser* 176:270–290
- Qian Z, Stoodley P, Pitt WG (1996) Effect of low-intensity ultrasound upon biofilm structure from confocal scanning microscopy observation. *Biomaterials* 17:1975–1980
- Ramsing NB, Kühl M, Jørgensen BB (1993) Distribution of sulfate-reducing bacteria, O₂, and H₂S in photosynthetic biofilms determined by oligonucleotide probes and microelectrodes. *Appl Environ Microbiol* 59:3840–3849
- Rasmussen K, Lewandowski Z (1998) Microelectrode measurements of local mass transport rates in heterogeneous biofilms. *Biotechnol Bioeng* 59(3):303–309
- Revsbech NP, Jørgensen BB (1983) Photosynthesis of benthic microflora measured with high spatial resolution by the oxygen microprofile method: capabilities and limitations of the method. *Limnol Oceanogr* 28(4):749–756
- Revsbech NP, Ward DM (1983) Oxygen microelectrode that is insensitive to medium chemical composition: use in an acid microbial mat dominated by *Cyanidium caldarum*. *Appl Environ Microbiol* 45:755–759
- Revsbech NP, Jørgensen BB, Blackburn TH, Cohen Y (1983) Microelectrode studies of the photosynthesis and O₂, H₂S and pH profiles of a microbial mat. *Limnol Oceanogr* 28(6):1062–1074
- Revsbech NP, Jørgensen BB (1986) Microelectrodes: their use in microbial ecology. *Adv Microbial Ecol* 9:293–352
- Revsbech NP, Madsen B, Jørgensen BB (1986) Oxygen production and consumption in sediments determined at high spatial resolution by computer simulation of oxygen microelectrode data. *Limnol Oceanogr* 31(2):293–304
- Revsbech NP, Nielsen LP, Christensen PB, Sørensen J (1988) A combined oxygen and nitrous oxide microsensor for denitrification studies. *Appl Environ Microbiol* 45:2245–2249
- Revsbech NP (1989) An oxygen microelectrode with a guard cathode. *Limnol Oceanogr* 34:1907–1910
- Revsbech NP, Nielsen LP, Ramsing NB (1998) A novel microsensor for determination of apparent diffusivity in sediments. *Limnol Oceanogr* 43(5):986–992
- Rittmann BE, Manem JA (1992) Development and experimental evaluation of a steady-state, multispecies biofilm model. *Biotechnol Bioeng* 39:914–922
- Roberts J, Keevil CW (1992) Immunogold and fluorescein immunolabelling of *Legionella pneumophila* within an aquatic biofilm visualized by using episcopic differential interference contrast microscopy. *Appl Environ Microbiol* 58(7):2326–2330
- Robinson RW, Akin DE, Nordstedt RA, Thomas MV, Aldrich HC (1984) Light and electron microscopic examinations of methane producing biofilms from anaerobic fixed bed reactors. *Appl Environ Microbiol* 48(1):127–136
- Rodbard D, Chranbach A (1970) Unified theory for gel electrophoresis and gel filtration. *Proc Natl Acad Sci USA* 65:970–977
- Sanden B, Grunditz C, Hansson Y, Dalhammar G (1994) Quantification and characterization of Nitrosomonas and Nitrobacter using monoclonal antibodies. *Wat Sci Technol* 29(7):1–6
- Sanford BA, Thomas VL, Mattingly SJ, Ramsay MA, Miller MM (1995) Lectin-biotin assay for slime present in in situ biofilm produced by *Staphylococcus epidermidis* using transmission electron microscopy (TEM). *J Ind Microbiol* 15(3):156–161
- Santegoeds CM, Ferdeman TG, Muyzer G, de Beer D (1998) Structural and functional dynamics of sulfate-reducing populations in bacterial biofilms. *Appl Environ Microbiol* 64(11):3731–3739
- Santegoeds CM (1999) Structure and function analysis of sulfate reducing communities in wastewater treatment systems. A combined molecular and microsensor study. Bremen University, Bremen
- Santegoeds CM, Damgaard LR, Hesselink G, Zopfi J, Lens P, Muyzer G, de Beer D (1999) Distribution of sulfate reducing and methanogenic bacteria

- in anaerobic aggregates determined by microsensor and molecular techniques. *Appl Environ Microbiol*
- Schmidt JE, Ahring BK (1994) Extracellular polymers in granular sludge from different upflow anaerobic sludge blanket (UASB) reactors. *Appl Microbiol Biotechnol* 42:457–462
- Schopf JW, Klein C (1992) The proterozoic biosphere: a multidisciplinary study. Cambridge University Press, New York
- Schramm A, Larsen LH, Revsbech NP, Ramsing NB, Amann R, Schleifer K-H (1996) Structure and function of a nitrifying biofilm as determined by in situ hybridization and the use of microelectrodes. *Appl Environ Microbiol* 62:4641–4647
- Schramm A (1998) In situ structure and function analysis of nitrifying/denitrifying biofilms. Bremen University, Bremen
- Schramm A, de Beer D, van den Heuvel H, Ottengraf SPP, Amann R (1998a) In situ structure/function studies in wastewater treatment systems. *Wat Sci Technol* 37(4–5):413–416
- Schramm A, de Beer D, Wagner M, Amann R (1998b) Nitrospira and Nitrospira sp. as dominant populations in a nitrifying fluidized bed reactor: identification and activity in situ. *Appl Environ Microbiol* 64(9):3480–3485
- Schramm A, Amann R (1999) Nucleic acid based techniques for analyzing the diversity, structure, and dynamics of microbial communities in wastewater treatment. In: Winter J (ed) *Environmental processes: wastewater and waste treatment*. Wiley-VCH, Weinheim, pp 1–24
- Schulthess P, Shijo Y, Pham HV, Pretsch E, Ammann D, Simon W (1981) A hydrogen ion-selective liquid-membrane electrode based on tri-n-dodecylamine as neutral carrier. *Anal Chim Acta* 131:111–116
- Shaw DA, Hanratty TJ (1977) Turbulent mass transfer to a wall for large Schmidt numbers. *Amer Inst Chem Eng J* 23:28–37
- Shieh WK, Hsu Y (1996) Biomass loss from an anaerobic fluidized bed reactor. *Wat Res* 39(5):1253–1257
- Siebel MA, Characklis WG (1990) Observations of binary biofilms. *Biotechnol Bioeng* 37:778–789
- Siegrist H, Gujer W (1985) Mass transfer mechanisms in a heterotrophic biofilm. *Wat Res* 19:1369–1378
- Sly LI, Hodgkinson MC, Arunpairojana V (1990) Deposition of manganese in a drinking water distribution system. *Appl Environ Microbiol* 56(3):628–639
- Sonne Hansen J, Ahring BK (1997) Anaerobic microbiology of an alkaline Icelandic hot spring. *FEMS Microbiol Ecol* 23(1):31–38
- Späth R, Flemming HC, Würtz S (1998) Sorption properties of biofilms. *Wat Sci Technol* 37(4–5):207–210
- Stahl DA, Flesher B, Mansfield HR, Montgomery L (1988) Use of phylogenetically based hybridization probes for studies of ruminal ecology. *Appl Environ Microbiol* 54:1079–1084
- Staley JT, Konopka A (1985) Measurement of in situ activities of nonphotosynthetic microorganisms in aquatic and terrestrial habitats. *Ann Rev Microbiol* 39:321–346
- Stewart PS, Drury WJ, Murga R (1993) Quantitative observations of heterogeneities in *Pseudomonas aeruginosa* biofilms. *Appl Environ Microbiol* 59(1):327–329
- Stewart PS, Murga R, Srinivasan R, de Beer D (1995) Biofilm structural heterogeneity visualized by three microscopic methods. *Wat Res* 29(8):2006–2009
- Stewart PS, Hamilton MA, Goldstein BR, Schneider BT (1996) Modeling biocide action against biofilms. *Biotechnol Bioeng* 49:445–455
- Stewart PS, Camper AK, Handran SD, Huang CT, Warnecke M (1997) Spatial distribution and coexistence of *Klebsiella pneumoniae* and *Pseudomonas aeruginosa* in biofilms. *Microb Ecol* 33(1):2–10
- Stewart PS (1998) A review of experimental measurements of effective diffusive permeabilities and effective diffusion coefficients in biofilms. *Biotechnol Bioeng* 59(3):261–272
- Stoodley P, de Beer D, Lewandowski Z (1994) Liquid flow in biofilm systems. *Appl Environ Microbiol* 60:2711–2716
- Stoodley P, de Beer D, Lappin-Scott HM (1997) Influence of electric fields and pH on the biofilm structure as related to the bioelectric effect. *Antimicrob Agents Chemother* 41(9):1876–1879
- Stoodley P, Lewandowski Z, Boyle J, Lappin-Scott HM (1998) Oscillation characteristics of biofilm streamers in turbulent flowing water as related to drag and pressure drop. *Biotechnol Bioeng* 57(5):536–544
- Stoodley P, Dodds I, Boyle JD, Lappin-Scott HM (1999a) Influence of hydrodynamics and nutrients on biofilm structure. *J Appl Microbiol* 85:198–288
- Stoodley P, Jørgensen F, Williams P, Lappin-Scott HM (1999b) The role of hydrodynamics and AHL signalling molecules as determinants of the structure of *Pseudomonas aeruginosa* biofilms. In: Bayston R, Brading M, Gilbert P, Walker J, Wimpenny JWT (eds) *Biofilms: the good, the bad, and the ugly*. BioLine, Cardiff, pp 323–330
- Stoodley P, Lewandowski Z, Boyle JD, Lappin-Scott HM (1999c) Structural deformation of bacterial biofilms caused by short term fluctuations in flow velocity: an in-situ demonstration of biofilm viscoelasticity. *Biotechnol Bioeng* 65:83–92
- Stoodley P, Lewandowski Z, Boyle JD, Lappin-Scott HM (1999d) The formation of migratory ripples in a mixed species bacterial biofilm growing in turbulent flow. *Environ Microbiol* 1:447–457
- Surman SB, Walker JT, Goddard DT, Morton LHG, Keevil CW, Weaver W, Skinner A, Hanson K, Caldwell D, Kurtz J (1996) Comparison of microscope techniques for the examination of biofilms. *J Microbiol Meth* 25(1):57–70
- Sutherland IW (1994) Structure-function relationships in microbial exopolysaccharides. *Biotech Adv* 12:393–447
- Sutherland IW (1996) A natural terrestrial biofilm. *J Ind Microbiol* 17:281–283
- Sweerts J-PRA, de Beer D (1989) Microelectrode measurements of nitrate gradients in the littoral and profundal sediments of a meso-eutrophic lake (lake Vechten, The Netherlands). *Appl Environ Microbiol* 55(3):754–757
- Thaveeshi J, Daffonchio D, Liessens B, Vandermeren P, Verstraete W (1995) Granulation and sludge bed stability in UASB reactors in relation to surface thermodynamics. *Appl Environ Microbiol* 61(10):3681–3686
- Thomas RC (1978) Ion-sensitive intracellular microelectrodes, how to make and use them. Academic, London
- Tijhuis L, van Benthum WAJ, van Loosdrecht MCM, Heijnen JJ (1994a) Solids retention time in spherical biofilms in a biofilms airlift suspension reactor. *Biotechnol Bioeng* 59:867–879
- Tijhuis L, van Loosdrecht MCM, Heijnen JJ (1994b) Formation and growth of heterotrophic aerobic biofilms on small suspended particles in airlift reactors. *Biotechnol Bioeng* 44:595–608
- Tijhuis L, Hijman B, van Loosdrecht MCM, Heijnen JJ (1996) Influence of detachment, substrate loading and reactor scale on the formation of biofilms in airlift reactors. *Appl Microbiol Biotechnol* 45:7–17
- Torsvik V, Goksoyr J, Daae FL (1990) High diversity in DNA of soil bacteria. *Appl Environ Microbiol* 56:782–787
- Tsien RY, Rink TJ (1981) Ca^{2+} -selective electrodes: A novel PVC-gelled neutral carrier mixture compared with other currently available sensors. *J Neurosci Meth* 4:73–86
- Van Der Kooij D, Vrouwenvelder HS, Veenendaal HR (1995) Kinetic aspects of biofilm formation on surfaces exposed to drinking water. *Wat Sci Technol* 32(8):61–65
- Van Houten RT, Hulshoff Pol LW, Lettinga G (1994) Biological sulphate reduction using gas-lift reactors fed with hydrogen and carbon dioxide as energy and carbon source. *Biotechnol Bioeng* 44:586–594
- Van Loosdrecht MCM, Lyklema J, Norde W, Zehnder AJB (1990) Influence of interfaces on microbial activity. *Microbiol Rev* 54(1):75–87
- Van Loosdrecht MCM, Eikelboom D, Gjaltema A, Mulder A, Tijhuis L, Heijnen JJ (1995) Biofilm structures. *Wat Sci Tech* 32:35–43
- van Loosdrecht MCM, Picioreanu C, Heijnen JJ (1997) A more unifying hypothesis for biofilm structures. *FEMS Microbiol Ecol* 24:181–183
- Vogel S (1994) *Life in moving fluids*, 2nd edn. Princeton University Press, Princeton
- Wagner M, Amann R, Lemmer D, Schleifer K-H (1993) Probing activated sludge with oligonucleotides specific for proteobacteria: Inadequacy of culture-dependant methods for describing microbial community structure. *Appl Environ Microbiol* 59(5):1520–1525
- Wagner M, Armus B, Hartmann A, Hutzler P, Amann R (1994) In situ analysis of microbial consortia in activated sludge using fluorescently labelled, rRNA-targeted oligonucleotide probes and confocal scanning laser microscopy. *J Microscopy* 176(3):181–187
- Wanner O, Gujer W (1986) A multispecies biofilm model. *Biotechnol Bioeng* 28:314–328
- Wanner O, Reichert P (1996) Mathematical modeling of mixed culture biofilms. *Biotechnol Bioeng* 49:172–184

- Wayne LG, Brenner DJ, Colwell RR, Grimont PAD, Kandler O, Krichevsky MI, Moore C, Moore WEC, Murray RGE, Stackebrandt E, Starr MP, Trüper HG (1987) Report of the ad hoc committee on reconciliation of approaches to bacterial systematics. *Int J Syst Bacteriol* 37:463–464
- Westrin BA (1991) Diffusion measurements in gels. University of Lund, Lund
- Whiteley M, Brown E, McLean RJC (1997) An inexpensive chemostat apparatus for the study of microbial biofilms. *J Microbiol Meth* 30(2):125–132
- Widdel F (1988) Microbiology and ecology of sulfate and sulfur reducing bacteria. In: Zehnder ADJ (ed) *Biology of anaerobic microorganisms*. Wiley, New York, pp 469–585
- Wieland K (1999) Microsensor analysis of oxygen and sulfide turnover in hypersaline microbial mats. Bremen University, Bremen
- Wilderer PA, Characklis WG (1989) Structure and function of biofilms. In: Characklis WG, Wilderer PA (eds) *Structure and function of biofilms*. Wiley, New York, pp 5–17
- Williams JW, Wimpenny JWT (1978) Exopolysaccharide production by *Pseudomonas* NCIB 11264 grown in continuous culture. *J Gen Microbiol* 104:47–57
- Wimpenny JWT (1996) Development of a steady state oral microbial biofilm community using the constant depth film fermenter. *Microbiology* 142(3):631–638
- Woese CR (1987) Bacterial evolution. *Microbiol Rev* 51(2):221–271
- Wolfaardt GM, Lawrence JR, Robarts RD, Caldwell DE (1995) Bioaccumulation of the herbicide diclofop in extracellular polymers and its utilization by a biofilm community during starvation. *Appl Environ Microbiol* 61:152–158
- Wolfaardt GM, Lawrence JR, Robarts RD, Caldwell DE (1998) In situ characterization of biofilm exopolymers involved in the accumulation of chlorinated organics. *Microb Ecol* 35:213–223
- Xu X, Stewart PS, Chen X (1995) Transport limitation of chlorine disinfection of *Pseudomonas aeruginosa* entrapped in alginate beads. *Biotechnol Bioeng* 49:93–100
- Yang S, Lewandowski Z (1995) Measurement of local mass transfer coefficient in biofilms. *Biotechnol Bioeng* 48:737–744
- Zellner G, Feuerhake E.H-J, Macario AJL, Conway De Macario E (1995) Denitrifying and methanogenic bacteria in the biofilm of a fixed-film reactor operated with ethanol-nitrate demonstrated by immunofluorescence and microscopy *Appl. Microbiol. Biotechnol.* 43(5) 566–571
- Zellner G, Macario AJL, Conway De Macario E (1997) A study of three anaerobic methanogenic bioreactors reveals that syntrophs are diverse and different from reference organisms. *FEMS Microbiol Ecol* 22(4):295–301
- Zhang TC, Bishop PL (1994) Density, porosity, and pore structure of biofilms. *Wat Res* 28:2267–2277
- Zhang TC, Fu YC, Bishop PL (1994) Competition in biofilms. *Wat Environ Res* 67(6):992–1003
- Zhang TC, Bishop PL (1996) Evaluation of microelectrode performance and applicability in biofilm systems. In: 69th annual conference water environment federation, Dallas TX, pp 967–2007

14 Biofuels

Stefano Freguia¹ · Bernardino Viridis¹ · Korneel Rabaey^{1,2}

¹Advanced Water Management Centre, The University of Queensland, Brisbane, Australia

²Laboratory of Microbial Ecology and Technology (LabMET), Ghent University, Ghent, Belgium

Introduction	373
Feedstocks for Bioproduction: Three Generations	374
Pure Culture Bioproduction	374
<i>Zymomonas mobilis</i> : Fermentation of Sugars to Ethanol	375
Modified <i>Escherichia coli</i> : Fermentation of Sugars to Ethanol	375
<i>Clostridium phytofermentans</i> and <i>Clostridium</i> <i>acetobutylicum</i> : Hydrolysis of Polysaccharides and Fermentation of Formed Monosaccharides to Ethanol	375
<i>Corynebacterium glutamicum</i> : Fermentation of Sugars from Woody Biomass	376
Thermophilic Pure Cultures: Simultaneous Enzymatic Hydrolysis and Fermentation	376
Purple Non-Sulfur Bacteria: Photo-Fermentative Hydrogen Production	376
Mixed Culture Bioproduction	377
Biomethanation	377
Biological Hydrogen Production	378
Light-Driven Biodiesel	378
Novel Concepts	379
Syngas Fermentations to Bioalcohols	379
Direct Photosynthetic Conversion of CO ₂ to Bioalcohols	379
Perspectives	379

Abstract

Increasing pressure to move towards energy sustainability and reduce society's dependence on fossil fuels has led to much research and development in the area of biofuels. First-generation biofuel production (e.g., ethanol from corn) is a mature technology, but competition with food crops raises questions about sustainability. Second-generation biofuels are produced from waste biomass and thus are perceived as more viable, but technology is not ready for large-scale implementation particularly due to the hydrolysis challenge. The third generation of biofuels captures sunlight directly as fuels or fuel precursors via photosynthesis. Prokaryotic organisms play a crucial role in the majority of the processes involved in biofuel production. Pure

culture bioproduction includes ethanol from *Zymomonas mobilis*, modified *Escherichia coli*, and *Clostridia*. However, pure cultures are only efficient at the conversion of sugary biomass, not lignocellulosic biomass. They have thus limited applicability towards second-generation biofuel production. Pure culture prokaryotic biodiesel production is also being investigated (mostly using cyanobacteria). However, similarly to eukaryotic biodiesel production, energy efficiencies are still poor. Mixed culture production is thus far the most successful process at converting complex waste biomass to usable fuels, mainly methane through anaerobic digestion, which is perceived by many as the biofuel technology with highest potential.

Introduction

Transportation fuels are at present predominantly derived from fossil fuels. There are several types depending on the application. Road transport makes use of gasoline (C₄-C₁₂ alkanes as well as cycloalkanes and alkenes) or diesel (C₈-C₂₁ alkanes as well as naphthalenes and alkylbenzenes). Maritime transport rather uses the highly viscous “bunker fuel,” while aviation fuel requires a higher quality, and thus typically, a diesel-like kerosene or naphtha-kerosene blend is used. In the past decades, it has become apparent that fossil fuel reserves are gradually depleting and that their consumption is causing an imbalance on the global CO₂ budget. For this reason, a series of alternative energy sources for transportation have been considered. Electricity as source for road transportation is making rapid progress, and, for example, Li/ion batteries are getting to a stage of commercial viability (Axsen et al. 2010). Life cycle analysis has shown that electricity-driven transport can be more environmentally sound than liquid fuels, whatever their origin (Campbell et al. 2009). Key disadvantages of electricity as transport energy source are the requirement for an expanded electricity grid, the need for more sustainable electricity sources (now predominantly coal), and the limited radius for electricity-driven cars at present. There have been concerns regarding lithium availability, although it appears that not the availability but rather the cost depending on the lithium source is the key concern (Evans 2009). Also, it appears unlikely that electricity can be used for aviation or maritime transport, highlighting that there is a continuing need for storable gaseous or liquid fuels.

Already a range of gaseous fuels is considered for transportation. *Liquid petroleum gas* (LPG, propane, or butane) and *natural gas* (methane) are available. As will be discussed later

in this review, increasingly methane can be derived from microbial decomposition of waste organics, positioning this fuel as potentially the most sustainable, available fuel of the moment albeit with insufficient supply to accommodate the fuel demand (Tilche and Galatola 2008). Also for several decades on the horizon is hydrogen gas, which can be converted via a fuel cell at high energetic efficiency. The development of fuel cells has been complex, and thus far, there is a strong dependency on platinum, an expensive and unsustainable catalyst. Moreover, hydrogen cannot be compressed sufficiently to achieve high storage density, and thus, sorption matrices need development to improve the energy storage per unit volume.

The above outline highlights the need for liquid transportation fuels, particularly for the aviation and maritime transport applications. Already well established is the use of ethanol typically as blend-in fuel (E5 or E10). A whole range of other biofuels is on the horizon, produced via chemical, physicochemical, or biological means. This review focuses on the role of prokaryotes in the production of biofuels. Prokaryotes are highly versatile catalysts for the production of both specialty and bulk biochemicals, and the present need for liquid biofuels gives major impetus to research on prokaryotic biofuel production. We will discuss the known feedstocks for biofuel production, production via pure cultures and microbial populations, and light-driven biodiesel generation. Finally, perspectives for prokaryote research and development in this field will be provided.

Feedstocks for Bioproduction: Three Generations

Biofuels are generally categorized in three generations, although some biofuels can be produced in several generations. First-generation biofuels are produced from dedicated crops via traditional means of production. This implies that, for example, rape seed is grown to produce an oil that is the basis for biodiesel production (after transesterification). The key example visible to the consumer is corn-derived ethanol. In several stages, corn kernels are mashed, boiled, and fermented using organisms such as *Saccharomyces cerevisiae* and *Zymomonas mobilis* (Zhang et al. 1995). Key disadvantages of crop-based biofuels are the low yield per hectare of usable feedstock and competition with food production. For this reason, in recent times, second-generation biofuels have been increasingly studied. These fuels are produced from cellulosic or waste biomass, which requires more complex production processes but does not lead to the aforementioned issues that crop-based biofuels have. Key feedstocks here are sludge, corn stover, switchgrass, and waste biomass such as bagasses. Disadvantages of second-generation biofuels are the need for increased biomass processing and the often scattered availability. The latter relates to an existing economy of scale for biofuel production, rendering small local plants economically less competitive.

At a production level, the feedstock strongly determines the required conversion processes. While corn conversion to ethanol can rely on rapid hydrolysis and fermentation, corn stover

conversion will require extended hydrolysis of the (ligno) cellulosic material. For the hydrolysis, typically physicochemical or enzymatic methods are being used; for details on this topic we refer to a review by Kumar (Kumar et al. 2009). Thus far, no prokaryotes have been found to degrade lignocellulosic material at sufficiently high rates for application (with the exception of hydrolysis of biomass for biogas production).

Finally, the third-generation biofuels is produced directly from CO₂ and sunlight via photosynthesis. Major research efforts are directed to the use of algae or cyanobacteria for the direct production of (bio)diesel and secondary products from CO₂. Whereas this approach does not compete with arable land, there are restrictions relating to CO₂ availability (production facilities need to be in the vicinity of a major CO₂ source such as a power station), product yield, and nutrient requirement (Clarens et al. 2010).

The below table provides an overview of common feedstocks as well as target biofuels (► [Table 14.1](#)).

Pure Culture Bioproduction

Pure cultures of prokaryotes are often preferred to mixed populations for the fermentative production of bioalcohols and biohydrogen, as these bioreactions are highly organism-specific and typically not the preferred fermentation pathways in a mixed community. Mixed culture fermentation of glucose often leads to a mixture of fatty acids, typically comprising acetate as the main product due to the larger energy gain for the microorganisms (Madigan et al. 2000). In mixed cultures, any ethanol produced is likely to be further fermented to fatty acids in a syntrophic fashion, whereas any hydrogen is most likely used by archaeal populations to make methane. Considering this, any biofuel that requires a specific fermentation appears best served by a pure culture.

Many bacterial species such as *Zymomonas* (Zhang et al. 1995) and *Clostridium* have been used for fermentative biofuel production from sugars, and using systems biology, the yields are further improved. Genetically engineered microorganisms have been created to either introduce/enhance alcohol fermentation pathways, to improve the versatility toward different substrates or to alter the product outcomes. The aforementioned versatility is particularly important when lignocellulosic biomass is used as biofuel source. The hydrolysis of thermochemically pretreated lignocellulosic matter leads to a mixture of hexoses (C6 sugars) and pentoses (C5 sugars), and finding species that are able to uptake both simultaneously has proved a daunting task (see further). When traditional sources like sugary biomass (cane sugar) or corn starch are used as substrates, the fermentation is more easily carried out with wild-type organisms as only C6 sugars are involved.

For a biofuel to be competitive with fossil fuels, economics are the ruling factor that determines their viability. It has been estimated that to be considered as a route to a fossil fuel substitute, a microbial fermentation process needs to produce biofuel at a concentration of at least 100 g/L, with productivity greater

■ Table 14.1

Overview of most common biofuels produced using prokaryotes including the source and production path for their biological production

Biofuel type	Typical source	Typical production path	Role for prokaryotes
Biodiesel (fatty acid methyl ester)	Vegetable oils from rape seed, palm oil, microalgae	Transesterification of fats	Cyanobacterial production of lipids
Butanol (C ₄ H ₁₀ O)	Glucose, corn, waste biomass	Fermentation of organics	Fermentation
Ethanol (C ₂ H ₆ O)	Corn starch, molasses (typically sugarcane)	Hydrolysis and subsequent fermentation	Fermentation
Biohydrogen (H ₂)	Waste biomass, sludge	Thermophilic or mesophilic fermentation	Fermentation, photosynthesis
Biogas (CH ₄)	Sludge, waste biomass such as corn stover	Anaerobic digestion	Methanogenesis and hydrolysis + fermentation

than 2 g/L-h and a yield of 95% of the theoretical value (Sheridan 2009). Under this stringent set of constraints, not many species can be considered as options, and even the few that are considered viable often require genetic engineering to some extent to boost their productivities. The most significant species of prokaryotes to the biofuel industry are listed herein and their metabolic features explained in some details.

Zymomonas mobilis: Fermentation of Sugars to Ethanol

This Gram-negative bacterium is known for its remarkable ability to produce ethanol as homofermentation product to concentrations up to 120 g/L, with a productivity up to 200 g/L-h, that is 2.5 times that of the most commonly used organism for ethanol production, that is, the yeast *Saccharomyces cerevisiae* (Lee et al. 1980). *Z. mobilis* thus possesses the required characteristics for large scale production of bioethanol as a biofuel. It displays a high ethanol yield of 97% due to the low biomass growth, consequence of its low-ATP-yielding metabolism, which relies on the Entner-Doudoroff pathway for glycolysis (Weber et al. 2010). The main limitation of *Z. mobilis* is that it is substrate selective, fermenting only glucose, fructose, and sucrose. Its inability to take up pentose sugars like xylose and arabinose makes the bacterium inadequate for the fermentation of lignocellulosic hydrolysates, which contain roughly 30% of C5 sugars. The solution to this drawback came from insertion of genes necessary to ferment such sugars (Zhang et al. 1995), leading to a mutant that is able to process both hexoses and pentoses, however, preferentially taking up glucose and resorting to pentose sugars only when hexoses are depleted. The continuous improvements of genetically modified *Z. mobilis* have opened the way to industrial scale production. The company DuPont Danisco Cellulosic Ethanol (DDCE) has recently established a demonstration plant of cellulosic ethanol based on a modified *Z. mobilis* able to attain simultaneous xylose and glucose uptake while generating ethanol to a concentration of 100 g/L (Weber et al. 2010).

Modified *Escherichia coli*: Fermentation of Sugars to Ethanol

E. coli is certainly the most studied and most easily genetically engineered bacterium. The knowledge of its genome and metabolic regulation mechanisms makes it the ideal bacterium to generate mutants with desired characteristics. Its natural ability to ferment both hexoses and pentoses makes it ideal to process lignocellulosic hydrolysates. However, the wild type does not possess the genes to generate ethanol. The expression of pyruvate decarboxylase and alcohol dehydrogenase genes from *Z. mobilis* made it possible to exploit *E. coli* for bioethanol production (Ingram et al. 1987). Despite the promising outlook for bioethanol production, modified *E. coli* suffers from a number of limitations. Firstly, simultaneous fermentation of hexoses and pentoses does not occur in reality due to the downregulation of C5 sugar transport in the presence of glucose. Secondly, *E. coli* suffers from limited ethanol tolerance, with the fermentation coming to a stop at 35 g/L ethanol (Yomano et al. 1998). *E. coli* has been reengineered to produce a variety of other potential biofuels, including isopropanol (Hanai et al. 2007), n-butanol (Atsumi et al. 2008), and n-propanol (Shen and Liao 2008). However, despite the metabolic versatility of the organism, significant improvements are required to meet viability requirements for biofuel production with *E. coli*.

Clostridium phytofermentans and *Clostridium acetobutylicum*: Hydrolysis of Polysaccharides and Fermentation of Formed Monosaccharides to Ethanol

Most bacteria in the genus *Clostridia* are able to secrete a variety of carbohydrate-degrading enzymes (Lee et al. 1985), which enable them to directly saccharify a variety of polysaccharides (cellulose, starch, xylan, pectin, etc.) and oligosaccharides (cellobiose, lactose, maltose, etc.). This is a clear advantage over *Zymomonas* and modified *E. coli* for the production of biofuels from lignocellulosic biomass, as the latter bacteria are

not able to break down polysaccharides, thus requiring a prior step of enzymatic hydrolysis, typically carried out with a mixture of cellulases, hemicellulases, and glucosidases to hydrolyse cellulose and hemicellulose into monomeric sugars. These enzymes are often obtained via production by specific organisms, typically fungi (e.g., *Trichoderma*), either in a separate vessel, or concurrently to fermentation. *Clostridia* also exhibit a wide versatility in terms of monosaccharide fermentations, by effectively taking up both hexoses and pentoses simultaneously. Thus, in terms of their substrate hydrolysis and uptake capabilities, they are the ideal genus for biofuel production from lignocellulosics. *C. phytofermentans* produces primarily ethanol, acetate, and hydrogen with smaller amounts of lactate and formate (Warnick et al. 2002). *C. acetobutylicum* instead naturally produces a mixture of acetone, butanol, and ethanol in a typical ratio of 3:6:1 (Jones and Woods 1986). This is particularly interesting due to the fact that butanol is currently perceived as a possible fossil fuel replacement, as it fits into the present vehicle and fuel delivery infrastructure (Sheehan 2009). Both wild-type and modified strains have been tested, reaching maximum product concentrations of 8.2 g/L acetone, 2.2 g/L ethanol, and 17.6 g/L butanol, which are promising but still need significant improvement to compete with other processes.

Despite the astonishing metabolic capabilities, *Clostridia* are still facing several limitations. Their obligate anaerobic nature adds significant equipment costs to a potential industrial process; their low growth rate prevents rapid process start-up and would account for long process downtimes if the biomass is accidentally lost; their easy degeneration and sensitivity to bacteriophages reduces process stability and robustness.

***Corynebacterium glutamicum*: Fermentation of Sugars from Woody Biomass**

This bacterium has been exploited for industrial production of amino acids (Hermann 2003). It has gained some interest in the biofuel field as it possesses an advantage over all the microorganisms described above, that is, it is remarkably resistant to furans and phenols, which are by-products of the acid pretreatment typically used to break up the rigid structure of lignocellulose. These compounds are responsible for the inhibition of microbial activity in *Z. mobilis* and other bacteria tested for bioethanol production. As mentioned, these compounds are generated from acid pretreatment of woody biomass (Jeon et al. 2010), whereas herbaceous biomass does not entail as high a production. They are still in part responsible for the slow introduction of lignocellulosic bioethanol from woody sources. This explains the interest in *C. glutamicum* for bioethanol production. Unfortunately, the bacterium can only utilize hexose sugars and does not possess genes for ethanol fermentation, normally fermenting glucose to lactate. Once again, genetic engineering has been used to overcome the limitations. The genes that express pyruvate decarboxylase and alcohol dehydrogenase in *Z. mobilis* have been introduced and the endogenous lactate dehydrogenase gene deleted, resulting in a modified

strain able to convert glucose to ethanol at 53% efficiency (Inui et al. 2004). The genes for pentose uptake and metabolism were instead introduced from *E. coli*, resulting in a mutant that was able to utilize both hexoses and pentoses simultaneously (Sasaki et al. 2009).

Thermophilic Pure Cultures: Simultaneous Enzymatic Hydrolysis and Fermentation

With the objective of improving the conversion of lignocellulosic biomass to ethanol, pure cultures of thermophilic bacteria have been investigated in order to develop simultaneous saccharification and fermentation processes. In fact, the optimal temperature of lignocellulose enzymatic hydrolysis (>50 °C) is different from the optimal temperature for microbial fermentation (37 °C for *E. coli* but lower for other bacteria and yeasts). This difference in temperature optima has triggered the search for bacteria that exhibit maximum fermentation rates at higher temperatures. In that way, hydrolysis and fermentation could be carried out in the same vessel with reduced capital cost but also with improved process performance, as feedback inhibition of cellulases would be curbed by the continuous removal of sugars by the bacteria. Several species have been investigated with so far modest results. In particular, a modified *Thermoanaerobacterium saccharolyticum* (Shaw et al. 2008) and *Geobacillus thermoglucosidasius* (Fong et al. 2006) have given promising results. Of particular interest is the use of thermophilic species that are able to secrete cellulase enzymes, such as *Clostridium thermocellum*. In that case, further economic benefit would derive from the in situ production of hydrolytic enzymes by the bacterium itself.

Purple Non-Sulfur Bacteria: Photo-Fermentative Hydrogen Production

While all the strains described above ferment sugary and cellulosic biomass to bioalcohols, purple non-sulfur bacteria such as *Rhodobacter sphaeroides* specialize in photo-fermentative production of hydrogen gas. Unlike some eukaryotic green algae and cyanobacteria which are capable of direct or indirect biophotolysis (Levin et al. 2004), *R. sphaeroides* requires light as a source of energy and organic acids as exogenous source of carbon. During illumination, the organic acids are converted to CO₂ and H₂. *R. sphaeroides* was reported to generate photo-fermentative hydrogen at rates up to 100 mL H₂/L-h (Tsygankov et al. 1998) when in suspended culture and up to 4 L H₂/L-h when immobilized on a support (Tsygankov et al. 1994). In terms of energy output per unit volume of bioreactor, these values are still at least two orders of magnitude lower than the output achieved with ethanol production.

As organic acids are often obtained from dark fermentation of sugars by a number of genera (including *Enterobacter*, *Bacillus*, and *Clostridium*) with H₂ as a by-product, different cultures are often combined to maximize hydrogen yields (Rosenbaum et al. 2005) from sugars.

Mixed Culture Bioproduction

Mixed culture bioproduction technologies are competitive to traditional pure culture production processes for the production of energy carriers and chemicals. Comparing with pure culture bioproductions, advantages of mixed culture bioproduction processes include the following: the capacity to use mixed substrates, the absence of the requirements for sterilization, the higher adaptive capacity due to microbial diversity, and the possibility to continuously run the process (Kleerebezem and van Loosdrecht 2007). The application of mixed cultures is distinctive of processes aiming at the treatment of waste streams. Industrial and domestic wastewaters, as well as agricultural run-offs, are ideal feedstocks for bioprocessing because of their high content of degradable organic material. The integration of environmental biotechnologies with industrial biotechnology in recent years have seen the grade of these streams being changed from waste to raw materials for the production of chemicals or energy carriers such as methane and hydrogen.

This section will provide a short description of two types of processes that rely on bioconversion based on prokaryotic mixed cultures: anaerobic digestion for the production of methane (biomethanation) and mixed culture fermentation for the production of biohydrogen. Hydrogen production by photo-fermentation is also included in this section since, even if it requires a very specialized microbial consortium, it is performed under mixed non-sterile conditions.

Biomethanation

Anaerobic degradation of organic materials is a biological conversion process that yields the production of biogas (a mixture of methane and carbon dioxide) in the absence of an oxygen source. Anaerobic digestion of organic wastes provides important environmental benefits such as waste treatment and the production of methane as alternative to fossil fuels (Angelidaki et al. 2011). Anaerobic degradation proceeds mainly through a multistep process involving hydrolysis, fermentation (acidogenesis), anaerobic oxidation (syntrophic acetogenesis and methanogenesis from hydrogen), and acetoclastic methanogenesis (Batstone and Jensen 2011). The microorganisms involved in each step are well characterized and belong to at least three physiologically different microbial groups (Angelidaki et al. 2011; Hattori 2008): primary fermenting bacteria (hydrolytic-acidogenic bacteria), secondary fermenting bacteria (syntrophic-acetogenic bacteria), and methanogenic archaea.

Hydrolysis is an enzymatically mediated multistep process by which primary fermenting bacteria break down complex polymeric substances such as polysaccharides, carbohydrates, lipids, proteins, and nucleic acids, into monomers such as amino acids, long-chain fatty acids, glycerol, purines, etc. The enzymes required to carry out the process can be either attached to the microbial cell (Tong and McCarty 1991; Tong and McCarty 1991) or released into the bulk liquid by primary

fermenting bacteria (Jain et al. 1992). The second step of anaerobic degradation is performed by the same group of microorganisms, and involves fermentation (acidogenesis), which refers to the anaerobic conversion of organic matter in the absence of an inorganic external electron acceptor. Although a large range of substrates can be fermented, the two key groups of organics that undergo this conversion pathway are sugars and amino acids. The ways that these two components are fermented is completely different. However, the capability to utilize these substrates is widespread, with many microorganisms capable of degrading both these substrates, such as *Clostridia* and other low GC Gram-positive bacteria (Ramsay and Pullammanappallil 2001).

Fermentation from sugars is widely applied in the production of food products, pharmaceuticals, industrial chemicals, and renewable biofuels (mainly ethanol and butanol) (Batstone and Jensen 2011). Sugars ferment via the Embden-Meyerhof-Parnas (EMP) pathway to pyruvate and subsequently to C3 products (lactate or propionate) or C2-C6 products (acetate/butyrate/caproate) via acetyl-CoA (Madigan et al. 2000). Typical products of fermentation include acetate, butyrate, and ethanol, with excess carbon and electrons being released as carbon dioxide and hydrogen, respectively. The product range is generally controlled by parameters such as pH, hydrogen partial pressure, and temperature (Ren et al. 1997). Product regulation in mixed culture fermentation is advantageous as it offers the possibility of producing fuels and chemicals from raw feedstocks such as crop residues (Batstone and Jensen 2011). Fermentation of amino acids proceeds by direct oxidation coupled with fermentation in a process referred to as “Stickland reaction” (Winter et al. 1987), by which one amino acid acts as electron acceptor and is reduced to NH_3 and a carboxylic acid with a chain length equal to the original amino acid, while the other acts as the electron donor and is oxidized to NH_3 , CO_2 , and a carboxylic acid with a chain length one carbon atom shorter than the original donor.

Acetogenesis is a process by which acetate is produced from higher organic acids and alcohols produced during the previous steps of fermentation by hydrogen-producing acetogens. During the anaerobic oxidation of organic acids and alcohols, hydrogen ions or bicarbonate ions are used to produce hydrogen gas or formate, respectively, in general with unfavorable energetics, which requires that in order to derive energy for growth from these conversions, the concentrations of the products (hydrogen or formate) must be kept at very low levels. Hence, acetogenesis must be obligatorily linked to a hydrogen-utilizing reaction for products removal (McInerney et al. 2009). Even if hydrogenotrophic methanogenesis prevails in anaerobic environments, other processes can also occur, such as nitrate reduction, sulfate reduction, iron reduction, and homoacetogenesis (i.e., the synthesis of acetate from CO_2 and hydrogen). Interspecies electron transfer (IET) refers to the process by which electrons are shuttled from the oxidizing organism (normally a *bacterium*) to the hydrogen-utilizer organism (normally a *archaea*) via carriers such as hydrogen or formate (Batstone et al. 2006).

The acetate generated by acetogenesis can be used to generate methane and CO₂ directly by aceticlastic methanogenesis (see below), or it can be degraded syntrophically by acetate oxidizers and hydrogenotrophic methanogens (Hattori 2008). The reaction yields very low energy that, however, increases at higher temperatures (Schink and Stams 2006).

A number of thermophilic and mesophilic acetate oxidizers have been isolated, including *Thermacetogeneum phaeum*, *Thermotoga lettingae*, *Clostridium ultunense*, *Syntrophaceticus schinkii*, etc. (Hattori 2008; Schnurer et al. 1996; Westerholm et al. 2010).

The major methanogenic step during anaerobic organic degradation is represented by aceticlastic methanogenesis. During this process, acetate is cleaved to methane and carbon dioxide by a limited number of methanogens within the archaea domain. While members of the genus *Methanosaeta* within Methanosaetaceae can only cleave acetate, members of the genus *Methanosarcina* within the Methanosarcinaceae can also produce CH₄ from hydrogen, CO₂, and methylated compounds with one C atom (Batstone and Jensen 2011; Ferry 1993). *Methanosarcina* generally dominates in high ammonia conditions with high levels of acetate (>10⁻³ M) (Karakashev et al. 2005). Interestingly, recent observations have also suggested that *Methanosarcina* may be able to oxidize acetate with concomitant production of hydrogen and CO₂ that is then reduced to methane by a syntrophic methanogenic partner (Karakashev et al. 2006).

Biological Hydrogen Production

With an energy content of 122 kJ/g, hydrogen is regarded as a very promising fuel that can be used in combustion engines without generating emissions of CO_x, SO_x, and NO_x, and also as energy carrier that can be then used in fuel cells for direct electricity generation (Argun and Kargi 2011).

Hydrogen production from renewable resources such as biomasses and wastewater by means of biological processes offers several environmental benefits compared to high energy-intensive processes such as steam reforming of natural gas and water electrolysis, although biohydrogen production is subject to lower product yields and production rates, and as such, it requires high reactor volumes to achieve production rates comparable to traditional processes (Kapdan and Kargi 2006). Two biological processes are mainly used for biohydrogen production-based mixed fermentation, which differ substantially in the key microbial players as well as process operation: dark- and photo-fermentation. While biophotolysis of water is also biologically mediated, the process is hampered by low H₂ productivity rates and is very prone to oxygen inhibition, which makes it not competitive with fermentative processes, and, as such, it will not be discussed in this chapter.

Dark fermentation refers to the fermentative conversion of organic material to hydrogen gas. It shares many of the features common to methanogenic anaerobic degradation, except that the main product of the conversion is hydrogen and not

methane. Contrarily to photo-fermentation, which will be discussed below, dark fermentation does not require light to increase the free energy released by the reaction. Dark fermentation and anaerobic digestion both rely on mixed microbial communities with similar elements with, however, a very important difference. Biological hydrogen production requires inhibition of hydrogen-consuming microorganisms, such as hydrogenotrophic methanogenic archaea and homoacetogenic bacteria, which reduce the hydrogen yields by producing methane and acetate, respectively. Inhibition is normally achieved by treatment of the inoculum, resulting in the selective enrichment of fermenting bacteria such as spore forming *Clostridium* species, *Streptococcus* sp., *Sporolactobacillus* sp., facultative *Enterobacter* sp., *Bacillus* sp., as well as some thermophilic bacteria (Kapdan and Kargi 2006; Levin 2004; Xu et al. 2010). Heat shock, acid or alkaline treatment, sonication, and 2-bromoethansulfonic acid treatment are among the most used pretreatments of the inoculum (Argun and Kargi 2011). The main substrates for hydrogen formation are monosaccharides generated by hydrolysis of polysaccharides such as cellulose. Conversion of glucose through dark fermentation produces theoretically a maximum of 4 moles of H₂, 2 moles of acetic acid, and 2 moles of CO₂, with hydrogenase acting as the main enzyme in the catalysis of hydrogen formation (Trohalaki and Pachter 2010). However, H₂ yields range in practice from <1 to about 2.5 moles H₂ per mole hexose due to the production of VFAs other than acetate and also because H₂ consumers may still develop during the process operations, especially in mixed non-sterile cultures (Angenent et al. 2004). This represents a small portion of the total equivalent of H₂ present in waste streams (equal to 12 moles H₂ per mole hexose), which makes dark fermentation less energy efficient than methanogenic anaerobic digestion.

Biohydrogen production by photo-fermentation is achieved by conversion of VFAs to H₂ and CO₂ by photosynthetic purple non-sulfur bacteria such as *Rhodobacter capsulatus*, *Rhodobacter sphaeroides*-RV, *Rhodobacter sulfidophilus*, and *Rhodobacter palustris* (Basak and Das 2007). While hydrogenase and nitrogenase enzymes are both detected in bacteria performing photo-fermentation, nitrogenase appears as the main contributor to hydrogen formation in these systems (Koku et al. 2002). The conversion of VFAs into hydrogen is thermodynamically unfavorable, and, as such, it requires energy input, which is provided by light. The process requires finely controlled conditions and specific microorganisms to operate efficiently. Parameters such as temperature, pH, light intensity, and carbon source have to be finely controlled to maximize the hydrogen production yields and light efficiency (Argun et al. 2008a, b).

Light-Driven Biodiesel

Biodiesel is perceived as one of the key renewable fuels for the future alongside ethanol and butanol. Its production technology is rather mature, and the product can be used in existing diesel engines with minor modifications and could be distributed

using the current infrastructure. The production technology typically involves transesterification of oils (lipids) extracted from vegetal, animal, or algal sources. Lipids are normally triglycerides which, upon transesterification with methanol in the presence of acid or base as catalyst, form fatty acid methyl esters (FAMES) and glycerol. The separated and purified FAMES are good to use as biodiesel, while glycerol is a waste product of insignificant value.

As plant-based oil crops are frowned upon as they compete with food crops and/or destroy important ecosystems such as tropical rainforests, focus has shifted to microalgal oils as main feedstock for biodiesel production. While most of the research carried out thus far has used eukaryotic microalgal species for lipid accumulation, recently, some work has proven that prokaryotic species such as cyanobacteria do accumulate lipids as well, and thus, they are potentially a promising feedstock as well. In particular, Wahlen et al. (2011) reported that *Synechocystis* sp. PCC 6803 and *Synechococcus elongatus* were able to accumulate lipids up to 18.4% and 17.7% of their dry biomass weight, respectively, when grown on BG-11 medium with 1.5 g/L NaNO₃. A study by Karatay and Donmez (2011) showed that the lipid fraction could increase significantly if the sodium nitrate concentration in the medium is reduced to 0.25 g/L, with maximal lipid contents of 42.8% for *Synechococcus* sp., 45.0% for *Cyanobacterium aponium*, and 38.2% for *Phormidium* sp. These values bring cyanobacteria to the levels of eukaryotic microalgae for lipid storage.

Novel Concepts

The production of biofuels via conversion of lignocellulosics to bioalcohols or oils to biodiesel is an intrinsically inefficient processes, in that atmospheric carbon dioxide is first reduced to complex organics (with significant biological energy investment) which subsequently needs to be hydrolyzed/extracted and biologically/chemically converted into usable biofuels. The intermediate complex organics (polysaccharides and oils) are difficult to break down and separate, leading to significant limitations in terms of productivity and energy efficiency. This problem has led to the development of new concepts for the production of bioalcohols through different pathways, primarily syngas fermentations and direct conversion of CO₂ to alcohols using cyanobacteria.

Syngas Fermentations to Bioalcohols

Lignocellulosic biomass can be converted to syngas alternatively to being hydrolyzed. Syngas is a mixture of carbon monoxide (CO) and hydrogen gas (H₂) which is obtained upon heating biomass in the presence of limited levels of oxygen. This way, not only polysaccharides but the complete biomass can be converted. While it requires energy for heating, this process has the advantage that all of the carbon is turned into a single product (CO) rather than a complex mix of mono- and

oligosaccharides. Several bacterial species are known to take up carbon monoxide to oxidize part of it to CO₂ while reducing the rest to acetyl-CoA and from there to an array of possible fermentation products, including ethanol and butanol. Examples of such bacteria are *Clostridium carboxidivorans* and *Clostridium ljungdahlii* (Kopke et al. 2010), both of which have been sequenced and are current subject of genetic engineering to enhance their performance. A severe limitation of CO fermentation is the limited water solubility of CO in water. This issue has been addressed by the use of membrane bioreactors to increase the availability of CO to the bacteria (Wilkins and Atiyeh 2011).

Direct Photosynthetic Conversion of CO₂ to Bioalcohols

The organic matter used for biofuel production is typically produced from carbon dioxide in plants and algae via photosynthesis. It is subsequently harvested, broken down to simpler molecules, and fermented. A more efficient alternative to this indirect pathway would be to devise a pathway for the direct conversion of CO₂ to biofuels, whereby phototrophic organisms utilize CO₂ and water to produce alcohols instead of cell biomass and storage polymers. Such organisms would need to possess the genes to encode both photosynthesis and alcoholic fermentation. The quest for such organism has been ongoing for a number of years, with the focus being on genetically modified cyanobacterial species. Cyanobacteria are prokaryotic phototrophs that are well characterized and easily transformed. Deng and Coleman (1999) introduced pyruvate decarboxylase and alcohol dehydrogenase into *Synechococcus* sp. PCC 7942 to obtain a mutant that was able to accumulate ethanol in solution at the rate of 0.34 mg/L-h. Fu (2009) succeeded in increasing the ethanol production rate to 4.1 mg/L-h with *Synechocystis* sp. PCC 6803. Expression of an isobutanol fermentation pathway in *Synechococcus elongatus* PCC 7942 enabled the production of butanol from CO₂ at the rate of 3 mg/L-h (Atsumi et al. 2009). The same bacterium modified with pyruvate decarboxylase but not alcohol dehydrogenase generated isobutyraldehyde at the rate of 6 mg/L-h.

While these results are promising, the productivity of these modified organisms are still far below the levels of productivity for saccharide fermentation bacteria (>100 g/L-h). However, when compared in terms of productivity per hectare, these direct CO₂-to-alcohol conversion processes are competitive with biodiesel from algal lipids and even superior to land-crop-based ethanol (Sheehan 2009).

Perspectives

The metabolic versatility of prokaryotes has enabled the development of a number of processes for the conversion of organic matter (or CO₂ directly, for third-generation biofuels) to biofuels at high energy density, which are suitable for

transportation vehicles. While several eukaryotic processes have been proposed and developed, especially through the use of *Saccharomyces cerevisiae* for ethanol fermentation of sugars and eukaryotic microalgae (such as *Chlorella vulgaris*) for bio-diesel generation, prokaryotes are typically faster growing, more sturdy, and more easily modified to address the issues of substrate complexity, by-product inhibition, and purity of the desired product.

Unfortunately, none of the prokaryotic processes to biofuels is ready for large scale implementation due to limitations such as limited productivity per hectare for bioethanol (Rittmann 2008). Biodiesel from phototrophic bacteria and microalgae suffers from limited densities of their cell suspensions, which entails high biomass separation and lipids extraction cost (Chisti 2008). Biohydrogen is still not viable due to the minute production rates achieved thus far. Further engineering of the microorganisms in combination with improved process development can in some cases circumvent these constraints. Methane produced as biogas by anaerobic digestion of human, animal, and agricultural waste is today the only established technology for mass production of transportation fuels and may pave the way for the next-generation biofuels (Tilche and Galatola 2008; Rittmann 2008).

Acknowledgements

SF, BV, and KR are supported by Australian Research Council grants, LP100200223, and DP0985000, respectively. BV is supported by an Early Career Researcher grant (The University of Queensland). KR acknowledges support by the MRP "biotechnology for a sustainable economy" (Bijzonder Onderzoeksfonds, Ghent University), ARC DP0879245, and CSIRO Energy Transformed Flagship Cluster.

References

- Angelidaki I, Karakashev D, Batstone DJ, Plugge CM, Stams AJM (2011) Biomethanation and its potential. *Methods Enzymol: Methods Methane Metabol*, Pt A 494:327–351
- Angenent LT, Karim K, Al-Dahhan MH, Domiguez-Espinosa R (2004) Production of bioenergy and biochemicals from industrial and agricultural wastewater. *Trends Biotechnol* 22:477–485
- Argun H, Kargi F (2011) Bio-hydrogen production by different operational modes of dark and photo-fermentation: an overview. *Int J Hydrog Energy* 36:7443–7459
- Argun H, Kargi F, Kapdan IK (2008a) Light fermentation of dark fermentation effluent for bio-hydrogen production by different *Rhodobacter* species at different initial volatile fatty acid (VFA) concentrations. *Int J Hydrog Energy* 33:7405–7412
- Argun H, Kargi F, Kapdan FK, Oztekin R (2008b) Biohydrogen production by dark fermentation of wheat powder solution: effects of c/n and c/p ratio on hydrogen yield and formation rate. *Int J Hydrog Energy* 33:1813–1819
- Atsumi S, Cann AF, Connor MR, Shen CR, Smith KM, Brynildsen MP, Chou KJY, Hanai T, Liao JC (2008) Metabolic engineering of *Escherichia coli* for 1-butanol production. *Metab Eng* 10:305–311
- Atsumi S, Higashide W, Liao JC (2009) Direct photosynthetic recycling of carbon dioxide to isobutyraldehyde. *Nat Biotechnol* 27:1177–1180
- Axsen J, Kurani KS, Burke A (2010) Are batteries ready for plug-in hybrid buyers? *Transp Policy* 17:173–182
- Basak N, Das D (2007) The prospect of purple non-sulfur (PNS) photosynthetic bacteria for hydrogen production: the present state of the art. *World J Microbiol Biotechnol* 23:31–42
- Batstone D, Jensen P (2011) Anaerobic processes. In: Wilderer P (ed) *Treatise on water science*. Elsevier, Oxford
- Batstone DJ, Picioreanu C, van Loosdrecht MCM (2006) Multidimensional modelling to investigate interspecies hydrogen transfer in anaerobic biofilms. *Water Res* 40:3099–3108
- Campbell JE, Lobell DB, Field CB (2009) Greater transportation energy and GHG offsets from bioelectricity than ethanol. *Science* 324:1055–1057
- Chisti Y (2008) Response to reijnders: Do biofuels from microalgae beat biofuels from terrestrial plants? *Trends Biotechnol* 26:351–352
- Clarens AF, Resurreccion EP, White MA, Colosi LM (2010) Environmental life cycle comparison of algae to other bioenergy feedstocks. *Environ Sci Technol* 44:1813–1819
- Deng MD, Coleman JR (1999) Ethanol synthesis by genetic engineering in cyanobacteria. *Appl Environ Microbiol* 65:523–528
- Evans K (2009) The future of electric vehicles: setting the record straight on lithium availability. *J Ener Secur*:7. http://www.ensec.org/index.php?option=com_content&view=article&id=213:the-future-of-electric-vehicles-setting-the-record-straight-on-lithium-availability&catid=98:issuecontent0809&Itemid=349
- Ferry JG (1993) *Methanogenesis: ecology, physiology, biochemistry and genetics*. Chapman and Hall, New York
- Fong JC, Svenson CJ, Nakasugi K, Leong CT, Bowman JP, Chen B, Glenn DR, Neilan BA, Rogers PL (2006) Isolation and characterization of two novel ethanol-tolerant facultative-anaerobic thermophilic bacteria strains from waste compost. *Extremophiles: Life Under Extrem Cond* 10:363–372
- Fu PC (2009) Genome-scale modeling of *Synechocystis* sp. Pcc 6803 and prediction of pathway insertion. *J Chem Tech Biotechnol* 84(4):473–483
- Hanai T, Atsumi S, Liao JC (2007) Engineered synthetic pathway for isopropanol production in *Escherichia coli*. *Appl Environ Microbiol* 73:7814–7818
- Hattori S (2008) Syntrophic acetate-oxidizing microbes in methanogenic environments. *Microbes Environ* 23:118–127
- Hermann T (2003) Industrial production of amino acids by coryneform bacteria. *J Biotechnol* 104:155–172
- Ingram LO, Conway T, Clark DP, Sewell GW, Preston JF (1987) Genetic-engineering of ethanol-production in *Escherichia coli*. *Appl Environ Microbiol* 53:2420–2425
- Inui M, Kawaguchi H, Murakami S, Vertes AA, Yukawa H (2004) Metabolic engineering of *Corynebacterium glutamicum* for fuel ethanol production under oxygen-deprivation conditions. *J Mol Microbiol Biotechnol* 8:243–254
- Jain S, Lala AK, Bhatia SK, Kudchadker AP (1992) Modeling of hydrolysis controlled anaerobic-digestion. *J Chem Technol Biotechnol* 53:337–344
- Jeon YJ, Xun Z, Rogers PL (2010) Comparative evaluations of cellulosic raw materials for second generation bioethanol production. *Lett Appl Microbiol* 51:518–524
- Jones DT, Woods DR (1986) Acetone-butanol fermentation revisited. *Microbiol Rev* 50:484–524
- Kapdan IK, Kargi F (2006) Bio-hydrogen production from waste materials. *Enzyme Microb Technol* 38:569–582
- Karakashev D, Batstone DJ, Angelidaki I (2005) Influence of environmental conditions on methanogenic compositions in anaerobic biogas reactors. *Appl Environ Microbiol* 71:331–338
- Karakashev D, Batstone DJ, Trably E, Angelidaki I (2006) Acetate oxidation is the dominant methanogenic pathway from acetate in the absence of methanosetaeaceae. *Appl Environ Microbiol* 72:5138–5141
- Karatay SE, Donmez G (2011) Microbial oil production from thermophile cyanobacteria for biodiesel production. *Applied Energy* 88:3632–3635
- Kleerebezem R, van Loosdrecht MCM (2007) Mixed culture biotechnology for bioenergy production. *Curr Opin Biotechnol* 18:207–212
- Koku H, Eroglu I, Gunduz U, Yucel M, Turker L (2002) Aspects of the metabolism of hydrogen production by *Rhodobacter sphaeroides*. *Int J Hydrog Energy* 27:1315–1329

- Kopke M, Held C, Hujer S, Liesegang H, Wiezer A, Wollherr A, Ehrenreich A, Liebl W, Gottschalk G, Durre P (2010) *Clostridium ljungdahlii* represents a microbial production platform based on syngas. *Proc Natl Acad Sci USA* 107:13087–13092
- Kumar P, Barrett DM, Delwiche MJ, Stroeve P (2009) Methods for pretreatment of lignocellulosic biomass for efficient hydrolysis and biofuel production. *Ind Eng Chem Res* 48:3713–3729
- Lee KJ, Lefebvre M, Tribe DE, Rogers PL (1980) High productivity ethanol fermentations with *Zymomonas-mobilis* using continuous cell recycle. *Biotechnol Lett* 2:487–492
- Lee SF, Forsberg CW, Gibbins LN (1985) Xylanolytic activity of *Clostridium acetobutylicum*. *Appl Environ Microbiol* 50:1068–1076
- Levin DB (2004) Re: biohydrogen production: prospects and limitations to practical application – erratum. *Int J Hydrog Energy* 29:1425–1426
- Levin DB, Pitt L, Love M (2004) Biohydrogen production: prospects and limitations to practical application. *Int J Hydrog Energy* 29:173–185
- Madigan M, Martinko J, Parker J (ed) (2000) *Brock biology of microorganisms*. Prentice Hall, Upper Saddle River, New Jersey
- McInerney MJ, Sieber JR, Gunsalus RP (2009) Syntrophy in anaerobic global carbon cycles. *Curr Opin Biotechnol* 20:623–632
- Ramsay IR, Pullammanappallil PC (2001) Protein degradation during anaerobic wastewater treatment: derivation of stoichiometry. *Biodegradation* 12:247–257
- Ren NQ, Wang BZ, Huang JC (1997) Ethanol-type fermentation from carbohydrate in high rate acidogenic reactor. *Biotechnol Bioeng* 54:428–433
- Rittmann BE (2008) Opportunities for renewable bioenergy using microorganisms. *Biotechnol Bioeng* 100:203–212
- Rosenbaum M, Schroder U, Scholz F (2005) In situ electrooxidation of photobiological hydrogen in a photobioelectrochemical fuel cell based on *Rhodobacter sphaeroides*. *Environ Sci Technol* 39:6328–6333
- Sasaki M, Jojima T, Kawaguchi H, Inui M, Yukawa H (2009) Engineering of pentose transport in *Corynebacterium glutamicum* to improve simultaneous utilization of mixed sugars. *Appl Microbiol Biotechnol* 85:105–115
- Schink B, Stams AJM (2006) Syntrophism among prokaryotes, vol 2, 3rd edn, *Prokaryotes: a handbook on the biology of bacteria.*, pp 309–335
- Schnurer A, Schink B, Svensson BH (1996) *Clostridium ultunense* sp nov, a mesophilic bacterium oxidizing acetate in syntrophic association with a hydrogenotrophic methanogenic bacterium. *Int J Syst Bacteriol* 46:1145–1152
- Shaw AJ, Podkaminer KK, Desai SG, Bardsley JS, Rogers SR, Thorne PG, Hogsett DA, Lynd LR (2008) Metabolic engineering of a thermophilic bacterium to produce ethanol at high yield. *Proc Natl Acad Sci USA* 105:13769–13774
- Sheehan J (2009) Engineering direct conversion of CO₂ to biofuel. *Nat Biotechnol* 27:1128–1129
- Shen CR, Liao JC (2008) Metabolic engineering of *Escherichia coli* for 1-butanol and 1-propanol production via the keto-acid pathways. *Metab Eng* 10:312–320
- Sheridan C (2009) Making green. *Nat Biotechnol* 27:1074–1076
- Tilche A, Galatola M (2008) The potential of bio-methane as bio-fuel/bio-energy for reducing greenhouse gas emissions: a qualitative assessment for Europe in a life cycle perspective. *Water Sci Technol* 57:1683–1692
- Tong X, McCarty PL (1991) Microbial hydrolysis of lignocellulosic materials. In: Isaacson R (ed) *Methane from community wastes*. Elsevier Applied Science, London, pp 61–100
- Trohalaki S, Pachter R (2010) The effects of the dimethylether bridging moiety in the h-cluster of the *Clostridium pasteurianum* hydrogenase on the mechanism of h(2) production: a quantum mechanics/molecular mechanics study. *Int J Hydrog Energy* 35:13179–13185
- Tsygankov AA, Hirata Y, Miyake M, Asada Y, Miyake J (1994) Photobioreactor with photosynthetic bacteria immobilized on porous-glass for hydrogen photoproduction. *J Ferment Bioeng* 77:575–578
- Tsygankov AA, Fedorov AS, Laurinavichene TV, Gogotov IN, Rao KK, Hall DO (1998) Actual and potential rates of hydrogen photoproduction by continuous culture of the purple non-sulphur bacterium *Rhodobacter capsulatus*. *Appl Microbiol Biotechnol* 49:102–107
- Wahlen BD, Willis RM, Seefeldt LC (2011) Biodiesel production by simultaneous extraction and conversion of total lipids from microalgae, cyanobacteria, and wild mixed-cultures. *Bioresour Technol* 102:2724–2730
- Warnick TA, Methe BA, Leschine SB (2002) *Clostridium phytofermentans* sp nov., a cellulolytic mesophile from forest soil. *Int J Syst Evol Microbiol* 52:1155–1160
- Weber C, Farwick A, Benisch F, Brat D, Dietz H, Subtil T, Boles E (2010) Trends and challenges in the microbial production of lignocellulosic bioalcohol fuels. *Appl Microbiol Biotechnol* 87:1303–1315
- Westerholm M, Roos S, Schnurer A (2010) *Syntrophaceticus schinkii* gen. Nov., sp nov., an anaerobic, syntrophic acetate-oxidizing bacterium isolated from a mesophilic anaerobic filter. *FEMS Microbiol Lett* 309:100–104
- Wilkins MR, Atiyeh HK (2011) Microbial production of ethanol from carbon monoxide. *Curr Opin Biotechnol* 22:326–330
- Winter J, Schindler F, Wildenauer FX (1987) Fermentation of alanine and glycine by pure and syntrophic cultures of clostridium-sporogenes. *FEMS Microbiol Ecol* 45:153–161
- Xu JF, Ren NQ, Wang AJ, Qiu J, Zhao QL, Feng YJ, Liu BF (2010) Cell growth and hydrogen production on the mixture of xylose and glucose using a novel strain of *Clostridium* sp. Hr-1 isolated from cow dung compost. *Int J Hydrog Energy* 35:13467–13474
- Yomano LP, York SW, Ingram LO (1998) Isolation and characterization of ethanol-tolerant mutants of *Escherichia coli* ko11 for fuel ethanol production. *J Ind Microbiol Biotechnol* 20:132–138
- Zhang M, Eddy C, Deanda K, Finkstein M, Picataggio S (1995) Metabolic engineering of a pentose metabolism pathway in *Ethanologenic Zymomonas-mobilis*. *Science* 267:240–243

15 The Metabolic Pathways of Biodegradation

Lawrence P. Wackett

Department of Biochemistry, Molecular Biology and Biophysics, BioTechnology Institute,
University of Minnesota, St. Paul, MN, USA

Introduction	383
History	383
Scope of Biodegradation in the Modern World	383
The University of Minnesota	
Biocatalysis/Biodegradation Database	384
Methodological Advances Relevant to Biodegradation	384
Enrichment Culture	384
Anaerobic Culturing Methods and Biodegradation	385
Analytical Chemistry	385
Whole Genome Sequencing and Analysis	385
The Prokaryotes of Biodegradation	386
Themes in Biodegradation Pathways	389
Occurrence of Similar Pathways in Divergent	
Prokaryotes	389
Common Themes in Catabolic Pathways	390

Abstract

Biodegradation is the study of metabolic breakdown of chemicals, both natural and anthropogenic. Globally, biodegradation is principally carried out by microorganisms. Microbes carry out diverse metabolic reactions and this gives them the ability to break down many synthetic chemicals that have been made for commercial purposes. The University of Minnesota Biocatalysis/Biodegradation Database [UM-BBD] (<http://umbbd.ethz.ch>) has captured information on diverse biodegradation reactions and shows metabolic pathways degrading natural and synthetic chemicals. A software tool is available on the database to predict the biodegradation of any organic chemical entered by the user.

Introduction

History

The decay (biodegradation) of organic matter has been a part of life throughout human history. When the organic matter was a person's food, clothing, or dwelling, biodegradation was no doubt very undesirable. In this context, humans have, through most of their history, sought to prevent or, more practically, slow down biodegradation. Animal hides were treated with tannins to

cross-link proteins and prevent their degradation. Food was dried, salted, or pickled to prevent microbial growth and, hence, spoilage.

Though solutions to biodegradation were found, the underlying causes of the phenomenon were less clear. But no doubt, correlations were made by direct observation of macroscopic microorganisms, typically fungi, on rotting material. People could see wood rot fungi on decaying wood or hyphal masses on bread. And, in fact, some of the foundations for the science of microbiology were established with macroscopic fungi. Micheli showed that fungi now known as *Mucor*, *Botrytis*, and *Aspergillus* could be cultivated on the surfaces of fresh-cut melon, quince, and pear (Bull and Slater 1982). Micheli serially transferred the fungi, thus initiating the practice of isolating, maintaining, and characterizing specific genera of microorganisms. He also observed that different fungal genera showed preferences for certain fruits used as the cultivating medium, thus establishing the idea of selective culture.

In fact, these observations became entwined with the controversy over spontaneous generation because macroscopic fungal growth derived from microscopic fungal spores. Many interpreted proliferation of microscopic life, biodegrading different organic material, as the spontaneous generation of life from nonlife. Louis Pasteur is generally credited with demonstrating most convincingly that the elimination of all bacterial and fungal contamination would prevent spoilage (Clarke 1985). It was recognized from the work of Pasteur, Tyndall, and others that bacteria are ubiquitous and difficult to remove from any given environment.

In a broad sense, virtually all prokaryotes participate in biodegradation. Prokaryotes decompose (biodegrade) organic molecules as part of their need to derive chemical energy to make ATP or to produce metabolic intermediates. In the early twentieth century, Beijerinck (1901) and Winogradsky (1890) contributed to the current idea that prokaryotes are important in the recycling of carbon, nitrogen, sulfur, and other elements on a global scale. For example, we now know that 10^{15} g of methane gas is produced annually by anaerobic Archaea known as "methanogens" and most of the biogenic methane is oxidized by aerobic methanotrophic bacteria (Lipscomb 1994). This constitutes one small part of the global carbon cycle. If one considers that over ten million organic compounds are known, many of which are theoretically biodegradable, the magnitude of these cycles is enormous.

Scope of Biodegradation in the Modern World

Although naturally occurring compounds biodegrade on a massive scale, the biodegradation of synthetic compounds attracts more interest. Over the last century, some synthetic, industrial chemicals have been shown to exert toxic or carcinogenic effects on humans. For example, factory workers in aniline dye (Bulbulyan et al. 1995) and vinyl chloride polymer industries (Langard et al. 2000) were developing certain cancers at relatively high rates, and the epidemiological studies were confirmed in animals. From these observations has emerged the awareness that, with increasing world population, more effort must be expended to maintain clean water, air, and soil.

Problems of human exposure to potentially harmful organic compounds can be handled in different ways. For example, certain chemicals may be banned, manufacturing processes can be made cleaner, or wastes can be treated at the source or in the open environment. In fact, all of those are occurring. And prokaryotes are increasingly being exploited for treating wastes, either in the manufacturing facility or for remediation of chemical spills or releases. Some high profile applications have been published (Harkness et al. 1993; Roberts et al. 1993; Strong et al. 2000; Wagner-Dobler et al. 2000), but in fact, most of these applications are quietly in use at manufacturing facilities all around the globe.

The University of Minnesota Biocatalysis/Biodegradation Database

To facilitate the use of microbial catalysis, either for developing cleaner manufacturing or treating wastes, we have developed the University of Minnesota Biocatalysis/Biodegradation Database [UM-BBD] (<http://umbbd.ahc.umn.edu>).

The UM-BBD provides information on microbial biocatalytic non-intermediary metabolism (i.e., reactions generally associated with biodegradation of synthetic industrial chemicals; Ellis et al. 2000). This metabolism is considered non-intermediary because it is restricted to only a few prokaryotes. It is these non-intermediary metabolic reactions that biotransform compounds and funnel them into the central metabolism of most prokaryotes. For example, only a limited number of prokaryotes can catabolize nitrobenzene, as shown, but many organisms can metabolize the open-chain carboxylic acid products of those initial catabolic, or biodegradative, reactions. Intermediary metabolism databases such as KEGG, the Kyoto Encyclopedia of Genes and Genomes, which includes the LIGAND database of enzymes and reactions (Goto et al. 2000), depict this process. For example, one of the metabolic pathways for nitrobenzene is shown on the UM-BBD to yield 2-aminomuconate semialdehyde and the metabolic fate of this latter compound is shown on KEGG (<http://www.genome.ad.jp>).

It is important to study the pathways of biodegradation to insure that more highly toxic compounds are not generated as

the result of microbial metabolism. This concern was raised by the recent observation that the widely used industrial solvent trichloroethylene undergoes reductive dechlorination, generating vinyl chloride as an intermediate (Vogel and McCarty 1985). See http://umbbd.ahc.umn.edu/tce2/tce2_map.html for more information about this pathway. Because it is a strong human carcinogen, vinyl chloride is a greater environmental problem than trichloroethylene (Maltoni and Cotti 1988). So it is not enough to know that a pollutant is disappearing from a given environment; regulatory agencies increasingly need to account for its complete environmental fate.

Methodological Advances Relevant to Biodegradation

Enrichment Culture

In the late 1800s, microbiologists largely focused on the bacteria that cause disease in humans. Isolating the disease-causing bacteria directly from an infected tissue was relatively easy because the infection was largely a monoculture. Thus, plating onto a rich medium might well yield a single organism that could be studied for its disease-causing properties.

This contrasted with the situation in a natural soil or water where thousands of different bacteria might well be present in a gram of material. In this case, culturing on a nonselective laboratory medium would yield a complex mixture, difficult to analyze for one particular metabolic trait. Thus, one needed to enrich the mixture to obtain one or a few different types of bacteria. This would simplify the system so that it could be studied productively.

As pioneered by the Dutch microbiologist Beijerinck (1901), the enrichment culture technique allowed selective cultivation of one or more bacterial strains obtained from complex environmental mixtures. Assume that one wanted to study the ability of microorganisms in a particular soil to metabolize a given compound. The compound would then be added as the sole carbon, nitrogen, or sulfur source to a liquid laboratory medium lacking one of those major elements but containing the others and trace nutrients. The medium would then be inoculated with soil or water, perhaps adding as many as 10^{11} bacteria. If only a few of the bacteria are able to metabolize the compound to meet their nutritional needs, they will reproduce, or be enriched, selectively. The numbers of these specific bacteria will increase markedly in comparison to what is present in the native soil or water where alternative carbon, nitrogen, or sulfur sources are present. With repeated transfer of the enriched microbial mixture into fresh growth medium, the numbers of the preferred bacterium will sometimes increase to the extent that it can be readily isolated.

The preferred bacterium is one that can metabolize the given compound, utilize the trace nutrients provided, grow at the temperature used in the laboratory, and reproduce quickly. In this context, one may not necessarily obtain the bacterium most prevalent in the original sampled environment. For this reason,

some people have criticized the practice of obtaining and characterizing prokaryotes in pure culture as unsuited to yielding insights into what occurs in nature. But think of the difficulties inherent in trying to learn the details of biodegradation in a complex milieu such as soil. The metabolism of a particular compound might be inferred if it is disappearing from soil, but one has to rule out abiotic reactions in soil, and soil can be difficult to sterilize. If the compound is available in a radiolabeled form, an accumulating intermediate may be obtained if it is stable in soil. This may or may not yield insights into metabolic pathways. But one would be hard-pressed to learn about the other metabolites, the enzymes, genes, and specific microorganisms involved. In short, without obtaining pure cultures, one could learn whether a compound is metabolized but little about the molecular details.

The use of prokaryote pure cultures, many of which have been obtained by enrichment culture, has been instrumental in the identification of the many novel enzymes catalyzing metabolic transformations that drive the carbon, nitrogen, and sulfur cycles of Earth. In turn, the corresponding genes have been identified; at first, these were identified singly and now wholesale as the result of genome sequencing efforts, which focused initially on prokaryotes because of their relatively small genome size. Without the development of enrichment culture, we would know far less about the Earth's biological cycles, the catalytic diversity of the planet, and the microbial phylogenetic diversity.

Anaerobic Culturing Methods and Biodegradation

Most of our early knowledge on biodegradation derived from studies on aerobic or facultative bacteria. This reflected the comparative ease of studying aerobic versus anaerobic bacteria. Anaerobic conditions were fairly easy to maintain with mixed cultures because facultative organisms would consume oxygen and thus allow strict anaerobes to survive. Obtaining strict anaerobes in pure culture, and elucidating the novel biochemical reactions they catalyze, required the development of specialized techniques (Barker 1940; Hungate 1985).

Several decades ago, microbiologists used such techniques as roll-tubes to cultivate strictly anaerobic prokaryotes such as methanogenic bacteria. More recently, people routinely began using crimp-sealed, septum-plugged bottles for liquid cultures and putting Petri plates into anaerobic chambers containing an inert gas such as helium or argon. The latter can routinely be maintained at oxygen levels of around one part per million when coupled with oxygen scrubbers for the gas mixtures and catalyst cartridges inside the anaerobic chamber.

Anaerobic biodegradation is also difficult to study in another context. Anaerobic enrichment cultures may initially show very long lag phases, perhaps 6 months or 1 year, before significant biodegradation occurs. Upon repeated transfer, the lag phase often shortens continually. Still, many years may be required to achieve significantly rapid rates of biodegradation, and those may never approach the rates of comparable aerobic

biodegradation. In most cases, a definitive explanation for the lag phase phenomenon is lacking. It is these kinds of impediments which have skewed the focus of laboratory studies in biodegradation toward the fast-growing aerobic prokaryotes such as *Pseudomonas* species, which can be grown overnight with simple equipment and typically yield high cell densities.

Despite this, anaerobes offer rewards to those who persevere by providing for the discovery of the most novel biochemical reactions on Earth. Some of these reactions have recently been elucidated. For example, bacteria are now known to catabolize toluene anaerobically. They initiate attack on the benzylic carbon via a radical mechanism that generates a new carbon-carbon bond to form benzylsuccinate as the first metabolite (Leuthner et al. 1998). Others, such as the anaerobic formation of methane from long-chain alkanes (Zengler et al. 1999), remain obscure biochemically.

Analytical Chemistry

Chemical methods for analyzing organic compounds have improved enormously since the late 1800s when use of enrichment culture methods began. Thus, obtaining pure cultures has gone hand in hand with new methods for analyzing the intermediates and products of their metabolism. Thus, one might anticipate a biodegradative metabolic pathway based on chemical logic, obtain authentic chemical standards, and screen for the presence of such compounds in growth cultures of the microbial isolate. But how does one screen for the compound(s)?

Chromatography, coupled to the use of authentically synthesized standard compounds, has been a powerful method for studying biodegradation over the last century, and it remains so today. There have been big advances in the science of chromatographic separations. A century ago, thin-layer chromatography (TLC) was state of the art. Later, gas chromatography (GC) provided better resolution, and most recently, high-pressure liquid chromatography (HPLC) gives excellent resolution and the ability to capture and further analyze compounds.

Identification of compounds in complex mixtures is being aided by new developments in mass spectrometry (MS), which may be coupled with isotopic labeling for additional power. Similarly, with high-field nuclear magnetic resonance (NMR) spectroscopy and the use of specifically labeled ^{13}C -compounds becoming increasingly available, it is now feasible to monitor metabolism in situ (Sauer et al. 1999). This, in turn, may lead to a revolution in environmental microbiology, in which systems more resembling natural systems can be analyzed with respect to biodegradation.

Whole Genome Sequencing and Analysis

Biodegradative genes have been identified, usually by transferring the DNA containing a specific gene(s) from a pure culture environmental isolate into *Escherichia coli* for sequencing and functional expression. With a substantial set of genes available, it is becoming routine to screen soils for the presence of

homologous genes that might be involved in identical or similar biodegradative reactions. This gives insights into the environmental prevalence of certain biodegradative genes.

In the last several years, DNA sequencing techniques have advanced to the point that we can readily sequence entire prokaryote genomes (Nelson et al. 2000). With appropriate annotation techniques, this can provide insight into the metabolic pathways encoded by the genes. Theoretically, an organism's entire network of metabolism can be deduced. In practice, deducing metabolism is an imperfect task. Consider that the complete genomic DNA sequence of *Escherichia coli*, the most intensely studied biochemical entity on Earth, yielded 38 % of the coding regions having unknown function (Blattner et al. 1997). If there are gaps in the metabolic map of *E. coli*, there will be many more as we proceed to sequence the genomic DNA of soil isolates important in biodegradation. Despite this caveat, it is exciting to contemplate the explosive increase in obtaining complete genome sequences for an expanding array of prokaryotes. This will spur a resurgence of interest in comparative biochemistry, with an attendant interest in new "exotic" genes. I predict that a significant number of the newly discovered gene functions in soil Eubacteria will be involved in the biodegradation of organic compounds. This will enhance interest in biodegradation and microbial biocatalysis, in general, as the era of functional genomics comes into full swing.

The Prokaryotes of Biodegradation

Our current perspective on the microorganisms of biodegradation derives largely from enrichment culture methods, isolating pure cultures and studying the individual reactions of biodegradation. Table 15.1 shows the list of prokaryotes and compounds they degrade; the biodegradative pathways each of them initiate are depicted in the UM-BBD. An analogous microorganism index can be found at umbbd.ahc.umn.edu (UM-BBD).

The UM-BBD Microorganism Index has links for the entries containing both genus and species names to the corresponding entries on websites maintained by the American Type Culture Collection (ATCC) or the Deutsche Sammlung von Mikroorganismen und Zellkulturen (DSMZ). Another excellent web resource that deals with microorganisms which are important in biodegradation is the Biodegradative Strain Database (BSD) bsd.cme.msu.edu maintained at Michigan State University by John Urbance, Jim Cole, and Jim Tiedje.

The BSD microorganism listings, in turn, link to (<http://www.cme.msu.edu> (Ribosomal RNA Database) and to biodegradative pathways maintained on the UM-BBD.

Several trends are apparent from perusing the data in Table 15.1. First, biodegradative capabilities are widespread phylogenetically within the *Proteobacteria*, high G + C Gram-positive bacteria, and *Flavobacterium* in the *Cytophagales*-green sulfur bacteria. As discussed in the section above, this reflects the facile transfer of genes, especially those that might be contained on plasmids or flanked by transposable elements.

Table 15.1

Prokaryote genera identified in biodegradation and the compounds they metabolize^a

Prokaryote genus	Compound undergoing biodegradation
<i>Acetobacterium</i>	Triethanolamine
	Carbon tetrachloride
<i>Achromobacter</i>	2,4-Dichlorobenzoate
<i>Acinetobacter</i>	Cyclohexanol
	2-Chloro- <i>N</i> -isopropylacetanilide
<i>Actinomycetes</i>	2,4,6-Trinitrotoluene (TNT)
<i>Aeromonas</i>	Phenanthrene
<i>Agrobacterium</i>	Glyphosate
	1,2,3-Tribromopropane
	Atrazine
<i>Alcaligenes</i>	2,4-Dichlorobenzoate
	2,4-Dichlorophenoxyacetic acid (2,4-D)
	2,4-Dichlorobenzoate
	2-Aminobenzenesulfonate
	Toluene-4-sulfonate
	Atrazine
<i>Ancylobacter</i>	1,2-Dichloroethane
	2,4-Dichlorophenoxyacetic acid
	4-Nitrophenol
	1,3-Dichloro-2-propanol
	Tyrosine
	2,4-Dichlorobenzoate
	Glyphosate
	Parathion
<i>Arthrobacter</i>	2,4-Dichlorophenoxyacetic acid (2,4-D)
	4-Nitrophenol
	Octamethylcyclotetrasiloxane
	Iprodione
	1,3-Dichloro-2-propanol
	Fluorene
	Tyrosine
	2,4-Dichlorobenzoate
	Glyphosate
	Methyl <i>tert</i> -butyl ether
	Nicotine
	2-Aminobenzoate
Phenanthrene	
Parathion	
<i>Azoarcus</i>	Benzoate
	Toluene
<i>Azotobacter</i>	2,4-Dichlorophenoxyacetic acid (2,4-D)
	Thiocyanate
<i>Bacillus</i>	2,4,6-Trinitrotoluene
	2-Phenylacetaldoxime
<i>Beijerinckia</i>	Xylene

Table 15.1 (continued)

Prokaryote genus	Compound undergoing biodegradation
<i>Brevibacterium</i>	Dibenzofuran
	Nitrobenzene
<i>Brevundimonas</i>	Parathion
<i>Burkholderia</i>	2,4-Dichlorophenoxyacetic acid (2,4-D)
	1,2,4-Trichlorobenzene
	Phthalates
	Benzoate
	Pentachlorophenol
	2,4,5-Trichlorophenoxyacetic acid (2,4,5-T)
	3-Chloroacrylic acid
	Toluene
	Trichloroethylene
<i>Clavibacter</i>	2,4-Dichlorobenzoate
<i>Clostridium</i>	Atrazine
	2,4,6-Trinitrotoluene (TNT)
<i>Clostridium</i>	Phenol
<i>Chelatobacter</i>	Nitrioltriacetate
<i>Comamonas</i>	Nitrobenzene
	3-Methylquinoline
	Phthalates
	Toluene-4-sulfonate
<i>Corynebacterium</i>	1,3-Dichloro-2-propanol
	2,4-Dichlorobenzoate
<i>Dehalobacter</i>	Tetrachloroethene
<i>Dehalococcoides</i>	Tetrachloroethene
<i>Dehalospirillum</i>	Tetrachloroethene
<i>Desulfotobacterium</i>	Tetrachloroethene
<i>Desulfobacterium</i>	Carbon tetrachloride
<i>Desulfovibrio</i>	2,4,6-Trinitrotoluene (TNT)
<i>Enterobacter</i>	Glyphosate
	1,1,1-Trichloro-2,2-bis-(4-chlorophenyl) ethane (DDT)
	Pentaerythritol tetranitrate
<i>Escherichia</i>	3-Phenylpropionate
	Arsonoacetate
	Phenylmercuric chloride
<i>Eubacterium</i>	Gallate
<i>Exophiala</i>	Styrene
<i>Flavobacterium</i>	Bromoxynil
	2,4-Dichlorophenoxyacetic acid (2,4-D)
	Glyphosate
	Parathion
	Pentachlorophenol
<i>Hydrogenophaga</i>	4-Carboxy-4'-sulfoazobenzene
<i>Hyphomicrobium</i>	Dichloromethane
	Dimethyl sulfoxide

Table 15.1 (continued)

Prokaryote genus	Compound undergoing biodegradation
<i>Klebsiella</i>	Benzonitrile
	Bromoxynil
	Acetylene
<i>Lactobacillus</i>	1,1,1-Trichloro-2,2-bis-(4'-chlorophenyl) ethane (DDT)
	2,4,6-Trinitrotoluene (TNT)
<i>Methanobacterium</i>	Carbon tetrachloride
<i>Methanosarcina</i>	Tetrachloroethene
	Carbon tetrachloride
<i>Methylobacterium</i>	Dichloromethane
	Methyl <i>tert</i> -butyl ether
<i>Methylococcus</i>	Thiocyanate
<i>Methylophilus</i>	Dichloromethane
<i>Methylosinus</i>	Trichloroethylene
<i>Methylosulfonomonas</i>	Methanesulfonic acid
<i>Moorella</i>	Carbon tetrachloride
<i>Moraxella</i>	4-Nitrophenol
	2-Chloro- <i>N</i> -isopropylacetanilide
	Naphthalenesulfonates
<i>Mycobacterium</i>	Methyl <i>tert</i> -butyl ether
<i>Myrothecium</i>	Cyanamide
<i>Neurospora</i>	2-Nitropropane
<i>Nitrosomonas</i>	Methyl fluoride
	Dimethyl ether
<i>Nocardia</i>	Methyl <i>tert</i> -butyl ether
	Parathion
	Methyl ethyl ketone
<i>Pelobacter</i>	Acetylene
<i>Proteus</i>	1,1,1-Trichloro-2,2-bis-(4-chlorophenyl) ethane (DDT)
<i>Pseudomonas</i>	Acrylonitrile
	2-Aminobenzoate
	1,3-Dichloropropene
	Dichloromethane
	Dimethyl sulfoxide
	Carbazole
	Benzoate
	<i>p</i> -Xylene
	<i>p</i> -Cymene
	Carbon tetrachloride
	Fluorene
	Adamantanone
	3-Chloroacrylic acid
	2-Chloro- <i>N</i> -isopropylacetanilide
	1,4-Dichlorobenzene
	Parathion
Nitroglycerin	

Table 15.1 (continued)

Prokaryote genus	Compound undergoing biodegradation
	Toluene
	Octane
	Nitrobenzene
	4-Chlorobiphenyl
	Dibenzothiophene
	Orcinol
	Xylene
	Ethylbenzene
	Mandelate
	Styrene
	Trichloroethylene
	Toluene-4-sulfonate
	<i>m</i> -Xylene
	Atrazine
	Naphthalenesulfonates
	2,4-Dichlorobenzoate
	Chlorobenzene
	2-Aminobenzoic acid
	4-Chlorobiphenyl
	Ethylbenzene
	Naphthalene
	Chlorobenzene
	1-Aminocyclopropane-1-carboxylate
	Biphenyl
	Caprolactam
	Phenanthrene
	1,1,1-Trichloro-2,2-bis-(4-chlorophenyl) ethane (DDT)
	2,4,6-Trinitrotoluene
	<i>m</i> -Cresol
	Thiocyanate
	Phenylmercuric chloride
	<i>n</i> -Octane
	Dodecyl sulfate
	Bromoxynil
	Dibenzothiophene
	2,4-Dichlorobenzoate
	Mandelate
	Methyl <i>tert</i> -butyl ether
	(+)-Camphor
	2,4-Dichlorophenoxyacetic acid
<i>Ralstonia</i>	Atrazine
	1,1,1-Trichloro-2,2-bis(4'-chlorophenyl) ethane (DDT)
	Dimethyl sulfoxide
<i>Rhodobacter</i>	Acetylene

Table 15.1 (continued)

Prokaryote genus	Compound undergoing biodegradation
<i>Rhodococcus</i>	Atrazine
	Acrylonitrile
	Methyl <i>tert</i> -butyl ether
	Cyclohexanol
	Bromoxynil
	Styrene
	Tetrahydrofuran
	Benzonitrile
	Dibenzothiophene
	Benzoate
<i>Rhodopseudomonas</i>	2,4,6-Trinitrotoluene (TNT)
<i>Salmonella</i>	<i>n</i> -Octane
	Dibenzofuran
<i>Sphingomonas</i>	Carbazole
	γ -1,2,3,4,5,6-Hexachlorocyclohexane
	Dibenzo- <i>p</i> -dioxin
	Xylenes
	Tetrachloroethene
<i>Sporomusa</i>	Dibenzofuran
<i>Staphylococcus</i>	2,4,6-Trinitrotoluene
	Arsonoacetate
	Fluorene
	Atrazine
<i>Streptomyces</i>	Phenanthrene
	1,1,1-Trichloro-2,2-bis-(4-chlorophenyl) ethane (DDT)
<i>Synechococcus</i>	Phenanthrene
	Dibenzofuran
<i>Terrabacter</i>	Toluene
<i>Thauera</i>	Benzoate
	Phenol
	Thiocyanate
<i>Thiobacillus</i>	1,2-Dichloroethane
<i>Xanthobacter</i>	1,4-Dichlorobenzene
	2-Chloro- <i>N</i> -isopropylacetanilide
	2-Nitropropane
	Propylene

^aA similar list with links to the metabolic pathways can be obtained on the UM-BBD at <http://umbbd.ahc.umn.edu/search/micro.html>

Second, there are several genera of bacteria, which have emerged repeatedly as having diverse catabolism, particularly with starting compounds we think of as metabolically unusual, such as synthetic industrially relevant organic compounds. The latter include herbicides, insecticides, industrial solvents, and

■ Table 15.2

Microbes recently identified as organic pollutant biodegraders, but falling outside of the prokaryotic groupings typically isolated for studies on biodegradation

Prokaryote ^a	Taxonomic group	Substrate	References
<i>Haloanaerobium praevalens</i>	<i>Haloanaerobiales</i>	Nitrobenzene	Oren et al. (1991)
		<i>o</i> -Nitrophenol	
		<i>m</i> -Nitrophenol	
		<i>p</i> -Nitrophenol	
		Nitroanilines	
		2,4-Dinitrophenol	
		2,4-Dinitroaniline	
<i>Sporohalobacter marismortui</i>	<i>Haloanaerobiales</i>	Nitrobenzene	Oren et al. (1991)
		<i>o</i> -Nitrophenol	
		<i>m</i> -Nitrophenol	
		<i>p</i> -Nitrophenol	
		Nitroanilines	
		2,4-Dinitrophenol	
		2,4-Dinitroaniline	
<i>Borrelia burgdorferi</i>	Spirochaetales	Benzamides	Dettoni et al. (1995)
<i>Borrelia hermsii</i>			
<i>Bacteroides fragilis</i>	Cytophagales	Alkylhydroperoxides	Rocha and Smith (1999)
<i>Desulfotobacterium dehalogenans</i>	<i>Heliobacterium</i>	Polychlorinated biphenyls	Wiegel et al. (1999)
<i>Desulfotobacterium hafniense</i>	<i>Heliobacterium</i>	3-Chloro-4-hydroxy-phenylacetate	Christiansen et al. (1998)
<i>Desulfotobacterium dehalogenans</i>	<i>Heliobacterium</i>	Chlorophenols	van de Pas et al. (1999)

^aThese bacteria do not belong to the following groups: Proteobacteria and high and low G + C Gram-positive bacteria

synthetic intermediates. As illustrated in ► Table 15.1, the following genera are particularly well represented: *Arthrobacter*, *Burkholderia*, *Pseudomonas*, and *Rhodococcus*. The caveat to these observations is that we have largely depicted biodegradation pathways catalyzed by prokaryotes, which have been obtained in pure culture via enrichment culture. Thus, we have selectively depicted microorganisms that grow well under conditions typically used for enrichment culture and the maintenance of pure culture isolates in the laboratory. These microbial strains may only reflect some fraction, perhaps a small fraction, of the prokaryotes that actively carry out biodegradation in the soils and waters of the Earth. The complete genome sequencing of both pure culture bacteria and genomic DNA from soil, the so-called soil metagenome (Rondon et al. 2000), may help address this question by helping unveil what percentage of the total genome of a given organism functions in non-intermediary catabolic metabolism. In another example, culture-independent molecular methods were used to analyze microbial communities in an aquifer contaminated with hydrocarbons and chlorinated solvents in which active biodegradation was occurring (Dojka et al. 1998). In that study, 16S rRNA sequences were determined for 21 bacterial members of the consortium, belonging to four recently described divisions of bacteria for which there are no cultivated representatives. Moreover, two particularly abundant 16S rRNA sequence types were implicated in the overall hydrocarbon metabolism. They were members of the genera *Syntrophus*

and *Methanosaeta*, both of which were proposed to participate in aceticlastic methanogenesis at the end of the catabolic food chain.

In parallel with molecular nonculture methods, the well-established methods of enrichment culture are more frequently being applied under anaerobic and other nonstandard conditions in an effort to obtain novel microbial types. This approach also suggests that biodegradative capabilities are more widespread in the microbial world than has been appreciated by some. For example, halophiles have been identified which metabolize nitroarenes, and members of the *Heliobacterium* group are known that catabolize polychlorinated biphenyls (PCBs) and chlorophenols (► Table 15.2). These and other recent observations are expanding the taxonomic range of bacteria that catabolize environmental pollutants. Further experiments are likely to expand this further.

Themes in Biodegradation Pathways

Occurrence of Similar Pathways in Divergent Prokaryotes

Gene transfer among prokaryotes is quite facile, and our appreciation of this seems to be increasing all the time. The genes most prone to transfer are those conferring survival advantage only

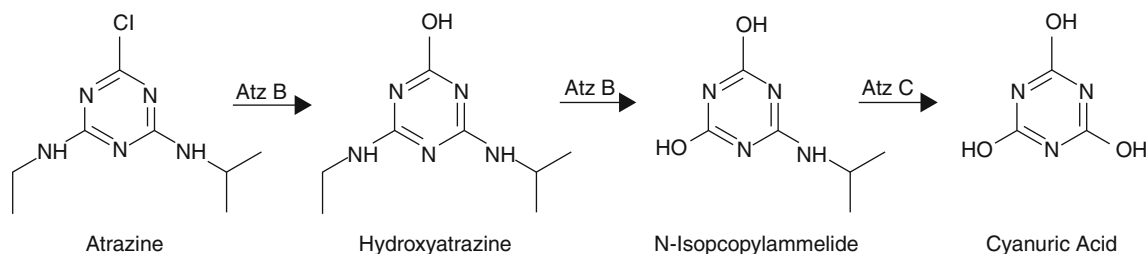

Fig. 15.1

Catabolic pathway for the catabolism of atrazine in *Pseudomonas* sp. ADP

under specialized conditions, the so-called dispensable genes. Principal among those genes are ones conferring antibiotic resistance, heavy metal resistance, or new catabolic activities. These genes are commonly found on plasmids. Many catabolic plasmids have been shown to have a broad host-range and transfer by conjugation in the absence of helper plasmids. Thus, the genes, and the metabolic functions they encode, can show up in diverse prokaryotes. An example will best serve to illustrate this point.

In 1995, a *Pseudomonas* species, denoted strain ADP, was isolated from an enrichment culture in which the herbicide atrazine was supplied as the sole source of nitrogen (Mandelbaum et al. 1995). Subsequent studies over the ensuing three years elucidated the atrazine-catabolic pathway and yielded the DNA sequences of the genes encoding the first three metabolic steps (► Fig. 15.1). During the same period, other laboratories isolated atrazine-catabolizing prokaryotes using different enrichment and isolation conditions (Bouquard et al. 1997; de Souza et al. 1998a, b; Radosevich et al. 1995; Struthers et al. 1998). The bacteria were subjected to taxonomic determination and found to be members of the following genera, respectively: *Rhizobium*, *Agrobacterium*, *Ralstonia*, and *Clavibacteria*. In our laboratory, DNA from each of the distinct atrazine-catabolizing bacteria was prepared (de Souza et al. 1998b). They were each found to contain genes with more than 99 % sequence identity to the atrazine genes from the original *Pseudomonas* sp. ADP isolate. This occurred despite the fact that the organisms were isolated independently in different regions of Earth, by different groups, and under different conditions. These observations are consistent with a facile transfer of the atrazine-catabolic genes among soil prokaryotes.

In another example, illustrated by perusing the UM-BBD, the same organic compound is metabolized by different genera of bacteria via different intermediates. Examples of starting compounds are:

Atrazine
Fluorene
Glyphosate
Nitrobenzene
4-Nitrophenol
Parathion

Phenanthrene
Styrene
Toluene
2, 4,6-Trinitrotoluene

Common Themes in Catabolic Pathways

Although some catabolic pathways are widespread, there are some correlations between certain types of metabolism and the prokaryotic group catalyzing those reactions. This can be attributed to the compatibility between the catabolic reactions and the core metabolic pathways that the catabolic intermediates feed into. This is particularly well illustrated for chemical compounds which are composed of a single carbon atom or which are readily metabolized to C-1 fragments.

► Figure 15.2 shows the C-1 meta-pathway, which is also depicted in the (http://umbbd.ahc.umn.edu/c1/c1_map.html [UM-BBD]). At the core of the map are the oxidative and reductive parts of the C-1 metabolic cycle, which is important on a global scale as discussed previously. Anaerobic Archaea (known as methanogens) catalyze the reductive reactions that transform carbon dioxide to methane. These organisms are important members of certain anaerobic consortia involved in the biodegradation of complex organic matter such as cellulosic wastes. Methanogens occupy the end of the anaerobic food chain in the overall biodegradative process.

A class of prokaryotes called “methanotrophs” (► Fig. 15.2) carry out the oxidative reactions leading from methane, the most reduced C-1 compound, to carbon dioxide, the most oxidized. Some C-1 oxidizing organisms (known as “methylotrophs”) cannot oxidize methane to methanol but can carry out the next three oxidative reactions. Methane is a common natural product; it is the main constituent of natural gas. Moreover, data suggests that a majority of the methane generated in lake sediments is oxidized in higher, aerobic levels of the lake by methanotrophs, and thus methane never enters the atmosphere.

Methanotrophic and methylotrophic metabolism may be expanded to include a set of oxidative, hydrolytic or thiolytic reactions whereby simple organic structures can be transformed to the methanotrophic intermediates methanol, formaldehyde,

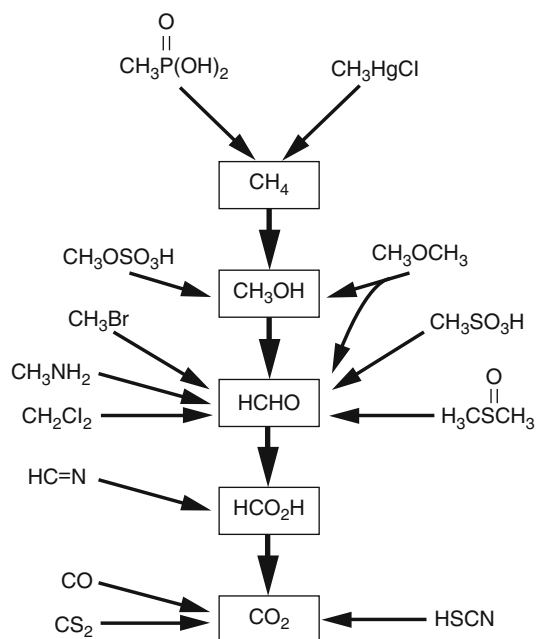

■ Fig. 15.2

Catabolism of organic compounds containing one carbon atom that funnel into the central intermediates of methanotrophy: methane, methanol, formaldehyde, and formate

or formate (► Fig. 15.2). Some of these compounds are natural products, for example, dimethyl sulfide, methylamine, and methyl chloride. Others are predominantly the products of organic synthesis: dichloromethane, dimethyl ether, and methyl fluoride. Regardless of their origin, these compounds are readily transformable to methanotrophic metabolic intermediates, and thus, some methanotrophs will grow on them as their sole source of carbon and energy. This catabolic metabolism is not universal, however. Only some small subset of the total set of methanotrophs and methylotrophs will grow on a given compound shown at the periphery of ► Fig. 15.2. But methanotrophs and methylotrophs are common in nature, and thus, dichloromethane, dimethyl ether, and methyl fluoride are generally thought of as being fairly biodegradable.

Another common theme is seen in the transformation of the commercially important BTEX compounds (i.e., benzene, toluene, ethylbenzene, and xylenes). They are clustered because of their co-occurrence in environmental contamination stemming from spillage of petroleum materials. Because BTEX compounds are structurally analogous to each other, there are commonalities in their metabolism by prokaryotes. Anaerobic metabolism of BTEX compounds has been studied only more recently, and the biochemical basis of the biodegradation reactions is now being revealed. The aerobic metabolism of BTEX compounds is much better studied. For example, see ► Fig. 15.3 and (http://umbbd.ahc.umn.edu/BTEX/BTEX_map.html#aerobic). Almost invariably, oxygenase enzymes initiate the metabolism to produce ring cis-dihydrodiols, phenols, benzyl alcohols, and ultimately catechols,

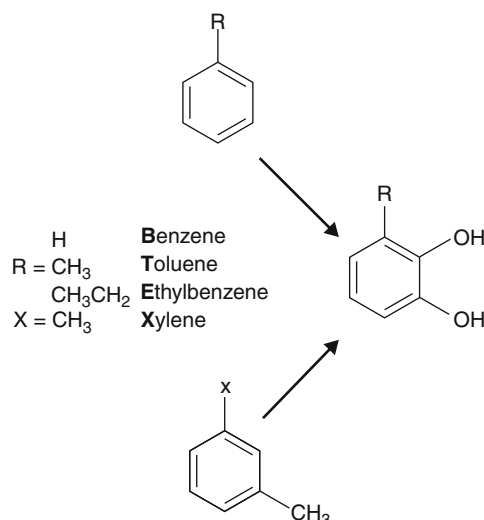

■ Fig. 15.3

Convergence of aerobic pathways for BTEX compounds leads to a catechol intermediate

which undergo ring cleavage. These alcohol products are all more activated than their aromatic hydrocarbon starting compounds. There are multiple pathways possible, but all of them produce catechol intermediates. To follow all known aerobic prokaryotic metabolic pathways for each of the BTEX compounds, follow the links:

Benzene
 Toluene
 Ethylbenzene
o-Xylene
m-Xylene
p-Xylene

The metabolic strategy for BTEX compounds used by aerobic prokaryotes differs from that used by aerobic eukaryotic organisms such as fungi (Cerniglia et al. 1978) and mammals (Jerina et al. 1968). The latter group also uses oxygenase enzymes to attack resonance-stabilized aromatic hydrocarbons. However, the initial products of the oxygenase-catalyzed reactions are often arene oxides (► Fig. 15.4). Aromatic alcohols are detected but are shown to largely arise from spontaneous isomerization of the arene oxides and are not direct enzyme products. This contrasts with the prokaryote aromatic ring monooxygenation reactions in which the phenol product is detected directly. For example, with toluene catabolism by *Burkholderia cepacia* G4, the initial reaction product is 2-hydroxytoluene, or *o*-cresol, exclusively. There was no evidence for the intermediate formation of toluene 2,3-epoxide, which would have isomerized to a mixture of *o*-cresol and *m*-cresol. The data do not rule out that an epoxide is an enzyme-bound intermediate that undergoes a controlled isomerization on the enzyme surface. This would be advantageous to the organism, as epoxides are reactive electrophiles and can

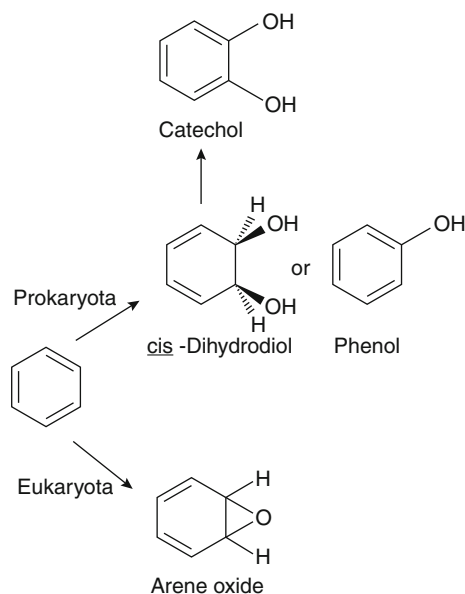

Fig. 15.4

Divergence in the catabolism of aromatic compounds by Prokaryota and Eukaryota

alkylate proteins and other molecules in the cell. So a high-flux metabolic pathway that produces such a reactive species might well be selected against during evolution. In contrast, the mammalian metabolism of BTEX compounds is largely low-flux metabolism to scavenge stray hydrocarbons that may enter the body. Other enzymes further metabolize the epoxide products to make intermediates that are excreted from the animal. A nonspecific detoxification metabolism such as this may work best when it proceeds through an initial arene oxide intermediate.

Acknowledgments

I thank the many talented colleagues with whom I have collaborated on metabolic pathways of biodegradation. Special thanks go to Professor Lynda Ellis for her meticulous work on the University of Minnesota Biocatalysis/Biodegradation Database, making it a resource that has been worth accessing millions of times by researchers around the world.

References

- Barker HA (1940) Studies on the methane fermentation. IV: the isolation and culture of *Methanobacterium omelianskii*. *Antonie Van Leeuwenhoek* 6:201–220
- Beijerinck MW (1901) Enrichment culture studies with urea bacteria. *Cen Bakteriöl* 7(II):33–61
- Blattner FR, Plunkett G III, Bloch CA, Perna NT, Burland V, Riley M, Collado-Vides J, Glasner JD, Rode CK, Mayhew GF, Gregor J, Davis NW, Kirkpatrick HA, Goeden MA, Rose DJ, Mau B, Shao Y (1997) The complete genome sequence of *Escherichia coli* K-12. *Science* 277:1453–1474

- Bouquard C, Ouazzani J, Prome JC, Michel-Briand Y, Plesiat P (1997) Dechlorination of atrazine by a *Rhizobium* sp. isolate. *Appl Environ Microbiol* 63:862–866
- Bulbulyan MA, Figgs LW, Zahm SH, Savitskaya T, Goldfarb A, Astashevsky S, Zaridze D (1995) Cancer incidence and mortality among beta-naphthylamine and benzidine dye workers in Moscow. *Int J Epidemiol* 24:266–275
- Bull AT, Slater JH (1982) In: Bull AT, Slater JH (eds) *Microbial interactions and communities*. Academic, New York
- Cerniglia CE, Hebert RL, Szanislo PJ, Gibson DT (1978) Fungal transformation of naphthalene. *Arch Microbiol* 117:135–143
- Christiansen N, Ahring BK, Wohlfarth G, Diekert G (1998) Purification and characterization of the 3-chloro-4-hydroxy-phenylacetate reductive dehalogenase of *Desulfotobacterium hafriense*. *FEBS Lett* 436:159–162
- Clarke PH (1985) The scientific study of bacteria, 1780–1980. In: Leadbetter ER, Poindexter JS (eds) *Bacteria in nature*, vol I. Plenum, New York, pp 1–37
- de Souza ML, Newcombe D, Alvey S, Crowley DE, Hay A, Sadowsky MJ, Wackett LP (1998a) Molecular basis of a bacterial consortium: interspecies catabolism of atrazine. *Appl Environ Microbiol* 64:178–184
- de Souza ML, Seffernick J, Martinez B, Sadowsky SJ, Wackett LP (1998b) The atrazine catabolism genes *atzABC* are widespread and highly conserved. *J Bacteriol* 180:1951–1954
- Dettoni G, Grillo R, Cattani P, Calderaro A, Chezzi C, Milner J, Truelove K, Sellwood R (1995) Comparative study of the enzyme activities of *Borrelia burgdorferi* and other non-intestinal and intestinal spirochaetes. *New Microbiol* 18:13–26
- Dojka MA, Hugenholtz P, Haack SK, Pace NR (1998) Microbial diversity in a hydrocarbon- and chlorinated-solvent-contaminated aquifer undergoing intrinsic bioremediation. *Appl Environ Microbiol* 64:3869–3877
- Ellis LBM, Hershberger CD, Wackett LP (2000) The University of Minnesota biocatalysis/biodegradation database: microorganisms, genomics and prediction. *Nucleic Acids Res* 28:377–379
- Goto S, Nishioka T, Kanehisa M (2000) LIGAND: chemical database of enzyme reactions. *Nucleic Acids Res* 28:380–382
- Harkness MR, McDermott JB, Abramowicz DA, Salvo JJ, Flanagan WP, Stephens ML, Mondello FJ, May RJ, Lobos JH, Carroll KM, Brennan MJ, Bracco AA, Fish KM, Warner GL, Wilson PR, Dietrich DK, Lin DT, Morgan CB, Gately WL (1993) In situ stimulation of aerobic PCB biodegradation in Hudson River sediments. *Science* 259:503–507
- Hungate RE (1985) Anaerobic fermentations. In: Poindexter JS, Leadbetter ER (eds) *Bacteria in nature*, vol I. Plenum, New York, pp 39–95
- Jerina DM, Daly JW, Witkop B, Zaltzman-Nirenberg P, Udenfriend S (1968) The role of arene oxide-oxepin systems in the metabolism of aromatic substrates. 3: formation of 1,2-naphthalene oxide from naphthalene by liver microsomes. *J Am Chem Soc* 90:6525–6527
- Langard S, Rosenberg J, Andersen A, Heldaas SS (2000) Incidence of cancer among workers exposed to vinyl chloride in polyvinyl chloride manufacture. *Occup Environ Med* 57:65–68
- Leuthner B, Leutwein C, Schulz H, Horth P, Haehnel W, Schiltz E, Schagger H, Heider J (1998) Biochemical and genetic characterization of benzylsuccinate synthase from *Thauera aromatica*: a new glycol radical enzyme catalysing the first step in anaerobic toluene metabolism. *Mol Microbiol* 28:615–628
- Lipscomb JD (1994) Biochemistry of the soluble methane monooxygenase. *Annu Rev Microbiol* 48:371–399
- Maltoni C, Cotti G (1988) Carcinogenicity of vinyl chloride in Sprague-Dawley rats after prenatal and postnatal exposure. *Ann N Y Acad Sci* 534:145–159
- Mandelbaum RT, Allan DA, Wackett LP (1995) Isolation and characterization of a *Pseudomonas* sp. that mineralizes the *s*-triazine herbicide atrazine. *Appl Environ Microbiol* 61:1451–1457
- Nelson KE, Paulsen IT, Heidelberg JF, Fraser CM (2000) Status of genome projects for nonpathogenic bacteria and archaea. *Nat Biotechnol* 18:1049–1054
- Oren A, Gurevich P, Henis Y (1991) Reduction of nitrosubstituted aromatic compounds by the halophilic anaerobic eubacteria *Haloanaerobium prevaleans* and *Sporohalobacter marismortui*. *Appl Environ Microbiol* 57:3367–3370

- Radosevich M, Traina SJ, Hao Y, Tuovinen OH (1995) Degradation and mineralization of atrazine by a soil bacterial isolate. *Appl Environ Microbiol* 61:297–302
- Roberts DJ, Kaake RH, Funk SB, Crawford DL, Crawford RL (1993) Anaerobic remediation of dinoseb from contaminated soil: an on-site demonstration. *Appl Biochem Biotechnol* 39–40:781–789
- Rocha ER, Smith CJ (1999) Role of the alkyl hydroperoxide reductase (ahpCF) gene in oxidative stress defense of the obligate anaerobe *Bacteroides fragilis*. *J Bacteriol* 181:5701–5710
- Rondon MR, August PR, Bettermann AD, Brady SF, Grossman TH, Liles MR, Loiacono KA, Lynch BA, MacNeil IA, Minor C, Tiong CL, Gilman M, Osburne MS, Clardy J, Handelsman J, Goodman RM (2000) Cloning the soil metagenome: a strategy for accessing the genetic and functional diversity of uncultured microorganisms. *Appl Environ Microbiol* 66:2541–2547
- Sauer U, Lasko DR, Fiaux J, Hochuli M, Glaser R, Szyperski T, Wuthrich K, Bailey JE (1999) Metabolic flux ratio analysis of genetic and environmental modulations of *Escherichia coli* central carbon metabolism. *J Bacteriol* 181:6679–6688
- Strong LC, McTavish H, Sadowsky MJ, Wackett LP (2000) Field-scale remediation of atrazine-contaminated soil using recombinant *Escherichia coli* expressing atrazine chlorohydrolase. *Environ Microbiol* 2:91–98
- Struthers JK, Jayachandran K, Moorman TB (1998) Biodegradation of atrazine by *Agrobacterium radiobacter* J14a and use of this strain in bioremediation of contaminated soil. *Appl Environ Microbiol* 64:3368–3375
- Van de Pas BA, Smidt H, Hagen WR, van der Oost J, Schraa G, Stams AJ, de Vos W (1999) Purification and molecular characterization of ortho-chlorophenol reductive dehalogenase, a key enzyme of halo-respiration in *Desulfitobacterium dehalogenans*. *J Biol Chem* 274:20287–20292
- Vogel TM, McCarty PL (1985) Biotransformation of tetrachloroethylene to trichloroethylene, dichloroethylene, vinyl chloride, and carbon dioxide under methanogenic conditions. *Appl Environ Microbiol* 49:1080–1083
- Wagner-Dobler I, von Canstein H, Li Y, Timmis KN, Deckwer W-D (2000) Removal of mercury from chemical wastewater by microorganisms in technical scale. *Environ Sci Technol* 34:4628–4634
- Wiegel J, Zhang X, Wu Q (1999) Anaerobic dehalogenation of hydroxylated polychlorinated biphenyls by *Desulfitobacterium dehalogenans*. *Appl Environ Microbiol* 65:2217–2221
- Winogradsky S (1890) Sur les organismes de la nitrification. *C R Acad Sci* 110:1013–1016
- Zengler K, Richnow HH, Rossello-Mora R, Michaelis W, Widdel F (1999) Methane formation from long-chain alkanes by anaerobic microorganisms. *Nature* 401:266–269

